

---

**HP 70810B  
Lightwave Section  
(includes Option 850)**

**User's Guide**



Printed in USA

HP part number: 70810-90067  
Printed in USA June 1994  
First Edition

This manual and any examples contained herein are provided “as is” and are subject to change without notice. Hewlett-Packard makes no warranty of any kind with regard to this material, including but not limited to, the implied warranties of merchantability and fitness for a particular purpose. Hewlett-Packard shall not be liable for errors contained herein or for incidental or consequential damages in connection with the furnishing, performance, or use of this material.

**Note**

---

This instrument has been designed and tested in accordance with IEC Publication 348, *Safety Requirements for Electronic Measuring Apparatus*, and has been supplied in a safe condition. The instruction documentation contains information and warnings which must be followed by the user to ensure safe operation and to maintain the instrument in a safe condition.

---

© Copyright Hewlett-Packard Company 1991, 1994  
All Rights Reserved. Reproduction, adaptation, or translation without prior written permission is prohibited, except as allowed under the copyright laws.

---

## Safety Notes

### Warning

- **No operator-serviceable parts inside. Refer servicing to qualified personnel. To prevent electrical shock, do not remove covers.**
- **For continued protection against fire hazard, replace line fuse only with same type and ratings (type 6.3A/250V). The use of other fuses or materials is prohibited.**
- **This is a Safety Class 1 Product (provided with a protective earthing ground incorporated in the power cord.) The mains plug shall only be inserted in a socket outlet provided with a protective earth contact. Any interruption of the protective conductor inside or outside of the instrument is likely to make the instrument dangerous. Intentional interruption is prohibited.**
- **If this instrument is not used as specified, the protection provided by the equipment could be impaired. This instrument must be used in a normal condition (in which all means for protection are intact) only.**

---

### Caution

- Always use the three-prong AC power cord supplied with this instrument. Failure to ensure adequate earth grounding by not using this cord may cause instrument damage.
  - This instrument is designed for use in Installation Category II and Pollution Degree 2 per IEC 1010 and 664 respectively.
  - **Ventilation Requirements:** When installing the instrument in a cabinet, the convection into and out of the instrument must not be restricted. The ambient temperature (outside the cabinet) must be less than the maximum operating temperature of the instrument by 4 °C for every 100 watts dissipated in the cabinet. If the total power dissipated in the cabinet is greater than 800 watts, then forced convection must be used.
-

---

## Using the HP 70810B Lightwave Section

This user's guide provides installation, troubleshooting, operation, and programming details for a lightwave section that has been configured as an independent element (stand-alone operation).

An HP 70810B lightwave section can also be configured for operation as a slave element in a modular lightwave signal analyzer. When configured as a slave element, a lightwave section is part of an HP 71400C or HP 71401C lightwave signal analyzer. For system-level configuration information, refer to the *HP 70000 Modular Spectrum Analyzer Installation and Verification Manual* for HP 70900B local-oscillator-controlled modules.

An HP 70810A lightwave section cannot be configured as a slave element.

---

## **Assistance**

Product maintenance agreements and other customer assistance agreements are available for Hewlett-Packard products. For any assistance, contact your nearest Hewlett-Packard sales and service office.

---

## **Certification**

Hewlett-Packard Company certifies that this product met its published specifications at the time of shipment from the factory. Hewlett-Packard further certifies that its calibration measurements are traceable to the United States National Institute of Standards and Technology, to the extent allowed by the Institute's calibration facility, and to the calibration facilities of other International Standards Organization members.

---

## Warranty

This Hewlett-Packard instrument product is warranted against defects in material and workmanship for a period of one year from date of shipment. During the warranty period, Hewlett-Packard Company will, at its option, either repair or replace products which prove to be defective.

For warranty service or repair, this product must be returned to a service facility designated by Hewlett-Packard. Buyer shall prepay shipping charges to Hewlett-Packard and Hewlett-Packard shall pay shipping charges to return the product to Buyer. However, Buyer shall pay all shipping charges, duties, and taxes for products returned to Hewlett-Packard from another country.

Hewlett-Packard warrants that its software and firmware designated by Hewlett-Packard for use with an instrument will execute its programming instructions when properly installed on that instrument. Hewlett-Packard does not warrant that the operation of the instrument, or software, or firmware will be uninterrupted or error-free.

### LIMITATION OF WARRANTY

The foregoing warranty shall not apply to defects resulting from improper or inadequate maintenance by Buyer, Buyer-supplied software or interfacing, unauthorized modification or misuse, operation outside of the environmental specifications for the product, or improper site preparation or maintenance.

NO OTHER WARRANTY IS EXPRESSED OR IMPLIED.  
HEWLETT-PACKARD SPECIFICALLY DISCLAIMS THE IMPLIED WARRANTIES OF MERCHANTABILITY AND FITNESS FOR A PARTICULAR PURPOSE.

### EXCLUSIVE REMEDIES

THE REMEDIES PROVIDED HEREIN ARE BUYER'S SOLE AND EXCLUSIVE REMEDIES. HEWLETT-PACKARD SHALL NOT BE LIABLE FOR ANY DIRECT, INDIRECT, SPECIAL, INCIDENTAL, OR CONSEQUENTIAL DAMAGES, WHETHER BASED ON CONTRACT, TORT, OR ANY OTHER LEGAL THEORY.

---

## Instrument Markings



The instruction documentation symbol. The product is marked with this symbol when it is necessary for the user to refer to the instructions in the documentation.

“CE”

The CE mark is a registered trademark of the European Community. (If accompanied by a year, it is when the design was proven.)

“ISM1-A”

This is a symbol of an Industrial Scientific and Medical Group 1 Class A product.

“CSA”

The CSA mark is a registered trademark of the Canadian Standards Association.

---

## Warnings

### Caution

---

*Caution* denotes a hazard. It calls attention to a procedure that, if not correctly performed or adhered to, could result in damage to or destruction of the instrument. Do not proceed beyond a *caution* note until the indicated conditions are fully understood and met.

---

### Warning

---

***Warning* denotes a hazard. It calls attention to a procedure that, if not correctly performed or adhered to, could result in injury or loss of life. Do not proceed beyond a *warning* note until the indicated conditions are fully understood and met.**

---

---

## Key Conventions

**Front-panel key**

Text shown like this represents a key physically located on the spectrum analyzer.

**Softkey**

Text shown like this represents a softkey. (The softkeys are located next to the softkey labels, and the softkey labels are the annotation on the right or left side of the spectrum analyzer display.)

**Input Text**

Text printed in this typeface indicates text you enter via the keypad or using programming commands.

**Message Text**

Text printed in this typeface indicates text displayed on the instrument's screen.

---

## What You'll Find in This Manual

- Chapter 1** “Getting Started,” describes the HP 70810B lightwave section and shows you how to install it.
- Chapter 2** “System Verification,” shows you how to verify basic lightwave section functions.
- Chapter 3** “Operating,” describes how to operate a lightwave section that has been configured for stand-alone operation.
- Chapter 4** “Programming,” describes how to operate a lightwave section by remote computer control.
- Chapter 5** “Specifications and Characteristics,” contains the module specifications for the HP 70180B and HP 70810B Option 850 lightwave sections, and any required regulatory information.
- Chapter 6** “Menu Maps,” illustrates the display menu organization for the lightwave section softkeys.
- Chapter 7** “Dictionary Reference,” contains a description of softkeys and front- and rear-panel features and connectors.
- Chapter 8** “Programming Commands,” describes the syntax, parameters, and functions of the commands used to operate an HP 70810B or HP 70810B Option 850 lightwave section as a stand-alone lightwave receiver.
- Chapter 9** “Error Messages,” provides module-level troubleshooting information for an HP 70810B or HP 70810B Option 850 lightwave section when it is configured for stand-alone operation.
- Chapter 10** “Tables and Charts,” lists options and accessories and tells you how to contact an HP sales and service office.
- Chapter 11** “Configuring and Addressing,” explains how to address one or more HP 70810B lightwave sections for stand-alone operation and provides general addressing information for modular measurement systems.



# Contents

---

<b>1. Getting Started</b>	
What You'll Find in This Chapter . . . . .	1-1
Introducing the Lightwave Section . . . . .	1-2
Lightwave Section Serial Numbers . . . . .	1-3
Installing the Lightwave Section for Stand-Alone Operation . . . . .	1-4
To install the HP 70810B module . . . . .	1-5
To remove the HP 70810B module . . . . .	1-6
Changing Measurement Parameters with an HP 71400C or HP 71401C . . . . .	1-7
Caring for Optical Connectors . . . . .	1-8
Cleaning Optical Connectors . . . . .	1-8
Reducing Electrostatic Discharge (ESD) Damage . . . . .	1-9
PC Board Assemblies and Electronic Components . . . . .	1-9
Test Equipment . . . . .	1-10
Static-Safe Accessories . . . . .	1-10
Servicing Your Module Using the HP 71000 System Service Kit . . . . .	1-11
Returning the Module for Service . . . . .	1-12
To return a module for service . . . . .	1-12
<b>2. System Verification</b>	
What You'll Find in This Chapter . . . . .	2-1
Verifying Basic Functions . . . . .	2-2
To verify basic functionality . . . . .	2-2
<b>3. Operating</b>	
What You'll Find in This Chapter . . . . .	3-1
An Overview of Operation . . . . .	3-2
Calibration . . . . .	3-2
Display Annotation . . . . .	3-3
Display Front-Panel Keys . . . . .	3-5
An Overview of Softkeys . . . . .	3-6
Using the Front Panel to Enter Data . . . . .	3-6
Front-Panel and Rear-Panel Features . . . . .	3-7
Front-Panel LEDs . . . . .	3-7
Connectors and Latches . . . . .	3-8
Cleaning Connections for Accurate Measurements . . . . .	3-9
To clean a dry connector . . . . .	3-9
To clean a wet connector . . . . .	3-10
To apply index-matching compound . . . . .	3-10

<b>4. Programming</b>	
What You'll Find in This Chapter . . . . .	4-1
Getting Set Up for Remote Operation . . . . .	4-2
Communicating with the Lightwave Section . . . . .	4-3
Executing Remote Commands . . . . .	4-3
Syntax Requirements . . . . .	4-4
Local and Remote Control . . . . .	4-4
Initial Program Considerations . . . . .	4-5
Transferring Data to the Computer . . . . .	4-6
Requesting and Receiving Data . . . . .	4-6
Monitoring System Operation . . . . .	4-8
Interrupt Process . . . . .	4-8
Lightwave Section Status Byte . . . . .	4-9
The Service-Request Mask . . . . .	4-9
Service-Request Examples . . . . .	4-10
Monitoring System Operation without Using Service Requests . . . . .	4-11
<b>5. Specifications and Characteristics</b>	
What You'll Find in This Chapter . . . . .	5-1
Configuration Modes . . . . .	5-2
HP 70810B Module Specifications . . . . .	5-3
HP 70810B Option 850 Module Specifications . . . . .	5-6
Module Input and Output Characteristics . . . . .	5-10
Lightwave Input . . . . .	5-10
RF Input . . . . .	5-10
RF Output . . . . .	5-10
HSWP In/Out . . . . .	5-10
<b>6. Menu Maps</b>	
What You'll Find in This Chapter . . . . .	6-1
<b>7. Dictionary Reference</b>	
What You'll Find in This Chapter . . . . .	7-1
Alphabetical Listing of Softkeys, Connectors, and Latches . . . . .	7-2
<b>8. Programming Commands</b>	
What You'll Find in This Chapter . . . . .	8-1
Syntax Conventions . . . . .	8-2
Pictorial Notation . . . . .	8-2
Text Notation . . . . .	8-2
Command Sequence . . . . .	8-2
Syntax Summary . . . . .	8-3
Query Responses . . . . .	8-4
Common Command Parameters . . . . .	8-5
AUNITS . . . . .	8-10
CAL . . . . .	8-11
CALCOR . . . . .	8-12
DONE . . . . .	8-13
ERR . . . . .	8-14
HD . . . . .	8-15
ID . . . . .	8-16
IP . . . . .	8-17
LTWAVE . . . . .	8-18
MSG . . . . .	8-19

OPTATN . . . . .	8-21
OPTCOR . . . . .	8-22
OPTPWR . . . . .	8-24
REV . . . . .	8-25
RQS . . . . .	8-26
RSPSVTY . . . . .	8-28
SER . . . . .	8-29
SRQ . . . . .	8-30
STB . . . . .	8-32
TEST . . . . .	8-34
USERMSG . . . . .	8-35
XERR . . . . .	8-36
ZERO . . . . .	8-38

**9. Error Messages**

What You'll Find in This Chapter . . . . .	9-1
Troubleshooting Features . . . . .	9-2
Display Status Indicators . . . . .	9-2
Lightwave Section Status Indicators . . . . .	9-2
Status Error Indicators . . . . .	9-2
Active Indicators . . . . .	9-3
Catastrophic Failures . . . . .	9-4
Troubleshooting a Lightwave Section . . . . .	9-5
Error Message Descriptions . . . . .	9-6
Operating Errors 2000 to 2999 . . . . .	9-6
2001 Illegal command . . . . .	9-6
2003 Missing parameter . . . . .	9-6
2006 Parm out of range . . . . .	9-7
2011 Memory overflow . . . . .	9-7
2018 State protected . . . . .	9-7
2023 Illegal Cal signal . . . . .	9-7
2031 Too many errors . . . . .	9-7
2032 Hardware not present . . . . .	9-7
2035 Illegal operation . . . . .	9-7
2802 Illegal in LW mode . . . . .	9-8
2803 Illegal in bypass . . . . .	9-8
Computation Errors 4000 to 4999 . . . . .	9-8
4000 Divide by zero . . . . .	9-8
4001 Float overflow . . . . .	9-8
4002 Float underflow . . . . .	9-8
4003 Logarithm error . . . . .	9-8
4004 Integer overflow . . . . .	9-8
4005 Square root error . . . . .	9-8
Hardware Warning Errors 6000 to 6999 . . . . .	9-8
6802 Invalid cal data . . . . .	9-8
6805 Firmware changed . . . . .	9-9
6806 Avg pwr over-range . . . . .	9-9
Hardware-Broken Errors 7000 to 7999 . . . . .	9-9
7801 Optical atten failed . . . . .	9-9
7802 ADC error . . . . .	9-9
7803 Power meter failed . . . . .	9-9
7804 Self test failed . . . . .	9-9
7805 Zeroing error . . . . .	9-9
Factory-Use Only Errors 9000 to 9999 . . . . .	9-10

<b>10. Tables and Charts</b>	
What You'll Find in This Chapter . . . . .	10-1
Instrument Options . . . . .	10-2
Accessories Supplied with the Product . . . . .	10-2
Service Kit Accessories . . . . .	10-3
Contacting HP Sales and Service Offices . . . . .	10-4
<b>11. Configuring and Addressing</b>	
What You'll Find in This Chapter . . . . .	11-1
HP-MSIB and HP-IB Addressing . . . . .	11-2
Modular Measurement System Terminology . . . . .	11-3
Functional Terms . . . . .	11-3
Structural Terms . . . . .	11-3
Address Matrix . . . . .	11-4
HP-IB Access Area . . . . .	11-4
Display-Response Area . . . . .	11-4
Display Communication Capabilities . . . . .	11-5
Address Switches . . . . .	11-6
HP 70810B Address Switches . . . . .	11-6
Soft-Set HP-IB Addresses . . . . .	11-6
Default Address . . . . .	11-6
Address Map for Stand-Alone Operation . . . . .	11-8

**Index**

## Figures

---

1-1. Typical Serial Number Label . . . . .	1-3
1-2. Module Removal/Replacement . . . . .	1-5
1-3. HP 70810B Address Switch Position for Stand-Alone Operation . . . . .	1-6
1-4. Static-Safe Workstation . . . . .	1-9
2-1. Initial Operation Test Equipment Setup . . . . .	2-2
2-2. Average Power Display from an HP 70810B in Stand-Alone Operation . . . . .	2-3
2-3. Spectrum Analyzer Display of Modulation Spectrum . . . . .	2-4
3-1. Display Annotation for Stand-Alone Operation . . . . .	3-3
3-2. HP 70810B Front Panel and Rear Panel . . . . .	3-7
6-1. Softkey Menu Map for Stand-Alone Operation . . . . .	6-2
8-1. Numeric Value Query Response . . . . .	8-4
8-2. Binary State Query Response . . . . .	8-4
11-1. The Address Matrix . . . . .	11-4
11-2. Typical HP 70810B Address Switch . . . . .	11-7
11-3. Address Map for Multiple Lightwave Sections . . . . .	11-8

## Tables

---

1-1. Static-Safe Accessories . . . . .	1-10
4-1. Units for Returned Data . . . . .	4-6
4-2. Lightwave Section Status Byte . . . . .	4-10
5-1. HP 70810B Specifications and Characteristics (1 of 2) . . . . .	5-4
5-1. HP 70810B Specifications and Characteristics (2 of 2) . . . . .	5-5
5-2. HP 70810B Option 850 Specifications and Characteristics (1 of 2) . . . . .	5-7
5-2. HP 70810B Option 850 Specifications and Characteristics (2 of 2) . . . . .	5-8
5-3. HP 70810B and HP 70810B Option 850 General Specifications and Characteristics . . . . .	5-9
8-1. Commands by Functional Group . . . . .	8-7
8-2. Alphabetical Command Summary . . . . .	8-8
8-3. Programming Commands Executed or Affected by Instrument Preset . . . . .	8-17
8-4. Lightwave Section Status Byte . . . . .	8-27
8-5. Lightwave Section Status Byte . . . . .	8-31
8-6. Lightwave Section Status Byte . . . . .	8-33
10-1. Accessories Shipped with the HP 70810B . . . . .	10-2
10-2. HP 71000 System Service Kit (HP Part Number 71000-60002) . . . . .	10-3
10-3. Hewlett-Packard Sales and Service Offices . . . . .	10-5

11-1. Decimal Equivalent of Binary Address . . . . . 11-4

# Getting Started

---

This chapter describes the HP 70810B lightwave section and shows you how to install it.

---

## What You'll Find in This Chapter

- Introducing the Lightwave Sections ..... page 1-2
- Installing the Lightwave Section for Stand-Alone Operation page 1-4
- Changing Measurement Parameters with an HP 71400C or HP 71401C ..... page 1-7
- Caring for Optical Connectors ..... page 1-8
- Reducing Electrostatic Discharge (ESD) Damage ..... page 1-9
- Servicing Your Module Using the HP 71000 Service Kit .... page 1-11
- Returning the Module for Service ..... page 1-12

---

### Note

When operated as a slave element, the HP 70810B lightwave section requires an HP 70900B local oscillator module with firmware date code 911021 or later for proper operation.

---

---

## Introducing the Lightwave Section

HP 70810B and HP 70810B Option 850 lightwave sections are 1/8-width modules designed to work in an HP 70000 modular measurement system mainframe. They both have Hewlett-Packard Interface Bus (HP-IB) and Hewlett-Packard Modular System Interface Bus (HP-MSIB) communication capabilities. Either lightwave section can function in the following configurations:

- As a stand-alone instrument that will measure average optical power and provide an amplified electrical signal output corresponding to the intensity-modulated signal level.
- As a lightwave signal analyzer with a 22 GHz modulation bandwidth capability and calibrated system response (HP 71400C lightwave signal analyzer system).
- As a lightwave signal analyzer with a 2.9 GHz modulation bandwidth capability and calibrated system response (HP 71401C lightwave signal analyzer).

The HP 70810B lightwave section provides a wavelength measurement range of 1200 nm to 1600 nm (750 nm to 870 nm for an Option 850) and a detected modulation bandwidth of 100 kHz to 22 GHz with an input noise equivalent power of  $-64 \text{ dBm}/\sqrt{\text{Hz}}$ . Lightwave section features include HP-IB and HP-MSIB communication capability, optical and electrical input connectors, and a module-control processor that provides either slave or stand-alone module capability.

Typically, the HP 70810B precedes the RF section in a modular electrical spectrum analyzer, such as an HP 71210C microwave or an HP 71100C RF spectrum analyzer. An electrical spectrum analyzer configured with an HP 70810B lightwave section is a lightwave signal analyzer. The lightwave system detects and displays intensity modulation present on a lightwave signal transmitted on single-mode optical fiber. The displayed intensity-modulation incorporates frequency-response calibration corrections that compensate for photodetector responsivity and preamplifier gain variations. The factory determines responsivity values for 1300 nm and 1550 nm wavelengths (850 nm for an Option 850). The user can select one of these values or calibrate the lightwave section to some other reference.

Basically the HP 70810B consists of optical attenuator, broadband photodetector, microwave preamplifier, and optical power meter. The filter-wheel attenuator provides up to 30 dB of optical attenuation programmed in 1 dB steps. A lens focuses the light onto a high-speed PIN photodetector, which detects the modulation and converts optical power to electrical current (photons to electrons). One path for the detected current drives the high-gain, low noise, four-stage preamplifier, which consists of four traveling-wave GaAs MMICs (gallium-arsenide microwave-monolithic integrated circuit).

The lightwave section preamplifier typically provides 32 dB gain and an 8 dB noise figure from 100 kHz to 22 GHz. A second path monitors the detected current's DC component with a transimpedance



circuit, which determines a value representing average optical power. The average power value appears on the display as both a real-time vertical power bar and a digital power readout.

In a stand-alone configuration, the lightwave section functions as an optical detector and average power meter. When lightwave mode is selected, the lightwave section produces an electrical output that is the amplified, uncorrected, detected intensity modulation of a modulated optical input signal. The lightwave section also has an RF input for conventional RF signal inputs. When RF bypass mode is selected, the RF input is connected directly to the RF output, bypassing the preamplifier and all optical hardware. A spectrum analyzer or other electrical measurement instrument must be connected to the RF output to make use of the electrical output signal produced in either lightwave or RF bypass mode.

An important feature of the HP 70810B is its versatile input connector system. A variety of screw-on optical connector interface options are now available, such as:

- Diamond HMS-10/HP
- FC/PC
- DIN 47256
- Biconic
- ST

Patch cords are also available that accommodate other optical connector systems, such as the Radiall. Contact your local Hewlett-Packard sales and service office for information about the latest lightwave measurement accessories.

## Lightwave Section Serial Numbers

A two-part serial number appears on the mylar label attached to the front frame of the lightwave section. The first four digits and the letter are the serial number prefix; the last five digits, the suffix. (See Figure 1-1.) Identical lightwave sections have the same prefix, which changes only for significant modification. The suffix is different for each lightwave section.

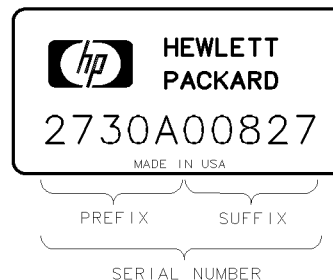

PBB1

**Figure 1-1. Typical Serial Number Label**

---

## Installing the Lightwave Section for Stand-Alone Operation

This section tells you how to install the HP 70810B lightwave section in an HP 70000 modular measurement system mainframe. When the HP 70810B is shipped as part of an HP 71400C or HP 71401C lightwave signal analyzer, the factory addresses and interconnects all system components. Refer to the *HP 70000 Modular Spectrum Analyzer Installation and Verification Manual for HP 70900B Local-Oscillator Controlled Modules* for system-level information.

Any future shipment of the instrument requires the original packing materials or their equivalents. For detailed packing and shipping information, refer to “Returning the Module for Service” in this chapter.

## To install the HP 70810B module

1. Inspect the shipping container or cushioning material for damage.  
If there is damage or a defect, save the packing materials, file a claim with the carrier, then contact the nearest Hewlett-Packard sales and service office for immediate repair or replacement.
2. Set the mainframe LINE switch to OFF, then swing down the front door. See Figure 1-2.

---

### Note

The lightwave section row address must be set to zero for stand-alone operation. The column address can be set to any value greater than the column address of the display. The highest column address that can be used is 30. A default column address of 20 is used throughout this manual.

When the HP 70810B is part of a system, the default row address is 3 and the default column address is 20.

---

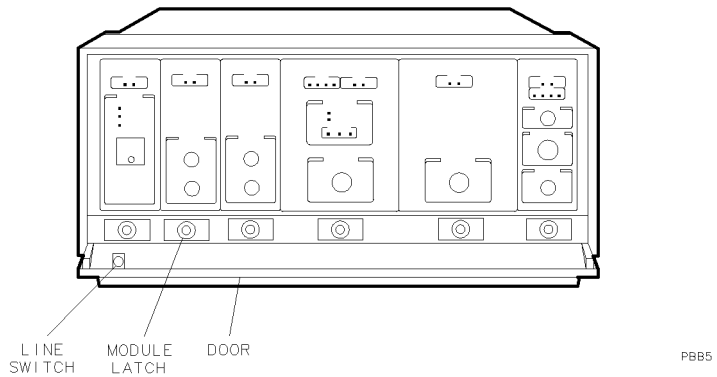

**Figure 1-2. Module Removal/Replacement**

3. Set the lightwave section HP-MSIB address to column 20, row 0.  
Refer to Figure 1-3 for the correct address switch position.

---

### Note

The four-section switch at the top of Figure 1-3 has no effect on stand-alone operation.

---

4. Set the HP-IB switch to ON for stand-alone operation.
5. Slide the lightwave section into the mainframe, push firmly on the front panel, and tighten the module latch using the 8 mm hex-ball driver.

---

### Note

Stand-alone operation does not require an external cable connection at rear-panel HSWP connector.

---

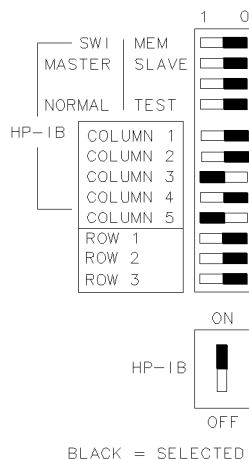

PBB6

**Figure 1-3.**  
**HP 70810B Address Switch Position for Stand-Alone Operation**

6. Set the mainframe LINE switch to ON.
7. Verify that the mainframe power indicator is on and that the ventilation fan is working.
8. After the lightwave section softkeys have appeared, the lightwave section is ready for use.

If the lightwave section menu softkeys do not appear after power-up, the display window probably is not assigned to the lightwave section. To assign it, perform the following steps:

- a. Press the **DISPLAY** key on the display front panel to access the main menu for the display.
  - b. Press the **NEXT INSTR** softkey until the lightwave section is selected for independent operation.
  - c. Press the **MENU** key to display the seven softkeys for stand-alone operation of the lightwave section.
9. Refer to Chapter 2 to verify operation of the lightwave section.

During a normal power-on sequence, a self-test routine causes the various lightwave section LEDs to turn on and off. If the HP 70810B ERR LED remains on after the test, refer to Chapter 9 for a description of the displayed error messages.

### To remove the HP 70810B module

1. Set the instrument LINE switch to OFF. If a coaxial cable is attached to the high-sweep connector on the rear panel, remove it.
2. Swing down the front door, then use the 8 mm hex-ball driver to loosen the module latch.
3. Slide the module out of the mainframe.

## Changing Measurement Parameters with an HP 71400C or HP 71401C

Use the front-panel knob, step keys, or numeric keypad to enter new measurements settings. For example, press the **ATTEN** softkey to change the optical input attenuation. After changing the setting, pressing the **(HOLD)** key disables the keypad, knob, and step keys until another function is selected. Pressing the **(HOLD)** key twice blanks the right-side softkeys.

Use the **(←)** (backspace) key to speed your navigation through softkey menus. When pressed, the previous softkey menu is displayed. Also, use this key to backspace over numbers entered using the data-entry keypad.

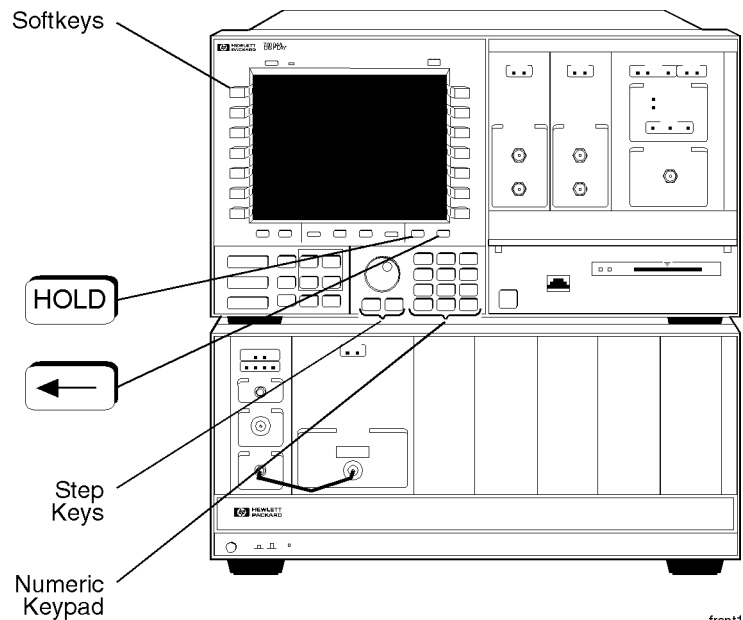

front1

**HP 71400C/HP 71401C**

---

## Caring for Optical Connectors

### Warning

---

**To avoid the possibility of damage to your eyes, verify a disabled output at the light source before any cleaning, connecting, or disconnecting of optical system components.**

---

The HP 70810B options include various optical input connector interfaces. Also available are patch cords that accommodate additional optical connector systems. The connectors and patch cords screw on finger-tight to the lightwave section front-panel optical input fitting. An optical cable from the light source attaches to the connector interface or patch cord.

Both the lightwave section front-panel fitting and the source cable have a protruding fiber-optic tip. In the center of this tip is the actual glass fiber. Lightwave measurements demand precision mating of flawless fiber ends. Thus the delicate glass fiber requires protection from mechanical damage, fingerprints, and obstructions.

### Caution

---

The following precautions help prevent fiber damage and help assure accurate light measurements.

- Exposed fiber-optic tips are easily scratched. Do not allow any object to touch an unprotected tip. This precaution is particularly important when installing a connector interface and when making and breaking connections.
  - Never insert any cleaning tool into an optical connector ferrule; this may cause damage that can affect the optical system.
  - Do not touch an exposed fiber-optic tip. An oily fingerprint requires cleaning with cleaning solution.
  - Before *any* mating of fiber-optic tips, clean the tips with isopropyl alcohol and a cotton swab.
  - Clean more thoroughly with cleaning solution if measurements reveal a slightly lower than expected power level or an increase in reflections or intensity noise.
  - Always replace the protector caps on any exposed fiber-optic tip.
- 

## Cleaning Optical Connectors

Refer to “Cleaning Connections for Accurate Measurements” in Chapter 3 for optical connector cleaning information.

---

## Reducing Electrostatic Discharge (ESD) Damage

### Caution

ESD can damage or destroy electronic components. Work at static-safe workstations when servicing assemblies consisting of electronic components.

---

Figure 1-4 shows an example of a static-safe workstation with two combinations of ESD protection: conductive table mat with wrist strap; conductive floor mat with heel strap. Use these two combinations together. The “Static-Safe Accessories” section provides lists of accessories.

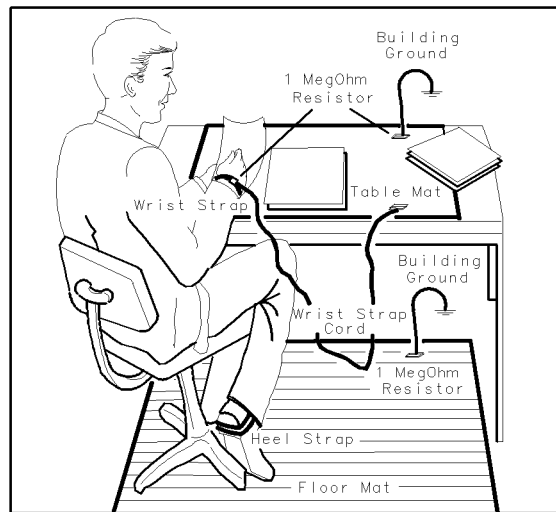

PBB4

**Figure 1-4. Static-Safe Workstation**

The following suggestions help reduce ESD damage that can occur during instrument test and service.

### PC Board Assemblies and Electronic Components

- Work at a static-safe workstation.
- Store or transport in static-shielding containers.
- Do not use erasers to clean edge connector contacts. Erasers generate static electricity and remove gold plating. Clean with lint-free cloth and a solution of 80% electronics-grade isopropyl alcohol and 20% deionized water.

## Test Equipment

- Before connecting any coaxial cable to an instrument for the first time each day, momentarily short together the center and outer conductors of the cable.
- Before touching the center pin of any connector, make sure you are using a grounded, resistor-isolated, wrist strap.
- To prevent buildup of static charge, make sure all instruments are properly earth-grounded.

## Static-Safe Accessories

Table 1-1 lists static-safe accessories that you can order through any Hewlett-Packard sales and service office.

**Table 1-1. Static-Safe Accessories**

<b>HP Part Number</b>	<b>Description</b>
9300-0797	Set includes: 3M static control mat 0.6 m × 1.2 m (2 ft × 4 ft) and 4.6 cm (15 ft) ground wire. (The wrist-strap and wrist-strap cord are not included; they must be ordered separately.)
9300-0980	Wrist-strap cord 1.5 m (5 ft)
9300-1383	Wrist-strap, color black, stainless steel, without cord, has four adjustable links and a 7 mm post-type connection.
9300-1169	ESD heel-strap (reusable 6 to 12 months).



---

## **Servicing Your Module Using the HP 71000 System Service Kit**

The HP 71000 system service kit (HP part number 71000-60002) is the general service kit for HP 70000 Series modules. This kit includes servicing tools required to repair all HP 70000 Series modules and also a modification procedure for the HP 70001A mainframe. The modification allows access to HP 70000 Series modules during bench testing and repair. Refer to the latest version of service note 71000A-1 for a full listing of the HP 71000 system service kit contents.

---

## Returning the Module for Service

Repackaging a module requires the original shipping containers and materials or their equivalents. Hewlett-Packard offices can provide packaging materials identical to the original materials. Refer to Chapter 10 for the Hewlett-Packard sales and service office nearest you.

### Caution

---

Packaging materials not specified can result in instrument damage. Never use styrene pellets to package electronic instruments. The pellets do not adequately cushion the instrument, do not prevent all instrument movement, and can generate static electricity.

---

### To return a module for service

1. Fill out a blue repair card (located at the end of this chapter) and attach it to the instrument. Send a copy of any noted error messages or other helpful performance data. If a blue repair card is *not* available, include at least the following information:
  - a. Type of service required
  - b. Description of the problem and whether it is constant or intermittent
  - c. Name and telephone number of technical contact person
  - d. Return address
  - e. Model number of returned instrument
  - f. Full serial number of returned instrument
  - g. List of any accessories returned with instrument
2. To help prevent damage during transit, pack the instrument in the factory packaging materials. Original shipping materials or equivalents are best; however, the following instructions result in acceptable packaging.
  - a. Wrap the instrument in anti-static plastic to reduce the possibility of ESD damage.
  - b. For instruments that weigh less than 54 kg (120 lb), use a double-walled, corrugated cardboard carton of 159 kg (350 lb) test strength. The carton must be both large enough and strong enough to accommodate the instrument. Allow at least three to four inches on all sides of the instrument for packing material.
  - c. Surround the equipment with three to four inches of packing material to protect the module and to prevent movement in the carton. If packing foam is not available, the best alternative is S.D.-240 Air Cap™ from Sealed Air Corporation, Hayward, California 94545. Air Cap is plastic sheeting filled with 1-1/4 inch air bubbles. Use pink anti-static Air Cap. Wrapping the instrument several times in this material should provide sufficient protection and also prevent movement in the carton.
3. Seal the carton with strong nylon adhesive tape.
4. Mark the carton FRAGILE, HANDLE WITH CARE.
5. Retain copies of all shipping papers.

# System Verification

---

This chapter shows you how to verify basic lightwave section functions.

---

## What You'll Find in This Chapter

Verifying Basic Functions ..... page 2-2

## Verifying Basic Functions

Because of specialized and expensive test-equipment requirements, this chapter does not contain software-supported procedures needed to verify module specifications. This chapter does provide a procedure that verifies the basic functionality of the HP 70810B optical average power meter, optical to electrical converter, and optical attenuator in HP 70810B stand-alone mode.

The spectrum analyzer illustrated in Figure 2-1 is an HP 70000 modular spectrum analyzer with a calibrator output of 300 MHz at  $-10$  dBm. The calibrator output is used as the modulation source for the verification test. Any equivalent spectrum analyzer can be used.

The laser and power supply shown in Figure 2-1 may be substituted with any modulatable laser.

If the lightwave section fails any one of the verification tests, contact your local Hewlett-Packard service office. The procedure for returning and instrument for service is described in "Returning the Module for Service" in Chapter 1

### To verify basic functionality

1. Connect the test equipment as shown in Figure 2-1.

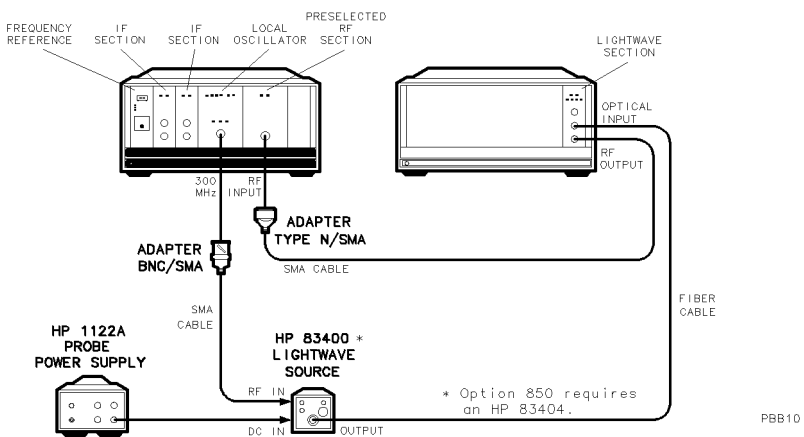

**Figure 2-1. Initial Operation Test Equipment Setup**

2. Check the power-bar display for the HP 70810B in stand-alone mode. The display should be similar to that illustrated in Figure 2-2.

The figure illustrates the optical average power reading displayed as a power-bar graphic and an annotated readout. If the display does not match Figure 2-2, press **[F-P]** on the display controlling the HP 70810B and recheck the test setup. If the power bar response is absent or low, the lightwave section may be defective. Clean the optical connectors and verify that single-mode optical fiber is used.

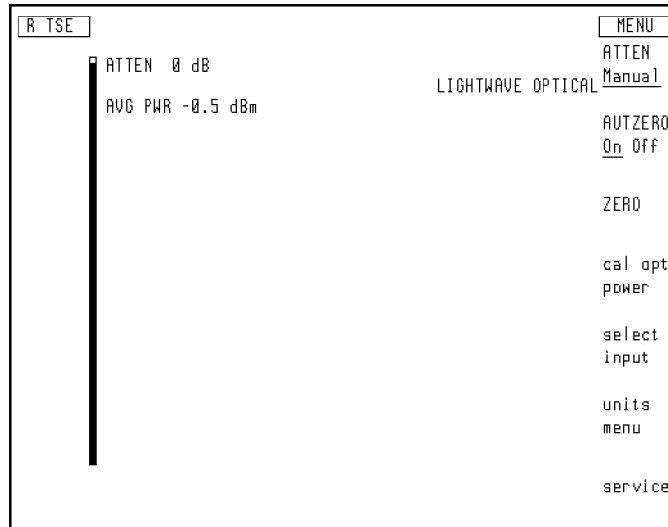

**Figure 2-2.**  
Average Power Display from an HP 70810B in Stand-Alone Operation

3. Perform the calibration procedure for an optical power meter.
4. Using the calibrated optical power meter, calibrate the intensity of the lightwave source.
5. Compare the optical power levels measured by the optical power meter and the HP 70810B lightwave section. Any differences between the measured levels should be less than that which is listed in Chapter 5.
6. To observe the detection of a modulated optical signal, set the spectrum analyzer to a center frequency of 300 MHz and a span of 100 MHz. The analyzer should display a signal at 300 MHz.

The signal represents the uncalibrated modulation power. The analyzer display should be similar to that illustrated in Figure 2-3. If it is not, perform an instrument preset for the HP 70810B, recheck the test setup and instrument settings. If no signal is displayed at the modulation frequency, the lightwave section is probably defective.

7. To check the operation of the optical attenuator, press `ATTEN Manual` and set the optical attenuator to 5 dB.

The signal level displayed on the spectrum analyzer should drop by approximately 10 dB. (A 1 dB change in the optical attenuator setting causes a 2 dB change in the signal level displayed on the spectrum analyzer.) If the spectrum analyzer signal level does not respond correctly to a change in optical attenuation, the lightwave section is defective.

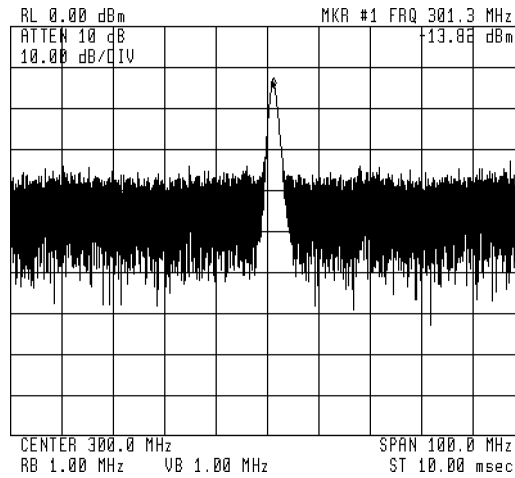

**Figure 2-3. Spectrum Analyzer Display of Modulation Spectrum**

## Operating

---

This chapter describes how to operate a lightwave section that has been configured for stand-alone operation only. For information about operating a lightwave signal analyzer system, refer to the *HP 70000 Modular Spectrum Analyzer Operation Manual for HP 70900B Local-Oscillator-Controlled Modules*.

---

### What You'll Find in This Chapter

An Overview of Operation .....	page 3-2
Display Front-Panel Keys .....	page 3-5
An Overview of Softkeys .....	page 3-6
Front-Panel and Rear-Panel Features .....	page 3-7
Cleaning Connections for Accurate Measurements .....	page 3-9

---

## An Overview of Operation

In stand-alone configuration for the lightwave section, there are two modes of operation.

- **Lightwave mode** enables the optical detector and preamplifier, and calibrates the average power in optical units.
- **RF signal bypass mode** enables the lightwave section to pass an RF signal through its RF INPUT and route it directly to the RF OUTPUT.

An intensity-modulated 1200 nm to 1600 nm (750 nm to 870 nm for an Option 850) lightwave signal on a single-mode fiber can be directly applied to the optical input. The intensity-modulated optical power can be detected, as well as the average optical power.

In lightwave mode, the optical input is detected by a high-speed PIN photodetector. The modulated portion of the input is then amplified by a microwave traveling-wave amplifier and passed to the RF output. The gain of this amplifier overcomes the noise figure of electrical measurement instruments connected to the RF output, which yields excellent sensitivity. The detected average component of optical power is amplified by a transimpedance amplifier and is displayed on-screen as a power bar.

The system is internally calibrated at two optical wavelengths in a standard lightwave section, 1300 nm and 1550 nm, and at 850 nm in an Option 850. A user calibration feature also allows calibration to an external reference over the 1200 nm to 1600 nm wavelength range. In addition, the built-in optical attenuator allows operation over a wide dynamic range.

In RF bypass mode, the PIN photodetector and preamplifier are bypassed so that an electrical signal is passed directly from the lightwave section RF INPUT to the RF OUTPUT of the lightwave section. This lets you make electrical power measurements directly from the RF INPUT on the lightwave section.

---

### Note

You may use the instrument preset (P) key on the display front panel at any time to return the instrument to a power-on state where all operating parameters are reset.

---

### Calibration

The lightwave section has been calibrated as part of the manufacturing process and does not require routine calibration by the user. All specifications apply after the module temperature has stabilized. A warmup period of 30 minutes following turn-on is adequate for temperature stabilization. We recommend you have the module recalibrated by Hewlett-Packard at 12-month intervals.



## Display Annotation

You will find display annotation to be helpful when making measurements from the front panel of the instrument. The display annotation provides information about the current state of the lightwave section. Refer to Figure 3-1 for information on the kinds of display annotation that are available.

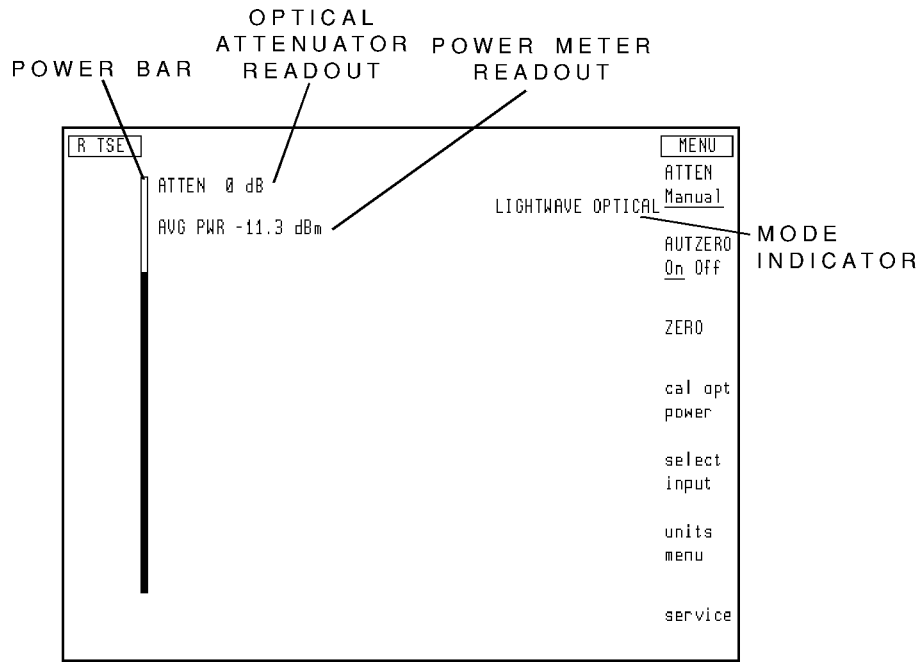

### ZEROING INDICATOR

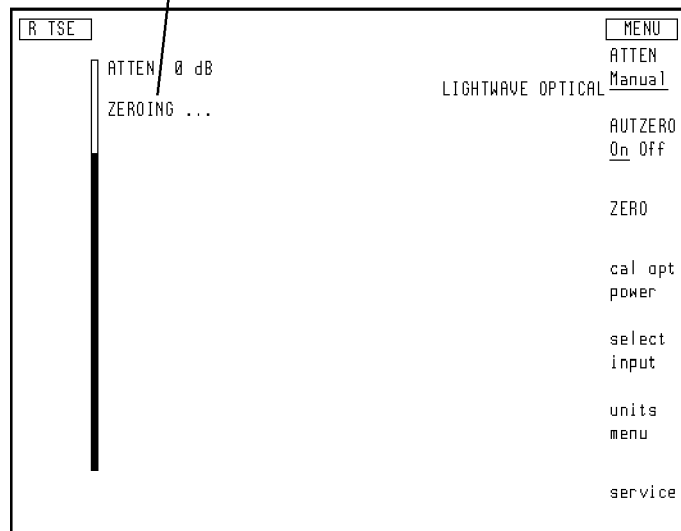

Figure 3-1. Display Annotation for Stand-Alone Operation

- Optical attenuator** indicates the current optical attenuator setting in optical power units. Use the **ATTEN Manual** softkey to change the optical attenuator setting.
- Power meter readout** provides the current average power meter readout annotated in optical dBm or watts units. Use the units menu softkeys to change the display annotation.
- Mode indicator** indicates whether the lightwave section is in lightwave or RF bypass mode. Use the **select input** softkey to change modes.
- Power bar** provides a visual display of the average optical power measured by the power meter.
- Zeroing indicator** is displayed while offsets in the power meter are being zeroed in either automatic or manual zeroing mode. Use the **ZERO** softkey function to zero the power meter manually.

Refer to the section “An Overview of Softkeys” for information about softkey operation.

---

## Display Front-Panel Keys

The display front-panel **DISPLAY** and **MENU** keys provide access to the two different types of softkey menus. Pressing either key at any time automatically selects the menu structure for the respective key. A third display front-panel key, the **USER** key, is not implemented for stand-alone operation.

The **DISPLAY** key selects the Display Main Menu, which allows access to all display functions. Refer to the operation manual for the display.

The **MENU** key selects the softkey function menu for the lightwave section. When the menu softkey is first pressed, seven softkeys appear at the right-hand side of the display screen. These softkeys perform the most frequently used functions and provide access to the next level of softkeys.

If no other instruments are installed in the mainframe or display, the softkey menu for stand-alone operation appears when the mainframe and display are switched on.

If other instruments are installed in the mainframe or display and the lightwave section is configured for stand-alone operation, the lightwave section must first be selected with the **NEXT INSTR** softkey via the **DISPLAY** key. After the lightwave section has been selected, the softkey menu appears, and the section operates as an independent element in stand-alone mode.

---

## An Overview of Softkeys

The softkeys selected by the **MENU** key allow access to all of the lightwave section functions. A softkey is designated by the following convention: softkey.

All softkeys designated by lowercase letters indicate that a sub-level softkey menu exists beyond that particular softkey. Uppercase letters indicate that there are no further sub-level softkey menus for that softkey.

Generally, a softkey that is underlined or displayed in inverse video indicates that the function is enabled. When an active function is enabled, it is always displayed in inverse video.

## Using the Front Panel to Enter Data

Data values are required for some softkey functions. The entries may be made using the numeric keypad, the **▲** and **▼** keys, and the front-panel knob. If applicable, the use of each method is described under each softkey description in the “Softkey Descriptions” section.

### Note

Unless otherwise noted, the rate of change of the front-panel knob is determined both by the measurement range and the speed at which the knob is turned.

Two other display front-panel keys that may be useful are **I-P** (instrument preset) and **←** (backspace). The **I-P** key initiates all the preset conditions of the lightwave section to the current display mode. That is, if **I-P** is pressed while in the RF bypass display mode, the instrument is preset to that display mode.

The **←** key brings you back through the menu structure in the reverse sequence of the softkeys that were pressed. Up to the last ten key presses are saved.

## Front-Panel and Rear-Panel Features

Figure 3-2 illustrates front- and rear-panel features of either an HP 70810B or an HP 70810B Option 850. Specifications for the lightwave section input and output connectors are provided in Chapter 5.

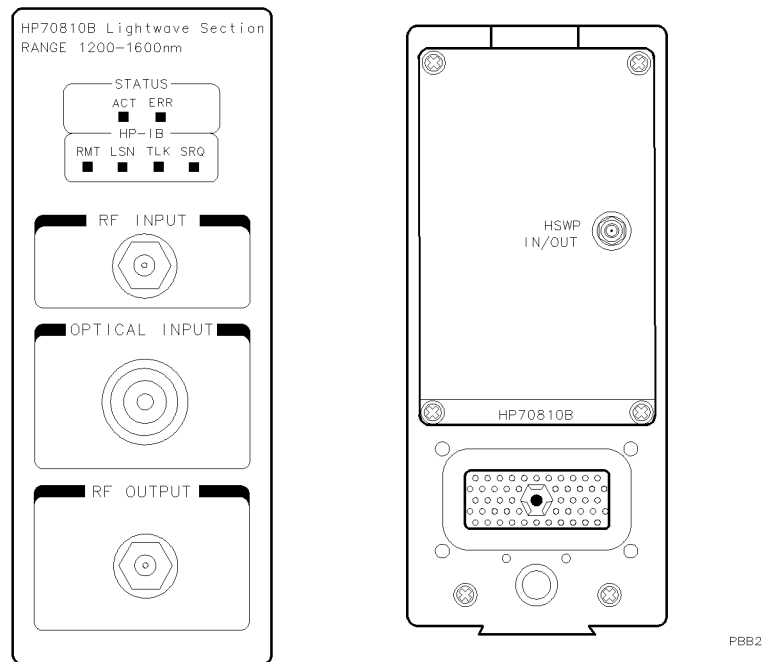

**Figure 3-2. HP 70810B Front Panel and Rear Panel**

### Front-Panel LEDs

Each front-panel LED indicates a condition or activity of the lightwave section. The LEDs flash on and off when the lightwave section is executing its self-test.

If the ERR (error) LED lights at any time other than during self-test, there is a problem with the lightwave section. Chapter 9 provides ERR LED troubleshooting suggestions.

If set by software, the SRQ (service request) LED can indicate certain conditions or occurrences (for example, an error condition or the completion of an operation). Self-test verifies that the LED will light.

The ACT (active), RMT (remote), LSN (listen), and SRQ (service request) LEDs indicate normal HP 70810B activities, not error conditions.

## Connectors and Latches

<b>RF INPUT</b>	The RF INPUT SMA connector presents a 50 $\Omega$ nominal input impedance.
<b>OPTICAL INPUT</b>	The OPTICAL INPUT connector can be one of several types listed as options under “Options and Accessories” in Chapter 10.
<b>RF OUTPUT</b>	The RF OUTPUT SMA connector provides a 50 $\Omega$ nominal output impedance.
<b>Module latch</b>	<p>The module latch secures the lightwave section in a mainframe. An 8 mm hex-ball driver (shipped with the mainframe) fits the lightwave section hex-nut latch.</p> <p>Refer to Chapter 1 for lightwave section installation and removal instructions.</p>
<b>HSWP IN/OUT</b>	When the lightwave section is configured in a lightwave signal analyzer system the HSWP signal synchronizes system operation with the system master. The high-sweep signal is high while the local oscillator is swept through a selected frequency span.
<b>Mainframe/module interconnect</b>	The 50-pin connector accesses the HP-IB and HP-MSIB communication buses and connects the lightwave section to the mainframe 40 kHz power supply.

---

## Cleaning Connections for Accurate Measurements

Accurate measurements require clean connections. Use the following guidelines to achieve the best possible performance when making measurements on a fiber-optic system:

- Keep connectors covered when not in use.
- Use dry connections whenever possible.
- Use the cleaning methods described in this section.
- Use care in handling all fiber-optic connectors.
- If an extremely good match is a concern, characterize the connector interfaces using both dry and wet connections. The results will show you the level of return loss performance you can expect from the connectors, dry and wet.
- When physical contact is not made at the fiber interface, use a reliable or recommended index-matching compound to achieve the best possible return loss, the lowest reflection, and the lowest insertion loss.

Because of the small size of cores used in fiber optic cables, care must be used to ensure good connections. Poor connections result from core misalignment, air gaps, damaged fiber ends, contamination, and improper use and removal of index-matching compounds.

### Note

---

#### Index-Matching Compounds

HP strongly recommends that index-matching compounds not be applied to the lightwave section's OPTICAL INPUT connector. If these compounds are required, clean thoroughly after every connection. If possible, attach an HMS-10/HP adapter cable to the instrument with a dry connection and make wet connections at the free end of the cable.

---

Use dry connections (without index-matching compounds). Dry connectors are easier to clean and to keep clean. Dry connections can be used with physically contacting connectors such as HMS-10/HP, Diamond®, ST, DIN, and PC connectors. If a dry connection has 40 dB return loss or better, making a wet connection will probably not improve performance.

### To clean a dry connector

1. Apply isopropyl alcohol to a clean lint-free swab or lens paper.  
Cotton swabs can be used as long as no cotton fibers remain on the fiber end after cleaning.
2. Clean the fiber end with the swab or lens paper. Move the swab or lens paper back and forth across the fiber end several times.  
Some amount of wiping or mild scrubbing of the fiber end can help remove particles when application of alcohol alone will not

remove them. This technique can remove or displace particles smaller than one micron.

3. Allow the connector to dry for about a minute. Or, use compressed air to dry it immediately.

Using compressed air lessens the chance of deposits remaining on the fiber end. Do not shake or tip the compressed air can, because this releases particles in the can into the air. Direct the compressed air horizontally across the fiber end.

4. As soon as the connector is dry, connect or cover it for later use.

### To clean a wet connector

Use of an index-matching compound cannot fix a damaged connector. Do not use gels in physically contacting connectors.

1. Use a clean lens paper to wipe any compound from the fiber end.
2. Use a clean lens paper to clean the ferrules and other mating surfaces of the connector.
3. Use isopropyl alcohol, clean lint-free swabs, and clean compressed air to clean the ferrule and other mating connector surfaces.

Contact the manufacturer of the index-matching compound for the recommended solvents and cleaning procedures.

### Warning

---

**Many solvents are toxic. Read the directions for the solvent before using the solvent or when disposing of it. Some solvents can leave residues on connectors or damage components.**

---

4. Clean the fiber end with alcohol and a lint-free swab. Move the swab across the fiber end.
5. Allow the connector to dry for about a minute or use compressed air to dry it immediately.

Using compressed air lessens the chance of deposits remaining on the fiber end. Do not shake or tip the compressed air can, because this releases particles in the can into the air. Direct the compressed air horizontally across the fiber end.

6. As soon as the connector is dry, connect or cover it for later use.

### To apply index-matching compound

1. Apply index-matching compound to the fiber ends using a clean wooden toothpick, the wooden end of a swab, or a syringe. Use as little index-matching compound as possible.

### Note

---

Do not apply compound to the connector's sleeve.

---

2. Immediately make the cable connection.



## Programming

---

This chapter describes how to operate a lightwave section by remote computer control.

---

### What You'll Find in This Chapter

Getting Set Up for Remote Operation .....	page 4-2
Communicating with the Lightwave Section .....	page 4-3
Transferring Data to the Computer .....	page 4-6
Monitoring System Operation .....	page 4-8

---

## Getting Set Up for Remote Operation

To connect your equipment for remote operation of the lightwave section:

1. Connect the computer, the mainframe containing the lightwave section, and other peripherals with HP-IB cables.
2. After the HP-IB cables are installed, reset all instruments connected to the bus. If you are not sure how to reset a device, switch its line power off, then on, to reset it.
3. Check the HP-IB address of the lightwave section on the address map. The lightwave section must be configured (in row 0) so that it is configured for stand-alone operation.

To view the address map, press the **DISPLAY** key on the display front-panel, then press the **Address Map** softkey. Turn the knob on the front panel of the display until the lightwave section appears in the address map.

---

### Note

The lightwave section must be located in row 0 for HP-IB access and error-reporting capabilities. The default column address is column 20. The lightwave section column address must also have a higher value than the column address of the display.

---

4. To observe the lightwave section operation on the display, press the **NEXT INSTR** softkey.

## Communicating with the Lightwave Section

This section develops some fundamental techniques for controlling the lightwave section and obtaining reliable measurement results. The lightwave section is remotely controlled with commands that correspond in general to front-panel softkey functions.

It is important to understand how messages are communicated to the lightwave section; therefore, enter and output statements and command syntax discussed in this chapter should be understood before proceeding. HP BASIC is used for all examples in this manual.

### Executing Remote Commands

The computer communicates with the lightwave section on the Hewlett-Packard Interface Bus (HP-IB), using HP BASIC OUTPUT and ENTER statements.

An OUTPUT statement tells the computer to send a message to the lightwave section. For example, executing the statement below sets the optical attenuator to 3 dB:

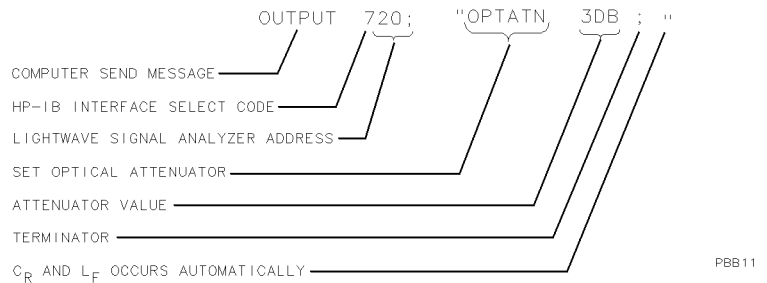

An ENTER statement used in conjunction with a lightwave section query returns information to the computer. To return the optical attenuator value to the computer, first form a query by adding a question mark (?) to the command:

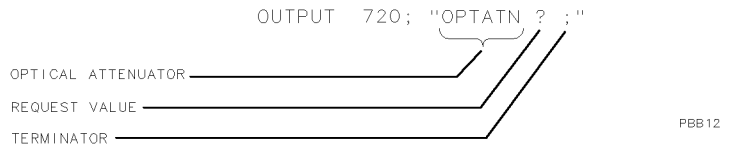

Next, the ENTER statement is used to assign the returned value to a variable in the computer:

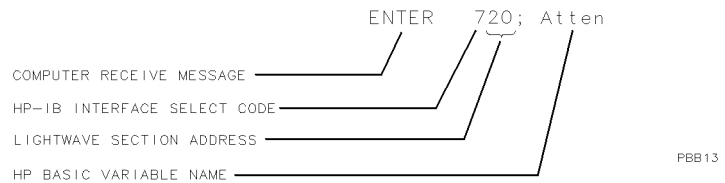

The value of the optical attenuator above is placed in the variable named “Atten”. The variable may be printed, stored, or used for other computer functions.

### Syntax Requirements

All of the program examples in this manual show recommended command syntax. All lightwave section commands must be constructed according to specific syntactical rules which are outlined in Chapter 8. That chapter lists all of the remote lightwave section commands in alphabetical order.

Refer to Table 8-2 in Chapter 8 for a complete alphabetical listing of all valid lightwave section remote commands.

### Local and Remote Control

Whenever the lightwave section is remotely addressed, the display front-panel softkeys are disabled and blanked. Pressing the **LOCAL** key or executing the HP BASIC statement LOCAL reactivates operation of the softkeys.

The front-panel indicators on the HP 70810B Lightwave Section light under the following conditions when the HP-IB interface is used:

- When the lightwave section is addressed, the RMT indicator lights.
- When the lightwave section receives information, the LSN indicator lights.
- When the lightwave section sends information, the TLK indicator lights.
- When a measurement event (for example, end of the sweep) has occurred and the lightwave section is requesting computer attention, the SRQ indicator lights (provided that the service-request mask is set to allow SRQ on end-of-sweep).

## Initial Program Considerations

Programs should begin with a series of HP BASIC statements and lightwave section commands that form a good starting point for lightwave measurements. The following example shows how to initialize the lightwave section.

```
10  ASSIGN @Lws to 720
20  CLEAR @Lws
30  OUTPUT @Lws;"LTWAVE ON;IP;"
```

The ASSIGN statement creates an I/O path name and assigns that name to an I/O device. In the example above, the I/O path name is @Lws. It is assigned to the device at interface select code 7 (the HP-IB interface), and at HP-IB address 20.

---

### Note

All program examples in this manual assume that the lightwave section is addressed at HP-IB address 20.

---

Using the ASSIGN statement in a program makes it easier to change the address of the lightwave section. In applications where speed is important, using ASSIGN can also improve program performance. Many of the examples in this chapter, and in the language reference, assume that the @Lws I/O path name is already assigned.

CLEAR is an HP BASIC statement that clears the input buffer, the output buffer, and the command parser of the specified instrument, so that it is ready for operation. This command may be used to clear devices on the bus singly or in unison. It is often desirable to clear only one instrument so that other instruments on the bus are not affected.

- To clear only the lightwave section, CLEAR @Lws should be used.
- To clear all devices at select code 7, CLEAR 7 must be used.

IP, the instrument preset command, presets all of the parameters of the lightwave section for the current mode of operation, and provides a good starting point for all measurement processes. Executing IP is actually the same as executing a number of commands that set the lightwave section to a known state. IP does not change the mode of operation (lightwave optical or RF bypass).

---

### Note

Turning the power on presets the instrument to the lightwave optical mode.

---

## Transferring Data to the Computer

The lightwave section returns information as decimal values in fundamental units shown in Table 4-1. The lightwave section also applies these units to data received from the computer which do not explicitly specify units.

**Table 4-1. Units for Returned Data**

Measured Data	Fundamental Unit
Amplitude	dBm, watt
Power	dBm, watt
Ratio	dB
Responsivity	volt/watt

As indicated in Table 4-1, power and amplitude information may be returned in several different units. The AUNITS (amplitude units) command is used to select the desired unit. The AUNITS command can either specify a single unit to be used for all power and amplitude information, or it can be set to automatically select the units, based on certain measurement settings.

Refer to the description of the AUNITS command in Chapter 8 of this manual for more information.

## Requesting and Receiving Data

Data transfer varies in simplicity, but in all cases is initiated with a lightwave section query. An HP BASIC ENTER statement in conjunction with a lightwave section query returns information to the computer.

Form a query by adding a question mark (?) at the end of an lightwave section command. The syntax charts in Chapter 8 show which commands can be used in queries.

In the following example, the optical attenuator value is returned to the computer:

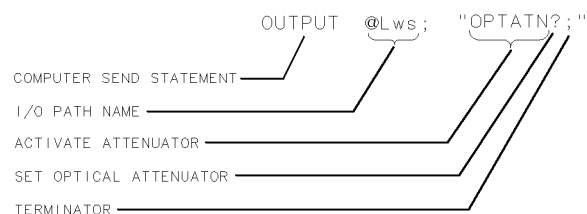

PBB 14

Use the ENTER statement to assign the returned value to a variable in the computer:

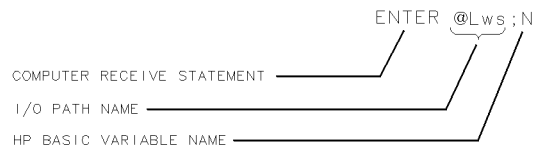

PBB15

---

## Monitoring System Operation

The programming techniques discussed so far describe communication between the lightwave section and the computer, where the sequence of all data transfer is controlled by a computer program. This section describes how the lightwave section can interrupt computer operation when the lightwave section has attained a particular state.

The interrupting process is called a service request. Service requests have many applications. They facilitate economical use of computer-processing time when the lightwave section is part of a large measurement system. For example, after the computer initiates a lightwave section measurement, the computer can make calculations or control other devices via HP-IB while the lightwave section is measuring. When the lightwave section is through, it signals the computer with a service request. The computer's service-request subprogram then determines what the computer will do next. Service requests can also be used to report lightwave section errors.

### Interrupt Process

The interrupt process begins when the lightwave section "requests" attention by setting the HP-IB service-request line (SRQ) true. The computer must be programmed to respond to this event. Typically, the computer is programmed to interrupt normal program execution and call a user-specified subroutine when the service request occurs. This subroutine must determine which instrument(s) on HP-IB caused the service request. Then, it may be necessary to call another subroutine which determines why a particular instrument requested service (since there may be more than one possible cause). Finally, a subroutine(s) will be called to respond to the indicated event(s). Note that more than one instrument may request service simultaneously, and each instrument may have more than one event to report. These steps are summarized below.

1. Computer monitors HP-IB service request line (SRQ).
2. Lightwave section requests service by setting the SRQ line true.
3. Computer branches to routine that determines the instrument(s) that caused the SRQ.
4. Computer branches to routine that determines why a particular instrument is requesting service.
5. Computer branches to routine to process a specific event in a particular instrument.

Some of the routines above may be omitted, if only one instrument has been instructed to use the SRQ line, or if a particular instrument has been instructed to use the SRQ line for only one event.

Several system-level statements are required to make the computer responsive to service requests. The HP BASIC statement, `ENABLE INTR` (enable interrupt), tells the computer to monitor the service-request line. The on-interrupt statement, `ON INTR`, specifies where the computer program will branch when a service request occurs. If more than one instrument could cause the service request, or if an instrument can cause a service request for more than one



reason, the serial-poll statement, SPOLL, is used. The serial-poll statement is always required to clear the service request being generated by the instrument.

### Lightwave Section Status Byte

The lightwave-section status byte indicates the status or occurrence of certain lightwave section functions. The status byte contains eight bits, numbered 0–7 with bit 0 being the least significant bit.

Bits 0, 1, 2, 3, 4, 5, and 7 represent specific conditions or events. These bits are referred to as condition bits and event bits. Condition bits reflect a condition in the lightwave section which may be present or absent at any given moment. Event bits reflect the occurrence of a transition or event within the lightwave section.

Bit 6 is set by the lightwave section to indicate whether or not it is requesting service.

When the lightwave section is instructed not to use the service request line on HP-IB, the status bits always reflect the current condition of the lightwave section. In this situation, the *event bits* in the status byte should not be used. Event bits are only true at the exact instant of a transition in the lightwave section and as such are not reliable when service requests are disabled.

When the lightwave section is instructed to generate service requests for one or more conditions or events, the status bits reflect the current condition of the lightwave section until a service request is generated. Then, the bits which are generating the service request are held true until the status byte is read out of the lightwave section (by the HP BASIC SPOLL system-level statement), by the STB? command, or until an HP-IB DEVICE CLEAR (HP BASIC CLEAR system-level statement) is received. These actions clear the status byte to once again reflect the current conditions and events within the lightwave section.

### The Service-Request Mask

The service-request mode is enabled and controlled by the request-service-condition command, RQS. It defines a service-request mask that specifies which of the status-byte bits may generate a service request.

In the following example, RQS specifies the ERROR-PRESENT and COMMAND-COMPLETE states (bits 5 and 4) for service requests:

```
OUTPUT @Lws;"RQS 48;"
```

*Selects bits 5 and 4 (32+16) to enable service request mode for ERROR-PRESENT and COMMAND-COMPLETE.*

```
OUTPUT @Lws;"RQS ";DVAL("00110000",2)
```

*Also selects bits 5 and 4 as above, but is somewhat easier to read.*

Once RQS is executed, the lightwave section requests service by setting the SRQ line true when the desired conditions or events occur.

**Table 4-2. Lightwave Section Status Byte**

Bit Number	Decimal Equivalent	Lightwave Section State	Description	Bit Type
7	128	OUT OF RANGE	Optical power is out of range for optical average power meter (too low or too high).	event
6	64	RQS	Set when service request is being generated.	—
5	32	ERROR-PRESENT	Set when error register contains an error.	condition
4	16	COMMAND-COMPLETE	Set at completion of command execution.	event
3	8	ZEROING	Optical power meter is executing its zeroing function.	condition
2	4	Not Used		
1	2	MESSAGE	Set when messages are displayed.	condition
0	1	Not Used		

### Service-Request Examples

The following program uses service requests to monitor measurement errors in the lightwave section. If an error occurs, computer operation is interrupted and a description of the error is printed.

EXAMPLE. This program enables an ERROR-PRESENT service request and returns an error description. It assumes that only one instrument is on the HP-IB.

```

10 COM /Insts/ @Lws
20 ASSIGN @Lws TO 720
30 CLEAR @Lws
40 OUTPUT @Lws;"IP;SNGLS;TS;"           Sends unrecognized commands to lightwave section.
50 ON INTR 7 CALL Lws_error
60 ENABLE INTR 7;2                       Enable computer interrupts for SRQ on interface
                                           select code (IFC) #7.
70 OUTPUT @Lws;"RQS 32;"

```

A measurement program would normally be inserted at this point in program.

```

80 END
90 SUB Lws_error
100 COM /Insts/ @Lws
110 DIM Errs$(1:6)[64]
120 INTEGER Status_byte
130 Status_byte=SPOLL(@Lws) This will clear the SRQ on HP-IB.
140 IF (BIT(Status_byte,5)) THEN Verify the lightwave section has errors to
                                report.
150 OUTPUT @Lws;"XERR?;" Ask lightwave section for extended error
                                list.
160 ENTER @Lws USING "%,K";Errs$(*) Read error list from lightwave section.
170 PRINT "Lightwave Section has reported
        the following error(s):"
180 PRINT USING "K,/";Errs$(*)

        You would normally take action at this point in program to
        determine which errors had occurred and fix the problem, or halt the
        measurement.

190 END IF
200 ENABLE INTR 7 Reenable SRQ interrupts.
210 SUBEND

```

## Monitoring System Operation without Using Service Requests

The STB command may be used to monitor the value of the status byte at any time. Executing STB? returns the decimal equivalent of the status byte to the computer. Executing STB is similar to conducting a serial poll of the status byte. When STB is executed, the status-byte is updated to reflect current lightwave section conditions.



## Specifications and Characteristics

---

This chapter contains the module specifications for the HP 70810B and HP 70810B Option 850 lightwave sections.

---

### What You'll Find in This Chapter

Configuration Modes .....	page 5-2
HP 70810B Module Specifications .....	page 5-3
HP 70810B Option 850 Module Specifications .....	page 5-6
Module Input and Output Characteristics .....	page 5-10

This information is organized into two categories: measurement-related specifications and characteristics. Tables in this chapter list specifications and characteristics together, in the same format. The user should understand the distinction between the terms:

- Specifications** describe warranted performance over the temperature range of 0 °C to +55 °C after one hour of continuous operation, unless otherwise noted.
- Unless otherwise noted, corrected limits are given when a specification range is improved with error-correction routines.
- Characteristics** provide useful, but non-warranted, functional and performance information. A *characteristic* appears in italics in the text to alert you that the parameter is not a warranted specification.

---

## Configuration Modes

The HP 70810B and HP 70810B Option 850 lightwave sections can be configured for operation in two modes: a lightwave module can operate either as part of an integrated measurement system (a lightwave signal analyzer) or operate independently in a stand-alone configuration.

A lightwave signal analyzer consists of an electrical spectrum analyzer and an HP 70810B lightwave section. The lightwave section is mated with and calibrated to the RF section of the spectrum analyzer. The HP 71400C lightwave signal analyzer includes the HP 71210C microwave spectrum analyzer. The HP 71401C lightwave signal analyzer includes the HP 71100C RF spectrum analyzer (with options 002 and 004).

When a HP 70810B lightwave section is configured as part of an HP 71400C or HP 71401C lightwave signal analyzer, refer to the specification reference chapter in the *HP 70000 Modular Spectrum Analyzer Installation and Verification Manual for HP 70900B Local-Oscillator Controlled Modules*. The module specifications and characteristics provided in this chapter apply directly to the stand-alone mode of operation. These module specifications must also be used when a lightwave section is configured as part of a lightwave signal analyzer system and has not been calibrated with the RF section of the spectrum analyzer.

### Note

---

HP 70810B Option 020 (system adjustment and calibration) is a special mating and calibration of the HP 70810B with the HP 70908A of an HP 71210C system, or with the HP 70904A of an HP 71100C system. It provides the system performance of an HP 71400C or HP 71401C system. This calibration is in addition to standard factory calibrations (module corrections) of the lightwave module, and is independent of any user calibration. Option 020 is denoted by labels affixed to the rear panel of both the HP 70810B and the electrical RF section (HP 70908A or HP 70904A). These labels indicate, by serial number, which modules were mated for calibration.

When the HP 70810B lightwave section is used with an RF section other than the one it was mated and calibrated with, the system will *not* provide the specified system frequency response. Module corrected specifications will then govern system performance.

---

---

## HP 70810B Module Specifications

This section lists HP 70810B lightwave section measurement-related specifications and characteristics. These specifications and characteristics apply to HP 70810B stand-alone operation or to systems which include an HP 70810B that has not been mated and calibrated with the RF section installed in the system.

All amplitude specifications are in optical dB unless noted otherwise.

**Table 5-1. HP 70810B Specifications and Characteristics (1 of 2)**

<b>Wavelength Range</b> <i>(characteristic)</i>	1200 nm to 1600 nm	
<b>Frequency Range</b> (demodulated signal)	100 kHz to 22 GHz	
<b>Average Power Accuracy</b>	<b>Factory-Calibrated</b>  (at 1300 and 1550 nm) ±0.65 dB ±5 nW ± connector variation*	<b>User-Calibrated</b>  (by external power meter) ±0.05 dB ±5 nW ± power meter accuracy†
<b>Responsivity</b> <i>(characteristic)</i>  <i>Nominal Value at 100 MHz</i>	<i>The responsivity is given for each instrument and is accurate to ±20%</i>  1200 V/watt	
<b>Noise Equivalent Power</b>	<b>Frequency</b>	<b>Noise Equivalent Power</b>
	100 kHz to 1 MHz	-55 dBm/√Hz
	1 MHz to 10 MHz	-61 dBm/√Hz
	10 MHz to 100 MHz	-66 dBm/√Hz
	100 MHz to 8 GHz	-70 dBm/√Hz
	8 GHz to 16 GHz	-68 dBm/√Hz
	16 GHz to 22 GHz	-64 dBm/√Hz
<b>Frequency Response</b> Relative to 100 MHz  <i>(characteristic)</i>	<b>Frequency</b>	<b>Corrected‡</b>
	100 kHz to 2.9 GHz	±2.0 dB§
	2.9 GHz to 22 GHz	±5.0 dB§
	<i>Uncorrected response rolloff is &lt;25 dB§ 100 kHz to 22 GHz</i>	
<b>Maximum Safe Optical Input Power</b>	<b>Average Power</b> +15 dBm	<b>Modulated Power</b> +15 dBm
<p>* Connector losses vary with such factors as connector type and quality, connector cleanliness, temperature, damage, and wear.</p> <p>† Applies to any wavelength when the average power readout is set to match the reading of an external calibrated optical power meter. Does not include VSWR losses.</p> <p>‡ Specifications achieved by applying module responsivity and/or frequency-response correction factors stored in the HP 70810B memory.</p> <p>§ Amplitude measurement is in electrical dB units.</p>		



**Table 5-1. HP 70810B Specifications and Characteristics (2 of 2)**

<b>Harmonic Distortion</b> Output $\leq -10$ dBm	43 dB* below fundamental	
<b>Optical Input Return Loss</b> with HMS-10/HP connector, 0 dB input attenuation	All internal reflectances $\leq -40$ dB and total return loss $\geq 35$ dB (specification).**	
<b>Electrical Input Flatness Corrected†</b> (characteristic)	<b>Frequency</b>	<b>Amplitude Error</b>
	100 kHz to 6 GHz	1.4 dB*
	6 GHz to 12 GHz	1.6 dB*
	12 GHz to 16 GHz	2.0 dB*
	16 GHz to 22 GHz	2.2 dB*
<b>Electrical Output Return Loss</b> (characteristic)	<b>Frequency</b>	<b>Return Loss</b>
	100 kHz to 6 GHz	12.0 dB*
	6 GHz to 12 GHz	10.5 dB*
	12 GHz to 16 GHz	8.5 dB*
	16 GHz to 22 GHz	7.5 dB*
<b>Bypass Mode Insertion Loss‡</b>	<b>Frequency</b>	<b>Insertion Loss</b>
	100 kHz to 6 GHz	2.5 dB*
	6 GHz to 12 GHz	3.7 dB*
	12 GHz to 16 GHz	4.9 dB*
	16 GHz to 22 GHz	5.2 dB*
<b>Input Connectors</b> (Option-dependent)	<b>Single-Mode Fiber Connectors</b> Diamond HMS-10/HP, FC/PC, ST, Biconic, DIN	
<p>* Amplitude measurement is in electrical dB units.</p> <p>** This is the specification for serial prefix 3237A and above. <i>Serial prefix 3242A and below: 27 dB with optical input attenuation <math>\geq 5</math> dB (characteristic)</i></p> <p>† When a lightwave section is installed in a measurement system, add the amplitude-error value to the related flatness specifications for the system. Adding a second lightwave section doubles the amount of amplitude-error that must be added to the system specifications.</p> <p>‡ When a lightwave section is installed in a measurement system, add the insertion-loss value to the related absolute-amplitude specifications for the system. Adding a second lightwave section doubles the amount of insertion loss that must be added to the system specifications.</p>		

---

## **HP 70810B Option 850 Module Specifications**

This section lists HP 70810B Option 850 lightwave section characteristics and measurement-related specifications. These specifications and characteristics apply to HP 70810B stand-alone operation or to systems which include an HP 70810B that has not been mated and calibrated with the RF section installed in the system.

All amplitude specifications are in optical dB unless noted otherwise.

**Table 5-2.**  
**HP 70810B Option 850 Specifications and Characteristics (1 of 2)**

<b>Wavelength Range</b> <i>(characteristic)</i>	750 nm to 870 nm	
<b>Frequency Range</b> (demodulated signal)	100 kHz to 22 GHz	
<b>Average Power Accuracy</b>	<b>Factory-Calibrated</b>	<b>User-Calibrated</b>
	(At 850 nm)	(By external power meter)
	±0.65 dB ±5 nW	±0.05 dB ±5 nW
	± connector variation*	± power meter accuracy <sup>†</sup>
<b>Responsivity</b> <i>(characteristic)</i>	<i>The responsivity is given for each instrument and is accurate to ±20%</i>	
<i>Nominal Value at 100 MHz</i>	500 V/watt	
<b>Noise Equivalent Power</b>	<b>Frequency</b>	<b>Noise Equivalent Power</b>
	100 kHz to 1 MHz	-51 dBm/√Hz
	1 MHz to 10 MHz	-57 dBm/√Hz
	10 MHz to 100 MHz	-62 dBm/√Hz
	100 MHz to 8 GHz	-66 dBm/√Hz
	8 GHz to 16 GHz	-64 dBm/√Hz
	16 GHz to 22 GHz	-60 dBm/√Hz
<b>Frequency Response</b> Relative to 100 MHz	<b>Frequency</b>	<b>Corrected<sup>‡</sup></b>
	100 kHz to 2.9 GHz	±2.0 dB <sup>§</sup>
	2.9 GHz to 22 GHz	±5.0 dB <sup>§</sup>
<i>(characteristic)</i>	<i>Uncorrected response rolloff is &lt;25 dB<sup>§</sup> 100 kHz to 22 GHz</i>	
<p>* Connector losses vary with such factors as connector type and quality, connector cleanliness, temperature, damage, and wear.</p> <p><sup>†</sup> Applies to any wavelength when the average power readout is set to match the reading of an external calibrated optical power meter. Does not include VSWR losses.</p> <p><sup>‡</sup> Specifications achieved by applying module responsivity and/or frequency-response correction factors stored in the HP 70810B memory.</p> <p><sup>§</sup> Amplitude measurement is in electrical dB units.</p>		

**Table 5-2.**  
**HP 70810B Option 850 Specifications and Characteristics (2 of 2)**

<b>Maximum Safe Optical Input Power</b>	<b>Average Power</b> +15 dBm	<b>Modulated Power</b> +15 dBm
<b>Harmonic Distortion</b> Output $\leq -10$ dBm	43 dB* below fundamental	
<b>Optical Input Return Loss</b> <i>(characteristic)</i> with HMS-10/HP connector	$>27$ dB with optical input attenuation $\geq 5$ dB	
<b>Electrical Input Flatness Corrected†</b> <i>(characteristic)</i>	<b>Frequency</b>	<b>Amplitude Error</b>
	100 kHz to 6 GHz	1.4 dB*
	6 GHz to 12 GHz	1.6 dB*
	12 GHz to 16 GHz	2.0 dB*
	16 GHz to 22 GHz	2.2 dB*
<b>Electrical Output Return Loss</b> <i>(characteristic)</i>	<b>Frequency</b>	<b>Return Loss</b>
	100 kHz to 6 GHz	12.0 dB*
	6 GHz to 12 GHz	10.5 dB*
	12 GHz to 16 GHz	8.5 dB*
	16 GHz to 22 GHz	7.5 dB*
<b>Bypass Mode Insertion Loss‡</b>	<b>Frequency</b>	<b>Insertion Loss</b>
	100 kHz to 6 GHz	2.5 dB*
	6 GHz to 12 GHz	3.7 dB*
	12 GHz to 16 GHz	4.9 dB*
	16 GHz to 22 GHz	5.2 dB*
<b>Input Connectors</b> (Option-dependent)	<b>Single-Mode Fiber Connectors</b> Diamond HMS-10/HP, FC/PC, ST, Biconic, DIN	
<p>* Amplitude measurement is in electrical dB units.</p> <p>† When a lightwave section is installed in a measurement system, add the amplitude-error value to the related flatness specifications for the system. Adding a second lightwave section doubles the amount of amplitude-error that must be added to the system specifications.</p> <p>‡ When a lightwave section is installed in a measurement system, add the insertion-loss value to the related absolute-amplitude specifications for the system. Adding a second lightwave section doubles the amount of insertion loss that must be added to the system specifications.</p>		

**Table 5-3.  
 HP 70810B and HP 70810B Option 850  
 General Specifications and Characteristics**

<b>Temperature</b>	<b>Operation</b> 0°C to +55°C	<b>Storage</b> −40°C to +75°C
<b>HP 70810B Weight</b> <i>(characteristic)</i>	<i>1.75 kg (3.9 lb)</i>	
<b>HP 70810B Dimensions</b>	Standard 1/8-width module	

---

## Module Input and Output Characteristics

This section covers the input and output specifications and characteristics of the HP 70810B and HP 70810B Option 850 lightwave section modules. The data in this section is a characteristic unless identified as a specification in Table 5-1 or Table 5-2.

<b>Lightwave Input</b>	HP 70810B wavelength range .....	1200 nm to 1600 nm
	HP 70810B Option 850 wavelength range .....	750 nm to 870 nm
	Frequency range (demodulated signal) .....	100 kHz to 22 GHz
	Maximum input average optical power .....	+ 15 dBm
	Input fiber size .....	9 micron core

<b>RF Input</b>	Frequency Range .....	0 Hz to 22 GHz
	VSWR	
	0 GHz to 6 GHz .....	<1.3
	6 GHz to 12 GHz .....	<1.5
	12 GHz to 22 GHz .....	<1.9

The actual input frequency range is limited by the frequency range of the RF section that is installed in the lightwave signal analyzer.

The actual safe input power is limited by the maximum safe input power of the RF section that is installed in the lightwave signal analyzer.

<b>RF Output</b>	Frequency Range .....	0 Hz to 22 GHz
	Insertion Loss .....	< 5.2 dB

<b>HSWP In/Out</b>	Line Type .....	TTL (open collector)
	Sweep condition .....	low = not ready to sweep
	Maximum Delay .....	200 $\mu$ s from HSWP high to sweep
	Maximum Current Draw .....	16 mA

## Menu Maps

---

This menu map graphically represents all top-level softkeys and their associated lower-level softkeys (the top-level softkeys are located along the left side of the display). Figure 6-1 illustrates the display menu organization for the lightwave section softkeys. A description of each softkey is listed in alphabetical order in Chapter 7.

---

### What You'll Find in This Chapter

Softkey Menu Map for Stand-Alone Operation ..... page 6-2

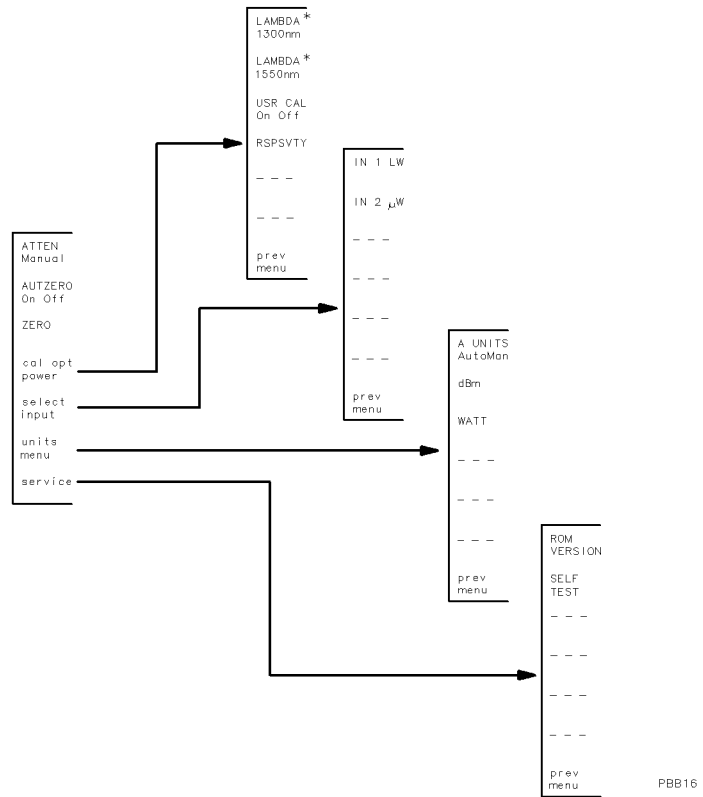

\* If the lightwave section is an HP 70810B Option 850, the softkey is not displayed. The **LAMBDA 1330nm** softkey is replaced by the **LAMBDA 850nm** softkey.

**Figure 6-1. Softkey Menu Map for Stand-Alone Operation**



## Dictionary Reference

---

This chapter contains descriptions of softkeys and front- and rear-panel features and connectors.

---

### What You'll Find in This Chapter

Alphabetical Listing of Softkeys, Connectors, and Latches . . .page 7-2

## Alphabetical Listing of Softkeys, Connectors, and Latches

**A UNITS**  
**AutoMan**

(absolute amplitude units) selects default amplitude units. The softkey also allows either dBm or watts units to be selected manually.

The function is preset for automatic mode and dBm units annotation. To set the softkey function to manual, press the softkey or select an alternate amplitude readout unit using either the **dBm** or **WATT** softkey.

**ATTEN**  
**Manual**

(manual attenuator) allows the optical input attenuation to be entered manually. The optical input attenuation range is from 0 to 30 dB in 1 dB steps in optical decibel units.

In RF bypass mode, the lightwave section RF INPUT is connected directly to its RF OUTPUT, bypassing the optical input attenuator.

**AUTZERO**  
**On Off**

(automatic zeroing) selects automatic zeroing of offsets in the internal power meter.

This function is preset to ON, which allows the zeroing to occur automatically at given time intervals according to the average power being measured and the attenuator setting that is selected. Refer to the table below for the power ranges and their corresponding time intervals.

<b>Range</b>	<b>Optical Power Level Attenuation</b>	<b>Time</b>
1	0 to -10 dBm	100 minutes
2	-10 to -20 dBm	100 minutes
3	-20 to -30 dBm	100 minutes
4	-30 to -40 dBm	10 minutes
5	-40 to -50 dBm	1 minute

During zeroing, the light input is blocked by the internal optical attenuator wheel.

When **Off** is selected, zeroing occurs only when the **ZERO** softkey is pressed.

SEE: **ZERO** softkey description for more information.

cal opt  
power

(calibrate optical power) enables access to the calibrated wavelengths and the user-specified power level functions listed below.

Softkeys available with a standard HP 70810B:

LAMBDA	
1300 nm	Lambda (wavelength) 1300 nm
LAMBDA	
1550 nm	Lambda (wavelength) 1550 nm
USR CAL	
On Off	User power calibration

Softkeys available with an HP 70810B Option 850:

LAMBDA	
850 nm	Lambda (wavelength) 850 nm
USR CAL	
On Off	User power calibration

These softkey functions are necessary to calibrate the lightwave section when using the OPTICAL INPUT. Refer to the related softkey function descriptions for more information.

dBm

is used to select dBm units for amplitude readouts.

**HSWP IN/OUT**

When the lightwave section is configured in a lightwave signal analyzer system the HSWP signal synchronizes system operation with the system master. The high-sweep signal is high while the local oscillator is swept through a selected frequency span.

IN 1 LW

(lightwave input port) selects the OPTICAL INPUT on the front panel of the lightwave section and activates lightwave mode for the module.

When configured for stand-alone operation the lightwave section functions as an optical-to-electrical signal converter and an optical average power meter. A power bar display and numeric readout for the power meter are displayed on screen.

IN 2  $\mu$ W

(microwave input port) selects the RF INPUT on the front panel of the lightwave section and activates RF bypass mode for the module. In RF bypass mode a signal is passed directly from the RF INPUT to the RF OUTPUT of the lightwave section.

**LAMBDA 850 nm** (lambda wavelength 850 nm) selects 850 nm as the calibrated wavelength when using the OPTICAL INPUT. The appropriate wavelength depends on the lightwave signal source that is applied to the input. The selection of this function applies the appropriate correction terms for this wavelength automatically.

This softkey is available only with an HP 70810B Option 850 lightwave section.

**LAMBDA 1300 nm** (lambda wavelength 1300 nm) selects 1300 nm as the calibrated wavelength when using the OPTICAL INPUT. The appropriate wavelength depends on the lightwave signal source that is applied to the input. The selection of this function applies the appropriate correction terms for this wavelength automatically.

This softkey is available only with a standard HP 70810B lightwave section.

**LAMBDA 1550 nm** (lambda wavelength 1550 nm) selects 1550 nm as the calibrated wavelength when using the OPTICAL INPUT. The appropriate wavelength depends on the lightwave signal source that is applied to the input. The selection of this function applies the appropriate correction terms for this wavelength automatically.

This softkey is available only with a standard HP 70810B lightwave section.

#### **Mainframe/module interconnect**

The 50-pin connector accesses the HP-IB and HP-MSIB communication buses and connects the lightwave section to the mainframe 40 kHz power supply.

#### **Module latch**

The module latch secures the lightwave section in a mainframe. An 8 mm hex-ball driver (shipped with the mainframe) fits the lightwave section hex-nut latch.

Refer to Chapter 1 for lightwave section installation and removal instructions.

#### **OPTICAL INPUT**

The OPTICAL INPUT connector can be one of several types listed as options under “Instrument Options” in Chapter 10.

#### **RF INPUT**

The RF INPUT SMA connector presents a 50  $\Omega$  nominal input impedance.

#### **RF OUTPUT**

The RF OUTPUT SMA connector provides a 50  $\Omega$  nominal output impedance.

#### **ROM VERSION**

(ROM firmware version) displays the firmware version of the lightwave section in the general information annotation block of the display.

The firmware version is coded by date: YEAR-MONTH-DAY (yy-mm-dd).

**RSPSVTY** (responsivity) allows the lightwave section responsivity to be displayed. Responsivity is a measure of the lightwave section's voltage output per unit of optical power input (units = volts/watt) at the RF output of the lightwave section.

**select input** accesses the **IN 1 LW** and **IN 2  $\mu$ W** softkeys.

**SELF TEST** performs a functional check of the power meter and optical attenuator. If the self test fails, the appropriate error messages are displayed.

If the self test fails, suspect a hardware failure. Contact your nearest Hewlett-Packard sales and service office.

**service** (service menu) accesses the **ROM VERSION** and **SELF TEST** softkeys.

**units menu** accesses the amplitude readout selections that are available for stand-alone operation. The available amplitude readout selections are:

<b>A UNITS</b>	
<b>AutoMan</b>	Absolute amplitude units
<b>dBm</b>	dBm units
<b>WATT</b>	Watt units

**USR CAL On Off** (user calibration, on or off) allows the displayed power level to be adjusted, using a known input power level, specified by the user. The function offsets the power meter readout.

This function is typically used either to correct connector insertion-loss errors or to operate at a user-defined wavelength that is not one of the factory-calibrated wavelengths.

When the function is active, an absolute power level offset is added to all power meter readouts. The offset also affects any power meter information that is returned to a computer during remote-control operations. Offsets are limited to a range of approximately  $\pm 2$  dB.

The user calibration function is preset off.

To enter an offset, enter the known amplitude value of the lightwave input signal, using the numeric keypad. Terminate the entry with the **dBm**,  **$\mu$ W**, or **mW** softkey. The input value can also be modified using the **▲** and **▼** keys or the front-panel knob.

To eliminate an offset, turn the **USR CAL On Off** function off or press **(INSTR PRESET)**.

**WATT**

(watt units) selects watt units for the amplitude readout.

**ZERO**

(zero offset compensation) zeros the power meter.

Pressing the **ZERO** softkey immediately executes a zeroing of the offsets in the internal average power meter. The offsets are primarily due to photodiode dark current.

When the zeroing function is activated, a **ZEROING ...** message is displayed momentarily in place of the numeric readout for the power meter. During zeroing, the light input is blocked by the internal optical attenuator wheel.

**AUTZERO**

SEE: **On Off** softkey description for additional information.

## Programming Commands

---

This chapter describes the syntax, parameters, and functions of the commands used to operate an HP 70810B or HP 70810B Option 850 lightwave section as a stand-alone lightwave receiver.

---

### What You'll Find in This Chapter

Syntax Conventions .....	page 8-2
Common Command Parameters .....	page 8-5
Commands by Functional Group .....	page 8-7
Alphabetical Command Summary .....	page 8-8
Commands Listed in Alphabetical Order .....	page 8-10

# Syntax Conventions

- Pictorial Notation**
- All items enclosed by an oval are literals and must be entered exactly as shown.
  - Items enclosed by a rectangular box indicate parameters used in the command sequence. A description of each parameter is given in the respective command description.
  - Command sequence items are connected by lines. Each line can be followed in only one direction, as indicated by an arrow at the end of each line.
  - Any combination of command sequence items that can be generated by following the lines in the proper direction is syntactically correct.
  - A command sequence item is optional if there is a valid path around it.

<b>Text Notation</b>	CAPITAL LETTERS	Capital letters represent literals and are to be entered exactly as shown.
	<b>Boldface</b>	Boldface letters represent literals and must be entered exactly as shown.
	TYPE STYLE	Letters using this type style indicate key words (commands and command parameters) used to compose command sequences. Items shown in this type style must be entered exactly as shown.
	TYPE STYLE	Letters using this type style indicate messages that appear on the display.

## Command Sequence

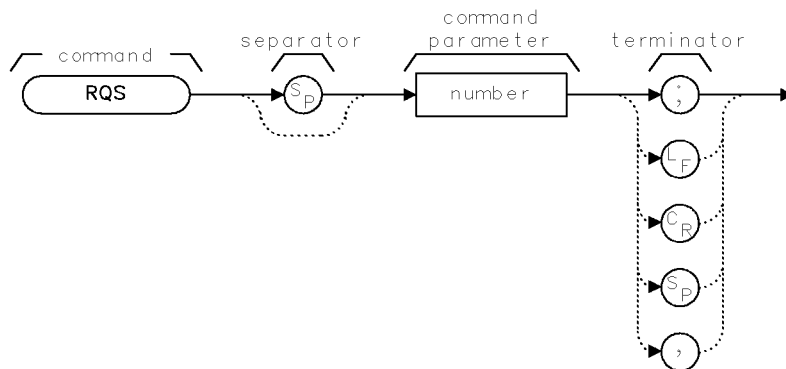

XGENF 1

A typical command sequence is represented above. The order of each item is specified in the syntax diagram for each respective command.



The “Syntax Summary” section provides a description of the syntax elements shown in the sequence above.

<b>Syntax Summary</b>	<b>command</b>	Any valid command which is a literal and must be entered exactly as shown.
	<b>separator</b>	Separators are required to separate command sequences and command sequence items. The separators allowed for the HP 70810B lightwave section are as follows:  S <sub>P</sub> (space) , (comma)
	<b>command parameter</b>	Any secondary key word recognized by the command.
	<b>terminator</b>	A terminator is required to end all command sequences. The terminators allowed for a lightwave section are as follows:  ; (semicolon) L <sub>F</sub> (line feed) C <sub>R</sub> (carriage return) S <sub>P</sub> (space) , (comma)

## Query Responses

Commands that set a function to a numeric value can be queried to determine the current setting of that function. For example, the OPTATN command sets the optical attenuator to a numeric value in dB. The format of the query response for the OPTATN command is shown below.

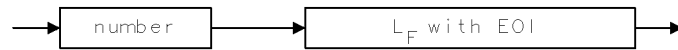

QGENF 1

**Figure 8-1. Numeric Value Query Response**

Other commands which control the binary state of a function can also be queried to determine its state. Examples are commands which accept ON and OFF parameters such as the CALCOR command, and other commands which accept AUTO and MAN parameters such as the ZERO command.

The query response in these cases, as shown below, is either zero (indicating that the queried state is off or inactive) or one (indicating that the queried state is on or active). As an example, CALCOR? will return a zero if the optical power error-correction factors are disabled, and a one if correction factors are enabled. The query ZERO MAN? returns a one if the power-meter zeroing function is set for manual operation, and a zero if it is set for automatic zeroing.

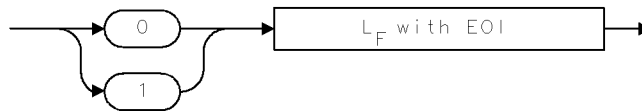

QGENF 2

**Figure 8-2. Binary State Query Response**

## Common Command Parameters

<b>data byte</b>	8-bit byte containing numeric or character data.
<b>data byte &amp; EOI</b>	8-bit byte containing numeric or character data sent with end-or-identify (EOI).
<b>delimiter</b>	! " \$ % & ' / : = \ @ & ^ '   ~ A character, chosen from the above list, marks the beginning and end of a string of characters. For simplified use, choose delimiters that are <i>not</i> the same as any character within the string they delimit. Otherwise, every occurrence of the delimiter character inside the string being delimited must be replaced with a <i>pair</i> of delimiters when forming the delimited string.
<b>digit</b>	0 1 2 3 4 5 6 7 8 9
<b>LF with EOI</b>	Line feed (LF) with end-or-identify (EOI). ASCII code 10 (line feed) is sent with EOI control line.
<b>number</b>	Expressed in integer, decimal, or exponential (E) form. <b>Range:</b> $-10^{+100}$ through $+10^{+100}$ The smallest positive fractional number which may be represented is $+10^{-100}$ . This is the range of numbers that may be used in commands. This range is further restricted when numbers are attached to specific types of units: <ul style="list-style-type: none"><li>■ frequency values are limited to <math>\pm 1000</math> GHz.</li><li>■ amplitude values are limited to <math>\pm 300</math> dBm or <math>\pm 300</math> dB.</li><li>■ power values are limited to <math>\pm 300</math> dBm or <math>\pm 300</math> dB.</li></ul> The above ranges may be further limited by hardware. These limitations are identified under the individual command descriptions. <b>Precision:</b> approximately 15 decimal digits, unless otherwise limited by hardware. <b>Length:</b> the complete number must be less than 25 characters.

### Syntax Diagram:

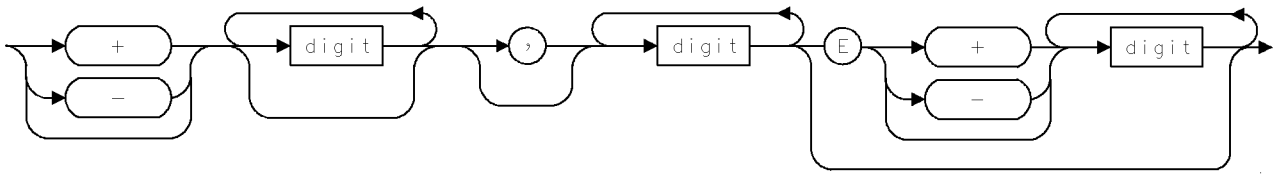

GNUMBER

### units

The following power units are available:

- dBm
- watts

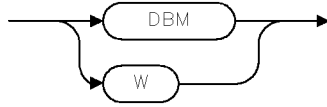

POWER

**Table 8-1. Commands by Functional Group**

<b>Amplitude Commands</b>		
AUNITS	Amplitude units	Specifies units for amplitude readouts.
OPTATN	Optical attenuator	Controls the optical input attenuator.
OPTPWR	Optical power	Returns a measured value of optical power.
RSPSVTY	Responsivity	Returns the overall responsivity of the lightwave section.
<b>Calibration Commands</b>		
CAL	Calibrate	Executes power-meter correction.
CALCOR	Calibration correction	Controls application of power-meter correction factors.
OPTCOR	Optical frequency response corrections	Returns amplitude corrections for the lightwave section.
ZERO	Optical power meter zeroing	Zeroes optical power meter.
<b>Configuration Commands</b>		
LTWAVE	Lightwave mode	Enables lightwave signal analysis.
<b>Information Commands</b>		
ERR	Error	Lists errors by number only.
ID	Identification	Returns lightwave section model number.
MSG	Message	Returns contents of message area.
REV	Output revision number	Returns firmware revision number of lightwave section.
SER	Serial number	Stores and returns the lightwave section serial number.
TEST	Self test	Initiates self-test routine.
USERMSG	User message	Writes a message in the message area.
XERR	Extended error query	Lists errors for the lightwave section.
<b>Input/Output Commands</b>		
DONE	Done	Returns a "1" when all commands previously entered are parsed.
HD	Hold	Blanks the readout and disables the keys until another active function is executed.
RQS	Request Service Conditions	Defines conditions that cause service requests.
SRQ	Service Request	Sets bit(s) in the status byte to simulate a service request.
STB	Status Byte	Returns value of status byte.
<b>Instrument State Commands</b>		
IP	Instrument Preset	Sets all functions to their preset state.

**Table 8-2. Alphabetical Command Summary**

<b>Command</b>	<b>Command Description</b>	<b>Corresponding Key</b>
AUNITS	Selects units for amplitude annotation and data.	A UNITS AutoMan
CAL	Performs the lightwave section average-power calibration routine.	cal opt power
CALCOR	Controls application of the average-power correction factors.	USR CAL On Off
DONE	Returns a "1" when all commands previously entered are parsed.	—
ERR	Lists errors by number only.	—
HD	Blanks readout and disables keys	(HOLD)
ID	Identifies lightwave section by model number.	—
IP	Performs an lightwave section preset.	—
LTWAVE	Enables lightwave measurement path.	select input
MSG	Returns contents of message area.	—
OPTATN	Controls the optical input attenuator.	ATTEN Manual
OPTCOR	Returns optical frequency response error corrections.	—
OPTPWR	Returns a measured value of optical power.	—
REV	Returns lightwave section firmware version number.	ROM VERSION

**Table 8-2. Alphabetical Command Summary (continued)**

<b>Command</b>	<b>Command Description</b>	<b>Corresponding Key</b>
RQS	Define conditions that cause a request service condition.	—
RSPSVTY	Returns responsivity value for the HP 70810B.	RSPSVTY
SER	Stores and returns the lightwave section serial number.	—
SRQ	Sets status bits to simulate a service request.	—
STB	Return value of status byte register.	—
TEST	Initiates self-test routine.	—
USERMSG	Writes a message in the message area.	—
XERR	Lists errors for the lightwave section.	—
ZERO	Zero optical power meter.	AUTZERO On Off ZERO

# AUNITS

**Amplitude Units** Specifies units for amplitude readouts.

## Syntax

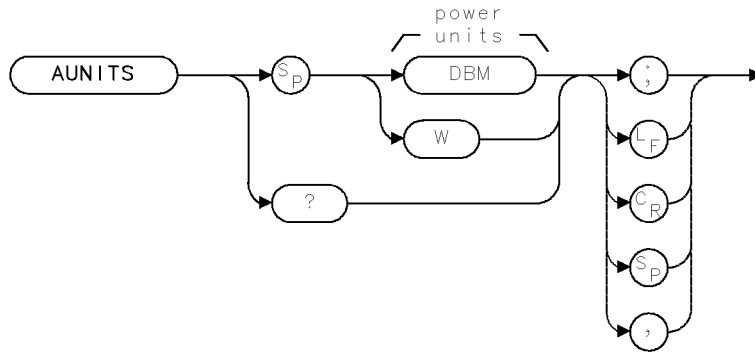

XAUNIT

Preset state: ..... dBm

## Example

```

OUTPUT @Lws;"LTWAVE ON;"      Select lightwave mode.
OUTPUT @Lws;"AUNITS W;"      Display optical signals in watt
                               units.
  
```

## Description

The AUNITS command changes the units of the amplitude readouts displayed on the display screen or returned to the controller. The AUNITS command also determines the amplitude units assumed for lightwave section commands when no units are explicitly given (the default-units path).

## Query Response

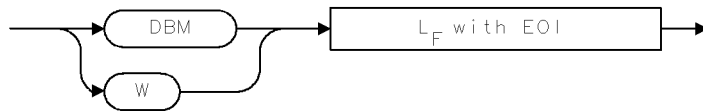

QAUNIT



**CAL**

**Calibrate**

Executes the optical power correction routine.

**Syntax**

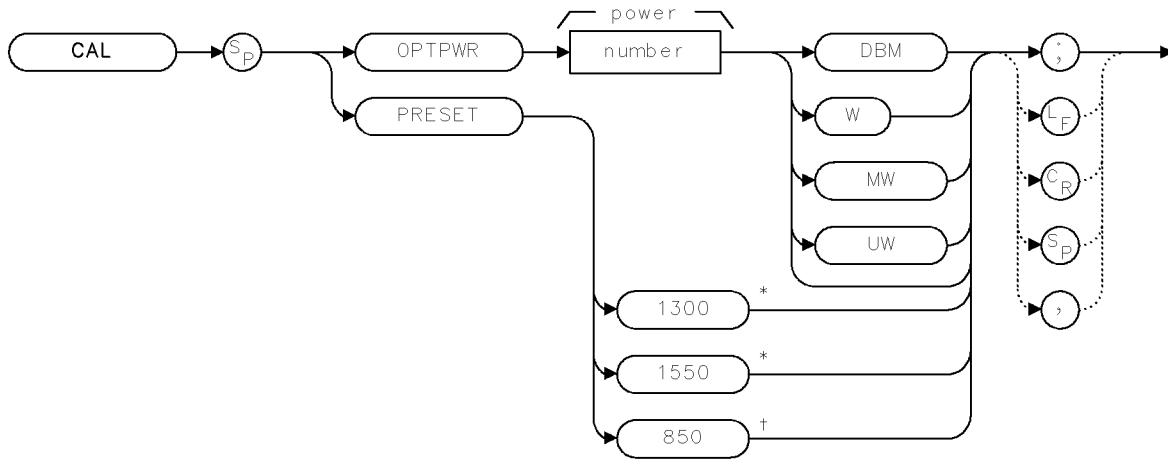

XCAL

\* Available only for use with a standard HP 70810B.

† Available only for use with an HP 70810B Option 850.

Related command: ..... CALCOR

**Example**

OUTPUT @Lws;"CAL PRESET 1550;" *Selects preset error corrections for a wavelength of 1550 nm.*

**Description**

The CAL command applies the appropriate amplitude correction that compensate for responsivity variations in the lightwave section circuitry.

The functions that can be executed individually are:

- CAL OPTPWR corrects the power meter, if possible, to display the power level requested by the user. Approximate adjustment range is  $\pm 2$  dB. (A lightwave signal calibration source is required when CAL OPTPWR is used.)
- CAL PRESET applies factory-determined corrections for one of the operating wavelengths, 1300 nm or 1550 nm for a standard HP 70810B, or 850 nm for an HP 70810B Option 850. The preset state for this function is 1300 nm, or 850 nm with an Option 850.

This command automatically turns off user-supplied optical power corrections that have been enabled with the CAL OPTPWR command.

Use the CALCOR command to enable or disable the optical power correction factor.

# CALCOR

**Calibration correction factor** Controls application of the optical power correction factor.

## Syntax

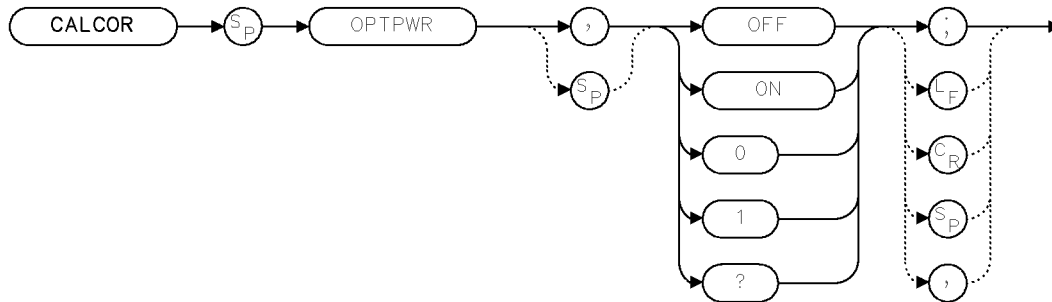

XCALCO

Preset state: ..... CALCOR OPTPWR, OFF

Related command: ..... CAL

**Example** Disable the optical power correction factor.

```

OUTPUT @Lws;"CALCOR OPTPWR,OFF;" Turn off optical power correction factor.

```

Query the status of the optical power correction factor.

```

OUTPUT @Lws;"CALCOR OPTPWR,?;" Request status of optical power correction factor.
ENTER @Lws;A Enter returned status value into a variable.

```

**Description** The CALCOR command enables and disables the user-supplied optical power correction factor used by the CAL command.

CALCOR OPTPWR, OFF disables the user-supplied optical power correction.

During normal operation, the correction factors for CALCOR OPTPWR are off. Set the command to on when you wish to use your own optical power calibration factors.

**DONE**

**Done**

Returns a "1" to the computer when all prior commands are complete.

**Syntax**

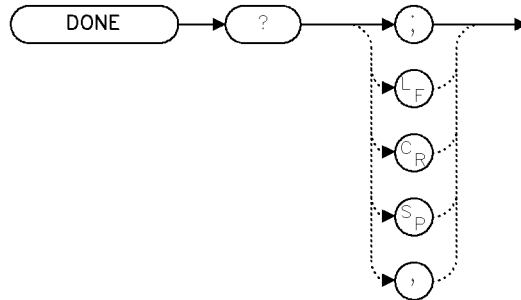

XDONE

**Example**

Use DONE to delay the execution of subsequent commands until all previous commands have been executed.

```
OUTPUT @Lws;"DONE?;"      Return a "1" when the previous com-
                           mands have been executed.
ENTER @Lws;A              Assign "1" to computer variable.
```

**Description**

The DONE command returns a "1" to the computer when all of the commands encountered before the DONE command have executed.

For example, when DONE? is executed, the user is assured the operation of the computer program is suspended until all previous commands have been executed.

**Query Response**

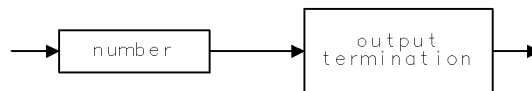

QGENNU

# ERR

## Error

Returns codes of reported errors.

### Syntax

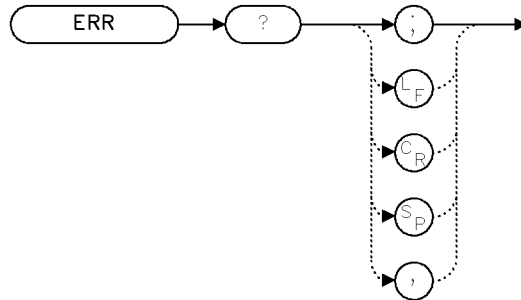

XERR

Interdependent command: ..... IP clears the error register.

### Example

Use the ERR command to report lightwave section errors to the computer.

```

CLEAR @Lws
OUTPUT @Lws;"IP;";
ALLOCATE Error_numbers$ [50]

OUTPUT @Lws;"SAVES 1;VIEW;";

OUTPUT @Lws;"ERR?;";

ENTER @Lws;Error_numbers$

```

*Initialize analyzer.*

*Create 50-element array in computer for the storage of any returned lightwave section errors.*

*Send two unrecognized commands to the lightwave section.*

*Return lightwave section error codes to the computer.*

*Store error codes in computer array.*

### Description

The ERR command returns numeric error codes, if any have occurred. Refer to Chapter 9 for a description of each returned error message.

Error codes are stored in the error register as they occur. ERR returns codes as long as they are in the register. If none are present, ERR returns "0" (zero). Instrument preset (IP) clears the error register.

### Query Response

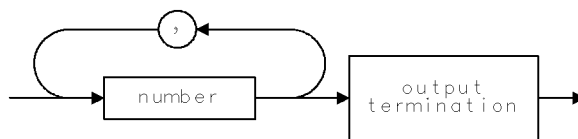

QERR

HD

**Hold**

Blanks the active function and disables the front-panel knob, step keys, and numeric keypad.

**Syntax**

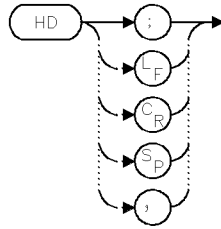

**Example**

Use the HD command to blank the active function readout.

```

CLEAR @Lws           Initialize analyzer.
OUTPUT @Lws;"IP;";
OUTPUT @Lws;"CF 1GHZ;";  Set center frequency. Notice that the active function area (left side of graticule) displays the center frequency value.

OUTPUT @Lws;"WAIT 4S;";  Wait 4 seconds.
OUTPUT @Lws;"HD;";      Blank active function readout.
    
```

**Description**

The HD command blanks the active function readout and disables the front-panel numeric keypad, step keys, and knob, until another active function is executed.

**Query Response**

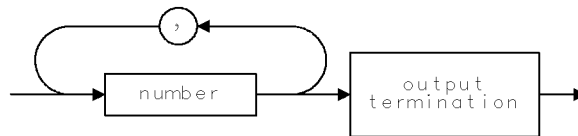

QERR

# ID

**Identification** Returns the lightwave section model number.

## Syntax

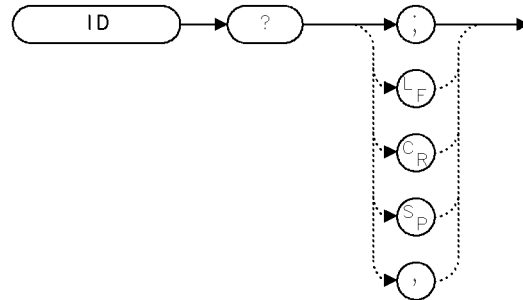

X10

**Example**      `OUTPUT @Lws;"ID?;"`      *Return lightwave section model number.*  
`ENTER @Lws;N$`      *Enter lightwave section model number into a variable.*

## Query Response



Q10

IP

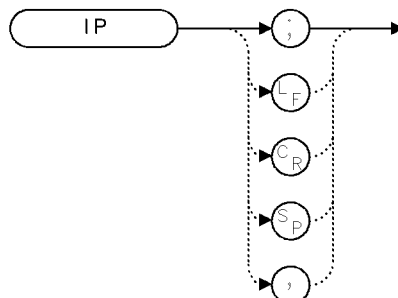
**Instrument preset** Sets all functions to their preset state.**Syntax**

XIP

**Example** Preset the HP 70810B lightwave section.

```
OUTPUT @Lws;"IP;"
```

**Description** The IP command presets the lightwave section settings. Use IP to place the HP 70810B in a known state.

Table 8-3 shows the command functions that are executed or turned off by the instrument preset command, IP.

**Table 8-3.**  
**Programming Commands Executed or Affected by Instrument Preset**

<u>Command</u>	<u>Preset State/Response</u>
AT	AT ODB
AUNITS	AUNITS DBM
CAL	Preset 1300 (850)
CALCOR	CALCOR OPTPWR OFF
ERR	Clear error register
HD	HD
MSG	Blank message
ZERO	ZERO AUTO

Instrument preset (IP) does not affect RQS, REV, SER, SRQ, or USRMSG.

# LTWAVE

**Lightwave mode** Enables lightwave or RF bypass mode.

## Syntax

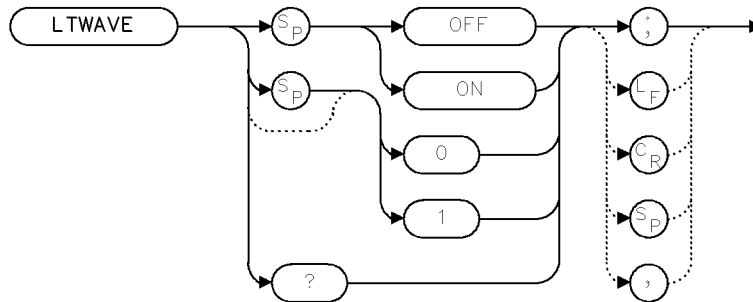

XLTWAV

Preset state: ..... Not affected by IP

Related command: ..... AUNITS

## Example

```
OUTPUT @Lws;"LTWAVE ON;"           Specifies lightwave mode.  
OUTPUT @Lws;"LTWAVE OFF;"          Specifies RF bypass mode.
```

## Description

The LTWAVE function selects either lightwave mode or RF bypass mode. With LTWAVE ON, signals at the optical input are demodulated, processed as a RF signal and sent to the RF output port.

When LTWAVE OFF is selected, RF bypass mode is activated and electrical signals at the RF INPUT port of the HP 70810B are passed directly to the RF output port. The HP 70810B lightwave section is effectively bypassed in this case.



**MSG****Message**

Returns characters contained in the message area on the HP 70810B display.

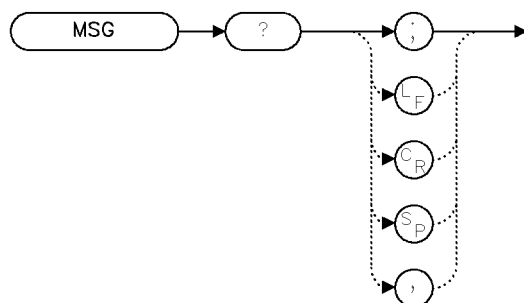
**Syntax**

XMSG

Interdependent command: ..... USERMSG

**Example** Return the message shown on the lightwave section display.

```
OUTPUT @Lws;"MSG?;"
ALLOCATE Message$[40]
```

*Return the message to the computer.*

*Create computer array (string) for storage of character message.*

```
ENTER @Lws USING "-K";Cal,Cor,Message$
```

*Assign the messages to two Boolean variables and one string. (The HP BASIC code for image, -K, enters line feeds into the string.)*

```
PRINT
IF Cal THEN PRINT "uncalibrated"
IF Cor THEN PRINT "uncorrected"
PRINT Message$[3]
```

*Print the string, beginning with the third character.*

**Description** The MSG command returns the characters shown in the message area on the display, and also returns the UNCAL and UNCOR messages if they are displayed. Whenever a message is in the message area, the Message bit of the status byte is set true.

### Query Response

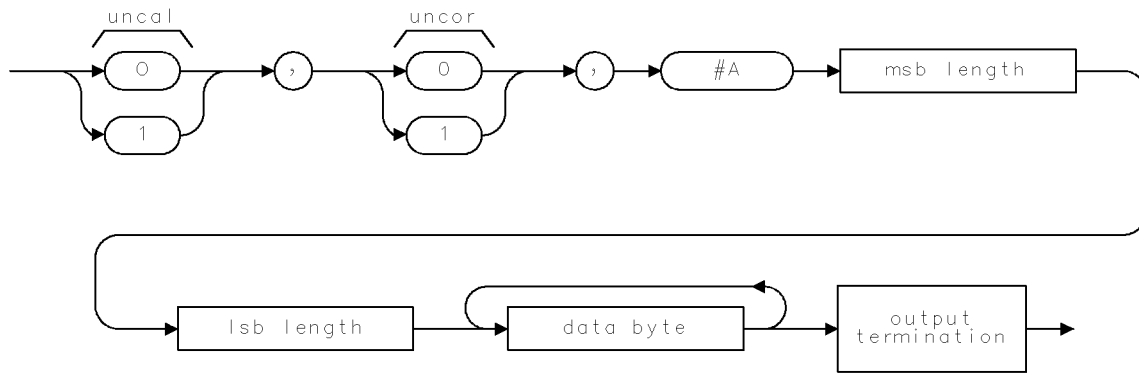

QMSG

**OPTATN**

**Optical attenuator** Controls the optical input attenuator.

**Syntax**

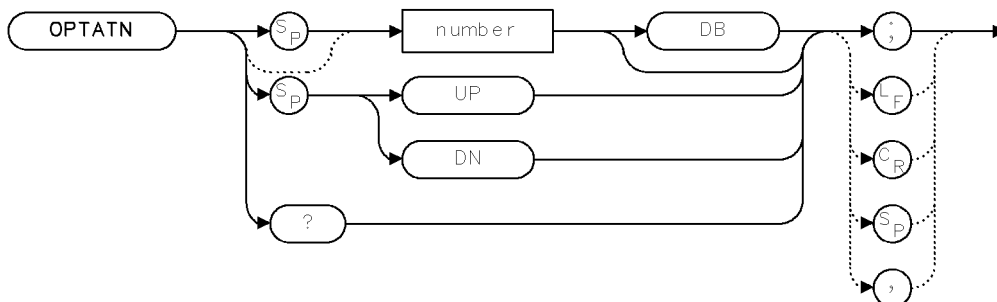

XOPTAT

Preset state: ..... 0 dB  
 Range: ..... 0 to 30 dB (optical) at 1300 nm, in 1 dB steps.  
 0 to 28 dB (optical) at 1550 nm, in 1 dB steps.  
 0 to 30 dB (optical) at 850 nm, in 1 dB steps.

**Example** Set the optical attenuator for 6 dB of attenuation.

```
OUTPUT @Lws;"OPTATN 6DB;"
```

**Description** The OPTATN command controls the optical input attenuator in the HP 70810B lightwave section. The optical input of the HP 70810B passes through a variable attenuator before being applied to the PIN photodiode. This attenuator is used to increase the dynamic range of the average optical power meter and to control the RF signal level at the RF output port.

**Query Response**



QGENF 1

# OPTCOR

**Optical frequency response corrections** Returns amplitude corrections for the HP 70810B.

## Syntax

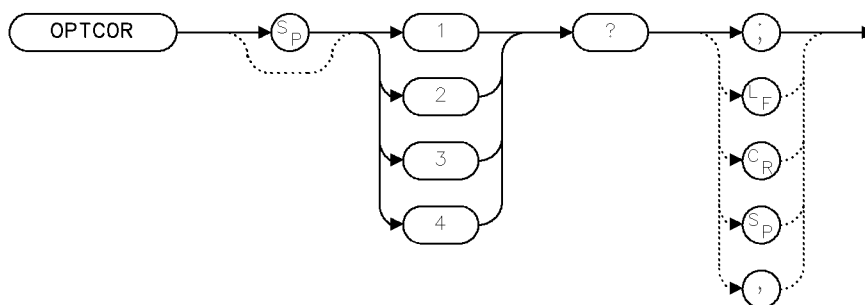

XOPTCO

Restrictions: ..... Parameters 3 and 4 are not available with firmware dated 880808.

## Example

```

OUTPUT @Lws;"OPTCOR 1?;"      Ask for lightwave section correction
                               points.
ENTER @Lws;Npts              Get number of pairs to follow.
ALLOCATE Optcor(1:Npts,1:2)  Allocate array to hold rest of data.
ENTER @Lws;Optcor(*)         Read all frequency/amplitude pairs.
  
```

## Description

There are factory-stored values for the overall frequency response (optical or RF input to RF output) of the HP 70810B lightwave section. The data is stored in frequency-amplitude pairs. For each frequency value returned (in Hz), a correction in electrical dB to the responsivity of the lightwave section is given.

Since the values returned by OPTCOR are corrections, they should be added to signal measurements, or subtracted from the responsivity. For example, if RSPSVTY? returns a value of 800 (volts per watt), and the OPTCOR value for 3.6 GHz is 6 dB, then the actual responsivity at 3.6 GHz is 6 dB below 800, or 400 volts per watt.

Parameter	Data Returned
OPTCOR 1?	returns HP 70810B lightwave path (lightwave input to RF output) correction data.
OPTCOR 2?	returns lightwave path correction data for the calibrated system option. This data applies to the combination of an HP 70810B with a specific RF or microwave input lightwave section.
OPTCOR 3?	returns correction data for the bypass path (RF input to RF output) in the HP 70810B.

OPTCOR 4? returns bypass path correction data for the calibrated system option.

**Note**

Data received is not valid if correction data is requested for the calibrated system option (parameter values of 2 or 4) from a lightwave section without that option.

**Query Response**

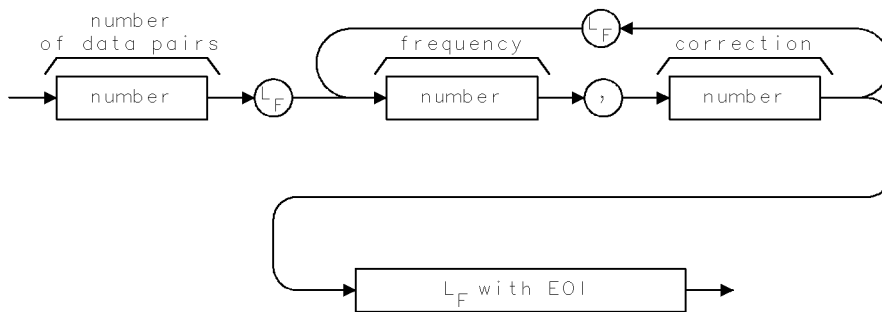

QOPTCO

# OPTPWR

**Optical power** Returns a measured value of optical power.

## Syntax

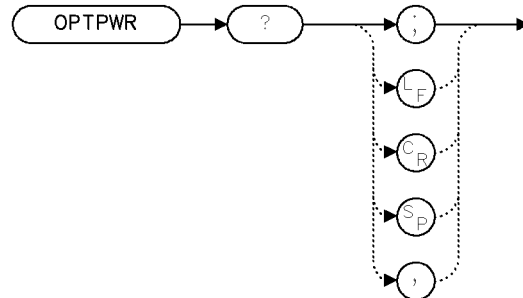

XOPTPW

Related commands: .....CAL OPTPWR, CAL PRESET

**Example** Read and display optical power from the HP 70810B.

```
OUTPUT @Lws;"OPTPWR?;"    Ask for optical power reading.
ENTER @Lws;0ptpwr        Read reply from HP 70810B.
```

**Description** The OPTPWR command returns a measured value of average optical power. Optical power measurements are made continuously by the HP 70810B lightwave section, and this command returns the first measurement to be completed after receipt of the request. HP-IB trigger commands have no effect on the rate of the optical power measurement.

Power is returned in current AUNITS (watts or dBm). If the signal-to-noise ratio at the photodiode is insufficient to make an accurate measurement, then a power level of -300 dBm is returned. This can often be remedied by decreasing the optical attenuation (OPTATN), which will result in more light at the photodiode.

If the optical power meter is overranged (too much light input), an inaccurate reading will result. The overrange bit in the status byte (STB?, or serial poll on HP-IB) will indicate this condition. The request service mask (RQS) can also be set to cause an RQS on HP-IB whenever the power meter goes overrange. This situation can be remedied by increasing the optical attenuation.

**Note** Be sure to select the correct operating wavelength with CALPRESET before making any optical power measurement.

**REV****Firmware revision**

Returns the lightwave section firmware date code.

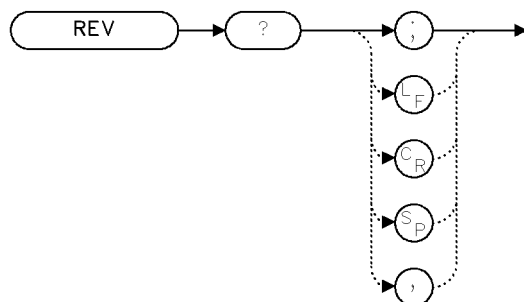
**Syntax**

XREV

**Example**

Use the REV command to find out the firmware version of the lightwave section.

```

OUTPUT @Lws;"REV?;"      Return lightwave firmware version to computer
ENTER @Lws;N             Assign firmware value to computer variable.
  
```

**Description**

The REV command returns the revision date of the HP 70810B firmware (ROM). The revision number is coded by date: year—month—day.

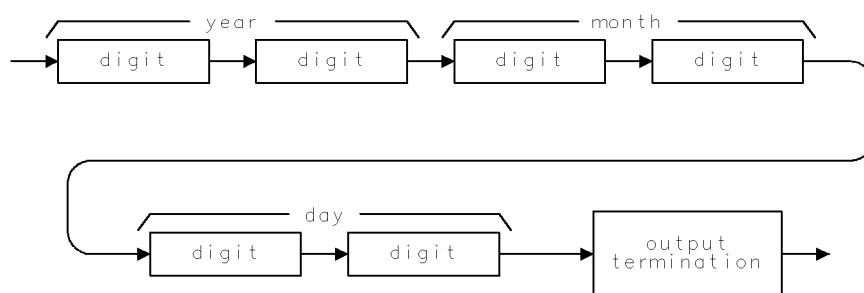
**Query Response**

QREV

# RQS

## Request service conditions

Defines conditions that cause service requests.

### Syntax

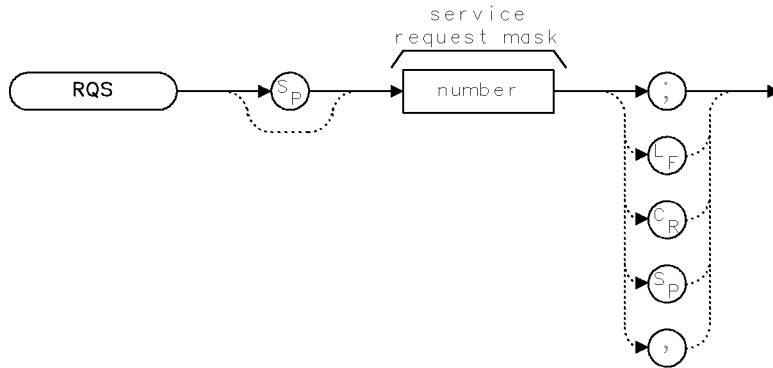

XRQS

Range: ..... Integers, 0 to 255

Related commands: .....SRQ, STB

### Example

For programming examples, refer to “Monitoring System Operation” in Chapter 4.

### Description

The RQS command specifies the **service request mask**. The service request mask determines which bits in the status byte of the analyzer will be allowed to generate a service request. Bit 6 in the status byte indicates whether or not a service request is being generated and, as such, bit 6 in the service request mask has no significance. Refer to “Monitoring System Operation” in Chapter 4 for more information (including a discussion on condition bits and event bits). The service request mask is cleared (set to 0) when the lightwave section is turned on, and also when the lightwave section receives a “device clear” (HP BASIC CLEAR statement) on HP-IB. Table 8-4 describes the bit assignments within the service request mask.



**Table 8-4. Lightwave Section Status Byte**

<b>Bit Number</b>	<b>Decimal Equivalent</b>	<b>Analyzer State</b>	<b>Description</b>	<b>Bit Type</b>
7	128	OUT OF RANGE	Optical power is out of range for optical average power meter (too low or too high).	event
6	64	RQS	Set when service request is being generated.	—
5	32	ERROR-PRESENT	Set when error register contains an error.	condition
4	16	COMMAND-COMPLETE	Set at completion of command execution.	event
3	8	ZEROING	Optical power meter is executing its zeroing function.	condition
2	4	Not used		
1	2	MESSAGE	Set when messages appear in the display message area.	condition
0	1	Not used		

# RSPSVTY

**Responsivity** Returns the overall responsivity of the HP 70810B.

## Syntax

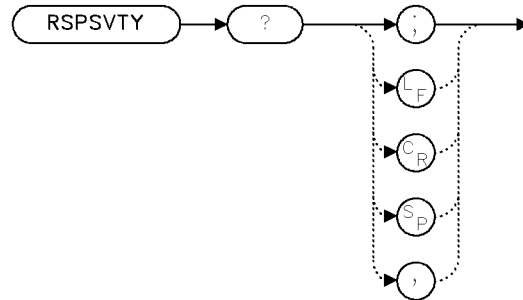

XRSPSV

Restrictions: ..... Available only in lightwave mode (LTWAVE ON)

## Example

```
OUTPUT @Lws;"RSPSVTY?;"  
ENTER @Lws;Rsp
```

## Description

This command is used in lightwave mode (LTWAVE ON) to query the HP 70810B's overall responsivity.

The responsivity values indicate conversion from the optical input to the RF output of the HP 70810B. The optical attenuator setting will affect responsivity.

SER

**Serial number** Stores and returns the instrument serial number.

**Syntax**

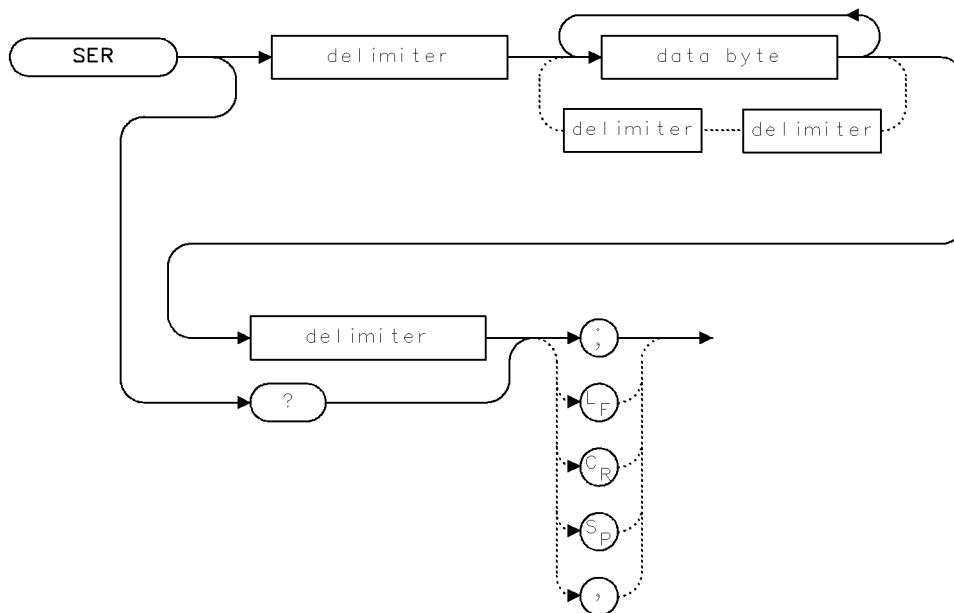

Range: ..... Maximum of 21 characters

**Example**

```
DIM SER$[21]
OUTPUT @Lws;"SER$Your #1 Analyzer$;"
OUTPUT @Lws;"SER?;"
ENTER @Lws;Ser$
```

**Description**

The SER command stores the serial number of the lightwave section in memory. SER may be used to return the stored number to the computer. This is originally the ten-character serial number assigned to the lightwave section by Hewlett-Packard. This serial number may be loaded with whatever data is convenient.

If the HP 70810B is part of a calibrated system, this serial number is used to determine if valid system calibration is available.

**Query Response**

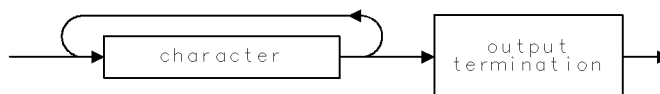

QSER

# SRQ

## Service request

Sets bit(s) in the status byte to simulate a service request.

### Syntax

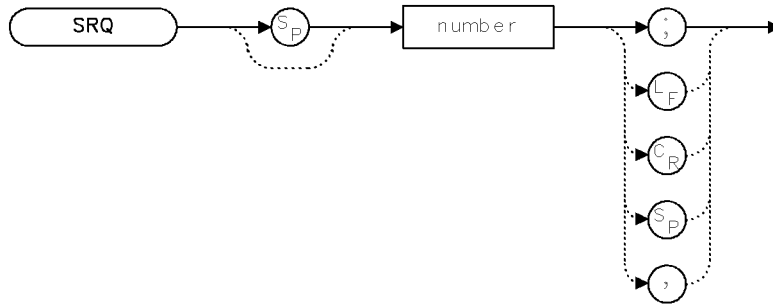

XSRQ

Range: .....0 to 255

### Description

The SRQ command simulates service requests by setting bits in the status byte. Use the SRQ command to test the operation of programs containing service requests. For example, suppose your program branched to a subroutine whenever a lightwave section error was detected. Instead of testing the program by initiating lightwave section errors, execute SRQ 32 to simulate an error condition.

See the descriptions for the RQS and STB commands. See also "Monitoring System Operation" in Chapter 4.

**Table 8-5. Lightwave Section Status Byte**

<b>Bit Number</b>	<b>Decimal Equivalent</b>	<b>Analyzer State</b>	<b>Description</b>	<b>Bit Type</b>
7	128	OUT OF RANGE	Optical power is out of range for optical average power meter (too low or too high).	event
6	64	RQS	Set when service request is being generated.	—
5	32	ERROR-PRESENT	Set when error register contains an error.	condition
4	16	COMMAND-COMplete	Set at completion of command execution.	event
3	8	ZEROING	Optical power meter is executing its zeroing function.	condition
2	4	Not used		
1	2	MESSAGE	Set when messages appear in the display message area.	condition
0	1	Not used		

# STB

**Status byte** Returns the value of the status byte register.

## Syntax

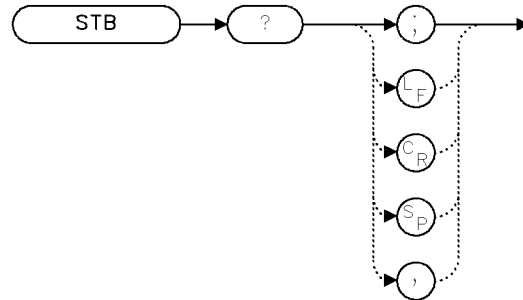

XSTB

Related command: ..... SRQ

**Example** Monitor lightwave section operation without using service-request methods.

OUTPUT @Lws;"STB?;" *Return status of status byte, then clear it. The value returned is the sum of 16 (command complete), 4 (end-of-sweep), and 1 (trigger armed), which equals 21.*

ENTER @Lws;N *Assign value to computer.*

OUTPUT @Lws;"STB?;" *Return status of status byte. Value returned is 16 (command complete), since this is the only task the lightwave section has performed since the status byte was cleared.*

ENTER @Lws;M

**Description** Use the STB command to monitor lightwave section operation. Certain multiple-tasking computer systems, such as UNIX-based computers, monitor lightwave section operation more efficiently with the STB command than with the service-request command, RQS.

Use STB to monitor lightwave section operation randomly at any time. Executing STB is similar to conducting a serial poll of the status byte. When STB is executed, the status byte is cleared (all bits set to zero).

The STB command returns the decimal equivalent of the status byte. For example, the COMMAND-COMPLETE and ERROR-PRESENT bits are set when 48 (16 + 32) is returned.

Executing STB? always sets the command-complete bit. For this reason, STB cannot be used to monitor the completion of commands. See the description for the DONE command.

Refer to "Monitoring System Operation" in Chapter 4 for more information.

**Table 8-6. Lightwave Section Status Byte**

<b>Bit Number</b>	<b>Decimal Equivalent</b>	<b>Analyzer State</b>	<b>Description</b>	<b>Bit Type</b>
7	128	OUT OF RANGE	Optical power is out of range for optical average power meter (too low or too high).	event
6	64	RQS	Set when service request is being generated.	—
5	32	ERROR-PRESENT	Set when error register contains an error.	condition
4	16	COMMAND-COMPLETE	Set at completion of command execution.	event
3	8	ZEROING	Optical power meter is executing its zeroing function.	condition
2	4	Not used		
1	2	MESSAGE	Set when messages appear in the display message area.	condition
0	1	Not used		

# TEST

**Self test**      Executes a self-test.

## Syntax

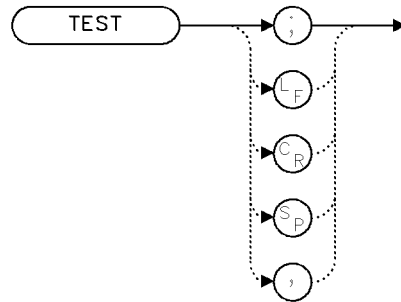

XTEST

**Example**      Use TEST to conduct the self test.

```
110 OUTPUT @Lws;"TEST;"    Conduct the self test.
```

The TEST command tests the functionality of the power meter and the optical attenuator and reports any errors to the error register. The lightwave section returns to its previous state when the test is complete.

Execute ERR? to return error codes to the controller. Use IP or ERR? to clear the error register where errors are recorded.

The system-level command, device-clear, stops the test. The device-clear command in HP BASIC is CLEAR 720 for a lightwave section at HP-IB address 20 on interface 7.



**USERMSG**

**User message** Writes a message on the system display; the message is cleared at your discretion.

**Syntax**

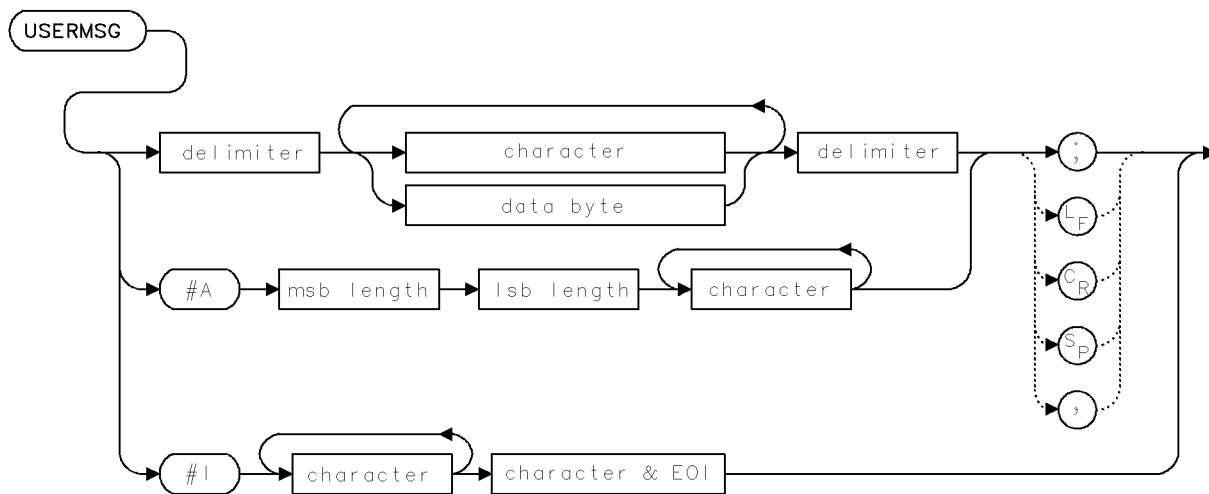

XUSERM

Requirements: ..... Requires internal memory.  
See Appendix D for commands that consume memory.

Interdependent command: ..... MSG

**Example** Write a message in the message area.

```
OUTPUT @Lws;"USERMSG @Adjust modulation level.@;"
```

**Description** The USERMSG command writes a message of 39 characters or less in the message area on the display. The message is cleared by pressing any key, or executing IP or MSG?.

# XERR

**Extended error query** Returns a description of an error and the error-reporting module.

## Syntax

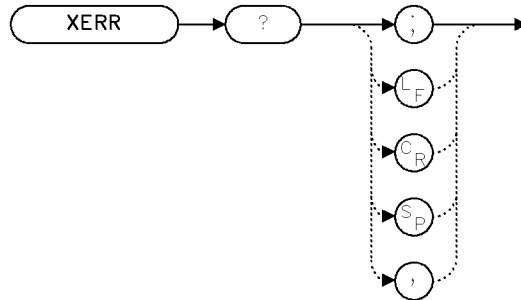

XXERR

Interdependent command: ..... IP clears errors from the register

**Example** Use XERR to return an error report to the computer.

```

ALLOCATE Error$[200]
OUTPUT @Lws;"JKLD;"           Send the lightwave section a
                               meaningless command.

OUTPUT @Lws;"WAIT 2S;"       Wait two seconds.
OUTPUT @Lws;"XERR?;"        Return reported errors to computer.
ENTER @Lws USING "-K";Error$ Store error messages in string
                               variable, accepting line feeds.

PRINT Error$                 Print error report on computer.

```

**Description** The XERR command returns error information when an instrument encounters an error. Information returned includes the name and HP-MSIB address of the module reporting the error, the error code, and a description.

### Query Response

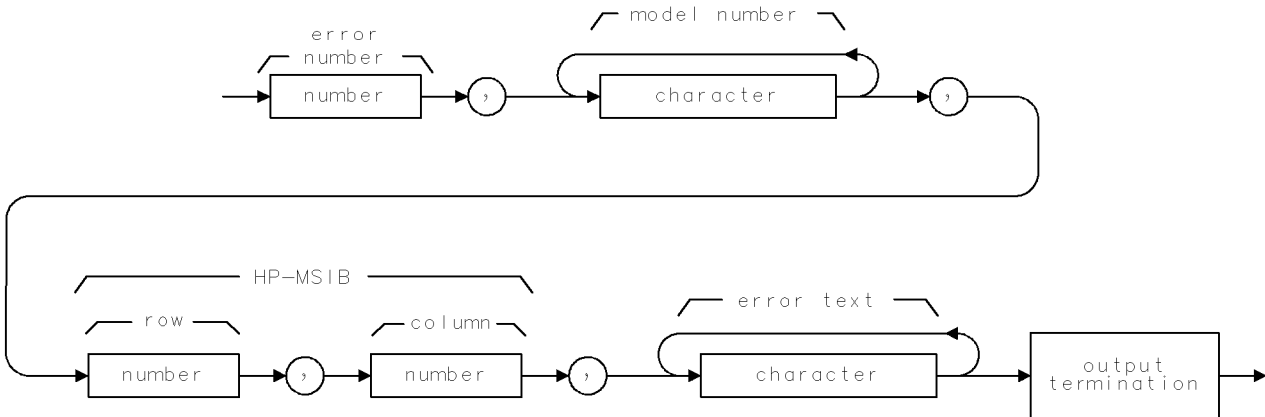

QXERR

# ZERO

**Optical power meter zeroing** Zeroes the optical power meter.

## Syntax

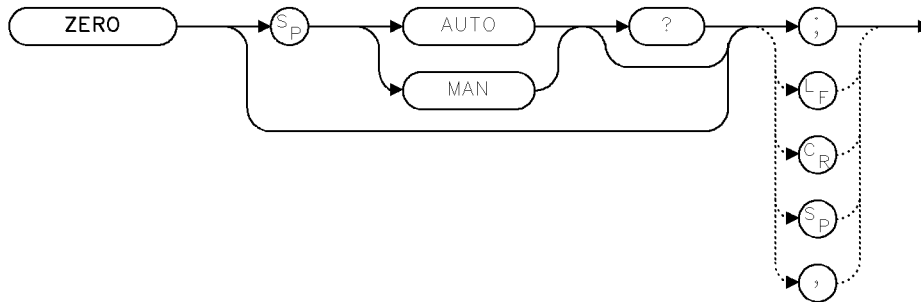

XZERO

Preset state: ..... AUTO

## Example

```
OUTPUT @Lws;"ZERO MAN;"      Select manual zeroing.
OUTPUT @Lws;"ZERO AUTO?;"    Ask analyzer if zeroing is in AUTO
                               mode.
ENTER @Lws;N                  Enter analyzer reply into program
                               variable.
```

## Description

The optical power meter must be adjusted periodically to compensate for the PIN photodiode's dark current. The zeroing algorithm can be invoked automatically at fixed periodic intervals or on command. With ZERO AUTO in effect, zeroing will be done periodically, at intervals determined by the optical power present at the photodiode (lower power levels cause more frequent zeroing). If a ZERO command is received while in ZERO AUTO mode, the zeroing algorithm will be executed immediately and a new zeroing interval will be computed based on the time of the forced zero. A ZERO' command in ZERO AUTO mode does not turn off auto-zeroing.

In ZERO MAN mode, zeroing will only be done when a ZERO or ZERO MAN command is received. A ZERO AUTO command in manual zeroing mode will cause an immediate zeroing, and resumption of automatic, periodic zeroing.

## Note

Using manual zeroing mode may cause inaccurate power measurements if zeroing is not done often enough.

Zeroing causes the light to be blocked. Any RF signal output from the lightwave will likewise be removed.

### Query Response

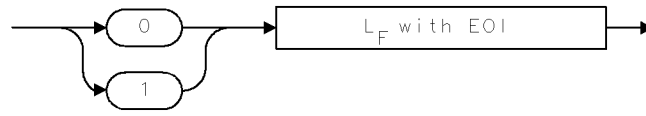

QGENF2

ZERO

## Error Messages

---

This chapter provides module-level troubleshooting information for the HP 70810B lightwave section when it is configured for stand-alone operation.

---

### What You'll Find in This Chapter

Troubleshooting Features .....	page 9-2
Catastrophic Failures .....	page 9-4
Troubleshooting a Lightwave Section .....	page 9-5
Error Message Descriptions .....	page 9-6

#### Note

---

System-level troubleshooting information for a lightwave signal analyzer is contained in the *HP 70000 Modular Spectrum Analyzer Operation Manual for HP 70900B Local-Oscillator-Controlled Modules*.

---

---

## Troubleshooting Features

This section assumes an understanding of the terminology listed in “Modular Measurement System Terminology” in Chapter 11.

### Display Status Indicators

The error- and active-status indicators for a display are the letters E and A in the upper left corner of the display in the display status block. All other elements have ERR and ACT indicators on the front panel.

The HP 70206A system graphics display has an I/O error indicator that lights when only one HP-MSIB cable is connected to the HP 70206A. The indicator is off if both cables are either connected or disconnected. The HP 70001A mainframe has an I/O error indicator that functions in the same manner. The HP 70004A also has a front-panel I/O error indicator labeled “HP-MSIB.”

Refer to the “Troubleshooting Catastrophic Failures” section in the *HP 70000 Modular Spectrum Analyzer Operation Manual, for HP 70900B Local-Oscillator-Controlled Modules* for more information about the I/O indicator.

### Lightwave Section Status Indicators

The lightwave section has two types of status indicators. ERR (error) indicators indicate a fault of some kind. ACT (active) indicators show that the lightwave section is active, that it is being controlled or accessed.

The HP 70810B lightwave section front panel contains four indicators that flag HP-IB activities:

- RMT (remote)
- LSN (listen)
- TLK (talk)
- SRQ (service request)

#### Status Error Indicators

A fault in a lightwave section lights the ERR indicator. The ERR indicator goes out when the fault condition is cleared and is reported.

A fault in the lightwave section also causes the appearance of the E indicator on the display. This occurs because the lightwave section row address is set to 0 for stand-alone operation causing the error to be reported to the display.

An ERR indicator flashing slowly at about 1 Hz means the lightwave section cannot communicate on the HP-MSIB. The module is probably defective if the ERR (error) indicator is flashing in this manner.

#### Note

If more than one instrument is installed in the mainframe and is flashing its ERR indicator, it is possible that the ERR indicator is not flashing on a faulty module that has disrupted all HP-MSIB communication.

---



### **Active Indicators**

The ACT LED indicates use of the element through the display keyboard. The ACT LED will also flash during the power-on self-test.

Pressing the **DISPLAY** key causes appearance of the  $\#$  indicator in the display status block.

When the address map cursor is at the address of an element, the element's active indicator lights. It is thus possible to determine an element's address by scrolling through the map.

---

## Catastrophic Failures

Catastrophic failures usually result in a blank or distorted display on the screen, flashing error LEDs, or no displayed menu softkeys.

Cycle the power of the display and observe the screen display. If the failure symptoms continue, remove the lightwave section from the display or mainframe. If the display section exhibits failure symptoms, refer to the appropriate display manual for further troubleshooting information. If the display operates normally, either the lightwave section is defective or there is a HP-MSIB problem.

For more information about troubleshooting catastrophic failures, refer to the section “Troubleshooting Catastrophic Failures” in the troubleshooting chapter of the *HP 70000 Modular Spectrum Analyzer Operation Manual for HP 70900B Local-Oscillator-Controlled Modules*.

---

## Troubleshooting a Lightwave Section

Troubleshooting the lightwave section is simplified due to the limited functionality of the lightwave section when it is configured for stand-alone operation. This section assumes that the display is operating normally.

### Note

---

Verification software for the HP 70810B lightwave section is not available to customers because of specialized and expensive test-equipment requirements.

---

If error messages are displayed, refer to “Error Message Descriptions” for an explanation of the displayed error messages. When error messages occur that indicate a hardware failure, it is likely that the lightwave section has failed.

If further troubleshooting is necessary to verify functionality of the lightwave section module and isolate a lightwave section problem, perform the following procedures as necessary:

- To verify the basic functionality of a lightwave section, perform the test procedure located in “Verifying Basic Functions” in Chapter 2.
- To verify power meter response to a calibrated optical signal, an additional optical power meter is required.
  1. Calibrate the optical power meter.
  2. Using the calibrated optical power meter, measure the intensity of the lightwave source.
  3. Measure the average power output of the lightwave source using the HP lightwave section.
  4. Compare the power levels measured by the optical power meter and the lightwave section. Any differences between the measured levels should be within the related specifications that are listed in Chapter 5.

If the lightwave section is defective, contact your local Hewlett-Packard service office. The procedure for returning and instrument for service is described in “Returning the Module for Service” in Chapter 1.

---

## Error Message Descriptions

This section lists error messages originating in the HP 70810B lightwave section when it is operated in stand-alone mode.

These error messages are grouped by functional category; each category has its own series of numbers. A definition of the functional category is given at the beginning of each error message listing.

Types	Numbers
Operating	2000 to 2999
Computation	4000 to 4999
Hardware-Warning	6000 to 6999
Hardware-Broken	7000 to 7999
Factory Use Only	9000 to 9999

The lightwave module displays error messages that can also be retrieved via HP-IB by executing the ERR programming command.

Operating, hardware-warning, hardware-broken, and computation error messages report the element model number and HP-MSIB address of the module that is generating the error condition.

### Operating Errors 2000 to 2999

Operating errors occur when the lightwave section module is operated incorrectly.

2001 Illegal command

**Cause:** The remote command sent over the bus or executed as part of a DLP was not a legal remote command. This error could also occur if a user variable (VARDEF), which did not exist, was used as a parameter in a remote command. Check for missing terminators, and the proper number of parameters. Also verify that delimited strings are properly ended.

**Cure:** Use the DEBUG command to locate the programming error. Refer to the DEBUG command description in the *HP 70000 Modular Spectrum Analyzer Programming Manual*.

2003 Missing parameter

**Cause:** The command being executed requires more parameters than were provided, or a user variable VARDEF used as a parameter for a function was not found.

**Cure:** Use the DEBUG command to locate the programming error. Refer to the DEBUG command description in the *HP 70000 Modular Spectrum Analyzer Programming Manual*.

2006 Parm out of range

**Cause:** A change was made to an instrument setting that was beyond the capabilities of the hardware. This could be remote, DLP, or front panel changes.

**Cure:** Use the DEBUG command to locate the programming error. Refer to the DEBUG command description in the *HP 70000 Modular Spectrum Analyzer Programming Manual*.

2011 Memory overflow

**Cause:** There is not enough available memory for the operation. Examples would be adding a VARDEF, FUNCDEF, or ACTDEF sending AMPCOR data adding new modules to a system that was almost out of memory because of FUNCDEFs, etc.

**Cure:** Some items must be removed from memory. Analyze DLP's to see if there are extra characters (spaces, etc.) that could be removed. Expanded memory options for the Local Oscillator are also available.

2018 State protected

**Cause:** This error occurs if a user stored instrument state that is protected was requested to be removed from memory. The state will not be removed. Also, if the number of user states is reduced using NSTATE, all states above the requested number will be deleted. If any of those states were protected, the NSTATE command will be ignored and this error will occur.

**Cure:** Unprotect any states no longer needed.

2023 Illegal Cal signal

**Cause:** Calibration signal did not match.

2031 Too many errors

**Cause:** The error buffer has been filled.

2032 Hardware not present

**Cause:** A function was requested that required hardware not available in the system.

**Cure:** Use the DEBUG command to locate the programming error. Refer to the DEBUG command description in the *HP 70000 Modular Spectrum Analyzer Programming Manual*.

2035 Illegal operation

**Cause:** The command is not possible or does not affect the current measurement conditions.

**Cure:** Use the DEBUG command to determine which command generated the error. Refer to the DEBUG command description in the *HP 70000 Modular Spectrum Analyzer Programming Manual*.

2802 Illegal in LW mode

**Cause:** The last command sent to the HP 70810B is legal in bypass mode only.

2803 Illegal in bypass

**Cause:** The last command sent to the HP 70810B is legal in lightwave mode only.

## Computation Errors 4000 to 4999

The following error messages indicate that a computation error has occurred. The error is the result of illegal math operations performed by the lightwave section firmware.

A computation error message generally indicates that a RAM failure has occurred or there is a design error in the firmware.

4000 Divide by zero

4001 Float overflow

**Cause:** Floating-point overflow. Absolute value of number exceeds  $1.7 \times 10^{308}$ .

4002 Float underflow

**Cause:** Floating-point underflow. Absolute value of number is between 0 and  $\pm 2.2 \times 10^{-308}$ .

4003 Logarithm error

**Cause:** A logarithmic calculation was performed on a number less than or equal to zero.

4004 Integer overflow

**Cause:** A number exceeded the range of an internal integer variable. The number is less than  $-32,768$  or greater than  $32,767$ .

4005 Square root error

**Cause:** Calculation attempted to take the square root of a negative number.

## Hardware Warning Errors 6000 to 6999

Hardware-warning errors occur when the hardware is faulty. The spectrum analyzer can still make measurements, but the accuracy of the measurement cannot be guaranteed.

6802 Invalid cal data

**Cause:** The EAROM data installed during the manufacturing process may not be valid.

**Cure:** Return to Hewlett-Packard for servicing.

6805 Firmware changed

**Cause:** The HP 70810B firmware version is of a different date code than was installed in the module the last time it was turned on. All user optical power calibration data previously stored in module memory has been lost.

**Cure:** Perform a calibration on the HP 70810B.

6806 Avg pwr over-range

**Cause:** The average power reading is invalid because the input signal is above the supported measurement range of the power meter.

**Cure:** Reduce the input signal level. To eliminate the displayed error message, clear the error bit for the status-byte register either by sending a remote query (ERR? or ERR?) or by pressing a front-panel key on the analyzer.

## Hardware-Broken Errors 7000 to 7999

Hardware-broken errors indicate that the lightwave section probably has faulty hardware.

7801 Optical atten failed

**Cause:** The optical attenuator cannot achieve a given setting. Automatic periodic zeroing temporarily modifies the attenuator setting, so this error can occur without a user attempt to change attenuation.

7802 ADC error

**Cause:** The analog digital converter (ADC) in the power meter is not responding.

7803 Power meter failed

**Cause:** The power meter circuitry has failed during the self test.

7804 Self test failed

**Cause:** The self test checks the functionality of the power meter and optical attenuator.

7805 Zeroing error

**Cause:** Photodiode dark current cannot be nulled. Suspect a hardware problem such as excessive noise on the photodiode, or catastrophic failure in the power meter circuitry.

## **Factory-Use Only Errors 9000 to 9999**

These errors are for factory use only. If any of the 9000 to 9999 errors occur, do the following:

- Record the error number and the hexadecimal code.
- Record all events that led up to the occurrence of the error message.
- Record the HP model numbers of the modules in the system.
- Record the firmware version.
- Contact the nearest HP sales and service office for assistance.



## Tables and Charts

---

This chapter lists options and accessories and tells you how to contact an HP sales and service office.

---

### What You'll Find in This Chapter

Instrument Options .....	page 10-2
Service Kit Accessories .....	page 10-3
Contacting HP Sales and Service Offices .....	page 10-4

---

## Instrument Options

<b>Option 850</b>	Lightwave operation from 750 nm to 870 nm
<b>Option 011</b>	Diamond HMS-10/HP connector interface
<b>Option 012</b>	FC/PC connector interface
<b>Option 013</b>	DIN 47256 connector interface
<b>Option 014</b>	ST connector interface
<b>Option 015</b>	Biconic connector interface
<b>Option 020</b>	System adjustment and calibration with RF section
<b>Option 910</b>	Extra copy of lightwave manual
<b>Option 098 or 099</b>	System LO firmware upgrade (This option is required if your instrument's current date code is earlier than 911021. Contact a Hewlett-Packard sales and service office.)

Additional connector interfaces not listed above are available from the HP catalog.

## Accessories Supplied with the Product

The HP 70810B lightwave section is available separately or as a component in a preconfigured system. When ordered separately, the accessories supplied allow the most common system configurations. Table 10-1 lists accessories being shipped with the HP 70810B at print date.

Contact a Hewlett-Packard sales and service office for a description of all accessories currently shipped with the HP 70810B. In a preconfigured system, the provided RF cables match the factory configuration.

**Table 10-1. Accessories Shipped with the HP 70810B**

<b>Description</b>	<b>Qty</b>	<b>Part Number</b>
Cable, semi-rigid, Type N (m) to SMA (m) (used with an HP 70908A)	1	5021-8629
Cable, semi-rigid, Type N (m) to SMA (m) (used with an HP 70904A)	1	5021-8651
Cable, flexible, SMB (f) to SMB (f)	1	8120-5023
Cable, semi-rigid, SMA (m) to SMA (m) (used only with a second HP 70810B; RF OUTPUT to RF INPUT)	1	70810-20023
Connector adapter, SMA (m) to BNC (f)	1	1250-1200
SMB tee (f)(m)(m)	1	1250-1391

---

## Service Kit Accessories

**Table 10-2.**  
**HP 71000 System Service Kit (HP Part Number 71000-60002)**

<b>HP Part Number</b>	<b>Qty</b>	<b>Description</b>
71000A-1	1	Service note
70001-60013	1	Lightwave section service extender
8710-1651	1	8 mm hex-ball driver
8710-1728	1	Bandpass filter tuning tool
5021-6773	1	Cable puller
5021-7445	1	Pin straightener
85680-60093	3	Cable assembly BNC (m) to SMB (f)
5061-9021	7	Flex cable assembly SMB connectors
70001-00038	1	Module cover, right side
70001-00039	1	Module cover, left side
8160-0495	2.0 ft	Gasket (2.54 x 1.57 mm)
8160-0035	2.0 ft	RFI shielding (STR.0940)
8160-0484	10.0 ft	RFI shielding (BEC.125D)
2110-0695	10	Fuse 1.5A 125V
2110-0700	10	Fuse 1A 250V
2110-0701	10	Fuse 1.6A 250V
2110-0703	10	Fuse 6.3A 250V
2110-0710	10	Fuse 2.0A 250V

---

## Contacting HP Sales and Service Offices

Hewlett-Packard sales and service offices provide worldwide support for Hewlett-Packard products. To obtain servicing information or to order replacement parts, contact the nearest office listed in Table 10-3. In any correspondence, always provide essential information, which includes model numbers, serial numbers, and assembly part numbers.

**Table 10-3. Hewlett-Packard Sales and Service Offices**

US FIELD OPERATIONS		
<p><b>Headquarters</b> Hewlett-Packard Company 19320 Pruneridge Avenue Cupertino, CA 95014, USA (800) 752-0900</p>	<p><b>California, Northern</b> Hewlett-Packard Co. 301 E. Evelyn Mountain View, CA 94041 (415) 694-2000</p>	<p><b>California, Southern</b> Hewlett-Packard Co. 1421 South Manhattan Ave. Fullerton, CA 92631 (714) 999-6700</p>
<p><b>Colorado</b> Hewlett-Packard Co. 24 Inverness Place, East Englewood, CO 80112 (303) 649-5000</p>	<p><b>Georgia</b> Hewlett-Packard Co. 2000 South Park Place Atlanta, GA 30339 (404) 955-1500</p>	<p><b>Illinois</b> Hewlett-Packard Co. 5201 Tollview Drive Rolling Meadows, IL 60008 (708) 255-9800</p>
<p><b>New Jersey</b> Hewlett-Packard Co. 150 Green Pond Road Rockaway, NJ 07866 (201)627-6400</p>	<p><b>Texas</b> Hewlett-Packard Co. 930 E. Campbell Rd. Richardson, TX 75081 (214) 231-6101</p>	
EUROPEAN FIELD OPERATIONS		
<p><b>Headquarters</b> Hewlett-Packard S.A. 150, Route du Nant-d'Avril 1217 Meyrin 2/Geneva Switzerland (41 22) 780.8111</p>	<p><b>France</b> Hewlett-Packard France 1 Avenue Du Canada Zone D'Activite De Courtaboeuf F-91947 Les Ulis Cedex France (33 1) 69 82 60 60</p>	<p><b>Germany</b> Hewlett-Packard GmbH Hewlett-Packard Strasse 6380 Bad Homburg v.d.H Germany (49 6172) 16-0</p>
<p><b>Great Britain</b> Hewlett-Packard Ltd Eskdale Road, Wimmersh Triangle Wokingham, Berkshire RF11 5DZ England (44 734) 696622</p>		
INTERCON FIELD OPERATIONS		
<p><b>Headquarters</b> Hewlett-Packard Company 3495 Deer Creek Rd. Palo Alto, California 94304-1316 (415) 857-5027</p>	<p><b>Australia</b> Hewlett-Packard Australia Ltd. 31-41 Joseph Street Blackburn, Victoria 3130 (61 3) 895-2895</p>	<p><b>Canada</b> Hewlett-Packard (Canada) Ltd. 17500 South Service Road Trans-Canada Highway Kirkland, Quebec H9J 2X8 Canada (514) 697-4232</p>
<p><b>China</b> China Hewlett-Packard Co. 38 Bei San Huan XI Road Shuang Yu Shu Hai Dian District Beijing, China (86 1) 256-6888</p>	<p><b>Japan</b> Yokogawa-Hewlett-Packard Ltd. 1-27-15 Yabe, Sagamihara Kanagawa 229, Japan (81 427) 59-1311</p>	<p><b>Singapore</b> Hewlett-Packard Singapore (Pte.) Ltd 1150 Depot Road Singapore 0410 (65) 273-7388</p>
<p><b>Taiwan</b> Hewlett-Packard Taiwan 8th Floor, H-P Building 337 Fu Hsing North Road Taipei, Taiwan (886 2) 712-0404</p>		



## Configuring and Addressing

---

This chapter explains how to address one or more HP 70810B lightwave sections for stand-alone operation and provides general addressing information for modular measurement systems.

---

### What You'll Find in This Chapter

HP-MSIB and HP-IB Addressing .....	page 11-2
Modular Measurement System Terminology .....	page 11-3
Address Matrix .....	page 11-4
Address Switches .....	page 11-6
Address Map for Stand-Alone Operation .....	page 11-8

---

## HP-MSIB and HP-IB Addressing

An **element** in an HP 70000 modular measurement system is a **system component** able to communicate with other modules over HP-MSIB. Element addresses must adhere to the set of rules defined in this section (HP-MSIB addressing differs from HP-IB addressing). For system addressing information, refer to the *HP 70000 Modular Spectrum Analyzer Installation and Verification Manual for HP 70900B Local-Oscillator Controlled Modules*.

Correct addressing requires an understanding of basic system terminology and of the following three concepts:

- |                         |   |
|-------------------------|---|
| <b>Address matrix</b>   | A graphic representation showing address assignments and how modules on the matrix relate to one another. |
| <b>Address protocol</b> | Distinctions among master, slave, and independent elements.   |
| <b>Address switches</b> | Techniques that set an element address.   |



---

## Modular Measurement System Terminology

The functional and structural terms in this subsection are essential to understanding HP-MSIB addressing and the structural relationships among modular measurement system devices.

The HP 70810B lightwave section can function as either a slave element (in a lightwave signal analyzer) or as an independent element (stand-alone operation).

<b>Functional Terms</b>	<b>Element</b>	Any device that communicates over the HP-MSIB (The HP 70001A Mainframe controls all communications over HP-MSIB but does not communicate over HP-MSIB; therefore, the mainframe is not an element.)
	<b>Instrument</b>	An element or group of elements that performs an independent function. (The element can be a master, a master with slaves, or an independent.)
	<b>Slave</b>	An element controlled by another element.
	<b>Master</b>	An element that controls other elements.
	<b>Sub-Master</b>	An element capable of functioning as both slave and master at the same time.
	<b>Independent</b>	An element that is neither a master nor a slave (for example, a display or a lightwave module set for stand-alone operation).
<b>Structural Terms</b>	<b>Mainframe</b>	A housing for modules. (It supplies power, interconnection for HP-MSIB and HP-IB, and HP-MSIB communications control.)
	<b>Module</b>	A system modular measurement system component that plugs into a mainframe.
	<b>Stand-alone instrument</b>	An element that can perform its function independently of a mainframe (for example, the HP 70206A system graphics display).

## Address Matrix

The address matrix, as Figure 11-1 shows, is a graphic representation of addresses on the HP-MSIB. The 8-row by 32-column matrix implies 256 available addresses; however, there are actually 255 legal addresses plus an illegal address at row 0, column 31.

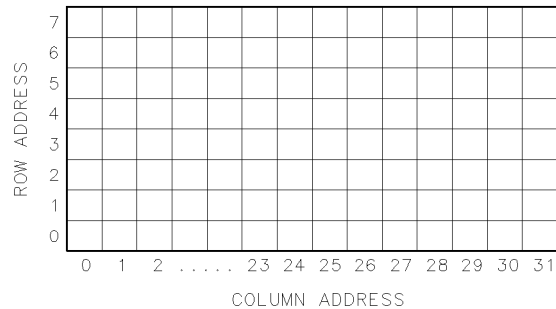

**Figure 11-1. The Address Matrix**

Each element must have a unique 8-bit binary HP-MSIB address correctly placed on the address matrix. The three MSB (most significant bits) determine the row address; the five LSB (least significant bits), the column address. This manual refers to the decimal equivalent of a binary address (see Table 11-1).

**Table 11-1. Decimal Equivalent of Binary Address**

	Row MSB	Column LSB
<b>Binary</b>	010	11000
<b>Decimal</b>	2	24

### HP-IB Access Area

The placement of an element on the address matrix is one factor that determines whether an element has HP-IB access and whether it will respond to display queries. Addresses 0,0 through 0,30 are the **HP-IB access area**, allowing HP-IB communications for elements with HP-IB capabilities.

### Display-Response Area

If there is a display on the HP-MSIB, row 0 becomes the **display-response area**. In this case, the only elements addressed at row 0 should be those that both interface with the display and also report errors (for example, HP 70810B, HP 70900A/B, and HP 70700A).

## Display Communication Capabilities

Assignment of a display window or keyboard establishes a communications link between the display and an element. An element can accept a display assignment if the element is at a legal address, has a display interface, and can report errors. Thus independent elements such as the HP 70810B can accept a display assignment.

To assign a display to the element with the lowest row 0 column address, press **DISPLAY**, then **NEXT INSTR**. To assign to the element with the next-highest column address, press the **□** step key or press **NEXT INSTR** again. If an element is at row 0 and has a column address higher than the column address of the display, then that element can report errors to the display using either the automatic error-reporting routine or the **REPORT ERRORS** softkey. Refer to Chapter 4 for error-reporting details during remote operation.

---

## Address Switches

The address switches set an element's HP-MSIB address. If the element is a master or an independent element, the column switches also determine the HP-IB address. Softkeys are a second way to set the HP-IB address on many elements under certain conditions (soft-set HP-IB addresses).

### HP 70810B Address Switches

There are three switches on top of the HP 70810B at the right-hand rear corner. See Figure 11-2.

- The HP-IB switch enables and disables HP-IB communications.
- The eight-section switch sets the HP 70810B addresses. Sections one through five set both the HP-IB address and the HP-MSIB column address. The three front sections (6, 7, and 8) set the HP-MSIB row address. Figure 11-2 illustrates a module address set at row 0, column 20.
- The four-section switch at the top of the address switches has no effect on operation.

### Soft-Set HP-IB Addresses

The user can set HP 70810B HP-IB address from the front panel. This soft-set address is in effect until the user changes either the hard address switches or the soft-set address.

This procedure enters a soft-set HP-IB address:

1. Press **DISPLAY** on the front panel.
2. When the menu appears, press **address map**.
3. When the next menu appears, use the knob or **↑** or **↓** to select the desired instrument.
4. Press **HP-IB ADDRSET**.
5. Use the display numeric keys to enter the new HP-IB address.
6. Press **ENTER**.

### Default Address

The factory selected address default for the module used in HP 71400C and HP 71401C systems is row 3, column 20. For standalone operation, the row address should be changed to 0.

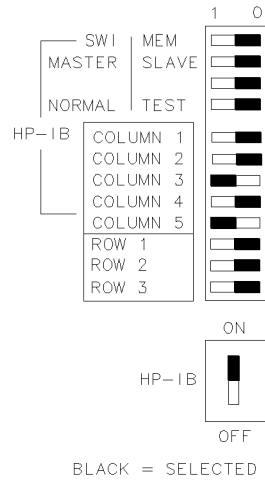

PBB6

**Figure 11-2. Typical HP 70810B Address Switch**



# Index

---

- A** absolute amplitude units, 7-2
- accessories, 10-2
  - shipped with module, 10-2
- active status indicator, 9-3
- ACT status indicator, 9-2
- address
  - soft-set HP-IB, 11-6
  - stand-alone operation, 11-1
- address, binary, 11-4
- addressing
  - for two lightwave sections, 11-1
  - general information for, 11-2
  - HP-IB, 11-2, 11-6
  - HP-MSIB, 11-2
- addressing the module, 11-1
- address map
  - cursor, 9-3
  - to view, 11-8
- address matrix, 11-2, **11-4**
- address protocol, 11-2
- address switches, 11-2, **11-6**
  - column address, 11-6
  - row address, 11-6
- amplitude annotation
  - setting, 7-2
- amplitude units, 8-10
- amplitude values, 8-5
- assignment
  - display window, 11-5
  - keyboard, 11-5
- ASSIGN statements, 4-5
- A status indicator, 9-2
- ATTEN Manual softkey, 7-2
- A UNITS AutoMan softkey, 7-2
- AUNITS command, 4-6
- AUNITS command/query, 8-10
- automatic zeroing, 7-2
- AUTZERO On Off softkey, 7-2

- B** backspace (←), 1-7
- backspace key, 3-6
- blue repair card, 1-12
  
- C** CAL command, 8-11
- CALCOR command/query, 8-12
- calibrate, 8-11
- calibrate optical power menu, 7-2
- calibration, 3-2
- calibration correction factor, 8-12
- calibration corrections, 1-3
- cal opt power softkey, 7-2
- caution symbol, vii
- cleaning fiber-optic connections, 3-9
  - dry connections, 3-9
  - wet connections, 3-10
- cleaning kit, optical connectors, 1-8
- cleaning of optical connectors, 1-8
- CLEAR statements, 4-5
- command sequence, 8-2
- common command parameters, 8-5
  - data byte, 8-5
  - data byte & EOI, 8-5
  - delimiter, 8-5
  - digit, 8-5
  - LF with EOI, 8-5
  - number, 8-5
  - units, 8-6
- communication, lightwave section, 4-3
- connector interface, 1-3
- connector interface, input, 1-8
  
- D** data byte, 8-5
- data byte & EOI, 8-5
- data entry, 3-6
- data receiving, 4-6
- data request, 4-6
- data transfer, 4-6
- dBm softkey, 7-3
- dBm units, 7-3
- default address, 11-1
- delimiter, 8-5
- description
  - HP 70810B Lightwave Section, 1-2
- description of HP 70810B, 1-3
- descriptions
  - error message, 9-6
- digit, 8-5
- display, 11-5
  - communications, 11-5
  - interface, 11-5
- display annotation, 3-3
- display front-panel keys
  - DISPLAY, 3-5



- MENU, 3-5
- USER, 3-5
- Display-Response Area, 11-4
- display status indicators, 9-2
- display units
  - optical, 3-2
- DONE query, 8-13

**E**

- electrostatic discharge, 1-9
  - accessories, 1-9
  - precautions, 1-9
  - protection, 1-9
- enabled active function, 3-6
- enter data via front panel, 3-6
- ENTER statement, 4-7
- ENTER statements, 4-3
- error
  - test internal circuitry, 8-34
  - to return error message, 8-14
- error message reporting, 9-2
- error messages, 9-6-10
- error reporting, 11-5
- ERR query, 8-14
- ERR status indicator, 9-2
- ESD damage reduction, 1-9
- E status indicator, 9-2
- examples of service request, 4-10
- extended error query, 8-36

**F**

- fiber-optic cables
  - cleaning connections, 3-9
- fiber-optic tip, 1-8
- firmware revision
  - return, 8-25
- firmware version, 7-4
- forming a query, 4-6
- frequency values, 8-5
- front-panel
  - features, 3-7
  - LEDs, 3-7
- front-panel connectors
  - OPTICAL INPUT, 3-8
  - OPTICL INPUT, 7-4
  - RF INPUT, 3-8, 7-4
  - RF OUTPUT, 3-8, 7-4
- front-panel indicators
  - LSN, 4-4
  - RMT, 4-4
  - SRQ, 4-4
  - TLK, 4-4
- front-panel interface, 3-5
- fundamental units, 4-6

- H**
  - HD, 8-15
  - hold
    - to blank displays, 8-15
  - HOLD**, 1-7
  - HP 70810A
    - HP-IB address, 4-2
  - HP 70810B
    - calibration corrections, 1-3
    - connector interface, 1-3
    - description, 1-3
    - module installation, 1-5
    - module removal, 1-6
    - optical power meter, 1-3
    - patch cord, 1-3
    - photodetector, 1-3
    - preamplifier, 1-3
    - stand-alone configuration, 1-3
  - HP-IB access area, 11-4
  - HP-IB addressing, 11-2
  - HP-IB address, soft-set, 11-6
  - HP-IB status indicator, 9-2
  - HP-MSIB addressing, 11-2
  - HSWP cable connection, 1-5
  - HSWP IN/OUT connector, 3-8, 7-3
  
- I**
  - ID query, 8-16
  - index-matching compounds, 3-9
  - initial inspection, 1-5
  - initial program considerations, 4-5
  - input connector interface, 1-8
  - input/output characteristics, 5-10
  - input path
    - selection of, 7-3
  - installing the HP 70810B, 1-5
  - instrument preset, 4-5, 8-17
    - commands executed by, 8-17
  - instrument preset key, 3-6
  - interrupt process, 4-8
  - I/O error status indicator, 9-2
  - IP command, 8-17
  
- L**
  - LAMBDA 1300 nm softkey, 7-4
  - LAMBDA 1550 nm softkey, 7-4
  - LAMBDA 850 nm softkey, 7-3
  - LEDs, front-panel, 3-7
  - LF with EOI, 8-5
  - lightwave mode, 3-2, 8-18
    - selecting, 7-3
  - lightwave section
    - communication with remote control, 4-3
    - configurations, 3-2
    - functional testing, 9-5
  - lightwave section description, 1-2
  - lightwave section latch, 3-8, 7-4

- lightwave section status byte, 4-9
- lightwave signal analyzer, 1-2
- local control, 4-4
- LOCAL key, 4-4
- LSN status indicator, 9-2
- LTWAVE command/query, 8-18

**M**

- mainframe/module interconnect, 3-8, 7-4
- maintenance of optical connectors, 1-8
- manual coverage, 1-3
  - errors in the manual, 1-3
  - modified lightwave sections, 1-3
  - serial numbers, 1-3
  - updating, 1-3
- Menu softkeys, 1-6
  - not present, 1-6
- menu structure, 3-5
- message area, 8-35
  - return contents, 8-19
- module accessories, 10-2
- module addressing, 11-1
- module cable connection
  - HSWP, 1-5
- module identification, 8-16
- module operation
  - stand-alone, 1-2
- module options, 10-2
- module specifications, HP 70810B, 5-3
- module troubleshooting, 9-1
- monitoring system operation, 4-8
- monitoring system operation without using service requests, 4-11
- MSG query, 8-19

**N**

- number, 8-5
  - decimal form, 8-5
  - exponential form, 8-5
  - integer form, 8-5

**O**

- operation overview, 3-2
- OPTATN command/query, 8-21
- OPTCOR query, 8-22
- optical
  - attenuator, 3-2
  - display units, 3-2
  - wavelengths, 3-2
- optical attenuator, 8-21
- optical connector
  - cleaning, 1-8
  - cleaning kit, 1-8
  - fiber-optic tip, 1-8
  - interface, 1-8
  - maintenance, 1-8
  - precautions, 1-8
- optical connectors, 1-8

- optical frequency response corrections, 8-22
- optical input, 3-2
- optical input attenuator, 7-2
- OPTICAL INPUT connector, 3-8, 7-4
- optical power, 3-2, 8-24
- optical power meter, 1-3
- optical power meter zeroing, 8-38
- options, 10-2
- OPTPWR query, 8-24
- output revision number, 7-4
- OUTPUT statements, 4-3
- overview
  - softkeys, 3-6

**P**

- panel features
  - ERR LEDs, 3-8
  - front panel, 3-7
  - lightwave section latch, 3-8, 7-4
  - OPTICAL INPUT, 3-8, 7-4
  - rear panel, 3-7
  - RF INPUT, 3-8, 7-4
  - RF OUTPUT, 3-8, 7-4
- patch cord, 1-3, 1-8
- photodetector, 1-3
- power bar, 3-2
- power values, 8-5
- preamplifier, HP 70810B, 1-3
- precautions of optical connectors, 1-8
- problems
  - flashing ERR indicator, 9-2
  - menu softkeys missing, 1-6
- problems; ERR LED on after power-on self test, 1-6
- problems; error message displayed after power-on self test, 1-6
- programming fundamentals, 4-1

**Q**

- query response
  - binary state value, 8-4
  - numeric value, 8-4

**R**

- rear-panel
  - features, 3-7
- rear-panel features
  - HSWP IN/OUT, 3-8, 7-3
  - mainframe/module interconnect, 3-8, 7-4
- reducing ESD damage, 1-9
- remote commands
  - ASSIGN statements, 4-5
  - CLEAR statements, 4-5
  - ENTER statements, 4-3
  - OUTPUT statements, 4-3
  - query, 4-3
  - syntax requirements, 4-4
- remote control, 4-4
- remote setup procedure, 4-2

- removing the HP 70810B, 1-6
- repackaging for service, 1-12
- repair tags, 1-12
- requesting and receiving data, 4-6
- request service conditions, 8-26
- responsivity, 7-4, 8-28
- returning for service, 1-12
- revision number, 7-4
- REV query, 8-25
- RF bypass mode, 3-2
  - to select, 7-3
- RF INPUT, 7-4
- RF INPUT connector, 3-8
- RF OUTPUT connector, 3-8, 7-4
- RMT status indicator, 9-2
- ROM VERSION softkey, 7-4
- RQS command, 8-26
- RSPSVTY query, 8-28
- RSPSVTY softkey, 7-4

**S**

- safety symbols, vii
- sales and service offices, 10-4
- select input softkey, 7-5
- self test, 8-34
- SELF TEST softkey, 7-5
- SER command/query, 8-29
- serial number, 8-29
- serial numbers, 1-3
- service, 1-12
  - foam inserts, 1-12
  - repackaging, 1-12
  - repair tags, 1-12
  - return to factory, 1-12
- service kit, 1-11
  - Service Note 71000A-1, 1-11
- service kit accessories, 10-3
- service menu, 7-5
- service request, 8-30
- service-request mask, 4-9
- service requests, 4-8-11
- service softkey, 7-5
- setup procedure for remote control, 4-2
- shipping, 1-4
  - damage, 1-5
  - packing materials, 1-4
- softkey convention, 3-6
- softkey overview, 3-6
- soft-set address, 11-6
- specifications, 5-1-10
  - general, 5-9
  - HP 70810B Option 850, 5-6
- SRQ command, 8-30
- SRQ status indicator, 9-2
- stand-alone configuration, 1-3

- stand-alone operation address, 11-1
- static-safe accessories, 1-10
- status byte, 8-32
- status indicators, 9-2
  - A, 9-2
  - ACT, 9-2
  - active, 9-3
  - display, 9-2
  - E, 9-2
  - ERR, 9-2
  - HP-IB, 9-2
  - I/O error, 9-2
  - LSN, 9-2
  - RMT, 9-2
  - SRQ, 9-2
  - TLK, 9-2
- STB command, 4-11
- STB query, 8-32
- syntax conventions
  - pictorial notation, 8-2
  - query responses, 8-4
  - syntax summary, 8-3
  - textual notation, 8-2
- syntax requirements, 4-4
- system operation monitoring, 4-8

**T** terminology

- address matrix, 11-2
- address protocol, 11-2
- address switches, 11-2
- characteristics, 5-1
- element, 11-3
- independent, 11-3
- instrument, 11-3
- mainframe, 11-3
- master, 11-3
- module, 11-3
- slave, 11-3
- specifications, 5-1
- stand-alone instrument, 11-3
- sub-master, 11-3

test

- optical attenuator, 7-5
- power meter, 7-5

TEST command, 8-34

TLK status indicator, 9-2

troubleshooting

- catastrophic failures, 9-4
- in stand-alone mode, 9-5
- lightwave section, 9-1
- lightwave signal analyzer, 9-1

- U** units, 8-6
  - dBm, 7-3
  - menu, 7-5
  - Watt, 7-5
- units menu softkey, 7-5
- updating manual, 1-3
- user message, 8-35
- USERMSG command, 8-35
- user power calibration, 7-5
- USR CAL On Off softkey, 7-5
  
- V** value limits
  - amplitude, 8-5
  - frequency, 8-5
  - power, 8-5
  
- W** warm-up time, 3-2
- warning symbol, vii
- WATT softkey, 7-5
- Watt Units, 7-5
- wavelength
  - 1300 nm, 7-4
  - 1550 nm, 7-4
  - 850 nm, 7-3
  
- X** XERR query, 8-36
  
- Z** ZERO command/query, 8-38
- zero (offset compensation), 7-6
- ZERO softkey, 7-6

