

TEST OSCILLATOR

652A

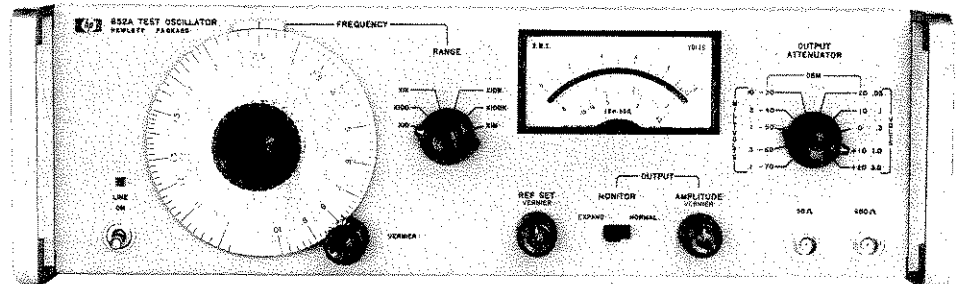

 HEWLETT
PACKARD

OPERATING AND SERVICE MANUAL

MODEL 652A TEST OSCILLATOR

Serials Prefixed: 1226A

Appendix C, Manual Backdating
adapts this manual to the following instruments:
Serial No. 1226A04121 and below.

WARNING

To help minimize the possibility of electrical fire or shock hazards, do not expose this instrument to rain or excess moisture.

Manual Part No. 00652-90006

Microfiche Part No. 00652-90056

©Copyright Hewlett-Packard Company 1966
P.O. Box 301, Loveland, Colorado 80537 U.S.A.



CERTIFICATION

Hewlett-Packard Company certifies that this product met its published specifications at the time of shipment from the factory. Hewlett-Packard further certifies that its calibration measurements are traceable to the United States National Bureau of Standards, to the extent allowed by the Bureau's calibration facility, and to the calibration facilities of other International Standards Organization members.

WARRANTY

This Hewlett-Packard product is warranted against defects in material and workmanship for a period of one year from date of shipment [except that in the case of certain components listed in Section I of this manual, the warranty shall be for the specified period] . During the warranty period, Hewlett-Packard Company will, at its option, either repair or replace products which prove to be defective.

For warranty service or repair, this product must be returned to a service facility designated by -hp-. Buyer shall prepay shipping charges to -hp- and -hp- shall pay shipping charges to return the product to Buyer. However, Buyer shall pay all shipping charges, duties, and taxes for products returned to -hp- from another country.

Hewlett-Packard warrants that its software and firmware designated by -hp- for use with an instrument will execute its programming instructions when properly installed on that instrument. Hewlett-Packard does not warrant that the operation of the instrument, or software, or firmware will be uninterrupted or error free.

LIMITATION OF WARRANTY

The foregoing warranty shall not apply to defects resulting from improper or inadequate maintenance by Buyer, Buyer-supplied software or interfacing, unauthorized modification or misuse, operation outside of the environmental specifications for the product, or improper site preparation or maintenance.

NO OTHER WARRANTY IS EXPRESSED OR IMPLIED. HEWLETT-PACKARD SPECIFICALLY DISCLAIMS THE IMPLIED WARRANTIES OF MERCHANTABILITY AND FITNESS FOR A PARTICULAR PURPOSE.

EXCLUSIVE REMEDIES

THE REMEDIES PROVIDED HEREIN ARE BUYER'S SOLE AND EXCLUSIVE REMEDIES. HEWLETT-PACKARD SHALL NOT BE LIABLE FOR ANY DIRECT, INDIRECT, SPECIAL, INCIDENTAL, OR CONSEQUENTIAL DAMAGES, WHETHER BASED ON CONTRACT, TORT, OR ANY OTHER LEGAL THEORY.

ASSISTANCE

Product maintenance agreements and other customer assistance agreements are available for Hewlett-Packard products.

For any assistance, contact your nearest Hewlett-Packard Sales and Service Office. Addresses are provided at the back of this manual.

TABLE OF CONTENTS

Section	Page
1-1. Description	1-1
1-6. Accessory Features	1-1
1-8. Instrument Identification	1-1

Section	Page
II. INSTALLATION	2-1
2-1. Introduction	2-1
2-3. Initial Inspection	2-1
2-5. Power Requirements	2-1
2-7. Power Cords	2-1
2-9. Grounding Requirements	2-1
2-11. Installation	2-1
2-13. Rack/Bench Installation	2-1
2-15. Repackaging for Shipment	2-1

Section	Page
III. OPERATING INSTRUCTIONS	3-1
3-1. Introduction	3-1
3-3. Controls and Indicators	3-1
3-5. Adjustment of Mechanical Zero	3-1
3-7. Operation	3-1

Section	Page
IV. THEORY OF OPERATION	4-1
4-1. General Description	4-1
4-3. Circuit Description	4-1
4-5. Oscillator Circuit	4-1
4-13. Automatic Gain Control	4-2
4-15. Power Amplifier	4-2
4-17. Normal Monitor Circuit	4-2
4-19. Expand Monitor Circuit	4-2
4-26. Output Attenuator	4-3
4-29. Regulated Power Supply	4-3

Section	Page
V. MAINTENANCE	5-1
5-1. Introduction	5-1
5-3. Required Test Equipment	5-1
5-5. Performance Tests	5-1
5-7. Frequency Range Test	5-1
5-8. Dial Accuracy Test	5-1
5-9. Output Tests	5-2
5-14. Output Monitor Accuracy Test	5-5
5-15. Attenuator Test	5-5
5-16. Amplitude Control Test	5-6
5-17. Distortion Test	5-6

Section	Page
5-18. Hum and Noise Test (Optional)	5-7
5-19. Amplitude Stability Test (Optional)	5-7
5-20. Output Impedance Test	5-8
5-21. Adjustment and Calibration Procedure	5-8
5-23. Cover Removal	5-8
5-26. Power Supply Voltage Adjustments	5-8
5-27. Frequency Calibration Procedures	5-8
5-28. Preliminary Distortion Adjustment	5-10
5-29. Frequency Dial Calibration	5-11
5-30. X1K Range Adjustments	5-11
5-31. X100 and X10K Range Frequency Calibration	5-12
5-32. X10 Range Frequency Calibration	5-12
5-33. X1M Range Frequency Calibration	5-12
5-34. X100K Range Frequency Calibration	5-13
5-35. 10 MHz Flatness Adjustment	5-13
5-36. Output Adjustments	5-14
5-40. Normal Monitor Calibration	5-14
5-41. Expanded Monitor Calibration	5-15
5-44. After Calibration	5-16
5-46. Troubleshooting Procedure	5-16
5-51. Troubleshooting Information	5-17
5-53. Troubleshooting the Oscillator Circuit	5-18
5-56. Troubleshooting the Power Amplifier	5-19
5-57. Troubleshooting the Attenuator	5-19
5-58. Servicing Etched Circuit Boards	5-20
5-60. Servicing Rotary Switches	5-20
5-62. Servicing Tuner Assembly	5-20

Section	Page
VI. CIRCUIT DIAGRAMS	6-1/6-2
6-1. Introduction	6-1/6-2

Section	Page
VII. REPLACEABLE PARTS	7-1
7-1. Introduction	7-1
7-4. Ordering Information	7-1
7-6. Non-Listed Parts	7-1

APPENDICES

- A. CODE LIST OF MANUFACTURERS
- B. SALES AND SERVICE OFFICES
- C. MANUAL BACKDATING CHANGES

LIST OF ILLUSTRATIONS

Figure	Page	Figure	Page
1-1.	Model 652A Test Oscillator	1-0	
3-1.	Location and Description of Controls and Indicators	3-2	
3-2.	Impedance Correction Graph.	3-3	
4-1.	RC Network Characteristics.	4-1	
4-2.	Regulated Power Supply Output Voltage vs. Current	4-3	
4-3.	Simplified Schematic of Current Limiting Circuitry	4-3	
5-1.	Frequency Tests	5-1	
5-2.	Output Tests	5-2	
5-3.	Flatness Tests	5-3	
5-4.	Attenuator Test	5-5	
5-5.	Distortion Test	5-6	
5-6.	Amplitude Stability Test.	5-7	
		5-7.	Location of Internal Adjustments.
		5-8.	Frequency Calibration
		5-9.	10 kHz Monitor Calibration.
		5-10.	Alignment Access Covers for Models 651B, 2A, 3A, 4A.
		5-11.	Troubleshooting Tree.
		6-1.	Block Diagram
		6-2.	Oscillator Circuit.
		6-3.	Normal and Expand Monitor Circuits . .
		6-4.	Power Supply
		7-1.	Frequency Tuning Assembly (Mechanical Parts).
		7-2.	Chassis Components (Mechanical Parts).

LIST OF TABLES

Table	Page	Table	Page
1-1.	Specifications	5-4.	Flatness Test Settings and Limits
5-1.	Required Test Equipment	5-5.	Distortion Test
5-2.	Dial Accuracy Test	5-6.	Frequency Calibration Components
5-3.	Typical Thermal Converter Input/Output Change.	5-7.	Frequency Dial Accuracy Calibration
		5-8.	Front Panel Troubleshooting Tests
		7-1.	Replaceable Parts



SAFETY SUMMARY

The following general safety precautions must be observed during all phases of operation, service, and repair of this instrument. Failure to comply with these precautions or with specific warnings elsewhere in this manual violates safety standards of design, manufacture, and intended use of the instrument. Hewlett-Packard Company assumes no liability for the customer's failure to comply with these requirements. This is a Safety Class 1 instrument.

GROUND THE INSTRUMENT

To minimize shock hazard, the instrument chassis and cabinet must be connected to an electrical ground. The instrument is equipped with a three-conductor ac power cable. The power cable must either be plugged into an approved three-contact electrical outlet or used with a three-contact to two-contact adapter with the grounding wire (green) firmly connected to an electrical ground (safety ground) at the power outlet. The power jack and mating plug of the power cable meet International Electrotechnical Commission (IEC) safety standards.

DO NOT OPERATE IN AN EXPLOSIVE ATMOSPHERE

Do not operate the instrument in the presence of flammable gases or fumes. Operation of any electrical instrument in such an environment constitutes a definite safety hazard.

KEEP AWAY FROM LIVE CIRCUITS

Operating personnel must not remove instrument covers. Component replacement and internal adjustments must be made by qualified maintenance personnel. Do not replace components with power cable connected. Under certain conditions, dangerous voltages may exist even with the power cable removed. To avoid injuries, always disconnect power and discharge circuits before touching them.

DO NOT SERVICE OR ADJUST ALONE

Do not attempt internal service or adjustment unless another person, capable of rendering first aid and resuscitation, is present.

DO NOT SUBSTITUTE PARTS OR MODIFY INSTRUMENT

Because of the danger of introducing additional hazards, do not install substitute parts or perform any unauthorized modification to the instrument. Return the instrument to a Hewlett-Packard Sales and Service Office for service and repair to ensure that safety features are maintained.

DANGEROUS PROCEDURE WARNINGS

Warnings, such as the example below, precede potentially dangerous procedures throughout this manual. Instructions contained in the warnings must be followed.

WARNING

Dangerous voltages, capable of causing death, are present in this instrument. Use extreme caution when handling, testing, and adjusting.

SAFETY SYMBOLS

General Definitions of Safety Symbols Used On Equipment or In Manuals.



Instruction manual symbol: the product will be marked with this symbol when it is necessary for the user to refer to the instruction manual in order to protect against damage to the instrument.



Indicates dangerous voltage (terminals fed from the interior by voltage exceeding 1000 volts must be so marked).

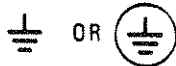

Protective conductor terminal. For protection against electrical shock in case of a fault. Used with field wiring terminals to indicate the terminal which must be connected to ground before operating equipment.



Low-noise or noiseless, clean ground (earth) terminal. Used for a signal common, as well as providing protection against electrical shock in case of a fault. A terminal marked with this symbol must be connected to ground in the manner described in the installation (operating) manual, and before operating the equipment.

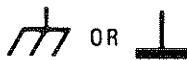

Frame or chassis terminal. A connection to the frame (chassis) of the equipment which normally includes all exposed metal structures.



Alternating current (power line).



Direct current (power line).



Alternating or direct current (power line).

WARNING

The **WARNING** sign denotes a hazard. It calls attention to a procedure, practice, condition or the like, which, if not correctly performed or adhered to, could result in injury or death to personnel.

CAUTION

The **CAUTION** sign denotes a hazard. It calls attention to an operating procedure, practice, condition or the like, which, if not correctly performed or adhered to, could result in damage to or destruction of part or all of the product.

NOTE :

The **NOTE** sign denotes important information. It calls attention to procedure, practice, condition or the like, which is essential to highlight.

SECTION I

GENERAL INFORMATION

1-1. DESCRIPTION.

1-2. The Hewlett-Packard Model 652A Test Oscillator is a highly stable, capacitance-tuned oscillator that has a frequency range of 10 Hz to 10 MHz. The oscillator has a sine-wave output that is adjustable from 10 microvolts to 3.16 volts into 50 or 600 ohms. The Model 652A Test Oscillator is shown in Figure 1-1, and the specifications are given in Table 1-1.

1-3. Two output impedances are provided at the front panel output connectors. The 600 ohm connector provides an output with an impedance that is compatible with transmission lines and many distribution systems. The 50 ohm connector provides an output for circuits needing a low source impedance.

1-4. The Model 652A Test Oscillator output voltage is constantly monitored at the input to the attenuator by an internal voltmeter. The voltmeter has two scales for RMS voltage readings, and a dBm scale referenced to 1 milliwatt into 50 ohms. The meter scale can be expanded and used to set and maintain a reference for the output voltage, when the MONITOR switch is in the EXPAND position. The 1.0 volt scale is shaded from 0.9 to 1.0 to denote the expandable area. Other voltages can be obtained using the OUTPUT ATTENUATOR and, if desired, an external 1 dB attenuator.

1-5. The OUTPUT ATTENUATOR, in conjunction with the AMPLITUDE control, allows any output voltage from 10

microvolts to 3.16 volts to be selected, when matched into a 50 or 600 ohm load.

1-6. ACCESSORY FEATURES.

1-7. The accessory furnished with the Model 652A is the -hp- Model 11048C Feedthrough Termination. It is used to insure that the Test Oscillator is operating into the rated impedance, in the event that the instrument is connected to a device with an impedance greater than 50 ohms. The specifications for the Model 11048C Feedthrough Termination are listed below:

Terminating Resistance - 50 ohms +/- 0.25%
Connectors - BNC male on one end, and BNC female on the other end.

1-8. INSTRUMENT AND MANUAL IDENTIFICATION.

1-9. Hewlett-Packard uses a two-section serial number. The first section (prefix) identifies a series of instruments. The last section (suffix) identifies a particular instrument within the series. If a letter is included with the serial number, it identifies the country in which the instrument was manufactured. If the serial prefix of your instrument differs from the one on the title page of this manual, a change sheet will be supplied to make this manual compatible with newer instruments or the backdating information in Appendix C will adapt this manual to earlier instruments. All correspondence with Hewlett-Packard should include the complete serial number.

Table 1-1. Specifications

<p>Frequency Range: 10 Hz to 10 MHz, 6 bands, dial calibrations: 1 to 10.</p> <p>Dial Accuracy: (including warm-up drift and +/- 10% line voltage variation) +/- 2% 100 Hz (on X100 Range) to 1 MHz (on X100K Range) +/- 3% 10 Hz to 100 Hz and 1 MHz to 10 MHz.</p> <p>Output: Maximum: 3.16V into 50 or 600 ohms 6.32V open circuit +23 dBm into 50 ohms Ranges: 0.1 mV to 3.16V full scale, 10 steps in 1, 3, 10 sequence, coarse and fine adjustable. -70 dBm to +23 dBm (50 ohm output) full scale, 10 dBm per step, coarse and fine adjustable. Flatness (Amplitude not readjusted to a reference on the output monitor): +/- 2% 100 Hz (on X100 range) to 1 MHz +/- 3% 10 Hz to 100 Hz +/- 4% 1 MHz to 10 MHz*</p> <p>Flatness (Amplitude readjusted to a reference on the output monitor):</p> <table border="1" style="width: 100%; text-align: center;"> <thead> <tr> <th rowspan="2">Range</th> <th colspan="4">Frequency</th> </tr> <tr> <th>10 Hz</th> <th>20 Hz</th> <th>4 MHz</th> <th>10 MHz</th> </tr> </thead> <tbody> <tr> <td>3V and 1V</td> <td>2%</td> <td>1%</td> <td>2%</td> <td></td> </tr> <tr> <td>.3V to .3 mV</td> <td>2.5%</td> <td>1.5%</td> <td>2.5%</td> <td></td> </tr> <tr> <td>.1 mV</td> <td>3%</td> <td>2%</td> <td>3%</td> <td></td> </tr> </tbody> </table> <p>*This specification applies only at 50 ohm output. The response above 1 MHz at the 600 ohm output is affected by capacitive loads.</p>	Range	Frequency				10 Hz	20 Hz	4 MHz	10 MHz	3V and 1V	2%	1%	2%		.3V to .3 mV	2.5%	1.5%	2.5%		.1 mV	3%	2%	3%		<p>Flatness (Amplitude readjusted using expanded scale on output monitor): +/- 0.25% 3V and 1V ranges +/- 0.75% .3V to .3 mV range +/- 1.75% .1 mV range</p> <p>Distortion: less than 1% 10Hz to 2 MHz less than 2% at 2 MHz to 5 MHz less than 4% 5 MHz to 10 MHz</p> <p>Hum and Noise: less than 0.05% of maximum rated output between 10 Hz and 10 MHz.</p> <p>Output Monitor: Accuracy: +/- 2% of full scale. Voltmeter monitors level at input of attenuator in volts or dB. Top scale calibrated in volts; bottom scale in dB. Expand scale: expands reference voltage of the Normal scale from 0.9 to 1.0 or 2.8 to 3.2.</p> <p>Attenuator: Range: 90 dB in 10 dB steps. Overall Accuracy: +/- 0.075 dB, -60 dBm to 20 dBm +/- 0.2 dB, -70 dBm to -60 dBm</p> <p>Amplitude Control: 20 dB range: coarse and fine.</p> <p>Amplitude Stability: +/- 2% per mo., 20° C to 30° C</p> <p>Temperature Range: 0° C to + 50° C.</p> <p>Power Requirements: 115V or 230V +/- 10%, 30 W, 48 Hz to 66 Hz.</p>
Range		Frequency																							
	10 Hz	20 Hz	4 MHz	10 MHz																					
3V and 1V	2%	1%	2%																						
.3V to .3 mV	2.5%	1.5%	2.5%																						
.1 mV	3%	2%	3%																						

115 V ± 10%, 48 to 440 Hz, OR 230 V ± 10% 48 to 66 Hz, 30 VA NOMINAL, 35 VA MAXIMUM.

2.6 THE MODEL 652A WILL OPERATE FROM A POWER SOURCE OF 115V ± 10%, 48 TO 440 Hz, OR 230V ± 10%, 48 TO 66 Hz. LINE VOLTAGE SELECTION IS MADE BY SETTING THE REAR PANEL LINE SELECTOR SWITCH. A 0.4 AMPERE SLOW-BLOW FUSE IS USED FOR BOTH 115V AND 230V OPERATION.

CHANGES PER HP SUPPLEMENT A, DATED 23 NOV 79
(27 DEC 82 - DMK)

SECTION II

INSTALLATION

2-1. INTRODUCTION.

2-2. This section contains information and instructions necessary for installing and shipping the Model 652A Test Oscillator. Included are initial inspection procedures, power and grounding requirements, environmental information, installation instructions and instructions for repackaging for shipment.

2-3. INITIAL INSPECTION.

2-4. This instrument was carefully inspected both mechanically and electrically before shipment. It should be free of marks or scratches and in perfect electrical order upon receipt. To confirm this, the instrument should be inspected for physical damage incurred in transit. If the instrument was damaged in transit, file a claim with the carrier. Check for supplied accessories (Paragraph 1-6) and test the electrical performance using the Performance Tests given in Section V. If there is damage or deficiency, see the warranty in the front of this manual.

2-5. POWER REQUIREMENTS.

~~2-6. The Model 652A will operate from either 115 or 230 volts ac, 48 - 66 Hz. The instrument can be easily converted from 115 to 230 volt operation by changing the position of the slide switch located on rear panel, so that the designation appearing on the switch matches the nominal voltage of the power source. A 0.4 ampere, slow-blow fuse is used for 115 and 230 volt operation.~~

2-7. Power Cords.

2-8. Figure 2-1 illustrates the standard power plug configurations that are used throughout the United States and in other countries. The -hp- part number directly below each

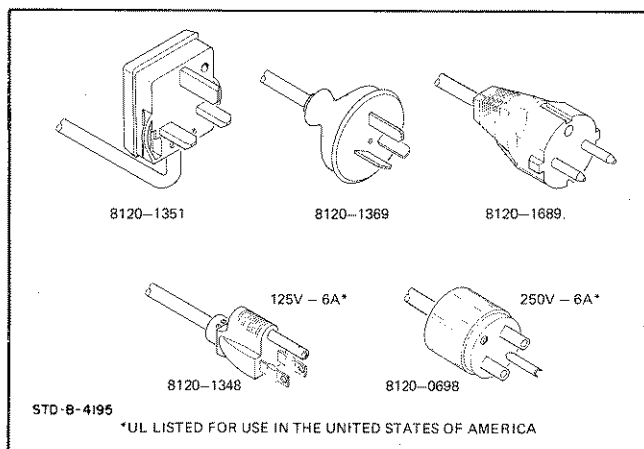

Figure 2-1. Power Cords.

drawing is the part number for a 652A power cord equipped with a power plug of that configuration. If the appropriate power cord is not included with the instrument, notify the nearest -hp- Sales and Service Office and a replacement cord will be provided.

2-9. GROUNDING REQUIREMENTS.

2-10. To protect operating personnel, the National Electrical Manufacturer's Association (NEMA) recommends that the instrument panel and cabinet be grounded. The Model 652A is equipped with a three-conductor power cord which, when plugged into an appropriate receptacle, grounds the instrument. The offset pin on the power plug is the ground connection.

2-11. INSTALLATION.

2-12. The -hp- Model 652A is fully transistorized; therefore, no special cooling is required. However, the instrument should not be operated where the ambient temperature exceeds 50° C (122° F).

2-13. RACK/BENCH INSTALLATION.

2-14. The Model 652A is initially shipped as a bench-type instrument (unless ordered specifically as a rack type) with plastic feet and a tilt stand in place. Conversion to a rack-mounted instrument can be accomplished by using the rack mounting kit and instructions furnished with your instrument. HP PART NUMBER 5060-8740.

2-15. REPACKAGING FOR SHIPMENT.

2-16. The following is a general guide for repackaging for shipment. If you have any questions, contact your local -hp- Sales and Service Office. (See Appendix B for office locations.)

NOTE

If the instrument is to be shipped to Hewlett-Packard for service or repair, attach a tag to the instrument identifying the owner and indicating the service or repair to be accomplished, include the model number and full serial number of the instrument. In any correspondence, identify the instrument by model number, serial number and serial number prefix.

a. Place instrument in original container if available. If original container is not available, a suitable one can be purchased from your nearest -hp- Sales and Service Office.

If original container is not used,

b. Wrap instrument in heavy paper or plastic before placing in an inner container.

c. Use plenty of packing material around all sides of instrument and protect panel faces with cardboard strips.

d. Place instrument and inner container in a heavy carton or wooden box and seal with strong tape or metal bands.

e. Mark shipping container with "Delicate Instrument," "Fragile," etc.

SECTION III

OPERATING INSTRUCTIONS

3-1. INTRODUCTION.

3-2. The Model 652A Test Oscillator generates a stable sine wave output that is available at output impedance levels of 600 ohms and 50 ohms. The frequency of the output is variable from 10 Hz to 10 MHz. The output power level can be varied from 10 microvolts to 3.16 volts into 600 or 50 ohm loads. The output monitor may be used as a voltmeter to monitor the amplitude of the output, or it may be used to establish a reference level for the output.

3-3. CONTROLS AND INDICATORS.

3-4. Figure 3-1 identifies and describes the function of all the front and rear panel controls, connectors, and indicators on the Model 652A.

3-5. ADJUSTMENT OF MECHANICAL ZERO.

3-6. The output monitor is properly zero-set when the meter pointer rests over the zero mark, and the Test Oscillator is in normal operating position at normal operating temperature, and is turned off. Zero-set the output monitor as follows to obtain maximum accuracy and mechanical stability.

- a. Turn Test Oscillator on and allow it to operate for at least 20 minutes, to let the meter movement reach normal operating temperature.
- b. Turn Test Oscillator off, and allow 30 seconds for all capacitors to discharge.
- c. Insert pointed object (such as tip of ball-point pen) into recess on adjustment wheel, and rotate wheel until meter pointer is exactly over zero.

3-7. OPERATION.

3-8. To operate the 652A Test Oscillator, proceed as follows:

- a. Set the slide switch (S5) to the proper line voltage (115 V or 230 V at 48 – 66 Hz), and connect the selected primary power to the Test Oscillator.
- b. Turn LINE ON switch to On position. Indicator lamp will glow, verifying application of primary power.
- c. Set FREQUENCY RANGE switch and FREQUENCY Dial to desired output frequency.
- d. Set OUTPUT ATTENUATOR switch to desired voltage range.

- e. Connect load to output connector having an impedance which matches impedance of load.
- f. Place MONITOR switch in NORMAL position, and adjust AMPLITUDE controls for desired output voltage, as indicated on the output monitor.
- g. The output monitor, M1, indicates the rms value of the output voltage, and the power level in dBm for resistive loads of 50 ohms. The output voltage level is obtained by multiplying the monitor scale reading by the monitor scale multiplier which appears on the OUTPUT ATTENUATOR switch. Use the following equation and the impedance correction graph of Figure 3-2 to obtain the Model 652A output power level in dBm, for loads other than those marked on the output connectors.

$$\text{Output Voltage} = \frac{R_L}{R_L + R_S} \times 2V_m$$

Where,

R_L = Load Resistance (Terminating Resistance)

R_S = Source Resistance (Output Impedance of Oscillator)

V_m = Model 652A Output Monitor voltage indication multiplied by the output attenuator voltage setting.

Problem: A 600 ohm load is placed on the 50 ohm output connector. The Model 652A output monitor indicates an output of 0.9 volts, with the OUTPUT ATTENUATOR set on the 1.0 volt (+10 dBm) range. Find the actual output voltage and power level (in dBm) of the Model 652A.

Solution: The actual output voltage is calculated as follows:

$$\text{Output Voltage} = \frac{600}{600 + 50} \times 2(0.9) = 1.66 \text{ volts}$$

If the monitor were to indicate this 1.66 volts, then the power level indicated would be +17.3 dBm (on the +20 dBm range). The actual power level, however, in the 600 ohm load is the algebraic sum of this theoretically indicated power (+17.3 dBm) and a correction factor. The correction factor is obtained from the impedance graph of Figure 3-2; for this example, using a 600 ohm load, it would be -10.8 dBm. The actual power level in the 600 ohm load, then, is +6.5 dBm [17.3 dBm + (-10.8 dBm)]

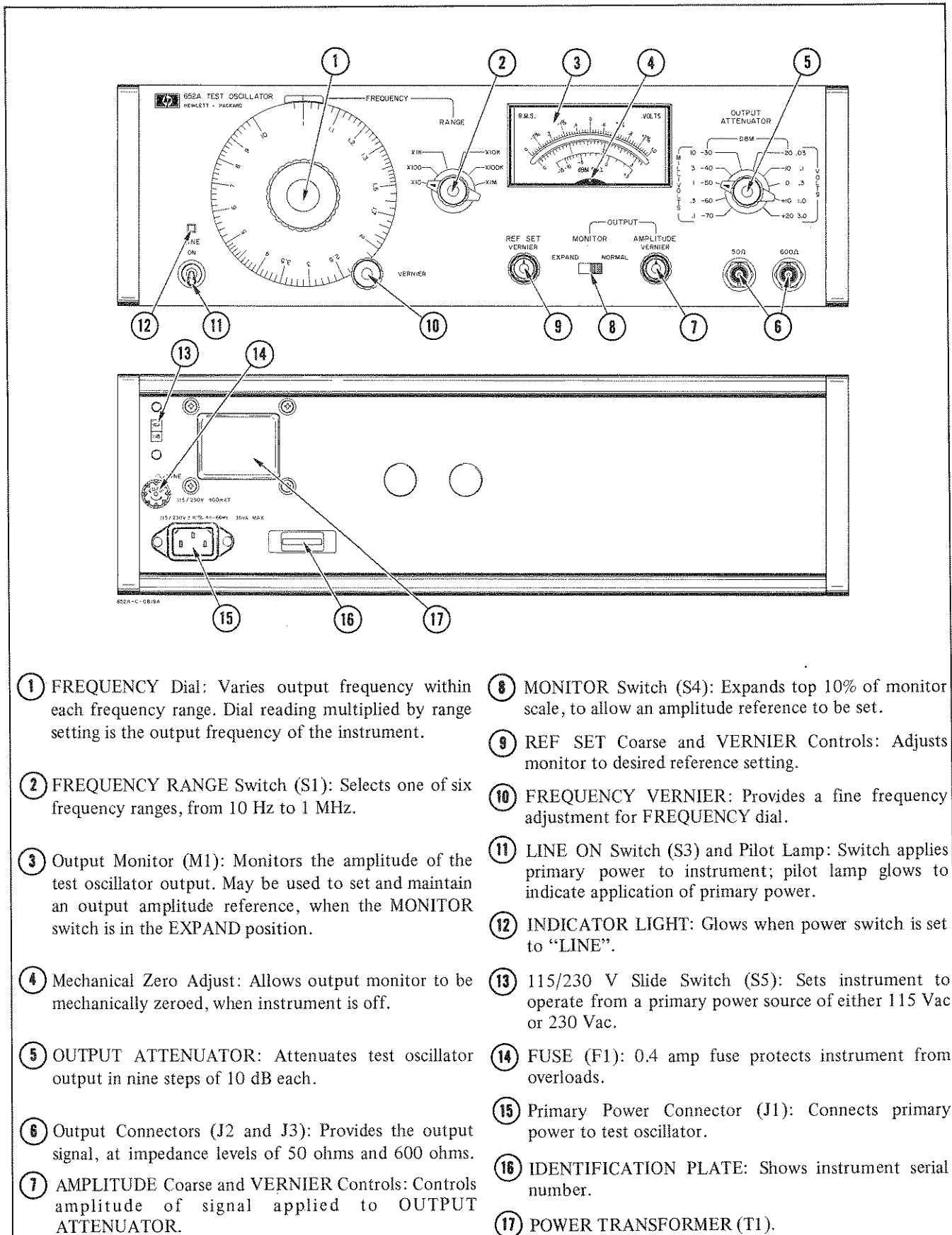
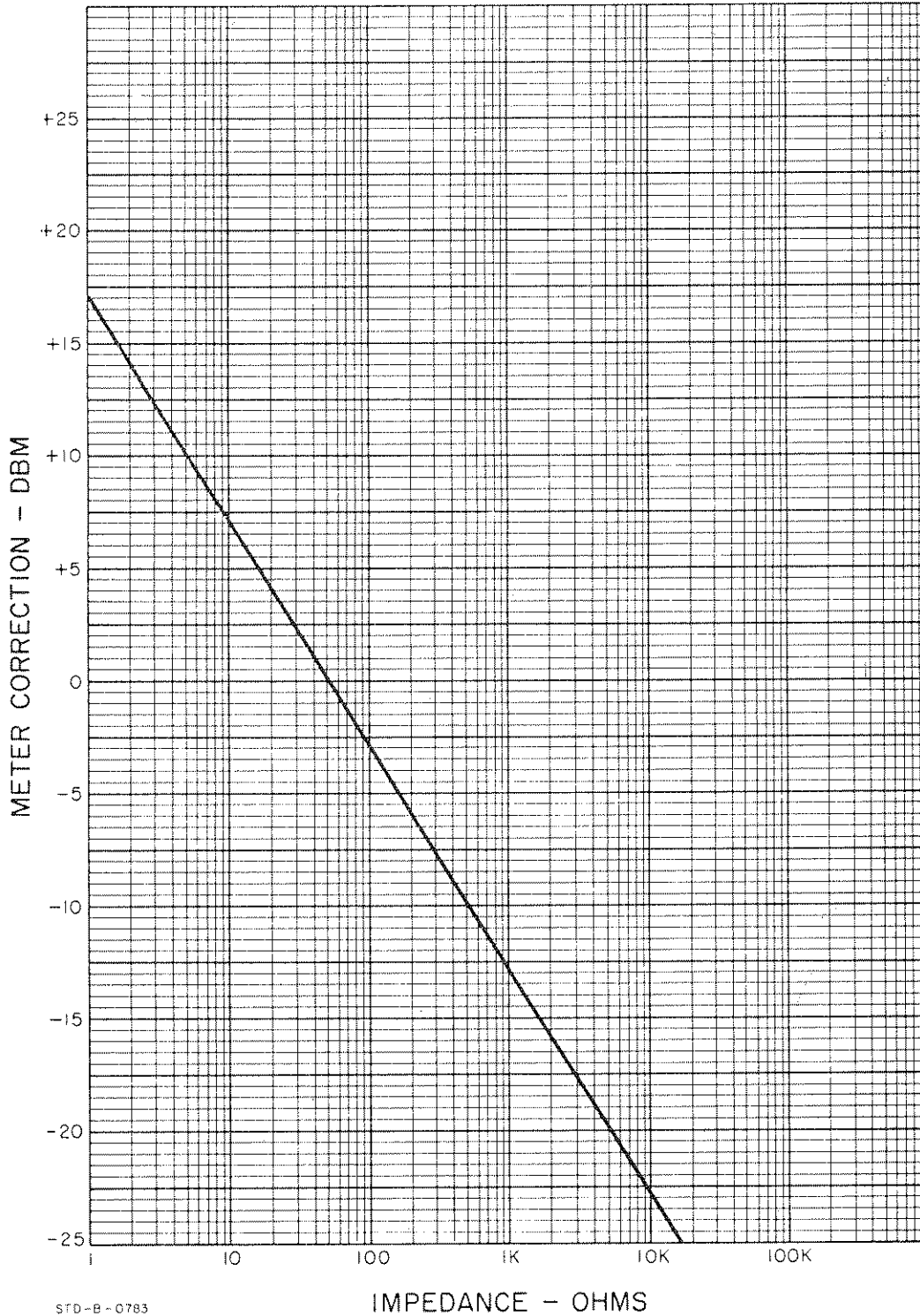

Figure 3-1. Location and Description of Controls and Indicators

NOTE

To use the EXPAND function of the Model 652A perform steps h through j. To obtain a reference on the output monitor the monitor indication must be in the top 10% of scale. If not, the REF SET controls will not have sufficient range to establish a reference.

- h. Set MONITOR switch to EXPAND position.
- i. Adjust REF SET controls until desired reference is indicated on the percent scale of the output monitor.
- j. Use AMPLITUDE controls to maintain set reference whenever frequency of oscillator is changed.



STD-B-0783

Figure 3-2. Impedance Correction Graph

SECTION IV

THEORY OF OPERATION

4-1. GENERAL DESCRIPTION.

4-2. The Model 652A Test Oscillator includes an oscillator, power amplifier, peak detector, attenuator, normal monitor circuit and expand monitor circuit. A block diagram of the instrument is shown in Figure 6-1. The oscillator circuit uses a modified Wien bridge network to generate a stable, distortionless sine wave signal which is applied to the power amplifier circuit. The automatic gain control utilizes a feedback voltage from a peak detector to the oscillator circuit to stabilize the output signal. The power amplifier circuit is used to increase the output power available at the 50-ohm and 600-ohm output connectors and to improve the frequency stability of the output signal with changing output loads. The output attenuator provides a means of attenuating the signal at the output connectors in nine steps of 10 dB each. The normal monitor circuit monitors the signal level at the input to the attenuator. The expand monitor circuit allows the top 10% of the monitor scale to be expanded, so that a reference can be set. The regulated power supply provides all voltages required by the 652A circuits.

4-3. CIRCUIT DESCRIPTION.

4-4. Refer to Figures 6-2 thru 6-4 for the following discussion.

4-5. OSCILLATOR CIRCUIT.

4-6. The oscillator circuit generates a sinusoidal signal at the frequency selected by the RANGE switch and FREQUENCY Dial located on the front panel. The RC bridge network is a modified Wien bridge circuit, consisting of an RC frequency selective network and a resistive voltage divider network. The Wien bridge in the Model 652A Test Oscillator differs from the conventional Wien bridge circuit in the design of the resistive voltage divider network. The resistor in the conventional Wien bridge is replaced with a variable impedance (Z_1 on Figure 6-1) consisting of A2CR6 and A2CR7.

4-7. Oscillation at the selected frequency is made possible by the use of both positive and negative feedback. Positive feedback is provided through a frequency sensitive RC network to the differential amplifier A2Q2 and A2Q3; negative feedback is provided to the differential amplifier through a network insensitive to frequency. Only at the selected frequency will the positive feedback exceed the negative feedback voltage to sustain oscillation.

4-8. The RANGE switch, S1, selects combinations of resistors and capacitors (S1R1 through S1R24, and S1C1 through S1C15) to establish the frequency sensitive RC networks for the six frequency ranges of the Test Oscillator.

The FREQUENCY Dial varies the main frequency tuning elements C1A, C1B, and C1C. The RC components maintain the proper phase relationship of the positive feedback voltage. At frequencies where $X_C = R$, the positive feedback voltage is in phase with the oscillator output voltage (refer to Figure 4-1) and exceeds the negative feedback voltage. At frequencies other than where $X_C = R$, the positive feedback voltage is neither of the right phase nor of sufficient amplitude to maintain oscillations.

4-9. The impedance converter transistor, A2Q1, provides a high impedance in series with the input impedance of the differential amplifier on the first four frequency ranges (X10 - X10K). The high impedance added prevents the RC bridge circuit from being loaded by the low input impedance of the differential amplifier, A2Q2 and A2Q3, on the lower frequency ranges. The impedance converter is bypassed on the X100K and X1M ranges due to lower resistor values in the RC bridge.

4-10. The difference between the feedback voltages from the bridge circuit is amplified by differential amplifier A2Q2 and A2Q3, and is applied to the complementary symmetry circuit A2Q5 and A2Q6, through emitter follower A2Q4. A positive feedback voltage from the output of the complementary symmetry circuit is applied between resistors A2R8 and A2R9, in the collector circuit of A2Q2, on the first four frequency ranges. The application of the feedback voltage at this point is used to make the effective resistance of the collector load higher than the input impedance of the emitter follower A2Q4, forcing the collector current into the base of the emitter follower. The increase in the signal level results in an increase in the loop gain of the oscillator circuit. The feedback voltage is removed on the X100K and X1M

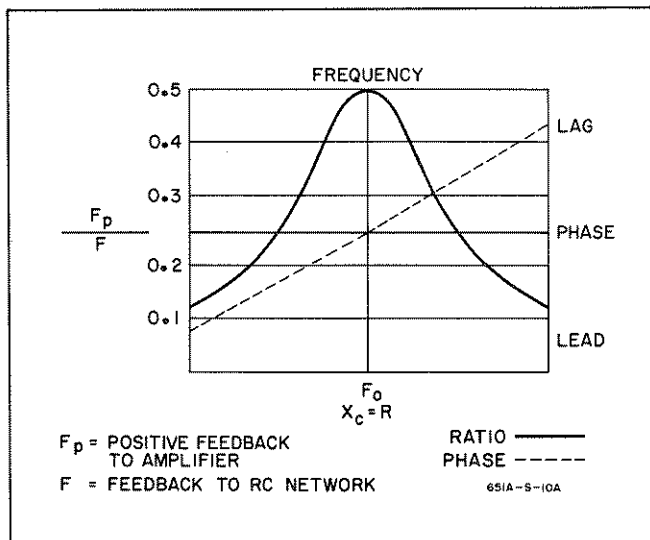

Figure 4-1. RC Network Characteristics

frequency range due to the value of resistors A2R8 and A2R9 exceeding the input impedance of the emitter follower at the higher frequencies.

4-11. The complementary symmetry circuit is used to provide power gain and to increase the dynamic voltage range of the oscillator; also, the low output impedance of the complementary symmetry circuit prevents the oscillator output circuit from being loaded by the RC bridge. The complementary symmetry circuit transistors are forward-biased by diodes A2CR2, A2CR3, and A2CR4, and with no signal applied, are conducting slightly to reduce cross-over distortion in the output signal.

4-12. The output of the oscillator circuit drives the power amplifier with a constant voltage set by the AMPLITUDE coarse and VERNIER controls, R2A and R2B. The voltage level applied to the power amplifier is held constant by the action of the peak detector circuit.

4-13. AUTOMATIC GAIN CONTROL.

4-14. The output of the oscillator circuit is superimposed on a negative reference bias at the base of A2Q7. This bias voltage is determined by the setting of the amplitude controls. The peak detector, A2Q7, will conduct only on the positive peaks when the negative bias is overcome. The average dc voltage across A2C7, A2C8, A2C9 and A2C10 biases the diodes A2CR6 and A2CR7 to determine the impedance of the negative feedback side of the Wien bridge. Thus the amplitude of the oscillations is automatically controlled. A2CR5 and A2CR9 provide temperature compensation for the bias voltage on A2Q7, and A2CR8 prevents the reverse breakdown of A2Q7. A2R17 is adjustable to compensate for differences in the operating characteristics of diodes A2CR6 and A2CR7, minimizing distortion in the negative feedback and subsequently in the oscillator output.

4-15. POWER AMPLIFIER.

4-16. The power amplifier circuit increases the power gain of the signal received from the oscillator circuit. The operation of the differential amplifier A2Q8 and A2Q9, emitter follower A2Q10, and complementary symmetry circuit A2Q11 and A2Q12 is similar to the corresponding stages in the oscillator circuit. The negative feedback voltage from the output of the complementary symmetry circuit is applied to the differential amplifier at a fixed level to stabilize the power amplifier output signal. The power amplifier output is continuously monitored by one of the two monitor circuits before the signal is applied to the output attenuator circuit.

4-17. NORMAL MONITOR CIRCUIT.

4-18. The normal monitor circuit monitors the signal level applied to the output attenuator circuit and provides a signal to the output monitor, M1, when the MONITOR switch, S4, is in the NORMAL position. The amplifier A1Q9 serves both

as an impedance converter between the monitor circuit and the power amplifier output circuit and as a current source to provide full-scale monitor indications. The high input impedance of the amplifier prevents the power amplifier from being loaded with the low impedance of the output monitor, M1. The emitter follower A1Q8 provides a positive feedback voltage which is applied between resistors A1R18 and A1R19, in the collector lead of amplifier A1Q9. The application of the feedback voltage at this point is used to increase the effective resistance of the collector circuit, which results in the amplifier A1Q9 appearing as a high impedance current source to the monitor. The diode A1CR10 provides a small amount of forward bias to rectifier diodes A1CR8 and A1CR9, which keeps the diodes out of the non-linear region, thus increasing monitor accuracy at one-tenth full-scale readings. The 10 MHz adjustment, A1C15, compensates for small variations in circuit capacitance so the monitor will have a flat frequency response. The monitor calibration resistor, A1R23, provides an additional calibration adjustment which is made at 400 Hz.

4-19. EXPAND MONITOR CIRCUIT.

4-20. The expand monitor circuit allows the top 10% of the output monitor scale to be expanded to full scale. A reference may then be set on the scale, and deviations up to $\pm 2.5\%$ in the oscillator output will be indicated on the monitor. The circuit is comprised of an average detector, a differential amplifier, and a variable reference supply. The difference between the outputs of the detector and the reference supply is amplified by the differential amplifier, and is applied to the monitor, M1, when the MONITOR switch, S4, is in the EXPAND position. The dc output of the detector is proportional to the amplitude of the oscillator output, and the amplitude of the reference supply output may be varied by the REF SET coarse and VERNIER controls, R3A and R3B, respectively. A reference may be set at any point on the expanded monitor scale, by varying the reference supply output.

4-21. The output of the oscillator power amplifier is applied to the detector through an RCL network (A3C5, A3L1, A3R1), capacitor A3C2, and resistor A3R2. The purpose of the RCL network is to smooth the expand monitor circuit response on the X1M range. On the X10 range, A3C1 is switched in parallel with the RCL network and the input capacitor, A3C2, to improve the low frequency response of the circuit. It is not used on higher frequency ranges, due to an increase in detector time constant when it is connected.

4-22. The detector is a diode rectifier that provides a dc output proportional to the average value of the sinusoidal input from the oscillator power amplifier. The ac input is rectified by diodes A3CR1 and A3CR2, and applied to the base and emitter, respectively, of A3Q1, forward biasing the transistor. A3Q1 provides a low impedance path for the rectified signal, and allows average detection of the applied input with a single-ended output. A3L2, A3C6, and A3C7 form a filter network to remove any high frequency

components which might be present on the detector output. In addition, A3C3 is switched in on the X10 range to dampen the meter by reducing low frequency ripple.

4-23. The differential amplifier, A3Q2 and A3Q3, amplifies the difference between the filtered output of the detector and the reference voltage from the variable reference power supply. The output is taken from the collector of A3Q2, is further amplified by A3Q5, and is applied to the emitter follower, A3Q6. The emitter follower has a low output impedance and is used to drive the monitor. A3Q4 acts as a current source to provide approximately 50 microamps of current to the differential amplifier.

4-24. The reference power supply is a conventional series regulator type that has a variable output. Zener diode A3CR6 maintains a constant bias on the emitter of the reference amplifier, A3Q8. The base bias of A3Q8 is changed whenever the REF SET coarse or VERNIER controls are varied. This change is amplified and applied to the base of the series regulator, A3Q7. A3Q7 will change the reference supply output in direct proportion to the amount that the REF SET coarse or VERNIER controls are changed.

4-25. Two adjustments are provided for the expand monitor circuit: A3C11 and A3R14. A3C11 adjusts the expand monitor circuit response at 10 MHz, and A3R14 calibrates the monitor at 10 kHz.

4-26. OUTPUT ATTENUATOR.

4-27. The output attenuator provides a means of attenuating the signal level applied to the 50-ohm and 600-ohm output connectors. The OUTPUT ATTENUATOR switch, S2, selects a combination of four resistor networks to produce the desired level of signal attenuation. Each step provides an attenuation of 10 dB. The AMPLITUDE controls, R2A and R2B, vary the level of attenuation in increments between each 10 dB step selected by the OUTPUT ATTENUATOR switch.

4-28. Output impedances other than the standard 600-ohms can be obtained by changing the value of resistor S2R13. The value of the resistor replacing S2R13 is added to the 50-ohm oscillator output impedance to obtain the new output impedance level at the 600-ohm connector.

4-29. REGULATED POWER SUPPLY.

4-30. The regulated power supply provides all dc voltages required by the 652A Test Oscillator circuits. The power supply consists of a + 30 V and - 25 V series regulated supply. Each power supply is protected by current limiting and foldback current limiting.

4-31. The + 30 V and - 25 V power supplies are functionally identical. Both use operational amplifiers for output voltage error amplification. A1R40 adjusts the + 30 V supply voltage and A1R41 adjusts the - 25 V supply voltage.

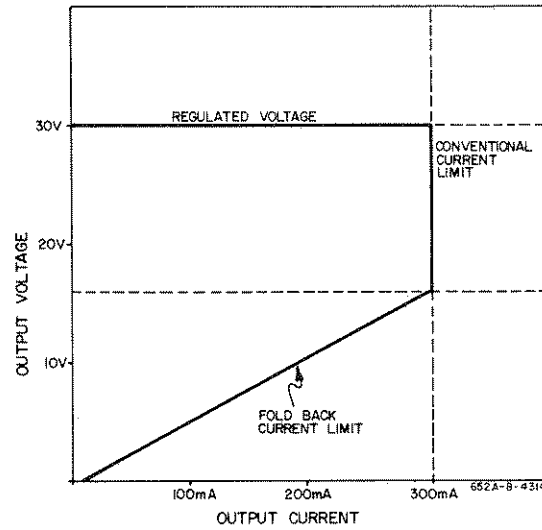

Figure 4-2. Regulated Power Supply Output Voltage vs. Current.

4-32. Conventional current limiting is used in both supplies to limit the output current to approximately 300 mA. Foldback current limiting further limits the output current if the output voltage is pulled below approximately 16 V by a malfunction in the 652A circuitry. A direct short to ground of either supply will result in an output current of approximately 10 mA as shown in Figure 4-2.

4-33. Figure 4-3 is a simplified schematic of the current limiting circuitry used in the 652A power supplies. The Current Limiting Transistor A1Q4(+) or A1Q7(-) is a variable shunt to the series regulator drive current. It is first switched on by the voltage drop across the Current Limit Sensing Resistor when the power supply output current reaches approximately 300 mA. The power supply will remain in this Conventional Current Limit condition until the output current decreases allowing the supply to return to normal operation, or until the power supply output voltage drops below the Foldback Reference (16.2 V). If the latter occurs, the Diode Switch is effectively closed and the power supply goes into a Foldback Current Limit condition. In this condition the Current Limiting Transistor is controlled by the power supply output voltage. As the output voltage decreases, the shunt current is increased.

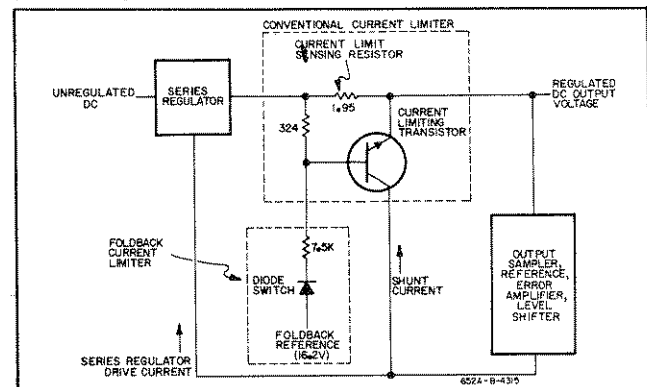

Figure 4-3. Simplified Schematic of Current Limiting Circuitry.

WARNING

These servicing instructions are for use by qualified personnel only. To avoid electrical shock, do not perform any servicing other than that contained in the operating instructions unless you are qualified to do so.

Table 5-1. Required Test Equipment.

Instrument Type	Required Characteristics	Recommended Model
Oscilloscope	Pass band: 10 Hz to 10 MHz Sensitivity: 50 mV/cm Input Impedance: 1 megohm	-hp- Model 180A Oscilloscope with 1801A and 1820A plug-ins
Electronic Counter	Range: 10 Hz to 10 MHz Accuracy: ± 5 counts	-hp- Model 5245L Electronic counter
AC Voltmeter	Frequency Range: 10 Hz to 10 MHz Voltage Range: 1 mV to 10 V Accuracy: $\pm 1\%$ DC output	-hp- Model 3400A RMS Voltmeter (with known accuracy)
Distortion Analyzer	Distortion Sensitivity: greater than 42 dB	-hp- Model 331A/332/333/334
Wave Analyzer	Frequency Range: 600 kHz to 22 MHz	-hp- Model H05-312A
DC Null Voltmeter	Range: 10 microvolts to 30 V Accuracy: $\pm 2\%$ of full scale	-hp- Model 419A
[†] AC Differential Voltmeter	Range: 1 V to 10 V Accuracy: $\pm 0.1\%$ Stability: $\pm 0.1\%$ Per Mo.	-hp- Model 741B AC-DC Differential Voltmeter/DC Standard
Attenuator	Attenuation Range: 90 dB in 10 dB steps Frequency Range: 10 Hz to 10 MHz	-hp- Model 355D VHF Attenuator (with known accuracy)
Amplifier	Gain: 40 dB Frequency Range: 10 Hz to 10 MHz	-hp- Model 461A Amplifier
Thermal Converter	Input: 3 V RMS Output: 7 mV dc Accuracy: $\pm 0.2\%$ Frequency Range: 10 Hz to 10 MHz Input Impedance: 50 ohms	-hp- Model 11049A Thermal Converter
0 to 10 mV Reference Supply	See Figure 5-3 for schematic a. Resistor: fxd, $6500 \Omega \pm 1\%$ b. Resistor: var, $500 \Omega \pm 5\%$ c. Resistor: var, $50 \Omega \pm 5\%$ d. Battery: 1.34 V	a. -hp- Part No. 0811-0392 b. -hp- Part No. 2100-0324 c. -hp- Part No. 2100-1481 d. Mallory RM-42R
Terminating Resistance	a. Feedthru, 50Ω b. Feedthru, 600Ω	a. -hp- Model 11048C b. -hp- Model 11095A
Adapter	BNC to Binding Post	-hp- Model 10111A Adapter
[†] Recorder	Chart Speed: 1"/hr or less	-hp- Model 680 6" Strip Chart Recorder
DC Digital Voltmeter	Range: 1 V Digits: 4	-hp- Model 34740A/34702A Measurement System

[†] Required only if Amplitude Stability Test (Paragraph 5-19) is performed.

SECTION V MAINTENANCE

5-1. INTRODUCTION.

5-2. This section contains maintenance and service information for the -hp- Model 652A Test Oscillator. Included are Performance Tests, Adjustment and Calibration Procedures, and Troubleshooting Procedures.

5-3. REQUIRED TEST EQUIPMENT.

5-4. The equipment needed to properly maintain the Model 652A is listed in Table 5-1. The table lists the type of equipment to be used, the specification requirements, and the recommended commercially available test equipment. If the equipment listed in Table 5-1 is not available, any instrument that satisfies the given specifications may be used.

5-5. PERFORMANCE TESTS.

5-6. The performance tests are in-cabinet tests which insure the Model 652A Test Oscillator is operating within specifications. These tests can be used for incoming inspection, periodic maintenance, and for specification tests after a repair. Use the performance tests to verify instrument performance before making internal adjustments or repairs. It is recommended that performance tests and calibration be performed at 6 month intervals. A removable test card is located at the end of Section V. This may be used for making a permanent record of the performance of the 652A during the Performance Tests.

NOTE

Paragraphs 5-18 and 5-19 are labeled as "Optional" tests for the following reasons: (Paragraph 5-18 Hum and Noise Test) Top cover of 652A must be removed to make this test. (Paragraph 5-19 Amplitude Stability Test) 652A output amplitude must be monitored continuously for one month to make this test.

5-7. Frequency Range Test.

a. Connect 652A 50 ohm output to dc input of electronic counter as shown in Figure 5-1.

- b. Set 652A controls as follows:
- | | |
|-------------------------|----------------------|
| FREQUENCY RANGE | X10 |
| FREQUENCY dial | Extreme
Clockwise |
| OUTPUT ATTENUATOR | 3.0 V |
| OUTPUT MONITOR | NORMAL |
| OUTPUT AMPLITUDE | |
| and VERNIER | 3.0 V on
monitor |

c. Counter should read a period average of 100 ms or greater, verifying a frequency of at least 10 Hz at lower end of frequency range.

d. Set 652A FREQUENCY RANGE to X1M and FREQUENCY dial to extreme counterclockwise position. Counter should read a frequency of 10 MHz or greater, verifying a frequency of at least 10 MHz at upper end of frequency range.

e. Perform Frequency Calibration, Paragraphs 5-27 through 5-34, if tolerances are not met.

5-8. Dial Accuracy Test.

a. Connect 652A 50 ohm output to dc input of electronic counter as shown in Figure 5-1.

- b. Set 652A controls as follows:
- | | |
|-------------------------|---------------------|
| FREQUENCY RANGE | X10 |
| FREQUENCY dial | 1 |
| OUTPUT ATTENUATOR | 3.0 V |
| OUTPUT MONITOR | NORMAL |
| OUTPUT AMPLITUDE | |
| and VERNIER | 3.0 V on
monitor |

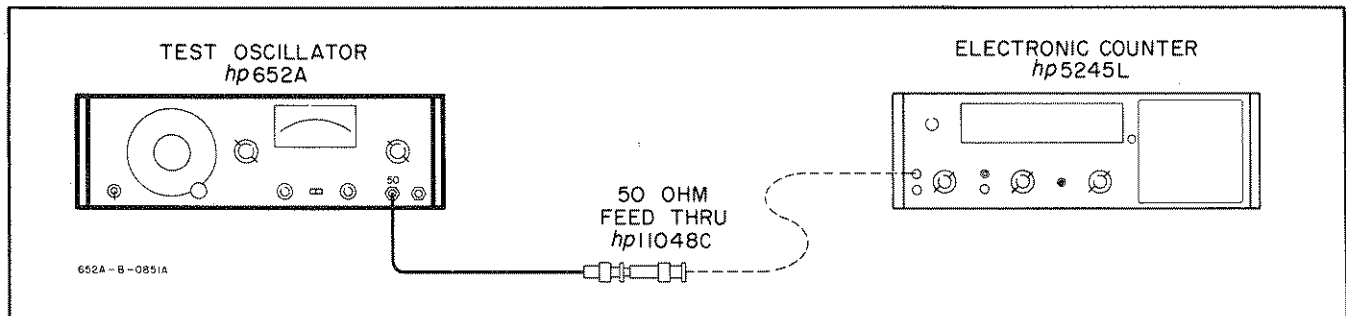

Figure 5-1. Frequency Tests.

c. Check all frequency settings given in Table 5-2. Set counter FUNCTION switch to PERIOD AVERAGE for frequencies below 1 kHz and FREQUENCY for higher frequencies. Table 5-2 lists the test frequencies and tolerances required.

d. Perform Frequency Calibration in Paragraphs 5-27 through 5-34 if tolerances are not met.

5-9. Output Tests.

5-10. Maximum Voltage.

a. Connect ac voltmeter to 50 ohm output terminal of 652A as shown in Figure 5-2.

b. Set 652A controls as follows:

FREQUENCY RANGEX1K
 FREQUENCY dial 10
 OUTPUT ATTENUATOR 3.0 V
 OUTPUT MONITORNORMAL

c. Adjust 652A OUTPUT AMPLITUDE and VERNIER controls for maximum output; ac voltmeter should indicate 3.16 V rms or greater.

d. Disconnect ac voltmeter from 50 ohm output terminal of 652A and connect to 600 ohm output. Replace 50 ohm load with a 600 ohm load.

e. Repeat Step c.

f. Perform Amplitude Adjustment in Paragraph 5-38 if tolerances are not met.

5-11. Flatness Test. (Amplitude not readjusted to a reference on the output monitor.)

NOTE

A thermal converter is a square law device. The dc output will change approximately twice the

Table 5-2. Dial Accuracy Test.

Frequency Dial	Range	Counter Indication
(counter set to indicate period average)		
1	X10	100 ± 3 ms
2.5	X10	40.0 ± 1.2 ms
5	X10	20.0 ± 0.6 ms
8	X10	12.5 ± 0.38 ms
10	X10	10.0 ± 0.3 ms
1	X100	10.0 ± 0.2 ms
2.5	X100	4.00 ± 0.08 ms
5	X100	2.00 ± 0.04 ms
8	X100	1.25 ± 0.03 ms
10	X100	1.00 ± 0.02 ms
(counter set to indicate frequency)		
1	X1K	1,000 ± 20 Hz
2.5	X1K	2,500 ± 50 Hz
5	X1K	5,000 ± 100 Hz
8	X1K	8,000 ± 160 Hz
10	X1K	10.0 ± 0.2 kHz
1	X10K	10.0 ± 0.2 kHz
2.5	X10K	25.0 ± 0.5 kHz
5	X10K	50.0 ± 1.0 kHz
8	X10K	80.0 ± 1.6 kHz
10	X10K	100.0 ± 2.0 kHz
1	X100K	100.0 ± 2.0 kHz
2.5	X100K	250.0 ± 5 kHz
5	X100K	500.0 ± 10.0 kHz
8	X100K	800.0 ± 16 kHz
10	X100K	1,000 ± 20 kHz
1	X1M	1,000 ± 30 kHz
2.5	X1M	2,500 ± 75 kHz
5	X1M	5,000 ± 150 kHz
8	X1M	8,000 ± 240 kHz
10	X1M	10,000 ± 300 kHz

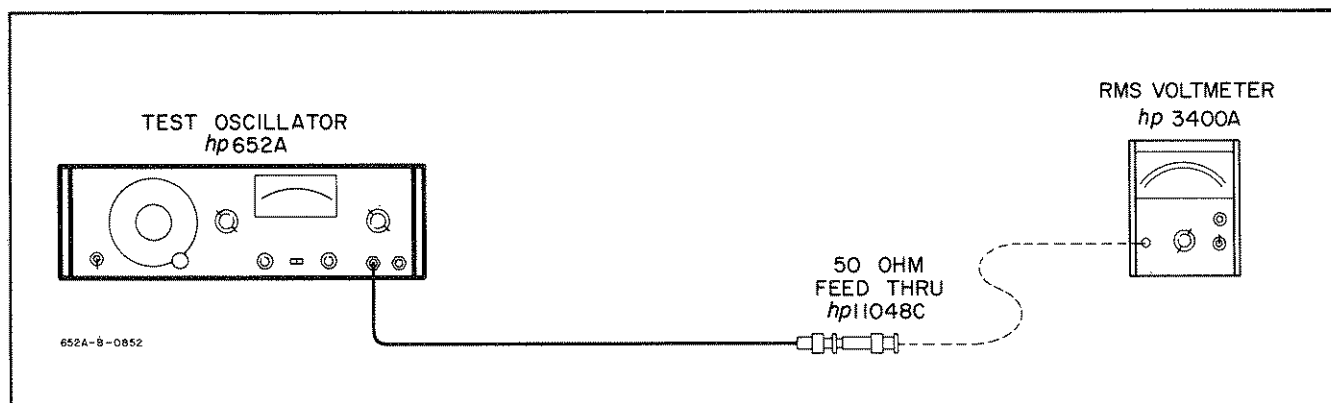

Figure 5-2. Output Tests.

percentage the ac input changes. Typically, it changes 1.7 times. When making response measurements, the transfer characteristics of your particular thermal converter should be used. To determine the thermal transfer characteristic of your particular thermal converter, proceed as follows:

1. Set the 652A output amplitude to minimum.
2. Connect the 11049A Thermal Converter directly to the 50 Ω output of the 652A.
3. Connect the 419A DC Nullmeter across the dc output of the Thermal Converter.
4. Adjust the 652A output amplitude control for 1 V rms input to the Thermal Converter (use an ac voltmeter to monitor the ac input to the Thermal Converter).
5. Measure and record the dc output (E_i) of the Thermal Converter on the 419A.
6. Double the ac input to 2 V rms. Again, observe the null meter and record the reading (E_f).
7. Calculate the transfer ratio as follows:

$$\text{Transfer characteristic } (k) = \frac{E_f}{2 E_i}$$

Table 5-3 assumes a transfer ratio of 2. The actual transfer ratio of your Thermal Converter should be applied to Table 5-3 as follows:

DC CHANGE = the percentage of ac ON 419A change times 7 mV times the transfer ratio.

For example, if the transfer ratio of your Thermal Converter is 1.7, a 1%

Table 5-3. Typical Thermal Converter Input/Output Change.

CHANGE AT AC INPUT OF THERMAL CONVERTER	CHANGE OF DC NULL METER INDICATION FROM NULL SETTING
+/- 0.25%	+/- 35 microvolts
+/- 1%	+/- 140 microvolts
+/- 2%	+/- 280 microvolts
+/- 3%	+/- 420 microvolts
+/- 4%	+/- 560 microvolts
The ac input is set for 7.0 mV at the output of the thermal converter.	

change in the ac input (Table 5-3) would result in 70 μV (change in ac input) times 1.7 (transfer ratio) = 119 μV.

- a. Connect equipment as shown in Figure 5-3. (Use a thermal converter with a known change in output for a given change at the input. If this information is not readily available, then Table 5-3 gives this information for a typical thermal converter connected as in Figure 5-3). Set both 652A output and reference supply to minimum before connecting. Thermal converter must be connected directly to 50 ohm output of 652A.



Do not exceed rated input of thermal converter. Any overload or high voltage transient may destroy thermoelement. When using the 652A FREQUENCY RANGE switch, momentarily turn down the output attenuator.

- b. Set 652A controls as follows:

FREQUENCY RANGEX1K
 FREQUENCY dial 10
 OUTPUT ATTENUATOR 3.0 V
 OUTPUT MONITORNORMAL

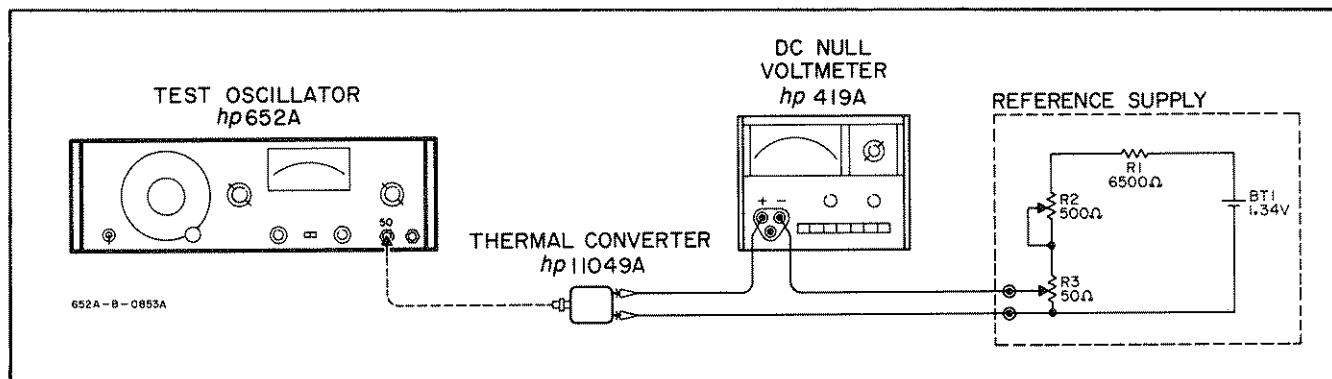

Figure 5-3. Flatness Tests.

c. Adjust 652A AMPLITUDE and VERNIER controls for dc null meter indication of 7.0 mV.

d. Adjust frequency supply for null indication. Do not readjust reference supply or 652A AMPLITUDE and VERNIER controls once null is obtained.

e. Adjusting 652A FREQUENCY RANGE switch and FREQUENCY dial as necessary, sweep 652A slowly over frequency range of 100 Hz to 1 MHz. Dc null meter reading will change above or below (or both) the null obtained in Step d. Record minimum and maximum readings of dc null meter; difference between these two readings should indicate a change in level of 652A output no greater than $\pm 2\%$ (see Table 5-3) verifying flatness specification over frequency range of 100 Hz to 1 MHz.

f. Repeat Step e over the range 10 Hz to 1 MHz. The difference between dc null meter maximum and minimum readings should indicate a change in level of 652A output no greater than $\pm 3\%$ (see Table 5-3) verifying flatness specification over frequency range of 10 Hz to 1 MHz.

g. Repeat Step e over the range of 10 Hz to 10 MHz. The difference between dc null meter maximum and minimum readings should indicate a change in level of 652A output no greater than $\pm 4\%$ (see Table 5-3) verifying flatness specification over frequency range of 10 Hz to 10 MHz.

h. Perform Frequency Calibration (Paragraphs 5-27 through 5-34) and 10 MHz Flatness Adjustments (Paragraph 5-35) if tolerances are not met.

5-12. Flatness. (Amplitude readjusted to a reference on the normal output monitor.)

a. Perform Step 5-11a. (Note CAUTION.)

b. Set 652A controls as follows:

FREQUENCY RANGE X10
FREQUENCY dial 2
OUTPUT ATTENUATOR 3.0 V
OUTPUT MONITOR NORMAL
AMPLITUDE and VERNIER Adjust
for a monitor indication of
3.0 V. (This adjustment is critical
as this will be the reference level
for Steps 5-12c through h.)

c. Adjust reference supply for null indication on dc null meter.

d. Set 652A FREQUENCY dial to 1.

e. Readjust 652A AMPLITUDE and VERNIER controls for 3.0 V on 652A OUTPUT MONITOR. (Do not readjust reference supply.) Record dc null meter indication.

f. Set 652A FREQUENCY dial for 12 Hz and repeat Step 5-12e.

g. Set 652A FREQUENCY dial for 15 Hz and repeat Step 5-12e.

h. To determine that the readings taken in Steps 5-12e, f, and g are within tolerance, two conditions must be met:

1) Each reading must be within 2% of the reference level established in Step 5-12b. (See Table 5-3.)

2) The difference between the highest and lowest reading must be no greater than 2% of the reference level established in Step 5-12b.

These two conditions verify 652A output flatness, when referenced to the normal monitor, of 2% between 10 Hz and 20 Hz.

i. Repeat Steps 5-12b through h (except, set up reference at 20 Hz and use the frequencies and tolerances listed in Table 5-4) to verify flatness of 1% over frequency range of 20 Hz to 4 MHz.

j. Repeat Steps 5-12b through h (except, set up reference level at 4 MHz and use the frequencies and tolerances listed in Table 5-4) to verify flatness of 2% over frequency range of 4 MHz to 10 MHz.

k. If tolerances are not met, first assure that tolerances of Paragraph 5-11 are met, then perform Normal Monitor Calibration of Paragraph 5-40.

5-13. Flatness. (Amplitude readjusted to a reference on expanded output monitor.)

a. Perform Step 5-11a (Note CAUTION).

b. Set 652A controls as follows:

FREQUENCY RANGE X10
FREQUENCY dial 2
OUTPUT ATTENUATOR 3.0 V
OUTPUT MONITOR NORMAL
OUTPUT AMPLITUDE and
VERNIER Adjust for a monitor
indication of 3.0 V.

c. Set OUTPUT MONITOR switch to EXPAND and adjust REF SET and VERNIER controls for 0% indication on the top (blue) scale of the 652A monitor.

d. Adjust reference supply for null indication on the dc null meter.

e. Set 652A FREQUENCY dial to 1.

f. Readjust 652A OUTPUT AMPLITUDE and VERNIER controls (if necessary) for 0% indication on 652A

Table 5-4. Flatness Test Settings and Limits*.

*(Amplitude readjusted to a reference on the output monitor)

FREQUENCY DIAL	FREQUENCY DIAL	TOLERANCE	
(10 Hz to 20 Hz)	X10	1	2%
	X10	1.2	2%
	X10	1.5	2%
	X10	2	2%
(20 Hz to 4 MHz)	X10	2	1%
	X100	1	1%
	X100	5	1%
	X1K	1	1%
	X1K	5	1%
	X10K	1	1%
	X10K	5	1%
	X100K	1	1%
	X100K	5	1%
	X1M	1	1%
	X1M	4	1%
(4 MHz to 10 MHz)	X1M	4	2%
	X1M	6	2%
	X1M	8	2%
	X1M	10	2%

monitor. (Do not readjust reference supply.) Record dc null meter indication.

g. Repeat Step f of this paragraph at each of the 652A FREQUENCY RANGE and FREQUENCY dial settings given in Table 5-4.

h. To determine that the readings recorded in Steps f and g are within tolerance, two conditions must be met:

- 1) Each reading must be within 0.5% of the reference level established in Step c.

2) The difference between the highest and lowest readings must be no greater than 0.5% of the reference level established in Step c. These two conditions verify 652A output flatness, referenced to the expanded monitor, of $\pm 0.25\%$ over the frequency range of 10 Hz to 10 MHz.

- i. If flatness specifications are not met, first assure that tolerances of Paragraphs 5-11 and 5-12 are met, then perform calibration procedure of Paragraphs 5-37 and 5-38.

5-14. Output Monitor Accuracy Test.

a. Connect ac voltmeter to 50 ohm output terminal of 652A as shown in Figure 5-2. Use an ac voltmeter with known accuracy at frequency to be used (400 Hz).

b. Set 652A controls as follows:

FREQUENCY RANGE X100
 FREQUENCY dial 4
 OUTPUT ATTENUATOR 3.0 V
 OUTPUT MONITOR NORMAL

c. Set OUTPUT AMPLITUDE and VERNIER controls for a 3.0 V indication on 652A monitor. AC voltmeter should indicate $3\text{ V} \pm 0.06\text{ V}$ ($\pm 2\%$)rms, verifying an output monitor accuracy of $\pm 2\%$ of full scale.

d. If tolerance is not met, perform Normal Monitor Calibration, Paragraph 5-40.

5-15. Attenuator Test.

a. Connect external attenuator, amplifier, ac voltmeter and digital voltmeter to 652A as shown in Figure 5-4. Use an attenuator with known accuracy.

NOTE

Float amplifier, ac voltmeter and digital voltmeter using an adequate isolation transformer to isolate chassis ground from power line ground.

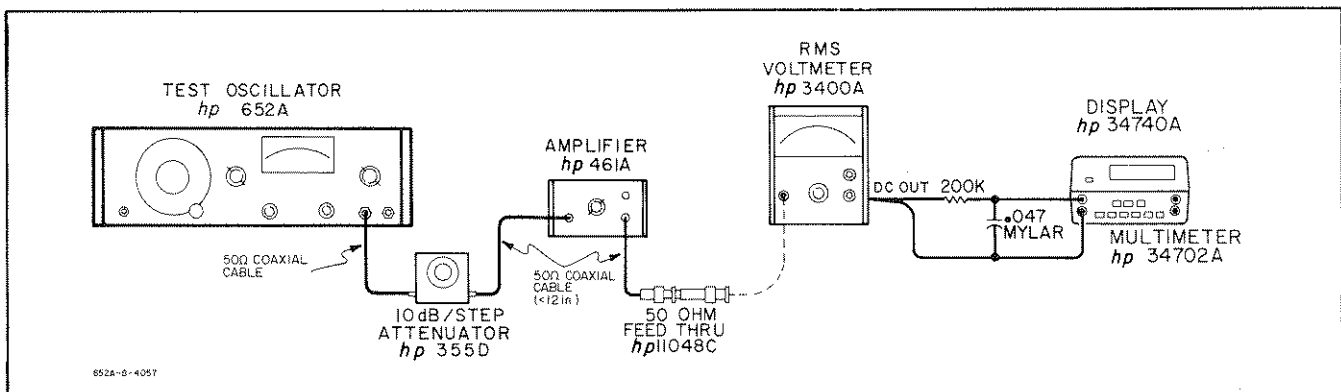

Figure 5-4. Attenuator Test.

b. Set 652A controls as follows:

FREQUENCY RANGEX1K
FREQUENCY dial 1
OUTPUT ATTENUATOR 3.0 V
OUTPUT MONITORNORMAL

c. Set 355D attenuator switch to 90 dB position.

d. Set 461A amplifier gain switch to 40 dB position.

e. Turn the 652A AMPLITUDE and VERNIER controls maximum clockwise. Select the range on the 3400A that gives an indication of > 1.0000 V dc on the 34740A. Now adjust the AMPLITUDE controls to give a 1.0000 V dc reading on the 34740A.

NOTE

Do not readjust the 652A AMPLITUDE and VERNIER controls during this test.

f. Check 652A OUTPUT ATTENUATOR in each position by decreasing attenuation on external attenuator as attenuation is increased on 652A. Digital voltmeter indication should be:

- 1) 1.0000 ± .0075 V dc for 3 V through .3 mV ranges (+ 20 dB 59 - 60 dB) verifying an overall accuracy of ± .075 dB from + 20 dBm to - 60 dBm.
- 2) 1.0000 ± 0.02 V dc for 0.1 mV range (- 70 dB) verifying an accuracy of ± 0.02 dB for the - 70 dBm position.

g. Repeat Steps c through f of this paragraph with 652A frequency set to 10 MHz.

h. If attenuation is out of tolerance, refer to Paragraph 5-57.

5-16. Amplitude Control Test.

a. Connect ac voltmeter to 50 ohm output terminal as shown in Figure 5-2.

b. Set 652A controls as follows:

FREQUENCY RANGE X100
FREQUENCY dial 4
OUTPUT ATTENUATOR 3.0 V
OUTPUT MONITORNORMAL
OUTPUT AMPLITUDE
and VERNIERExtreme Clockwise

c. Note reading on ac voltmeter.

d. Set OUTPUT AMPLITUDE and VERNIER controls to extreme counterclockwise position. AC voltmeter should read 20 dB or more below reading noted in Step c. This verifies an amplitude control of at least 20 dB.

5-17. Distortion Test.

a. Connect distortion analyzer to 652A as shown in Figure 5-5.

b. Set 652A controls as follows:

FREQUENCY RANGEX1K
FREQUENCY dial 1
OUTPUT ATTENUATOR 3.0 V
OUTPUT MONITORNORMAL
OUTPUT AMPLITUDE
and VERNIERAdjust for
monitor indication
of 3.0 V.

c. Distortion level, as indicated on distortion analyzer, should be less than 1%.

d. Repeat Steps b and c to check distortion at each of frequency settings shown in Table 5-5 (Part A).

e. Disconnect 652A output from distortion analyzer and connect to wave analyzer (remove 50 ohm feedthru termination).

f. Check distortion at each of frequency settings shown in Table 5-5 (Part B). Use the following formula to compute distortion.

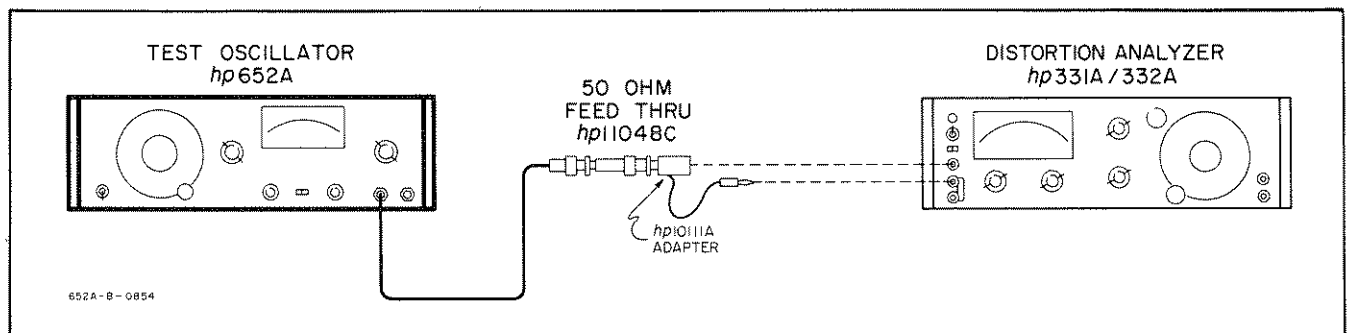

Figure 5-5. Distortion Test.

Table 5-5. Distortion Test.

FREQUENCY RANGE	FREQUENCY DIAL	DISTORTION
Part A		
X10	1	less than 1%
X100	1	less than 1%
X1K	1	less than 1%
X10K	1	less than 1%
X100K	1	less than 1%
X100K	5	less than 1%
Part B		
X1M	2	less than 1%
X1M	5	less than 2%
X1M	10	less than 4%

$$\% \text{ distortion} = \frac{100 \sqrt{E_2^2 + E_3^2 + \dots}}{E_1}$$

E_1 = rms voltage of fundamental frequency;

E_2 = rms voltage of second harmonic;

E_3 = rms voltage of third harmonic;

etc.

g. Perform Minimum Distortion Adjustment, Paragraph 5-39, if tolerances are not met.

5-18. Hum and Noise Test (Optional).

a. Connect ac voltmeter to 50 ohm output of 652A as shown in Figure 5-2.

b. Set 652A controls as follows:

FREQUENCY RANGE X100
 FREQUENCY dial 10
 OUTPUT ATTENUATOR 3.0 V
 OUTPUT MONITOR NORMAL

c. Adjust 652A OUTPUT AMPLITUDE and VERNIER controls for a reading of 0 dB on 3 V range of ac voltmeter.

d. Remove top cover of 652A and short out tuner by clipping a lead from the solder lug on tuner frame to chassis.



Lead dress is critical to frequency accuracy and flatness.

Residual hum and noise should read greater than -66 dB from 0 dB reference set on rms voltmeter in Step c.

e. Remove clip lead and replace 652A top cover.

5-19. Amplitude Stability Test (Optional).

a. Connect ac differential voltmeter and strip chart recorder to 652A as shown in Figure 5-6.

NOTE

Float ac differential voltmeter by using an isolation transformer to isolate chassis ground from ac power line ground.

o. Set 652A controls as follows:

FREQUENCY RANGE X1K
 FREQUENCY dial 1
 OUTPUT ATTENUATOR 3.0 V
 OUTPUT MONITOR NORMAL

c. Adjust 652A OUTPUT AMPLITUDE and VERNIER controls for a 3.000 V indication on differential voltmeter.

d. Set recorder output adjustment of ac differential voltmeter so that a ± 0.06 V variation of 652A output can be easily recorded.

e. The output of 652A should not vary by more than ± 2% over a period of one month when temperature remains between 20°C and 30°C.

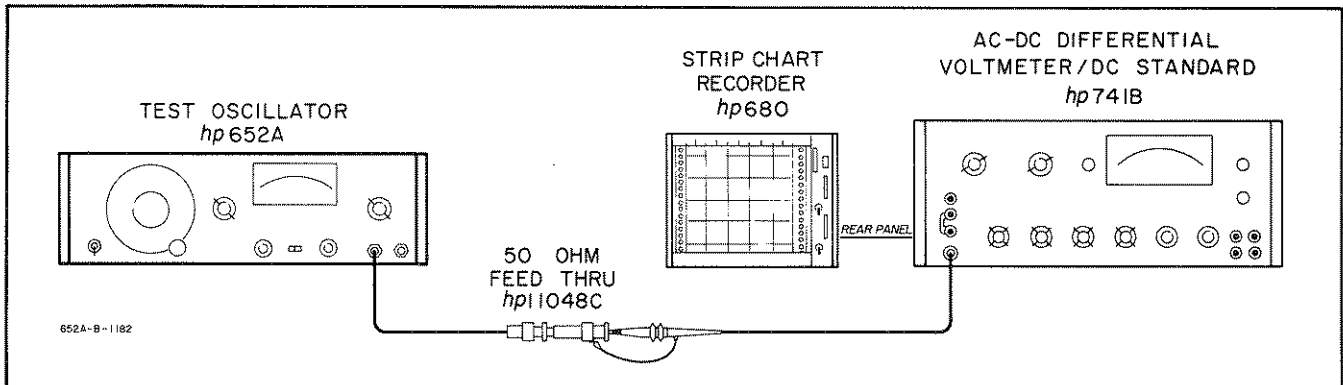

Figure 5-6. Amplitude Stability Test.

5-20. Output Impedance Test.

a. Connect 50 ohm output of 652A directly to ac voltmeter.

b. Set 652A controls as follows:

FREQUENCY RANGEX1K
FREQUENCY dial 1
OUTPUT ATTENUATOR 3.0 V
OUTPUT MONITORNORMAL

c. Adjust 652A OUTPUT AMPLITUDE and VERNIER controls for a 6.0 V rms indication on ac voltmeter.

d. Insert 50 ohm feedthru load between 652A and ac voltmeter. AC voltmeter indication should drop to 3.0 V \pm 0.15 V rms, verifying a 50 ohm output impedance.

e. Remove 50 ohm feedthru load and disconnect cable to 50 ohm output of 652A.

f. Connect 600 ohm output of 652A directly to ac voltmeter.

g. Adjust 652A OUTPUT AMPLITUDE and VERNIER controls for a 6.0 V indication on ac voltmeter.

h. Insert a 600 ohm load between 652A and ac voltmeter. AC voltmeter indication should drop to 3.0 V \pm 0.15 V rms, verifying a 600 ohm output impedance.

5-21. ADJUSTMENT AND CALIBRATION PROCEDURE.

5-22. The following is a complete adjustment and calibration procedure for the Model 652A. The adjustments should be performed only if it has been determined by the Performance Tests that the 652A is not within specifications. Figure 5-7 shows the location of all internal adjustments.



The 652A contains high impedance, high frequency circuits. Contamination of the switches, circuit boards or tuning capacitor will cause high impedance leakage paths and subsequent deterioration of the performance of the instrument. Avoid touching any of these circuits with the bare fingers, as skin oils are extremely contaminating. If handling is necessary, wear clean cotton or rubber gloves. Do not use a pencil to trace circuits in the instrument. Graphite pencil lead is an extremely good conductor and an accidentally introduced path of this type is sometimes difficult to locate. To avoid surface contamination of a printed circuit or switch, clean with a weak solution of warm water and mild detergent after repair. Rinse thoroughly with clean water

and allow it to dry completely before operating. Do not use alcohol or any other cleaning solution except mild detergent and water. Do not apply any commercial moisture sealing spray to the boards; application of these agents may cause leakage paths.

5-23. Cover Removal.

5-24. To remove top or bottom cover, remove two retaining screws from sides of cover; slide cover about 1/2 inch to rear; lift it off. To replace cover, reverse procedure.

5-25. To remove side cover, remove two retaining screws in cover and lift it off.

5-26. Power Supply Voltage Adjustments.

a. Connect dc voltmeter to power supply positive output, connector point 1. (Refer to Figure 6-4.)

b. Adjust A1R40 (+ 30 V ADJUST) for a dc voltmeter indication of + 30 V \pm 0.75 V.

c. Connect dc voltmeter to power supply negative output, connector point 2. Adjust A1R41 (- 25 V ADJUST) for a dc voltmeter indication of - 25 V \pm 0.75 V.

5-27. FREQUENCY CALIBRATION PROCEDURES.

a. During this procedure each range is calibrated individually; the capacitors for each range are adjusted at the high end (FREQUENCY dial at 10) and the resistors are adjusted at the low end (dial at 1). The tuning capacitor (C1A, B, C) mechanical adjustments are made on the X1K RANGE, also the two test point voltages (A2TP1, and A2TP2), which are interactive, are determined on this range. The voltage at A2TP1 effects distortion so must not be set outside the limit of 110 \pm 10 mV rms.

b. The negative dc voltage at A2TP2 effects the instrument output flatness; it is important to ensure that this voltage is within limits at both the high and low end of each range; the limits are given in the procedure for each range. Towards the center of each range the voltage can vary; the required limits are given in the procedure for each range but no adjustments can be made. On some instruments the voltage may drop below the required limit; provided that it does not drop below - 200 mV and the instrument still meets output flatness and distortion specifications then this is acceptable. If it does drop below - 200 mV or if flatness or distortion is not met then it will be necessary to change components, by trial and error, on the A2 Board and repeat the calibration procedure for all ranges (the most likely components to change would be A2CR6, A2CR7, A2Q2 and A2Q3).

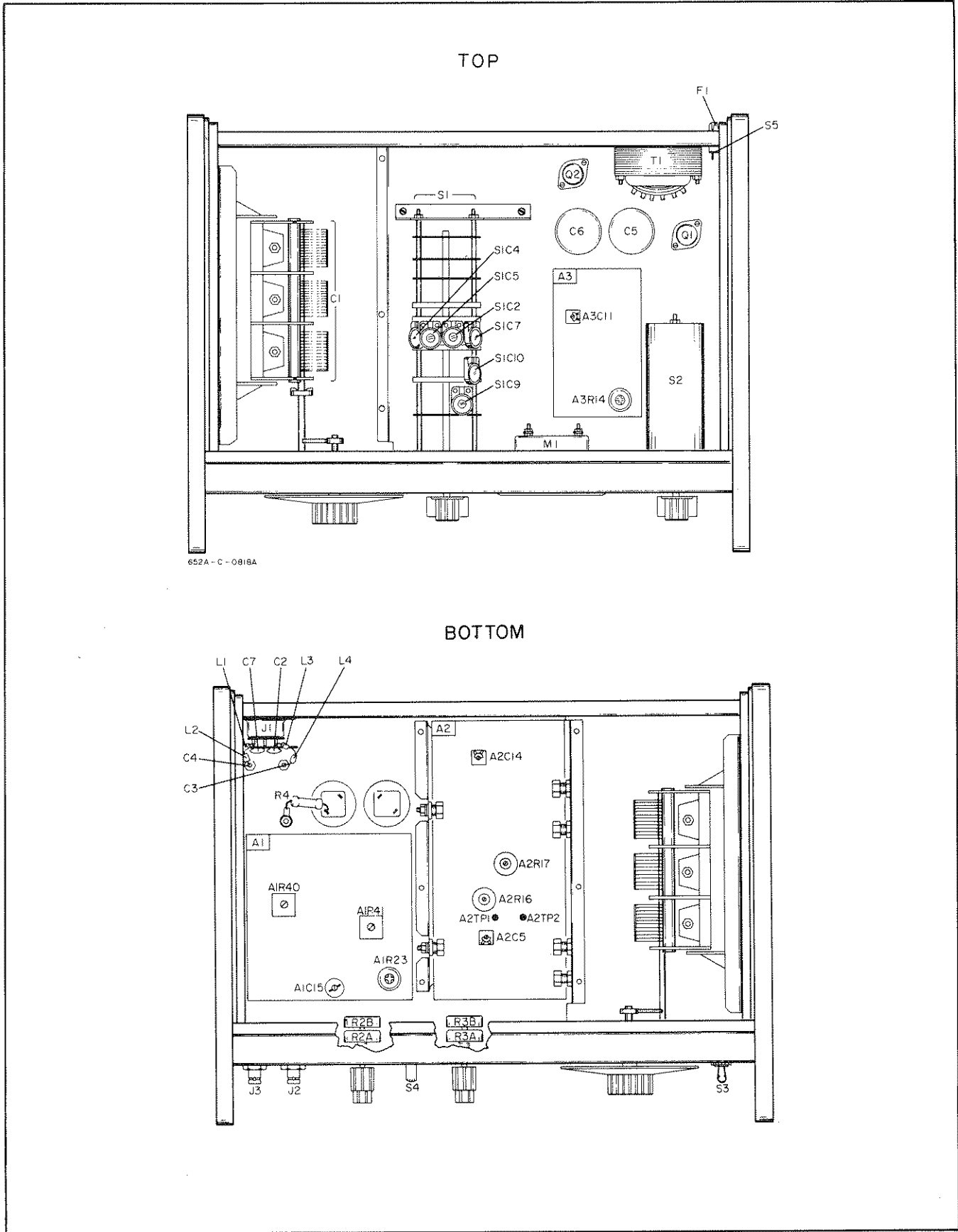

Figure 5-7. Location of Internal Adjustments.

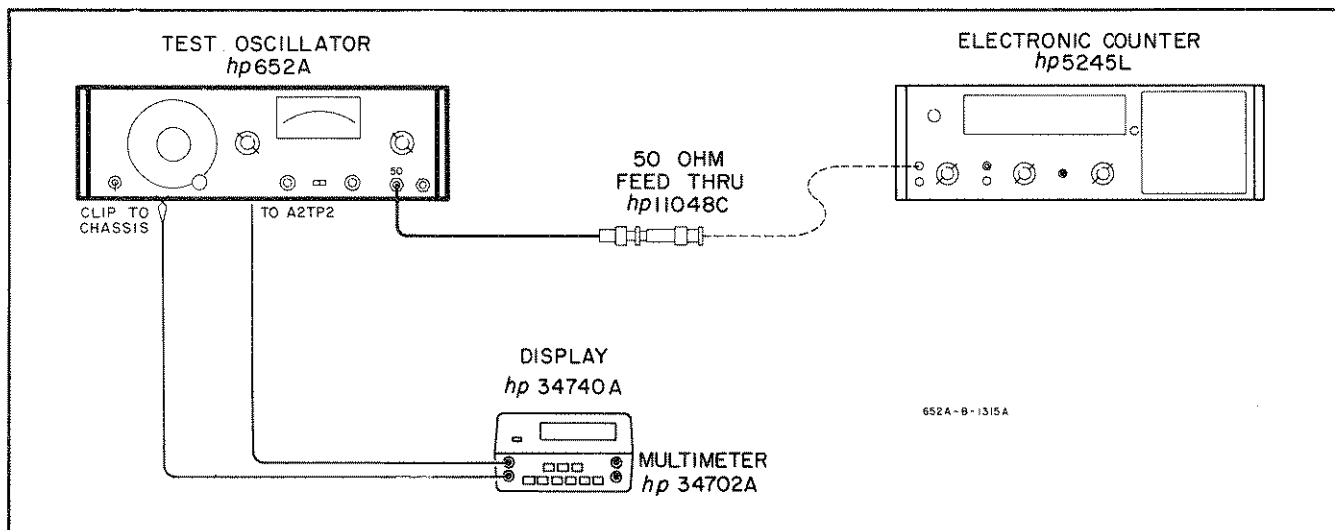

Figure 5-8. Frequency Calibration.

NOTE

It is important to ensure that the X1K RANGE calibration is completed before proceeding to the other ranges as these are referenced to the X1K RANGE.

c. The frequency calibration setup is shown in Figure 5-8. Output frequency should be continuously monitored at the 50 ohm output with a counter. DC voltage at A2TP2 should also be monitored continuously, after Paragraph 5-28 has been performed.

d. Table 5-7 lists frequency accuracy required at each test frequency.

NOTE

If any adjustments are necessary, the top and bottom covers should be in place when final frequency and A2TP2 voltage tests are made. All internal shields must be in place and held firmly by retaining screws. If desired, Figure

5-10 gives a scaled drawing of top and bottom alignment access covers with cut-outs that will allow adjustments while the covers are in place. The dimensions are given in inches.

e. The adjustments available for each range are listed in Table 5-6. Some of these components listed change both frequency and A2TP2 voltage in the same direction while the others change them in opposite directions. If the adjustments do not provide specified performance, then the procedure for changing padding resistors of Table 5-6 should be carefully followed.

NOTE

If 652A does not oscillate, turn FREQUENCY RANGE switch to X1K and adjust A2C5, S1C2 and S1C7 to start oscillations.

5-28. Preliminary Distortion Adjustment.

a. Connect 652A to distortion analyzer as shown in Figure 5-5.

Table 5-6. Frequency Calibration Components.

(Increasing the value of any of these components will decrease the frequency and change the A2TP2 voltage as indicated.)

FREQUENCY RANGE	FREQUENCY DIAL READING = 10		FREQUENCY DIAL READING = 1	
	Decreases A2TP2 Voltage	Increases A2TP2 Voltage	Increases A2TP2 Voltage	Decreases A2TP2 Voltage
X10		S1C15*	S1R1*	S1R14*
X100			S1R3*	S1R16*
X1K	S1C2	S1C7	S1R5*	S1R18*
X10K		S1C13*	S1R7*	S1R20*
X100K	S1C4	S1C9	S1R9*	S1R22*
X1M	S1C5	S1C10, S1C14* and A2C5	S1R11*	S1R24*

- b. Set 652A controls as follows:

FREQUENCY RANGE X1K
 FREQUENCY dial 1
 OUTPUT ATTENUATOR 3.0 V
 AMPLITUDE (COARSE
 and FINE) Extreme Clockwise

- c. Adjust A2R17 for minimum distortion which should be less than 1%.

5-29. Frequency Dial Calibration.

- a. Preliminary mechanical adjustments (Perform only if necessary).

1. To prevent gear backlash problems during alignment, make sure that there is no movement between MP1 and MP2. See Figure 6-1. (They must be pressed tightly together.) Also MP3, 4, and MP5 spring gear assembly must be under tension.
2. Check to make sure that the stop MP6 prevents the tuning capacitor from being completely closed. MP6 should hold the capacitor at least 1/16 inch open. Adjust if necessary.
3. With the dial set to maximum clockwise position, slip the dial face such that the first mark left of 1 is 1/16 inch to the right of the fixed indicator. To slip dial, remove Frequency dial knob and loosen 4 dial retaining screws. After slipping dial, retighten the screws.

- b. Attach test lead to A2TP2; lead should be connected so that A2TP2 voltage can be monitored with bottom cover in place. Replace bottom cover. Care should be taken that test lead does not short to oscillator shield or instrument chassis. Do not remove oscillator shield; it affects calibration.

- c. Connect equipment as shown in Figure 5-8 and set 652A controls same as Paragraph 5-28b.

- d. Set the 652A controls as in Paragraph 5-28(b). Adjust A2R16 for $-370 \text{ mV} \pm \frac{\text{X}}{10} \text{ mV}$ at A2TP2.

- e. Set 652A FREQUENCY dial extremely counter-clockwise and adjust S1C2 and S1C7 alternately for counter indication of 10.2 kHz and A2TP2 voltage equal to voltage recorded in Step d.

- f. Turn 652A FREQUENCY dial to extreme clockwise position; counter should indicate frequency of 965 Hz to 970 Hz; if not, loosen tuner coupler (MP6, Figure 7-1) and slip tuner until specified frequency is obtained. (See CAUTION).

- g. Set 652A FREQUENCY dial for a counter indication of 1 kHz. Dial should read 1; if not, carefully perform following procedure:

1. Remove FREQUENCY dial knob and loosen four dial retaining screws.
2. Slip FREQUENCY dial to read 1 with counter indication of 1 kHz.
3. Tighten retaining screws and replace knob.

- h. Readjust A2R16 to $-370 \text{ mV} \pm \frac{\text{X}}{10} \text{ mV}$ at A2TP2.

- i. Set 652A FREQUENCY dial to 10. Readjust S1C2 and S1C7 alternately until counter indicates frequency of 10 kHz and an A2TP2 voltage of -370 mV .

- j. Reset MP6 stop so that "10" on the dial can be turned to a position approximately 1/8 inch to the left of the fixed indicator.



The adjustments in Paragraphs 5-30 through 5-33 are highly critical. The values of the range switch resistors were bridged at the factory for optimum performance, and theoretically should never have to be changed. Double check the instrument performance before changing the values of any of the range switch resistors.

5-30. X1K Range Adjustments.

- a. Set 652A FREQUENCY RANGE to X1K and FREQUENCY dial to 1.

- b. Remove 652A bottom cover and oscillator shield. Connect ac voltmeter with 1 kilohm resistor in series to A2TP1 and ground. Replace oscillator shield and bottom cover.

- c. AC Voltmeter should indicate $110 \pm 10 \text{ mV rms}$. If A2TP1 voltage is not in tolerance, adjust A2R16 to bring voltage within specified limits (increasing A2R16 decreases A2TP1 voltage, and vice versa).

- d. The dc voltage at A2TP2 should be between 400 mV and -320 mV . If not, change the value of S1R5* and S1R18* simultaneously (See Table 5-6) until A2TP2 voltage is within tolerance and frequency is 1 kHz. Do not solder the resistors in place.

- e. Repeat Steps c and d of this paragraph (if necessary) until A2TP1, A2TP2 and the frequency are all within tolerance. Solder S1R5* and S1R18* in place.

CHANGES PER HP SUPPLEMENT A, DATED 27 NOV 79. (27 DEC 82-DMK)

- f. Record the dc voltage at A2TP2.

NOTE

This voltage will be the reference voltage referred to in the remaining section of the Frequency Calibration procedure.

- g. Set 652A FREQUENCY dial to 10. Readjust S1C2 and S1C7 alternately (See Table 5-6) until frequency indicated on counter is 10 kHz and A2TP2 voltage is the same as reference voltage recorded in Step f \pm 10 mV.

- h. Check frequency tracking of the dial using settings and tolerances given in Table 5-7 for the X1K RANGE. A2TP2 voltage should not vary more than 40 mV from the voltage recorded in Step f.

Table 5-7. Frequency Dial Accuracy Calibration.

Frequency Dial	Frequency Range	Counter Indication
		(counter set to read period average)
1	X10	100 \pm 3 ms
2	X10	50 \pm 1.5 ms
5	X10	20 \pm 0.6 ms
8	X10	12.5 \pm 0.38 ms
10	X10	10 \pm 0.3 ms
1	X100	10 \pm 0.2 ms
2	X100	5 \pm 0.1 ms
5	X100	2 \pm 0.04 ms
8	X100	1.25 \pm 0.03 ms
10	X100	1 \pm 0.02 ms
		(counter set to read frequency)
1	X1K	1,000 \pm 20 Hz
2	X1K	2,000 \pm 40 Hz
5	X1K	5,000 \pm 100 Hz
8	X1K	8,000 \pm 160 Hz
10	X1K	10.0 \pm 0.2 kHz
1	X10K	10.0 \pm 0.2 kHz
2	X10K	20.0 \pm 0.4 kHz
5	X10K	50.0 \pm 1.0 kHz
8	X10K	80.0 \pm 1.6 kHz
10	X10K	100.0 \pm 2.0 kHz
1	X100K	100.0 \pm 2.0 kHz
2	X100K	200.0 \pm 4.0 kHz
5	X100K	500.0 \pm 10 kHz
8	X100K	800.0 \pm 16 kHz
10	X100K	1,000 \pm 20 kHz
1	X1M	1,000 \pm 30 kHz
2	X1M	2,000 \pm 60 kHz
5	X1M	5,000 \pm 150 kHz
8	X1M	8,000 \pm 240 kHz
10	X1M	10,000 \pm 300 kHz

5-31. X100 and X10K Range Frequency Calibration.

- a. Connect equipment as shown in Figure 5-8.
- b. Check frequency tracking of FREQUENCY dial at 1, 2, 5, 8, and 10 on the X100 and X10K ranges (See Table 5-7) while monitoring voltage at A2TP2. At 1 and 10 on the dial, A2TP2 voltage should be within \pm 20 mV of reference voltage noted in Paragraph 5-30, Step f; over the entire range of the dial, A2TP2 voltage should not vary more than 40 mV.
- c. On each range, if frequency or A2TP2 voltage is not correct at 1 on dial, change the value of RANGE switch resistors (Table 5-6) for that range. (The two resistors should be changed simultaneously for the best results.)
- d. On X10K range, if the frequency or A2TP2 voltage is not correct at 10 on dial, change the value of the padding capacitor, S1C13, Table 5-6.

5-32. X10 Range Frequency Calibration.

- a. Connect equipment as shown in Figure 5-8.
- b. Set 652A FREQUENCY RANGE to X10. Check frequency as indicated on counter (See Table 5-7) at 1 and 10 positions of FREQUENCY dial.
- c. If either frequency or A2TP2 voltage is not within tolerance, change values of S1R1* and S1R14* (Table 5-6) simultaneously to bring frequency within tolerance and maintain A2TP2 at required voltage (within +0.00 V, -0.05 V of reference voltage noted in Paragraph 5-30, Step f).

NOTE

It may be necessary to split difference in frequency between the two ends of the dial.

- d. Check frequency at the 2 and 5 positions of the dial. If not within tolerance (Table 5-7), repeat Paragraph 5-30, Steps b and c.

5-33. X1M Range Frequency Calibration.

NOTE

The following adjustments are critical. For each adjustment, remove covers and make the adjustment; then replace covers before making frequency or voltage tests. If desired, Figure 5-10 gives a scaled drawing of top and bottom alignment access covers with cut-outs that will allow adjustments while the covers are in place. The dimensions are given in inches.

- a. Connect the equipment as shown in Figure 5-8.

b. Set 652A FREQUENCY RANGE switch to X1M and FREQUENCY dial to 10. If 652A does not oscillate, adjust A2C5, S1C5 and S1C10.

c. Adjust A2C5 and S1C5 alternately for 10.15 MHz (1.5% high) as indicated on counter and for required voltage on A2TP2 (within ± 0.02 V of reference voltage recorded in Paragraph 5-30, Step f). *If the required frequency and A2TP2 voltage cannot be obtained, change the setting of S1C10 and repeat this step.*

d. Set FREQUENCY dial to 5 and note frequency; if not within tolerance (Table 5-7), perform the following:

1. Set dial to 10 and slightly change setting of S1C10. (Example: If frequency is low with 5 set on dial, adjust S1C10 to slightly lower frequency when dial is at 10; and vice versa.)
2. Readjust A2C5 and S1C5 alternately for 10.15 MHz and required A2TP2 voltage (same as Step c).
3. Set dial to 5 and note frequency; if still not within tolerance, repeat Steps d-1, d-2, and d-3 as often as necessary until tolerances are met at both 5 and 10 positions of FREQUENCY dial. If necessary, change the value of S1C14*.

e. Set FREQUENCY dial to 1. Check that frequency (Table 5-7) and A2TP2 voltage (same as in Step c) are within required tolerances; if either is not correct, change value of RANGE switch resistors (Table 5-6) simultaneously until both frequency and voltage are within required limits. If RANGE switch resistors are changed, it will be necessary to repeat Steps c and d.

f. Set FREQUENCY dial to 2; counter should indicate 2000 ± 60 kHz.

NOTE

It may be necessary to set frequency about 1% high for the dial to track.

g. While monitoring the voltage at A2TP2, move the dial through its range from 1 to 10; the A2TP2 voltage must remain within the range: -300 mV to -450 mV. If A2TP2 voltage exceeds these limits, then recalibrate using Paragraph 5-33.

5-34. X100K Range Frequency Calibration.

NOTE

The following adjustments are critical. For each adjustment, remove cover and make the adjustment; then replace cover before making frequency or voltage checks. If desired, Figure 5-10 gives a scaled drawing of top and bottom

alignment access covers with cut-outs that will allow adjustments while the covers are in place. The dimensions are given in inches.

a. Connect equipment as shown in Figure 5-8.

b. Set FREQUENCY RANGE to X100K and FREQUENCY dial to 10. Adjust S1C4 and S1C9 simultaneously for 1 MHz (See Table 5-7) as indicated on counter and for required A2TP2 voltage (within ± 0.02 V of reference voltage recorded in Paragraph 5-30, Step f).

c. Set FREQUENCY dial to 1. Counter should indicate 100 kHz (See Table 5-7) and A2TP2 voltage should be the same as in Step b; if either is not within tolerance, change value of RANGE switch resistors (Table 5-6) simultaneously until both frequency and voltage are within required limits.

d. Repeat Step b.

e. Set FREQUENCY dial to 5; frequency should be 500 kHz (See Table 5-7) as indicated on counter and A2TP2 voltage should be within 40 mV of reference voltage. If either is incorrect, repeat Steps b, c, and d until both frequency and A2TP2 voltage are within tolerance. (Remove test lead attached to A2TP2.)

5-35. 10 MHz Flatness Adjustment.

a. Connect 652A to ac voltmeter as shown in Figure 5-2.

b. Set 652A controls as follows:

```
FREQUENCY RANGE .....X1K
FREQUENCY dial ..... 10
OUTPUT ATTENUATOR ..... 3.0 V
OUTPUT MONITOR .....NORMAL
```

c. Adjust 652A OUTPUT AMPLITUDE and VERNIER controls for 3.0 V rms as indicated on ac voltmeter. Do not readjust AMPLITUDE controls for remainder of this paragraph.

d. Connect equipment as shown in Figure 5-3. Adjust reference supply for null indication. Do not readjust reference supply once null is obtained.

NOTE

Instrument covers must be in place.

e. Set 652A FREQUENCY RANGE to X1M. Sweep FREQUENCY dial slowly from 1 to 10. Null meter deviation from null should not exceed ± 0.54 mV.

f. Adjust A2C14 to reduce any output peaking. If necessary, change value of A2C24* slightly.

5-36. Output Adjustments.**5-37. Amplitude Adjustment.**

a. Connect 652A to ac voltmeter, as shown in Figure 5-2.

b. Set 652A controls as follows:

FREQUENCY RANGE X10
 FREQUENCY dial 1
 OUTPUT ATTENUATOR 3.0 V
 AMPLITUDE Fully Clockwise

c. AC Voltmeter should indicate at least 3.16 V rms. If maximum output is less than 3.16 V, slightly decrease value of A2R24*.

5-38. Waveform Adjustment.

a. Connect a 50 Ω load to a 652A 50 Ω output terminal, and connect the output to an oscilloscope.

b. Set OUTPUT ATTENUATOR to 3.0 V, and turn OUTPUT AMPLITUDE and VERNIER controls fully counterclockwise.

c. Check 652A output with and without load on all frequencies for spurious oscillations. Spurious oscillations most likely occur in the output amplifier. A slight increase in the value of A2R29 should eliminate this. If spurious oscillations still occur, then change the value of A2C21 slightly. (If A2C21 is changed, then recheck 1 MHz Frequency Calibration, Paragraph 5-33.)

d. Since there is a direct interaction between Waveform Adjustment and Amplitude Adjustment, recheck Amplitude Adjustment.

5-39. Minimum Distortion Adjustment.

a. Connect 652A to distortion analyzer as shown in Figure 5-5.

b. Set 652A controls as follows:

FREQUENCY RANGE X1K
 FREQUENCY dial 1
 OUTPUT ATTENUATOR 3.0 V
 OUTPUT AMPLITUDE
 and VERNIER Fully clockwise

c. Adjust A2R17 for minimum distortion as indicated on distortion analyzer. Distortion should be less than 1% (40 dB down).

NOTE

Distortion will be typically 50 dB down.

5-14

5-40. Normal Monitor Calibration.**NOTE**

The following adjustments are critical. Final voltage measurements must be made with all instrument covers in place.

a. Connect 652A to ac voltmeter as shown in Figure 5-2.

b. Set 652A controls as follows:

FREQUENCY RANGE X100
 FREQUENCY dial 4
 OUTPUT AMPLITUDE 3.0 V
 OUTPUT MONITOR NORMAL

c. Set OUTPUT AMPLITUDE and VERNIER controls for a 3.0 V rms indication on ac voltmeter.

d. Adjust A1R23 for a 3.0 V indication on 652A monitor. If A1R23 does not have sufficient range to properly calibrate monitor, change value of A1R22*. (Increasing A1R22* increases monitor indication and vice versa.)

e. Set 652A FREQUENCY RANGE to X1M, and FREQUENCY dial to 10.

f. Set 652A OUTPUT AMPLITUDE and VERNIER controls for a 3.0 V rms indication on ac voltmeter.

g. Making allowance for any error of the ac voltmeter at 10 MHz, adjust A1C15 for a 3.0 V indication on 652A monitor. If necessary, change value of A2C25*.

NOTE

If ac voltmeter error at 10 MHz is not known, follow this alternative procedure.

h. Perform Steps a through d.

i. Connect equipment as shown in Figure 5-3 and adjust reference supply for null indication on null meter.

j. Set 652A FREQUENCY RANGE to X1M and FREQUENCY dial to 10.

k. Adjust 652A OUTPUT AMPLITUDE and VERNIER controls for null indication on null meter. Do not readjust reference supply.

l. Adjust A1C15 for 3.0 V indication on 652A monitor.

5-41. Expanded Monitor Calibration.

5-42. 10 kHz Monitor Calibration.

a. Set 652A controls as follows:

FREQUENCY RANGEX10K
 FREQUENCY dial 1
 ATTENUATOR 3.0 V
 OUTPUT MONITORNORMAL
 OUTPUT AMPLITUDE
 and VERNIER Adjust for a monitor
 indication of 3.0 V

b. Connect dc voltmeter to A3TP1; voltmeter should indicate $-9\text{ V} \pm 0.2\text{ V}$. If it does not change value of A3C4* and/or A3C8*.

c. Connect dc voltmeter to A3TP2, and vary REF SET controls from minimum to maximum. Voltage at A3TP2 must range from -16.4 V to -18.8 V , with a maximum voltage variation of 3.6 V . If voltage is too high, slightly decrease value of A3R18*. If voltage is too low; slightly increase value of A3R18*.

d. Connect 652A to ac differential voltmeter as shown in Figure 5-9.

e. Adjust 652A AMPLITUDE controls for a 3.000 V indication on differential voltmeter.

f. Set 652A OUTPUT MONITOR to EXPAND, and use REF SET controls to set a zero reference on 652A expanded monitor scale. Do not readjust REF SET controls once reference is obtained.

g. Adjust 652A OUTPUT AMPLITUDE and VERNIER controls for a 3.075 V indication on differential voltmeter. (This is a 2.5% increase in 652A output.) 652A monitor should indicate approximately +2.5% on expand monitor scale (blue scale).

h. Adjust A3R14 for a 652A monitor indication of +2.5%. Repeat Steps e through g until no adjustment is needed.

5-43. 10 MHz Monitor Response Adjustment.

a. Connect thermal converter, dc null meter, and reference supply to 652A as shown in Figure 5-3, setting 652A and reference supply outputs to minimum before connecting.



Do not exceed rated input of thermal converter. Any overload or high voltage transient may destroy thermoelement.

b. Set 652A controls as follows:

FREQUENCY RANGEX10K
 FREQUENCY dial 1
 ATTENUATOR 3.0 V
 OUTPUT MONITORNORMAL

c. Adjust OUTPUT AMPLITUDE AND VERNIER controls for a 652A monitor indication of 3.0 V.

d. Adjust reference supply for a null indication. Do not readjust reference supply once null is obtained.

e. Set 652A OUTPUT MONITOR to EXPAND, and use REF SET controls to set a zero reference on 652A expanded monitor scale.

f. Set 652A FREQUENCY RANGE to X1M, and set FREQUENCY dial to 10.

g. Adjust 652A OUTPUT AMPLITUDE and VERNIER controls for a null indication on null meter.

h. Adjust A3C11 until 652A monitor indicates zero reference set in Step e.

i. Repeat Steps c through h until no further adjustment is needed.

j. Set 652A FREQUENCY dial to 1, and adjust 652A AMPLITUDE controls for a null indication on null meter.

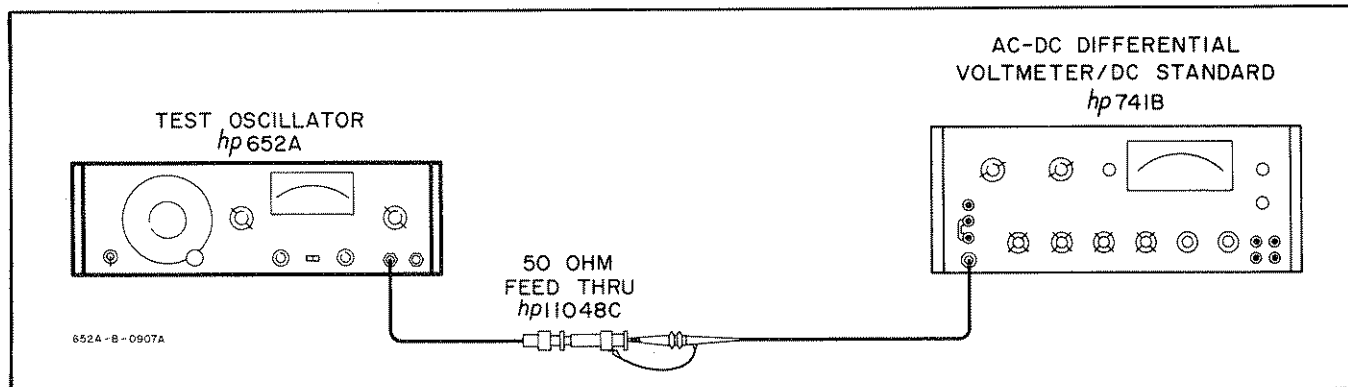

Figure 5-9. 10 kHz Monitor Calibration.

k. Observe 652A monitor indication; if more than $\pm 0.2\%$ from zero reference, change value of A3R1* slightly. Increase the value of A3R1* if the monitor indication is more than $+0.2\%$; decrease the value of A3R1* if the monitor indication is more than -0.2% .

5-44. After Calibration.

5-45. After completing the ADJUSTMENT AND CALIBRATION PROCEDURE, repeat PERFORMANCE TESTS (Paragraphs 5-7 through 5-20) to assure that the 652A is within specifications listed in Table 1-1.

5-46. TROUBLESHOOTING PROCEDURE.

5-47. This section contains information and procedures designed to aid in the process of isolating malfunctions. Troubleshooting should be undertaken only after it has been determined that the malfunction cannot be corrected by performing the adjustment and calibration procedures.

5-48. When a malfunction occurs, first ensure that the trouble is not caused by conditions external to the

instrument, then make the front panel tests shown in Table 5-8. These tests assume that the LINE ON lamp is glowing. If the symptoms outlined are observed, troubleshoot the area indicated; refer to the Troubleshooting Tree (Figure 5-11) and to Paragraph 5-52 for additional information.

5-49. The Troubleshooting Tree in Figure 5-11 illustrates a systematic method of elimination used to locate a faulty circuit or component. The tree does not include specific troubles and problems; it presents a list of key points to be checked for normal circuit indications or conditions, which can be used to eliminate the properly operating circuits from the troubleshooting path. The tests outlined in the troubleshooting tree were not devised to measure all circuit parameters, but to localize the malfunction. Therefore, additional checks and measurements (including visual inspection) will probably be required to completely isolate the faulty component.

5-50. The Block Diagram (Figure 6-1) shows that the instrument can be considered as five basic blocks; the Oscillator Circuit, the Power Amplifier, the Normal Monitor Circuit, the Expand Monitor Circuit and the Regulated

Table 5-8. Front Panel Troubleshooting Tests.
(Set Output Monitor to Normal, Amplitude fully clockwise)

OPERATION	SYMPTOM	PROBABLE TROUBLE AREA
1. Switch OUTPUT ATTENUATOR through all positions	No output at any position of attenuator switch, monitor indicates.	Output Attenuator or A2C22
2. Sweep FREQUENCY dial slowly over its whole range for each position of FREQUENCY RANGE switch	a. Output only on X100K and X1M ranges. b. No output on any one range. c. Output dies at one position of the dial on all ranges. d. Output twice normal level. e. No output or monitor indication on any range or dial setting.	a. A2Q1 b. FREQUENCY RANGE switch and associated components for that range; frequency calibration: c. Tuner capacitor (C1), shorting or frequency calibration. d. Peak Detector circuit (A2Q7) open. e. Proceed to troubleshooting tree.
3. Observe Monitor in both NORMAL and EXPAND positions of the OUTPUT MONITOR switch (Signal must be present at the 50 ohm and 600 ohm jacks.)	a. No indication in NORMAL mode only. b. No indication in EXPAND mode only. c. No indication in both modes.	a. Normal monitor circuit (A1), A2R41 or A2C25*. b. Expand monitor circuit (A3). M1 or S4.
4. Other troubles	a. Dial Accuracy out of spec and/or flatness out of spec b. Incorrect meter indication (particularly at high frequencies)	a. Frequency calibration, Peak Detector A2Q7 or A2CR6 and A2CR7. b. Monitor calibration.

Power Supply. These same five blocks also appear on the troubleshooting tree. To use the tree, decide if ① is true or false, and proceed to the next step along the pertinent branch of the tree. At each step use the additional information given in Paragraph 5-52. Refer to the block diagram in Figure 6-1, and the schematics of Figures 6-2, 6-3 and 6-4, when using the troubleshooting tree.

5-51. Troubleshooting Information.

5-52. This section provides information for each particular step of the troubleshooting tree.

- ① Check the output at both output connectors, and ensure that it is undistorted and within specifications, over the entire frequency range of the instrument.
- ② Check fuse F1 if there is not output and the line indicator lamp does not light; also, ensure that the 115/230 V switch, S5, is in the correct position.
- ③ Check the signal at A2 pin 5 with an oscilloscope.
 - a. The signal should be a sine wave of between 10 V and 12 V peak-to-peak; it should remain essentially constant regardless of the settings of the OUTPUT AMPLITUDE control or the FREQUENCY controls: if true, proceed to branch 11 of the troubleshooting tree.
- ④ False if either (or both) supply is not present.
- ⑤ Check the power supply connections to external circuits.
- ⑥ A procedure for checking the oscillator circuit is given in Paragraph 5-53.
- ⑦ Check the ac input voltages at A1 pin 3 and 5 and A1 pin 6 and 7.

NOTE

The AMPLITUDE VERNIER control will change the level by about 0.2 V, this is normal.

b. If the signal appears when the OUTPUT AMPLITUDE control is fully counterclockwise, but disappears as the control is turned clockwise, then the Power Amplifier is shorting the oscillator signal; proceed to branch 12.

c. If the signal amplitude changes significantly with frequency or if the amplitude is twice normal, then proceed to branch 6.

d. If there is no signal present, check that A2C12 is not open, then proceed to branch 4.

NOTE

Momentary shorting of the + 30 V or - 25 V power supply may cause a Locked Current Limit condition if the power supplies are still loaded by the 652A circuitry. In the Locked Current Limit condition the dc output drops to less than 2 V and does not return to normal when the short is removed. This does not damage the power supplies. Proper power supply voltage can be restored by switching the instrument off and then on again.

- ⑧ If the positive power supply cannot be adjusted to + 30 V, proceed as follows:

- a. Verify that the positive power supply is not in a current limit or foldback current limit condition by disconnecting the power supply load A1 pin 1 (red).

NOTE

The Normal Meter circuit is part of the A1 PC Assembly. To completely unload and isolate the 652A power supplies, lift one end of A1R17(+), and A1R24, A1R26, A1R28 (-).

- b. If the + 30 V power supply is restored by disconnecting one particular load circuit (Oscillator, Output Amplifier, Expand Meter, or Normal Meter), troubleshoot that circuit for shorts or leaky components.

- c. If the + 30 V power supply is not restored by disconnecting the load circuits, troubleshoot the positive power supply. Refer to Figure 6-1 and Figure 6-4.

- ⑨ If the negative power supply cannot be adjusted to - 25 V, proceed as follows:

- a. Verify that the negative power is not in a current limit or foldback current limit condition by disconnecting the power supply load A1 pin 2 (violet).

- b. If the - 25 V power supply is restored by disconnecting one particular load circuit (Oscillator, Output Amplifier, Expand Meter, or Normal Meter), troubleshoot that circuit for shorts or leaky components.

- c. If the - 25 V power supply is not restored by disconnecting the load circuits, troubleshoot the negative power supply. Refer to Figure 6-1 and Figure 6-4.

- ⑩ Check T1 and the line filter components, L1 through L4, C2, C3, C4 and C7. Also, check A1CR1 through A1CR4.

- ⑪ The normal signal at A2 Pin 20, when the 652A output voltage is 3, will be a sine wave of about 16 V peak-to-peak.
- ⑫ A procedure for checking the Power Amplifier is given in Paragraph 5-56.
- ⑬ Check S2R1 through S1R12 if there is no output at either the 50 ohm or 600 ohm connector. Check S2R13 if the output is missing only at the 600 ohm connector. If attenuator is out of specification, tighten mounting screws before checking resistors. If intermittent or noisy, check for poor or dirty switch contacts.
- ⑭ When the 652A output voltage is 3, the normal dc voltage applied at A1 Pin 16 is approximately + 2.7 V. The voltage at A1 Pin 17 should be about .14 V less than that at A1 Pin 16; if not, M1 may be faulty.
- ⑮ The normal signal at A1 Pin 14, when the 652A output voltage is 3, will be a sine wave of 5.8 V rms.
- ⑯ Check the lead to A2 Pin 3, A2R41 and A2C25*.
- ⑰ When the 652A output voltage is 3, the ac signal applied to the rectifier from the collector of A1Q9 is approximately .75 V rms.
- ⑱ Check the dc voltages on A1Q8 and A1Q9 at the points listed below:

Emitter A1Q8	+ 1.8 V
Collector A1Q9	+ 2.5 V
Base A1Q9	- 9.8
Emitter A1Q9	- 10.5

Also check A1C11, A1CR10 and the rectifier diodes A1CR8 and A1CR9.
- ⑲ Check the rectifier diodes A1CR8 through A1CR10, and capacitors A1C12 and A1C13. Also, check A1C11 and A1CR11.
- ⑳ Set the MONITOR to EXPAND, and vary the REF SET controls from minimum to maximum. The voltage at A3 Pin 9 must vary from 0 to at least - .15 V dc.
- ㉑ Disconnect M1 from the circuit, and apply a current of 1.5 mA to check for full scale deflection. Decrease the current, and the pointer deflection of M1 should decrease proportionally.
- ㉒ The normal dc voltage at A3TP1 is - 9 V \pm 0.2 V, when the 652A output voltage is 3. When the AMPLITUDE controls are varied from minimum to maximum, the voltage at A3TP1 should cover a range of approximately - 1.8 V to - 10 V.

- ㉓ Check for .72 V ac at the junction of A3CR1 and A3CR2 and check A3Q1, A3CR1, and A3CR2.
- ㉔ Vary the REF SET controls from minimum to maximum; voltage at A3TP2 must vary from - 16.4 V to - 18.8 V.
- ㉕ Troubleshoot the Variable Reference Supply in the same way as any power supply. Check A3CR6, A3Q7, and A3Q8. If A3Q8 is shorted, A3Q7 will probably also need replacement.
- ㉖ Check the current source, A3Q4 and then check A3Q2, A3Q3, A3Q5, and A3Q6. If these components are good, check A3CR5, A3CR7 and A3CR8.

5-53. Troubleshooting the Oscillator Circuit.

NOTE

This procedure assumes that the front panel checks (Table 5-8) have been made and that the Troubleshooting Tree has been followed (together with the information in Paragraph 5-52) to branch 6.

a. If there is no signal at A2 Pin 5 with the RANGE at X1K and the dial at 1, then switch to X100K. If a signal now appears, then check A2Q1.

b. If the signal at A2 Pin 5 is twice the normal amplitude then the Peak Detector is not operating. In particular check A2Q7 and A2C11.

NOTE

In older instruments (refer to Appendix C, Manual Backdating Changes) also check A2CR5.

c. If there is no signal at A2 Pin 5, isolate the Peak Detector by lifting one side of A2C11 and the emitter of A2Q7. If the oscillator comes on, check the Peak Detector components. If there is no apparent fault in the Peak Detector, it is possible that A2R16 may need to be readjusted. This is likely to occur if only components (such as A2CR6, A2CR&, A2Q2, and A2Q3) have been replaced. To check this reconnect the peak detector and perform Frequency dial and X1K Range Adjustments (Paragraphs 5-29 and 5-30).

d. If the oscillator still cannot be made to operate, perform the procedure of the following paragraph.

5-54. In the following procedure the oscillator circuit is driven by an external signal generator and the Wien Bridge is disabled. This allows the circuit to be checked out using the normal troubleshooting techniques for an amplifier.

5-55. The recommended signal generator is a 652A or 651B (which has 50 ohms output impedance and a frequency range of 10 Hz to 10 MHz). If this is not available, any oscillator with low output impedance and capable of driving up to 3 V rms into approximately 200 ohms will suffice. In most cases it will not be essential to use the generator at frequencies over 1 kHz.

NOTE

Owing to the physical makeup of the FREQUENCY RANGE switch (S1), it is not practical to isolate the components connected between A2 Pin 10 and Section S1C (F) of the range switch; depending on the position of the switch, there will always be an impedance in parallel with the signal generator. On the XIM range this could be as low as 225 ohms.

- a. Turn off the power to the 652A.
- b. Disconnect the Power Amplifier by disconnecting A2 Pin 5.
- c. Disconnect the Peak Detector by lifting one side of A2C11 and the emitter lead of A2Q7.
- d. Disconnect the tuner capacitor (C1) by unscrewing the green wire connected to the underneath of C1.
- e. Disable the RC tuning network of the Wien Bridge by disconnecting A2 Pin 16.
- f. Connect the signal generator with a 10 microfarad non polar capacitor in series to the green wire disconnected from C1, and to the 652A chassis ground. The capacitor blocks any dc present on the signal generator.

NOTE

If a large non polar capacitor is not available, connect two polarized capacitors in series with their + ends connected together.

g. Turn the 652A power on. Set the signal generator frequency to 1 kHz and the output to approximately 2.3 V rms (monitor with an ac voltmeter on the green lead). Monitor the output signal with an oscilloscope on A2 Pin 5.

1. The amplifier has a voltage gain of approximately 2, therefore, the output should be a sine wave of between 10 and 12 volts peak-to-peak.
2. If the signal does not appear at A2 Pin 5, then troubleshoot the amplifier (A2Q1 through A2Q6 and associated circuitry) using normal troubleshooting techniques for an amplifier. A2Q5 and A2Q6 should be replaced as a pair if either has to be replaced.

NOTE

In some instruments A2Q2 and A2Q3 will be different types from those listed in the Parts List (Table 7-1) of this manual. In this case, if either A2Q2 or A2Q3 has to be replaced, then replace both together with the new part number given in this manual. Also, the value of S1C13, S1C15*, A2C21*, A2R16* and A2R24* may have to be changed in accordance with the procedure outlined in the Frequency Calibration Procedure of Paragraph 5-27 and following.*

3. When the amplifier is operating correctly, check the frequency response, which should remain essentially flat between 10 Hz and 10 MHz, by sweeping the signal generator over that range while maintaining a constant input voltage on the green lead.
4. Reconnect A2C11 and A2Q7 to ensure that the Peak Detector does not disable the amplifier (if it does, troubleshoot the Peak Detector). If the signal is still present at A2 Pin 5, then the probable cause of trouble in the oscillator circuit is the FREQUENCY RANGE switch or associated components.

5-56. Troubleshooting the Power Amplifier.

a. Disconnect the lead (white/orange/green) from A2 Pin 4 and connect the signal generator (recommended in Paragraph 5-55) to A2 Pin 4 (the dc blocking capacitor is not necessary).

b. Observe the output, if any, at A2 Pin 20, the amplifier should have a voltage gain of approximately 1.3. Check the frequency response over the frequency range of 10 Hz to 10 MHz. This should remain essentially constant.

c. If there is not output at A2 Pin 20, then troubleshoot the amplifier (A2Q8 through A2Q12) using normal troubleshooting techniques for an amplifier. If A2C19 is shorted, then both A2Q11 and A2Q12 will be destroyed.

5-57. Troubleshooting the Attenuator.

a. If the output is radically out of specification in one or more attenuator positions, then check the attenuator resistors.

b. If only slightly out of specification in the lower positions, - 40 dBm and below, then suspect the attenuator grounding. Tighten all shield screws, output jacks and the main nut on the attenuator assembly. Make sure that the internal metal shields are visible on the outside metal cover of the attenuator. Tap firmly on the attenuator shield with a screwdriver handle to improve grounding.

5-58. SERVICING ETCHED CIRCUIT BOARDS.

5-59. The Model 652A contains three plated-through, double-sided, etched circuit boards. When working on these boards, observe the following rules to prevent damage to the circuit board or components:

a. Use a low-heat (25 to 50 watts) soldering iron with a small tip.

b. To remove a component, clip a heat sink (long nose pliers, commercial heat sink tweezers, etc.) on the component leads as close to the component as possible. Place the soldering iron directly on the component lead, and pull up on the lead. If a component is obviously damaged or faulty, clip the leads close to the component, and remove the leads from the board.



Excessive or prolonged heat can lift the circuit foil from the board or cause damage to components.

c. Clean the component lead holes by heating the solder in the hole, quickly removing the soldering iron, and inserting a pointed, non-metallic object such as a toothpick.

d. To mount a new component, shape the leads and insert them in the holes. Clip a heat sink on the component, heat with the soldering iron, and add solder as necessary to obtain a good electrical connection.

5-60. SERVICING ROTARY SWITCHES.

5-61. The Model 652A contains two rotary type switches: FREQUENCY RANGE and OUTPUT ATTENUATOR.

When working on these switches, observe the following rules:

a. Use a low heat (25 to 50 watts) soldering iron with a small tip.

b. When replacing components, attempt to dress them as nearly to their original alignment as possible.

c. Clean excessive flux from the connection and adjoining area.

d. After cleaning the switch, apply a light coat of lubricate to the switch detent balls. DO NOT apply lubricant to switch contacts or allow lubricant to contaminate components.

e. To eliminate excessive contact wear and oxidation, the contacts may be lubricated with Electrolube 2G, -hp- Part No. 5060-6086. Only a very small amount of lubricant is necessary. Note: Electrolube 2G will change to a reddish brown color with time; however, the lubricating properties are not affected. A more detailed description on how to apply Electrolube 2G is available at no cost from your local Sales and Service Office. Ask for Service Note M45.

5-62. SERVICING TUNER ASSEMBLY.

5-63. When replacing the tuning capacitor, C1, make certain that the tuner coupler and the frequency dial shaft are aligned to prevent binding of the FREQUENCY dial or VERNIER control. If necessary, remove the frequency dial knob, frequency dial, and loosen the tuner drive assembly (casting and spur gears) retaining screws; then align tuner coupler and frequency dial shaft. Tighten retaining screws after tuner coupler and dial shaft are aligned.

NOTE

For correct alignment, refer to Frequency Dial Calibration, Paragraph 5-29.

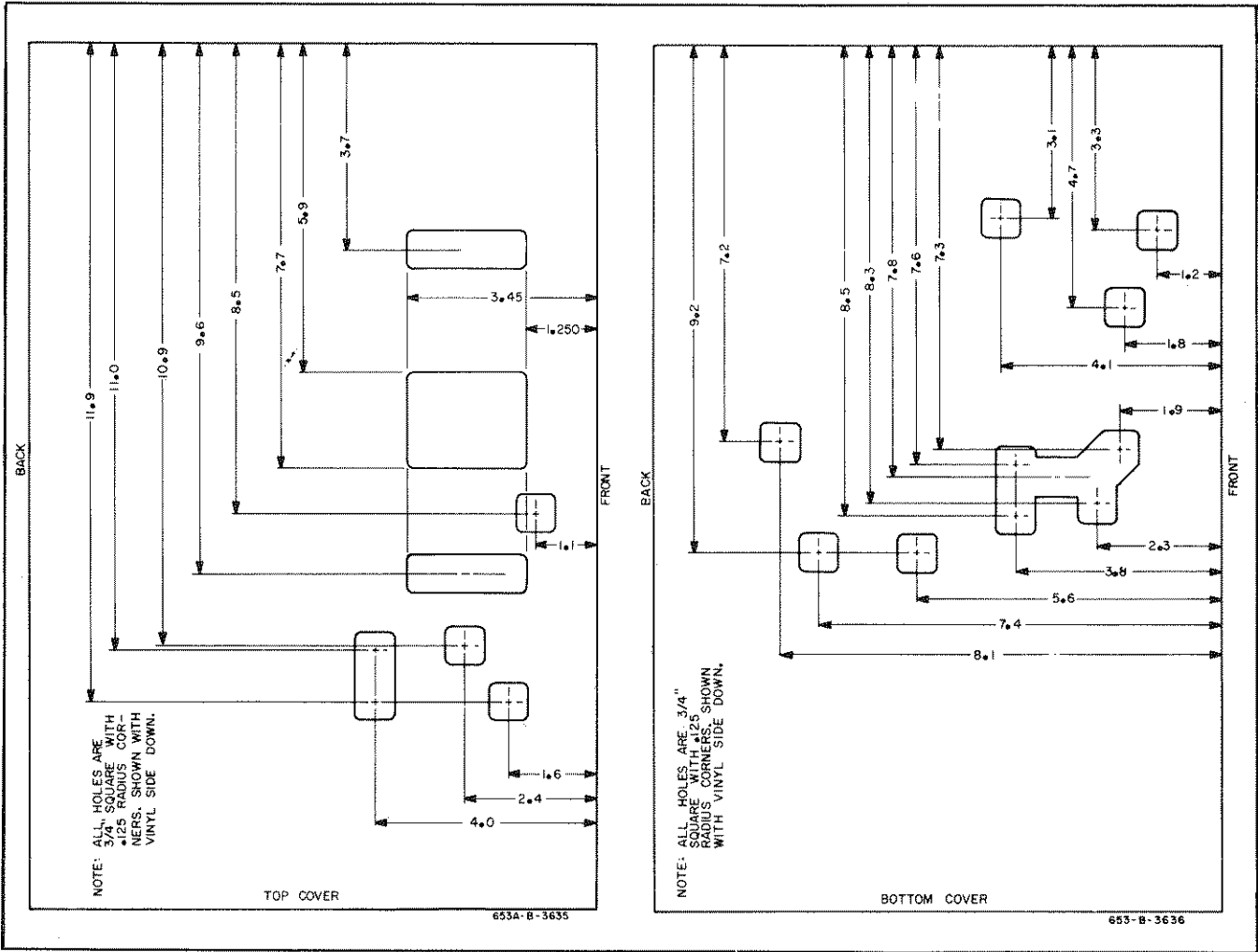

Figure 5-10. Alignment Access Covers for Models 651B, 2A, 3A, 4A.

NOTE

When using the troubleshooting tree, set the 652A controls as follows, unless stated otherwise for a particular step:

FREQUENCY RANGE X1K
 FREQUENCY Dial 5
 OUTPUT ATTENUATOR 3.0V
 OUTPUT MONITOR NORMAL
 OUTPUT AMPLITUDE and VERNIER controls Adjust for an RMS voltmeter indication of 3V (use test setup shown in Figure 5-2)

A tolerance of +/- 10% should be allowed for all voltages given in the troubleshooting tree, unless stated otherwise. Refer to Paragraph 5-52 at each step of the tree.

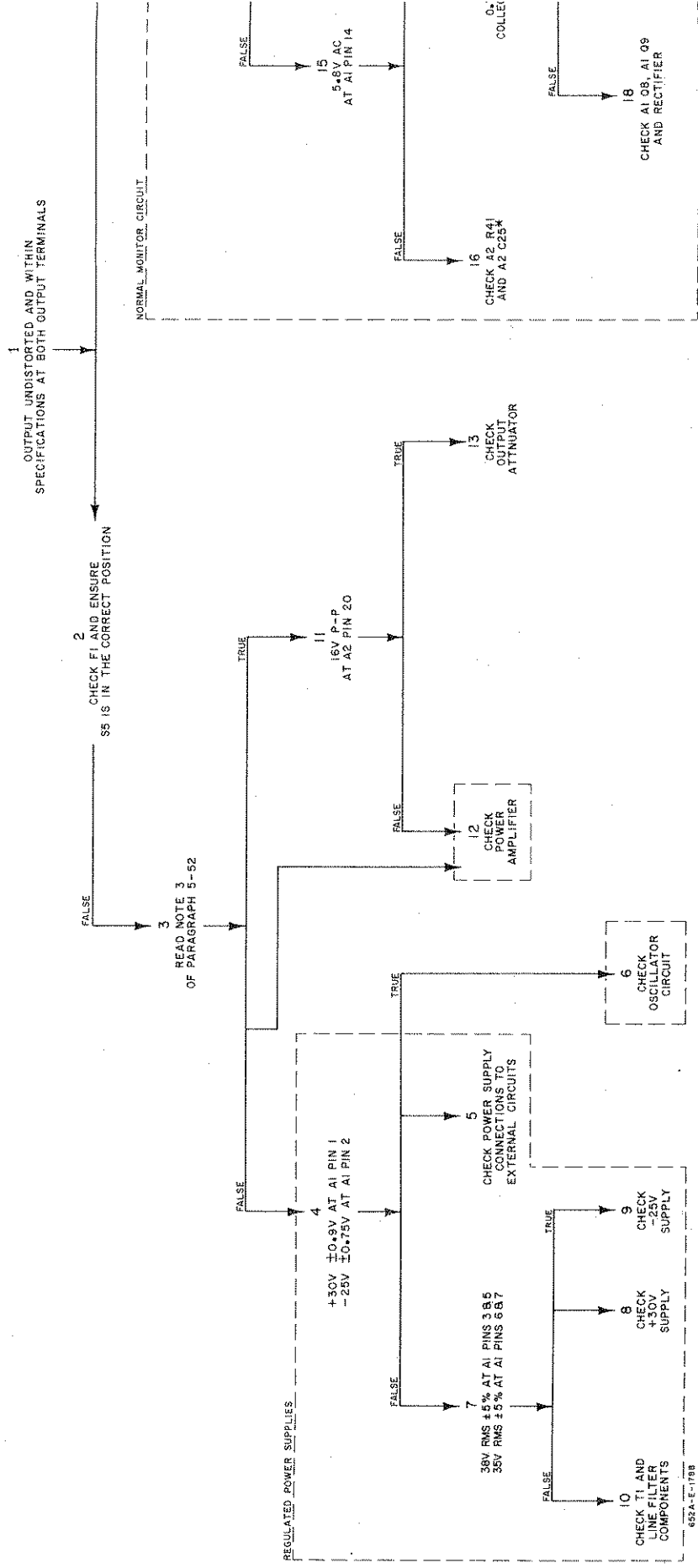

INALS

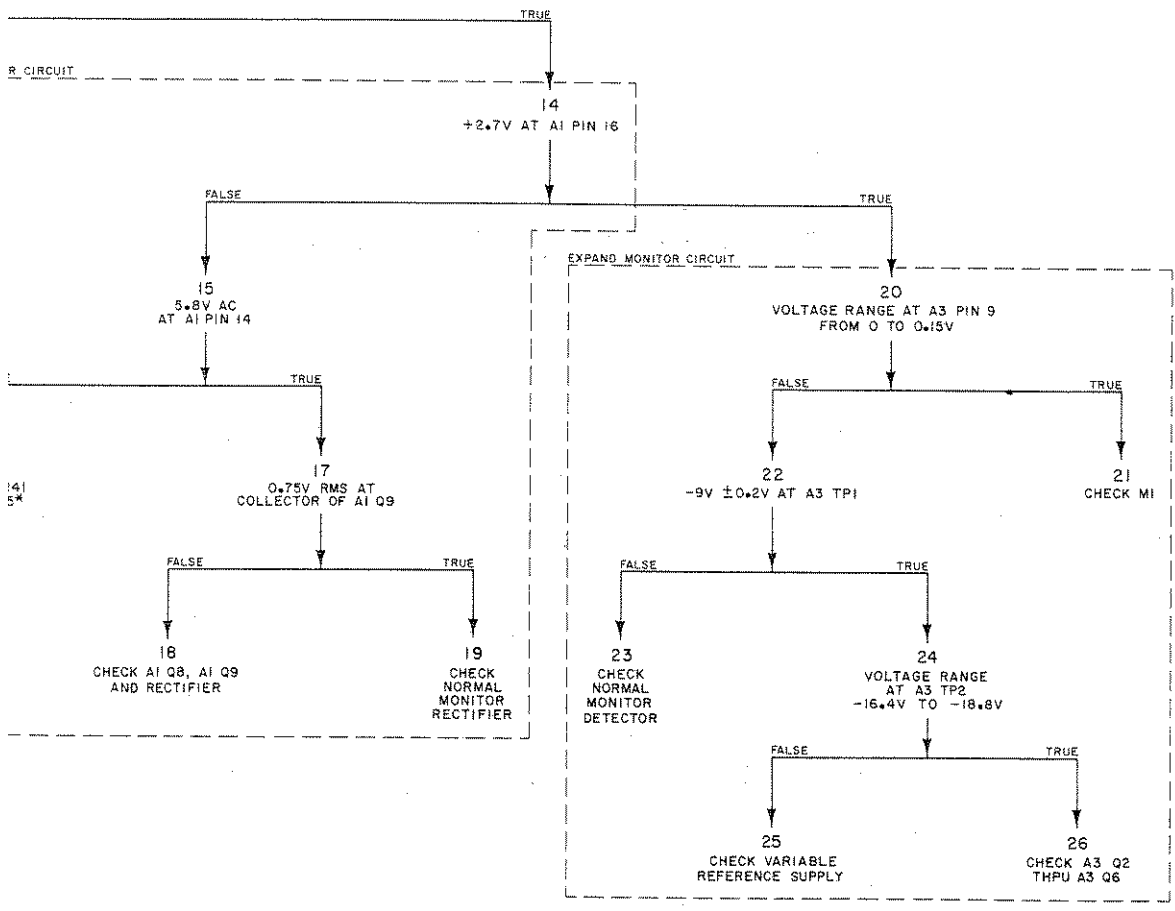

Figure 5-11. Troubleshooting Tree.
5-23/5-24

PERFORMANCE CHECK TEST CARD

Hewlett-Packard Model 652A
 Test Oscillator
 Serial No. _____

Tests Performed by _____
 Date _____

5-7. FREQUENCY RANGE:		Period/Frequency	
Freq. Range	Dial Settings	Min.	Max.
X10	Clockwise	(100 ms)	---
X1M	Counterclockwise	10 MHz	---

5-8. DIAL ACCURACY:		Period/Frequency	
Freq. Range	Dial Settings	Min.	Max.
X10	1	(97 ms)	(103 ms)
X10	5	(19.4 ms)	(20.6 ms)
X10	10	(9.7 ms)	(10.3 ms)
X100	1	(9.8 ms)	(10.2 ms)
X100	5	(1.96 ms)	(2.04 ms)
X100	10	(0.98 ms)	(1.02 ms)
X1K	1	0.98 kHz	1.02 kHz
X1K	5	4.9 kHz	5.0 kHz
X1K	10	9.8 kHz	10.2 kHz
X10K	1	9.8 kHz	10.2 kHz
X10K	5	49.0 kHz	51.0 kHz
X10K	10	98.0 kHz	102.0 kHz
X100K	1	98.0 kHz	102.0 kHz
X100K	5	490.0 kHz	510.0 kHz
X100K	10	980.0 kHz	1020.0 kHz
X1M	1	0.97 MHz	1.03 MHz
X1M	5	4.85 MHz	5.15 MHz
X1M	10	9.70 MHz	10.30 MHz

5-9. OUTPUT:	Min.	Max.
5-10. Maximum Voltage - 50 ohm output	3.16 V	---
600 ohm output	3.16 V	---
5-11. Flatness (Amplitude not readjusted to a reference on the output monitor)		
Freq. Range		
100 Hz to 1 MHz	---	+/- 2%
10 Hz to 1 MHz	---	+/- 3%
10 Hz to 10 MHz	---	+/- 4%
5-12. Flatness (Amplitude readjusted to a reference on the normal output monitor)		
Freq. Range		
10 Hz to 20 Hz	---	2%
20 Hz to 4 MHz	---	1%
4 MHz to 10 MHz	---	2%

PERFORMANCE CHECK TEST CARD (Cont'd)

<p>5-13. Flatness (Amplitude readjusted to a reference on expanded output monitor)</p> <p align="center">Freq. Range</p> <p align="center">10 Hz to 10 MHz</p>	<table border="0"> <tr> <td align="center">Min.</td> <td align="center">_____</td> <td align="center">Max.</td> </tr> <tr> <td align="center">---</td> <td align="center">_____</td> <td align="center">+/- 0.25%</td> </tr> </table>	Min.	_____	Max.	---	_____	+/- 0.25%																																																						
Min.	_____	Max.																																																											
---	_____	+/- 0.25%																																																											
<p>5-14. OUTPUT MONITOR ACCURACY:</p>	<table border="0"> <tr> <td align="center">Min.</td> <td align="center">_____</td> <td align="center">Max.</td> </tr> <tr> <td align="center">2.94 V</td> <td align="center">_____</td> <td align="center">3.06 V</td> </tr> </table>	Min.	_____	Max.	2.94 V	_____	3.06 V																																																						
Min.	_____	Max.																																																											
2.94 V	_____	3.06 V																																																											
<p>5-15. ATTENUATOR: 652A Attenuator</p> <table border="0"> <tr> <td align="center">+20 dB</td> <td align="center">8.91 mV to 9.09 mV</td> <td align="center">1 kHz</td> <td align="center">_____</td> </tr> <tr> <td align="center">+10 dB</td> <td align="center">8.91 mV to 9.09 mV</td> <td align="center">10 MHz</td> <td align="center">_____</td> </tr> <tr> <td align="center">0 dB</td> <td align="center">8.91 mV to 9.09 mV</td> <td></td> <td align="center">_____</td> </tr> <tr> <td align="center">-10 dB</td> <td align="center">8.91 mV to 9.09 mV</td> <td></td> <td align="center">_____</td> </tr> <tr> <td align="center">-20 dB</td> <td align="center">8.91 mV to 9.09 mV</td> <td></td> <td align="center">_____</td> </tr> <tr> <td align="center">-30 dB</td> <td align="center">8.91 mV to 9.09 mV</td> <td></td> <td align="center">_____</td> </tr> <tr> <td align="center">-40 dB</td> <td align="center">8.91 mV to 9.09 mV</td> <td></td> <td align="center">_____</td> </tr> <tr> <td align="center">-50 dB</td> <td align="center">8.91 mV to 9.09 mV</td> <td></td> <td align="center">_____</td> </tr> <tr> <td align="center">-60 dB</td> <td align="center">8.91 mV to 9.09 mV</td> <td></td> <td align="center">_____</td> </tr> <tr> <td align="center">-70 dB</td> <td align="center">8.82 mV to 9.18 mV</td> <td></td> <td align="center">_____</td> </tr> </table>	+20 dB	8.91 mV to 9.09 mV	1 kHz	_____	+10 dB	8.91 mV to 9.09 mV	10 MHz	_____	0 dB	8.91 mV to 9.09 mV		_____	-10 dB	8.91 mV to 9.09 mV		_____	-20 dB	8.91 mV to 9.09 mV		_____	-30 dB	8.91 mV to 9.09 mV		_____	-40 dB	8.91 mV to 9.09 mV		_____	-50 dB	8.91 mV to 9.09 mV		_____	-60 dB	8.91 mV to 9.09 mV		_____	-70 dB	8.82 mV to 9.18 mV		_____	<table border="0"> <tr> <td align="center" colspan="2">DC Voltmeter</td> <td align="center" colspan="2">Frequency</td> </tr> <tr> <td></td> <td></td> <td align="center">1 kHz</td> <td align="center">10 MHz</td> </tr> </table>	DC Voltmeter		Frequency				1 kHz	10 MHz												
+20 dB	8.91 mV to 9.09 mV	1 kHz	_____																																																										
+10 dB	8.91 mV to 9.09 mV	10 MHz	_____																																																										
0 dB	8.91 mV to 9.09 mV		_____																																																										
-10 dB	8.91 mV to 9.09 mV		_____																																																										
-20 dB	8.91 mV to 9.09 mV		_____																																																										
-30 dB	8.91 mV to 9.09 mV		_____																																																										
-40 dB	8.91 mV to 9.09 mV		_____																																																										
-50 dB	8.91 mV to 9.09 mV		_____																																																										
-60 dB	8.91 mV to 9.09 mV		_____																																																										
-70 dB	8.82 mV to 9.18 mV		_____																																																										
DC Voltmeter		Frequency																																																											
		1 kHz	10 MHz																																																										
<p>5-16. AMPLITUDE CONTROL:</p>	<table border="0"> <tr> <td align="center" colspan="2">AC Voltmeter</td> </tr> <tr> <td align="center">greater than -20 dB</td> <td align="center">_____</td> </tr> </table>	AC Voltmeter		greater than -20 dB	_____																																																								
AC Voltmeter																																																													
greater than -20 dB	_____																																																												
<p>5-17. DISTORTION:</p> <table border="0"> <tr> <td align="center">Freq. Range</td> <td align="center">Dial Setting</td> <td align="center">Distortion Meter</td> <td></td> </tr> <tr> <td align="center">X10</td> <td align="center">1</td> <td align="center">less than 1%</td> <td align="center">_____</td> </tr> <tr> <td align="center">X100</td> <td align="center">1</td> <td align="center">less than 1%</td> <td align="center">_____</td> </tr> <tr> <td align="center">X1K</td> <td align="center">1</td> <td align="center">less than 1%</td> <td align="center">_____</td> </tr> <tr> <td align="center">X10K</td> <td align="center">1</td> <td align="center">less than 1%</td> <td align="center">_____</td> </tr> <tr> <td align="center">X100K</td> <td align="center">1</td> <td align="center">less than 1%</td> <td align="center">_____</td> </tr> <tr> <td align="center">X100K</td> <td align="center">5</td> <td align="center">less than 1%</td> <td align="center">_____</td> </tr> <tr> <td align="center">X1M</td> <td align="center">2</td> <td align="center">less than 1%</td> <td align="center">_____</td> </tr> <tr> <td align="center">X1M</td> <td align="center">5</td> <td align="center">less than 2%</td> <td align="center">_____</td> </tr> <tr> <td align="center">X1M</td> <td align="center">10</td> <td align="center">less than 4%</td> <td align="center">_____</td> </tr> </table>	Freq. Range	Dial Setting	Distortion Meter		X10	1	less than 1%	_____	X100	1	less than 1%	_____	X1K	1	less than 1%	_____	X10K	1	less than 1%	_____	X100K	1	less than 1%	_____	X100K	5	less than 1%	_____	X1M	2	less than 1%	_____	X1M	5	less than 2%	_____	X1M	10	less than 4%	_____	<table border="0"> <tr> <td align="center">Distortion Meter</td> <td></td> </tr> <tr> <td align="center">less than 1%</td> <td align="center">_____</td> </tr> <tr> <td align="center">less than 1%</td> <td align="center">_____</td> </tr> <tr> <td align="center">less than 1%</td> <td align="center">_____</td> </tr> <tr> <td align="center">less than 1%</td> <td align="center">_____</td> </tr> <tr> <td align="center">less than 1%</td> <td align="center">_____</td> </tr> <tr> <td align="center">less than 1%</td> <td align="center">_____</td> </tr> <tr> <td align="center">less than 1%</td> <td align="center">_____</td> </tr> <tr> <td align="center">less than 2%</td> <td align="center">_____</td> </tr> <tr> <td align="center">less than 4%</td> <td align="center">_____</td> </tr> </table>	Distortion Meter		less than 1%	_____	less than 1%	_____	less than 1%	_____	less than 1%	_____	less than 1%	_____	less than 1%	_____	less than 1%	_____	less than 2%	_____	less than 4%	_____
Freq. Range	Dial Setting	Distortion Meter																																																											
X10	1	less than 1%	_____																																																										
X100	1	less than 1%	_____																																																										
X1K	1	less than 1%	_____																																																										
X10K	1	less than 1%	_____																																																										
X100K	1	less than 1%	_____																																																										
X100K	5	less than 1%	_____																																																										
X1M	2	less than 1%	_____																																																										
X1M	5	less than 2%	_____																																																										
X1M	10	less than 4%	_____																																																										
Distortion Meter																																																													
less than 1%	_____																																																												
less than 1%	_____																																																												
less than 1%	_____																																																												
less than 1%	_____																																																												
less than 1%	_____																																																												
less than 1%	_____																																																												
less than 1%	_____																																																												
less than 2%	_____																																																												
less than 4%	_____																																																												
<p>5-18. HUM AND NOISE:</p>	<table border="0"> <tr> <td align="center" colspan="2">AC Voltmeter</td> </tr> <tr> <td align="center">greater than -66 dB</td> <td align="center">_____</td> </tr> </table>	AC Voltmeter		greater than -66 dB	_____																																																								
AC Voltmeter																																																													
greater than -66 dB	_____																																																												
<p>5-19. AMPLITUDE STABILITY:</p>	<table border="0"> <tr> <td align="center">2% per month (20° C - 30° C)</td> <td align="center">_____</td> </tr> </table>	2% per month (20° C - 30° C)	_____																																																										
2% per month (20° C - 30° C)	_____																																																												
<p>5-20. OUTPUT IMPEDANCE:</p> <table border="0"> <tr> <td align="center">50 ohm output</td> <td align="center">45 ohms</td> <td align="center">_____</td> <td align="center">55 ohms</td> </tr> <tr> <td align="center">600 ohm output</td> <td align="center">540 ohms</td> <td align="center">_____</td> <td align="center">660 ohms</td> </tr> </table>	50 ohm output	45 ohms	_____	55 ohms	600 ohm output	540 ohms	_____	660 ohms	<table border="0"> <tr> <td align="center">Min.</td> <td align="center">_____</td> <td align="center">Max.</td> </tr> <tr> <td align="center">45 ohms</td> <td align="center">_____</td> <td align="center">55 ohms</td> </tr> <tr> <td align="center">540 ohms</td> <td align="center">_____</td> <td align="center">660 ohms</td> </tr> </table>	Min.	_____	Max.	45 ohms	_____	55 ohms	540 ohms	_____	660 ohms																																											
50 ohm output	45 ohms	_____	55 ohms																																																										
600 ohm output	540 ohms	_____	660 ohms																																																										
Min.	_____	Max.																																																											
45 ohms	_____	55 ohms																																																											
540 ohms	_____	660 ohms																																																											

SECTION VI

CIRCUIT DIAGRAMS

6-1. INTRODUCTION.

6-2. This section contains the circuit diagrams necessary for operation and maintenance of the Model 652A. Figure 6-1 is a block diagram which shows the overall relationship between the basic circuits of the instrument. Figures 6-2

through 6-4 contain the detailed schematic diagrams as well as component location drawings of each printed circuit board and the two rotary switches.

6-3. An explanation of terms and symbols used as reference designators is given below.

REFERENCE DESIGNATIONS

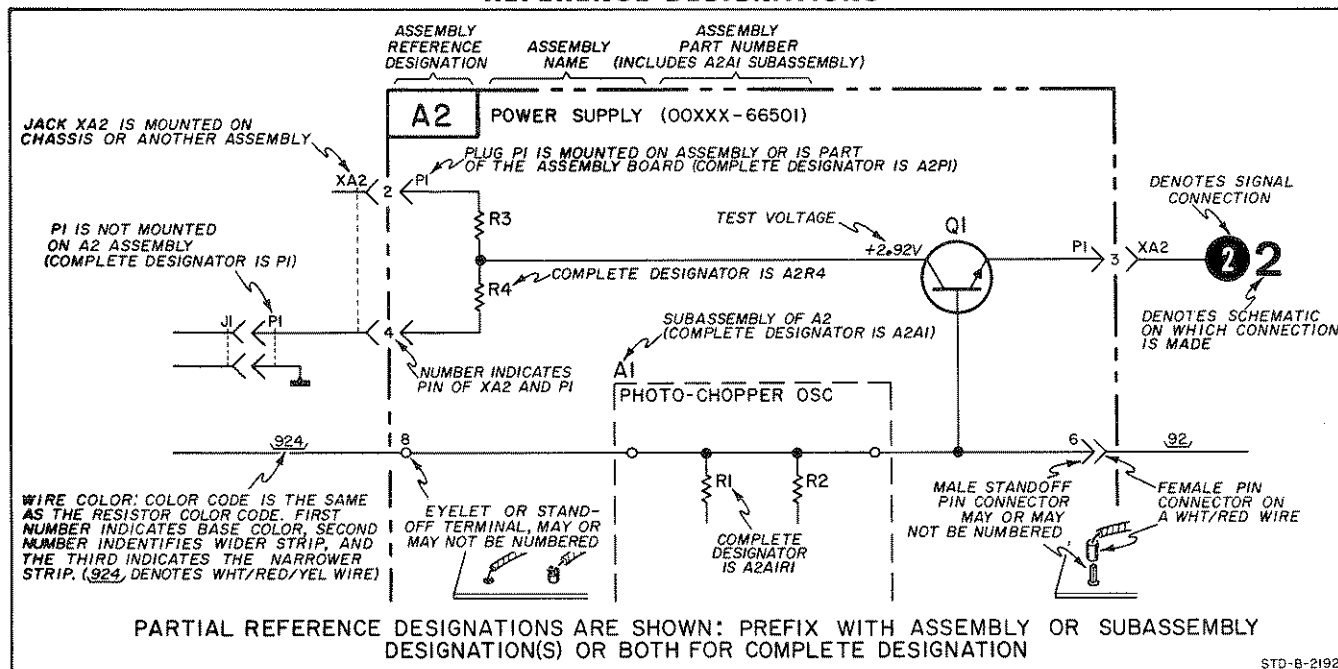

STD-B-2192

NOTES

- | | |
|--|---|
| <ol style="list-style-type: none"> 1. PARTIAL REFERENCE DESIGNATIONS ARE SHOWN. PREFIX WITH ASSEMBLY OR SUBASSEMBLY DESIGNATION(S) OR BOTH FOR COMPLETE DESIGNATION. 2. COMPONENT VALUES ARE SHOWN AS FOLLOWS UNLESS OTHERWISE NOTED.

RESISTANCE IN OHMS
CAPACITANCE IN MICROFARADS 3. DENOTES ASSEMBLY. 4. DENOTES MAIN SIGNAL PATH. 5. DENOTES FEEDBACK PATH. 6. DENOTES FRONT PANEL MARKING. 7. DENOTES SCREWDRIVER ADJUST. 8. DENOTES FRONT PANEL CONTROL. | <ol style="list-style-type: none"> 9. DENOTES POWER LINE GROUND. 10. DENOTES CHASSIS GROUND. 11. DENOTES CIRCUIT GROUND. (ASSEMBLY) 12. * AVERAGE VALUE SHOWN, OPTIMUM VALUE SELECTED AT FACTORY. COMPONENT MAY BE ABSENT. 13. DENOTES GROUND CONNECTION MADE WITH ASSEMBLY MOUNTING SCREWS IN PLACE. 14. DENOTES SHIELDING BEAD. 15. REFERENCE DESIGNATORS PRINTED IN RED INDICATE BACKDATING CHANGES (SEE APPENDIX C). 16. DENOTES WIRE COLOR. CODE IS SAME AS THE RESISTOR COLOR CODE (i. e., 9 = white, 8 = gray, 4 = yellow). |
|--|---|

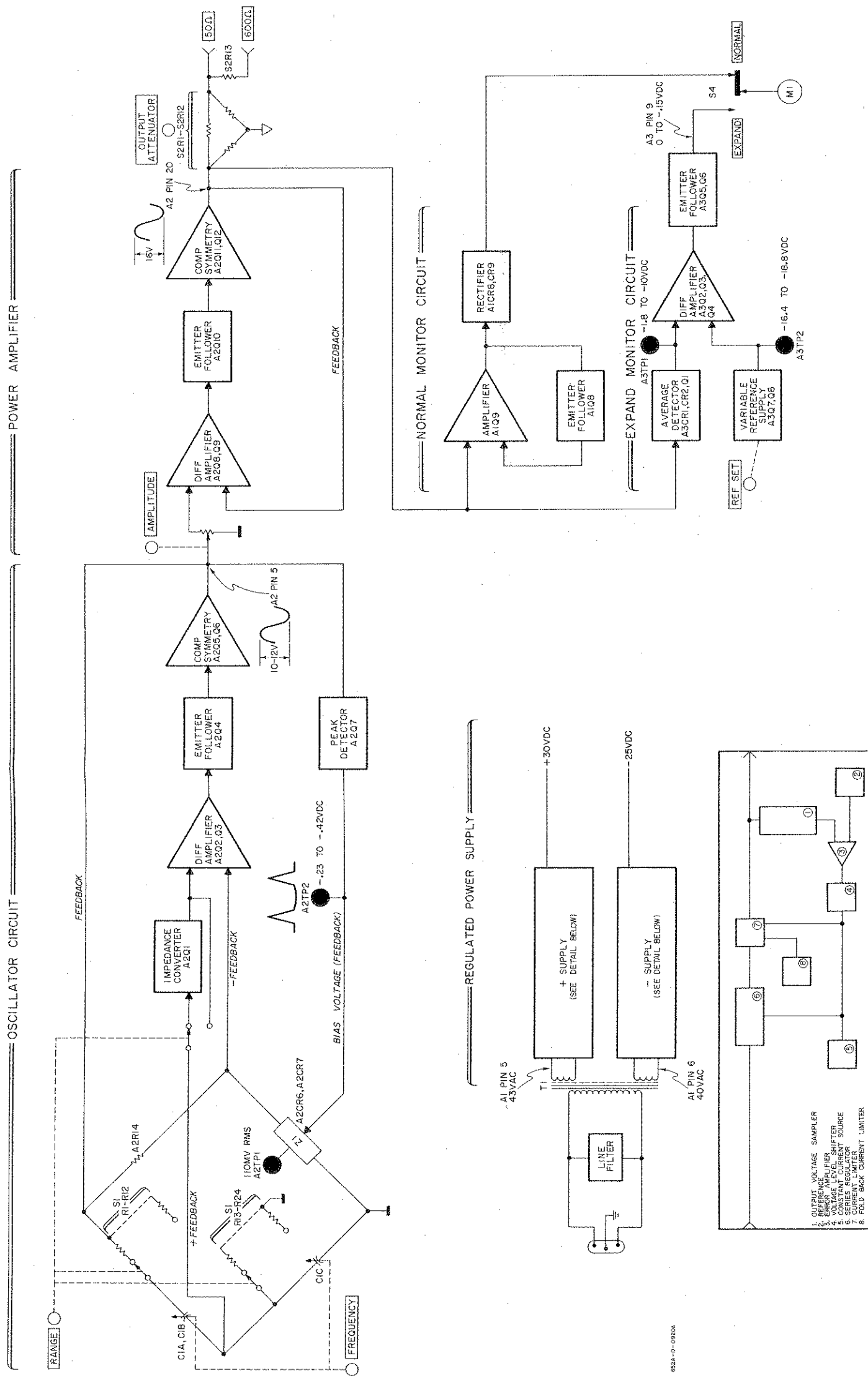
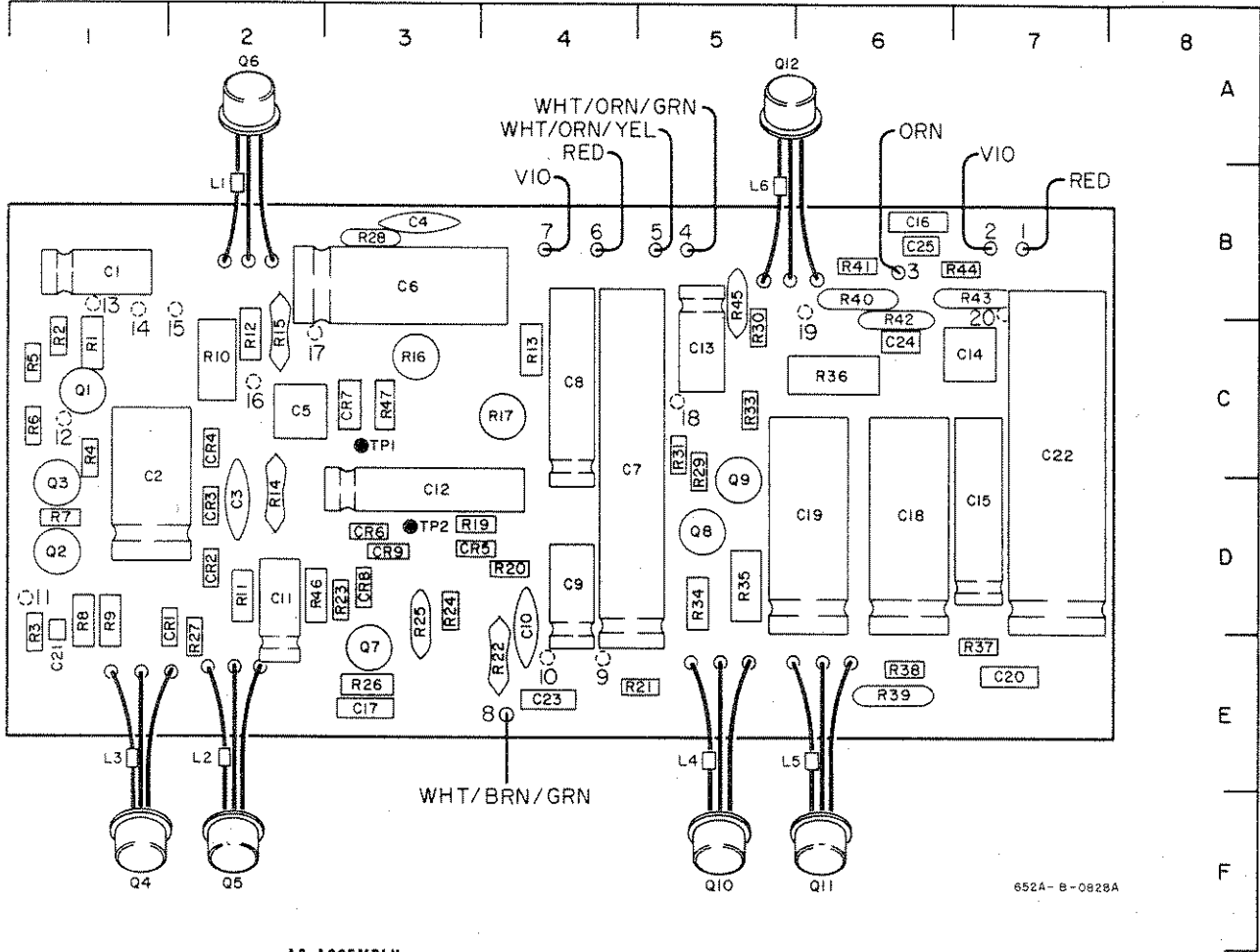

Figure 6-1. Block Diagram.

A2 ASSEMBLY



A2 ASSEMBLY
COMPONENT LOCATIONS

	C	CR	L	Q	R		R
1	B1	D2	B2	C1	C1	26	E3
2	C1	D2	E2	D1	C1	27	E2
3	D2	D2	F1	D1	E1	28	B3
4	B3	C2	E5	F1	C1	29	C5
5	C2	D3	E6	F2	C1	30	C5
6	B3	D3	B5	A2	C1	31	C5
7	C4	C3		E3	D1	32	---
8	C4	D3		D5	D1	33	C5
9	D4	D3		D5	D1	34	D5
10	D4			F5	C2	35	D5
11	D2			F6	D2	36	C6
12	D3			A5	C2	37	E7
13	C5				C4	38	E6
14	C7				D2	39	E6
15	D7				C2	40	B6
16	B6				C3	41	B6
17	E3				C3	42	B6
18	D6				C3	43	B7
19	D6				D3	44	B7
20	E7				D4	45	B5
21	E1				E5	46	D2
22	C7				E4		
23	E4				D3		
24	C6				D3		
25	B6				D3		

A2 ASSEMBLY WIRE COLORS
(BOTTOM)

PIN NO.	WIRE COLOR
9	WHITE
10	BLACK
11	WHT/ORN
12	BLACK
13	ORANGE
14	WHT/GRN
15	RED
16	WHT/YEL
17	BLACK
18	WHT/BLK
19	BLUE
20	

SI
RANGE

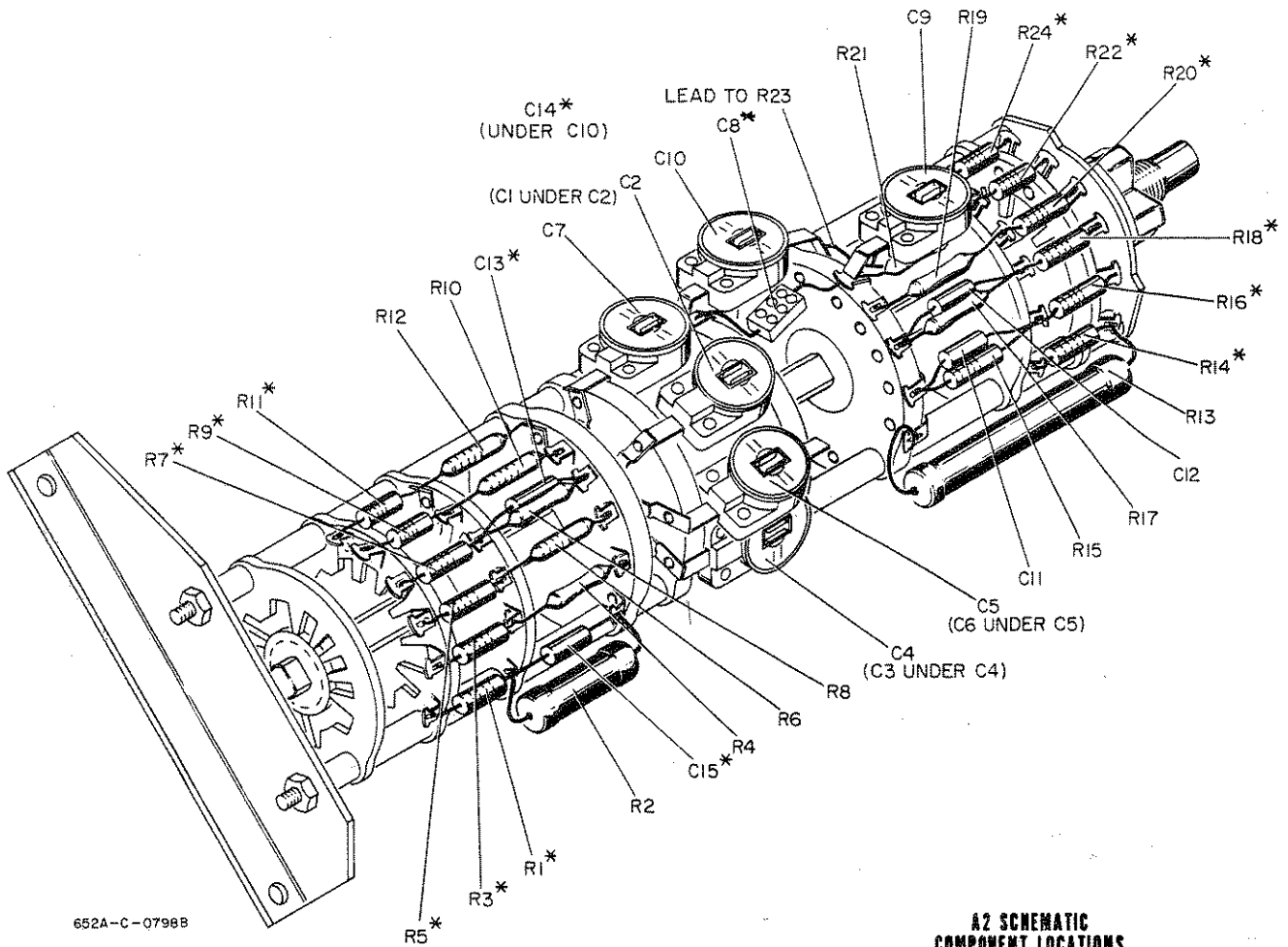

A2 SCHEMATIC
COMPONENT LOCATIONS

	C	CR	L	Q	R		R
1	H14	E15	G16	F12	F11	26	C18
2	D13	F15	E16	F14	G12	27	D16
3	F16	F15	D15	G14	J15	28	H16
4	J16	G15	D21	E15	G14	29	F20
5	F8	F17	E22	F16	H14	30	H19
6	F7	H8	G22	G16	H14	31	C20
7	J8	H7		F18	F14	32	---
8	J9	F18		F20	D14	33	G20
9	J7	F17		G20	D14	34	D20
10	J8			E21	H15	35	F21
11	G17			F22	F16	36	H21
12	C16			G22	G16	37	C23
13	C17				J12	38	F22
14	J22				D7	39	F23
15	J23				E7	40	G23
16	H19				F7	41	G23
17	D19				G7	42	G23
18	G22				G7	43	J23
19	F22				H10	44	H23
20	D23				H8	45	H22
21	D14				J8	46	E18
22	F23				H17		
23	J17				G17		
24	G23				G17		
25	G24				H17		

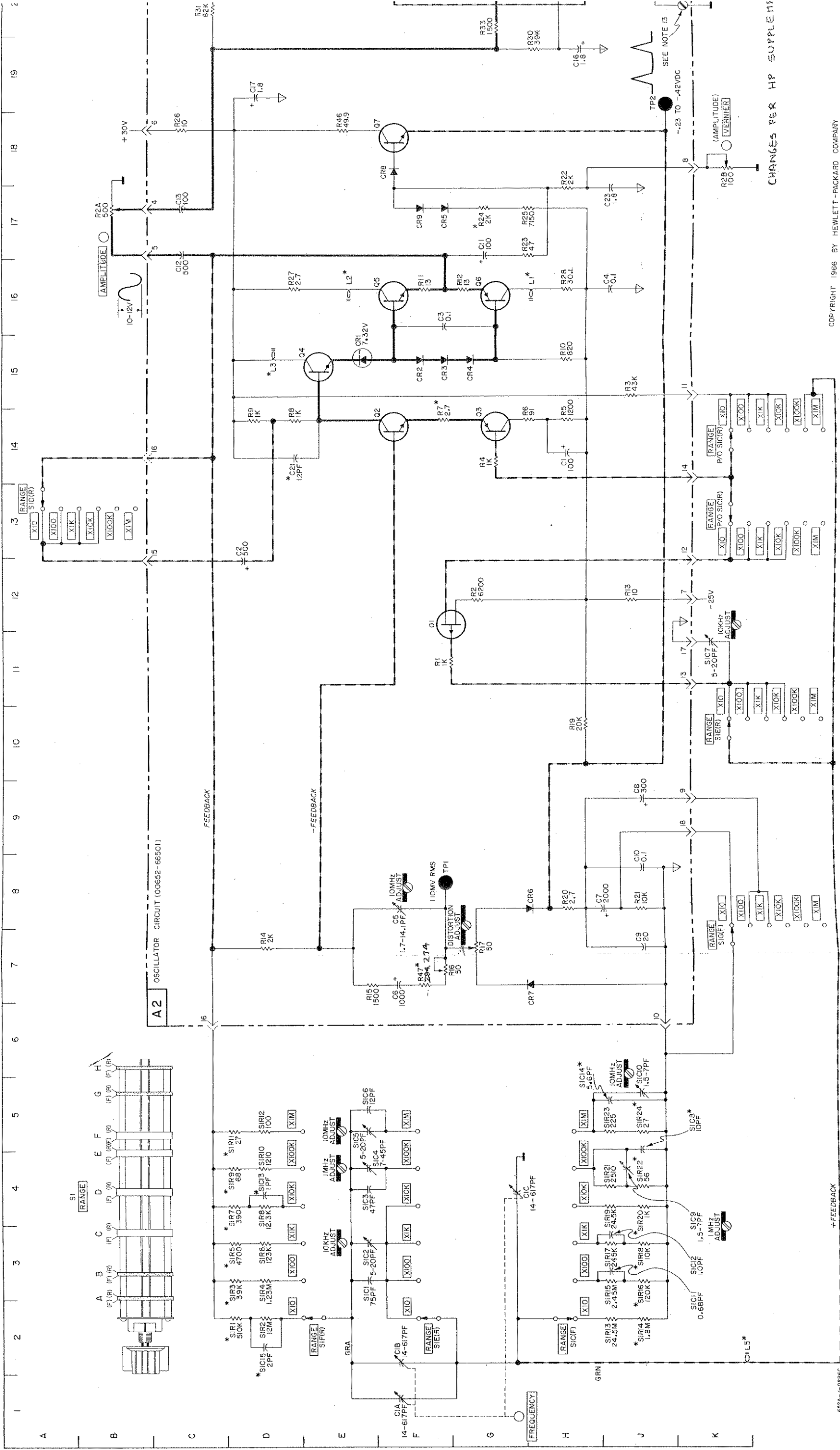

652A-J-0886C

652A-J-0886C

652A-J-0886C

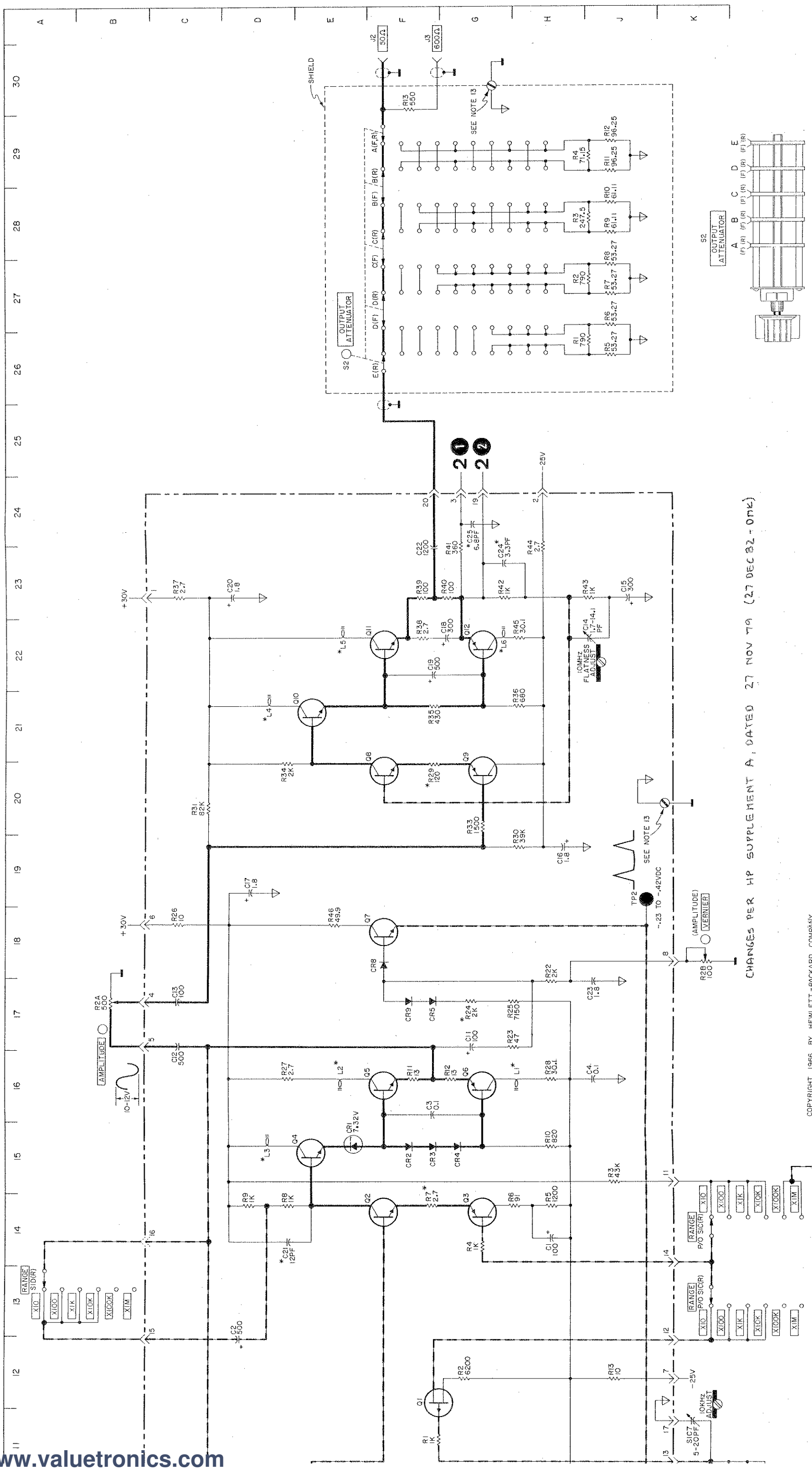

CHANGES PER HP SUPPLEMENT A, DATED 27 NOV 79 (27 DEC 82 - 0mk)

COPYRIGHT 1966 BY HEWLETT-PACKARD COMPANY

Figure 6-2. Oscillator Circuit.
6-5/6-6

AI ASSEMBLY

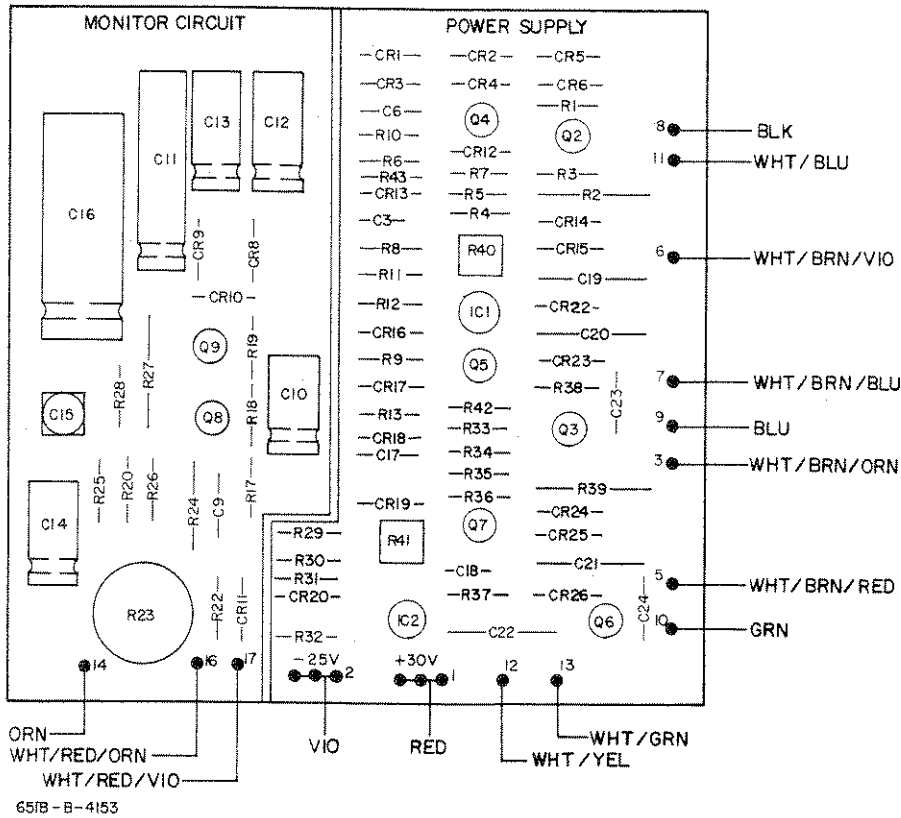

A3 ASSEMBLY

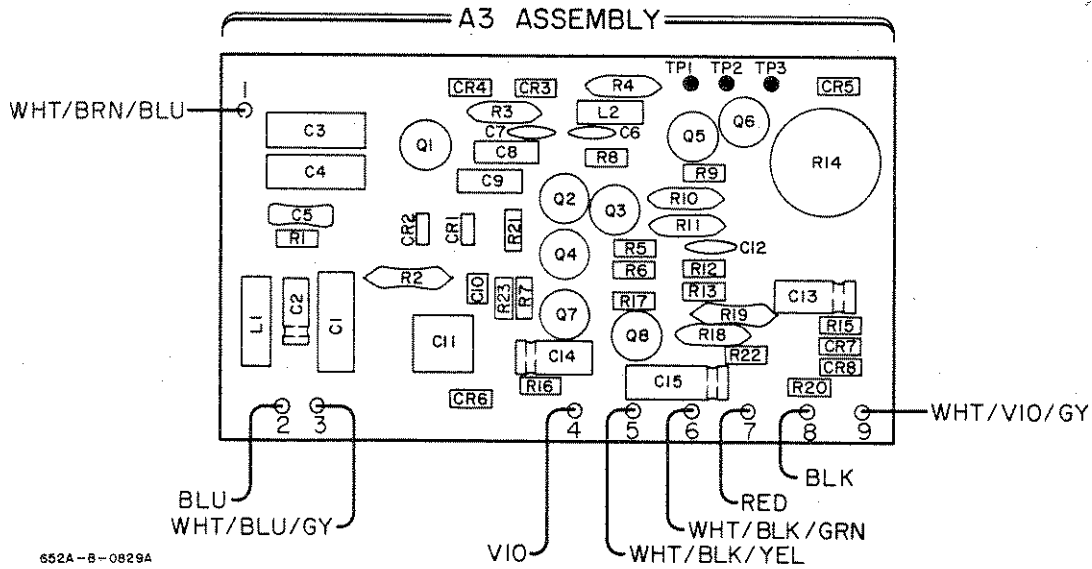

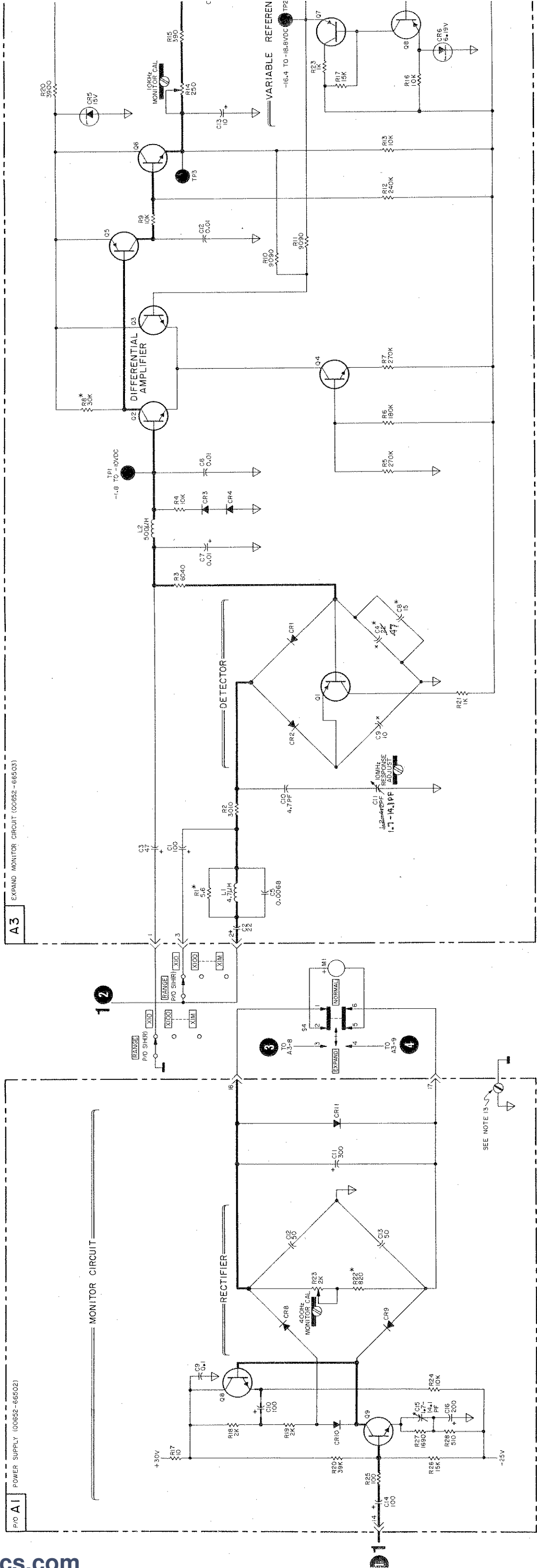

COPYRIGHT 1966 BY HEWLETT-PACKARD COMPANY

CHANGE PER HP SUPPLEMENT A, DATED 27 NOV 79 (27 DEC 82-0MK)

Figure 6:

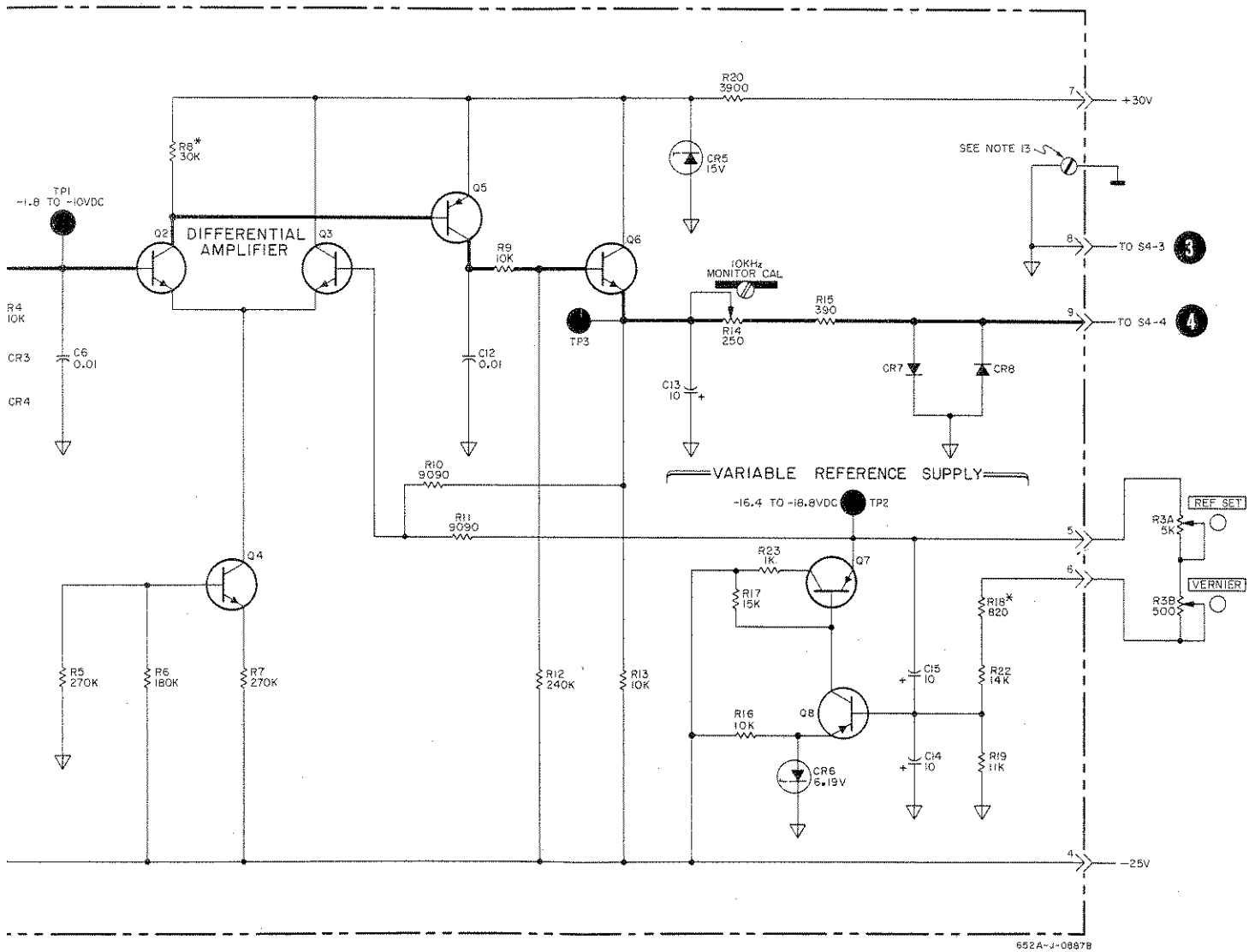

SUPPLEMENT A, DATED 27 NOV 79 (27 DEC 82 - DMK)

2

Figure 6-3. Normal and Expand Monitor Circuits.
 6-7/6-8

A1 ASSEMBLY

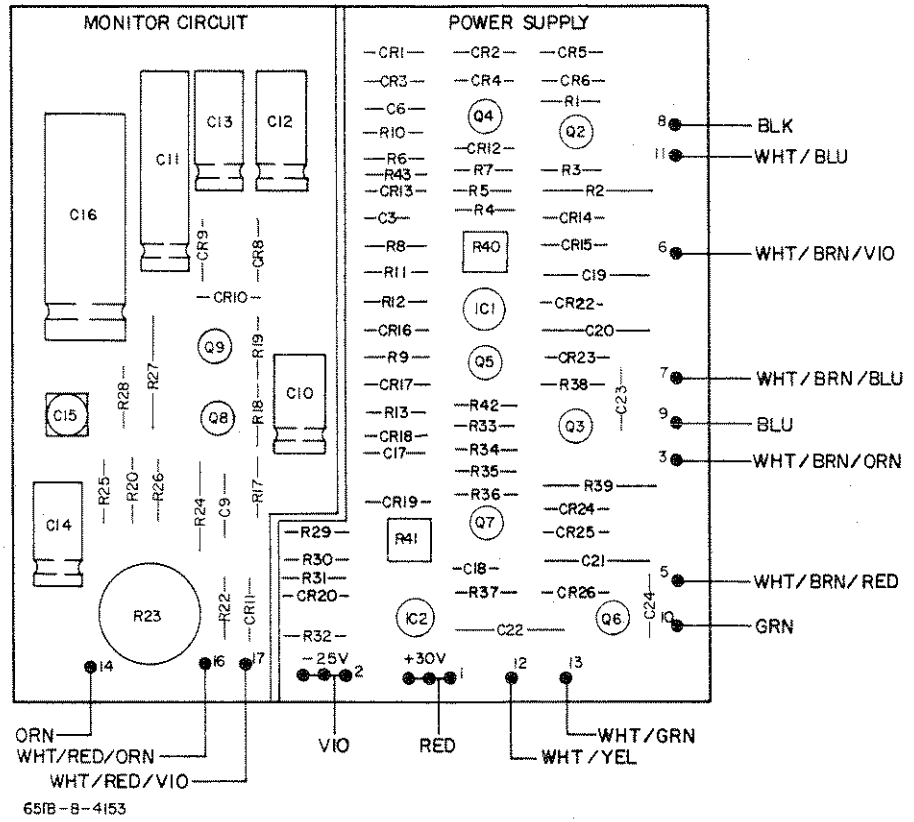

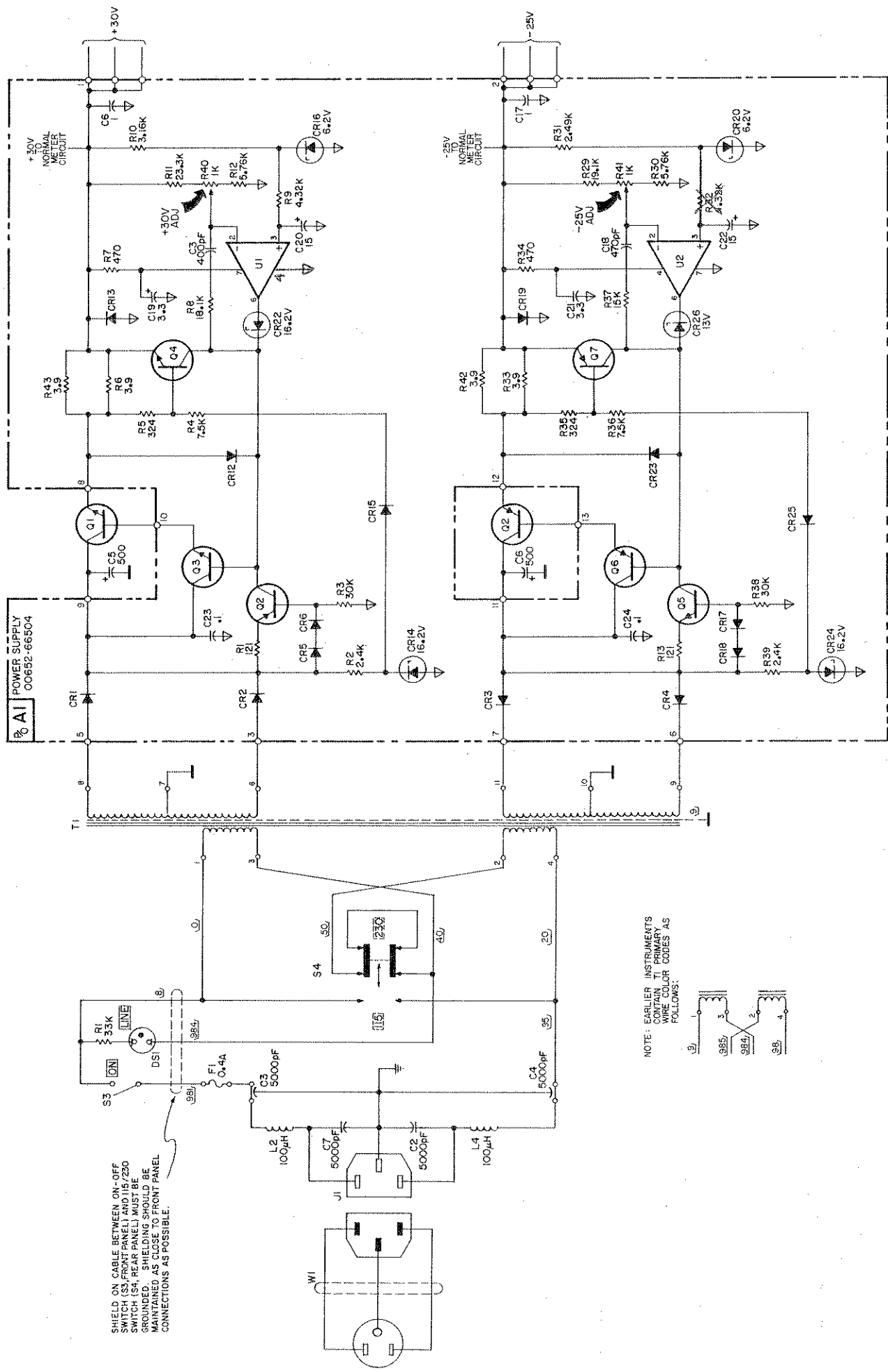

CHANGES PER HP SUPPLEMENT A, DATED 27 NOV 79 (27 DEL 82 - 00K)

3
Figure 6-4. Power Supply.
6-9/6-10

SECTION VII REPLACEABLE PARTS

7-1. INTRODUCTION.

7-2. This section contains information for ordering replacement parts. Figures 7-1 and 7-2 illustrate the important mechanical parts of the 652A. Table 7-1 lists parts in alphameric order of their reference designators and indicates the description, -hp- part number of each part, together with any applicable notes, and provides the following:

- a. Total quantity used in the instrument (TQ column). The total quantity of a part is given the first time the part number appears.
- b. Description of the part. (See list of abbreviations below.)
- c. Typical manufacturer of the part in a five-digit code. (See Appendix A for list of manufacturers.)
- d. Manufacturer's part number.

7-3. Miscellaneous parts are listed at the end of Table 7-1.

7-4. ORDERING INFORMATION.

7-5. To obtain replacement parts, address order or inquiry to your local Hewlett-Packard Field Office. (See Appendix B for list of office locations.) Identify parts by their Hewlett-Packard part numbers. Include instrument model and serial numbers.

7-6. NON-LISTED PARTS.

7-7. To obtain a part that is not listed, include:

- a. Instrument model number.
- b. Instrument serial number.
- c. Description of the part.
- d. Function and location of the part.

ABBREVIATIONS

<p>Ag silver Al aluminum A ampere(s) Au gold</p> <p>C capacitor cer ceramic coef coefficient com common comp composition conn connection</p> <p>dep deposited DPDT double-pole double-throw DPST double-pole single-throw</p> <p>elect electrolytic encap encapsulated</p> <p>F farad(s) FET field effect transistor fix fixed</p> <p>GaAs gallium arsenide GHz gigahertz = 10⁹ hertz gd guard(rod) Ge germanium grd ground(out)</p> <p>H henry(ies) Hg mercury Hz hertz (cycle(s) per second)</p>	<p>ID inside diameter imp impregnated incd incandescent ins insulation(s)</p> <p>kΩ kilohm(s) = 10³ ohms kHz kilohertz = 10³ hertz</p> <p>L inductor lin linear taper log logarithmic taper</p> <p>mA milliampere(s) = 10⁻³ amperes MHz megahertz = 10⁶ hertz MΩ megohm(s) = 10⁶ ohms met film metal film mfg manufacturer ms millisecond mtg mounting mV millivolt(s) = 10⁻³ volts μF microfarad(s) μs microsecond(s) μV microvolt(s) = 10⁻⁶ volts my Mylar</p> <p>nA nanoampere(s) = 10⁻⁹ amperes NC normally closed Ne neon NO normally open NPO negative positive zero (zero temperature coefficient)</p>	<p>ns nanosecond(s) = 10⁻⁹ seconds nr not separately replaceable</p> <p>Ω ohm(s) obd order by description OD outside diameter</p> <p>p peak pA picoampere(s) pc printed circuit pF picofarad(s) 10⁻¹² farads piv peak inverse voltage p/o part of pos position(s) poly polystyrene pot potentiometer P-P peak-to-peak ppm parts per million prec precision (temperature coefficient, long term stability, and/or tolerance)</p> <p>R resistor Rh rhodium rms root-mean-square rot rotary</p> <p>Se selenium sect section(s) Si silicon sl slide</p> <p>SPDT single-pole double-throw SPST single-pole single-throw</p> <p>Ta tantalum TC temperature coefficient TiO₂ titanium dioxide tog toggle tol tolerance trim trimmer TSTR transistor</p> <p>V volt(s) vacw alternating current working voltage var variable vdcw direct current working voltage</p> <p>W watt(s) w/ with w/v working inverse voltage w/o without ww wirewound</p> <p>* optimum value selected at factory, average value shown (part may be omitted) ** no standard type number assigned (selected or special type)</p>
---	---	---

Ⓜ Dupont de Nemours

DECIMAL MULTIPLIERS

Prefix	Symbols	Multiplier	Prefix	Symbols	Multiplier
tera	T	10 ¹²	centi	c	10 ⁻²
giga	G	10 ⁹	milli	m	10 ⁻³
mega	M or Meg	10 ⁶	micro	μ	10 ⁻⁶
kilo	K or k	10 ³	nano	n	10 ⁻⁹
hecto	h	10 ²	pico	p	10 ⁻¹²
deka	da	10	femto	f	10 ⁻¹⁵
deci	d	10 ⁻¹	atto	a	10 ⁻¹⁸

DESIGNATORS

<p>A assembly B motor BT battery C capacitor CR diode DL delay line DS lamp E misc electronic part F fuse</p>	<p>FL filter HR heater IC integrated circuit J jack K relay L inductor M meter MP mechanical part P plug</p>	<p>Q transistor QCR transistor-diode R resistor RT thermistor S switch T transformer TB terminal board TC thermocouple TP test point</p> <p>TS terminal strip V vacuum tube, neon bulb, photocell, etc. W cable X socket XDS lampholder XF fuseholder Y crystal Z network</p>
---	--	---

Rev 1

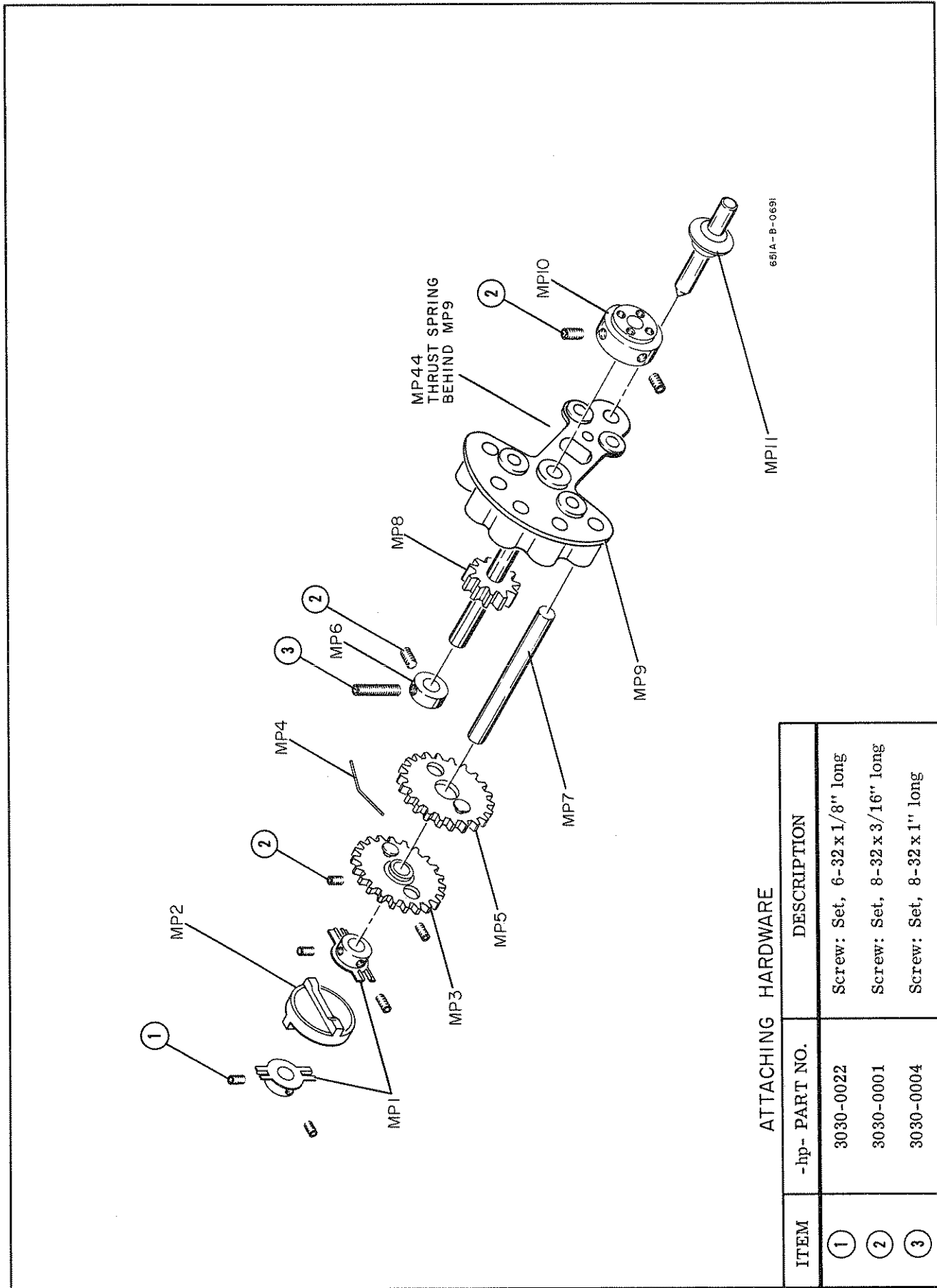

Figure 7-1. Frequency Tuning Assembly (Mechanical Parts)

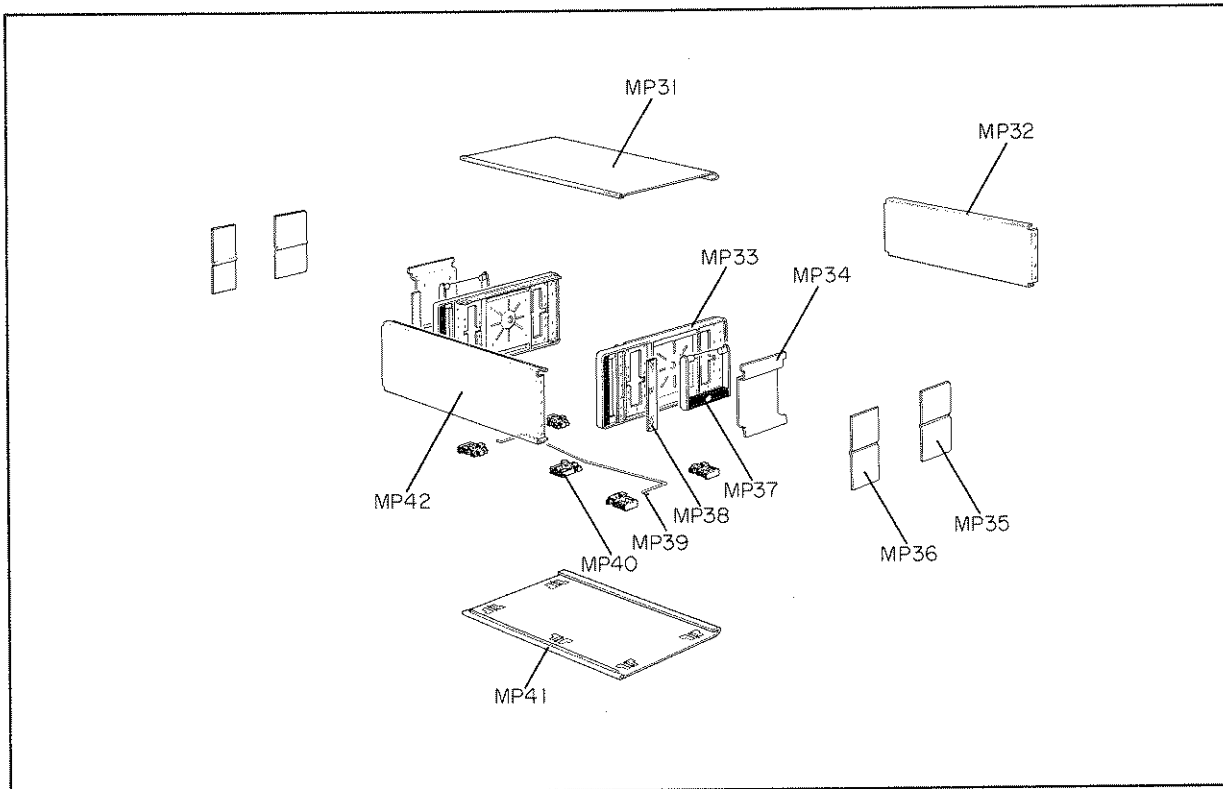
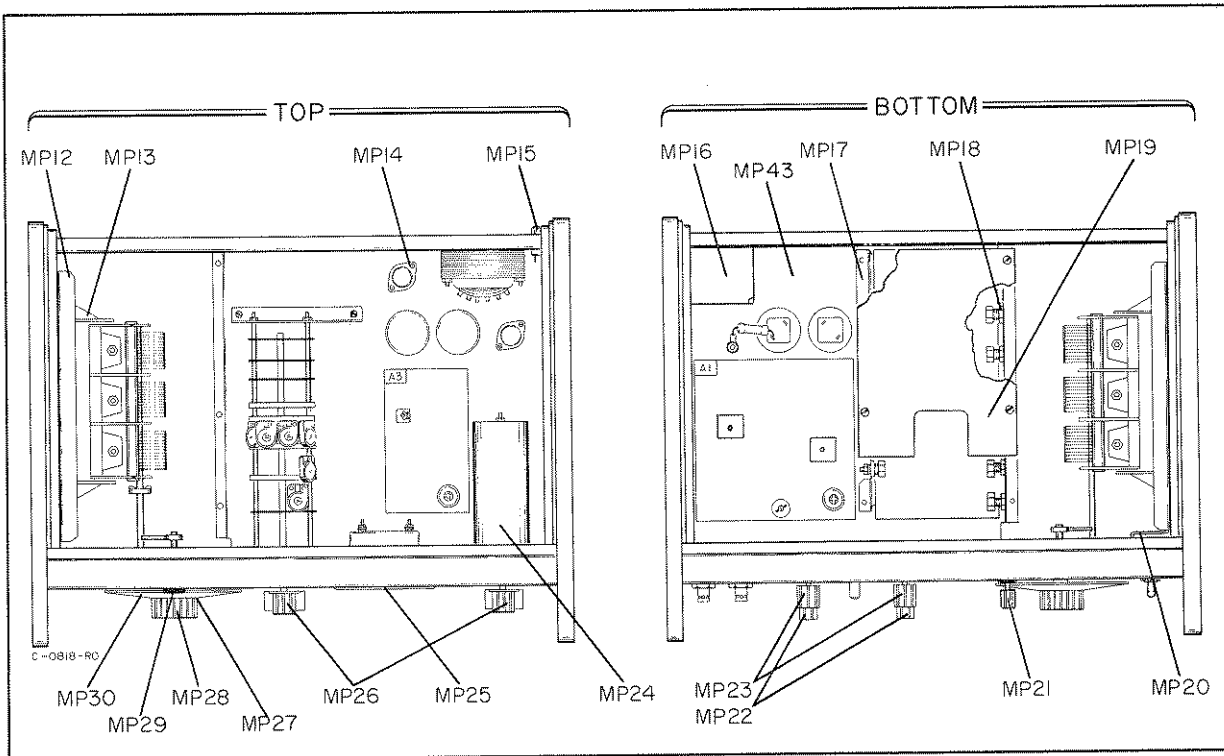

Figure 7-2. Chassis Components (Mechanical Parts)

Table 7-1. Replaceable Parts (Cont'd)

REFERENCE DESIGNATOR	-hp- PART NO.	TQ	DESCRIPTION	MFR.	MFR. PART NO.
A1	00652-66504		PC board: power supply	28480	00652-66504
A1C1			Not assigned		
A1C3	0140-0177		C: fxd 400 pF \pm 1% 300 vdcw	72136	DM15F401F0300WV1CR
A1C4			Not assigned		
A1C6	0180-0230		C: fxd 1 μ F \pm 20% 50 vdcw	56289	150D105X0050A2
A1C7, A1C8			Not assigned		
A1C9	0150-0084		C: fxd cer 0.1 μ F +80% -20% 50 vdcw	56289	33C41 obd
A1C10	0180-0061		C: fxd A1 elect 100 μ F +75% -10% 15 vdcw	56289	30DJ07G015DC2-DSM
A1C11	0180-0062		C: fxd A1 elect 300 μ F +75% -10% 6 vdcw	56289	30D307G006DF2-DSM
A1C12, A1C13	0180-0058		C: fxd A1 elect 50 μ F +75% -10% 25 vdcw	56289	30D506G025CCw-DSM
A1C14	0180-0061		C: fxd A1 elect 100 μ F +75% -10% 15 vdcw	56289	30D107G015DC2-DSM
A1C15	0121-0127		C: var air 1.7 to 14.1 pF	74970	189-505-5
A1C16	0180-0284		C: fxd A1 elect 200 μ F +75% -10% 30 vdcw	56289	D38559
A1C17	0180-0230		C: fxd 1 μ F \pm 20% 50 vdcw	56289	150D105X0050A2
A1C18	0140-0149		C: fxd 470 pF \pm 5% 300 vdcw	72136	DM15F471J0300WV1CR
A1C19	0180-0161		C: fxd 3.3 μ F \pm 20% 35 vdcw	56289	150D335X003582
A1C20	0180-1746		C: fxd 15 μ F \pm 10% 20 vdcw	56289	150D156X902082
A1C21	0180-0161		C: fxd 3.3 μ F \pm 20% 35 vdcw	56289	150D335X003582
A1C22	0180-1746		C: fxd 15 μ F \pm 10% 20 vdcw	56289	150D156X902082
A1C23, A1C24	0150-0084		C: fxd .1 μ F +80%, -20% 100 vdcw	28480	28480
A1CR1 thru A1CR4	1901-0158		Diode: Si	04713	SR1358-3 obd
A1CR5, CR6	1901-0040		Diode: Si 50 mA 30 V	28480	1901-0040
A1CR7			Not assigned		
A1CR8, CR9	1901-0347		Diode: Si 8 V 20 mA at +1 V 1.5 pF	28480	1901-0347
A1CR10	1910-0016		Diode: Ge 60 wiv	03877	S3185G obd
A1CR11	1901-0025		Diode: Si 100 mA at +1 V 100 piv 12 pF	03877	SG817 odb
A1CR12, CR13	1901-0040		Diode: Si 50 mA 30 V	28480	1901-0040
A1CR14	1902-0184		Diode: bkdn 16.2 V	28480	1902-0184
A1CR15	1901-0040		Diode: Si 50 mA 30 V	28480	1901-0040
A1CR16	1902-0777		Diode: TC REF	04713	1N825
A1CR17 thru CR19	1901-0040		Diode: Si 50 mA 30 V	28480	1901-0040
A1CR20	1902-0777		Diode: TC REF	04713	1N825
A1CR21			Not assigned		
A1CR22	1902-0184		Diode: Bkdn 16.2 V	28480	1902-0184
A1CR23	1901-0040		Diode: Si 50 mA 30 V	28480	1901-0050
A1CR24	1902-0184		Diode: Bkdn 16.2 V	28480	1902-0184
A1CR25	1901-0040		Diode: Si 50 mA 30 V	28480	1901-0040
A1CR26	1902-3190		Diode: Bkdn 13 V	04713	SZ10939-215
A1Q1			Not assigned		
A1Q2	1853-0037	3	Tstr: Si NPN	28480	1853-0037
A1Q3	1854-0474	3	Tstr: Si PNP	28480	1854-0474
A1Q4	1854-0474		Tstr: Si NPN	28480	1854-0474
A1Q5	1854-0474		Tstr: Si NPN	28480	1854-0474
A1Q6	1853-0037		Tstr: Si PNP	28480	1853-0037
A1Q7	1853-0037		Tstr: Si PNP	28480	1853-0037
A1Q8	1854-0071	2	Tstr: Si NPN (selected from 2N3704)	28480	1854-0071
A1Q9	1854-0042	2	Tstr: Si NPN SM1570	04713	SM1570
A1R1	0757-0403	2	R: fxd comp 121 Ω \pm 1% 1/8W	24546	C4-1/8-To-121-R-F
A1R2	0761-0024	2	R: fxd comp 2.4K \pm 5% 1 W	24546	FP32-1-Too-2401-J
A1R3	0683-3035	2	R: fxd comp 30K \pm 5% 1/4W	02212	CB3035
A1R4	0757-0440	2	R: fxd comp 7.5K \pm 1% 1/8W	24546	C4-1/8-To-7501-F
A1R5	0698-4450	2	R: fxd comp 324 Ω \pm 1% 1/8W	24546	C4-1/8-To-324R-F
A1R6	0683-0395	4	R: fxd comp 3.9 Ω \pm 5% 1/4W	01121	CB0395
A1R7	0683-4715	2	R: fxd comp 470 Ω \pm 5% 1/4W	01121	CB4715
A1R8	0683-1835	1	R: fxd comp 18K \pm 5% 1/4W	01121	CB1835
A1R9	0757-0436	2	R: fxd comp 4.32K \pm 1% 1/8W	24546	C4-1/8-To-4321-F
A1R10	0757-0279	1	R: fxd comp 3.16K \pm 1% 1/8W	24546	C4-1/8-To-3161-F

Table 7-1. Replaceable Parts (Cont'd)

REFERENCE DESIGNATOR	-hp- PART NO.	TQ	DESCRIPTION	MFR.	MFR. PART NO.
A1R11	0698-4485	2	R: fxd comp 23.2 k Ω \pm 1% 1/8W	24546	C4-1/8-To-2322-F
A1R12	0698-4445	2	R: fxd 5.76K \pm 1% 1/8W	16299	C4-1/8-To-5761-F
A1R13	0757-0403		R: fxd comp 121 Ω \pm 1% 1/8W	24546	C4-1/8-To-121R-F
A1R14	0757-1013	1	R: fxd met flm 6000 Ω \pm 1% 1/2W	75042	CEC T-O obd
A1R15	0689-0915		R: fxd comp carbon 9.1 Ω \pm 5% 1 W	01121	GB91G5
A1R16			Not assigned		
A1R17	0683-1005	1	R: fxd comp 10 Ω \pm 5% 1/4W	01121	CB1005
A1R18, R19	0683-2025	3	R: fxd comp 2000 Ω \pm 5% 1/4W	01121	CB2025
A1R20	0683-3935	2	R: fxd comp 39 k Ω \pm 5% 1/4W	01121	CB3935
A1R22*	0683-1025	4	R: fxd comp 1000 Ω \pm 5% 1/4W	01121	CB1025
A1R23	2100-0282	1	R: var ww 2000 Ω \pm 20% 1-1/2W	11236	110 obd
A1R24	0687-1031	1	R: fxd comp 10 k Ω \pm 10% 1/2W	01121	EB1035 obd
A1R25	0683-1015	2	R: fxd comp 100 Ω \pm 5% 1/4W	01121	CB1015
A1R26	0683-1535	1	R: fxd comp 15 k Ω \pm 5% 1/4W	01121	CB1535
A1R27	0698-0026	1	R: fxd met flm 1690 Ω \pm 1% 1/2W	19701	MF7C T-O obd
A1R28	0683-5115	1	R: fxd comp 510 Ω \pm 5% 1/4W	01121	CB5115
A1R29	0698-4483	1	R: fxd comp 18.7K \pm 1% 1/8W	24546	C4-1/8-To-1872-F
A1R30	0698-4445		R: fxd 5.76K \pm 1% 1/8W	16299	C4-1/8-To-5761-F
A1R31	0698-4435	1	R: fxd comp 2.49K \pm 1% 1/8W	16299	C4-1/8-To-2491-F
A1R32	0757-0436		R: fxd comp 4.32K \pm 1% 1/8W	24546	C4-1/8-To-4321-F
A1R33	0683-0395		R: fxd comp 3.9 Ω \pm 5% 1/4W	01121	CB0395
A1R34	0683-4715		R: fxd comp 470 Ω \pm 5% 1/4W	01121	CB4715
A1R35	0698-4450		R: fxd comp 324 Ω \pm 1% 1/8W	24546	C4-1/8-To-324R-F
A1R36	0757-0440		R: fxd comp 7.5K \pm 1% 1/8W	24546	C4-1/8-To-7501-F
A1R37	0683-1535		R: fxd comp 15 k Ω \pm 5% 1/4W	01121	CB1535
A1R38	0683-3035		R: fxd comp 30K \pm 5% 1/4W	01121	CB3035
A1R39	0761-0024		R: fxd comp 2.4K \pm 5% 1 W	24546	FP32-1-To-2401-J
A1R40, R41	2100-3211	2	R: var 1K \pm 10%	28480	2100-3211
A1R42, R43	0683-0395		R: fxd comp 3.9 Ω \pm 5% 1/4W	01121	CB0395
A1U1, U2	1826-0043	2	IC: OP AMP	27014	LM307H
	1200-0437	2	Socket: IC	17117	7009-265-5

CHANGE PER HP SUPPLEMENT A DATED 27 NOV 79 (27 DEC 82-DMK) 7-5

Table 7-1. Replaceable Parts (Cont'd)

REFERENCE DESIGNATOR	-hp- PART NO.	TQ	DESCRIPTION	MFR.	MFR. PART NO.
A2	00652-66501	1	Pc board: oscillator amplifier	28480	00652-66501
A2C1	0180-0061		C: fxd Al elect 100 μ F +75% -10% 15 vdcw	56289	30D107G015DC2-DSM
A2C2	0180-0237		C: fxd Al elect 500 μ F +75% -10% 25 vdcw	56289	39D507G025HE4DSB
A2C3, A2C4	0150-0084		C: fxd cer 0.1 μ F +80% -20% 50 vdcw	56289	33C41 obd
A2C5	0121-0127		C: var air 1.7 to 14.1 pF	74970	189-505-5
A2C6	0180-0305	1	C: fxd Al elect 1000 μ F +100% -10% 2.5 vdcw	56289	34D108H2R5FJ4
A2C7	0180-0112	1	C: fxd Al elect 2000 μ F 1 vdcw	56289	D33239
A2C8	0180-0062		C: fxd Al elect 300 μ F +75% -10% 6 vdcw	56289	30D307G006DF2-DSM
A2C9	0180-0076	1	C: fxd elect 20 μ F 25 vdcw	56289	40D206G025DC6-DST
A2C10	0150-0084		C: fxd cer 0.1 μ F +80% -20% 50 vdcw	56289	33C41 obd
A2C11	0180-0039	2	C: fxd Al elect 100 μ F +75% -10% 12 vdcw	56289	30D107G012CC2-DSM
A2C12	0180-2151	1	C: fxd Al elect 500 μ F +75% -10% 3 vdcw	56289	30D Non Polar
A2C13	0180-0039		C: fxd Al elect 100 μ F +75% -10% 12 vdcw	56289	30D107G012CC2-DSM
A2C14	0121-0127		C: var air 1.7 to 14.1 pF	74970	189-505-5
A2C15	0180-0062		C: fxd Al elect 300 μ F +75% -10% 6 vdcw	56289	30D307G006DF2-DSM
A2C16, A2C17	0180-0101	4	C: fxd Ta 1.8 μ F \pm 10% 35 vdcw	56289	150D185X9035B2
A2C18	0180-0306	1	C: fxd Al elect 300 μ F +100% -10% 15 vdcw	56289	34D307H015FJ4
A2C19	0180-0307	1	C: fxd Al elect 500 μ F +100% -10% 15 vdcw	56289	34D507H015FJ4
A2C20	0180-0101		C: fxd Ta 1.8 μ F \pm 10% 35 vdcw	56289	150D185X9035B2
A2C21*	0140-0201	1	C: fxd mica 12 pF \pm 5%	78488	RDM15C120J5C
A2C22	0180-1756	1	C: fxd Al elect 1200 μ F +100% -10%	56289	Type 34D Special obd
A2C23	0180-0101		C: fxd Ta 1.8 μ F \pm 10% 35 vdcw	56289	150D185X9035B2
A2C24*	0150-0022	1	C: fxd TiO ₂ 3.3 pF \pm 10%	78488	Type GA obd
A2C25*	0150-0043	1	C: fxd TiO ₂ 6.8 pF \pm 5% 500 vdcw	78488	Type GA obd
A2CR1	1902-0046	1	Diode: breakdown 7.15 V \pm 10% 400 mW	04713	10939-139 obd
A2CR2 thru 3	1901-0025				
A2CR4	1901-0025		Diode: Si 100 mA at +1 V 100 piv 12 pF	03877	SG-817
A2CR5 thru 6	1910-0016	4	Diode: Ge 60 wiv 1 ms	03877	S3185G obd
A2CR7, 8	1901-0014				
A2CR8, A2CR9	1901-0040	2	Diode: Si	03877	SG-5050
	1910-0016		Diode: Ge 60 wiv 1 ms	03877	S3185G obd
A2L1* thru A2L6*	9170-0016	7	Bead: shielding	02114	56-590-65/3B
A2Q1	1855-0082	1	TSTR: P FET channel Type A	04713	SS3723 obd
A2Q2	1854-0215	2	TSTR: Si NPN 2N3904	04713	SPS 3611
A2Q3	1853-0036	3	TSTR: Si PNP 2N3906	04713	SPS 3612
A2Q4, A2Q5	1854-0254	4	TSTR: Si NPN*	04713	
A2Q6	1853-0012	2	TSTR: Si PNP 2N2904A	04713	2N2904A
A2Q7	1854-0215		TSTR: Si NPN 2N3904	24446	2N3904
A2Q8	1854-0337		TSTR: Si NPN**	04713	SM1570-2

CHANGES PER HP SUPPLEMENT A, DATED 27 NOV 79 (27 DEC 82-DNA)

Table 7-1. Replaceable Parts (Cont'd)

REFERENCE DESIGNATOR	-hp- PART NO.	TQ	DESCRIPTION	MFR.	MFR. PART NO.
A2Q9	1853-0007	1	TSTR: Si PNP 2N3251	04713	2N3251
A2Q10, A2Q11	1854-0254		TSTR: Si NPN *	04713	obd
A2Q12	1853-0012		TSTR: Si PNP 2N2904A	04713	2N2904A
	1205-0037	2	Heat sink	98978	obd
A2R1	0687-1021	1	R: fxd comp 1000 Ω $\pm 10\%$ 1/2 W	01121	EB1021
A2R2	0683-6225	1	R: fxd comp 6200 Ω $\pm 5\%$ 1/4 W	01121	CB6225
A2R3	0683-4335		R: fxd comp 43 K Ω $\pm 5\%$ 1/4 W	01121	CB4335
A2R4	0683-1025	2	R: fxd comp 1000 Ω $\pm 5\%$ 1/4 W	01121	CB1025
A2R5	0684-1221	1	R: fxd comp 1200 Ω $\pm 10\%$ 1/4 W	01121	CB1221
A2R6	0683-9105	1	R: fxd comp 91 Ω $\pm 5\%$ 1/4 W	01121	CB9105
A2R7*	0683-0275	6	R: fxd comp 2.7 Ω $\pm 5\%$ 1/4 W	01121	CB27G5
A2R8, A2R9	0686-1025	2	R: fxd comp 1000 Ω $\pm 5\%$ 1/2 W	01121	EB1025
A2R10	0693-8211	1	R: fxd comp carbon 820 Ω $\pm 10\%$ 2W	01121	HB8211
A2R11, A2R12	0686-1305	3	R: fxd comp 13 Ω $\pm 5\%$ 1/2 W	01121	EB1305
A2R13	0687-1001	2	R: fxd comp 10 Ω $\pm 10\%$ 1/2 W	01121	EB1001
A2R14	0757-0739	2	R: fxd met flm 2000 Ω $\pm 1\%$ 1/4 W	19701	MF6C T-O obd
A2R15	0757-0736	1	R: fxd met flm 1500 Ω $\pm 1\%$ 1/4 W	19701	MF6C T-O obd
		1			
A2R16, A2R17	2100-2604	2	R: var lin 50 Ω $\pm 10\%$ 1/2 W	01121	Type SV5001
A2R19	0683-2035	1	R: fxd comp 20 K Ω $\pm 5\%$ 1/4 W	01121	CB2035
A2R20	0683-0275		R: fxd comp 2.7 Ω $\pm 5\%$ 1/4 W	01121	CB27G5
A2R21	0684-1031	4	R: fxd comp 10 K Ω $\pm 10\%$ 1/4 W	01121	CB1031
A2R22	0757-0739		R: fxd met flm 2000 Ω $\pm 1\%$ 1/4 W	19701	MF6C T-O obd
A2R23	0683-4705	1	R: fxd comp 47 Ω $\pm 5\%$ 1/4 W	01121	CB4705
A2R24*	0683-2025		R: fxd comp 2.0 k Ω $\pm 5\%$ 1/4 W	01121	CB2025
A2R25	0698-4657	2	R: fxd met flm 7.15K Ω $\pm 1\%$ 1/4 W	19701	MF6C T-O obd
A2R26	0687-1001		R: fxd comp 10 Ω $\pm 10\%$ 1/2 W	01121	EB1001
A2R27	0683-0275		R: fxd comp 2.7 Ω $\pm 5\%$ 1/4 W	01121	CB27G5
A2R28	0757-0500		R: fxd comp 30.1 Ω $\pm 1\%$ 1/4 W	19701	MF6C T-O obd
A2R29*	0683-1215	1	R: fxd comp 120 Ω $\pm 5\%$ 1/4 W	01121	CB1215
A2R30	0683-3935		R: fxd comp 39 K Ω $\pm 5\%$ 1/4 W	01121	CB3935
A2R31	0683-8235	1	R: fxd comp 82 K Ω $\pm 5\%$ 1/4 W	01121	CB8235
A2R32			Not assigned		
A2R33	0684-1521	2	R: fxd comp 15000 Ω $\pm 10\%$ 1/4 W	01121	CB1521
A2R34	0686-2025	1	R: fxd comp 2000 Ω $\pm 5\%$ 1/2 W	01121	EB2025
A2R35	0689-4315	1	R: fxd comp carbon 430 Ω $\pm 5\%$ 1 W	01121	GB4315
A2R36	0693-6811	1	R: fxd comp carbon 680 Ω $\pm 10\%$ 2 W	01121	HB6811
A2R37,					
A2R38	0683-0275		R: fxd comp 2.7 Ω $\pm 5\%$ 1/4 W	01121	CB27G5
A2R39,					
A2R40	0757-1012	2	R: fxd met flm 100 Ω $\pm 0.25\%$ 1/2 W	75042	CEC T-O obd
A2R41	0683-3615	1	R: fxd comp 360 Ω $\pm 5\%$ 1/4 W	01121	CB3615
A2R42, A2R43	0757-0159		R: fxd prec met flm 1000 Ω $\pm 1\%$ 1/2 W	-hp-	
A2R44	0683-0275		R: fxd comp 2.7 Ω $\pm 5\%$ 1/4 W	01121	CB27G5
A2R45	0757-0500	1	R: fxd met flm 30.1 Ω $\pm 1\%$ 1/4 W	75042	CEB T-O obd
A2R46	0757-0277	1	R: fxd met flm 49.9 Ω $\pm 1\%$ 1/8 W	75042	CEA T-O obd d
A2R47*	0698-4448	1	R: fxd met flm 29.4 Ω $\pm 1\%$ 1/8 W 274 Ω	-hp-	
	5061-0748	6	SOCKET ASSY: TSTR	28480	5061-0748
A3	00652-66503	1	PC board: expand meter circuit	28480	00652-66503
A3C1	0180-0098	3	C: fxd Ta elect 100 μ F $\pm 20\%$ 20 vdcw	56289	150D107X0020S2DYS
A3C2	0180-1794	2	C: fxd Ta elect 22 μ F $\pm 10\%$ 35 vdcw	56289	109D226X9025C2
A3C3	0180-0387		C: fxd Ta elect 47 μ F $\pm 5\%$ 20 vdcw	56289	150D476X5020R2
A3C4*	0180-1794		C: fxd 22 μ F 35 V	56289	150D226X9035R2DYS
A3C5	0160-0159	1	C: fxd my 0.0068 μ F $\pm 10\%$ 200 vdcw	56289	192P68292-PTS
A3C6, A3C7	0150-0093	3	C: fxd cer 0.01 μ F ± 80 -20% 100 vdcw	91418	TA obd
A3C8*	0180-1746	1	C: fxd elect 15 μ F 10% 20 vdcw	28480	0180-1746
A3C9	0180-0374	1	C: fxd Ta elect 10 μ F $\pm 10\%$ 20 vdcw	56289	150D106X9020B2
A3C10	0150-0042	1	C: fxd TiO ₂ 4.7 pF $\pm 5\%$ 500 vdcw	78488	Type GA obd
A3C11	0121-0131	1	C: var air 1.2 to 4.2 pF 1.7-14.1 pF	74970	189-501-5
A3C12	0150-0093		C: fxd cer 0.01 μ F $\pm 80\%$ -20% 100 vdcw	91418	TA obd

CHANGES PER HP SUPPLEMENT A, DATED 27 NOV 79 (27 DEC 82 - Dmk)

Table 7-1. Replaceable Parts (Cont'd)

REFERENCE DESIGNATOR	-hp- PART NO.	TQ	DESCRIPTION	MFR.	MFR. PART NO.
A3C13, A3C14	0180-0032	2	C: fxd Al elect 10 μ F +75% -10% 12 vdcw	56289	30D106G012BA4
A3C15	0180-0059	1	C: fxd elect 10 μ F +100% -10% 25 vdcw	56289	30D106G025BB2-DSM
A3CR1, A3CR2	1901-0456	2	Diode: Si hot carrier	-hp-	
A3CR3, A3CR4	1901-0025		Diode: Si 100 mA at +1 V 100 piv 12 pF	03877	SG-817 obd
A3CR5	1902-3205	1	Diode: Si breakdown 15 V \pm 5%	04713	SZ 10939-233
A3CR6	1902-0049	1	Diode: breakdown 6.19 V \pm 5% 400 mW	07263	obd
A3CR7	1910-0016		Diode: Ge 60 wiv	03877	S3185G obd
A3CR8	1901-0025		Diode: Si 100 mA at +1 V 100 piv 12 pF	03877	SG-817 obd
A3L1	9140-0025	1	Coil: radio frequency 4.7 μ H \pm 10%	99848	213-11 obd
A3L2	9140-0118	1	Coil: molded choke 500 μ H \pm 5%	82142	10178-8 obd
A3Q1	1853-0010	2	TSTR: Si PNP**	-hp-	
A3Q2 thru A3Q4	1854-0033	4	TSTR: Si NPN 2N3391	24446	2N3391
A3Q5	1853-0010		TSTR: Si PNP**	-hp-	
A3Q6	1854-0033		TSTR: Si NPN 2N3391	24446	2N3391
A3Q7, A3Q8	1853-0036	2	TSTR: Si PNP 2N3906	04713	SPS-3612
A3R1*	0683-0565	1	R: fxd comp 5.6 Ω \pm 5% 1/4 W	01121	CB56G5
A3R2	0757-0339	1	R: fxd met flm 3010 Ω \pm 1% 1/4 W	19701	MF6C T-O obd
A3R3	0757-1023	1	R: fxd met flm 6040 Ω \pm 1% 1/4 W	19701	MF6C T-O obd
A3R4	0757-0340	1	R: fxd met flm 10 K Ω \pm 1% 1/4 W	19701	MF6C T-O obd
A3R5	0683-2745	3	R: fxd comp 270 K Ω \pm 5% 1/4 W	01121	CB2745
A3R6	0683-1845	1	R: fxd comp 180 K Ω \pm 5% 1/4 W	01121	CB1845
A3R7	0683-2745		R: fxd comp 270 K Ω \pm 5% 1/4 W	01121	CB2745
A3R8*	0683-3035	1	R: fxd comp 30 K Ω \pm 5% 1/4 W	01121	CB3035
A3R9	0684-1031		R: fxd comp 10 K Ω \pm 10% 1/4 W	01121	CB1031
A3R10, A3R11	0757-0753	2	R: fxd met flm 9090 Ω \pm 1% 1/4 W	19701	MF6C T-O obd
A3R12	0683-2445	1	R: fxd comp 240 K Ω \pm 5% 1/4 W	01121	CB2445
A3R13	0684-1031		R: fxd comp 10 K Ω \pm 10% 1/4 W	01121	CB1031
A3R14	2100-0439	1	R: var ww 250 Ω \pm 20% 1-1/2 W	11236	110 obd
A3R15	0683-3915		R: fxd comp 390 Ω \pm 5% 1/4 W	01121	CB3915
A3R16	0684-1031		R: fxd comp 10 K Ω \pm 10% 1/4 W	01121	CB1031
A3R17	0684-1531	1	R: fxd comp 15 K Ω \pm 10% 1/4 W	01121	CB1531
A3R18*	0683-8215	1	R: fxd comp 820 Ω \pm 5% 1/4 W	01121	CB2205
A3R19	0757-0754	1	R: fxd met flm 11 K Ω \pm 1% 1/4 W	19701	MF6C T-O obd
A3R20	0684-3921	1	R: fxd comp 3900 Ω \pm 10% 1/4 W	01121	CB3921
A3R21	0684-1021	2	R: fxd comp 1000 Ω \pm 10% 1/4 W	01121	CB1021
A3R22	0698-4715		R: fxd met flm 14.0 K Ω \pm 1% 1/4 W	91637	MFF-1/8-32 T-1
A3R23	0684-1021		R: fxd comp 1000 Ω \pm 10% 1/4 W	01121	CB1021
C1A thru C1C	0121-0018	1	C: var air 3-sect 14.75 pF to 617.75 pF	-hp-	
C2	0160-3333	3	C: fxd cer 5000 pF \pm 20% 250 vdcw	08988	THD-8-502M-1.4 KV
C3, C4	0160-3333		C: fxd cer 5000 pF \pm 20% 250 vdcw	08988	THD-8-502M-1.4 KV
C5, C6	0180-0047	2	C: fxd Al elect 500 μ F 75 vdcw	56289	D32443 obd
C7	0160-3333		C: fxd cer 5000 pF \pm 20% 250 vdcw	08988	THD-8-502M-1.4 KV
DS1	2140-0015	1	Lamp: neon T-2 bulb NE2H	24446	obd
	5040-0234	1	Pilot light: jewel	-hp-	
	5040-0235	1	Pilot light: base	-hp-	
F1	2110-0340	1	Fuse: 0.4 A slow-blow 250 V	71400	MDL 4/10
J1	1251-2357	1	Receptacle: power	82389	EAC-301
L1 thru L3			Not assigned		
L4	9140-0029	1	Coil: radio frequency 100 μ F	99848	3100-15-101
L5*	9170-0016		Bead: shielding	02114	56-590-65A 1/3 B
M1	1120-0922	1	Meter: 50 Ω DBM scale	-hp-	
MP1	1500-0253	2	Yoke: flexible coupler	99934	A-201-142
MP2	1500-0004	1	Insulator: flexible coupling	99934	A-201-1
MP3	5060-0021	1	Gear Assembly	-hp-	

Table 7-1. Replaceable Parts (Cont'd)

REFERENCE DESIGNATOR	-hp- PART NO.	TQ	DESCRIPTION	MFR.	MFR. PART NO.
MP4	1460-0256	1	Spring: compression	-hp-	
MP5	5060-0020	1	Gear Assembly	-hp-	
MP6	5020-0233	1	Collar	-hp-	
MP7	5020-0348	1	Shaft	-hp-	
MP8	5020-0641	1	Shaft: spur gear	-hp-	
MP9	5020-0639	1	Casting: Capacitor drive assembly	-hp-	
MP10	5020-0630	1	Hub: dial	-hp-	
MP11	5040-0607	1	Disc assembly: vernier drive	-hp-	
MP12	00651-00102	1	Plate: capacitor	-hp-	
MP13	5040-0631	2	Bracket: capacitor mount	-hp-	
MP14	0340-0580	2	Insulator: TSTR mounting	000LB	293011 obd
MP15	2110-0359	1	Fuseholder	91967	450
	2110-0564	1	Fuseholder		
MP16	00651-05503	1	Shield: filter	-hp-	
MP17	00652-05506	1	Shield: separates board	-hp-	
MP18	1205-0241 1205-0220	6	Semiconductor-thermal link	13103	12017
MP19	00652-04101	1	Plate: cover over A2 board	-hp-	
	2110-0565	1	Cap-Fuseholder		
MP20	00651-05501	1	Shield: power over switch	-hp-	
MP21	0370-0025	1	Knob: round black vernier	-hp-	
MP22	0370-0114	2	Knob: round red	-hp-	
MP23	0370-0116	2	Knob: round black	-hp-	
	2110-0569	1	Nut-Fuseholder		
MP24	00651-05504	1	Shield: outer cover	-hp-	
MP25	4040-0297	1	Bezel: meter window	-hp-	
MP26	0370-0112	2	Knob: bar skirted black	-hp-	
MP27	61B-40D-4	1	Plate: frequency dial	-hp-	
MP28	0370-0160	1	Knob: round black dial	-hp-	
	1400-0090	1	Washer		
MP29	5040-5158	1	Indicator: dial	-hp-	
MP30	00651-04001	1	Dial	-hp-	
MP31	5060-8587	1	Cover assembly: top 11" long	-hp-	
MP32	00651-00213	1	Panel: rear	-hp-	
MP33	5060-0731	2	Frame assembly: 5 x 11 full module	-hp-	
MP34	5060-8737	2	Retainer: handle 5" high	-hp-	
MP35	5000-8597	2	Cover: side rear 5 x 11 full module	-hp-	
MP36	5000-8599	2	Cover: side front 5 x 11 full module	-hp-	
MP37	5060-0222	2	Handle assembly: 5" high side	-hp-	
MP38	5000-0051	2	Cabinet trim	-hp-	
MP39	1490-0030	1	Stand: tilt stainless steel rod	91260	obd
MP40	5060-0767	5	Foot assembly: full module	-hp-	
MP41	5060-8711	1	Cover assembly: bottom 11" long	-hp-	
MP42	00652-00202	1	Panel: front	-hp-	
MP43	00651-00113	1	Deck: main	-hp-	
MP44	5000-0637	1	Spring: thrust	-hp-	
Q1	1854-0063	1	TSTR: SI NPN 2N3055	-hp-	
Q2	1853-0305	1	TSTR: SI PNP	-hp-	
R1	0684-3331-0683-2235	1	R: fxd comp 33kΩ ± 10% 1/4 W 22kΩ ± 5%	01121	CB3331
R2	2100-1996	1	R: var pot	71590	Model 12 obd
R3	2100-1997	1	R: var pot	71590	Model 12 obd
S1	00652-61901	1	Switch assembly: range	-hp-	
S1C1	0140-0040	1	C: fxd mica 75 pF ± 5%	04062	RCM 15E 750J
S1C2	0130-0006	3	C: var cer 5 to 20 pF	72982	503 000 B2PO28R
S1C3	0140-0032	1	C: fxd mica 47 pF ± 10%	04062	RCM15F 470K
S1C4	0130-0001	1	C: var cer 7 to 45 pF	72982	503-000-D2PO-33R
S1C5	0130-0006	1	C: var cer 5 to 20 pF	72982	503 000 B2PO28R
S1C6	0160-0987	1	C: fxd mica 12 pF ± 5%	04062	RDM15C120J5S
S1C7	0130-0006	1	C: var cer 5 to 20 pF	72982	503 000 B2PO28R

CHANGES PER HP SUPPLEMENT A, DATED 27 NOV 79 (27 DEC 82 - DMK)

Table 7-1. Replaceable Parts (Cont'd)

REFERENCE DESIGNATOR	-hp- PART NO.	TQ	DESCRIPTION	MFR.	MFR. PART NO.
S1C8	0140-0003 0150-0045	1	C: fxd mica 10 pF $\pm 10\%$ 8.2 pF	14655	obd
S1C9, S1C10	0130-0003	2	C: var cer 1.5 to 7 pF	72982	503-000 COPO-10R
S1C11	0150-0046	1	C: fxd TiO ₂ 0.68 pF $\pm 5\%$ 500 vdcw	78488	Type GA obd
S1C12	0150-0029	2	C: fxd TiO ₂ 1 pF $\pm 10\%$ 500 vdcw	78488	Type GA obd
S1C13*	0150-0029		C: fxd TiO ₂ 1 pF $\pm 10\%$ 500 vdcw	78488	Type GA obd
S1C14*	0150-0044 0140-0062	1	C: fxd TiO ₂ 5.6 pF $\pm 5\%$ 500 vdcw 10 pF	78488	Type GA obd
S1C15*	0150-0031	1	C: fxd TiO ₂ 2.0 pF $\pm 5\%$ 500 vdcw	78488	Type GA obd
S1R1*	0686-5145	1	R: fxd comp 510 k Ω $\pm 5\%$ 1/2 W	01121	EB5145
S1R2	0730-0145	1	R: fxd carbon flm 12 M Ω $\pm 1\%$ 1 W	91637	DC-1
S1R3*	0687-3931	1	R: fxd comp 39 k Ω $\pm 10\%$ 1/2 W	01121	EB3931
S1R4	0757-0983	1	R: fxd met flm 1.23 M Ω $\pm 1\%$ 1/2 W	75042	CEC T-O obd
S1R5*	0687-4721	1	R: fxd comp 4.7 k Ω $\pm 10\%$ 1/2 W	01121	EB4721
S1R6	0757-0981	1	R: fxd met flm 123 k Ω $\pm 1\%$ 1/2 W	75042	CEC T-O obd
S1R7*	0687-3911	1	R: fxd comp 390 Ω $\pm 10\%$ 1/2 W	01121	EB3911
S1R8	0757-0042	1	R: fxd met flm 12.3 k Ω $\pm 1\%$ 1/2 W	75042	CEC T-O obd
S1R9*	0687-6801	1	R: fxd comp 68 Ω $\pm 10\%$ 1/2 W	01121	EB6801
S1R10	0757-0821	1	R: fxd met flm 1.21 k Ω $\pm 1\%$ 1/2 W	75042	CEC T-O obd
S1R11*	0687-2701	2	R: fxd comp 27 Ω $\pm 10\%$ 1/2 W	01121	EB2701
S1R12	0757-0198	1	R: fxd met flm 100 Ω $\pm 1\%$ 1/2 W	19701	MF7C T-O obd
S1R13	0733-0006	1	R: fxd carbon flm 24.5 M Ω $\pm 1\%$ 2 W	91637	DC-2 obd
S1R14*	0686-1855	1	R: fxd comp 1.8 M Ω $\pm 5\%$ 1/2 W	01121	EB1855
S1R15	0757-1017	1	R: fxd met flm 2.45 M Ω $\pm 1\%$ 1/2 W	75042	CEC T-O obd
S1R16*	0686-1245	1	R: fxd comp 120 k Ω $\pm 5\%$ 1/2 W	01121	EB1245
S1R17	0757-0982	1	R: fxd met flm 245 k Ω $\pm 1\%$ 1/2 W	75042	CEC T-O obd
S1R18*	0687-1031	1	R: fxd comp 10 k Ω $\pm 10\%$ 1/2 W	01121	EB1031
S1R19	0757-1014	1	R: fxd met flm 24.5 k Ω $\pm 1\%$ 1/2 W	75042	CEC T-O obd
S1R20*	0687-1021	1	R: fxd comp 1000 Ω $\pm 10\%$ 1/2 W	01121	EB1021
S1R21	0757-0038	1	R: fxd met flm 2510 Ω $\pm 1\%$ 1/2 W	75042	CEC T-O obd
S1R22*	0687-5601	1	R: fxd comp 56 Ω $\pm 10\%$ 1/2 W	01121	EB5601
S1R23	0757-0980	1	R: fxd met flm 225 Ω $\pm 1\%$ 1/2 W	75042	CEC T-O obd
S1R24*	0687-2701	1	R: fxd comp 27 Ω $\pm 5\%$ 1/2 W	01121	EB2701
S2	00651-63402	1	Attenuator assembly	-hp-	
S2R1, S2R2	0698-8386	2	R: fxd met flm 790 Ω $\pm .1\%$ 1/2 W	75042	CEC T-O obd
S2R3	0698-8387	1	R: fxd met flm 247.5 Ω $\pm .1\%$ 1/2 W	75042	CEC T-O obd
S2R4	0698-8388	1	R: fxd met flm 71.15 Ω $\pm .1\%$ 1/2 W	75042	CEC T-O obd
S2R5 thru S2R8	0698-8389	4	R: fxd met flm 53.27 Ω $\pm .1\%$ 1/2 W	75042	CEC T-O obd
S2R9, S2R10	0698-7984	2	R: fxd met flm 61.11 Ω $\pm .1\%$ 1/2 W	75042	CEC T-O obd
S2R11, S2R12	0698-8390	2	R: fxd met flm 96.25 Ω $\pm .1\%$ 1/2 W	75042	CEC T-O obd
S2R13	0757-1016	1	R: fxd met flm 550 Ω $\pm .25\%$ 1/2 W	75042	CEC T-O obd
S3	3101-2147	1	Switch: toggle power SPST	88140	8928K61
S4	3101-0036	1	Switch: monitor	-hp-	
S5	3101-0805	1	Switch: slide	82389	11A-1242A
T1	9100-3239	1	Transformer: Power 115/230 V	hp-	
W1	8120-1348	1	Assembly Cable: Power Cord 7.5 feet	70903	KH-4147
	5061-0735	1	TUNER ASSY (Consists of C1A thru C1C and MP13)	28480	5061-0735
			<u>MISCELLANEOUS</u>		
	1200-0081	4	Bushing (for MP18)	26365	974 Special
	1205-0220		Semi-heat dissipator	-hp-	
	00651-61604	1	Cable: power	-hp-	
	00652-61601	1	Cable: panel controls	-hp-	
	00651-61602	1	Cable assembly: input	-hp-	
	00651-61601	2	Cable assembly: output	-hp-	
	2110-0340		Fuse: Type designator 2B250V .4A	-hp-	
	00652-90005	1	Manual: operating and service	-hp-	
	00652-84402	1	Rack mount kit	-hp-	

CHANGES PER HP SUPPLEMENT A, DATED 27 NOV 79 (27 DEC 82 - Bmk)

CODE LIST OF MANUFACTURERS

The following code numbers are from the Federal Supply Code for Manufacturers Cataloging Handbooks H4-1 (Name to Code) and H4-2 (Code to Name) and their latest supplements. The date of revision and the date of the supplements used appear at the bottom of each page. Alphabetical codes have been arbitrarily assigned to suppliers not appearing in the H4 Handbooks.

Code No.	Manufacturer	Address	Code No.	Manufacturer	Address	Code No.	Manufacturer	Address
00000	U. S. A Common	Any supplier of U. S.	05347	Ultronix, Inc.	San Mateo, Cal.	11236	CTS of Berne, Inc.	Berne, Ind.
00136	McCoy Electronics	Mount Holly Springs, Pa.	05397	Union Carbine Corp., Elect. Div.	New York, N. Y.	11237	Chicago Telephone of California, Inc.	So. Pasadena, Cal.
00213	Sage Electronics Corp.	Rochester, N. Y.	05574	Viking Ind. Inc.	Canoga Park, Cal.	11242	Bay State Electronics Corp.	Waltham, Mass.
00287	Cemco, Inc.	Danielson, Conn.	05593	Icore Electro-Plastics Inc.	Sunnyvale, Cal.	11312	Teledyne Inc., Microwave Div.	Palo Alto, Cal.
00334	Humidial	Colton, Calif.	05616	Cosmo Plastic (c/o Electrical Spec. Co.)	Cleveland, Ohio	11314	National Seal	Downey, Cal.
00348	Mictron, Co., Inc.	Valley Stream, N. Y.	05624	Barber Colman Co.	Rockford, Ill.	11453	Precision Connector Corp.	Jamaica, N. Y.
00373	Garlock Inc.	Cherry Hill, N. J.	05728	Tiffen Optical Co.	Roslyn Heights, Long Island, N. Y.	11534	Duncan Electronics Inc.	Costa Mesa, Cal.
00656	Aerovox Corp.	New Bedford, Mass.	05729	Metro-Tel Corp.	Westbury, N. Y.	11711	General Instrument Corp., Semiconductor Division Products Group	Newark, N. J.
00779	Amp. Inc.	Harrisburg, Pa.	05763	Stewart Engineering Co.	Santa Cruz, Cal.	11717	Imperial Electronic, Inc.	Buena Park, Cal.
00781	Aircraft Radio Corp.	Bonton, N. J.	05783	Wakefield Engineering Inc.	Wakefield, Mass.	11870	Melabs, Inc.	Palo Alto, Cal.
00809	Croven, Ltd.	Whitby, Ontario, Canada	05820	Bassick Co., Div. of Stewart Warner Corp.	Bridgeport, Conn.	12136	Philadelphia Handle Co.	Camden, N. J.
00815	Northern Engineering Laboratories, Inc.	Burlington, Wis.	06004	Raychem Corp.	Redwood City, Cal.	12361	Grove Mfg. Co., Inc.	Shady Grove, Pa.
00853	Sangamo Electric Co., Pickens Div.	Pickens, S. C.	06175	Bausch and Lomb Optical Co.	Rochester, N. Y.	12574	Gulton Ind. Inc., Data System Div.	Albuquerque, N. M.
00866	Goe Engineering Co.	City of Industry, Cal.	06402	E. T. A. Products Co. of America	Chicago, Ill.	12697	Clarostat Mfg. Co.	Dover, N. H.
00891	Carl E. Holmes Corp.	Los Angeles, Cal.	06540	Amatom Electronic Hardware Co., Inc.	New Rochelle, N. Y.	12728	Elmar Filter Corp.	W. Haven, Conn.
00929	Microlab Inc.	Livingston, N. J.	06555	Beede Electrical Instrument Co., Inc.	Penacook, N. H.	12859	Nippon Electric Co., Ltd.	Tokyo, Japan
01002	General Electric Co., Capacitor Dept.	Hudson Falls, N. Y.	06666	General Devices Co., Inc.	Indianapolis, Ind.	12881	Metex Electronics Corp.	Clark, N. J.
01009	Alden Products Co.	Brockton, Mass.	06751	Components Inc., Ariz. Div.	Phoenix, Arizona	12930	Delta Semiconductor Inc.	Newport Beach, Cal.
01121	Allen Bradley Co.	Milwaukee, Wis.	06812	Torrington Mfg. Co., West Div.	Van Nuys, Cal.	12954	Dickson Electronics Corp.	Scottsdale, Arizona
01255	Litton Industries, Inc.	Beverly Hills, Cal.	06980	Varian Assoc. Etmac Div.	San Carlos, Cal.	13019	Aircro Supply Co., Inc.	Witchita, Kansas
01281	TRW Semiconductors, Inc.	Lawndale, Cal.	07088	Kelvin Electric Co.	Van Nuys, Cal.	13061	Wilco Products	Detroit, Mich.
01295	Texas Instruments, Inc., Transistor Products Div.	Dallas, Texas	07126	Digitran Co.	Pasadena, Cal.	13103	Thermolloy	Dallas, Texas
01349	The Alliance Mfg. Co.	Alliance, Ohio	07137	Transistor Electronics Corp.	Minneapolis, Minn.	13327	Soliton Devices Inc.	Tappan, N. Y.
01538	Small Parts Inc.	Los Angeles, Cal.	07138	Westinghouse Electric Corp., Electronic Tube Div.	Elmira, N. Y.	13396	Telefunken (GmbH)	Hanover, Germany
01589	Pacific Relays, Inc.	Van Nuys, Cal.	07149	Filmohm Corp.	New York, N. Y.	13835	Midland-Wright Div. of Pacific Industries, Inc.	Kansas City, Kansas
01670	Gudebrod Bros. Silk Co.	New York, N. Y.	07233	Cinch-Graphix Co.	City of Industry, Cal.	14099	Sem-Tech	Newbury Park, Cal.
01930	Amerock Corp.	Rockford, Ill.	07256	Silicon Transistor Corp.	Carle Place, N. Y.	14193	Calif. Resistor Corp.	Santa Monica, Cal.
01960	Pulse Engineering Co.	Santa Clara, Cal.	07261	Avnet Corp.	Culver City, Cal.	14298	American Components, Inc.	Conshohocken, Pa.
02114	Ferroxcube Corp. of America	Saugerties, N. Y.	07263	Fairchild Camera & Inst. Corp., Semiconductor Div.	Mountain View, Cal.	14433	ITT Semiconductor, a Div. of Int. Telephone and Telegraph Corporation	West Palm Beach, Fla.
02116	Wheelock Signals, Inc.	Long Branch, N. J.	07322	Minnesota Rubber Co.	Minneapolis, Minn.	14493	Hewlett-Packard Company	Loveland, Colo.
02286	Cole Rubber and Plastics Inc.	Sunnyvale, Cal.	07387	Birtcher Corp, The	Monterey Park, Cal.	14655	Cornell Dublier Electric Corp.	Newark, N. J.
02660	Amphenol-Borg Electronics Corp.	Broadview, Ill.	07397	Sylvania Elect. Prod. Inc., Mt. View Operations	Mountain View, Cal.	14674	Corning Glass Works	Corning, N. Y.
02735	Radio Corp. of America, Semiconductor and Materials Division	Somerville, N. J.	07700	Technical Wire Products Inc.	Cranford, N. J.	14752	Electro Cube Inc.	San Gabriel, Cal.
02771	Vocaline Co. of America, Inc.	Old Saybrook, Conn.	07829	Bodine Elect. Co.	Chicago, Ill.	14960	Williams Mfg. Co.	San Jose, Cal.
02777	Hopkins Engineering Co.	San Fernando, Cal.	07910	Continental Device Corp.	Hawthorne, Cal.	15106	The Sphere Co., Inc.	Little Falls, N. J.
02875	Hudson Tool & Die	Newark, N. J.	07933	Raytheon Mfg. Co., Semiconductor Div.	Mountain View, Cal.	15203	Webster Electronics Co.	New York, N. Y.
03296	Nylon Molding Corp.	Springfield, N. J.	07980	Hewlett-Packard Co., New Jersey Division	Rockaway, N. J.	15287	Seionics Corp.	Northridge, Cal.
03508	G. E. Semiconductor Prod. Dept.	Syracuse, N. Y.	08145	U. S. Engineering Co.	Los Angeles, Cal.	15291	Adjustable Bushing Co.	N. Hollywood, Cal.
03705	Apex Machine & Tool Co.	Dayton, Ohio	08289	Blinn, Delbert Co.	Pomona, Cal.	15558	Micron Electronics	Garden City, Long Island, N. Y.
03797	Eldema Corp.	Compton, Calif.	08358	Burgess Battery Co.	Niagara Falls, Ontario, Canada	15566	Amprobe Inst. Corp.	Lybrook, N. Y.
03818	Parker Seal Co.	Los Angeles, Cal.	08524	Deutsch Fastener Corp.	Los Angeles, Cal.	15631	Cabletronics	Costa Mesa, Cal.
03877	Transitron Electric Corp.	Wakefield, Mass.	08664	Bristol Co., The	Waterbury, Conn.	15772	Twentieth Century Coil Spring Co.	Santa Clara, Cal.
03888	Pyrofilm Resistor Co., Inc.	Cedar Knolls, N. J.	08717	Sloan Company	Sun Valley, Cal.	15801	Fenwal Elect. Inc.	Frammingham, Mass.
03954	Singer Co., Diehl Div., FINDERNE Plant	Sumerville, N. J.	08718	ITT Cannon Electric Inc., Phoenix Div.	Phoenix, Arizona	15818	Amelco Inc.	Mountain View, Cal.
04009	Arrow, Hart and Hegeman Elect. Co.	Hartford, Conn.	08727	National Radio Lab. Inc.	Paramus, N. J.	16037	Spruce Pine Mica Co.	Spruce Pine, N. C.
04013	Taruus Corp.	Lambertville, N. J.	08792	CBS Electronics Semiconductor Operations, Div. of CBS Inc.	Lowell, Mass.	16179	Omni-Spectra Inc.	Detroit, Ill.
04062	Arco Electronic Inc.	Great Neck, N. Y.	08806	General Electric Co., Miniature Lamp Dept.	Cleveland, Ohio	16352	Computer Diode Corp.	Lodi, N. J.
04217	Essex Wire	Los Angeles, Cal.	08984	Mel-Rain	Indianapolis, Ind.	16554	Electroid Co.	Union, N. J.
04222	Hi-Q Division of Aerovox	Myrtle Beach, S. C.	09026	Babcock Relays Div.	Costa Mesa, Cal.	16585	Boots Aircraft Nut Corp.	Pasadena, Cal.
04354	Precision Paper Tube Co.	Wheeling, Ill.	09097	Electronic Enclosures Inc.	Los Angeles, Calif.	16688	Ideal Prec. Meter Co., Inc., De Jur Meter Div.	Brooklyn, N. Y.
04404	Palo Alto Division of Hewlett-Packard Co.	Palo Alto, Cal.	09134	Texas Capacitor Co.	Houston, Texas	16758	Delco Radio Div. of G. M. Corp.	Kokomo, Ind.
04651	Sylvania Electric Products, Microwave Device Div.	Mountain View, Cal.	09145	Tech. Ind. Inc. Atohm Elect.	Burbank, Cal.	17109	Thermometrics Inc.	Canoga Park, Cal.
04673	Dakota Engr. Inc.	Culver City, Cal.	09250	Electro Assemblies, Inc.	Chicago, Ill.	17474	Tranex Company	Mountain View, Cal.
04713	Motorola Inc. Semiconductor Prod. Div.	Phoenix, Arizona	09353	C & K Components Inc.	Newton, Mass.	17675	Hamlin Metal Products Corp.	Akron, Ohio
04732	Filttron Co., Inc. Western Div.	Culver City, Cal.	09569	Mallory Battery Co. of Canada, Ltd.	Toronto, Ontario, Canada	17745	Angstrom Prec. Inc.	No. Hollywood, Cal.
04773	Automatic Electric Co.	Northlake, Ill.	09795	Pennsylvania Florecarbon	Clifton Heights, Penn.	17856	Siliconix Inc.	Sunnyvale, Cal.
04796	Sequoia Wire Co.	Redwood City, Cal.	09922	Burdny Corp.	Norwalk, Conn.	17870	McGraw-Edison Co.	Manchester, N. H.
04811	Precision Coil Spring Co.	El Monte, Cal.	10214	General Transistor Western Corp.	Los Angeles, Cal.	18042	Power Design Pacific Inc.	Palo Alto, Cal.
04870	P. M. Motor Company	Westchester, Ill.	10411	Ti-Tal, Inc.	Berkeley, Cal.	18083	Clevite Corp. Semiconductor Div.	Palo Alto, Cal.
04919	Component Mfg. Service Co.	W. Bridgewater, Mass.	10646	Carborundum Co.	Niagara Falls, N. Y.	18324	Signetics Corp.	Sunnyvale, Cal.
05006	Twentieth Century Plastics, Inc.	Los Angeles, Cal.				18476	Ty-Car Mfg. Co., Inc.	Holliston, Mass.
05277	Westinghouse Electric Corp. Semiconductor Dept.	Youngwood, Pa.				18486	TRW Elect. Comp. Div.	Des Plaines, Ill.

00015-49
Revised: May, 1970

From: Handbook Supplements
H4-1 Dated January 1970

CODE LIST OF MANUFACTURERS (Continued)

Code No.	Manufacturer	Address	Code No.	Manufacturer	Address	Code No.	Manufacturer	Address
19644	LRC Electronics	Horseheads, N. Y.	71482	C. P. Clare & Co.	Chicago, Ill.	78452	Thompson-Bremer & Co.	Chicago, Ill.
19701	Electra Mfg. Co.	Independence, Kansas	71590	Centralab Div. of Globe Union Inc.	Milwaukee, Wis.	78471	Tilley Mfg. Co.	San Francisco, Cal.
20183	General Atronics Corp.	Philadelphia, Pa.	71616	Cornish Plastics Co.	Chicago, Ill.	78488	Stackpole Carbon Co.	St. Marys, Pa.
21226	Executone, Inc.	Long Island City, N. Y.	71700	Cornish Wire Co., The	New York, N. Y.	78493	Standard Thomson Corp.	Waltham, Mass.
21355	Fafnir Bearing Co., The	New Britain, Conn.	71707	Coto Coil Co., Inc.	Providence, R. I.	78553	Tinnerman Products, Inc.	Cleveland, Ohio
21520	Fansteel Metallurgical Corp.	N. Chicago, Ill.	71744	Chicago Miniature Lamp Works	Chicago, Ill.	78790	Transformer Engineers	San Gabriel, Cal.
23020	General Reed Co.	Metuchen, N. J.	71785	Cinch Mfg. Co.	Chicago, Ill.	78947	Ucinite Co.	Newtonville, Mass.
23042	Texscan Corp.	Indianapolis, Ind.	71984	Howard B. Jones Div.	Chicago, Ill.	79136	Wenco Mfg. Co.	Long Island City, N. Y.
23783	British Radio Electronics Ltd.	Washington, D.C.	72136	Dow Corning Corp.	Midland, Mich.	79142	Veeder Root, Inc.	Hartford, Conn.
24455	G. E. Lamp Division, Neia Park	Cleveland, Ohio	72619	Electro Motive Mfg. Co., Inc.	Willimantic, Conn.	79251	Wenco Mfg. Co.	Chicago, Ill.
24655	General Radio Co.	West Concord, Mass.	72619	Electro Motive Mfg. Co., Inc.	Willimantic, Conn.	79272	Continental-Wirt Electronics Corp.	Philadelphia, Pa.
24681	Memcor Inc., Comp. Div.	Huntington, Ind.	72619	Dialight Corp.	Brooklyn, N. Y.	79963	Zierick Mfg. Corp.	New Rochelle, N. Y.
26365	Gries Reproducer Corp.	New Rochelle, N. Y.	72656	Indiana General Corp.	Keasby, N. J.	80031	Mepco Division of Sessions Clock Co.	Morristown, N. J.
26462	Grubert File Co. of America, Inc.	Carlstadt, N. J.	72699	General Instrument Corp.	Newark, N. J.	80033	Prestole Corp.	Toledo, Ohio
26851	Compac/Hollister Co.	Hollister, Cal.	72765	Cap Division	Newark, N. J.	80120	Schnitzer Alloy Products Co.	Elizabeth, N. J.
26992	Hamilton Watch Co.	Lancaster, Pa.	72825	Drake Mfg. Co.	Harwood Heights, Ill.	80131	Electronic Industries Association	Standard tube or semi-conductor device, any manufacturer.
28480	Hewlett-Packard Co.	Palo Alto, Cal.	72928	Hugh H. Eby Inc.	Philadelphia, Pa.	80207	Unimax Switch, Div. Maxon Electronics Corp.	Wallingford, Conn.
28520	Heyman Mfg. Co.	Kenilworth, N. J.	72962	Elastic Stop Nut Corp.	Union, N. J.	80223	United Transformer Corp.	New York, N. Y.
30817	Instrument Specialties Co., Inc.	Little Falls, N. J.	72964	Robert M. Hadley Co.	Los Angeles, Cal.	80248	Oxford Electric Corp.	Chicago, Ill.
33173	G. E. Receiving Tube Dept.	Owensboro, Ky.	72982	Erie Technological Products, Inc.	Erie, Pa.	80294	Bourns Inc.	Riverside, Cal.
35434	Lectrohm Inc.	Chicago, Ill.	73061	Hansen Mfg. Co., Inc.	Princeton, Ind.	80411	Arco Div. of Robertshaw Controls Co.	Columbus, Ohio
36196	Stanwyck Coil Products, Ltd.	Hawkesbury, Ontario, Canada	73076	H. M. Harper Co.	Chicago, Ill.	80486	All Star Products Inc.	Defiance, Ohio
36287	Cunningham, W. H. & Hill, Ltd.	Toronto, Ontario, Canada	73138	Helipot Div. of Beckman Inst., Inc.	Fullerton, Cal.	80509	Avery Label Co.	Monrovia, Cal.
37942	P. R. Mallory & Co., Inc.	Indianapolis, Ind.	73293	Hughes Products Division of Hughes Aircraft Co.	Newport Beach, Cal.	80583	Hammarlund Co., Inc.	Mars Hill, N. C.
39543	Mechanical Industries Prod. Co.	Akron, Ohio	73445	Amperex Elect. Co.	Hicksville, L. I., N. Y.	80640	Stevens, Arnold, Co., Inc.	Boston, Mass.
40920	Miniature Precision Bearings, Inc.	Keene, N. H.	73506	Braley Semiconductor Corp.	New Haven, Conn.	80813	Dimco Gray Co.	Dayton, Ohio
40931	Honeywell Inc.	Minneapolis, Minn.	73559	Carling Electric, Inc.	Hartford, Conn.	81030	International Inst. Inc.	Orange, Conn.
42190	Muter Co.	Chicago, Ill.	73586	Circle F Mfg. Co.	Trenton, N. J.	81073	Grayhill Co.	LaGrange, Ill.
43990	C. A. Norgren Co.	Englewood, Colo.	73682	George K. Garrett Co., Div. MSL Industries, Inc.	Philadelphia, Pa.	81095	Triad Transformer Corp.	Venice, Cal.
44655	Ohmite Mfg. Co.	Skokie, Ill.	73734	Federal Screw Products, Inc.	Chicago, Ill.	81312	Winchester Elec. Div. Litton Ind., Inc.	Oakville, Conn.
46384	Penn Eng. & Mfg. Corp.	Doylestown, Pa.	73743	Fischer Special Mfg. Co.	Cincinnati, Ohio	81349	Military Specification	
47904	Polaroid Corp.	Cambridge, Mass.	73793	General Industries Co., The	Elyria, Ohio	81483	International Rectifier Corp.	El Segundo, Cal.
48620	Precision Thermometer & Inst. Co.	Southampton, Pa.	73846	Goshen Stamping & Tool Co.	Goshen, Ind.	81541	Airpax Electronics, Inc.	Cambridge, Maryland
49556	Microwave & Power Tube Div.	Waltham, Mass.	73899	JFD Electronics Corp.	Brooklyn, N. Y.	81860	Barry Controls, Div. Barry Wright Corp.	Watertown, Mass.
52090	Rowan Controller Co.	Westminster, Md.	73905	Jennings Radio Mfg. Corp.	San Jose, Cal.	82042	Carter Precision Electric Co.	Skokie, Ill.
52983	HP Co., Med. Elec. Div.	Waltham, Mass.	73957	Groove-Pin Corp.	Ridgefield, N. J.	82047	Sperti Faraday Inc., Copper Hewitt Electric Div.	Hoboken, N. J.
54294	Shallcross Mfg. Co.	Selma, N. C.	74276	Signalite Inc.	Neptune, N. J.	82116	Electric Regulator Corp.	Norwalk, Conn.
55026	Simpson Electric Co.	Chicago, Ill.	74455	J. H. Winns, and Sons	Winchester, Mass.	82142	Jeffers Electronics Division of Speer Carbon Co.	Du Bois, Pa.
55933	Sonotone Corp.	Elmsford, N. Y.	74861	Industrial Condenser Corp.	Chicago, Ill.	82170	Fairchild Camera & Inst. Corp., Space & Defense Systems Div.	Paramus, N. J.
55938	Raytheon Co. Commercial Apparatus & System Div.	So. Norwalk, Conn.	74868	R. F. Products Division of Amphenol-Borg Electronic Corp.	Danbury, Conn.	82209	Magurie Industries, Inc.	Greenwich, Conn.
56137	Spaulding Fibre Co., Inc.	Tonawanda, N. Y.	74970	E. F. Johnson Co.	Waseca, Minn.	82219	Sylvania Electric Prod., Inc.	Emporium, Pa.
56289	Sprague Electric Co.	North Adams, Mass.	75042	International Resistance Co.	Philadelphia, Pa.	82376	Astron Corp.	East Newark, Harrison, N. J.
58474	Superior Elect. Co.	Bristol, Conn.	75263	Keystone Carbon Co., Inc.	St. Marys, Pa.	82389	Switchcraft, Inc.	Chicago, Ill.
59446	Telex Corp.	Tulsa, Okla.	75378	CTS Knights, Inc.	Sandwich, Ill.	82647	Metals & Controls Inc., Spencer Products	Attleboro, Mass.
59730	Thomas & Betts Co.	Elizabeth, N. J.	75382	Kulka Electric Corp.	Mt. Vernon, N. Y.	82768	Phillips-Advance Control Co.	Joliet, Ill.
60741	Triplet Electrical Inst. Co.	Bluffton, Ohio	75818	Lenz Electric Mfg. Co.	Chicago, Ill.	82866	Research Products Corp.	Madison, Wis.
61775	Union Switch and Signal Div. of Westinghouse Air Brake Co.	Pittsburgh, Pa.	75915	Littlefuse, Inc.	Des Plaines, Ill.	82877	Rolton Mfg. Co., Inc.	Woodstock, N. Y.
62119	Universal Electric Co.	Owosso, Mich.	76005	Lord Mfg. Co.	Erie, Pa.	82893	Vector Electronic Co.	Glendale, Cal.
63743	Ward-Leonard Electric Co.	Mt. Vernon, N. Y.	76210	L. W. Marwedel	San Francisco, Cal.	83058	Carr Fastener Co.	Cambridge, Mass.
64959	Western Electric Co., Inc.	New York, N. Y.	76433	General Instrument Corp., Micamold Division	Newark, N. J.	83086	New Hampshire Ball Bearing, Inc.	Peterborough, N. H.
65092	Weston Inst. Inc. Weston-Newark	Newark, N. J.	76487	James Millen Mfg. Co., Inc.	Malden, Mass.	83125	General Instrument Corp., Capacitor Div.	Darlington, S. C.
66295	Wittek Mfg. Co.	Chicago, Ill.	76493	J. W. Miller Co.	Los Angeles, Cal.	83148	ITT Wire and Cable Div.	Los Angeles, Cal.
66346	Minnesota Mining & Mfg. Co. Revere Mincom Div.	St. Paul, Minn.	76530	Cinch-Monadnock, Div. of United Carr Fastener Corp.	San Leandro, Cal.	83186	Victory Eng. Corp.	Springfield, N. J.
70276	Allen Mfg. Co.	Hartford, Conn.	76545	Mueller Electric Co.	Cleveland, Ohio	83298	Bendix Corp., Red Bank Div.	Red Bank, N. J.
70309	Allied Control	New York, N. Y.	76703	National Union	Newark, N. J.	83315	Hubbell Corp.	Mundelein, Ill.
70318	Allmetal Screw Product Co., Inc.	Garden City, N. Y.	76854	Oak Manufacturing Co.	Crystal Lake, Ill.	83324	Rosan Inc.	Newport Beach, Cal.
70417	Amplex, Div. of Chrysler Corp.	Detroit, Mich.	77068	The Bendix Corp., Electrodynamics Div.	N. Hollywood, Cal.	83330	Smith, Herman H., Inc.	Brooklyn, N. Y.
70485	Atlantic India Rubber Works, Inc.	Chicago, Ill.	77075	Pacific Metals Co.	San Francisco, Cal.	83332	Tech Labs	Palisades Park, N. Y.
70563	Amperite Co., Inc.	Union City, N. J.	77221	Phaostran Instrument and Electronic Co.	So. Pasadena, Cal.	83385	Central Screw Co.	Chicago, Ill.
70674	ADC Products Inc.	Minneapolis, Minn.	77252	Philadelphia Steel and Wire Corp.	Philadelphia, Pa.	83501	Gavitt Wire and Cable Co., Div. of Amerace Corp.	Brookfield, Mass.
70903	Belden Mfg. Co.	Chicago, Ill.	77342	American Machine & Foundry Co. Potter & Brumfield Div.	Princeton, Ind.	83594	Burroughs Corp., Electronic Tube Div.	Plainfield, N. J.
70998	Bird Electric Corp.	Cleveland, Ohio	77630	TRW Electronic Components Div.	Camden, N. J.	83740	Union Carbide Corp., Consumer Prod. Div.	New York, N. Y.
71002	Birnbach Radio Co.	New York, N. Y.	77638	General Instrument Corp., Rectifier Division	Brooklyn, N. Y.	83777	Model Eng. and Mfg., Inc.	Huntington, Ind.
71034	Bliley Electric Co., Inc.	Erie, Pa.	77764	Resistance Products Co.	Harrisburg, Pa.	83821	Lloyd Scruggs Co.	Festus, Mo.
71041	Boston Gear Works Div. of Murray Co. of Texas	Quincy, Mass.	78189	Rubbercraft Corp. of Calif.	Torrance, Cal.	83942	Aeronautical Inst. & Radio Co.	Lodi, N. J.
71218	Bud Radio, Inc.	Willoughby, Ohio	78277	Shakeproof Division of Illinois Tool Works	Elgin, Ill.	84171	Arco Electronics Inc.	Great Neck, N. Y.
71279	Cambridge Thermionics Corp.	Cambridge, Mass.	78283	Sigma	So. Braintree, Mass.	84396	A. J. Giesener Co., Inc.	San Francisco, Cal.
71286	Camloc Fastener Corp.	Paramus, N. J.	78290	Signal Indicator Corp.	New York, N. Y.	84411	TRW Capacitor Div.	Ogallala, Neb.
71313	Cardwell Condenser Corp.	Lindenhurst, L. I., N. Y.		Struthers-Dunn Inc.	Pitman, N. J.			
71400	Bussmann Mfg. Div. of McGraw-Edison Co.	St. Louis, Mo.						
71436	Chicago Condenser Corp.	Chicago, Ill.						
71447	Calif. Spring Co., Inc.	Pico-Rivera, Cal.						
71450	CTS Corp.	Elkhart, Ind.						
71468	ITT Cannon Electric Inc.	Los Angeles, Cal.						
71471	Cinema, Div. Aerovox Corp.	Burbank, Cal.						

00015-49
Revised: May, 1970

From: Handbook Supplements
H4-1 Dated January 1970

CODE LIST OF MANUFACTURERS (Continued)

Code No.	Manufacturer	Address	Code No.	Manufacturer	Address	Code No.	Manufacturer	Address
94870	Sarkes Tarzian, Inc.	Bloomington, Ind.	91929	Honeywell Inc., Micro Switch Division	Freeport, Ill.	96095	Hi-Q Div. of Aerovox Corp.	Olean, N. Y.
85454	Boonton Molding Company	Boonton, N.J.	91961	Nahn-Bros. Spring Co.	Oakland, Cal.	96256	Thordarson-Meissner Inc.	Mt. Carmel, Ill.
85471	A. B. Boyd Co.	San Francisco, Cal.	92180	Tru-Connector Corp.	Peabody, Mass.	96296	Solar Mfg. Co.	Los Angeles, Cal.
85474	R. M. Bracamonte & Co.	San Francisco, Cal.	92367	Elgeet Optical Co., Inc.	Rochester, N. Y.	96396	Microswitch, Div. of Minn.-Honeywell	Freeport, Ill.
85660	Koiled Kords, Inc.	Hamden, Conn.	92607	Tensolite Insulated Wire Co., Inc.	Tarrytown, N. Y.	96330	Carlton Screw Co.	Chicago, Ill.
85911	Seamless Rubber Co.	Chicago, Ill.	92702	IMC Magnetics Corp.	Westbury, L.I., N. Y.	96341	Microwave Associates, Inc.	Burlington, Mass.
86174	Fafnir Bearing Co.	Los Angeles, Calif.	92966	Hudson Lamp Co.	Kearney, N. J.	96501	Excel Transformer Co.	Oakland, Cal.
86197	Clifton Precision Products Co., Inc.	Clifton Heights, Pa.	93332	Sylvania Electric Prod. Inc., Semiconductor Div.	Woburn, Mass.	96508	Xcelite, Inc.	Orchard Park, N. Y.
86579	Precision Rubber Products Corp.	Dayton, Ohio	93369	Robbins & Myers Inc.	Pallisades Park, N. J.	96733	San Fernando Elec. Mfg. Co.	San Fernando, Cal.
86684	Radio Corp. of America, Electronic Comp. & Devices Division	Harrison, N. J.	93410	Stemco Controls, Div. of Essex Wire Corp.	Mansfield, Ohio	96881	Thomson Ind. Inc.	Long Island, N. Y.
86928	Seastrom Mfg. Co.	Glendale, Cal.	93632	Waters Mfg. Co.	Culver City, Cal.	97464	Industrial Retaining Ring Co.	Irvington, N. J.
87034	Marco Industries	Anaheim, Cal.	93929	G. V. Controls	Livingston, N. J.	97539	Automatic & Precision Mfg.	Englewood, N. J.
87216	Philco Corporation (Lansdale Division)	Lansdale, Pa.	94137	General Cable Corp.	Bayonne, N. J.	97979	Reon Resistor Corp.	Yonkers, N. Y.
87473	Western Fibrous Glass Products Co.	San Francisco, Cal.	94144	Raytheon Co., Comp. Div., Ind. Comp. Operations	Quincy, Mass.	97983	Litton System Inc., Adler-Westrex Commun. Div.	New Rochelle, N. Y.
87664	Van Waters & Rogers Inc.	San Francisco, Cal.	94148	Scientific Electronics Products, Inc.	Loveland, Colo.	98141	R-Tronics, Inc.	Jamaica, N. Y.
87930	Tower Mfg. Corp.	Providence, R.I.	94154	Wagner Elect. Corp., Tung-Sol Div.	Newark, N. J.	98159	Rubber Teck, Inc.	Gardena, Cal.
88140	Cutler-Hammer, Inc.	Lincoln, Ill.	94197	Curtiss-Wright Corp., Electronics Div.	East Patterson, N. J.	98220	Hewlett-Packard Co., Medical Elec. Div.	Pasadena, Cal.
88220	Gould-National Batteries, Inc.	St. Paul, Minn.	94222	South Chester Corp.	Chester, Pa.	98278	Microdot, Inc.	So. Pasadena, Cal.
88698	General Mills, Inc.	Buffalo, N. Y.	94330	Wire Cloth Products, Inc.	Bellwood, Ill.	98291	Sealectro Corp.	Mamaronech, N. Y.
88698	General Mills, Inc.	Buffalo, N. Y.	94375	Automatic Metal Products Co.	Brooklyn, N. Y.	98376	Zero Mfg. Co.	Burbank, Cal.
89231	Graybar Electric Co.	Oakland, Cal.	94682	Worcester Pressed Aluminum Corp.	Worcester, Mass.	98410	Etc. Inc.	Cleveland, Ohio
89473	G. E. Distributing Corp.	Schenectady, N. Y.	94696	Magnecraft Electric Co.	Chicago, Ill.	98731	General Mills Inc., Electronics Div.	Minneapolis, Minn.
89479	Security Co.	Detroit, Mich.	95023	George A. Philbrick Researchers, Inc.	Boston, Mass.	98734	Paeco Division of Hewlett-Packard Co.	Palo Alto, Cal.
89665	United Transformer Co.	Chicago, Ill.	95146	Alco Elect. Mfg. Co.	Lawrence, Mass.	98821	North Hills Electronics, Inc.	Glen Cove, N. Y.
90030	United Shoe Machinery Corp.	Beverly, Mass.	95236	Allies Products Corp.	Dania, Fla.	98978	International Electronic Research Corp.	Burbank, Cal.
90179	U. S. Rubber Co., Consumer Ind. & Plastics Prod. Div.	Passaic, N. J.	95238	Continental Connector Corp.	Woodside, N. Y.	99109	Columbia Technical Corp.	New York, N. Y.
90365	Belleville Speciality Tool Mfg., Inc.	Belleville, Ill.	95263	Leecraft Mfg. Co., Inc.	Long Island, N. Y.	99313	Varian Associates	Palo Alto, Cal.
90763	United Carr Fastener Corp.	Chicago, Ill.	95265	National Coil Co.	Sheridan, Wyo.	99378	Atlee Corp.	Winchester, Mass.
90970	Bearing Engineering Co.	San Francisco, Cal.	95275	Vitramon, Inc.	Bridgeport, Conn.	99515	Marshall Ind., Capacitor Div.	Monrovia, Cal.
91146	ITT Cannon Elect. Inc., Salem Div.	Salem, Mass.	95348	Gordos Corp.	Bloomfield, N. J.	99707	Control Switch Division, Controls Co. of America	El Segundo, Cal.
91260	Connor Spring Mfg. Co.	San Francisco, Cal.	95354	Methode Mfg. Co.	Rolling Meadows, Ill.	99800	Delevan Electronics Corp.	East Aurora, N. Y.
91345	Miller Dial & Nameplate Co.	El Monte, Cal.	95566	Arnold Engineering Co.	Marengo, Ill.	99848	Wilco Corporation	Indianapolis, Ind.
91418	Radio Materials Co.	Chicago, Ill.	95712	Dage Electric Co., Inc.	Franklin, Ind.	99928	Branson Corp.	Whippany, N. J.
91506	Augat Inc.	Attleboro, Mass.	95984	Siemon Mfg. Co.	Wayne, Ill.	99934	Rembrandt, Inc.	Boston, Mass.
91637	Dale Electronics, Inc.	Columbus, Nebr.	95987	Weckesser Co.	Chicago, Ill.	99942	Hoffman Electronics Corp., Semiconductor Division	El Monte, Cal.
91662	Elco Corp.	Willow Grove, Pa.	96067	Microwave Assoc., West, Inc.	Sunnyvale, Cal.	99957	Technology-Instrument Corp. of California	Newbury Park, Cal.
91673	Epiphone Inc.	New York, N. Y.						
91737	Gremar Mfg. Co., Inc.	Wakefield, Mass.						
91827	K F Development Co.	Redwood City, Cal.						
91886	Malco Mfg., Inc.	Chicago, Ill.						

The following HP Vendors have no number assigned in the latest supplement to the Federal Supply Code for Manufacturers Handbook.

0000F	Malco Tool and Die	Los Angeles, Calif.	000CS	Hewlett-Packard Co., Colorado Springs Div.	Colorado Springs, Colorado	000QQ	Cooltron	Oakland, Cal.
0000Z	Willow Leather Products Corp.	Newark, N. J.	000MM	Rubber Eng. & Development	Hayward, Cal.	000WW	California Eastern Lab	Burlington, Cal.
000AB	ETA	England	000NN	A "N" D Mfg. Co.	San Jose, Cal.	000YY	S.K. Smith Co.	Los Angeles, Cal.
000BB	Precision Instrument Comp. Co.	Van Nuys, Cal.						

SUPPLEMENTAL CODE LIST OF MANUFACTURERS

Code No.	Manufacturer	Address
000LB	Specialty Connector Co.	Indianapolis, Ind.
000LC	Jackson Bros. Ltd.	New York, N. Y.
000LJ	(Relcoa) Relay Co. of America c/o Barnhill Associates	Denver, Colo.
00327	Welwyn International Inc.	Cleveland, Ohio
03911	Clairax Corp.	New York, N. Y.
08988	Skottie Electronics	Archbald, Pennsylvania

00015-49
Revised: May, 1970

From: Handbook Supplements
H4-1 Dated January 1970

hp MANUAL BACKDATING CHANGES

MODEL 652A TEST OSCILLATOR

Manual Serial Prefixed: 623, 632, 812,
826, 911, 954,
0964A.

-hp- Part No. 00652-90002

This manual backdating sheet makes this manual applicable to earlier instruments. Instrument-component values that differ from those in the manual, yet are not listed in the backdating sheet, should be replaced using the part number given in the manual.

Instrument Serial Prefix	Make Manual Changes	Instrument Serial Prefix	Make Manual Changes
632-00250 and below	No. 1	1226A-04170 and below	No. 7
954-02135 and below	No. 2	1226A-04309 and below	No. 8
Blue Instruments	No. 3		
Below 0964A02771	No. 4		
0964A03070 and below	No. 5		
911-01736 and below	No. 6		

CHANGE No. 1

- Delete A2C25*
- Delete A2R46
- Change A2C11 to 200 microfarads, -hp- Part No. 0180-0060.
- Change A2CR5 to a breakdown diode, 7.87 V +/- 2%, -hp- Part No. 1902-0778.
- Change A2Q7 to 2N3393, -hp- Part No. 1854-0218.
- Change A2R25 to 11.75K, -hp- Part No. 0757-0757.

Change circuitry associated with A2Q7 in Figure C-1.

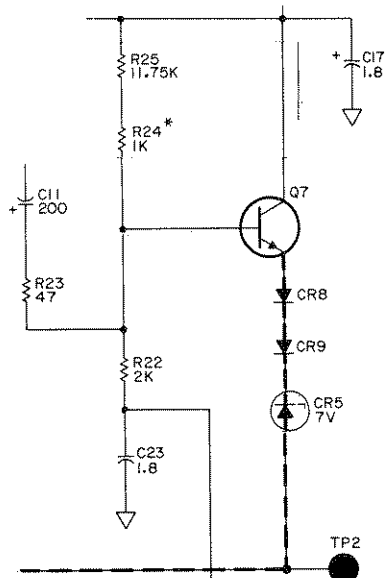

Figure C-1. P/O Oscillator Circuit.

- CHANGE No. 2 Table 7-1, Page 7-9:
 Change the -hp- Part No. of W1 to 8120-0078.
Table 7-1, Page 7-8:
 Change the -hp- Part No. of MP32 to 00651-00202.
Table 7-1, Page 7-7:
 Change the -hp- Part No. of J1 to 1251-0148.
- CHANGE No. 3 Table 7-1, Page 7-8:
 Change the -hp- Part No. of MP29 to 5040-0642
 Change the -hp- Part No. of MP31 to 5060-0739
 Change the -hp- Part No. of MP34 to 5060-0766
 Change the -hp- Part No. of MP35 to 5000-0732
 Change the -hp- Part No. of MP36 to 5000-0733
 Change the -hp- Part No. of MP41 to 5060-0751
 Change the -hp- Part No. of MP42 to 00652-00201
- Table 7-1, Page 7-9:
 Change the -hp- Part No. of Rack Mount Kit to 00652-84401.
- CHANGE No. 4 Table 7-1, Page 7-8:
 Change the -hp- Part No. of MP18 to 1205-0008
 Add Nut: heat sink P/O MP18
Table 7-1, Page 7-9:
 Add Insulator: washer (for MP18)
- CHANGE No. 5 Table 7-1, Page 7-4:
 Change the -hp- Part No. of A1Q2 to 1850-0107
 Change the -hp- Part No. of A1Q3 to 1853-0007
 Change the -hp- Part No. of A1Q5 to 1850-0107
 Change the -hp- Part No. of A1Q6 to 1850-0062
 Change the -hp- Part No. of A1Q7 to 1853-0007
- NOTE: The recommended replacement for
 these five transistors is the 1853-0012 shown
 on Page 7-4.
- CHANGE No. 6 Figure 6-3, Page 6-7/6-8:
 Delete A1CR12 from A1 component locator.
Figure 6-4, Page 6-9/6-10:
 Delete A1CR12 from A1 component locator and schematic.
Table 7-1, Page 7-4:
 Delete A1CR12 from A1 assembly.

CHANGE No. 7

Page 4-3:

Replace Paragraphs 4-29 through 4-32 with the following paragraphs:

4-29. REGULATED POWER SUPPLY.

4-30. The regulated power supply provides all voltages required by the test oscillator circuits. The power supply consists of a +30 volt series regulated supply and a -25 volt series regulated supply which is referenced to the +30 volt circuit.

4-31. The + 30 volt regulated supply is of the conventional series regulator type. The emitter follower A1Q2 is used to increase the loop gain of the circuit, thus improving voltage regulation. The + 30 volt adjustment, A1R4, sets the + 30 volt and - 25 volt supply output level.

4-32. The -25 volt regulated supply is of the conventional series regulator type and operates the same as the +30 volt supply. A current limiter, A1Q7 has been added to limit the load current to a set value. When the load current exceeds the set value, the current limiter conducts, causing the series regulator Q2 to reduce the output voltage level until the load causing an excessive current is removed. Diodes A1CR6 and A1CR7 protect the control transistor, A1Q6, against short circuits between the two voltage supplies, or short circuits in the output of the -25 volt supply.

Page 5-8:

Replace Paragraph 5-26 with the following paragraph:

5-26. Power Supply Voltage Adjustments.

a. Connect dc voltmeter to power supply positive output, connector point 1.(Refer to Figure 6-4.)

b. Adjust A1R4 (+ 30 V adjust) for an indication of + 30 V on dc voltmeter. If A1R4 does not have sufficient range, change A1R5*.

c. Connect dc voltmeter to power supply negative output, connector point 2; dc voltmeter should indicate - 25 V \pm 0.75 V. If negative supply output is not within tolerance, change value of resistor A1R13* to obtain specified output. Decrease value of A1R13* to increase negative supply voltage; increase value of A1R13* to decrease negative supply voltage.

Page 5-9, Figure 5-7 and Page 7-3, Figure 7-2.

Change A1 adjustments as in Figure C-2.

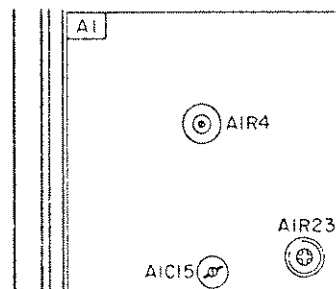

Figure C-2. A1 Adjustments.

Page 5-17, Paragraph 5-51:

Change troubleshooting information Steps 5 through 9 to the following:

- 5 Check the power supply connections to external circuits, and check the resistors in series with the connections (A2 Pins 1, 2, 6 and 7; A3 Pin 4 and 7; A1R17, A1R24, A1R26 and A1R28).
- 6 A procedure for checking the oscillator circuit is given in Paragraph 5-53.
- 7 False if either or both voltages are not correct. If the +30 V was correct in Step 4, check only A1 Pin 7.
- 8
 - a. If only the -25 V supply is inoperative, proceed to branch 9.
 - b. The -25 V supply is referenced to the +30 V. Lift one side of A1R13 to isolate the supplies from each other; if the +30 V supply now operates normally, proceed to Step 9; if it does not, remove external circuits by disconnecting A2 Pins 1 and 6, A3 Pin 7 and A1R17. If the supply now operates, then the trouble is in the external circuits. If the supply still does not operate, check Q1, A1Q2, A1Q3, A1CR1 and A1CR2.
- 9 Isolate the -25 V supply from external circuits by disconnecting A2 Pins 2 and 7, A3 Pin 4 and A1R24, A1R26 and A1R28. If the supply now operates, then the trouble is in the external circuits; if the supply does not operate, check Q2, A1Q5, A1Q6, A1Q7, A1CR3 and A1CR4.

Page 5-21/5-22, Figure 5-11:

Change Step 7 of the troubleshooting tree to 43 V ac at A1 pin 5, 40 V ac at A1 pin 7.

Page 6-3, Figure 6-1:

Change the Regulated Power Supply block diagram as in Figure C-3.

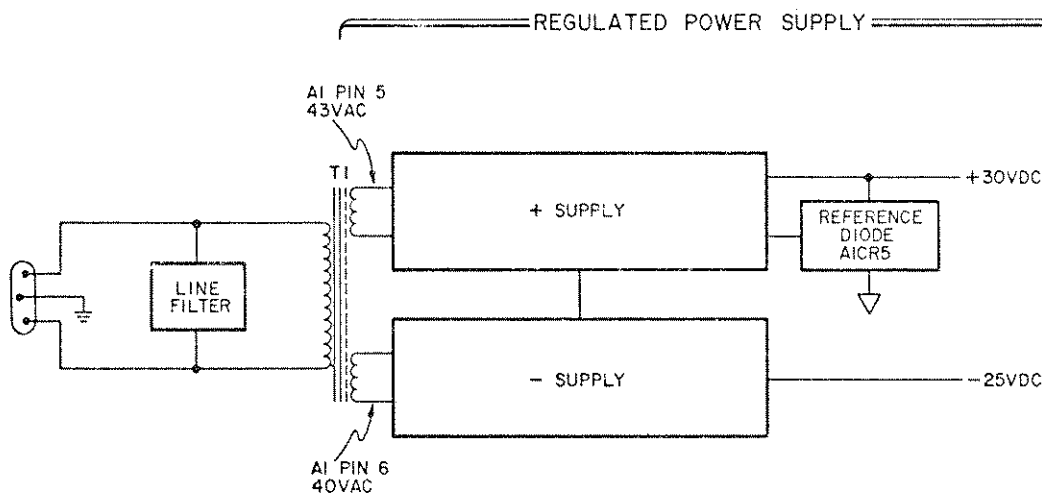

Figure C-3. Power Supply Block Diagram.

Page 6-7/6-8 and 6-9/6-10:

Change the A1 Component Locator drawing as in Figure C-4.

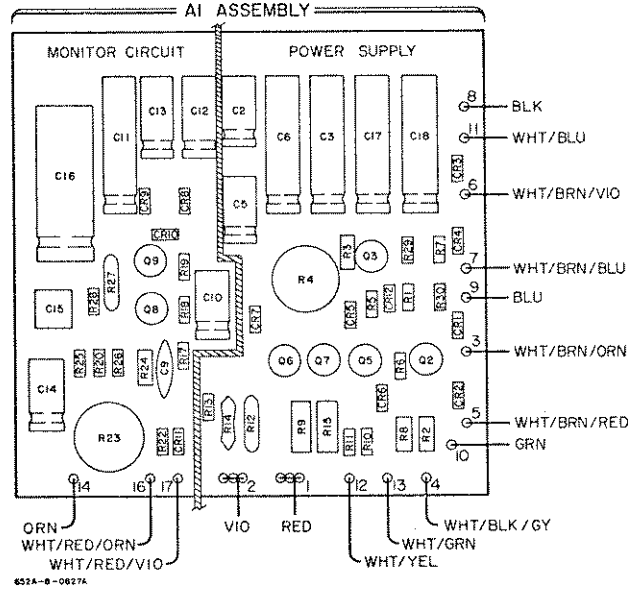

Figure C-4. A1 Component Locator, -hp- Part No. 00652-66502.

Page 6-9/6-10, Figure 6-4:

Change the Power Schematic drawing as in Figure C-5.

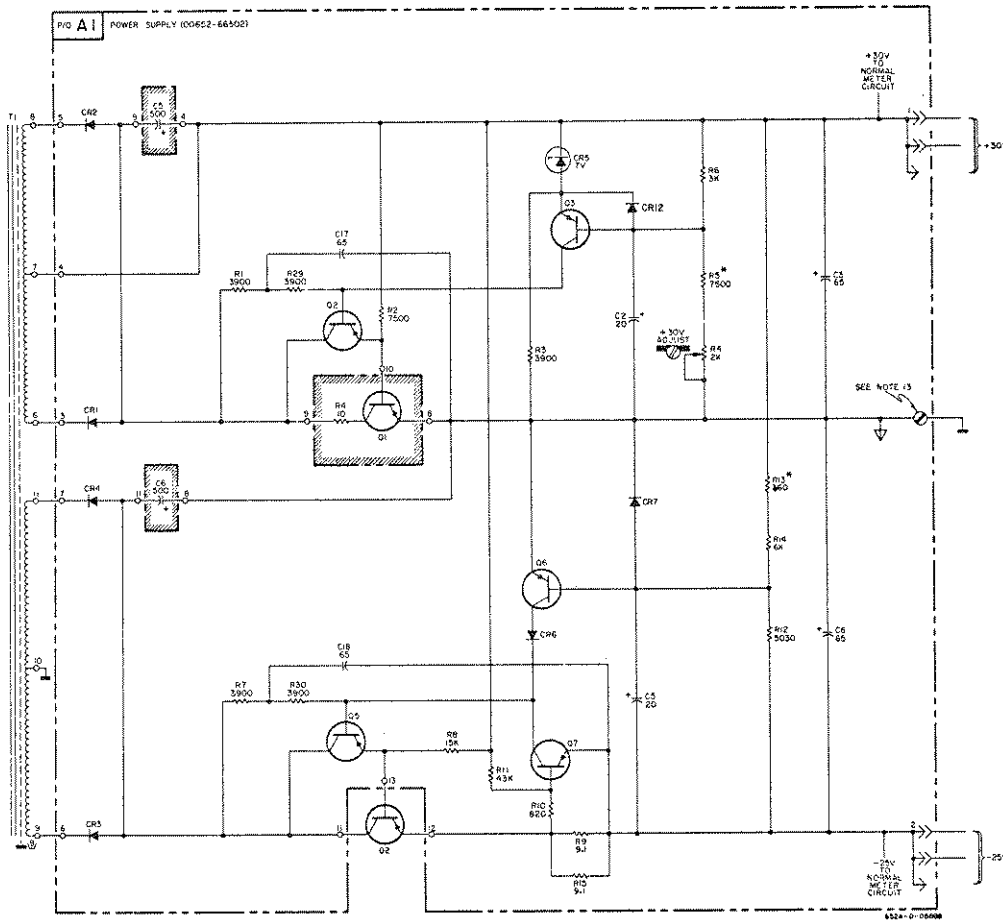

Figure C-5. Power Supply Schematic Drawing.

Change the A1 Replaceable Parts List as in Table C-1.
Change Q1 1854-0063 and Q2 1853-0305 to 1850-0098,
TSTR: Ge PNP.

Table C-1. A1 Replaceable Parts.

REFERENCE DESIGNATOR	-hp- PART NO.	TQ	DESCRIPTION	MFR.	MFR. PART NO.
A1	00652-66502	1	Pc board: power supply	28480	00652-66502
A1C1			Not assigned		
A1C2	0180-0045	2	C: fxd Al elect 20 μ F +75% -10% 25 vdcw	56289	30D206G025 DB2-DSM
A1C3	0180-0149	4	C: fxd Al elect 65 μ F +100% -10% 60 vdcw	56289	(Type 30D) D36978
A1C4			Not assigned		
A1C5	0180-0045		C: fxd Al elect 20 μ F +75% -10% 25 vdcw	56289	30D206G025 DB2-DSM
A1C6	0180-0149		C: fxd Al elect 65 μ F +100% -10% 60 vdcw	56289	(Type 30D) D36978
A1C7, A1C8			Not assigned		
A1C9	0150-0084	4	C: fxd cer 0.1 μ F +80% -20% 50 vdcw	56289	33C41 obd
A1C10	0180-0061	3	C: fxd Al elect 100 μ F +75% -10% 15 vdcw	56289	30D107G015DC2-DSM
A1C11	0180-0062	3	C: fxd Al elect 300 μ F +75% -10% 6 vdcw	56289	30D307G006DF2-DSM
A1C12, A1C13	0180-0058	2	C: fxd Al elect 50 μ F +75% -10% 25 vdcw	56289	30D506G025CC2-DSM
A1C14	0180-0061		C: fxd Al elect 100 μ F +75% -10% 15 vdcw	56289	30D107G015DC2-DSM
A1C15	0121-0127	3	C: var air 1.7 to 14.1 pF	74970	189-505-5
A1C16	0180-0284	2	C: fxd Al elect 200 μ F +75% -10% 30 vdcw	56289	D38559
A1C17, A1C18	0180-0149		C: fxd Al elect 65 μ F +100% -10% 60 vdcw	56289	(Type 30D) D36978
A1CR1 thru A1CR4	1901-0158	4	Diode: Si 200 piv	04713	SR 1353-3 obd
A1CR5	1902-0045	1	Diode: breakdown 7.32 V \pm 2% 400 mW glass	07263	obd
A1CR6, A1CR7	1901-0025	10	Diode: Si 100 mA at +1 V 100 piv 12 pF	03877	SG 817 obd
A1CR8, A1CR9	1901-0347	2	Diode: Si PNP **	-hp- 03877	S3185G obd
A1CR10	1910-0016		Diode: Ge 60 wiv 1 ms	03877	SG 817 obd
A1CR11, A1CR12	1901-0025		Diode: Si 100 mA at +1 V 100 piv 12 pF	03877	
A1Q1			Not assigned		
A1Q2 thru A1Q7	1853-0012	6	TSTR: Si PNP JEDEC Type 2N2904A	04713	2N2904A obd
A1Q8	1854-0071	2	TSTR: Si NPN 2N3391	28480	1854-0071
A1Q9	1854-0042	1	TSTR: Si NPN SM1570	04713	SM1570
A1R1	0683-3925	4	R: fxd comp 3900 Ω \pm 5% 1/4 W	01121	CB3925
A1R2	0686-7525	1	R: fxd comp 7500 Ω \pm 5% 1/2 W	01121	EB7525
A1R3	0687-3921	1	R: fxd comp 3900 Ω \pm 10% 1/2 W	01121	EB3921
A1R4	2100-0090	1	R: var comp lin 2000 Ω \pm 30% 0.15 W	71450	UPM-70RE(-hp-) obd
A1R5*	0683-7525	1	R: fxd comp 7500 Ω \pm 5% 1/4 W	01121	CB7525
A1R6	0683-3025	1	R: fxd comp 3000 Ω \pm 5% 1/4 W	01121	CB3025
A1R7	0683-3925		R: fxd comp 3900 Ω \pm 5% 1/4 W	01121	CB3925
A1R8	0687-1531	1	R: fxd comp 15 K Ω \pm 10% 1/2 W	01121	EB1531
A1R9	0689-0915	2	R: fxd comp carbon 9.1 Ω \pm 5% 1 W	01121	GB91G5
A1R10	0683-8215	2	R: fxd comp 820 Ω \pm 5% 1/4 W	01121	CB8215
A1R11	0683-4335	2	R: fxd comp 43 K Ω \pm 5% 1/4 W	01121	CB4335
A1R12	0757-0039	1	R: fxd met flm 5030 Ω \pm 1% 1/2 W	75042	CEC T-O obd
A1R13*	0683-3615	2	R: fxd comp 360 Ω \pm 5% 1/4 W		
A1R14	0757-1013	1	R: fxd met flm 6000 Ω \pm 1% 1/2 W	75042	CEC T-O obd
A1R15	0689-0915		R: fxd comp carbon 9.1 Ω \pm 5% 1 W	01121	GB91G5
A1R16			Not assigned		
A1R17	0684-1001	1	R: fxd comp 10 Ω \pm 10% 1/4 W	01121	CB1001
A1R18, A1R19	0683-2025	3	R: fxd comp 2000 Ω \pm 5% 1/4 W	01121	CB2025
A1R20	0683-3935	2	R: fxd comp 39 K Ω \pm 5% 1/4 W	01121	CB3935
A1R21			Not assigned		
A1R22*	0683-8215		R: fxd comp 820 Ω \pm 5% 1/4 W	01121	CB8215
A1R23	2100-0282	1	R: var ww 2000 Ω \pm 20% 1-1/2 W	11236	110 obd
A1R24	0687-1031	1	R: fxd comp 10 K Ω \pm 10% 1/2 W	01121	EB1031 obd
A1R25	0684-1011	2	R: fxd comp 100 Ω \pm 10% 1/4 W	01121	CB1011
A1R26	0683-1535	1	R: fxd comp 15 K Ω \pm 5% 1/4 W	01121	CB1535
A1R27	0698-0026	1	R: fxd met flm 1690 Ω \pm 1% 1/2 W	19701	MF7C T-O obd
A1R28	0683-5115	1	R: fxd comp 510 Ω \pm 5% 1/4 W	01121	CB5115
A1R29, A1R30	0683-3925		R: fxd comp 3900 Ω \pm 5% 1/4 W	01121	CB3925

CHANGE No. 8

Page 5-9, Figure 5-7:
Change A2 adjustments as in Figure C-6.

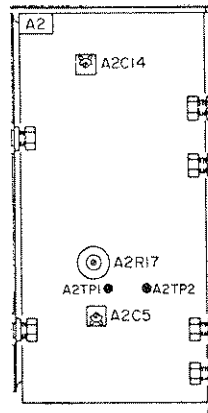

Figure C-6. A2 Adjustments.

Page 5-11:

Replace Paragraphs 5-29(d), (h), (i) and 5-30(c), (d), and (e) with the following:

5-29. Frequency Dial Calibration.

d. Record A2TP2 voltage. This voltage should be between -0.32 V to -0.40 V in a calibrated instrument; however, at this point in the Calibration Procedure, it could be up to 200 mV outside this range. It is not necessary to correct the voltage as this will be done later in the procedure (Paragraph 5-30).

h. Record A2TP2 voltage.

i. Set 652A FREQUENCY dial to 10. Readjust SIC2 and SIC7 alternately until counter indicates frequency of 10 kHz and A2TP2 voltage equals voltage recorded in Step h.

5-30. X1K Range Adjustments.

c. AC Voltmeter should indicate 110 ± 10 mV rms. If A2TP1 voltage is not in tolerance, change value of A2R16* to bring voltage within specified limits (increase value of A2R16* to decrease A2TP1 voltage, and vice versa). Do not solder A2R16* in place at this time.

d. Note dc voltage on A2TP2, which should be within -400 mV to -320 mV. If not, change the value of S1R5* and S1R18* simultaneously (See Table 5-6) until A2TP2 voltage is within tolerance and frequency is 1 kHz. Do not solder the resistors in place.

e. Repeat Steps c and d of this paragraph (if necessary) until A2TP1, A2TP2 and the frequency are all within tolerance. Solder A2R16*, S1R5* and S1R18* in place.

Replace Paragraph 5-53(c) with the following:

5-53. Troubleshooting the Oscillator Circuit.

c. If there is no signal at A2 Pin 5, isolate the Peak Detector by lifting one side of A2C11 and the emitter of A2Q7. If the oscillator comes on, check the Peak Detector components. If there is no apparent fault in the Peak Detector, it is possible that A2R16* may have an incorrect value, this is likely to occur if other components (such as A2CR6, A2CR7, A2Q2, and A2Q3) have been replaced. To check this reconnect the peak detector, replace A2R16* with a 500 ohm potentiometer, switch the 652A to the X1K range and vary the value of the potentiometer, while tuning the dial over its entire range.

Change A2 Component Locator drawings as in Figure C-7.

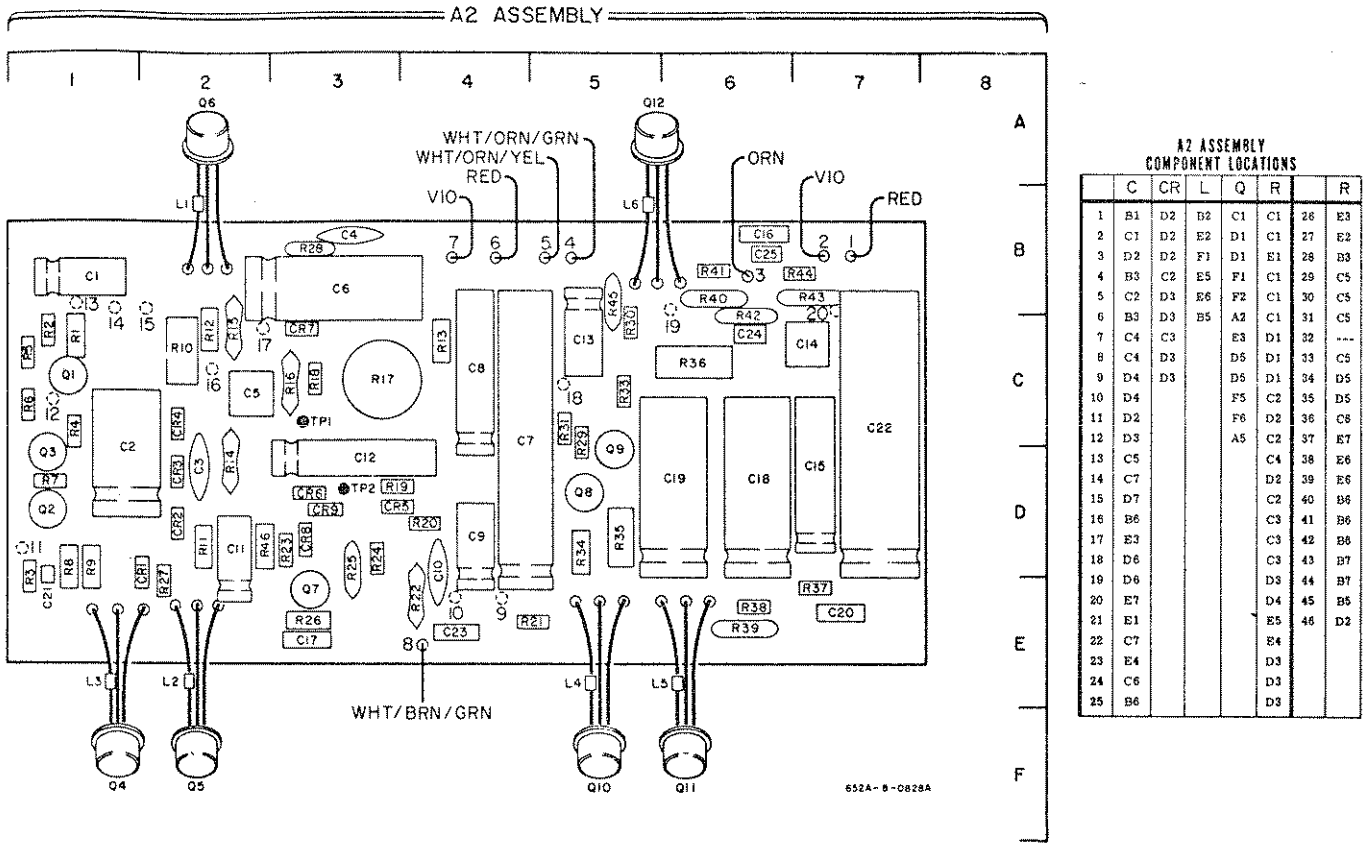

Figure C-7. A2 Component Locator.

Page 6-5/6-6, Figure 6-2:
Change Oscillator Schematic and Component Locator as in
Figure C-8.

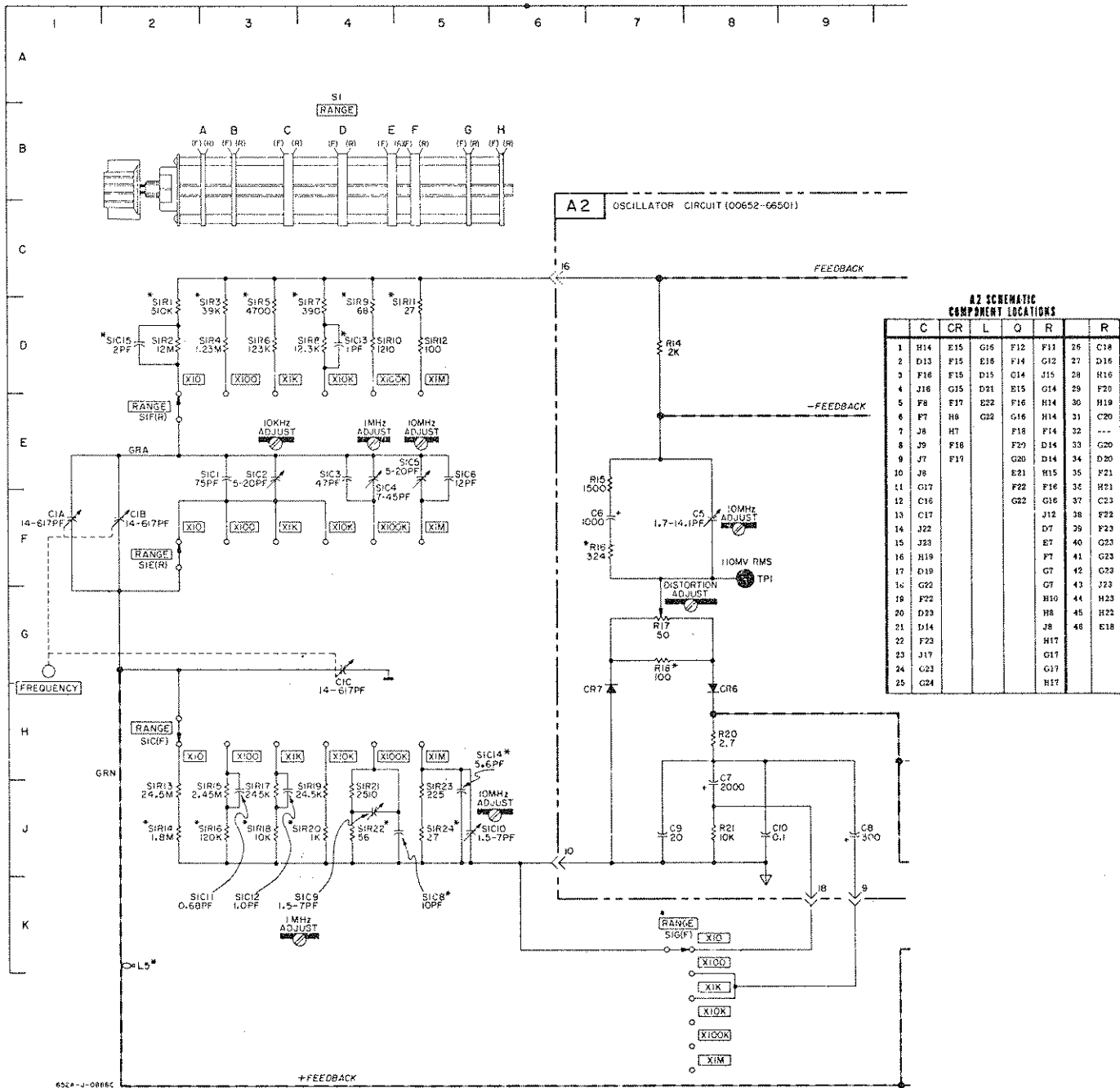

Figure C-8. Oscillator Schematic.

Page 7-6, Table 7-1:
Change A2R16 from 2100-2604 to 0757-0410, 301 Ω,
± 1%, 1/8 W.
Add A2R18* 0684-1011, 100 Ω, ± 10%, 1/4 W.
Delete A2R47.

FEEDTHRU TERMINATION OPERATING NOTE

1. The -hp- Models 11048C, 11094B and 11095A Feedthru Terminations can be used with any device having an input or output impedance of 50 ohms, 75 ohms or 600 ohms respectively. (See Table of Specifications).

2. A view of the 11048C is shown in Figure 1. Figure 2 shows an exploded view along with parts identification. Table 2 gives a description of terminating resistor R1 for each of the feedthru terminations.

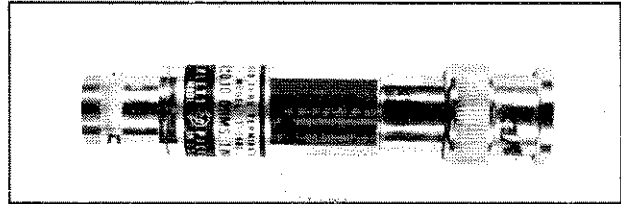

Figure 1. 11048C 50 Ohm Feedthru Termination.

Table 1. Specifications.

	11048C	11094B	11095A
Input:	50 Ω \pm .2 %	75 Ω \pm .2 %	600 Ω \pm 1 %
Output:	50 Ω \pm .2 %	75 Ω \pm .2 %	600 Ω \pm 1 %
Power Rating:	1.00 Watts	1.00 Watts	0.25 Watts

Table 2. Resistor R1; Fixed Metal Film.

Model	Description	-hp- Part No.
11048C	R: 50 Ω \pm .1 % 1 W	0698-8155
11094B	R: 75 Ω \pm .1 % 1 W	0698-8154
11095A	R: 600 Ω \pm 1/4 % 1/4 W	0968-6261

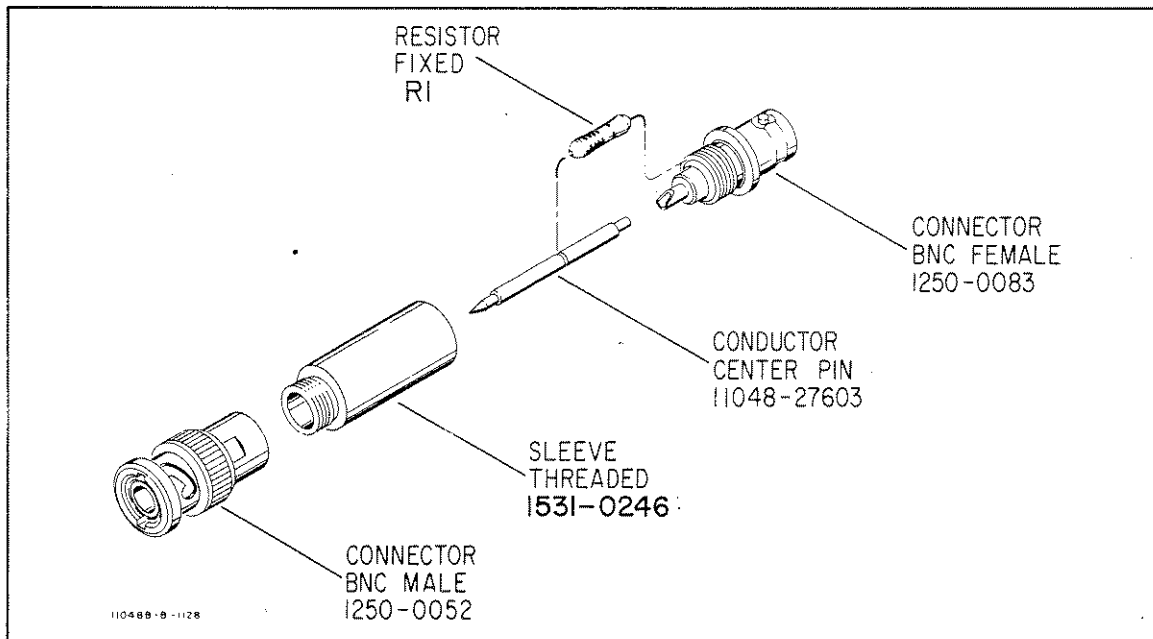

Figure 2. Exploded View.

11048C, 11094, 11095A-90004

November 1971

Printed in U.S.A.



FOR MORE INFORMATION, CALL YOUR LOCAL HP SALES OR SERVICE OFFICE or East (201) 265-5000 • Midwest (312) 255-9800 • South (404) 955-1500 • West (213) 970-7500 or (415) 968-9200; OR WRITE, Hewlett-Packard, 1501 Page Mill Road, Palo Alto, California 94304. IN EUROPE, CALL YOUR LOCAL HP SALES OR SERVICE OFFICE OR WRITE, Hewlett-Packard S.A., 7, rue du Bois-du-Lan, P.O. Box CH-1217 MEYRIN 2 -Geneva, Switzerland. IN JAPAN, Yokogawa-Hewlett-Packard Ltd., 9-1, Takakura-cho, Hachioji-shi, Tokyo, Japan 192.



CERTIFICATION

Hewlett-Packard Company certifies that this product met its published specifications at the time of shipment from the factory. Hewlett-Packard further certifies that its calibration measurements are traceable to the United States National Bureau of Standards, to the extent allowed by the Bureau's calibration facility, and to the calibration facilities of other International Standards Organization members.

WARRANTY

This Hewlett-Packard product is warranted against defects in material and workmanship for a period of one year from date of shipment [except that in the case of certain components listed in Section I of this manual, the warranty shall be for the specified period]. During the warranty period, Hewlett-Packard Company will, at its option, either repair or replace products which prove to be defective.

For warranty service or repair, this product must be returned to a service facility designated by -hp-. Buyer shall prepay shipping charges to -hp- and -hp- shall pay shipping charges to return the product to Buyer. However, Buyer shall pay all shipping charges, duties, and taxes for products returned to -hp- from another country.

Hewlett-Packard warrants that its software and firmware designated by -hp- for use with an instrument will execute its programming instructions when properly installed on that instrument. Hewlett-Packard does not warrant that the operation of the instrument, or software, or firmware will be uninterrupted or error free.

LIMITATION OF WARRANTY

The foregoing warranty shall not apply to defects resulting from improper or inadequate maintenance by Buyer, Buyer-supplied software or interfacing, unauthorized modification or misuse, operation outside of the environmental specifications for the product, or improper site preparation or maintenance.

NO OTHER WARRANTY IS EXPRESSED OR IMPLIED. HEWLETT-PACKARD SPECIFICALLY DISCLAIMS THE IMPLIED WARRANTIES OF MERCHANTABILITY AND FITNESS FOR A PARTICULAR PURPOSE.

EXCLUSIVE REMEDIES

THE REMEDIES PROVIDED HEREIN ARE BUYER'S SOLE AND EXCLUSIVE REMEDIES. HEWLETT-PACKARD SHALL NOT BE LIABLE FOR ANY DIRECT, INDIRECT, SPECIAL, INCIDENTAL, OR CONSEQUENTIAL DAMAGES, WHETHER BASED ON CONTRACT, TORT, OR ANY OTHER LEGAL THEORY.

ASSISTANCE

Product maintenance agreements and other customer assistance agreements are available for Hewlett-Packard products.

For any assistance, contact your nearest Hewlett-Packard Sales and Service Office. Addresses are provided at the back of this manual.

MANUAL CHANGES

-hp- MODEL 652A

TEST OSCILLATOR

Manual Part Number 00652-90006

■ New or Revised Item

ERRATA

- ✓ Page 1-2, Table 1-1. Change Power Requirements to read, "115 V \pm 10%, 48 to 440 Hz, or 230 V \pm 10%, 48 to 66 Hz, 30 VA nominal, 35 VA maximum.
- ✓ Page 2-1. Change Paragraph 2-6 to read, "the Model 652A will operate from a power source of 115 V \pm 10%, 48 to 440 Hz, or 230 V \pm 10%, 48 to 66 Hz. Line Voltage selection is made by setting the rear panel LINE SELECTOR switch. A 0.4 ampere slow-blow fuse is used for both 115 V and 230 V operation.
- ✓ Page 2-1, Paragraph 2-14. Delete from last sentence "and instructions furnished with your instrument," and add "-hp- part number 5060-8740."
- ✓ Page 5-11, Paragraph 5-29, Step d and Step h. Change \pm 5 mV to \pm 10 mV.
- ✓ Page 6-5/6-6, Figure 6-2. Change A2R47* to 274 Ω .
- ✓ Page 6-7/6-8, Figure 6-3. Change A3C4* to 47 μ F.
Change C11 to 1.7 - 14.1 pF.
- ✓ Page 6-9/6-10, Figure 6-4. Delete A1R32 and connect A1U2 pin 3 to junction of A1R31 and A1CR20. Add a connection from A1U1 pin 4 to ground.
- ✓ Page 7-5, Table 7-1. Delete A1R32.
- ✓ Page 7-6, Table 7-1. Change A2CR4 to 1901-0033.
Change A2CR6, CR7 to 1901-0014.
- ✓ Page 7-7, Table 7-1. Change A2R47* to 0757-0490, 274 Ω .
Change A3C11 to 0121-0127, 1.7 - 14.1 pF.
- ✓ Page 7-9, Table 7-1. Change MP18 to 1205-0220.
Change R1 to 0683-2235, 22 k Ω 5%.
- ✓ Page 7-10, Table 7-1. Change S1C8 to 0150-0045, 8.2 pF.
Change S1C14* to 0140-0002, 10 pF.

Page 7-9/7-10. Delete the asterisk (*), which denotes a component that may be padded, on the following components:

C3*, C5*	0140-0146
C1*, C13*, C17*	0150-0011
C16*, C18*	0150-0029
C9*, C11*	0160-0763
C15*, C7*	0160-2322
R2*	0686-1545
R10*	0686-1855

CHANGES MADE 27 DEC 82 - DMK

- ✓ Page 7-9. Delete MP15 (Fuse Holder) 2110-0359. Add to Chassis Components list the following items:

-hp- Part No.	TQ	Description
2110-0564	1	Fuseholder
2110-0565	1	Cap-Fuseholder
2110-0569	1	Nut-Fuseholder
1400-0090	1	Washer

- ✓ Page 7-10. Change S3 Power Switch to 3101-2147.

27 November 1979

Supplement A for 00652-90006