



DC POWER SUPPLY

SCR-10 SERIES

MODEL 6477C/ 83C

ALSO COVERS MODEL 6479C

OPERATING AND SERVICE MANUAL
FOR SERIALS 1125A-0101 AND ABOVE *

*For Serials Above 1125A-0101
a change page may be included.

100 Locust Avenue, Berkeley Heights, New Jersey 07922

HP Part No. 06477-90002

Printed: September, 1971

TABLE OF CONTENTS

Section	Page
I GENERAL INFORMATION	1-1
1-1 Description	1-1
1-5 Specifications	1-1
1-7 Options	1-2
1-9 Accessories	1-2
1-11 Instrument/Manual Identification	1-2
1-14 Ordering Additional Manuals	1-2
 II INSTALLATION	 2-1
2-1 Initial Inspection	2-1
2-3 Mechanical Check	2-1
2-5 Electrical Check	2-1
2-7 Installation Data	2-1
2-9 Location	2-1
2-11 Outline Diagram	2-1
2-13 Rack Mounting	2-2
2-15 Input Power Requirements	2-2
2-20 208/230Vac Conversion	2-2
2-22 380/400Vac Conversion	2-2
2-30 50Hz Ac Input (Option 005)	2-3
2-32 Repackaging for Shipment	2-3
 III OPERATING INSTRUCTIONS	 3-1
3-1 Turn-On Checkout Procedure	3-1
3-3 Operating Modes	3-2
3-5 Normal Operating Mode	3-2
3-7 Constant Voltage	3-2
3-9 Constant Current	3-2
3-11 No Load Operation	3-3
3-13 Output Ranges – Models 6466C and 6483C Only	3-3
3-15 Connecting Load	3-3
3-18 Grounding	3-3
3-21 Operation Beyond Rated Output	3-3
3-23 Protection Circuits	3-3
3-25 Optional Operating Modes	3-3
3-26 Remote Programming, Constant Voltage	3-3
3-34 Remote Programming, Constant Current	3-4
3-40 Remote Sensing	3-5
3-45 Auto-Parallel Operation	3-6
3-48 Auto-Series Operation	3-6
3-53 Battery Charging	3-7
3-58 Battery Discharging	3-8
3-62 Special Operating Considerations	3-8
3-63 Pulse Loading	3-8

SECTION I GENERAL INFORMATION

1-1 DESCRIPTION

1-2 This power supply, Figure 1-1, is completely transistorized and is suitable for high power applications which require a dc source with a moderate degree of regulation. The supply is a constant voltage/constant current type that will furnish full rated output voltage at the maximum rated output current or can be continuously adjusted throughout most of the output range. The front panel CURRENT controls can be used to establish the output current limit (overload or short circuit) when the supply is used as a constant voltage source and the VOLTAGE controls can be used to establish the voltage limit (ceiling) when the supply is used as a constant current source. The supply will automatically cross over from constant voltage to constant current operation and vice versa if the output current or voltage exceeds these preset limits.

1-3 Many protection circuits are included in the supply to protect the regulator SCR's against excessive current or voltage and to protect the user's load. The supply also contains the front panel trouble lamps associated with some of the protection circuits.

1-4 Output voltage and current are continuously monitored on two front panel meters. Input power is connected to a four pin connector on the rear of the unit. The output terminals are heavy busbars also mounted at the rear of the unit. Terminal strips at the rear of the unit allow ease in expanding the operational capabilities of the instrument. A brief description of these capabilities is given below:

a. *Remote Programming.* The power supply output voltage or current may be programmed (controlled) from a remote location by means of an external voltage source or resistance.

b. *Remote Sensing.* The degradation in regulation which occurs at the load due to voltage drop in the load leads can be reduced by using the power supply in the remote sensing mode of operation.

c. *Auto-Series Operation.* Two power supplies may be used in series when a higher output voltage is required in the constant voltage mode of operation or when greater voltage compliance is required in the constant current mode of operation. Auto-Series operation permits one-knob control of the total output voltage from a "master" supply.

d. *Auto-Parallel Operation.* The power supply may be operated in parallel with another unit when greater output

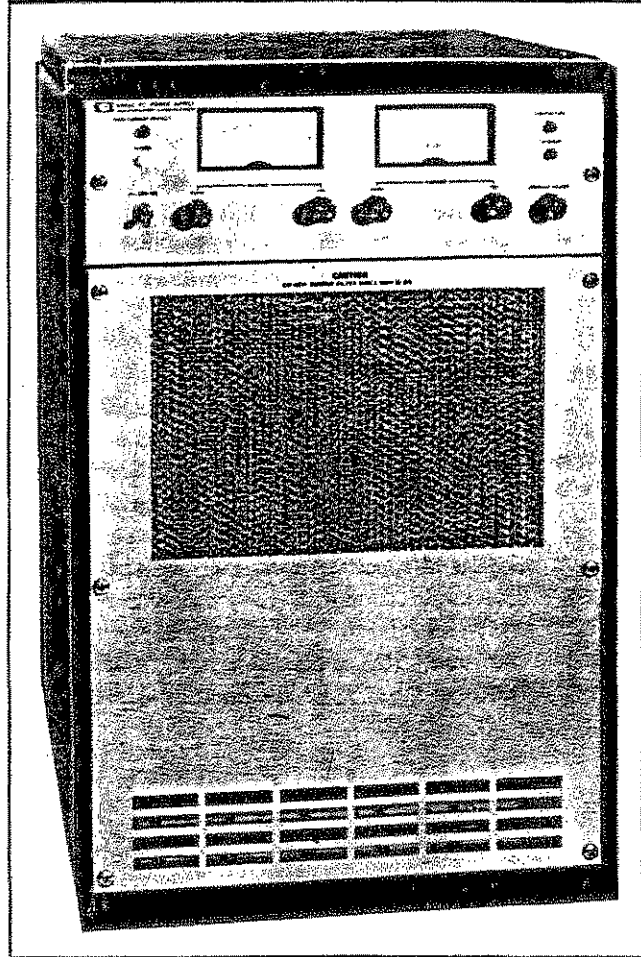

Figure 1-1. Typical 10kW Power Supply, SCR-10 Series

current capability is required. Auto-Parallel operation permits one-knob control of the total output current from a "master" supply.

e. *Battery Charging or Discharging.* The supply can be used in automatic battery charging or discharging applications. The automatic crossover between constant voltage and constant current permits the operation to be unattended.

1-5 SPECIFICATIONS

1-6 Detailed specifications for the power supply are given in Table 1-1 on Page 1-3.

1-7 OPTIONS

1-8 Options are customer-requested factory modifications of a standard instrument. The following options are available for the instrument covered by this manual. Where necessary, detailed coverage of the options is included throughout the manual. Notice that the customer must specify one of the five input power options available for this supply when ordering a unit. These options (001, 002, 003, 031, and 032), together with the other available options, are described below.

<u>Option No.</u>	<u>Description</u>
001	208Vac \pm 10%, 3-phase input, 57–63Hz.
002	230Vac \pm 10%, 3-phase input, 57–63Hz.
003	460Vac \pm 10%, 3-phase input, 57–63Hz.
005	50Hz ac input. Standard instrument is wired for nominal 60Hz ac input. Option 005 includes re-alignment, and in some cases, internal rewiring.
006	Internal overvoltage protection crowbar (<i>Not applicable to 6464C</i>). Protects delicate loads against power supply failure or operator error. Monitors the output voltage and places a virtual short circuit (conducting SCR) across load within 10 μ s after preset trip voltage is exceeded. For complete specifications, refer to Appendix A.
023	Rack kit for mounting one supply in standard 19" rack.
031	380Vac \pm 10%, 3-phase input, 57–63Hz.
032	400Vac \pm 10%, 3-phase input, 57–63Hz.

1-9 Accessories

1-10 One accessory, HP Part No. 14545A, is available with this supply. It consists of four snap-on casters and can be ordered with the power supply or separately from your local Hewlett-Packard sales office.

1-11 INSTRUMENT/MANUAL IDENTIFICATION

1-12 This power supply is identified by a three-part serial number tag. The first part is the power supply model number. The second part is the serial number prefix, which consists of a number-letter combination that denotes the date of a significant design change. The number designates the year, and the letter A through M designates the month, January through December, respectively, with "I" omitted. The third part is the power supply serial number; a different sequential number is assigned to each power supply.

1-13 If the serial number on your instrument does not agree with those on the title page of the manual, Change Sheets supplied with the manual or Manual Backdating Changes define the differences between your instrument and the instrument described by this manual.

1-14 ORDERING ADDITIONAL MANUALS

1-15 One manual is shipped with each power supply. Additional manuals may be purchased from your local Hewlett-Packard field office (see list at rear of this manual for addresses). Specify the model number, serial number prefix, and HP part number shown on the title page.

Table 1-1. Specifications

<p>INPUT: 208/230/380/400/460Vac \pm 10%, Three Phase, 57 to 63Hz, 50A per phase @ 230Vac.</p> <p>OUTPUT: 0-220V @ 0-50A. (NOTES 1 and 2.)</p> <p>LOAD REGULATION: <i>Constant Voltage</i> - Less than 0.05% plus 100mV for a load current change equal to the current rating of the supply. <i>Constant Current</i> - Less than 0.1% plus 50mA for a load voltage change equal to the voltage rating of the supply.</p> <p>LINE REGULATION: <i>Constant Voltage</i> - Less than 0.05% plus 100mV for any change within the input rating. <i>Constant Current</i> - Less than 0.1% plus 50mA for any change within the input rating.</p> <p>RIPPLE AND NOISE: <i>Constant Voltage</i> - Less than 330mVrms, 2V p-p (dc to 20MHz). (NOTE 2.)</p> <p>TEMPERATURE RATINGS: Operating: 0 to 50°C. Storage: -40 to +75°C.</p> <p>TEMPERATURE COEFFICIENT: <i>Constant Voltage</i> - Less than 0.03% plus 8mV change in output per degree Centigrade change in ambient following 30 minutes warm-up. <i>Constant Current</i> - Less than 0.06% plus 65mA change in output per degree Centigrade change in ambient following 30 minutes warm-up.</p> <p>STABILITY: <i>Constant Voltage</i> - Less than 0.15% plus 35mV total drift for 8 hours following 30 minutes warm-up under</p>	<p>constant ambient conditions. <i>Constant Current</i> - Less than 0.3% plus 250mA total drift for 8 hours following 30 minutes warm-up under constant ambient conditions.</p> <p>TRANSIENT RECOVERY TIME: Less than 50ms/100ms is required for output voltage recovery (in constant voltage operation) to within 5V/2V of the nominal output voltage following a load change from full load to half load or vice versa (NOTE 2).</p> <p>METERS: A front panel voltmeter (0-250V) and ammeter (0-60A) are provided. (Accuracy is 2% of full scale.)</p> <p>RESOLUTION: <i>Constant Voltage</i> - 44mV is the minimum output voltage change that can be obtained with the front panel controls. <i>Constant Current</i> - 50mA is the minimum output current change that can be obtained using the front panel controls.</p> <p>REMOTE RESISTANCE PROGRAMMING: <i>Constant Voltage</i> - 300 ohms/volt (Accuracy: 2%). All programming terminals are on a rear barrier strip. <i>Constant Current</i> - 20 ohms/ampere (Accuracy: 2%). All programming terminals are on a rear barrier strip.</p> <p>COOLING: Forced air cooling is employed by means of an internal fan.</p> <p>WEIGHT: 500 lbs. net. 555 lbs. shipping.</p> <p>SIZE: 16-3/4" W x 26-1/4" H x 26-1/8" D. The unit can be mounted in a standard 19" rack panel.</p>
---	--

NOTES:

- Specifications apply only when (a) supply is delivering more than 5% of maximum rated output voltage (CV operation) or 5% of maximum rated output current (CC operation), and (b) load is drawing more than 100W. Restriction (b) is lifted when supply is delivering more than 30% of maximum rated output voltage (CV operation) or 30% of maximum rated output current (CC operation).
- For operation with a 50Hz input (possible only with Option 05), output current is linearly derated from 100% at 40°C to 80% at 50°C. Other specifications (indicated in Table) must be increased by 50% for a 50Hz input.



POWER SUPPLIES

General Purpose: 300—11,000 W Output

Models 6434B—6483C

- Outstanding value—low cost/watt
- Up to 75% efficiency at full output
- Constant voltage/constant current operation

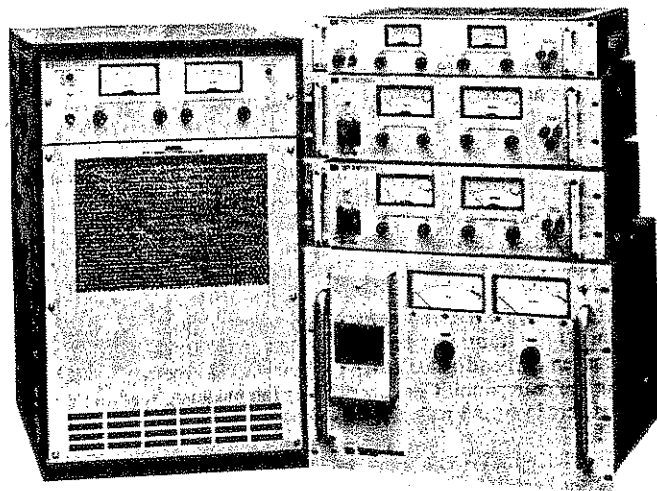

HP 6434B—6483C

Description

This series of SCR-regulated power supplies is designed for medium to high-power applications requiring a fixed or variable dc source with moderate regulation and ripple. For supplies with better regulation, faster response time, and lower ripple, see models HP 6259B—6274B on page 272.

Operating Features

All supplies in this series are of the constant voltage/constant current type. Large easy-to-read panel meters continuously monitor output voltage and current.

Input and output power, remote sensing, remote programming, and auto-series, -parallel, and -tracking connections are made to bus bars and terminal blocks on the rear panel.

Protective Features

In addition to the overload protection inherent in constant voltage/constant current operation, there are many other built-in protective features included in these supplies. The features vary within the three model classifications as follows:

HP 6434B—6448B: (1) Reverse voltage protection. (2) Fused ac input.

HP 6453A, 6456B, 6459A: (1) AC line loss protection circuit monitors 3-phase input and cuts off SCR's and opens output bus if a phase drops out; operation resumes when ac input returns to normal. (2) 3-phase input circuit breaker. (3) Optional internal crowbar (Option 006) protects load from overvoltage condition.

HP 6464C—6483C: (1) High-temperature protection thermostat opens input to power transformer and lights front panel indicator if supply overheats. (2) Prolonged overload protection circuit is activated and lights front panel indicator if output current exceeds approximately 115% of maximum rating. (3) Optional internal crowbar (except on HP 6464C) protects load from overvoltage condition. (4) Turn-on circuit limits peak line current during start-up into low impedance loads. (5) Phase-balance circuit permits operation with line-to-line input voltage imbalance up to 8%. (6) Overcurrent and over-voltage circuits of master slave supplies used in auto-series, -parallel, or -tracking operation can be interlocked.

Auto-Series, -Parallel, -Tracking Operation

Supplies may be connected in auto-series, or auto-tracking (except HP 6448B and 6483C, which cannot be connected in auto-series).

Up to three lower-power models (HP 6434B—6448B) may be connected in any of the above configurations. Higher-power model (HP 6453A/6483C) interconnection should ordinarily include no more than two supplies.

Remote Programming

The voltage and current outputs of the supplies can be programmed by a remote resistance, or for most models, a remote voltage source. Programming speeds and coefficients are detailed in the specifications table.

AC Power Requirements

The ac power requirements vary with the three model classifications (see option listings). When powered from a 50 Hz source (possible with option 005), the rms ripple and transient response specifications increase by 50%. The p-p ripple specification is unchanged by line frequency.

Specifications†

RATINGS			PERFORMANCE						
DC Output		HP Model	Load Effect		Source Effect		PARD Δ rms/p-p	Temperature Coefficient	Drift
Volts‡	Amperes‡		Voltage	Current	Voltage	Current			
0-8	0-1000	6464C	0.05% + 5 mV	0.1% + 1 A	0.05% + 5 mV	0.1% + 1 A	80 mV/1 V	0.03% + 100 μV	0.03% + 1 mV
0-15	0-200	6453A	0.2% + 10 mV††	1% or 2 A††	0.2% + 10 mV††	1% or 2 A††	150 mV rms	0.05% + 2 mV	0.25% + 10 mV
0-15 or 18	0-600 or 500*	6466C	0.05% + 5 mV	0.1% + 0.6 A	0.05% + 5 mV	0.1% + 0.6 A	180 mV/1 V	0.03% + 200 μV	0.2% + 1 mV
0-36	0-100	6456B	0.2% + 10 mV††	1% or 1 A††	0.2% + 10 mV††	1% or 1 A††	180 mV rms	0.05% + 2 mV	0.25% + 10 mV
0-36	0-300	6469C	0.05% + 5 mV	0.1% + 0.3 A	0.05% + 5 mV	0.1% + 0.3 A	180 mV/1 V	0.03% + 400 μV	0.15% + 1 mV
0-40	0-25	6434B	40 mV	200 mA	18 mV	200 mA	40 mV/500 mV	0.03% + 5 mV	0.1% + 20 mV
0-64	0-50	6459A	0.2% + 10 mV††	1% or 0.5 A††	0.2% + 10 mV††	1% or 0.5 A††	160 mV rms	0.05% + 2 mV	0.25% + 10 mV
0-64	0-150	6472C	0.05% + 100 mV	0.1% + 0.15 A	0.05% + 100 mV	0.1% + 0.15 A	160 mV/2 V	0.03% + 4 mV	0.15% + 16 mV
0-110	0-100	6475C	0.05% + 100 mV	0.1% + 0.1 A	0.05% + 100 mV	0.1% + 0.1 A	200 mV/2 V	0.03% + 5 mV	0.15% + 20 mV
0-120	0-2.5	6443B	120 mV	25 mA	60 mV	25 mA	240 mV/400 mV	0.03% + 20 mV	0.1% + 60 mV
0-220	0-50	6477C	0.05% + 100 mV	0.1% + 50 mA	0.05% + 100 mV	0.1% + 50 mA	300 mV/2 V	0.03% + 6 mV	0.15% + 35 mV
0-300	0-35	6479C	0.05% + 100 mV	0.1% + 35 mA	0.05% + 100 mV	0.1% + 35 mA	330 mV/3 V	0.03% + 11 mV	0.15% + 45 mV
0-440, 500 or 600	0-25, 20, 15*	6483C	0.05% + 100 mV	0.1% + 35 mA	0.05% + 100 mV	0.1% + 35 mA	600 mV/5 V	0.03% + 20 mV	0.15% + 80 mV
1-600	5 mA-1.5 A	6448B	1 V	40 mA	600 mV	15 mA	600 mV/2 V	0.03% + 100 mV	0.1% + 300 mV

† Refer to page 264 for complete specification definitions.

†† Specified for combined line and load regulation.

Δ For operation with a 50 Hz input (possible only with Option 005), the rms ripple and transient response specifications are increased by 50%.

* The output current rating is given in the same order corresponding with the voltage rating.

§ Under light loading conditions, power supply may not meet all published specifications. The graph on the next page defines the permissible operating regions for CV and CC modes of operation.

For operation with a 50 Hz input (possible only with Option 005), output current is linearly derated from 100% at 40°C to 80% at 50°C.

POWER SUPPLY OUTPUT RESTRICTIONS AS A FUNCTION OF LOADING

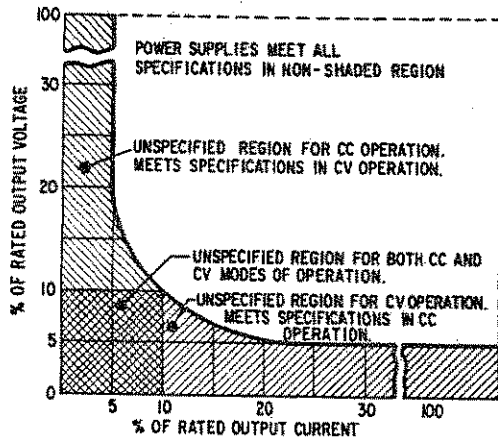

An ac input option must be specified when ordering.

Line Cords

Line cords are not supplied with models 6453A-6483C.

Size

- Model 6443B:** 89 H x 483 W x 445 mm D (3.5" x 19" x 17.5").
- Models 6434B, & 6448B:** 133 H x 483 W x 432 mm D (5.25" x 19" x 17").
- Models 6453A, 6456B, & 6459A:** 356 H x 483 W x 500 mm D (14" x 19" x 19.7").
- Models 6464C, 6466C, 6469C, 6472C, 6475C, 6477C, 6479C, & 6483C:** 705 H x 483 W x 715 mm D (27.75" x 19" x 28.12").

Option Descriptions

HP 6434B-6448B

- Std:** 115 V ac, ± 10%, single phase, 57-63 Hz
- 005:** realignment for 50 Hz operation
- 010:** chassis slides
- 027:** 208 V ac, ± 10%, single phase, 57-63 Hz
- 028:** 230 V ac, ± 10%, single phase, 57-63 Hz
- 910:** one extra operating and service manual shipped with each power supply

HP 6453A, 6456B, 6459A

- An ac input option must be specified when ordering. AC input connections are by means of a 4-conductor connector at rear of unit. A matching Hubbell No. 7413G plug (HP part number 1251-1570) is furnished.
- 001:** 208 V ac, ± 10%, 3-phase, 15.5 A/phase, 57-63 Hz
- 002:** 230 V ac, ± 10%, 3-phase, 14 A/phase, 57-63 Hz
- 003:** 460 V ac, ± 10%, 3-phase, 7 A/phase, 57-63 Hz
- 005:** realignment for 50 Hz operation
- 006:** overvoltage protection crowbar
- HP 6453A, 6459A**
- HP 6456B**
- 010:** chassis slides
- 031:** 380 V ac, ± 10%, 3-phase, 8.5 A/phase, 57-63 Hz
- 032:** 400 V ac, ± 10%, 3-phase- 8.0 A/phase, 57-63 Hz
- 910:** one extra operating and service manual shipped with each power supply.

HP 6464C-6483C

- An ac input option must be specified when ordering. AC input connections are by means of enclosed 4-wire terminal block
- 001:** 208 V ac, ± 10%, 3-phase, 55 A/phase, 57-63 Hz
- 002:** 230 V ac, ± 10%, 3-phase, 50 A/phase, 57-63 Hz
- 003:** 460 V ac, ± 10%, 3-phase, 25 A/phase, 57-63 Hz
- 005:** realignment for 50 Hz operation
- 006:** internal overvoltage protection crowbar
- HP 6477C, 6479C, 6483C**
- HP 6466C**
- HP 6469C**
- HP 6472C, 6475C**
- 023:** rack mounting attachments for standard 19" rack
- 031:** 380 V ac, ± 10%, 3-phase, 30 A/phase, 57-63 Hz
- 032:** 400 V ac, ± 10%, 3-phase, 28.5 A/phase, 57-63 Hz
- 040:** prepares power supply to be programmed with resistance by an HP 6940B or 6942A.
- 910:** one extra operating and service manual shipped with each power supply.

Accessory

- 14545A:** casters for HP 6464C-6483C—set of four

Specifications, continued

Resolution		REMOTE CONTROL										GENERAL		Options
		Load Transient Recovery ^Δ	Resistance Coefficient		Voltage Coefficient†		Up		Down		Net Weight			
			V	C	Voltage	Current	Voltage	Current	NL	FL	NL	FL	Kg	
65 mV	1 A	100 ms, 150 mV	200 Ω/V ±2%	1 Ω/A	0.4 V/V	30 mV/A	1 s	0.5 s	20 s	0.2 s	226	500	1, 2, 3, 5, 6, 23, 31, 32, 40	
18 mV	0.5 A	100 ms, 500 mV	200 Ω/V ±2%	5 Ω/A	1 V/V	60 mV/A	1 s	0.5 s	15 s	0.2 s	226	500	1, 2, 3, 5, 6, 23, 31, 32, 40	
90 mV	0.5 A	50 ms, 300 mV	200 Ω/V ±2%	2 Ω/A	166 mV/V	60 mV/A	1 s	0.5 s	60 s	0.5 s	108	238	1, 2, 3, 5, 6, 10, 31, 32	
10 mV	12.5 mA	200 ms, 200 mV	200 Ω/V ±2%	12 Ω/A	1 V/V	**	0.3 s	1.2 s	75 s	1.2 s	30.4	67	5, 10, 27, 28	
64 mV	0.15 mA	100 ms, 750 mV	300 Ω/V ±2%	6.7 Ω/A ±2%	1 V/V ±3%	41.2 mV/A ±7%	1.4 s	2.5 s	55 s	0.7 s	226	500	1, 2, 3, 5, 6, 23, 31, 32, 40	
22 mV	0.3 mA	100 ms, 500 mV	300 Ω/V ±2%	10 Ω/A	1 V/V	60 mV/A	1 s	0.5 s	80 s	0.7 s	226	500	1, 2, 3, 5, 6, 23, 31, 32	
30 mV	1.3 mA	200 ms, 600 mV	300 Ω/V ±2%	120 Ω/A	1 V/V	**	0.5 s	2 s	210 s	2 s	14	31	5, 10, 27, 28	
44 mV	50 mA	100 ms, 2 V	300 Ω/V ±2%	20 Ω/A	1 V/V	**	0.5 s	2 s	95 s	1 s	226	500	1, 2, 3, 5, 6, 23, 31, 32	
60 mV	35 mA	100 ms, 3 V	300 Ω/V ±2%	28.6 Ω/A ±2%	1 V/V ±3%	177 mV/A ±7%	1.5 s	2 s	75 s	1.6 s	226	500	1, 2, 3, 5, 6, 23, 31, 32	
60 mV	25 mA	100 ms, 5 V	300 Ω/V ±2%	40 Ω/A ±2%	1 V/V ±3%	0.25 V/A ±2%	1.5 s	2 s	120 s	2 s	226	500	1, 2, 3, 5, 6, 23, 31, 32	
60 mV	0.75 mA	200 ms, 3 V	300 Ω/V ±2%	600 Ω/A	1 V/V	**	0.2 s	1 s	45 s	2 s	27.6	61	5, 10, 27, 28	

^ΔFor operation with a 50 Hz input (possible only with Option 005), the rms ripple and transient response specifications are increased by 50%.

**This feature is not available.

†An ac input option must be specified when ordering these 3-phase models.

‡Special Option J30 must be ordered with models 6434B-6448B and 6466C-6483C to be programmed with an HP 69501B Power Supply Programmer. Contact your local HP Field Engineer for ordering instructions.

SECTION II INSTALLATION

2-1 INITIAL INSPECTION

2-2 Before shipment, this instrument was inspected and found to be free of mechanical and electrical defects. As soon as the instrument is unpacked, inspect for any damage that may have occurred in transit. Save all packing materials until the inspection is completed. If damage is found, file a claim with the carrier immediately. Hewlett-Packard Sales and Service office should be notified.

2-3 Mechanical Check

2-4 This check should confirm that there are no broken knobs or connectors, that the cabinet and panel surfaces are free of dents and scratches, and that the meters are not scratched or cracked.

2-5 Electrical Check

2-6 The instrument should be checked against its electrical specifications. Section V includes an "in-cabinet"

performance check to verify proper instrument operation.

2-7 INSTALLATION DATA

2-8 The instrument is shipped ready for operation. It is necessary only to connect the instrument to a source of power and it is ready for operation.

2-9 Location

2-10 This instrument is fan cooled. Sufficient space should be allotted so that a free flow of cooling air can reach the sides of the instrument when it is in operation. It should be used in an area where the ambient temperature does not exceed 50°C.

2-11 Outline Diagram

2-12 Figure 2-1 illustrates the two basic outline shapes for power supplies of the SCR-10 Series.

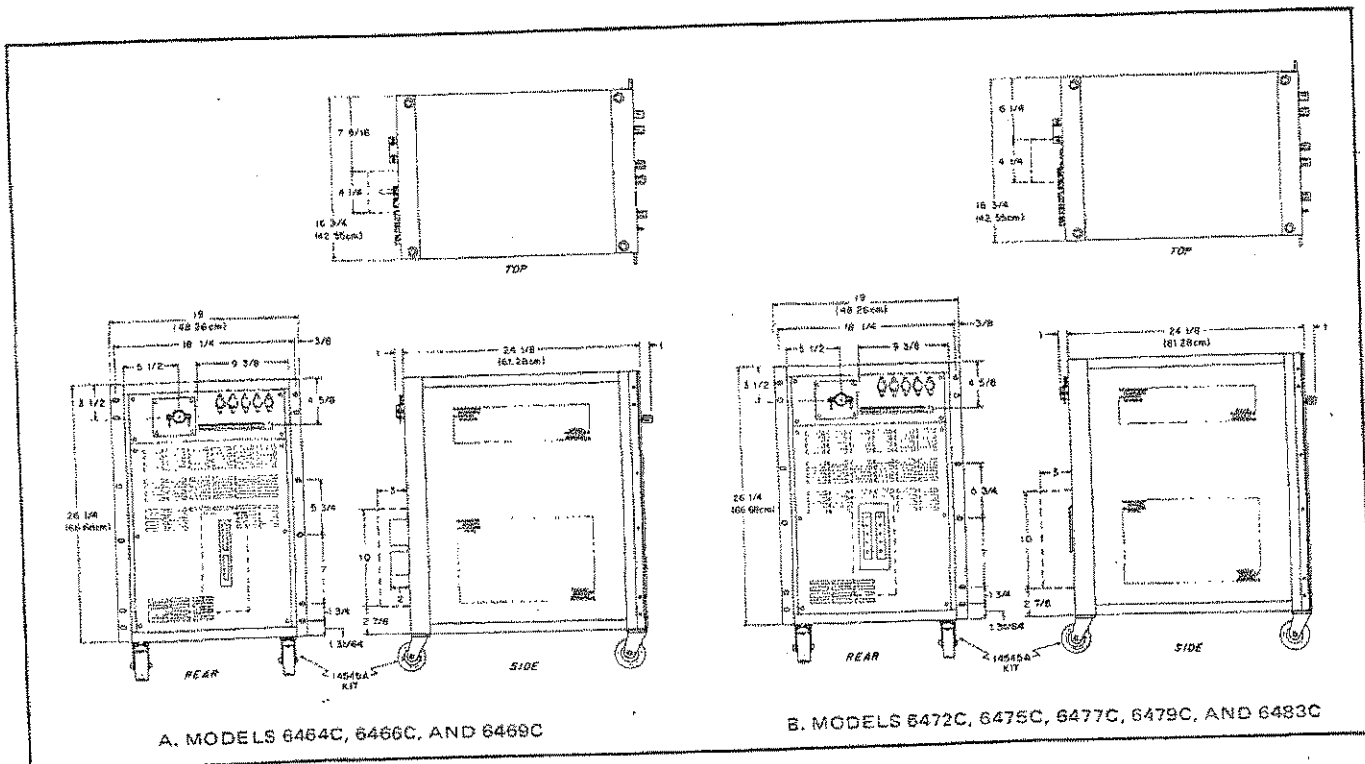

Figure 2-1. Outline Diagram

2-13 Rack Mounting

2-14 To rack mount the unit, Option 023 is installed at the factory. The user receives the supply with rack ears attached to the side-front of the unit. The supply can then be mounted in a standard 19-inch rack using standard mounting screws.

2-15 INPUT POWER REQUIREMENTS

2-16 The input power is specified by the buyer in his original purchase contract using the appropriate option number. Five input options are available; Option 001 (208Vac), 002 (230Vac), 003 (460Vac), 031 (380Vac) and 032 (400Vac). All of the optional line voltages may vary within $\pm 10\%$.

2-17 All ac input connections are made at the rear terminal block (a power cord and connector are not supplied with the unit). The user should ensure that the ac input wires are of the proper gauge. For example, the line current is 50 amperes (maximum) for a 230Vac input, dictating that each conductor be at least number 8 gauge wire. The safety ground wire should be the same gauge as the ac input wires to ensure that it does not open and create a safety hazard.

2-18 The ac power source to this supply may be either delta or wye with isolated neutral. The three phase input voltages must be balanced to within 8% of each other for the supply to operate. However, if the input line voltages are unbalanced by more than 3%, the unit may not meet the published ripple and noise specification; although it will meet all other specifications. Moreover, if the user's line imbalance exceeds 3%, it is advisable to check the input line currents and adjust the current balance circuit, if necessary (refer to Paragraph 5-95).

2-19 Any SCR regulated supply, because of its inherent characteristics, cannot tolerate a great degree of distortion in the input line voltage. The amount of distortion that can be tolerated is not precisely defined, but the supply should never be driven from the output of an inverter or a saturable-reactor type of regulator where the nominally sinusoidal waveshape is flattened considerably. Another cause of distortion is high line impedance. The user should contact the factory if trouble is experienced in this area.

2-20 208/230Vac Conversion

2-21 To convert the unit from a 208Vac (Option 001) to a 230Vac (Option 002) input, or vice versa, it is necessary only to restrap transformers T4, T5, and A3T1, T2, and T3. No other changes are necessary because the components used for Options 001 and 002 are identical. The schematic diagram, Figure 7-7, shows the transformers noted above

strapped for 230Vac operation. Hence, to convert the unit from a 208Vac input to a 230Vac input, remove the 208V ac jumpers and connect the transformers as shown on the schematic. To convert the unit from a 230Vac input to a 208Vac input, simply use the 208V terminals as follows:

a. With the unit off, remove jumper between T5-3 and T5-6. Connect new jumper between T5-2 and T5-5. Disconnect wire from fuse F8 to T5-6 and connect it between F8 and T5-5.

b. For transformer T4, remove three straps between A1-230, B1-230, and C1-230 and connect a strap between A1-208, B1-208, and C1-208.

c. On transformers A3T1, A3T2, and A3T3, disconnect three jumpers between T1-0V and T2-230, T2-0V and T3-230, and T3-0V and T1-230. Connect three jumpers as follows: T1-0V to T2-208, T2-0V to T3-208, and T3-0V to T1-208.

2-22 380/400Vac Conversion

2-23 To convert the unit from a 380Vac (Option 031) to a 400Vac (Option 032) input, or vice versa, it is necessary only to restrap transformers T4, T5, and A3T1, T2, and T3. No other changes are necessary because the components used for Options 031 and 032 are identical.

2-24 **Transformer Connections for 380Vac Input.** For a 380Vac input, the 0V tap on the primary transformer T5 is connected to fuse F7 and the 380V tap is connected to fuse F8. The 400V tap is open. The secondary windings are connected as shown on the schematic, Figure 7-7.

2-25 Transformer T4 is connected in the delta-star configuration shown on Figure 7-7. For 380Vac operation, connect tap A1 to tap 380 on the B section, tap B1 to tap 380 of the C section, and tap C1 to tap 380 of the A section. The three 400V taps are open.

2-26 Transformers A3T1, A3T2 and A3T3 are connected in the delta-delta configuration shown on Figure 7-7. For 380Vac operation, connect T1-0V to T2-380V, T2-0V to T3-380 and T3-0V to T1-380V. The 400 taps on the three transformers are open.

2-27 **Transformer Connections for 400Vac Input.** For a 400Vac input, the 0V tap on the primary of T5 must be connected to fuse F7 and the 400V tap must be connected to fuse F8. The 380V tap is left open. Secondary taps remain connected as shown on Figure 7-7.

2-28 For transformer T4 (delta-star configuration) tap A1 is connected to tap 400 on the B section, tap B1 is connected to tap 400 on the C section, and tap C1 to tap 400 on the A section. The three 380V taps are left open.

2-29 Transformers A3T1, A3T2, and A3T3 are connected in an delta-delta configuration as follows: T1-0V to T2-400V, T2-0V to T3-400V and T3-0V to T1-400V. The 380V taps on the three transformers are left open.

2-30 50Hz Ac Input (Option 005)

2-31 For operation from a 50Hz source it is necessary only to readjust the output ripple as described in Paragraph 5-94. In rare instances it may be necessary to readjust the transient recovery potentiometer (A1R48) if the supply shows signs of oscillating.

2-32 REPACKAGING FOR SHIPMENT

2-33 To insure safe shipment of the instrument, it is recommended that the package designed for the instrument be used. The original packaging material is reusable. If it is not available, contact your local Hewlett-Packard field office to obtain the materials. This office will also furnish the address of the nearest service center to which the instrument can be shipped. Be sure to attach a tag to the instrument specifying the owner, model number, full serial number, and service required, or a brief description of the trouble.

SECTION III OPERATING INSTRUCTIONS

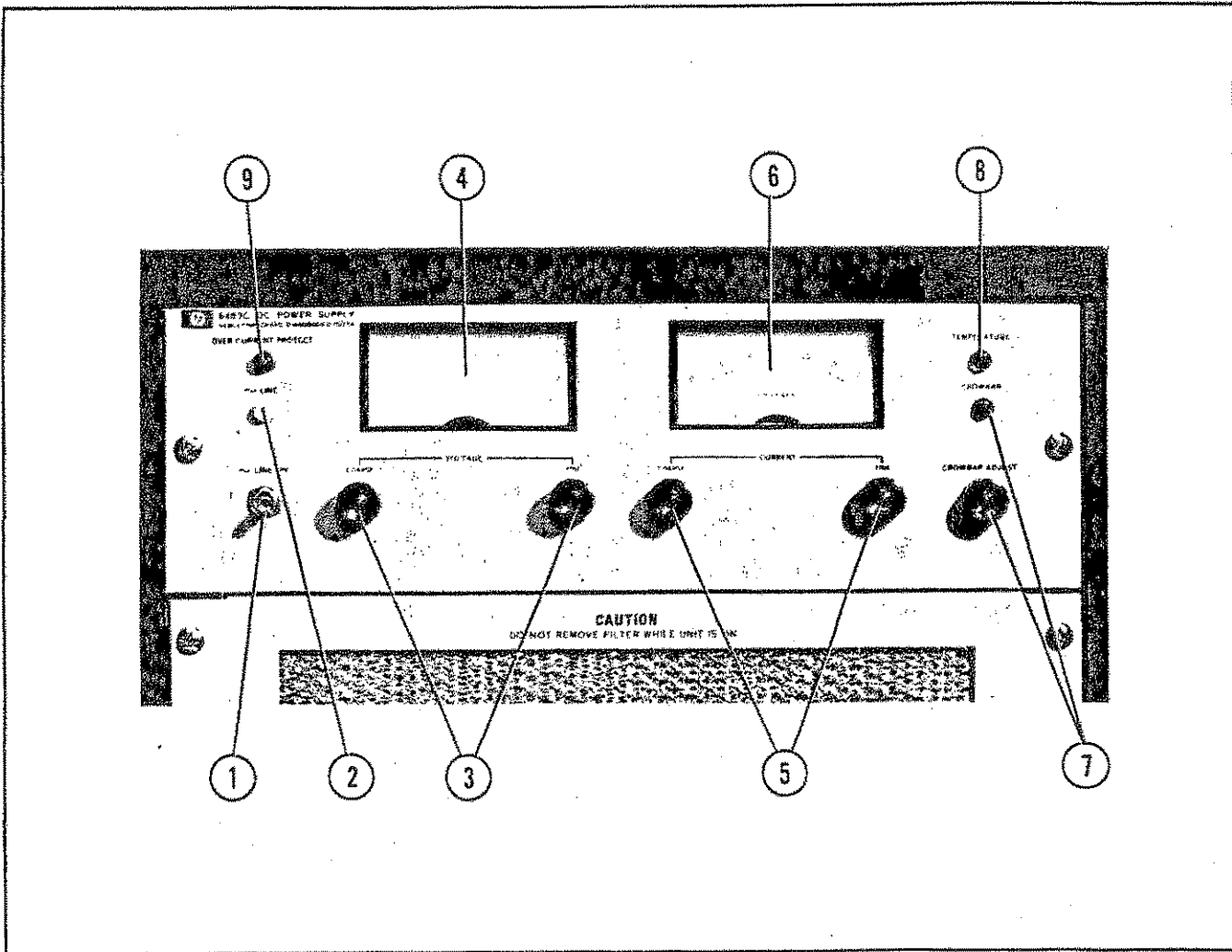

Figure 3-1. Front Panel Controls and Indicators, Typical SCR-10 Supply

3-1 TURN-ON CHECKOUT PROCEDURE

3-2 The following checkout procedure describes the use of the front panel controls and indicators (Figure 3-1) and ensures that the supply is operational.

a. Set \sim LINE ON switch (1) to on and observe that pilot lamp (2) lights.

b. After turn-on delay period (see NOTE), rotate CURRENT controls fully clockwise and adjust VOLTAGE controls (3) to obtain desired output voltage on voltmeter (4)

NOTE

The supply output is held off for approximately 10 to 20 seconds after turn-on by an internal control circuit.

c. To check out constant current circuit, first *turn off supply*. Then, short circuit output bus bars and rotate VOLTAGE controls fully clockwise. Turn-on supply.

d. After turn-on delay, adjust CURRENT controls (5)

until desired output current is indicated on ammeter (6).

e. If supply is equipped with an overvoltage crowbar (Option 006), front panel will contain CROWBAR ADJUST pot and lamp (7). If Option 006 is not ordered this portion of panel is blank. Refer to Appendix A for crowbar operating instructions.

f. TEMPERATURE and OVERCURRENT PROTECT lamps, (8) and (9), are described in Paragraph 3-24. Before connecting actual load to supply, read the following paragraphs.

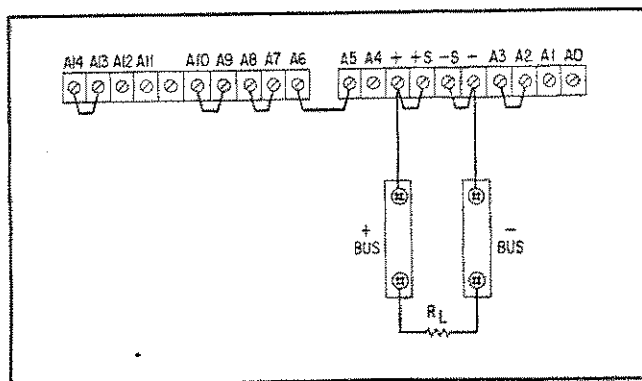

Figure 3-2. Normal Strapping Pattern

3-3 OPERATING MODES

3-4 The power supply is designed so that its mode of operation can be selected by making strapping connections between particular terminals on the terminal strips at the rear of the power supply. The terminal designations are plated on the P.C. board below their respective terminals. The following paragraphs describe the procedures for utilizing the various operational capabilities of the power supply. A more theoretical description concerning the operational features of this supply is contained in Application Note 90A, Power Supply Handbook (available at no charge from your local Hewlett-Packard sales office). Sales office addresses appear at the rear of the manual.

3-5 NORMAL OPERATING MODE

3-6 The power supply is normally shipped with its rear terminal strapping connections arranged for constant voltage/constant current, local sensing, local programming, single unit mode of operation. This strapping pattern is shown in Figure 3-2. The operator selects either a constant voltage or a constant current output using the front panel controls (local programming; no strapping changes are necessary).

3-7 Constant Voltage

3-8 To select a constant voltage output, proceed as follows:

- Turn on power supply and adjust VOLTAGE controls for desired output voltage with output terminals open.
- Short circuit output terminals and adjust CURRENT controls for maximum output current allowable (current limit), as determined by load conditions. If a load change causes the current limit to be exceeded, the power supply will automatically cross over to constant current output at the preset current limit and the output voltage will drop proportionately. In setting the current limit, allowance must be made for high peak currents which can cause unwanted crossover. (Refer to Paragraph 3-63.)

3-9 Constant Current

3-10 To select a constant current output, proceed as follows:

- Short circuit output terminals and adjust CURRENT controls for desired output current.
- Open output terminals and adjust VOLTAGE controls for maximum output voltage allowable (voltage limit), as determined by load conditions. If a load change causes the voltage limit to be exceeded, the power supply will automatically cross over to constant voltage output at the preset voltage limit and the output current will drop proportionately. In setting the voltage limit, allowance must be made for high peak voltages which can cause unwanted crossover. (Refer to Paragraph 3-63.)

NOTE

As indicated on the Specification Table (1-1) the supply may not meet all specifications under "light load" conditions. These constraints are due to minimum operating thresholds inherent in the SCR's in the regulator. However, as shown on Table 1-1, the supply will operate satisfactorily if the supply delivers more than 30% of the rated output voltage (Constant Voltage operation) or rated output current (Constant Current operation). Only 5% of rated output voltage or current is required provided that the supply is delivering more than 100 Watts to the load.

3-11 No Load Operation

3-12 When the supply is operated without a load, down-programming speed is considerably slower than in normal loaded operation. The actual time required for the output voltage to decrease to a level set by the front panel control varies from approximately 6 seconds to about 200 seconds, depending on the model number and the incremental change.

3-13 Output Ranges — Models 6466C and 6483C Only

3-14 Model 6466C can be operated in one of two output ranges while Model 6483C has three output ranges (refer to Specification Table, 1-1, for these units). No range switching is required but the current and voltage requirements of the load should be predetermined to ensure that the ratings for a particular range will not be exceeded. If a rating is exceeded, one of the supply's internal protection circuits will be activated. For example, if the supply is operating in the high voltage, low current range and the output current exceeds the rating for that range, the overcurrent circuit will become activated and shut off the supply.

3-15 Connecting Load

3-16 Each load should be connected to the power supply output terminals using separate pairs of connecting wires. This will minimize mutual coupling effects between loads and will retain full advantage of the low output impedance of the power supply. Each pair of connecting wires should be as short as possible and twisted or shielded to reduce noise pickup. (If a shielded pair is used, connect one end of the shield to ground at the power supply and leave the other end unconnected.)

3-17 If load considerations require that the output power distribution terminals be remotely located from the power supply, then the power supply output terminals should be connected to the remote distribution terminals via a pair of twisted or shielded wires and each load should be separately connected to the remote distribution terminals. For this case, remote sensing should be used. (Refer to Paragraph 3-40.)

3-18 Grounding

3-19 Positive or negative output voltages can be obtained from the supply by grounding either output bus. If the output is floated (neither output bus grounded) it can be operated up to 100Vdc above ground (300Vdc above ground for Models 6475C, 6477C, and 6479C).

3-20 When grounding the output, the customer's ground must be used and connected to the desired output bus on the supply. *Do not ground the output at the supply's chassis or at the ac ground terminal on the rear of the supply.* These points are at safety ground and are not the neutral of the power source (refer to Section II). By following these recommendations and running a separate lead from each output bus to the load, the user will be doubly certain that no load current will flow through the ac input wires to the supply.

3-21 Operation Beyond Rated Output

3-22 The shaded area on the front panel meter face indicates the approximate amount of output voltage or current that may be available in excess of the normal rated output. Although the supply can be operated in this shaded region without being damaged, it cannot be guaranteed to meet all of its performance specifications.

3-23 Protection Circuits

3-24 This supply contains an internal overload protection circuit which shuts off the supply in the event of a prolonged overcurrent or overtemperature condition (details given in Section IV). This circuit also illuminates the applicable indicator lamp (OVERCURRENT PROTECT or TEMPERATURE) on the front panel. If one of these lamps should light, the operator should set the LINE switch to off and turn the VOLTAGE and CURRENT controls to zero (CCW). Next, the unit should be turned back on. If the overload lamp lights again, turn the unit off and proceed to Section V, Troubleshooting. If the lamp does not light, the overload may have been caused by a line transient or an improper connection at the rear barrier strip. Ensure that all screws on the rear barrier strip are tight and that the strapping pattern agrees with the desired operation.

3-25 OPTIONAL OPERATING MODES

3-26 Remote Programming, Constant Voltage

3-27 The constant voltage output of the power supply can be programmed (controlled) from a remote location if required. Either a resistance or voltage source can be used as the programming device. The wires connecting the programming terminals of the supply to the remote programming device should be twisted or shielded to reduce noise pickup. The VOLTAGE controls on the front panel are automatically disabled by the following procedures.

3-28 Resistance Programming (Figure 3-3). In this mode,

the output voltage will vary at a rate determined by the constant voltage programming coefficient (refer to Specifications Table, 1-1). The programming coefficient is determined by the programming current. This current is factory adjusted to within 1%. If greater programming accuracy is required, it may be achieved by adjusting A1R9 as discussed in Paragraph 5-76.

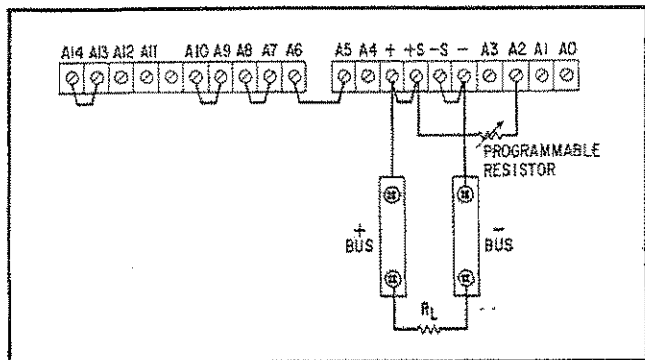

Figure 3-3. Remote Resistance Programming, Constant Voltage

3-29 The output voltage of the supply should be $0 \pm 10\text{mV}$ when zero ohms is connected across the programming terminals. If a zero ohm voltage closer to zero than this is required, it may be achieved by inserting and adjusting A1R11 as discussed in Paragraph 5-75.

3-30 To maintain the stability and temperature coefficient of the power supply, use programming resistors that have stable, low noise, and low temperature coefficient (less than 30ppm per degree Centigrade) characteristics. A switch can be used in conjunction with various resistance values in order to obtain discrete output voltages. The switch should have make-before-break contacts to avoid momentarily opening the programming terminals during the switching interval.

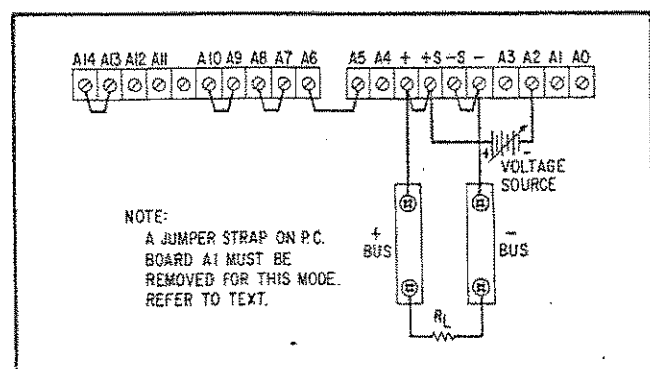

Figure 3-4. Remote Resistance Programming, Constant Voltage, Unity Gain

3-31 Voltage Programming, Unity Gain (Figure 3-4). Employ the strapping pattern shown in Figure 3-4 for voltage programming with unity gain. In this mode, the output voltage will vary in a 1 to 1 ratio with the programming voltage (reference voltage) and the load on the programming voltage source will not exceed 20 microamperes.

3-32 To prevent the internal programming current from flowing to terminal A2 and into the external voltage source, a jumper strap on P.C. Board A1 must be removed (see Figure 7-1 for location of the jumper). Be sure to reconnect this jumper before converting the unit to a different operating mode.

3-33 The output voltage of this supply *cannot* be voltage programmed with gain unlike some of the other HP supplies.

3-34 Remote Programming, Constant Current

3-35 Either a resistance or a voltage source can be used to control the constant current output of the supply. The CURRENT controls on the front panel are automatically disabled by the following procedures.

3-36 Resistance Programming (Figure 3-5). In this mode, the output current varies at a rate determined by the constant current programming coefficient given in Specifications Table, 1-1. The programming coefficient is determined by the constant current programming current which is adjusted to within 2% at the factory. If greater programming accuracy is required, it may be achieved by adjusting A1R25 as discussed in Paragraph 5-83. The output current of the supply when zero ohms is placed across the programming terminals may be set to exactly zero by adjusting A1R28 as discussed in Paragraph 5-82.

3-37 Use stable, low noise, low temperature coefficient (less than 30ppm/°C) programming resistors to maintain the power supply temperature coefficient and stability

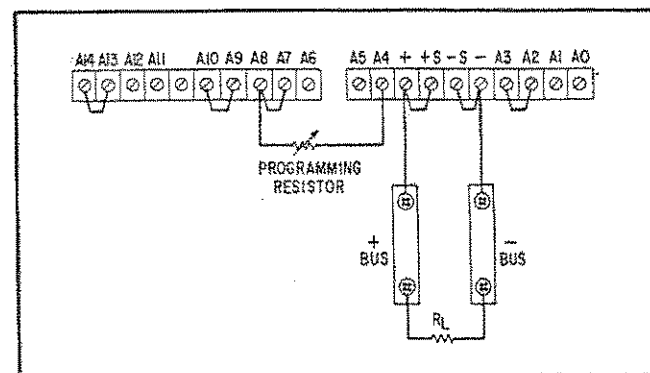

Figure 3-5. Remote Resistance Programming, Constant Current

specifications. A switch may be used to set discrete values of output current. A make-before-break type of switch should be used since the output current will exceed the maximum rating of the power supply if the switch contacts open during the switching interval.

CAUTION

If the programming terminals (A4 and A8) should open at any time during the remote resistance programming mode, the output current will rise to a value that may damage the load. If, in the particular programming configuration in use, there is a chance that the terminals might become open, it is suggested that a 1kΩ resistor be connected across the programming terminals. Like the programming resistor, this resistor should be a low noise, low temperature coefficient type. Note that when this resistor is used, the resistance value actually programming the supply is the parallel combination of the remote programming resistance and the resistor across the programming terminals.

3-38 Voltage Programming With Gain (Figure 3-6). The power supply output current can be programmed using an external voltage source with variable gain by utilizing the strapping pattern shown in Figure 3-6. In this mode, the output current will vary linearly from 0 to maximum rating when the voltage source is programmed from 0 to 6.2 volts. The value of the voltage source appearing across terminals A9 and A10 should not exceed 7.4Vdc if possible damage to the instrument is to be avoided.

3-39 External resistor R_p should have stable, low noise, and low temperature coefficient (less than 30ppm per degree Centigrade) characteristics in order to maintain the stability and temperature specifications of the power supply.

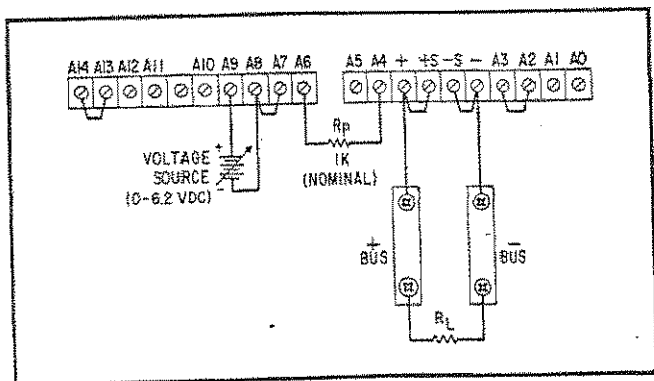

Figure 3-6. Remote Voltage Programming, Non-Unity Gain, Constant Current

Note that it is possible to use the front panel current controls already in the supply (R_3 and R_4) as the gain control (R_p) by simply removing the external R_p and strapping terminals A5 and A6 together.

3-40 Remote Sensing (Figure 3-7)

3-41 Remote sensing is used to maintain good regulation at the load and reduce the degradation of regulation which would occur due to the voltage drop in the leads between the power supply and the load. Remote sensing is accomplished by utilizing the strapping pattern shown in Figure 3-7. The power supply should be turned off before changing strapping patterns. The leads from the sensing ($\pm S$) terminals to the load will carry much less current than the load leads and it is not required that these leads be as heavy as the load leads. However, they must be twisted or shielded to minimize noise pickup.

3-42 For reasonable load lead lengths, remote sensing greatly improves the performance of the supply. However, if the load is located a considerable distance from the supply, added precautions must be observed to obtain satisfactory operation. Notice that the voltage drop in the load leads subtracts directly from the available output voltage and also reduces the amplitude of the feedback error signals that are developed within the unit. Because of these factors it is recommended that the drop in the negative load lead not exceed 3 volts. If a larger drop must be tolerated, please consult an HP Sales Engineer.

NOTE

Due to the voltage drop in the load leads, it may be necessary to readjust the current limit in the remote sensing mode.

3-43 Observance of the precautions in Paragraph 3-42 will result in a low dc output impedance at the load. However,

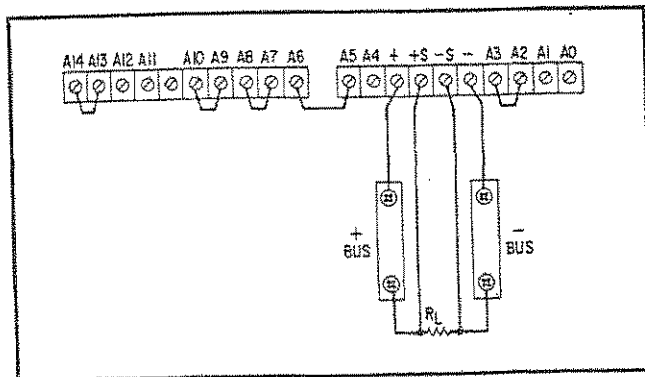

Figure 3-7. Remote Sensing

another factor that must be considered is the inductance of long load leads. This causes a high ac impedance and could affect the stability of the feedback loop seriously enough to cause oscillation. If this is the case, it is recommended that the following actions be taken:

- a. Adjust equalization control A1R48 to remove oscillation, or to achieve best possible transient response for given long load lead configuration. Refer to Paragraph 5-88 for discussion of transient response measurement.
- b. If performing adjustment in step (a) above does not remove oscillation, connect a capacitor having similar characteristics to those of the output capacitors (C1, C2, etc.) used in the supply, directly across load using short leads. Readjust equalization control R48 as in step (a) above after making this change.

3-44 Although the strapping patterns shown in Figures 3-3 through 3-6 employ local sensing, it is possible to operate a power supply simultaneously in the remote sensing and remote programming modes.

3-45 Auto-Parallel Operation (Figure 3-8)

3-46 Two (maximum) SCR-10 power supplies can be connected in an Auto-Parallel arrangement to obtain an output current greater than that available from one supply. Auto-Parallel operation permits equal current sharing under all load conditions, and allows complete control of the output current from the master power supply.

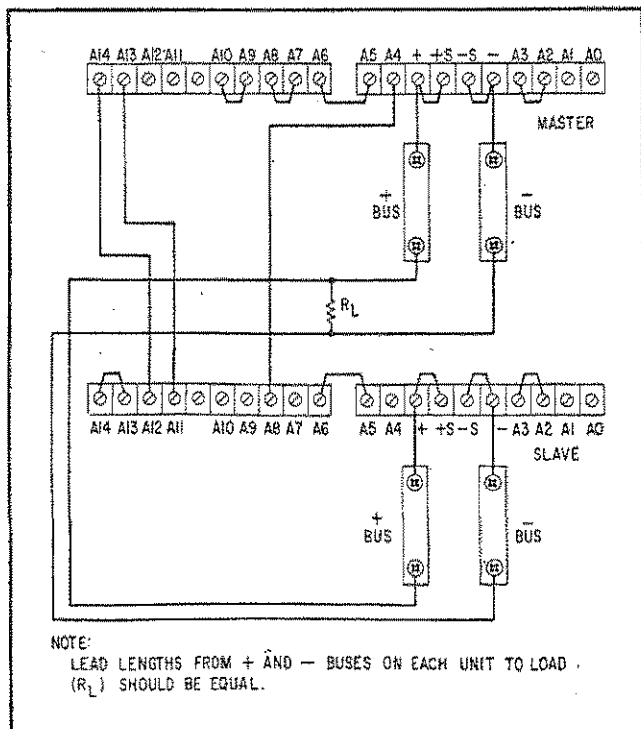

Figure 3-8. Auto-Parallel Operation

of the slave will be approximately equal to the master's output current regardless of the load conditions. Because the output current controls of the slave are operative, they should be set to maximum to prevent the slave reverting to constant current operation; this would occur if the master output current setting exceeded the slave's.

3-47 Remote sensing and programming can be used, though the strapping arrangements shown in Figure 3-8 show local sensing and programming.

3-48 Auto-Series Operation (Figure 3-9)

3-49 Two (maximum) SCR-10 power supplies can be operated in Auto-Series to obtain a higher voltage than that available from a single supply. When this connection is used, the output voltage of the slave supply varies in accordance with that of the master supply. At maximum output voltage, the voltage of the slave is determined by the setting of the front panel VOLTAGE controls on the master. The master supply must be the most positive supply of the series. The output CURRENT controls of the slave unit are operative and the current limit is equal to the lowest control setting. If any of the output CURRENT controls are set too low, automatic crossover to constant current operation will occur and the output voltage will drop. Remote sensing and programming can be used, though the strapping arrangements shown in Figure 3-9 show local sensing and programming.

CAUTION

Model 6483C, of the SCR-10 Series, cannot be operated in Auto-Series because this supply can not be floated at more than 100Vdc off ground. However, "Auto-Tracking" can be utilized to obtain coordinated positive and negative voltages if the center tap of the combination is grounded (refer to Paragraph 3-52).

3-50 In order to maintain the temperature coefficient and stability specifications of the power supply, the external resistors (R_X) shown in Figure 3-9 should be stable, low noise, low temperature coefficient (less than 30ppm per degree Centigrade) resistors. The value of each resistor is dependent on the maximum voltage rating of the "master" supply. The value of R_X is this voltage divided by the Constant Voltage programming current of the slave supply ($1/K_p$ where K_p is the resistance programming coefficient). The voltage contribution of the slave is determined by its voltage control setting.

3-51 Protection diodes (CR₅), connected across the output

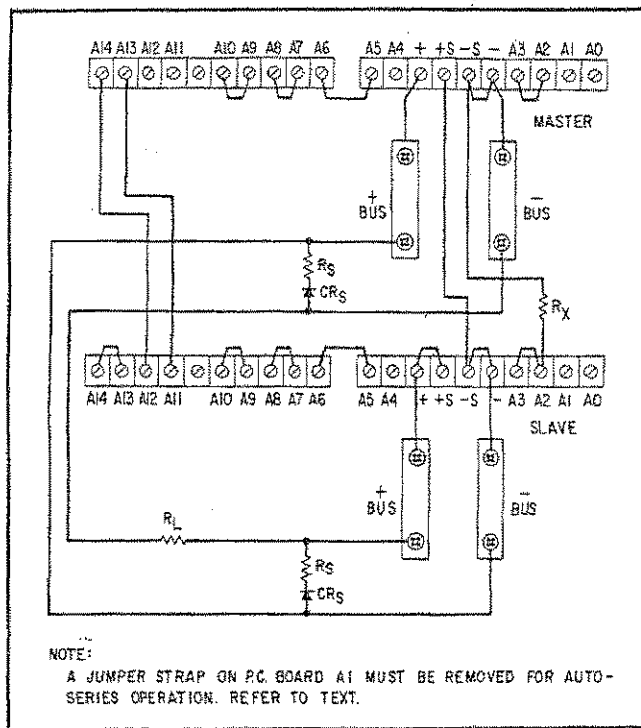

Figure 3-9. Auto-Series Operation

of each supply, prevent internal damages that could occur from reverse voltages if one supply is turned on before the other. On six models in the SCR-10 Series, current limiting resistors are required. Values and part numbers for the resistors and diodes are given in the chart below.

Model	CRs Commercial/HP Part No.	RS Value
6464C	A295F/1901-0336	Not required
6466C	A90F/1901-0335	Not required
6469C	A90A/1901-0338	0.02Ω
6472C	1N3289/1901-0307	0.03Ω
6475C	1N1187A/1901-0320	0.08Ω
6477C	S3270/1901-0326	0.20Ω
6479C	S3270/1901-0326	0.25Ω
6483C	S3270/1901-0326	0.75Ω

3-52 When the center tap of an Auto-Series combination is grounded, coordinated positive and negative voltages result. This technique is commonly referred to as "rubber-banding" and an external reference source may be employed if desired. Any change of the internal or external reference source (e.g., drift, ripple) will cause an equal percentage change in the outputs of both the master and slave supplies. This feature can be of considerable use in analog computer and other applications, where the load requires a positive and a negative power supply and is less susceptible to an output voltage change occurring simultaneously in both supplies than to a change in either supply alone.

3-53 Battery Charging

3-54 The automatic crossover between constant voltage and constant current displayed by the SCR-10 Series makes it an ideal supply for battery charging applications. Using this feature, a battery may be charged at a constant current until the maximum charge voltage is reached at which point the supply will revert to constant voltage and continue to supply a trickle charge current sufficient to maintain full charge (see Figure 3-10). Thus, the charging operation can be unattended after properly setting the charging rate and the maximum charge voltage and connecting the battery to the output terminals of the supply.

3-55 The procedure for setting the charging rate and full charge voltage on SCR-10 Series power supplies is as follows:

- Turn both the VOLTAGE and CURRENT controls fully counterclockwise (CCW).
- Place a short circuit across the output terminals and rotate the VOLTAGE control fully clockwise (CW).
- Rotate the CURRENT control to the desired charging rate as read on the front panel ammeter.
- Rotate VOLTAGE control fully CCW and remove the short circuit.
- Rotate the VOLTAGE control to the desired full charge voltage as read on either the front panel voltmeter (2% accuracy) or a more precise voltage standard. The unit may then be connected to the battery terminals, positive to positive and negative to negative.

3-56 Protection diode CRp prevents a charged battery from discharging into the supply if the supply is turned off.

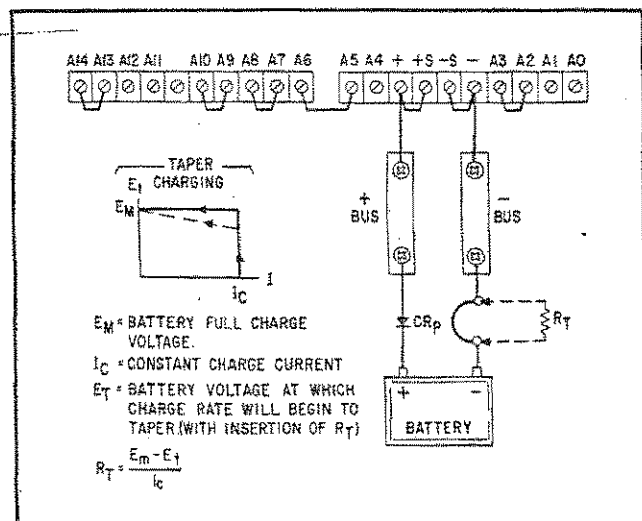

Figure 3-10. Battery Charging

NOTE

A large battery, connected as a load, presents a large capacitance across the output terminals. This capacitance could cause the supply to oscillate; particularly if remote sensing is employed. To stabilize the supply, potentiometer A1R48 may be readjusted (increase resistance) as outlined in Paragraph 5-88. If the maximum resistance of R48 is not sufficient, jumper (R58) can be removed and an additional resistance substituted in series with the potentiometer.

3-57 Taper Charge. For charging lead-acid cells, the charging current should be reduced when the battery is nearing completion of its charge. This is accomplished by inserting a small resistance (R_T) in series with one of the load leads from the supply to the battery which alters the normally rectangular charging plot in such a manner as to provide a taper charge for the last portion of the charge cycle. The value of this resistance is the difference between the full charge voltage and the voltage at which the tapering is to start, divided by the maximum charging current.

3-58 Battery Discharging

3-59 Automatic constant current, unattended discharging of a battery using the SCR-10 Series requires certain changes in the strapping configuration on the rear barrier strip as illustrated in Figure 3-11. Also, a jumper strap on P.C. Board A1 must be removed (see Figure 7-1 for location). Removal of this jumper ensures that the internal programming current does not flow into terminal A2. Before operation, the user should make sure that the interconnecting leads between supply and battery are secure and cannot become opened.

3-60 The supply initially operates in constant current mode at the value set by the current control. When the battery voltage is high the supply output voltage will be low, and as the battery discharges the supply output voltage increases. A constant voltage is maintained across R_X (constant current through R_X). This condition will prevail until the battery voltage drops to zero. At this point, the supply will switch off and no more current will flow through R_X . Diode CR_p protects the supply against reverse voltages. As shown on Figure 3-11, R_X must be selected so that its IR drop is less than the maximum rated output of the supply yet greater than the battery voltage.

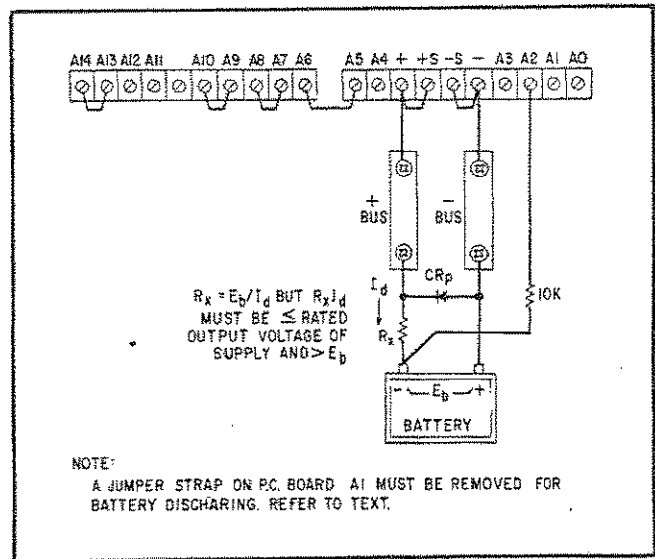

Figure 3-11. Battery Discharging

3-61 The procedure for the connection of the components in this configuration is as follows:

- a. Turn off the power supply and rotate the current control full counterclockwise. (The voltage control will be disconnected by step b.)
- b. Remove the designated jumpers (A2 to A3 and P.C. Board) and connect A2 to the negative terminal of the battery through 10k resistor.
- c. Connect the negative terminal of the supply to the positive terminal of the battery.
- d. Insert R_X between the positive terminal of the supply and the negative terminal of the battery, energize the supply and rotate the current control to the desired discharge current as read on the front panel meter.

3-62 SPECIAL OPERATING CONSIDERATIONS

3-63 Pulse Loading

3-64 The power supply will automatically cross over from constant voltage to constant current operation, or the reverse, in response to an increase (over the preset limit) in the output current or voltage, respectively. Although the preset limit may be set higher than the average output current or voltage, high peak currents or voltages (as occur in pulse loading) may exceed the preset limit and cause crossover to occur. If this crossover limiting is not desired, set the preset limit for the peak requirement and not the average.

