

***SERVICE MANUAL***  
**600 AND 500 WATT  
ELECTRONIC LOAD MODULES  
Agilent 60504B AND 60507B**

**Part No. 60504-90011**

**SERVICE MANUAL  
FOR INSTRUMENTS WITH SERIAL NUMBERS  
Agilent 60504B US37240101 AND ABOVE  
Agilent 60507B US37140101 AND ABOVE**

**For instruments with higher Serial Numbers,  
a change page may be included.**

**Microfiche Part No. 60504-90012**

**Printed in USA: September, 1999**

## **CERTIFICATION**

*Agilent Technologies certifies that this product met its published specifications at time of shipment from the factory. Agilent Technologies further certifies that its calibration measurements are traceable to the United States National Bureau of Standards, to the extent allowed by the Bureau's calibration facility, and to the calibration facilities of other International Standards Organization members.*

## **WARRANTY**

This Agilent Technologies hardware product is warranted against defects in material and workmanship for a period of three years from date of delivery. Agilent Technologies software and firmware products, which are designated by Agilent Technologies for use with a hardware product and when properly installed on that hardware product, are warranted not to fail to execute their programming instructions due to defects in material and workmanship for a period of 90 days from date of delivery. During the warranty period Agilent Technologies will, at its option, either repair or replace products which prove to be defective. Agilent Technologies does not warrant that the operation of the software, firmware, or hardware shall be uninterrupted or error free.

For warranty service, with the exception of warranty options, this product must be returned to a service facility designated by Agilent Technologies. Customer shall prepay shipping charges by (and shall pay all duty and taxes) for products returned to Agilent Technologies for warranty service. Except for products returned to Customer from another country, Agilent Technologies shall pay for return of products to Customer.

Warranty services outside the country of initial purchase are included in Agilent Technologies' product price, only if Customer pays Agilent Technologies international prices (defined as destination local currency price, or U.S. or Geneva Export price).

If Agilent Technologies is unable, within a reasonable time to repair or replace any product to condition as warranted, the Customer shall be entitled to a refund of the purchase price upon return of the product to Agilent Technologies.

## **LIMITATION OF WARRANTY**

The foregoing warranty shall not apply to defects resulting from improper or inadequate maintenance by the Customer, Customer-supplied software or interfacing, unauthorized modification or misuse, operation outside of the environmental specifications for the product, or improper site preparation and maintenance. **NO OTHER WARRANTY IS EXPRESSED OR IMPLIED. AGILENT TECHNOLOGIES SPECIFICALLY DISCLAIMS THE IMPLIED WARRANTIES OF MERCHANTABILITY AND FITNESS FOR A PARTICULAR PURPOSE.**

## **EXCLUSIVE REMEDIES**

**THE REMEDIES PROVIDED HEREIN ARE THE CUSTOMER'S SOLE AND EXCLUSIVE REMEDIES. AGILENT TECHNOLOGIES SHALL NOT BE LIABLE FOR ANY DIRECT, INDIRECT, SPECIAL, INCIDENTAL, OR CONSEQUENTIAL DAMAGES, WHETHER BASED ON CONTRACT, TORT, OR ANY OTHER LEGAL THEORY.**

## **ASSISTANCE**

*The above statements apply only to the standard product warranty. Warranty options, extended support contracts, product maintenance agreements and customer assistance agreements are also available. Contact your nearest Agilent Technologies Sales and Service office for further information on Agilent Technologies' full line of Support Programs.*

## SAFETY SUMMARY

*The following general safety precautions must be observed during all phases of operation, service and repair of this instrument. Failure to comply with these precautions or with specific warnings elsewhere in this manual violates safety standards of design, manufacture, and intended use of the instrument. Agilent Technologies assumes no liability for the customer's failure to comply with these requirements.*

### **BEFORE APPLYING POWER.**

Verify that the product is set to match the available line voltage and the correct fuse is installed.

### **GROUND THE INSTRUMENT.**

This product is a Safety Class 1 instrument (provided with a protective earth terminal). To minimize shock hazard, the instrument chassis and cabinet must be connected to an electrical ground. The instrument must be connected to the ac power supply mains through a three-conductor power cable, with the third wire firmly connected to an electrical ground (safety ground) at the power outlet. For instruments designed to be hard-wired to the ac power lines (supply mains), connect the protective earth terminal to a protective conductor before any other connection is made. Any interruption of the protective (grounding) conductor or disconnection of the protective earth terminal will cause a potential shock hazard that could result in personal injury. If the instrument is to be energized via an external autotransformer for voltage reduction, be certain that the autotransformer common terminal is connected to the neutral (earth pole) of the ac power lines (supply mains).

### **FUSES.**

Only fuses with the required rated current, voltage and specified type (normal blow, time delay, etc.) should be used. Do not use repaired fuses or short-circuited fuseholders. To do so could cause a shock or fire hazard.

### **DO NOT OPERATE IN AN EXPLOSIVE ATMOSPHERE.**

Do not operate the instrument in the presence of flammable gases or fumes.

### **KEEP AWAY FROM LIVE CIRCUITS.**

Operating personnel must not remove instrument covers. Component replacement and internal adjustments must be made by qualified service personnel. Do not replace components with power cable connected. Under certain conditions, dangerous voltages may exist even with the power cable removed. To avoid injuries, always disconnect power, discharge circuits and remove external voltage sources before touching components.

### **DO NOT SERVICE OR ADJUST ALONE.**

Do not attempt internal service or adjustment unless another person capable of rendering first aid and resuscitation, is present.

### **DO NOT EXCEED INPUT RATINGS.**

This instrument may be equipped with a line filter to reduce electromagnetic interference and must be connected to a properly grounded receptacle to minimize electric shock hazard. Operation at line voltages or frequencies in excess of those stated on the line rating label may cause leakage currents in excess of 5.0 mA peak.

### **SAFETY SYMBOLS.**



Instruction manual symbol: the product will be marked with this symbol when it is necessary for the user to refer to the instruction manual (refer to Table of Contents).



Indicates hazardous voltages.



Indicate earth (ground) terminal.

**WARNING**

The WARNING sign denotes a hazard. It calls attention to a procedure, practice, or the like, which, if not correctly performed or adhered to, could result in personal injury. Do not proceed beyond a WARNING sign until the indicated conditions are fully understood and met.

**CAUTION**

The CAUTION sign denotes a hazard. It calls attention to an operating procedure, or the like, which, if not correctly performed or adhered to, could result in damage to or destruction of part or all of the product. Do not proceed beyond a CAUTION sign until the indicated conditions are fully understood and met.

### **DO NOT SUBSTITUTE PARTS OR MODIFY INSTRUMENT.**

Because of the danger of introducing additional hazards, do not install substitute parts or perform any unauthorized modification to the instrument. Return the instrument to an Agilent Technologies Sales and Service Office for service and repair to ensure that safety features are maintained.

*Instruments which appear damaged or defective should be made inoperative and secured against unintended operation until they can be repaired by qualified service personnel.*

## Table of Contents

<b>General Information.....</b>	<b>5</b>
About This Manual .....	5
Troubleshooting Precautions .....	5
Manual Revisions .....	5
Module Initialization.....	6
<b>Verification.....</b>	<b>7</b>
Introduction .....	7
Test Equipment Required .....	7
CC Mode Test.....	8
CV Mode Test .....	9
CR Mode Test.....	10
Transient Operation and Slew Circuit Test.....	12
CC Mode PARD Test .....	13
CC Mode Power Limit.....	13
<b>Replaceable Parts.....</b>	<b>19</b>
Introduction .....	19
How To Order Parts.....	19
<b>Diagrams.....</b>	<b>33</b>
Schematic Diagrams .....	33
Component Location Diagrams .....	33

# General Information

---

## About This Manual

This manual is designed to be used along with the Agilent 6050A/6051A Service Manual. It includes service information that is specific to the 60504B/60507B Modules. Troubleshooting information such as fault isolation, signature analysis, and block-level troubleshooting is the same for all modules and is found in the Agilent 6050A/6051A Electronic Load Mainframe Service Manual. The mainframe Service Manual also explains how to safely disassemble and connect the module to the mainframe for troubleshooting.

Typically, you will need to refer to this manual when you are performing the verification routines, locating a test point on the component/test point diagram, referring to the schematics for additional troubleshooting information, and initializing the module after replacing the EEPROM.

You will also need to refer to this manual for identifying and locating replaceable parts. The parts list identifies all replaceable parts in the module, and the component/test point diagram identifies the location of all electrical parts in your module.

---

## Troubleshooting Precautions

**WARNING**

Use extreme caution when troubleshooting the module when it is connected to the mainframe. AC mains voltage is present on the exposed pins on the top edge of the mainframe GPIB board and each module whenever the units are turned on.

**CAUTION**

Observe all standard antistatic procedures when handling the module assemblies to avoid the possibility of electrostatic damage (refer to mainframe Service Manual).

To reduce the risk of electrical shock when troubleshooting a defective module, make sure the GPIB board is installed in the mainframe. Also, to make it easier to troubleshoot the module, connect the module to the GPIB board using an extender service cable (P/N 06050-60030). This cable is included with the Service kit (P/N 06050-60004), which must be ordered separately.

---

## Manual Revisions

Agilent Technologies instruments are identified by a ten-character serial number such as US37240101. This manual was written for Electronic Load Modules with serial numbers equal to and higher than those shown on the title page. If the serial number of your module is higher than the one shown on the title page, then the module may have hardware or firmware differences that are not covered in this manual. If there are such differences, they are documented in one or more Manual Change sheets sent with this manual.

---

## Module Initialization

EEPROM chip U342 on the Control Board stores the module's GPIB address and model number as well as other constants. The EEPROM was programmed with the proper constants at the factory. If the Control board or the EEPROM chip (U342) is replaced, the module must be reinitialized with the proper constants by programming the following commands in the order indicated. After it has been initialized, the module must also be recalibrated as described in the Operating Manual.

### 60504B Initialization

"CAL 1"	! turn calibration mode on
"CAL: INIT 60 , 120"	! initialize default calibration parameters
"CAL:SAVE"	! store calibration constants in EEPROM
"DIAG:CAL:SEC -5032"	! model number
"DIAG: CAL: SEC 1,16896"	! model number suffix
"DIAG: CAL: SEC 26 , 2"	! module width
"DIAG: CAL: SEC 27 , 1"	! module type
"DIAG: CAL: SEC 28 , 17804"	! voltage for soft over power
"DIAG:CAL:SEC 29 , 3550"	! current for soft over power
"*RST"	! reset factory default state
" CURR : SLEW 2.0E6"	! turn on slew rate
"*SAV 0"	! to location 0
"CAL 0"	! turn calibration mode off

### 60507B Initialization

"CAL 1"	! turn calibration mode on
"CAL: INIT 150 , 60"	! initialize default calibration parameters
"CAL:SAVE"	! store calibration constants in EEPROM
"DIAG:CAL:SEC -5029"	! model number
"DIAG: CAL: SEC 1 , 16896"	! model number suffix
"DIAG: CAL: SEC 26 , 2"	! module width
"DIAG: CAL: SEC 27 , 1"	! module type
"DIAG: CAL: SEC 28 , 1733"	! voltage for soft over power
"DIAG:CAL:SEC 29 , 30000"	! current for soft over power
"*RST"	! reset factory default state
"CURR : SLEW 1.0E6"	! turn on slew rate
"*SAV 0"	! to location 0
"CAL 0"	! turn calibration mode off

## Verification

### Introduction

This chapter contains test procedures that check the operation and calibration of a Agilent 60504B/60507B Electronic Load Modules. The tests are performed from the front panel of an Agilent 6050A/6051A Electronic Load Mainframe with the module installed in slot 1. The tests can also be used to determine which circuits are faulty when troubleshooting. There are some transient, trigger, and pulse functions that require an GPIB controller and will not be verified with manual testing from the front panel. The following tests will verify, with a high level of confidence, that the module is operating properly without testing all of its capabilities.

At the end of this chapter are performance record tables where actual measured values can be recorded.

### Test Equipment Required

Table 2-1 lists the test equipment required to perform the tests in this chapter. Test setups for the tests are shown in Figures 2-1 through 2-3. Make sure the sense switch on the rear of the module is set to the LCL position since local sensing is used in all of the test setups. Use adequate wire gauge when making connections (see Chapter 3 in the Operating Manual).

**Note** The Electronic Load must pass the selftest at power turn-on before the following tests can be performed. If the unit fails selftest, refer to the overall troubleshooting procedures in the mainframe Service Manual.

**Table 2-1. Test Equipment Required for Verification**

Type	Required Characteristics	Recommended Model
200V/60A Source	0 to 20V/0 to 120A 0 to 60V/0 to 50A 0 to 20V/0 to 17A	Agilent 6031A or equivalent Agilent 6032A or equivalent Agilent 6030A or equivalent
Current Monitor Resistor	0.100 ohms @ 15A 0.04% @ 25W	Guideline 9230/15
Current Monitor Resistor	0.010 ohms @ 100A 0.04% @ 100W	Guideline 9230/100
Digital Voltmeter	dc accuracy of 0.01% 6 digit readout	Agilent 3455A, 3456A, or 3458A
Current Probe with Amplifier and Power Supply	Sensitivity of 1mA/10 mV to 50MHz with less than 300µA of noise to 5MHz.	Tektronix A6302 probe, AM503 probe amplifier, and TM501 probe power supply.
Oscilloscope	Sensitivity: 1mV Bandwidth: 20MHz	Agilent 54504

## CC Mode Test

This test verifies that the module operates in the CC Mode and that the current programming and readback to the front panel display are within specifications. For each DMM reading, the front panel display should be equal to:

**60504B:** DMM reading in amps  $\pm ((\text{DMM reading in amps} \times 0.001) + 0.110)$ .

**60507B:** DMM reading in amps  $\pm ((\text{DMM reading in amps} \times 0.001) + 0.065)$ .

If the test readings significantly disagree with the specified values or no readings can be recorded, perform the CC MODE TEST troubleshooting procedures in Figure 3-1 in Chapter 3 of the mainframe Service Manual. If the readings are out of tolerance, calibrate the applicable current range (see Chapter 6 in the Operating Manual).

- a. Connect the Electronic Load, power supply (Agilent 6031A or equivalent), DMM, and current monitor resistor (0.001 ohm for 60504B; 0.010 ohm for 60507B) as shown in Figure 2-1.

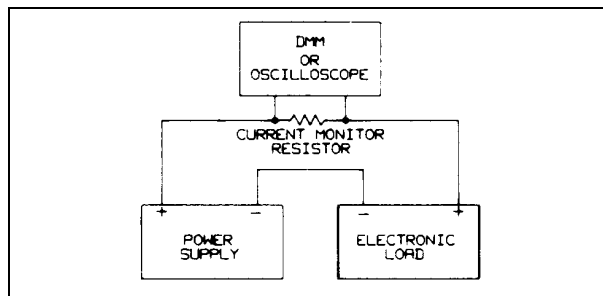

Figure 2-1. Test Setup A

- b. Turn on the Electronic Load.
- c. Check the high amp current range as follows:
  1. Press **MODE** **CURR** **Enter**, then  
**60504B:** **CURR** **1** **2** **0** **Enter**.  
**60507B:** **CURR** **6** **0** **Enter**.
  2. Turn on the power supply and set for:  
**60504B:** 5V and >120A.  
**60507B:** 5V and >60A.
  3. Wait 30 seconds and then record the DMM and front panel display readings. DMM reading should be between:  
**60504B:** 119.73mV (119.73A) and 120.27mV (120.27A).  
**60507B:** 598.6mV (59.86A) and 601.4 mV (60.14A).  
Note that the Electronic Load's CC annunciator is on.
  4. Press **CURR** **1** **Enter**.
  5. Wait 30 seconds then record the DMM and front panel display readings. DMM reading should be between:  
**60504B:** 0.868mV (0.868A) and 1.131mV (1.131A).  
**60507B:** 9.19mV (0.919A) and 10.81mV (1.081A).



d. Check the low current range as follows:

1. Press

**60504B:** **Range** **1** **2** **Enter** then **CURR** **1** **2** **Enter** .

**60507B:** **Range** **6** **Enter** then **CURR** **6** **Enter** .

2. Wait 10 seconds then record the DMM and front panel display readings. DMM reading should be between:

**60504B:** 11.855mV (11.855A) and 12.144mV (12.144A).

**60507B:** 59.14mV (5.914A) and 60.86mV (6.086A).

3. Press **CURR** **1** **Enter** .

4. Wait 10 seconds and record the DMM and front panel display readings. DMM reading should be between:

**60504B:** 0.868mV (0.868A) and 1.131mV (1.131A).

**60507B:** 9.19mV (0.919A) and 10.81mV (1.081A).

---

## CV Mode Test

This test verifies that the module operates in the CV Mode and that the voltage programming and readback to the front panel display are within specifications. For each DMM reading, the corresponding front panel display should be equal to:

**60504B:** DMM reading  $\pm ((\text{DMM reading} \times 0.001) + .045)$ .

**60507B:** DMM reading  $\pm ((\text{DMM reading} \times 0.001) + .090)$ .

Note that if the test readings significantly disagree with the specified values or no readings can be recorded, perform the CV MODE TEST troubleshooting procedures in Figure 3-1, in Chapter 3 of the mainframe Service Manual. If the readings are out of tolerance, calibrate the voltage range (see Chapter 6 in the Operating Manual).

a. Connect the Electronic Load, power supply (HP6032A, 6030A or equivalent), and DMM as shown in Figure 2-2. Take care in making connections so that contact resistance voltage drop will not affect the readings.

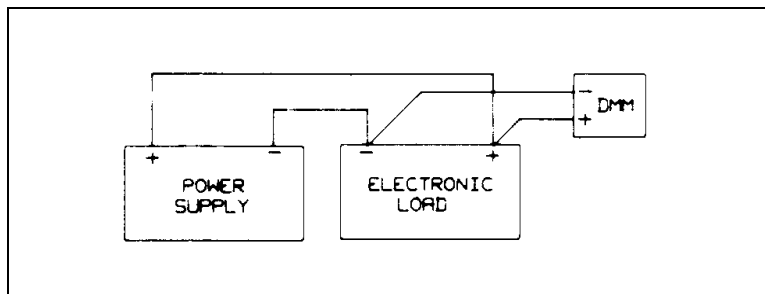

Figure 2-2. Test Setup B

b. Press **MODE** **VOLT** **Enter** , then

**60504B:** **VOLT** **6** **0** **Enter** .

**60507B:** **VOLT** **1** **5** **0** **Enter** .

c. Set power supply for:

**60504B:** 61V and 9A.

**60507B:** 155V and 3A.

d. Record the DMM and front panel display readings. DMM reading should be between:

**60504B:** 59.890V and 60.110V.

**60507B:** 149.725V and 150.275V.

Note that the Electronic Load's CV annunciator is on.

e. Press **VOLT** **3** **Enter** .

f. Record the DMM and front panel display readings. DMM reading should be between:

**60504B:** 2.947V and 3.053V.

**60507B:** 2.872V and 3.128V.

---

## CR Mode Test

This test verifies that the module operates in the CR Mode and that the resistance programming is within specifications. The programmed resistance values are checked by recording the voltage across the current monitor resistor and the input voltage (voltage across the module's input terminals), and then calculating the resistance value as follows:

$$\text{Load resistance} = \text{Input voltage}/(\text{voltage across resistor}/\text{resistor value})$$

Note if the calculation significantly disagrees with the specified range of values, perform the CR MODE TEST troubleshooting procedures in Figure 3-1 in Chapter 3 of the mainframe Service Manual. If the calculation is out of tolerance, calibrate the applicable resistance range (see Chapter 6 in the Operating Manual).

a. Connect the Electronic Load, power supply (Agilent 6032A, 6030A or equivalent), and the current monitor resistor (0.010 ohm for 60504B; 0.100 ohm for 60507B) as shown in Figure 2-1. Use the DMM to measure the voltage across the monitor resistor and across the module's input terminals.

b. Check the low ohm range as follows:

1. Press **MODE** **RES** **Enter** , then

**60504B:** **Range** **0** **.** **4** **Enter** ;

**RES** **0** **.** **5** **Enter** .

**60507B:** **Range** **1** **Enter** ;

**RES** **2** **.** **4** **Enter** .

2. Turn on power source and set for:

**60504B:** 15V and 2.2A.

**60507B:** 30V and 10.9A.

For the low ohm range test, the power supply will operate in the current limit mode.

3. Measure the voltage across the monitor resistor and across the module's input terminals, then calculate the Electronic Load resistance. The result should be between:

**60504B:** 0.491 and 0.509 ohms.

**60507B:** 2.364 and 2.435 ohms.

Note that the Electronic Load's CR annunciator is on.

4. Then press:

**60504B:** **RES** **0** **.** **0** **1** **7** **Enter** .

**60507B:** **RES** **0** **.** **5** **Enter** .

5. Measure the voltage across the monitor resistor and across the module's input terminals, then calculate the Electronic Load resistance. The result should be between:  
**60504B:** 0.0118 and 0.0221 ohms.  
**60507B:** 0.480 and 0.520 ohms.

c. Check the middle ohms range as follows:

1. Press **Range** **1** **0** **Enter** , then

**60504B:** **RES** **1** **5** **0** **Enter** .

**60507B** **RES** **7** **5** **Enter** .

2. Set power supply for:

**60504B:** 10.9V and 30A.

**60507B:** 30V and 15A.

3. Measure the voltage across the monitor resistor and across the module's input terminals, then calculate the Electronic Load resistance. The result should be between:

**60504B:** 11.8 and 20.6 ohms.

**60507B:** 54.42 and 120.57 ohms.

4. Then press:

**60504B:** **RES** **0** **.** **5** **1** **Enter** .

**60507B:** **RES** **3** **Enter** .

5. Measure the voltage across the monitor resistor and across the module's input terminals, then calculate the Electronic Load resistance. The result should be between:

**60504B:** 0.504 and 0.516 ohms.

**60507B:** 2.947 and 3.055 ohms.

d. Check the high ohms range as follows: (Use the 0.100 ohm current monitor resistor when checking the high range on the 60504B.)

1. Press:

**60504B:** **Range** **1** **0** **0** **0** **Enter** .

**60507B:** **Range** **2** **5** **0** **0** **1** **Enter** .

then

**60504B:** **RES** **5** **0** **Enter** .

**60507B:** **RES** **1** **5** **0** **Enter** .

2. Set power source for:

**60504B:** 60V and 15A.

**60507B:** 150V and 10A.

3. Measure the voltage across the monitor resistor and across the module's input terminals, then calculate the Electronic Load resistance. Calculation should be between:

**60504B:** 26.3 and 515 ohms.

**60507B:** 85.5 and 607 ohms.

4. Then press:

**60504B:** **RES** **6** **Enter** .

**60507B:** **RES** **3** **1** **Enter** .

5. Measure the voltage across the monitor resistor and across the module's input terminals, then calculate the Electronic Load resistance. The result should be between:
  - 60504B:** 5.40 and 6.74 ohms.
  - 60507B:** 26.7 and 36.8 ohms.

## Transient Operation and Slew Circuit Test

This test verifies transient and slew circuit operation. The slew circuits cannot be calibrated. If slew rise time and/or fall time are not within specifications or the slew circuits are inoperative, perform either the "Transient Generator Troubleshooting", or the "Slew Circuit Troubleshooting" in Chapter 3 of the mainframe Service Manual.

- a. Use the test setup of Figure 2-1 except connect an oscilloscope across the 0.010 current monitor resistor in place of the DMM. Set power supply for 5V and 10A.
- b. Recall the factory default values by pressing **Recall** **7** **Enter** .
- c. Select the low current range by pressing
  - 60504B:** **Range** **1** **2** **Enter** .
  - 60507B:** **Range** **5** **Enter** .
- d. Set up transient operation by pressing **CURR** **1** **Enter** , then
  - 60504B:** **Tran Level** **1** **1** **Enter** .
  - 60507B:** **Tran Level** **6** **Enter** .
- e. Set the slew rate to .05A/μs (50A/ms) by pressing **[Blue Shift]** (blue shift key), then **Slew** **0** **.** **0** **5** **Enter** , then **Tran on/off** .
- f. Adjust the oscilloscope for a single rise or fall time display. Use delayed sweep. The rise time when measured from 10% to 90% or the fall time when measured from 90% to 10% should be between:
  - 60504B:** 120 and 200μs.
  - 60507B:** 60 and 100μs

Note that the Electronic Load's **Tran** annunciator is on.

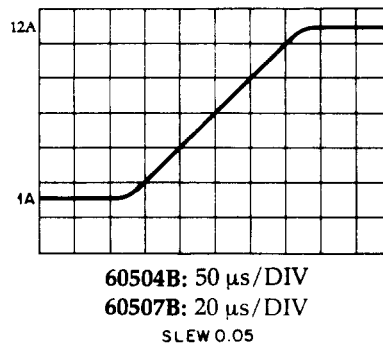

- g. Set the slew rate to .0020 (60504B); .0025A/μs (60507B) by pressing **[Blue Shift]** (blue shift key)
  - 60504B:** **Slew** **0** **.** **0** **0** **2** **0** **Enter** ,
  - 60507B:** **Slew** **0** **.** **0** **0** **2** **5** **Enter** .

- h. Then press **Freq** **6** **0** **Enter** .
- i. Adjust the oscilloscope for a single rise or fall time display. Use delayed sweep. The rise time when measured from 10% to 90% or the fall time when measured from 90% to 10% should be between:  
**60504B**: 3.0 and 5.0ms.  
**60507B**: 1.5 and 2.5ms.

## CC Mode PARD Test

CC mode PARD (periodic and random deviations) is specified as the rms input current in a frequency range 20Hz to 10mhz. This test checks CC Mode PARD.

- a. Connect the Electronic Load, power supply (Agilent 6032A or equivalent, DMM, and current probe as shown in Figure 2-3. Set power supply for 60V and >10A.
- b. Turn the load's ac power off then on.
- c. Press **CURR** **1** **0** **Enter** .
- d. DMM reading should be less than:  
**60504B**: 6mA rms.  
**60507B**: 4mA rms.

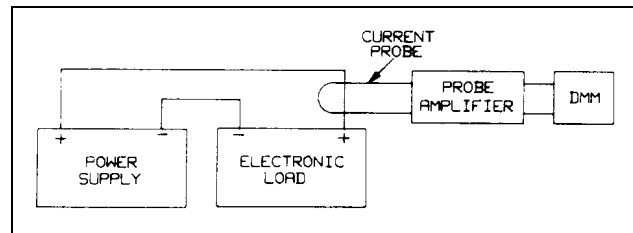

Figure 2-3. Test Setup C

## CC Mode Power Limit

This test verifies that the module's power limit circuit is operating properly. If the results specified in steps d through i are not obtained, troubleshoot the circuits as described in "Overpower Circuits Troubleshooting" in Chapter 3 of the mainframe Service Manual.



If the overpower circuit does not turn the load off within three minutes after performing step d, stop the tests and troubleshoot the overpower circuits.

- a. Connect the Electronic Load and the power source as shown in Figure 2-2.
- b. Turn on the Electronic Load and run for approximately five minutes with no power being dissipated (no input power).
- c. Turn on and set the power supply for 34 volts and 34 amps.

- d. Then press **MODE** **VOLT** **Enter** , then **VOLT** **2** **0** **ENTER** .

The Electronic Load's front panel should indicate approximately

**60504B**: 33 volts and between 27 to 33 amps.

**60507B**: 33 volts and between 23 to 29 amps.

The front panel Prot annunciator should also be on.

- e. Press **Meter** to display "-- OP", indicating that an overpower condition exists and the Electronic Load is in power limit.
- f. Let the Electronic Load continue running. Within three minutes the Electronic Load should turn its input off, and the display should show "PS -- OP" indicating protection shutdown. IF THE OVERPOWER CIRCUIT DOES NOT TURN THE LOAD OFF WITHIN THREE MINUTES, STOP THE TESTS AND TROUBLESHOOT THE OVERPOWER CIRCUITS.
- g. Immediately press **Prot Clear**. The "PS" display should blink and the input will remain shut down, indicating that protection shutdown is latched.
- h. Wait approximately one minute and press **Prot Clear** again. This time the load should turn on with only "OP" displayed.
- i. Reduce the power source output to 20 volts. The display should change to "--" indicating that the protection shutdown and overpower conditions are cleared.

**PERFORMANCE TEST RECORD - Agilent 60504B LOAD MODULE (Page 1 of 2)**

Test Facility:		Report No. _____
_____		Date _____
_____		Customer _____
_____		Tested by _____
Model	<b>Agilent 60504B</b>	Ambient temperature _____ °C
Serial No.	_____	Relative humidity _____ %
Options	_____	Line frequency _____ Hz (nominal)
Firmware Rev.	_____	
Special Notes:		
_____		
_____		
_____		

Description	Model No.	Test Equipment Used	
		Trace No.	Cal. Due Date
1. AC Source	_____	_____	_____
2. DC Voltmeter	Agilent 3458A	_____	_____
3. Oscilloscope	Agilent 54504A	_____	_____
4. Power Source	Agilent 6031A	_____	_____
5. Power Source	Agilent 6032A	_____	_____
6. Current Probe	_____	_____	_____
7. Current Shunt	Guildline 9230/15	_____	_____
8. Current Shunt	Guildline 9230/100	_____	_____
9. Current Shunt	Guildline 9230/300	_____	_____
_____	_____	_____	_____
_____	_____	_____	_____

**PERFORMANCE TEST RECORD - Agilent 60504B LOAD MODULE (Page 2 of 2)**

Model	<b>Agilent 60504B</b>	Report No. _____	Date _____
-------	-----------------------	------------------	------------

Test Description	Minimum Specification	Results	Maximum Specification	Measurement Uncertainty
<b>CONSTANT CURRENT MODE TESTS</b>				
<b>120 Ampere Range</b>				
<b>Programming and Readback</b>				
High Current (120A)	119.726	_____ A	120.274	50mA
Front Panel Display	A <sub>OUT</sub> -0.230	_____ A	A <sub>OUT</sub> +0.230	50mA
Low Current (1A)	0.868	_____ A	1.131	427μA
Front Panel Display	A <sub>OUT</sub> -0.111	_____ A	A <sub>OUT</sub> +0.111	427μA
<b>12 Ampere Range Programming and Readback</b>				
High Current (12A)	11.855	_____ A	12.144	4.9mA
Front Panel Display	A <sub>OUT</sub> -0.122	_____ A	A <sub>OUT</sub> +0.122	4.9mA
Low Current (1A)	0.868	_____ A	1.131	427μA
Front Panel Display	A <sub>OUT</sub> -0.111	_____ A	A <sub>OUT</sub> +0.111	427μA
<b>CONSTANT VOLTAGE MODE TESTS</b>				
<b>Voltage Programming and Readback</b>				
High Voltage (60V)	59.890	_____ V	60.110	845μV
Front Panel Display	V <sub>OUT</sub> -0.105	_____ V	V <sub>OUT</sub> +0.105	845μV
Low Voltage (3V)	2.947	_____ V	3.053	35μV
Front Panel Display	V <sub>OUT</sub> -0.048	_____ V	V <sub>OUT</sub> +0.048	35μV
<b>CONSTANT RESISTANCE MODE TESTS</b>				
<b>Low Resistance Range</b>				
Resistance (0.5 Ω)	0.491	_____ Ω	0.509	
Resistance (0.017Ω)	0.0118	_____ Ω	0.0221	
<b>Middle Resistance Range</b>				
Resistance (15Ω)	11.8	_____ Ω	20.6	
Resistance (0.51 Ω)	0.504	_____ Ω	0.516	
<b>High Resistance Range</b>				
Resistance (50Ω)	26.3	_____ Ω	515	
Resistance (6Ω)	5.40	_____ Ω	6.74	
<b>TRANSIENT SLEW TEST</b>				
<b>Fast Slew Transient</b>				
Slew Rate 0.05 A/μs	120	_____ μs	200	
Slew Rate 2.5 A/μs	3	_____ ms	5	
<b>CONSTANT CURRENT PARD TEST</b>				
Current (10A)	0	_____ mA	6mA RMS	



**PERFORMANCE TEST RECORD - Agilent 60507B LOAD MODULE (Page 1 of 2)**

Test Facility: _____		Report No. _____
_____		Date _____
_____		Customer _____
_____		Tested by _____
Model <b>Agilent 60507B</b>	Ambient temperature _____ °C	
Serial No. _____	Relative humidity _____ %	
Options _____	Line frequency _____ Hz (nominal)	
Firmware Rev. _____		
Special Notes:		
_____		
_____		
_____		

Description	Model No.	Test Equipment Used	
		Trace No.	Cal. Due Date
1. AC Source	_____	_____	_____
2. DC Voltmeter	Agilent 3458A	_____	_____
3. Oscilloscope	Agilent 54504A	_____	_____
4. Power Source	Agilent 6030A	_____	_____
5. Power Source	Agilent 6032A	_____	_____
6. Current Probe	_____	_____	_____
7. Current Shunt	Guildline 9230/15	_____	_____
8. Current Shunt	Guildline 9230/100	_____	_____
_____	_____	_____	_____
_____	_____	_____	_____
_____	_____	_____	_____

**PERFORMANCE TEST RECORD - Agilent 60507B LOAD MODULE (Page 2 of 2)**

Model	Agilent 60507B	Report No. _____	Date _____
-------	----------------	------------------	------------

Test Description	Minimum Specification	Results	Maximum Specification	Measurement Uncertainty
<b>CONSTANT CURRENT MODE TESTS</b>				
<b>60 Ampere Range Programming and Readback</b>				
High Current (60A)	59.860	_____ A	60.140	24mA
Front Panel Display	A <sub>OUT</sub> -0.125	_____ A	A <sub>OUT</sub> +0.125	24mA
Low Current (1A)	0.919	_____ A	1.081	427μA
Front Panel Display	A <sub>OUT</sub> -0.066	_____ A	A <sub>OUT</sub> +0.066	427μA
<b>6 Ampere Range Programming and Readback</b>				
High Current (6A)	5.914	_____ A	6.086	2.5mA
Front Panel Display	A <sub>OUT</sub> -0.071	_____ A	A <sub>OUT</sub> +0.071	2.5mA
Low Current (1A)	0.919	_____ A	1.081	427μA
Front Panel Display	A <sub>OUT</sub> -0.066	_____ A	A <sub>OUT</sub> +0.066	427μA
<b>CONSTANT VOLTAGE MODE TESTS</b>				
<b>Voltage Programming and Readback</b>				
High Voltage (150V)	149.725	_____ V	150.275	20mV
Front Panel Display	V <sub>OUT</sub> -0.240	_____ V	V <sub>OUT</sub> +0.240	20mV
Low Voltage (3V)	2.872	_____ V	3.128	35μV
Front Panel Display	V <sub>OUT</sub> -0.093	_____ V	V <sub>OUT</sub> +0.093	35μV
<b>CONSTANT RESISTANCE MODE TESTS</b>				
<b>Low Resistance Range</b>				
Resistance (2.4 Ω)	2.364	_____ Ω	2.435	
Resistance (0.5Ω)	0.480	_____ Ω	0.520	
<b>Middle Resistance Range</b>				
Resistance (75Ω)	54.42	_____ Ω	120.57	
Resistance (3 Ω)	2.947	_____ Ω	3.055	
<b>High Resistance Range</b>				
Resistance (150Ω)	85.5	_____ Ω	607	
Resistance (31Ω)	26.7	_____ Ω	36.8	
<b>TRANSIENT SLEW TEST</b>				
<b>Fast Slew Transient</b>				
Slew Rate 50 A/ms	60	_____ μs	100	
Slew Rate 2.5 A/ms	1.5	_____ ms	2.5	
<b>CONSTANT CURRENT PARD TEST</b>				
Current (10A)	0	_____ mA	4mA RMS	

## Replaceable Parts

---

### Introduction

Tables 3-3 and 3-4 list the electrical components and Table 3-5 lists the mechanical components for the Agilent 60504B/60507B Electronic Load Modules. These tables provide the following information.

- Reference designation (see Table 3-1).
- Agilent part number.
- Description of part (see Table 3-2).

Refer to Figures 4-2 and 4-4 for component locations.

**Table 3-1. Reference Designators**

A	Assembly	RTB	Removable Terminal Block
B	Blower	RTP	Removable Jumper
C	Capacitor	S	Switch
D	Diode	T	Transformer
F	Fuse	TB	Terminal Block
J	Terminal Jack	TBP	Test Pin
MP	Mechanical Part	U	Integrated Circuit
P	Terminal Plug	VR	Voltage Regulator
Q	Transistor	W	Cable Assembly
RT	Thermal Resistor	Y	Oscillator

---

### How To Order Parts

You can order parts from your local Agilent Technologies sales office (refer to the list at the end of this manual for the office nearest you). when ordering parts, include the following information:

- Agilent part number.
- Description of the part.
- Quantity desired.
- Electronic Load model number (Agilent 60503B).

**Table 3-2. Part Description Abbreviations**

AL	Aluminum	PE	Polyester
CC	Carbon Composition	PD	Power Dissipation
CER	Ceramic	PP	Polypropylene
DIP	Dual In-Line Package	PWR	Power
DPDT	Double Pole Double Throw	RECT	Rectifier
FF	Flip Flop	SIP	Single In-Line Package
FXD	Fixed	TA	Tantalum
GEN-PURP	General Purpose	TC	Temperature Coefficient
IC	Integrated Circuit	TF	Thin Film
MACH	Machine	W/	With
MO	Metal Oxide		

**Table 3-3. Agilent 60504B/60507B Control Board - Electrical Parts**

Reference Designation	Agilent Part Number	Description
	60504-60029	<b>CONTROL BOARD (60504B)</b>
	60507-60022	<b>CONTROL BOARD (60507B)</b>
C301	0180-0405	CAPACITOR-FXD 1.8 $\mu$ F $\pm$ 10% 20Vdc TA
C302	0160-5422	CAPACITOR-FXD .047 $\mu$ F $\pm$ 20% 50Vdc CER
C303,304	0160-4807	CAPACITOR-FXD 33pF $\pm$ 5%100Vdc CER 0 $\pm$ 30
C306,307	0160-5422	CAPACITOR-FXD .047 $\mu$ F $\pm$ 20% 50Vdc CER
C311	0160-6579	CAPACITOR-FXD 2200pF $\pm$ 2.5%100Vdc PP
C312	0160-5349	CAPACITOR-FXD 200pF $\pm$ 5%100Vdc CER 0 $\pm$ 30
C314-317	0160-5422	CAPACITOR-FXD .047 $\mu$ F $\pm$ 20% 50Vdc CER
C323-327	0160-5422	CAPACITOR-FXD .047 $\mu$ F $\pm$ 20% 50Vdc CER
C329	0160-5422	CAPACITOR-FXD .047 $\mu$ F $\pm$ 20% 50Vdc CER
C330	0160-4787	CAPACITOR-FXD 22pF $\pm$ 5%100Vdc CER 0 $\pm$ 30
C331-337	0160-5422	CAPACITOR-FXD .047 $\mu$ F $\pm$ 20% 50Vdc CER
C339	0160-4787	CAPACITOR-FXD 22pF $\pm$ 5% 100Vdc CER 0 $\pm$ 30
C340,341	0160-5422	CAPACITOR-FXD .047 $\mu$ F $\pm$ 20% 50Vdc CER
C342	0160-4822	CAPACITOR-FXD 1000pF $\pm$ 5% 100Vdc CER 0 $\pm$ 30
C343	0160-4835	CAPACITOR-FXD .1 $\mu$ F $\pm$ 10% 50Vdc CER
C344	0160-5422	CAPACITOR-FXD .047 $\mu$ F $\pm$ 20% 50Vdc CER
C345	0160-4835	CAPACITOR-FXD .1 $\mu$ F $\pm$ 10% 50Vdc CER
C346,347	0160-5422	CAPACITOR-FXD .047 $\mu$ F $\pm$ 20% 50Vdc CER
C348	0160-4787	CAPACITOR-FXD 22pF $\pm$ 5%100Vdc CER 0 $\pm$ 30
C349,350	0180-4112	CAPACITOR-FXD 1700 $\mu$ F+30-10% 50Vdc AL
C351	0180-4131	CAPACITOR-FXD 4.7 $\mu$ F $\pm$ 10% 35Vdc TA
C352	0180-3804	CAPACITOR-FXD 47 $\mu$ F $\pm$ 20% 35Vdc TA
C353	0180-4131	CAPACITOR-FXD 4.7 $\mu$ F $\pm$ 10% 35Vdc TA
C357,359	0160-4800	CAPACITOR-FXD 120pF $\pm$ 5%100Vdc CER 0 $\pm$ 30
C363	0160-4820	CAPACITOR-FXD 1800pF $\pm$ 5% 100Vdc CER 0 $\pm$ 30
C365	0160-5422	CAPACITOR-FXD .047 $\mu$ F $\pm$ 20% 50Vdc CER
C366,367	0160-4835	CAPACITOR-FXD .1 $\mu$ F $\pm$ 10% 50Vdc CER
C371	0160-4833	CAPACITOR-FXD 0.22 $\mu$ F $\pm$ 10% 100Vdc CER
C372	0160-4787	CAPACITOR-FXD 22pF $\pm$ 5%100Vdc CER 0 $\pm$ 30
C373	0180-0376	CAPACITOR-FXD .47 $\mu$ F $\pm$ 10% 35Vdc TA
C374	0160-4791	CAPACITOR-FXD 10pF $\pm$ 5%100Vdc CER 0 $\pm$ 30
C375	0160-5422	CAPACITOR-FXD .047 $\mu$ F $\pm$ 20% 50Vdc CER
C376	0160-4835	CAPACITOR-FXD .1 $\mu$ F $\pm$ 10% 50Vdc CER
C377,378	0160-5422	CAPACITOR-FXD .047 $\mu$ F $\pm$ 20% 50Vdc CER
C379	0160-4835	CAPACITOR-FXD .1 $\mu$ F $\pm$ 10% 50Vdc CER
C380,381	0160-4833	CAPACITOR-FXD .022 $\mu$ F $\pm$ 10% 100Vdc CER
C382	0160-4829	CAPACITOR-FXD 680pF $\pm$ 10% 100Vdc CER
C383	0160-4820	CAPACITOR-FXD 1800pF $\pm$ 5% 100Vdc CER
C384	0160-5422	CAPACITOR-FXD .047 $\mu$ F $\pm$ 20% 50Vdc CER
C385	0180-0405	CAPACITOR-FXD 1.8 $\mu$ F $\pm$ 10% 20Vdc TA
C387-389	0160-4835	CAPACITOR-FXD .1 $\mu$ F $\pm$ 10% 50Vdc CER
C391	0160-8153	CAPACITOR-FXD 4700pF 250Vdc

**Table 3-3. Agilent 60504B/60507B Control Board - Electrical Parts (continued)**

<b>Reference Designation</b>	<b>Agilent Part Number</b>	<b>Description</b>
D302-304	1901-0033	DIODE-GEN PURP 180V 200mA IN645
D306,308	1901-0033	DIODE-GEN PURP 180V 200mA IN645
D310-313	1901-0033	DIODE-GEN PURP 180V 200mA IN645
D314-317	1901-0731	DIODE-PWR RECT 400V 1A
D321	1901-0880	DIODE-GEN PURP 200mA DO-35
F300	2110-0716	FUSE-SUBMINIATURE .5A 125V
F301,302	2110-0821	FUSE (METRIC) .315A 250V
J1-3	1252-2789	CONNECTOR-POST RT ANGLE 12-CONTACT
PI-3	60504-80002	CABLE ASSEMBLY W/PLUG 12-CONTACT
P4	60504-80006	CABLE ASSEMBLY W/PLUG 26-CONTACT
Q301	1858-0054	TRANSISTOR ARRAY 16-PIN DIP
R305	0698-4443	RESISTOR 4.53K 1% .125W TF TC=0±100
R306	0698-6320	RESISTOR 5K .1% .125W TF TC=0±25
R307	0698-0085	RESISTOR 2.61K 1% .125W TF TC=0±100
R308	0757-0462	RESISTOR 75K 1% .125W TF TC=0±100
R309	0698-6320	RESISTOR 5K .1% .125W TF TC=0±25
R310,311	0698-8827	RESISTOR 1M 1% .125W TF TC=0±100
R314	0757-0465	RESISTOR 100K 1% .125W TF TC=0±100
R315	0698-0085	RESISTOR 2.61K 1% .125W TF TC=0±100
R316	0699-0924	RESISTOR 11K .1% .125W TF TC=0±25
R317,318	0757-0438	RESISTOR 5.11K 1% .125W TF TC=0±100
R319,320	0698-6360	RESISTOR 10K .1% .125W TF TC=0±25
R321,322	0757-0438	RESISTOR 5.11K 1% .125W TF TC=0±100
R323,324	0698-6360	RESISTOR 10K .1% .125W TF TC=0±25
R325-327	0757-0438	RESISTOR 5.11K 1% .125W TF TC=0±100
R329	0757-0416	RESISTOR 511 1% .125W TF TC=0±100
R330,331	0757-0472	RESISTOR 200K 1% .125W TF TC=0±100
R332	0757-0280	RESISTOR 1K 1% .125W TF TC=0±100
R333	1810-0368	RESISTOR-NET 6-PIN SIP 10.0K X 5
R337	0757-0280	RESISTOR 1K 1% .125W TF TC=0±100
R338	0699-0924	RESISTOR 11K .1% .125W TF TC=0±25
R339,340	0698-6360	RESISTOR 10K .1% .125W TF TC=0±25
R341	0757-0438	RESISTOR 5.11K 1% .125W TF TC=0±100
R342	0757-0449	RESISTOR 20K 1% .125W TF TC=0±100
R343	0698-4443	RESISTOR 4.53K 1% .125W TF TC=0±100
R344	0757-0439	RESISTOR 6.81K 1% .125W TF TC=0±100
R345	0699-0924	RESISTOR 11K .1% .125W TF TC=0±25
R346	0698-6533	RESISTOR 12.5K .1% .125W TF TC=0±25
R347	0757-0438	RESISTOR 5.11K 1% .125W TF TC=0±100
R348	0698-3215	RESISTOR 499K 1% .125W TF TC=0±100
R354	0699-1797	RESISTOR 10M 5%
R355	1810-0280	RESISTOR-NET 10-PIN SIP 10.0K X 9
R356,357	0698-3633	RESISTOR 390 5% 2W MO TC=0±200
R358	0757-0442	RESISTOR 10K 1% .125W TF TC=0±100

**Table 3-3. Agilent 60504B/60507B Control Board - Electrical Parts (continued)**

<b>Reference Designation</b>	<b>Agilent Part Number</b>	<b>Description</b>
R359-361	0757-0424	RESISTOR 1.1K 1% .125W TF TC=0±100
R365 (60504B)	0757-0438	RESISTOR 5.11K 1% .125W TF TC=0±100
R365 (60507B)	0698-3497	RESISTOR 6.04K 1% .125W TF TC=0±100
R368,369	0699-1728	RESISTOR 2.652K .1% .125W TF TC=0±25
R370,371	0698-8672	RESISTOR 243.4 .1% .125W TF TC=0±25
R372	0757-0442	RESISTOR 10K 1% .125W TF TC=0±100
R375	0757-0280	RESISTOR 1K 1% .125W TF TC=0±100
R379	0698-0084	RESISTOR 2.15K 1% .125W TF TC=0±100
R380	0757-0449	RESISTOR 20K 1% .125W TF TC=0±100
R381	0698-4503	RESISTOR 66.5K 1% .125W TF TC=0±100
R382	0698-4486	RESISTOR 24.9K 1% .125W TF TC=0±100
R383	0757-0465	RESISTOR 100K 1% .125W TF TC=0±100
R384	0699-1254	RESISTOR 536K 1% .125W TF TC=0±100
R385	0698-3382	RESISTOR 5.49K 1% .125W TF TC=0±100
R386	0757-0465	RESISTOR 100K 1% .125W TF TC=0±100
R387,388	0757-0442	RESISTOR 10K 1% .125W TF TC=0±100
R389	0757-0436	RESISTOR 4.32K 1% .125W TF TC=0±100
R390	0757-0442	RESISTOR 10K 1% .125W TF TC=0±100
R391	0757-0437	RESISTOR 4.75K 1% .125W TF TC=0±100
R392	0757-0465	RESISTOR 100K 1% .125W TF TC=0±100
R393	0757-0280	RESISTOR 1K 1% .125W TF TC=0±100
R394	0757-0472	RESISTOR 200K 1% .125W TF TC=0±100
R395	0698-8827	RESISTOR 1M 1% .125W TF TC=0±100
R396	0757-0438	RESISTOR 5.11K 1% .125W TF TC=0±100
R397	0698-0084	RESISTOR 2.15K 1% .125W TF TC=0±100
R398	0757-0420	RESISTOR 750 1% .125W TF TC=0±100
R399	0757-0458	RESISTOR 51.1K 1% .125W TF TC=0±100
R400	0757-0455	RESISTOR 36.5K 1% .125W TF TC=0±100
R401	0757-0278	RESISTOR 1.78K 1% .125W TF TC=0±100
R405	0698-3620	RESISTOR 100 5% 2W MO TC=0±200
R406	0764-0041	RESISTOR 30 5% 2W MO TC=0±200
R413,414	0757-0442	RESISTOR 10K 1% .125W TF TC=0±100
R415	0757-0455	RESISTOR 36.5K 1% .125W TF TC=0±100
R416	0757-0442	RESISTOR 10K 1% .125W TF TC=0±100
R417	0757-0401	RESISTOR 100 1% .125W TF TC=0±100
R418	0698-3430	RESISTOR 21.5 1% .125W TF TC=0±100
R420	1810-0280	RESISTOR-NET 10-PIN SIP 10.0K X 9
R421,422	8159-0005	RESISTOR-ZERO OHMS 22 AWG
R423	0757-0401	RESISTOR 100 1% .125W TF TC=0±100
RTB1	0360-2345	MATING PLUG FOR TB301 (control)
RTP301	1258-0209	REMOVABLE JUMPER 2-POSITION
T301	9100-4839	TRANSFORMER-PWR 100/120/220/240V
TB301	0360-2348	TERMINAL BLOCK 10-TERMINAL
TP301	1251-4926	CONNECTOR-POST TYPE 8-CONTACT
U301	5080-2516	IC PROGRAMMABLE MICROPROCESSOR

**Table 3-3. Agilent 60504B/60507B Control Board - Electrical Parts (continued)**

<b>Reference Designation</b>	<b>Agilent Part Number</b>	<b>Description</b>
U302	1820-3399	IC FF CMOS/74HC D-TYPE POS EDGE-TRIG
U303	1820-2228	IC QUAD NAND SET/RESET LATCH CMOS
U304	1820-3079	IC 3-TO-8 LINE DECODER CMOS/74HC
U306	1826-1845	IC DUAL OP AMP 8-PIN DIP (PRECISION)
U307	1826-1317	IC DUAL OP AMP 8-PIN DIP (LOW NOISE)
U308	1826-0962	IC DUAL OP AMP 8-PIN DIP
U309	1826-0850	ANALOG SWITCH 16-PIN DIP
U318	1820-2924	IC QUAD NOR GATE CMOS/74HC 2-INPUT
U319	1820-3399	IC FF CMOS/74HC D-TYPE POS-EDGE-TRIG
U320	1826-1488	D/A CONVERTER CMOS 12-BIT 20-PIN
U321	1826-1068	D/A CONVERTER CMOS 8-BIT 20-PIN
U322	1826-1488	D/A CONVERTER CMOS 12-BIT 20-PIN
U323	1826-0962	IC DUAL OP AMP 8-PIN DIP
U324	1826-1845	IC DUAL PRECISION OP AMP 8-PIN DIP
U325	1826-0962	IC DUAL OP AMP 8-PIN DIP
U326	1826-1081	IC PRECISION OP AMP 8-PIN DIP
U327	1826-1370	IC QUAD COMPARATOR 16-PIN DIP
U328	1826-1081	IC PRECISION OP AMP 8-PIN DIP
U329	1826-1369	IC REGULATOR-FXD 9.95/10.05V 8-PIN DIP
U330	1820-3399	IC FF CMOS/74HC D-TYPE POS-EDGE-TRIG
U332-334	1990-0996	IC LED OPTO-ISOLATOR IF=10mA MAX
U335	1826-0393	IC REGULATOR-ADJUSTABLE 1.2/37V POS
U336	1826-0122	IC REGULATOR-FXD 4.8/5.2V
U337	1826-0527	IC REGULATOR-ADJUSTABLE 1.2/37V NEG
U340	1826-0850	ANALOG SWITCH 16-PIN DIP
U341	1820-3297	IC OCTAL BUS DRIVER CMOS/74HC
U342	1818-4932	IC EEPROM NMOS 1024 (1K)
U344	1826-0962	IC DUAL OP AMP 8-PIN DIP
U345	1820-3399	IC FF CMOS/74HC D-TYPE POS-EDGE-TRIG
U346	1826-0850	ANALOG SWITCH 16-PIN DIP
U347	1826-0412	IC DUAL PRECISION COMPARATOR 8-PIN DIP
U348	1826-1343	IC REGULATOR-ADJUSTABLE 2.5/36V 8-PIN DIP
U349	5080-2137	IC PROGRAMMED GAL
U350	1820-6774	IC BIN COUNTER CMOS/74HC POS-EDGE-TRIG
U351	5080-2121	IC DECADE DIVIDER GATE ARRAY
U352	1820-3172	IC FF CMOS/74HC J-K POS-EDGE-TRIG
U353	1820-3081	IC FF CMOS/74HC D-TYPE POS-EDGE-TRIG
U354,355	1820-3082	IC TRANSCEIVER OCTAL BUS
VR301,302	1902-0957	DIODE-ZENER 9.1V 5% PD=.4W
VR303,304	1902-0783	DIODE-ZENER 16.2V 5% PD=1W
W1	7175-0057	RESISTOR-ZERO OHMS SOLID TINNED COPPER
Y301	0410-1944	RESONATOR-QUARTZ 4.0000MHz

**Table 3-4. Agilent 60504B/60507B Power Board - Electrical Parts**

Reference Designation	Model	Agilent Part Number	Description
	60504B	60504-60026	<b>POWER BOARD</b>
	60507B	60507-60021	<b>POWER BOARD</b>
C1-8	60504B	0160-4820	CAPACITOR-FXD 1800pF ±5% 100Vdc CER
C1-8	60507B	0160-4831	CAPACITOR-FXD 4700pF ±5% 100Vdc CER
C11-21	BOTH	0160-5422	CAPACITOR-FXD .047μF ±20% 50Vdc CER
C25	60504B	0160-7024	CAPACITOR-FXD 2.2μF ±10% 100Vac CER
C25	60507B	0160-5777	CAPACITOR-FXD .68μF ±10% 100Vac CER
C26	60504B	0160-4831	CAPACITOR-FXD 4700pF ±10% 100Vdc CER
C26	60507B	0160-4904	CAPACITOR-FXD 6800pF ±5% 100Vdc CER
C32,33	BOTH	0160-5422	CAPACITOR-FXD .047μF ±20% 50Vdc CER
C34	BOTH	0160-4048	CAPACITOR-FXD .022μF ±20% 250Vac
C35	BOTH	0160-4835	CAPACITOR-FXD .1μF ±10% 50Vdc CER
C36	BOTH	0160-5469	CAPACITOR-FXD 1μF ±10% 50Vdc METAL-PE
C38-42	BOTH	0160-5422	CAPACITOR-FXD .047μF ±20% 50Vdc CER
C49-56	BOTH	0160-4822	CAPACITOR-FXD 1000pF ±5% 100Vdc CER
C60	BOTH	0160-4833	CAPACITOR-FXD .022μF ±10% 100Vdc CER
C74	BOTH	0160-5422	CAPACITOR-FXD .047μF ±20% 50Vdc CER
C76	60504B	0160-4820	CAPACITOR-FXD 1800pF ±5% 100Vdc CER
C76	60507B	0160-4831	CAPACITOR-FXD 4700pF ±5% 100Vdc CER
C77	BOTH	0160-5422	CAPACITOR-FXD .047μF ±20% 50Vdc CER
C78	BOTH	0160-4822	CAPACITOR-FXD 1000pF ±5% 100Vdc CER
C80	60504B	0160-4820	CAPACITOR-FXD 1800pF ±5% 100Vdc CER
C80	60507B	0160-4831	CAPACITOR-FXD 4700pF ±5% 100Vdc CER
C81	BOTH	0160-4822	CAPACITOR-FXD 1000pF ±5% 100Vdc CER
C82	BOTH	0160-5422	CAPACITOR-FXD .047μF ±20% 50Vdc CER
C84	60504B	0160-4820	CAPACITOR-FXD 1800pF ±5% 100Vdc CER
C84	60507B	0160-4831	CAPACITOR-FXD 4700pF ±5% 100Vdc CER
C85	BOTH	0160-5422	CAPACITOR-FXD .047μF ±20% 50Vdc CER
C86	BOTH	0160-4822	CAPACITOR-FXD 1000pF ±5% 100Vdc CER
C87	60504B	0160-4820	CAPACITOR-FXD 1800pF ±5% 100Vdc CER
C87	60507B	0160-4831	CAPACITOR-FXD 4700pF ±5% 100Vdc CER
C88	BOTH	0160-4822	CAPACITOR-FXD 1000pF ±5% 100Vdc CER
C89	BOTH	0160-5422	CAPACITOR-FXD .047μF ±20% 50Vdc CER
C91	60504B	0160-4820	CAPACITOR-FXD 1800pF ±5% 100Vdc CER
C91	60507B	0160-4831	CAPACITOR-FXD 4700pF ±5% 100Vdc CER
C92	BOTH	0160-5422	CAPACITOR-FXD .047μF ±20% 50Vdc CER
C93	BOTH	0160-4822	CAPACITOR-FXD 1000pF ±5% 100Vdc CER
C94	60504B	0160-4820	CAPACITOR-FXD 1800pF ±5% 100Vdc CER
C94	60507B	0160-4831	CAPACITOR-FXD 4700pF ±5% 100Vdc CER
C95	BOTH	0160-4822	CAPACITOR-FXD 1000pF ±5% 100Vdc CER
C96	BOTH	0160-5422	CAPACITOR-FXD .047μF ±20% 50Vdc CER
C98	60504B	0160-4820	CAPACITOR-FXD 1800pF ±5% 100Vdc CER
C98	60507B	0160-4831	CAPACITOR-FXD 4700pF ±5% 100Vdc CER



**Table 3-4. Agilent 60504B/60507B Power Board - Electrical Parts (continued)**

Reference Designation	Model	Agilent Part Number	Description
C99	BOTH	0160-5422	CAPACITOR-FXD .047μF ±20% 50Vdc CER
C100	BOTH	0160-4822	CAPACITOR-FXD 1000pF ±5% 100Vdc CER
C102	60504B	0160-4820	CAPACITOR-FXD 1800pF ±5% 100Vdc CER
C102	60507B	0160-4831	CAPACITOR-FXD 4700pF ±5% 100Vdc CER
C103	BOTH	0160-4822	CAPACITOR-FXD 1000pF ±5% 100Vdc CER
C106	60504B	0160-4833	CAPACITOR-FXD .022μF ±10% 100Vdc CER
C106	60507B	0160-4835	CAPACITOR-FXD .1μF ±10% 100Vdc CER
C125	BOTH	0160-5422	CAPACITOR-FXD .047μF ±20% 50Vdc CER
C126	BOTH	0160-5098	CAPACITOR-FXD .22μF ±10% 50Vdc CER
C127	BOTH	0160-4835	CAPACITOR-FXD .1μF ±10% 50Vdc CER
C128	BOTH	0160-5422	CAPACITOR-FXD .047μF ±20% 50Vdc CER
C129	BOTH	0160-4834	CAPACITOR-FXD .047μF ±10% 100Vdc CER
C130	60504B	0160-7024	CAPACITOR-FXD 2.2μF ±10% 100Vac CER
C130	60507B	0160-5777	CAPACITOR-FXD .68μF ±10% 100Vac CER
C131	60504B	0160-4834	CAPACITOR-FXD .047μF ±10% 100Vdc CER
C131	60507B	0160-6804	CAPACITOR-FXD .047μF ±10% 250Vdc CER
C132	BOTH	0160-4834	CAPACITOR-FXD .047μF ±10% 100Vdc CER
C133-138	BOTH	0160-5422	CAPACITOR-FXD .047μF ±20% 50Vdc CER
C139	BOTH	0160-4801	CAPACITOR-FXD 100pF ±5% 100Vdc CER 0±30
C140	BOTH	0160-4830	CAPACITOR-FXD 2200pF ±10% 100Vdc CER
C141	BOTH	0160-4832	CAPACITOR-FXD .01μF ±10% 100Vdc CER
C142	BOTH	0160-4814	CAPACITOR-FXD 150pF ±5% 100Vdc CER 0±30
C143	BOTH	0160-4832	CAPACITOR-FXD .01μF ±10% 100Vdc CER
C144-146	BOTH	0160-4835	CAPACITOR-FXD .1μF ±10% 50Vdc CER
C147	BOTH	0160-4833	CAPACITOR-FXD .022μF ±10% 100Vdc CER
C148	BOTH	0160-4812	CAPACITOR-FXD 220pF ±5% 100Vdc CER 0±30
C149-151	BOTH	0160-4805	CAPACITOR-FXD 47pF ±5% 100Vdc CER
C152	60504B	0160-4801	CAPACITOR-FXD 100pF ±5% 100Vdc CER 0±30
C152	60507B	0160-4822	CAPACITOR-FXD 1000pF ±5% 100Vdc CER
C153-156	BOTH	0160-4805	CAPACITOR-FXD 47pF ±5% 100Vdc CER
C157	60504B	0160-4801	CAPACITOR-FXD 100pF ±5% 100Vdc CER 0±30
C157	60507B	0160-4822	CAPACITOR-FXD 1000pF ±5% 100Vdc CER
C158-164	BOTH	0160-4805	CAPACITOR-FXD 47pF ±5% 100Vdc CER
C165	BOTH	0160-4834	CAPACITOR-FXD .047μF ±10% 100Vdc CER
C166	BOTH	0160-4832	CAPACITOR-FXD .01μF ±10% 100Vdc CER
C167	BOTH	0160-4831	CAPACITOR-FXD 4700pF ±10% 100Vdc CER
C170			NOT USED
C171	60507B	0160-5777	CAPACITOR-FXD .68μF ±10% 100Vac CER
C172	BOTH	0160-4821	CAPACITOR-FXD 1200pF ±5% 100Vdc CER
C173	60507B	0160-5777	CAPACITOR-FXD .68μF ±10% 100Vac CER
C174	BOTH	0160-4183	CAPACITOR-FXD 1000pF ±20% 250Vdc CER
D10,11	BOTH	1901-0033	DIODE-GEN PURP 180V 200mA IN645
D17-28	BOTH	1901-0033	DIODE-GEN PURP 180V 200mA IN645

**Table 3-4. Agilent 60504B/60507B Power Board - Electrical Parts (continued)**

Reference Designation	Model	Agilent Part Number	Description
D33	BOTH	1901-0880	DIODE-GEN PURP 200mA DO-35
D35	BOTH	1901-0033	DIODE-GEN PURP 180V 200mA 1N645
D45-55	BOTH	1901-0033	DIODE-GEN PURP 180V 200mA 1N645
D56	60504B	1901-0731	DIODE-PWR RECT 400V 1A
D57	BOTH	1901-0880	DIODE-GEN PURP 200mA DO-35
D58			NOT USED
D59	BOTH	1901-0880	DIODE-GEN PURP 200mA DO-35
D60	BOTH	1901-0033	DIODE-GEN PURP 180V 200mA 1N645
D61,63			NOT USED
D62	BOTH	1901-0880	DIODE-GEN PURP 200mA DO-35
F1-8	BOTH	2110-0757	FUSE-SUBMINIATURE .062A 125V
F9-16	BOTH	2110-0697	FUSE-SUBMINIATURE 15A 32V
F17-24	BOTH	2110-0757	FUSE-SUBMINIATURE .062A 125V
F25-32	BOTH	2110-0697	FUSE-SUBMINIATURE 15A 32V
J2	BOTH	1251-4670	CONNECTOR-POST RT ANGLE 9-CONTACT
J4	BOTH	1251-7743	CONNECTOR-POST 26-CONTACT
Q1-4	60504B	1858-0137	FET SUBASSEMBLY (includes 4 FETS)
Q1-4	60507B	1855-0820	FET SUBASSEMBLY (includes 4 FETS)
Q9	BOTH	1855-0386	TRANSISTOR J-FET 2N4392 N-CHANNEL
Q10	BOTH	1854-0635	TRANSISTOR NPN SI PD=50W FT=20MHz
Q11	BOTH	1853-0281	TRANSISTOR PNP SI 2N2907A PD=400mW
Q12	BOTH	1858-0054	TRANSISTOR ARRAY 16-PIN DIP
R1-8	BOTH	06060-80014	RESISTOR .050 3W
R9-16	BOTH	0698-3430	RESISTOR 21.5 1% .125W TF TC=0±100
R17-24	BOTH	0698-3156	RESISTOR 14.7K 1% .125W TF TC=0±100
R25	BOTH	0698-3162	RESISTOR 46.4K 1% .125W TF TC=7±100
R26,27	BOTH	0757-0457	RESISTOR 47.5K 1% .125W TF TC=0±100
R28	BOTH	0757-0124	RESISTOR 39.2K 1% .125W TF TC=7±100
R29	BOTH	0757-0458	RESISTOR 51.1K 1% .125W TF TC=0±100
R30,31	BOTH	0757-0272	RESISTOR 52.3K 1% .125W TF TC=0±100
R32	BOTH	0757-0458	RESISTOR 51.1K 1% .125W TF TC=0±100
R33-40	60504B	0757-0442	RESISTOR 10K 1% .125W TF TC=0±100
R33-40	60507B	0698-6320	RESISTOR 5K 1% .125W TF TC=0±25
R41	BOTH	1810-1260	RESISTOR-NET 10-PIN SIP 20K X 9
R43	BOTH	1810-0316	RESISTOR-NET 16-PIN DIP 10K X 8
R44	BOTH	0757-0280	RESISTOR 1K 1% .125W TF TC=0±100
R46	BOTH	0757-0438	RESISTOR 5.11K 1% .125W TF TC=0±100
R48	BOTH	0698-4479	RESISTOR 14K 1% .125W TF TC=0±100
R50	BOTH	0757-0458	RESISTOR 51.1K 1% .125W TF TC=0±100
R53,54	60504B	0698-6629	RESISTOR 60K .1% .125W TF TC=0±25
R53,54	60507B	0698-6332	RESISTOR 300K .1% .125W TF TC=0±25
R55,56	60504B	0698-6360	RESISTOR 10K .1% .125W TF TC=0±25
R55,56	60507B	0698-6630	RESISTOR 20K 1% .125W TF TC=0±25

**Table 3-4. Agilent 60504B/60507B Power Board - Electrical Parts (continued)**

Reference Designation	Model	Agilent Part Number	Description
R58	60504B	0698-5089	RESISTOR 33K 1% .125W TF TC=0±100
R58	60507B	0757-0124	RESISTOR 39.2K 1% .125W TF TC=7±100
R59	60504B	0757-0457	RESISTOR 47.5K 1% .125W TF TC=0±100
R59	60507B	0698-3162	RESISTOR 46.4K 1% .125W TF TC=0±100
R60	BOTH	0757-0419	RESISTOR 681 1% .125W TF TC=0±100
R63	BOTH	0757-0458	RESISTOR 51.1K 1% .125W TF TC=0±100
R64	BOTH	0757-0455	RESISTOR 36.5K 1% .125W TF TC=0±100
R65	BOTH	0757-0438	RESISTOR 5.11K 1% .125W TF TC=0±100
R66	BOTH	0698-0084	RESISTOR 2.15K 1% .125W TF TC=0±100
R67	BOTH	0757-0420	RESISTOR 750 1% .125W TF TC=0±100
R68	BOTH	0698-6630	RESISTOR 20K .1% .125W TF TC=0±25
R69	BOTH	0699-0620	RESISTOR 2.222K .1% .125W TF TC=0±25
R71	BOTH	0699-0486	RESISTOR 2K .1% .125W TF TC=0±25
R87	BOTH	0757-0458	RESISTOR 51.1K 1% .125W TF TC=0±100
R90	60504B	0698-6360	RESISTOR 10K .1% .125W TF TC=0±25
R90	60507B	0698-6533	RESISTOR 12.5K .1% .125W TF TC=0±25
R92,93	60504B	0698-0083	RESISTOR 1.96K 1% .125W TF TC=0±100
R92,93	60507B	8159-0005	RESISTOR-ZERO OHMS 22 AWG
R94	BOTH	0757-0449	RESISTOR 20K 1% .125W TF TC=0±100
R95	BOTH	0757-0280	RESISTOR 1K 1% .125W TF TC=0±100
R96	60504B	0698-6629	RESISTOR 60K .1% .125W TF TC=0±25
R96	60507B	0757-0467	RESISTOR 121K .1% .125W TF TC=0±25
R101-104	BOTH	1810-1261	RESISTOR-NET 16-PIN DIP MULTI-VALUE
R105	BOTH	0698-6360	RESISTOR 10K .1% .125W TF TC=0±25
R106	BOTH	0698-3572	RESISTOR 60.4K 1% .125W TF TC=0±100
R107	BOTH	0698-3359	RESISTOR 12.7K 1% .125W TF TC=0±100
R108	BOTH	0757-0438	RESISTOR 5.11K 1% .125W TF TC=0±100
R109	BOTH	0757-0449	RESISTOR 20K 1% .125W TF TC=0±100
R110	BOTH	0698-3160	RESISTOR 31.6K 1% .125W TF TC=0±100
R114	BOTH	0757-0447	RESISTOR 16.2K 1% .125W TF TC=0±100
R115	BOTH	0757-0416	RESISTOR 511 1% .125W TF TC=0±100
R116	BOTH	0757-0472	RESISTOR 200K 1% .125W TF TC=0±100
R117	BOTH	0698-6360	RESISTOR 10K .1% .125W TF TC=0±25
R118,119	BOTH	0757-0442	RESISTOR 10K 1% .125W TF TC=0±100
R120	BOTH	0757-0444	RESISTOR 12.1K 1% .125W TF TC=0±100
R121	BOTH	0757-0442	RESISTOR 10K 1% .125W TF TC=0±100
R136	BOTH	0757-0449	RESISTOR 20K 1% .125W TF TC=0±100
R142	BOTH	1810-1274	RESISTOR-NET 10-PIN SIP MULTI-VALUE
R143	BOTH	0757-0420	RESISTOR 750 1% .125W TF TC=0±100
R144	BOTH	0698-4479	RESISTOR 14K 1% .125W TF TC=0±100
R151	BOTH	0698-3160	RESISTOR 31.6K 1% .125W TF TC=0±100
R156	BOTH	0698-3162	RESISTOR 46.4K 1% .125W TF TC=0±100
R157	BOTH	0698-3156	RESISTOR 14.7K 1% .125W TF TC=0±100

**Table 3-4. Agilent 60504B/60507B Power Board - Electrical Parts (continued)**

<b>Reference Designation</b>	<b>Model</b>	<b>Agilent Part Number</b>	<b>Description</b>
R158	BOTH	1810-1261	RESISTOR-NET 16-PIN DIP MULTI-VALUE
R159	BOTH	0698-3430	RESISTOR 21.5 1% .125W TF TC=0±100
R160	60504B	0757-0442	RESISTOR 10K 1% .125W TF TC=0±100
R160	60507B	0698-6320	RESISTOR 5K 1% .125W TF TC=0±25
R161	BOTH	06060-80014	RESISTOR .050 3W
R162	BOTH	1810-1260	RESISTOR-NET 10-PIN SIP 20K X 9
R163	BOTH	0698-3162	RESISTOR 46.4K 1% .125W TF TC=0±100
R164	BOTH	0698-3156	RESISTOR 14.7K 1% .125W TF TC=0±100
R165	BOTH	0698-3430	RESISTOR 21.5 1% .125W TF TC=0±100
R166	60504B	0757-0442	RESISTOR 10K 1% .125W TF TC=0±100
R166	60507B	0698-6320	RESISTOR 5K 1% .125W TF TC=0±25
R167	BOTH	06060-80014	RESISTOR .050 3W
R168	BOTH	0698-3162	RESISTOR 46.4K 1% .125W TF TC=0±100
R169	BOTH	0698-3156	RESISTOR 14.7K 1% .125W TF TC=0±100
R170	BOTH	0698-3430	RESISTOR 21.5 1% .125W TF TC=0±100
R171	BOTH	1810-1261	RESISTOR-NET 16-PIN DIP MULTI-VALUE
R172	60504B	0757-0442	RESISTOR 10K 1% .125W TF TC=0±100
R172	60507B	0698-6320	RESISTOR 5K 1% .125W TF TC=0±25
R173	BOTH	06060-80014	RESISTOR .050 3W
R174	BOTH	0698-3450	RESISTOR 42.2K 1% .125W TF TC=0±100
R175	BOTH	0698-3156	RESISTOR 14.7K 1% .125W TF TC=0±100
R176	BOTH	0698-3430	RESISTOR 21.5 1% .125W TF TC=0±100
R177	60504B	0757-0442	RESISTOR 10K 1% .125W TF TC=0±100
R177	60507B	0698-6320	RESISTOR 5K 1% .125W TF TC=0±25
R178	BOTH	06060-80014	RESISTOR .050 3W
R179	BOTH	0757-0457	RESISTOR 47.5K 1% .125W TF TC=0±100
R180	BOTH	0698-3156	RESISTOR 14.7K 1% .125W TF TC=0±100
R181	BOTH	0698-3430	RESISTOR 21.5 1% .125W TF TC=0±100
R182	BOTH	1810-1261	RESISTOR-NET 16-PIN DIP MULTI-VALUE
R183	60504B	0757-0442	RESISTOR 10K 1% .125W TF TC=0±100
R183	60507B	0698-6320	RESISTOR 5K 1% .125W TF TC=0±25
R184	BOTH	06060-80014	RESISTOR .050 3W
R185	BOTH	0757-0459	RESISTOR 56.2K 1% .125W TF TC=0±100
R186	BOTH	0698-3156	RESISTOR 14.7K 1% .125W TF TC=0±100
R187	BOTH	0698-3430	RESISTOR 21.5 1% .125W TF TC=0±100
R188	60504B	0757-0442	RESISTOR 10K 1% .125W TF TC=0±100
R188	60507B	0698-6320	RESISTOR 5K 1% .125W TF TC=0±25
R189	BOTH	06060-80014	RESISTOR .050 3W
R190	BOTH	0757-0272	RESISTOR 52.3K 1% .125W TF TC=0±100
R191	BOTH	0698-3156	RESISTOR 14.7K 1% .125W TF TC=0±100
R192	BOTH	0698-3430	RESISTOR 21.5 1% .125W TF TC=0±100
R193	BOTH	1810-1261	RESISTOR-NET 16-PIN DIP MULTI-VALUE

**Table 3-4. Agilent 60504B/60507B Power Board - Electrical Parts (continued)**

Reference Designation	Model	Agilent Part Number	Description
R194	60504B	0757-0442	RESISTOR 10K 1% .125W TF TC=0±100
R194	60507B	0698-6320	RESISTOR 5K 1% .125W TF TC=0±25
R195	BOTH	06060-80014	RESISTOR .050 3W
R196	BOTH	0757-0457	RESISTOR 47.5K 1% .125W TF TC=0±100
R197	BOTH	0698-3156	RESISTOR 14.7K 1% .125W TF TC=0±100
R198	BOTH	0698-3430	RESISTOR 21.5 1% .125W TF TC=0±100
R199	60504B	0757-0442	RESISTOR 10K 1% .125W TF TC=0±100
R199	60507B	0698-6320	RESISTOR 5K 1% .125W TF TC=0±25
R200	BOTH	06060-80014	RESISTOR .050 3W
R201	BOTH	0757-0447	RESISTOR 16.2K 1% .125W TF TC=0±100
R202	60504B	0757-0283	RESISTOR 2K 1% .125W TF TC=0±100
R202	60507B	0698-3493	RESISTOR 4.12K 1% .125W TF TC=0±100
R204	60504B	0757-0472	RESISTOR 200K 1% .125W TF TC=0±100
R204	60507B	0698-3215	RESISTOR 499K 1% .125W TF TC=0±100
R205	60504B	0757-0439	RESISTOR 6.81K 1% .125W TF TC=0±100
R205	60507B	0757-0440	RESISTOR 7.5K 1% .125W TF TC=0±100
R206	BOTH	0757-0412	RESISTOR 365 1% .125W TF TC=0±100
R207	BOTH	0757-0472	RESISTOR 200K 1% .125W TF TC=0±100
R208	BOTH	0757-0438	RESISTOR 5.11K 1% .125W TF TC=0±100
R209	BOTH	0683-0475	RESISTOR 4.7 5% .25W CF TC=0-400
R210	BOTH	0698-3160	RESISTOR 31.6K 1% .125W TF TC=0±100
R211	60504B	0757-0280	RESISTOR 1K 1% .125W TF TC=0±100
R211	60507B	0757-0278	RESISTOR 1.78K 1% .125W TF TC=0±100
R212	BOTH	0757-0439	RESISTOR 6.81K 1% .125W TF TC=0±100
R213	60504B	0698-3450	RESISTOR 42.2K 1% .125W TF TC=0±100
R213	60507B	0757-0457	RESISTOR 47.5K 1% .125W TF TC=0±100
R214	60504B	0698-3450	RESISTOR 42.2K 1% .125W TF TC=0±100
R214	60507B	0757-0469	RESISTOR 150K 1% .125W TF TC=0±100
R215	60504B	0757-0462	RESISTOR 75K 1% .125W TF TC=0±100
R215	60507B	0757-0270	RESISTOR 249K 1% .125W TF TC=0±100
R216	BOTH	0757-0278	RESISTOR 1.78K 1% .125W TF TC=0±100
R217-224	BOTH	0757-0465	RESISTOR 100K 1% .125W TF TC=0±100
R225	BOTH	0698-3215	RESISTOR 499K 1% .125W TF TC=0±100
R226	BOTH	2100-3750	RESISTOR-TRIMMER 20K 10%
R231-238	BOTH	0757-0465	RESISTOR 100K 1% .125W TF TC=0±100
R239	BOTH	0683-1065	RESISTOR 10M 5% .25W CC TC=-900/+1100
R240,241	BOTH	0683-0475	RESISTOR 4.7 5% .25W CF TC=0-400
R244	60504B	0812-0047	RESISTOR 5 5% 5W PW
R244	60507B	0811-1224	RESISTOR 3 5% 3W PW
R245-247	60504B	0812-0047	RESISTOR 5 5% 5W PW
R246,247	60507B	0811-1224	RESISTOR 3 5% 3W PW
R248	BOTH	0757-0280	RESISTOR 1K 1% .125W TF TC=0±100
R249	BOTH	0757-0279	RESISTOR 3.16K 1% .125W TF TC=0±100
R250	BOTH	0757-0439	RESISTOR 6.81K 1% .125W TF TC=0±100

**Table 3-4. Agilent 60504B/60507B Power Board - Electrical Parts (continued)**

Reference Designation	Model	Agilent Part Number	Description
R251	BOTH	8159-0005	RESISTOR-ZERO OHMS 22 AWG
R252	BOTH	0757-0280	RESISTOR 1K 1% .125W TF TC=0±100
R253	BOTH	0757-0405	RESISTOR 162 1% .125W TF TC=0±100
R254	BOTH	0757-0419	RESISTOR 681 1% .125W TF TC=0±100
R255	BOTH	0757-0443	RESISTOR 11 1% .125W TF TC=0±100
R256	BOTH	0757-0436	RESISTOR 4.32K 1% .125W TF TC=0±100
R257	BOTH	0757-0463	RESISTOR 82.5K 1% .125W TF TC=0±100
R258	BOTH	0757-0442	RESISTOR 10K 1% .125W TF TC=0±100
R259	BOTH	0757-0438	RESISTOR 5.11K 1% .125W TF TC=0±100
R260	BOTH	0757-0442	RESISTOR 10K 1% .125W TF TC=0±100
R261	BOTH	0757-0447	RESISTOR 16.2K 1% .125W TF TC=0±100
R262	BOTH	0757-0440	RESISTOR 7.5K 1% .125W TF TC=0±100
R263	BOTH	0757-0439	RESISTOR 6.81K 1% .125W TF TC=0±100
R264	BOTH	0698-3156	RESISTOR 14.7K 1% .125W TF TC=0±100
R265	BOTH	0698-0084	RESISTOR 2.15K 1% .125W TF TC=0±100
R266,267	BOTH	0757-0442	RESISTOR 10K 1% .125W TF TC=0±100
R268	BOTH	0698-3226	RESISTOR 6.49K 1% .125W TF TC=0±100
R269,270	BOTH	0757-0442	RESISTOR 10K 1% .125W TF TC=0±100
R271	60504B	8159-0005	RESISTOR-ZERO OHMS 22 AWG
R271	60507B	0698-4503	RESISTOR 66.5K 1% .125W CF TC=0±100
R273-276	BOTH	8159-0005	RESISTOR-ZERO OHMS 22 AWG
R277,279	BOTH	0757-0463	RESISTOR 82.5K 1% .125W TF TC=0±100
R280	BOTH	0757-0442	RESISTOR 10K 1% .125W TF TC=0±100
R281	60504A	0757-0274	RESISTOR 1.21K 1% .125W TF TC=0±100
R281	60507B	0757-0280	RESISTOR 1K 1% .125W TF TC=0±100
R282	60504B	0812-0047	RESISTOR 5 5% 5W PW
R283	BOTH	0698-8913	RESISTOR 1.5M 1% .125W TF TC=0±100
R284	BOTH	0698-0064	RESISTOR 9.31K 1% .125W TF TC=0±100
R285	BOTH	0757-0464	RESISTOR 90.9K 1% .125W TF TC=0±100
R286,287			NOT USED
R288	BOTH	0698-8913	RESISTOR 1.5M 1% .125W TF TC=0±100
R289	BOTH	0698-4536	RESISTOR 340K 1% .125W TF TC=0±100
R290	60504B	0757-0459	RESISTOR 56.2K 1% .125W TF TC=0±100
R290	60507B	0757-0458	RESISTOR 51.1K 1% .125W TF TC=0±100
R291-306	BOTH	0698-8827	RESISTOR 1M 1% .125W TF TC=0±100
R307	60504B	8159-0005	RESISTOR-ZERO OHMS 22 AWG
RT2	BOTH	0837-0397	THERMISTOR 10K (under large heatsink)
S1	BOTH	3101-2894	SENSE SWITCH DPDT
	BOTH	0370-2862	PUSHBUTTON (for sense switch)
TP1	BOTH	1252-1973	CONNECTOR-POST TYPE 20 CONTACT
U1	BOTH	1826-2252	IC DUAL OP AMP 8-PIN DIP LOW NOISE
U2,3	BOTH	1826-1533	IC DUAL OP AMP 8-PIN DIP H-SLEW RATE
U4	BOTH	1826-2252	IC DUAL OP AMP 8-PIN DIP LOW NOISE

**Table 3-4. Agilent 60504B/60507B Power Board - Electrical Parts (continued)**

Reference Designation	Model	Agilent Part Number	Description
U5	BOTH	1826-1533	IC DUAL OP AMP 8-PIN DIP H-SLEW RATE
U6	BOTH	1826-2252	IC DUAL OP AMP 8-PIN DIP LOW NOISE
U7	BOTH	1826-1533	IC DUAL OP AMP 8-PIN DIP H-SLEW RATE
U8	BOTH	1826-2252	IC DUAL OP AMP 8-PIN DIP LOW NOISE
U9	BOTH	1826-0850	IC ANALOG SWITCH 16-PIN DIP
U10	BOTH	1826-0138	IC QUAD COMPARATOR 14-PIN DIP
U11	BOTH	1826-1370	IC QUAD COMPARATOR 16-PIN DIP
U12	BOTH	1826-1533	IC DUAL OP AMP 8-PIN DIP H-SLEW RATE
U13	BOTH	1826-0962	IC DUAL OP AMP 8-PIN DIP LOW BIAS H-IMPD
U14,15	BOTH	1826-2252	IC DUAL OP AMP 8-PIN DIP LOW NOISE
U16	BOTH	1826-0962	IC DUAL OP AMP 8-PIN DIP LOW BIAS H-IMPD
U17	BOTH	1826-0346	IC DUAL OP AMP 8-PIN DIP GP
U18	BOTH	1826-1533	IC DUAL OP AMP 8-PIN DIP H-SLEW RATE
U19	BOTH	1826-2252	IC DUAL OP AMP 8-PIN DIP LOW NOISE
U20	BOTH	1826-1533	IC DUAL OP AMP 8-PIN DIP H-SLEW RATE
U21	BOTH	1826-2252	IC DUAL OP AMP 8-PIN DIP LOW NOISE
U22	BOTH	1826-1533	IC DUAL OP AMP 8-PIN DIP H-SLEW RATE
U23	BOTH	1826-2252	IC DUAL OP AMP 8-PIN DIP LOW NOISE
U24	BOTH	1826-1533	IC DUAL OP AMP 8-PIN DIP H-SLEW RATE
U25	BOTH	1826-2252	IC DUAL OP AMP 8-PIN DIP LOW NOISE
VR10	BOTH	1902-0783	ZENER DIODE 16V 5% PD=1W
VR26	BOTH	1902-3149	ZENER DIODE 9.09V 5% PD=.4W
VR27	BOTH	1902-0761	ZENER DIODE IN821 6.2V 5% PD=.4W
VR28	60504B	1901-1284	VOLTAGE SUPPRESSOR 75V
VR29			NOT USED

**Table 3-5. Agilent 60504B/60507B Mechanical Parts**

Agilent Part Number	Quantity	Description
		<b>CONTROL BOARD</b>
60504-00001	1	MODULE CHASSIS
7121-0850	1	WARNING LABEL
7121-2794	1	SERIAL# LABEL
0515-0413	2	SCREW-MACH M5X0.8X6mm (rear panel to module chassis)
0515-0414	6	SCREW-MACH M4X0.7X10mm (control board to module chassis)
60502-80004	4	SPACER-PLASTIC (align heatsink with module chassis)
1205-0298	1	HEATSINK (U335)
1205-0730	1	HEATSINK (U337)
0515-0104	2	SCREW-MACH M3X0.5 (U335,337)
0535-0031	2	NUT-HEX W/LOCKWASHER M3 (U335,337)
3050-0891	2	WASHER M3 (U335,337)
2110-0689	4	FUSE CLIP (F301,302)

**Table 3-5. Agilent 60504B/60507B Mechanical Parts (continued)**

<b>Agilent Part Number</b>	<b>Quantity</b>	<b>Description</b>
<b>POWER BOARD</b>		
60504-60001	1	LARGE HEATSINK
60504-20002	1	T-BAR HEATSINK (mount for Q1-Q4)
1205-0743	4	THERMAL PAD (between Q1-Q4 and heatsink)
60504-00005	1	HEATSINK BRACKET (connected to large heatsink)
1205-0742	1	THERMAL PAD (between large heatsink and T-bar)
0340-1217	1	INSULATOR (in heatsink for RT2)
0515-0981	6	SCREW-MACH M4X0.7X25mm (Q1-Q4 to T-bar)
0535-0082	6	NUT-HEX M4 (Q1-Q4 to T-bar)
0515-1114	5	SCREW-MACH M4X0.7X10mm (T-bar to power board)
60504-00002	1	REAR PANEL
60504-80005	1	REAR PANEL LABEL(60504B)
60507-80001	1	REAR PANEL LABEL(60507B)
1510-0134	2	BINDING POST ASSEMBLY
3050-1320	2	SPRING STEEL WASHER (on binding post)
2190-0629	2	LOCKWASHER (on binding post)
0535-0020	2	NUT-HEX (on binding post)
0515-0155	2	SCREW-MACH M5X0.8X12mm (binding post to bus bar)
0515-1146	1	SCREW-MACH M3X0.5X6mm (ground wire to chassis)
3050-0891	1	WASHER M3 (ground to chassis)
60504-00003	1	POWER BUS (mounted on board)
60504-00006	1	BUS BAR (- input)
60504-00007	1	BUS BAR (+ input)
0515-0413	7	SCREW MACH M5X0.8X6mm (heatsink bracket to large heatsink; +input bus bar to large heatsink; bus bar to power board)
0515-0414	16	SCREW-MACH M4X0.7X10mm (power board to chassis ; T-bar to large heatsink)
4040-2268	1	SAFETY COVER (rear panel terminal block)
<b>MISCELLANEOUS</b>		
9222-1375	1	BAG, STATIC PROTECTION
60504-80001	1	FLOATER, ANTI-STATIC
60504-80003	2	FLOATER, ANTI-STATIC
9211-6282	1	CARTON, SHIPPING
60504-90009	1	MANUAL, OPERATING (60504B)
60507-90001	1	MANUAL, OPERATING (60507B)
60504-90011	1	MANUAL, SERVICE



## Diagrams

### Schematic Diagrams

Schematic diagrams and component location diagrams are provided for the Control board as well as the Power board on two foldout pages. Two schematic diagrams of the Power board are included in Figure 4-2 on the first foldout; three schematic diagrams of the Control board are included in Figure 4-4 on the second foldout. Table 4-1 lists the notes that apply to both the Control board and Power board schematic diagrams.

Table 4-2 lists, alphabetically, all of the signal names that appear on the schematic, along with a brief description of the signal's function. To help you locate where signals come from and go to, Table 4-1 lists the coordinates for each appearance of a signal on each sheet of the schematic. Coordinates printed in **BOLD** indicate the signal origin. On the Control board for example, when ACLR\* is active, it clears the analog circuits. ACLR\* originates in area 4D of sheet 1 and also appears in area 2B of sheet 3.

**Table 4-1. Schematic Diagram Notes**

1. All resistors are in ohms  $\pm 1\%$ , 1/8 W unless otherwise specified.
2. All capacitors are in microfarads unless otherwise specified.
3. All unmarked capacitors are 0.047 $\mu$ F.
4. An asterisk negates a signal name. For example,  $\overline{CS2}$  appears on the schematic as CS2\*.
5. Signal lines that are terminated by flags continue on other sheets, and may also go to other locations on the same sheet. Table 4-2 documents all signal terminations on the schematics. Note that flags do not indicate signal flow direction.

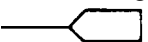
Example:  CC\_PROG

6. Unterminated signal lines go to at least one other location of the same schematic sheet.

Example: SPCLR\*

7. Heavy signal lines represent multiple-wire data buses.
8. Unless otherwise noted, bias connections to IC packages are as follows:

	<b>Common</b>	<b>+5V</b>
14-pin packages	pin 7	pin 14
16-pin packages	pin 8	pin 16
20-pin packages	pin 10	pin 20

9. Values in brackets [ ] apply to model 60507B.

### Component Location Diagrams

Each foldout includes a component locations diagram with a look-up table for locating electrical components. Figure 4-1 gives the component locations for the Control board and Figure 4-3 gives the component locations for the Power board. The coordinates in the look-up table under each diagram reference the grid on the diagram and give the location of some point on each component to within 1/10 of a unit. The mainframe Service Manual gives several examples of how to use the table.

The component locations diagram also indicates specific troubleshooting test point locations. The test points are described in Chapter 3 of the mainframe Service Manual and are used in various troubleshooting procedures described in that chapter.

**Table 4-2. Signal-Name Descriptions**

<b>Mnemonic</b>	<b>Function</b>	<b>Sheet 1</b>	<b>Sheet 2</b>	<b>Sheet 3</b>
<b>CONTROL BOARD</b>				
ACLR*	Analog circuits clear (D)	<b>4D</b>		2B
BO*	Brown out input disable (D)	3D		2A
CC_EN*	CC mode enable (D)	<b>6D</b> , 3B		
CC_PROG	Programming voltage for CC mode (A)	<b>3B</b>	2B	
CCVTST	Comparator output, main DAC self-test (D)	6D	<b>4A</b>	
CG*	CR-mode middle-and-high-range select (D)	<b>5D</b>	4D	
CLR	Initialize transient generator (D)	<b>7B</b> , 5A		
CR*	CR-mode low-range select (D)	<b>5D</b>	3C	2A
CS0*	Main DAC chip select (D)	<b>1D</b> ,	8D	
CS1*	Transient DAC chip select (D)	<b>1D</b>	7C	
CS2*	Slew range chip select (D)	<b>1D</b> , 8C		
CS3*	Readback DAC chip select (D)	<b>1D</b>	8B	
CS4*	Secondary-data-bus buffer chip select (D)	<b>1D</b>	8D	
CS5*	Control-signals latch chip select (D)	<b>1D</b> , 6D		
CS6*	Control-signals latch chip select (D)	<b>7D</b> , 5D		
CS7*	Non-volatile memory R/W chip select (D)	<b>8D</b> 3C, 2C		
CV_EN*	CV mode enable (D)	<b>6D</b> , 3C		
CV_PROG	Programming voltage for CV mode (A)	<b>3C</b>		2C
DAC_REF*	Main DAC reference enable, CV/CC modes (D)	<b>5D</b>	3D	
E	Secondary-μP clock (D)	6D, 8A		
EEPON*	EEPROM power-on disable (D)	2C		<b>2D</b>
EPC_EN*	Extended power capability enable/disable (D)	<b>4D</b>		2A
EXT_PROG	Ext programming input (A) from rear-panel A4			1B, 3C
FLT	Voltage-fault signal (D) to rear-panel A6	<b>3D</b>	1B	
FSEL0,FSEL1,FSEL2	Transient-generator frequency-select bits (D)	<b>5D</b> , 4A		
HIGH*	Transient-DAC output enable (D)	<b>6B</b>	8C	
H/L*	Main-DAC transfer control (D)	<b>7D</b>	8D	
H/L-A/D	Readback-DAC transfer control (D)	<b>7D</b>	8B	
IMON	Current-monitor output (A) to rear-panel A1		<b>1D</b> , 1C	
IMON*	Input-current monitor signal (A)		3D, 6A	2C
	CR-mode low-range DAC reference (A)		4C	
IMONR	Current-monitor-comparator output (D)	6D	<b>4A</b>	
LCLR*	Clear status latch (D)	<b>5D</b> , 3D		
MODULE_INSTALLED*	Indicate how many modules are installed (D)			<b>8B</b>
OP*	Overpower status (D)	3D		2A
OV*	Overvoltage status (D)	3D		2A
PCLR1*	Power-on clear signal from mainframe (D)			<b>8B</b>
PORT	PORT output (D) to rear-panel A7	3D	1B	
PRX	Primary-μP receiver (D)			8A
PTX	Primary-μP transmitter (D)			8A
P_TRIG	Continuous mode pulse trigger (D)	6A, 5D		
PRI TRIG	Trigger signal from mainframe (D)			<b>8B</b>
PULSE_EN	Pulse-mode enable (D)	<b>4D</b> , 6B		
RCK_HI*	Loads transient-level counter (D)	<b>1D</b> , 6A		
RCK_LOW*	Loads main-level counter (D)	<b>1D</b> , 6A		
RNG	CC-mode range select (D)	<b>7C</b>		2B

(A) = analog signal

(D) = digital signal

8C = signal origin

**Table 4-2. Signal-Name Descriptions**

Mnemonic	Function	Sheet 1	Sheet 2	Sheet 3
<b>CONTROL BOARD</b>				
+ S	Remote + sense (A) from rear-panel + S		<b>1C</b>	2C
- S	Remote - sense (A) from rear-panel - S		<b>1C</b>	2C
SA_EN*	Secondary μP SA enable (D) from TP301-1	<b>1C, 7D</b>		
SD	Secondary μP data bus (D)			
SDB	Secondary μP data bus, buffered (D)			
SKP	Skip self-test (D) from TP301-5	<b>1B, 6D</b>		
SLEW	Programming-voltage input to slew circuit (A)	<b>5B</b>	<b>4C, 5A</b>	
SLW1,SLW2,SLW3,SLW4	Slew-rate control signals (D)	<b>8C,8B, 8C,7C, 5C</b>		
SPCLR*	Secondary-circuit power-on clear (D)	<b>1B,7D,6D, 5D</b>	8D	<b>2D,2A</b>
SPROG	(not used)		2D	2C
SRX	Secondary-μP receiver (D)	<b>8D</b>		<b>5B</b>
START	Secondary-μP SA start signal (D)	<b>1B</b>		
STAT_EN	Enable status latch (D)	<b>4D, 3D</b>		
STB*	Enable chip-select decoder (D)	<b>7C, 2D</b>		
STOP	Secondary-μP SA stop signal (D)	<b>1B</b>		
STX	Secondary-μP transmitter (D)	<b>8D, 1B</b>		5A
S0, S1, S2	Chip-select-decoder input (D)	<b>7C, 2D</b>		
TEMP1	Power-board temperature (A)		5A	2C
TMONR	Temperature-monitor-comparator output (D)	6D	4A	
TOGGLE*	Toggle mode select (D)	6B	4A	
TRANS_EN	Transient-generator clear and enable (D)	<b>4D, 8B, 7B</b>		
	Secondary-μP SA start/stop (D)	<b>4D, 1B</b>		
TRIG	Trigger (D)	6A	8C	5B
TRIG_EN*	Main and transient DACs trigger enable (D)	<b>4D</b>	8D	
UNREG*	Unregulated-input status (D)	3D		2A
UXFER	Main and transient DACs transfer control (D)	<b>7C</b>	8D	
VMON	Voltage-monitor output (A) to rear-panel A2		<b>1C, 1C</b>	
VMON*	Input-voltage monitor signal (A)		3C, 6A	2B
	CR-mode middle-&-high-range DAC Ref (A)		5D	
VMONR	Voltage-monitor-comparator output (D)	6D	<b>4A</b>	
VREF	Voltage reference for DACs (A)		<b>6D, 8B, 5C</b>	
X	(not used)	3D		2A
-10V_REF	DAC reference for CV and CC modes (A)		<b>2B, 4D, 6A</b>	
+15V	To power board (A)			<b>5D, 2B</b>
-15V	To power board (A)			<b>5C, 2B</b>
+ 12V_REF	Ref for readback DAC & main DAC self-test (A)		<b>1A, 5B, 7B, 5D, 2B</b>	2B

(A) = analog signal

(D) = digital signal

8C = signal origin

**Table 4-2. Signal-Name Descriptions**

Mnemonic	Function	Sheet 1	Sheet 2	Sheet 3
	<b>POWER BOARD</b>			
ACLR*	Analog circuits clear (D)	1A, 7B		
BO*	Brown out input disable (D)	1B, 8B		
+BUS	+ input binding post			4A
- BUS	- input binding post			4A
CC_PROG	Programming voltage for CC mode (A)	8C		
CR*	CR_mode low range select (D)	8B		
CV_PROG	Programming voltage for CV mode (A)	8D		
E2	Electrical connection	8A, 6B		
E8	Electrical connection	6A, 7D		
E11	Electrical connection	5A, 8D		
IMON*	Input-current monitor signal (A)	8B	<b>6A</b>	
IMON2	Input-current monitor signal (A)		5A	8A
+IN	+input (A)	8A,7A,6D,1 D,1C		<b>4A</b>
- IN	- input (A)	8A, 7A, 1D		<b>4A</b>
+ IN Local	Same as + input (A)	1D		4A
+ OP	Overpower comparator input (A) (low = OP)	<b>3A</b> , 8A		
- OP	Overpower comparator input (A) (high = OP)	<b>4A</b> , 8A		
OP*	Overpower status (D)	<b>8A</b>		
+OV	Overvoltage comparator input (A) (low = OV)	<b>4D</b> , 8B		
OV*	Overvoltage status (D)	<b>8B</b>		
PROG	Programming input to power circuits (A)	<b>5D</b> , 1C	8D	8D
	Overvoltage reference (A)	7B		
RNG	CC-mode range select (D)	8C		
+S	Remote + sense (A) (from rear-panel +S)	1D		
- S	Remote - sense (A) (from rear-panel - S)	1D		
SPCLR*	Secondary-circuit power-on clear (D)	1B		
TEMP1	Power-board temperature (A)		8A	
TURNON	Power-on input disable (D)	<b>1B</b>	8C	8C
UNREG	Input to unregulated-input comparator (A)	8C, 6C, 7D, 4B	<b>8D</b>	
UNREG*	Unregulated-input status (D)	<b>8A</b>		
VOFF	Voltage off	3C	8C	
VMON*	Input-voltage monitor signal (A)	<b>8D</b>		
+12V_REF	Reference for overvoltage circuit (A)	1C		

(A) = analog signal

(D) = digital signal

**8C** = signal origin

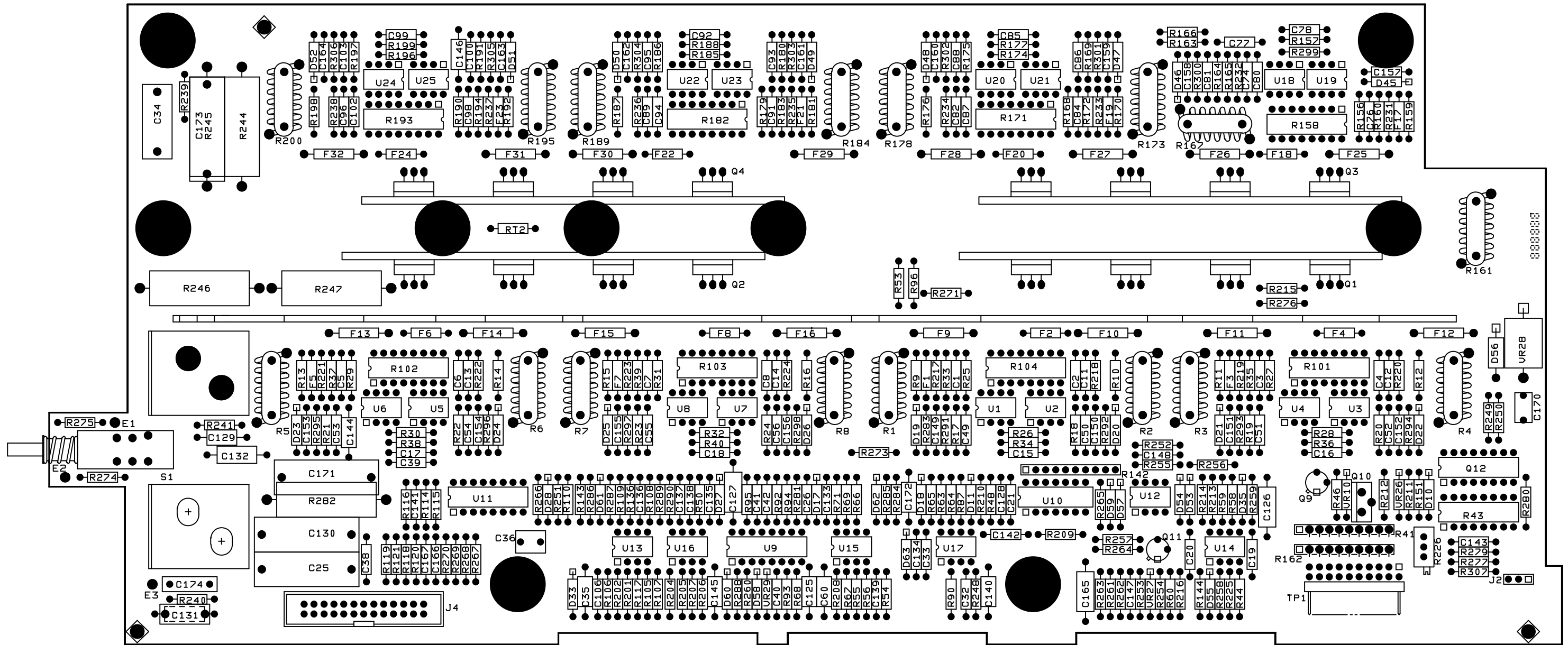

88888888

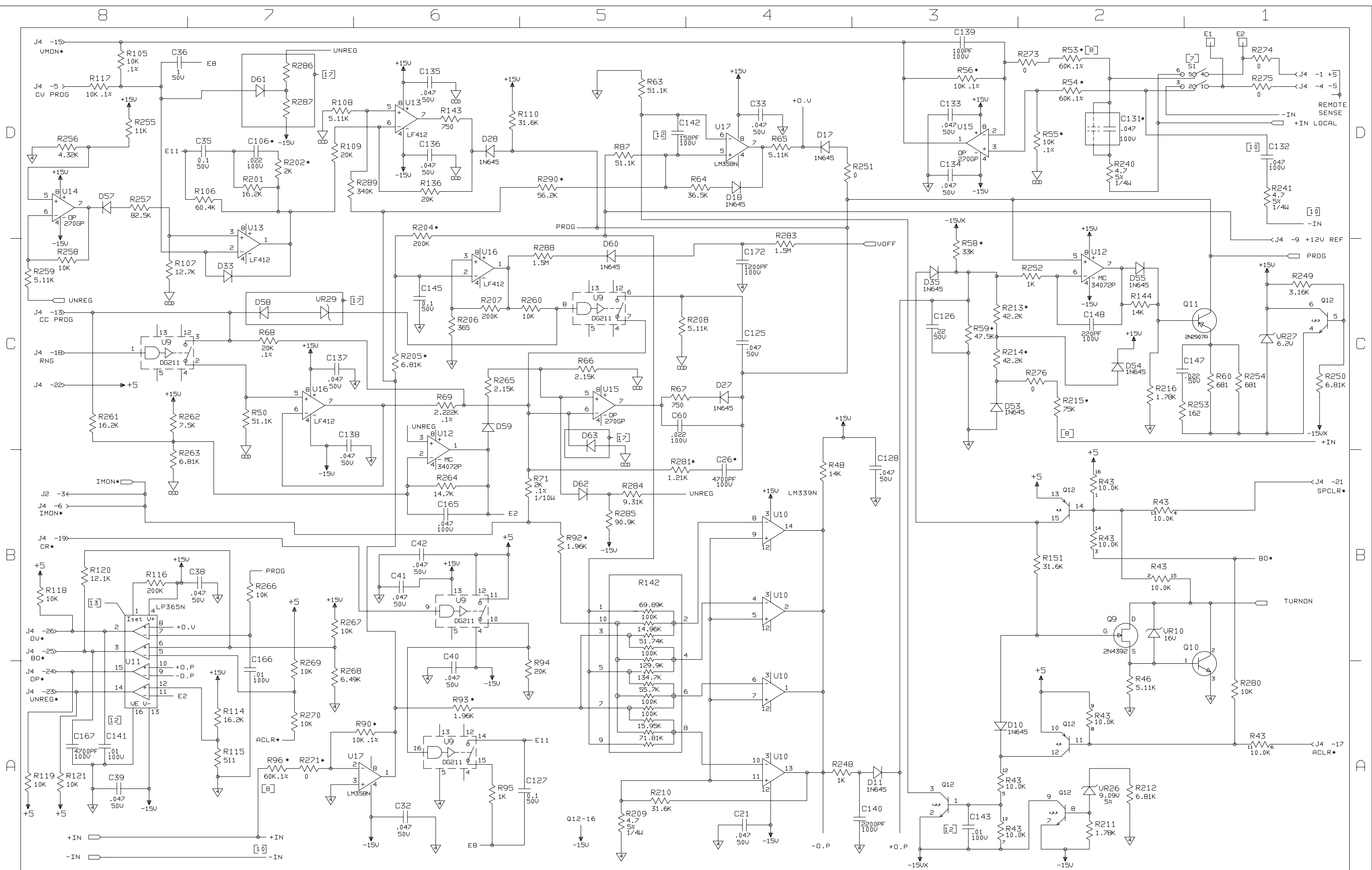

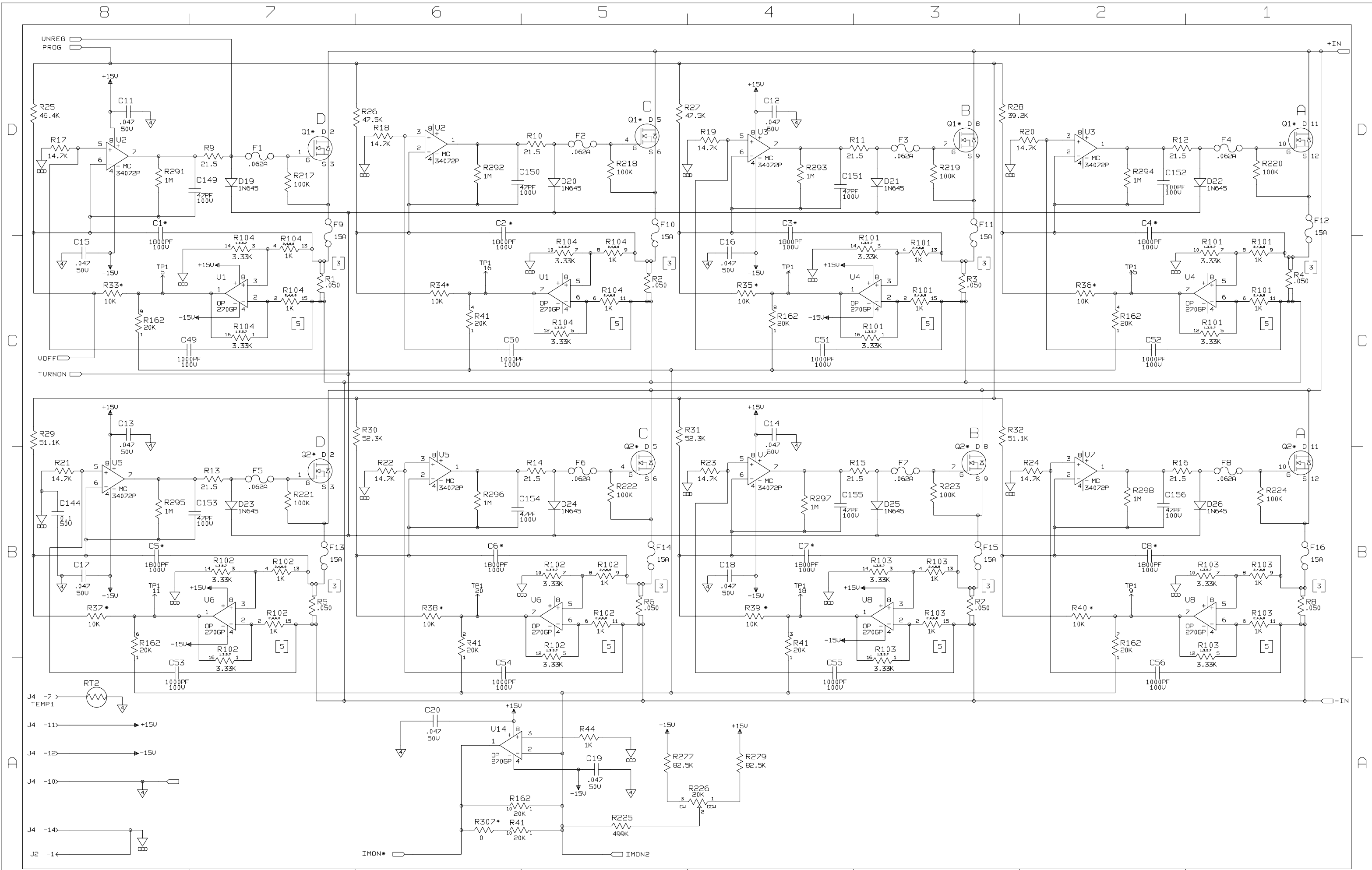

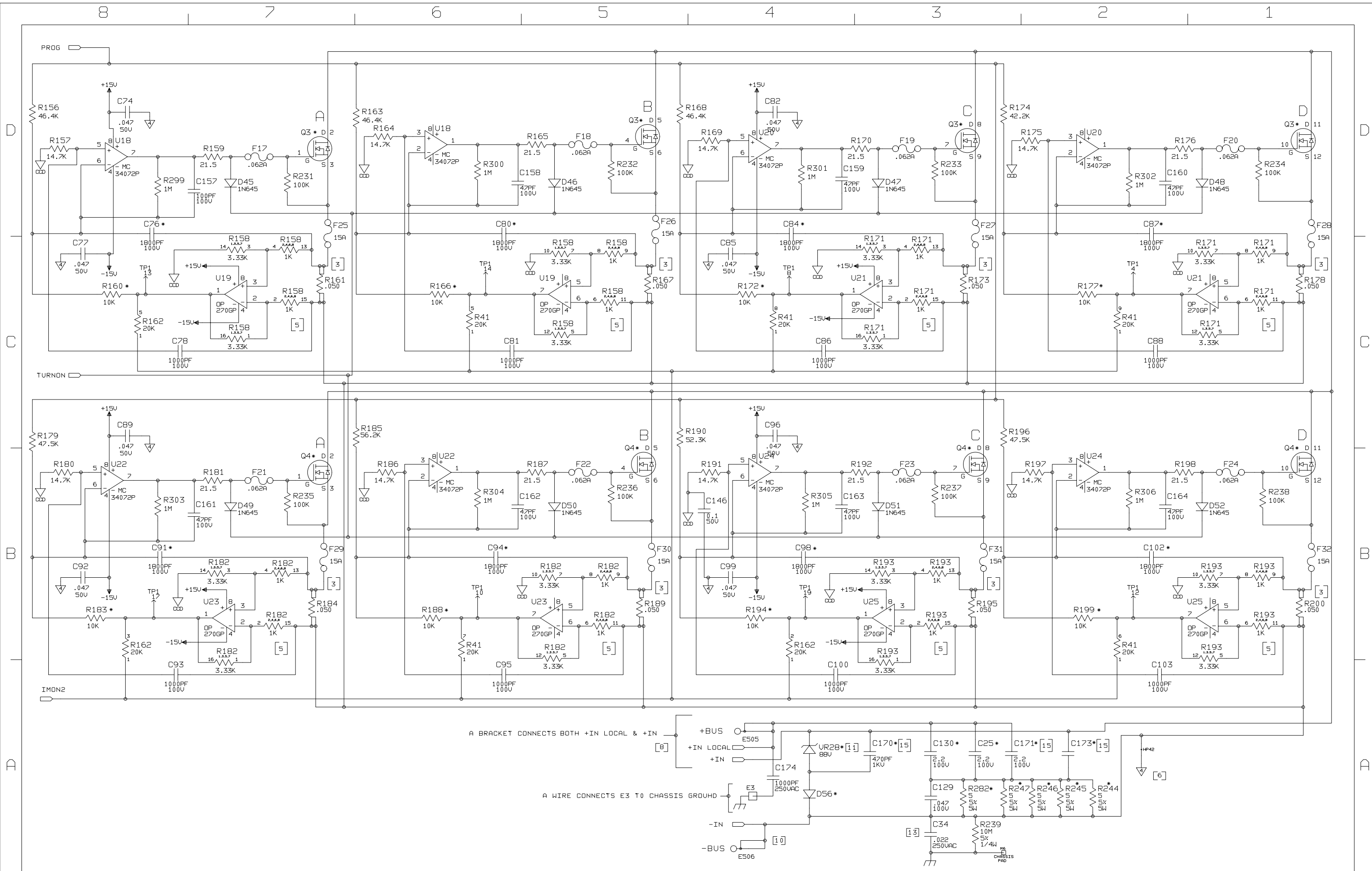

A BRACKET CONNECTS BOTH +IN LOCAL & +IN

A WIRE CONNECTS E3 TO CHASSIS GROUND





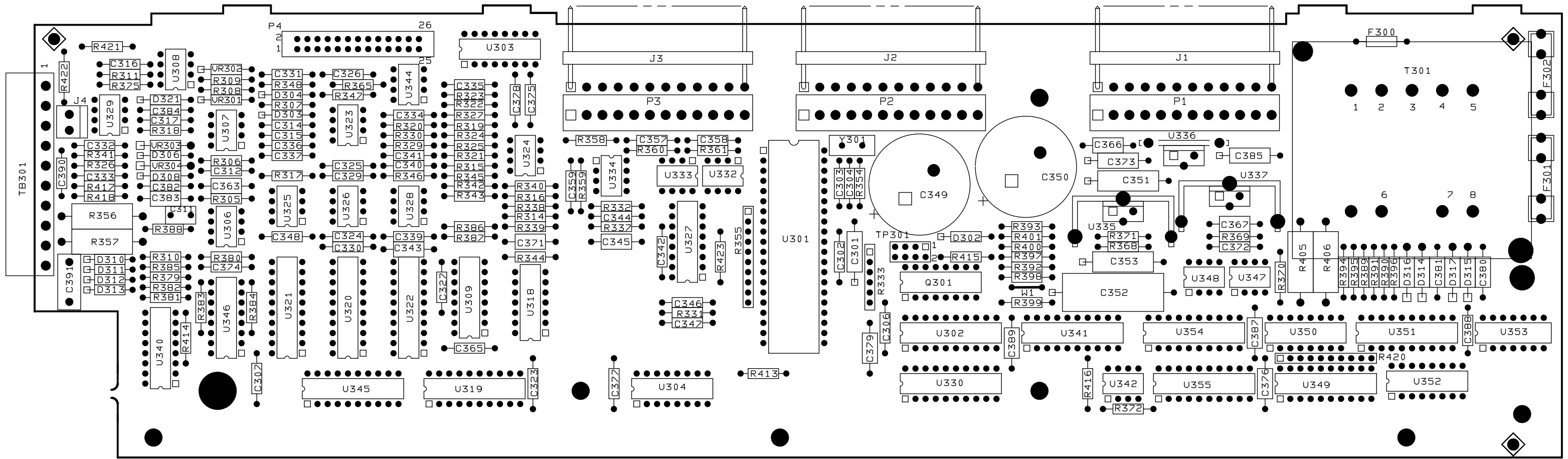

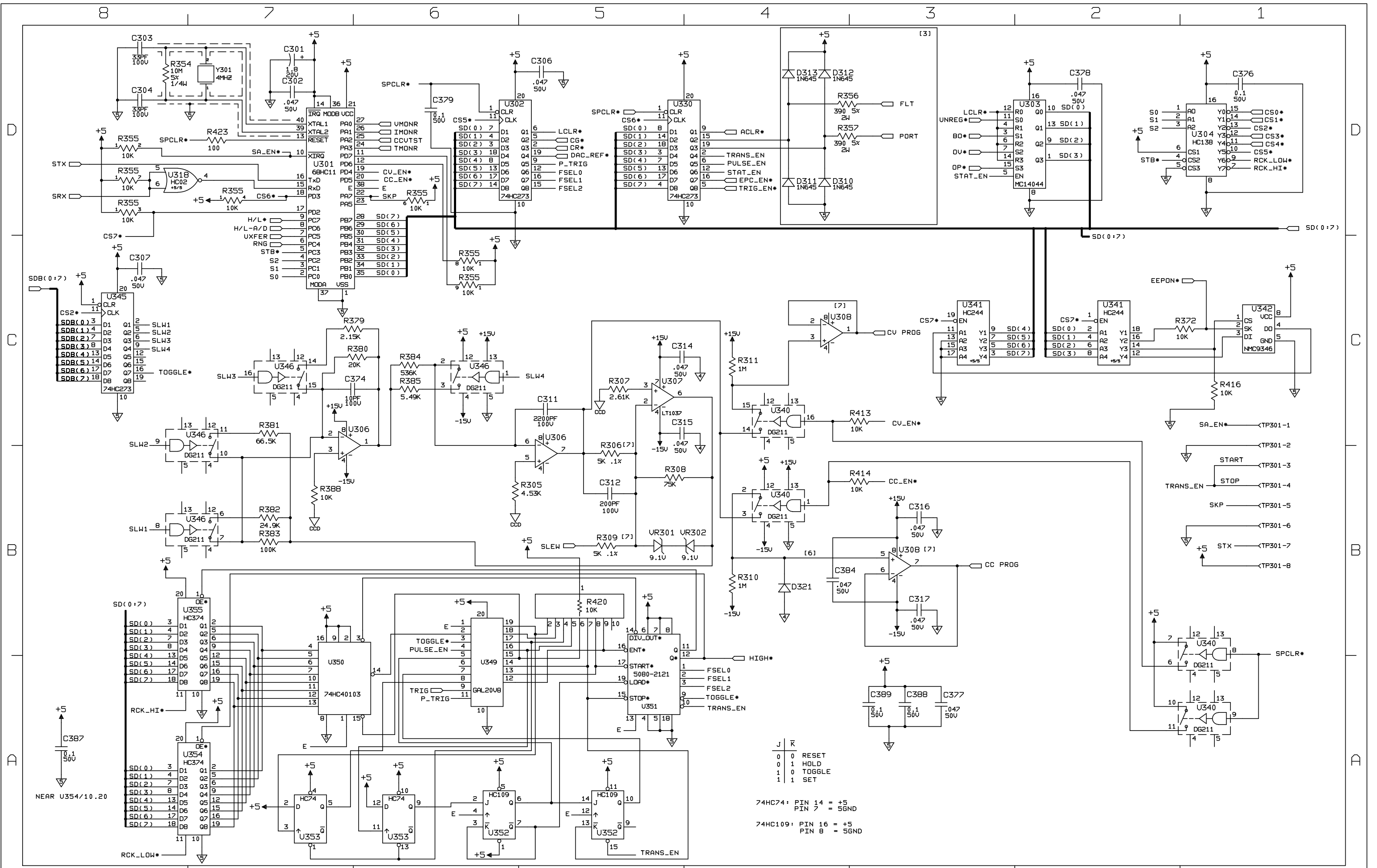

J	K	Output
0	0	RESET
0	1	HOLD
1	0	TOGGLE
1	1	SET

74HC74: PIN 14 = +5  
PIN 7 = SGND

74HC109: PIN 16 = +5  
PIN 8 = SGND

\* C371 - 4700PF ON 60503

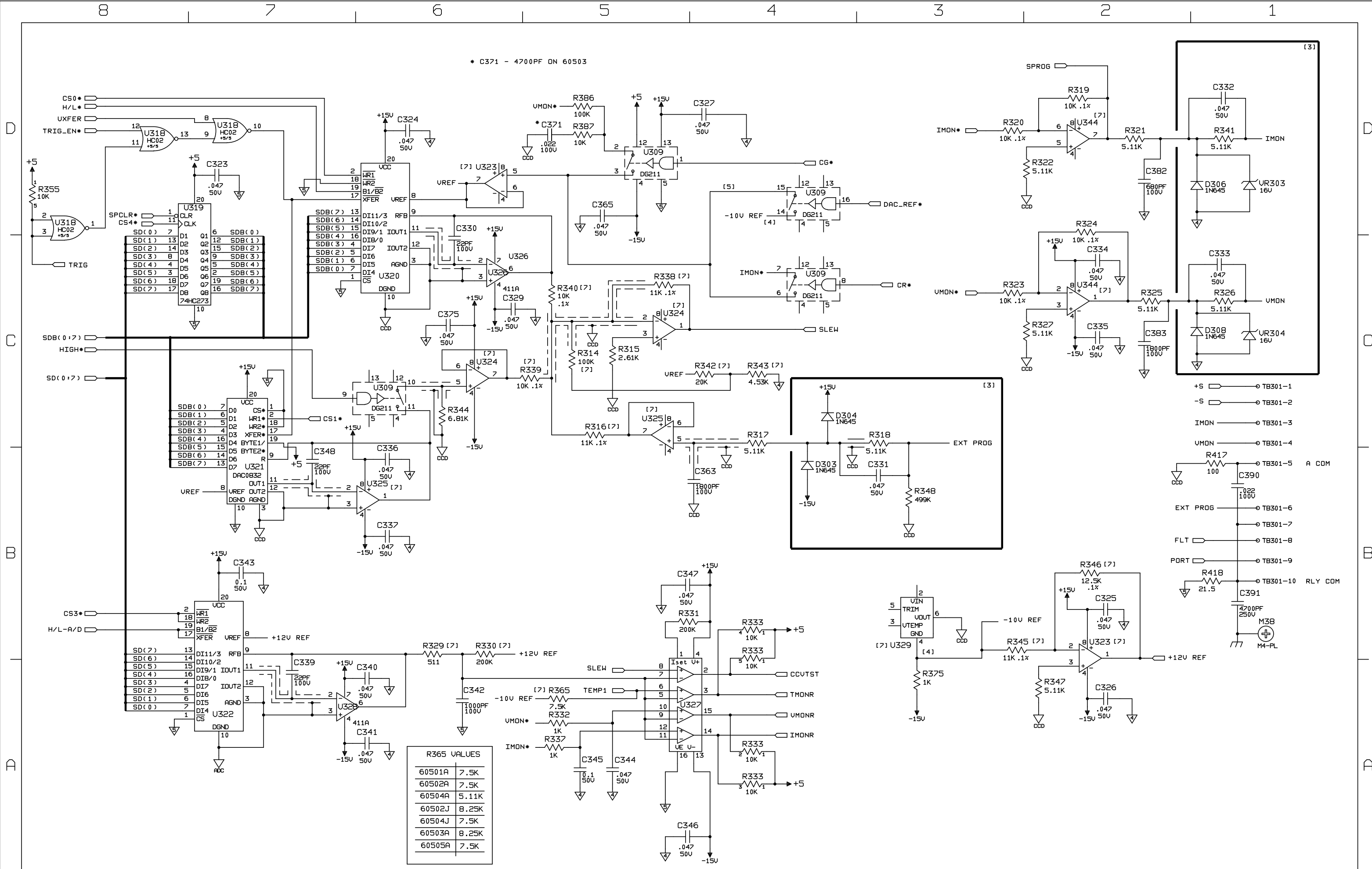

R365 VALUES	
60501A	7.5K
60502A	7.5K
60504A	5.11K
60502J	8.25K
60504J	7.5K
60503A	8.25K
60505A	7.5K

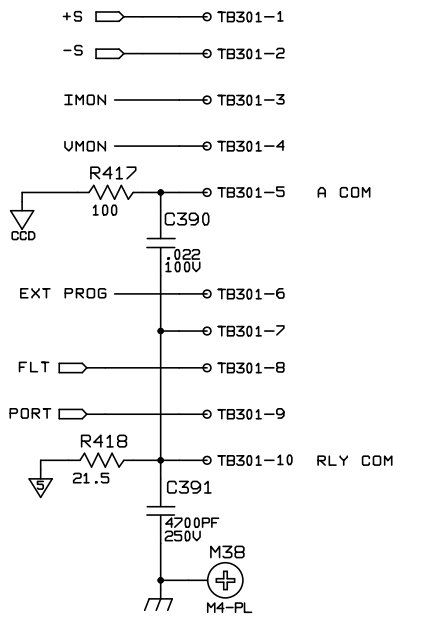

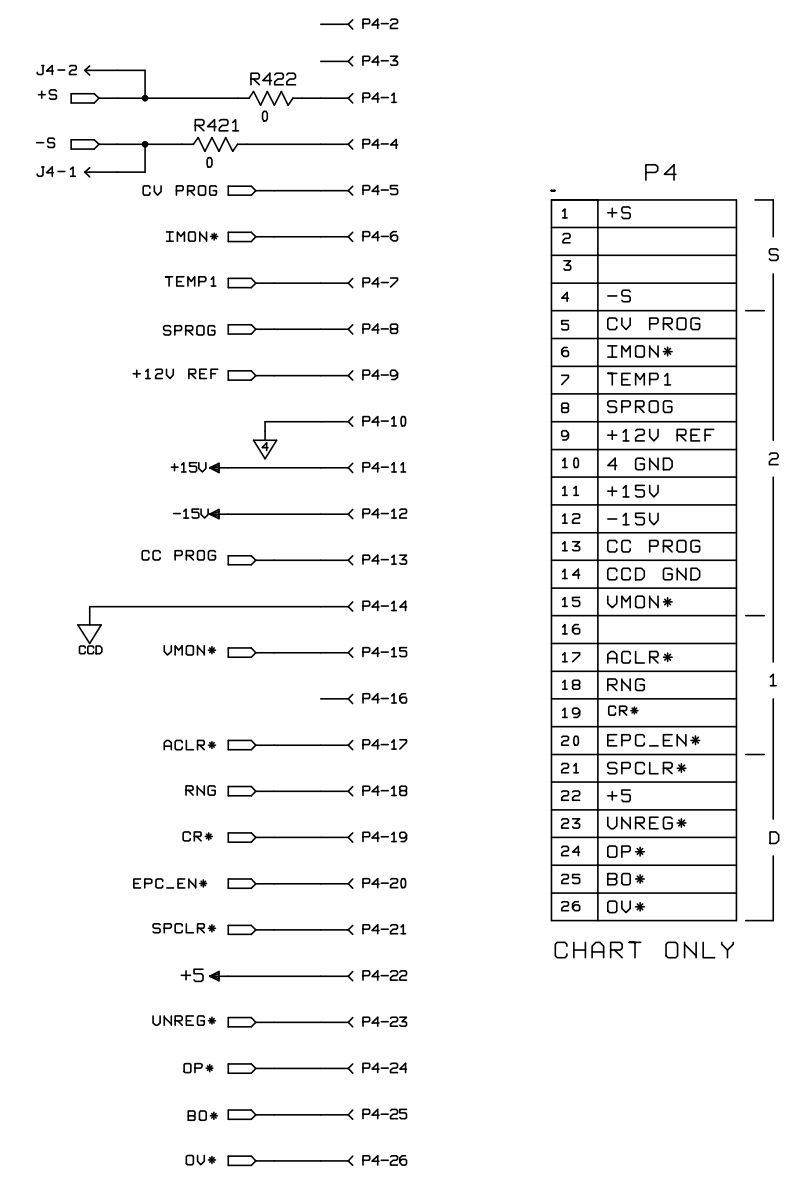
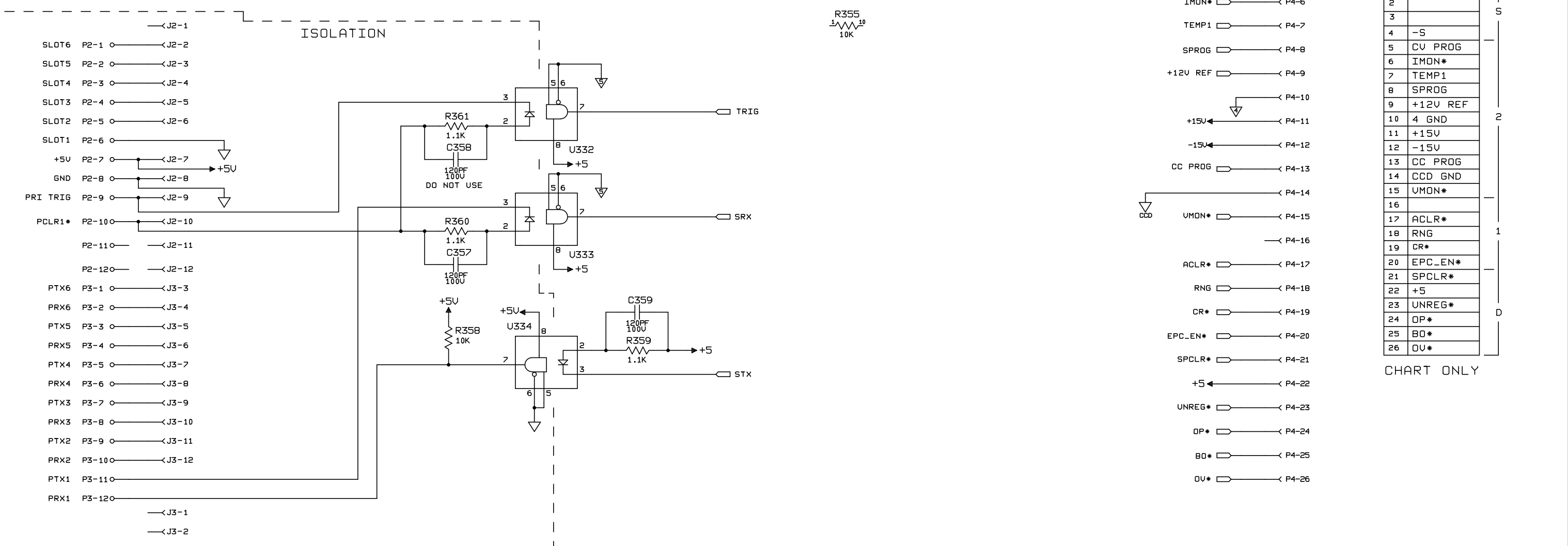
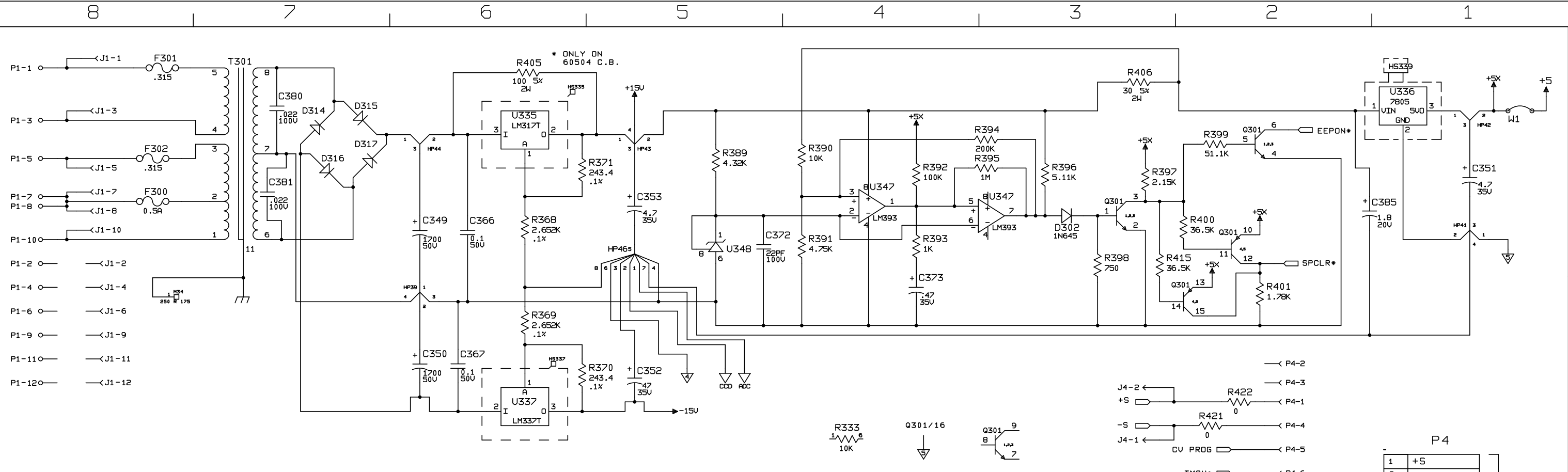

P4	
1	+S
2	
3	
4	-S
5	CV PROG
6	IMON*
7	TEMP1
8	SPROG
9	+12V REF
10	4 GND
11	+15V
12	-15V
13	CC PROG
14	CCD GND
15	UMON*
16	
17	ACLR*
18	RNG
19	CR*
20	EPC_EN*
21	SPCLR*
22	+5
23	UNREG*
24	OP*
25	BO*
26	OU*

CHART ONLY