

OPERATING AND SERVICE MANUAL

# 6034A SYSTEM DC POWER SUPPLY

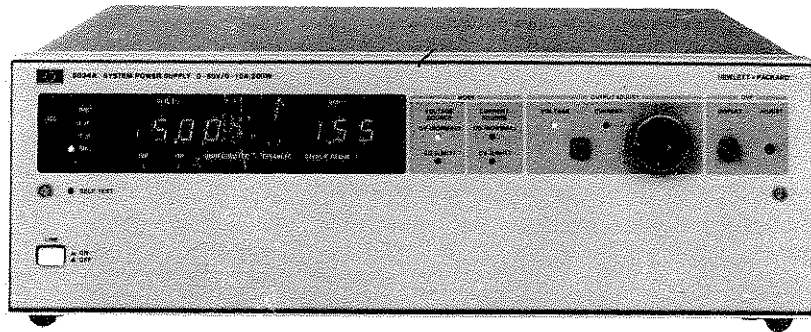

**HEWLETT  
PACKARD**





**HEWLETT  
PACKARD**

### **CERTIFICATION**

*Hewlett-Packard Company certifies that this product met its published specifications at the time of shipment from the factory. Hewlett-Packard further certifies that its calibration measurements are traceable to the United States National Bureau of Standards, to the extent allowed by the Bureau's calibration facility, and to the calibration facilities of other International Standards Organization members.*

### **WARRANTY**

This Hewlett-Packard instrument product is warranted against defects in material and workmanship for a period of one year from date of shipment. During the warranty period, Hewlett-Packard Company will, at its option, either repair or replace products which prove to be defective.

For warranty service or repair, this product must be returned to a service facility designated by HP. Buyer shall prepay shipping charges to HP and HP shall pay shipping charges to return the product to Buyer. However, Buyer shall pay all shipping charges, duties, and taxes for products returned to HP from another country.

HP warrants that its software and firmware designated by HP for use with an instrument will execute its programming instructions when properly installed on that instrument. HP does not warrant that the operation of the instrument, or software, or firmware will be uninterrupted or error free.

### **LIMITATION OF WARRANTY**

The foregoing warranty shall not apply to defects resulting from improper or inadequate maintenance by Buyer, Buyer-supplied software or interfacing, unauthorized modification or misuse, operation outside of the environmental specifications for the product, or improper site preparation or maintenance.

NO OTHER WARRANTY IS EXPRESSED OR IMPLIED. HP SPECIFICALLY DISCLAIMS THE IMPLIED WARRANTIES OF MERCHANTABILITY AND FITNESS FOR A PARTICULAR PURPOSE.

### **EXCLUSIVE REMEDIES**

THE REMEDIES PROVIDED HEREIN ARE BUYER'S SOLE AND EXCLUSIVE REMEDIES. HP SHALL NOT BE LIABLE FOR ANY DIRECT, INDIRECT, SPECIAL, INCIDENTAL, OR CONSEQUENTIAL DAMAGES, WHETHER BASED ON CONTRACT, TORT, OR ANY OTHER LEGAL THEORY.

### **ASSISTANCE**

*Product maintenance agreements and other customer assistance agreements are available for Hewlett-Packard products.*

*For any assistance, contact your nearest Hewlett-Packard Sales and Service Office. Addresses are provided at the back of this manual.*





**HEWLETT  
PACKARD**

**AUTORANGING  
DC POWER SUPPLY  
MODEL 6034A**

**OPERATING AND SERVICE MANUAL FOR  
INSTRUMENTS WITH SERIAL NUMBERS  
2231A-00831 AND ABOVE**

For instruments with Serial Numbers below 2231A-00831,  
check Appendix C. For instruments with Serial Numbers above  
2231A-00831, a change page may be included.

## SAFETY SUMMARY

The following general safety precautions must be observed during all phases of operation, service, and repair of this instrument. Failure to comply with these precautions or with specific warnings elsewhere in this manual violates safety standards of design, manufacture, and intended use of the instrument. Hewlett-Packard Company assumes no liability for the customer's failure to comply with these requirements.

### BEFORE APPLYING POWER.

Verify that the product is set to match the available line voltage and the correct fuse is installed.

### GROUND THE INSTRUMENT.

This product is a Safety Class 1 instrument (provided with a protective earth terminal). To minimize shock hazard, the instrument chassis and cabinet must be connected to an electrical ground. The instrument must be connected to the ac power supply mains through a three-conductor power cable, with the third wire firmly connected to an electrical ground (safety ground) at the power outlet. For instruments designed to be hard-wired to the ac power lines (supply mains), connect the protective earth terminal to a protective conductor before any other connection is made. Any interruption of the protective (grounding) conductor or disconnection of the protective earth terminal will cause a potential shock hazard that could result in personal injury. If the instrument is to be energized via an external autotransformer for voltage reduction, be certain that the autotransformer common terminal is connected to the neutral (earthed pole) of the ac power lines (supply mains).

### INPUT POWER MUST BE SWITCH CONNECTED.

For instruments without a built-in line switch, the input power lines must contain a switch or another adequate means for disconnecting the instrument from the ac power lines (supply mains).

### DO NOT OPERATE IN AN EXPLOSIVE ATMOSPHERE.

Do not operate the instrument in the presence of flammable gases or fumes.

### KEEP AWAY FROM LIVE CIRCUITS.

Operating personnel must not remove instrument covers. Component replacement and internal adjustments must be made by qualified service personnel. Do not replace components with power cable connected. Under certain conditions, dangerous voltages may exist even with the power cable removed. To avoid injuries, always disconnect power, discharge circuits and remove external voltage sources before touching components.

### DO NOT SERVICE OR ADJUST ALONE.

Do not attempt internal service or adjustment unless another person, capable of rendering first aid and resuscitation, is present.

### DO NOT EXCEED INPUT RATINGS.

This instrument may be equipped with a line filter to reduce electromagnetic interference and must be connected to a properly grounded receptacle to minimize electric shock hazard. Operation at line voltages or frequencies in excess of those stated on the data plate may cause leakage currents in excess of 5.0 mA peak.

### SAFETY SYMBOLS.



Instruction manual symbol: the product will be marked with this symbol when it is necessary for the user to refer to the instruction manual (refer to Table of Contents).



Indicates hazardous voltages.



or



Indicate earth (ground) terminal.



The WARNING sign denotes a hazard. It calls attention to a procedure, practice, or the like, which, if not correctly performed or adhered to, could result in personal injury. Do not proceed beyond a WARNING sign until the indicated conditions are fully understood and met.



The CAUTION sign denotes a hazard. It calls attention to an operating procedure, or the like, which, if not correctly performed or adhered to, could result in damage to or destruction of part or all of the product. Do not proceed beyond a CAUTION sign until the indicated conditions are fully understood and met.

### DO NOT SUBSTITUTE PARTS OR MODIFY INSTRUMENT.

Because of the danger of introducing additional hazards, do not install substitute parts or perform any unauthorized modification to the instrument. Return the instrument to a Hewlett-Packard Sales and Service Office for service and repair to ensure that safety features are maintained.

*Instruments which appear damaged or defective should be made inoperative and secured against unintended operation until they can be repaired by qualified service personnel.*

# CONTENTS

## Section I GENERAL INFORMATION

1-1	Introduction.....	1-1
1-3	Specifications.....	1-1
1-5	Safety Considerations.....	1-1
1-7	Instrument and Manual Identification.....	1-1
1-10	Description.....	1-1
1-16	Options.....	1-1
1-18	Accessories.....	1-2
1-20	HP-IB Interconnection Cables and Connectors.....	1-2
1-23	Ordering Additional Manuals.....	1-2
1-25	Related Documents.....	1-2
1-27	HP-IB Compatibility.....	1-3

## Section II INSTALLATION

2-1	Introduction.....	2-1
2-3	Initial Inspection.....	2-1
2-5	Mechanical Check.....	2-1
2-7	Electrical Check.....	2-1
2-9	Preparation for Use.....	2-1
2-11	Location and Cooling.....	2-2
2-13	Outline Diagram.....	2-2
2-15	Bench Operation.....	2-2
2-17	Rack Mounting.....	2-2
2-19	Input Power Requirements.....	2-2
2-21	Power Cable.....	2-2
2-25	Line Voltage Option Conversion.....	2-2
2-27	Repackaging for Shipment.....	2-4

## Section III OPERATING INSTRUCTIONS

3-1	Introduction.....	3-1
3-3	Controls and Indicators.....	3-1
3-5	Output Range for an Autoranging Power Supply.....	3-1
3-10	Overrange.....	3-4
3-13	Turn-On Checkout Procedure.....	3-4
3-16	Initial Setup and Interconnections.....	3-5
3-17	Connecting the Load.....	3-5

3-24	Overvoltage Protection (OVP).....	3-6
3-26	Local Adjustment.....	3-6
3-27	Local OVP Reset.....	3-6
3-28	Remote Adjustment.....	3-6
3-29	Remote OVP Reset.....	3-6
3-30	Remote Voltage Sensing.....	3-6
3-35	Auto-Parallel Operation.....	3-7
3-37	Setting Output Voltage and Current.....	3-8
3-38	Overvoltage Protection in Auto-Parallel.....	3-8
3-39	Auto-Parallel with Remote Voltage Sensing.....	3-8
3-40	Auto-Series Operation.....	3-8
3-44	Setting Output Voltage and Current.....	3-9
3-45	Resistor Values.....	3-9
3-50	Overvoltage Protection in Auto-Series.....	3-10
3-51	Auto-Series with Remote Voltage Sensing.....	3-10
3-52	Auto-Tracking Operation.....	3-10
3-55	Resistor Values.....	3-11
3-62	Setting the Current Controls.....	3-11
3-63	Overvoltage Protection in Auto-Tracking.....	3-11
3-64	Auto-Tracking with Remote Voltage Sensing.....	3-11
3-65	HP-IB.....	3-11
3-70	Current-Monitor Output Signal.....	3-12
3-72	Protective Circuits.....	3-12
3-74	Local Operation.....	3-12
3-76	Constant Voltage Operation.....	3-12
3-78	Constant Current Operation.....	3-12
3-80	Return to Local.....	3-12
3-82	HP-IB Operation.....	3-13
3-83	Interface Functions.....	3-13
3-85	Multiline Message Control Functions.....	3-13
3-86	Service Request.....	3-13
3-89	Serial Poll.....	3-15
3-94	Parallel Poll.....	3-15
3-97	Remote Local.....	3-15
3-98	Device Clear.....	3-15
3-99	Device Trigger.....	3-15
3-100	HP-IB Address Selection.....	3-15
3-103	Programming Syntax.....	3-16
3-105	Initial Conditions.....	3-16
3-106	Mode.....	3-16
3-108	Delay.....	3-16
3-110	Interrupt Mask.....	3-17
3-111	Potential (Voltage).....	3-17
3-115	Current.....	3-17
3-117	Soft Voltage Limit (Upper Value).....	3-18

## CONTENTS (cont.)

3-122	Soft Current Limit (Upper Value).....	3-18		4-118	Down Programmer.....	4-14
3-124	Set Reset.....	3-18		4-122	Overvoltage Protection Circuit.....	4-14
3-128	Go.....	3-18		4-125	AC Dropout Detector.....	4-14
3-129	Trigger.....	3-18		4-127	Bias Voltage Detector.....	4-14
				4-130	Over Temperature Detector.....	4-14

### Section IV PRINCIPLES OF OPERATION

4-1	Introduction.....	4-1
4-4	HP-IB Circuits.....	4-1
4-7	Transceivers and Bus Functions.....	4-1
4-16	Serial Poll/Receive Handshake Monitor.....	4-2
4-19	Listen/T.E.1/Talk Monitor.....	4-2
4-21	Device Trigger Monitor.....	4-2
4-23	Device Clear Monitor.....	4-2
4-25	Transmit Handshake Monitor.....	4-2
4-27	HP-IB Interrupt Monitor and Pulse Generator.....	4-2
4-30	Load/Shift Control.....	4-2
4-33	Receive Handshake Control.....	4-2
4-35	Transmit Ready Control.....	4-4
4-37	Data/Status Multiplexers.....	4-5
4-40	Data Shifter/Output Buffer.....	4-5
4-44	Isolation Components.....	4-5
4-46	Microcomputer.....	4-5
4-48	Memory Circuits.....	4-5
4-51	Microprocessor Interrupt.....	4-5
4-59	CRU Clock Generator.....	4-8
4-61	I/O Address Decoding.....	4-8
4-63	DAC Circuits.....	4-8
4-65	Front-Panel Assembly.....	4-8
4-67	I/O Inputs.....	4-8
4-69	I/O Outputs.....	4-8
4-71	Constant Current Reference Circuit.....	4-8
4-77	Constant Voltage Reference Circuit.....	4-9
4-79	Voltmeter Range Circuit.....	4-9
4-81	Rotary Pulse Generator Decoders.....	4-10
4-84	Voltmeter and Current Meter.....	4-10
4-86	Power Mesh and Control Board.....	4-10
4-91	Input AC Circuits.....	4-10
4-93	DC to DC Converter.....	4-11
4-99	Constant Voltage (CV) Control Circuit.....	4-13
4-103	Constant Current (CC) Control Circuit.....	4-13
4-105	Control Voltage.....	4-13
4-108	Pulse Width Modulator.....	4-13
4-111	PWM Fast Turn Off.....	4-13
4-113	Primary Current (Ip) Limit.....	4-13
4-116	Bleed Circuit.....	4-14

### Section V MAINTENANCE

5-1	Introduction.....	5-1
5-3	Test Equipment Required.....	5-1
5-6	Performance Test.....	5-1
5-7	Measurement Techniques.....	5-1
5-9	Selecting a Load Resistor.....	5-1
5-11	Connecting a Current-Monitoring Resistor.....	5-1
5-12	Constant Voltage Tests.....	5-1
5-15	Rated Voltage and Voltmeter Accuracy.....	5-3
5-16	Load Effect (Load Regulation).....	5-3
5-18	Source Effect (Line Regulation).....	5-3
5-20	PARD (Ripple and Noise).....	5-4
5-22	Ripple Measurement Techniques.....	5-4
5-25	Ripple Measurement Procedure.....	5-5
5-26	Noise Spike Measurement Techniques.....	5-5
5-29	Noise Spike Measurement Procedure.....	5-5
5-31	Load Transient Recovery Time.....	5-6
5-32	Measurement Techniques.....	5-6
5-34	Measurement Procedure.....	5-6
5-35	Temperature Coefficient.....	5-7
5-39	Drift (Stability).....	5-7
5-42	Constant-Current Tests.....	5-7
5-44	Current Output and Current Meter.....	5-8
5-45	Load Effect (Load Regulation).....	5-8
5-47	Source Effect (Line Regulation).....	5-8
5-49	PARD (Ripple and Noise).....	5-9
5-53	Troubleshooting.....	5-9
5-54	Introduction.....	5-9
5-57	Initial Procedures.....	5-10
5-59	Optional Service Package.....	5-10
5-61	Self Test and Test Mode.....	5-10
5-68	Turn-On Self Test.....	5-13
5-69	Test Mode Self Tests.....	5-13
5-74	Test Mode Signature Analysis.....	5-15



## CONTENTS (cont.)

5-76	LED Test Mode.....	5-15
5-78	Troubleshooting Trees.....	5-15
5-81	Troubleshooting Test Setup.....	5-16
5-82	Signature Analysis.....	5-16
5-92	Free-Run Mode Procedure.....	5-18
5-96	Signature Analysis Procedure.....	5-18
5-99	Input and Output Ports.....	5-21
5-101	Repair and Replacement.....	5-66
5-103	Front-Panel Assembly.....	5-66
5-105	Control Board.....	5-66
5-107	Rotary Pulse Generator (RPG).....	5-66
5-109	Power Mesh Thermal Resistors.....	5-67
5-111	Current-Monitor Resistor Heatsink.....	5-67
5-113	A5 Regulator.....	5-67
5-116	HP-IB Bias Power Supply Repair.....	5-67
5-118	Replacement Parts.....	5-68
5-121	Calibration.....	5-68
5-123	Initial Setup.....	5-68
5-124	Remote OVP Calibration.....	5-68
5-125	I <sub>p</sub> Limit Calibration.....	5-68
5-127	Regulation Adjustment.....	5-69
5-128	Constant Voltage Circuit Calibration.....	5-69
5-130	Constant Current Circuit Calibration.....	5-69
5-132	Front-Panel Voltmeter Calibration.....	5-69
5-133	Front-Panel Current Meter Calibration.....	5-70
5-134	Remote Current Meter Calibration.....	5-70
5-135	Remote Voltmeter Zero Calibration.....	5-70
5-136	Remote Voltmeter Full Scale Calibration.....	5-70

### Section VI REPLACEABLE PARTS

6-1	Introduction.....	6-1
6-4	Ordering Information.....	6-1

### Section VII COMPONENT LOCATION ILLUSTRATIONS AND CIRCUIT DIAGRAMS

#### Appendix A 100 VAC INPUT POWER OPTION 100

#### Appendix B LOGIC SYMBOLOLOGY

#### Appendix C MANUAL BACKDATING CHANGES



IEEE Std 488-1978 Digital Interface for Programmable Instrumentation, corrected edition July 25, 1980, or later, available from:

IEEE  
345 East 47th Street  
New York, NY 10017

### 1-27 HP-IB COMPATIBILITY

1-28 The 6034A implements the following HP-IB interface

functions:

- SH1 (Source Handshake)
- AH1 (Acceptor Handshake)
- T1 (Talker)
- L1 (Listener)
- SR1 (Service Request)
- RL1 (Remote Local)
- PP1 (Parallel Poll)
- DC1 (Device Clear)
- DT1 (Device Trigger)

Table 1-1. Specifications and Supplemental Characteristics

All performance specifications are measured at rear-panel terminals with a resistive load, ambient temperature  $25^{\circ}\text{C} \pm 5^{\circ}\text{C}$ .

**DC Output:** Voltage and current can be programmed via HP-IB or front-panel control over the following ranges:

**Voltage:** 0 to 60 V      **Current:** 0 to 10 A

See graph below for maximum output power. (This power is available at load with up to 0.5 V drop in each load lead.)

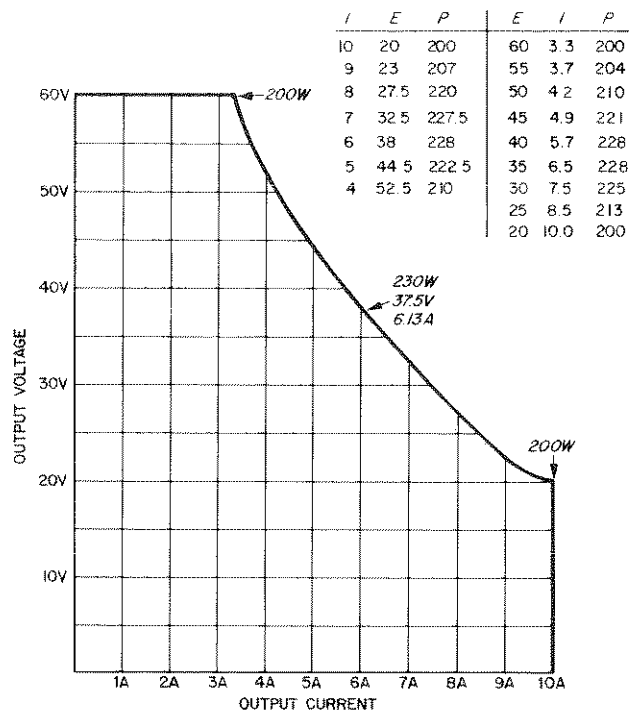

**Load Effect (Load Regulation):** For load change equal to the maximum available current rating of the supply at the set voltage (CV), or maximum available voltage rating at the set current (CC).

**Voltage:**  $\pm 0.01\% \pm 3 \text{ mV}$       **Current:**  $0.01\% + 3 \text{ mA}$

**Source Effect:**

**Voltage:**  $0.01\% + 2 \text{ mV}$       **Current:**  $0.01\% + 2 \text{ mA}$

**PARD:** (Ripple and Noise) RMS/p-p, 20 Hz to 20 MHz:

**Voltage:** 3 mV/30 mV      **Current:** 5 mA RMS

**Temperature Coefficient:**  $\Delta/\text{C}^{\circ}$  after 30-minute warmup:

**Voltage:**  $\pm 0.009\% \pm 0.7 \text{ mV}$

**Current:**  $\pm 0.009\% \pm 0.8 \text{ mA}$

**Drift (Stability):** Change in output over an 8-hour interval under constant line, load, and ambient temperature after 30-minute warmup.

**Voltage:**  $\pm 0.03\% \pm 3 \text{ mV}$       **Current:**  $\pm 0.03\% \pm 3 \text{ mA}$

**Load Transient Recovery Time:** Less than 1 ms is required for output voltage recovery (in constant voltage operation) to within 75 mV of the nominal output following a change in output current from 90% to 100% or 100% to 90% of maximum current.

**Programming Resolution:**

**Voltage:** 15 mV      **Current:** 2.5 mA

**Programming Accuracy ( $25 \pm 5^{\circ}\text{C}$ ):**

Constant Voltage:  $\pm 0.07\% \pm 28 \text{ mV}$

Constant Current:  $\pm 0.085\% \pm 12.5 \text{ mA}$

**Output Impedance (Typical):** 0.1 m $\Omega$  @ dc, less than 1 $\Omega$  for all frequencies below 1 MHz. See graph:

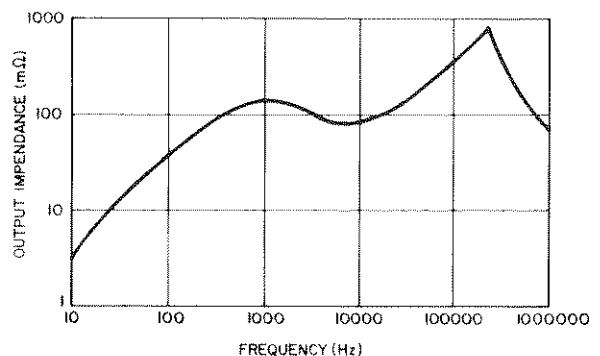

Table 1-1. Specifications and Supplemental Characteristics (cont.)

**Programmable Time Delay:**

Range: 0-65,535 ms  
 Resolution: 1 ms  
 Accuracy:  $\pm 5\%$  typical

**Programming Response Time:** Maximum time for output voltage to change from 0 V to 60 V or 60 V to 2 V and settle within a 60 mV band (0.1% of maximum rated output):

Band: 60 mV(\*) 15 mV(\*\*)

Up:	Full Load (18 $\Omega$ )	200 ms	225 ms
	No Load	200 ms	225 ms
Down:	Full Load (18 $\Omega$ )	300 ms	450 ms
	No Load	600 ms	750 ms

\*Max, \*\* Typical

Typical response time for excursions other than full-scale can be calculated as follows:

**Up Programming:** On graph, read time for change in output voltage.

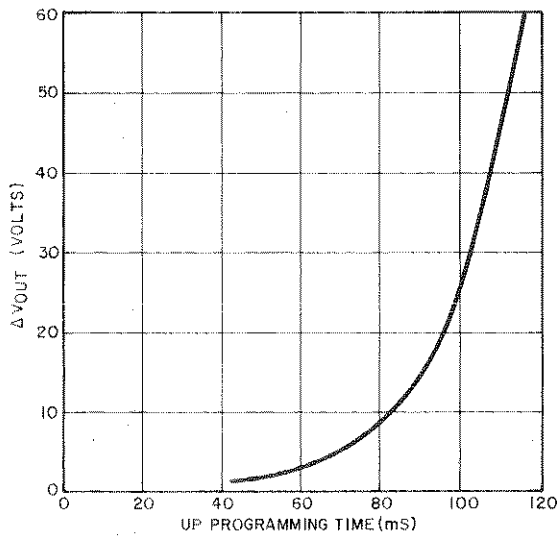

**Down Programming:** On graph, read difference in time between initial-output-voltage point and final-output-voltage point; add settling time of 125 ms if final voltage  $\geq 2$  V, or 500 ms if final voltage  $< 2$  V, to settle within 60 V band.

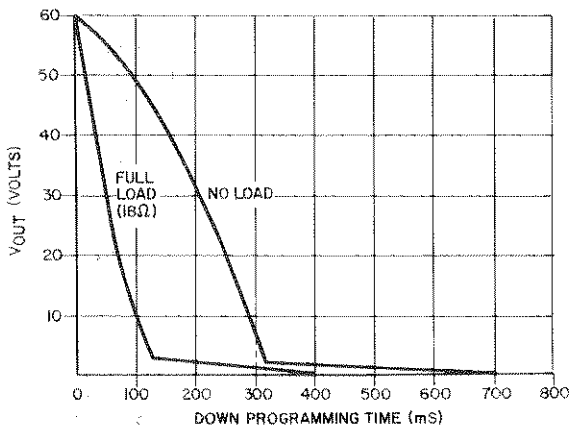

**Front Panel Meters:**

Output Voltage: Low Range:  $\pm 20.00$  V  
 High Range:  $\pm 200.0$  V  
 Range Switch Points: Up: above 19.99 V  $\pm 0$  V  
 Down: below 17.5 V typical  
 Resolution: Low Range: 10 mV  
 High Range: 100 mV  
 Accuracy: Low Range:  $\pm 20$  mV  $\pm 0.07\%$   
 High Range:  $\pm 200$  mV  $\pm 0.09\%$   
 Temperature Coefficient:  $\pm 0.01\%/^{\circ}\text{C}$

**OVP Setting:** (with reference to A2 terminal, not -S)  
 Range: 200.0 V  
 Resolution: 100 mV  
 Accuracy: 0.5% + 150 mV (at 0.0A load current)

**Output Current:**  
 Range:  $\pm 19.99$  A  
 Resolution: 10 mA  
 Accuracy:  $\pm 17$  mA  $\pm 0.1\%$   
 Temperature Coefficient:  $\pm 0.01\%/^{\circ}\text{C}$   $\pm 0.7$  mA/ $^{\circ}\text{C}$

**Readback:**

Output Voltage:  
 Range: 0-60 V  
 Resolution: 15 mV  
 Accuracy:  $\pm 0.08\%$   $\pm 35$  mV  
 Temperature Coefficient:  $\pm 0.07\%/^{\circ}\text{C}$   $\pm 0.35$  mV/ $^{\circ}\text{C}$

Output Current:  
 Range: 0-10 A  
 Resolution: 2.5 mA  
 Accuracy:  $\pm 0.125\%$   $\pm 8.5$  mA  
 Temperature Coefficient:  $\pm 0.007\%/^{\circ}\text{C}$   $\pm 0.35$  mV/ $^{\circ}\text{C}$   
 Settling Time:  $< 200$  ms

**Overvoltage Protection:** The lower of the two OVP trip points will dominate.

**Local OVP Adjustment:**

Range: 1.7 V to 64.5 V  
 Resolution: 0.2 V

**Remote OVP Adjustment:**

Range: 2.0 V to 64.5 V (the OVP trip point = 2 V + 1.04 X soft voltage limit)  
 Resolution: 0.25 V

Accuracy:  $\pm 0.7$  V. The OVP circuit will trip when the voltage between the + output and the outboard side of the current monitoring resistor equals the set voltage. This could be as much as 1.35 V above the voltage between the  $\pm$  S terminals.

Temperature Coefficient: 250 PPM/ $^{\circ}\text{C}$

**Amplified Current Monitor:** Scale Factor 0-5 V monitor output for 0-10 A output current.

Accuracy: 0.1% + 7 mV typical  
 Output Impedance: 10 k $\Omega$  nominal

**RFI Specifications:** Meets VDE 0871/6.78 Level A

# Section I

## GENERAL INFORMATION

### 1-1 INTRODUCTION

1-2 This Operating Manual contains a description of the Model 6034A System Power Supply, including specifications, and installation and operating instructions. The 6034A User's Guide, HP Part Number 06034-90003, contains basic operating instructions for the 6034A along with programming examples for specific Hewlett-Packard computers and desktop calculators.

### 1-3 SPECIFICATIONS

1-4 Instrument specifications are listed in Table 1-1. These specifications are the performance standards or limits against which the instrument is tested. Supplemental information is also listed in Table 1-1, including typical, but non-warranted, characteristics.

### 1-5 SAFETY CONSIDERATIONS

1-6 This product is a Safety Class 1 instrument (provided with a protective earth terminal). The instrument and this manual should be reviewed for safety markings and instructions before operation. Refer to the Safety Summary page at the beginning of this manual for a summary of general safety information. Safety information for specific procedures is located at appropriate places in this manual.

### 1-7 INSTRUMENT AND MANUAL IDENTIFICATION

1-8 Hewlett-Packard power supplies are identified by a two-part serial number. The first part is the serial number prefix, a number-letter combination that denotes the date of a significant design change and the country of manufacture. The first two digits indicate the year (21 = 1981, 22 = 1982, etc), the second two digits indicate the week, and "A" designates the U.S.A. The second part of the serial number is a different sequential number assigned to each power supply, starting with 00101.

1-9 If the serial number on your instrument does not agree with those on the title page of this manual, a yellow Manual Changes sheet supplied with the manual defines the difference between your instrument and the instrument described by this manual. The change sheet may also contain information for correcting errors in the manual.

### 1-10 DESCRIPTION

1-11 The Model 6034A System Power Supply is an HP-IB programmable unit that provides laboratory-grade performance with the high efficiency of switching regulation techniques. Autoranging allows the supply to provide at least 200

watts output power over a wide range of output voltage and current combinations without the user having to select the proper output range. Output voltage and current are continuously indicated on individual meters. LED indicators show the complete operating state of the unit. Front-panel controls allow the user to set output voltage, current, and overvoltage protection trip level. Overvoltage protection (OVP) protects the user's load by quickly and automatically interrupting energy transfer if a preset trip voltage is exceeded.

1-12 The 6034A can be both a listener and a talker on the HP-IB. Output voltage and current can be sent directly to the 6034A in volts and amps. Service can be requested asynchronously for each of six reasons, and the unit responds to a serial poll by identifying the nature of any faults. Upon command the 6034A will measure its output voltage or current and put the value on the HP-IB.

1-13 The following parameters and features can be controlled via the HP-IB:

- Output voltage
- Output current
- Output power circuits off and on (Device Clear also turns output circuits off)
- Soft voltage limit (includes OVP trip level)
- Soft current limit
- Limit mode - CV or CC
- Time delay after output trigger or reset before requesting service for limit mode or overrange
- Service request masks
- Trigger to implement latest mode, output voltage and current, and OVP trip level (Device Trigger also triggers unit)
- Trigger for output voltage or current measurement

1-14 Output connections are made to rear-panel screw-on terminals. Either the positive or negative output terminal may be grounded, or the output may be floated up to  $\pm 240$  Vdc (including output voltage) from chassis ground. Output voltage can be locally or remotely sensed, and the 6034A can be operated in multiple-supply combinations for increased output voltage or current capability.

1-15 The 6034A is considerably smaller, lighter, and more efficient than older-design supplies with similar output-power capability. The unit is fan cooled and is packaged in a Hewlett-Packard System II - compatible modular enclosure, which is sturdy, attractive, and provides easy access for servicing.

### 1-16 OPTIONS

1-17 Options are standard factory modifications or accessories that are delivered with the instrument. The following options are available with the 6034A. Note lower output power

and voltage specifications for Option 100. Option 100 is described in Appendix A.

<u>OPTION NO.</u>	<u>DESCRIPTION</u>
100	Input power: 87 to 106 Vac, 48-63 Hz, single phase. Output: 150 W, 50 V, 10 A.
220	Input power: 191 to 233 Vac, 48-63 Hz, single phase.
240	Input power: 208 to 250 Vac, 48-63 Hz, single phase.
907	Front handle kit.
908	Rack flange kit.
909	Options 907 and 908 combined.
910	One additional operating and service manual for each Option 910 ordered.

## 1-18 ACCESSORIES

1-19 The System II Cabinet accessories listed below may be ordered with the power supply or separately from your local Hewlett-Packard Sales and Service Office (see list of addresses at the rear of this manual).

<u>HP PART NO.</u>	<u>DESCRIPTION</u>
5061-0089	Front handle kit for 5-1/4 inch high cabinets (will be shipped with instrument if ordered as Option 907).
1460-1345	Tilt stand (1) snaps into standard foot supplied with instrument, must be used in pairs.
5061-0077	Rack flange kit for 5-1/4 inch high cabinets (will be shipped with instrument if ordered as Option 908).
5061-0083	Rack flange/front handle kit for 5-1/4 inch high cabinets (will be shipped with instrument if ordered as Option 909).
1494-0018	Slide kit for installing 17-inch deep cabinet in HP rack enclosure.
1424-0025	Tilt slide kit, same as 1494-0018 plus permits tilting instrument up or down 90°.
1494-0023	Slide adapter kit, permits use of 1494-0018 kit in non-HP rack enclosure of adequate depth.
5060-0138	HP-IB non-metric to metric connector conversion kit.

## 1-20 HP-IB INTERCONNECTION CABLES AND CONNECTORS

1-21 Cables for interconnecting HP-IB devices are available in four different lengths. The connector block at both ends of each HP-IB cable has a plug on one side and a matching receptacle on the other, so that several cables may be connected in parallel, thus simplifying system interconnection. Lock screws provide secure mounting of each connector block to an HP-IB instrument, or to another cable connector block. All connectors supplied since 1975 use metric hardware (colored black). Accessories table lists kit for converting one non-metric (colored silver) cable and one or two instruments to metric hardware. The 10631 series of cables are lighter and more flexible than the 10833 series. The 10833 series of cables feature improved shielding to help improve overall RFI levels in many systems. The 10631 and 10833 series cables are completely compatible with one another, but the 10631 series cables will interrupt the continuity of the 10833 series shielding.

1-22 The 10834A extender was designed to help in cases where rear panel space results in difficult cabling situations. The extender provides clearance by extending the first connector block 2.3 cm away from the rear panel of the instrument.

### MODEL

10631A HP-IB Cable, 1 m (3.3 ft)  
 10631B HP-IB Cable, 2 m (6.6 ft)  
 10631C HP-IB Cable, 4 m (13.2 ft)  
 10631D HP-IB Cable, 0.5 m (1.6 ft)  
 10833A HP-IB Cable, 1 m (3.3 ft)  
 10833B HP-IB Cable, 2 m (6.6 ft)  
 10833C HP-IB Cable, 4 m (13.2 ft)  
 10833D HP-IB Cable, 0.5 m (1.6 ft)  
 10834A HP-IB Connector Extender

## 1-23 ORDERING ADDITIONAL MANUALS

1-24 One manual is shipped with each power supply. Additional manuals may be purchased directly from your local Hewlett-Packard Sales office. Specify the model number, instrument serial number prefix, and the manual part number provided on the title page. (When ordered at the same time as the power supply, additional manuals may be purchased by adding Option 910 to the order and specifying the number of additional manuals desired.)

## 1-25 RELATED DOCUMENTS

1-26 The following documents may be useful for designing HP-IB systems. The HP documents can be ordered from your local HP Sales Office.

6034A User's Guide, HP Part Number 06034-90003.

Condensed Description of the Hewlett-Packard Interface Bus, HP Part Number 59401-90030, March, 1975, 18 pages.

Tutorial Description of the Hewlett-Packard Interface Bus, HP Part Number 59300-90007, November, 1980, 92 pages.

Table 1-1. Specifications and Supplemental Characteristics (cont.)

<p><b>DC Output Isolation:</b> Either output terminal may be floated up to <math>\pm 240</math> Vdc (including output voltage) from earth ground.</p> <p><b>Temperature Rating:</b> <b>Operating:</b> 0 to +55°C      <b>Storage:</b> -40 to +75°C Unit is fan cooled. A thermostat turns off output power if temperature rises above a critical level; resets automatically.</p> <p><b>Reverse Voltage Protection:</b> Maximum permissible reverse current caused by reverse voltage impressed across output terminals. 10 A continuous</p> <p><b>Remote Sensing:</b> Maintains nominal voltage at load by correcting for load-lead voltage drop of up to 0.5 V per lead.</p>	<p><b>AC Input:</b> Two internal switches and one internal jumper permit operation from 120, 220, or 240 Vac (-13%, +6%); 48-63 Hz. (Option 100 is factory set only.) 325 W @ 200 W output 600 VA @ 200 W output</p> <p><b>Peak Inrush Current: Typical Values</b> @25°C ambient: 25 A 30 seconds after turn-off: 30 A @55°C ambient: 50 A 30 seconds after turn-off: 60 A</p> <p><b>Dimensions:</b> See Figure 2-1.</p> <p><b>Weight:</b> Net: 9.9 kg (20 lb.)      Shipping: 10.4 kg (23 lb.)</p>
--	---

## Section II INSTALLATION

### 2-1 INTRODUCTION

2-2 This section contains instructions for checking and repacking the unit, bench or rack mounting, connecting the unit to ac input power, and converting the unit from one line voltage to another if required. Instructions for connecting load and HP-IB cables, and for setting the HP-IB address are given in Section III.

### 2-3 INITIAL INSPECTION

2-4 Before shipment, this instrument was inspected and found to be free of mechanical and electrical defects. As soon as the instrument is unpacked, inspect for any damage that may have occurred in transit. Save all packing materials until the inspection is completed. If damage is found, file claim with carrier immediately. The Hewlett-Packard Sales and Service office should be notified as soon as possible.

### 2-5 Mechanical Check

2-6 This check should confirm that there are no broken knobs or connectors, that the cabinet and panel surfaces are free of dents and scratches, and that the meter face and rear-panel terminal block cover are not scratched or cracked.

### 2-7 Electrical Check

2-8 Section V contains complete verification procedures for this instrument. Section III contains an abbreviated check which can be used quickly to place the unit into operation. Refer to the inside front cover of the manual for Certification and Warranty statements.

### 2-9 PREPARATION FOR USE

2-10 In order to be put into service, the 6034A must be

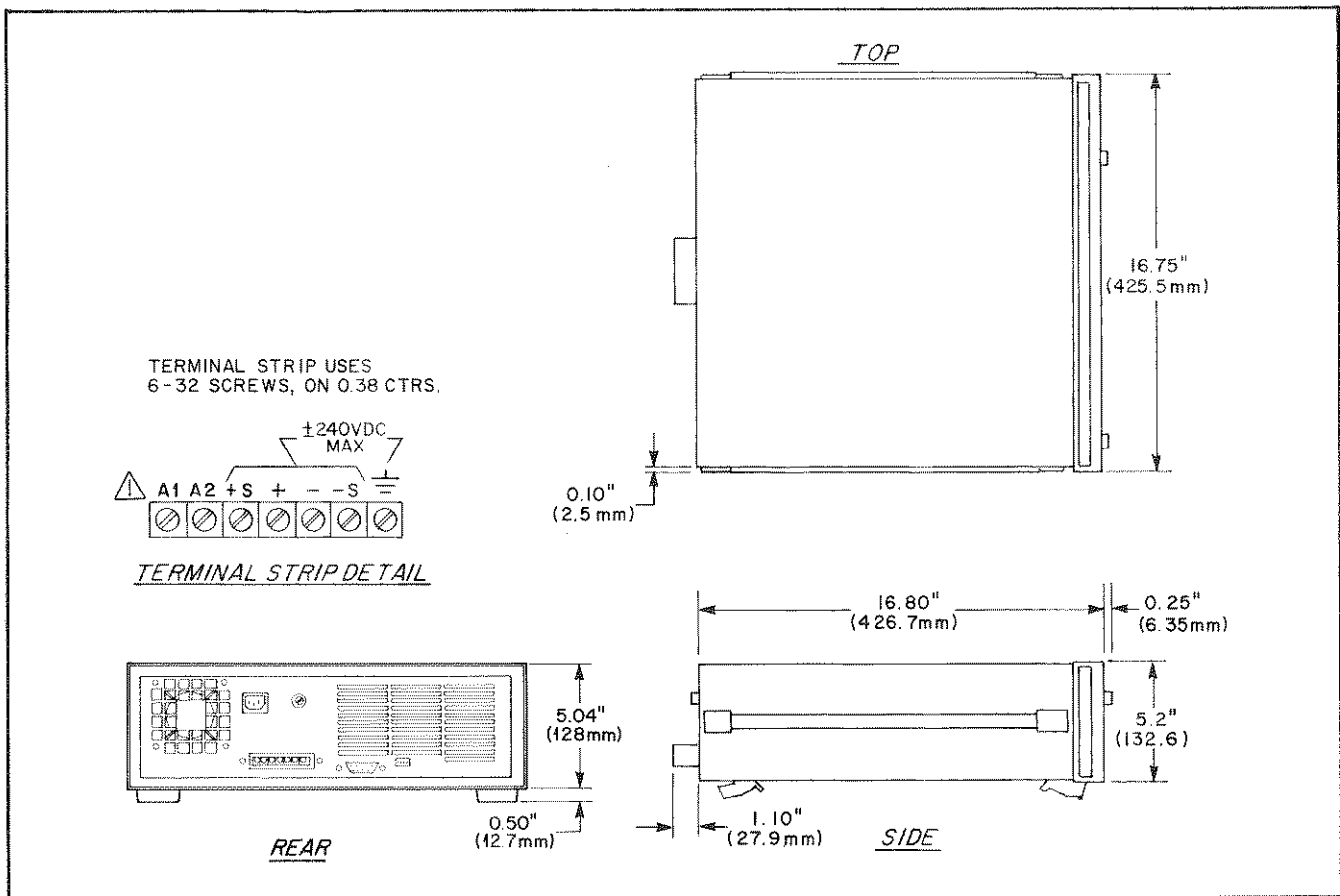

Figure 2-1. Outline Diagram.



connected to an appropriate ac input power source. Also, the line voltage for which the unit is set and the rear-panel fuse must be checked. Additional steps may include line voltage conversion and rack mounting. Do not apply power to the instrument before reading paragraph 2-19.

## 2-11 Location and Cooling

2-12 The instrument is fan cooled and must be installed with sufficient space behind the instrument for air flow. It should be used in an area where the ambient temperature does not exceed +55°C.

## 2-13 Outline Diagram

2-14 Figure 2-1 illustrates the outline shape and dimensions of the cabinet.

## 2-15 Bench Operation

2-16 The instrument cabinet has plastic feet, which are shaped to ensure self aligning when stacked with other Hewlett-Packard System II cabinets.

## 2-17 Rack Mounting

2-18 The unit can be mounted in a standard 19-inch rack panel or enclosure. Rack mounting accessories for this unit are listed in the ACCESSORIES paragraph in Section I. Complete installation instructions are included with each rack mounting kit.

## 2-19 Input Power Requirements

2-20 This supply may be operated from a nominal 100V, 120V, 220V or 240V single-phase ac power source (48-63Hz). The input voltage range and input current required for each of the nominal inputs are listed below. The maximum input power (at high line, full load) required for any input is 325 watts. A label on the rear panel indicates the nominal line voltage for which the instrument was set at the factory. If necessary, the user can convert the instrument from one line voltage option to another by following the instructions in paragraph 2-25.

Nominal Voltage	Line Voltage Range	Maximum Input Current
100V	87-106	5.6 A rms
120V	104-127	5.6 A rms
220V	191-233	3.0 A rms
240V	208-250	2.8 A rms

## 2-21 Power Cable

2-22 Model 6034A is shipped from the factory with a power-cord plug appropriate for the user's location. Figure 2-2 illustrates the standard configuration of power-cord plugs used by Hewlett-Packard. Below each drawing is the HP Part Number for a replacement power cord equipped with a plug of

that configuration. If a different power cord is required, contact the nearest Hewlett-Packard Sales and Service office.

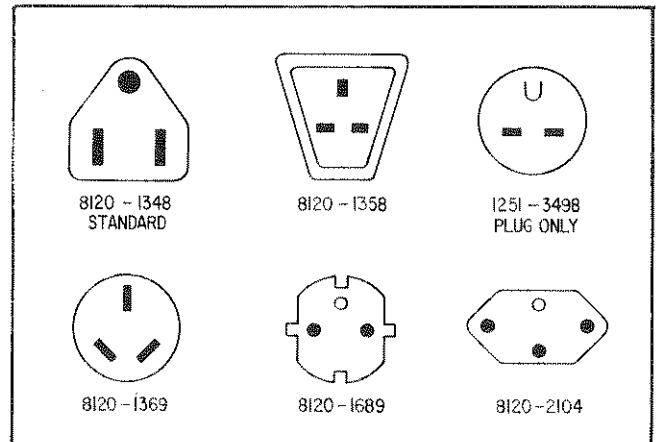

Figure 2-2. Power-Cord Plug Configurations

2-23 To protect operating personnel, the National Electrical Manufacturers Association (NEMA) recommends that the instrument panel and cabinet be grounded. This instrument is equipped with a three-conductor power cable; the third conductor is the ground conductor. When the cable is plugged into an appropriate receptacle the instrument is grounded. In no event shall this instrument be operated without an adequate cabinet ground connection.

2-24 The offset pin on the standard power cable three-prong connector is the ground connection. If a two-contact receptacle is encountered, it must be replaced with a properly grounded three-contact receptacle in accordance with the National Electrical Code, local codes and ordinances. The work should be done by a qualified electrician.

### NOTE

*Generally, it is good practice to keep the ac input lines separated from signal lines.*

## 2-25 LINE VOLTAGE OPTION CONVERSION

### CAUTION

*Conversion to or from 100V operation requires replacement of jumpers and components in addition to the line voltage components, and is to be done only at the factory. Failure to place these jumpers properly will result in an output that does not correspond to programmed values.*

2-26 Line voltage conversion is accomplished by adjusting three components; the two-section line select switch S2, line-voltage jumper W1, and rear-panel line fuse F1. To convert the

supply from one line voltage option to another, proceed as follows:

**WARNING**

*Some components and circuits are at ac line voltage even with the line switch off. To avoid electric shock hazard, disconnect line cord and load before removing cover.*

a. Remove top and bottom covers from instrument by removing three screws (one on each side and one in center) that secure each cover to rear panel; slide cover to rear and lift off.

b. The line voltage select switch is located just to the right of center of the instrument (as viewed from front), about five inches behind front panel (see Figure 2-3). Use a small-blade screwdriver to set the two switch sections to match the pattern silkscreened on p.c. main board as shown in Figure 2-3. For example, to set switches for 120V operation (as

illustrated), move forward switch section so that its white slot is toward front of instrument and move rearward switch section so its white slot is toward rear of instrument.

c. The line voltage jumper W1 is located about 2-1/2 inches in front of rear-panel terminal block (see Figure 2-3). (A dashed line is silkscreened on A3 board from vicinity of S2 to W1). Jumper must be soldered in place for 120V operation, and must be removed for 220V or 240V operation.

d. Check rating of fuse F1 installed in rear-panel fuseholder and replace with correct value if necessary. Do not use slow-blow fuses. For 120V operation, use 6A fuse, HP Part Number 2110-0056. For 220V or 240V operation, use 4A fuse, HP Part Number 2110-0055. Fuse A1F2 (near S2) should be 1.25 A, HP Part Number 2110-0094, for all input voltages. Fuse A4F1 (near rear left corner of instrument) should be 750 mA, HP Part Number 2100-0063 for all input voltages.

e. Replace covers and mark the supply clearly with a tag or label indicating correct line voltage and fuse to be used.

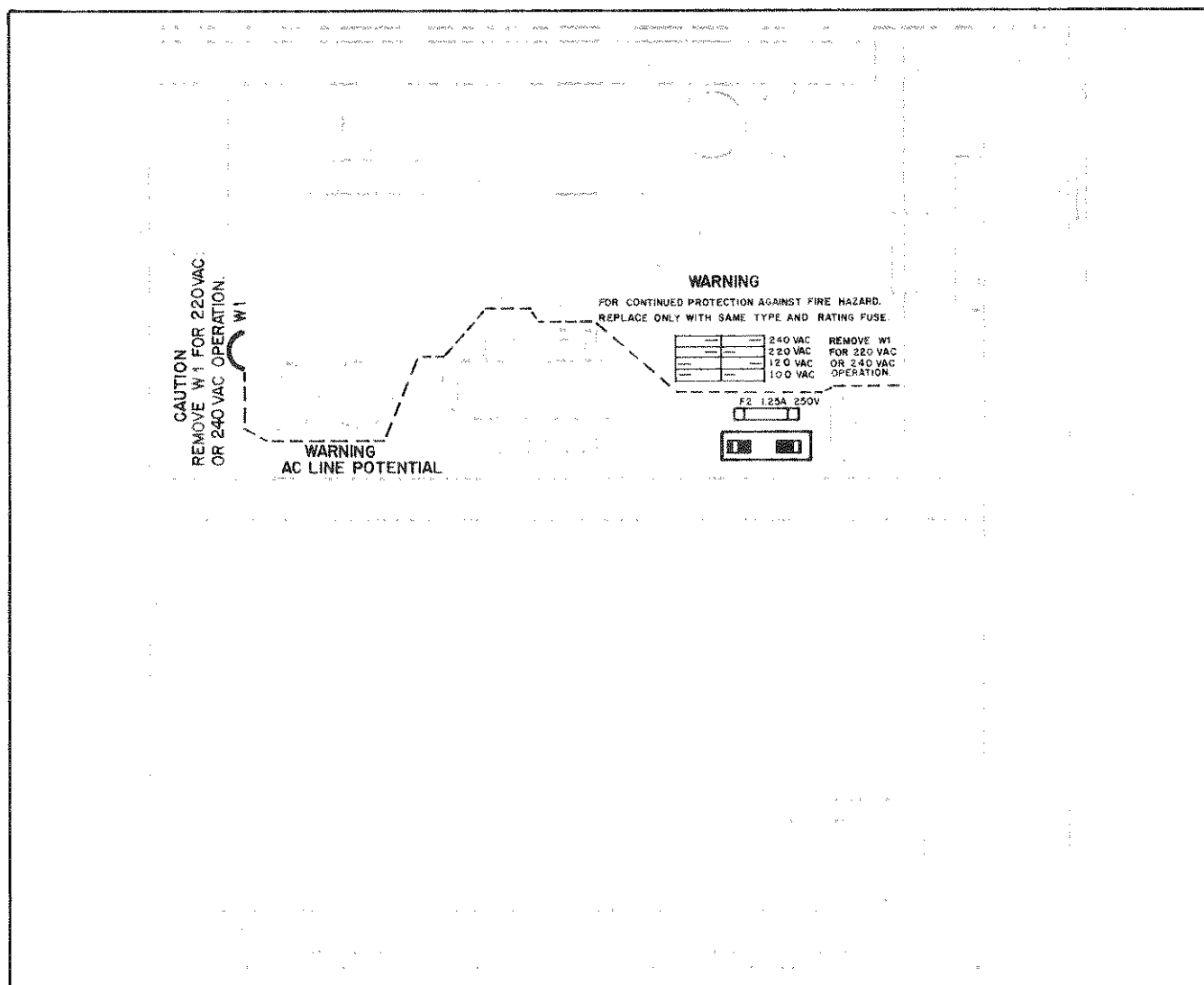

Figure 2-3. Line Voltage Selection Components

**2-27    REPACKAGING FOR  
         SHIPMENT**

2-28    To insure safe shipment of the instrument, it is recommended that the package designed for the instrument be used. The original packaging material is reusable. If it is not

available, contact your local Hewlett-Packard Sales and Service office to obtain the materials. This office will also furnish the address of the nearest service office to which the instrument can be shipped. Be sure to attach a tag to the instrument specifying the owner, model number, full serial number, and service required, or a brief description of the trouble.

## Section III OPERATING INSTRUCTIONS

### 3-1 INTRODUCTION

3-2 This section describes the operating controls and indicators, turn-on checkout procedures, and operating procedures and considerations for the Model 6034A. Local (front-panel) and remote (via HP-IB) operation are described separately, but the user should become familiar with both methods of operation. Information in this section through paragraph 3-64 and in paragraphs 3-70 through 3-73 applies to both local and remote operation. Programming examples for specific Hewlett-Packard computers and desktop calculators are given in 6034A Power Supply User's Guide, HP Part Number 06034-90003. More theoretical descriptions regarding the operational features of power supplies in general are given in the DC Power Supply Handbook, Application Note 90B (available at no charge from your local Hewlett-Packard Sales Office).

#### WARNING

*Before the instrument is turned on, all protective earth terminals, extension cords, and devices connected to the power supply should be connected to a protective earth ground. Any interruption of the protective earth grounding will cause a potential shock hazard that could result in personal injury. Only fuses of the specified type with the required current rating should be used. Do not use short circuited fuseholders. To do so could cause a shock hazard.*

### 3-3 CONTROLS AND INDICATORS

3-4 The front-panel controls and indicators are shown in Figure 3-1 and described in Table 3-1. Table 3-1 also lists the paragraphs in which use of the controls and indicators is described.

### 3-5 OUTPUT RANGE FOR AN AUTORANGING POWER SUPPLY

3-6 The Model 6034A can operate as a constant voltage (CV) or constant current (CC) source over a wide range of output voltage and current combinations. Whether the 6034A operates as a CV or a CC source depends on the output voltage and current settings and the value of load resistance.

3-7 Figure 3-2 shows the overall output range of the supply, with three sample operating loci. Locus 1 is established with a voltage setting of 20 V and a current setting of 3 A. For any values of load resistance greater than the crossover value of 6.7 ohms, the supply operates in constant voltage mode. For values of load resistance less than the crossover value, the supply operates in constant current mode. The transition occurs automatically; no switches need be operated or connections changed. The front-panel MODE indicators show which mode is active. In local control, the 6034A powers on as a voltage source, and either the CV (NORMAL) or CC (LIMIT) indicator will be on. (The 6034A can be remotely programmed to operate as a current source and then returned to local control. As a current source, either the CC (NORMAL) or CV (LIMIT) indicator will be on.) In remote control, the 6034A can

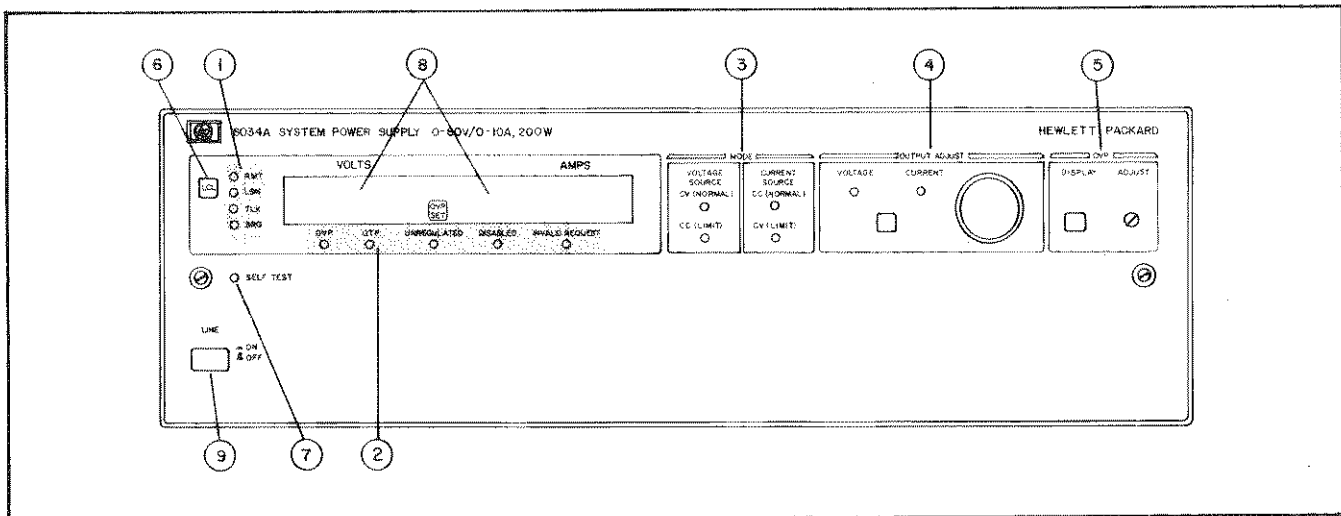

Figure 3-1. Front-Panel Controls and Indicators

Table 3-1. Controls and Indicators

Number	Controls/Indicators	Description	Paragraph #
1	<p><b>HP-IB Status Indicators</b></p> <p>In test mode, HP-IB status indicators flash on and off to indicate which test, if any, the unit has failed (see Paragraph 3-14).</p>	<p>RMT indicates that power supply is under remote control.</p> <p>LSN indicates that power supply is addressed to listen.</p> <p>TLK indicates that power supply is addressed to talk.</p> <p>SRQ indicates that power supply is requesting service from controller.</p>	<p>3-73, 3-79</p> <p>3-85</p> <p>3-85</p> <p>3-87, 3-90</p>
2	<p><b>Power Supply Status Indicators</b></p> <p>In test mode, power supply status indicators flash on and off to indicate the particular fault within a failed test (see Paragraph 3-14).</p>	<p>OVP indicates that overvoltage protection circuit has tripped and is latched.</p> <p>OTP indicates that overtemperature protection circuit has been activated.</p> <p>UNREGULATED indicates that neither the CV or CC loops are regulating the power supply output (either from an overrange condition or low ac input voltage).</p> <p>DISABLED indicates that output power circuits have been turned off via HP-IB.</p> <p>INVALID REQUEST indicates either a syntax error or a soft limit error in an instruction was received via HP-IB.</p>	<p>3-25, 3-81</p> <p>3-81</p> <p>3-11, 3-81</p> <p>3-124</p> <p>3-81</p>
3	<p><b>MODE Indicators</b></p> <p>Unit initializes as a voltage source, mode (CV or CC) depends on voltage and current settings and load resistance.</p>	<p>CV (NORMAL) indicates that power supply has been programmed as a voltage source and is regulating its output at a constant voltage.</p> <p>CC (LIMIT) indicates that power supply has been programmed as a voltage source but is regulating its output at a constant current.</p> <p>CC (NORMAL) indicates that power supply has been programmed as a current source and is regulating its output at a constant current.</p> <p>CV (LIMIT) indicates that power supply has been programmed as a current source but is regulating its output at a constant voltage.</p>	<p>3-7, 3-15</p> <p>3-7, 3-15</p> <p>3-7</p> <p>3-7</p>

Table 3-1. Controls and Indicators (cont.)

Number	Controls/Indicators	Description	Paragraph #
4	<p><b>OUTPUT ADJUST Controls</b></p> <p>OUTPUT ADJUST knob is a two-speed rotary pulse generator (RPG); faster rotation causes greater rate of change per rotation.</p>	<p>OUTPUT ADJUST knob functions as either a voltage control or a current control, as determined by the pushbutton switch and indicated by whichever indicator, VOLTAGE or CURRENT, is on. OUTPUT ADJUST controls function only when the power supply is under local control. Pushbutton switch is also used to enter and exit test mode; see Section V.</p>	3-15, 3-73 through 3-77
	<p><b>OVP Controls</b></p>	<p>The recessed ADJUST control sets overvoltage protection trip voltage. DISPLAY pushbutton switch causes voltmeter to display the operating OVP trip voltage (lower of OVP trip voltage set locally by ADJUST or OVP trip voltage determined by remotely sent soft voltage limit). When DISPLAY is pushed in, OVP SET light to the right of voltmeter indicates that voltmeter is displaying OVP trip voltage.</p>	3-15, 3-26
6	<p><b>LCL Pushbutton Switch</b></p>	<p>LCL returns power supply to local control (unless local lockout command has been received via HP-IB).</p>	3-78, 3-97
7	<p><b>SELF TEST Indicator</b></p>	<p>Indicates that unit is in self test (always performed at turn-on) or in user-selected test mode.</p>	3-14
8	<p><b>Meters</b></p>	<p>Indicate output VOLTS and AMPS. 3 1/2 digit voltmeter has two ranges, 20.00 V and 200.0 V, with automatically positioned decimal point. OVP SET light to right of voltmeter indicates that voltmeter is displaying OVP trip voltage (200.0 V range). 3 1/2 digit ammeter has one range, 20.00 A.</p>	3-11, 3-15
9	<p><b>LINE Switch</b></p>	<p>Turns ac input power on and off.</p>	3-15

be programmed to operate either as a voltage source (either the CV (NORMAL) or CC (LIMIT) indicator will be on), or as a current source (either the CC (NORMAL) or CV (LIMIT) indicator will be on). Note that the 6034A switches between CV and CC mode in the same way regardless of whether the unit is programmed to operate as a voltage source or as a current source. The only difference is whether the 6034A requests service when the unit switches to CC or when it switches to CV.

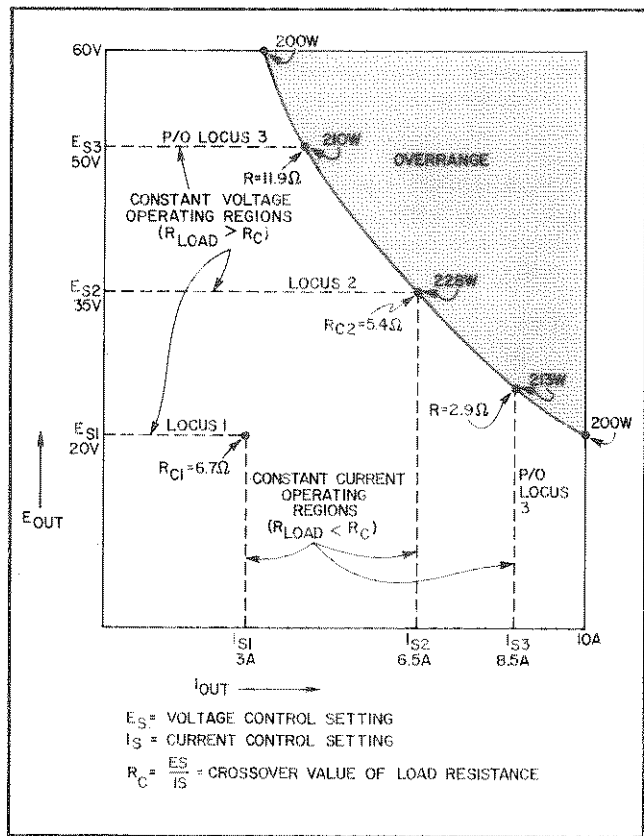

Figure 3-2. Overall Output Range with Three Sample Operating Loci

3-8 Locus 2 is established with a voltage setting of 35 V and a current setting of 6.5 A. Its crossover load resistance is 5.4 ohms, and lies on the rated-output-power boundary.

3-9 A rectangular operating locus will be established for all voltage and current settings within the rated-output-power boundary. The power supply operates at one point on that locus, depending on the load resistance. However, if the voltage and current settings are such that the boundary can be exceeded, as in locus 3, the supply will go into overrange if the load resistance falls within a critical band (refer to next paragraph).

3-10 **Overrange.** The supply will be driven into overrange (shaded area of Figure 3-2) if the voltage and current settings are set above the output power rating and the load resistance falls within a critical band. For example, assume a voltage setting of 50 V and a current setting of 8.5 A, as in locus 3 on

Figure 3-2. For all load resistances above 11.9 ohms (which is the critical value) the supply would operate normally in constant voltage mode. If the load resistance were to fall much below 11.9 ohms, however, the supply would be forced into overrange. If the load resistance continued to decrease to 2.9 ohms, the supply would automatically come out of overrange and into constant current mode at the 8.5 A, 25 V point. (The supply will probably go out of regulation while operating in the overrange region, refer to Paragraph 3-12).

3-11 Anytime the supply operates in overrange, the MODE indicators turn off and the UNREGULATED indicator lights. The VOLTS and AMPS meters indicate the voltage and current being supplied to the output. (The product of the two readings will exceed 200 watts.)

3-12 The supply can operate in the overrange region (beyond the rated-output-power boundary) for sustained periods without being damaged. However, the supply is not guaranteed to meet specifications in overrange. Output ripple increases substantially and regulation is seriously degraded.

#### NOTE

*Under certain conditions of line and load, it is possible for the supply to provide more than rated output power and still maintain regulation. If this occurs, the unit will operate normally and the UNREGULATED indicator will be off. However, the slightest change in either line or load may cause the unit to go out of regulation. Operation of the unit beyond the rated-output-power boundary is not recommended under any circumstances.*

#### 3-13 TURN-ON CHECKOUT PROCEDURE

3-14 The 6034A performs a self test of its RAM, real-time clock, and ROM circuits each time power is turned on. The tests take less than one second to complete, and all indicators are on while the tests are in progress. If the unit fails self test the SELF TEST indicator will remain on and some or all of the other indicators will remain on. Depending on the location of the failure, the indicators may flash on and off. Flashing indicators always indicate a failure, but, because flashing is controlled by the microprocessor, a failure may cause the indicators to remain on without flashing. More extensive internal tests can be accessed in test mode if the unit fails self test or if there are other indications that the unit may not be operating properly; refer to Section V.

#### CAUTION

*Do not enter test mode with load connected. 6034A will indicate test failure and load may be damaged by 60-volt 1-ampere output. Refer to Section V for use of test mode.*

## NOTE

Because the unit is testing itself, it is not possible to guarantee that the unit will provide an unambiguous indication of all possible failures. For example, a failure in the hardware used for self test or in the core of the microprocessor may prevent the unit from indicating that it has not passed self test. Refer to the troubleshooting procedures in Section V if there is any reason to suspect that the unit may be malfunctioning.

3-15 The following procedure ensures that the unit is operational, and may be used as an incoming inspection check. Ensure that the rear-panel terminal block is strapped as shown in Figure 3-3 and that the screws are tightened securely. Check that the rear-panel label indicates unit is set for line voltage to be used. There should be no cables connected to the rear-panel HP-IB connector. Check that recessed OVP ADJUST control is fully clockwise.

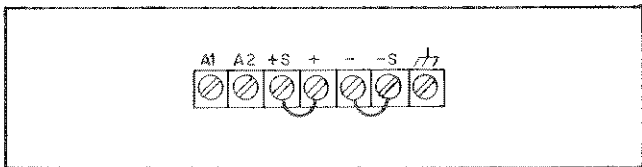

Figure 3-3. Factory-Set Terminal Block Strapping

- Press pushbutton LINE switch on (pushbutton in). Fan should operate, and after initial blinking of all indicators during self test, SRQ, CV (NORMAL), and VOLTAGE indicators should remain on.
- Press momentary-contact OVP DISPLAY pushbutton switch and observe that OVP SET indicator lights next to voltmeter and that voltmeter indicates  $64.5 \pm 0.1$  V (at room temperature).
- Turn OUTPUT ADJUST knob clockwise and ensure that output voltage increases from zero to full output voltage as indicated on voltmeter. CV (NORMAL) indicator should be on across entire range, indicating that unit is in constant voltage mode.
- Check overvoltage circuit by turning OVP ADJUST control counterclockwise until OVP circuit trips. Output voltage should drop to 0 to  $-0.5$  V, CV (NORMAL) indicator should turn off, and OVP indicator should turn on (SRQ and VOLTAGE indicators remain on).
- Reset OVP circuit by turning OVP ADJUST control fully clockwise and turning unit off for at least two seconds and then back on. Output voltage should come on at zero volts.
- To check constant current circuit, turn unit off and connect a short (AWG #18 or larger) across + and - terminals on rear panel.
- Turn unit on and turn OUTPUT ADJUST knob clockwise until CV (NORMAL) indicator turns off and CC (LIMIT) indicator turns on.

- Press momentary-contact OUTPUT ADJUST pushbutton switch once. VOLTAGE indicator should turn off and CURRENT indicator should turn on.
- Turn OUTPUT ADJUST knob clockwise and ensure that output current increases from 1A to full output current as indicated on ammeter. CC (LIMIT) indicator should be on across entire range, indicating that unit is in constant current mode. (In local control, unit powers on as a voltage source and the CV circuit normally regulates the output. Therefore, when unit switches to constant current mode, the CC circuit is said to be limiting the output. The 6034A can be programmed to be a current source only by remote control; it can then be returned to local control. Note that the operation of the unit is the same in either case; the only thing that changes is which mode is defined as normal and which is defined as limiting.)
- Turn off supply, remove short from output, and read following instructions before connecting load to supply.

## 3-16 INITIAL SETUP AND INTERCONNECTIONS

### WARNING

Disconnect input ac power before changing any rear-panel connections and make certain all wires and straps are properly connected and terminal block screws are securely tightened before reapplying power. Be certain to replace terminal block cover before reapplying power.

## 3-17 Connecting the Load

3-18 Load connections to the power supply are made at the + and - terminals on the rear-panel terminal block. To satisfy safety requirements, the wires to the load should be at least heavy enough not to overheat while carrying the power supply output current that would flow if the load were shorted. Stranded AWG #16 wire is rated for 12.7 A at 105°C conductor temperature. Stranded AWG #14 wire is rated for 14.8 A at 80°C. (The maximum allowable conductor temperature is based on 60°C ambient temperature plus 20°C or 45°C temperature rise due to continuous dc current.) These ratings are based on use of a twisted pair to connect the load to the supply. **Generally, heavier wire is required to obtain good regulation at the load.** If load regulation is critical, use remote voltage sensing (Paragraph 3-30).

3-19 The terminal block is protected by an impact resistant plastic cover, which is secured to the unit with two #6-32 screws. Be certain to replace the cover after making connections.

3-20 If multiple loads are connected to one supply, each load should be connected to the supply's output terminals using separate pairs of connecting wires. This minimizes mutual coupling effects and takes full advantage of the supply's low output impedance. Each pair of connecting wires should be as short as possible and twisted or shielded to reduce noise pickup.



3-21 If load considerations require the use of output distribution terminals that are located remotely from the supply, then the power supply output terminals should be connected to the remote distribution terminals by a pair of twisted or shielded wires and each load should be separately connected to the remote distribution terminals. Remote voltage sensing is required under these circumstances (Paragraph 3-30). Sense either at the remote distribution terminals, or (if one load is more sensitive than the others) directly at the most critical load.

3-22 Either positive or negative voltages can be obtained from the supply by grounding one of the output terminals. It is best to avoid grounding the output at any point other than the power supply output terminals to avoid regulation problems caused by common-mode current flowing through the load leads to ground. Always use two wires to connect the load to the supply regardless of where or how the system is grounded. Never ground the system at more than one point. This supply can be operated with either output terminal up to  $\pm 240$  volts dc (including output voltage) from ground.

3-23 The PARD specifications in Table 1-1 apply at the power supply output terminals. However, noise spikes induced in the load leads at or near the load may affect the load although the spikes are inductively isolated from the power supply. To minimize voltage spikes at the load, connect a bypass capacitor as shown in Figure 3-4. With this setup, peak-to-peak noise at the load can actually be reduced to a level well below the value specified at the 6034A output terminals.

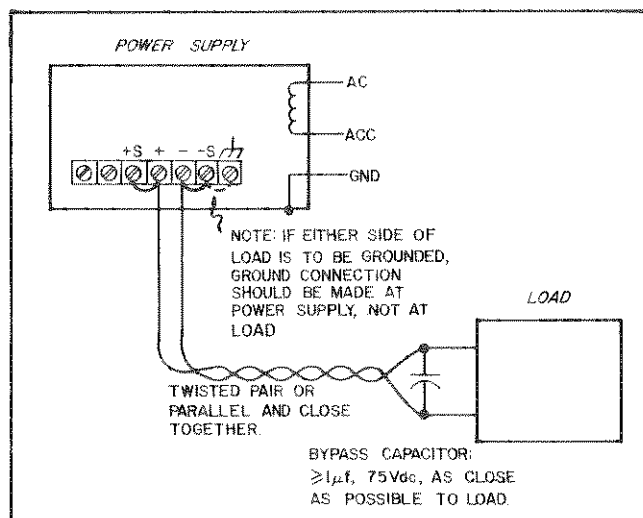

Figure 3-4. Connecting a Bypass Capacitor

### 3-24 Overvoltage Protection (OVP)

3-25 The overvoltage trip point can be adjusted at the front panel or remotely via HP-IB. OVP will trip at the lower of the two values, regardless of whether the 6034A is in local or remote control. The approximate trip voltage range is from two volts to 64.5 volts. When the OVP circuit trips, the supply is inhibited and delivers no output power, and the OVP indicator turns on. See note following Paragraph 3-32 for OVP adjustment with remote sensing.

3-26 **Local Adjustment.** OVP is set locally by the recessed single-turn OVP ADJUST potentiometer on the front panel. Rotating the control clockwise sets the trip voltage higher. (It is set to maximum at the factory.) When adjusting the OVP trip point, the possibility of false tripping must be considered. If the trip voltage is set too close to the supply's operating voltage, a transient in the output would falsely trip the OVP. For this reason it is recommended that the OVP trip voltage be set higher than the output voltage by at least 1.5 volts +1% of the output voltage. To adjust the OVP trip voltage at the front panel, proceed as follows:

- Turn on supply and hold OVP DISPLAY pushbutton in. OVP SET indicator to right of voltmeter turns on to indicate that voltmeter is displaying the OVP trip voltage.
- Insert a small-blade screwdriver through hole in front panel and adjust OVP trip voltage to desired level.

3-27 **Local OVP Reset.** To reset the OVP locally, the ac LINE switch must be turned off for a least one second and then back on. The cause of the overvoltage must be removed before the OVP circuit is reset, or the circuit will trip again immediately. Turning ac power off and back on will reset OVP regardless of whether the trip voltage was set locally or remotely. If the OVP circuit trips continuously check the load and/or the trip voltage.

3-28 **Remote Adjustment.** OVP is set remotely as a function of the soft voltage limit sent to the 6034A (see Paragraph 3-117). The OVP trip voltage is two volts plus 1.04 times the soft voltage limit. For example, if a soft voltage limit of 30 V is set, the OVP trip voltage will be 33.2 V  $([1.04 \times 30] + 2)$ . Because the 6034A initializes at power on with a soft voltage limit of 60 V, the remote OVP initializes at 64.5 V. Remember that the lower OVP trip voltage, either locally or remotely set, is the level displayed by OVP DISPLAY and the level at which the unit trips, regardless of whether the unit is in local or remote control.

3-29 **Remote OVP Reset.** OVP is reset remotely by sending "R" (Reset) to the 6034A (see Paragraph 3-124). The cause of the overvoltage must be removed before the OVP circuit is reset, or the circuit will trip again immediately. Sending "R" to the 6034A will reset OVP regardless of whether the trip voltage was set locally or remotely. If the OVP circuit trips continuously check the load and or the trip voltage.

### 3-30 Remote Voltage Sensing

3-31 Because of the unavoidable voltage drop developed in the load leads, the strapping pattern shown in Figure 3-3 will not provide the best possible voltage regulation at the load. The remote sensing connections shown in Figure 3-5 improve the voltage regulation at the load by monitoring the voltage there instead of at the supply's output terminals. (The advantages of remote sensing apply only during constant voltage operation.) When using remote sensing, turn off the power supply before changing the rear-panel strips, sense leads, or load leads. The following paragraphs discuss some precautions that should be observed when making a remote sensing installation.

3-32 The load leads should be of the heaviest practicable wire gauge, at least heavy enough to limit the voltage drop in

each lead to 0.5 volts. The power supply has been designed to minimize the effects of long load lead inductance, but best results will be obtained by using the shortest load leads practical.

### NOTE

*Remote voltage sensing compensates for a voltage drop of up to 0.5 V in each lead, and there may be up to a 0.35 V drop between the - output terminal and the internal sensing resistor, at which point the OVP circuit is connected. Therefore, the voltage sensed by the OVP circuit could be as much as 1.35 V more than the voltage being regulated at the load. It may be necessary to readjust the OVP trip voltage when using remote sensing.*

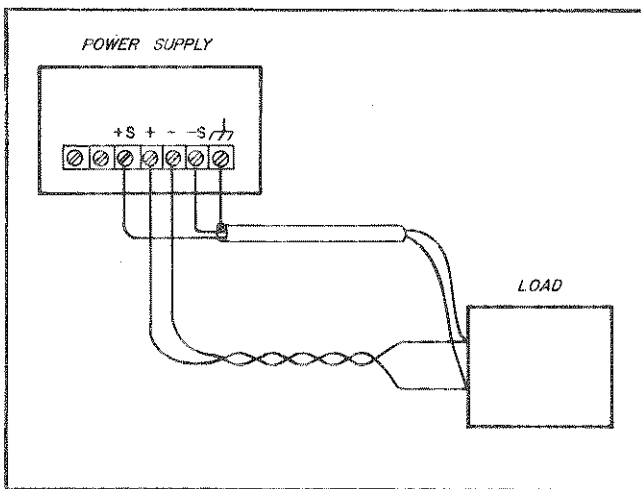

Figure 3-5. Remote Voltage Sensing

3-33 Since the sensing leads carry only a few milliamperes, the wires used for sensing can be much lighter than the load leads (AWG #22 is generally adequate), but they should be a shielded, twisted pair to minimize the pickup of external noise. Any noise picked up on the sensing leads will appear the the supply's output, and CV load regulation may be adversely affected. The shield should be grounded at one end only and should not be used as one of the sensing conductors. The sensing leads should be connected as close to the load as possible.

3-34 The sensing leads are part of the supply's programming circuits, so they should be connected in such a way as to make it unlikely that they might inadvertently become open circuited. If the sense leads open during operation, it is possible that the load voltage will rise above its programmed value. Therefore, it is recommended that no switch, relay or connector contacts be included in the remote sensing path.

### 3-35 Auto-Parallel Operation

3-36 Figure 3-6 shows the interconnections required to auto-parallel other autoranging power supplies with a 6034A as the master supply. An auto-parallel combination provides a greater current capability than can be obtained from a single supply, while ensuring that each supply will share the load proportionally to its own total power capability under all load conditions. For example, if a 200 W supply and a 1000 W supply were auto-paralleled, the 200 W supply would provide 1/6 the total current and the 1000 W supply would provide 5/6 the total current. The 6034A can be auto-paralleled only with other autoranging units, or with units that have current-monitoring output signals that are referenced to the - output and equal to 5 V at maximum rated current output. Up to eight supplies may be connected in auto-parallel, but the 6034A must be the master unit.

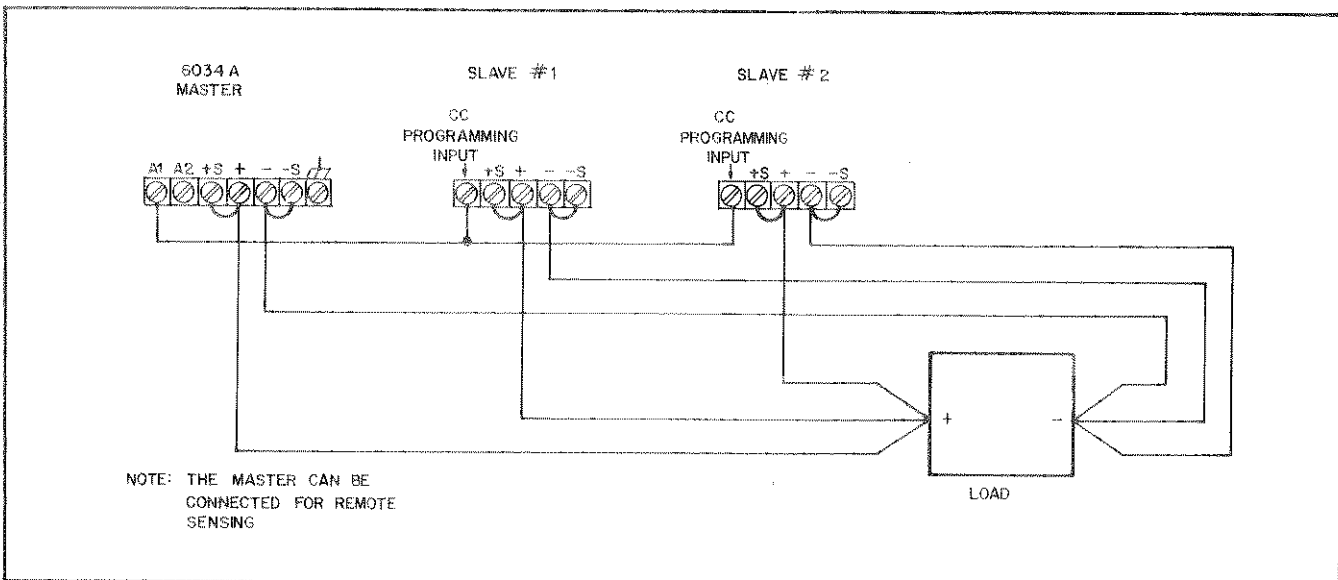

Figure 3-6. Auto-Parallel Operation

## NOTES

Load sharing will not be equal unless the voltage drops per lead are equal for all supplies. With supplies of equal capacity, use wires of equal length and gauge to connect each auto-paralleled supply to the load. If it is impractical to run leads from each supply to the load because of distance, leads of equal length should be run from each supply to common distribution terminals, with a single pair of leads run from the distribution terminals to the load. If one supply is providing more current than another, its load-lead resistance should be proportionately lower.

Because only the master can down-program the output of an auto-parallel combination, down-programming speed will be reduced under no-load conditions.

**3-37 Setting Output Voltage and Current.** The auto-parallel combination of supplies behaves as if it were a single constant voltage/constant current supply controlled by the voltage and current settings of the master supply. The current controls of the slave supplies must be disabled. On Hewlett-Packard autoranging supplies this is accomplished by removing the straps that connect the CC Current Source Output and CURRENT potentiometer terminals to the CC Programming Voltage Input terminal. The voltage controls of the slave supplies should be set above the desired output voltage to avoid interference with the master supply.

## NOTE

The voltage controls of Hewlett-Packard autoranging supplies can be disabled by replacing the strap connected between the CV Programming Voltage Input terminals and  $-S$  terminal with a resistor on each slave supply. The resistor value should be chosen to program a voltage higher than the desired output voltage. The Operating and Service Manuals for Hewlett-Packard autoranging supplies provide instructions for selecting the resistor value.

**3-38 Overvoltage Protection in Auto-Parallel.** Adjust the OVP trip point at the master supply. The slave supply OVP trip control(s) may be set to the same level or to maximum to disable them. If the master supply OVP trips, the master supply will program the slave supplies to zero output. If a slave OVP trips, it shuts down only that slave; the other units then supply more current until the master supply switches to CC mode.

**3-39 Auto-Parallel with Remote Voltage Sensing.** To combine auto-parallel operation with remote voltage sensing, connect the supplies as described above but remove the  $+S$  and  $-S$  jumpers from the master supply and connect the  $+S$  and  $-S$  terminals directly to the  $+$  and  $-$  ends of the load. Observe the precautions outlined under Paragraph 3-30.

## 3-40 Auto-Series Operation

3-41 Figures 3-7 and 3-8 show the interconnections required to operate two or more supplies in auto-series mode with a 6034A as the master supply. This mode of operation provides a greater voltage capability than can be obtained from a single supply. As many as four supplies can be connected in auto-series in the configuration shown in Figure 3-7, and as many as eight supplies can be connected if the power supply combination and load are center-tapped as in Figure 3-8 (with no more than four supplies on each side of the center tap). Either configuration allows all the supplies to be programmed simultaneously by the voltage and current settings of the master supply. Any power supply capable of auto-series operation can be used in the auto-series combination. The supply with the lowest current rating limits the maximum output current of the combination. **The 6034A must be the master supply**, and the master supply must be the one at the positive end of the series combination. Any point of the output can be grounded if desired, as long as no other point in the output is more than 240 volts (including output voltage) from ground.

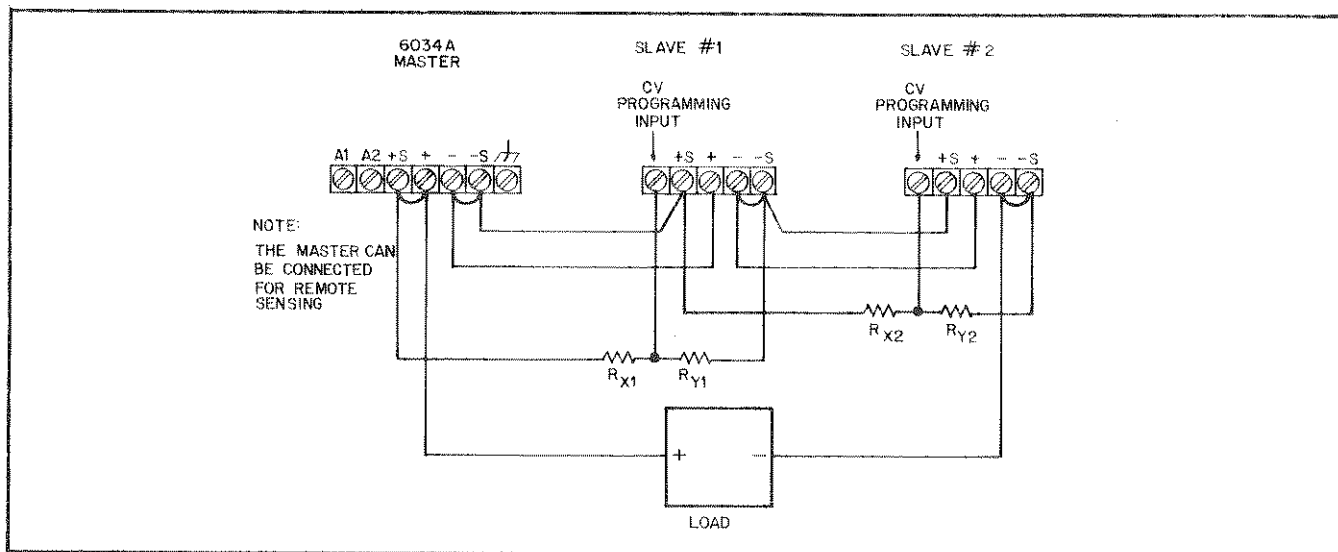

Figure 3-7. Auto-Series Operation

3-42 The output voltage of each slave supply varies in direct proportion to that of the master supply. The ratio of each slave supply's output voltage to the master supply's output voltage is established by the ratio of the resistors in the voltage divider connected between + Sense of the master supply and - Sense of the slave supply.

3-43 In applications in which coordinated positive and negative voltages are required, center tapping the supply combination and load as shown in Figure 3-8 allows simultaneous proportional control of both supply voltages.

**CAUTION**

*If more than four supplies are connected together in an auto-series combination, be certain that neither the more positive end nor the more negative end of the auto-series combination is more than 240 volts from ground.*

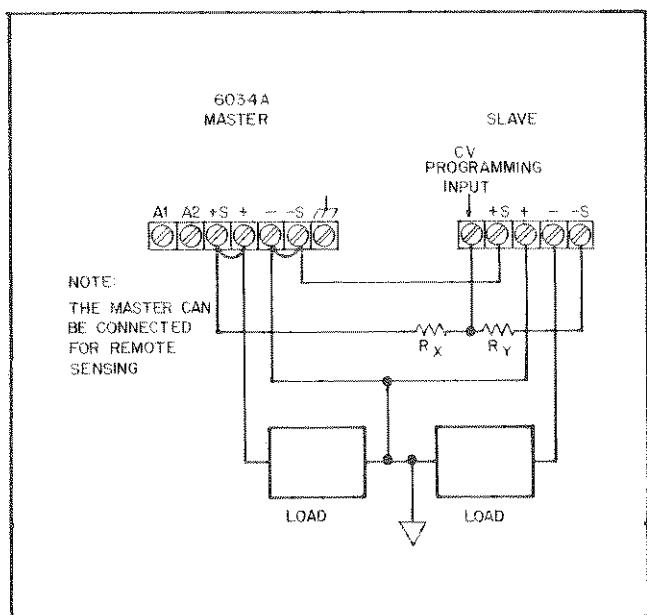

Figure 3-8. Auto-Series Operation. Positive and Negative Outputs

3-44 **Setting Output Voltage and Current.** The auto-series combination of supplies behaves as if it were a single constant voltage/constant current supply controlled by the voltage and current settings of the master supply. The voltage controls of the slave supplies must be disabled. On Hewlett-Packard autoranging supplies this is accomplished by removing the straps that connect the CV Current Source Output and VOLTAGE potentiometer terminals to the CV Programming Voltage Input terminal. The current controls of the slave supplies should be set above the desired output current to avoid interference with the master supply.

**NOTE**

*The current controls of Hewlett-Packard autoranging supplies can be disabled by replacing the strap connected between the CC Programming Voltage terminal and the CURRENT potentiometer terminal with a resistor on each slave supply. The resistor value should be chosen to program a current greater than the desired output current. The Operating and Service Manuals for Hewlett-Packard autoranging supplies provide instructions for selecting the resistor value.*

3-45 **Resistor Values.** As shown, each slave has an external voltage divider,  $R_X$  and  $R_Y$ , that determines its programming voltage. The ratio of  $R_Y$  to  $R_X$  determines the ratio of the slave output voltage to the master output voltage. To determine the values of  $R_Y$  and  $R_X$ , first choose the ratio of the slave output voltage to the master output voltage ( $\frac{V_m}{V_s}$ ), select a value for  $R_Y$ , and then determine the value for  $R_X$  by solving this equation:  $R_X = \left[ 12(R_Y) \left( 1 + \frac{V_m}{V_s} \right) \right] - R_Y$ . For example, assume a two-supply combination that is to provide 90 volts, 50 volts from the master and 40 volts from the slave. If we select a value of 1k for  $R_Y$ , the equation becomes:

$$R_X = \left[ 12(1000) \left( 1 + \frac{50}{40} \right) \right] - 1000$$

$$R_X = \left[ 12,000 (2.25) \right] - 1000$$

$$R_X = 26,000$$

3-46 Note that the slave output voltage may be lower than, equal to, or higher than the master output voltage.

3-47 Two factors must be considered when selecting the resistance value of  $R_Y$ ; the effect on programming specifications, particularly speed, and the power that the resistor will have to dissipate. In the previous example, with a total resistance of 27k across an output of 90 volts,  $R_X$  will have to dissipate 290 milliwatts and  $R_Y$  will have to dissipate slightly more than 11 milliwatts. Lower resistance values of  $R_X$  and  $R_Y$  will increase programming speed while increasing the amount of power that  $R_X$  and  $R_Y$  will have to dissipate.

3-48 To maintain the temperature coefficient and stability specifications of the supplies,  $R_X$  and  $R_Y$  must be stable, low-noise resistors with temperature coefficient of less than 25 ppm per °C and power ratings of at least 30 times what they will actually dissipate.

3-49 The front-panel VOLTAGE potentiometer of the slave supply can be used in place of  $R_Y$  by connecting a strap from the CV Programming Voltage Input terminal of the slave supply to the VOLTAGE potentiometer terminal of the slave supply. This enables the user to vary the percentage of the total voltage contributed by the slave.

**3-50 Overvoltage Protection in Auto-Series.** Adjust the OVP trip point in each supply to a voltage higher than the voltage that supply will contribute. If the master supply OVP trips, the master supply will program the slave supplies to zero output. If a slave supply OVP trips, that slave supply and all slave supplies between it and the negative end of the series will go to zero output; all units more positive than the tripped slave supply (which includes the master supply) will continue to supply their set output voltage. Therefore, the total output voltage of the auto-series combination will be the sum of the outputs from the master supply plus any slave supplies between the master supply and the tripped slave supply. For maximum protection against overvoltage, set each unit's OVP slightly higher ( $\approx 1.5$  volts) than the voltage it will contribute. For maximum protection against false tripping, set the slave supply OVPs to maximum and adjust OVP at the master.

**3-51 Auto-Series with Remote Voltage Sensing.** To combine auto-series operation with remote voltage sensing, connect the supplies as described above but remove the +S jumper from the master supply and the -S jumper from the most negative supply, and connect the +S and -S terminals directly to the + and - ends of the load. Observe the precautions outlined under Paragraph 3-30.

**3-52 Auto-Tracking Operation**

3-53 Figure 3-9 shows the interconnections required to operate two or more units in auto-tracking mode with a 6034A as the master supply. This mode of operation allows multiple supplies that share a common output bus (negative or positive) to power separate loads and have their output voltages simultaneously programmed by the voltage and cur-

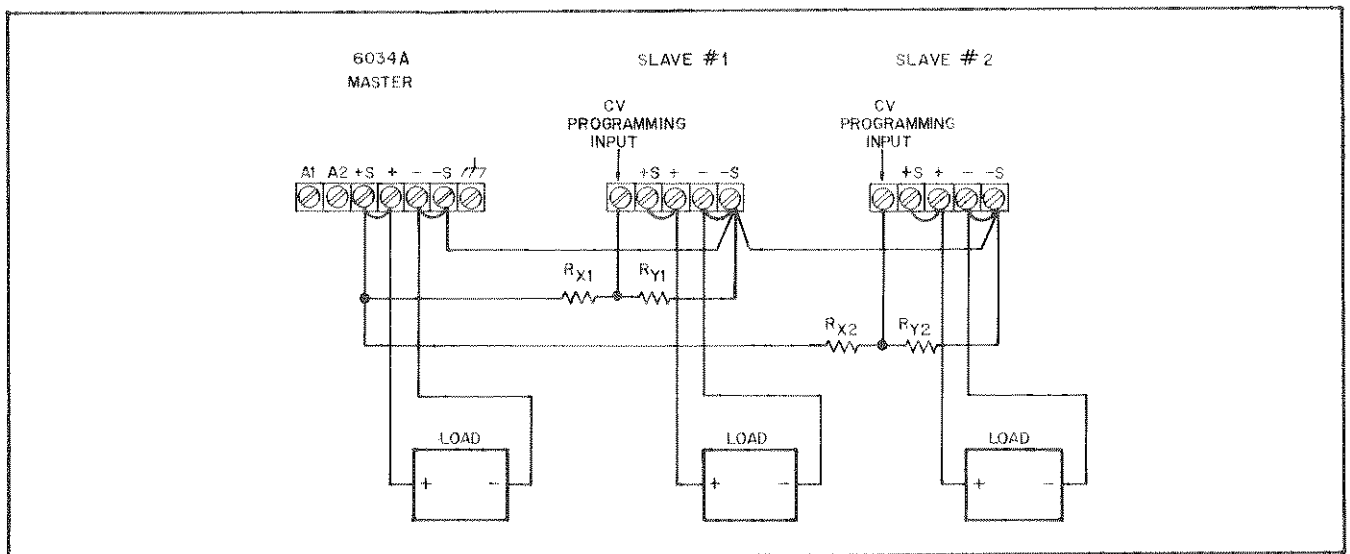

Figure 3-9. Auto-Tracking Operation

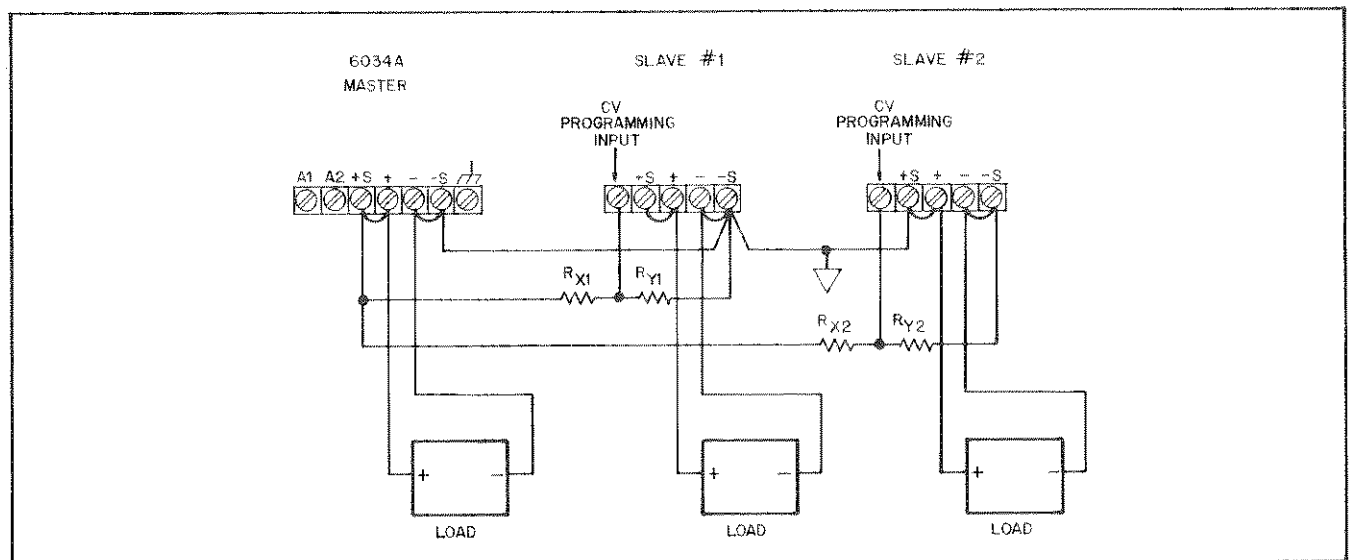

Figure 3-10. Auto-Tracking Operation, Positive and Negative Outputs

rent settings of the master supply. The output voltage of each slave supply varies in direct proportion to that of the master supply. The ratio of each slave supply's output voltage to the master supply's is established by the ratio of the resistors in the voltage divider connected between + S of the master supply and - S of the slave supply.

**3-54** Figure 3-10 shows the interconnections required to provide both positive and negative outputs from an auto-tracking combination. As can be seen, the only difference from standard auto-tracking operation is that the + Out terminal of slave #2 instead of the - Out terminal is connected to the common bus. There is no limit to the number of supplies that can be operated in either auto-tracking configuration, but the 6034A must be the master supply.

**3-55 Resistor Values.** The method for determining the values of  $R_X$  and  $R_Y$  in Figure 3-9 is similar to that given in Paragraph 3-45 for auto-series mode. First choose the ratio of the slave output voltage to the master output voltage, select a value for  $R_Y$ , and then determine the value for  $R_X$  by solving the equation:

$$R_X = R_Y \left[ \left( 12 \frac{V_m}{V_s} \right) - 1 \right]$$

**3-56** For example, assume a two-supply configuration in which the slave output is to vary from 0 to 50 volts while the master output varies from 0 to 30 volts. If we select a value of 1k for  $R_Y$ , the equation becomes:

$$R_X = 1000 \left[ \left( 12 \frac{30}{50} \right) - 1 \right]$$

$$R_X = 1000 [7.2 - 1]$$

$$R_X = 6200$$

**3-57** The same factors that govern the choice of  $R_Y$  in auto-series mode apply in auto-tracking mode.

**3-58** Repeat the process for each slave, with each slave referenced to the same (master) supply (unlike auto-series mode). Note that the slave output voltage may be lower than, equal to, or higher than the master output voltage.

**3-59** For auto-tracking operation with both positive and negative outputs, as shown in Figure 3-10, the equation in Paragraph 3-55 is used to determine the values of  $R_X$  and  $R_Y$  for the slaves providing positive outputs, and the equation in Paragraph 3-45 is used to determine the values of  $R_X$  and  $R_Y$  for the slaves providing negative outputs.

**3-60** To maintain the temperature coefficient and stability specifications of the supplies,  $R_X$  and  $R_Y$  must be stable, low-noise resistors with temperature coefficients of less than 25 ppm per °C and power ratings at least 30 times what they will actually dissipate.

**3-61** The front-panel VOLTAGE potentiometer of the slave supply can be used in place of  $R_Y$  by connecting a strap from the CV Programming Voltage terminal of the slave supply to the VOLTAGE potentiometer terminal of the slave supply. This enables the user to vary the ratio of the slave supply output voltage to the master supply output voltage.

**3-62 Setting the Current Controls.** The current controls of all supplies in an auto-tracking combination are independently operative and can be used to set current limits for each individual load. If the master supply goes into constant current mode, the output voltages of the slave supplies continue to track the output voltage of the master supply. If a slave supply goes into constant current mode, however, no other supply is affected.

**3-63 Overvoltage Protection in Auto-Tracking.** Adjust the OVP trip point of each supply as appropriate for the load connected to that supply. If the master supply OVP trips, the master supply will program the slave supplies to zero output. If a slave supply OVP trips, only that slave supply and its load will be affected.

**3-64 Auto-Tracking with Remote Voltage Sensing.** To combine auto-tracking operation with remote voltage sensing, connect the supplies as described above but remove the + S and - S jumpers from each supply and connect the + S and - S terminals directly to the + and - ends of its load. Observe the precautions outlined under Paragraph 3-30.

### 3-65 HP-IB

**3-66** Connections between the 6034A and the HP-IB are made via the HP-IB connector on the rear panel. Figure 3-11 shows the signals at each of the HP-IB connector pins. The HP-IB connectors table in Section I lists cables and cable accessories that are available from HP. The 6034A HP-IB connector uses metric threads, which are colored black. Cables manufactured prior to 1975 have non-metric fasteners, which are colored silver. Do not attempt to mate non-metric (silver) fasteners with metric (black) fasteners (see accessories table for conversion kit).

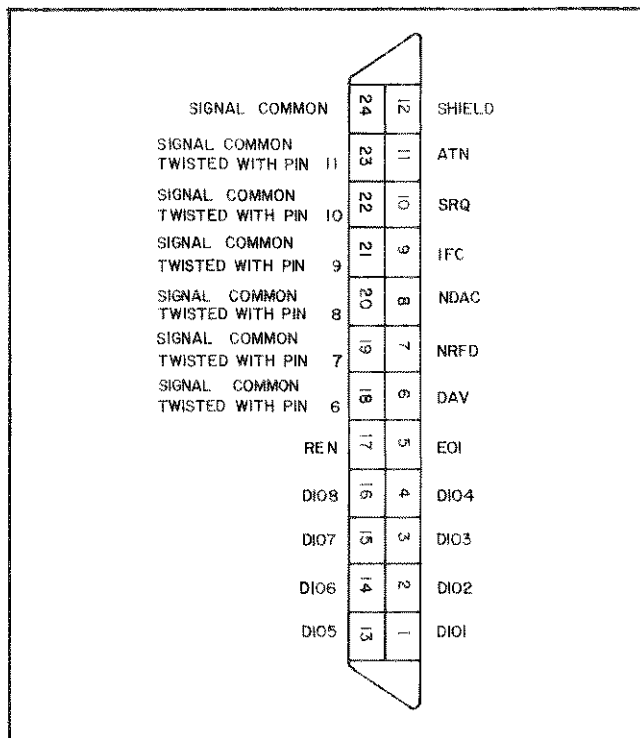

Figure 3-11. HP-IB Connector

3-67 An HP-IB system may be connected together in any configuration (star, linear, or combination) as long as the following rules are followed:

1. The total number of devices is no more than 15.
2. The total length of all the cables used is no more than two metres times the number of devices connected together, up to an absolute maximum of 20 metres. (The length between adjacent devices is not critical as long as the total accumulated cable length is no more than the maximum allowed.)

#### NOTE

*IEEE Std 488-1978 states that caution should be taken if individual cable length exceeds 4 m.*

3-68 It is recommended that no more than three connector blocks be stacked together, as the resultant leverage can exert excessive force on the mounting panels. Be certain that all connectors are fully seated and that the lock screws are firmly finger tightened. Do not use a screwdriver. The screwdriver slots in the lock screws are provided for removal purposes only.

3-69 Paragraph 3-82 provides information for operating the 6034A in an HP-IB system. The Tutorial Description of the Hewlett-Packard Interface Bus and other documents listed in Section I provide additional information that may be helpful when designing an HP-IB system.

### 3-70 Current-Monitor Output Signal

3-71 An amplified and buffered output signal from the current-monitoring resistor is available between terminals A1 and A2 on the rear panel. This signal can be connected to a remote voltmeter to indicate the amount of output current. The signal varies from 0 to 5 volts to indicate a zero to full scale (10A) current output. The - terminal of the voltmeter should be connected to terminal A2. Output impedance at terminal A1 is 10k; a load of 1 megohm will maintain 1% reading accuracy.

### 3-72 Protective Circuits

3-73 Protective circuits within the 6034A may limit or turn off the output in case of abnormal conditions. The cause for the protective action can be determined by observing the front-panel indicators (lights and meters). An overrange condition is indicated by the UNREGULATED indicator on, the VOLTS and AMPS meters reading relatively high, and the MODE indicators off. An overvoltage condition is indicated by the OVP indicator on, both meters reading near zero, and the MODE indicators off. An overtemperature condition is indicated by the OTP indicator on, the MODE indicators off, and both meters dropping to near zero from the readings that existed when the overtemperature condition occurred. If the 6034A receives an invalid request via HP-IB (eg: syntax error or out of range), the INVALID REQUEST indicator turns on; the unit ignores the invalid request and remains at the previously set value. If the primary power voltage drops below approximately 70% of nominal, the level detector will turn off the output. In this case, the UNREGULATED indicator is on, the MODE indicators are off, and both meters read zero (the supply will probably reset).

## 3-74 LOCAL OPERATION

3-75 The 6034A is configured for local operation (RMT indicator off) and constant voltage mode (CV (NORMAL) indicator on) when the unit is turned on. Output voltage is set to zero, output current is set to 1 ampere, and the OUTPUT ADJUST knob is configured to adjust output voltage (VOLTAGE indicator is on). Pressing the OUTPUT ADJUST pushbutton switch alternately configures the OUTPUT ADJUST knob to adjust output voltage and output current, as indicated by the VOLTAGE and CURRENT indicators. Note that the OUTPUT ADJUST knob will vary whichever output parameter, voltage or current, is indicated by the VOLTAGE and CURRENT indicators, even when the other parameter is limiting the output. For example, assume the voltage limit is set to 50 V but the unit is in constant current mode with a 25 V output. Rotating the OUTPUT ADJUST knob when the VOLTAGE indicator is on will vary the 50 V limit, even though the voltmeter will not change until (and if) the voltage limit is adjusted below 25 V. When the 6034A is under remote control (RMT indicator on), neither the VOLTAGE or CURRENT indicator is on and the OUTPUT ADJUST knob has no effect.

### 3-76 Constant Voltage Operation

3-77 To adjust the supply for constant voltage operation:

- a. With supply turned off, connect load to output terminals, and connect a short across load.
- b. Turn on supply. Press OUTPUT ADJUST pushbutton once so that OUTPUT ADJUST knob controls current, and adjust for the desired maximum output current. (It may be necessary to turn up voltage setting slightly.)
- c. Press OUTPUT ADJUST pushbutton once so that OUTPUT ADJUST knob controls voltage, and adjust voltage to zero.
- d. Remove short from load, and rotate OUTPUT ADJUST knob for desired output voltage.
- e. If a load change causes the current limit to be exceeded, the supply automatically crosses over to constant current operation and the output voltage drops proportionately. In setting the current limit, make an adequate allowance for high current peaks that could cause unwanted mode crossover.

### 3-78 Constant Current Operation

3-79 To adjust the voltage limit in constant current mode, a load resistor is used in place of the actual load. The resistance value of the load resistor must be chosen to permit no more than 1A to flow at the desired voltage. Use Ohm's Law,  $R = E/I$ , to determine the minimum resistance value that can be used ( $E =$  desired voltage limit,  $I = 1A$  or less.) Any larger value is acceptable, but see **WARNING** following step b. Be certain that the power rating of the load resistor is adequate. For example, assume that a limit of 60 V is to be set. A 60-ohm resistor will draw 1A at 60 V, and will have to dissipate 60 W. A 120-ohm resistor will draw 0.5A, and will have to dissipate only 30 W. To adjust the supply for constant current operation:

- a. With supply turned off, connect load resistor, turn power on, and rotate OUTPUT ADJUST knob for the desired maximum output voltage.

b. Press OUTPUT ADJUST pushbutton switch once, so that OUTPUT ADJUST knob controls current (CURRENT indicator on). Turn output current down to zero. (Turn OUTPUT ADJUST knob CCW at least one turn after AMPS meter indicates zero to account for calibration tolerance.) 6034A should be in CC (LIMIT) mode with output voltage approximately zero.

**WARNING**

*With worst-case calibration, the load resistor may have to pass up to 20 mA while output current is adjusted to zero. Therefore, the larger the resistance the greater may be the voltage developed across the load resistor. (For example, 250  $\Omega$  may develop up to 5 V, 1 k $\Omega$  may develop up to 20 V.)*

c. Connect actual load to 6034A output terminals and then disconnect load resistor.

**WARNING**

*Depending on calibration of unit, output voltage may begin to rise slowly if no load is connected to the output terminals. Be certain to connect load before disconnecting load resistor. VOLTS meter will indicate voltage at the output terminals. If the output voltage begins to rise, turn power off and start procedure again.*

d. Rotate OUTPUT ADJUST knob for the desired output current.

e. If the load change causes the voltage limit to be exceeded, the supply automatically crosses over to constant voltage operation and the output current drops proportionately. In setting the voltage limit, make an adequate allowance for high peak voltages that could cause unwanted crossover.

### 3-80 Return to Local

3-81 If the 6034A is under remote control (RMT indicator on) and local lockout has not been sent (see Paragraph 3-97), pressing the LCL pushbutton switch will return the unit to local (front panel) control. Holding the LCL switch in will prevent the 6034A from returning to remote control for as long as the LCL switch is held in or until local lockout is sent. If the 6034A has been disabled via HP-IB (DISABLED indicator on), the LCL switch will not restore the 6034A output. The only way to eliminate disable locally is to turn the 6034A power off and then back on. However, the OUTPUT ADJUST controls continue to operate in local control even if the unit is disabled.

### 3-82 HP-IB OPERATION

#### 3-83 Interface Functions

3-84 The 6034A implements the following HP-IB interface

functions, which are defined by IEEE standard 488:

SH1 (Source Handshake)  
AH1 (Acceptor Handshake)  
T1 (Talker)  
L1 (Listener)  
SR1 (Service Request)  
RL1 (Remote Local)  
PP1 (Parallel Poll)  
DC1 (Device Clear)  
DT1 (Device Trigger)

3-85 **Multiline Message Control Functions.** The Acceptor Handshake, Source Handshake, Listener, and Talker functions are ordinarily implemented by the interface circuits of the 6034A and the controller, and require no action by the user. The LSN or TLK indicators turn on when the 6034A is addressed to be a listener or talker. (The talker function includes serial poll, see Paragraph 3-89.)

3-86 **Service Request.** Service Request is a uniline message asserted by the 6034A at power on, and for certain other events as selected by the user. These are: Invalid Request, Overtemperature, Limit Mode, Overvoltage, and Unregulated. The 6034A powers on with service request (interrupt) capability for these five events masked, i.e., none of them can cause the 6034A to request service. This does not affect the condition(s) within the 6034A, nor does it affect the power supply status indicators; the mask simply prevents the 6034A from requesting service for the masked condition. Also, even if an interrupt is masked the 6034A will respond to a serial poll with the present state of the unit (see Paragraph 3-89). Paragraphs 3-103 and 3-110 provide instructions for unmasking service request (interrupt) capability.

3-87 The SRQ indicator turns on whenever the 6034A is requesting service from the controller, and remains on until the controller conducts a serial poll (will remain on after poll if fault remains).

3-88 Service requests for unregulated operation and limit mode can be delayed if desired for up to 65 seconds after a new output value is programmed or unit is reset. The delay can prevent service requests for temporary conditions. For example, if the output voltage is programmed to rise from 5 V to 60 V, the output may be unregulated while the output voltage is rising. Ordinarily, this would not be cause for concern, and a service request for this temporary condition would be an annoyance. Factors that influence how long the unregulated or limit mode condition will last include: difference between old output value and new output value, limit value, and output (load) capacitance (for CV mode) or output inductance (for CC mode). The length of delay required must be determined empirically; the programming-response-time graphs in the specifications table, Section I, can be used as guidelines. The 6034A powers on with a delay value of 500 ms. Paragraphs 3-103 and 3-108 provide instructions for programming delay time.



Table 3-2. Status-Byte Bit Descriptions

DIO Line #	Decimal Weight	Description	Bit Reset By	Can Request Service?	SRQ Can Be Masked?	SRQ Can Be Delayed?	Front-Panel Indicator
1	1	OVERTEMPERATURE-Set when an over-temperature condition causes shutdown of output.	Either: 1. OT fault ceases and SRQ was not set (for any fault), or 2. Serial poll, if OT fault ceased after SRQ (for any fault).	Yes	Yes <sup>①</sup>	No	OTP indicates present state of OT circuit, not OT bit.
2	2	UNREGULATED-Set when output is unregulated either because load tries to draw excess power or because of low input power.	Either: 1. Unregulated fault ceases and SRQ was not set (for any fault), or 2. Serial poll, if unregulated fault ceased after SRQ (for any fault).	Yes	Yes	Yes	UNREGULATED indicates present state of power supply output, not UNREGULATED bit.
3	4	OVERVOLTAGE-Set when OVP circuit trips.	Either: 1. Reset of OVP circuit if SRQ was to set (for any fault), or 2. Serial poll, if OVP circuit is reset after SRQ (for any fault). <sup>②</sup>	Yes	Yes <sup>①</sup>	No	OVP indicates present state of OVP circuit, not OVP bit.
4	8	LIMIT MODE-Set when either: 1. Unit is programmed as a voltage source (M1) but switches to constant current operation, or 2. Unit is programmed as a current source (M2) but switches to constant voltage operation.	Either: 1. Limit mode operation ceases and SRQ was not set (for any fault), or 2. Serial poll, if limit mode operation ceases after SRQ (for any fault).	Yes	Yes	Yes	MODE indicators indicate present state of power supply, not LIMIT bit.
5	16	DISABLE-Set when unit is disabled upon receipt of either an "S" or Device Clear command.	Power supply reenabled upon receipt of an "R".	No	—	—	DISABLED indicates the state of the DISABLED bit.
6	32	INVALID REQUEST-Set upon receipt of an invalid request (syntax error or out of limits).	Serial poll.	Yes	Yes	No	INVALID REQUEST indicates the state of the INVALID REQUEST bit.
7	64	REQUEST SERVICE-set when 6034A requests service, indicates if unit was requesting service when polled.	Serial poll (if fault has been corrected).	—	—	—	SRQ indicates the state of the REQUEST SERVICE bit.
8	128	POWER ON-set when unit initializes at power on.	Serial poll.	Yes	No	No	—

Notes:

- 1 Masking Overtemperature or OVP does not prevent shutdown of output in case of overtemperature or OVP condition.
- 2 Serial poll does not reset OVP circuit, just the OVP bit.

**3-89 Serial Poll.** In a serial poll, the controller polls each device on the bus, one at a time. The 6034A responds with an eight-bit status byte on the data lines. Table 3-2 defines each of the bits, indicating what causes each to be set and reset, and the state of the corresponding front-panel indicator. Note that the status byte represents only the 6034A, not other power supplies that may be slaved to the 6034A in an auto-parallel, auto-series, or auto-tracking configuration. The response of the 6034A to a serial poll depends on whether or not the unit had been requesting service when the serial poll occurred.

3-90 If the 6034A is requesting service (SRQ on) for any reason other than power on, OVP, OTP, unregulated, invalid request, and limit mode faults will accumulate in the status byte until a serial poll, regardless of whether they were masked or not and regardless of whether that fault still exists. For example, assume the following sequence:

1. Limit mode is masked (unable to cause a service request).
2. Invalid request is unmasked (able to cause a service request).
3. 6034A receives an invalid request (syntax error or out of limit). SRQ will be set.
4. 6034A switches to limit mode and then switches back to normal mode.
5. Controller conducts a serial poll. The 6034A status byte will have bits set for both invalid request and limit mode, even though the unit is not operating in limit mode when the serial poll is conducted.

3-91 If the 6034A is not requesting service when a serial poll occurs, the status byte indicates the present state of the unit.

3-92 Power on (PON) always requests service. Therefore, if a momentary power dropout causes the 6034A memory to lose its programmed values, PON alerts the user that the 6034A has been initialized (see Paragraph 3-105). The 6034A also requests service when it loses ac power.

3-93 If the unit fails self test at power on, it will not respond to a serial poll (even though unit will have set SRQ). The user should include a time-out in his program after which the controller will not wait for the 6034A to respond to a serial poll. If the time-out occurs, the 6034A can be assumed to be malfunctioning and should be removed for service.

**3-94 Parallel Poll.** Parallel poll allows the controller to determine quickly which of a number of instruments on the bus requested service. The parallel poll response corresponds to bit 7 of a serial poll status byte (see Table 3-2). Parallel poll does not reset service request in the 6034A. The 6034A can be configured remotely from the controller, or it can be configured locally.

3-95 Unless configured remotely, the 6034A responds to a parallel poll with a "1" on one of the DIO lines (if requesting service), as determined by the setting of its address switches. Addresses 7 through 0 correspond to DIO lines 1 through 8 (decimal weight  $2^0$  through  $2^7$ ). If the 6034A address switches are set to 8 or higher, the 6034A will not respond to a parallel poll unless the unit is configured remotely. The 6034A cannot return a "0" to indicate it was requesting service unless it has been configured remotely.

3-96 The 6034A can be configured remotely to respond to a parallel poll with either a "1" or a "0" on one of the DIO lines if the unit is requesting service. Configuration statements with a decimal value of 0 through 7 will configure the unit to respond with a "0" on one of DIO lines 1 through 8; decimal values of 8 through 15 configure the unit to respond with a "1" on one of DIO lines 1 through 8. By configuring the 6034A remotely, the 6034A address switches may be set to any address from 0 through 30 without affecting the parallel poll response. The capability to configure either a "0" or "1" response allows the user to AND or OR two or more instruments on one DIO line.

**3-97 Remote Local.** The remote local function allows the 6034A to operate in either local (front panel) or remote (via HP-IB) control. The user can send Local Lockout to the 6034A via HP-IB to disable the front-panel LCL switch only. With Local Lockout, the controller determines if the unit operates in local or remote control; this enables the controller to prevent anyone from returning the 6034A to local control.

**3-98 Device Clear.** Device Clear is implemented in the 6034A as Set (see Paragraph 3-124). The two differences between Set and Device Clear are: Device Clear can be an unaddressed or addressed command, and the 6034A will implement Device Clear regardless of whether the unit is in local or remote control. Device Clear is typically used in systems to send all devices in the system to a known state with a single command (which could be generated by a "panic" button).

**3-99 Device Trigger.** Device Trigger is implemented in the 6034A as Go (see Paragraph 3-128). Each device that is to respond to Device Trigger must be addressed, and the 6034A will not implement Device Trigger in local control. Device Trigger is typically used in systems to synchronize the operation of a number of addressed devices.

### 3-100 HP-IB Address Selection

3-101 The HP-IB address switches are located on the rear panel. Figure 3-12 shows the factory-set address of "5" (binary 00101). Any address from 00 through 30 (decimal) is a valid HP-IB address. The 6034A will operate on whatever address is set on the address switches.

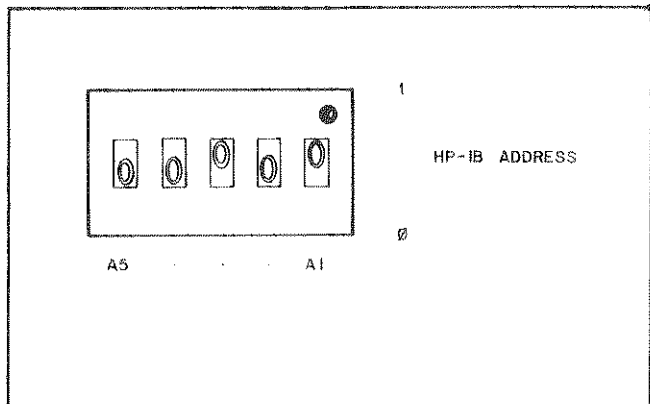

Figure 3-12. HP-IB Address Switches

3-102 Note that some instruments (not the 6034A) will initialize at a particular address although they can be programmed subsequently to respond to a different address. If the system includes instruments with this characteristic and they are programmed for addresses other than their initialized address, a momentary input power dropout may cause them to re-initialize their address. If another instrument, such as a 6034A, is hardware set to that address, the system will not function properly. Therefore, the system program should be written to monitor any re-initialization and reset any programmed data, such as addresses, that may have been lost.

### 3-103 Programming Syntax

3-104 Figure 3-13 shows a full programming string for the 6034A power supply. Paragraphs 3-106 through 3-131 describe each of the commands in the programming string. The letters used to program each of the commands are printed in boldface type in the following paragraphs. When referring to Figure 3-13, it should be remembered that:

1. The spaces shown between commands are for clarity of the illustration, they are not required (but they may be used, as may be commas).
2. Commands may be sent in any order (e.g., current may be sent before voltage). However, only commands received by the 6034A before a **G**, **R**, or Device Trigger (DT) command will be implemented by that **G**, **R**, or DT.

Therefore, for example, if **G** is sent before the voltage, that voltage will be stored in, but not implemented by, the 6034A until receipt of another **G**, **R**, or DT.

3. It is not necessary to send an entire string. If only the output voltage is to be changed, that is the only value that need be sent to the 6034A.
4. Each command must be completed before another is entered. For example, if you enter **P** you must enter a **V** to complete that command before entering any other command. Otherwise, the 6034A will consider the incomplete command an invalid request. Subsequent complete commands will be accepted.
5. Numbers will be rounded off by the 6034A to the best resolution of the 6034A output. Leading and trailing zeroes will be ignored.

6. Numbers that are not within the ranges listed in Figure 3-13 will invalidate the command.
7. Values for mode, potential, current and overvoltage trip level (a function of soft voltage limit) are stored in, but not implemented by, the 6034A until receipt of a **G** or DT command. Note that any subsequent value received by the 6034A prior to receipt of a **G** or DT command will supersede the stored value. Values will remain stored even if the 6034A is switched to local and then back to remote control.

3-105 **Initial Conditions.** The 6034A initializes at power on with the following values programmed:

output voltage = 0 volts  
 output current = 1 ampere (local)  
                                   0 ampere (remote)  
 mode = M1 (voltage source)  
 delay = 500 milliseconds  
 interrupt mask = N8 (all masked except power on)  
 soft voltage limit = 60 volts (OVP trip level = 64.5 V)  
 soft current limit = 10 amperes

3-106 **Mode.** Mode designates the 6034A as either a voltage source (M1) or a current source (M2). If not masked, the 6034A will request service if:

1. The unit switches to constant current while operating in M1, or
2. The unit switches to constant voltage while operating in M2.

3-107 Either 1 or 2 must be sent after **M** to complete the command. Mode will be stored in, by not implemented by, the 6034A until receipt of a **G** or DT command. The 6034A initializes as a voltage source (M1).

3-108 **Delay.** Delay operates to prevent service requests for either limit mode or unregulated operation for a specific period after a new output value is programmed. This serves to eliminate nuisance service requests for temporary conditions that may exist while the 6034A output is changing to a new

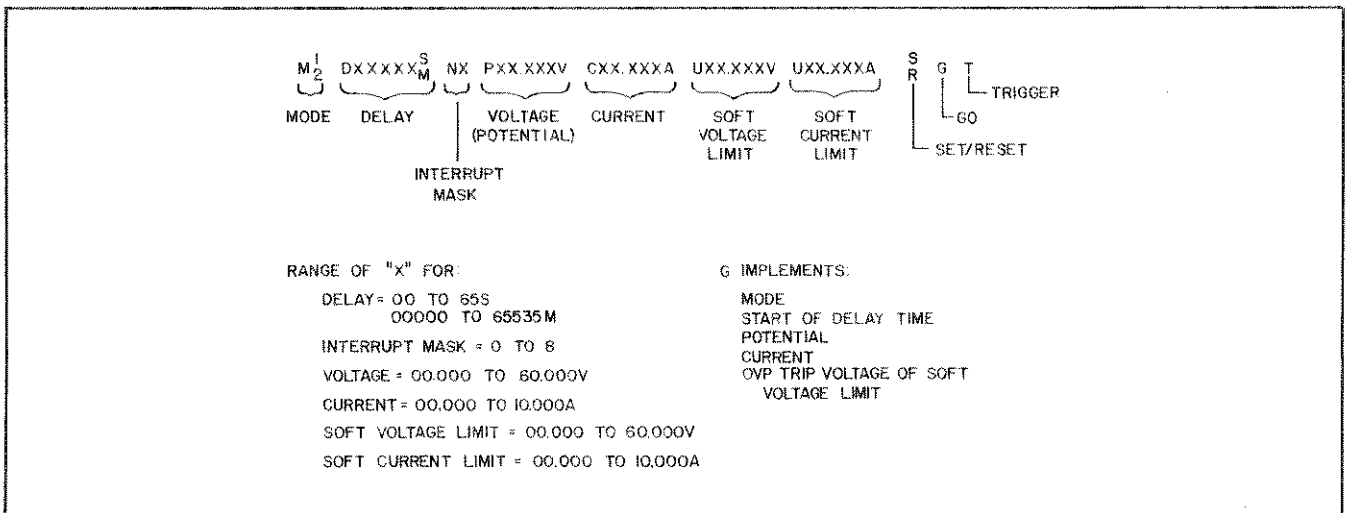

Figure 3-13. Programming Syntax

value. The delay time starts upon receipt of a **G**, **DT**, or **R** command (Go, Device Trigger, or Reset; see Paragraphs 3-128, 3-99, and 3-124). If either limit mode or unregulated operation continues beyond the delay time, or if either occurs any time after the delay time has elapsed, a service request will occur immediately (if unmasked).

**3-109** Delay may be set from 0 to 65 seconds (**S**), or 0 to 65535 milliseconds (**M**). Either **S** or **M** must be sent after **D** to complete the command. The 6034A initializes with a 500 millisecond delay.

**3-110** **I**nterrupt Mask. The 6034A powers on with no service request capability except for power on. Overtemperature, invalid request, limit mode, overvoltage, and unregulated conditions can be unmasked to enable the 6034A to request service if they occur. Programming any value of **N** from 0 through 7 un.masks both overtemperature and invalid request. Table 3-3 shows which of the other conditions will also be unmasked for each value of **N** from 0 through 7. As can be seen, **N0** un.masks the full service request capability. Any digit from 0 through 8 must be sent after **N** to complete the command. The 6034A initializes with an interrupt mask value of 8 (all masked except power on).

Table 3-3. Interrupt Masks

Fault N	Unregulated	Overvoltage	Limit Mode
0	0	0	0
1	0	0	1
2	0	1	0
3	0	1	1
4	1	0	0
5	1	0	1
6	1	1	0
7	1	1	1

0 = Unmasked (able to request service)  
1 = Masked (unable to request service)

Overtemperature and invalid request are unmasked for any value of **N** from 0 through 7.

**N8** masks all interrupts (service requests) except power on.

**3-111** **P**otential (Voltage). Potential programs the output voltage of the 6034A, from 0 to 60.000 volts. Any number of digits may be sent, but the 6034A will use only five. A decimal point must be sent if needed, but may be left out if not needed (e.g., **P10V** and **P10.0V** are both valid requests and will produce the same result).

**3-112** Potential will be stored in, but not implemented by, the 6034A until receipt of a **G** or **DT** command. Therefore, it is possible to send two values to the 6034A in one string, such as **P18V G P5V**. The 6034A output will go to 18 volts immediately upon receipt of the **G** and will go to 5 volts only upon subsequent receipt of a **G** or **DT** command. Note that any subsequent potential value received by the 6034A prior to receipt of a **G** or **DT** command will supersede the 5 V value.

**3-113** If the 6034A receives an invalid request (value out of range or greater than the soft voltage limit), the 6034A output will remain at its present value.

**3-114** A **V** must be sent after **P** to complete the command. The 6034A initializes at 0 volts output.

**3-115** **C**urrent. Current programs the output current of the 6034A, from 0 to 10.000 amperes. Factors described in the preceding paragraphs for potential apply also to current.

**3-116** An **A** must be sent after **C** to complete the command. The 6034A initializes at 0 amperes output for remote control, 1 ampere output for local control.

**3-117** **S**oft Voltage Limit (Upper Value). Soft voltage limit sets the maximum output voltage to which the output can be programmed (either in remote or local control), and it also determines the remotely programmed OVP trip level ( $2\text{ V} + 1.04 \times \text{soft limit voltage}$ ). Soft limit protects the load in situations in which a damaging output voltage is inadvertently programmed. For example, assume that the output voltage to be programmed is determined by a series of measurements and computations. An unexpected measurement and/or combination of inputs to the computation could result in an unacceptably high output voltage. However, if the programmed voltage exceeds the soft voltage limit, the 6034A will consider the new value an invalid request and the 6034A output will remain at the previous value.

**3-118** The soft voltage limit value is compared to all incoming values for output voltage. If the incoming value passes the comparison, it is stored in the 6034A. Therefore, if a voltage value is sent to the 6034A but not implemented by a **G** or **DT** command, that voltage will not be affected by any subsequently received soft limit value. Note, however, that if the stored voltage value exceeds the new OVP trip voltage, the OVP circuit will trip whenever the 6034A receives a **G** or **DT** command. It is good practice to program soft limit values first, before programming the output.

**3-119** A consequence of not setting limits first that may not be obvious to the user arises from the fact that the 6034A can store a new output value that is different from the present output. If the 6034A receives a soft voltage limit that is lower than the present output voltage, the output will remain unchanged. However, if the unit is switched to local control and **OUTPUT ADJUST** is set to **VOLTAGE**, the output will drop to the new soft voltage limit. If the 6034A then receives a **G** or **DT** command, the output will return to its last remotely programmed value. Note that the new OVP trip voltage ( $2\text{ V} + 1.04 \times \text{soft voltage limit}$ ) is implemented immediately upon receipt of a **G** or **DT** command or when the unit is switched to local control. If this OVP trip voltage is lower than the output voltage, OVP will trip. As an example, assume the following sequence:

1. Output voltage is 20 V.
2. User programs a soft voltage limit of 18 V, but does not send a **G** or **DT** command. Output remains at 20 V.
3. User presses **LCL** switch (**OUTPUT ADJUST** in **VOLTAGE**). 6034A output will go to 18 V, because locally programmed value is continually compared to soft voltage limit.
4. 6034A receives a **G** or **DT** command. Output will return to 20 V, because 20 V value was compared and stored before 18 V soft voltage limit was received.

5. User programs a soft voltage limit of 15 V, but does not send a **G** or **DT** command. Output remains at 20 V.
6. User presses LCL switch. OVP circuit will trip and output drop to 0 volts, because output exceeds 17.6 V OVP trip voltage.
7. 6034A receives an **R** (reset) command. Output goes to 15 V, the soft voltage limit.
8. 6034A receives a **G** or **DT** command. OVP circuit will trip, because the remotely stored value of 20 V exceeds the 17.6 V OVP trip voltage.
9. 6034A receives an **R** command. Output remains at 0 volts because 6034A attempts to go to 20 V output, and OVP trips again.

3-120 Being careful to set limits first before programming the output will eliminate the possibility of the preceding situation.

3-121 A **V** must be sent after **U** to complete the command. The 6034A initializes at 60.000 V soft voltage limit (64.5 V OVP trip voltage). Remember that the OVP circuit will trip at the lower trip voltage, either locally or remotely set, regardless of whether the 6034A is in local or remote control.

3-122 **Soft Current Limit (Upper Value)**. Soft current limit sets the maximum output current to which the output can be programmed (either in remote or local control). Factors described in the preceding paragraphs for soft voltage limit apply also to soft current limit, except that soft current limit does not include overcurrent protection. Also, if the 6034A is switched to local control, the output is affected by soft current limit when **OUTPUT ADJUST** is set to **CURRENT**.

3-123 An **A** must be sent after **U** to complete the command. The 6034A initializes at 10.000A soft current limit.

3-124 **Set Reset**. Set disables the output of the 6034A and programs it to 0 volts. The **DISABLED** indicator turns on, but the 6034A remains able to receive and store commands. Reset reenables the 6034A output, and resets the OVP circuit if it tripped. Reset also starts the delay time and implements commands that may have been received while the 6034A was disabled. For example, assume the following sequence:

1. 6034A output is 40 volts.
2. 6034A receives an **S** command and output drops to approximately 0 volts.
3. 6034A receives a command of **P25VG**.
4. 6034A receives an **R** command. Output goes to 25 volts, not the 40 volt output that existed when the unit was disabled.

3-125 This feature can lessen the time required for the output to settle at the new value, because the internal control circuits are settled before the output is reset.

3-126 It may be necessary for the user to program a wait between a new program value and reset after the OVP circuit trips. Because analog circuit delays are greater than digital delays, the output may try to go to the old value before the new value is implemented, possibly re-tripping OVP. Factors that influence whether the output will exceed the OVP trip voltage before the new output value is implemented include:

difference between old output value and new output value, difference between OVP trip voltage and new output value, and output (load) capacitance. The length of the wait between sending the new value and sending reset must be determined empirically; the programming-response-time graphs in the specifications table, Section I, can be used as guidelines.

3-127 The user's program should also be designed to serial poll the 6034A for status before resetting the 6034A after OVP has tripped. When OVP has tripped, the 6034A output is unregulated. However, the **UNREGULATED** indicator and status-byte bit are not turned on, because the 6034A "knows" that OVP caused the unregulated condition. However, if the 6034A is reset before **SRQ** is cleared by a serial poll, the output will be unregulated while the output is rising. Because OVP no longer exists, the unregulated condition will set the status-byte bit for unregulated operation. If the 6034A is serial polled first and then reset, the unregulated condition that occurs while the output is rising will cause a service request only if the condition continues longer than the delay time.

3-128 **Go**. **Go** causes the 6034A to implement the most recently received values for mode, potential (voltage), current, and OVP trip voltage (determined by soft voltage limit). **Go** also starts the delay time during which unregulated operation or limit mode will not cause a service request.

3-129 **Trigger**. **Trigger** causes the 6034A to read the present value of whichever parameter, voltage or current, is not being regulated, and put that load-dependent value on the **DIO** lines. Figure 3-14 describes each of the entires in the readback format. Note that the **EOI** line on the **HP-IB** is asserted true (low) by the 6034A concurrent with line feed.

```

N V
L A XX.XXX CR LF*
F

```

**N** - The supply was operating normally when measurement was taken.

**L** - The supply was in limit mode when measurement was taken.

**F** - The supply was in a fault mode (overvoltage or unregulated) or disabled when measurement was taken, or no measurement was ever taken.

**V** - Numbers (XX.XXX) represent output volts.

**A** - Numbers (XX.XXX) represent output amperes.

**CR** - Carriage Return

**LF** - Line Feed

\* - **EOI** is asserted true concurrent with line feed.

Figure 3-14. Readback Format

- 3-130 A readback of FV999999 means either:
1. The output is unregulated (neither voltage nor current circuit is regulating), or
  2. No measurement has ever been taken (6034A was addressed to talk without having received a T command).

3-131 Once the 6034A has received a T command and taken a measurement, that value can be read back at any time, even if the output has changed.

## NOTES

*It may be necessary to program a delay between an output current change and readback of output current to allow the current-readback metering*

*circuit to settle. The actual settling time required for a particular output current change must be determined empirically. Maximum settling time for maximum accuracy is 200 ms for a 10A change.*

*The time required for the 6034A to measure the load-dependent parameter is a function of the difference between the programmed value and the actual output value. Therefore, setting the program value closer to the expected operating value may increase system speed. Be careful not to set the program values so close as to cause unwanted crossover between CV and CC modes (see Paragraphs 3-77 and 3-79).*

## Section IV

# PRINCIPLES OF OPERATION

### 4-1 INTRODUCTION

4-2 This section contains block diagrams, simplified schematics, and related descriptions of the 6034A circuits. The 6034A can be thought of as comprising two major sections, the HP-IB and microcomputer circuits, and the power mesh and control circuits. Three block diagrams represent the HP-IB circuits, microcomputer circuits, and front-panel assembly. The descriptions accompanying these block diagrams explain the function of each block without describing how individual components within the circuit accomplish that function. A simplified schematic represents the power mesh and control board. Detailed descriptions are provided only for those individual circuits and components whose operation may not be obvious to the user.

4-3 The circuit names and layouts of the block diagrams and simplified schematic are the same as used on the complete schematics in Section VII; however, some items, such as the HP-IB and microcomputer bias power supplies, are left off the block diagrams and simplified schematic for clarity. Signal names that appear on the drawings are printed in capitals in the descriptions, as are front-panel labels for indicators and controls. Signal names that describe an operating mode or condition are active when that condition exists. For example, OT is high and  $\overline{OT}$  is low if an overtemperature condition exists. In general, signal flow is from left to right and top to bottom, unless arrows indicate otherwise. Signals that lead off the edge of one block diagram pick up in the same relative position on the next block diagram. Some components, such as optical couplers and transformers, are shown in two areas. In these cases, the part of the component or circuit that is shown by dashed lines is shown solidly elsewhere.

### 4-4 HP-IB CIRCUITS

4-5 Figure 4-1 is a block diagram of the HP-IB circuits. These circuits provide the interface between the HP-IB and the rest of the 6034A. Bus-status output signals that are widely distributed on the drawing are identified by mnemonics or signal names in lieu of individual connections to each block. For example, any input labeled LISTEN is high whenever the unit has been addressed as a listener. A pulse symbol ( $\square$ ) indicates that the signal is ordinarily a pulse rather than a level.

4-6 The following description first describes the bus functions and some of the signals that control the unit's operation on the bus. Subsequent paragraphs describe the functions of each of the blocks on the drawing.

### 4-7 Transceivers and Bus Functions

4-8 Information on the HP-IB enters the 6034A through

the transceivers on 16 bidirectional signal lines. The transceivers are three-state devices which either define the direction of data flow or put the lines into a high impedance state so as not to load the bus. The transceivers connect directly to the block labeled Bus Functions, which consists basically of the Hewlett-Packard CHI device (Chip for HP-IB Interface) plus some buffers and inverters. This chip implements nine of the ten HP-IB functions. CHI does not implement the controller function. Between the transceivers and the bus functions there are five bus management lines. These lines are used to manage an orderly flow of information across the interface. They do not control device functions, such as programming a voltage.

4-9 There are also three handshake lines, which function to synchronize the flow of data between this device and other devices on the HP-IB. These are RFD (Ready For Data), DAC (Data ACcepted), and DAV (DAta Valid). For more information concerning these signals and the HP-IB, consult any description of the HP-IB or the IEEE Std 488. In the 6034A, CHI handshakes with the HP-IB.

4-10 CHI also handshakes with the 6034A microcomputer to synchronize events within the 6034A. CHI and the microprocessor use a two-wire handshake for listen mode, and a separate two-wire handshake for talk mode.

4-11 In listen mode, RECEIVE READY is sent to CHI to indicate that the 6034A is ready to receive data.  $\overline{RECEIVE\ HANDSHAKE}$  is sent from CHI to indicate that data on the HP-IB is valid and can be read in.

4-12 In talk mode, TRANSMIT READY is sent to CHI to indicate that the 6034A is ready to send a byte of data. TRANSMIT HANDSHAKE is sent negative true from CHI while data is being read on the HP-IB, indicating that data must be maintained on the DIO lines. TRANSMIT READY can only occur if T.E.1 (Transmit Enable 1) is true, which requires that ATN be true.

4-13 Eight lines comprise the DIO bus. It carries device-dependent messages, such as the voltage being programmed, and commands, such as Talk. In order to differentiate between these two types of data on the DIO bus, the ATN (Attention) line is used. When ATN is true the data is a command, and when ATN is false the data is device dependent. ATN is one of the five bus-management lines.

4-14 The state of the 6034A on the HP-IB is given by the bus status lines. Because the microcomputer does not normally look at the HP-IB, any change of the bus status must be stored and the microcomputer interrupted. After the microcomputer has performed whatever task is required by

the interrupt, the microcomputer then continues to run its program. Any subsequent change in status, such as a reply to the 6034A's response to the initial interrupt, will require another interrupt.

**4-15** There are five circuits which monitor the bus status lines and look for change of state. (The bus status outputs are used in many of the HP-IB circuits, and are shown by mnemonics in lieu of individual connections.) Any time there is a change in the bus status, the change is stored by one of the monitor circuits, each of which connects to the HP-IB Interrupt Monitor and Pulse Generator circuit. In this way the microcomputer becomes aware that something has changed on the HP-IB.

#### **4-16 Serial Poll/Receive Handshake Monitor**

**4-17** SERIAL POLL TRANSMIT ENABLE (SPTE) indicates that the 6034A is being serial polled and is enabled to put its status on the DIO lines. SPTE interrupts the microcomputer, which performs various tasks required to provide the 6034A status to the DIO lines. When the data is ready for the HP-IB, the microcomputer produces a TRANSMIT READY pulse, which causes the Serial Poll/Receive Handshake Monitor circuit to produce DAV ENABLE. DAV is part of the HP-IB handshake sequence, and is ordinarily driven true by CHI only after the microcomputer has generated a TRANSMIT READY signal. However, CHI drives DAV true immediately upon receipt of a serial poll. In order to provide time for the microcomputer to put the serial poll response on the DIO lines, the DAV output from CHI is not connected to the transceivers until the microcomputer generates TRANSMIT READY.

**4-18** This circuit also monitors RECEIVE HANDSHAKE, which is used with RECEIVE READY to coordinate communication between CHI and the microcomputer when the 6034A is in listen mode ( $\overline{\text{Talk}}$ ). CHI drives RECEIVE HANDSHAKE low to indicate that data on the HP-IB is valid and can be read.

#### **4-19 Listen/T.E.1/Talk Monitor**

**4-20** Listen and Talk indicate whether the 6034A is addressed to listen or talk. TRANSMIT ENABLE 1 (T.E.1) indicates that the 6034A is enabled to put data onto the HP-IB. The outputs of this circuit indicate if there has been any change in the status of Listen, Talk, or T.E.1.

#### **4-21 Device Trigger Monitor**

**4-22** A flip-flop in this circuit captures the pulse which CHI produces upon receipt of a DEVICE TRIGGER command from the controller. DEVICE TRIGGER implements the values that have been programmed into the 6034A. Another flip-flop in this circuit remembers the state of DT when data is loaded, because the monitor circuit will be cleared shortly after data is loaded. If a DEVICE TRIGGER pulse were to be received after data is loaded but before the circuit is cleared, that pulse would be lost. The second flip-flop will not let the first flip-flop

be reset unless the data input to the first flip-flop is the same as it was when data was loaded.

#### **4-23 Device Clear Monitor**

**4-24** This circuit captures the pulse which CHI produces upon receipt of a DEVICE CLEAR command from the controller. DEVICE CLEAR disables the power supply output. The DC pulse is protected in the same way as described previously for the DT circuit.

#### **4-25 Transmit Handshake Monitor**

**4-26** This circuit monitors TRANSMIT HANDSHAKE, which is used with TRANSMIT READY to coordinate communication between CHI and the microcomputer when the 6034A is in talk mode. CHI holds TRANSMIT HANDSHAKE low for as long as data is required on the HP-IB. Once CHI determines that data is no longer required on the HP-IB and can be changed, TRANSMIT HANDSHAKE goes high.

#### **4-27 HP-IB Interrupt Monitor and Pulse Generator**

**4-28** This circuit receives inputs from each of the HP-IB status monitor circuits and generates a pulse whenever there is an HP-IB status change. This pulse is processed through the Load/Shift Control circuit to produce the HP-IB INTERRUPT signal that passes through isolation to the microcomputer.

**4-29** This circuit also decodes the  $\overline{\text{T2}}$  and  $\overline{\text{T3}}$  pulses from the microcomputer to produce the  $\overline{\text{CLEAR INTERRUPT}}$  pulse.  $\overline{\text{CLEAR INTERRUPT}}$  does not start until both  $\overline{\text{T2}}$  and  $\overline{\text{T3}}$  occur, and does not end until both  $\overline{\text{T2}}$  and  $\overline{\text{T3}}$  end, thus ensuring a minimum pulse width for  $\overline{\text{CLEAR INTERRUPT}}$  in case  $\overline{\text{T2}}$  and  $\overline{\text{T3}}$  do not occur at the same instant.

#### **4-30 Load/Shift Control**

**4-31** The HP-IB INTERRUPT pulse sets a flip-flop in this circuit to produce the HP-IB INTERRUPT signal to the microcomputer, and it also sets the  $\overline{\text{LOAD/SHIFT}}$  output to  $\overline{\text{LOAD}}$ . The  $\overline{\text{LOAD/SHIFT}}$  signal sets the Data Shifters either to parallel load in eight bits of data or serially shift data in or out upon receipt of clock pulses. The rising edge of the  $\overline{\text{LOAD}}$  output from this circuit resets the DT and DC circuits if either was the cause of the HP-IB interrupt. ( $\overline{\text{LOAD}}$  is prevented from resetting the circuits if they have received a DT or DC pulse after the HP-IB INTERRUPT pulse was generated.)

**4-32** The rising edge of the  $\overline{\text{CLEAR INTERRUPT}}$  pulse resets the HP-IB INTERRUPT signal, preparing it for another HP-IB interrupt. However, a one-shot timer prevents the  $\overline{\text{LOAD/SHIFT}}$  output from being reset back to  $\overline{\text{LOAD}}$  upon receipt of a second HP-IB interrupt until all data from the first interrupt is shifted into the microcomputer.

#### **4-33 Receive Handshake Control**

**4-34** This circuit produces the RECEIVE READY signal to



indicate to the CHI that the microcomputer is ready to receive a byte of data. RECEIVE READY can be generated in one of three ways. In the first case, when the 6034A becomes a listener ( $\overline{\Delta}$ LISTEN and LISTEN) and is not an active talker (T.E.1), the circuit will preset RECEIVE READY without the microcomputer's intervention. Secondly, once the microcomputer begins to read in data bytes, SHIFT enables T3 to toggle RECEIVE READY between true and false. T.E.1 and T.E.1' determine if either of these first two methods control RECEIVE READY, or if the third method controls RECEIVE READY. In this case, the 6034A is addressed to be both a listener and a talker. (This condition is allowed by IEEE STD 488). The microcomputer does not handshake, because the 6034A is not designed to talk to itself. However, to avoid hanging up the

bus, RECEIVE HANDSHAKE sets RECEIVE READY without the microcomputer becoming involved.

### 4-35 Transmit Ready Control

4-36 When the microcomputer is ready to transmit data on the HP-IB it sends a TRANSMIT READY pulse through isolation to set a flip-flop in this circuit. Once CHI begins data transmission it drives TRANSMIT HANDSHAKE low to indicate that data is being provided to the HP-IB and should not be changed. In this circuit, TRANSMIT HANDSHAKE resets the TRANSMIT READY flip-flop. The flip-flop will also be reset if the 6034A changes state from being an active talker.

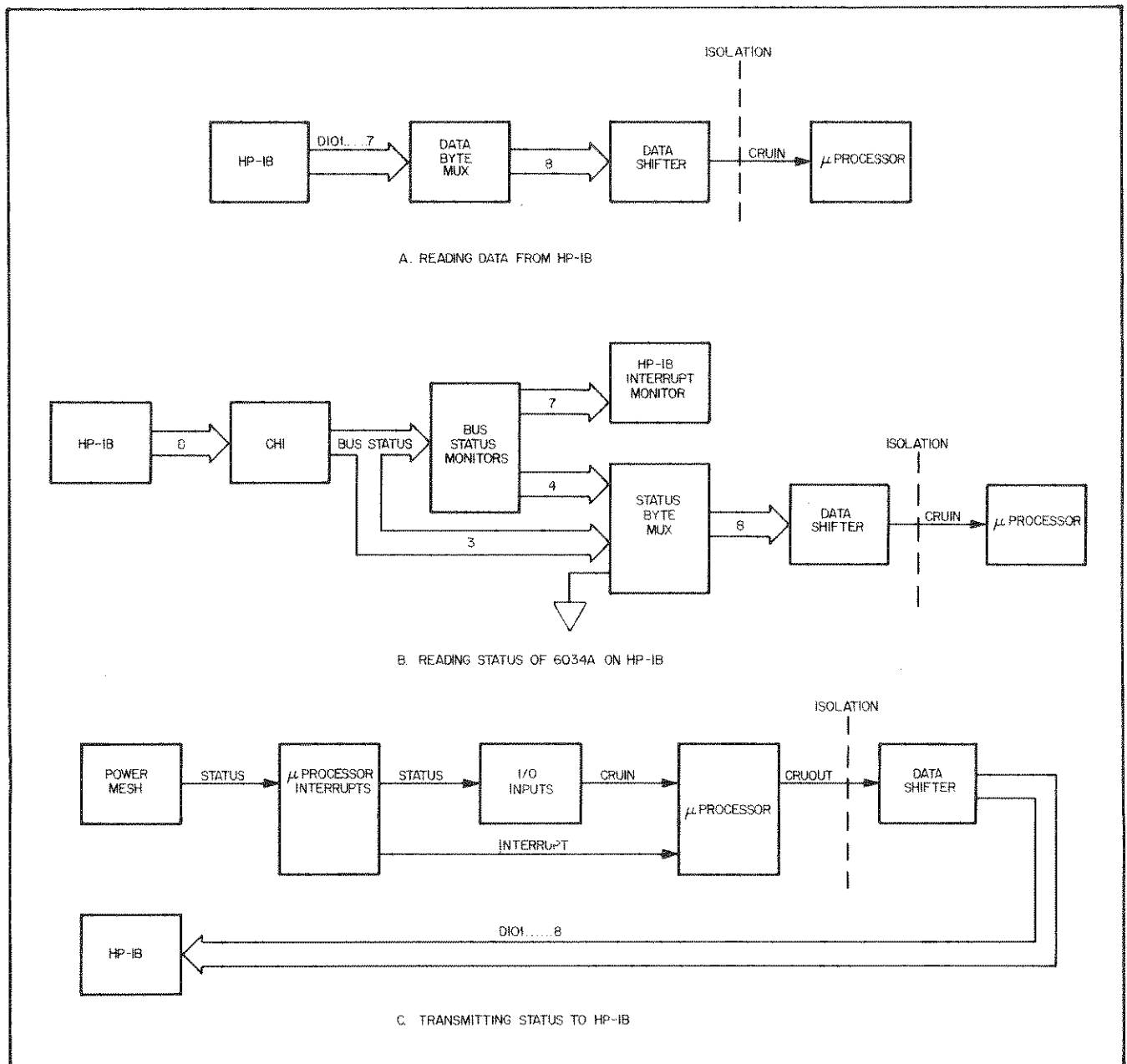

Figure 4-2. Data Flow

## 4-37 Data/Status Multiplexers

4-38 These circuits determine the source of the data supplied to the Data Shifter. When the 6034A is not a talker and RECEIVE HANDSHAKE is true ( $\overline{\text{TALK}} \wedge \text{RECEIVE HANDSHAKE}$ ), the Data byte Multiplexer is enabled. DIO bits 1 through 7 from the HP-IB are then transferred to the Data Shifter. The first bit in the data byte is the complement of the data byte enable. When the enable is active (low) the first bit in the data byte will be high. The first bit identifies the data being supplied to the microprocessor via CRUIN as either a data byte or a status byte, with bit 1 high signifying data byte.

4-39 The complement of the data byte enable also enables the Status Byte Multiplexer. Therefore, when one multiplexer is enabled the other is disabled. The status byte contains seven bits that provide information about changes on the HP-IB and the present state of the HP-IB. The first bit of the status byte is tied low, signifying to the microprocessor a status byte.

## 4-40 Data Shifter/Output Buffer

4-41 This circuit has an eight-bit parallel input and an eight-bit parallel output. It also has a serial input and serial output. LOAD/SHIFT determines whether data is parallel loaded in or serially shifted in and out. The loading or shifting occurs upon receipt of pulses from isolator T2. Figure 4-2 shows data flow through the Data Shifter in three cases.

4-42 In Figure 4-2A, DIO bits 1 through 7 are loaded from the Data Byte Multiplexer into the data shifter by a T2 pulse when LOAD/SHIFT is in LOAD state. After LOAD/SHIFT changes to SHIFT state, T2 pulses shift data out of the data shifter to CRUIN. In Figure 4-2B, data indicating the HP-IB status is parallel loaded into the data shifter. Note that one of the bits, the first one to be loaded into CRUIN, is hardwired low. This identifies the data as a status byte. Figure 4-2C shows data being serially loaded into the data shifter from the microprocessor. The data outputs are enabled when the 6034A is enabled to talk or is serial polled.

4-43 Output bits 7 and 8 from the data shifter are connected to the DIO bus through 3-state buffers. When the 6034A is addressed as a talker, DIO 7 is driven by the data shifter/output buffer. However, when the 6034A is serial polled the DIO 7 data shifter output is disabled and DIO 7 is driven directly by CHI to indicate whether the 6034A was requesting service when it was polled. (DIO 7 is the only DIO line that can be driven by CHI.) DIO 8 is driven by the data shifter only during serial poll. When the 6034A is addressed as a talker and is sending data, the DIO 8 output is held high. However, the bit 8 output from the data shifter drives EOI on the HP-IB;  $\overline{\text{EOI}}$  indicates last byte.

## 4-44 Isolation Components

4-45 The HP-IB circuits are isolated from the rest of the 6034A. This allows a system to be configured without a com-

mon ground reference. Isolation also reduces the possibility of forming ground loops in complex systems. Potential differences between different grounds can lead to noise problems that are difficult to locate and solve. In the 6034A both optical couplers and transformers are used for isolation to maximize speed and reliability.

## 4-46 MICROCOMPUTER

4-47 Figure 4-3 is a block diagram of the microcomputer section of the 6034A, including the three DACs that program output voltage, output current, and overvoltage protection. The heart of the microcomputer is the Microprocessor. Because many of the signals to and from the Microprocessor are widely distributed, mnemonics are used in lieu of individual connections to each block. The A9 through A13 and CRUCLK outputs from the microprocessor are buffered for use in some circuits. The buffered signals are identified by a prime symbol (e.g., A9'). Note that the A13 output is also used for CRUOUT, and is identified as A13 (or A13') wherever it is used for addressing, and CRUOUT (or CRUOUT') wherever it supplies the CRUOUT signal from the microprocessor.

## 4-48 Memory Circuits

4-49 The ROM circuit consists of either one 64K masked ROM or four 16K EPROMs. Factory-set jumpers in the Memory Address Decoding circuits ensure the microprocessor accesses the proper address in ROM. The block diagram is based on 64K ROM, so ROM2, ROM3, and ROM4 are not used. Appendix C shows connections used for 16K EPROMs.

4-50 The RAM circuit consists of either two 256-bit RAMs or two 1K RAMs. Factory-set jumpers decode the RAM $\overline{\text{T}}$ , WRITE ENABLE, and address inputs for the device in use.

## 4-51 Microprocessor Interrupts

4-52 While the power supply is operating normally, with no faults and no commands to implement, the microprocessor program operates in an idle loop. When the microprocessor is required to perform a task an interrupt must be generated. As will be explained, this will occur at least every millisecond. The 6034A organizes interrupts into five priority levels, with a high priority interrupt able to interrupt any lower level.

4-53 The highest priority interrupt is  $\overline{\text{PON}}$  (Power ON). Although not shown on the block diagram, the bias power supplies for the HP-IB circuits and the microcomputer circuits each produce a PON signal ( $\overline{\text{PON}}_1$  and  $\overline{\text{PON}}_2$ ) whenever the unregulated dc input to the bias supplies is insufficient to ensure proper output from the bias supplies to operate the digital circuits. Normally this occurs only during power up or down, or during brownout conditions. The PON circuits are designed to ensure that during power up and down the PON signal will exist while the digital circuits are able to operate, so that the microcomputer will be interrupted, note the PON signal, and be able to respond to a serial poll that PON has occurred.

4-54 The second highest priority interrupt is not shown on the block diagram, and is used only for manufacturing test at the factory.

4-55 The POWER MESH STATUS lines ( $\overline{M1}$ ,  $\overline{CC}$ ,  $\overline{M2}$ ,  $\overline{CV}$ ,  $\overline{OT}$ ,  $\overline{OV}$ ) drive the third level interrupt. Once the microprocessor has noted a power mesh interrupt, the microprocessor monitors the power mesh continuously via CRUIN. The microprocessor then disables the POWER MESH INTERRUPT ENABLE so that low priority interrupts can operate. Note that the POWER MESH STATUS signals only interrupt the microprocessor via this circuit, they do not tell the microprocessor the power mesh status. The POWER MESH STATUS signals are sent to the I/O inputs circuit on the front panel, where they are loaded into the microprocessor via CRUIN once the microprocessor responds to the interrupt.

4-56 HP-IB INTERRUPT is the fourth level microprocessor interrupt. As explained in the HP-IB Circuit section, the microprocessor has to load a status byte in via CRUIN to determine the exact cause of an HP-IB INTERRUPT.

4-57 The lowest priority microprocessor interrupt is the 1 MILLISECOND TIMER signal, which comes from the microcomputer bias power supply circuit. This signal is used by the microprocessor to time the service-request delay after new output values have been programmed. The interrupt also causes the microprocessor to load CRUIN so it can check the Rotary Pulse Generator Decoders to determine if the front-panel OUTPUT ADJUST control has been turned and check if the OUTPUT ADJUST pushbutton is pressed.

4-58 Microprocessor interrupts are encoded onto three lines, IC0, IC1, and IC2, which connect to the microprocessor. This three-line code represents the highest level interrupt recognized by the microprocessor interrupts circuit.

#### 4-59 CRU Clock Generator

4-60 Clock pulses are required to shift data from the Data Shifters across isolation to the microprocessor CRUIN. The CRU Clock Generator monitors which address the microprocessor is looking at. When the circuit notes that the microprocessor has advanced to the next address, a clock pulse is generated. Other inputs to this circuit determine whether the pulse is connected to T2, T3, or both.

#### 4-61 I/O Address Decoding

4-62 This circuit decodes which address the microprocessor is addressing and enables various gates in the microcomputer circuits and on the front-panel assembly to determine where data will be sent to or received from. For example, the outputs from this circuit determine whether CRU Clock pulses are connected to T2 or T3. Other outputs determine which DAC is loaded, and which I/O latches are enabled.

#### 4-63 DAC Circuits

4-64 The three DAC circuits, one each to control output voltage, output current, and OVP trip voltage, are similar. Address lines address each latch in turn, eight for OVP and twelve each for voltage and current, and data from CRUOUT is loaded. The analog outputs from the DACs are connected to front-panel reference circuits, whose outputs are compared to the actual power supply output.

#### 4-65 FRONT-PANEL ASSEMBLY

4-66 Figure 4-4 is a block diagram of the front-panel assembly, which contains the microprocessor I/O circuits, output current, voltage and OVP reference circuits, the rotary-pulse generator, and the front-panel display circuits.

#### 4-67 I/O Inputs

4-68 This circuit multiplexes data concerning the status of the power mesh, the OUTPUT ADJUST controls, and the CV and CC readback comparators onto the microprocessor CRUIN line. Note that CRUIN will be loaded at least once every millisecond because of the interrupt generated by the 1ms timer, so even very rapid operation of the OUTPUT ADJUST controls will be observed.

#### 4-69 I/O Outputs

4-70 The microprocessor CRUOUT is connected to addressable latches in this circuit. Sixteen of these latches drive the LEDs on the front panel. Other outputs tell the Microprocessor Interrupts circuit which operating mode is selected so that circuit can compare the actual operating mode (CV or CC) to the selected mode (M1 or M2). The microprocessor also uses CRUOUT to reset the Rotary Pulse Generator Decoders and OVP, enable or disable power mesh interrupts, and request service.

#### 4-71 Constant Current Reference Circuit

4-72 The CC reference circuit receives the CC DAC output signal and produces from it the 0-volt to 5-volt CC programming voltage that is supplied to the CC control circuit on the control board.

4-73 Figure 4-5 is a simplified schematic of the CV and CC reference circuits, showing the relationship of components on the HP-IB/microcomputer assembly and the front-panel assembly. Reference designators in parenthesis are for CC circuit components, others are for CV circuit components.

4-74 As can be seen, the analog output from the DAC is applied to a reference amplifier circuit. The feedback resistors for the reference amplifier are in the DAC package, so that any temperature-induced drift is self correcting. The reference

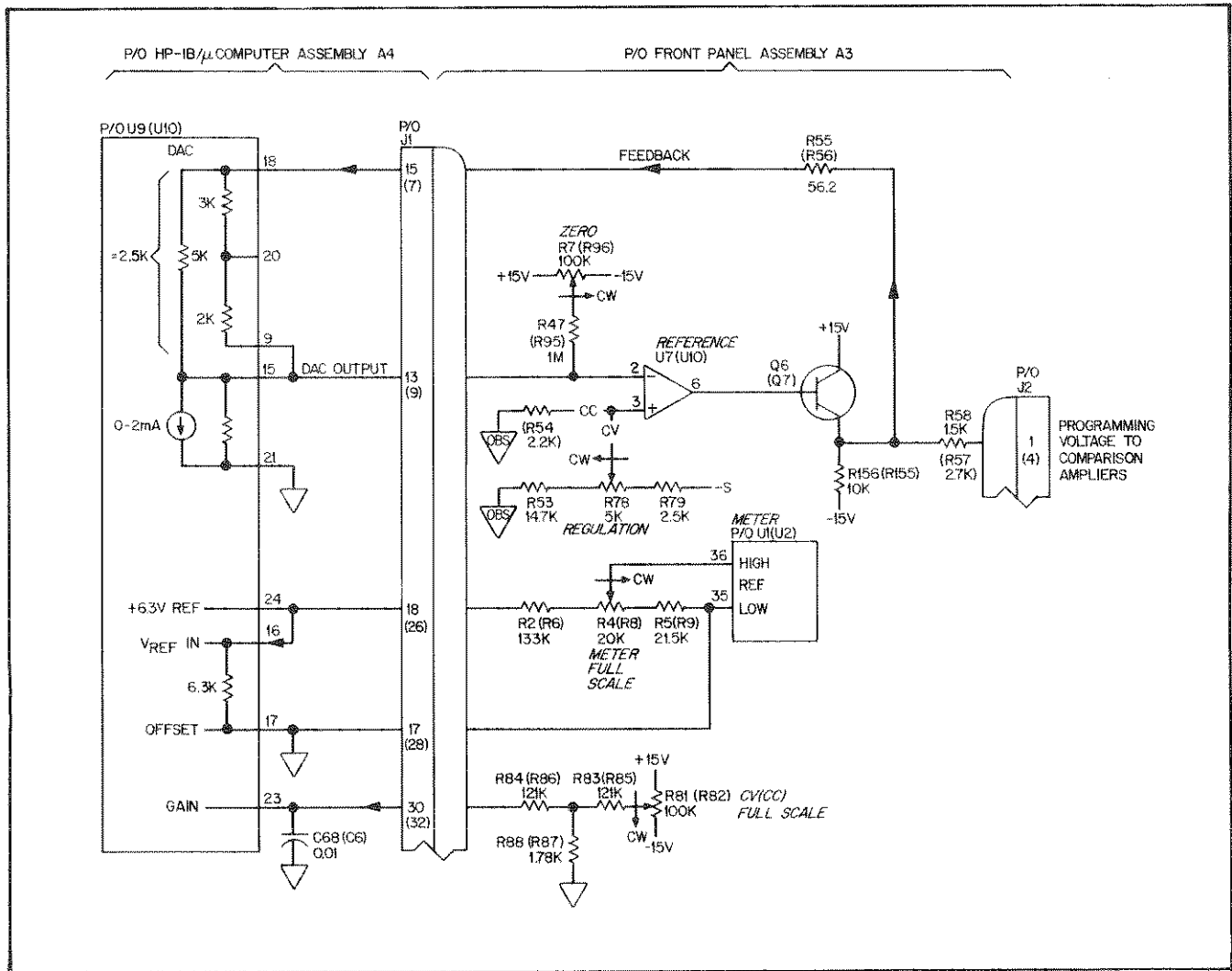

Figure 4-5. Simplified Schematic, CV (CC) Reference Circuit

amplifier output is a 0-volt to 5-volt level that is compared to a voltage representing actual power supply output current (or voltage).

4-75 The programming voltage is also applied to a comparator in the constant current reference circuit (not shown on the simplified schematic) and compared to the I-MONITOR AMPLIFIER OUTPUT, a voltage that is proportional to actual power supply output current. This comparator is used for reading back the output current when the power supply is operating in CV mode, as follows.

4-76 When the microprocessor is asked to transmit to the controller the actual output current (the controller knows the programmed limit), the microprocessor starts to program progressively lower output current values, one bit at a time. Eventually the CC PROGRAMMING VOLTAGE becomes equal to or slightly lower than the I-MONITOR AMPLIFIER OUTPUT voltage, and the readback comparator changes state. The comparator's output goes low to indicate that the CC DAC output is proportional to the power supply output current. The

microprocessor then knows that the most recently programmed output current equals the actual output current from the power supply. The microprocessor encodes that value for transmission to the controller, and the microprocessor restores the current limit previously programmed.

#### 4-77 Constant Voltage Reference Circuit

4-78 This circuit is similar to the constant current reference circuit. The CV DAC OUTPUT produces the CV PROGRAMMING VOLTAGE, and the CV DAC OUTPUT is compared to the  $\pm$  Sense lines to read back the actual power supply output voltage when the unit is operating in CC mode.

#### 4-79 Voltmeter Range Circuit

4-80 The voltmeter is designed to blank the display if it goes overrange. This circuit monitors two segments of the most significant whole digit to note if the display goes blank, and switches in greater attenuation to the voltmeter input. This circuit also enables the proper decimal point for high or

low range. The OVP DISPLAY pushbutton on the front panel causes the range circuit to switch to high range, turn on the OVP SET indicator, and connect the OVP TRIP VOLTAGE to the voltmeter input.

#### 4-81 Rotary Pulse Generator Decoders

4-82 When rotated, the rotary pulse generator (RPG) produces two pulse trains that are 90° phase shifted from each other. This circuit contains two flip-flops that monitor the RPG outputs. The output of one flip-flop goes high to indicate that the RPG has been rotated, and the output of the other goes high to indicate CW rotation or low to indicate CCW rotation. After the microprocessor notes, via CRUIN, that the RPG has been rotated, the microprocessor resets the RPG Decoders.

4-83 Because the microprocessor checks CRUIN at least every millisecond, it can determine if the RPG is being turned rapidly (for a large change) or slowly (for fine adjustment), and the microprocessor varies the rate it changes the DAC inputs accordingly.

#### 4-84 Voltmeter and Current Meter

4-85 The voltmeter measures the attenuated sense voltage or the OVP trip voltage from the voltmeter range circuit and displays the value on a 3 1/2 digit readout. The voltmeter range circuit lights the appropriate decimal point for either range. The current meter measures the output of the current-monitor amplifier on the control board. The current meter has a fixed decimal point.

#### 4-86 POWER MESH AND CONTROL BOARD

4-87 The basic operating concepts of the power mesh are shown on the simplified schematic, Figure 4-7, and described in the following paragraphs. The beginning paragraphs describe the basic difference between an autoranging power supply and a conventional CV/CC power supply in terms of the available output, and provide an overview of the basic theory of operation. Later paragraphs describe the functions of each of the blocks on the simplified schematic. The heavy lines represent the input rails and output rails.

4-88 The basic difference between an autoranging power supply and conventional types of Constant Voltage/Constant Current (CV/CC) power supplies can be seen by comparing the output characteristics of each. A conventional CV/CC power supply can provide maximum output power at only one combination of output voltage and current, as shown in Figure 4-6A. The range of a power supply can be extended by designing an instrument with two or more switch-selectable voltage/current ranges within the maximum power output capability, as shown in Figure 4-6B. An autoranging power supply provides maximum output power over a wide and continuous range of voltage and current combinations, as shown in Figure 4-6C, without the operator having to select the proper output range.

4-89 The 6034A is a flyback-type switching power supply, so-called from the flyback technique of generating high voltage in television receivers. In the 6034A, energy is stored in the magnetic field surrounding a transformer while current flows in the primary, and is transferred to the secondary circuit when current flow in the primary is turned off. Current flow in the primary is controlled by a pair of FET switches which are turned on and off at a 20 kHz rate by a pulse width modulator. Regulation is accomplished by controlling the on time of the FET switches. On pulses are generated by a clock circuit. Off pulses are generated when current flow in the primary has stored enough energy for the output circuit, which is determined as follows.

4-90 The output voltage and current are compared to reference voltages set by the DACs and reference circuit to produce a control voltage. The control voltage indicates the amount of power required by the output circuit. Current flow in the primary circuit produces a ramp voltage that represents the amount of energy being stored for transfer to the output circuit. An off pulse is generated when the ramp voltage exceeds the control voltage.

#### 4-91 Input AC Circuits

4-92 Primary power is connected to the input rectifier and input filter. Jumper W1 is used only for 100 V or 120 V operation to connect the input filter as a voltage doubler, so that for any nominal input voltage the input filter charges to approximately 300 volts dc. Thermal resistors RT1 and RT2 have high

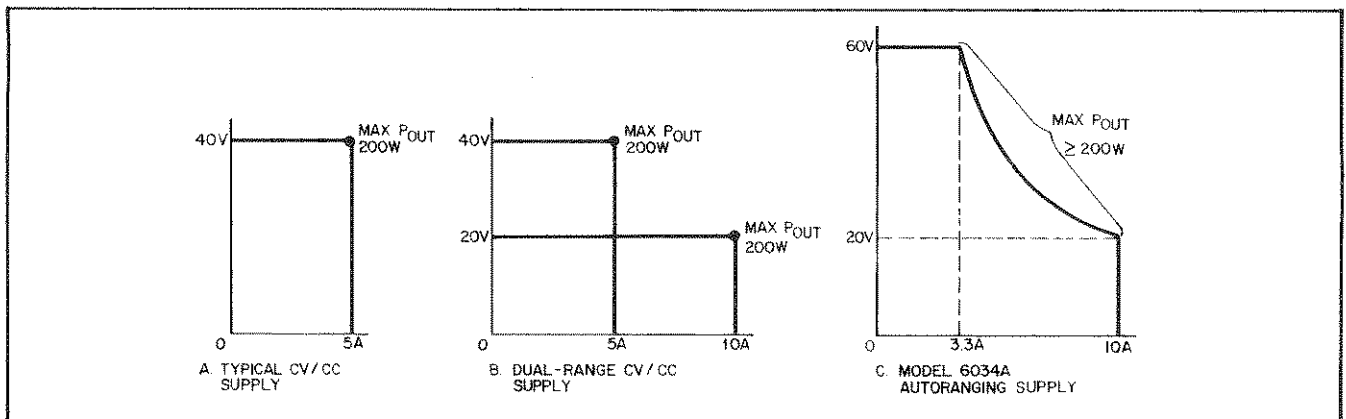

Figure 4-6. Output Characteristics; Typical, Dual-Range, and Auto-Ranging Supplies

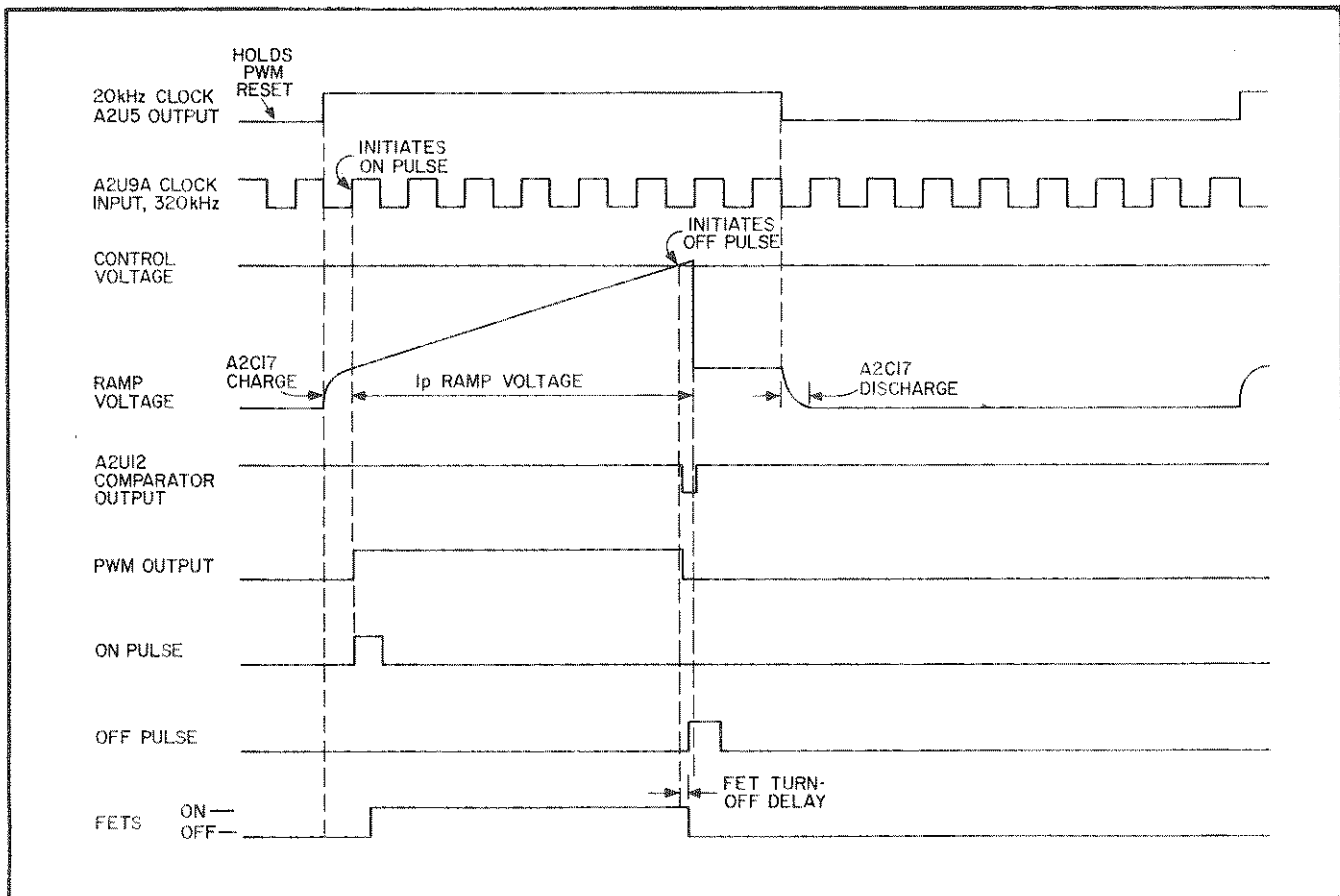

Figure 4-8. FET Control Signals Timing Diagram

resistance when cold to limit inrush current when the instrument is first turned on and capacitors in the input filter charge up. When the instrument is turned off, the input filter capacitors discharge slowly and the thermistors cool off. Therefore, if the instrument is turned on again within 30 to 60 seconds of being turned off, inrush current is limited by the combined effects of the remaining charge and thermistor resistance.

#### 4-93 DC to DC Converter

4-94 Current flow from the input rails through power transformer T1 is controlled by FET switches Q1 and Q2. On and off signals for the FETs are derived from the Pulse Width Modulator, as will be described shortly. The on pulses are applied through diodes CR12 and CR11 to the gates of Q1 and Q2. Although the on pulse is only about  $1.5\mu$  sec duration, the FETs' input capacitance hold the FETs on after the on pulse has disappeared.

4-95 When the FETs are turned on, current flows through the primaries of power transformer T1 and primary-current monitor transformer T2. The output rectifier CR13 is reverse biased and blocks current flow in the T1 secondary. Consequently, energy is stored in the field that builds around the T1 transformer windings. The longer that voltage is applied to the

primary, the more energy is stored. Current flow in the secondary of T2 develops the  $I_p$  RAMP VOLTAGE across resistor A2R118. The amplitude of this linearly increasing voltage corresponds to the amount of current flow through the T1 primary; therefore, it represents the amount of energy being stored in the field around T1. It is this  $I_p$  RAMP VOLTAGE that is compared to a control voltage to determine when the FETs should be turned off.

4-96 When the FETs are turned off, the collapsing magnetic field reverses the polarity across the T1 primary and secondary, and current flows from T1 secondary through output rectifier CR13 to charge output capacitors C16, C17, and C18. The level to which the output capacitors are charged corresponds to the length of time that the FETs are on and current flows in T1 primary.

4-97 When the FETs turn off, the leakage inductance of T1 develops a small amount of reverse current flow in the primary circuit. Flyback diodes CR5 and CR6 protect the FETs by conducting this current around the FETs and back to the input filter.

4-98 It can be seen that the power available in the output circuit corresponds to the duty cycle of the FET switches. The following paragraphs describe the method by which output voltage and current are sensed to control the FET duty cycle.

#### 4-99 Constant Voltage (CV) Control Circuit

4-100 The Constant Voltage (CV) Control Circuit compares a percentage of the output voltage to the CV PROGRAMMING VOLTAGE set by the reference circuit on the front panel. Any difference is amplified to establish a control voltage.

4-101 Amplifier A2U13 compares a fraction of the 6034A output voltage at the + Sense terminal to the programming voltage. The output of A2U13 is applied to a second comparison amplifier, A2U14A. This amplifier compares the output of A2U13 to a fraction of the inboard + Out, which is the + output voltage sensed at the inboard side of the output filter. Use of two comparison amplifier loops provides increased stability for load variations.

4-102 In normal CV mode, the output of A2U14A varies between  $\approx -0.5$  volts and  $\approx +1.0$  volts. It is at its most negative when the load is drawing little or no power from the instrument. Progressively more-positive voltages from A2U14A correspond to increased power demand by the load. The output from the CV Circuit is applied to diode A2CR18.

#### 4-103 Constant Current (CC) Control Circuit

4-104 Operation of the Constant Current (CC) Control Circuit is similar to the CV Circuit. Output current from the 6034A develops a voltage across the current-monitor resistance ( $R_M$ ) consisting of R28 and R29. This voltage is amplified and buffered by the I-Monitor Amplifier to isolate the output from currents in the CC Circuit. In normal CC mode, the output from the CC Circuit also varies between  $\approx -0.5$  volts and  $\approx +1.0$  volts, and is applied to diode A2CR19.

#### 4-105 Control Voltage

4-106 The outputs of the CV And CC Circuits are applied to diodes that connect to a wired-OR junction. Whichever circuit is requesting less power will forward bias its output diode and determine the voltage at the wired-OR junction. As stated earlier, the outputs vary between  $-0.5$  volts and  $+1.0$  volts, with the more negative levels representing lower power demands. The wired-OR junction at the anodes of A2CR18 and A2CR19 is biased to  $+1.5$  volts. Therefore, whichever circuit, CV or CC, produces the more negative output will cause its output diode to be forward biased and thereby determine the CONTROL VOLTAGE. This CONTROL VOLTAGE is compared to the Ip RAMP VOLTAGE to determine when the FET switches are turned off.

4-107 For example, assume the output from the CV Circuit (A2U14A) is  $+0.2$  volts and the output from the CC Circuit (A2U14C) is  $+0.8$  volts. A2CR18 will be forward biased and the wired-OR junction will be held at  $+0.8$  volts (includes the  $0.6$  volt drop across A2CR18). A2CR19 will be reverse biased, so the CC Circuit will have no effect.

#### 4-108 Pulse Width Modulator

4-109 The FET Switches are turned on and off at a  $20$  kHz rate by signals derived from the Pulse Width Modulator (PWM). On pulses are initiated by the  $20$  kHz clock signal. Off pulses are initiated when the Ip RAMP VOLTAGE (which indicates the amount of energy being stored for transfer to the output circuit) exceeds the CONTROL VOLTAGE (which indicates the amount of power required by the output circuit). Figure 4-8 is a timing diagram showing the relationship of various signals that control the FET switches.

4-110 The more negative level of the  $20$  kHz A2U5 output resets both flip-flops A2U9A and A2U9B and holds them reset until the A2U5 output goes positive. Then, the next positive edge from the output of the  $320$  kHz oscillator triggers A2U9A, triggering A2U9B and one-shot multivibrator A2U10A. The FET switches are turned on, current flows through transformer T2, and Ip RAMP VOLTAGE starts to rise. When Ip RAMP VOLTAGE exceeds the CONTROL VOLTAGE, the output of A2U12 changes state and flip-flop A2U9B is reset, triggering one-shot multivibrator A2U10B to produce an off pulse.

#### 4-111 PWM Fast Turn Off

4-112 Figure 4-8 shows that there is a delay between the time when the CONTROL VOLTAGE is exceeded at A2U12 and the time when the FETs turn off. This delay consists of the comparator switching time, gate delays, transformer delay, and FET turn-off time, and it results in a certain amount of power begin transferred to the output after the desired off time. If the CONTROL VOLTAGE is a very low level (unit supplying little or no output power), this power may exceed the amount required by the load. To offset this, the PWM is designed to reduce the minimum on-time of the FETs if necessary to reduce the power transferred to the output circuit. When the  $20$  kHz clock goes high (allowing the PWM to be triggered by the next  $320$  kHz signal), A2C17 charges rapidly and exponentially to a low level. If this level exceeds the CONTROL VOLTAGE, the PWM initiates an off pulse, turning off the FETs immediately after they have turned on. Although the charge on A2C17 can exceed the CONTROL VOLTAGE and change the output state of comparator A2U12 even before the FET switches have turned on, circuit delays of the off pulse are such that the FET switches will be turned on each cycle (assuming the PWM is not inhibited by other circuits).

#### 4-113 Primary Current (Ip) Limit

4-114 Ip RAMP VOLTAGE is also compared to a preset Ip LIMIT at comparison amplifier A2U4B. Ip LIMIT is a factory-set adjustment that limits the total power output of the instrument. Ordinarily, the PWM generates an off pulse when Ip RAMP exceeds the CONTROL VOLTAGE at A2U12, and Ip RAMP never reaches Ip LIMIT at A2U4B. However, if the CONTROL VOLTAGE is excessively high (both CV and CC programming voltages set to relatively high values), Ip RAMP will ex-

ceed Ip LIMIT. The output of A2U4B changes state, initiating an off pulse.

4-115 As an additional protection feature, if nothing else resets flip-flop A2U9B (such as the control circuit, over temperature, dropout, or overvoltage), it will be reset by the next negative level from A2U5, triggering A2U10B to generate an off pulse. Therefore, maximum duty cycle is always less than 50%.

#### 4-116 Bleed Circuit

4-117 This circuit enables the 6034A to regulate properly even at very low output current and/or voltage levels. The circuit conducts approximately 25 milliamperes from the + output line to the -8 V supply, thereby ensuring that the FET switches will be turned on each cycle even if the load is drawing little or no power. As the output voltage is increased, R31 becomes the predominate path for bleed current.

#### 4-118 Down Programmer

4-119 This circuit allows the output voltage to be lowered rapidly when required. In order to lower the output voltage it is necessary to discharge the output filter capacitors (typically, through the load). In situations that require the output voltage to drop more rapidly than can be accomplished through the load, the Down Programmer pulls the output line to a low level and discharges the capacitors. This action can be triggered by one of four conditions: The CV Circuit programs a lower output voltage, an overvoltage is detected on the output, primary power dropout is detected, or the power supply is disabled.

4-120 A long-carryover bias supply associated with the Down Programmer stores enough energy to operate the Down Programmer after loss of primary power. This ensures that the Down Programmer will be able to discharge the output circuit completely when primary power is turned off.

4-121 The Down Programmer is disabled by U1A approximately seven seconds after being triggered. This prevents the circuit from trying to sink current continuously from a parallel-connected power supply.

#### 4-122 Overvoltage Protection Circuit

4-123 The Overvoltage Protection Circuit monitors the output voltage across the +Out Line and circuit common (- Out Line). If the output voltage exceeds a preset limit, set by the OVP Reference circuit on the front panel, the Overvoltage Protection Circuit inhibits the PWM, triggers the Down Pro-

grammer and latches itself until the instrument is reset or turned off.

4-124 The Overvoltage Protection Circuit operates from the long-carryover bias supply associated with the Down Programmer. By ensuring that the bias voltage remains high until after the + Out reaches zero volts when the instrument is turned off, this feature prevents the Overvoltage Protection Circuit from latching if the unit is turned back on again immediately after turn-off.

#### 4-125 AC Dropout Detector

4-126 The AC Dropout Detector operates to shut down the power mesh when primary power is turned off or lost. It inhibits the PWM so that the FETs cannot be turned on inadvertently while the control circuits may be dropping out, and it ensures that the output circuit is completely discharged. Power dropout is detected by a ramp circuit that is reset by the rectified ac pulses in the unregulated +5 V. If the ramp is not reset within approximately 20 milliseconds of the previous reset, the AC Dropout Detector inhibits the PWM and triggers the Down-Programmer.

#### 4-127 Bias Voltage Detector

4-128 The Bias Voltage Detector inhibits both the PWM and On Driver when the instrument is turned on until the internal +5 V supply stabilizes, thus ensuring that the FET switches cannot turn on before the control circuits are able to operate. When the instrument is turned on, the outputs of the bias power supplies begin to rise from 0 volts. When the output of the +5 V Regulated supply reaches approximately 1 volt, transistors in the Bias Voltage Detector turn on and inhibit the PWM and the On Driver. The inhibit signals remain on until the output of the +5 V Unregulated supply exceeds approximately +9 volts, at which point the +5 V Regulated supply is certain to be stabilized.

4-129 The Bias Voltage Detector also inhibits the PWM and On Driver in "brownout" conditions if the ac line voltage falls below approximately 70% of nominal.

#### 4-130 Over Temperature Detector

4-131 Thermostat TS1 is mounted on the FET heatsink in the fan airflow. If the FET case temperature rises excessively (from high external air temperature and/or internally generated heat) TS1 opens and inhibits the PWM until the temperature drops. The cooling fan continues to operate.



## Section V MAINTENANCE

### 5-1 INTRODUCTION

5-2 Upon receipt of the power supply, the performance test (paragraph 5-5) can be made. This test is suitable for incoming inspection. If a fault is detected in the power supply while making the performance test or during normal operation, proceed to the troubleshooting procedures. After troubleshooting and repair (paragraph 5-53) perform any necessary adjustments and calibration (paragraph 5-121). Before returning the power supply to normal operation, repeat the applicable portions of the performance test to ensure that the fault has been properly corrected and that no other faults exist.

### 5-3 TEST EQUIPMENT REQUIRED

5-4 Table 5-1 lists the test equipment required to perform the various procedures described in this section.

### 5-5 PERFORMANCE TEST

5-6 The following test can be used as an incoming inspection check and appropriate portions of the test can be repeated to check the operation of the instrument after repairs. The tests are performed using the specified nominal input voltage for the unit. If the correct result is not obtained for a particular check, proceed to troubleshooting (paragraph 5-53).

### 5-7 Measurement Techniques

5-8 All specifications are measured at the rear terminals of the power supply. Also, all tests are performed with the supply strapped for local programming and sensing, as shown in Figure 3-3. The wires used to connect the load to the supply should be heavy enough to ensure that they will drop less than 0.5 V. The procedures are written for use of local (front-panel) controls. However, output voltage and current can be set via HP-1B.

5-9 **Selecting a Load Resistor.** Specifications are checked with varying amounts of load resistance connected across the supply. For most of the constant-voltage tests, the value of load resistance must be  $2\Omega$  to permit operation of the supply at 20 V and its maximum-output-power-rating current of 10 A. For the constant-current tests, the load resistance must be approximately  $18\Omega$  to permit operation at 3.3 A and its maximum-output-power-rating voltage of 60 V. The power rating of the load resistance must be at least equal to the maximum output power of the supply: 230 watts.

5-10 Either fixed or variable (rheostat type) load resistors can be used. However, a rheostat is very convenient when changing values and for accurately setting the output current of the supply. Table 5-1 lists a rheostat that is adequate for this supply. For clarity, illustrations in this section show the rheostat as a single resistor, although the recommended unit is a twin resistor model to provide adequate current capacity. If fixed resistors are used, their tolerance must be accounted for when evaluating the test results.

5-11 **Connecting a Current-Monitoring Resistor.** To allow precise measurement of output current, a current-monitoring resistor is inserted between the output of the power supply and the load resistance. This resistor must be connected as a four-terminal device in the same manner as a meter shunt would be (see Figure 5-1). The load current is fed to the extremes of the wire leading to the resistor, while the monitoring terminals are located as close as possible to the resistance element itself. A current-monitoring resistor should have low noise, a low temperature coefficient (less than 30 ppm/°C), and should be used at no more than 5% of its rated power so that its temperature rise will be minimized.

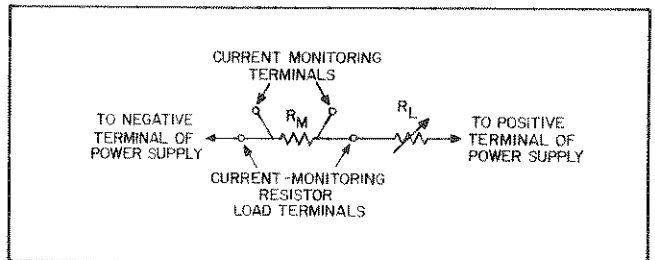

Figure 5-1. Current-Monitoring Resistor Terminals

### 5-12 Constant Voltage Tests

5-13 Connect all of the measuring devices used in the constant-voltage performance tests directly to the power supply sensing terminals (+ S, - S). For best accuracy, the sensing terminals must be used rather than the output terminals, since the measuring instruments must be connected to the same pair of terminals to which the feedback amplifier within the power supply is connected. This is particularly important when measuring the regulation or ripple of the power supply. A measurement made across the load includes the impedance of the leads to the load, and such lead lengths can easily have an impedance several orders of magnitude greater than the supply impedance (typically  $< 1$  milliohm at dc), thus invalidating the measurement.

Table 5-1. Test Equipment Required

Type	Required Characteristics	Use	Recommended Model
Oscilloscope	Sensitivity: 1 mV Bandwidth: 20 MHz	Troubleshooting, measure ripple and noise spikes.	HP 1740A
Isolation Transformer	1 KVA	Troubleshooting	
RMS Voltmeter	True RMS, 10 MHz bandwidth, 1 mV sensitivity	Measure ripples	HP 3400A
Variable Voltage Autotransformer	Capable of handling 0 line voltage + 15% at 5.5 amps	Vary ac input for line regulation measurement and troubleshooting.	
Multimeter	Resolution: 12 $\mu$ V Accuracy: 0.02%, 5 $\frac{1}{2}$ digit	Measure ac and dc voltages, resistance, and for troubleshooting and calibration.	HP 3455A
Resistive Load	250 Watts	Power supply load resistor (rheostat or fixed resistors.)	James G. Biddle non-inductive rheostat 411KN546T
Current-Monitoring Resistor	Value: 100 Mv @ 10 A (10 m $\Omega$ ) Accuracy: 0.003% *	Measure output current, calibration	*Leeds and Northrup Model 4222-B, 0.01 $\Omega$ 0.003% Accuracy, 10 Watts
Terminating Resistors	Value: 50 $\Omega$ $\pm$ 5%, non-inductive (four required)	Noise spike measurement	
Blocking Capacitors	Value: 0.01 $\mu$ F, 100 Vdc (two required)	Noise spike measurement	
Switch	SPST, 10A capacity @ 60 V	Load effect tests	
Signature Analyzer		Troubleshooting the HP-IB and microprocessor circuits.	HP 5004A
Controller	Full HP-IB capabilities	Troubleshooting calibrating and verifying operation.	HP 85 or HP 9825
Logic Pulser		Troubleshooting	HP 546A
DC Power Supply	0-40 volts, 0-2 amps	Troubleshooting	HP 6256B
Resistor	1K $\Omega$ , 190, 1/8 W metal film	Calibration	0757-0280
Precision DC Supply	0-60 V, 0-50 mA Resolution: 1m V High Stability	Calibration	HP 6116A

\*The recommended current-monitor resistor is designed to be operated in an oil bath to maintain temperature stability. However, satisfactory results will be obtained by monitoring the resistor temperature and ensuring that it does not change more than 5°C during the procedure. Less accurate, and less expensive current-monitor resistors can be used, but current-programming accuracy specifications must be reduced accordingly.

5-14 To avoid mutual coupling effects, connect each monitoring device to the sensing terminals by a separate pair of leads. Use twisted pairs or shielded two-wire cables to avoid pickup on the measuring leads. Connect the load resistor across the output terminals as close to the supply as possible. When measuring the constant-voltage performance specifications the current control should be set at least 2% above the output current the load will draw, since the onset of constant-current operation could cause a drop in output voltage, increased ripple and other performance changes not properly ascribed to the constant-voltage operation of the supply.

**5-15 Rated Voltage and Voltmeter Accuracy.** To check that the supply will furnish its rated output voltage, proceed as follows:

- Connect test setup shown in Figure 5-2. Set  $R_L$  to maximum resistance initially.
- Turn on supply and turn up output voltage. If unit switches to CC LIMIT mode, use OUTPUT ADJUST controls to increase CC limit so that unit remains in CV mode.
- Adjust output voltage until digital voltmeter (DVM) indicates exactly 60 V (maximum rated output voltage).
- Front-panel voltmeter should indicate 60.0.
- Disconnect DVM from power supply sense terminals and connect DVM across current-monitoring resistor ( $R_M$ ).
- Reduce resistance of  $R_L$  until DVM reads 33 mV, indicating that current output is exactly 3.3 A (maximum rated power output). Ensure that power supply remains in CV mode.
- Disconnect DVM from  $R_M$  and reconnect DVM to power supply sense terminals.
- DVM and front-panel voltmeter should both indicate 60 V.

**5-16 Load Effect (Load Regulation).**

Definition: The change in the static value of dc output voltage ( $\Delta E_{OUT}$ ) resulting from a change in load resistance from open circuit to a value which yields maximum rated output current, or from the latter value to open circuit.

5-17 To check the constant-voltage load effect, proceed as follows:

- Connect test setup shown in Figure 5-2.
- Turn on supply and turn up output voltage. If unit switches to CC LIMIT mode, use OUTPUT ADJUST controls to increase CC limit so that unit remains in CV mode.
- Adjust output voltage until DVM indicates 20 V.
- Disconnect DVM from power supply sense terminals and connect DVM across  $R_M$ .
- Adjust resistance of  $R_L$  until DVM reads 0.1 V, indicating that current output is exactly 10 A (maximum rated output current). Ensure that power supply remains in constant-voltage mode.
- Disconnect DVM from  $R_M$  and reconnect DVM to power supply sense terminals.
- Open switch S1 to disconnect load.
- Record voltage indicated on DVM.
- Close switch S1 to reconnect load.
- Wait a few seconds only to allow DVM to settle. Reading on DVM should not differ from reading of step h by more than 5 mV.

**5-18 Source Effect (Line Regulation).**

Definition: The change in the static value of dc output voltage ( $\Delta E_{OUT}$ ) resulting from a change in ac input voltage over the specified range from low line to high line, or from high line to low line.

5-19 To check the source effect, proceed as follows:

- Connect test setup shown in Figure 5-2.

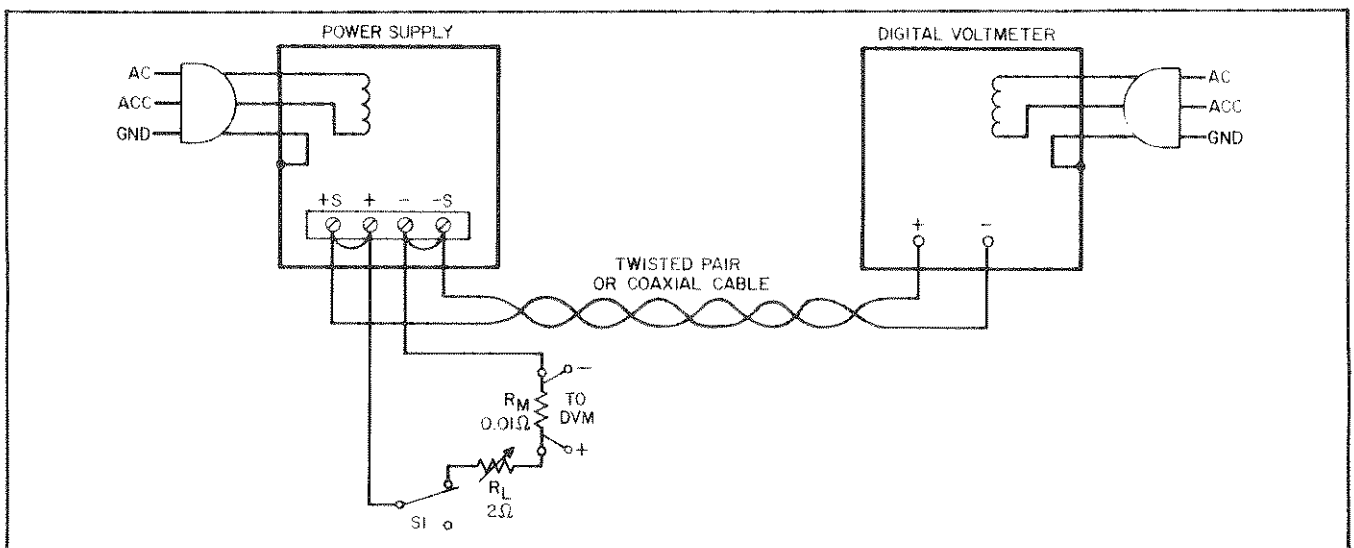

Figure 5-2. Constant-Voltage Test Setup

- b. Connect variable autotransformer between input power source and power supply ac power input.
- c. Adjust autotransformer for low line voltage (paragraph 2-20).
- d. Turn on supply and turn up output voltage. If unit switches to CC LIMIT mode, use OUTPUT AJDUST controls to increase CC limit so that unit remains in CV mode.
- e. Adjust output voltage until DVM indicates exactly 60 V.
- f. Disconnect DVM from power supply sense terminals and connect DVM across  $R_M$ .
- g. Adjust resistance of  $R_L$  until DVM reads 33 mV, indicating that current output is exactly 3.3 A. Ensure that power supply remains in CV mode.
- h. Disconnect DVM from  $R_M$  and reconnect DVM to power supply sense terminals.
- i. Record voltage indicated on DVM.
- j. Adjust autotransformer for high line voltage.
- k. Reading on DVM should not differ from reading of step i by more than 4 mV.

### 5-20 PARD (Ripple and Noise).

Definition: The residual ac voltage superimposed on the dc output of a regulated power supply. Ripple and noise measurements may be made at any input ac line voltage combined with any dc output voltage and current within the supply's rating.

5-21 The amount of ripple and noise present on the power supply output is measured either in terms of its rms or (preferably) peak-to-peak value. The peak-to-peak measurement is particularly important for applications where noise spikes could be detrimental to sensitive loads such as logic circuitry. The rms measurement is not an ideal representation of the noise, because fairly high output noise spikes of short duration can be present in the ripple without appreciably increasing the rms value.

5-22 **Ripple Measurement Techniques.** Figure 5-3A shows a method of measuring ripple using a single-ended true-reading RMS voltmeter or oscilloscope. The power supply output terminals should not be connected to ground at the power supply terminal strip to prevent current from flowing through a ground loop and adding to the measured signal. Also, to ensure that no potential difference exists between the supply and the RMS voltmeter, it is recommended that they both be plugged into the same ac power bus. If the same bus cannot be used, both ac grounds must be at earth ground potential.

5-23 To minimize pickup, a twisted pair or (preferably) a shielded cable should be used to connect the sensing terminals of the power supply to the input of the RMS voltmeter. The common mode choke is recommended to minimize potential interference of common mode noise with the ripple measurement. To verify that the RMS voltmeter is not

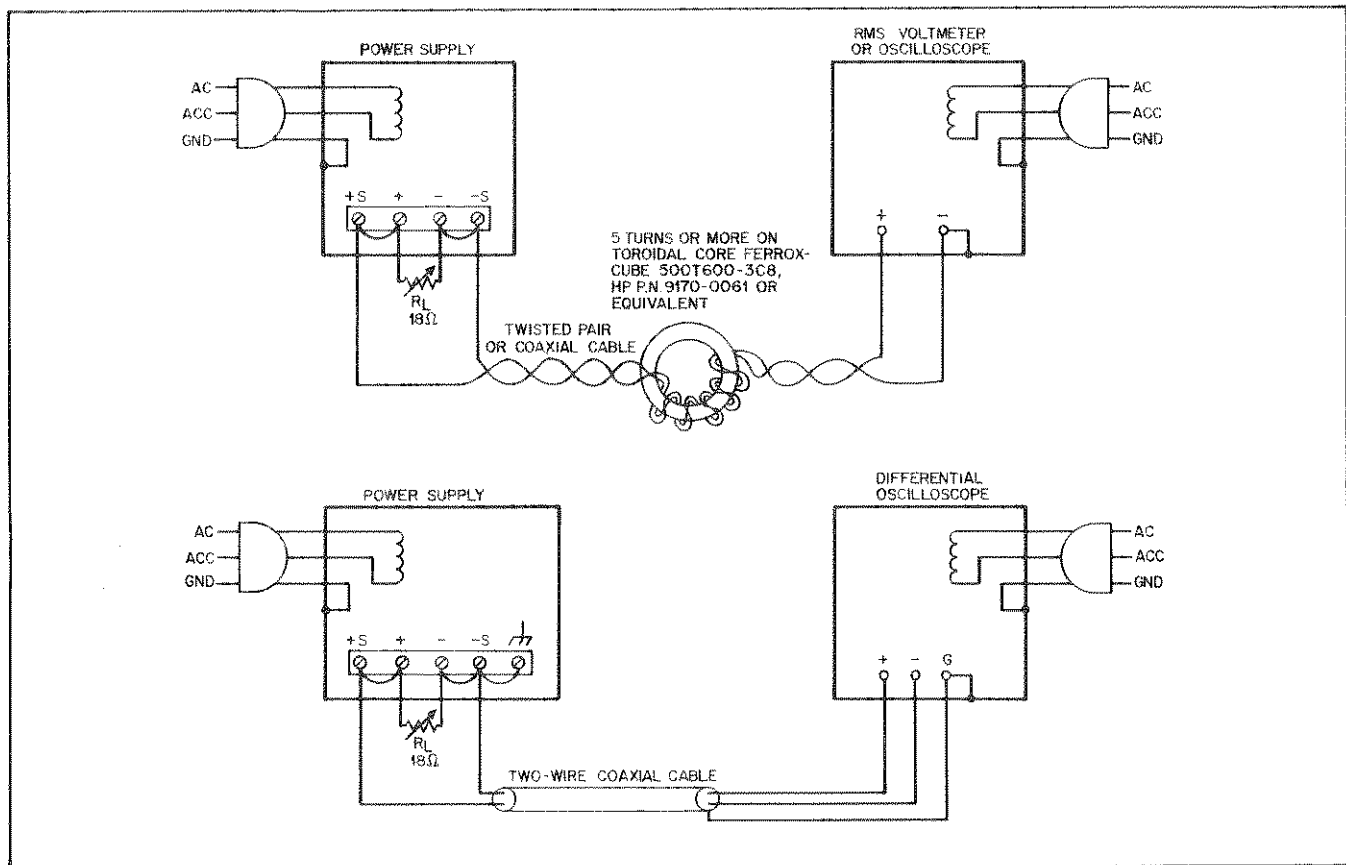

Figure 5-3. Constant-Voltage Ripple Test Setup

measuring ripple that is induced in the leads or picked up from ground, short the voltmeter + sense lead to the voltmeter - sense lead at the power supply output terminals. If the test setup is properly configured, the noise value obtained when the leads are shorted should not be significant compared to the measured ripple value.

**5-24** In some cases it may be desirable to use a differential oscilloscope to display ripple, as shown in Figure 5-3B. Because of its common-mode rejection, a differential oscilloscope displays only the difference in signal between its two vertical input terminals, thus ignoring the effects of any common-mode signal produced by the difference in the ac potential between the power supply case and the oscilloscope case. Before using a differential-input oscilloscope, however, it is imperative that the common-mode-rejection capability of the oscilloscope be verified by shorting together its two input leads at the power supply and observing the trace on the CRT. If the trace is a straight line, then the oscilloscope is properly ignoring any common-mode signal present. If the trace is not a straight line, then the oscilloscope is not rejecting the ground signal and must be realigned in accordance with the manufacturer's instructions so that proper common-mode rejection is attained.

**5-25 Ripple Measurement Procedure.** To check the ripple output, proceed as follows:

- Connect one of the test setups shown in Figure 5-3.
- Turn on supply and turn up output voltage. If unit switches to CC LIMIT mode, use OUTPUT ADJUST controls to increase CC limit so that unit remains in CV mode.
- Adjust output voltage and  $R_L$  so that front-panel meters indicate 40 V and 5.7 A.
- Ripple should be less than 3mV.

**5-26 Noise Spike Measurement Techniques.** An instrument of sufficient bandwidth must be used when making a high-frequency spike measurement. An oscilloscope with a bandwidth of 20 MHz or more is adequate. Measuring noise with an instrument that has insufficient bandwidth may conceal high-frequency spikes that could be detrimental to the load.

**5-27** A single-ended measurement (replacing rms voltmeter in Figure 5-3A with an oscilloscope) is usually not adequate for measuring spikes; a differential oscilloscope is necessary. The common-mode-rejection capability of the oscilloscope must be verified as described in Paragraph 5-24.

**5-28** Figure 5-4 shows the test setup used to measure noise spikes. Two coaxial cables must be used. Impedance-matching resistors must be included to eliminate standing waves and cable ringing, and capacitors must be connected to block dc. The length of the test leads outside the coaxial cable should be kept as short as possible. The blocking capacitor and impedance-matching resistor should be connected directly from the inner conductor of the cable to the power supply sensing terminal. Notice that the shields of the two coaxial cables are not connected to the power supply, because such a connection would provide a ground current path through the coaxial shield and result in an erroneous measurement.

**5-29 Noise Spike Measurement Procedure.** To check the noise spikes, proceed as follows:

- Connect the test setup shown in Figure 5-4.
- Turn on supply and turn up output voltage. If unit switches to CC LIMIT mode, use OUTPUT ADJUST controls to increase CC limit so that unit remains in CV mode.

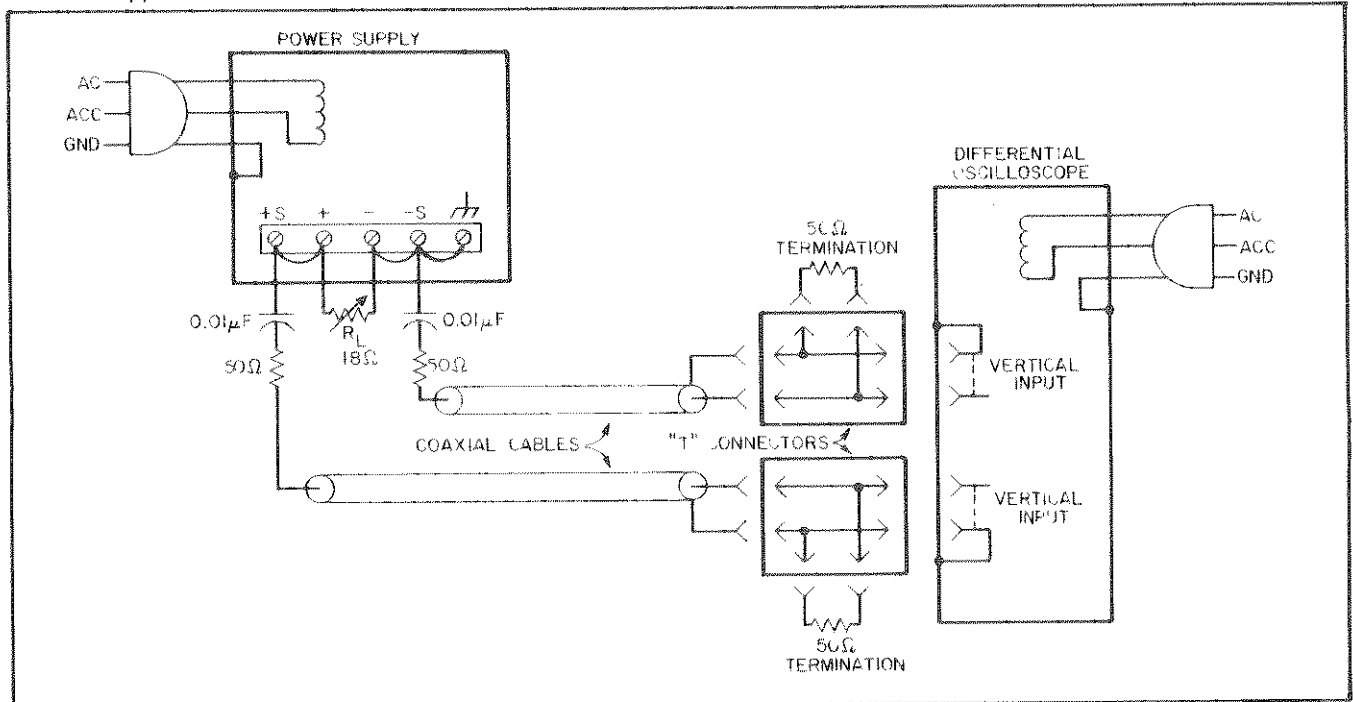

Figure 5-4. Constant-Voltage Noise Spike Measurement Setup

- c. Adjust output voltage and  $R_L$  so that front-panel meters indicate 60 V and 3.3 A.
- d. Because the impedance-matching resistors constitute a 2-to-1 attenuator, the noise spikes observed on the oscilloscope should be less than 15 mV p-p (instead of 30 mV p-p).

5-30 The circuit of Figure 5-4 can also be used for the display of low-frequency ripple. Simply remove the four terminating resistors and the blocking capacitors and substitute a high-gain vertical plug-in for the wide-band plug-in required for spike measurements.

### 5-31 Load Transient Recovery Time.

Definition: The time "X" for output voltage recovery to within "Y" millivolts of the nominal output voltage following a "Z" amp step change in load current, where: "Y" is specified as 75 mV; the nominal output voltage is defined as the dc level halfway between the static output voltage before and after the imposed load change; and "Z" is the specified load current change of from 90% to 100% (or vice-versa) of maximum current rating.

5-32 **Measurement Techniques.** Care must be taken in switching the load resistance on and off. A hand-operated switch in series with the load is not adequate since the resulting one-shot displays are difficult to observe on most oscilloscopes and the arc energy occurring during switching completely masks the display with a noise burst. Transistor load switching devices are expensive if reasonably rapid load current changes are to be achieved.

5-33 We suggest that a mercury-wetted relay connected in the load switching circuit shown in Figure 5-5 be used for loading and unloading the supply. When this load switch is connected to a 60 Hz ac input, the mercury-wetted relay opens and closes 60 times per second. The 25 k control adjusts the duty cycle of the load current switching to reduce jitter in the oscilloscope display. This relay may also be used with a 50 Hz ac input.

5-34 **Measurement Procedure.** To check the load transient recovery time, proceed as follows:

- a. Connect load resistor  $R_L$  (Figure 5-5) across output of supply. Do not connect  $R_{L2}$  and load switch at this time.
- b. Turn on supply and adjust output voltage for 20 V on front-panel meter. If unit switches to CC LIMIT mode, use OUTPUT ADJUST controls to increase CC limit so that unit remains in CV mode.
- c. Adjust  $R_{L1}$  for approximately 2.22  $\Omega$  (9A on front-panel current meter). Increase CC limit as necessary so that unit remains in CV mode.
- d. Turn off supply and connect  $R_{L2}$  in parallel with  $R_{L1}$ . Do not connect load switch yet.
- e. Turn on supply and adjust output voltage to 20 V. Increase CC limit as necessary so that unit remains in CV mode.
- f. Set  $R_{L2}$  for approximately 20.2  $\Omega$  (20  $\Omega$  total resistance across supply) by adjusting  $R_{L2}$  until 6034A output

is 20 V and 10 A. Increase CC limit as necessary so that unit remains in CV mode.

- g. Turn off supply and connect load switch and load resistors as shown in Figure 5-5.
- h. Turn on supply and adjust output to 20 V and 10 A.
- i. Close line switch on repetitive load switch setup.
- j. Set oscilloscope for internal sync and lock on either the positive or negative load transient spike.
- k. Set vertical input of oscilloscope for ac coupling so that small dc level changes in power supply output voltage will not cause display to shift.
- l. Adjust the vertical centering on the scope so that the tail ends of the low-load and full-load waveforms are symmetrically displaced about the horizontal centerline of the oscilloscope. The centerline now represents the nominal output voltage defined in the specification.
- m. Adjust the horizontal positioning control so that the trace starts at a major graticule division. This point then represents time zero.
- n. Increase the sweep rate so that a single transient spike can be examined in detail.
- o. Adjust the sync controls separately for the positive and negative-going transients so that not only the recovery waveshape but also as much as possible of the rise time of the transient is displayed.
- p. Starting from the major graticule division representing time zero, count to the right 1mS and vertically 75 mV, recovery should be within these tolerances as illustrated in Figure 5-6.

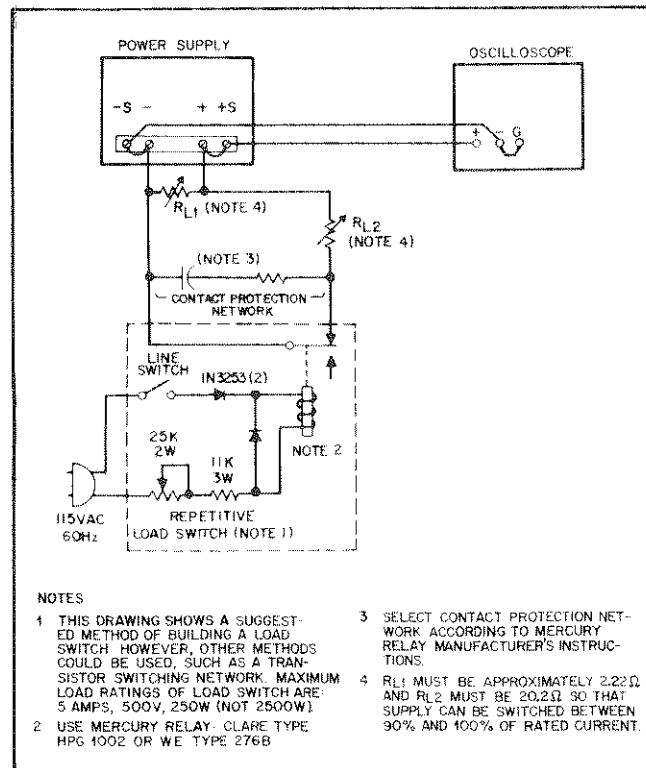

Figure 5-5. Load Transient Recovery Time Test Setup

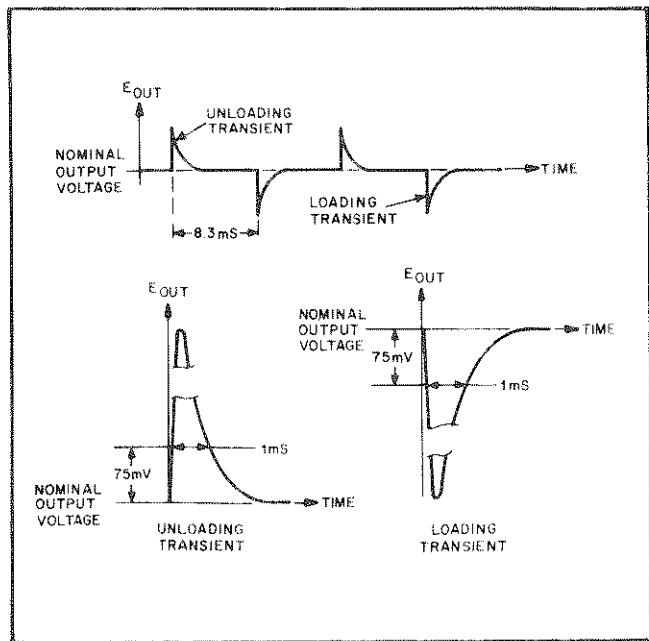

Figure 5-6. Load Transient Recovery Waveforms

#### 5-35 Temperature Coefficient.

Definition: The change in output voltage per $^{\circ}\text{C}$  change in ambient temperature measured while ac line voltage, output voltage setting, and load resistance are all held constant.

5-36 The temperature coefficient of a power supply is measured by placing the unit in an oven and varying the temperature over any span within the power supply's rating. The power supply temperature must be allowed to stabilize for a sufficient time at each measurement temperature.

5-37 The temperature coefficient given in the specification table is the maximum temperature-dependent output voltage change which will result over any one-degree interval. The digital voltmeter used to measure the supply's output voltage change should be placed outside the oven and should have a long-term stability adequate to insure that its drift will not affect the overall measurement accuracy.

5-38 To check the temperature coefficient, proceed as follows:

- Connect load resistance and digital voltmeter as illustrated in Figure 5-2.
- Turn on supply and turn up output voltage. If unit switches to CC LIMIT mode, use OUTPUT ADJUST controls to increase CC limit so that unit remains in CV mode.
- Adjust output voltage until DVM indicates exactly 60 V (maximum rated output voltage).
- Disconnect DVM from power supply sense terminals and connect DVM across current-monitoring resistor ( $R_M$ ).
- Reduce resistance of  $R_L$  until DVM reads 33 mV, indicating that current output is exactly 3.3 A (maximum rated power output). Ensure that power supply remains in CV mode.

- Disconnect DVM from  $R_M$  and reconnect DVM to power supply sense terminals.
- Place power supply in temperature-controlled oven (DVM remains outside oven). Set temperature to  $30^{\circ}\text{C}$  and allow 30 minutes warm-up.
- Record DVM reading.
- Raise Temperature to  $40^{\circ}\text{C}$  and allow 30 minutes warm-up.
- Observe DVM reading. Difference in voltage reading between steps h and j should be less than 70 mVdc.

#### 5-39 Drift (Stability).

Definition: The change in output voltage for the first eight hours following a 30-minute warm-up period. During the interval of measurement, input line voltage, load resistance and ambient temperature are all held constant.

5-40 This measurement is made by monitoring the output of the power supply on a digital voltmeter over the stated measurement interval. A strip chart recorder can be used to provide a permanent record. Place a thermometer near the supply to verify that the ambient temperature remains constant during the period of measurement. The supply should be located away from any source of stray air current. If possible, place the supply in an oven and hold it at a constant temperature. Take care that the measuring instrument has an eight-hour stability at least an order of magnitude better than the stability specification of the power supply being tested. Typically, a supply will drift less over the eight-hour measurement interval than during the half-hour warm-up period.

5-41 To check the output stability, proceed as follows:

- Connect load resistance and digital voltmeter (DVM) as illustrated in Figure 5-2.
- Turn on supply and turn up output voltage. If unit switches to CC LIMIT mode, use OUTPUT ADJUST controls to increase CC limit so that unit remains in CV mode.
- Adjust output voltage until DVM indicates exactly 60 V (maximum rated output voltage.)
- Disconnect DVM from power supply sense terminals and connect DVM across current-monitoring resistor ( $R_M$ ).
- Reduce resistance of  $R_L$  until DVM reads 33 mV, indicating that the current output is exactly 3.3 A (maximum rated power output). Ensure that power supply remains in CV mode.
- Disconnect DVM from  $R_M$  and reconnect DVM to power supply sense terminals.
- Allow 30 minutes warm-up, and then record DVM reading.
- After eight hours, DVM reading should not differ from reading of step g by more than 21 mVdc.

#### 5-42 Constant-Current Tests

5-43 The instruments, methods, and precautions for the proper measurement of constant-current power supply characteristics are for the most part identical to those already described for the measurement of constant-voltage

characteristics. The main difference is that the power supply performance will be checked between short circuit and full load rather than open circuit and full load.

**5-44 Current Output and Current Meter Accuracy.** To check that the supply will furnish its rated output current, proceed as follows:

- Connect test setup shown in Figure 5-7. Set  $R_L$  to minimum resistance initially.
- Turn on supply and turn up output voltage. Set OUTPUT ADJUST controls to adjust output current until DVM reads 0.1 V, indicating that output current is exactly 10 A (maximum rated output current). If unit switches to CV mode, use OUTPUT ADJUST controls to increase CV limit so that unit remains in CC mode.
- Front-panel ammeter should indicate 10 A.
- Disconnect DVM from  $R_M$  and connect DVM to power supply sense terminals.
- Increase resistance of  $R_L$  until DVM reads exactly 20 V (maximum rated power output). Ensure that power supply remains in CC mode.
- Disconnect DVM from power supply sense terminals and reconnect DVM across  $R_M$ .
- DVM should indicate 0.1 V; front-panel ammeter should indicate 10 A.

**5-45 Load Effect (Load Regulation).**

Definition: The change in the static value of the dc output current ( $\Delta I_{OUT}$ ) resulting from a change in load resistance from short circuit to a value which yields maximum rated output voltage, or from the latter value to short circuit.

**5-46** To check the constant-current load effect, proceed as follows:

- Connect test setup shown in Figure 5-7.
- Turn on supply and turn up output voltage. Set OUTPUT ADJUST controls to adjust output current until DVM reads 33mV, indicating that output current is exactly 3.3 A. If unit switches to CV mode, use OUT-

PUT ADJUST controls to increase CV limit so that unit remains in CC mode.

- Disconnect DVM from  $R_M$  and connect DVM to power supply sense terminals.
- Adjust resistance of  $R_L$  until DVM indicates 60 V (maximum rated output voltage). Ensure that power supply remains in constant-current mode.
- Disconnect DVM from power supply sense terminals and reconnect DVM to  $R_M$ .
- Record voltage indicated on DVM.
- Close switch to short circuit load.
- Wait a few seconds only to allow DVM to settle. Reading on DVM should not differ from reading of step f by more than  $33\mu V$ .

**5-47 Source Effect (Line Regulation).**

Definition: The change in the static value of dc output current ( $\Delta I_{OUT}$ ) resulting from a change in ac input voltage over the specified range from low line to high line, or from high line to low line.

**5-48** To check source effect, proceed as follows:

- Connect test setup shown in Figure 5-7.
- Connect variable autotransformer between input power source and power supply ac power input.
- Adjust autotransformer for low line voltage (paragraph 2-20).
- Turn on supply and turn up output voltage. Set OUTPUT ADJUST controls to adjust output current until DVM reads 0.1 V, indicating that output current is exactly 10 A (maximum rated output current). If unit switches to CV mode, use OUTPUT ADJUST controls to increase CV limit so that unit remains in CC mode.
- Disconnect DVM from  $R_M$  and connect DVM to power supply sense terminals.
- Adjust resistance of  $R_L$  until DVM reads exactly 20 V. Ensure that power supply remains in constant-current mode.
- Disconnect DVM from power supply sense terminals and reconnect DVM across  $R_M$ .

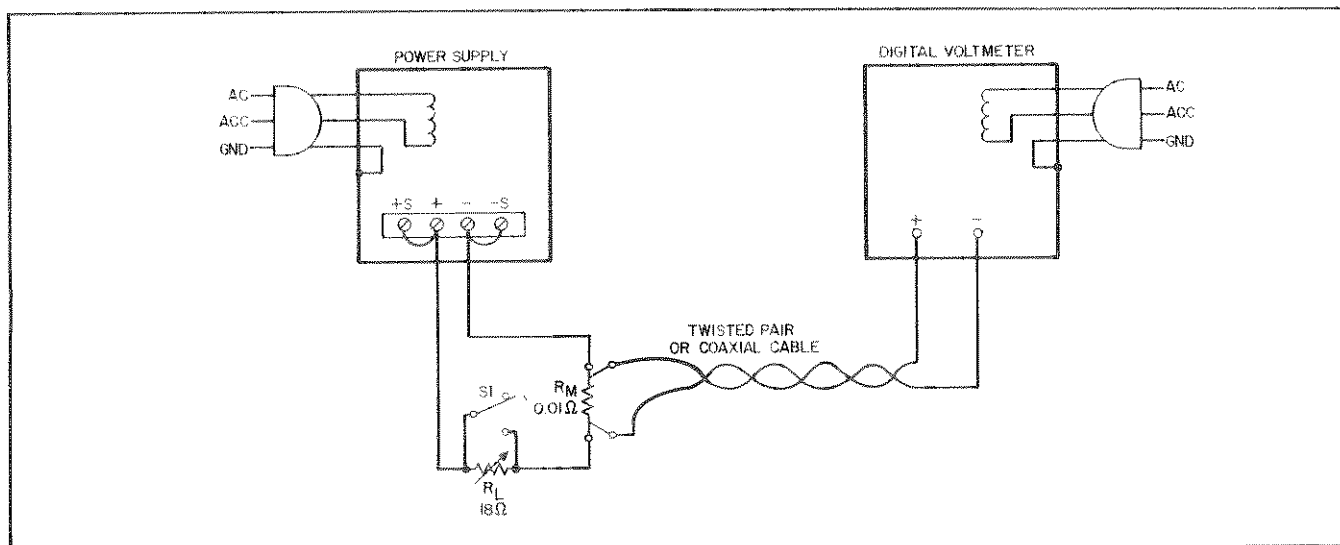

Figure 5-7. Constant-Current Test Setup



- h. Record voltage indicated on DVM.
- i. Adjust autotransformer for high line voltage.
- j. Reading on DVM should not differ from reading of step h by more than  $30\mu\text{V}$ .

**5-49 PARD (Ripple and Noise).**

Definition: The residual ac current superimposed on the dc output of a regulated power supply. Ripple and noise measurement may be made at any input ac line voltage combined with any dc output voltage and load current within the supply's rating.

5-50 Most of the instructions pertaining to pickup problems associated with constant-voltage ripple and noise measurement also apply to the measurement of constant-current ripple and noise. Figure 5-8 shows two test setups that can be used when measuring the ripple and noise of a constant-current supply. Either test setup can be used depending on the availability of an appropriate monitoring resistor.

5-51 The current-monitoring resistor ( $R_M$ ) in Figure 5-8 can be constructed of parallel-connected resistors. It must have very low inductance to prevent the high frequency components of CC ripple from causing a misleading voltage drop. A current probe/amplifier combination such as Tektronix P6302 probe and AM503 amplifier can be used for the current-monitoring transformer (T1) in Figure 5-8B.

- 5-52 To check the ripple and noise, proceed as follows:
- a. Connect oscilloscope or rms voltmeter as shown in Figure 5-8.
  - b. Turn on supply and turn up output voltage. Adjust output current and  $R_L$  until front-panel meters indicate 10 A and approximately 20 V. If unit switches to CV mode, use OUTPUT ADJUST controls to increase CV limit so that unit remains in CC mode.
  - c. The observed ripple and noise should be less than 0.5 mV rms (5 mA rms).

**5-53 TROUBLESHOOTING**

**5-54 Introduction**

5-55 The following paragraphs describe use of self tests which the 6034A can perform to verify the operation of many of its circuits, signature analysis, and the detailed troubleshooting trees. Also described is an optional service package. The procedures described in these paragraphs are designed to help a technician identify and locate any faults in the 6034A as rapidly as possible. A good understanding of the principles of operation is particularly helpful, and it is recommended that Section IV of this manual be reviewed before at-

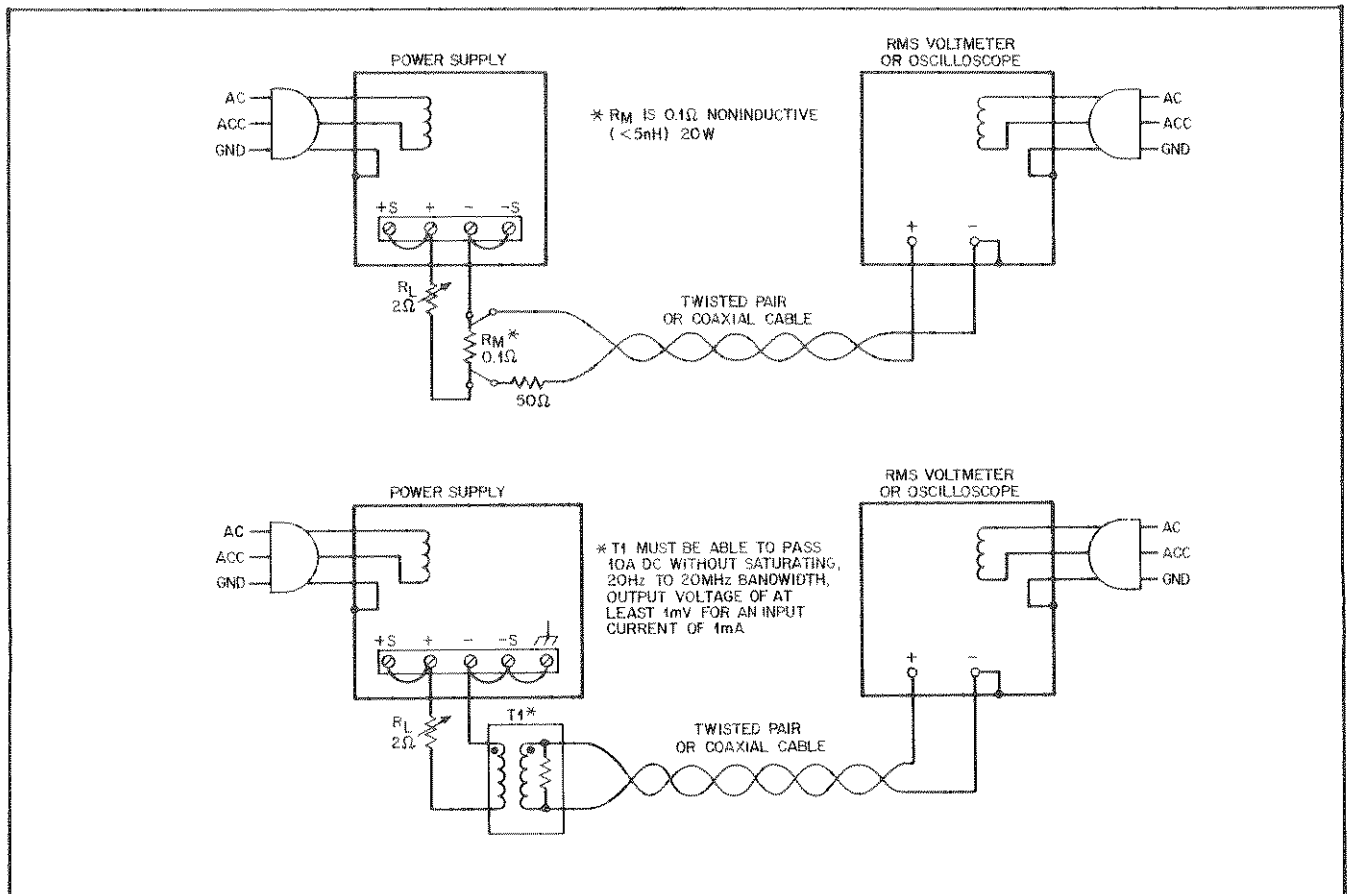

Figure 5-8. Constant-Current Ripple and Noise Measurement Test Setup

tempting to troubleshoot the unit. The following troubleshooting procedures will not check the calibration of the unit, which can be done with the performance tests given in the beginning of this section.

5-56 Section VII contains schematic diagrams and component location diagrams to help the user locate components and test points. Most test points for the power mesh and control board are located on the control board test "fingers", which are readily accessible at the top of the board. An extender board, HP part number 06024-60024, can be used with the control board to allow easy access to components. A test connector, HP part number 1251-6016, allows easy connection of test probes to the test fingers. Test points on the HP-IB/microcomputer board consists of stand-up pins to which test probes can be clipped. Wire loops on the front-panel printed-circuit board and the HP-IB/microcomputer board allows connection of test probes to various reference voltages.

### 5-57 Initial Procedures

5-58 If the 6034A appears to be malfunctioning, perform the following steps before beginning the formal troubleshooting procedures.

- Check that input power is available, and check the power cord and rear-panel line fuse. When replacing line fuse, be certain to select fuse of proper rating for line voltage being used.
- Check that straps on the rear-panel terminal block are properly connected.
- Check that all connections to the power supply are secure and that circuits between the supply and other devices are not interrupted.
- Check that the rear-panel HP-IB address switches are set properly.
- If the 6034A fails turn-on self test or gives any other indication of malfunction, remove the unit from the operating system before proceeding with further testing.

5-59 **Optional Service Package.** Because the 6034A microcomputer performs the self tests described in the following paragraphs, it can test only those circuits to which it has access, and the most thorough tests are performed on circuits functionally closest to the microprocessor. A service software package is available to supplement the self tests by performing some tests and guiding the user through other tests that cannot be accomplished by the microcomputer, such as tests of the HP-IB interface circuits. In addition, the cassette tape provided in the software package performs many of the steps in the troubleshooting trees faster and easier than they can be performed by the user via the computer keyboard.

5-60 Order HP part number 06034-10001 for use with the HP 9825 computer, or HP part number 06034-10002 for use with the HP 85 computer. Each service software package includes an instruction booklet.

### 5-61 Self Test and Test Mode

5-62 The 6034A performs a self test of its RAM, real-time clock, and ROM circuits each time power is turned on. More extensive self tests can be accessed in test mode. If the unit fails any of these tests, the SELF TEST LED remains on and the other front-panel LEDs light in specific codes to indicate the nature of the failure. The four LEDs to the left of the meter display, RMT, LSN, TLK, and SRQ, indicate which test failed according to the code in Figure 5-9. The OVP, OTP, and UNREGULATED LEDs, below the meter display, indicate which section of the test failed, see Figure 5-9. Table 5-2 gives a brief description of each test and each fault within the tests, and suggests possible causes of failure.

#### NOTE

*It should be remembered that the possible fault areas provided in Table 5-2 are considered the most likely, but the list is not necessarily complete.*

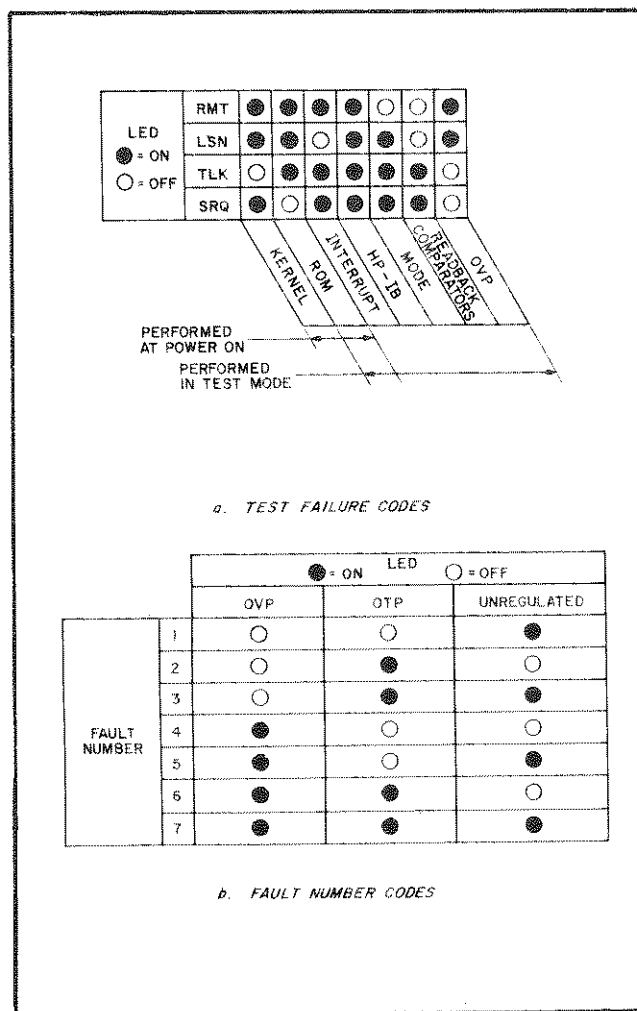

Figure 5-9. Self Test Error Codes

Table 5-2. Self Test Error Descriptions

FAULT #	DESCRIPTION
<p>1 2 3 4 7</p> <p>5 6</p>	<p>KERNEL TEST (consists of RAM tests and real-time clock tests.) The RAM test is the first test performed when power is applied to the 6034A. It is executed only once, and only at power on. RAM test is not performed while the 6034A is in test mode, nor may test mode be invoked if the RAM test fails.</p> <p>RAM 1* (A4U32) failed uniqueness test.</p> <p>RAM 2 (A4U33) failed uniqueness test.</p> <p>RAM 1* failed walking 1s and 0s test.</p> <p>RAM 2 failed walking 1s and 0s test.</p> <p>Either RAM failed initial data retention test.</p> <p>Possible Fault Areas: RAMs may have failed, or address bus, address decoders, or associated circuits may have failed.</p> <p>*If both RAMs are at fault, only RAM 1 will be reported.</p> <p>The real-time clock test is performed upon proper completion of the RAM test. It is executed only once, and only at power on. Real-time clock test is not performed while the 6034A is in test mode, nor may test mode be invoked if the real-time clock test fails. The real importance of this test is that it tests an input port without the microprocessor providing the stimulus.</p> <p>Line frequency measures greater than 65 Hz.</p> <p>Line frequency measures less than 45 Hz.</p> <p>Possible Fault Areas: Because it is unlikely that ac line frequency is outside 45-65 Hz range, line sensing circuit may have failed or microcomputer CRUIN circuits may be malfunctioning. If this test passes, microcomputer CRUIN circuits can be assumed to be operating properly.</p> <p>ROM TEST. The ROM test is performed at power on upon successful completion of the kernel tests. Failure of the ROM test at power on does not prevent the user from returning the 6034A to normal operation. The ROM test is also performed when test mode is invoked and self tests are selected (6034A turns on in self test when test mode is invoked).</p>
<p>1 2 3</p>	<p>ROM 1 (A4U25) checksum incorrect.*</p> <p>ROM 2 (A4U90) checksum incorrect.*</p> <p>ROM 3 (A4U24) checksum incorrect.*</p> <p>Possible fault areas: The ROM or its chip select may have failed, or address bus, data bus, or associated circuits may have failed.</p> <p>*In units with three EPROMs instead of one ROM, if more than one ROM fails, only the lowest numbered will be reported.</p>
<p>1 3 4 5 6</p>	<p>INTERRUPT SYSTEM TEST. The interrupt system test is performed when test mode has been invoked and self tests are selected. It is not performed at power on.</p> <p>Power mesh interrupt did not occur when expected. This test inhibits the power mesh PWM clock, which should cause the supply to become unregulated.</p> <p>Possible fault areas: Fault is probably in power mesh; disable signal may be lost between front-panel latch and power mesh PWM disable gate. A fault in interrupt circuit or interrupt enable could also be the cause.</p> <p>Timer interrupt did not occur.</p> <p>Possible fault areas: Fault is probably in 1 ms timer circuit or interrupt circuit.</p> <p>Power mesh interrupt occurred when it should not.</p> <p>Possible fault areas: Fault is probably located in the interrupt circuit or the output port involved with interrupt enable signal.</p> <p>HP-IB interrupt occurred when it should not.</p> <p>Possible fault areas: Fault is probably located in the interrupt circuit or the HP-IB circuits.</p> <p>Timer interrupt signal occurs, but elapsed time is wrong.</p> <p>Possible fault areas: Fault is probably located in 1 ms timer circuit.</p>

Table 5-2. Self Test Error Descriptions (cont.)

FAULT #	DESCRIPTION
<p>1</p> <p>1</p> <p>2</p> <p>3</p> <p>4</p> <p>5</p> <p>6</p> <p>7</p>	<p>HP-IB INTERFACE TEST. The HP-IB interface test is performed when test mode has been invoked and self tests are selected. It is not performed at power on.</p> <p>Data read in from shift register does not agree with data previously loaded into shift register.</p> <p>Possible fault areas: The CRUIN and/or CRUOUT opto-isolators may have failed, or the data shifters or the circuits that generate the data shifter control signals may be at fault. This test will not check CHI or any of the HP-IB monitor circuits.</p> <p>POWER MESH MODE TEST. The power mesh mode test is performed when test mode has been invoked and self test are selected. It is not performed at power on. This test will fail if the power supply output terminals are not open. In the following list of faults, the first two entries on each line indicate the conditions which the microcomputer set up, and the last entries indicate the unexpected result.</p> <p><math>\overline{M2} = 1, \overline{CV} = 0</math>, but M2 ANDed with CV = 1</p> <p><math>\overline{M1} = 0, \overline{CC} = 1</math>, but M1 ANDed with CC = 1</p> <p><math>\overline{M2} = 0, \overline{CV} = 0</math>, but M2 ANDed with CV = 0</p> <p><math>\overline{M1} = 1, \overline{CC} = 1</math>, but M1 ANDed with CC = 1</p> <p><math>\overline{CV} = 1, \overline{CC} = 1</math>, but Unregulated = 0</p> <p><math>\overline{M1} = 0, \overline{CC} = 1</math>, but M1 ANDed with CC = 1</p> <p><math>\overline{M1} = 0, \overline{CC} = 1</math>, but M1 ANDed with CC = 1</p> <p>Possible fault areas: Although the signals could be lost in the microcomputer circuit or front-panel gates, latches, or connectors, the most likely cause is damage to the power mesh.</p>
<p>1</p> <p>3</p> <p>4</p>	<p>READBACK COMPARATORS TEST. The readback comparators test is performed when test mode has been invoked and self tests are selected. It is not performed at power on. This test will fail if the power supply output terminals are not open.</p> <p>CC reference &gt; I out, but CC comparator output low.</p> <p>CV reference &gt; V out, but CV comparator output low.</p> <p>CV reference &lt; V out, but CV comparator output high.</p> <p>Possible fault areas: If this is the only test that failed, the fault is probably in the CV or CC comparators or associated circuitry. If other power mesh tests also failed, fault is probably in power mesh.</p>
<p>1</p> <p>2</p> <p>3</p> <p>4</p> <p>5</p>	<p>OVP TEST. The OVP test is performed when test mode has been invoked and self tests are selected. It is not performed at power on. This test will cause the power supply output voltage to rise to 60 volts, so the output terminals must be open to prevent damage to sensitive loads. The test may fail if the power supply output terminals are not open.</p> <p>OVP status indicator false when it should be true.</p> <p>OVP status indicator true when it should be false.</p> <p>Zero volts output and 64.5 volts OVP trip point are programmed, but OVP will not reset.</p> <p>Three volts output and two volts OVP trip point are programmed, but OVP will not trip.</p> <p>60 volts output and 64.5 volts OVP trip point are programmed, but OVP will not reset.</p> <p>Possible fault areas: If this is the only test that failed, fault is probably in the OVP circuit. If other power mesh tests failed, fault is probably in power mesh.</p>

5-63 For most failures the front-panel LED indicators (except SELF TEST) will flash on and off. Flashing indicators always indicate a fault, but, because flashing is controlled by the microcomputer, a failure in the kernel of the microcomputer may cause the indicators to remain on in code without flashing.

### NOTE

*Because the unit is testing itself, it is not possible to guarantee that the unit will provide an unambiguous indication of all possible failures. For example, a failure in the hardware used for self test or in the core of the microprocessor may prevent the unit from indicating that it has not passed self test. If the unit appears to be inoperative, but it does not indicate failure of self tests, it should be removed from the operating system and the user should follow the procedures given in the main troubleshooting tree, Figure 5-16.*

5-64 Passing all self tests indicates that the 6034A can function at least partially. Self test cannot verify the HP-IB interface without use of a computer, nor can it verify the front-panel controls without someone to operate them. This type of check can be performed with use of the optional service software package. Also, self tests cannot check calibration or whether the power mesh can provide full power output. For these checks, use the performance tests given in the beginning of this section.

5-65 Self tests can help eliminate some circuits as fault locations, and they can help locate a fault to certain circuits, but self tests generally will not indicate reasons for a fault. Users without extensive 6034A experience are advised to use the troubleshooting trees and follow all procedures step by step.

5-66 Test mode also enables use of signature analysis techniques for troubleshooting, and it allows testing of the front-panel LEDs. Table 5-3 shows the status of various LEDs for each of the test mode conditions.

5-67 The following paragraphs describe use of each of the diagnostic and troubleshooting procedures provided with the 6034A.

5-68 **Turn-On Self Test.** The self tests performed at turn-on takes less than one second to complete, and all front-panel indicators are on while the tests are in progress. If the unit is not in test mode and it passes the tests, the front-panel indicators will turn off and the unit will be ready for operation. The SRQ indicator will remain on until the unit is serial polled in response to its power-on service request. If the unit fails the tests, refer to Figure 5-9 to decode the reason for the failure. Proceed to the main troubleshooting tree, Figure 5-16. Note that the unit will not respond to a serial poll if it fails turn-on self test, even though the unit will set SRQ.

5-69 **Test Mode Self Tests.** To access the additional self test available in test mode, proceed as follows:

- a. Turn off the 6034A.
- b. Disconnect all loads from the 6034A output terminals and disconnect the 6034A from the HP-IB.



*Output voltage will rise to 60 volts during part of the test mode self tests. In addition to the personal hazard of this potential, a voltage-sensitive load attached to the output terminals may be damaged, and the 6034A will fail self tests. In addition, the controller may get hung up waiting for the 6034A to respond. Do not invoke test mode with the 6034A on line in an operating system.*

- c. Connect the sense terminals for local sensing if they are not already so connected.
- d. Press the OUTPUT ADJUST pushbutton switch while turning on the 6034A. Continue to press the OUTPUT ADJUST switch for at least 2½ seconds but not more than 5 seconds after turn on. If the unit has entered test mode, the SELF TEST indicator and all segments of the VOLTS and AMPS displays will remain on after the OUTPUT ADJUST switch is released, and the VOLTAGE indicator will flash on and off to indicate that self tests are being performed. If the OUTPUT ADJUST switch is held for too long or not long enough, the unit will revert to normal operating mode (assuming it passes turn-on self tests).

Table 5-3. Test Mode LED Status

SELF TEST LED	VOLTAGE LED	CURRENT LED	ERROR-CODED LEDs*	Mode
On	Flashing	Off	Off	Running Self Tests
On	Off	Off	Flashing	Self Test Failed
On	Off	Flashing	Off	Signature Analysis
On	Off**	Off**	Off**	LED Test
Off	X	X	X	Normal Operation

\*RMT, LSN, TLK, SRQ, OVP, OTP, and UNREGULATED.

\*\*One LED may be on if RPG has been rotated.

**CAUTION**

*This instrument uses components which can be damaged by static charges. Most semiconductors can suffer serious performance degradation as a result of static charges, even though complete failure may not occur. The following precautions should be observed when handling static-sensitive devices.*

- a. Always turn power off before removing or installing printed-circuit boards.
- b. Always store or transport static-sensitive devices (all semiconductors and thin-film devices) in conductive material. Attach warning labels to the container or bag enclosing the device.
- c. Handle static-sensitive devices only at static-free work stations. These work stations should include special conductive work surfaces (such as HP Part No. 9300-0797) grounded through a one-megohm resistor. Note that metal table tops and highly conductive carbon-impregnated plastic surfaces are too conductive; they can act as large capacitors and shunt charges too quickly. The work surface should have distributed resistance of between  $10^6 \Omega$  and  $10^{12} \Omega$  per square.
- d. Ground all conductive equipment or devices that may come in contact with static-sensitive devices or sub-assemblies containing same.
- e. Where direct grounding of objects in the work area is impractical, a static neutralizer should be used (ionized-air blower directed at work). Note that this method is considerably less effective than direct grounding and provides less protection for static-sensitive devices.
- f. While working with equipment on which no point exceeds 500 volts, use a conductive wrist strap in contact with skin. The wrist strap should be connected to ground through a one-megohm resistor. A wrist strap with insulated cord and built-in resistor is recommended, such as 3M Co. No. 2066 (HP Part No. 9300-0969 [small] and 9300-0970 [large]).

**WARNING**

*Do not wear a conductive wrist strap when working with potentials in excess of 500 volts; the one-megohm resistor will provide insufficient current limiting for personal safety.*

- g. All grounding (device being repaired, test equipment, soldering iron, work surface, wrist strap, etc.) should be done to the same point.
- h. Do not wear nylon clothing. Keep clothing of any kind from coming within 12 inches of static-sensitive devices.
- i. Low-impedance test equipment (signal generators, logic pulsers, etc.) should be connected to static-sensitive inputs only while the components are powered.
- j. Use a mildly activated rosin core solder (such as Alpha Metal Reliacor No. 11, HP Part No. 8090-0098) for repair. The flux residue of this type of solder can be left on the printed-circuit board. Generally, it is safer not to clean the printed-circuit board after repair. Do not use Freon or other types of spray cleaners. If necessary, the printed-circuit board can be brushed using a natural-bristle brush only. *Do not use nylon-bristle or other synthetic-bristle brushes. Do not use high-velocity air blowers (unless ionized).*
- k. Keep the work area free of non-conductive objects such as Styrofoam-type cups, polystyrene foam, polyethylene bags, and plastic wrappers. Non-conductive devices that are necessary in the area can be kept from building up a static charge by spraying them with an anti-static chemical (HP Part No. 8500-3397).
- l. Do not allow long hair to come in contact with static-sensitive assemblies.
- m. Do not exceed the maximum rated voltages specified for the device.

5-70 The time window for entering test mode is delayed and short to minimize the possibility of test mode being invoked accidentally. Some of the tests cause a voltage across the output terminals, and this voltage could be hazardous if the user is unaware of test mode.

5-71 The six tests performed in test mode take approximately 16 seconds to complete, assuming the unit passes all tests. The tests will run continually until the user exits self test mode or a test fails. Note that the VOLTS display will change from 18.88 to 188.8 for approximately two seconds during each test cycle.

5-72 As long as the unit passes the self tests, the SELF TEST LED will remain on and the VOLTAGE LED will flash. If a test fails, the unit will stop self tests, the VOLTAGE LED turns off, and other front-panel indicators flash in code to indicate which test has failed. After noting which test failed and the fault number, press OUTPUT ADJUST once to continue self tests. The VOLTAGE LED will flash to indicate that self tests are running. If the unit fails another test, note the test failure and fault number codes and then press OUTPUT ADJUST once to continue self tests. When the unit stops a second time at the first test to have failed, the self test cycle has been completed.

5-73 The following paragraphs provide directions for switching from self test mode to signature analysis mode or LED test mode. To exit test mode completely and return the unit to normal operation, either press OUTPUT ADJUST pushbutton for at least three seconds or turn power off and then back on.

**5-74 Test Mode Signature Analysis.** To enter signature analysis mode, the unit must first be in test mode running self tests (VOLTAGE LED flashing). With the unit in test mode, press OUTPUT ADJUST once to switch the unit into signature analysis mode. The CURRENT LED will flash on and off to indicate that the unit is in signature analysis mode (SELF TEST LED remains on). Note that if the unit is in test mode self test and the test program has stopped at a failed test, OUTPUT ADJUST will have to be pressed twice rapidly, once to resume self test and once to switch the unit to signature analysis mode. If another self test fails before OUTPUT ADJUST is pressed the second time, try again; some of the self tests include a two-second settling time during which OUTPUT ADJUST can easily be pressed twice. The unit can also be forced into signature analysis mode by shorting test points TP11 and TP 14 together on the HP-IB/microcomputer assembly. To exit signature analysis mode, either press OUTPUT ADJUST once to enter LED test mode, twice to return to self test mode, or press OUTPUT ADJUST in for at least three seconds to return to normal operation.

5-75 Paragraph 5-82 provides a brief introduction to signature analysis and describes the use of signature analysis to troubleshoot the 6034A.

**5-76 LED Test Mode.** To enter LED test mode, the unit must first be in test mode. Press OUTPUT ADJUST twice to switch the unit into LED test mode (only once if unit is already in signature analysis mode). Only the SELF TEST LED will re-

main on. By rotating the OUTPUT ADJUST knob (RPG) in either direction, all LEDs will turn on sequentially. In addition to testing the LEDs, this also checks the RPG.

5-77 To exit LED test mode, either press OUTPUT ADJUST once to enter self test, or press in OUTPUT ADJUST for a least three seconds to return to normal operation.

## 5-78 Troubleshooting Trees

### WARNING

*Maintenance described herein is performed with power supplied to the instrument, and protective covers removed. Such maintenance should be performed only by service-trained personnel who are aware of the hazards involved (for example, fire and electrical shock). Where maintenance can be performed without power applied, the power should be removed.*

5-79 The troubleshooting trees are the most exhaustive troubleshooting technique available for use with the 6034A. They can be used either with or without having performed self tests. After having determined that the 6034A is malfunctioning, the user should remove the unit from the operating system and proceed to the main troubleshooting tree. The main tree will isolate trouble to a particular circuit and direct the user to further procedures, such as signature analysis or other troubleshooting trees, to isolate the trouble within a circuit.

5-80 The following notes apply to the troubleshooting trees.

1. Most troubleshooting procedures start with the test setup described in paragraph 5-81. The main troubleshooting tree starts with the output terminals open circuited.
2. Before removing or replacing fuses or other components, turn power off and disconnect input power cable.

### WARNING

*Some circuits on the power mesh are connected directly to the ac power line. Exercise extreme caution when working on energized circuits. Energize the supply through an isolation transformer to avoid shorting ac energized circuits through the test instrument's input leads. (The isolation transformer must have a power rating of at least 1 kVA.) During work on energized circuits, the safest practice is to disconnect power, make or change the test connections, and the reapply power.*

*Make certain that the supply's ground terminal (⏏) is securely connected to an earth ground before applying power. Failure to do so will cause a potential shock hazard that could result in personal injury.*

3. Allow input capacitors two minutes to discharge before making resistance checks or removing components in primary circuit.
4. Unless otherwise noted, all voltages on the power mesh and control board assemblies are measured with respect to bias common, available at A2U1 heatsink. Voltages on the HP-IB/microcomputer assembly are measured with respect to either  $\nabla$  or  $\nabla$ 2, which should be shorted together for troubleshooting.  $\nabla$ 1 is available at TP1 and wire loop W17.  $\nabla$ 2 is available at TP2, TP3, and wire loop W18. Voltages on the front-panel assembly are measured with respect to either  $\nabla$ 2 or  $\nabla$ 3, available at wire loops on the front-panel printed circuit board.
5. Numbers in brackets refer to waveforms shown in Figure 5-21.
6. Unless arrows point otherwise, flow of troubleshooting trees is down and to the right.
7. The troubleshooting trees provide general guidelines to help isolate trouble. They will not isolate all possible troubles. The user should use signal tracing and other standard troubleshooting techniques to identify faulty components. The user is responsible for connecting and adjusting meters, oscilloscopes, etc. properly. Before replacing a component, check connections to the component and ensure that bias voltages to the component are correct.
8. Test programs are given for two HP controllers; HP 9825 or 9826 programs are on the left, HP 85 programs are on the right.
9. Table 5-4 provides descriptions of the control board test points. Table 5-5 provides descriptions of the HP-IB/microcomputer test points.
10. After isolating and correcting a problem, go back to the beginning of main troubleshooting tree, Figure 5-16, unless otherwise directed.

**5-81 Troubleshooting Test Setup.** Unless otherwise noted, troubleshooting procedures should start with the following test setup.

1. Turn off 6034A and disconnect all loads.
2. Strap rear-panel terminal block for local sensing, and no connections to A1 and A2, as shown in Figure 3-3.
3. For procedures that call for a load resistor, connect a 200-ohm 10-watt load resistor across output terminals.
4. Turn OVP ADJUST control to maximum (fully clockwise.)
5. Remove top cover.
6. Short together test points TP1 and TP2 or TP1 and TP3 on HP-IB/microcomputer assembly.

## 5-82 Signature Analysis

**5-83** The easiest and most efficient method of troubleshooting microprocessor-based instruments is signature analysis. Signature analysis is similar to signal trac-

ing with an oscilloscope in linear circuits. Part of the microcomputer memory is dedicated to signature analysis, and a known bit stream is generated to stimulate as many nodes as possible within the circuit. However, because it is virtually impossible to analyze a bit stream with an oscilloscope, a signature analyzer is used to compress the bit stream into a four-character signature that is unique for each node. By comparing signatures of the unit under test to the correct signatures for each node, faults can usually be isolated to one or two components. Note that signature analysis provides only go/no-go information; the signature provides absolutely no diagnostic information.

**5-84** Start, stop, and clock signals for the signature analyzer are provided by the unit under test.

**Table 5-4. Control Board Test Point Descriptions**

Test Point Connector P2	Description
1	CV Programming Voltage
2	- Sense
3	I-Monitor Buffer Amplifier Output
4	Overvoltage Status (low = overvoltage)
5	+ Sense
6	Outboard Sense (outboard side of current-monitor resistor)
7	CC Programming Voltage
8	- 12 V Unregulated ( $\approx -25$ V)
9	Constant Voltage Mode (low = CV)
10	Overvoltage Remote Reset Input
11	+ 15 V Unregulated ( $\approx +25$ V)
12	Bias Power Supplies Common
13	Low Bias Voltage or AC dropout (low = low bias or ac dropout)
14	Over Temperature Status (low = over temperature)
15	Constant Current Mode (low = CC)
16	+ 5 V Unregulated ( $\approx +16$ V)
17	Signal to "On" Driver
18	Signal to "Off" Driver
19	(Not used)
20	+ 15 V Regulated
21	+ 5 V Regulated
22	Inboard Sense (inboard side of current-monitor resistor)
23	20 kHz Clock Signal
24	- 12 V Regulated
25	(Not used)
26	I <sub>p</sub> (Primary Current) Ramp Voltage



**Table 5-5. HP-IB/Microcomputer Test Point Descriptions**

Test Point	Description
1	1
2, 3	2
4	$\phi_3$ , $\mu$ processor clock phase 3, used for signature analysis clock
5, 6	A0, start/stop signal
7	CRUCLK, clock signal
8	$\overline{\text{ROM 1}}$ , start/stop signal
9	$\overline{\text{ROM 2}}$
10	$\overline{\text{ROM 3}}$
11	Signature analysis interrupt input, factory use only
12	$\overline{\text{ROM 4}}$
13	Signature analysis clock, used to check ROM data
14, 15	CV DAC LSB, start/stop signal
16	2, connected to TP11 for factory test
17	$\overline{\text{SRQ}}$

5-85 Signature analysis in the 6034A is accomplished in two modes, free-run mode and signature analysis test mode. Free-run mode is used to check the operation of the microcomputer kernel, consisting of the microprocessor, RAM, ROM, and clock. Once proper operation of the kernel has been verified, then the kernel can be used to stimulate the rest of the circuit.

5-86 Instructions in the troubleshooting trees direct the user to specific signature analysis figures. Each figure includes a setup for the signature analyzer front-panel controls and pod connections. (The user should refer to the signature analyzer instruction manual for complete instructions on use of the signature analyzer.)

5-87 If a fault appears to be in the kernel of the microcomputer, signatures are taken with the unit operating in free-run mode. Symptoms of this type of failure include failure of RAM or ROM self test or all front-panel LEDs remaining lit. To operate the 6034A in free-run mode, the free-run jumper pack must be moved from its normal location to the free-run mode location, see Figure 5-11. The jumper pack breaks the DIO lines and provides a NOP code to the microprocessor, which then steps through all of its addresses. Note that it is not necessary to switch the 6034A to signature analysis to take signatures in free-run mode.

5-88 Figure 7-1 shows the location of the two sockets into which the free-run mode jumper pack can be inserted. Normally, the jumper pack is installed in the single 16-pin socket, shorting pins 1 through 8 to pins 9 through 16. For free-run mode the jumper pack is installed between the 8-pin socket and pins 1 through 8 of the 16-pin socket.

5-89 Figure 5-12 shows the signatures that should be found in free-run mode. To operate the 6034A in free-run mode for signature analysis of the microcomputer kernel, proceed as follows.

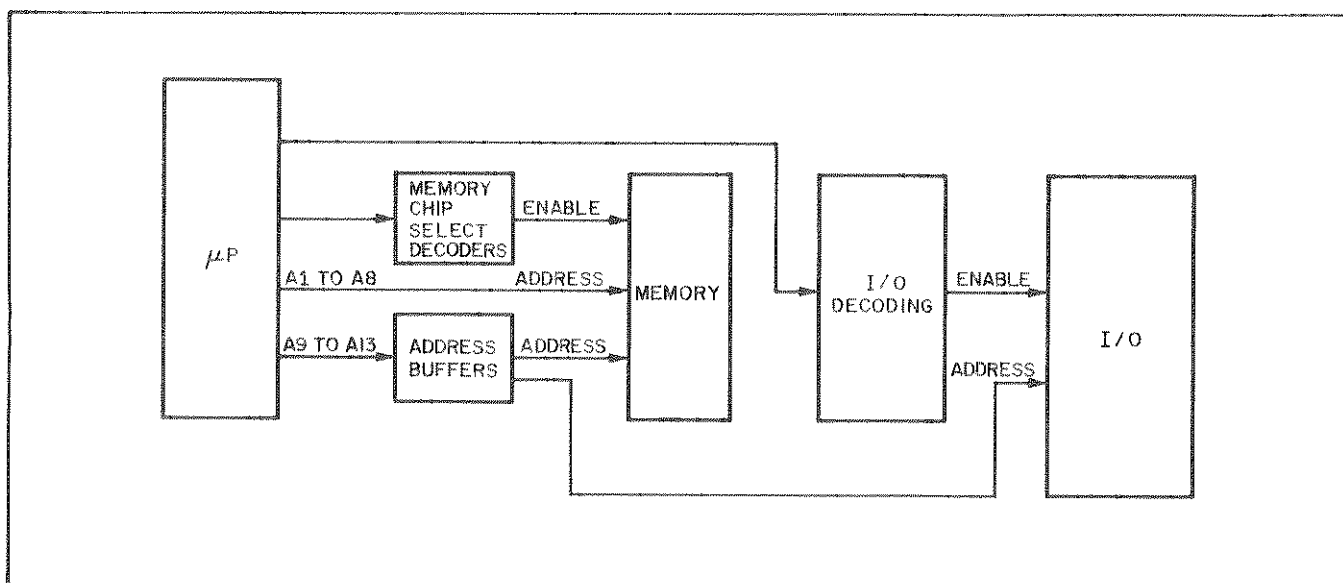

Figure 5-10. Signature Analysis Map

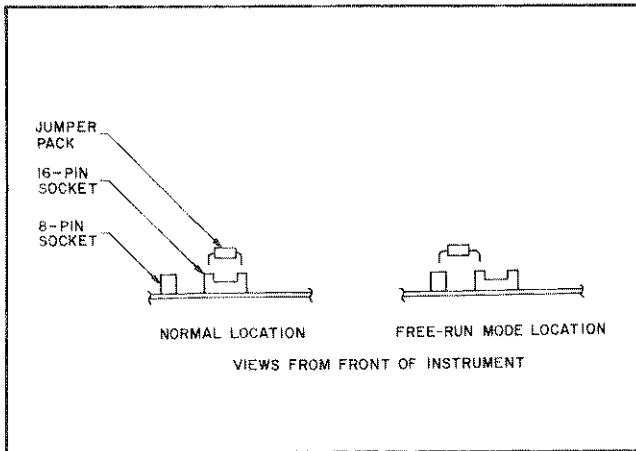

Figure 5-11. Free-Run Mode Jumper

5-90 Turn off the 6034A. Use an I.C. removal tool, or, using a small-blade screwdriver, first pry up one end and then the other end of the jumper pack a little at a time. Be careful not to bend the pins. Be especially careful that all pins are properly located in the socket before pressing the jumper pack down in place.

5-91 The following notes apply to signature analysis of the 6034A.

1. Figure 5-10 shows the circuit functions that are checked using signature analysis, with arrows directing the user from one functional area to another. Figures 5-12 and 5-15 are arranged similar to Figure 5-10 and are subdivided by circuit function.
2. Four-character signatures are written outside the I.C. next to their associated pin. A blank pin indicates that no valid signature exists at that pin for that mode and setup.
3. If a signature is boxed (e.g. 788H) it is an input to that I.C. Unboxed signatures are outputs.
4. A signal's source (for an input) or destination (for an output) is written next to the pin number inside the I.C. outline. This allows the user to trace the signal to determine which component introduces an error.
5. Be certain to use the correct setup as given in each figure.
6. Most signatures are taken on the HP-IB/microcomputer assembly. Front-panel I.C.s are labeled.
7. Note the signatures for Vcc and ground on the I.C. being examined. If an incorrect signature is the same as that of Vcc or ground, that point is probably shorted to Vcc or ground.
8. If two pins have identical signatures, they are probably shorted together. If two signatures are similar, it is only coincidence. For example, if the signature at a certain point should be 65C4, a signature of 65C3 is not "almost right." **No diagnostic information can be inferred from an incorrect signature.**
9. If a signature is incorrect at an input pin, but is correct at its source (output of previous I.C.), check for printed circuit and soldering discontinuity.
10. An incorrect signature at an output could be caused by a faulty component producing that output; or, a

short circuit in another component or on the board could be loading down that node. A current probe can be used to determine which component is drawing excess current from a node.

11. If many signatures are wrong, including signatures for +5 V, the fault is probably in signals used to clock or gate the signature analyzer. Check that the A0, A13/CRUOUT,  $\emptyset$ 3, and CRUCLK signals are clean square waves.
12. Do not begin troubleshooting with signature analysis. Start with the main troubleshooting tree.

5-92 **Free-Run Mode Procedure.** The following paragraphs outline a basic course of action for troubleshooting in free-run mode.

5-93 Set the free-run jumper pack in the free-run mode position, and set the signature analyzer controls as shown on Figure 5-12. Start taking signatures at the microprocessor. If all microprocessor signatures are correct, check the memory chip select decoders and then the memory devices. If all inputs to a component are good but the output is wrong, that component is probably bad. Check also for a short on the printed-circuit board or other components that might be loading that node.

5-94 If all the above signatures are correct, the fault could be the ROM data. Check the signature at TP13, the signature analysis clock generator (see Figure 5-13). If the signature is incorrect, troubleshoot the signature analyzer clock generator circuit. If the TP13 signature is correct, check the ROM data using Figure 5-14. Note that the signature analyzer test setup is different for checking ROM. RAM cannot be checked at this point, because nothing has been stored there. However, if all signatures so far have been correct, and the RAM self test failed, the RAM is probably faulty.

5-95 Remember to replace the free-run jumper pack after troubleshooting the microcomputer kernel.

5-96 **Signature Analysis Procedure.** Figure 5-15 is used for signature analysis when the microprocessor has passed turn-on self test. Most faults for which this mode is appropriate involve I/O communication.

5-97 Ensure that the free-run jumper pack is in its normal position, and switch the 6034A to signature analysis test mode (CURRENT LED flashing). Set the signature analyzer controls as shown in Figure 5-15. If an input or output port is being checked, start at that port and work back toward the microprocessor. Remember that the numbers next to each pin number give the location to which that pin is connected.

5-98 For example, assume that OVP will not reset, but the OVP circuit appears to function properly. To troubleshoot this problem, proceed as follows.

- a. Using the schematic and labels on Figure 5-15, locate the output port that resets OVP; A3U14, pin 6, on the front-panel assembly.
- b. Check the signature at A3U14-6. Because this is an output port, if the signature is correct the fault is probably in the OVP circuit. Use standard troubleshooting techniques.

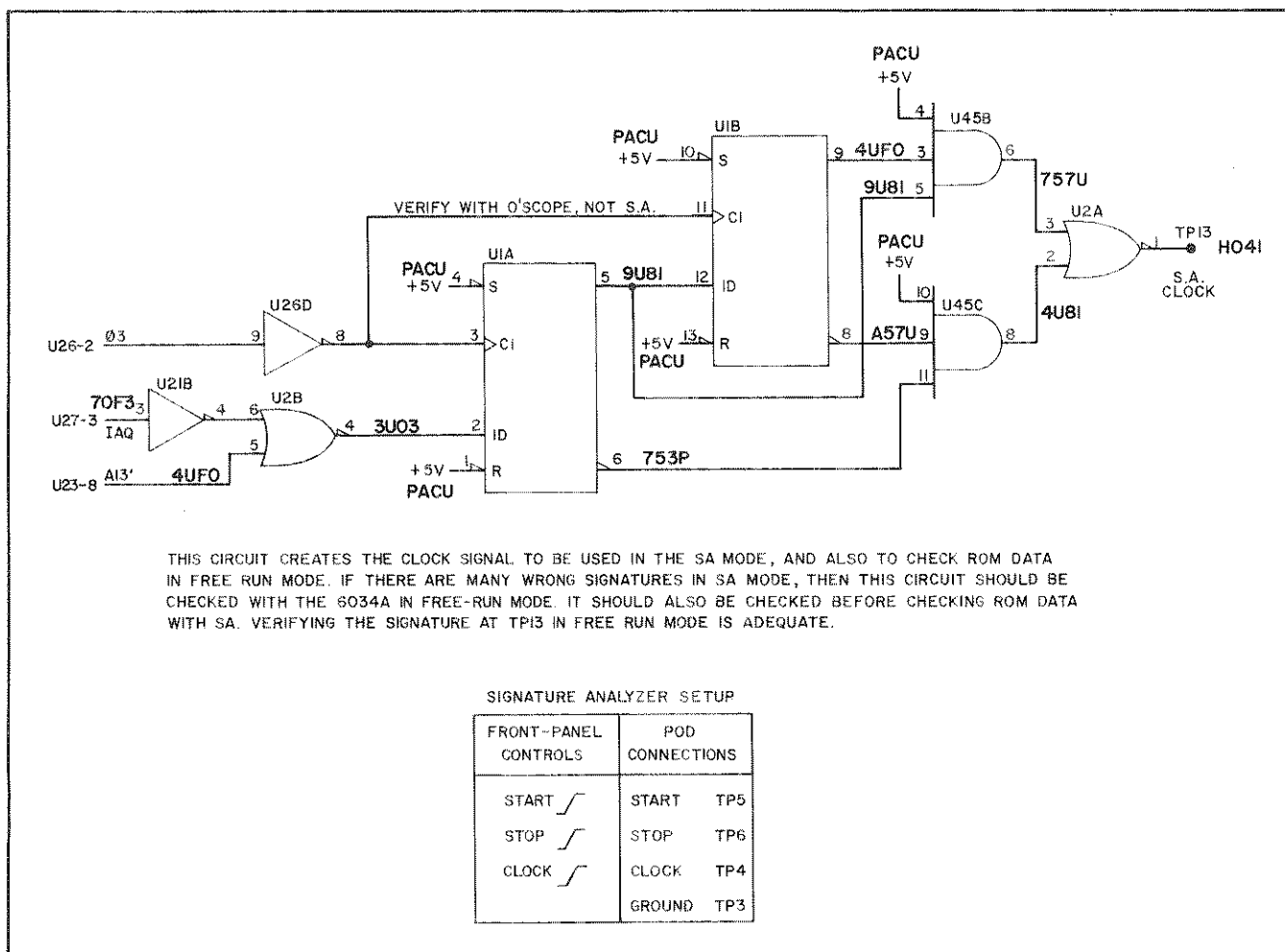

Figure 5-13. Signature Analysis Clock Generator Troubleshooting

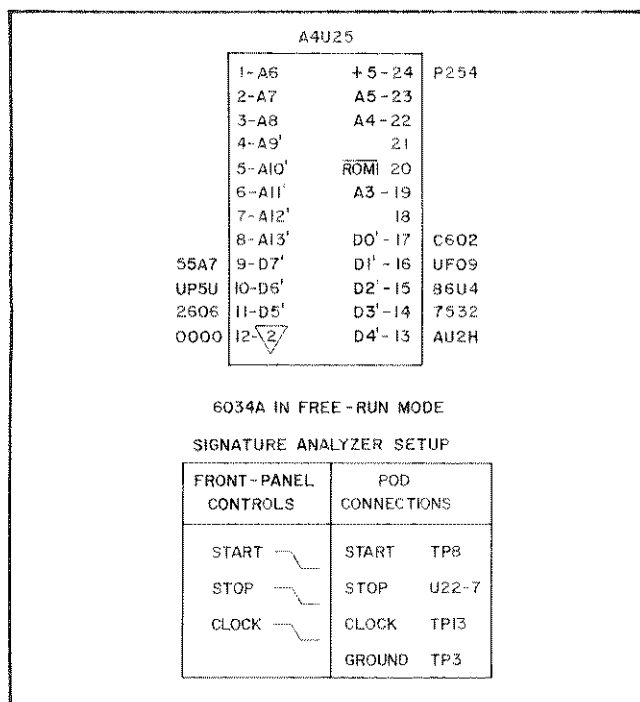

Figure 5-14. ROM Data Test

- If the A3U14-6 signature is incorrect, check inputs to A3U14 (A10', A11', A12', CRUOUT'). If they are correct, A3U14 is probably bad.
- If any of the A3U14 input signatures are incorrect, check the signature at the location written next to the bad pin. For example, if the signature of A10' at A3U14-3 is incorrect, check A4U13-3 on the HP-IB/microcomputer assembly.
- Continue until you locate the faulty component or reach the microprocessor. However, if the microprocessor has passed earlier tests, recheck your setups and procedure very carefully before replacing the microprocessor.

**5-99 Input and Output Ports.** For input ports and some output ports, signature analysis is not appropriate. The microprocessor cannot stimulate its own inputs, and most LEDs are not being addressed during signature analysis mode. The SELF TEST LED should be on (its output port, A3U11-11, should be at ground), and the CURRENT LED should be flashing. All other LEDs should be off, with their output ports at +5 volts.

To check input ports:

- Verify that the input to the port is correct.

- b. Use signature analysis to verify that the input port is being addressed and enabled.
- c. If both the above are correct, the input port I.C. is probably bad.

To check output ports:

- a. Switch unit to LED test mode.
- b. Check the output port of any malfunctioning LED with a logic probe (the signature analyzer probe also operates as a logic probe).
- c. The output port should be low (ground) when the LED should be on, and high (+5 volts) when the LED should be off.
- d. If the logic levels are correct, check the LED.
- e. If the logic levels are incorrect, use signature analysis to verify that the output port is being addressed and enabled.

- f. If more than one LED on a given I.C. does not light, either the I.C. or its enable input is probably bad.

5-100 After troubleshooting be certain to restore to normal operating condition any of the following that may have been changed.







1. Sensing and other rear-panel connections.
2. TP1 to TP2 or TP3 on HP-IB/microcomputer assembly (grounds  and ).
3. TP11 to TP14 on HP-IB/microcomputer assembly (signature analysis interrupt).
4. Signature analysis free-run jumper pack.
5. Bias power supply jumpers J2 (5 jumpers) and J5 (3 jumpers) on HP-IB/microcomputer assembly.

Table 5-6. HP-IB/Microcomputer Bias Supply Voltages

Unregulated*				Regulated (±5%)		
Nominal	Test Point	Minimum Valley	Maximum Peak	Test Point	Current	Jumpers
<b>HP-IB BIAS VOLTAGES</b>						
+ 5	A5-W/YEL	11.4 V	18.0 V	A5-W/BLU	0.75 A	A4J5
+ 12	A4F1	17.5 V	27.0 V	A4C63	60 mA	
PON 1, Measured at A4R65 - Normally 0 V						
 TP1						
<b>MICROCOMPUTER BIAS VOLTAGES</b>						
+ 5	A5-W/ORN	11.4 V	19.0 V	A5-W/RED	1 A	A4J2
+ 12	A4CR7Cath	17.5 V	27.0 V	A4C35 +	60 mA	
+ 15	A4CR7Cath	17.5 V	27.0 V	A4C32 +	60 mA	
- 15	A4CR6 Ano	- 17.5 V	- 27.0 V	A4C33 -	60 mA	
PON2, Measured at A4R75 Normally 0 V						
 TP2 and TP3						
*Observe unregulated voltages with an oscilloscope.						
HP-IB common (  ) is isolated from microcomputer and power mesh/control board common (  ). A potential across A4R65 (PON 1) or A4R75 (PON 2) indicates low bias voltages. A problem with unregulated voltages on either side of isolation will cause the PON signal on both sides to go low. The two PON signals communicate with each other through photo-isolators A4U88 and A4U89. These signals protect the 6034A from trying to operate with low bias voltages.						
The blue A4J2 and A4J5 jumpers should be removed to disconnect the bias voltages while troubleshooting the HP-IB or microcomputer bias supplies. In this way the user can determine if the bias voltages are being pulled down by a short circuit. To ensure that the bias supplies can operate under load, use the current values listed to select a resistor of the proper value to simulate full load. Connect the load resistor to the bias supply output with the output jumper removed to check that the bias voltage remains within regulation under load.						
Remember to reconnect the J2 and J5 jumpers after correct operation of the bias supplies has been verified.						

**Table 5-7. Power Mesh/Control Board Bias Voltages**

(All bias voltages measured at Control Board test fingers (A2P2) with respect to bias common <sup>2</sup> at pin 12 or at A2U1 heatsink. Table 5-8 lists semiconductor components operating on each bias supply.)

Bias Voltage	Measurement Point	Normal Range	Check these Components
+5 V Reg	Pin 21	+4.75 V to +5.25 V	Check for presence of +5 V Unreg (+12 to +19 V, pin 16). If absent, check A1T5 pins 7 and 9, A1CR22-23, A1C35, A1R61, A1VR5. If present, check A2U1.
+15 V Reg	Pin 20	+14.10 V to 15.90 V	Check for presence of +15 V Unreg (+19 V to +31 V, pin 11). If absent, check A1T5 pins 6 and 10, A1U3, A1C36. If present, check A2Q1, A2U2, A2R2-R7, A2VR1, A2C3.
-12 V Reg	Pin 24	-12.96 V to -11.4 V	Check for presence of -12 V Unreg (-19 V to -31 V, pin 8). If absent, check A1C37. If present check A2Q2, A2U3, A2R8-R11, A2C4.

**Table 5-8. Semiconductor Components Operating on Each Power Mesh Bias Supply**

+5 V REG	+15 V REG	-12 V REG
A1U2 A2Q4 A2Q6 A2Q7 A2Q8 A2Q9 A2Q14 A2U4 A2U5 A2U6 A2U7 A2U8 A2U9 A2U10 A2U12	A1Q8 (+6.5 V) A1U1(+14.5 V) A2Q12 A2Q13 A2U11 A2U13 A2U14	A2U11 A2U12 A2U13 A2U14
	+15 V UNREG A2U2	-12 V UNREG A2U3
	+5 V UNREG A1Q11 A2Q5 A2U1	-8 V UNREG A1Q6 A1U5

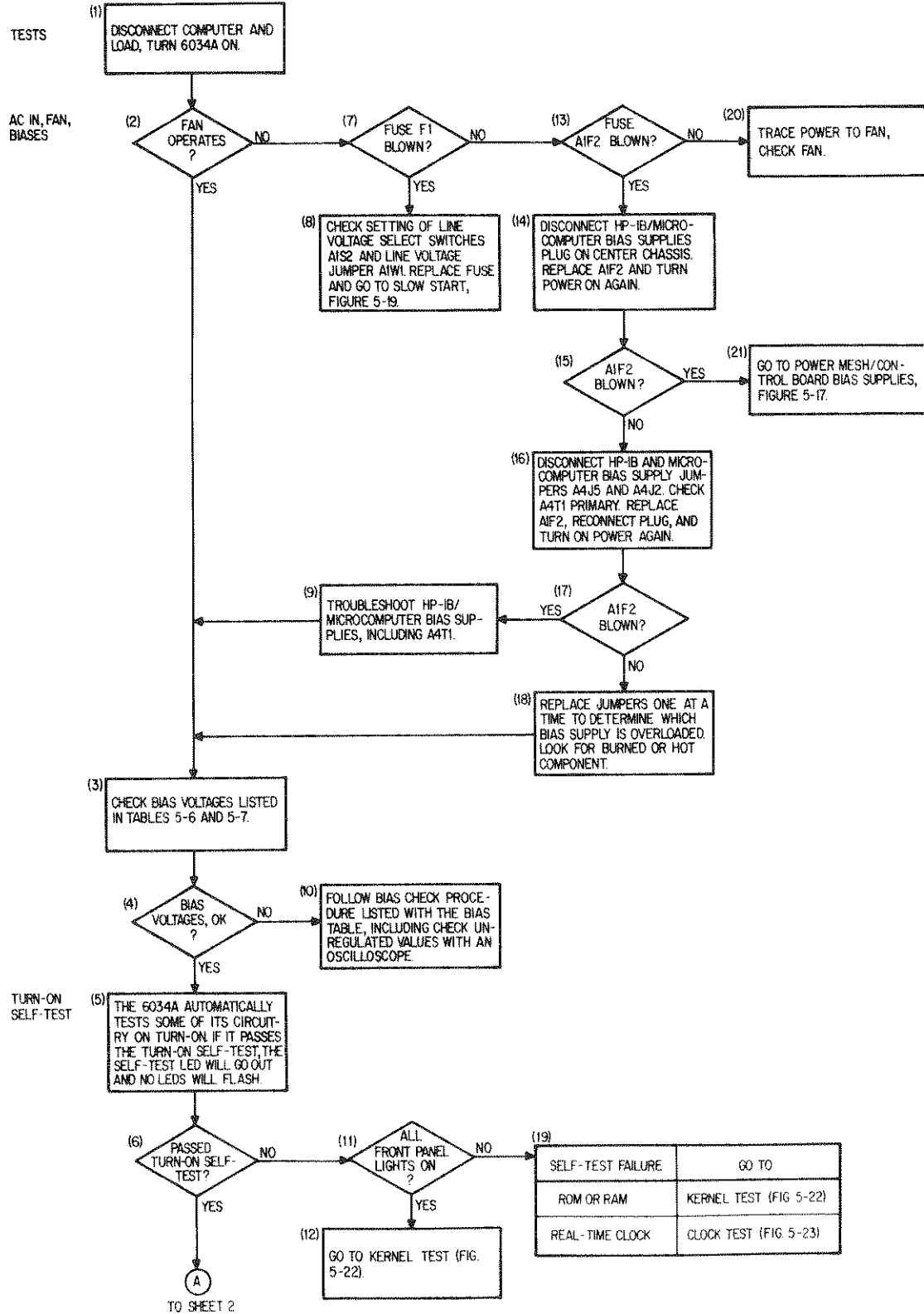

Figure 5-16. Main Troubleshooting Tree (Sheet 1 of 8)

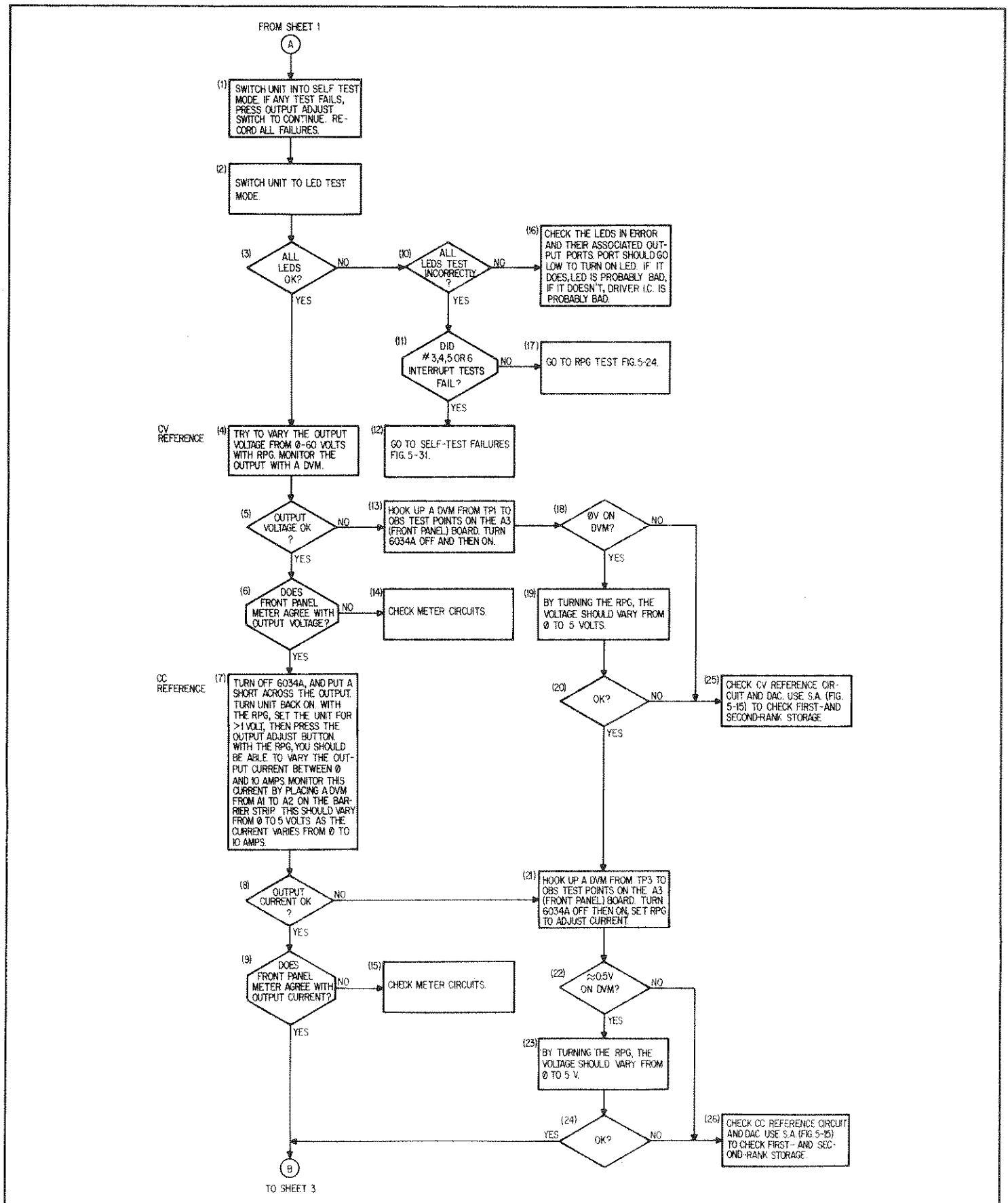

Figure 5-16. Main Troubleshooting Tree (Sheet 2 of 8)

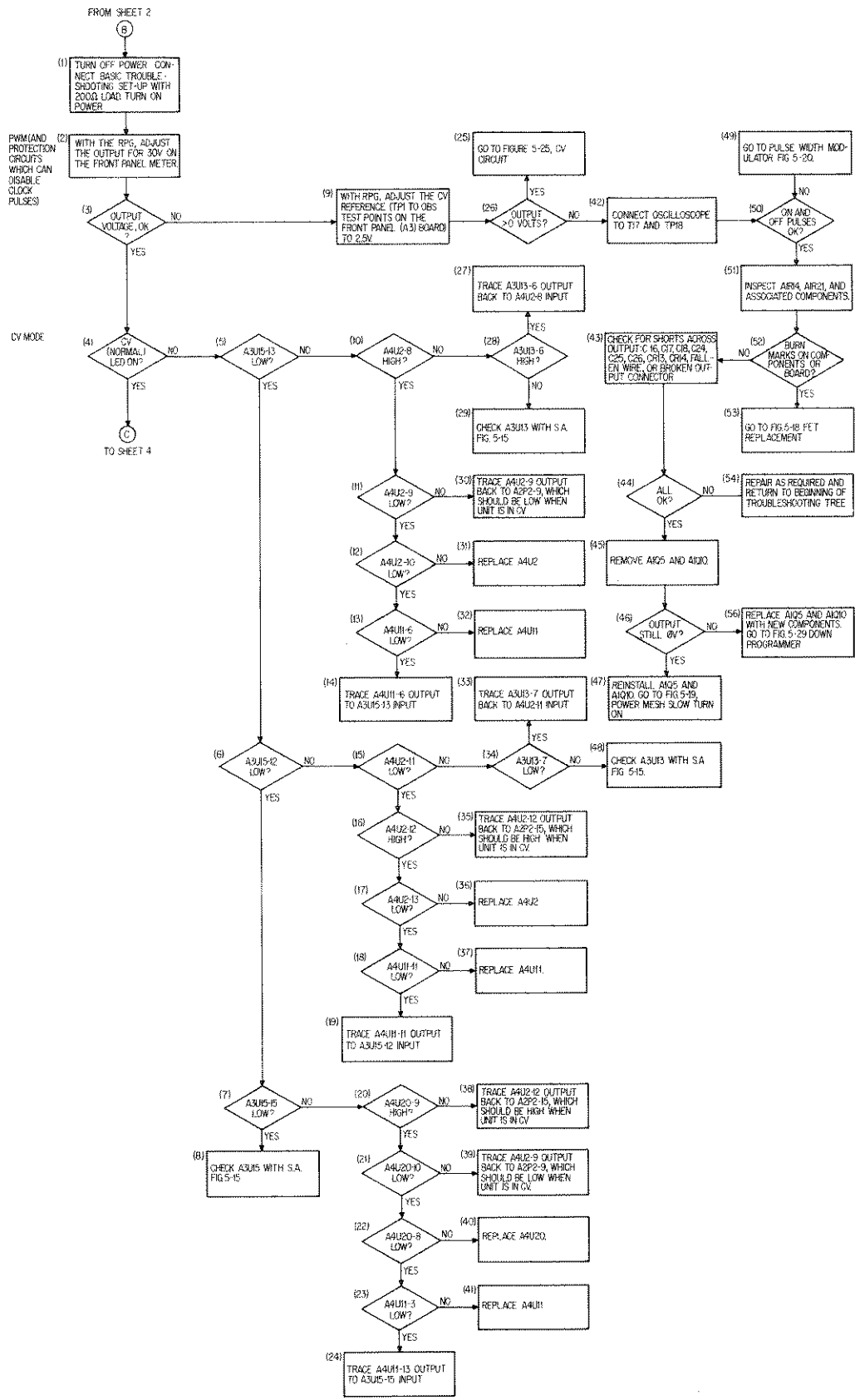

Figure 5-16. Main Troubleshooting Tree (Sheet 3 of 8)



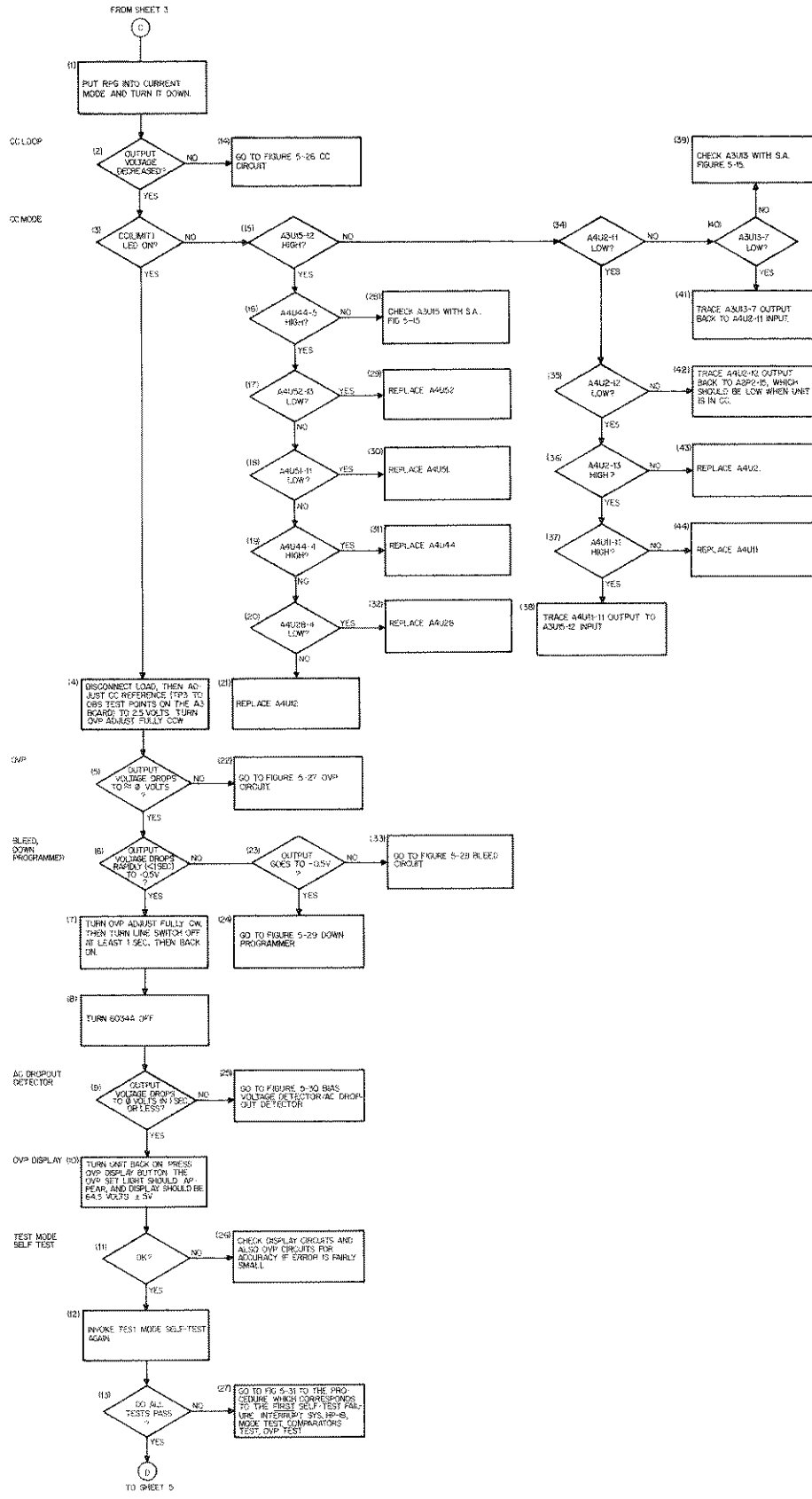

Figure 5-16. Main Troubleshooting Tree (Sheet 4 of 8)

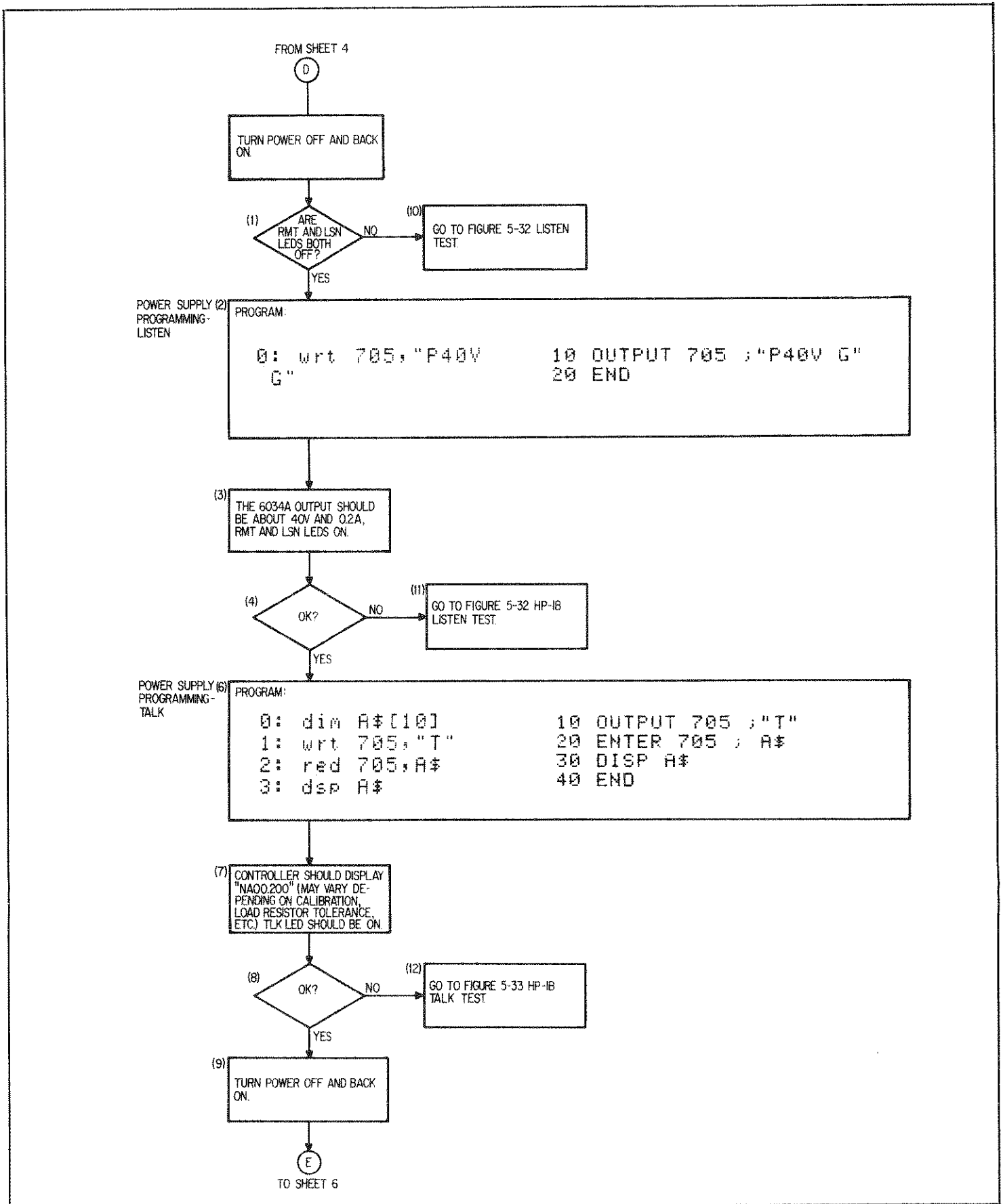

Figure 5-16. Main Troubleshooting Tree (Sheet 5 of 8)

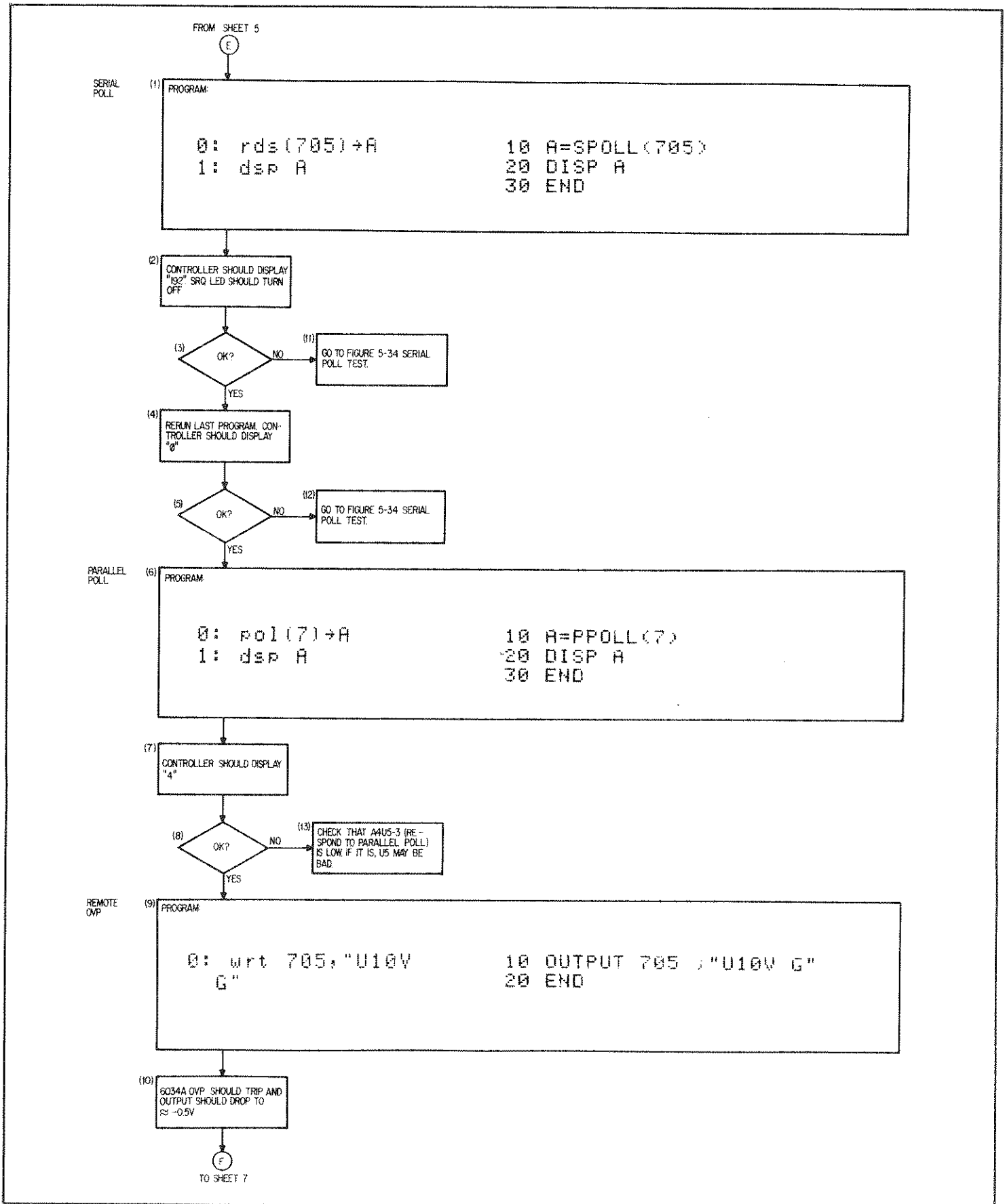

Figure 5-16. Main Troubleshooting Tree (Sheet 6 of 8)

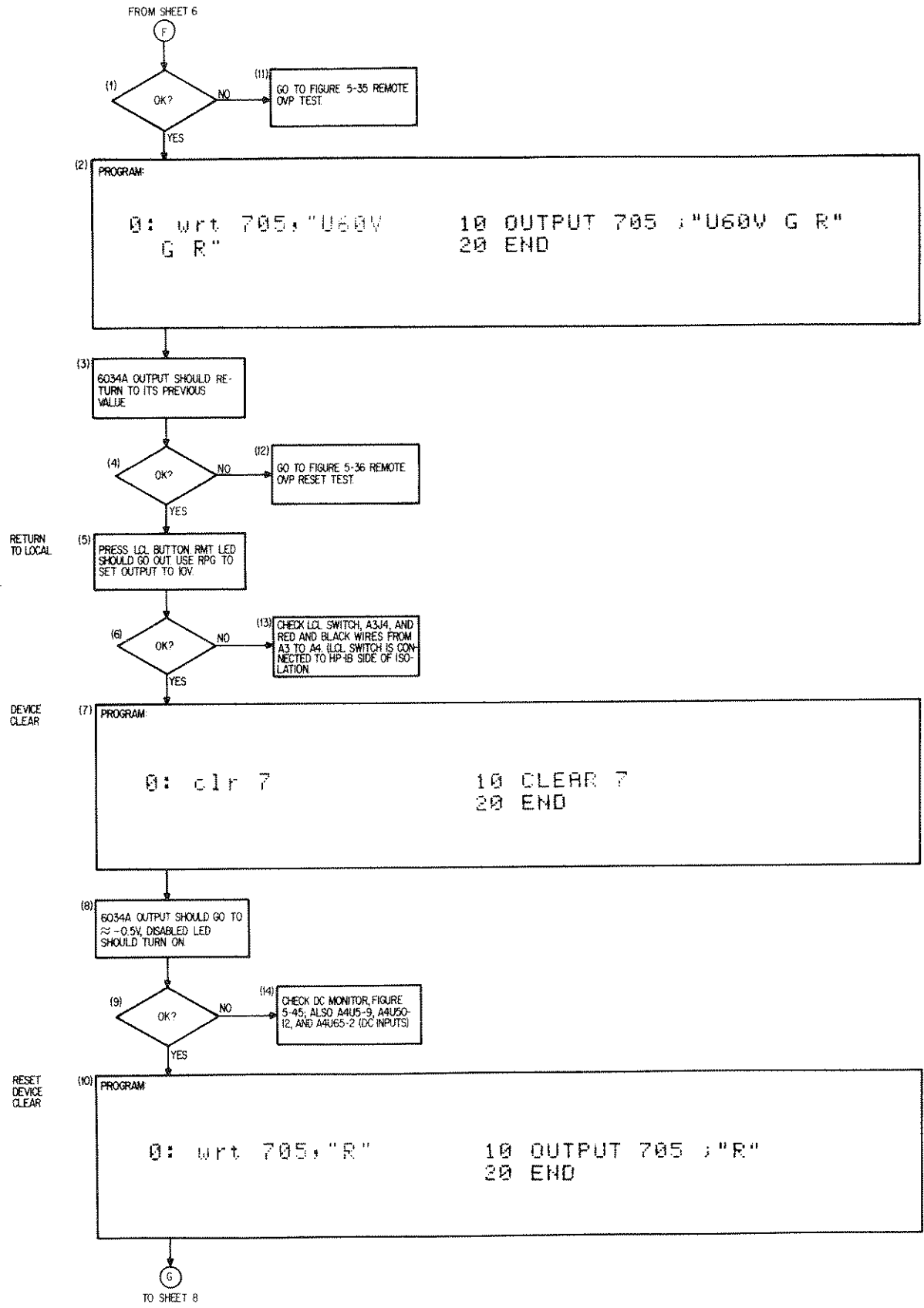

Figure 5-16. Main Troubleshooting Tree (Sheet 7 of 8)

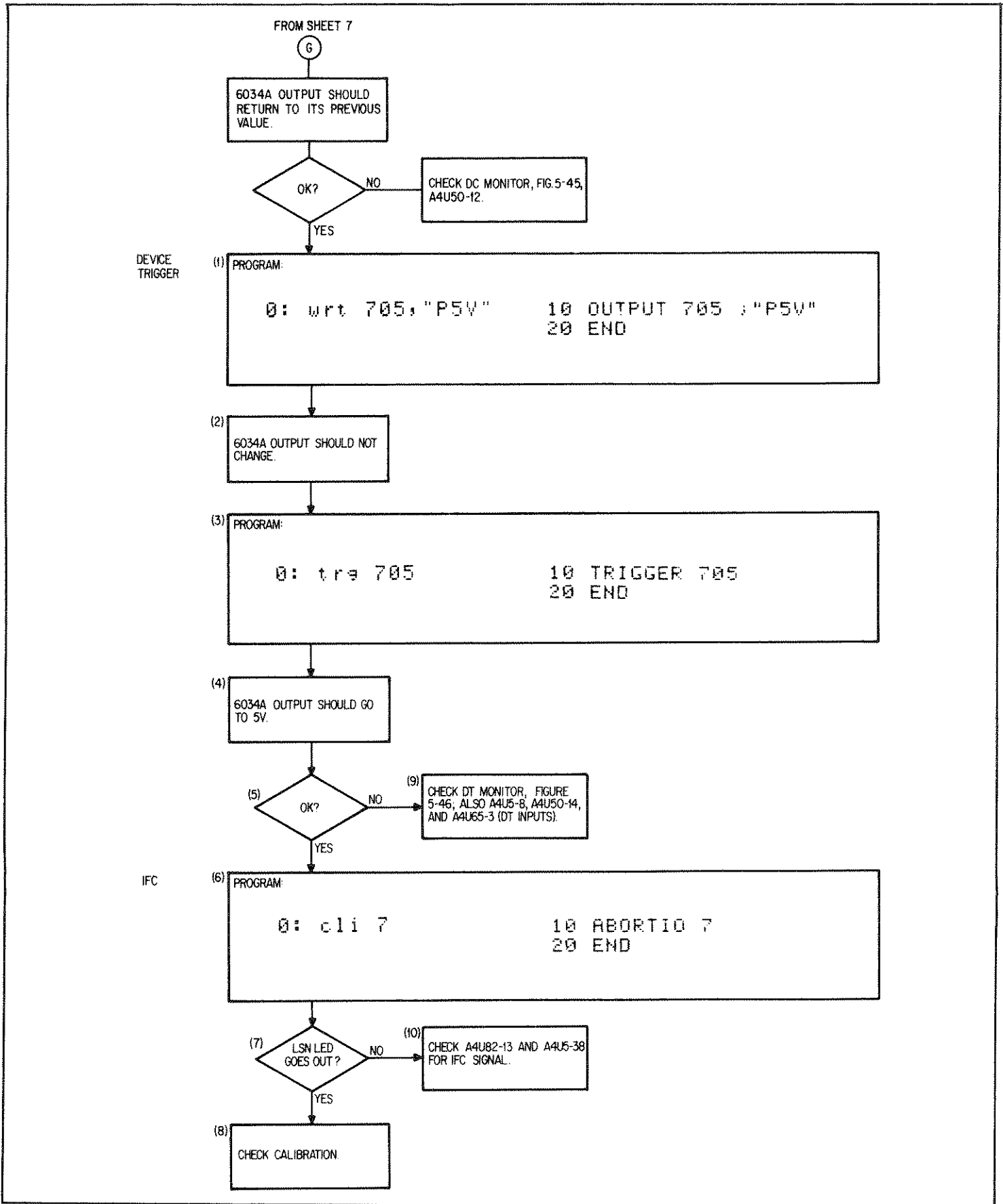

Figure 5-16. Main Troubleshooting Tree (Sheet 8 of 8)

NOTE:

1. TABLE 5-8 LISTS THE ACTIVE COMPONENTS OPERATING ON EACH POWER MESH/CONTROL BOARD BIAS SUPPLY.

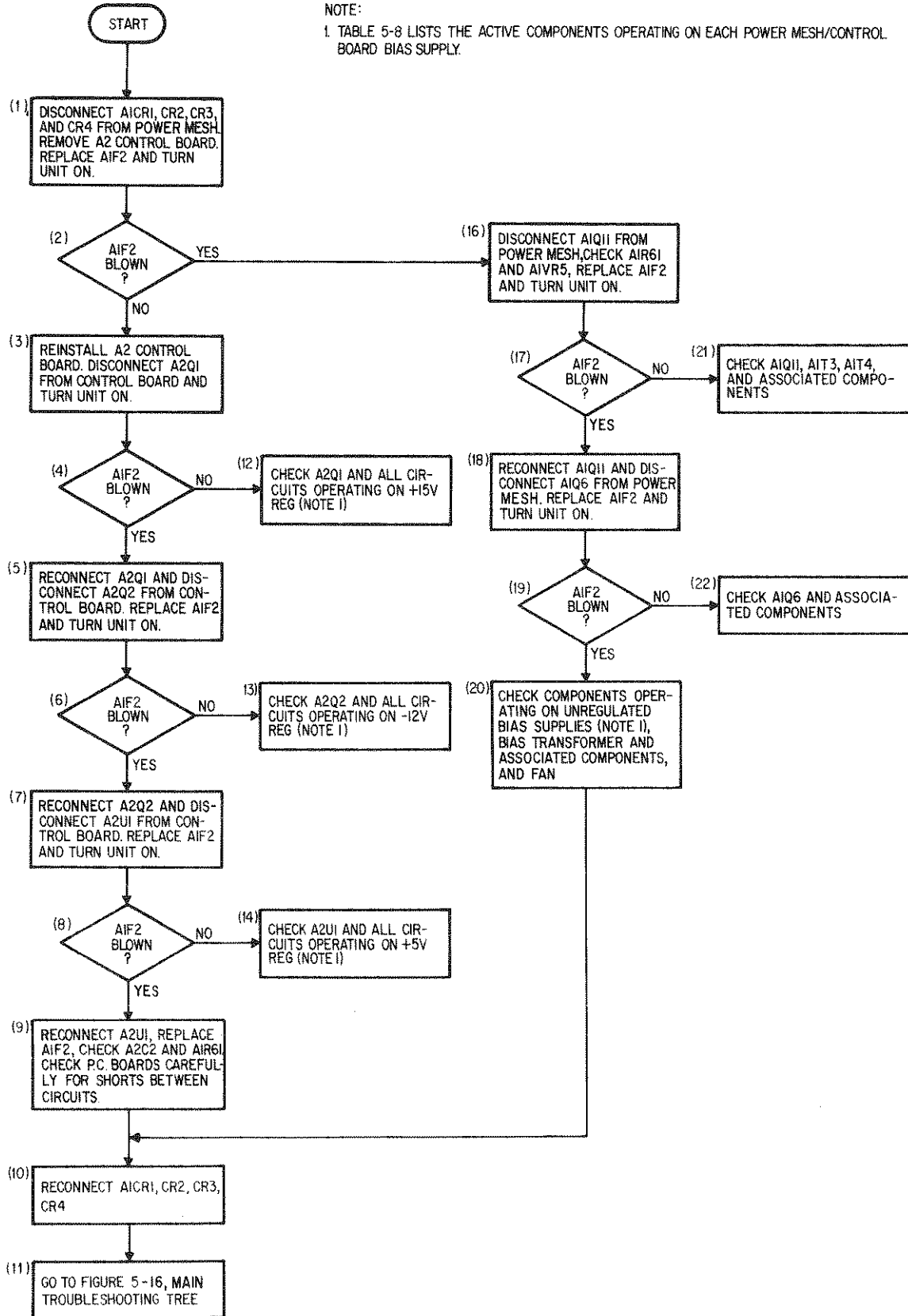

Figure 5-17. Power Mesh/Control Board Bias Supplies Troubleshooting

In case of damage to FETs or driver circuits, replace both FETs and all other components provided in FET Service Kit, HP Part No. 5080-1953.

Note:

1. Handle FETs with care when out of circuit. Use a grounding strap to avoid static discharge into gate. Avoid touching the gate or source pins. Do not clip the leads too short when replacing FETs; they make good test points. Be certain to replace all washers, spacers, etc. Use a small amount of heat sink compound on both sides of mica insulator when replacing FETs. Do not use any heat sink compound containing silicone. An organic zinc oxide cream, such as American Oil and Supply Company Heat Sink Compound #100, is recommended.

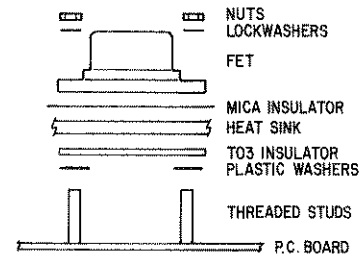
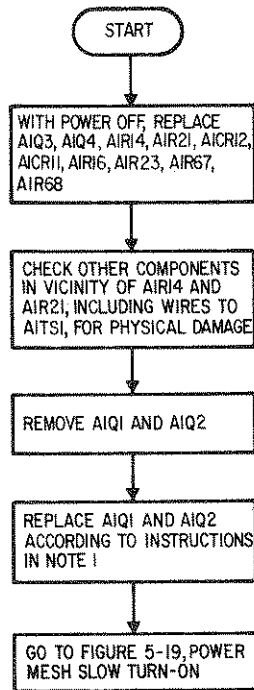

Figure 5-18. FET Replacement

Notes:

1. See Table 5-1 for recommended model.
2. Use a dc power supply variable from 0 to at least 40 volts, with current limit set between 0.5 A and 2 A. The easiest place to connect the external supply is to the two thermistors, RT1 and RT2, on the power mesh. Make connection to the posts to which thermistors are soldered; do not make connections directly to the thermistor leads. Connect the + output of the external supply to either post of RT1 (close to side of unit). Connect the - output of the external supply to either post of RT2 (closer to center of unit).
3. AC input voltage at which Level Detector trips;
  - ≈ 70 V for nominal 100 VAC
  - ≈ 154 V for nominal 220 VAC
  - ≈ 84 V for nominal 120 VAC
  - ≈ 168 V for nominal 240 VAC

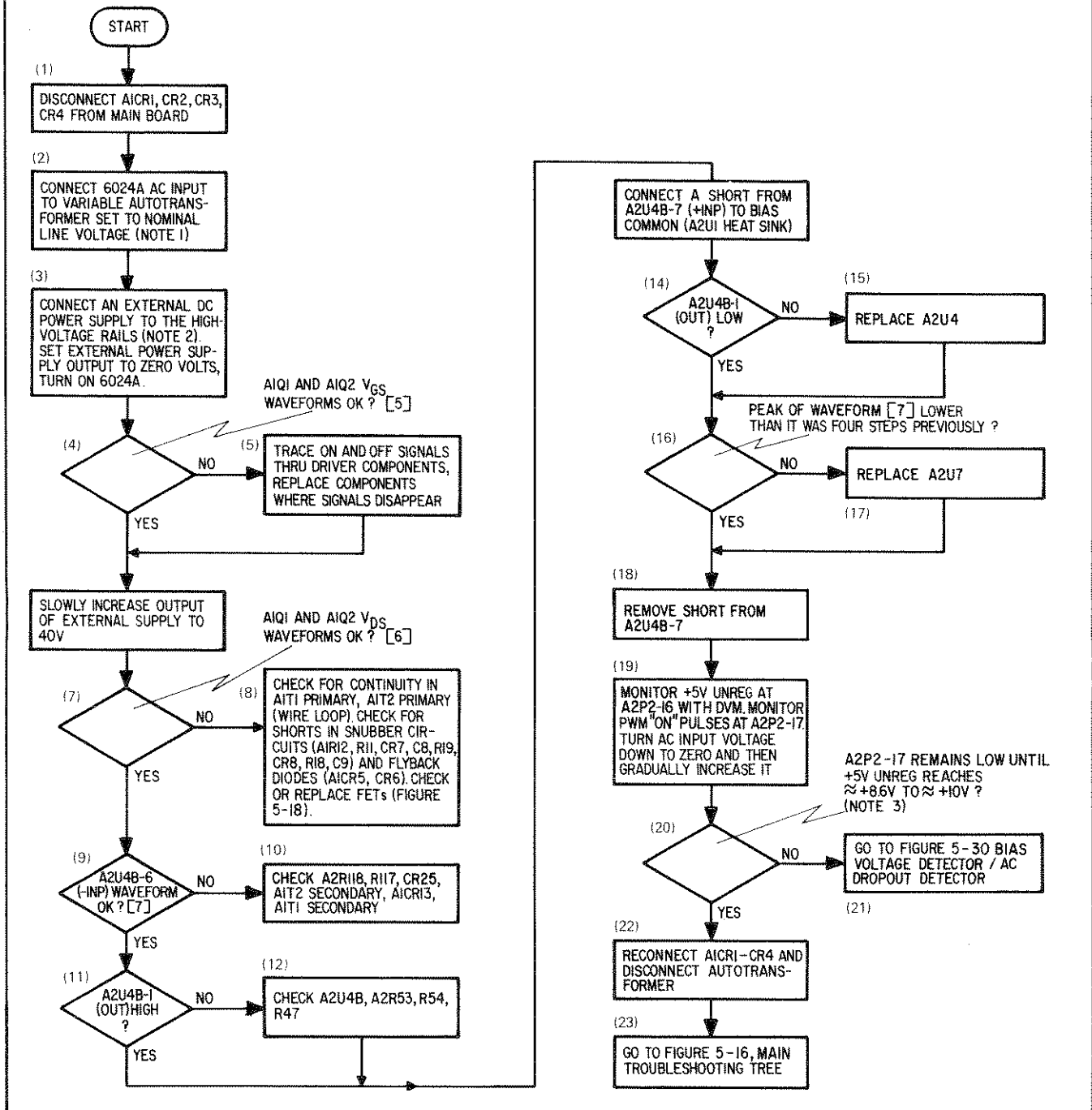

Figure 5-19. Power Mesh Slow Turn On



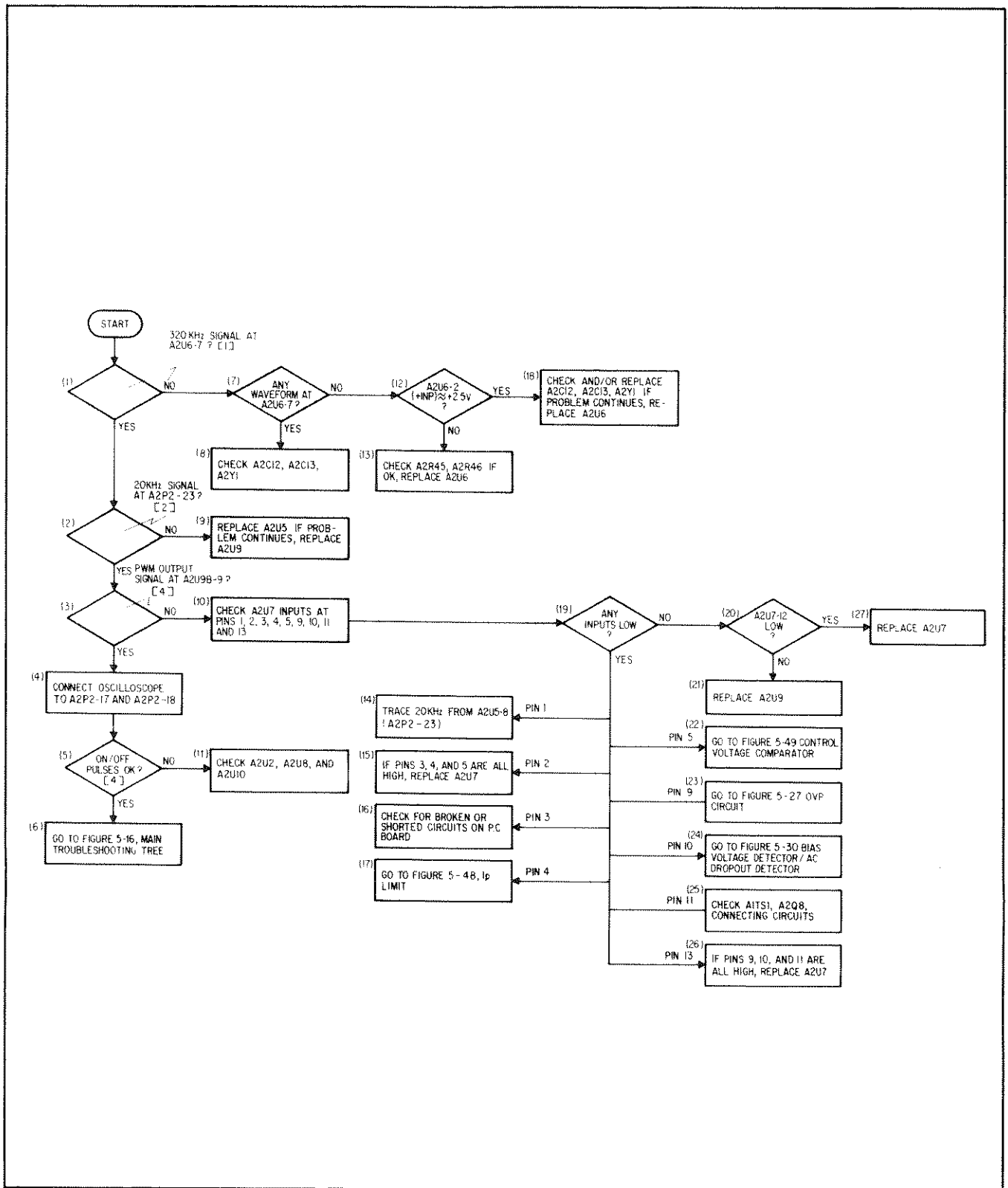
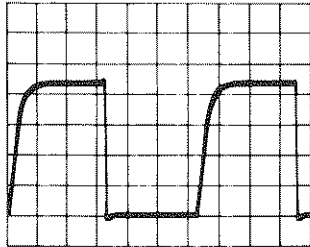

Figure 5-20. Pulse Width Modulator

NOTE: Waveforms taken with 200-ohm 10-watt resistor connected across output terminals, output voltage and current set to midrange, and OVP ADJUST set to maximum (fully CW). Except for waveforms 5 and 6, oscilloscope probe is grounded at A2U1 heat sink. Waveforms 5, 6, and 7 are taken with reduced voltage on 6034A input rails (see Figure 5-19, note 2).

### CAUTION

*Turn power off while connecting or disconnecting test equipment from 6034A.*



[1]  
A2U6-7  
320kHz CLOCK  
0.5 $\mu$ S/DIVISION  
1V/DIVISION

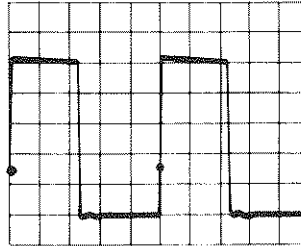

[5]  
A1Q1 VGS  
A1Q2 VGS  
10 $\mu$ S/DIVISION  
5V/DIVISION

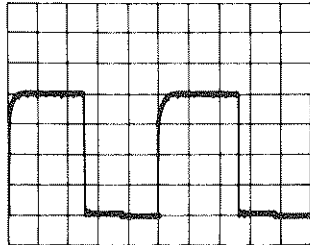

[2]  
T.P. 23  
20kHz CLOCK  
10 $\mu$ S/DIVISION  
1V/DIVISION

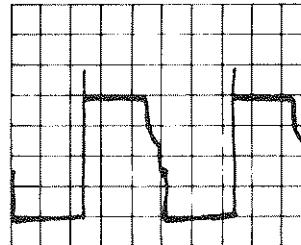

[6]  
A1Q1 VDS  
A1Q2 VDS  
10 $\mu$ S/DIVISION  
10V/DIVISION

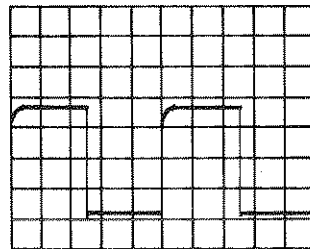

[3]  
A2U9-9  
PWM OUTPUT  
10 $\mu$ S/DIVISION  
1V/DIVISION

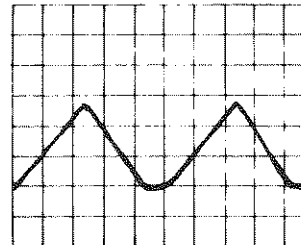

[7]  
A2U4B-6  
I<sub>p</sub> SENSE  
10 $\mu$ S/DIVISION  
0.05V/DIVISION

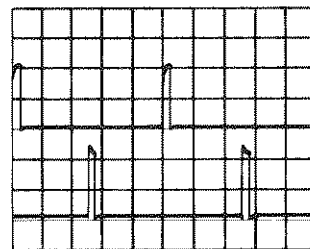

[4]  
T.P. 17  
ON PULSE  
10 $\mu$ S/DIVISION  
2V/DIVISION  
  
T.P. 18  
OFF PULSE  
10 $\mu$ S/DIVISION  
2V/DIVISION

Figure 5-21. Power Mesh/Control Board Waveforms

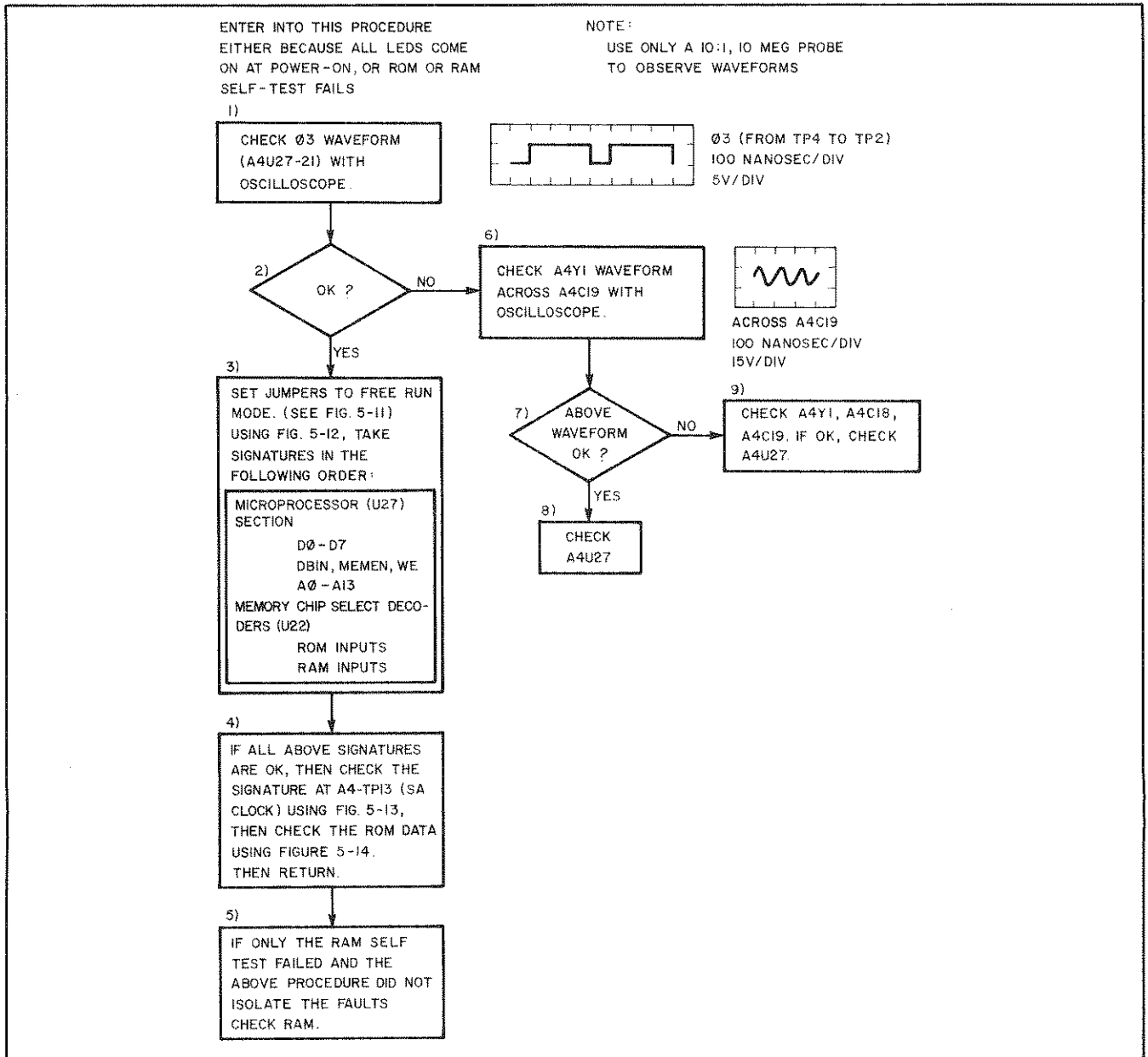

Figure 5-22. Kernel Test

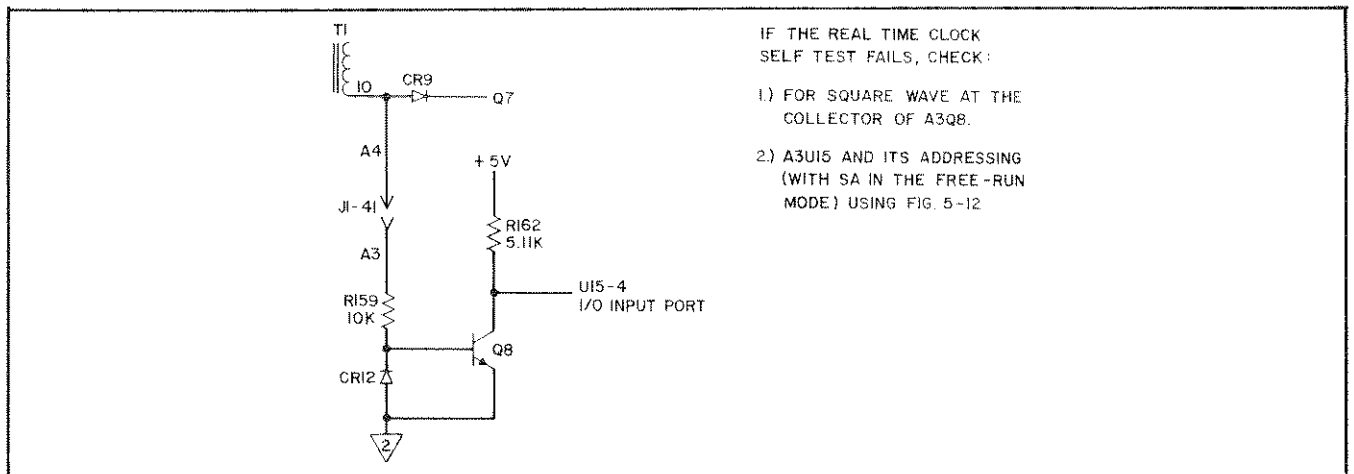

Figure 5-23. Clock Test

ALL POINTS TESTED ARE  
ON FRONT - PANEL ASS'Y A3.

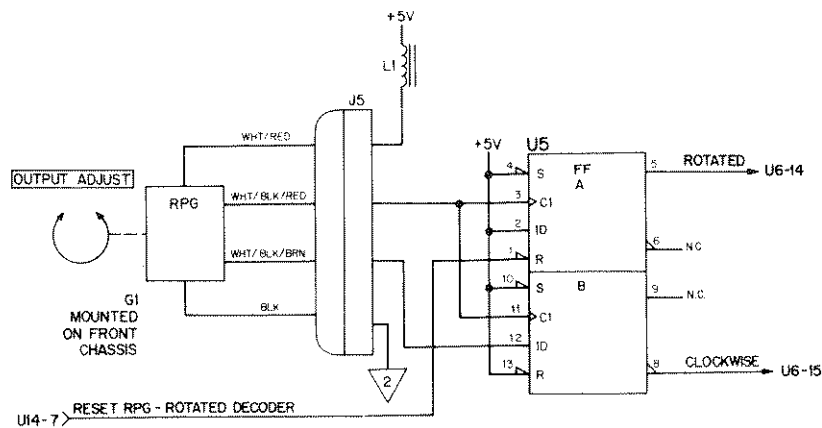
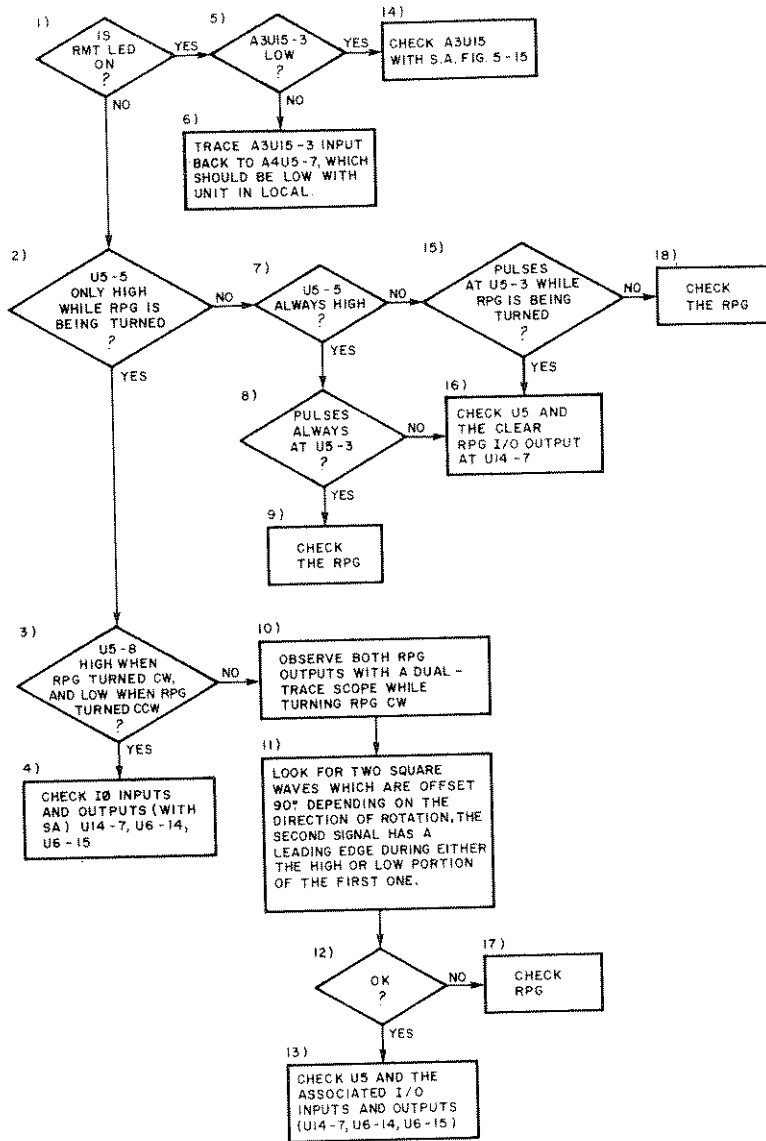

Figure 5-24. RPG Test

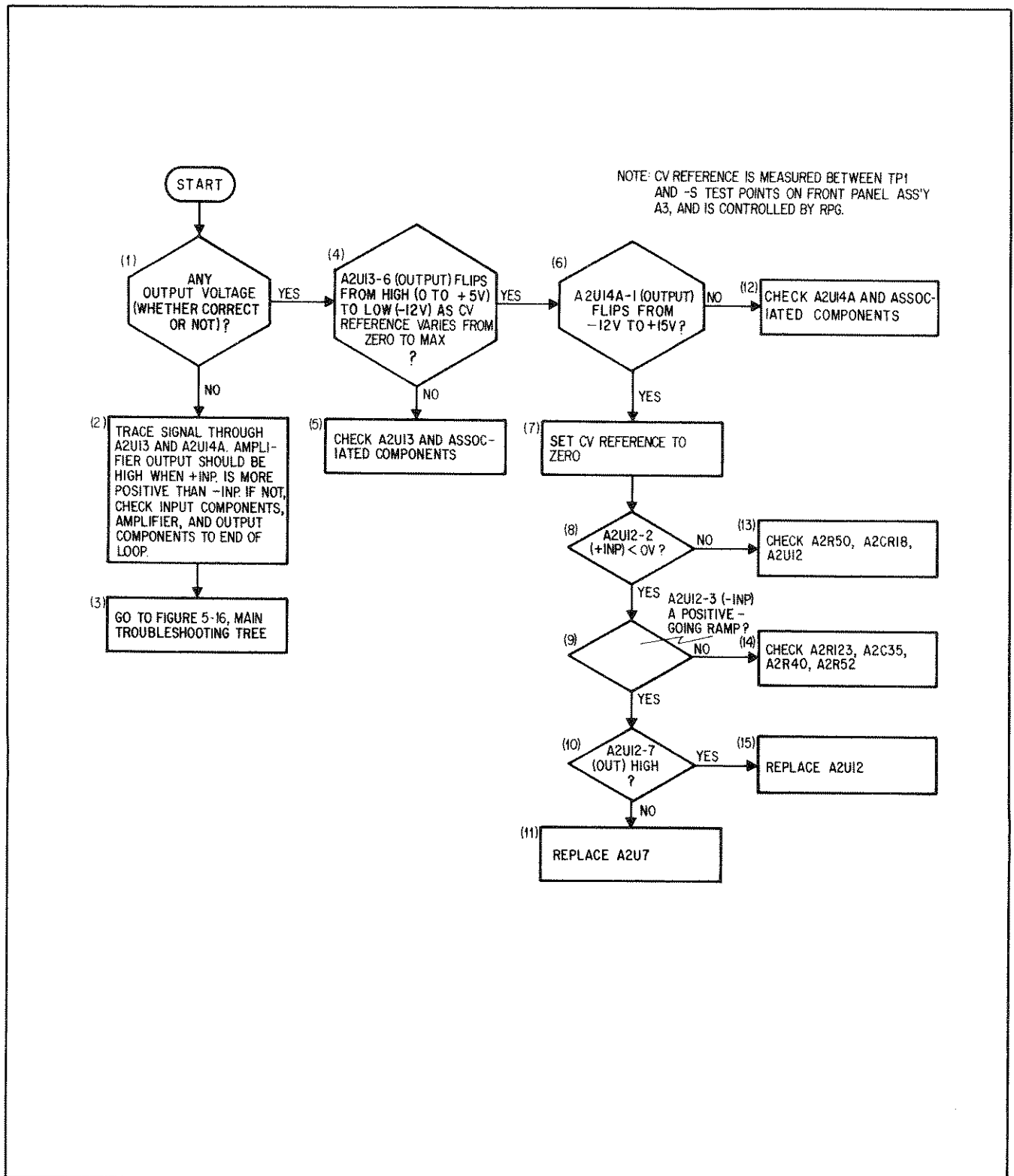

Figure 5-25. CV Circuit

NOTE: CC REFERENCE IS MEASURED BETWEEN TP3 AND OBS ON FRONT PANEL ASS'Y A3, AND IS CONTROLLED BY RPG.

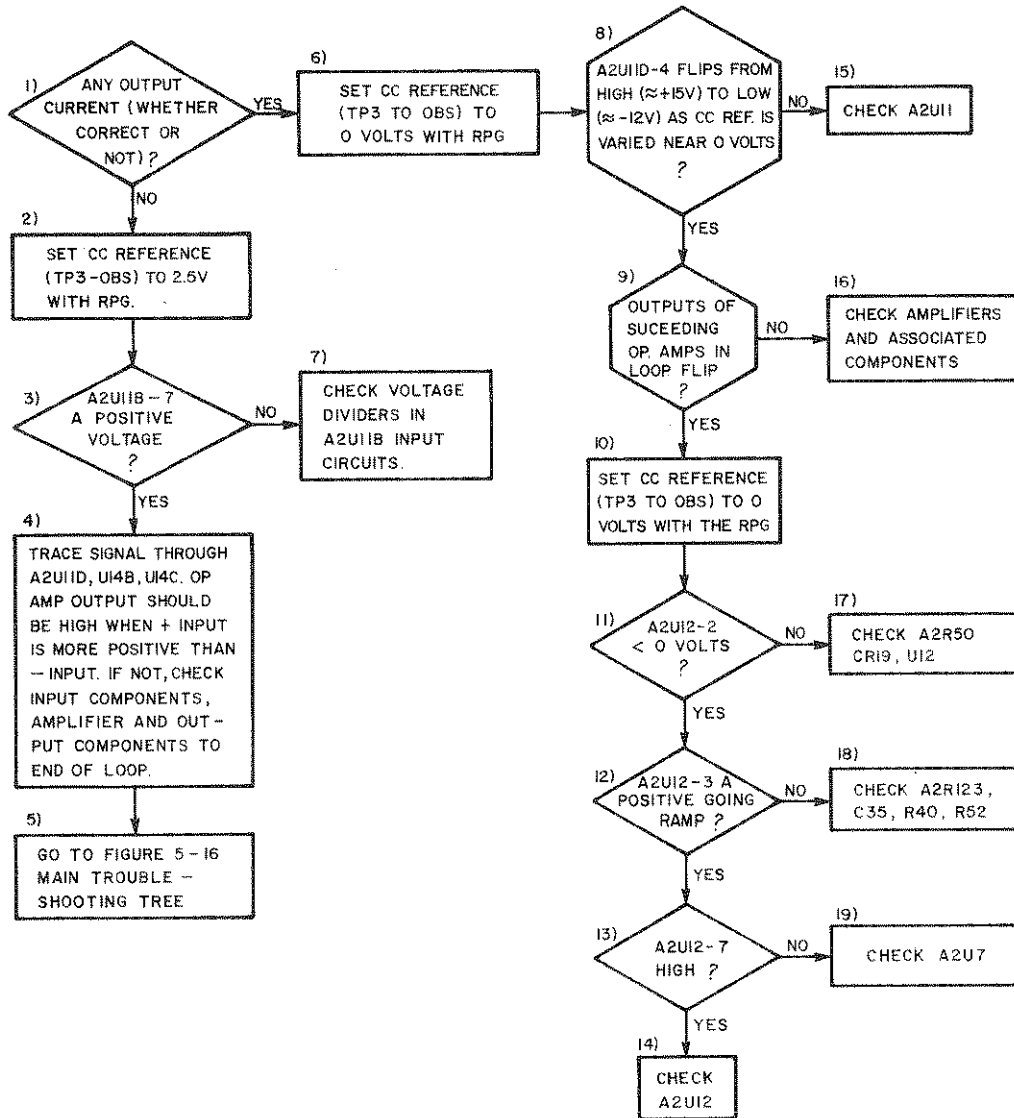

Figure 5-26. CC Circuit

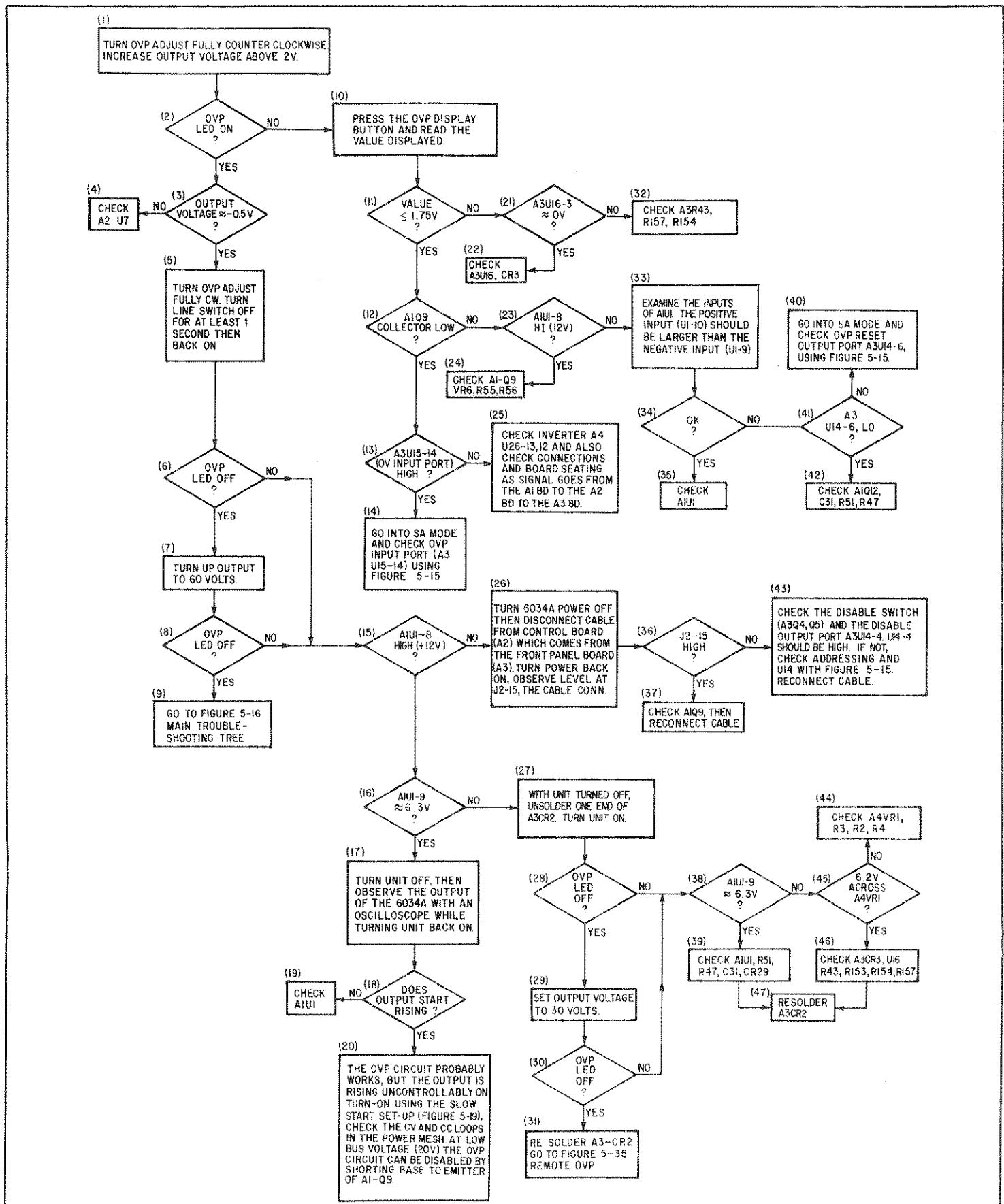

Figure 5-27. Local OVP Circuit

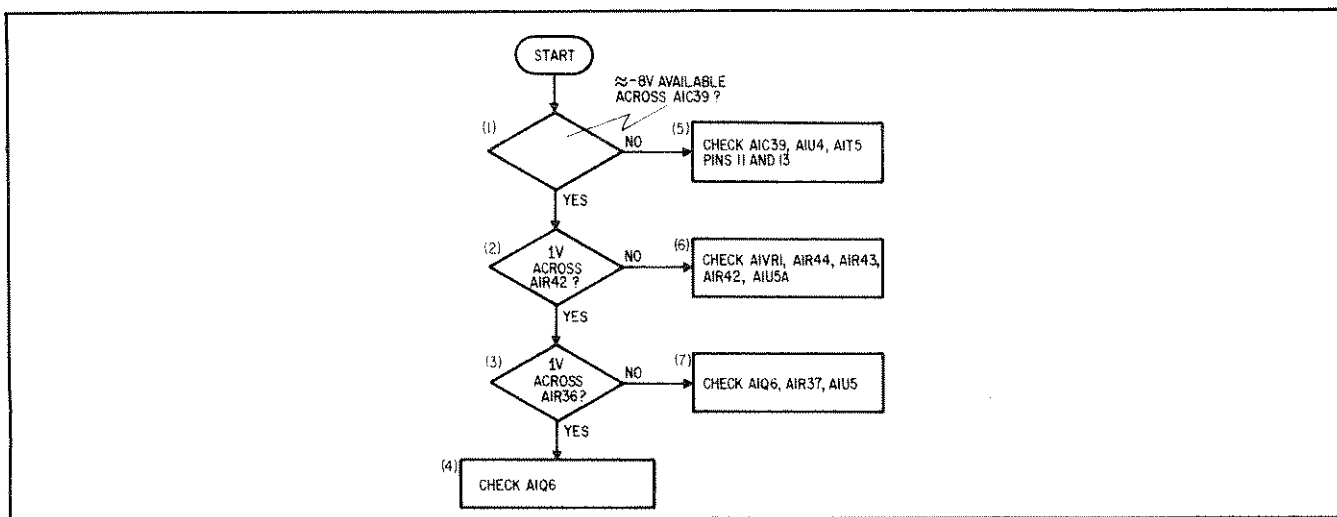

Figure 5-28. Bleed Circuit

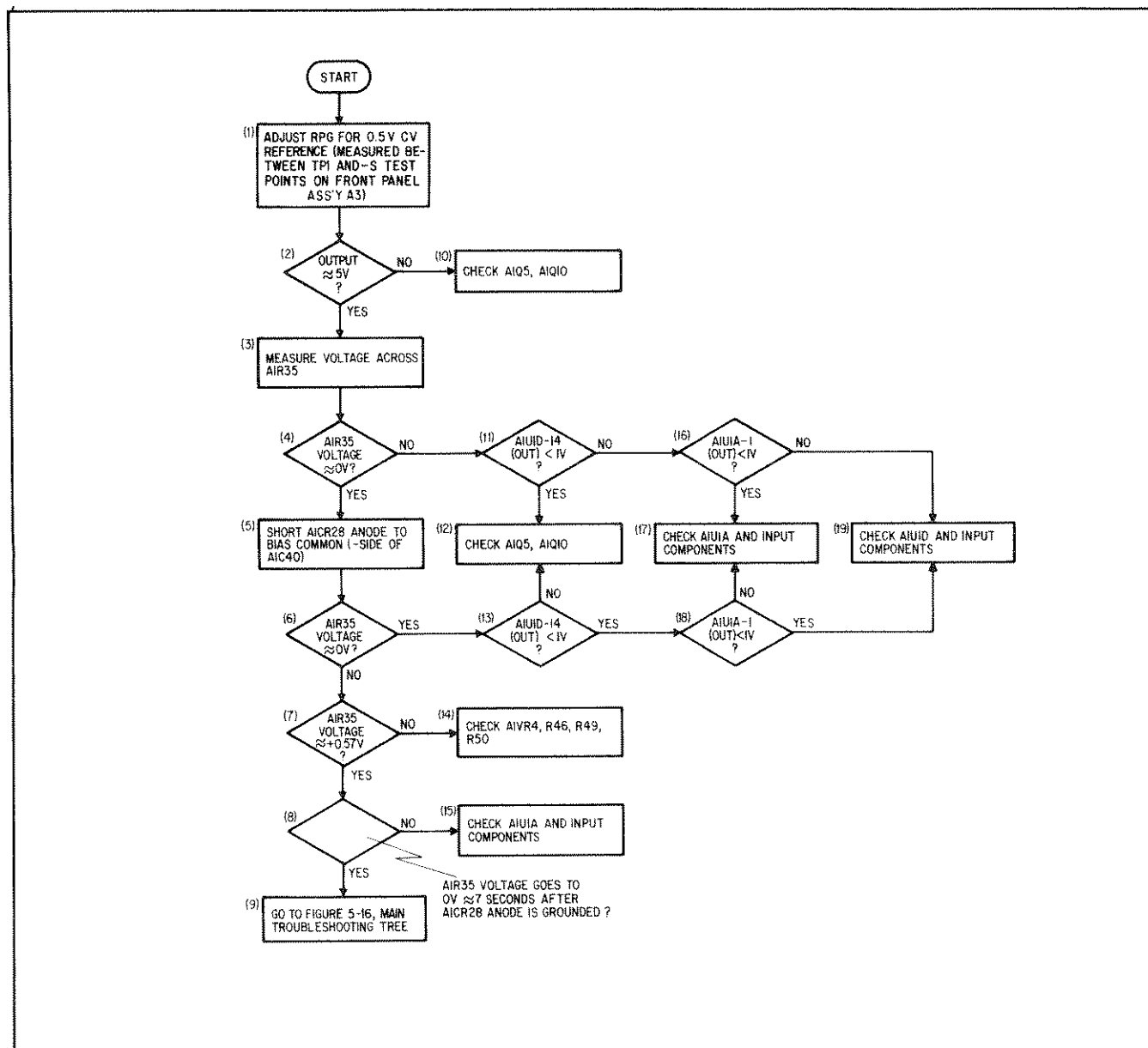

Figure 5-29. Down Programmer



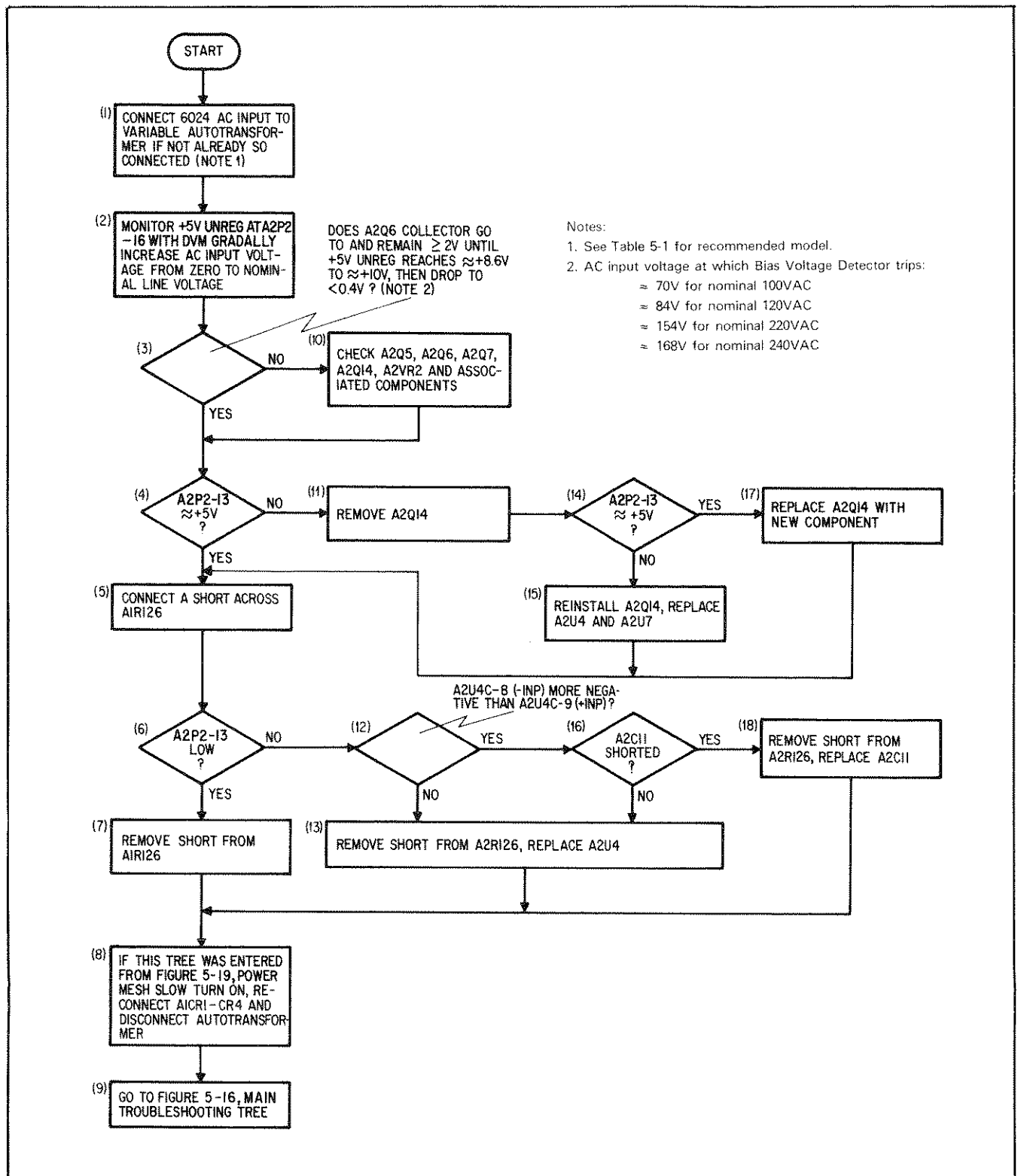
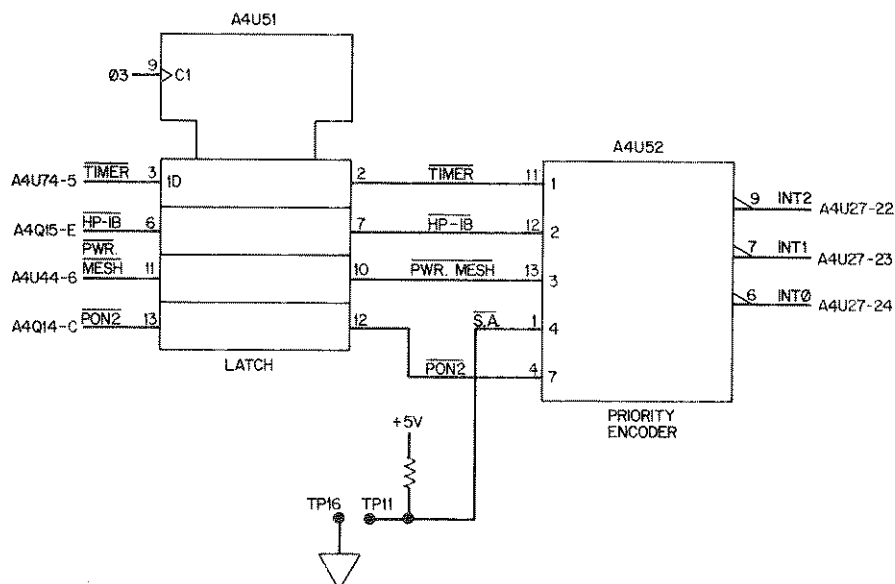

Figure 5-30. Bias Voltage/AC Dropout Detector

## INTERRUPTS TEST



When an interrupt condition occurs, it is latched into A4U51. A code corresponding to the highest priority active interrupt appears at the output of A4U52, which is connected to the interrupt inputs of the microprocessor (A4U27).

If a self test interrupt error occurs, check the lines entering A4U51. If a higher priority interrupt is stuck on, no lower priority interrupt can occur; therefore, the real problem may not be the one indicated by the self test. When self test stops on an interrupt error, the error state should continue to exist, so it can be examined. If the inputs to A4U51 are as expected according to the chart below, check A4U51, A4U52, and A4U27 (low probability that microprocessor A4U27 failure would lead user to this area).

Type of Interrupt	INTERRUPT INPUTS					INTERRUPT OUTPUTS		
	U51-13	U52-1	U51-11	U51-6	U51-3	U52-6 INT0	U52-7 INT1	U52-9 INT2
(Highest Priority) PON2	L	X	X	X	X	L	L	L
Sig. Anal.	H	L	X	X	X	L	H	H
Pwr. Mesh	H	H	L	X	X	H	L	L
HP-IB	H	H	H	L	X	H	L	H
Timer	H	H	H	H	L	H	H	L
None	H	H	H	H	H	H	H	H

If an input to A4U51 is wrong, trace the signal back to its originating circuit using the following guidelines.

Figure 5-31. Self Test Failures (Sheet 1 of 3)

**FAULT #1 POWER MESH INTERRUPT DID NOT OCCUR**

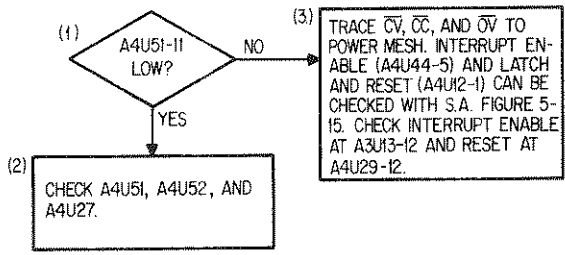

**FAULT #3 TIMER INTERRUPT DID NOT OCCUR**

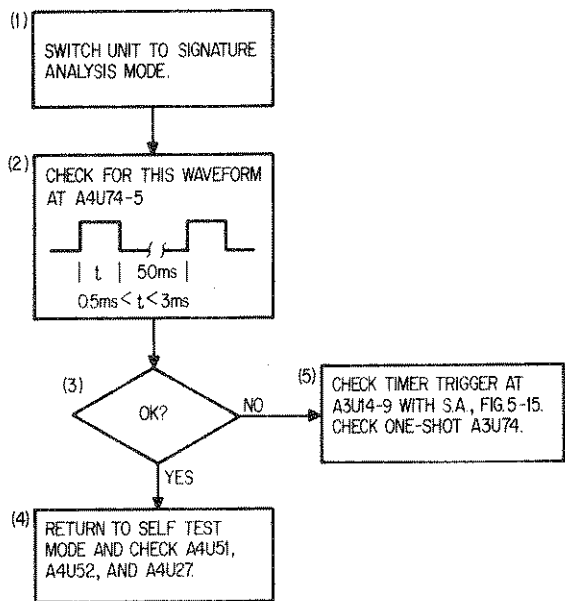

**FAULT #4 POWER MESH INTERRUPT WILL NOT CLEAR**

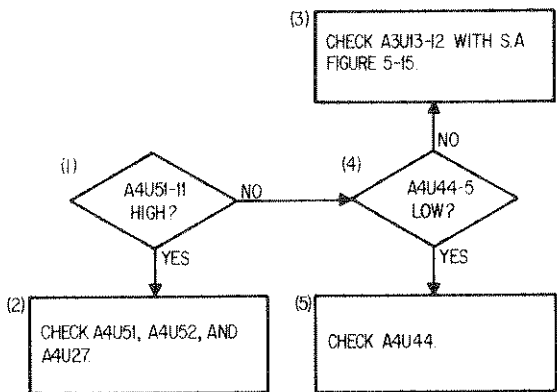

**FAULT #5 INTERRUPT OCCURRED WHEN IT SHOULD NOT**

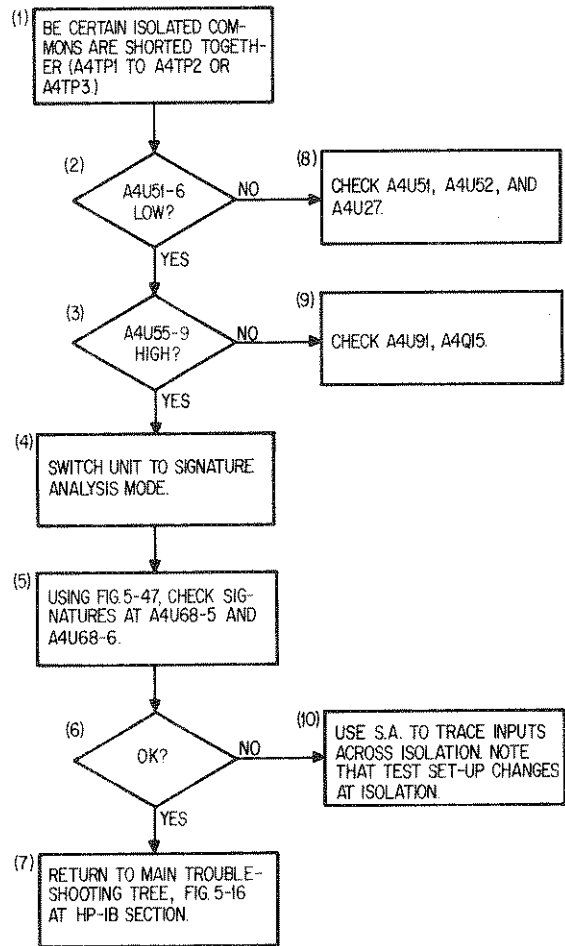

**FAULT #6 TIMER INTERRUPT TIMING WRONG**

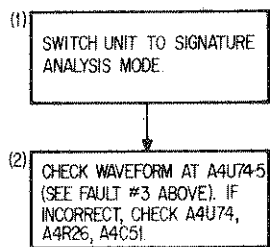
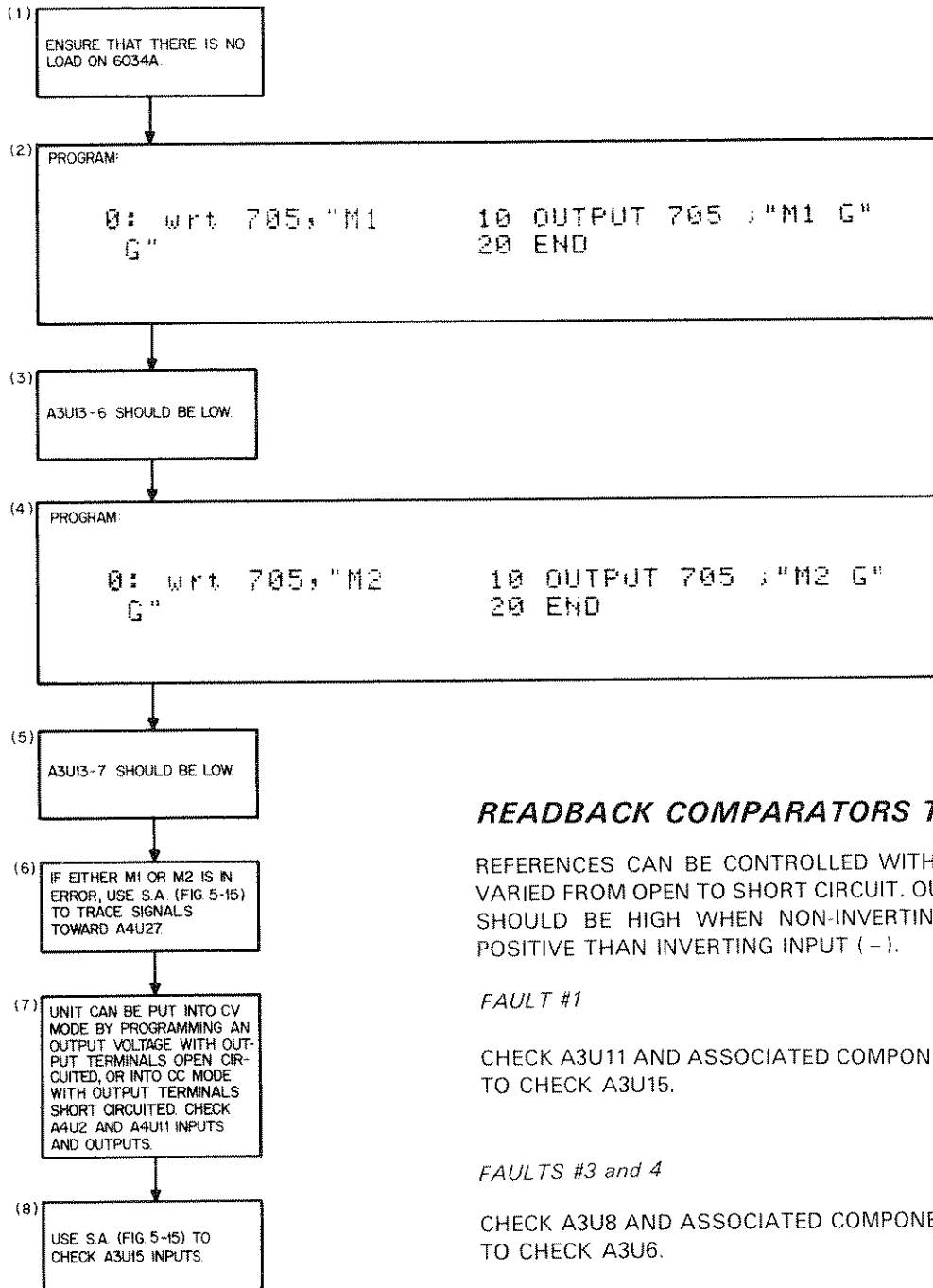

Figure 5-31. Self Test Failures (Sheet 2 of 3)

## POWER MESH MODE TEST



## READBACK COMPARATORS TEST

REFERENCES CAN BE CONTROLLED WITH RPG, OUTPUT CAN BE VARIED FROM OPEN TO SHORT CIRCUIT. OUTPUT OF COMPARATOR SHOULD BE HIGH WHEN NON-INVERTING INPUT (+) IS MORE POSITIVE THAN INVERTING INPUT (-).

### FAULT #1

CHECK A3U11 AND ASSOCIATED COMPONENTS. USE S.A. (FIG 5-15) TO CHECK A3U15.

### FAULTS #3 and 4

CHECK A3U8 AND ASSOCIATED COMPONENTS. USE S.A. (FIG 5-15) TO CHECK A3U6.

## OVP TEST

GO TO FIGURE 5-35

## HP-IB TEST

GO TO FIGURE 5-38

Figure 5-31. Self Test Failures (Sheet 3 of 3)

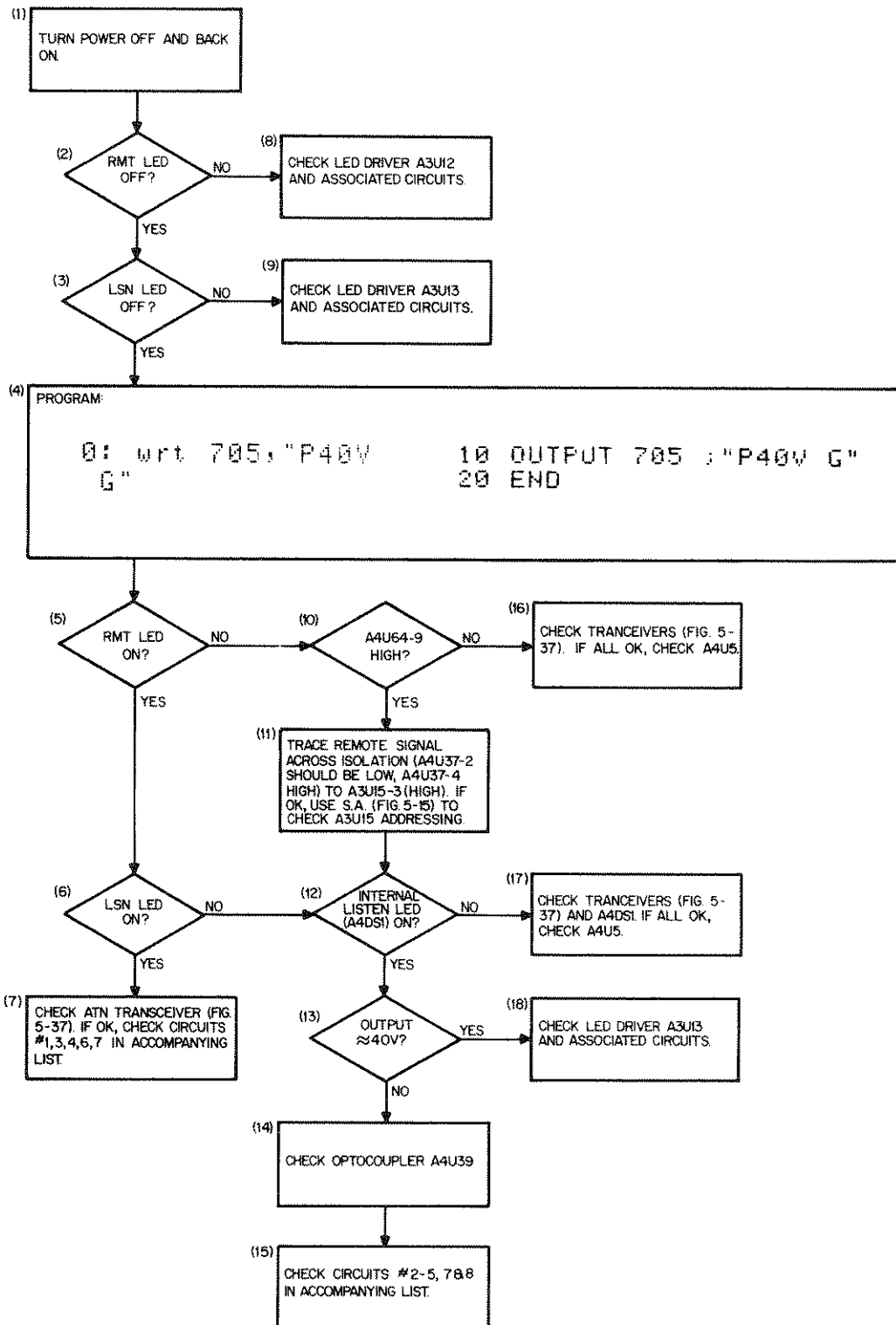

Figure 5-32. HP-IB Listen Tests (Sheet 1 of 2)

THE FOLLOWING CIRCUITS SHOULD BE CHECKED IN LISTED ORDER. AFTER ANY REPAIR, RETURN TO LISTEN TEST SECTION OF MAIN TREE. NOTE THAT IF CHI (A4U5) IS CORRECTLY DECODING LISTEN COMMANDS, A4DS1 WILL REFLECT LISTEN STATE REGARDLESS OF FRONT-PANEL LSN LED.

1. TRANSCEIVERS SEE FIGURE 5-37.

CHECK THAT DIO LINES, EOI, ATN, REN, IFC ARE GETTING TO CHI (A4U5), AND THAT 3-WIRE HANDSHAKE WORKS.

2. DEVICE CLEAR PROGRAM:

```
0: clr 7      10 CLEAR 7
1: sto 0      20 GOTO 10
              30 END
```

CHECK FOR POSITIVE PULSES AT A4U71-3 AND NEGATIVE PULSES AT A4U71-4.

3. HP-IB INTERRUPT LOOP SEE FIGURE 5-38.

USE THE DC SIGNAL PROGRAM ABOVE.

4. LOAD/SHIFT PROTECTION CIRCUIT SEE FIGURE 5-39.

USE THE DC SIGNAL PROGRAM ABOVE.

5. LISTEN MONITOR SEE FIGURE 5-40.

WHILE RUNNING THE PROGRAM IN FIGURE 5-40, ALSO CHECK TO SEE IF RMT LED GOES ON. IF NOT, TRACE REMOTE SIGNAL FROM CHI (A4U27) ACROSS ISOLATION TO I/O INPUT A3U15-3.

6. LISTEN HANDSHAKE/RECEIVE MONITOR SEE FIGURE 5-41.

7. MULTIPLEXERS AND DATA SHIFTER/OUTPUT BUFFER CIRCUITS SEE FIGURE 5-42.

8. IF ABOVE CIRCUITS ALL CHECK OUT, CHECK CRUIIN RELATED COMPONENTS IN MICROCOMPUTER SECTION.

Figure 5-32. HP-IB Listen Tests (Sheet 2 of 2)

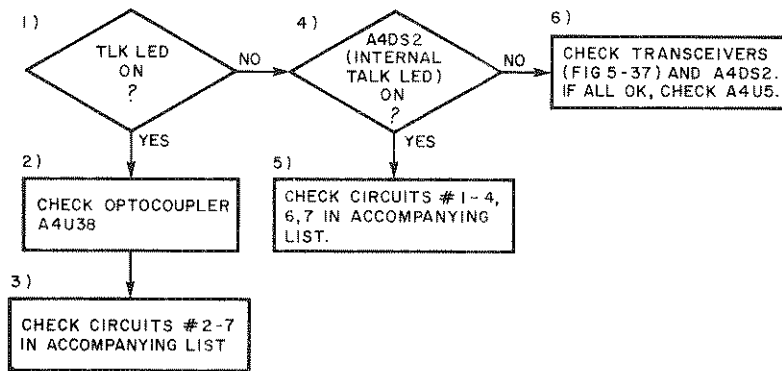

THE FOLLOWING TESTS SHOULD BE DONE ONLY IF THE LISTEN FUNCTION WORKS PROPERLY. AFTER ANY REPAIR, RETURN TO TALK TEST SECTION OF MAIN TREE. IF THE SYSTEM IS HUNG UP, TESTS 6 AND 7 MAY INDICATE STUCK HANDSHAKE LINES. NOTE THAT IF CHI (A4U5) IS CORRECTLY DECODING TALK COMMANDS, A4DS2 WILL REFLECT TALK STATE REGARDLESS OF FRONT - PANEL TLK LED.

1. TALK MONITOR SEE FIGURE 5 - 40
2. TRANSMIT ENABLE MONITOR SEE FIGURE 5 - 40
3. HP - IB INTERRUPT LOOP SEE FIGURE 5 - 38  
USING THE PROGRAMS LISTED IN FIGURE 5 - 40, CHECK THAT AN INTERRUPT OCCURS FOR BOTH TALK AND TRANSMIT ENABLE.
4. LOAD / SHIFT PROTECTION CIRCUIT SEE FIGURE 5 - 39
5. TALK HANDSHAKE SEE FIGURE 5 - 43
6. MULTIPLEXERS AND DATA SHIFTER / OUTPUT BUFFER CIRCUITS SEE FIGURE 5 - 42
7. TRANSCEIVERS SEE FIGURE 5 - 37

Figure 5-33. HP-IB Talk Tests

THE FOLLOWING TESTS SHOULD BE DONE ONLY IF THE LISTEN AND TALK FUNCTIONS WORK PROPERLY. AFTER ANY REPAIR, RETURN TO LISTEN TEST SECTION OF MAIN TREE.

1. SRQ TRANSCEIVER SEE FIGURE 5-37.  
IT IS NECESSARY ONLY TO CHECK SRQ TRANSCEIVER
2. S.P.T.E. MONITOR SEE FIGURE 5-44.
3. HP-IP INTERRUPT LOOP SEE FIGURE 5-38.  
USE THE S.P.T.E. MONITOR PROGRAM LISTED IN FIGURE 5-44.
4. LOAD / SHIFT PROTECTION SEE FIGURE 5-39.  
USE THE S.P.T.E. MONITOR PROGRAM LISTED IN FIGURE 5-44.
5. DATA SHIFTER SEE FIGURE 5-42.

Figure 5-34. Serial Poll Tests

REMOTE OVP SHOULD BE TESTED AFTER PROPER OPERATION OF LOCAL OVP HAS BEEN VERIFIED

1)

```
PROGRAM:  
0: wrt 705, "UXX. 10 OUTPUT 705 ; "UXX.XXXV G"  
   XXXV G"      20 END
```

WHERE XX.XXX IS THE SOFT VOLTAGE LIMIT ;  
THE REMOTELY PROGRAMMED OVP LEVEL IS  $2V + 1.04$   
TIMES THE SOFT VOLTAGE LIMIT.

2)

MONITOR THE REMOTE OVP REFERENCE AMPLIFIER (A3U4) OUTPUT AT A3TP6. THE VOLTAGE AT A3TP6 SHOULD BE 1/10 THE OVP TRIP VOLTAGE.

3)

CHECK THE DIGITAL INPUT TO THE OVP DAC (A4U6) IN SIGNATURE ANALYSIS MODE USING SETUP IN FIGURE 5-15.

4)

MONITOR A3TP6 WHILE VARYING OVP FULL SCALE ADJUST A3R42. IF A3TP6 DOES NOT VARY, CHECK AMPLIFIER A3U4 AND ASSOCIATED COMPONENTS.

5)

THE LOWER OF TWO OVP REFERENCE VOLTAGES (LOCAL OR REMOTE) CONTROLS OVP. TO FORCE CONTROL TO LOCAL OVP, REMOVE A3CR2. TO FORCE CONTROL TO REMOTE OVP, REMOVE A3CR3. REMEMBER TO REPLACE COMPONENTS AFTER TROUBLESHOOTING.

Figure 5-35. Remote OVP Test



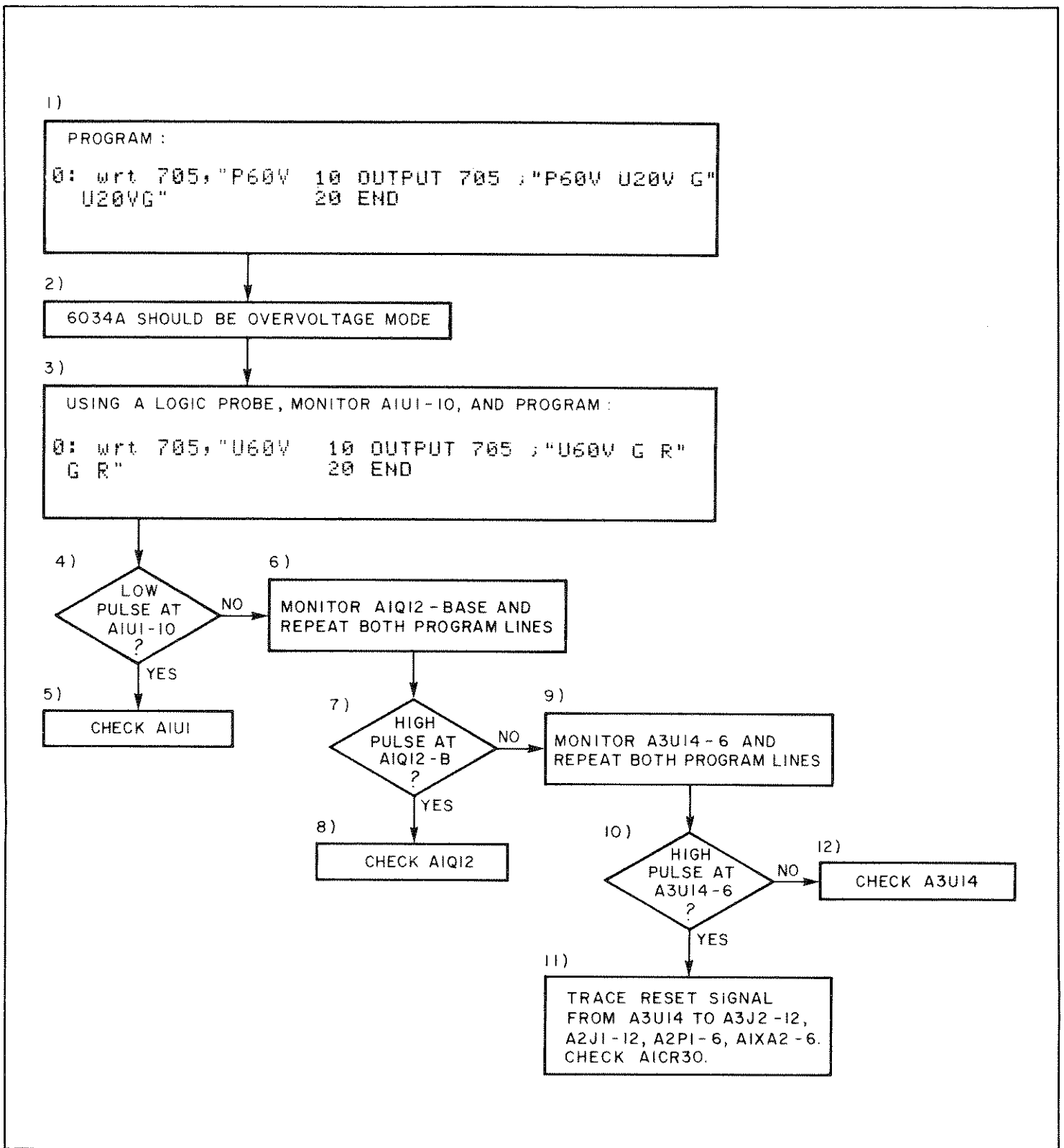

Figure 5-36. Remote OVP Reset Test

For the DIO lines, transceiver is controlled by the CHI DIO Enable output (A4U5-29). IFC, REN, and ATN buffers are always in receive mode, SRQ is always in send mode. EOI, DAV, NRFD, and NDAC transceiver direction is controlled by DAV/EOI enable; therefore, data will only flow in each direction at certain times. For example, the controller can never drive the SRQ line to the CHI, and if the CHI thinks that the 6034A is the talker, the controller cannot drive the DIO lines. To check the transceivers, test them in the listen direction first. The following program controls the DIO lines individually. Note that the controller sends its talk address before setting the DIO line. When using HP-IB register instructions it is very important to follow this protocol. If pulses are not seen on the transceiver output for the DIO line being tested, check that the data is not being lost in the interface, and that the enable line for that transceiver is low. If all data lines check out but improper data transmission is suspected, run the program for each line again and check that no other data line changes, which would indicate a short to the line under test.

#### HP-IB CONTROL LINES

Use logic probe or remove wait to use oscilloscope

```

0: cli 7
1: cmd 7,"U"
2: ent "Which
  DIO line? (1
  through 8)",L
3: if L<1 or
  L>8;eto 2
4: wti 0,7;wti
  4,2↑(L-1)
5: eto 4
10 ! DIO LINE TEST
20 ABORTIO 7 ! SENDS IFC
30 SEND 7 ; MTA ! MUST BE TALKER
40 RESUME 7 ! TURN OFF ATN
50 DISP "DIO LINE TO BE WIGGLED
  ?"
60 DISP "ENTER A NUMBER, 1 THROU
  GH 8"
70 INPUT L
80 IF L<1 OR L>8 THEN GOTO 60
90 CONTROL 7,3 ; 2^(L-1)
100 WAIT 200
110 CONTROL 7,3 ; 0
120 WAIT 200
130 GOTO 90
140 END

```

#### EOI

```

0: cli 7
1: cmd 7,"U"
2: wti 0,7;wti
  7,144;wait 500
3: wti 0,7;wti
  7,128;wait 500
4: eto 2
10 ! EOI TEST
20 ABORTIO 7
30 SEND 7 ; MTA
40 ASSERT 7,8 @ WAIT 500
50 ASSERT 7,0 @ WAIT 500
60 GOTO 40
70 END

```

#### IFC (ALSO TURNS ON REN)

```

0: cli 7;wait
  500
1: eto 0
10 ! INTERFACE CLEAR TEST
20 ! IFC BLINKS
30 ! RATHER THAN A SET LEVEL
40 ABORTIO 7
50 WAIT 500
60 GOTO 40
70 END

```

#### ATN

```

0: cli 7
1: wti 0,7;wti
  7,132;wait 500
2: wti 0,7;wti
  7,128;wait 500
3: eto 1
10 ! ATN TEST
20 ABORTIO 7
30 ASSERT 7,16 @ WAIT 500
40 ASSERT 7,0 @ WAIT 500
50 GOTO 30
60 END

```

Figure 5-37. Transceivers Circuit (Sheet 1 of 2)

REMOTE ENABLE

```

0: cli 7
1: cmd 7,"U"
2: wti 0;7;wti
  7;130;wait 500
3: wti 0;7;wti
  7;128;wait 500
4: sto 2
10 ! REMOTE ENABLE TEST
20 ABORTIO 7
30 ASSERT 7;64 @ WAIT 500
40 ASSERT 7;0 @ WAIT 500
50 GOTO 30
60 END
  
```

DAV, NDAC, NRD

All three handshake lines should have movement

```

0: cmd 7,"5"
1: sto 0
10 SEND 7 ; MLA
20 GOTO 10
30 END
  
```

6034A AS TALKER

The only difference between data readback and serial poll for the transceivers is DAV. The Serial Poll Monitor circuit drives A4U47-2 low during serial poll to prevent the 6034A from sending not-DAV. When the serial poll data has been put on the DIO lines A4U47-2 goes high. With the following program, the 6034A should drive the DIO lines, EOI, and DAV. If DAV is not being sent by the transceivers, check the DAV Enable circuit and the Serial Poll Monitor circuit.

```

0: red 705;A
10 ENTER 705 ; A
20 END
  
```

SRQ

To turn on SRQ, momentarily short A4Q2 collector to emitter. If SRQ turns on, test the rest of the circuitry by turning power off and back on. To turn off SRQ, program:

```

0: rds (705)+A
10 A=SPOLL(705)
20 END
  
```

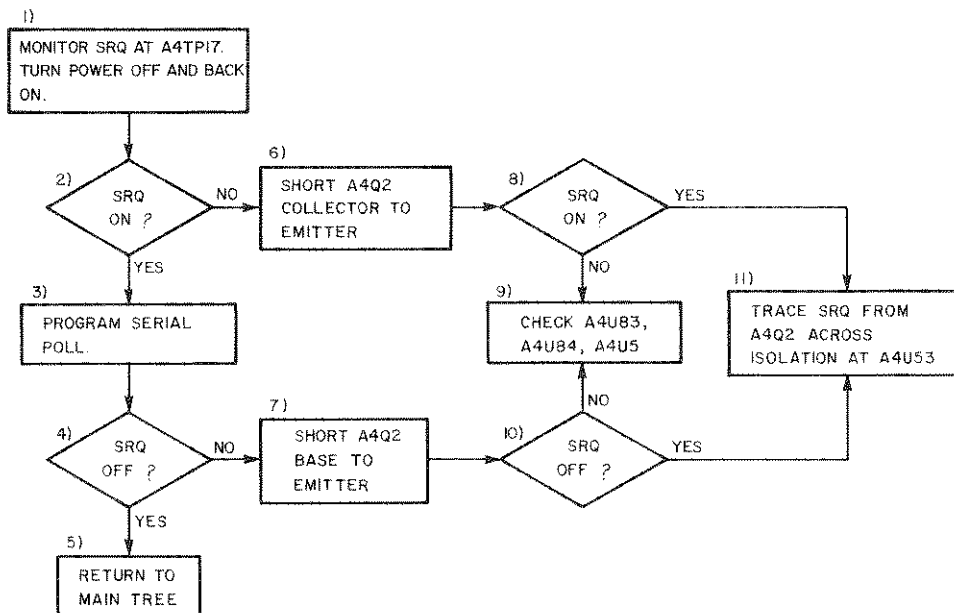

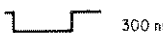
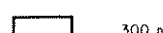



Figure 5-37. Transceivers Circuit (Sheet 2 of 2)

TO CHECK THE HP-IB INTERRUPT LOOP, CHECK PULSE WIDTHS AT LISTED LOCATIONS ON THE ANNOTATED SCHEMATIC WHILE RUNNING THE FOLLOWING PROGRAM.

```

0: clr 7      10 CLEAR 7
1: sto 0      20 GOTO 10
              30 END
  
```

- (A)  100 ns
- (B)  300 ns
- (C)  300 ns
- (D)  100 TO 500 ns
- (E) CHECK WITH SIGNATURE ANALYSIS (SEE FIGURE 5-47)

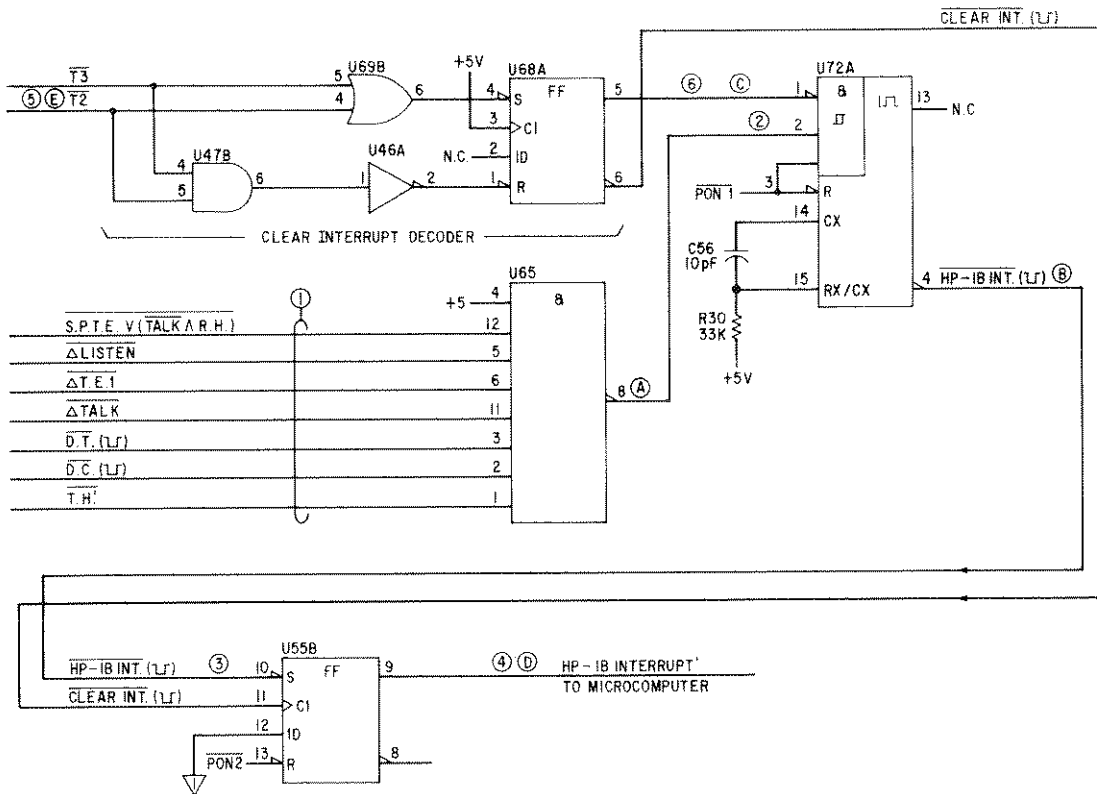

- ① INPUTS FROM CHI AND MONITOR CIRCUITS NOTE CHANGE ON HP-IB.
- ② ONE-SHOT U72A IS TRIGGERED.
- ③ BUS-INTERRUPT FLIP FLOP U55B IS SET.
- ④ MICROCOMPUTER IS INFORMED OF HP-IB INTERRUPT VIA OPTOCOUPLER.
- ⑤  $\overline{T2}$  AND  $\overline{T3}$  PULSES ARE DECODED TO CLEAR INTERRUPT.
- ⑥ U68A PREVENTS U72A FROM BEING RE-TRIGGERED UNTIL U55B IS RESET. NOTE THAT IF U65 ATTEMPTS TO TRIGGER U72A WHILE U68A-5 IS HIGH, U72A WILL BE TRIGGERED AFTER U68A-5 GOES LOW AGAIN

Figure 5-38. HP-IB Interrupt Loop

TO CHECK THE LOAD/SHIFT PROTECTION CIRCUIT, CHECK WAVEFORMS AT LISTED LOCATIONS ON THE ANNOTATED SCHEMATIC WHILE RUNNING THE FOLLOWING PROGRAM

```

0: clr 7      10 CLEAR 7
1: goto 0    20 GOTO 10
              30 END
  
```

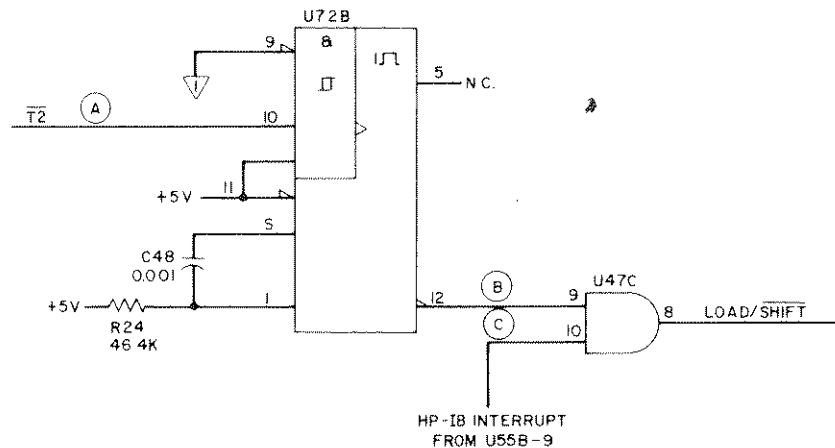
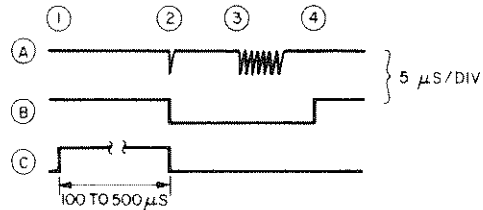

- ① HP-IB INTERRUPT OCCURS, U47C-8 GOES HIGH (LOAD).
- ② FIRST PULSE FROM T2 (WHICH LOADS THE DATA SHIFTER) TRIGGERS ONE-SHOT U72B. U47C-8 GOES LOW (SHIFT). SUBSEQUENT HP-IB INTERRUPTS CANNOT CAUSE LOAD CONDITION UNTIL U72B TIMES OUT
- ③ SEVEN PULSES FROM T2 (WHICH SHIFT DATA FROM DATA SHIFTERS ACROSS ISOLATION TO CRUIN) RE-TRIGGER U72B. U72B MUST STAY ACTIVE UNTIL AFTER SEVEN SHIFT PULSES
- ④ AFTER U72B TIMES OUT, HP-IB INTERRUPTS CAN CAUSE LOAD CONDITION

Figure 5-39. Load/Shift Protection Circuit

THE OUTPUTS OF THESE CIRCUITS GO LOW TO INDICATE A CHANGE IN THE SIGNAL FROM CHI. WHEN THE HP-IB INTERRUPT PULSE IS SENT TO THE MICROCOMPUTER THE U62 FLIP FLOPS ARE CLOCKED. THE "NEW" DATA THEN BECOMES THE "OLD" DATA, AND THE MONITORS WAIT FOR THE NEXT CHANGE. TO CHECK THE MONITORS, LOOK FOR A STREAM OF PULSES AT BOTH MONITOR OUTPUTS (TO STATUS BYTE MUX AND TO INTERRUPT NAND GATE) WHILE RUNNING THE FOLLOWING PROGRAMS.

#### LISTEN

```
0: cmd 7,"U%", "      10 SEND 7 ; UNL LISTEN 5
"                    20 GOTO 10
1: sto 0              30 END
```

#### TALK

```
0: red 705,T         10 SEND 7 ; UNT TALK 5
1: sto 0              20 GOTO 10
                      30 END
```

#### TRANSMIT ENABLE (T.E.1)

```
0: cli 7             10 SEND 7 ; UNT TALK 5
1: cmd 7,"E"         15 RESUME 7
2: wti 0,7;wti      20 GOTO 10
  7,128              30 END
3: wti 0,7;wti
  7,132
4: jmp -2
```

Figure 5-40. Listen, Talk, Transmit Enable Monitor Circuits (Sheet 1 of 2)

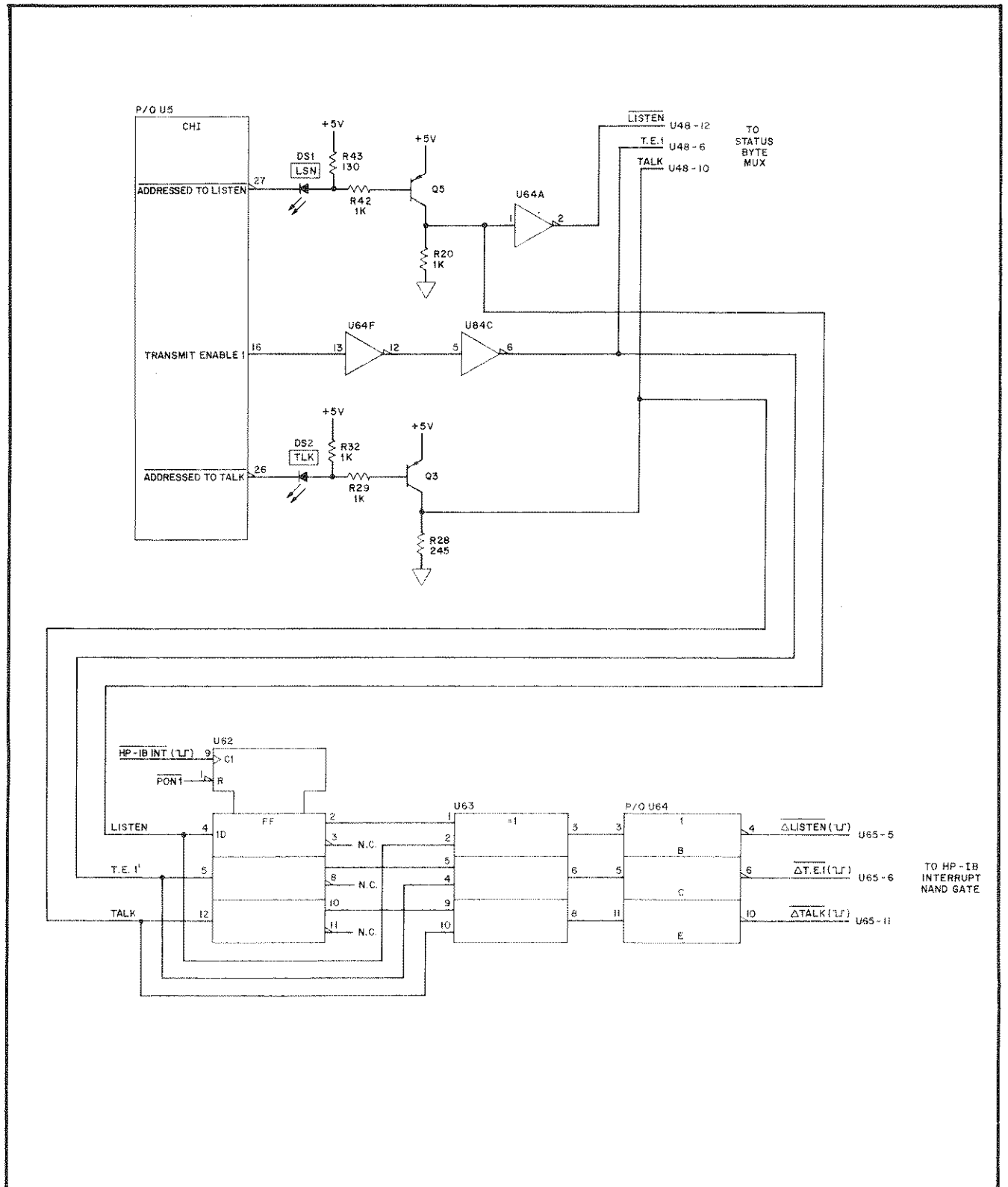

Figure 5-40. Listen, Talk, Transmit Enable Monitor Circuits (Sheet 2 of 2)

THE FOLLOWING TESTS ARE DONE IF THE 6034A WILL NOT LISTEN PROPERLY. THE TRANSCEIVERS, HP-IB INTERRUPT LOOP, LOAD/SHIFT PROTECTION, AND LISTEN MONITOR CIRCUITS SHOULD BE CHECKED FIRST, THEN, ATTEMPT TO ISOLATE THE PROBLEM TO CHI, THE TRANSCEIVERS, OR ELSEWHERE. IF CHI, THE TRANSCEIVERS, OR ELSEWHERE. IF CHI IS CORRECTLY DECODING THE LISTEN ADDRESS, A4DS1 (LISTEN) SHOULD BE LIT ON THE A4 BOARD, EVEN IF THE FRONT-PANEL LSN LED IS NOT ON. IF THE MICROCOMPUTER IS CORRECTLY DECODING THE LISTEN STATE, THE FRONT-PANEL LSN LED (A3DS18) SHOULD BE LIT. TO TEST THE LISTEN CIRCUITS, FIRST RUN THE BASIC HANDSHAKE PROGRAM AND CHECK WAVEFORMS AT THE LISTED LOCATIONS. IF CORRECT, THEN CHECK WAVEFORMS WITH THE SECOND PROGRAM.

BASIC HANDSHAKE PROGRAM :

```

0: cmd 7, "U%", "      10 SEND 7 ; MTA LISTEN 5
" "                  20 OUTPUT 7 ; " "
1: goto 0              30 GOTO 10
                       40 END

```

A4U76-6 RECEIVE READY  
A4U76-11 RECEIVE HANDSHAKE

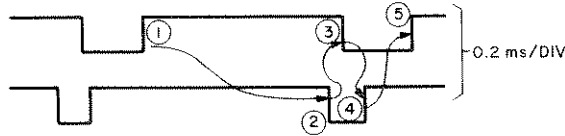

- ① 6034A IS READY TO RECEIVE A BYTE
- ② BYTE IS AVAILABLE ON DIO AND EOI LINES
- ③ 6034A ACCEPTS BYTE
- ④ BYTE NO LONGER AVAILABLE
- ⑤ 6034A IS READY TO RECEIVE ANOTHER BYTE

HANDSHAKE WITH UNLISTEN PROGRAM :

```

0: cmd 7, "?U%", "    10 SEND 7 ; UNL MTA LISTEN 5
" "                  20 OUTPUT 7 ; " "
1: goto 0              30 GOTO 10
                       40 END

```

A4U76-6 RECEIVE READY  
A4U76-11 RECEIVE HANDSHAKE  
A4U64-1 ADDRESSED TO LISTEN

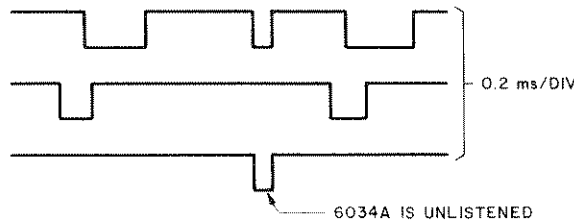

REPEAT BASIC HANDSHAKE PROGRAM TO CHECK RECEIVE HANDSHAKE MONITOR

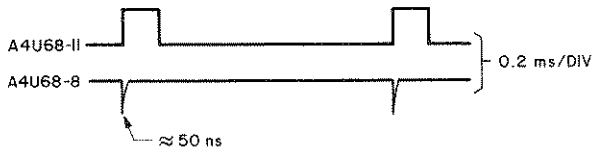

A4U68-8 GOES LOW WHEN BYTE IS AVAILABLE FOR 6034A TO READ IN. A4U68-8 RETURNS HIGH WHEN RESET BY HP-IB INTERRUPT LOOP.

Figure 5-41. Listen Handshake/Receive Monitor Circuit



THE FOLLOWING TESTS SHOULD BE DONE ONLY AFTER THE HP-IB INTERRUPT LOOP AND LOAD/SHIFT PROTECTION CIRCUITS HAVE BEEN CHECKED. THEN, CHECK A STATUS INPUT (E.G., DC) BEFORE CHECKING DATA INPUTS TO SIMPLIFY ISOLATION.

#### STATUS LINES

WHEN A MULTIPLEXER ENABLE INPUT GOES LOW, WHATEVER IS AT THE MULTIPLEXER INPUTS IS TRANSFERRED TO THE OUTPUTS. T.E.1, TALK, AND LISTEN ARE PROVIDED BY THE BUS FUNCTIONS CIRCUITS (CHI). DC, DT, SPTE, AND TRANSMIT HANDSHAKE ARE FROM THE MONITOR CIRCUITS. CHECK FOR THE FOLLOWING SIGNALS WHILE RUNNING THE APPROPRIATE PROGRAM.

TRANSMIT HANDSHAKE, T.E.1    SEE FIGURE 5-43

#### LISTEN

```
0: cmd 7, "?%"          10 SEND 7 ; UNL LISTEN 5
1: ato 0                 15 RESUME 7
                          20 GOTO 10
                          30 END
```

#### TALK

```
0: cmd 7, "_E"          10 SEND 7 ; UNT TALK 5
1: ato 0                 15 RESUME 7
                          20 GOTO 10
                          30 END
```

#### SPTE

```
0: rds(705)+R           10 R=SPOLL(705)
1: ato 0                 20 END
```

#### DC

```
0: clr 7                10 CLEAR 7
1: ato 0                 20 GOTO 10
                          30 END
```

#### DT

```
0: tra 7                10 TRIGGER 7
1: ato 0                 20 GOTO 10
                          30 END
```

Figure 5-42. Multiplexers and Data Shifter/Output Buffer Circuits (Sheet 1 of 2)

#### DATA SHIFTER

IF 6034A FAILS HP-IB SELF TEST, CHECK DATA SHIFTERS

1. SEE FIGURE 5-39 TO CHECK SHIFT CLOCK.
2. RUN A STATUS INPUT PROGRAM (E.G., DC) WHILE CHECKING BOTH SIDES OF OPTOCOUPERS A4U38 AND A4U39 WITH AN OSCILLOSCOPE. CHECK FOR SIGNAL DEGRADATION OF PULSES ACROSS OPTOCOUPERS.
3. IF NO OTHER CAUSE FOR INCORRECT DATA BEING SHIFTED IN OR OUT, REPLACE A4U40 AND A4U41.

#### DIO LINES

USE A DUAL-CHANNEL OSCILLOSCOPE, WITH TRIGGERING CHANNEL CONNECTED TO  $\overline{\text{ENABLE}}$  INPUT (PIN 1 OR 15) OF THE MULTIPLEXER BEING TESTED. IF THE  $\overline{\text{ENABLE}}$  SIGNALS ARE NOT PRESENT, TRACE BACK TO A4U71C, A4U76D, AND CHI (A4U5). USE THE SECOND CHANNEL TO MONITOR THE MULTIPLEXER INPUT/OUTPUT IN QUESTION. IF A DIO INPUT IS WRONG, CHECK THE BUS TRANSCEIVER. THE DIO LINES MAY BE STIMULATED IN THE PATTERN OF ANY ASCII CHARACTER WITH THE FOLLOWING PROGRAMS. THE CHARACTER "A" IS SENT IN THE EXAMPLE, AND IS DECODED AS 1000001.

```
0: cmd 7, "?U%",          10 SEND 7 ; UNL LISTEN 5 MTA
   "A" .                  20 OUTPUT 7 ; "A"
1: sto 0                   30 GOTO 10
                           40 END
```

Figure 5-42. Multiplexers and Data Shifter/Output Buffer Circuits (Sheet 2 of 2)

IF CHI (A4U5) IS CORRECTLY DECODING THE TALK STATE, A4DS2 (TALK) SHOULD BE LIT ON THE A4 BOARD, EVEN IF THE FRONT-PANEL TLK LED IS NOT ON. IF THE MICROCOMPUTER IS CORRECTLY DECODING THE TALK STATE, THE FRONT-PANEL TLK LED (A3DS2I) SHOULD BE LIT. TO CHECK THE TALK CIRCUITS, CHECK WAVEFORMS AT THE LISTED LOCATIONS WHILE RUNNING THE FOLLOWING PROGRAM.

```

0: dim A$(10) 10 OUTPUT 705 :A$
1: red 705,A$ 20 WAIT 10
2: wait 50 30 GOTO 10
3: goto 1 40 END

```

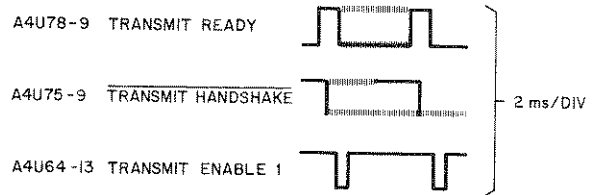

Figure 5-43. Talk Handshake/Transmit Monitor Circuit

SPT E PERFORMS THREE FUNCTIONS

- ① PUTS DATA SHIFTERS INTO PARALLEL OUTPUT MODE TO DRIVE HP-IB DIO LINES
- ② DISABLES DAV UPON RECEIPT OF SERIAL POLL
- ③ INFORMS MICROCOMPUTER (VIA A4U54 AND STATUS BYTE MULTIPLEXER) OF SERIAL POLL

CHECK LISTED WAVEFORMS WHILE RUNNING THE FOLLOWING PROGRAM.

```

0: rds(705)+A 10 A=SPOLL(705)
1: goto 0 20 GOTO 10
30 END

```

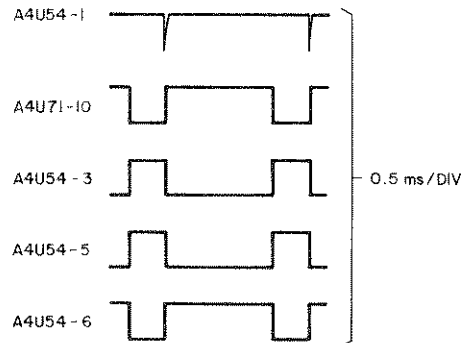

Figure 5-44. Serial Poll/S.P.T.E. Monitors

USING A LOGIC PROBE, MONITOR A4U56-9 AND PROGRAM:

```

0: clr 7          10 CLEAR 7
1: sto 0          20 GOTO 10
                  30 END
    
```

MONITOR A4U71-3 AND REPEAT PROGRAM

IF D.C PULSE IS BEING RECEIVED FROM CHI BUT IS NOT BEING SUPPLIED TO THE STATUS BYTE MUX USE THE ANNOTATED SCHEMATIC TO DETERMINE WHICH PART OF DC MONITOR CIRCUIT IS MALFUNCTIONING

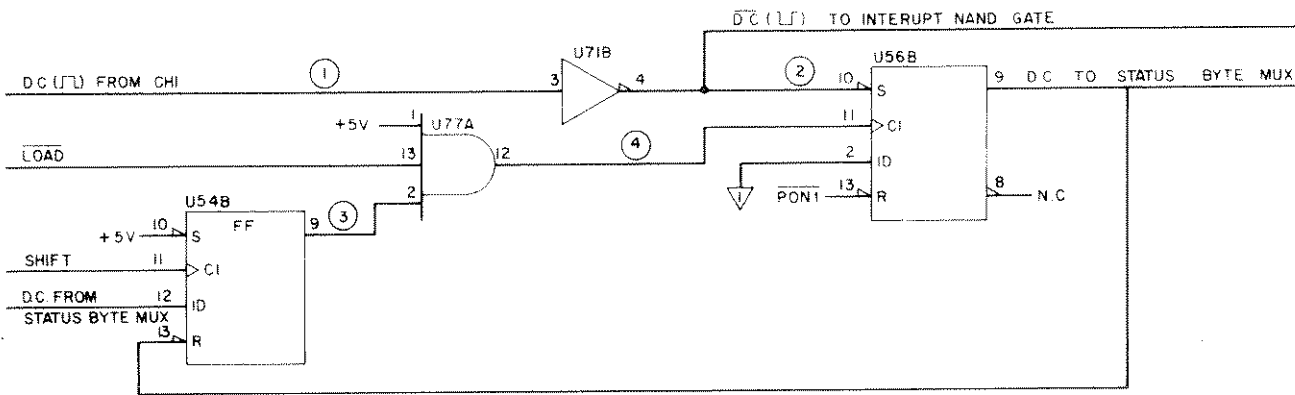

- ① PULSE IS PRODUCED AT CHI OUTPUT.
- ② FLIP-FLOP U56B IS SET, REMOVING FORCED RESET FROM U54B.
- ③ IF D.C STATUS FROM U56B-9 WAS CLOCKED INTO STATUS BYTE MUX, U54B-9 WILL BE HIGH AFTER FIRST SHIFT PULSE. HOWEVER, IF CHI PRODUCED D.C. PULSE AFTER AN HP-1B INTERRUPT WAS IN PROGRESS, U54B-12 WILL NOT BE HIGH AND U54B-9 WILL NOT GO HIGH THEREFORE, U56B WILL NOT BE RESET.
- ④ ONCE D.C STATUS IS SHIFTED INTO STATUS BYTE MUX, LOAD IS ABLE TO PASS THROUGH U77A AND CLOCK (RESET) U56B

Figure 5-45. DC Monitor Circuit

THE DT MONITOR IS SIMILAR TO THE D.C. MONITOR  
 (FIGURE 5-45). USE THE FOLLOWING PROGRAM TO  
 CHECK THE DT MONITOR.

```

0: tr# 705 10 TRIGGER 705
1: sto 0 20 GOTO 10
  
```

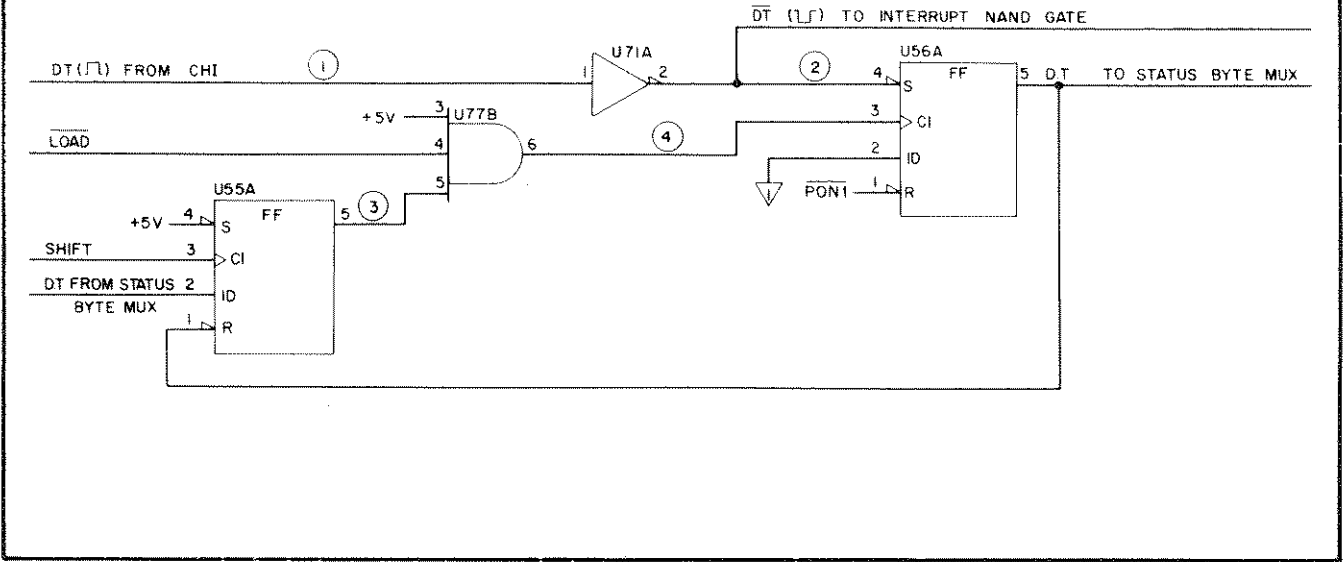

Figure 5-46. DT Monitor Circuit



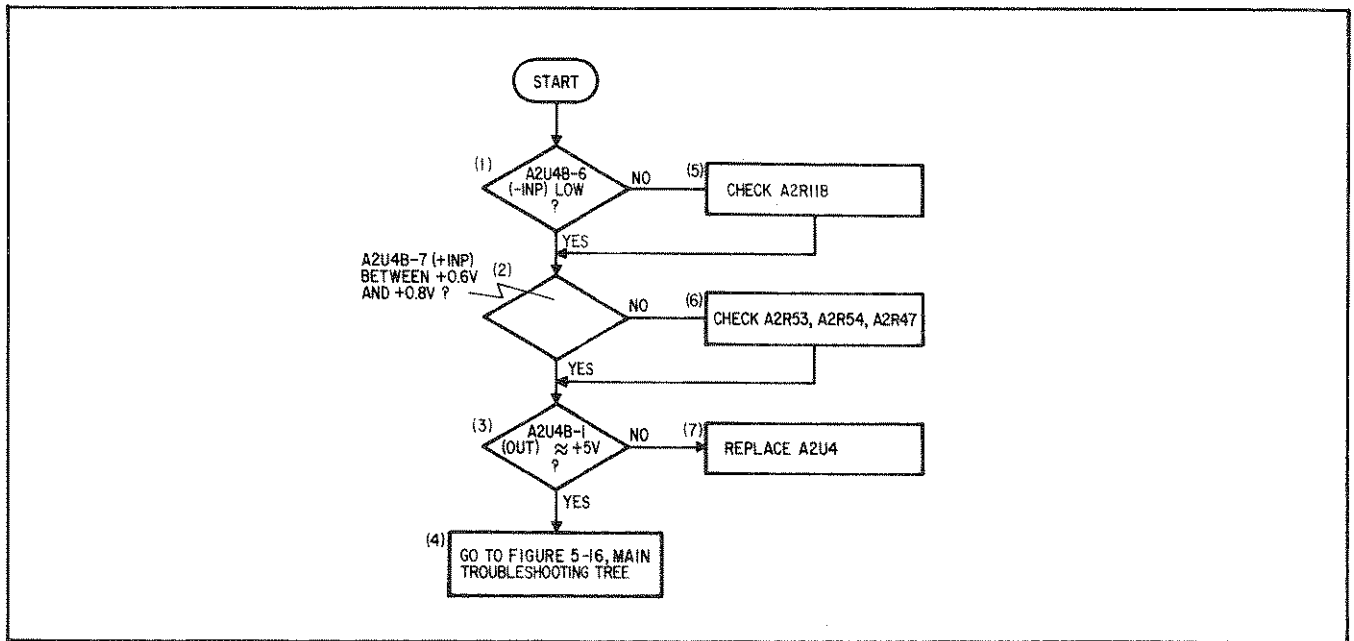

Figure 5-48. Troubleshooting Ip Limit Circuit

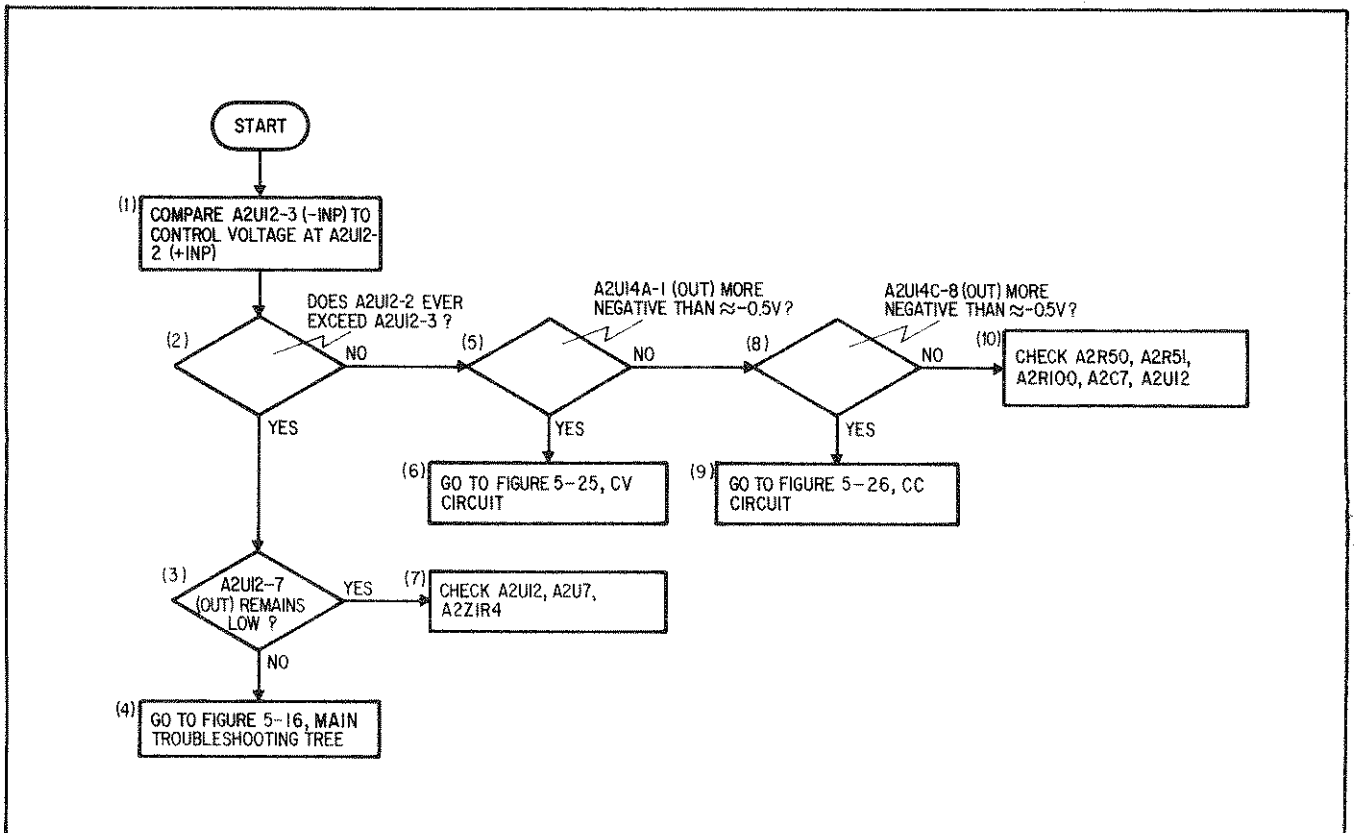

Figure 5-49. Troubleshooting Control Voltage Comparator

## 5-101 REPAIR AND REPLACEMENT

5-102 Repair and replacement of most components in the 6034A require only standard techniques that should be apparent to the technician. The following paragraphs provide instructions for removing certain assemblies and components for which the procedure may not be obvious upon inspection.

### WARNING

*To avoid the possibility of personal injury, remove the 6034A from operation before opening the cabinet. Turn off ac power and disconnect the line cord, HP-IB plug, load and remote sense leads before attempting any repair or replacement.*

### CAUTION

*When replacing any heatsink-mounted components except thermostat, smear a thin coating of heatsink compound between the component and the heatsink. If a mica insulator is used, smear a thin coating of heatsink compound on both sides of the mica insulator.*

*Do not use any heatsink compound containing silicone, which can migrate and foul electrical contacts elsewhere in the system. An organic zinc oxide cream, such as American Oil and Supply Company Heatsink Compound #100, is recommended.*

## 5-103 Front-Panel Assembly

- 5-104 To remove front-panel assembly:
1. Use 1/16" hex wrench to loosen two setscrews in OUTPUT ADJUST knob, remove knob.
  2. Loosen two front-panel screws that secure front panel to instrument.
  3. Remove four screws, one near each corner, that secure calibration panel to unit.
  4. Remove six screws that secure front-panel assembly printed-circuit board to unit (three each across top and bottom edges of printed-circuit board).
  5. Carefully pull front-panel printed-circuit assembly away from unit.
  6. To remove front-panel printed-circuit assembly completely from unit:
    - a. Unplug J3 from right side and J4 from left side of front-panel printed-circuit assembly.
    - b. Unplug J2 from control board assembly and carefully feed J2 cable through chassis. Be careful not to bend pins on J2 plug.
    - c. Unplug J1 from HP-IB microcomputer assembly. Spread connector latches at each end of J1 to release J1 from printed-circuit assembly.

- d. Unplug J5 (RPG) from back of printed-circuit board. When reconnecting J5 be certain to replace in correct position. As viewed from front, black wire is to right.
  - e. To protect components from being bent, support printed-circuit assembly in a vice designed for the purpose.
  - f. When replacing front-panel printed-circuit assembly be certain to re-connect all five connectors. Be especially careful that J2 pins are straight and properly located in control board socket before pressing J2 into socket. Remember to squeeze connector latches in to secure J1 to HP-IB microcomputer assembly socket.
7. Some components that stand up from printed-circuit assembly may be bent while handling printed-circuit assembly. Therefore, when replacing calibration panel be certain that all components that fit through holes in calibration panel (switches, LEDs, some capacitors) are properly aligned before fastening calibration panel.

## 5-105 Control Board

- 5-106 To remove control board assembly:
1. Remove top cover.
  2. Unplug J2 from control board.
  3. Remove two screws that secure control board top-support bracket to front chassis, and remove support bracket from control board.
  4. Grasp control board at top center and pull upward. Be careful no to bend any components when gripping board.
  5. When replacing control board be careful to align printed-circuit edge plug on bottom of control board in socket on power mesh assembly before pressing control board firmly into socket.
  6. Remember to load J2 cable through support bracket before re-connecting support bracket to control board and front chassis.

## 5-107 Rotary Pulse Generator (RPG)

- 5-108 To remove the rotary pulse generator:
1. Remove RPG knob, front panel, calibration panel, and front-panel printed-circuit assembly.
  2. Disconnect RPG plug from back of front-panel printed-circuit assembly.
  3. Use a 1/16" hex wrench to loosen rear setscrew on RPG shaft extension collar and remove shaft extension.
  4. Use a 1/2" socket wrench to remove RPG mounting nut from front chassis.
  5. When replacing RPG, rotate RPG so that wires are at approximately 6 o'clock position as viewed from front before tightening RPG mounting nut.
  6. Reconnect RPG plug to back of front panel. As viewed from front, black wire is to the right.



- Remember to replace shaft extension before replacing front-panel printed-circuit assembly, calibration panel, and front panel. Be certain that all components on printed-circuit assembly that fit through holes in calibration panel are properly aligned before fastening calibration panel.

### 5-109 Power Mesh Thermal Resistors

5-110 When replacing RT1 and RT2 on the power mesh assembly, unsolder component leads from the standup terminals on the printed-circuit board; do not remove the standup terminals. Carefully preform the replacement-component leads. To avoid breaking leads off the component, do not bend the leads at the component.

### 5-111 Current-Monitor Resistor Heatsink

5-112 A heatsink bar extends upward from the power mesh printed-circuit board at the outboard junction of R28 and R29. The top end of the bar is bent over into the top of R28 for support. Remove the heatsink bar before replacing R28. After replacing R28, replace heatsink bar with bent end fitted inside the top of R28.

### 5-113 A5 Regulator

5-114 The A5 regulator assembly is mounted on the center chassis, which acts as a heatsink for the two regulator transistors. Figure 5-50 shows how the regulator assembly is mounted. If one or both of the regulator transistors has to be replaced, remove only the transistors, not the printed-circuit assembly, as follows:

- Remove two screws that secure each transistor to the unit.
- The transistors plug into sockets on the printed-circuit assembly. Carefully pull the transistor away from the printed-circuit assembly. If necessary to pry the transistor out, be very careful not to damage the mica insulator between the transistor and chassis.
- Do not forget to replace mica insulator when replacing transistor. Use a small amount of heatsink compound on both sides of mica insulator (see CAUTION in paragraph 5-102 concerning heatsink compound).
- Be certain pins are straight before replacing transistors. Be very careful that pins are properly aligned in printed-circuit assembly sockets before pressing transistor into place.

5-115 To remove the regulator assembly, first remove the two transistors. Proceed as follows:

- Unsolder six wires from printed-circuit assembly.
- Remove two screws that secure printed-circuit assembly to center chassis.
- When replacing assembly be careful to replace insulator board and two plastic insulators. The insulator board has an 1/8" square soldered hole in

one corner. This square should be at the top front when the insulator board is replaced. Plastic insulators should be replaced with studs protruding through insulator board and center chassis.

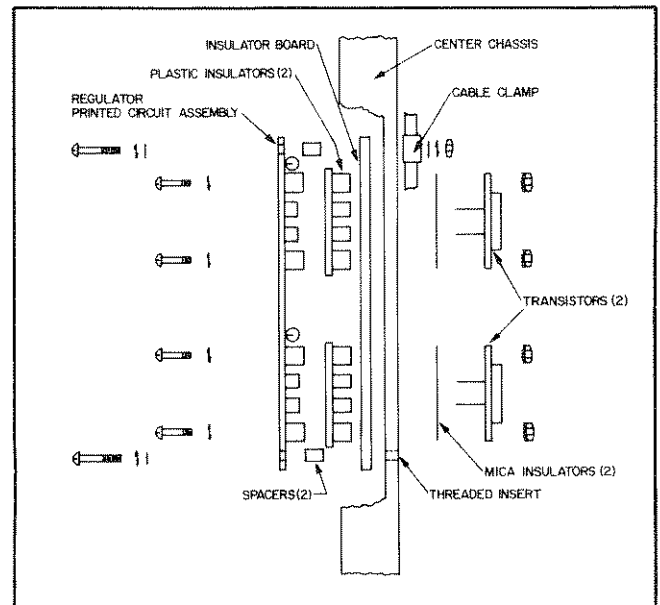

Figure 5-50. A5 Regulator Assembly

### 5-116 HP-IB Bias Power Supply Repair

5-117 If any components are replaced in the HP-IB +5 volt or +12 volt bias power supplies, the output of the +5 volt supply should be checked. Proceed as follows:

- Bias power supply output jumpers J5 should still be removed from troubleshooting. Otherwise, remove the three J5 jumpers from the HP-IB bias power supply on the A4 assembly.
- Turn on unit and check output of HP-IB +5 volt bias power supply; it should be  $\pm 5\%$  (+4.75 to +5.25 volts). Turn off unit and disconnect line cord.
- If +5 volt output is too high, remove jumper W16 installed on A4 assembly.
- If +5 volt output is too low, install a jumper wire for W16 on A4 assembly.
- Replace bias power supply output jumpers only after checking that bias power supply output voltages are correct.

### 5-118 REPLACEMENT PARTS

5-119 Section VI of this manual contains a list of replacement parts. If a part does not have a standard manufacturer's part number, it is a special part and must be ordered directly from Hewlett-Packard.

5-120 Some components are mounted with spacers, insulators, etc. on leads. Be certain to note location of all mounting pieces before removing a component, and replace all pieces in proper location.

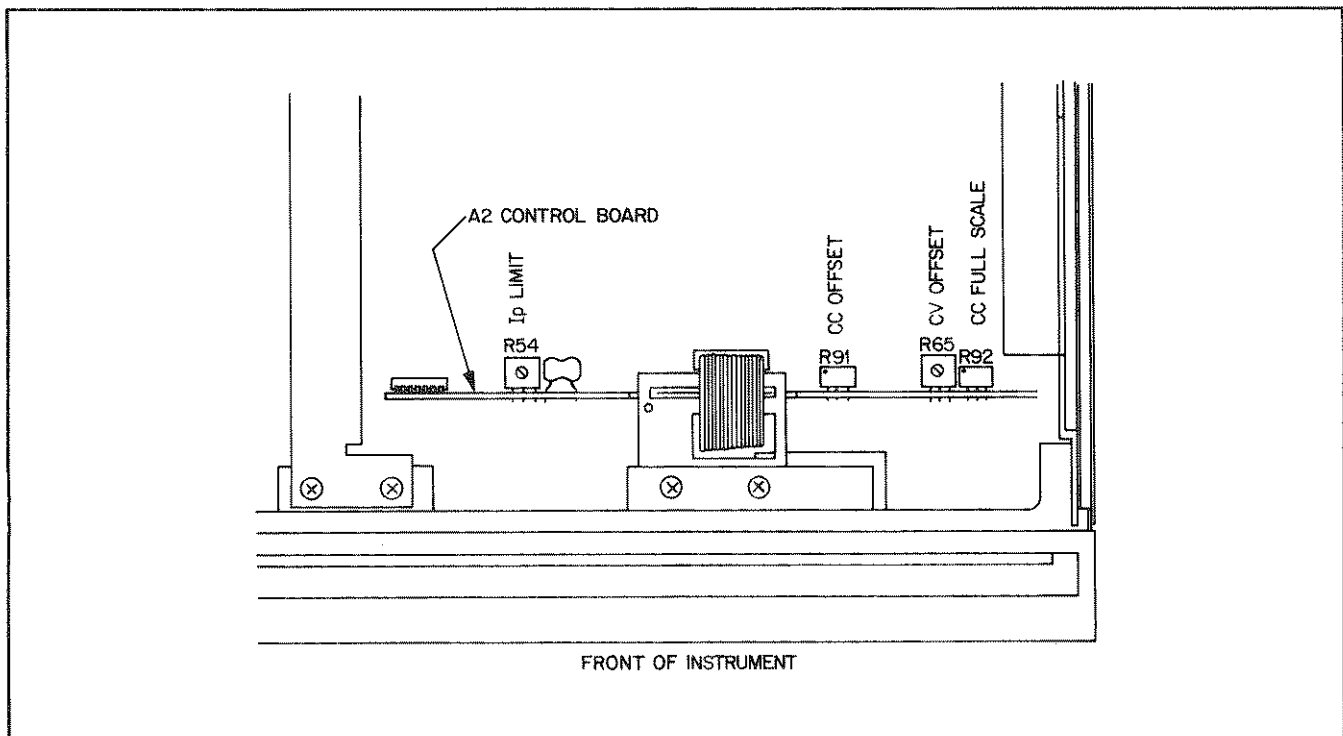

Figure 5-51. A2 Control Board Calibration Potentiometers

## 5-121 CALIBRATION

5-122 Calibration procedures for the 6034A are of two types, routine and service. Routine calibration consists of those procedures which can be done at the front calibration panel without removing the instrument from the rack. Routine calibration can be done whenever it is desired to check the unit's calibration. No routine calibration interval is recommended. Service calibration consists of all the routine calibration procedures plus procedures that can only be done by removing the top cover of the instrument. The complete service calibration should be done, in the order presented, after any repair. Procedures that are to be done only for service calibration are noted in the following paragraphs.

### 5-123 Initial Setup

- Use 1/16" hex wrench to loosen two setscrews in OUTPUT ADJUST knob, remove knob.
- To gain access to calibration panel, loosen two screws that secure front panel to instrument.
- Turn OVP ADJUST control (A3R43) fully clockwise.
- Strap unit for local sensing (rear panel + S to +, - S to -).
- Disconnect all loads from output terminals.
- Connect an HP-IB controller (HP9825 or HP85 recommended) to the 6034A.
- Turn on ac power.
- Allow unit to warm up for 30 minutes.
- To perform service calibration, remove top cover of instrument.
- Figure 5-51 shows the location of potentiometers used for service calibration on the A2 control board.

- To allow easy connection of test probes to control board test points, remove control board top support bracket, and plug test connector HP part no. 1251-6016 onto control board.
- Turn off ac power when making or removing connections to 6034A.

### WARNING

*Procedures described herein are performed with power supplied to the instrument, and protective covers removed. Such procedures should be performed only by service-trained personnel who are aware of the hazards involved (for example, fire and electrical shock). Where procedures can be performed without power applied, the power should be removed.*

### 5-124 Remote OVP Calibration

- Ensure that front-panel OVP ADJUST control (A3R43) is turned fully clockwise.
- Connect DVM between test points TP6 and OBS on front-panel assembly.
- Adjust A3R42 (OVP FULL SCALE) for  $+6.45 \text{ V} \pm 0.02 \text{ V}$ .

### 5-125 Ip Limit Calibration

5-126 Ip limit calibration should be performed only during complete service calibration.

- Connect test setup as shown in Figure 5-2. Open switch S1. The load resistor should be set for less than  $1\Omega$ .

- b. Connect 6034A ac input to a variable autotransformer set for low-line ac input voltage (see paragraph 2-20).
- c. Turn A2R54 fully counterclockwise.
- d. Turn A2R92 (17-turn potentiometer) fully counterclockwise. Note that this puts constant current circuit out of calibration, and constant current circuit **must be recalibrated** after Ip limit is calibrated.
- e. Press front-panel LCL pushbutton switch to put 6034A into local mode.
- f. Use RPG to adjust output voltage to  $+24\text{ V} \pm 0.1\text{ V}$ .
- g. Connect DVM across shunt. Close switch S1.
- h. Use RPG to adjust output current so that DVM reads  $100\text{ mV} \pm 1\text{ mV}$  ( $10\text{ A} \pm 0.1\text{ A}$  through shunt). 6034A should be in CC (LIMIT) mode.
- i. Turn A2R54 fully clockwise.
- j. Connect DVM across sense terminals.
- k. Adjust load resistor for  $+23\text{ V} \pm 0.1\text{ V}$  on DVM. 6034A should remain in CC (LIMIT) mode.
- l. **Slowly** adjust A2R54 counterclockwise just until UNREGULATED LED turns on.
- m. DVM should indicate  $+23\text{ V} \pm 0.3\text{ V}$ . If not, repeat procedure with care.

### 5-127 Regulation Adjustment

- a. Connect test setup shown in Figure 5-2.
- b. Send string "P20V C10A M1 G" to 6034A. This sets output voltage to 20 V with a 10 A current limit. 6034A should be in CV (NORMAL) mode.
- c. Connect DVM across  $R_M$ .
- d. Adjust R1 until DVM indicates  $0.09\text{ V} \pm 0.001\text{ V}$  ( $9\text{ A} \pm 0.1\text{ A}$  through shunt). 6034A should remain in CV (NORMAL) mode.
- e. Disconnect DVM from  $R_M$  and connect it to 6034A sense terminals.
- f. Open switch S1 to disconnect load.
- g. Record the reading on DVM.
- h. Close switch S1 to reconnect load.
- i. Wait a few seconds for 6034A to settle. Adjust A3R78 (REGULATION) so that reading on DVM differs from reading recorded in step g by less than  $\pm 0.3\text{ mV}$ .

### 5-128 Constant Voltage Circuit Calibration

5-129 In the following procedure, only steps b, d, f, g, and h should be done, in order, for routine calibration. If any repair has been done, or if the routine calibration procedures are insufficient to achieve the correct test results, perform the complete service calibration procedure.

- a. Connect DVM across points 1 and 2 on A2 control board edge test connector.
- b. Send string "POV C1A M1 G" to 6034A. This sets output voltage to 0 V with a 1 A current limit. 6034A should be in CV (NORMAL) mode.
- c. Adjust A3R7 (CV ZERO) for less than  $\pm 1.5\text{ mV}$  on DVM.
- d. Connect DVM across sense terminals.

- e. Adjust A2R65 for less than  $\pm 1.5\text{ mV}$  on DVM.
- f. Adjust A3R7 (CV ZERO) for less than  $\pm 1.5\text{ mV}$  on DVM.
- g. Send string "P60V C1A M1 G" to 6034A. This sets output voltage to 60 V with a 1 A current limit. 6034A should remain in CV (NORMAL) mode.
- h. Adjust A3R81 (CV FULL SCALE) for  $60\text{ V} \pm 3\text{ mV}$  on DVM.

### 5-130 Constant Current Circuit Calibration

5-131 In the following procedure, only steps c, d, e, f, g, and j should be done, in order, for routine calibration. If any repair has been done, or if the routine calibration procedures are insufficient to achieve the correct test results, perform the complete service calibration procedure.

- a. Connect DVM across rear-panel terminals A1 and A2.
- b. Adjust A2R91 for less than  $\pm 1\text{ mV}$  on DVM.
- c. Connect  $0.01\Omega$  shunt across output terminals.
- d. Connect DVM across shunt.
- e. Send string "P1V COA M2 G" to 6034A. This sets output current to 0 A with 1 V voltage limit. 6034A should be in CC (NORMAL) mode.
- f. Adjust A3R96 (CC ZERO) for less than  $\pm 5\mu\text{ V}$  on DVM (less than  $\pm 0.5\text{ mA}$  through shunt).
- g. Send string "P1V C10A M2 G" to 6034A. This sets output current to 10 A with a 1 V voltage limit. 6034A should be in CC (NORMAL) mode. Wait 30 seconds for current-monitor resistors to settle.
- h. Adjust A3R82 (CC FULL SCALE) to approximate center of rotation. Wait 30 seconds for current-monitor resistors to settle.
- i. Adjust A2R92 for  $100\text{ mV} \pm 0.05\text{ mV}$  on DVM ( $10 \pm 0.005\text{ A}$  through shunt).
- j. Adjust A3R82 for  $100\text{ mV} \pm 0.01\text{ mV}$  on DVM ( $10 \pm 0.001\text{ A}$  through shunt).

### 5-132 Front-Panel Voltmeter Calibration

#### NOTE

*The following procedure for calibrating the front-panel voltmeter requires a precision voltage source. If one is not available, the voltmeter can be calibrated by programming 60 volts and adjusting A3R4 until the front-panel voltmeter matches a DVM across the output. For many systems applications, this adjustment will be accurate enough, even though the front-panel voltmeter will not be calibrated to specification.*

- a. Turn off the 6034A.
- b. Remove strap between +sense and +output terminals.
- c. Connect a short between +output and -output terminals.
- d. Connect positive output terminals of 6116A precision voltage source to +sense terminal of 6034A. Connect negative output terminal of 6116A to the -sense terminal of 6034A. Do not turn on 6116A.

- e. Connect DVM across sense terminals of 6034A.
- f. Send string "P60V C1A M2 G" to 6034A. This sets output current to 1 A with a 60 V voltage limit. 6034A should be in CC (NORMAL) mode.
- h. Turn on 6116A. Adjust output of 6116A for 19 V  $\pm 0.001$  V on DVM.
- i. Adjust A3R4 (VOLTMETER FULL SCALE) for 19.00 on front-panel voltmeter.
- j. Turn off 6116A. Turn off 6034A. Disconnect test setup and reconnect strap between +sense and +output terminals of 6034A.

### 5-133 Front-Panel Current Meter Calibration

- a. Disconnect all loads from output terminals.
- b. Adjust A3R3 (CURRENT METER ZERO) for a reading of 0.00 A on front-panel current meter.
- c. Connect a 0.01 $\Omega$  shunt across output terminals.
- d. Connect DVM across shunt.
- e. Send string "P1V C10A M2 G" to 6034A. This set output current to 10 A with a 1 V voltage limit. 6034A should be in CC (NORMAL) mode.
- f. Adjust R8 (CURRENT METER FULL SCALE) so that front-panel current meter reading equals DVM reading divided by resistance of shunt. For a 0.01 $\Omega$  shunt, simply shift the DVM reading decimal point two places to the right.

### 5-134 Remote Current Meter Calibration

- a. Connect a 1 k 1% 1/8 W metal film resistor (or equivalent) across output terminals.
- b. Send string "P3.75 V C0.1 A M1 G" to 6034A. This sets output voltage to 3.75 V with a 0.1 A current limit. 6034A should be in CV (NORMAL) mode.
- c. Run test program shown in Figure 5-52. Controller will display NAXx.xxx, where xx.xxx is current reading returned by the 6034A over the HP-IB.
- d. Adjust A3R90 (REMOTE CURRENT METER ZERO) so that current reading displayed on the controller is NA00.002.

### 5-135 Remote Voltmeter Zero Calibration

- a. Connect a one-foot length of AWG #26 solid copper wire (0.41mm diameter) across output terminals. The exact length and size of the wire is not critical; the object is to obtain approximately 25 milliohms load resistance.
- b. Connect DVM across 6034A sense terminals.
- c. Press front-panel LCL pushbutton switch to put 6034A into local mode.
- d. Use RPG to increase output voltage until 6034A switches to CC (LIMIT) mode.
- e. Use RPG to adjust output current so that DVM indicates 22.5 mV  $\pm 0.1$  mV.
- f. Run test program shown in Figure 5-52. Controller will display NAXx.xxx, where xx.xxx is current reading returned by the 6034A over the HP-IB.
- g. Adjust A3R89 (REMOTE VOLTMETER ZERO) so that reading displayed on controller is NV00.015.

```

9825 Computer
0: dim A$(8)           string variable to put reading in
1: dev "PS",705       98034A select code 7,
                     6034A is PS at HP-IB address 5
2: "loop"
3: wrt "PS","T"      tell supply to take reading,
4: red "PS",A$       put reading in A$,
5: dsp A$            display reading,
6: goto "loop"       and repeat.

HP85 Computer
10 DIM A$(8)
20 loop
30 OUTPUT 705;"T"
40 ENTER 705;A$
50 DISP A$
60 GOTO 20

```

Figure 5-52. Calibration Test Programs

### 5-136 Remote Voltmeter Full Scale Calibration

#### NOTE

*The following procedure for calibrating remote voltage readback requires a precision voltage source. If one is not available, follow steps a, c, e, f, g, i, j, and k in the following procedure. For many applications, this adjustment will be accurate enough, even though the voltage readback will not be calibrated to specification.*

- a. Turn off the 6034A.
- b. Remove strap between +sense and +output terminals.
- c. Connect a short between +output and -output terminals.
- d. Connect positive output terminal of 6116A precision voltage source to +sense terminal of 6034A. Connect negative output terminals of 6116A to the -sense terminal of 6034A. Do not turn on 6116A.
- e. Connect DVM across sense terminals of 6034A.
- f. Turn off 6034A.
- g. Send string "P60V C1A M2 G" to 6034A. This sets output current to 1 A with a 60 V voltage limit. 6034A should be in CC (NORMAL) mode.
- h. Turn on 6116A. Adjust output of 6116 for 54.0075 V  $\pm 0.00$  on DVM.
- i. Run test program shown in Figure 5-52.
- j. Adjust A3R80 (REMOTE VOLTMETER FULL SCALE) so that reading displayed on controller is NV54.000 (or matches DVM reading if precision voltage source is not used).
- k. Turn off 6116A. Turn off 6034A. Disconnect test setup and reconnect strap between +sense and +output terminals of 6034A.

## Section VI REPLACEABLE PARTS

### 6-1 INTRODUCTION

6-2 This section contains information for ordering replacement parts. Table 6-4 lists parts in alpha-numeric order by reference designators and provides the following information:

- a. Reference Designators. Refer to Table 6-1.
- b. Hewlett-Packard Part Number.
- c. Total Quantity (TQ) used in that assembly (given the first time the particular part number appears).
- d. Description. Refer to Table 6-2 for abbreviations.
- e. Manufacturer's Federal Supply Code Number. Refer to Table 6-3 for manufacturer's name and address.
- f. Manufacturer's Part Number or Type.

6-3 Parts not identified by reference designator are listed at the end of Table 6-4 under Mechanical and/or Miscellaneous.

**Table 6-1. Reference Designators**

A	Assembly
B	Blower
C	Capacitor
CR	Diode
DS	Signaling Device (light)
F	Fuse
FL	Filter
G	Pulse Generator
J	Jack
K	Relay
L	Inductor
Q	Transistor
R	Resistor
RT	Thermistor Disc
S	Switch
T	Transformer
TB	Terminal Block
TS	Thermal Switch
U	Integrated Circuit
VR	Voltage Regulator (Zener diode)
W	Wire (Jumper)
X	Socket*
Y	Oscillator
Z	IC Resistance Network

\*Reference designator following "X" (e.g. XA2) indicates assembly or device mounted in socket.

### 6-4 ORDERING INFORMATION

6-5 To order a replacement part, address order or inquiry to your local Hewlett-Packard sales office (see lists at rear of this manual for addresses). Specify the following information for each part: Model, complete serial number, and any Option or special modification (J) numbers of the instrument; Hewlett-Packard part number; circuit reference designator; and description. To order a part not listed in Table 6-4, give a complete description of the part, its function, and its location.

**Table 6-2. Description Abbreviations**

ADDR	Addressable
ASSY	Assembly
AWG	American Wire Gauge
BUFF	Buffer
CER	Ceramic
COMP	Carbon Film Composition
CONV	Converter
DECODER/DEMULTI	Decoder/Demultiplexer
ELECT	Electrolytic
EPROM	Eraseable Programmable Read-Only Memory
FET	Field Effect Transistor
FF	Flip-Flop
FXD	Fixed
IC	Integrated Circuit
INP	Input
LED	Light Emmiting Diode
MET	Metalized
MOS	Metal-Oxide Silicon
OP AMP	Operational Amplifier
OPTO	Optical
OVP	Over Voltage Protection
PCB	Printed Circuit Board
PORC	Porcelain
POS	Positive
PRIOR	Priority
ROM	Read-Only Memory
RAM	Random Access Memory
RECT	Rectifier
REGIS	Register
RES	Resistor
TBAX	Tube Axial
TRIG	Triggered
UNI	Universal
VAR	Variable
VLTG REG	Voltage Regulator
WW	Wire Wound

Table 6-3. Code List of Manufacturers

Code	Manufacturer	Address
00853	Sangamo Electric Company	Pickens, Sc
01121	Allen Bradley Company	Milwaukee, WI
01295	Texas Instruments Inc, Semicon Comp Div.	Dallas, TX
03508	G.E. Company, Semicon Prod. Dept.	Auburn, N.Y.
04713	Motorola Semiconductor Products	Phoenix, AZ
07263	Fairchild Semiconductor Div.	Hicksville, N.Y.
14936	General Instruments Corp, Semicon Prod	Hicksville, N.Y.
16299	Corning Glass Works, Component Division	Raleigh, NC
19701	Mepco/Electra Corporation	Mineral Wells, TX
20940	Micro-Ohm Corporation	El Monte, CA
24546	Corning Glassworks	Bradford, PA
27014	National Semiconductor Corporation	Santa Clara, CA
27167	Corning Glassworks	Wilmington, NC
28480	Hewlett-Packard	Palo Alto, CA
32997	Bourns Inc.	Riverside, CA
55576	Synertek	Santa Clara, CA
56289	Sprague Electric Company	North Adams, MA
71400	Bussman Division of McGraw Edison Co.	St. Louis, MO
75042	TRW Inc, Philadelphia Division	Philadelphia, PA
82877	Rotron Inc	Woodstock, N.Y.
1B546	Varo Semiconductor Inc	Garland, TX
3L585	RCA Corporation, Solid State Div	Somerville, N.J.
H9027	Schurter AGH	Luzern, Switzerland
S0545	Nippon Electric Company	Tokyo, Japan

Table 6-4. Replaceable Parts List

Ref. Desig.	HP Part No.	TQ	Description	Mfr. Code	Mfr. Part No.
<b>A1</b>			<b>Power Mesh Assembly</b>		
C1	0160-4962	1	fxd porc 1 $\mu$ f 250 VAC	28480	
C2-5	0180-2968	4	fxd elect 590 $\mu$ f 200 V	28480	
C6, 7	0160-0269	2	fxd cer 0.1 $\mu$ f 500 V	28480	
C8, 9	0160-4960	2	fxd film 2200pf 1.6 kV	28480	
C10			Not Used		
C11	0160-3969	1	fxd porc. 0.015 $\mu$ f 250 VAC	28480	
C12, 13	0150-0012	6	fxd cer 0.01 $\mu$ f 1 kV	56289	C023A102J103MS38-CDH
C14			Not Used		
C15	0160-5022	1	fxd film 2200pf 1.6 kV	28480	
C16-18	0180-2971	3	fxd elect 1700 $\mu$ f 75 V	28480	
C19-20			Not Used		
C21	0160-4966	2	fxd met film 1 $\mu$ F 100 V	28480	
C22-25	0150-0012		fxd cer 0.01 $\mu$ f 1 k V	56289	C023A102J103MS38-CDH
C26	0160-4966		fxd met film 1 $\mu$ f 100 V	28480	
C27			Not Used		
C28	0160-0127	1	fxd cer 1 $\mu$ f 25 V	28480	
C29, 30			Not Used	Not Used	
C31	0160-0938	1	fxd mica 1000pf 100 V 5%	28480	
C32, 33			Not Used		
C34	0180-0155	1	fxd elect 2.2 $\mu$ f 20 V	56289	150D225X0020A2
C35	0180-0693	1	fxd elect 1000 $\mu$ f 25 V	54473	ECE-A25V1000
C36, 37	0180-2628	2	fxd elect 220 $\mu$ f 50 V	28480	
C38			Not Used		
C39	0180-0500	1	fxd elect 330 $\mu$ f 25 V	28480	
C40	0180-1954	1	fxd elect 4.7 $\mu$ f 6 V	56289	150D475X5006A2
C41			Not Used		
C42	0160-4722	1	fxd cer 0.1 $\mu$ f 50 V	28480	
CR1-4	1901-0759	4	diode 3 A 600 V	14936	IN5406
CR5, 6	1901-1087	2	power rect 3 A 600 V	04713	MR856
CR7, 8	1901-1065	2	power rect 1 A 400 V	14936	IN4936
CR 9, 10			Not Used		
† CR11, 12	1901-0050	9	diode switching 200 mA 80 V	28480	
CR13	1901-0888	1	power rect 30 A 300 V	28480	
CR14	1901-0496	1	power rect 12 A 100 V	04713	MR1121
CR15, 16	1901-0050		diode switching 200 mA 80 V	28480	
CR17-20			Not Used		
CR21	1901-0050		diode switching 200 mA 80 V	28480	
CR22, 23	1901-0327	2	power rect 1 A 200 V	03508	A14B
CR24-27	1901-0050		diode switching 200 mA 80 V	28480	
CR28-30	1901-0033	3	diode 200 mA 180 V	28480	
F1			Not Used		
F2	2110-0094	1	fuse 1.25 A 250 V	28480	
L1, 2			choke assy, consists of:		
	9170-0721	2	core, magnetic	28480	
	06024-80094	2	coil	28480	
L3	06024-80096	1	inductor 3 A	28480	

†These components should all be replaced together; service kit contains all components.

Table 6-4. Replaceable Parts List (cont.)

Ref. Desig.	HP Part No.	TQ	Description	Mfr. Code	Mfr. Part No.
L4, 5		2	Not Used		
L6	06024-80097	1	inductor 12 A	28480	
L7			choke assy 3 $\mu$ H, consists of:		
	9170-0707	1	ferrite core	28480	
	06024-80095	1	coil	28480	
L8, 9			Not Used		
L10	9170-1134	1	magnetic core	28480	
† Q1, 2	5080-2017	2	FET	28480	
† Q3, 4	1854-0477	3	NPN Si	04713	2N2222A
Q5	1854-0755	1	NPN Si	3L585	2N6254
Q6	1854-0644	1	NPN Si	3L585	29C
Q7, 8			Not Used		
Q9	1854-0823	1	NPN Si	28480	
Q10	1854-0585	1	NPN Si	04713	MJE182
Q11	1854-0477		NPN Si	04713	2N2222A
Q12	1854-0215	1	NPN Si	04713	2N3904
R1	0757-0433	1	fxd film 3.32 k 1% 1/8 W	24546	C4-1/8-TO-3321-F
R2	0683-1035	3	fxd comp 10 k 5% 1/4 W	01121	CB-1035
R3	0757-0438	1	fxd film 5.11 k 1% 1/8 W	24546	C4-1/8-TO-5111-F
R4			Not Used		
R5, 6	0811-1867	2	fxd ww 15 k 5% 5 W	28480	
R7, 8	0698-3547	2	fxd comp 1 5% 1/2 W	01121	EB-10G5
R9, 10			Not Used		
R11	0698-3601	2	fxd film 10 $\Omega$ 5%	27167	FP42-2-TOO-10RO-J
R12	0811-1857	2	fxd ww 400 $\Omega$ 5% 5 W	28480	
R13	0683-1055	3	fxd comp 1M 5% 1/4 W	01121	CB-1055
† R14	0698-3378	2	fxd comp 51 $\Omega$ 5% 1/8 W	01121	BB-5105
R15	0683-3915	2	fxd comp 390 $\Omega$ 5% 1/4 W	01121	CB-3915
† R16	0683-1015	2	fxd comp 100 $\Omega$ 5% 1/4 W	01121	CB-1015
R17			Not Used		
R18	0698-3601		fxd film 10 $\Omega$ 5%	27167	FP42-2-TOO-10RO-J
R19	0811-1857		fxd ww 400 $\Omega$ 5% 5 W	28480	
R20	0683-1055		fxd comp 1M 5% 1/4 W	01121	CB-1055
† R21	0698-3378		fxd comp 51 $\Omega$ 5% 1/8 W	01121	BB-5105
R22	0683-3915		fxd com p 390 $\Omega$ 5% 1/4 W	01121	CB-3915
† R23	0683-1015		fxd comp 100 $\Omega$ 5% 1/4 W	01121	CB-1015
R24-26			Not Used		
R27	0698-3628	1	fxd film 220 $\Omega$ 5% 2W	28480	
R28, 29	0811-1094	2	fxd ww 0.4 $\Omega$ 5%	28480	
R30	0698-3225	1	fxd film 1.43 k 1% 1/8 W	24546	C4-1/8-TO-1431-F
R31	0811-1865	1	fxd ww 2 k 1% 5 W	28480	
R32	0689-6225	1	fxd film 6.2 k 5% 1 W	28480	
R33	0683-1025	3	fxd comp 1 k 5% 1/4 W	01121	CB-1025
R34	0698-0084	1	fxd film 2.15 k 1% 1/4 W	24546	C4-1/8-TO-2151-F
R35	0812-0019	1	fxd ww 0.33 5% 3 W	28480	
R36	0757-0391	1	fxd film 39.2 1% 1/8 W	24546	C4-1/8-TO-39R2-F



Table 6-4. Replaceable Parts List (cont.)

Ref. Desig.	HP Part No.	TQ	Description	Mfr. Code	Mfr. Part No.
R37	0683-1025		fxd comp 1k 5% 1/4 W	01121	CB-1025
R38	0683-2725	1	fxd comp 2.7 k 5% 1/4 W	01121	CB-2725
R39	0757-0442	3	fxd film 10 k 1% 1/8 W	24546	C4-1/8-TO-1002-F
R40	0683-1025		fxd comp 1 k 5% 1/4 W	01121	CB-1025
R41			Not Used		
R42	0757-0442		fxd film 10 k 1% 1/8 W	24546	C4-1/8-TO-1002-F
R43	0757-0459	1	fxd film 56.2 k 1% 1/8 W	24546	C4-1/8-TO-5622-F
R44	0757-0317	1	fxd film 1.33 k 1% 1/8 W	24546	C4-1/8-TO-1331-F
R45			Not Used		
R46	0757-0472	1	fxd film 200 k 1% 1/8 W	24546	C4-1/8-TO-2003-F
R47	0698-6342	1	fxd film 90 k 0.1% 1/8W	28480	
R48			Not Used		
R49	0757-0123	1	fxd film 34.8 k 1% 1/8 W	28480	
R50	0698-3496	1	fxd film 3.57 k 1% 1/8 W	24546	C4-1/8-TO-3571-F
R51	0698-4157	1	fxd film 10 k 0.1% 1/8 W	28480	
R52			Not Used		
R53	0757-0288	1	fxd film 9.09k 1% 1/8 W	19701	MF4C1/8-TO-9091-F
R54			Not Used		
R55, 56	0683-1035		fxd comp 10 k 5% 1/4 W	01121	CB-1035
R57			Not Used		
R58	0698-3151	1	fxd film 2.87 k 1% 1/8 W	28480	
R59, 60			Not Used		
R61	0686-4715	1	fxd comp 470 $\Omega$ 5% 1/2 W	01121	EB-4715
R62	0683-3305	1	fxd comp 33 $\Omega$ 5% 1/4 W	01121	CB-3305
R63, 163, 263	0683-0275	3	fxd comp 2.7 $\Omega$ 5% 1/4 W	01121	CB-0275
R64	0683-1055	1	fxd comp 1M 5% 1/4 W	01121	CB-1055
R65	0757-0442		fxd film 10 k 1% 1/8 W	24546	C4-1/8-TO-1002-F
R66	0683-5150	1	fxd comp 51 $\Omega$ 5% 1/4 W	01121	CB-5105
R67, 68	0698-4132	2	fxd comp 62 $\Omega$ 1% 1/8W	28480	
RT1, 2	0839-0006	2	thermistor disc 10%	28480	
S1			Not Used		
S2	3101-1914		switch, slide, 2-DPDT	28480	
T1	06024-80090	1	power transformer	28480	
T2	5080-1937	1	current limit transformer	28480	
T3, 4	5080-2018	2	driver transformer	28480	
T5	06024-80091	1	bias transformer	28480	
TB1	0360-1903	1	barrier block, 7 term	28480	
TS1	3103-0017	1	thermal switch + 193 $^{\circ}$ F	28480	
U1	1826-0161	1	IC, op amp quad	04713	MLM324P
U2, U12	1820-1050	2	IC, driver nor dual 2 inp	01295	SN75454BP
U3, 4	1906-0006	2	full wave bridge rect 1A 400 V	1B546	VE48
U5	1826-0346	1	IC, op amp dual	27014	LM358N
VR1	1902-0575	2	zener 6.5 V 2%	28480	
VR2	1902-3002	1	zener 2.37 V 5%	28480	
VR3	1902-0057	1	zener 6.49 V 5%	28480	
VR4	1902-0575		zener 6.5 V 2%	28480	

Table 6-4. Replaceable Parts List (cont.)

Ref. Desig.	HP Part No.	TQ	Description	Mfr. Code	Mfr. Part No.
VR5	1902-3180	1	zener 11.8 V 2%	28480	
VR6	1902-0064	1	zener 7.5 V 5%	28480	
W1	8150-2943		wire 18 AWG, 1 inch	28480	
XA1			Not Used		
XA2	1251-1886	1	PCB edge connector	28480	
<b>A1 Power Mesh Assembly-Mechanical and Miscellaneous</b>					
	0340-0170	1	Insulated bushing for CR14	28480	
	0340-0171	1	Insulated bushing for CR13	28480	
	0340-0174	2	Insulator for Q1, 2	28480	
	0340-0503	2	Insulator for Q1, 2	28480	
	0340-0784	1	Insulated bushing for T1	28480	
	0360-1843	8	Single stud terminal for RT1, 2, R14, 21	28480	
	0360-1979	6	Terminal stud for Q1, 2, 5	28480	
	1205-0282	1	Heatsink for Q6	28480	
	1251-0600	1	Contact connector	28480	
	2110-0269	2	Fuseholder clips for F2	28480	
	06024-00009	2	FET heatsink for Q1, 2	28480	
	06024-00010	1	Heatsink for CR13, 14, Q5	28480	
	60034-60003	1	Cable assembly	28480	
	06034-80001	1	Heat dissipator	28480	
	0362-0265	2	Single-contact connector for fan	28480	
<b>A2 Control Board Assembly</b>					
C1, 2	0180-0291	3	fxd elect 1 $\mu$ f 35 V	56289	150D105X9035A2
C3, 4	0160-1074	2	fxd cer 0.47 $\mu$ f 25 V	28480	
C5	0160-2215	1	fxd mica 750pf 300 V 5%	28480	
C6	0140-0200	1	fxd mica 390pf 300 V 5%	28480	
C7	0160-4722	5	fxd cer 0.1 $\mu$ f 50 V	28480	
C8			Not Used		
C9, 10	0160-3070	2	fxd mica 100pf 300 V 5%	28480	
C11	0180-0291		fxd elect 1 $\mu$ f 35 V	56289	150D105X0935A2
C12, 13	0140-0199	4	fxd mica 240pf 300 V 5%	28480	
C14-16	0160-4722		fxd cer 0.1 $\mu$ f 50 V	28480	
C17	0140-0199		fxd mica 240 pf 300 V 5%	28480	
C18	0160-0159	2	fxd film 6800pf 200 V	28480	
C19	0160-0153	1	fxd film 1000pf 200 V	28480	
C20	0170-0040	1	fxd film 0.047 $\mu$ f 200 V	28480	
C21	0160-0159		fxd film 6800pf 200 V	28480	
C22	0140-0203	1	fxd mica 30 pf 500 V 5%	28480	
C23	0160-5377	1	fxd film 2.2 $\mu$ f 6.3 V	28490	
C24	0160-0127	1	fxd cer 1 $\mu$ f 25 V	28480	
C25	1060-4741	1	fxd cer 0.22 $\mu$ f 50 V	28480	
C26	0160-4557	3	fxd cer 0.1 $\mu$ f 50 V	16299	CAC04X7R104M050A
C27	0160-0154	1	fxd film 2200pf 200 V	28480	
C28	0180-3056	1	fxd elect 390 $\mu$ f 20 V	28480	
C29	0160-4722		fxd cer 0.1 $\mu$ f 50 V	28480	

Table 6-4. Replaceable Parts List (cont.)

Ref. Desig.	HP Part No.	TQ	Description	Mfr. Code	Mfr. Part No.	
C30	0160-3490	2	fxd cer 1 $\mu$ f 50 V	28480	CAC04XR104M050A	
C31,32	0160-4557		fxd cer 0.1 $\mu$ f 50 V	16299		
C33	0160-0162	1	fxd film 0.022 $\mu$ f 200 V	28480		
C34	0160-3490		fxd cer 1 $\mu$ f 50 V	28480		
C35	0140-0199		fxd mica 240pf 300 V 5%	28480		
C36	0160-0161	1	fxd film 0.01 $\mu$ f 200 V	28480		
CR1	1901-0050	10	diode switching 200 mA 80 V	28480		
CR2-4			Not Used			
CR5, 6	1901-0050		diode switching 200 mA 80 V	28480		
CR7-10	1901-0033	8	diode 200 mA 180 V	28480		
CR11-14			Not Used			
CR15	1901-0033		diode 200 mA 180 V	28480		
CR16, 17			Not Used			
CR18-20	1901-0050		diode switching 200 mA 80 V	28840		
CR21-22			Not Used			
CR23	1901-0050		diode switching 200 mA 80 V	28480		
CR24	1901-0033		diode 200 mA 180 V	28480		
CR25-27	1901-0050		diode switching 200 mA 80 V	28480		
CR28, 29			Not Used			
CR30, 31	1901-0033		diode 200 mA 180 V	28480		
J1	1200-0507	1	16 contact IC socket	28480		
Q1	1854-0448	1	NPN Si	28480		
Q2	1853-0041	1	PNP Si	28480		
Q3			Not Used			
Q4-8	1854-0823	6	NPN Si	28480		
Q9-13			Not Used			
Q14	1854-0823		NPN Si	28480		
R1	0683-2025	1	fxd comp 2 k 5% 1/4 W	01121		CB-2025
R2	0757-0436	1	fxd film 4.32 k 1% 1/8 W	24546		C4-1/8-TO-4321-F
R3	0698-4435	1	fxd film 2.49k k 1% 1/8 W	24546		C4-1/8-TO-2491-F
R4	0757-0290	1	fxd film 6.19 k 1% 1/8 W	19701		MF4C1/8-TO-6191-F
R5	0698-4196	1	fxd film 1.07 k 1% 1/8 W	24546		C4-1/8-TO-1071-F
R6, 7			Not Used	Not Used		
R8	0757-0440	1	fxd film 7.5 k 1% 1/8 W	24546		C4-1/8-TO-7501-F
R9	0698-4484	1	fxd film 19.1 k 1% 1/8 W	24546		C4-1/8-TO-1912-F
R10	0757-0446	1	fxd film 15 k 1% 1/8 W	24546		C4-1/8-TO-1502-F
R11	0698-4470	1	fxd film 6.98 k 1% 1/8 W	24546	C4-1/8-TO-6981-F	
R12-14			Not Used			
R15	0757-0442	4	fxd film 10 k 1% 1/8 W	24546	C4-1/8-TO-1002-F	
R16	0757-0416	1	fxd film 511 $\Omega$ 1% 1/8 W	24546	C4-1/8-TO-511R-F	
R17	0698-3449	1	fxd film 28.7 k 1% 1/8 W	24546	C4-1/8-TO-2872-F	
R18	0698-0084	8	fxd film 2.15 k 1% 1/8 W	24546	C4-1/8-TO-2151-F	
R19	0757-0449	4	fxd film 20 k 1% 1/8	24546	C4-1/8-TO-2002-F	
R20	0757-0442		fxd film 10 k 1% 1/8 W	24546	C4-1/8-TO-1002-F	
R21	0757-0449		fxd film 20 k 1% 1/8 W	24546	C4-1/8-TO-2002-F	
R22			Not Used			

Table 6-4. Replaceable Parts List (cont.)

Ref. Desig.	HP Part No.	TQ	Description	Mfr. Code	Mfr. Part No.
R23, 24	0698-0084		fxd film 2.15 k 1% 1/8 W	24546	C4-1/8-TO-2151-F
R25	0757-0413	1	fxd film 392 $\Omega$ 1% 1/8 W	24546	C4-1/8-TO-392R-F
R26, 27	0757-0433	3	fxd film 3.32 k 1% 1/8 W	24546	C4-1/8-TO-3321-F
R28	0757-0427	1	fxd film 1.5 k 1% 1/8 W	24546	C4-1/8-TO-1501-F
R29	0698-0084		fxd film 2.15 k 1% 1/8 W	24546	C4-1/8-TO-2151-F
R30, 31			Not Used		
R32, 33	0757-0451		fxd film 24.3 k 1% 1/8 W	24546	C4-1/8-TO-2432-F
R34	0698-0084		fxd film 2.15 k 1% 1/8 W	24546	C4-1/8-TO-2151-F
R35	0683-1055	2	fxd comp 1 M 5% 1/4 W	01121	CB-1055
R36	0683-3335	1	fxd comp 33 k 5% 1/4 W	01121	CB-3335
R37-39			Not Used		
R40	0698-3498	1	fxd film 8.66 1% 1/8 W	24546	C4-1/8-TO-8661-F
R41, 42			Not Used		
R43	0683-2225	1	fxd comp 2.2 k 1% 1/8 W	24546	C4-1/8-TO-2201-F
R44	0683-1045	3	fxd comp 100 k 5% 1/4 W	01121	CB-1045
R45, 46	0683-4725	2	fxd comp 4.7 k 5% 1/4 W	01121	CB-4725
R47	0757-0418	1	fxd film 619 $\Omega$ 1% 1/8 W	24546	C4-1/8-TO-619R-F
R48			Not Used		
R49	0698-0084		fxd film 2.15 k 1% 1/8 W	24546	C4-1/8-TO-2151-F
R50	0757-0442		fxd film 10 k 1% 1/8 W	24546	C4-1/8-TO-1002-F
R51	0757-0424	1	fxd film 1.1 k 1% 1/8 W	24546	C4-1/8-TO-1101-F
R52	0757-0280	2	fxd film 1 k 1% 1/8 W	24546	C4-1/8-TO-1001-F
R53	0757-0447	2	fxd film 16.2 k 1% 1/8 W	24546	C4-1/8-TO-1622-F
R54	2100-3351	1	var res 500 $\Omega$ 5%	28480	
R55	0757-0270	2	fxd film 249 k 1% 1/8 W	24546	C4-1/8-TO-2493-F
R56	0757-0473	1	fxd film 221 k 1% 1/8 W	24546	C4-1/8-TO-2213-F
R57			Not Used		
R58	0698-4536	1	fxd film 340 k 1% 1/8 W	28480	
R59	0683-6835	1	fxd comp 68 k 5% 1/4 W	01121	CB-6835
R60	0757-0461	1	fxd film 68.1 k 1% 1/8 W	24546	C4-1/8-TO-6812-F
R61	0683-1045		fxd comp 100 k 5% 1/4 W	01121	CB-1045
R62	0757-0270		fxd film 249 k 1% 1/8 W	24546	C4-1/8-TO-2493-F
R63	0683-1065	1	fxd comp 10 M 5% 1/4 W	01121	CB-1065
R64	0698-5094	1	fxd film 5.1 M 5% 1/4 W	01121	CB-5155
R65	2100-3353	1	var res 20 k 10%	28480	C4-1/8-TO-2002-F
R66	0757-0278	2	fxd film 1.78 k 1% 1/8 W	28480	C4-1/8-TO-1781-F
R67	0757-0447		fxd film 16.2 k 1% 1/8 W	24546	C4-1/8-TO-1622-F
R68			Not Used		
R69	0757-0449		fxd film 20k 1% 1/8 W	24546	C4-1/8-TO-2002-F
R70	0698-7497	1	fxd film 100 k 0.1% 1/8 W	19701	MF4C1/8-T-1003-B
R71	0698-6343	1	fxd film 9 k 0.1% 1/8 W	24546	C4-1/8-TO-9001-F
R72	0757-0400	1	fxd film 90.9 $\Omega$ 1% 1/8 W	24546	C4-1/8-TO-90R9-F
R73	0686-6225	1	fxd comp 6.2 k 5% 1/2 W	01121	EB-6225
R74-76			Not Used		
R77, 78	0686-1035	2	fxd comp 10 k 5% 1/2 W	01121	EB-1035
R79	0683-1055		fxd comp 1 M 5% 1/4 W	01121	CB-1055

Table 6-4. Replaceable Parts List (cont.)

Ref. Desig.	HP Part No.	TQ	Description	Mfr. Code	Mfr. Part No.
R80	0757-0458	2	fxd film 51.1 k 1% 1/8 W	24546	C4-1/8-TO-5112-F
R81	0757-0442		fxd film 10 k 1% 1/8 W	24546	C4-1/8-TO-1002-F
R82	0683-1645	1	fxd comp 160 k 5% 1/4 W	01121	CB-1645
R83, 85		2	Jumpers	28480	
R84, 86,87			Not Used		
R83-88			Not Used		
R89	0757-0280		fxd film 1 k 1% 1/8 W	24546	C4-1/8-TO-1001-F
R90	0757-0344	3	fxd film 1 M 1% 1/4 W	24546	C5-1/8-TO-1004-F
R91	2100-3970	1	var res	28480	
R92	2100-3969	1	var res	28480	
R93	0698-6341	1	fxd film 750Ω 1% 1/8 W	28480	
R94	0698-3274	1	fxd film 10 k 1% 1/8 W	28480	
R95	0757-0344		fxd film 1 M 1% 1/4 W	24546	C5-1/8-TO-1004-F
R96	0757-0433		fxd film 3.32 k 1% 18 W	24546	C4-1/8-TO-3321-F
R97	0757-0344		fxd film 1 M 1% 1/4 W	24546	C4-1/8-TO-1004-F
R98, 99			Not Used		
R100	0683-5105	1	fxd comp 51Ω 5% 1/4 W	01121	CB-5105
R101	0683-0275	1	fxd comp 2.7Ω 5% 1/4 W	01121	CB-0275
R102	0757-0438	3	fxd film 5.11 k 1% 1/8 W	24546	C4-1/8-TO-5111-F
R103-107			Not Used		
R108	0698-4121	1	fxd film 11.3 k 1% 1/8 W	24546	C4-1/8-TO-1132-F
R109			Not Used		
R110	0757-0436		fxd film 4.32 k 1% 1/8 W	24546	C4-1/8-TO-4321-F
R111	0698-4014	1	fxd film 787Ω 1% 1/8 W	24546	C4-1/8-TO-787R-F
R112	0757-0458		fxd film 51.1 k 1% 1/8 W	24546	C4-1/8-TO-5112-F
R113, 114	0698-0084		fxd film 2.15 k 1% 1/8 W	24546	C4-1/8-TO-2151-F
R115, 116			Not Used		
R117	0757-0449		fxd film 20 k 1% 1/8 W	24546	C4-1/8-TO-2002-F
R118	0698-3430	1	fxd film 21.5Ω 1% 1/8 W	24546	C4-1/8-TO-2152-F
R119			Not Used		
R120	0757-0438		fxd film 5.11 k 1% 1/8 W	24546	C4-1/8-TO-5111-F
R121	0757-0421		fxd film 825Ω 1% 1/8 W	24546	C4-1/8-TO-825R-F
R122	0757-0282	1	fxd film 221Ω 1% 1/8 W	24546	C4-1/8-TO-221R-F
R123	0757-0438		fxd film 5.11 k 1% 1/8 W	24546	C4-1/8-TO-5111-F
R124	0683-1045		fxd comp 100 k 5% 1/4 W	01121	CB-1045
R125			Not Used		
R126	0757-0278		fxd film 1.78 k 1% 1/8 W	24546	
U1	1826-0144	1	IC, vltg reg, +5 V	04713	MC7805CP
U2, 3	1820-0493	2	IC, op amp	27014	LM307N
U4	1826-0138	1	IC, comparator quad	01295	LM339N
U5	1820-1443	1	IC, counter bin	01295	SN74LS293N
U6	1826-0065	2	IC, comparator	S0545	UPC311C
U7	1820-1203	1	IC, tri 3-inp pos-and gate	01295	SN74LS11N
U8	1820-1209	1	IC, quad 2 inp pos-nand buff op coll out	01295	SN74LS38N
U9	1820-1112	1	IC, dual D-type pos-edge trig FF	01295	SN74LS74AN
U10	1820-1437	1	IC, dual monos multiv	01295	SN74LS221N
U11	1826-0524	1	IC, op amp quad	27014	LM324AN

Table 6-4. Replaceable Parts List (cont.)

Ref. Desig.	HP Part No.	TQ	Description	Mfr. Code	Mfr. Part No.
U12	1826-0065		IC, comparator	S0 545	UPC311C
U13	1820-0477	1	IC, op amp	S0 545	UPC301AC
U14	1826-0161	1	IC, op amp quad	04713	MLM324P
VR1	1902-0777	1	zener 6.2 V 5%	04713	IN825
VR2	1902-0575	1	zener 6.5 V 2%	28480	
VR3	1902-0057		zener 6.49 V 5%	28480	
Y1	0960-0586	1	ceramic resonator	28480	
Z1	1810-0231	1	res. network	01121	208A222
Z2	1810-0279	1	res. network	01121	210A472
<b>A2 Control Board Assembly-Mechanical and Miscellaneous</b>					
	1200-0181	2	Insulator for Q1, 2	28480	
	1205-0282	1	Heatsink for U1	28480	
	0590-0199	1	Hex nut with lockwasher for U1	28480	
<b>A3</b>			<b>Front Panel Assembly</b>		
C1	0140-0190	2	fxd mica 39pf 300 V 5%	28480	
C2, 3	0160-4722	15	fxd cer 0.1 $\mu$ f 50 V	28480	
C4-6	0160-4761	16	fxd cer 0.01 $\mu$ f 100 V	28480	
C7	0180-0032	1	fxd elect 10 $\mu$ f 12 V	56289	30D106G012BA2
C8	0160-4761		fxd cer 0.01 $\mu$ f 100 V	28480	
C9	0180-0059	3	fxd elect 10 $\mu$ f 25 V	56289	30D106G025BB2
C10	0160-4761		fxd cer 0.01 $\mu$ f 100 V	28480	
C11	0180-0059		fxd elect 10 $\mu$ f 25 V	56289	30D106G025BB2
C12, 13	0170-0040	2	fxd film 0.047 $\mu$ f 200 V	28480	
C14, 15	0160-0166	2	fxd film 0.068 $\mu$ f 200 V	28480	
C16			Not Used		
C17-19	0160-4722		fxd cer 0.1 $\mu$ f 50 V	28480	
C20			Not Used		
C21-23	0160-4722		fxd cer 0.1 $\mu$ f 50 V	28480	
C24			Not Used		
C25	0160-4722		fxd cer 0.1 $\mu$ f 50 V	28480	
C26	0160-4801	2	fxd cer 100pf 100 V 5%	28480	
C27	0160-4722		fxd cer 0.1 $\mu$ f 50 V	28480	
C28, 29	0160-4761		fxd cer 0.01 $\mu$ f 100 V	28480	
C30, 31	0160-4722		fxd cer 0.1 $\mu$ f 50 V	28480	
C32	0160-5101	2	fxd met film 1 $\mu$ f 63 V	28480	
C33	0160-4722		fxd cer 0.1 $\mu$ f 50 V	28480	
C34	0160-4801		fxd cer 100pF 10 V 5%	28480	
C35, 36	0160-4761		fxd cer 0.01 $\mu$ f 100 V	28480	
C37	0160-0174	1	fxd cer 0.47 $\mu$ f 25 V	28480	
C38	0160-4761		fxd cer 0.01 $\mu$ f 100 V	28480	
C39, 40	0160-4722		fxd cer 0.1 $\mu$ f 50 V	28480	
C41	0140-0190		fxd mica 39pf 300 V 5%	28480	
C42	0160-4761		fxd cer 0.01 $\mu$ f 100 V	28480	
C43	0180-0059		fxd elect 10 $\mu$ f 25 V	56289	30D106G025BB2
C44-48	0160-4761		fxd cer 0.01 $\mu$ f 100 V	28480	
C49	0160-5101		fxd met film 1 $\mu$ f 63 V	28480	

Table 6-4. Replaceable Parts List (cont.)

Ref. Desig.	HP Part No.	TQ	Description	Mfr. Code	Mfr. Part No.
CR1, 2	1901-0461	3	diode 200 mA 10 V	28480	
CR3	1901-0033	4	diode 200 mA 180 V	28480	
CR4	1901-0461		diode 200 mA 10 V	28480	
CR5, 6			Not Used		
CR7, 8	1901-0376	2	diode 50 mA 35 V	28480	
CR9, 10	1901-0033		diode 200mA 180 V	28480	
CR11			Not Used		
CR12	1901-0033		diode 200 mA 180 V	28480	
DS1	1990-0681	2	display, single digit, $\pm$	28480	5082-7656
DS2-4	1990-0540	6	7-segment display	28480	5082-7650
DS5	1990-0681		display, single digit, $\pm$	28480	5082-7656
DS6-8	1990-0540		7-segment display	28480	5082-7650
DS9	1990-0772	1	LED	28480	HLMP-2655
DS10-25	1990-0831	16	LED	28480	
G1	06034-60006	1	rotary pulse generator assembly	28480	
J1 A&B	06034-60004	1	J1 Cable Assembly	28480	
J2	06034-60005	1	J2 Cable Assembly	28480	
J3, 4	1251-7217	2	connector	28480	
J5	1251-7690				
K1	0490-1013	1	relay	28480	
L1	9100-1618	1	coil 5.6 $\mu$ H 10%	28480	
Q1, 2	1853-0281	2	PNP Si	04713	2N2907A
Q3	1853-0036	1	PNP Si	28480	
Q4	1853-0099	1	PNP Si	28480	
Q5-8	1854-0823	4	NPN Si	28480	
R1	0757-0465	3	fxd film 100 k 1% 1/8 W	24546	C4-1/8-TO-1003-F
R2	0698-6351	2	fxd film 133 k 1% 1/8 W	28480	
R3	2100-3214	3	var res 100 k	28480	
R4	2100-3659	2	var res 20 k 10%	32997	3292W-1-203
R5	0698-7845	2	fxd film 21.5 k 1% 1/8 W	19701	MF4C1/8-T9-2152-F
R6	0698-6351		fxd film 133 k 1% 1/8 W	28480	
R7	2100-3097	2	var res. 100 k 10%	32997	3292W-1-104
R8	2100-3659		var res. 20 k 10%	32997	3292W-1-203
R9	0698-7845		fxd film 21.5 k 1% 1/8 W	19701	MF4C1/8-T9-2152-F
R10	0698-6342	2	fxd film 90 k 1% 1/8 W	28480	
R11	0811-3154	1	fxd ww 9 k 0.05%	20940	114-1/32-9001-A
R12	0811-3198	1	fxd ww 1 k 0.05%	28480	
R13-16			Not Used		
R17	0683- 8205	1	fxd comp 82 $\Omega$ 5% 1/4 W	01121	CB-8205
R18	0686-7515	1	fxd comp 750 $\Omega$ 5% 1/2 W	01121	EB-7515
R19	0698-4157	1	fxd film 10 k 0.1% 1/8 W	28480	
R20	0698-6342		fxd film 90 k 1% 1/8 W	28480	
R21	0698-5558	1	fxd film 25 k 1% 1/8 W	28480	
R22	0698-7961	1	fxd film 80.6 k 1% 1/8 W	24546	C4-1/8-TO-8062-F
R23	0683-4315	3	fxd comp 430 $\Omega$ 5% 1/4 W	01121	CB-4315
R24	0683-1035	3	fxd comp 10 k 5% 1/4 W	01121	CB-1035
R25	0683-3935	3	fxd comp 39 k 5% 1/4 W	01121	CB-3935
R26	0757-0439	1	fxd film 6.81 k 1% 1/8 W	24546	C4-1/8-TO-6811-F

Table 6-4. Replaceable Parts List (cont.)

Ref. Desig.	HP Part No.	TQ	Description	Mfr. Code	Mfr. Part No.
R27	0698-6960	1	fxd film 27 k 1% 1/8 W	28480	
R28	0683-3935		fxd comp 39 k 5% 1/4 W	01121	CB-3935
R29	0698-4500	1	fxd film 57.6 k 1% 1/8 W	24546	C4-1/8-TO-5762-F
R30	0757-0433	1	fxd film 3.32 k 1% 1/8 W	24546	C4-1/8-TO-3321-F
R31	0698-5449	1	fxd film 5 k 0.1% 1/8 W	19701	MF4C-1/8-T2-5001-B
R32	0698-6863	1	fxd film 1.537 k 0.25% 1/8 W	28480	
R33, 34	0683-4315		fxd comp 430 $\Omega$ 5% 1/4 W	01121	CB-4315
R35	0683-1015	3	fxd comp 100 $\Omega$ 5% 1/4 W	01121	CB-1015
R36, 37	0757-0481	2	fxd film 475 k 1% 1/8 W	19701	MF4C1/8-TO-4753-F
R38	0757-0270	1	fxd film 249 k 1% 1/8 W	24546	C4-1/8-TO-2493
R39	0683-6225	1	fxd comp 6.2 k 5% 1/4 W	01121	CB-6225
R40	0683-3625	1	fxd comp 3.6 k 5% 1/4 W	01121	CB-3625
R41	0698-0085	1	fxd film 2.61 k 1% 1/8 W	24546	C4-1/8-TO-2611-F
R42	2100-3211	1	var res 1 k 10%	28480	
R43	2100-1775	1	var res 5 k 5%	32997	3292W-1-502
R44	0683-3935		fxd comp 39 k 5% 1/4 W	01121	CB-3935
R45, 46	0683-1035		fxd comp 10 k 5% 1/4 W	01121	CB-1035
R47	0757-0344	4	fxd film 1M 1% 1/4 W	24546	C5-1/8-TO-1004-F
R48, 49	0683-1055	2	fxd comp 1M 5% 1/4 W	01121	CB-1005
R50, 51	0757-0344		fxd film 1M 1% 1/4 W	24546	C5-1/8-TO-1004-F
R52	0757-0289	1	fxd film 13.3 k 1% 1/8 W	19701	MF4C1/8-TO-1332-F
R53	0698-8751	1	fxd film 14.7 k 5% 1/8 W	28480	
R54	0683-2225	3	fxd comp 2.2 k 5% 1/4 W	01121	CB-2225
R55, 56	0757-0395	2	fxd film 56.2 k 1% 1/8 W	24546	C4-1/8-TO-5622-F
R57	0757-0934	1	fxd film 2.7 k 2% 1/8 W	24546	C4-1/8-TO-2701-F
R58	0698-6318		fxd film 1.5 K 1% 1/8 W	28480	
R59	0757-0442	6	fxd film 10 k 1% 1/8 W	24546	C4-1/8-TO-1002-F
R60	0698-4121	1	fxd film 11.3 k 1% 1/8 W	24546	C4-1/8-TO-1132-F
R61-70	0683-3015	15	fxd comp 300 $\Omega$ 5% 1/4 W	01121	CB-3015
R71	0698-7082	1	fxd film 100 k 1% 1/8 W	28480	
R72	0698-3226	1	fxd film 6.49 k 1% 1/8 W	24546	C4-1/8-TO-6491-F
R73	0698-8184	1	fxd film 7.5 k 1% 1/8 W	19701	MF4C1/8-T9-7501-F
R74	0698-3493	2	fxd film 4.12 k 1% 1/8 W	24546	C4-1/8-TO-4121-F
R75	0683-3015		fxd comp 300 $\Omega$ 5% 1/4 W	01121	CB-3015
R76	0683-5115	1	fxd comp 510 $\Omega$ 5% 1/4 W	01121	CB-5115
R77	0698-3493		fxd film 4.12k 1% 1/8 W	24546	C4-1/8-TO-4121-F
R78	2100-3089	2	var res 5 k 10%	32997	3292W-1-502
R79	0699-0236	1	fxd film 2.5 k 1% 1/8 W	28480	
R80	2100-3089		var res 5 k 10%	32997	3292W-1-502
R81, 82	2100-3214		var res 100 k 10%	28480	
R83-86	0757-0467	4	fxd film 121 k 1% 1/8 W	24546	C4-1/8-TO-1213-F
R87, 88	0757-0278	2	fxd film 1.78 k 1% 1/8 W	28480	
R89, 90	2100-3210	2	var res 10 k 10%	28480	
R91	0757-0200	2	fxd film 5.62 k 1% 1/8 W	24546	C4-1/8-TO-5621-F
R92, 93	0683-2735	2	fxd comp 27 k 5% 1/4 W	01121	CB-2735
R94	0757-0465		fxd film 100 k 1% 1/8 W	24546	C4-1/8-TO-1003-F
R95	0757-0344		fxd film 1 M 1% 1/4 W	24546	C4-1/8-TO-1004-F
R96	2100-3097		var res 100 k 10%	32997	3292W-1-104



Table 6-4. Replaceable Parts List (cont.)

Ref. Desig.	HP Part No.	TQ	Description	Mfr. Code	Mfr. Part No.
R97-99	0683-3015		fxd comp 300Ω 5% 1/4 W	01121	CB-3015
R100-120, 122-142	0683-2015	44	fxd comp 200Ω 5% 1/4 W	01121	CB-2015
R121, 145	0683-1015	2	fxd comp 100Ω 5% 1/4W	01121	CB-1015
R143	0683-4325	1	fxd comp 4.3 k 5% 1/4 W	01121	CB-4325
R144, 146	0683-2015		fxd comp 200Ω 5% 1/4 W	01121	CB-2015
R147	0683-3015		fxd comp 300Ω 5% 1/4 W	01121	CB-3015
R148	0683-1025	1	fxd comp 1k 5% 1/4 W	01121	CB-1025
R149	0683-2225		fxd comp 2.2 k 5% 1/4 W	01121	CB-2225
R150	0683-4715	1	fxd comp 470Ω 5% 1/4 W	01121	CB-4715
R151	0683-6845	1	fxd comp 680 k 5% 1/4 W	01121	CB-6845
R152	0757-0279	1	fxd film 3.16 k 1% 1/8 W	24546	C4-1/8-TO-3161-F
R153-156	0757-0442		fxd film 10 k 1% 1/8 W	24546	C4-1/8-TO-1002-F
R157	0757-0465		fxd film 100 k 1% 1/8 W	24546	C4-1/8-TO-1003-F
R158			Not Used		
R159	0757-0442		fxd film 10 k 1% 1/8 W	24546	C4-1/8-TO-1002-F
R160	0698-4444		fxd film 4.87 k 1% 1/8 W	24546	C4-1/8-TO-4871-F
R161	0683-2025	1	fxd comp 2 k 5% 1/4 W	01121	CB-2025
R162	0757-0438	1	fxd film 5.11 k 1% 1/8 W	24546	C4-1/8-TO-5111-F
R163	0757-0200		fxd film 5.62 k 1% 1/8 W	24546	C4-1/8-TO-5621-F
R164	0683-2225		fxd comp 2.2 k 5% 1/4 W	01121	CB-2225
S1	3101-2528	1	switch, pushbutton, OVP DISPLAY	28480	
S2, 3	5060-9436	2	switch, pushbutton; OUTPUT ADJ LCL	28480	
U1, 2	1826-0876	2	IC, A/D Converter		
U3	1826-0138	1	IC, comparator quad	01295	LM339N
U4	1820-0493	2	IC, op amp	27014	LM307N
U5	1820-1112	1	IC, dual D-type pos-edge-trig FF	01295	SN74LS74AN
U6	1820-1298	3	IC, data select multiplex	01295	SN74LS251N
U7	1826-0493	2	IC, op amp	27014	LM308AN
U8	1826-0183	2	IC, comparator	07363	UA734HC
U9	1820-1298		IC, data select multiplex	01295	SN74LS251N
U10	1826-0493		IC, op amp	27014	LM308AN
U11	1826-0183		IC, comparator	07263	UA734HC
U12-14	1820-1729	3	IC, 8-bit addr latch	01295	SN74LS259N
U15	1820-1298		IC, data select multiplex	01295	SN74LS251N
U16	1820-0493		IC, op amp	27014	LM307N
VR1	1902-3092	1	zener 4.99 V 2%	28480	
VR2	1902-0575	2	zener 6.5 V 2%	28480	
VR3	1902-3149	1	zener 9.09 V 5%	28480	
VR4	1902-0575		zener 6.5 V 2%	28480	
VR5			Not Used		
VR6	1902-3104	1	zener 5.62 V 5%	28480	
<b>A3 Front Panel Assembly-Mechanical and Miscellaneous</b>					
	1200-0508	8	14 contact IC socket for DS1-8	28480	
	1200-0564	1	8 contact IC socket for DS9	28480	

Table 6-4. Replaceable Parts List (cont.)

Ref. Desig.	HP Part No.	TQ	Description	Mfr. Code	Mfr. Part No.
	1200-0940	1	Multi contact connector, SA socket	28480	
	1251-7401	2	Single contact connector	28480	
	4040-1615	16	LED standoffs	28480	
	06034-60004	1	Cable assembly for J1A, 1B	28480	
	06034-60005	1	Cable assembly for J2	28480	
	5020-5786	1	Coupler for G1	28480	
	1251-2615		16-pin mode conn.		
<b>A4</b>			<b>HP-IB/Microprocessor Assembly</b>		
C1			Not Used		
C2	0160-4722	11	fxd cer 0.1 $\mu$ f 50 V	28480	
C3, 4	0180-0291	4	fxd elect 1 $\mu$ f 35 V	56289	150D105X9035A2
C5	0140-0191	1	fxd mica 56pf 300 V 5%	28480	
C6	0160-4761	14	fxd cer 0.01 $\mu$ f 100 V	28480	
C7, 8	0160-4722		fxd cer 0.1 $\mu$ f 50 V	28480	
C9, 10			Not Used		
C11, 12	0180-0291		fxd elect 1 $\mu$ f 35 V	56289	150D105X9035A2
C13-17	0160-4722		fxd cer 0.1 $\mu$ f 50 V	28480	
C18, 19	0160-2197	3	fxd mica 10pf 300 V 5%	28480	
C20	0160-4761		fxd cer 0.01 $\mu$ f 100 V	28480	
C21			Not Used		
C22, 23	0160-4761		fxd cer 0.01 $\mu$ f 100 V	28480	
C24, 25			Not Used		
C26	0160-4761		fxd cer 0.01 $\mu$ f 100 V	28480	
C27			Not Used		
C28	0180-0634	2	fxd elect 180 $\mu$ f 50 V	00853	300ER181U050B
C29, 30	0160-4722		fxd cer 0.1 $\mu$ f 50 V	28480	
C31	0160-4761		fxd cer 0.01 $\mu$ f 100 V	28480	
C32, 33	0180-0230	4	fxd elect 1 $\mu$ f 50 V	56289	150D150X0050A2
C34	0180-0634		fxd elect 180 $\mu$ f 50 V	00853	300ER181U050B
C35	0180-0230		fxd elect 1 $\mu$ f 50 V	56289	150D105X0050A2
C36	0160-4761		fxd cer 0.01 $\mu$ f 100 V	28480	
C37			Not Used		
C38-41	0150-0121	4	fxd cer 0.1 $\mu$ f 50 V	28480	
C42	0160-0263	4	fxd cer 0.22 $\mu$ f 50 V	28480	
C43			Not Used		
C44-47	0160-4761		fxd cer 0.01 $\mu$ f 100 V	28480	
C48	0160-2735	1	fxd mica 1000pf 100 V 5%	28480	
C49	0180-1893	2	fxd elect 1450 $\mu$ f 45 V	28480	
C50	0180-2796	2	fxd elect 6300 $\mu$ f 20 V	00853	500632U020AA2B
C51	0170-0019	1	fxd film 0.1 $\mu$ f 200 V 5%	28480	
C52, 53			Not Used		
C54	0180-2695	2	fxd elect 1000 $\mu$ f 12 V	00853	301AER101U012B
C55	0160-0127	3	fxd cer 1 $\mu$ F 25 V	28480	
C56	0160-2197		fxd mica 10pf 300 V 5%	28480	
C57	0180-1893		fxd elect 1450 $\mu$ f 45 V	28480	
C58	0180-2796		fxd elect 6300 $\mu$ f 20 V	00853	500632U020AA2B

Table 6-4. Replaceable Parts List (cont.)

Ref. Desig.	HP Part No.	TQ	Description	Mfr. Code	Mfr. Part No.
C59	0160-0263		fxd cer 0.22 $\mu$ f 50 V	28480	
C60			Not Used		
C61	0160-0263		fxd cer 0.22 $\mu$ f 50 V	28480	
C62	0180-2695		fxd elect 1000 $\mu$ f 12 V	00853	301AER102U012B
C63	0810-0230		fxd elect 1 $\mu$ f 50 V	56289	150D105X0050A2
C64			Not Used		
C65	0160-4761		fxd cer 0.01 $\mu$ f 100 V	28480	
C66			Not Used		
C67, 68	0160-4761		fxd cer 0.01 $\mu$ f 100 V	28480	
C69	0160-0263		fxd cer 0.22 $\mu$ f 50 V	28480	
C70			Not Used		
C71, 72	0160-3070	2	fxd mica 100pf 300 V 5%	28480	
C73, 74	0160-0127		fxd cer 1 $\mu$ f 25 V	28480	
C75, 76	0160-0904	2	fxd cer 0.05 $\mu$ f 1k V	28480	
C77	0160-4722		fxd cer 0.1 $\mu$ f 50 V	28480	
CR1, 2	1901-0033	6	diode 200mA 180 V	28480	
CR3			Not Used		
CR4-7	1901-0327	11	power rect. 1 A 200 V	03508	A14B
CR8, 9	1901-0418	2	power rect. 1.5 A 400 V	28480	
CR10-13	1901-0327		power rect. 1 A 200 V	03508	A14B
CR14, 15	1901-0418		power rect. 1.5 A 400 V	28480	
CR16, 17	1901-0327		power rect. 1 A 200 V	03508	A14B
CR18			Not Used		
CR19	1901-0327		power rect. 1 A 200 V	03508	A14B
CR20-23	1901-0050	4	diode switching 200 mA 80 V	28480	
CR24			Not Used		
CR25-28	1901-0033		diode 200 mA 180 V	28480	
DS1, 2	1990-0486	2	LED	28480	
F1	2110-0063	1	fuse 0.75 A 250 V	28480	
J1	1251-5722	1	50 pin connector	28480	
J2	1258-0189	2	connector	28480	
J3	1251-4303	1	15 pin connector	28480	
J4	1251-3283		24 pin connector	28480	
J5	1258-0189		connector	28480	
Q1, 2	1854-0823	10	NPN Si	28480	
Q3	1853-0036	2	PNP Si	28480	
Q4			Not Used		
Q5	1853-0036		PNP Si	28480	
Q6, 7			Not Used		
Q8-15	1854-0823		NPN Si	28480	
R1			Not Used		
R2	0757-0279	2	fxd film 3.16 k 1% 1/8 W	24546	C4-1/8-TO-3161-F
R3	0757-0422	1	fxd film 909 $\Omega$ 1% 1/8 W	28480	
R4	0757-0279		fxd film 3.16 k 1% 1/8 W	24546	C4-1/8-TO-3161-F
R5	0683-3915	4	fxd comp 390 $\Omega$ 5% 1/4 W	01121	CB-3915
R6	0683-3615	3	fxd comp 360 $\Omega$ 5% 1/4 W	01121	CB-3615
R7	0683-1025	4	fxd comp 1k 5% 1/4 W	01121	CB-1025

Table 6-4. Replaceable Parts List (cont.)

Ref. Desig.	HP Part No.	TQ	Description	Mfr. Code	Mfr. Part No.
R8	0683-3015	2	fxd comp 300Ω 5% 1/4 W	01121	CB-3015
R9	0683-3915		fxd comp 390Ω 5% 1/4 W	01121	CB-3915
R10, 11	0683-7515	3	fxd comp 750Ω 5% 1/4 W	01121	CB-7515
R12	0683-3615		fxd comp 360Ω 5% 1/4 W	01121	CB-3615
R13	0683-7515		fxd comp 750Ω 5% 1/4 W	01121	CB-7515
R14	0683-2025	3	fxd comp 2 k 5% 1/4 W	01121	CB-2025
R15	0683-3915		fxd comp 390Ω 5% 1/4 W	01121	CB-3915
R16, 17	0683-1035	3	fxd comp 10 k 5% 1/4 W	01121	CB-1035
R18	0683-3615		fxd comp 360Ω 5% 1/4 W	01121	CB-3615
R19	0683-3015		fxd comp 300Ω 5% 1/4 W	01121	CB-3015
R20	0683-1025		fxd comp 1k 5% 1/4 W	01121	CB-1025
R21	0683-2025		fxd comp 2 k 5% 1/4 W	01121	CB-2025
R22, 23			Not Used		
R24	0698-3162	1	fxd film 46.4 k 1% 1/8 W	24546	C4-1/8-TO-4642-F
R25	0698-5808	2	fxd film 4 k 1% 1/8 W	24546	C4-1/8-TO-4001-F
R26	0757-0289	1	fxd film 13.3 k 1% 1/8 W	19701	MF4C1/8-TO-1332-F
R27			Not Used		
R28	0757-0408	2	fxd film 243Ω 1% 1/8 W	24546	C4-1/8-TO-243R-F
R29	0757-0280	2	fxd film 1 k 1% 1/8 W	24546	C4-1/8-TO-1001-F
R30	0698-5089	1	fxd film 33 k 1% 1/8 W	24546	C4-1/8-TO-3302-F
R31	0698-3327	2	fxd film 3.92 k 0.5% 1/8 W	28480	
R32	0757-0404	2	fxd film 130Ω 1% 1/8 W	24546	C4-1/8-TO-131-F
R33	0683-1025		fxd comp 1 k 5% 1/4 W	01121	CB-1025
R34-38	0683-4725	5	fxd comp 4.7 k 5% 1/4 W	01121	CB-4725
R39			Not Used		
R40	0757-0408		fxd film 243Ω 1% 1/8 W	24546	C4-1/8-TO-243R-F
R41	0698-3159	1	fxd film 26.1 k 1% 1/8 W	24546	C4-1/8-TO-2612-F
R42	0757-0280		fxd film 1 k 1% 1/8 W	24546	C4-1/8-TO-1001-F
R43	0757-0404		fxd film 130Ω 1% 1/8 W	24546	C4-1/8-TO-131-F
R44	0698-0064	1	fxd film 9.31 k 1% 1/8 W	24546	C4-1/8-TO-9311-F
R45	0698-6631	1	fxd film 2.5 k 0.1% 1/8 W	28480	
R46-50			Not Used		
R51	0683-1025		fxd comp 1 k 5% 1/4 W	01121	CB-1025
R52	0757-0413	5	fxd film 392Ω 1% 1/8 W	24546	C4-1/8-TO-392R-F
R53			Not Used		
R54	0698-3202	3	fxd film 1.74 k 1% 1/8 W	24546	C4-1/8-TO-1741-F
R55			Not Used		
R56	0757-0413		fxd film 392Ω 1% 1/8 W	24546	C4-1/8-TO-392R-F
R57	0757-0436	4	fxd film 4.32 k 1% 1/8 W	24546	C4-1/8-TO-4321-F
R58	0757-0439	2	fxd film 6.81 k 1% 1/8 W	24546	C4-1/8-TO-6811-F
R59	0757-0436		fxd film 4.32 k 1% 1/8 W	24546	C4-1/8-TO-4321-F
R60	0757-0413		fxd film 392Ω 1% 1/8 W	24546	C4-1/8-TO-392R-F
R61	0757-0458	2	fxd film 51.1 k 1% 1/8 W	24546	C4-1/8-TO-5112-F
R62	0757-0400	1	fxd film 90.9 1% 1/8 W	24546	C4-1/8-TO-90R0-F
R63	0698-5868		fxd film 190Ω 1% 1/8 W	24546	C4-1/8-TO-190R-F
R64	0757-0413		fxd film 392Ω 1% 1/8 W	24546	C4-1/8-TO-392R-F

Table 6-4. Replaceable Parts List (cont.)

Ref. Desig.	HP Part No.	TQ	Description	Mfr. Code	Mfr. Part No.
R65	0698-3202		fxd film 1.74 k 1% 1/8 W	24546	C4-1/8-TO-1741-F
R66			Not Used		
R67	0698-3202		fxd film 1.74 k 1% 1/8 W	24546	C4-1/8-TO-1741-F
R68	0757-0413		fxd film 392 $\Omega$ 1% 1/8 W	24546	C4-1/8-TO-392R-F
R69	0757-0436		fxd film 4.32 k 1% 1/8 W	24546	C4-1/8-TO-4321-F
R70	0757-0439		fxd film 6.81 k 1% 1/8 W	24546	C4-1/8-TO-6811-F
R71	0698-5808		fxd film 4 k 1% 1/8 W	24546	C4-1/8-TO-4001-F
R72	0757-0436		fxd film 4.32 k 1% 1/8 W	24546	C4-1/8-TO-4321-F
R73	0757-0421	1	fxd film 825 $\Omega$ 1% 1/8 W	28480	
R74	0757-0458		fxd film 51.1 k 1% 1/8 W	24546	C4-1/8-TO-5112-F
R75	0698-3444	1	fxd film 316 $\Omega$ 1% 1/8 W	24546	C4-1/8-TO-316R-F
R76	0698-7961	1	fxd film 80.6 k 1% 1/8 W	19701	MF4C1/8-T9-8061-F
R77			Not Used		
R78	0698-3327		fxd film 3.92 k 0.5% 1/8 W	28480	
R79			Not Used		
R80	0683-1035		fxd comp 10 k 5% 1/4 W	01121	CB-1035
R81-85	0757-0283	5	fxd film 2 k 1% 1/8 W	24546	C4-1/8-TO-2001-F
R86, 87	0757-0438	2	fxd film 5.11 k 1% 1/8 W	24546	C4-1/8-TO-5111-F
R88	0683-2025		fxd comp 2 k 5% 1/4 W	01121	CB-2025
R89	0683-3915		fxd comp 390 $\Omega$ 5% 1/4 W	01121	CB-3915
S1	3101-0447	1	switch	28480	
S2	3101-1860	1	switch	28480	
T1-3	5080-1924	3	pulse transformer	28480	
TP1-17	1251-0646	17	contact connector	28480	
U1	1820-1112	7	IC, dual D-type pos-edge-trig FF	01295	SN74LS74AN
U2	1820-1144	1	IC, quad 2 inp pos-nor gate	01295	SN74LS02N
U3	1820-1208	5	IC, quad 2 inp pos-or gate	01295	SN74LS32N
U4			Not Used		
U5	1AA7-6002	1	IC, chi chip	28480	
U6	1826-0188	1	IC, conv 8-bit D/A	04713	MC1408L-8
U7	1820-1858	4	IC, octal D-type FF	01295	SN74LS377N
U8	1820-1729	4	IC, 8-bit addr. latch	01295	SN74LS259N
U9, 10	1813-0094	2	IC, conv 12-bit D/A	28480	
U11	1820-1208		IC, quad 2 inp pos-or gate	01295	SN74LS32N
U12	1820-1195	3	IC, quad D-type FF	01295	SN74LS175N
U13	1820-1208		IC, quad 2 inp pos-or gate	01295	SN74LS32N
U14	1820-1858		IC, octal D-type FF	01295	SN74LS377N
U15	1820-1729		IC, 8-bit addr. latch	01295	SN74LS259N
U16	1820-1858		IC, octal D-type FF	01295	SN74LS377N
U17	1820-1729		IC, 8-bit addr. latch	01295	SN74LS259N
U18	1820-1858		IC, octal D-type FF	01295	SN74LS377N
U19	1820-1729		IC, 8-bit addr. latch	01295	SN74LS259N
U20	1820-1201	3	IC, quad 2 inp pos-and gate	01295	SN74LS08AN
U21	1820-1199	6	IC, hex inverter	01295	SN74LS04N
U22	1820-1427	1	IC, decoder/demulti	01295	SN74LS156N
U23 U24			Not Used		
U25	1818-3113	1	IC, 64K ROM	28480	

Table 6-4. Replaceable Parts List (cont.)

Ref. Desig.	HP Part No.	TQ	Description	Mfr. Code	Mfr. Part No.
U26	1820-1199		IC, hex inverter	01295	SN74LS04N
U27	1820-2747	1	IC, microprocessor		
U28	1820-1207	2	IC, 8 inp pos-nand gate	01295	SN74LS30AN
U29, 30	1820-1216	2	IC, 3 to 8 line decoder/demulti	01295	SN74LS138N
U31	1820-1491	4	IC, hex bus drivers	01295	SN74LS367N
U32, 33	1818-0140	2	IC, N mos 1 k ram stat	55576	SYP2112A
U34	1820-1419	1	IC, 4-bit mag comp.	01295	SN74LS85N
U35	1820-1195		IC, quad D-type FF	01295	SN74LS175N
U36	1820-1568	2	IC, quad bus buff gate 3-out	01295	SN74LS125N
U37	1990-0593	5	IC, opto isolator	04713	SOC-156
U38, 39	1990-0429	2	IC, opto isolator	28480	
U40, 41	1820-1446	2	IC, 4-bit uni shift regis.	01295	SN74LS395N
U42	1820-1204	1	IC, dual 4 inp pos-nand gate	01295	SN74LS20AN
U43	1820-1282	1	IC, dual J-K pos-edge-trig FF	01295	SN74LS109N
U44	1820-1197	1	IC, quad 2 inp pos-nand gate	01295	SN74LS00N
U45	1820-1203	2	IC, trip 3 inp pos-and gate	01295	SN74LS11N
U46	1820-1199		IC, hex inverter	01295	SN74LS04N
U47	1820-1201		IC, quad 2 inp pos-and gate	01295	SN74LS08AN
U48-50	1820-1491		IC, hex bus driver	01295	SN74LS367N
U51	1820-1196	1	IC, hex D-type FF	01295	SN74LS174N
U52	1820-1851	1	IC, 8 to 3 line octal prior. encoder	01295	SN74LS148
U53	1990-0593		IC, opto isolator	04713	SOC-156
U54-56	1820-1112		IC, dual D-type pos-edge-trig. FF	01295	SN74LS74AN
U57-59			Not Used		
U60	1826-0277	1	IC, vltg reg.	27014	LM320T-15
U61	1826-0147	2	IC, vltg reg.	04713	MC7812CT
U62	1820-1195		IC, quad D-type FF	01295	SN74LS175N
U63	1820-1211	1	IC, quad 2 inp ex-or gate	01295	SN74LS86N
U64	1820-1199		IC, hex inverter	01295	SN74LS04N
U65	1820-1207		IC, 8 inp pos-nand gate	01295	SN74LS30AN
U66	1826-0607	1	IC, vltg reg	27014	LM340AT-15
U67			Not Used		
U68	1820-1112		IC, dual D-type pos-edge-trig FF	01295	SN74LS74AN
U69	1820-1208		IC, quad 2 inp pos-or gate	01295	SN74LS32N
U70	1820-1112		IC, dual D-type pos-edge-trig FF	01295	SN74LS74AN
U71	1820-1199		IC, hex inverter	01295	SN74LS04N
U72	1820-1437	2	IC, dual monostable multi-vibrator	01295	SN74LS221N
U73	1826-0144	1	IC, vltg reg	04713	MC7805CP
U74	1820-1437		IC, dual monostable multi-vibrator	01295	SN74LS221N
U75	1820-1201		IC, quad 2 inp pos-and gate	01295	SN74LS08AN
U76	1820-1208		IC, quad 2 inp pos-or gate	01295	SN74LS32N
U77	1820-1203		IC, trip 3-inp pos-and gate	01295	SN74LS11N
U78	1820-1112		IC, dual D-type pos-edge-trig FF	01295	SN74LS74AN
U79	1820-1568		IC, quad bus buff gate 3-out	01295	SN74LS125N
U80-83	1820-2058	4	IC, quad bus transceiver	28480	
U84	1820-1199		IC, hex inverter	01295	SN74LS04N
U85	1826-0147		IC, vltg reg.	04713	MC7812CT

Table 6-4. Replaceable Parts List (cont.)

Ref. Desig.	HP Part No.	TQ	Description	Mfr. Code	Mfr. Part No.
U86			Not Used		
U87	1820-0493	1	IC, op amp	27014	LM307N
U88, 89	1990-0593		IC, opto isolator	04713	SOC-156
U90			Not Used		
U91	1990-0593		IC, opto isolator	04713	SOC-156
VR1	1902-0761	1	zener 6.2 V	04713	IN821
VR2, 3			Not Used		
VR4	1902-0575	2	zener 6.5 V 2%	28480	
VR5	1902-0671	2	zener 13.35 V	28480	
VR6			Not Used		
VR7	1902-0671		zener 13.35 V	28480	
VR8			Not Used		
VR9	1902-0575		zener 6.5 V 2%	28480	
W1-18	7175-0057		jumper wire		
Y1	0410-1033	1	crystal 9.216 MHz	28480	
Z1	1810-0125	1	resistor network	28480	
<b>A4 HP-1B/Microprocessor Board-Mechanical and Miscellaneous</b>					
	0340-1067	4	Insulating bushings for CR8, 9, 14, 15	28480	
	0590-0199	7	Hex nut with lockwasher for U60, 61, 66, 73, 85, J4	28480	
	1200-0485	1	14 contact IC socket for S2	28480	
	1200-0507	1	16 contact IC socket	28480	
	1200-0624	1	40 contact IC socket for U27	28480	
	1200-0634	3	IC socket for U24, 25, 90	28480	
	1200-0847	1	Socket for U5	28480	
	1200-0844	2	Clip for U5	28480	
	1205-0348	5	Heatsinks for U60, 61, 66, 73, 85	28480	
	1251-4787	1	8 position shunt	28480	
	1251-7397	1	Multi contact connector for JU5	28480	
	1251-7400	1	Multi contact connector for J2	28480	
	1530-1098	1	Clevis fastener for J4	28480	
	2110-0269	1	Fuseholder for F1	28480	
	4330-0145	2	Beaded glass insulator for Y1	28480	
	06034-60001	1	Cable Assembly	28480	
	1251-7401		Single-contact connector for J4		
<b>A5</b>			<b>Regulator Assembly</b>		
Q1-5			Not Used		
Q6	1854-0611	1	NPN Si	04713	2N6055
Q7	1853-0059	1	PNP Si	04713	2N3791
R1	0811-0929	1	fxd ww 0.51 $\Omega$ 5% 2 W	75042	BWH2-R51-J
R2	0683-1005	1	fxd comp 10 $\Omega$ 5% 1/4 W	01121	CB-1005
R3	0812-0019	1	fxd ww 0.33 $\Omega$ 5% 3 W	28480	

Table 6-4. Replaceable Parts List (cont.)

Ref. Desig.	HP Part No.	TQ	Description	Mfr. Code	Mfr. Part No.
<b>A5 Regulator Assembly-Mechanical and Miscellaneous</b>					
	0340-0167	4	Insulated bushings	28480	
	1251-2913	4	Single contact connector	28480	
	0340-0181	2	Insulator for Q6, 7	28480	
	0340-0795	2	Insulator for Q6, 7	28480	
<b>Chassis Components-Electrical</b>					
B1	3160-0343	1	Fan-tbox	82877	SUZA5
F1	2110-0056	1	Fuse-6A, 250 V (100 or 120 Vac input)	71400	MTH-6
F1	2110-0055	1	Fuse-4A, 250 V (220 or 240 Vac Input)	71400	MTH-4
FL1	9135-0124	1	RFI filter and ac input connector	28480	
T1	06034-80090	1	power transformer	28480	
<b>Chassis-Mechanical</b>					
	0360-0523	2	Barrier block jumper	28480	
	0370-1303	1	Knob for G1	28480	
	2110-0564	1	Fuseholder body	H9027	031.1657
	2110-0565	1	Fuseholder cap	H9027	031.1666
	2110-0569	1	Fuseholder nut	75915	272005
	4040-1954	1	Window Display	28480	
	4208-0382	4	Foam pad, top cover	28480	
	5020-8803	1	Front frame	28480	
	5041-0202	1	Line switch cap	28480	
	5041-0300	1	OVP Display switch cap	28480	
	5041-0309	1	Voltage OUTPUT ADJUST switch cap	28480	
	5041-2089	1	LCL switch cap	28480	
	06034-00009	1	Rear panel	28480	
	60034-00008	1	Front panel	28480	
	06034-00010	1	Front chassis	28480	
	06034-00011	2	Side chassis	28480	
	06034-00012	1	Baffle	28480	
	06034-00013	1	Bottom cover	28480	
	06034-00014	1	Top cover	28480	
	06034-00015	1	Safety cover, barrier block	28480	
	06034-00016	2	Side Cover	28480	
	06034-00018	2	Bar insulator	28480	
	06034-00019	1	P.C. bracket	28480	
	7120-1254	1	Nameplate	28480	
	7120-7659	1	104-127 V Label	28480	
	7120-7661	1	191-233 V Label (Option 220)	28480	
	7120-7660	1	208-250 V label (Option 240)	28480	
	7120-8572	1	Information label	28480	
	7121-1967	1	Serial number label	28480	
	9211-3487	1	Corrugated container	28480	
	9220-1401	2	Floater pad	28480	
	9220-3390	2	Filler	28480	



## Section VII

# COMPONENT LOCATION ILLUSTRATIONS AND CIRCUIT DIAGRAMS

7-1 This section contains component location diagrams, schematics, and other drawings and tables useful for maintenance of the 6034A power supply. Included in this section are:

- a. Component location illustrations (Figures 7-1 through 7-5), showing the physical location and reference designators of almost all electrical parts. (Components located on the A5 Regulator Assembly are easily identified by lettering on the printed-circuit board.)
- b. Notes (Table 7-1) that apply to all the schematic diagrams.
- c. Microprocessor Input/Output Pins table (Table 7-2) describing each of the pins on microprocessor A4U27.
- d. Memory Device Jumpers and Components table (Table 7-3) indicating which jumpers are installed for each combination of memory components.
- e. Schematic diagrams (Figures 7-6 through 7-10). Logic symbols used on the schematics are described in Appendix B.

### WARNING

*AC line voltage is present on the A4 HP-IB/Microcomputer Assembly whenever the power cord is connected to an ac power source.*

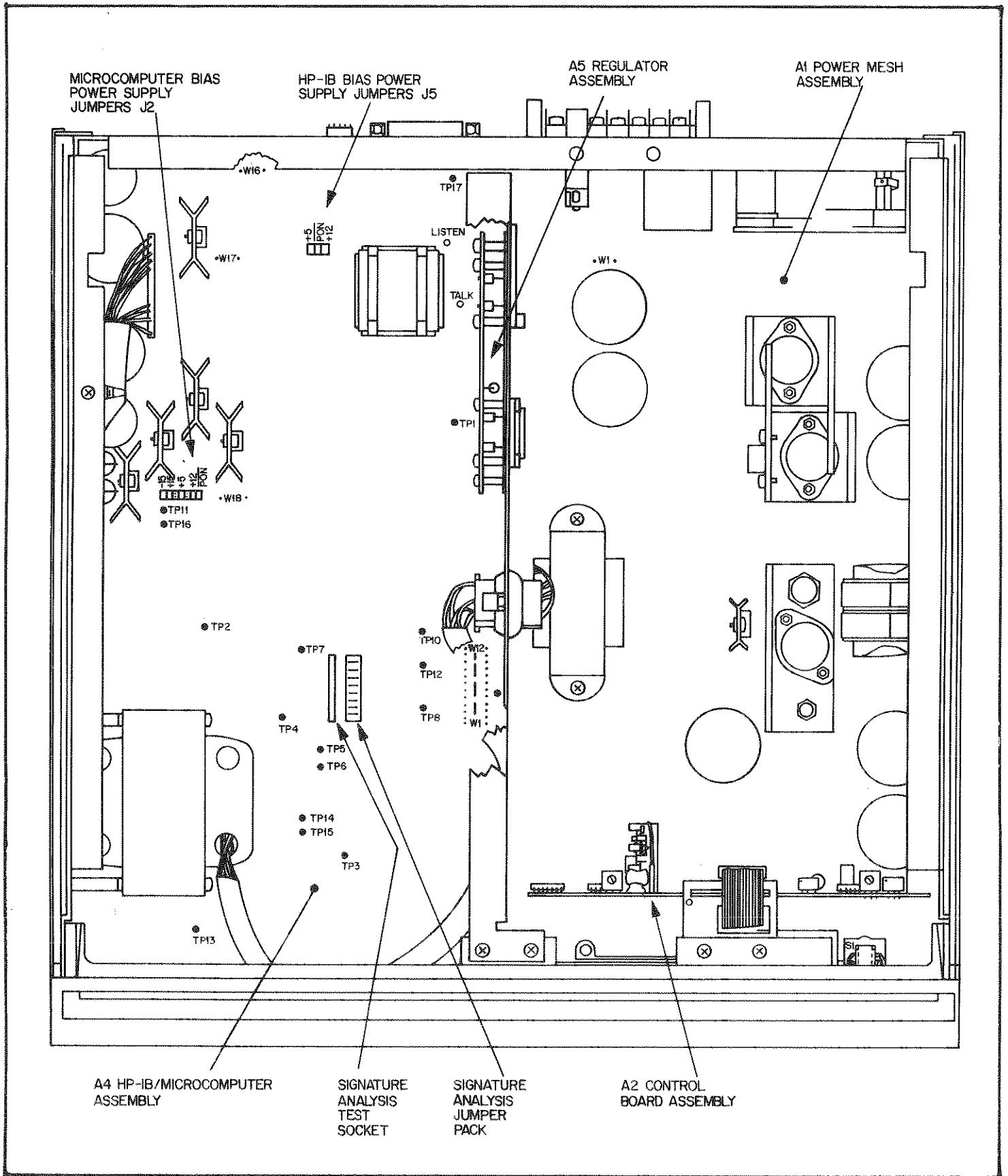

Figure 7-1. Top View, Top Cover Removed

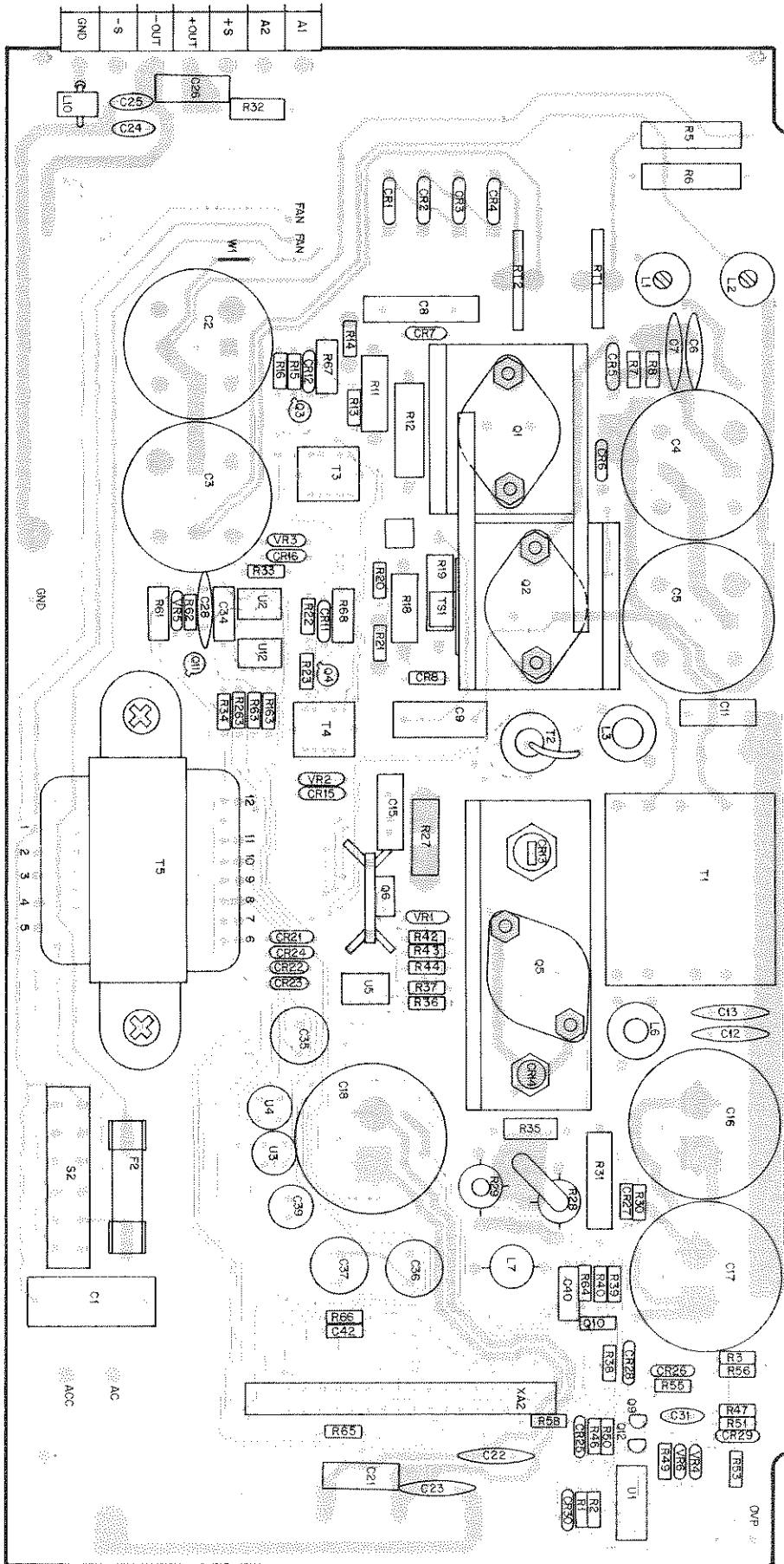

Figure 7-2. Power Mesh (A1) Component Location

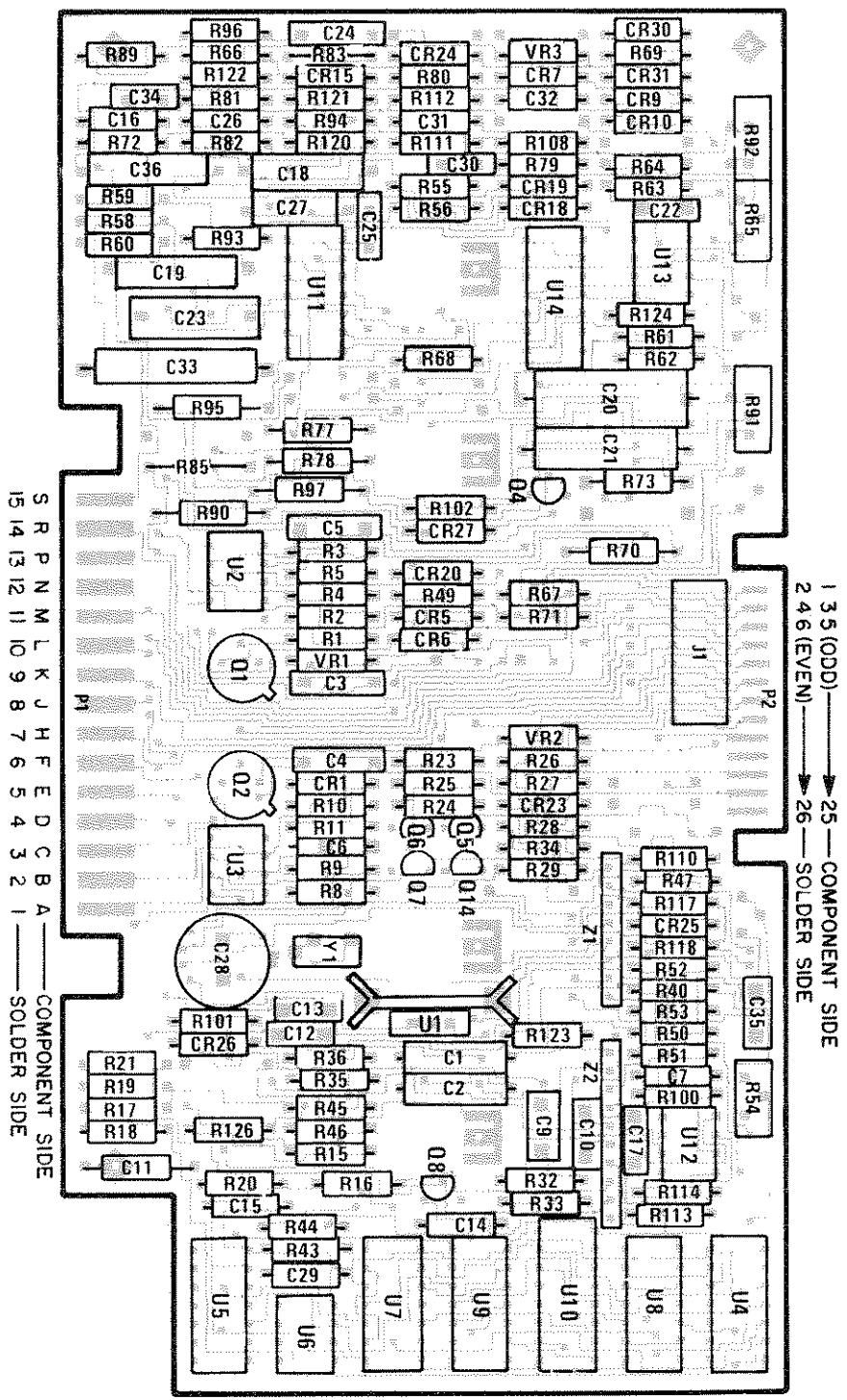

Figure 7-3. Control Board (A2) Component Location

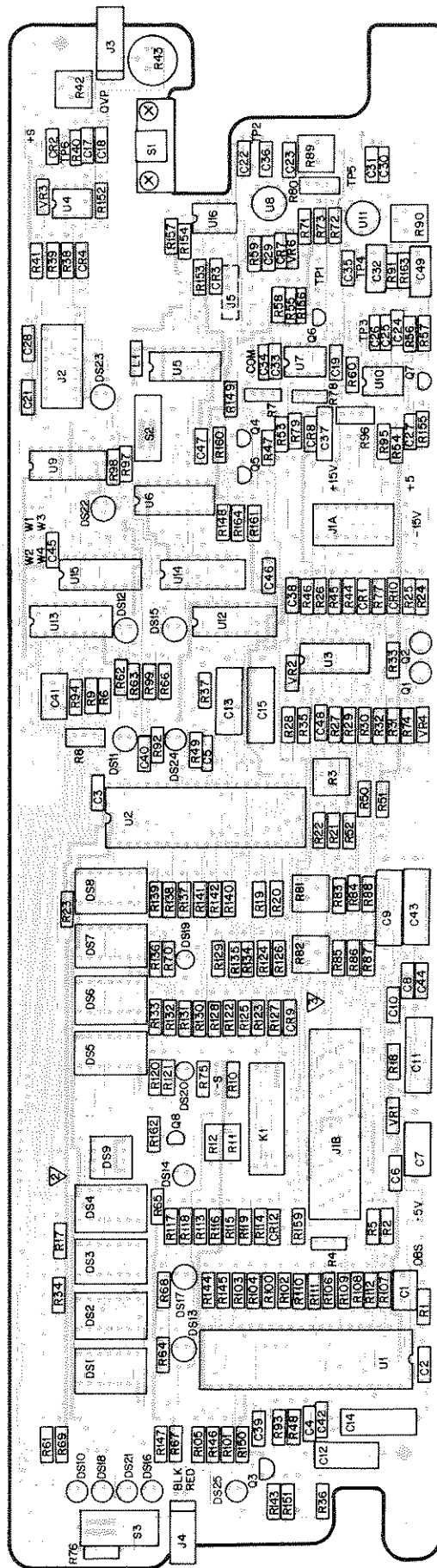

Figure 7-4. Front Panel (A3) Component Location

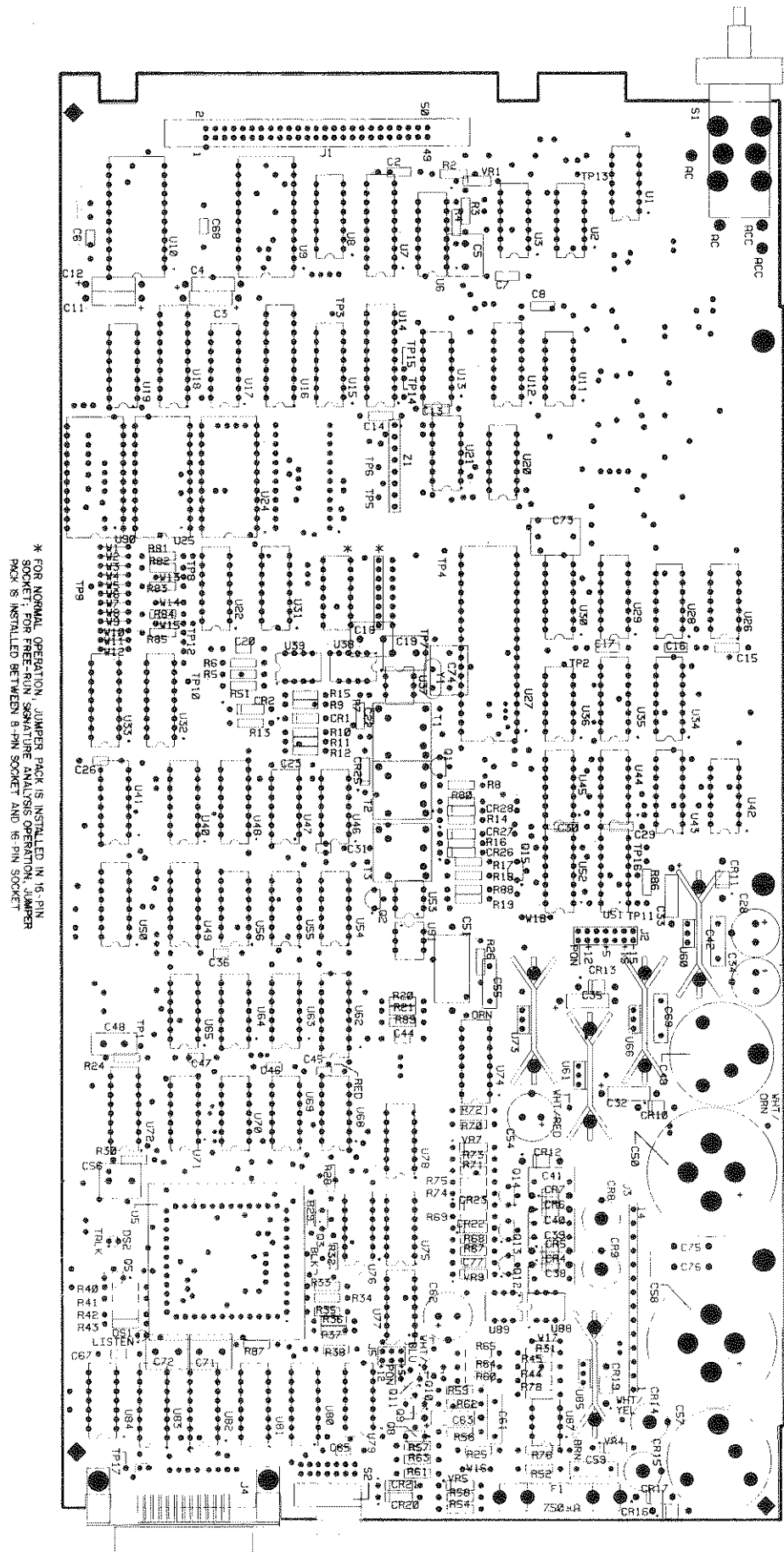
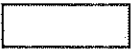

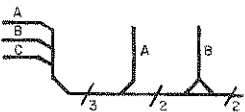
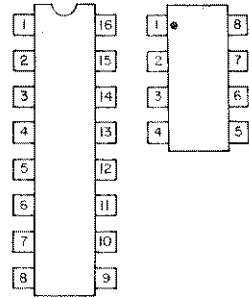

Figure 7-5. HP-IB/Microcomputer (A4) Component Location

**Table 7-1. Schematic Diagram Notes**

1.  denotes front-panel marking.
2.  denotes rear-panel marking.
3. Complete reference designator consists of component reference designator prefixed with assembly number (e.g.: A2R14).
4. Resistor values are in ohms. Unless otherwise noted, resistors are either ¼ W, 5% or 1/8 W, 1%. Parts list provides power rating and tolerance for all resistors.
5. Unless otherwise noted, capacitor values are in microfarads.
6. Square p.c. pads on A1 power mesh, and white silkscreened dots on other assemblies indicate one of the following:
  - a. pin 1 of an integrated circuit or connector.
  - b. the cathode of a diode or emitter of a transistor.
  - c. the positive end of a polarized capacitor.
7. Some components that connect two circuits, such as connectors, transformers, and optical connectors, are shown in more than one location. In each case, the dashed-line portion represents part of the component that is shown solidly in another circuit.
8.  indicates multiple paths represented by only one line. Reference designators with pin numbers indicate destination, or signal names identify individual paths. Numbers indicate number of paths represented by the line.
9. For dual in-line integrated circuit packages, pin 1 is either marked with a dot, or pin 1 is to the left (as viewed from top) of indentation at end of integrated circuit package, e.g:



Pin locations for other semi-conductors are shown below:

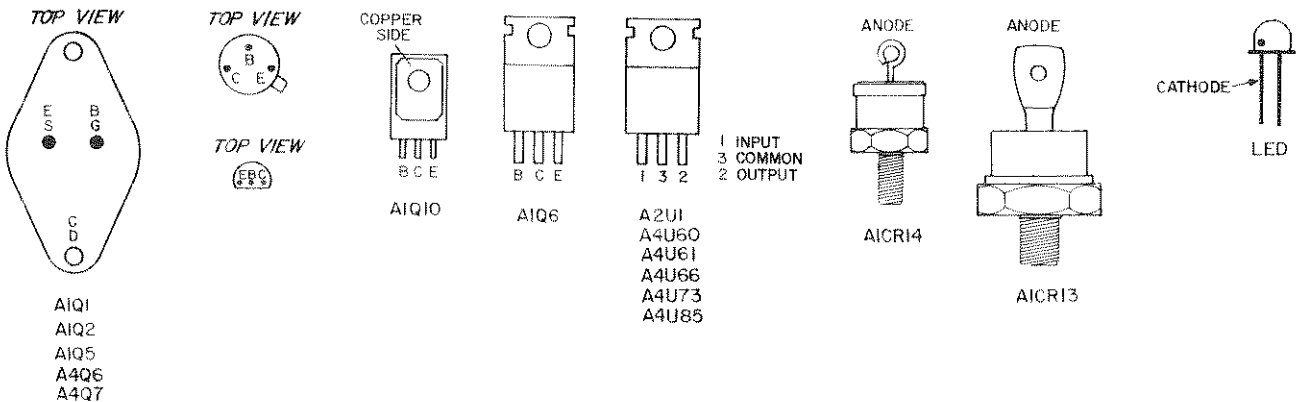

Table 7-2. Microprocessor Input/Output Pins

SIGNATURE	PIN	I/O	DESCRIPTION
<b>ADDRESS BUS</b>			
A0(MSB)	17	OUT	A0 through A13 comprise the address bus. This 3-state bus provides the memory-address vector to the external-memory system when MEMEN is active and I/O-bit addresses and external-instruction addresses to the I/O system when MEMEN is inactive. The address bus assumes the high-impedance state when HOLDA is active.
A1	16	OUT	
A2	15	OUT	
A3	14	OUT	
A4	13	OUT	
A5	12	OUT	
A6	11	OUT	
A7	10	OUT	
A8	9	OUT	
A9	8	OUT	
A10	7	OUT	
A11	6	OUT	
A12	5	OUT	
A13/CRUOUT	4	OUT	<p style="text-align: center;"><b>CRUOUT</b></p> <p>Serial I/O data appears on A13 when an LDCR, SBZ and SBO instruction is executed. This data should be sampled by the I/O interface logic when CRUCLK goes active (high). One bit of external instruction code appears on A13 during external instruction execution.</p>
<b>DATA BUS</b>			
D0(MSB)	25	I/O	D0 through D7 comprise the bidirectional 3-state data bus. This bus transfers memory data to (when writing) and from (when reading) the external-memory system when MEMEN is active. The data assumes the high-impedance state when HOLDA is active.
D1	26	I/O	
D2	27	I/O	
D3	28	I/O	
D4	29	I/O	
D5	30	I/O	
D6	31	I/O	
D7 (LSB)	32	I/O	
<b>POWER SUPPLIES</b>			
V <sub>CC</sub>	20		Supply voltage (5 V NOM)
V <sub>DD</sub>	36		Supply voltage (12 V NOM)
V <sub>SS</sub>	35		Ground reference
<b>CLOCKS</b>			
CKIN	34	IN	Clock In and Oscillator Out. These pins may be used in either of two modes to generate the internal 4 phase clock. In mode 1 a crystal of 4 times the desired system frequency is connected between CKIN and OSCOUT. In mode 2 OSCOUT is left floating and CKIN is driven by a TTL compatible source whose frequency is 4 times the desired system frequency.
OSCOUT	33	OUT	
$\overline{\text{Ø3}}$	21	OUT	Clock phase 3 ( $\overline{\text{Ø3}}$ ) inverted.
<b>BUS CONTROL</b>			
DBIN	18	OUT	Data bus in. When active (high), DBIN indicates that the TMS 9981 has disabled its output buffers to allow the memory to place memory-read data on the data bus during MEMEN. DBIN remains low in all other cases when HOLDA is active.
MEMEN	40	OUT	Memory enable. When active (low), $\overline{\text{MEMEN}}$ indicates that the address bus contains a memory address.

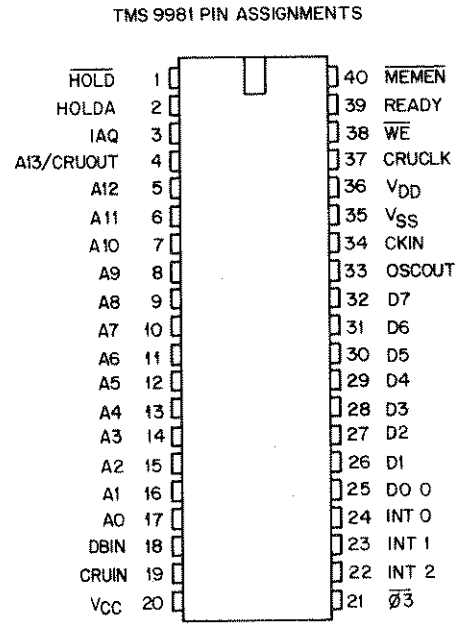



Table 7-2. Microprocessor Input/Output Pins (cont.)

SIGNATURE	PIN	I/O	DESCRIPTION
$\overline{\text{WE}}$	38	OUT	Write enable. When active (low), $\overline{\text{WE}}$ indicates that memory-write data is available from the TMS 9981 to be written into memory.
CRUCLK	37	OUT	CRU clock. When active (high), CRUCLK indicates that external interface logic should sample the output data on CRUOUT or should decode external instructions on A0, A1, A13.
CRUIN	19	IN	CRU data in. CRUIN, normally driven by 3-state or open-collector devices, receives input data from external interface logic. When the processor executes a STCR or TB instruction, it samples CRUIN for the level of the CRU input bit specified by the address bus (A2 through A12).
INT2	22	IN	Interrupt code. In the format INT0, INT1, INT2, 111 is level 4, 101 is level 3, 100 is level 2, and 011 is level 1 (highest priority). Reset function is encoded 000.
INT1	23	IN	
INT0	24	IN	
$\overline{\text{HOLD}}$	1	IN	<p style="text-align: center;"><b>MEMORY CONTROL</b></p> Hold. When active (low), $\overline{\text{HOLD}}$ indicates to the processor that an external controller (e.g., DMA device) desires to utilize the address and data buses to transfer data to or from memory. The TMS 9981 enters the hold state following a hold signal when it has completed its present memory cycle.* The processor then places the address and data buses in the high-impedance state (along with $\overline{\text{WE}}$ , $\overline{\text{MEMEN}}$ , and DBIN) and responds with a hold-acknowledge signal (HOLDA). When $\overline{\text{HOLD}}$ is removed, the processor returns to normal operation.
HOLDA	2	OUT	Hold acknowledge. When active (high), HOLDA indicates that the processor is in the hold state and the address and data buses and memory control outputs ( $\overline{\text{WE}}$ , $\overline{\text{MEMEN}}$ , and DBIN) are in the high-impedance state.
READY	39	IN	Ready. When active (high), READY indicates that memory will be ready to read or write during the next clock cycle. When not-ready is indicated during a memory operation, the TMS 9981 enters a wait state and suspends internal operation until the memory systems indicate ready.
IAQ	3	OUT	<p style="text-align: center;"><b>TIMING AND CONTROL</b></p> Instruction acquisition. IAQ is active (high) during any memory cycle when the TMS 9981 is acquiring an instruction. IAQ can be used to detect illegal op codes. It may also be used to synchronize LOAD stimulus.

\*If the cycle following the present memory cycle is also a memory cycle it, too, is completed before TMS 9981 enters hold state.

Reprinted with changes, courtesy Texas Instruments Incorporated.

**Table 7-3. Memory Device Jumpers and Components**

	U25	U24	U90	W1	W2	W3	W4	W5	W6	W13	W14	W15
64 K ROM	X				X		X			X	X	X
16K EPROM	X	X	X	X		X		X				
	W7	W8	W9	W10	W11	W12	U32	U33				
1 K RAM		X	X			X	X	X				
256 RAM	X			X	X		X	X				
<p>"X" SHOWS WHICH COMPONENTS ARE INSTALLED FOR EACH MEMORY-DEVICE CONFIGURATION.</p>												

## Appendix A 100 Vac INPUT POWER OPTION 100

### A-1 GENERAL INFORMATION

#### A-2 Description

A-3 Option 100 is a modification of Model 6034A that involves adding a resistor, and changing five others in the OVP Remote and Local Circuits, the CV Reference Circuit and the CV Comparator Circuit. The unit is also recalibrated and the Front Panel is changed for the Option 100. These changes allow the unit to operate at a lower line voltage of 87 to 106 Vac, while operating on the same line frequency of 48 to 63 Hz. The reduced input voltage limits the output power to 150 W and the output voltage from 0 to 50 V, while retaining the standard unit's output current rating. Other parameters that change due to Option 100 include the Overvoltage Trip Range and the Remote Programming Specifications.

#### A-4 Scope of Appendix A

A-5 This appendix contains all the information necessary to support Model 6034A power supplies that are equipped with Option 100. The appendix describes only the changes pertaining to Option 100 and how they affect the other portions of this manual. Unless otherwise specified in Appendix A, all other portions of the manual apply to both the standard unit and the Option 100 unit.

#### A-6 Suggestions for Using Appendix A

A-7 The Option 100 changes are listed sequentially, starting with Section I in the main body of the manual and working back through Section VII. It is recommended that the user mark all the necessary changes directly into his manual. This will update the manual for Option 100 and eliminate the need for constant referrals back to Appendix A.

#### A-8 Section I Manual Changes

A-9 In paragraph 1-11 change the output power from "200 Watts" to "150 Watts."

#### A-10 Specifications Changes

A-11 Table A-1 provides all the specifications changes for Option 100. Specifications not listed in Table A-1 are the same as those in the main specifications, Table 1-1.

### A-12 INSTALLATION

#### A-13 Section II Manual Changes

A-14 **Line Voltage Option Conversion.** In paragraph 2-26, c; jumper W1 is already soldered in place at the factory for 100 V operation. In paragraph 2-26, d; the 6A fuse is already installed for Option 100. It is possible to convert the Option 100

units to other line voltages by following the directions in paragraph 2-26, but the unit will maintain its derated 150 V, 50 V output.

**WARNING**

*No attempt should be made by the user to update the Option 100 unit above its calibrated output voltage and power limits. To do so could result in severe damage to the unit and a fire hazard.*

### A-15 OPERATING INSTRUCTIONS

### A-16 Section III Manual Changes

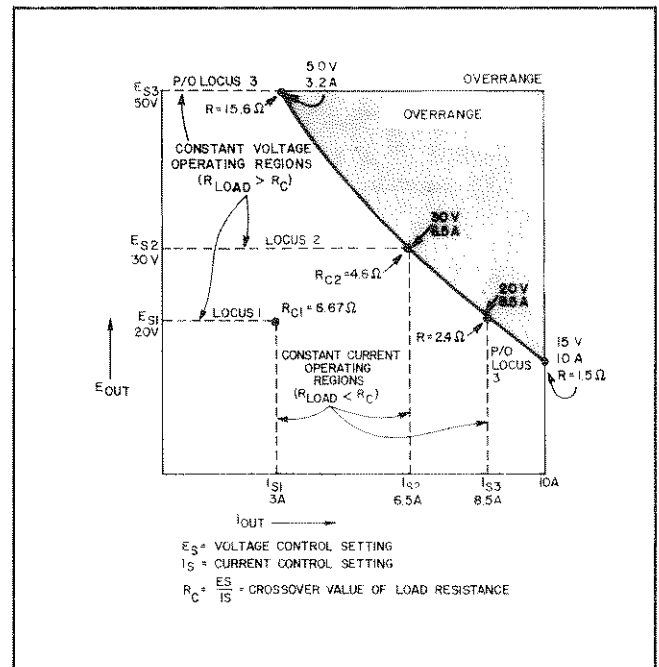

Figure A-1. Overall Output Range with Three Sample Operating Loci (Replaces Figure 3-2).

A-17 In paragraph 3-7 (which refers to Figure 3-2 in the manual) the reference illustration is now Figure A-1 instead of Figure 3-2. Also change "6.6  $\Omega$ " to "6.67  $\Omega$ ."

A-18 In paragraph 3-8 change "35 V" to "30 V" and "5.4  $\Omega$ " to "4.6  $\Omega$ ."

**Table A-1. Specifications and Supplemental Characteristics**

**DC Output:** Voltage and current can be programmed via HP-IB or front panel control over the following ranges:  
**Voltage:** 0-50 V **Current:** 0-10 A. See graph for maximum output power. (This power is available at load with up to 0.5 V drop in each load lead.)

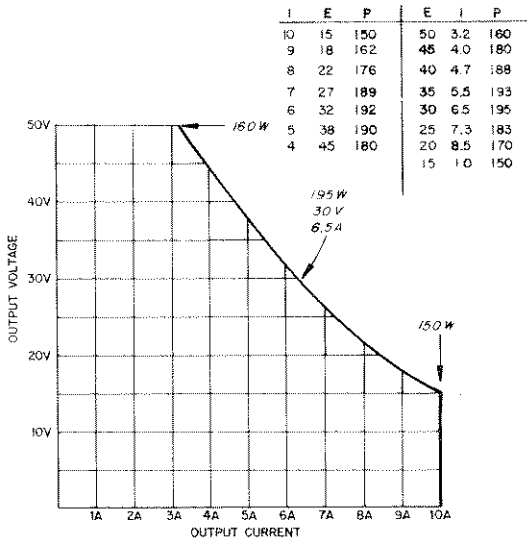

**Programming Resolution:** Voltage: 12.5 mV Current: 2.5 mA

**Programming Settability:** Voltage: 25 mV Current: 5.0 mA

**Programming Response Time:** Maximum time for output voltage to change from 0 to 50 V or 50 to 2 V and settle within a 60 mV band (0.116% of maximum rated output):

		60 mV (*)	15 mV (**)
Up:	Full Load (15.6Ω)	200 ms	225 ms
	No Load	200 ms	225ms
Down:	Full Load (15.6Ω)	300 ms	450 ms
	No Load	600 ms	750 ms

\*Max, \*\*Typical

Typical response time for excursions other than full scale can be calculated as follows:

**Up Programming:** On graph, read time for change in output voltage.

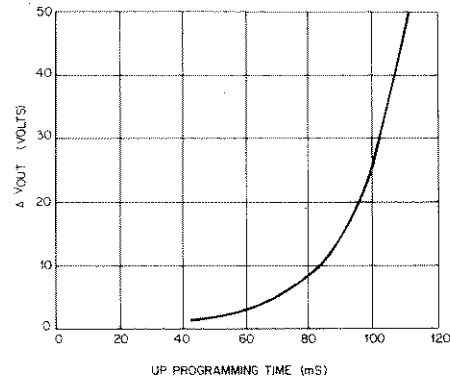

**Down Programming:** On graph, read difference in time between initial-output-voltage point and final-output-voltage point; add settling time of 125 ms if final voltage  $\geq 2$  V, or 500 ms if final voltage  $< 2$  V, to settle within 60 mV band.

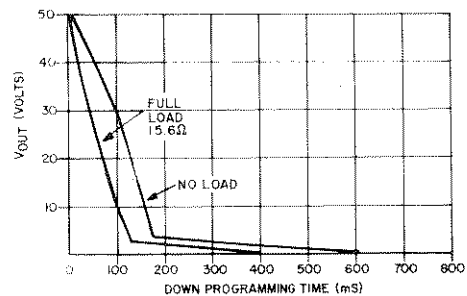

**Readback:** Output Voltage: Range: 0-50 V  
 Resolution: 12.5 mV  
 Accuracy:  $\pm 0.08\% \pm 35$  mV  
 Temperature Coefficient:  
 $\pm 0.07\% / ^\circ\text{C} \pm 0.35$  mV/  $^\circ\text{C}$

**Overvoltage Protection:** The lower of the two OVP trip points will dominate.

**Local OVP Adjustment:** Range 1.7 V to 54.5 V  
 Resolution: 0.20 V

**Remote OVP Adjustment:** Range: 2.0 V to 54.5 V (the OVP trip point = 2 V + 1.05 X soft voltage limit)  
 Resolution: 0.20 V

Accuracy:  $\pm 0.7$  V. The OVP circuit will trip when the voltage between the + output and the outboard side of the current monitoring resistor equals the set voltage. This could be as much as 1.35 V above the voltage between the + S and - S terminals.

A-19 In paragraph 3-10 change "11.9Ω" to "15.6Ω," "2.9Ω" to "2.4Ω" and "25 V" to "20 V."

A-20 In paragraphs 3-11 and 3-36 change "200 W" to "150 W."

A-21 In paragraph 3-15, b; 3-28, and 3-121 change "64.5 V" to "54.5 V."

A-22 In paragraph 3-25 change the third sentence to read: "The approximate trip voltage range is from two volts to 54.5 volts at Remote and 1.7 volts to 54.5 volts at Local."

A-23 In paragraphs 3-28 and 3-117 change "1.04" to "1.05."

A-24 In paragraph 3-28 change "33.2 V." to "33.5 V."

A-25 In paragraph 3-28 and 3-88 change "60 V" to "50 V."

A-26 In paragraph 3-79 change "60Ω" to "50Ω" to "120Ω" to "100Ω," and "30 W" to "25 W."

A-27 In Figure 3-13, Programming syntax, change "VOLTAGE" and "SOFT VOLTAGE" to "00.000 to 50.000 V."

A-28 In paragraphs 3-111 and 3-121 change "60.000" to "50.000."

## A-29 PRINCIPLES OF OPERATION

### A-30 Section IV Manual Changes

A-31 In paragraph 4-28, note that the 0-volt to 5-volt reference amplifier output given in paragraph 4-74 for the CC Circuit is attenuated to 0-volt to 4.17-volt for the CV Circuit.

A-32 In paragraph 4-74, the reference illustration is now Figure A-2 instead of Figure 4-6.

A-33 In paragraph 4-92, note that the input filter charges to approximately 250 volts dc.

## A-34 MAINTENANCE

### A-35 Section V Manual Changes

A-36 In paragraphs 5-9; and 5-34 f; change "2Ω" to "1.5Ω."

A-37 In paragraphs 5-9; 5-17, c; 5-34, b,e,f,h; 5-44, e; 5-48, f; 5-52, b; and 5-127, b; change "20 V" to "15 V."

A-38 In paragraph 5-9 change "18Ω" to "15.6Ω."

A-39 In paragraphs 5-9; 5-29, c; change "3.3 A;" to "3.2 A."

A-40 In paragraphs 5-9; 5-15, c,h; 5-19, e; 5-29, c; 5-38 c; 5-41, c; 5-46, d; 5-129, g,h; 5-132, f; and 5-136, g; change "60 V" to "50 V."

A-41 In paragraph 5-9 change "230 W" to "195 W."

A-42 In paragraph 5-15, d; change "60.0" to "50.0."

A-43 In paragraph 5-15, f; 5-19, g; 5-38, e; 5-41, e; and 5-46, b; change "33 mV" to "32 mV" and "3.3 A" to "3.2 A."

A-44 In paragraph 5-25, c; change "40 V and 5.7 A" to "30 V and 6.5 A."

A-45 In paragraph 5-34, c; change "2.22Ω" to "1.66Ω."

A-46 In paragraph 5-34, f; change "20.2Ω" to "15.56Ω."

A-47 In paragraph 5-38, j; change "70 mVdc" to "60 mVdc."

A-48 In paragraph 5-41, h; change "21 mVdc" to "18 mVdc."

A-49 In Table 5-2, under "OVP TEST", numbers 3 and 5, change "64.5" to "54.5."

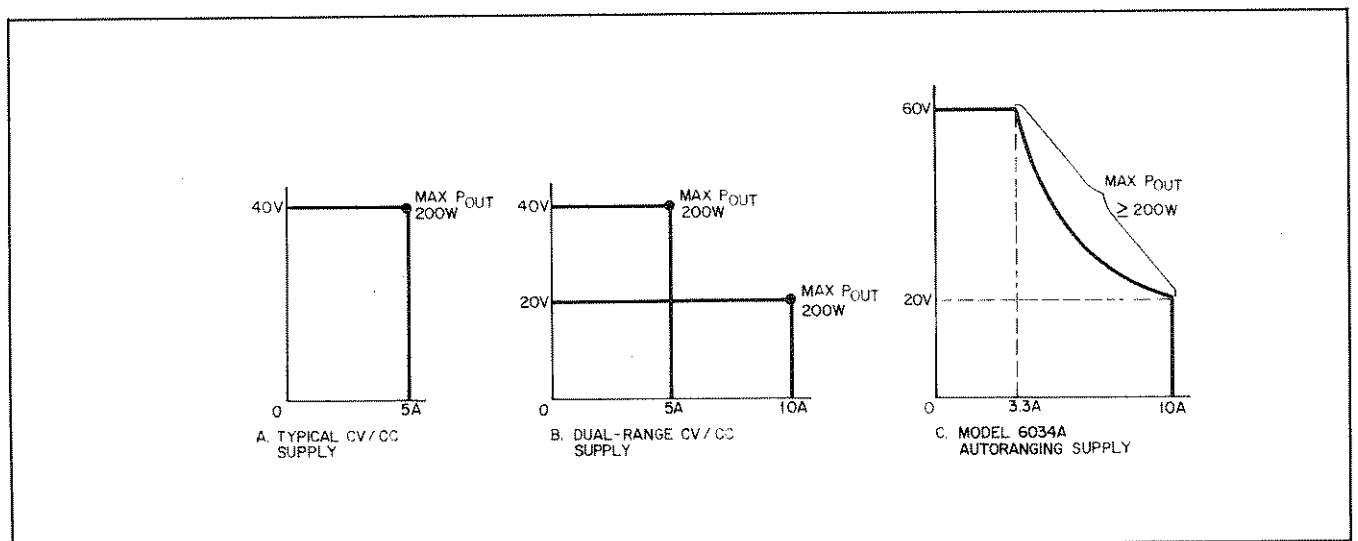

Figure A-2. Output Characteristics: Typical, Dual-Range, and Autoranging Supplies

A-50 In paragraph 5-69, b; WARNING; and 5-132, NOTE; change "60" to "50."

A-51 In Figures 5-12 and 5-15, the signature at A3U9-3 should be 0000.

A-52 On Figure 5-16, sheet 2, block 4, change 0-60 volts to 0-50 volts; blocks 19 and 23, change 0 to 5 volts to 0 to 4.17 volts. On Figure 5-16, sheet 7, block 2, change "U60 V GR" in each program to "U50V GR".

A-53 On Figure 5-27, block 7, change 60 volts to 50 volts.

A-54 On Figure 5-35, block 1, the remotely programmed OVP level is  $2\text{ V} + 1.05$  times the soft voltage limit.

A-55 On Figure 5-36, block 1, change "P60 V U20 V G" in each program to "P50V U20 V G". In block 3, change "U60 V GR" in each program to "U50 V GR".

A-56 In paragraph 5-124, c; change "+ 6.45 V" to "+ 5.45 V."

A-57 In paragraph 5-126, f; change "+ 24 V" to "+ 19 V."

A-58 In paragraph 5-126, k,m; change "+ 23 V" to "+ 17.5 V."

A-59 In paragraph 5-127, b; change "P20V..." to "P15V..."

A-60 In paragraphs 5-129, g; 5-132 f; and 5-136, g; change "P60V..." to "P50V..."

A-61 In paragraph 5-135, e; change "22.5 mV" to "18.5 mV."

A-62 In paragraph 5-135, g; change "NV00.015" to "NV00.012."

A-63 In paragraph 5-136, h; change "54.0075 V" to "44.0063 V."

A-64 In paragraph 5-136, j; change "NV54.000" to "NV44.000."

## **A-65 REPLACEABLE PARTS/SCHEMATIC DIAGRAMS**

### **A-66 Section VI and VII Manual Changes**

A-67 In the replaceable parts list and on the schematic diagram for the Front Panel Assembly A3, change:

R16 to 0698-8184	7.5k
R38 to 0757-0472	200k
R41 to 0698-0084	2.15k
R71 to 0698-6609	75k
R72 to 0698-6276	12.5k
R153 to a jumper wire	

## Appendix B LOGIC SYMBOLY

The logic symbols used in this manual are based on the American National Standard Institute (ANSI) Y32.14 and current discussions in the Institute of Electrical and Electronic Engineers (IEEE) and the International Electrotechnical Commission (IEC). The following paragraphs and illustrations provide a brief description of the symbology to aid in interpreting the symbols. When referring to the symbols, it should be remembered that:

1. Power supply and ground connections usually are not shown on the symbols, but are listed separately on the schematic.
2. Items in brackets [ ] are not part of the symbol, but are included to help the user interpret the symbol.
3. Unless arrows indicate otherwise, inputs are on left, outputs are on right, and signal flow is from left to right.
4. In an array of two or more identical elements, only the first (top) element is shown in full detail.
5. When shown individually on a schematic rather than as part of an array, basic logic gates (AND, OR, buffer) are shown by distinctive-shape outlines (see Figure B-1).

**Qualifier and Functional Labels.** Figure B-2 shows qualifiers and functional labels. Qualifiers denote basic logic functions. For example, "∑" denotes the AND function. Functional labels, such as DEMUX for a demultiplexer, identify complex devices.

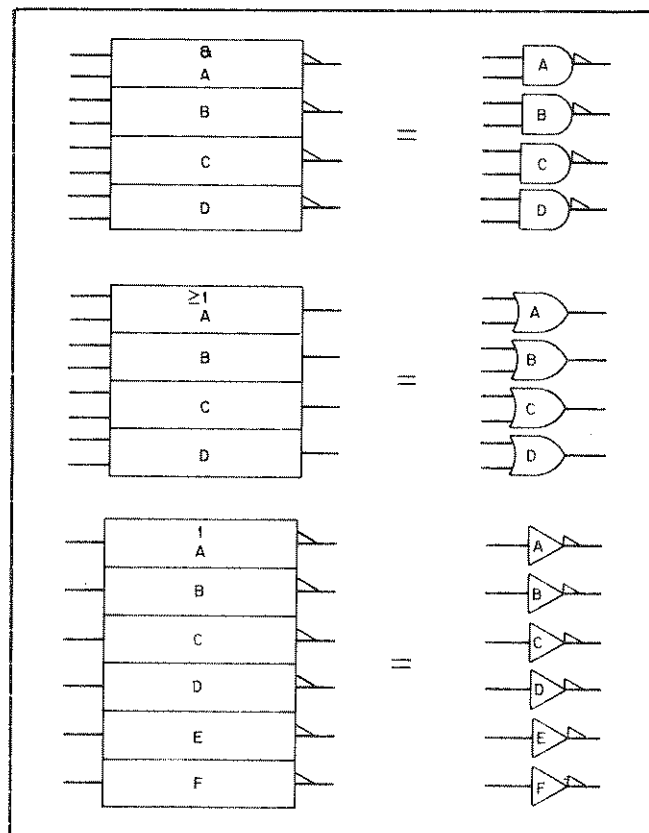

Figure B-1. Distinctive-Shape Outlines

FF	<b>Flip-Flop</b> - Binary element with two states, set and reset. When the flip-flop is set, its outputs will be in their active states. When the flip-flop is reset, its outputs will be in their inactive states.	MUX	<b>Multiplexer</b> - The output is dependent only on the selected input.
$\&$	<b>AND</b> - All inputs must be active for the output to be active.	DEMUX	<b>Demultiplexer</b> - Only the selected output is a function of the input.
$\geq 1$	<b>OR</b> - One or more inputs being active will cause the output to be active.	REG	<b>Register</b> - Array of unconnected flip-flops that form a simple register or latch.
$\equiv 1$	<b>EXCLUSIVE OR</b> - Output will be active when one (and only one) input is active.	SRG*	<b>Shift Register</b> - Register in which data can be shifted from one stage to the next, the asterisk indicates the number of stages.
1	<b>Buffer or Inverter</b> - Without special amplification.	COMP	<b>Comparator</b> - The active output indicates which of two or more sets of inputs is of greatest magnitude.
$\equiv m$	<b>m and only m</b> - Output will be active when m (and only m) inputs are active (m is replaced with a number).	$1\text{JL}$	<b>Monstable (One-Shot) Multivibrator</b> - Output becomes active when the input becomes active. Output remains active (even if the input becomes inactive) for a period of time that is characteristic of the device and/or circuit.
$\equiv$	<b>Logic Identity</b> - Output will be active only when all or none of the inputs are active (i.e., when all inputs are identical, output will be active).	BIN/OCT	<b>Binary-to-Octal Decoder</b> - Converts a three-line binary code to eight-line octal code.
	<b>Amplifier</b> - The output will be active only when the input is active (can be used with polarity or logic indicator at input or output to signify inversion).	HPRI/BIN	<b>High-Priority-to-Binary Encoder</b> - Encodes the address of the highest active of eight inputs to three-line binary code.
X/Y	<b>Signal Level Converter or Code Converter</b> - Input level(s) are different than output level(s), or input code (X) is converted to output code (Y) per weighted values or table.	$\#/\cap$	<b>Digital-to-Analog Converter</b> - Output current is a linear product of a digital word.
CTR	<b>Counter</b> - Produces one output pulse each time it receives a specific number of input pulses.	RAM	<b>Random Access Memory</b> - Addressable memory with read-in and read-out capability.
		ROM	<b>Read Only Memory</b> - Addressable memory with read-out capability only.
		EPROM	<b>Erasable Programmable Read Only Memory</b> - Similar to a ROM in normal use, but can be erased and programmed with special equipment.

Figure B-2. Qualifiers and Functional Labels



**Indicator Symbols.** Indicator symbols identify the active state of a device's input or output, as shown in Figure B-3.













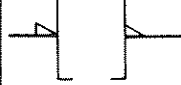
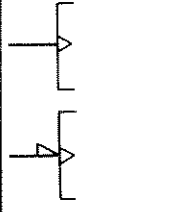

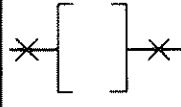



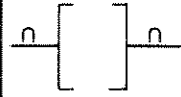

	<b>Implied Indicator</b> - Absence of polarity indicator (see below) implies that the active state is a relative high voltage level.		<b>Shift Right (Down) Input</b> - When active, causes the contents of a shift register to shift to the right or down "m" places (m is replaced with a number).
	<b>Polarity Indicator</b> - The active state is a relatively low voltage level.	<b>NOTE</b> <i>If m = 1, it is omitted.</i>	
	<b>Dynamic Indicator</b> - The active state is a transition from a relative low to a relative high voltage level, or from a high to a low voltage level if a polarity indicator is shown outside symbol.		<b>Postponed Output</b> - Output delayed until input returns to its initial state.
	<b>Non-Logic Indicator</b> - Input or output does not carry logic information (e.g., RC inputs to a one-shot multivibrator).		<b>Three-State Output</b> - Indicates outputs that can have a high-impedance (disconnect) state in addition to the normal binary logic states.
	<b>Open-Circuit Output, general symbol</b>		<b>Bithreshold Input</b> - Input characterized by hysteresis; one threshold for positive-going signals and a different threshold for negative-going signals.
	<b>Open-Circuit Output, H Level</b> - NPN open emitter, PNP open collector, P-channel FET open drain, N-channel FET open source.		<b>Greater-Than</b> Input or Output of a magnitude comparator.
	<b>Open-Circuit Output, L Level</b> - NPN open collector, PNP open emitter, P-channel FET open source, N-channel FET open drain.		<b>Less-Than</b> Input or Output of a magnitude comparator.
	<b>Analog Input or Output</b> - Used only when necessary to distinguish analog signals.		<b>Equal Input or Output</b> of a magnitude comparator.
	<b>Digital Input or Output</b> - Used only when necessary to distinguish digital signals.		<b>Extension Input or Extender Output</b> - Connected between devices to extend the number of inputs.
	<b>Data Input</b> - Always enabled by another input (generally a C input-see Dependency Notation). Any D input is associated with storage.		<b>Multiplier Input</b> - Analog input used to control a variable characteristic of a function (e.g., range).
			<b>Content</b> - Indicates the value of an input or output when active.
			<b>Binary Grouping</b> - m is highest power of 2.
			<b>Input Line Grouping</b> - Two or more terminals implement a single logic input.

Figure B-3. Input and Output Indicators

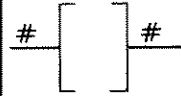
**Contiguous Blocks.** Two symbols may share a common boundary parallel or perpendicular to the direction of signal flow. Note that in the examples shown in Figure B-4 there is generally no logic connection across a horizontal line, but there is always

an implied logic connection across a vertical line. Notable exceptions to this rule are the horizontal lines beneath control blocks and between sections of shift registers and counters.

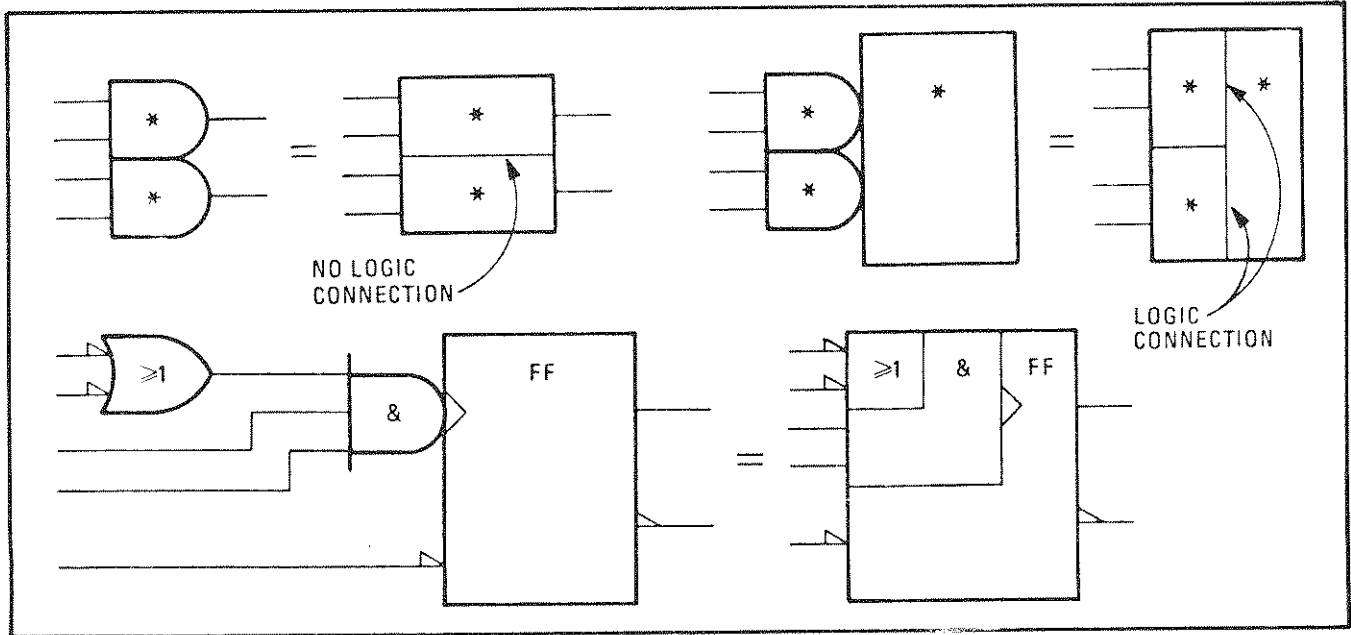

Figure B-4. Contiguous Blocks

**Common Control Block.** The Control block is used in conjunction with an array of related symbols in order to group common logic lines. Figure B-5 shows how the Control block is usually represented. Figure B-6 shows a quad D-type flip-flop with reset. This can be redrawn as shown in Figure B-7. Note that the more complex representation shown in Figure B-6 can be used when the flip-flops are functionally scattered around the schematic (i.e., not used as a quad unit).

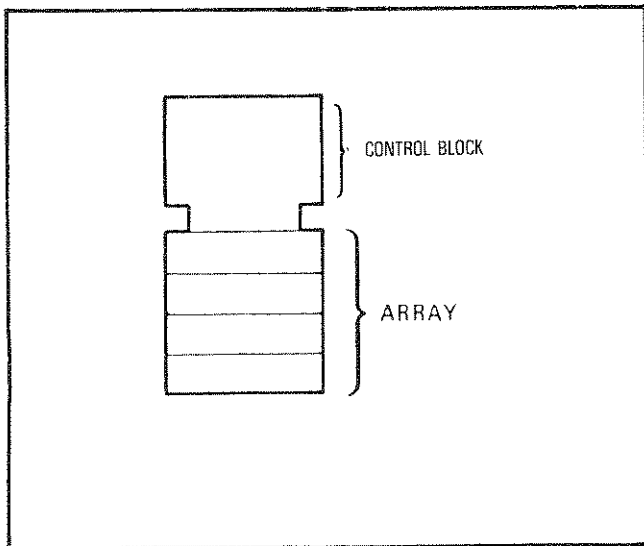

Figure B-5. Common Control Block

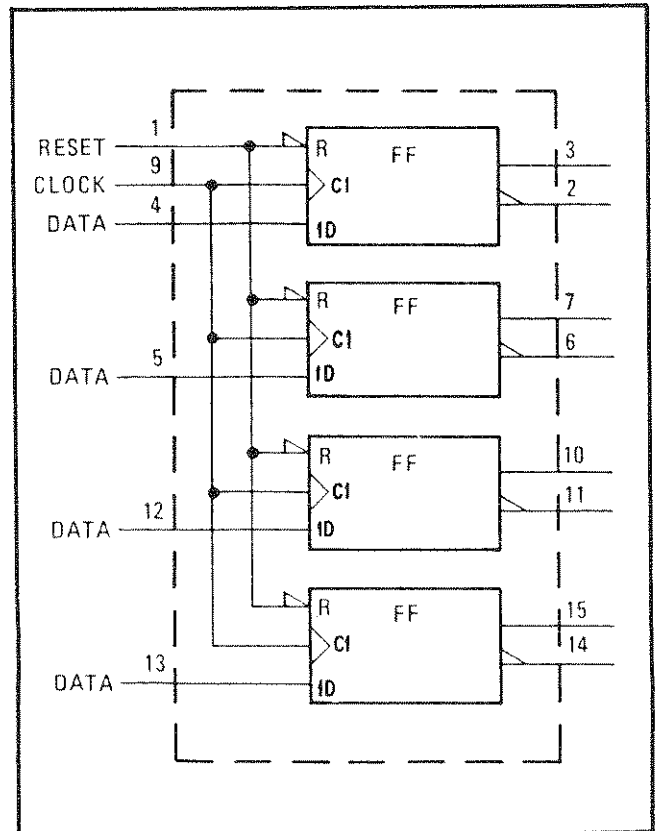

Figure B-6. Quad D-Type Latch (Individual)

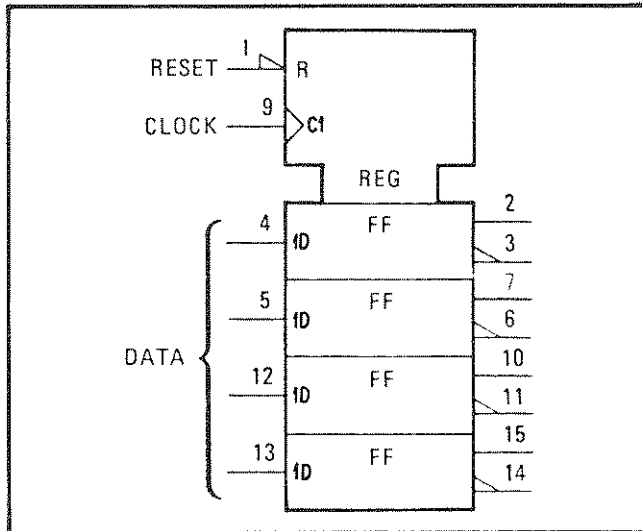

Figure B-7. Quad D-Type Latch (Combined)

**Dependency Notation.** Dependency notation simplifies symbols for complex integrated circuit elements by defining the interdependencies of inputs or outputs without actually showing all the elements and interconnections involved. (See Figure B-8 and B-9 for examples of AND dependency and enable dependency.)

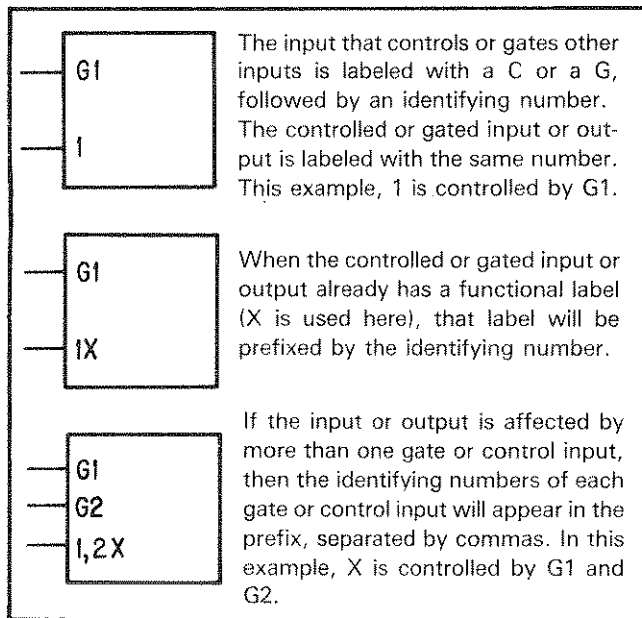

Figure B-8. AND Dependency Notation

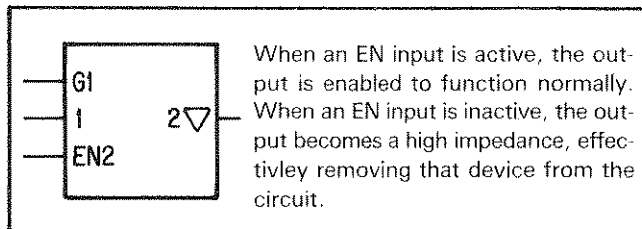

Figure B-9. Enable Dependency Notation

Application of dependency notation is accomplished by:

1. labelling the input affecting other inputs or outputs with the letter symbol denoting the relationship involved followed by an appropriately chosen identifying number, and
2. labelling each input or output affected by the affecting input with that same number.

If it is the complement of the internal logic state of the affecting input or output that does the affecting, a bar is placed over the identifying number at the affected input or output.

If the affected input or output requires a label to denote its function, this label shall be prefixed by the identifying number of the affecting input.

If an input or output is affected by more than one affecting input, the identifying numbers of each of the affecting inputs shall appear in the label of the affected one separated by commas. The left-to-right reading order of these identifying numbers is the same as the sequence of the affecting relationships.

Two affecting inputs labelled with different letters shall not have the same identifying number, unless one of the letters is A.

If two affecting inputs have the same letter and the same identifying number, they stand in an OR relationship to each other.

If the labels denoting the functions of affecting inputs or outputs must be numbers (e.g., outputs of a coder), the identifying numbers to be associated with both affecting inputs and affected inputs or outputs shall be replaced by another character selected to avoid ambiguity (e.g., Greek letters).

An affecting input affects only the corresponding affected inputs and outputs of the symbol.

Note that dependency notation is usually indicated by numbers. The numbers themselves have no value; they simply relate two or more points having the same number. However, sometimes an input or output has a weighted value (e.g., 1,2,4,8); in these cases a non-numeric symbol (e.g.,  $\times$ ) may be used to avoid confusion between a weighted value and the dependency notation.

Eleven types of dependencies are defined, as listed below:

- A **Address** - Identifies the address inputs of a memory.
- C **Control** - Identifies an input, such as a timing or clock input, that produces action, and indicates which other inputs are controlled by it. Used for sequential elements (flip-flops, registers), and may imply more than a simple AND relationship.
- EN **Enable** - Identifies an input that enables outputs, and indicates which outputs are affected by it. Acts as a connect switch when active, and a disconnect switch when inactive.

- G **Gate (AND)**- Identifies an input having an AND relationship with other inputs or outputs having the same identifier number (or symbol).
- M **Mode** - Identifies an input that selects the mode of operation, and indicates which inputs and outputs depend on that mode.
- N **Negate** - Identifies an input that when active, complements other inputs or outputs, and identifies which inputs and outputs are affected.
- R **Reset** - When active, causes a flip-flop to reset.
- S **Set** - When active, causes a flip-flop to set.
- V **OR** - Identifies an input having an OR relationship with other inputs or outputs having the same identifier number (or symbol).
- X **Transmission** - Identifies an input that makes or breaks bidirectional connections between affected input/output ports.
- Z **Interconnection** - Identifies a point that is internally connected to another input, output, internal input, or internal output having the same identifier number (or symbol).

**Connections to Discrete Components.** Discrete components that are a functional part of the logic device connect to pins marked as shown in Figure B-10.

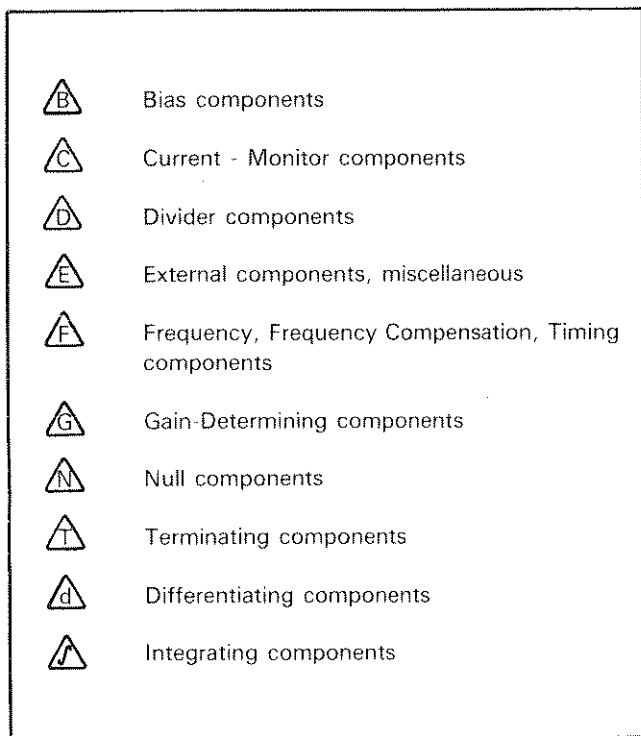

Figure B-10. Connections to Discrete Components

**Miscellaneous Terms and Symbols.** Figure B-11 shows miscellaneous terms and symbols that are used in conjunction with the logic symbols, function tables, and truth tables used in this section.

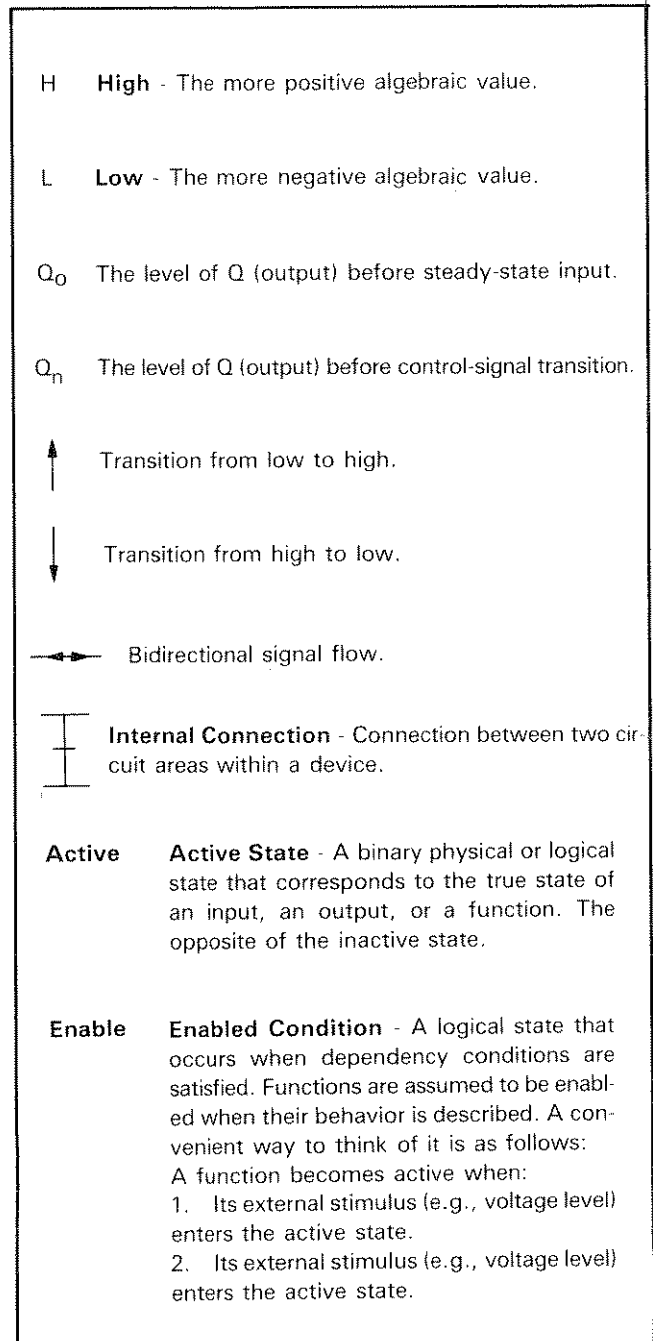
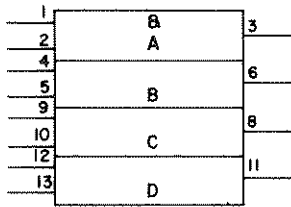

Figure B-11. Miscellaneous Terms and Symbols

**Basic Logic Symbols.** Figure B-12 shows the symbols for each of the basic logic devices used in this instrument. Also included are the HP part number, the part number of the device from a typical manufacturer, and the reference designators for each use of the device in this instrument.

Quad 2-Input AND Gate  
1820-1201 T.I. SN74LS08N

Vcc pin 14 Gnd pin 7



A4U20  
A4U47  
A4U75

Quad 2-Input NAND Gate  
1820-1197 T.I. SN74LS00N

Vcc pin 14 Gnd pin 7

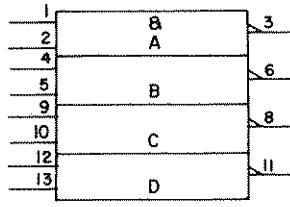

A4U44

Quad 2-Input NAND Gate  
with Open-Collector Output  
1820-1209 T.I. SN74LS38N

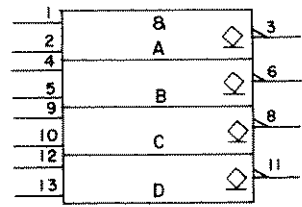

A2U8

Dual 4-Input NAND Gate  
1820-1204 T.I. SN74LS20N

Vcc pin 14 Gnd pin 7

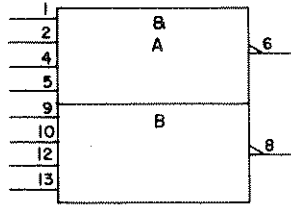

A4U42

Triple 3-Input AND Gate  
1820-1203 T.I. SN74LS11N

Vcc pin 14 Gnd pin 7

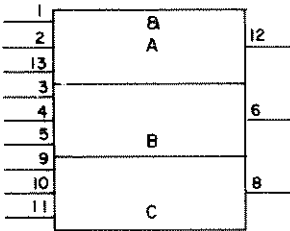

A4U45  
A4U77

8-Input NAND Gate  
1820-1207 T.I. SN74LS30N

Vcc pin 14 Gnd pin 7

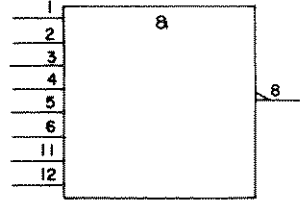

A4U28  
A4U65

Quad 2-Input OR Gate  
1820-1208 T.I. SN74LS32N

Vcc pin 14 Gnd pin 7

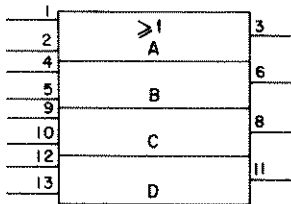

A4U3  
A4U11  
A4U13  
A4U69  
A4U76

Quad 2-Input NOR Gate  
1820-1144 T.I. SN74LS02N

Vcc pin 14 Gnd pin 7

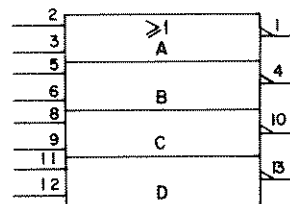

A4U2

Dual 2-input NOR Driver  
with Open-Collector Output  
1820-1050 T.I. SN75454BP

Vcc pin 8 Gnd pin 4

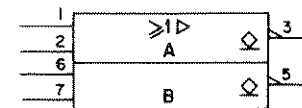

A1U2  
A1U12

Figure B-12. Basic Logic Device Symbols

Quad 2-Input Exclusive OR Gate  
 1820-1211 T.I. SN74LS86N  
 Vcc pin 14 Gnd pin 7

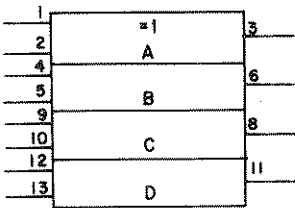

A4U63

Hex Inverter  
 1820-1199 T.I. SN74LS04N  
 Vcc pin 14 Gnd pin 7

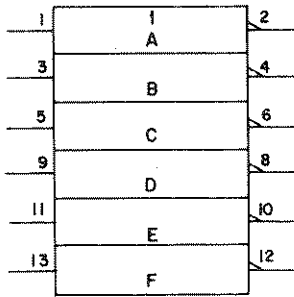

A4U21  
 A4U26  
 A4U46  
 A4U64  
 A4U71  
 A4U84

Quad Bus Buffer with 3-State Output  
 1820-1568 T.I. SN74LS125N  
 Vcc pin 14 Gnd pin 7

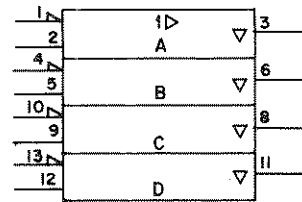

A4U36  
 A4U79

Optocoupler 1990-0429  
 Vcc pin 8 Gnd pin 5

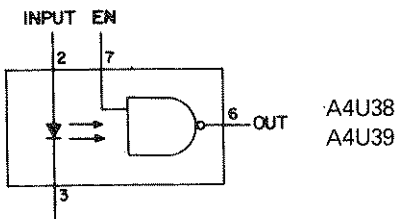

Truth Table

Input	Enable	Output
1	1	0
1	0	1
0	1	1
0	0	1

Optocoupler  
 1990-0593

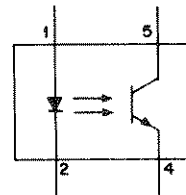

A4U37  
 A4U53  
 A4U88  
 A4U89  
 A4U91

Figure B-12. Basic Logic Device Symbols (cont.)

**D-Type Flip Flop.** D-type flip flops are used for temporary storage of one bit of binary data. Figures B13 through B-16 show four varieties of D-type flip flops. In each, the D input is stored and transferred to the output when the control input, C, goes from low to high. The C input in Figure B-16 is gated

by a low level at the G input. Note that Figure B-13 contains two identical flip flops, each with its own control, set, and reset inputs, while the others have common control inputs. The flip flops in Figures B-13 and B-14 have inverting as well as non-inverting outputs.

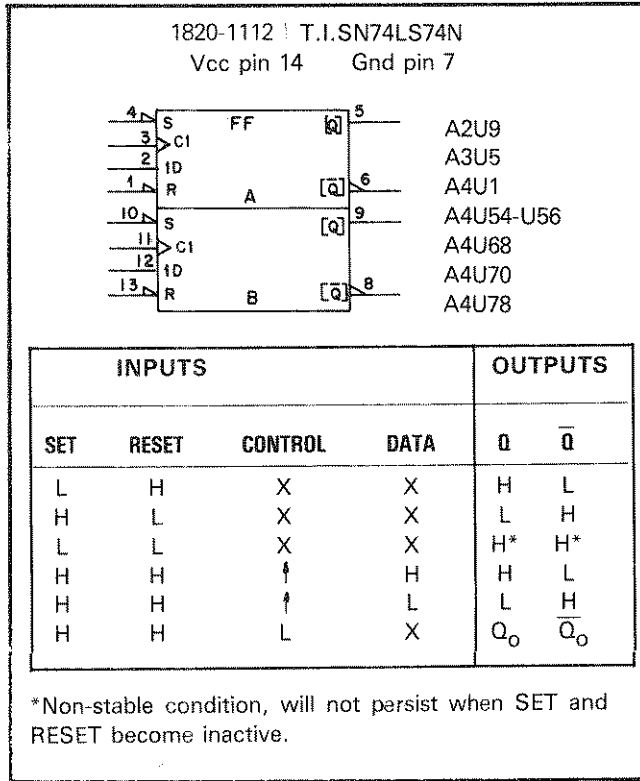

Figure B-13. Dual D-Type Flip Flop

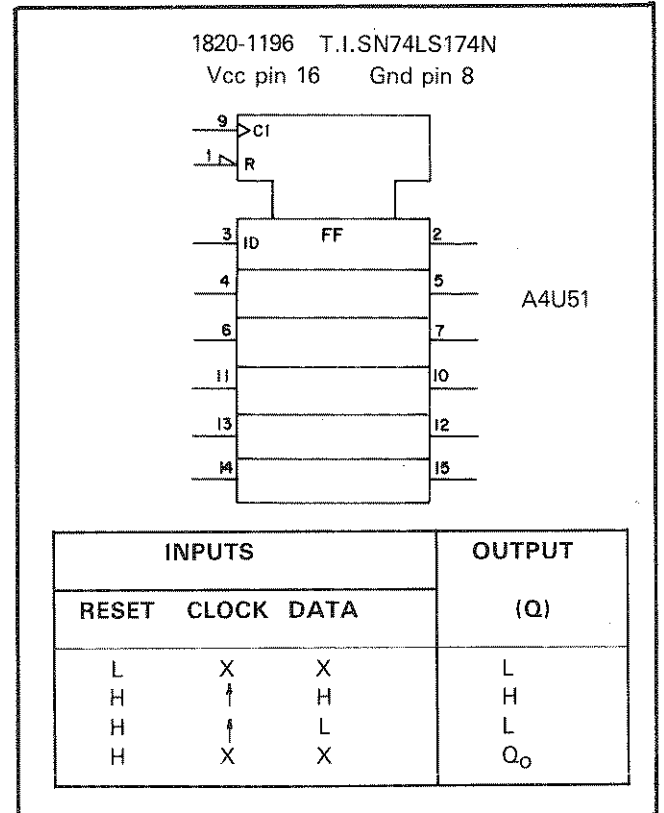

Figure B-15. Hex D-Type Flip Flop

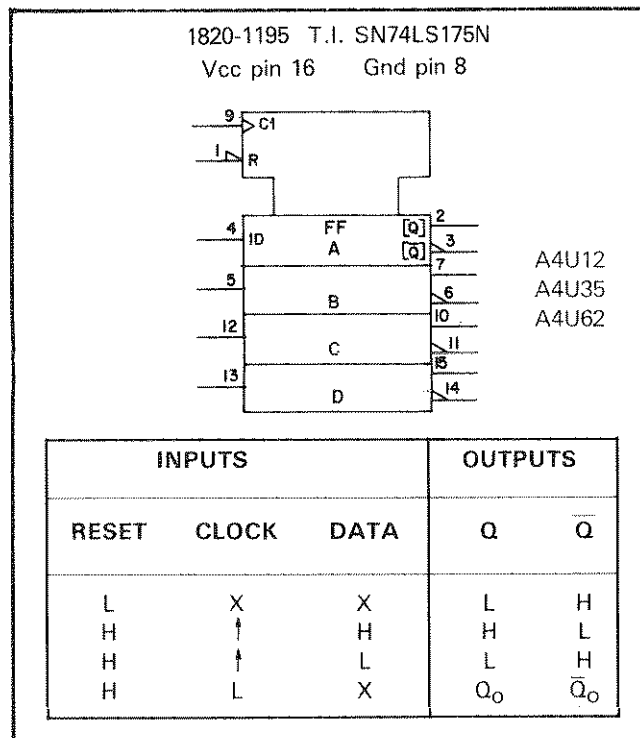

Figure B-14. Quad D-Type Flip Flop

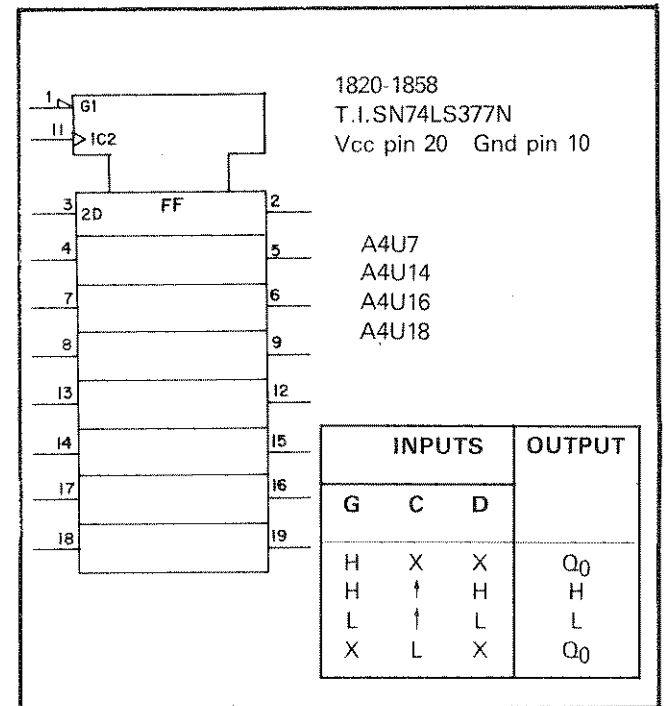

Figure B-16. Octal D-Type Flip Flop

**J-K Flip-Flop.** J-K flip-flops have two conditioning inputs, J and K, which determine the state the flip-flop assumes upon receipt of a positive-going clock pulse, C. In Figure B-17 the J input is active high and the K input is active low.

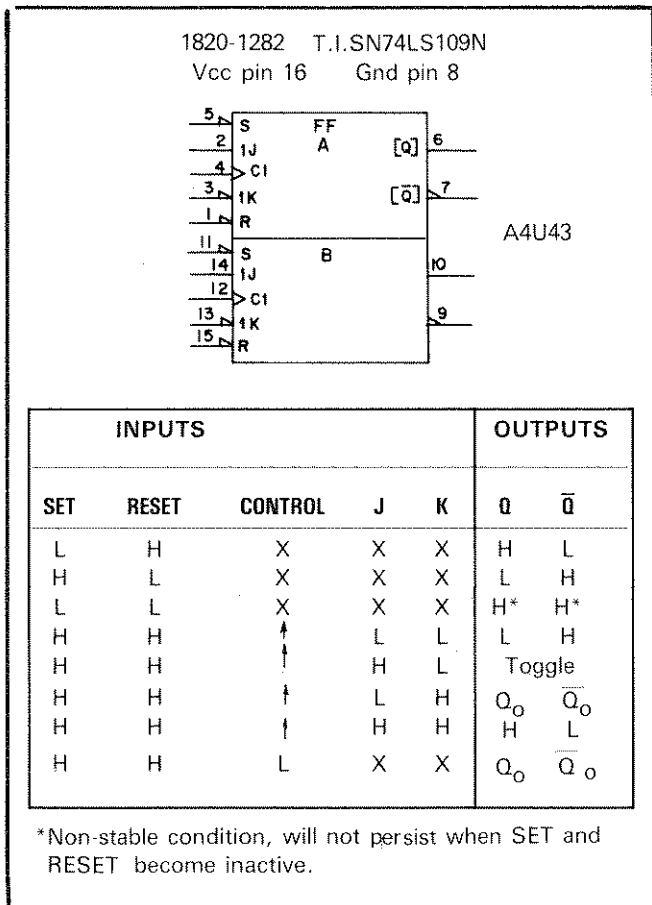

Figure B-17. Dual J-K Flip-Flop

**Shift Register.** Figure B-18 shows a four-bit shift register. In mode 1, data is parallel loaded into the four registers (pins 3,4,5,6) when the C input is low. In mode 2, data is serial loaded into the first register (pin 2) when the C input is low. Note that the C input also shifts data from the first register to the second, etc. when in mode 2 (2→ indicates that the shift function is dependent on mode 2). When enable is inactive (high), 3-state outputs are high impedance, but sequential operation of the registers and the output at pin 11 (cascade output) are not affected.

**Binary Counter.** Figure B-19 shows a four-bit binary counter consisting of a divide-by-two section and a divide-by-eight section. When both inputs to the control block are active, the content of both sections equals zero. If the output of the divide-by-two section is connected to the input of the divide-by-eight section, the device operates as a divide-by-16 counter.

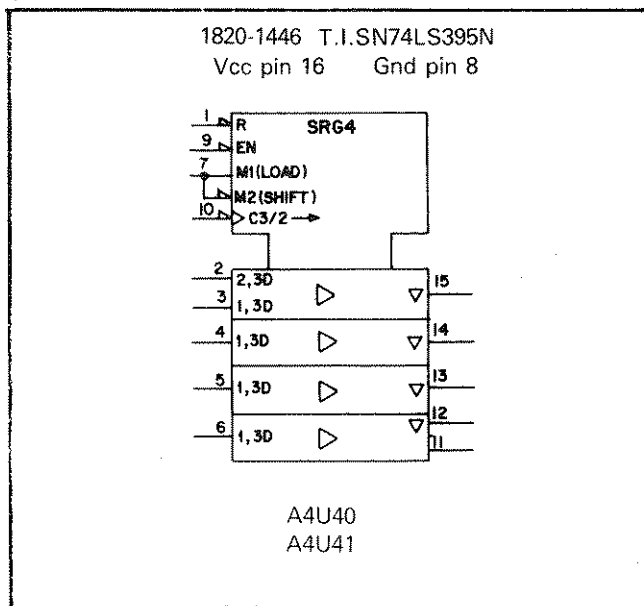

Figure B-18. Shift Register

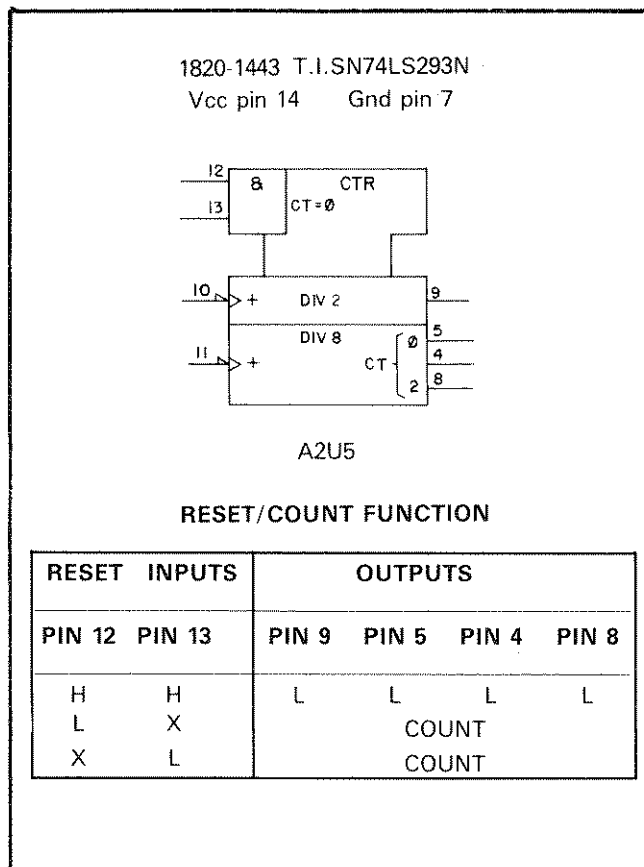

Figure B-19. Binary Counter



**Addressable Latch.** Figure B-20 shows an eight-bit addressable latch. The mode inputs (M) determine which latch is loaded when the G input is active. Data enters via the Z9 input, and is internally connected to the addressed latch. For example, consider the first latch. 9,0D indicates that data (D) from Z9 is loaded when in mode 0. 10,0R indicates that reset (R) from Z10 resets the latch when not in mode 0.

Reset can only operate on a latch when that latch is not addressed. Note that device may be in another mode (G8 active but mode 0 not active), in which case device operates as a demultiplexer (only the addressed latch is not reset), or G8 may be active (no latches can be addressed), in which case latches reset together.

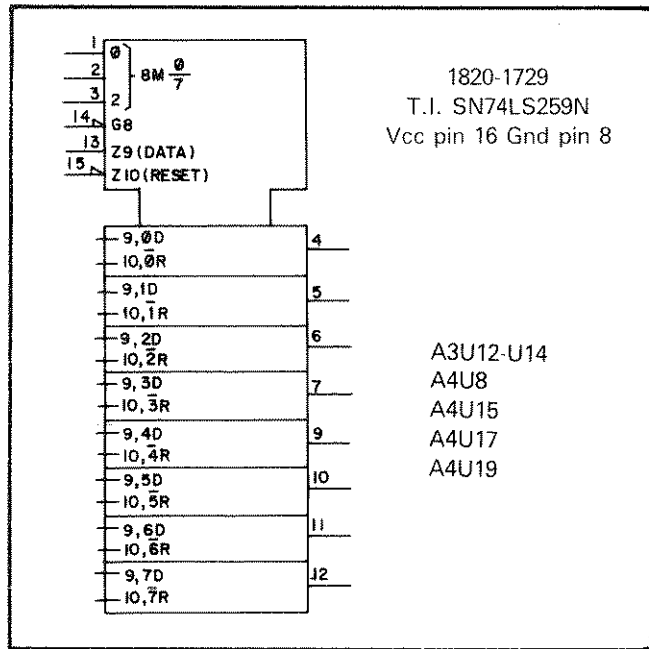

Figure B-20. Addressable Latch

**Magnitude Comparator.** A magnitude comparator compares two sets of digital data. Figure B-21 shows a four-bit magnitude comparator. If the cascade input  $P < Q$  is active, the cascade output  $P < Q$  is active. If the  $P > Q$  input is active, the  $P > Q$  output is active. If the  $P = Q$  input is active, the P and Q inputs determine which output is active.

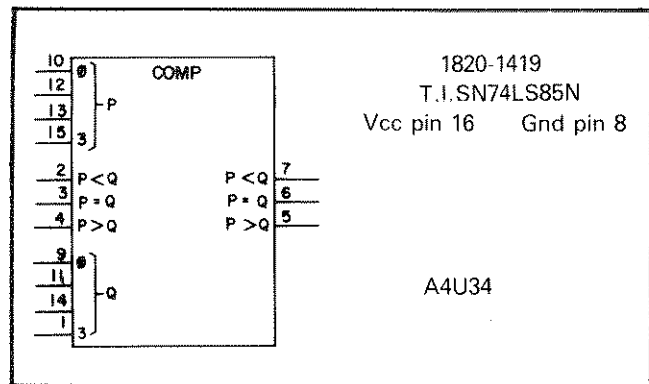

Figure B-21. Magnitude Comparator

**Data Selector/Multiplexer.** Figure B-22 shows a data selector/multiplexer. The three input lines that comprise G determine which of the eight data input lines is connected to the complementary outputs.

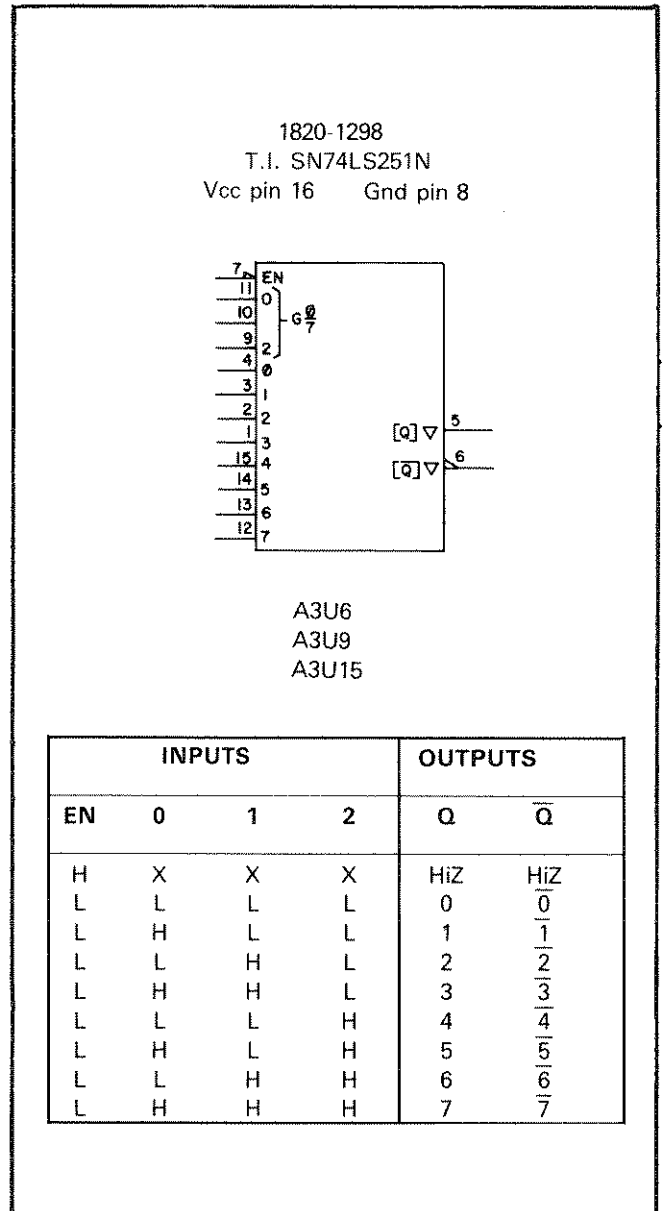
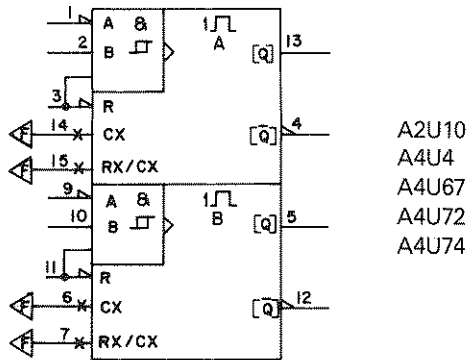

Figure B-22. Data Selector/Multiplexer

**Monostable (One-Shot) Multivibrator.** The one-shot multivibrator, when triggered, produces a pulse whose length is determined by an external RC circuit. The one-shot in Figure B-23 can be triggered by a negative-going transition at input A when both input B and reset are high or by a positive-going transition at input B when input A is low and reset is high. This device can also be triggered by a positive-going transition at reset. The external timing components are connected to the RX and RX/CX inputs.

1820-1437  
 T.I.SN74LS221N  
 Vcc pin 16 Gnd pin 8



INPUTS			OUTPUTS	
Reset	A	B	Q	$\bar{Q}$
L	X	X	L	H
X	H	X	L	H
X	X	L	L	H
H	L	↑		
H	↓	H		
↑*	L	H		

\*Either A or B input must be inactive when RESET goes low, both A and B inputs must then be active when RESET goes high.

Figure B-23. Monstable Multivibrator

**Three-to-Eight Line Decoder.** The device shown in Figure B-24 selects one of eight output lines corresponding to the value of the binary input. All three inputs to the enable block must be active for the output to be active.

1820-1216  
 T.I.SN74LS138N  
 Vcc pin Gnd pin 8

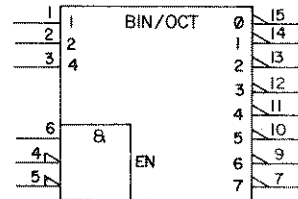

A4U29, U30

Figure B-24. Three-to-Eight Line Decoder

1820-1851  
T.I. SN74LS148  
Vcc pin 16 Gnd pin 8

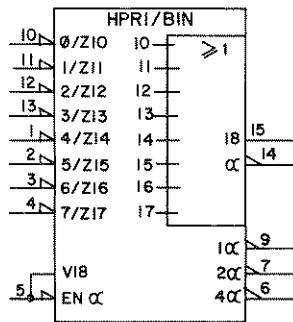

A4U52

Inputs													Outputs	
V18	EN $\alpha$	0	1	2	3	4	5	6	7	4	2	1	pin15	pin14
L	H	X	X	X	X	X	X	X	X	H	H	H	H	H
H	L	H	H	H	H	H	H	H	H	H	H	H	L	H
H	L	X	X	X	X	X	X	X	L	L	L	L	H	L
H	L	X	X	X	X	X	X	L	H	L	L	H	H	L
H	L	X	X	X	X	L	H	H	H	L	H	H	H	L
H	L	X	X	X	L	H	H	H	H	H	L	L	H	L
H	L	X	X	L	H	H	H	H	H	H	L	H	H	L
H	L	X	L	H	H	H	H	H	H	H	L	L	H	L
H	L	L	H	H	H	H	H	H	H	H	H	H	H	L

Figure B-25. Highest Priority to Binary Encoder

**Priority Encoder.** Figure B-25 shows a highest priority to binary encoder. The three-line binary output indicates the line number of the highest priority active input. V18 indicates that the pin 5 input has an OR relationship with the output marked 18. Therefore, if any of the eight input lines are active (low) or if pin 5 is high, the output at pin 15 will be active (high). The output at pin 14, which can be used to cascade devices, and the binary outputs are enabled by a low at pin 5. The alpha symbol ( $\alpha$ ) is used instead of a number to avoid confusion with the weighted values of the binary outputs.

**Bus Driver.** The bus driver shown in Figure B-26 contains six three-state drivers, four of which have one enable input, and two of which have a separate enable input.

**Random Access Memory (RAM).** Figure B-27 shows a 256 word static memory. Each word is four bits in length and is addressed via the address lines. Figure B-28 shows a similar RAM with a capacity of 1024 words. The G1 input must be low to enable the device, either read or write. C2 (active low) is the

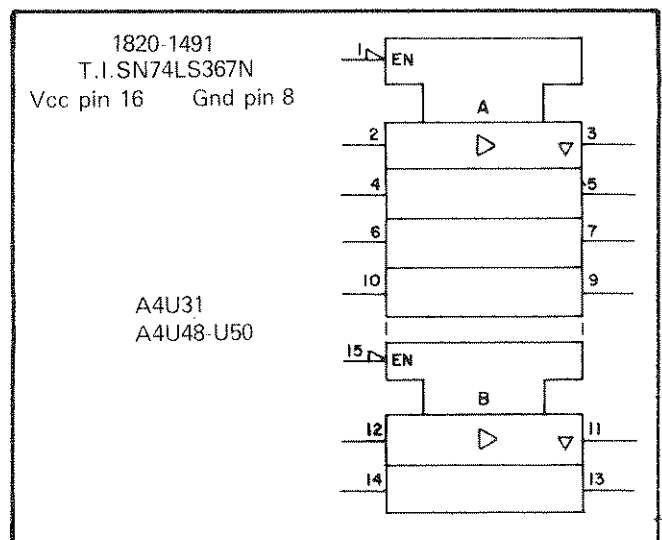

A4U31  
A4U48-U50

Figure B-26. Bus Driver

control signal that allows data (D) to be written into the addressed location. EN (active high) is the enable for the three-state outputs. The addressed output (on the right) is internally connected to the I/O pins on the left.

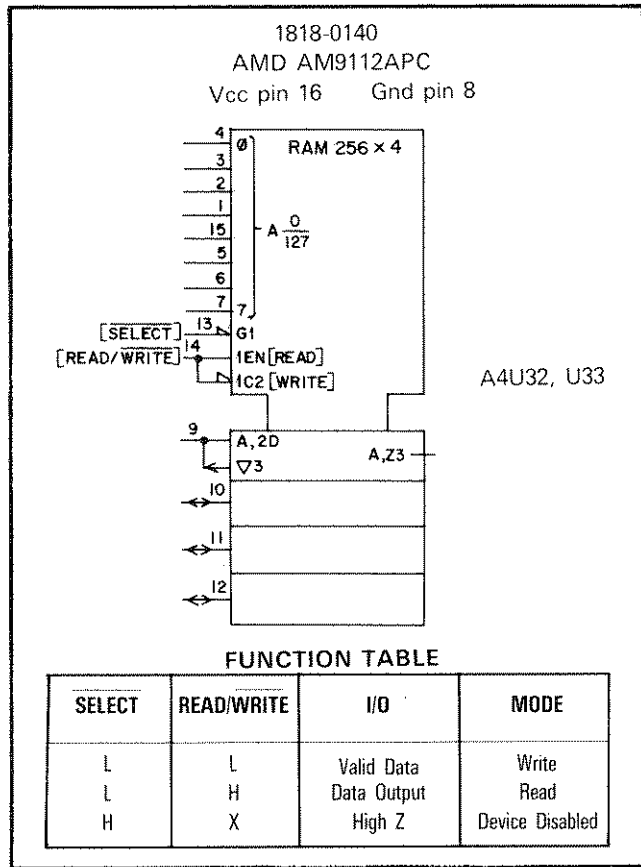

Figure B-27. 256 x 4-bit RAM

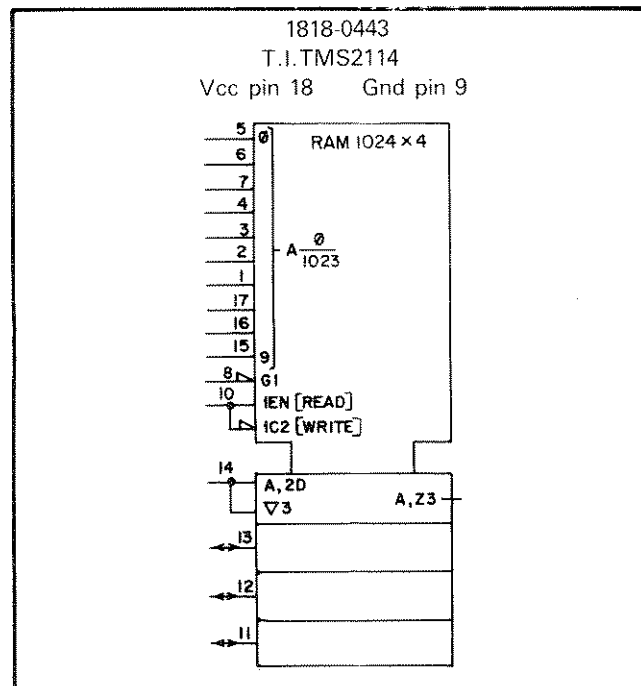

Figure B-28. 1024 x 4-bit RAM

**Read Only Memory (ROM).** Figure B-29 shows a ROM with 8-bit word length and 8192 addressable memory locations. Figure B-30 shows an erasable programmable read only memory (EPROM) with 2048 memory locations. Each device has three-state outputs controlled by an enable input. The EPROM has an additional bias voltage input used for programming.

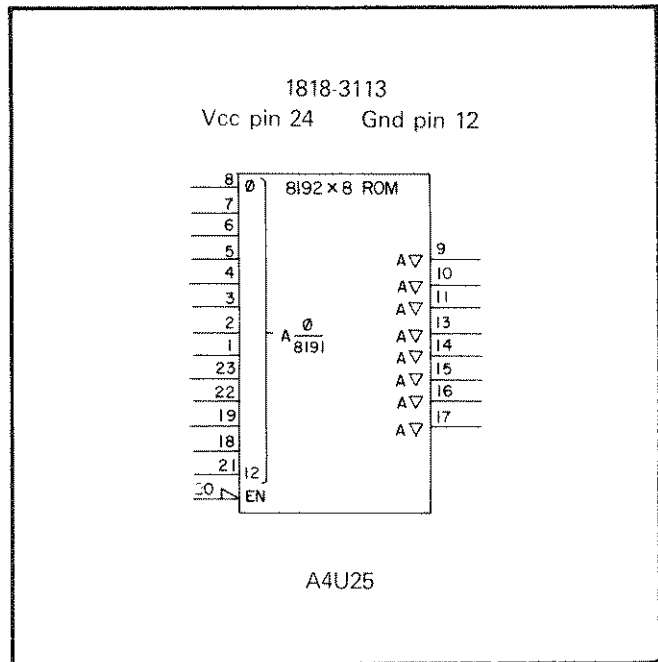

Figure B-29. Read Only Memory (ROM)

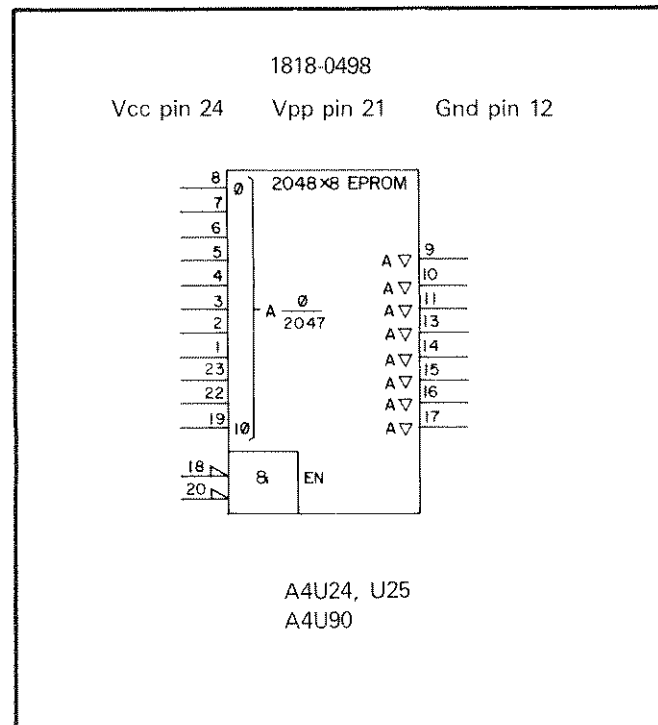

Figure B-30. Erasable Programmable Read Only Memory (EPROM)

**Bus Transceiver.** Figure B-31 shows a bus transceiver that provides bidirectional interfacing between the unit and the HP-IB. The device contains four transceivers; the following describes the section connected between pins 3 and 2.  $\square$  indicates that the bus receivers have bithreshold (Schmitt Trigger) inputs. Enable 3 (active high) and enable 4 (active low) enable either the transmitter output at pin 3 or the receiver output at pin 2. The transmitter output is either three-state active pullup (mode 1) or open collector (mode 2).

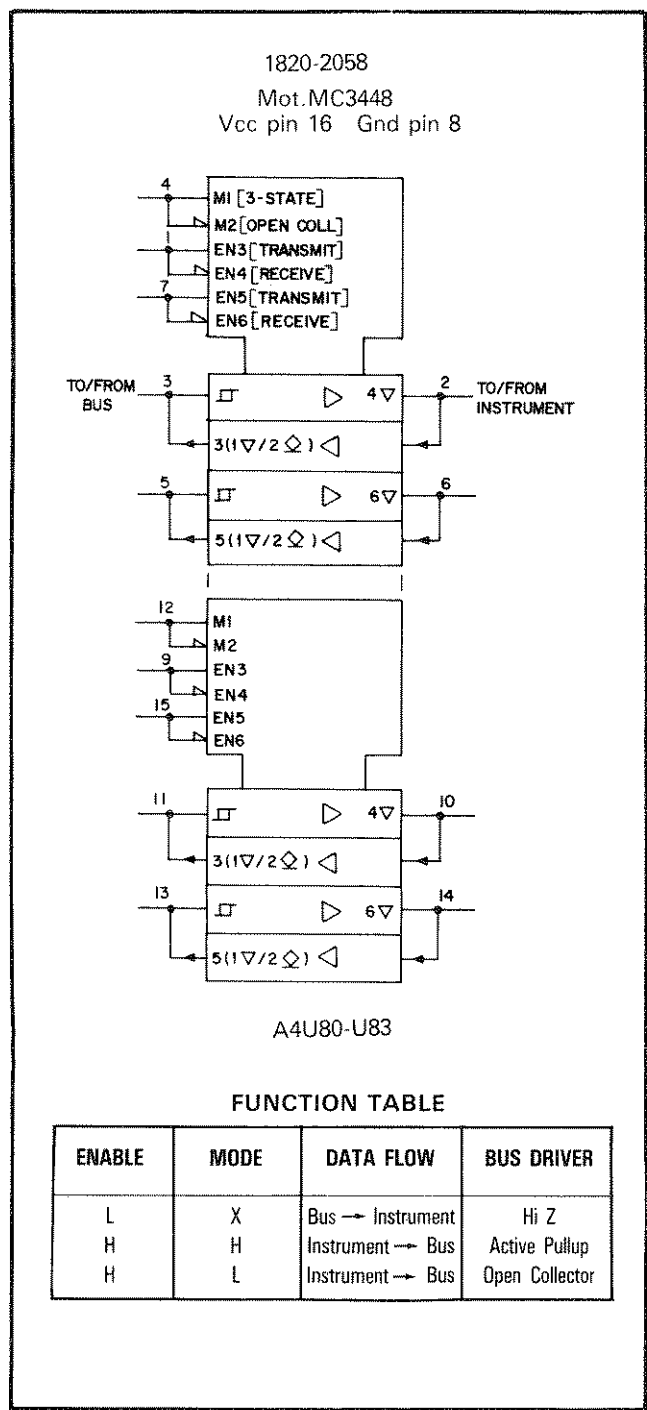

Figure B-31. Bus Transceiver

**Digital-to-Analog Converter (DAC).** The analog output of a digital-to-analog converter is a current that is proportional to the maximum possible current divided by the binary value at the digital input. Figure B-32 shows an eight-bit DAC that also includes an analog multiplier input (range). The 12-bit DAC shown in Figure B-33 includes two feedback resistors provided for use with an external op amp.

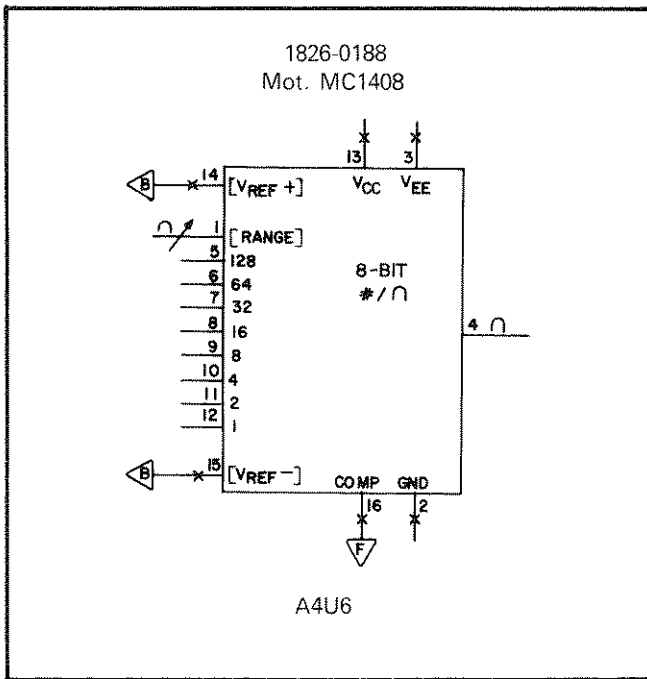

Figure B-32. 8-Bit Digital-to-Analog Converter

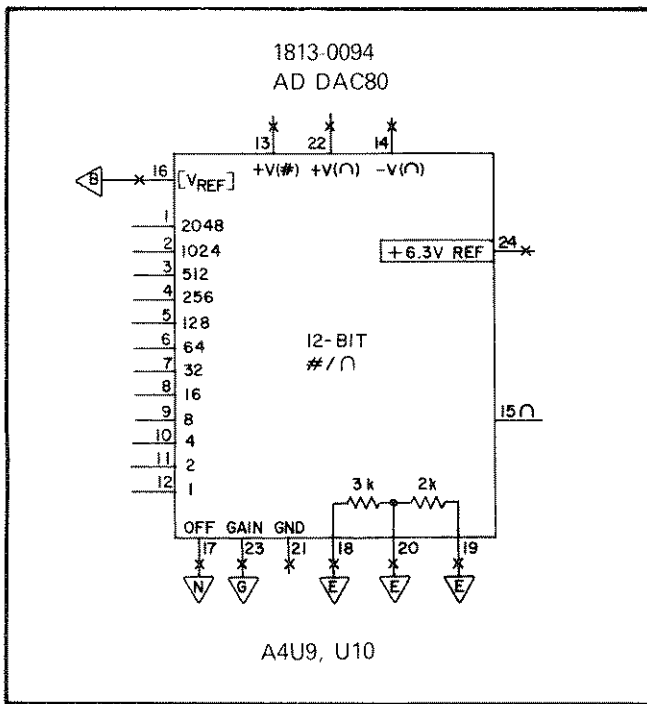

Figure B-33. 12-Bit Digital-to-Analog Converter

## LINEAR DEVICES

**Operational Amplifiers.** The source of gain in an operational amplifier can be characterized as an ideal, differential voltage amplifier having low output impedance, high input impedance, and very high differential gain. The output of an operational amplifier is proportional to the difference in the voltages applied to the two input terminals. In use, the amplifier output drives the input voltage difference close to zero through a feedback path.

When troubleshooting an operational amplifier circuit, measure the voltages at the two inputs; the difference between these voltages should be less than 10 mV. (Note: This troubleshooting procedure will not work for operational amplifiers which are configured as comparators.) A difference voltage much greater than 10 mV indicates trouble in the amplifier or its external circuitry. Usually, this difference will be several volts and one of the inputs will be very close to one of the supply voltages (e.g., +15 V or -15 V).

Next, check the amplifier's output voltage. It will probably also be close to one of the supply voltages (e.g., ground, +15 V, or -15 V). Check to see that the output conforms to the inputs. For example, if the inverting input is more positive than the non-inverting input, the output should be negative; if the non-inverting input is more positive than the inverting input, the output should be positive. If the output conforms to the inputs, check the amplifier's external circuitry. If the amplifier's output does not conform to its inputs, it is probably defective.

Figures B-34, B-35 and B-36 show typical operational amplifier configurations. Figure B-34 shows a non-inverting buffer amplifier with a gain of 1. Figure B-35 is a non-inverting amplifier with gain determined by R1 and R2. Figure B-36 is an inverting amplifier with a gain determined by R1 and R2.

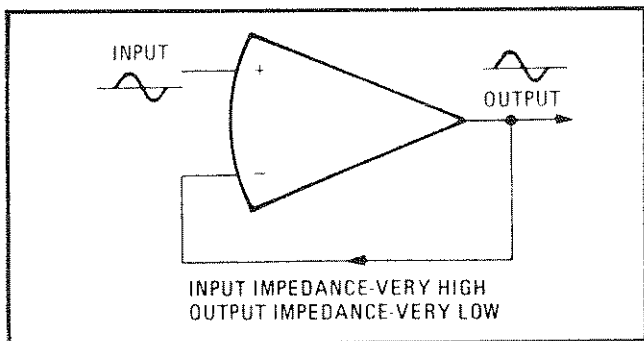

Figure B-34. Non-Inverting Amplifier (Gain = 1)

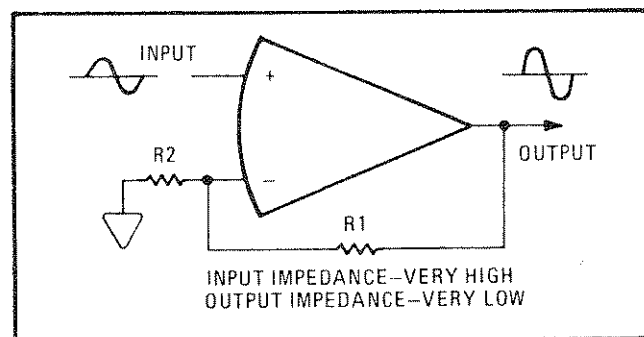

Figure B-35. Non-Inverting Amplifier (Gain =  $1 + R1/R2$ )

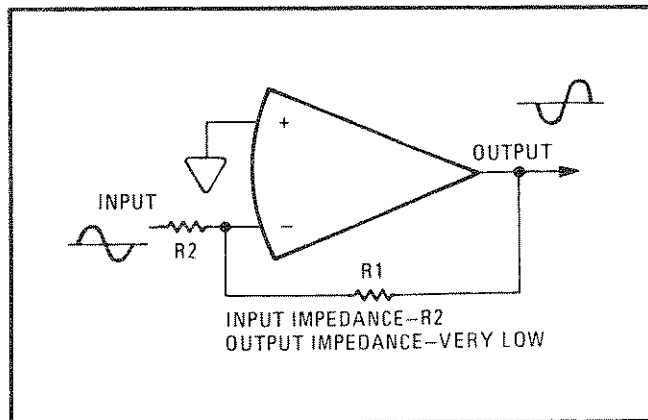

Figure B-36. Inverting Amplifier (Gain =  $-R1/R2$ )

**Comparators.** Comparators are used as level sense amplifiers, switch drivers, pulse height discriminators, and voltage comparators. A voltage reference is connected to one of the amplifier's inputs as shown in Figure B-37 and B-38. When the input signal voltage crosses the reference, the output goes positive; the output remains positive until the signal re-crosses the reference.

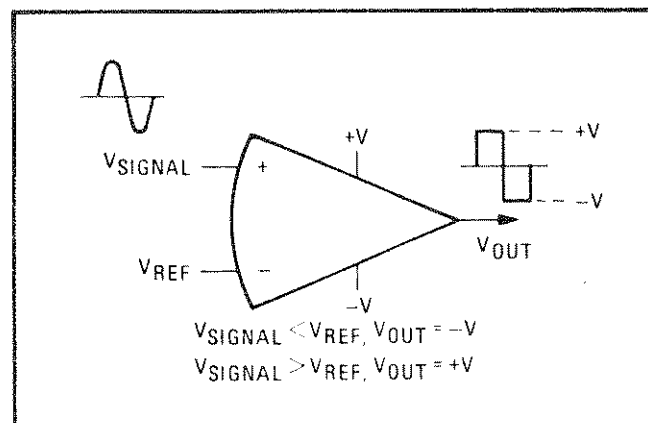

Figure B-37. Non-Inverting Comparator

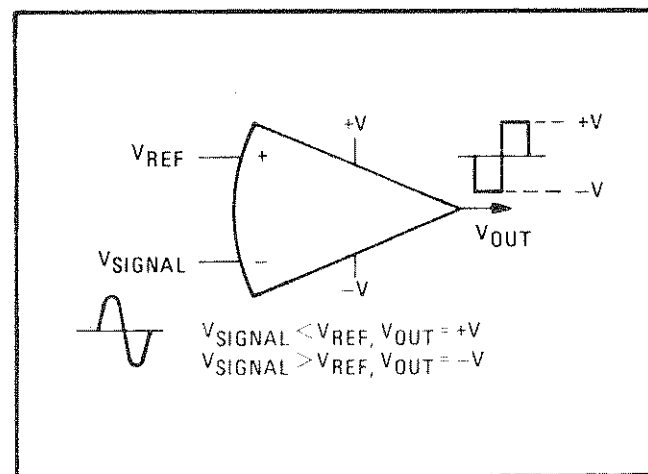

Figure B-38. Inverting Comparator

## Appendix C

# MANUAL BACKDATING CHANGES

This appendix describes changes that must be made to the manual to adapt the manual to instruments with serial numbers lower than 2231A-00831. Look up the serial number for your instrument in the following table, and make only the manual changes listed for your instrument. Note that some changes require modification of the instrument. These changes should be done only if the components listed in the change must be repaired or replaced. HP Service Notes are available from your nearest Hewlett-Packard Service Center.

PREFIX	SERIAL NUMBER	MAKE CHANGES
2222A	00751-00830	1
2222A	00591-00750	1,2
2141A	00271-00590	1-4
2138A	00221-00270	1-5
2134A	00151-00220	1-6
2115A	00101-00150	1-7

### CHANGE 1

On the schematic diagram for Power Mesh/Control Board, replace A1R67 and A1R68 with A1L4 and A1L5, 22 $\mu$ H; change A2R32 and A2R33 to 20 k; and delete A1U12B, A1R163, and A1R262.

If any of the following components must be replaced, the unit should be modified with Service Kit 5080-2021 according to the instructions in HP Service Note 6034A-6: A1CR11, A1CR12, A1L4, A1L5, A1Q1, A1Q2, A1Q3, A1Q4, A1R14, A1R16, A1R21, A1R23, A1T3, A1T4. Make note of the unit's modification so that subsequent repair of A1Q1, A1Q2 and associated components can be done with HP Service Kit 5080-1953.

### CHANGE 2

These units have three 16k EPROMs (A4U25, U90, U24) instead of one 64 k ROM (A4U25). Figure C-1 is a schematic representation of A4U25, U90, and U24. Refer to Figure 7-3 for jumper connections.

Figure C-2 shows signatures for A4U25, U90, U24 in free-run mode, which should be used in place of the A4U25 signatures shown in Figure 5-12. Figure C-3, EPROM Data Test, replaces Figure 5-14, ROM Data Test. Figures C-4 and C-5 show signatures for memory chip select A4U22 in free-run mode and signature analysis mode, and should be used in place of the A4U22 signatures given in Figures 5-12 and 5-15.

If any of the EPROMs have to be replaced, all three EPROMs should be replaced with one ROM according to the instructions in HP Service Note 6034A-6.

### CHANGE 3

These units have the four RPG wires soldered to the A3 Front-Panel Assembly instead of connector J5. When replacing RPG be certain to re-solder wires in correct position. As viewed from front, left-to-right order is: white with red tracer, white with brown and black tracers, white with red and black tracers, black (colors are labeled on front of printed-circuit board). HP Part Number of RPG without connector is 5060-0329.

### CHANGE 4

On some early production units, REGULATION potentiometer A3R78 is connected as shown in Figure C-6. If D/A converter A4U9 has to be replaced, or if A3R78 does not have sufficient adjustment range, the instrument should be modified according to the instructions in HP Service Note 6034A-4.

### CHANGE 5

On these units, A4C55 on the HP-IB/Microcomputer assembly is 0.22 $\mu$ F. If A4C55 has to be replaced, replace with 1 $\mu$ F capacitor as listed in parts list.

### CHANGE 6

If unit occasionally fails turn-on self test, check to see if A4U51 is installed in a socket or is soldered directly to printed-circuit board. If soldered to printed-circuit board, instrument should be modified according to instructions in HP Service Note 6034A-3.

### CHANGE 7

On these units, A3R121 and R145 on the Front-Panel Assembly are 200 $\Omega$ . If either resistor has to be replaced, replace both with 100 $\Omega$  resistors as listed in parts list.

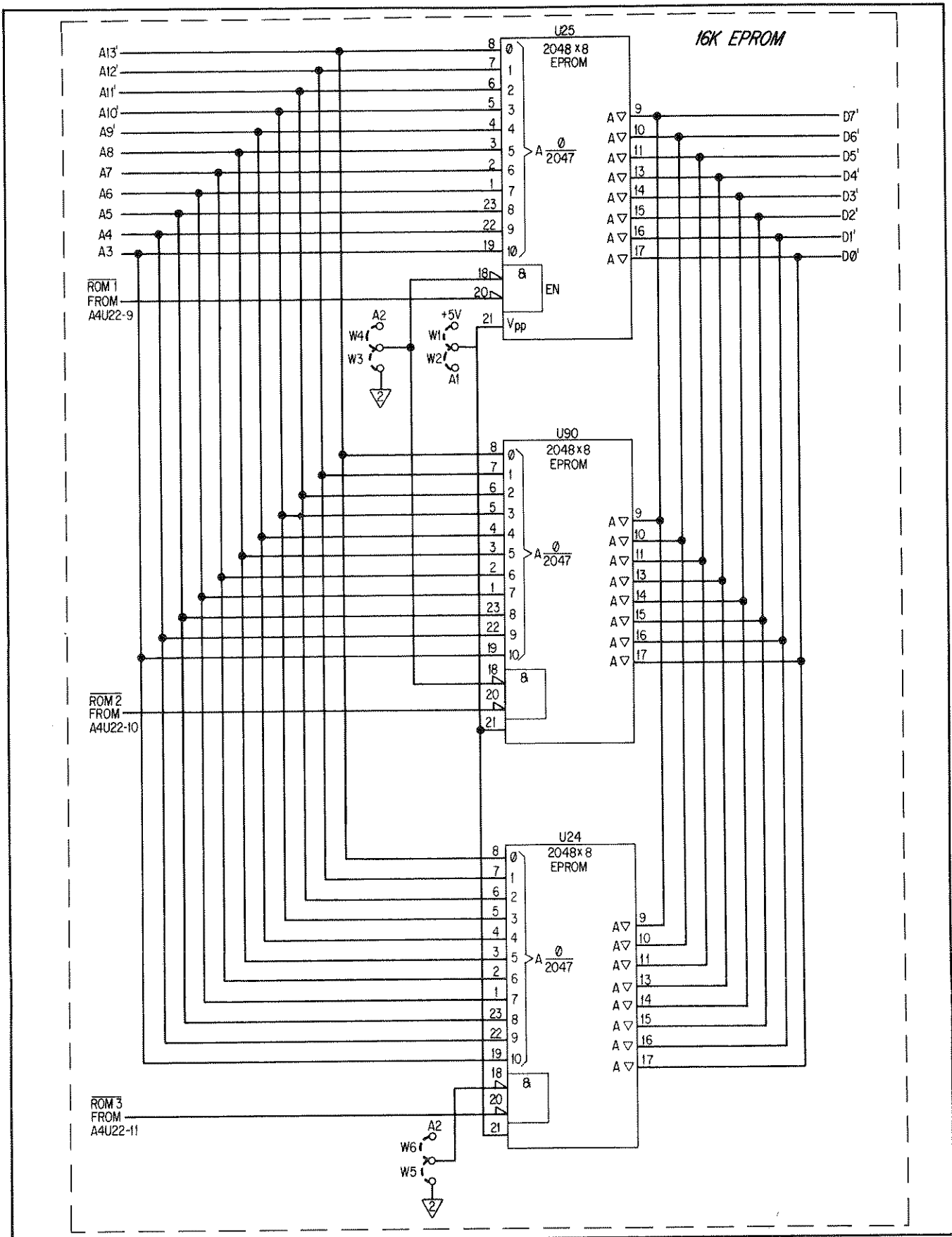

Figure C-1. U25, U90, U24 Schematic



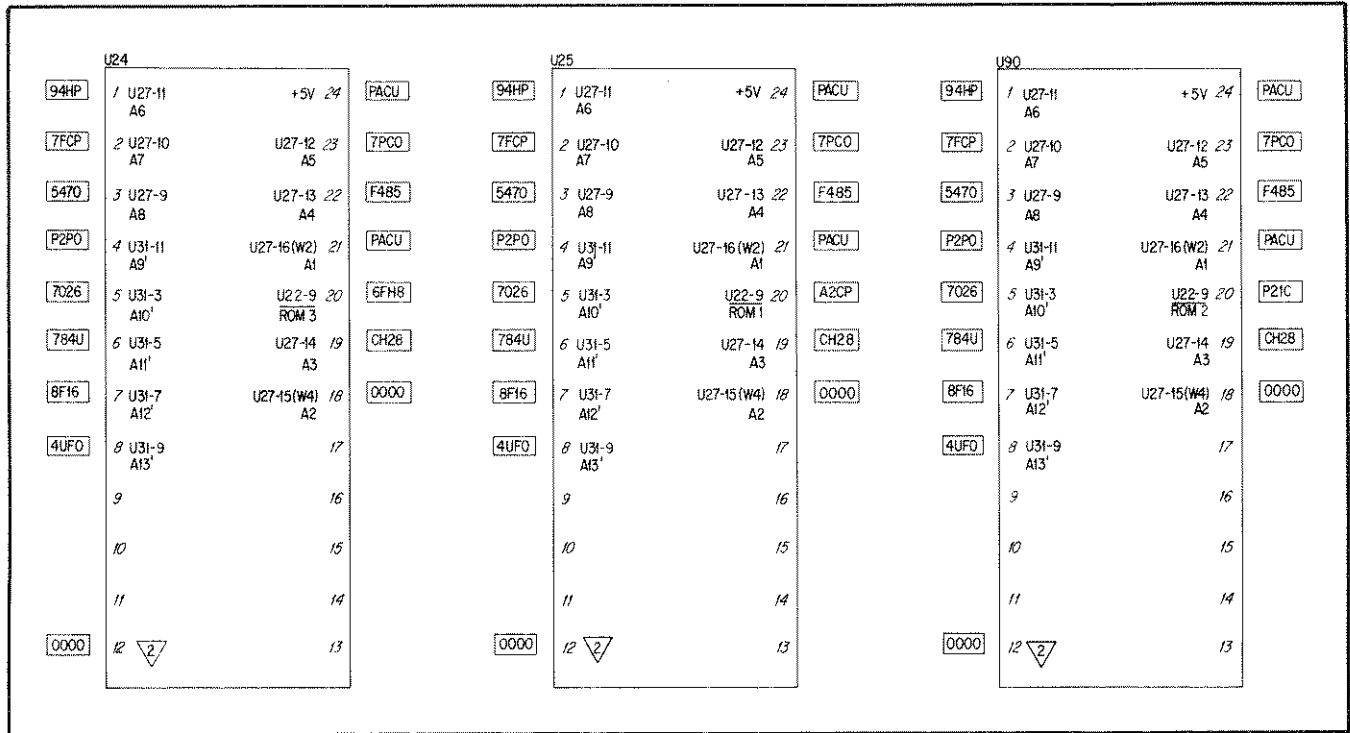

Figure C-2. EPROM Signature Chart, Free-Run Mode

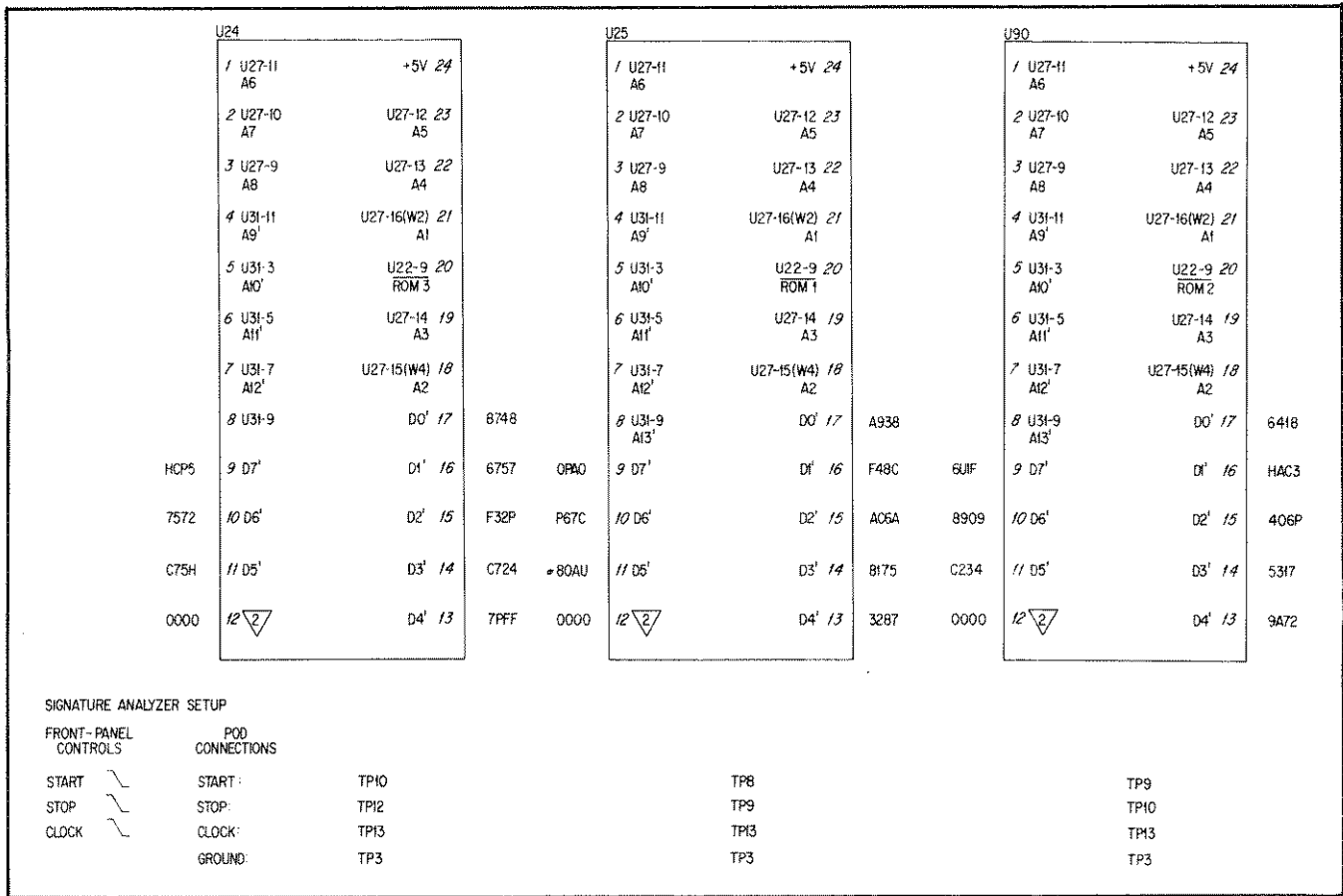

Figure C-3. EPROM Data Test

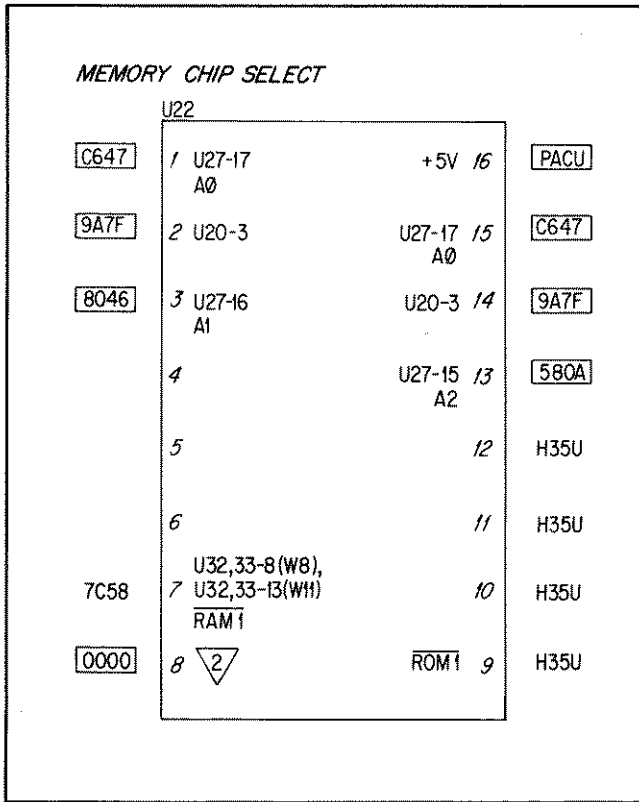

Figure C-4. A4U22 Signatures, Free-Run Mode

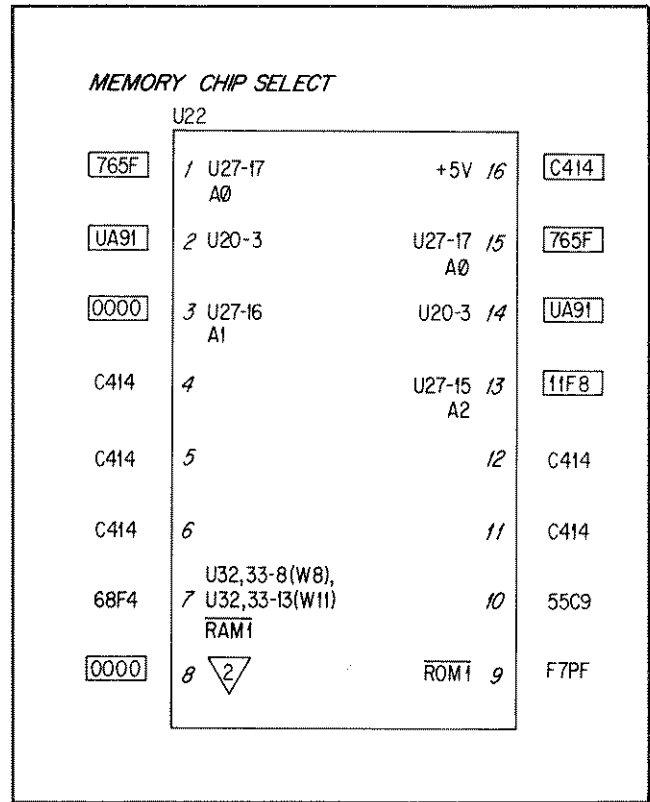

Figure C-5. A4U22 Signatures, Signature Analysis Mode

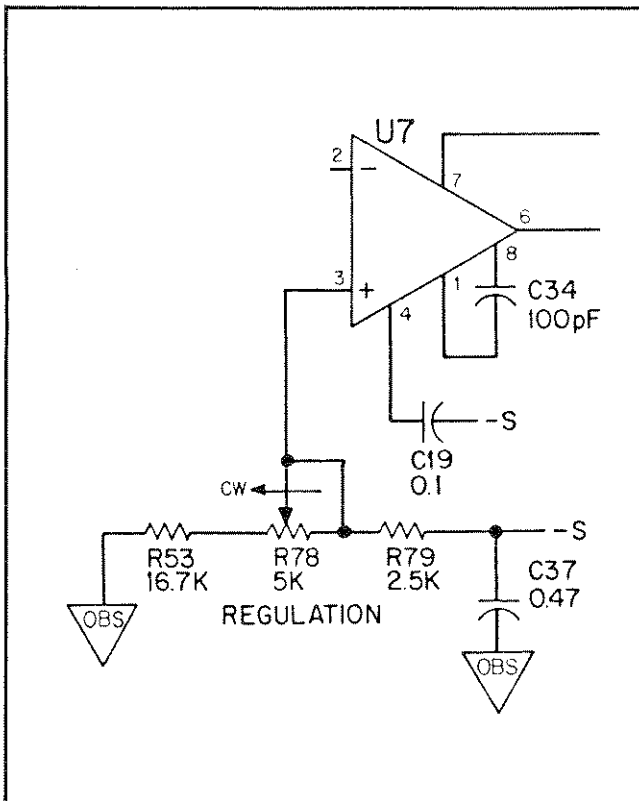

Figure C-6. A3R78/U7 Schematic