



***OPERATING AND
SERVICE MANUAL***

**AUTORANGING
DC POWER SUPPLY
HP MODEL 6024A**

HP Part No. 06024-90001

**OPERATING AND SERVICE MANUAL FOR
SERIALS 1912A-00101 AND ABOVE***

***For Serials above 1912A-00101
a change page may be included.**

Printed: June 1980

CERTIFICATION

Hewlett-Packard Company certifies that this product met its published specifications at time of shipment from the factory. Hewlett-Packard further certifies that its calibration measurements are traceable to the United States National Bureau of Standards, to the extent allowed by the Bureau's calibration facility, and to the calibration facilities of other International Standards Organization members.

WARRANTY

This Hewlett-Packard hardware product is warranted against defects in material and workmanship for a period of one year from date of delivery. HP software and firmware products, which are designated by HP for use with a hardware product and when properly installed on that hardware product, are warranted not to fail to execute their programming instructions due to defects in material and workmanship for a period of 90 days from date of delivery. During the warranty period Hewlett-Packard Company will, at its option, either repair or replace products which prove to be defective. HP does not warrant that the operation for the software firmware, or hardware shall be uninterrupted or error free.

For warranty service, with the exception of warranty options, this product must be returned to a service facility designated by HP. Customer shall prepay shipping charges by (and shall pay all duty and taxes) for products returned to HP for warranty service. Except for products returned to Customer from another country, HP shall pay for return of products to Customer.

Warranty services outside the country of initial purchase are included in HP's product price only if Customer pays HP international prices (defined as destination local currency price, or U.S. or Geneva Export price).

If HP is unable, within a reasonable time, to repair or replace any product to a condition as warranted, the Customer shall be entitled to a refund of the purchase price upon return of the product to HP.

LIMITATION OF WARRANTY

The foregoing warranty shall not apply to defects resulting from improper or inadequate maintenance by the Customer, Customer-supplied software or interfacing, unauthorized modification or misuse, operation outside of the environmental specifications for the product, or improper site preparation and maintenance. NO OTHER WARRANTY IS EXPRESSED OR IMPLIED. HP SPECIFICALLY DISCLAIMS THE IMPLIED WARRANTIES OF MERCHANTABILITY AND FITNESS FOR A PARTICULAR PURPOSE.

EXCLUSIVE REMEDIES

THE REMEDIES PROVIDED HEREIN ARE THE CUSTOMER'S SOLE AND EXCLUSIVE REMEDIES. HP SHALL NOT BE LIABLE FOR ANY DIRECT, INDIRECT, SPECIAL, INCIDENTAL, OR CONSEQUENTIAL DAMAGES, WHETHER BASED ON CONTRACT, TORT, OR ANY OTHER LEGAL THEORY.

ASSISTANCE

The above statements apply only to the standard product warranty. Warranty options, extended support contracts, product maintenance agreements and customer assistance agreements are also available. Contact your nearest Hewlett-Packard Sales and Service office for further information on HP's full line of Support Programs.

MANUAL CHANGES
 Model 6024A DC Power Supply
 Manual HP P/N 06024-90001
 8/29/90

Make all corrections in the manual according to errata below, then check the following table for your power supply serial number and enter any listed changes(s) in the manual.

SERIAL		MAKE CHANGES
Prefix	Number	
All	---	Errata
2126A	00611-00660	1
2129A	00661-01390	1,2
2229A	01391-02290	1,2,3
2332A	02291-02990	1,2,3,4
2430A	02991-03865	1-5
2526A	03866-05035	1-6
2701A	05036-06315	1-7
2905A	06316-06475	1-8
2918A	06476-06495	1-9
2918A	06496-06515	1-8
2918A	06516-06635	1-9
2926A	06636-07175	1-10
3031A	07176-up	1-11

In Table A-1, under REMOTE PROGRAMMING, Accuracy specifications should be: CV; 0.8% + 30mV CC; 2.5% + 10mA.

In the replaceable parts list for A2 Control Board Assembly, add: C22, HP P/N 0140-0203, 30pF 5% 500 V MICA; R63, HP P/N 0683-1065, 10 M 5% .25 W F; R64, HP P/N 0698-5094, 5.1 M 5% .25 W F.

CHANGE 1:

In the replaceable parts list, page 6-8 Delete Support Spacers HP P/N 1390-0481 and Add NUT EXPANSION HP P/N 0590-1422.

CHANGE 2:

In the replaceable parts list, page 6-5 change C23 to 2.2 uF Polyester, HP P/N 0160-5377 and C28 to Fixed electrolytic 390 uF, 20 Vdc HP P/N 0180-3056.

CHANGE 3

On page 6-3 change Q1,2 to HP P/N 5080-2017.

Delete inductors L4,5 HP P/N 9140-0179 from the replaceable parts list and the schematic diagram. Replace L4,5 with R67, R68, 62 ohm, 1/8 W, HP P/N 0698-4132. R67,68 should have asterisks marked next to them when added to the parts list.

On page 6-4 change T3,4 to HP P/N 5080-2018. Also, T3, 4 should have asterisks marked next to them.

On page 6-4 add U12, IC. driver, HP P/N 1820-1050, qty 1. and also add R163, 263 Fixed comp., 2.7 ohm +/-5%, 1/4 W, HP P/N 0683-0275, qty 2. When adding these components to the parts list, mark an asterisk next to them.

In Table 1-1, under REMOTE PROGRAMMING, Accuracy specifications should be:

Resistance Programming

CV; 0.8% + 12 mV CC; 2.5% + 2mA

Voltage Programming

CV; 0.2% +2 mV CC; 1.0% +2mA

Current Programming

CV; 0.2% +0.36 V + accuracy of resistor CC; 1.0% + 0.15 A + accuracy of resistor

On Figure 5-3 and 5-4, the power supply - and -S terminals should be connected to the power supply frame ground terminal.

Paragraph 5-44 step (a.) should be: Connect test setup shown in Figure 5-7. Set RL to minimum resistance initially. Paragraph 5-44 step (f.) should begin: Increase resistance of RL until DVM reads exactly 20 V (maximum rated power output Ensure that power supply remains in constant-current mode.

Paragraph 5-81 step (c.) should be: Adjust A2R65 less than +/-2mV on DVM. Paragraph 5-87 step (d.) should be: Adjust A2R91 for less than +/-0.2 mV on DVM (less than 2 mA through shunt). Paragraph 5-89 step e should be: Adjust A2R92 for 0.1 V +/-0.2 mV on DVM (10 A +/-20 mA output).



U12A and U12B, R163, R263 should be added to schematic 7-6 in parallel with U2A as shown below:

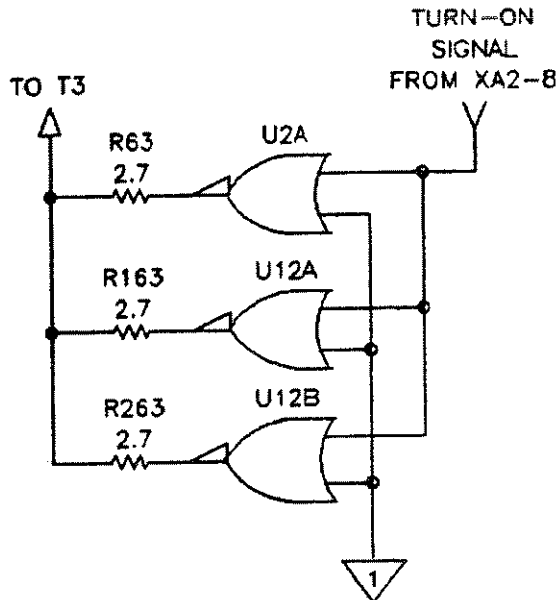

On page 6-5 in the replaceable parts list change R32,33 to 24.3 k ohm +/-1%, 1/8 W HP P/N 0757-0451, qty 2.

ERRATA:

For units with serial numbers up to 2129A-1390, if any parts in service kit have to be replaced, unit must be modified with Service Kit 5080-2021 according to instructions in HP Service Note 6024-1. Make note of units modification so that subsequent repair of A1Q1, A1Q2 and associated components can be done with HP Service Kit 5080-1953.

CHANGE 4:

In the replaceable parts list page 6-6 and on the schematic figure 7-6 change R63 to 5.1M ohms, .25W, qty.1., HP P/N 0698-5094 and R64 to 2.7M ohms, .25W, qty.1., HP P/N 0683-2755.

ERRATA

On page 1-2, under ACCESSORIES delete Support shelf HP P/N 5061-0097 and Slide kit HP P/N 1494-0015. Add to the Options list on page 1-2 option #907, Front Handle Kit 5061-0089, and option #908, Rack Mtg. Flange Kit HP P/N 5061-0057.

ERRATA:

On page 1-2 change Accessory HP P/N 5061-0071 to HP P/N 5061-0058. On the same page, in the Description for Accessory HP P/N 5061-2025, delete the last part of the sentence, "extender card for servicing control board". On page 2-2, paragraph 2-21, the first sentence should read; "To protect operating personnel, the National Electrical Manufacturers Association (NEMA) recommends..."

On page 5-15, figure 5-14, change the decision box reading: "Voltage Across A1C35 approx. 6.5V ?" to "Voltage Across A1C32 approx. 6.5V ?". On page 3-1, paragraph 3-4, step d., change the last word of the sentence to "Voltmeter".

On page 3-11, paragraph 3-75, add before the first sentence, the following paragraph title; "Auto Series with Remote Programming" On page 6-8, under Chassis Mechanical, change Jumper, Terminal Block (TB1) to HP P/N 0360-1935, qty. 6. On page 1-1, under OPTIONS add option 800, Dual Rack Mount Kit. This option provides hardware to rack mount the supply.

CHANGE 5

In the replaceable parts list, page 6-7, change CHASSIS MECHANICAL, change CHASSIS ASSY, FRONT to 06024-60027. Under METER BOARD ASSEMBLY, change VOLTMETER to HP P/N 1120-1904 and AMMETER to HP P/N 1120-1903. On page 6-7, under Chassis-Mech., change Chassis Assy, Front to HP P/N 06024-00016.

In Appendix B Option 100, page B-4, change in paragraph B-50 Voltmeter to HP P/N 1120-1906 and Ammeter to HP P/N 1120-1905.

CHANGE 6:

In the replaceable parts list, page 6-7 and 6-8, under CHASSIS MECHANICAL, change Chassis Assy, Rear Panel to HP P/N 06024-00017, Chassis Assy, Left Side to HP P/N 06024-00018 and Chassis Assy, Right Side to HP P/N 06024-00019.

On page 1-2 under paragraph 1-16 Accessories change Rack Mounting Adapter for 5 1/4 inch high cabinets to HP P/N 5061-9657, Front Handle Kit to HP P/N 5061-9689, Bail Handle Kit to HP P/N 5061-9702, Rack Flange Kit to HP P/N 5061-9677, Rack Flange and Front Handle to HP P/N 5061-9683, Lock-together kit, to HP P/N 5061-9694, Rack Mounting Adapter Kit for Center Mounting to HP P/N 5061-9671, Support Shelf to HP P/N 5061-9697 and Slide Kit to HP P/N 1494-0065.

In Section V under paragraph 5-64 Repair and Replacement add the following CAUTION; Most of the attaching hardware in this unit is English (inch). The only metric fittings are listed below. Be careful when both types of screws are removed not to get them mixed up.

- a.) side chassis, rack mounting threaded inserts (3 per side).
- b.) rear panel, lock link threaded inserts (4 per panel).

CHANGE 7:

In the replaceable parts list, page 6-7 and 6-8, under CHASSIS MECHANICAL, change Chassis Assy, Rear Panel to HP 06024-00003, Chassis Assy, Left Side to HP P/N 06024-00004 and Chassis Assy, Right Side to HP P/NO 06024-00005. Delete the CAUTION that was added in Change 6 from the manual.

CHANGE 8:

In the replaceable parts list, change the part number for L10 from HP P/N9170-1134 (qty 1) to HP P/N9170-1466 (qty 2).

CHANGE 9:

In the replaceable parts list and on the schematic, change R28 and R29 from 0.4 ohms, 5%, 20W, Center Tapped HP P/N 0811-1817 to 0.1 ohm, 5%, 20W, HP P/N 0811-3823 (qty 2)

CHANGE 10:

In the replaceable parts list, change the part number for the following parts:

Description	From	To	Qty
Front Panel	06024-00001	06024-00024	1
Cover Top	06024-00008	06024-00020	1
Chassis Right	06024-00005	06024-00021	1
Chassis Left	06024-00004	06024-00022	1
Feet	5040-7201	5041-8801	4
Trim Sides	5001-0439	5001-0539	2
Front Bezel	06024-00002	06024-00023	1
Front Pan. Let.	06024-00015	06024-00025	1

Also change the rack kit part numbers from HP P/N 5061-9677 to HP P/N 5062-3977 (qty 1).

Also change the rack kit part number for Option 908 from HP P/N 5061-9657 to HP P/N 5062-3957 (qty 1).

CHANGE 11:

In the parts list on page 6-7, make the following changes under Chassis-Electrical: Change FL1 from HP P/N 9135-0124 to HP P/N 9135-0425. Also add: Cable Assembly, 2-wire (fan) HP P/N 8120-3468 (qty 1). On page 6-8, change the rear panel assembly from HP P/N 06024-00003 to HP P/N 06024-00026.



SAFETY SUMMARY

The following general safety precautions must be observed during all phases of operation, service, and repair of this instrument. Failure to comply with these precautions or with specific warnings elsewhere in this manual violates safety standards of design, manufacture, and intended use of the instrument. Hewlett-Packard Company assumes no liability for the customer's failure to comply with these requirements.

BEFORE APPLYING POWER

Verify that the product is set to match the available line voltage.

GROUND THE INSTRUMENT

This product is a Safety Class 1 instrument (provided with a protective earth terminal). To minimize shock hazard, the instrument chassis and cabinet must be connected to an electrical ground. The instrument must be connected to the ac power supply mains through a three-conductor power cable, with the third wire firmly connected to an electrical ground (safety ground) at the power outlet. Any interruption of the protective (grounding) conductor or disconnection of the protective earth terminal will cause a potential shock hazard that could result in personal injury. If the instrument is to be energized via an external autotransformer for voltage reduction, be certain that the autotransformer common terminal is connected to the neutral (earthed pole) of the ac power lines (supply mains). This instrument is equipped with a line filter to reduce electromagnetic interference (EMI), and must be connected to a properly grounded receptacle to minimize EMI.

FUSES

Fuses are contained inside the unit, and are not user-replaceable. Only trained service personnel should replace blown fuses, and only after identifying and correcting the problem which caused the fuse(s) to blow.

DO NOT OPERATE IN AN EXPLOSIVE ATMOSPHERE

Do not operate the instrument in the presence of flammable gases or fumes.

KEEP AWAY FROM LIVE CIRCUITS

Operating personnel must not remove instrument covers. Component replacement and internal adjustments must be made by qualified service personnel. Do not replace components with the power cable connected. Under certain conditions, dangerous voltages may exist even with the power cable removed. To avoid injuries, always disconnect power, discharge circuits and remove external voltage sources before touching components.

DO NOT SERVICE OR ADJUST ALONE

Do not attempt internal service or adjustment unless another person, capable of rendering first aid and resuscitation, is present.

DO NOT EXCEED INPUT RATINGS

Operation at line voltages or frequencies in excess of those stated on the data plate may cause leakage currents in excess of 3.5 mA peak.

SAFETY SYMBOLS



Instruction manual symbol: the product will be marked with this symbol when it is necessary for the user to refer to the instruction manual (refer to Table of Contents).



Indicates hazardous voltages.



or



Indicate earth (ground) terminal.



or

Warning



The WARNING sign denotes a hazard. It calls attention to a procedure, practice, or the like, which, if not correctly performed or adhered to, could result in personal injury. Do not proceed beyond a WARNING sign until the indicated conditions are fully understood and met.



or

Caution



The CAUTION sign denotes a hazard. It calls attention to an operating procedure, or the like, which, if not correctly performed or adhered to, could result in damage to or destruction of part or all of the product. Do not proceed beyond a CAUTION sign until the indicated conditions are fully understood and met.

DO NOT CIRCUMVENT SAFETY DEVICES

AC mains power exists on exposed terminals in various locations in the mainframe and on the load modules. To protect the user against the danger of electric shock, the unit is equipped with a safety interlock that removes ac mains power when the top cover is removed. Do not attempt to defeat the function of the safety interlock.

DO NOT SUBSTITUTE PARTS OR MODIFY INSTRUMENT

Because of the danger of introducing additional hazards, do not install substitute parts or perform any unauthorized modification to the instrument. Return the instrument to a Hewlett-Packard Sales and Service Office for service and repair to ensure that safety features are maintained.

Instruments which appear damaged or defective should be made inoperative and secured against unintended operation until they can be repaired by qualified service personnel.

ACOUSTIC NOISE INFORMATION

HP Model 6024A has been tested in accordance with German acoustic noise specification 3.GSGV. The results of these tests are listed below.

ACOUSTIC NOISE EMISSION

LpA < 70 dB
operator position
normal operation
per ISO 7779

GERAeUSCHEMISSION

LpA < 70 dB
am Arbeitsplatz
normaler Betrieb
nach DIN 45635 T. 19

SECTION I GENERAL INFORMATION

1-1 DESCRIPTION

1-2 The Model 6024A is an autoranging 200-watt power supply providing laboratory-grade performance with the high efficiency of switching regulation techniques. Autoranging allows the supply to furnish 20 watts output power over a wide range of output voltage and current combinations without the user having to select the proper output range. The output is adjustable through the entire operating range of 0 to 60 volts and 0 to 10 amperes by 10-turn front-panel controls.

1-3 The supply is of the Constant Voltage/Constant Current (CV/CC) type with front-panel LEDs to indicate whether the unit is operating in CV or CC mode. Output voltage and current are continuously indicated on individual front-panel meters. A red LED indicates an overvoltage condition. The overvoltage protection (OVP) circuit protects the user's load by quickly and automatically interrupting energy transfer if a preset trip voltage is exceeded. A screwdriver control on the front panel sets the overvoltage trip point between 2V and 64V.

1-4 Connections to the output are made either to front-panel binding posts or rear-panel screw-on terminals. Either the positive or negative output terminal may be grounded, or the output may be floated at up to 240 volts DC from ground.

1-5 Remote programming, remote sensing, and several methods of operating multiple supply combinations are possible by making connections to rear-panel terminals. These capabilities are more fully described in Section III.

1-6 The unit is fan cooled and is packaged in an Hewlett-Packard System II-compatible modular enclosure, which is sturdy, attractive, and provides easy access for servicing.

1-7 SAFETY CONSIDERATIONS

1-8 This product is a Safety Class I instrument (provided with a protective earth terminal). The instrument and this manual should be reviewed for safety markings and instructions before operation.

1-9 SPECIFICATIONS

1-10 Detailed specifications for the power supply are given in Table 1-1.

1-11 INSTRUMENT AND MANUAL IDENTIFICATION

1-12 Hewlett-Packard power supplies are identified by a two-part serial number. The first part is the serial number prefix, a number-letter combination that denotes the date of a significant design change and the country of manufacture. The first two digits of the prefix indicate the year (19 = 1979, 20 = 1980, etc), the second two digits indicate the week, and the letter "A" designates the USA as the country of manufacture. The second part of the serial number is a different sequential number assigned to each power supply, starting with 00101.

1-13 If the serial number on your instrument does not agree with those on the title page of this manual, a yellow Manual Changes sheet supplied with the manual defines the difference between your instrument and the instrument described by this manual.

1-14 OPTIONS

1-15 Options are standard factory modifications that are requested by the customer. The following options are available with this instrument. Option 002 is described in Appendix A.

OPTION NO.

DESCRIPTION

002

Systems Option: allows the supply to operate automatically in system applications. Provides resistance, voltage, and current programming of voltage and current; six isolated status lines; three isolated control lines; +5V and $\pm 15V$ bias voltages. This option is mounted on a single additional printed-circuit board, which includes a rear-panel connector.

OPTION NO.	DESCRIPTION
220	Input Power: 191 to 233Vac, 48 to 63 Hz, single phase.
240	Input Power: 208 to 250Vac, 48 to 63 Hz, single phase.
910	One additional operating and service manual shipped with the power supply.

1-16 ACCESSORIES

1-17 The System II cabinet accessories listed below may be ordered with the power supply or separately from your local Hewlett-Packard Sales and Service office (see list of addresses at the rear of this manual).

<u>HP Part No.</u>	<u>Description</u>
5061-0089	Front handle kit for 5-1/4 inch high cabinets.
5061-2002	Bail handle kit for 5-1/4 inch high, half-module width cabinets.
1460-1345	Tilt stand snaps into standard foot supplied with unit, must be used in pairs.
5061-0077	Rack flange kit for 5-1/4 inch high cabinets (must be used with another half-module width instrument of same depth and with lock-together kit #5061-0094).
5061-0083	Rack flange and front handle combination kit for 5-1/4 inch high cabinets (must be used with another half-module width instrument of same depth and with lock-together kit #5061-0094).

<u>HP Part No.</u>	<u>Description</u>
5061-0094	Lock-together kit for cabinets of equal depth, enough links for three side-by-side joints (over-under connections are not possible).

5061-0057	Rack mounting adapter kit for 5-1/4 inch high cabinets, includes one rack flange and one half-module width extension adapter.
5061-0071	Rack mounting adapter kit for center mounting one 5-1/4 inch high cabinet, includes one rack flange and one quarter-module width extension adapter; two kits required.
5061-0097	Support shelf for mounting 5-1/4 inch high cabinets of different depths.
1494-0015	Slide kit for support shelf.
5061-2025	Front filler panel; 5-1/4 inch high, half-module width extender card for servicing control board.
5080-1953	FET Service Kit; includes components that should be replaced when FETs are replaced.
06024-60024	Control Board Extender.
1251-6016	Control Board Test Connector.

1-18 ORDERING ADDITIONAL MANUALS

1-19 One manual is shipped with each power supply. Additional manuals may be purchased directly from your local Hewlett-Packard Sales office. Specify the model number, instrument serial number prefix, and the manual part number provided on the title page. (When ordered at the same time as the power supply, additional manuals may be purchased by adding Option 910 to the order and specifying the number of additional manuals desired.)

Table 1-1. Specifications, Model 6024A

All performance specifications are at rear terminals with a resistive load.

INPUT POWER:

Two internal switches and one internal jumper permit operation from 120, 220, or 240Vac (-13%, +6%); 48-63Hz; 320W maximum. Maximum input current is 5.3A rms for 120Vac, 2.9A rms for 220Vac, and 2.7A rms for 240Vac. A three-wire detachable line cord is supplied.

INPUT PROTECTION:

The ac input is protected by a rear-panel mounted fuse; 6A for 120Vac, 4A for 220Vac and 240Vac.

PEAK INRUSH CURRENT:

(typical values)

- @25°C ambient, 25A
30 seconds after turn-off, 30A
- @55°C ambient, 50A
30 seconds after turn-off, 60A

DC OUTPUT:

Adjustable from 0 to 60V and 0 to 10A. Maximum output power is 200W at extremes of voltage and current, increases to approximately 230W at mid-range. (This power is available at load with up to 0.5V drop in each load lead.) See graph:

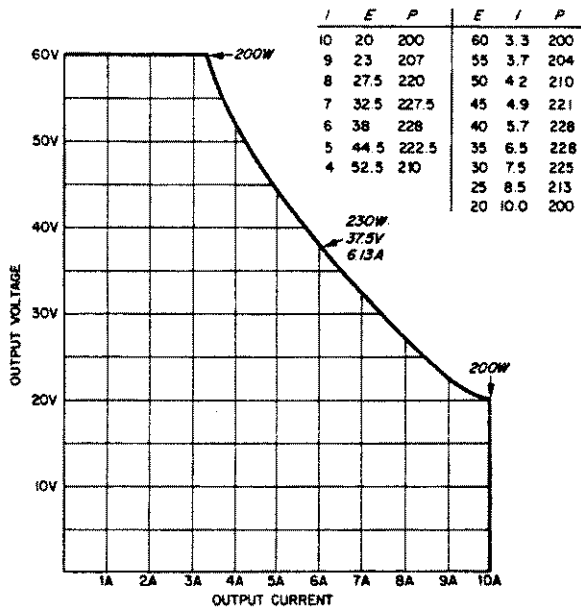

LOAD EFFECT (LOAD REGULATION):

Constant Voltage - Less than 0.01% of output voltage plus 3mV for a load change equal to the maximum available current rating of the supply at the set voltage.

Constant Current - Less than 0.01% of output current plus 3mA for a load change equal to the maximum available voltage rating of the supply at the set current.

SOURCE EFFECT (LINE REGULATION):

Constant Voltage - Less than 0.01% of output voltage plus 2mV for any line voltage change within rating.

Constant Current - Less than 0.01% of output current plus 2mA for any line voltage change within rating.

PARD (Ripple and Noise), 20Hz to 20MHz:

Constant Voltage - Less than 3mV rms and 30mV p-p.

Constant Current - Less than 5mA rms.

TEMPERATURE COEFFICIENT:

Constant Voltage - Less than 0.01% plus 1mV change in output per degree Celsius change in ambient after 30-minute warmup.

Constant Current - Less than 0.03% plus 1mA change in output per degree Celsius change in ambient after 30-minute warmup.

DRIFT (Stability):

(Change in output over an 8-hour interval under constant line, load, and ambient temperature after 30-minute warmup).

Constant Voltage - Less than 0.03% of output plus 3mV.

Constant Current - Less than 0.03% of output plus 3mA.

LOAD TRANSIENT RECOVERY TIME:

Less than 1ms is required for output voltage recovery (in constant voltage operation) to within 75mV of the nominal output following a change in output current from 90% to 100% or 100% to 90% of maximum current rating.

RESOLUTION:

(Minimum output voltage or current change that can be obtained using the 10-turn front-panel controls)

Constant Voltage - 20mV

Constant Current - 5mA

Table 1-1. Specifications, Model 6024A (continued)

OUTPUT IMPEDANCE (Typical):

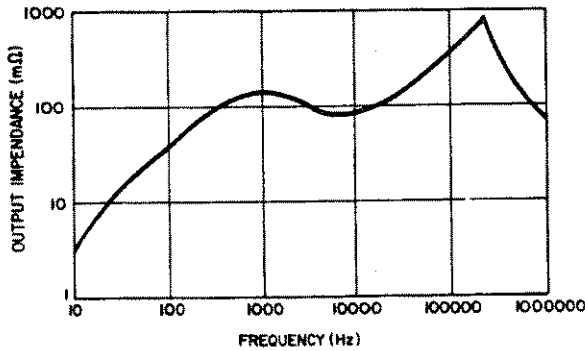

DC OUTPUT ISOLATION:

Either output terminal may be floated up to $\pm 240V_{dc}$ (including output voltage) from earth ground.

OVERVOLTAGE PROTECTION:

Trip voltage adjustable from 2V to 64V. Minimum setting above output voltage to avoid false tripping is 1.5V.

REVERSE VOLTAGE PROTECTION:

(Maximum permissible reverse current caused by reverse voltage impressed across output terminals) 10A continuous.

REMOTE SENSING:

Maintains nominal voltage at load by correcting for load-lead voltage drop of up to 0.5V per lead.

REMOTE PROGRAMMING:

Resistance Programming - 0 to 2.5K provides zero to maximum rated voltage or current output.

Accuracy: CV; 0.8% + 2mV CC; 2.5% + 1mA

Voltage Programming - 0 to 5V provides zero to maximum rated voltage or current output.

Accuracy: CV; 0.2% + 2mV CC; 1.0% + 2mA

Current Programming - 2mA to 0mA current sink provides zero to maximum rated voltage or current output (with user-provided 2.5k resistor).

Accuracy: CV; 0.2% + 0.36V + accuracy of resistor
CC; 1.0% + 0.15A + accuracy of resistor

PROGRAMMING RESPONSE TIME:

Maximum time for output voltage to change from 0V to 60V or 60V to 2V and settle within 60mV band (0.1% of maximum rated output).

Up: Full Load (18 Ω)	200mS
No Load	200mS
Down: Full Load (18 Ω)	300mS
No Load	600mS

Typical response time, for excursions other than full-scale

Down: On graph, read difference in time between initial output voltage and final output voltage; add settling time

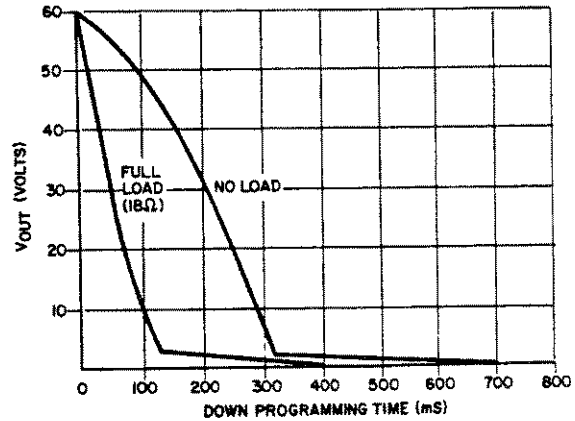

Plus 125ms if final voltage $\geq 2V$
or 500ms if final voltage $< 2V$ to settle within 60mV band (0.1% of maximum rated output)

Up: On graph, read time for change in output voltage

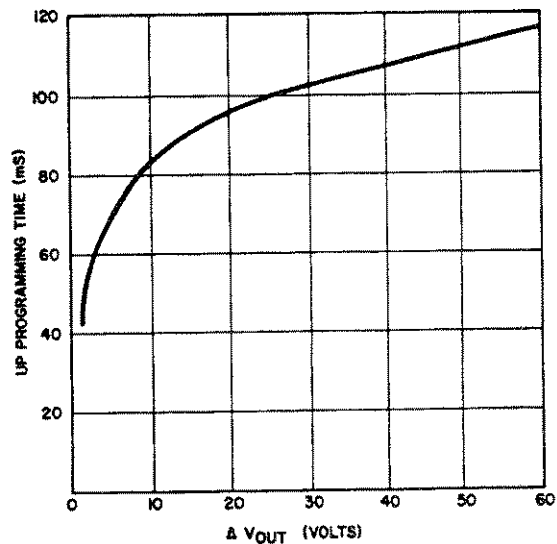

CURRENT MONITORING OUTPUT:

0 to 5V output from rear-panel terminal indicates zero to maximum rated current output; accuracy, 0.9% + 7mV output impedance, 10k.

Table 1-1. Specifications, Model 6024A (continued)

METERS AND INDICATORS:

Voltmeter - Continuously reading 70V scale with secondary scale indicating amperes available; accuracy, $\pm 3\%$ of full scale.

Ammeter - Continuously reading 12A scale with secondary scale indicating volts available; accuracy, $\pm 3\%$ of full scale

VOLTAGE Indicator - Green LED indicates Constant Voltage operation.

CURRENT Indicator - Green LED indicates Constant Current operation.

OUTPUT UNREGULATED Indicator - Red LED indicates that output is unregulated because of any of the following conditions: overrange operation, overvoltage, over temperature, or low-input-power shutdown.

OVP Indicator - Red LED indicates shutdown caused by voltage at output terminals exceeding preset limit.

MULTIPLE UNIT OPERATION:

Auto-Parallel - Up to eight units may be connected in parallel to increase total output current capability while maintaining control from a single unit.

Auto-Series - Up to four units (eight if center-tapped to ground) may be connected in series to increase total output voltage to 240Vdc (480Vdc if center-tapped to ground) while maintaining control from a single unit.

Auto-Tracking - Any number of units may have either one of their output terminals connected to a common bus so that all outputs track, at some fraction, the output of a single, controlled, unit.

TEMPERATURE RATINGS:

Operating: 0 to $+55^{\circ}\text{C}$ Storage: -40 to $+75^{\circ}\text{C}$
Unit is fan cooled. A thermostat turns off unit if temperature rises above a critical level; resets automatically.

OPTIONS:

Option 002 (System Interface) specifications are listed in Appendix A.

CERTIFICATION:

Unit complies with these requirements:
IEC 348 - Safety Requirements for Electronic Measuring Apparatus.
CSA Electrical Bulletin 556B - Electronic Instruments and Scientific Apparatus for Special Use and Applications.

VDE 0871/6.78 Level A - RFI Suppression of Radio Frequency Equipment for Industrial, Scientific, and Medical (ISM) and Similar Purposes.
VDE 0411 - Electronic Measuring Instruments and Automatic Controls.

DIMENSIONS:

See Figure 2-1.

WEIGHT:

Net: 5.4kg (12 lb) Shipping: 7.3kg (16 lb)



SECTION II INSTALLATION

2-1 INITIAL INSPECTION

2-2 Before shipment, this instrument was inspected and found to be free of mechanical and electrical defects. As soon as the instrument is unpacked, inspect for any damage that may have occurred in transit. Save all packing materials until the inspection is completed. If damage is found, file claim with carrier immediately. The Hewlett-Packard Sales and Service office should be notified as soon as possible.

2-3 Mechanical Check

2-4 This check should confirm that there are no broken knobs or connectors, that the cabinet and panel surfaces are free of dents and scratches, and that the meters are not scratched or cracked.

2-5 Electrical Check

2-6 Section V of this manual contains complete verification procedures for this instrument. Section III contains an abbreviated check which can be used quickly to place the unit into operation. Refer to the inside front cover of the manual for the Certification and Warranty statements.

2-7 REPACKAGING FOR SHIPMENT

2-8 To insure safe shipment of the instrument, it is recommended that the package designed for the instrument be used. The original packaging material is reusable. If it is not available, contact your local Hewlett-Packard Sales and Service office to obtain the materials. This office will also furnish the address of the nearest service office to which the instrument can be shipped. Be sure to attach a tag to the instrument specifying the owner, model number, full serial number, and service required, or a brief description of the trouble.

2-9 INSTALLATION DATA

2-10 The instrument is shipped ready for bench operation. Before applying power to the instrument, read paragraph 2-18.

2-11 Location and Cooling

2-12 This instrument is fan cooled and must be installed with sufficient space for cooling air flow between the sides and rear of the unit. It should be used in an area where the ambient temperature does not exceed $+55^{\circ}\text{C}$.

2-13 Outline Diagram

2-14 Figure 2-1 illustrates the outline shape and dimensions of the cabinet.

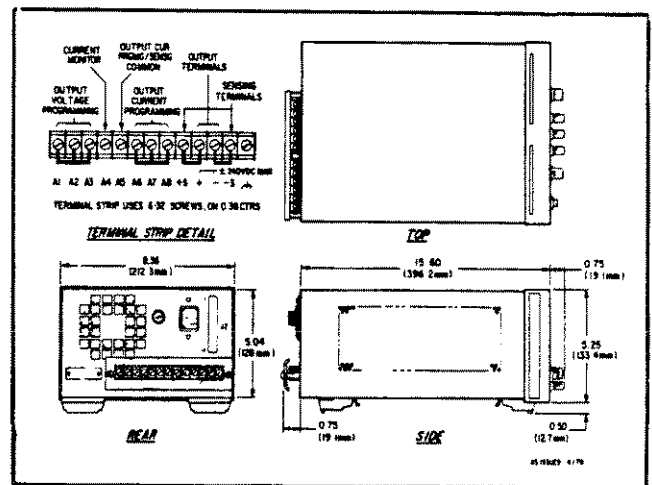

Figure 2-1. Outline Diagram

2-15 Rack Mounting

2-16 This supply can be rack mounted in a standard 19-inch rack panel either by itself or alongside another half (or quarter) width module. All rack mounting accessories for this unit are listed in paragraph 1-16. Complete installation instructions are included with each rack mounting kit.

2-17 Input Power Requirements

2-18 This supply may be operated from a nominal 120V, 220V or 240V single-phase ac power source (48-63Hz). The input voltage range and input current required for each of the nominal inputs are listed below. The maximum input power (at high line, full load) required for any input is 320 watts. A label on the rear panel indicates the nominal line voltage for which the instrument was set at the factory. If necessary, the user can convert the instrument from one line voltage option to another by following the instructions in paragraph 2-23.

<u>Nominal Voltage</u>	<u>Line Voltage Range</u>	<u>Maximum Input Current</u>
120V	104-127	5.3A rms
220V	191-233	2.9A rms
240V	208-250	2.7A rms

2-19 Power Cable

2-20 Model 6024A is shipped from the factory with a power-cord plug appropriate for the user's location. Figure 2-2 illustrates the standard configuration of power-cord plugs used by Hewlett-Packard. Below each drawing is the HP Part Number for a replacement power cord equipped with a plug of that configuration. If a different power cord is required, contact the nearest Hewlett-Packard Sales and Service office.

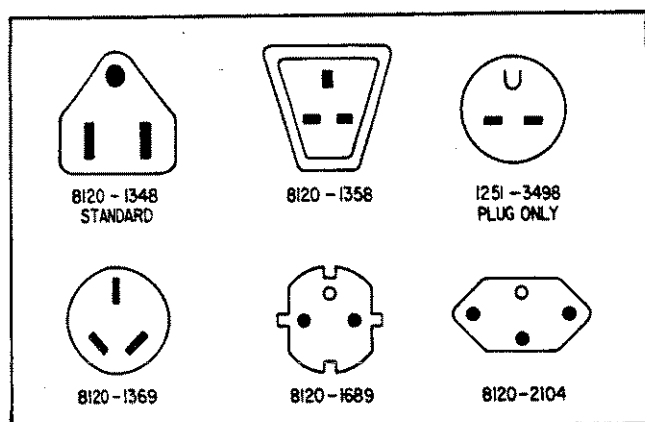

Figure 2-2. Power-Cord Plug Configurations

2-21 To protect operating personnel, the National Manufacturers Association (NEMA) recommends that the instrument panel and cabinet be grounded. This instrument is equipped with a three-conductor power cable; the third conductor is the ground conductor. When the cable is plugged into an appropriate receptacle the instrument is grounded. In no event shall this instrument be operated without an adequate cabinet ground connection.

2-22 The offset pin on the standard power cable three-prong connector is the ground connection. To preserve the protection feature when operating the

instrument from a two-contact outlet, use a parallel-ground adapter (if permitted by local regulations) and connect the green lead on the adapter to ground.

2-23 LINE VOLTAGE OPTION CONVERSION

2-24 Line voltage conversion is accomplished by adjusting three components; the two-section line select switch S2, line-voltage jumper W1, and rear-panel line fuse F1. To convert the supply from one line voltage option to another, proceed as follows:

- a. Disconnect line cord from power source.
- b. Remove top cover from instrument by removing four screws from cover (two on each side) and sliding cover to the rear.
- c. The line voltage select switch is located on left side of main board (as viewed from front) near front of instrument (see Figure 2-3). Use a small-blade screwdriver to set the two switch sections to match the pattern silkscreened on main board as shown in Figure 2-3. For example, to set switches for 120V operation (as illustrated), move forward switch section so that its white slot is toward front of instrument and move rearward switch section so its white slot is toward rear of instrument.
- d. The line voltage jumper W1 is located on main board near center rear (see Figure 2-4). (A dashed line is silkscreened on main board from vicinity of S2 to W1). Jumper must be soldered in place for 120V operation, and *must be removed for 220V or 240V operation.*
- e. Check rating of fuse F1 installed in rear-panel fuseholder and replace with correct value if necessary. Do not use slow-blow fuses. For 120V operation, use 6A fuse, HP Part Number 2110-0056. For 220V or 240V operation, use 4A fuse, HP Part Number 2110-0055. Fuse F2 on main board should be 0.5A, HP Part Number 2110-0202, for all input voltages.
- f. Replace covers and mark the supply clearly with a tag or label indicating correct line voltage to be used.

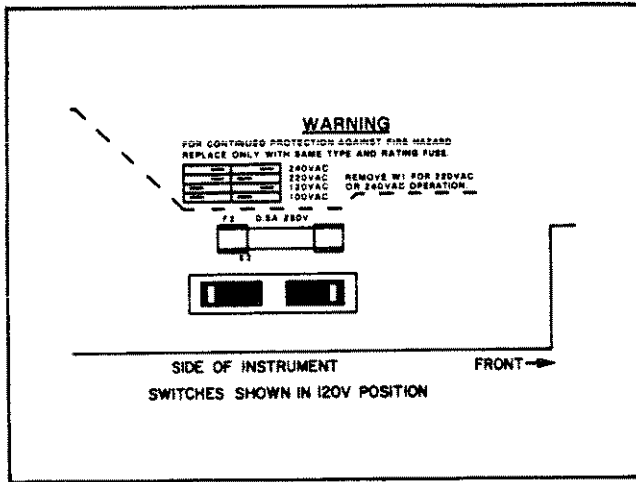

Figure 2-3. Line Voltage Select Switch

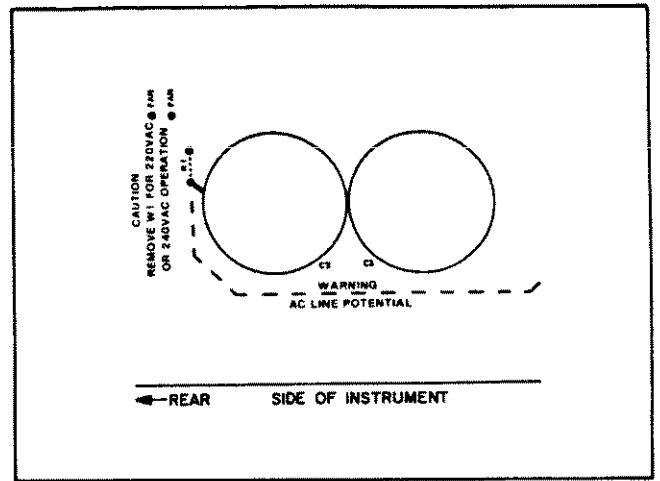

Figure 2-4. Location of Jumper W1



SECTION III OPERATING INSTRUCTIONS

3-1 INTRODUCTION

3-2 This section describes the operating controls and indicators, turn-on check-out procedures, and operating procedures and considerations for the Model 6024A.

WARNING

Before the instrument is switched on, all protective earth terminals, extension cords, auto-transformers and devices connected to it should be connected to a protective earth grounded socket. Any interruption of the protective earth grounding will cause a potential shock hazard that could result in personal injury.

Only fuses with the required current rating and specified type should be used. Do not use repaired fuses or short circuited fuseholders. To do so could cause a shock or fire hazard.

3-4 TURN-ON CHECKOUT PROCEDURE

3-5 The following checkout procedure describes the use of the front panel controls and indicators (see Figure 3-1) and ensures that the supply is operational. This check should be performed when the unit is first received. If the supply fails to perform properly, proceed to the troubleshooting procedures in Section V.

a. Ensure that rear terminal board straps are connected as shown in Figure 3-2, but do not connect load. Check that rear-panel label indicates unit is set for line voltage to be used. If it is not, refer to paragraph 2-23. If unit is equipped with System Option 002 ensure that option cable is disconnected from rear panel option connector before proceeding.

b. Ensure that CURRENT control (5) is rotated clockwise at least two turns and OVP ADJUST potentiometer (8) is fully clockwise.

c. Press pushbutton LINE switch (1) to ON (pushbutton in) and observe that reflective indicator shows in the LINE switch and that fan operates.

d. Turn VOLTAGE control (2) through output voltage range of unit as indicated on voltmeter (4).

VOLTAGE light (3) should be lit across entire range indicating that supply is in constant voltage mode.

e. Check out overvoltage circuit by turning OVP ADJUST control (8) (screwdriver adjust) counter-clockwise until unit shuts down. Output voltage should drop to -0.6 to 0 volts and OVP (9) and UNREGULATED (10) indicators should light.

f. Reset overvoltage circuit by returning OVP control to maximum clockwise position and turning supply off for at least one second and then back on. Output voltage should return to value set in step d.

g. To check constant current circuit, turn off supply and connect short (AWG #18 or larger) across + and - output terminals (11 and 12 on front panel or + and - on rear panel). Ensure that VOLTAGE control is rotated at least two turns clockwise.

h. Turn supply back on and rotate CURRENT control (5) through output current range of unit as indicated on ammeter (7). CURRENT light (6) should be on across entire range indicating that supply is in constant current mode.

i. Turn off supply, remove short from output, and read remainder of operating instructions before connecting actual load to supply.

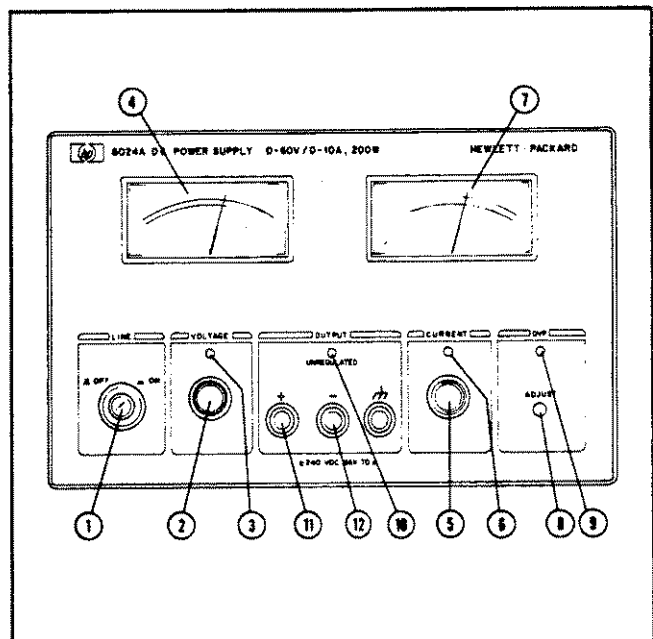

Figure 3-1. Front Panel Controls and Indicators

3-6 OPERATING MODES

3-7 This power supply is designed so that its mode of operation can be selected by making strapping connections on its rear panel. Normal operating mode for this power supply uses local programming of the output voltage and current via the front panel VOLTAGE and CURRENT controls, and local sensing of the output voltage. Alternate operating modes allow use of remote programming, remote sensing, and multiple power supply combinations.

3-8 The following paragraphs first describe operating considerations with the normal operating mode, using the strapping pattern as it is connected at the factory. Later paragraphs cover alternate operating modes. The operating considerations described with normal mode, such as constant voltage/constant current crossover, overrange, constant voltage and constant current operation, overvoltage protection, protective circuits, and load connections, apply to the alternate modes as well as to normal mode. More theoretical descriptions regarding the operational features of power supplies in general are given in the DC Power Supply Handbook, Application Note 90B (available at no charge from your local Hewlett-Packard Sales Office).

3-9 NORMAL OPERATING MODE

3-10 The power supply was shipped with the proper rear panel strapping connections made for constant voltage/constant current operation with local sensing and local programming. This strapping pattern is illustrated in Figure 3-2. By means of the front panel voltage and current controls, the operator selects either a constant voltage or a constant current output as described in paragraphs 3-17 or 3-19. Whether the supply functions in the constant voltage or constant current mode depends on the settings of the VOLTAGE and CURRENT controls and on the value of the load resistance.

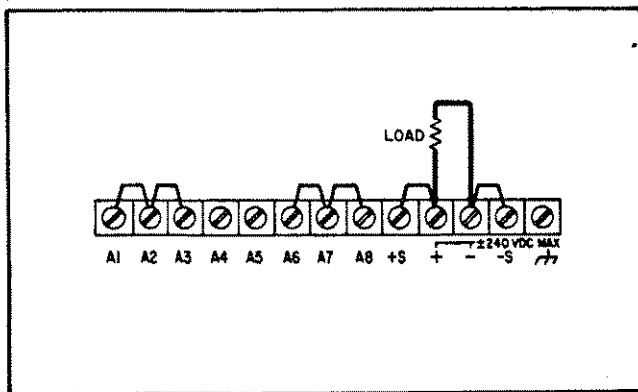

Figure 3-2. Normal Strapping

3-11 Figure 3-3 shows the overall output range of the supply, with three sample operating loci. Locus 1 is established with a VOLTAGE setting of 20V and a CURRENT setting of 3A. For any values of load resistance greater than the crossover value of 6.7 ohms, the supply operates in constant voltage mode. For values of load resistance less than the crossover value, the supply operates in constant current mode. The transition occurs smoothly and automatically; no switches need be operated or connections changed. The front panel VOLTAGE and CURRENT lights indicate which mode is operating.

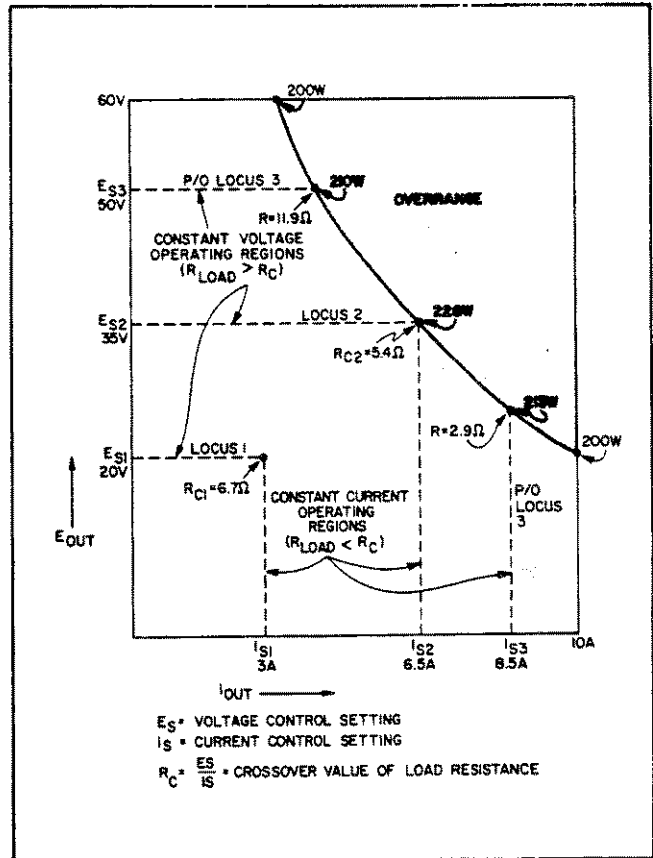

Figure 3-3. Overall Output Range with Three Sample Operating Loci

3-12 Locus 2 is established with a VOLTAGE setting of 35V and a CURRENT setting of 6.5A. Its crossover load resistance is 5.4 ohms, and lies on the rated-output-power boundary.

3-13 A rectangular operating locus will be established for all voltage and current settings within the rated-output-power boundary. However, if the VOLTAGE and CURRENT controls are set so that the boundary can be exceeded, as in locus 3, the supply will go into overrange if the load resistance falls within a critical band (refer to next paragraph).

3-14 Overrange. The supply will be driven into overrange (shaded area of Figure 3-3) if the **VOLTAGE** and **CURRENT** controls are set above the output power rating and the load resistance falls within a critical band. For example, assume that the operator sets the **VOLTAGE** control at 50V and the **CURRENT** control at 8.5A, as in locus 3 on Figure 3-3. For all load resistances above 11.9 ohms (which is the critical value) the supply would operate normally in the constant voltage mode. If the load resistance were to fall much below 11.9 ohms, however, the supply would be forced into overrange. If the load resistance continued to decrease to a 2.9 ohm value, the supply would automatically come out of overrange and into the constant current mode at the 8.5A, 25V point. (The supply will probably go out of regulation while operating in the overrange region, refer to paragraph 3-16.)

3-15 Anytime the supply operates in overrange, the **VOLTAGE** and **CURRENT** indicators turn off and the **UNREGULATED** indicator lights. The **VOLTS** and **AMPERES** meters indicate the voltage and current being supplied to the output. (The product of the two readings will exceed 200 watts.) Paragraph 3-30 identifies conditions other than overrange which cause the **UNREGULATED** indicator to light.

3-16 The supply can operate in the overrange region (beyond the rated-output-power boundary) for sustained periods without being damaged. However, the supply is not guaranteed to meet specifications in overrange. Output ripple increases substantially and regulation is seriously degraded. As an operator aid, the maximum available load current for each constant voltage setting is indicated on a secondary scale of the voltmeter. Similarly, the maximum available load voltage for each current setting is indicated on the ammeter.

NOTE

*Under certain conditions of line and load, it is possible for the supply to provide more than rated output power and still maintain regulation. If this occurs, the unit will operate normally and the **UNREGULATED** indicator will be off. However, the slightest change in either line or load may cause the unit to go out of regulation. Operation of the unit beyond the rated-output-power boundary is not recommended under any circumstances.*

3-17 Constant Voltage Operation

3-18 To adjust the supply for constant voltage operation:

a. Turn on supply and, with output terminals open, adjust the **VOLTAGE** control for the desired output voltage. Then turn power off.

b. Connect a short across the front or rear panel + and — output terminals, restore power, and adjust the **CURRENT** control for the desired maximum output current. Then turn power off and remove the short. If a load change causes this current limit to be exceeded, the supply automatically crosses over to constant current operation at this preset current limit and the output voltage drops proportionately. In setting the current limit, make an adequate allowance for high peak currents that could cause unwanted crossover.

3-19 Constant Current Operation

3-20 To adjust the supply for constant current operation, with supply turned off:

a. Connect a short across the front or rear panel + and — output terminals, turn the power on, and adjust the **CURRENT** control for the desired output current.

b. Open the output terminals and adjust the **VOLTAGE** control for the desired maximum output voltage. If a load change causes this voltage limit to be exceeded, the supply automatically crosses over to constant voltage operation at this preset voltage limit and the output current drops proportionately. In setting the voltage limit, make an adequate allowance for high peak voltages that could cause unwanted crossover.

3-21 Overvoltage Protection

3-22 Adjustment. The overvoltage trip point is adjusted with the **OVP ADJUST** screwdriver control on the front panel. The approximate trip voltage range for this unit is from two volts to 64V. When the overvoltage protection (**OVP**) circuit trips, the supply is inhibited and delivers no output power; the **OVP** and **UNREGULATED** indicators on the front panel light. Rotating the control clockwise sets the trip voltage higher. (It is set to maximum at the factory.)

3-23 When adjusting the **OVP** trip point, the possibility of false tripping must be considered. If the trip voltage is set too close to the supply's operating voltage, a transient in the output would falsely trip the **OVP**. For this reason it is recommended that the **OVP** trip voltage be set higher than the output voltage by at

least 1.5 volts. To adjust the OVP trip voltage, proceed as follows:

- a. With OVP ADJUST potentiometer fully CW, no load connected; turn on supply.
- b. Set output VOLTAGE control to desired trip voltage.
- c. Turn OVP ADJUST pot CCW until OVP circuit fires; red OVP indicator lights and output voltage falls to zero.
- d. Turn off supply and turn down output voltage.
- e. Turn supply back on and set desired output voltage.

3-24 Resetting the OVP Circuit. If the OVP circuit trips during normal operation, the ac LINE switch must be turned off for at least one second and then back on to reset the circuit. If the OVP circuit trips continuously check the load and/or the trip point setting. If the supply does not operate properly after the OVP circuit is reset, proceed to troubleshooting in Section V.

3-25 CONNECTING THE LOAD

3-26 To satisfy the requirements of safety, the wires to the load should be at *least* heavy enough not to over-heat while carrying the power supply current that would flow if the load were shorted. Stranded AWG#16 wire is rated for 12.7A at 105°C conductor temperature (45°C rise above 60°C ambient temperature). Stranded AWG #14 wire is rated for 14.8A at 80°C conductor temperature (20°C rise above 60°C ambient temperature). These ratings are based on use of a twisted pair to connect the load to the supply. *Generally, heavier wire is required to obtain good regulation at the load. If the load regulation is critical, use remote voltage sensing. (Refer to paragraph 3-34).*

3-27 If multiple loads are connected to one supply, each load should be connected to the supply's output terminals using separate pairs of connecting wires. This minimizes mutual coupling effects between loads and takes full advantage of the supply's low output impedance. Each pair of connecting wires should be as short as possible and twisted or shielded to reduce noise pickup.

3-28 If load considerations require the use of output distribution terminals that are located remotely from the supply, then the power supply output terminals should be connected to the remote distribution terminals by a pair of twisted or shielded wires and each load should be separately connected to the remote distribution terminals. Remote voltage sensing is required under these circumstances (paragraph 3-34).

3-29 Either positive or negative voltages can be obtained from this supply by grounding one of the output terminals or one end of the load. Always use

two wires to connect the load to the supply regardless of where or how the system is grounded. Never ground the system at more than one point. This supply can be operated with either output terminal up to ± 240 volts dc from ground.

3-30 PROTECTIVE CIRCUITS

3-31 Protective circuits within the instrument may limit or turn off the output in case of abnormal conditions. The cause for the protective action can be determined by observing the front panel indicators (lights and meters). An overrange condition is indicated by the UNREGULATE indicator on, the VOLTS and AMPERES meters reading relatively high, and the VOLTAGE, CURRENT, and OVP indicators off. An overvoltage condition is indicated by both the OVP and UNREGULATED indicators on, the meters reading near zero, and the VOLTAGE and CURRENT indicators off. An overtemperature condition is indicated by the UNREGULATED indicator on, the VOLTAGE, CURRENT, and OVP indicators off, and the meters dropping toward zero from the readings that existed when the overtemperature condition occurred. If the primary power voltage drops below approximately 70% of nominal, the level detector will shut down the instrument. In this case, the UNREGULATED indicator is on, the VOLTAGE, CURRENT, and OVP indicators are off, and the meters read zero immediately.

3-32 ALTERNATE OPERATING MODES

3-33 The alternate operating modes discussed in the following paragraphs include: remote voltage sensing, remote programming, auto-parallel operation, auto-series operation, and auto-tracking operation. By changing the rear panel strapping pattern according to the instructions which follow, the supply can be operated in any of the modes listed above.

WARNING

Disconnect input ac power before changing any rear panel connections and make certain all wires and straps are properly connected and terminal strip screws are securely tightened before reapplying power.

3-34 Remote Voltage Sensing

3-35 Because of the unavoidable voltage drop developed in the load leads, the normal strapping pattern shown in Figure 3-2 will not provide the best possible voltage regulation at the load. The remote sensing connections shown in Figure 3-4 improve the voltage regulation at the load by monitoring the voltage there instead of

at the supply's output terminals. (The advantages of remote sensing apply only during constant voltage operation.) When using remote sensing, turn off the power supply before changing the rear panel straps, sense leads, or load leads. The following paragraphs discuss some precautions that should be observed when making a remote sensing installation.

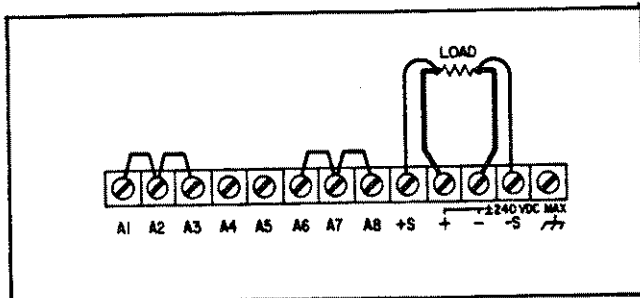

Figure 3-4. Remote Sensing

3-36 The load leads should be of the heaviest practicable wire gauge, at least heavy enough to limit the voltage drop in each lead to 0.5 volts. The power supply has been designed to minimize the effects of long load lead inductance, but best results will be obtained by using the shortest load leads practical.

NOTE

Because the OVP circuit monitors voltage at the rear terminals and there is an unavoidable voltage drop in the load leads, it may be necessary to readjust the OVP trip point in remote sensing mode.

3-37 Since the sensing leads carry only a few milliamperes, the wires used for sensing can be much lighter than the load leads (AWG #22 is generally adequate), but they should be a shielded, twisted pair to minimize the pickup of external noise. Any noise picked up on the sensing leads will appear at the supply's output, and CV load regulation may be adversely affected. The shield should be grounded at one end only and should not be used as one of the sensing conductors. The sensing leads should be connected as close to the load as possible.

3-38 The sensing leads are part of the supply's programming circuit, so they should be connected in such a way as to make it unlikely that they might inadvertently become open circuited. It is recommended that no switch, relay, or connector contacts be included in the remote sensing path.

NOTE

If the + output lead opens, the load voltage (+ sense to - output) will remain regulated at the set value, but the output voltage of the supply will rise to some high value dependent on the control settings and the load. If this voltage exceeds the OVP voltage, the OVP trips and down-programs the output voltage to zero volts. Whether or not the OVP trips, neither the supply nor the load will be damaged by excessive voltage.

If the - output lead opens, the load voltage (+ output to - sense) will drop to some low value and the output voltage of the supply operates at some value between zero and seven volts, both depending on the control settings and the load.

3-39 Remote Programming

3-40 The output voltage and/or current of the power supply can be remotely controlled by external resistance, voltage, or current sink. Programming can be accomplished via the standard rear-panel screw-on terminals or via the option connector on units equipped with System Option 002. Standard programming is described in this section; programming with System Option 002 is described in Appendix A.

3-41 For resistance programming, a variable resistor can control the output over its entire range. Or, a variable resistor connected in series and/or parallel with a fixed resistor can have its control restricted to a limited portion of the output range. Alternately, a switch can be used to select fixed values of programming resistance to obtain a set of discrete voltages or currents. (The switching configuration used may require make-before-break contacts to avoid producing the output voltage transients caused by momentarily opening the programming terminals.) To maintain the temperature and stability specifications of the supply, any resistors used for programming must be stable, low-noise resistors with a temperature coefficient of less than 25ppm per °C and a power rating at least 30 times what they will actually dissipate.

3-42 Both voltage and current outputs can also be controlled by a voltage source. A voltage source of 0 to 5 volts programs the output from zero to full scale.

Voltage sources of more than 5 volts can be scaled down to the proper range.

3-43 Current programming of both voltage and current outputs is possible also. With current programming, the supply's own constant current sources are used to provide current through an external resistance. A controllable current sink, such as a DAC, in parallel with the external resistor sinks a controllable percentage of the current around the resistance. The remaining current flows through the external resistance and develops a voltage that programs the power supply.

3-44 Connecting a supply for remote voltage or current programming disables the corresponding front-panel controls.

3-45 The following paragraphs discuss in greater detail the methods of remotely programming the output voltage or current using either a resistance, voltage, or current input. Whichever method is used, the wires connecting the programming terminals of the supply to the remote programming device must be shielded to reduce noise pickup. The outer shield of the cable should not be used as a conductor, and should be connected to ground at one end only.

3-46 Although the following connection drawings (Figures 3-5 through 3-12) show the supply strapped for local sensing, remote programming and remote voltage sensing do not interact and may be used simultaneously.

3-47 **Constant Voltage Output, Resistance Control.** The rear panel connections shown in Figure 3-5 allow the output voltage to be varied by using an external resistor to program the supply. A programming resistor variable from 0 to 2500 ohms produces a proportional output voltage from zero to full scale. Note that fixed resistors may be connected in series and/or in parallel with the variable programming resistor to set lower and/or upper output voltage limits. The resultant programming resistance is the sum of the series/parallel resistor combination, and must be between 0 and 2500 ohms. For example, a 1250 ohm resistor connected in series with the variable programming resistor will set the lower limit for output voltage at one-half full scale, i.e., 30 volts.

NOTE

If the programming terminals (A2 to -S) become open circuited during resistance programming, the output voltage will tend to rise above rating. The supply will not be damaged if this occurs, but the over-voltage trip point should be properly adjusted to protect the user's load.

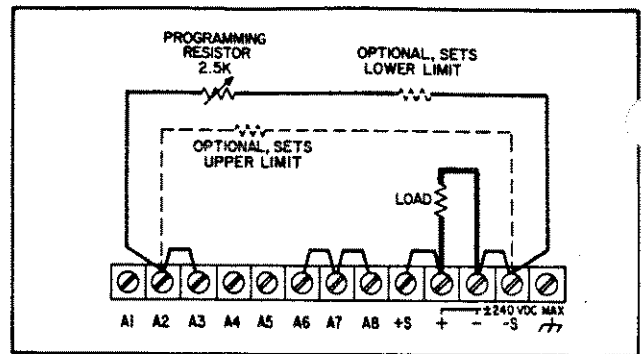

Figure 3-5. Resistance Programming of Output Voltage

3-48 **Constant Voltage Output, Voltage Control.** The rear panel connections shown in Figure 3-6 allow the output voltage to be varied by using an external voltage source to program the supply. A voltage source variable from 0 to +5 volts produces a proportional output voltage from zero to full scale. The load on the programming voltage source is less than 5µA.

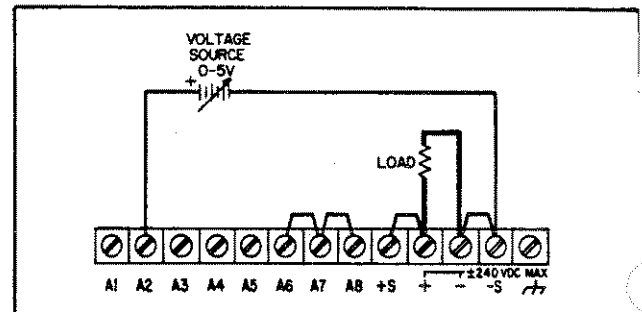

Figure 3-6. Voltage Programming of Output Voltage

3-49 **Constant Voltage Output, Scaled Voltage Control.** The rear panel connections shown in Figure 3-7 allow the output voltage to be varied by using an external voltage source of more than 5 volts to program the supply. The ratio of the resistance values in the voltage divider must be selected so that the voltage at the center tap of the divider, A2, varies from 0 to 5 volts as the programming voltage source varies from zero to maximum.

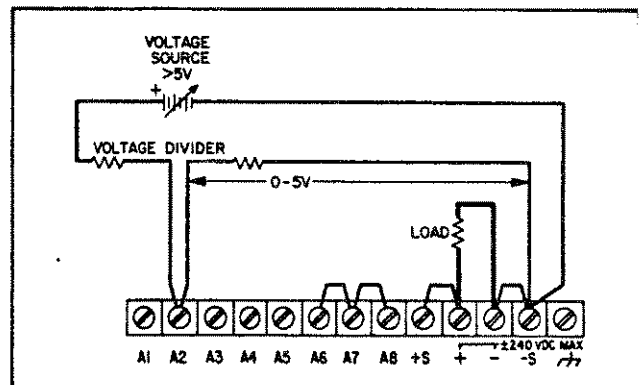

Figure 3-7. Scaled Voltage Programming of Output Voltage

3-50 The total resistance of the voltage divider should be as small as practical without excessively loading the external voltage source. This minimizes degrading the programming speed, offset, and drift specifications. For example, a total resistance of 7.5K will approximately double the up-programming time. A total resistance of less than 5K will make the degradation unnoticeable in most applications.

3-51 Constant Voltage Output, Current Control. The rear panel connections shown in Figure 3-8 allow the output voltage to be varied by using an external current sink to program the supply. In this configuration the supply's own constant current source is used to develop a voltage across a resistor. A current sink, such as a DAC, connected in parallel with the resistor sinks part or all of the current, and thereby determines the voltage developed across the resistor. A current sink variable from 2 mA to 0 mA produces an inversely proportional output voltage from zero to full scale. Many DACs include a sign-change bit, so that a zero digital input to the DAC will produce a 0 volt output from the power supply, and a maximum digital input to the DAC will produce a full scale output from the power supply. Note that the VOLTAGE control potentiometer can be used in place of the external resistor by connecting A1 to A2 in addition to the connections shown in Figure 3-8.

CAUTION

If the DAC is turned off or the program leads open, the output voltage will tend to rise above rating. The supply will not be damaged if this occurs, but the over-voltage trip point should be properly adjusted to protect the user's load.

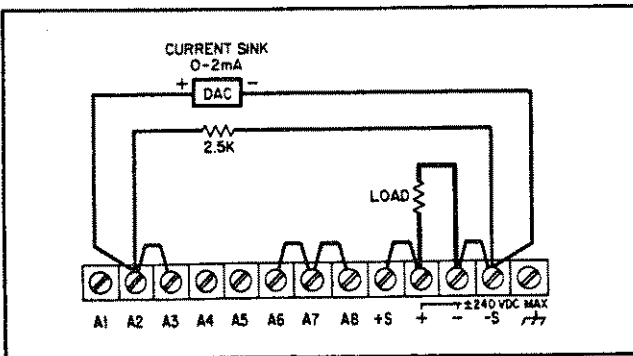

Figure 3-8. Current Programming of Output Voltage

3-52 Constant Current Output, Resistance Control. The rear panel connections shown in Figure 3-9 allow the output current to be varied by using an external resistor to program the supply. The discussion in paragraph 3-47 for constant voltage operation also applies for constant current operation.

CAUTION

If the programming terminals (A7 to A5) become open circuited during resistance programming, the output current will tend to rise above rating. The supply will not be damaged if this occurs, but the user's load may be damaged. If there is a possibility that the programming leads may be opened, it is suggested that the optional resistor be connected directly across terminals A5 and A7, as shown in Figure 3-9. The value of this resistor should be selected to limit the output current to the maximum that the load can handle without damage. For example, if the load can handle 5 amperes (one-half of full scale), a 1250 ohm resistor should be connected from A5 to A7. Of course, if this resistor is used, the resistance value actually programming the supply is the parallel combination of the programming resistor and the optional resistor.

3-53 Constant Current Output, Voltage Control. The rear panel connections shown in Figure 3-10 allow the output current to be varied by using an external voltage source to program the supply. The discussion in paragraph 3-48 for constant voltage operation also applies for constant current operation.

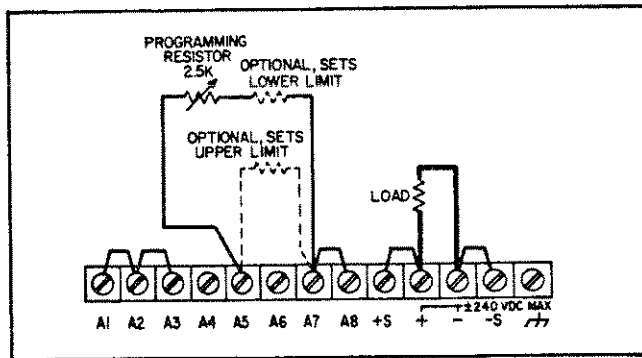

Figure 3-9. Resistance Programming of Output Current

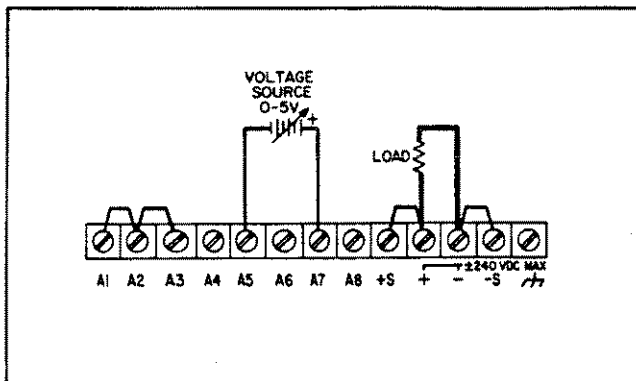

Figure 3-10. Voltage Programming of Output Current

3-54 Constant Current Output, Scaled Voltage Control.

The rear panel connections shown in Figure 3-11 allow the output current to be varied by using an external voltage source of more than 5 volts to program the supply. The discussion in paragraphs 3-49 and 3-50 for constant voltage operation also applies for constant current operation.

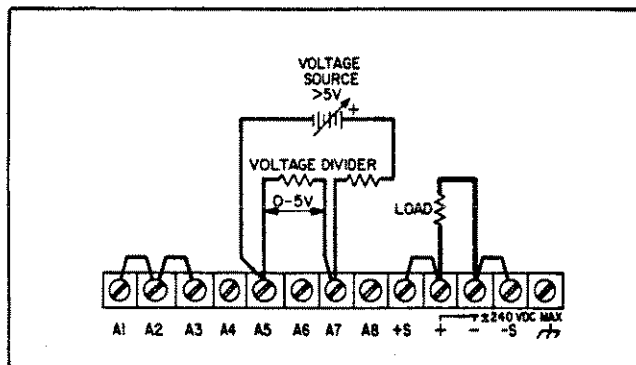

Figure 3-11. Scaled Voltage Programming of Output Current

3-55 Constant Current Output, Current Control.

The rear panel connections shown in Figure 3-12 allow the output current to be varied by using an external current sink to program the supply. The discussion in paragraph 3-51 for constant voltage operation also applies for constant current operation, except that the CURRENT control can be used in place of the external resistor by connecting A6 to A7 in addition to the connections shown in Figure 3-12.

CAUTION

If the DAC is turned off or the program leads open, the output current will tend to rise above rating. The supply will not be damaged if this occurs, but the VOLTAGE control should be adjusted such that the supply will switch to CV mode once the output current reaches the highest level the load can absorb and/or the OVP ADJUST should be set to shut down the supply.

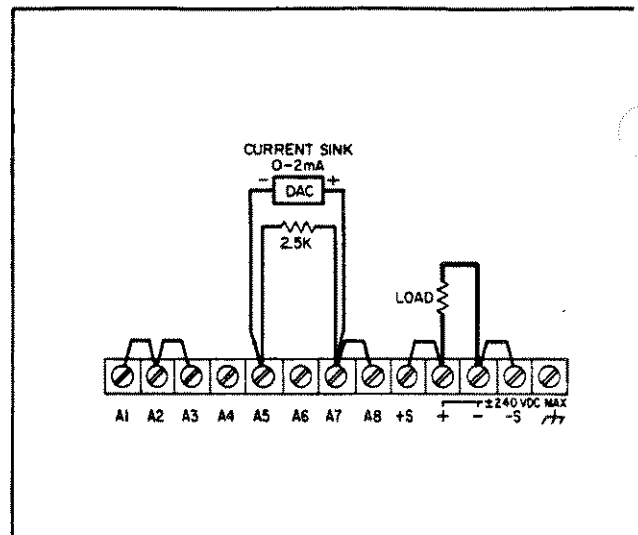

Figure 3-12. Current Programming of Output Current

3-56 Auto-Parallel Operation

3-57 Figure 3-13 shows the rear panel interconnection required to auto-parallel two or more units. This mode of operation provides a greater current capability than can be obtained from a single supply, while ensuring that each supply will share the load proportionally to its own total power capability under all load conditions. For example, if a 200W supply and a 1000W supply were auto-parallelled, the 200W supply would provide 1/6 the total current and the 1000W supply would provide 5/6 the total current. The 6024 can be auto-parallelled only with other autoranging units, or with units that have current-monitoring output signals that are internally referenced to the -output and equal to 5V at maximum rated current output. Up to eight supplies may be connected in auto-parallel.

NOTE

Use wires of equal length and gauge to connect each auto-parallelled supply to the load. Load sharing will not be equal unless the leads connecting each supply to the load are equal in resistance. If it is impractical to run leads from each supply to the load because of distance between the supplies and the load, leads of equal length should be run from each supply to common distribution terminals, with a single pair of leads run from the distribution terminals to the load.

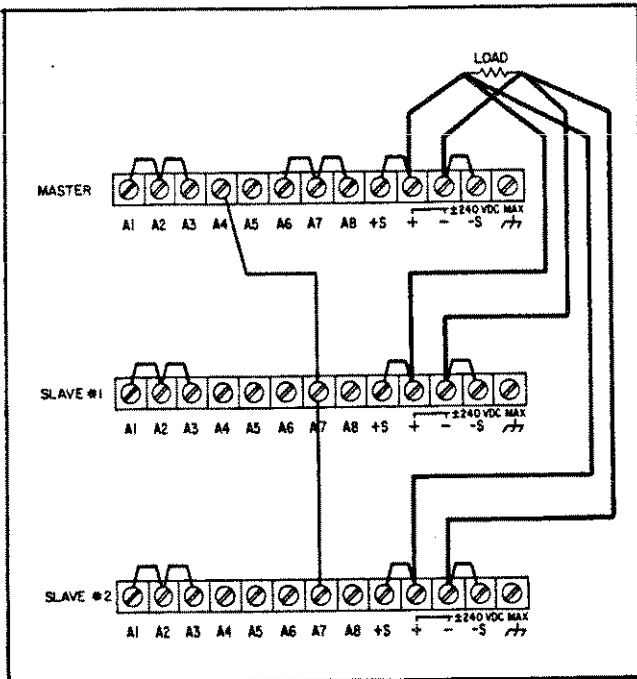

Figure 3-13. Auto-Parallel Operation

3-58 Setting the Voltage and Current Controls.

The auto-parallel combination of supplies behaves as if it were a single constant voltage/constant current supply controlled by the voltage and current controls of the master supply. The current controls of the slaves are disabled. The voltage controls of the slaves should be set above the desired output voltage to avoid interference with the master.

NOTE

The voltage controls of the slave supplies can be disabled by disconnecting the straps between the A1 and A2 terminals and connecting a resistor between A2 and -S on each slave. The resistor value should be chosen to program a voltage higher than the desired output voltage. (See paragraph 3-47.)

3-59 Overvoltage Protection in Auto-Parallel.

Adjust the OVP trip point at the master supply. The slave supply OVP control(s) may be set to the same level or to maximum (fully clockwise) to disable them. If the master supply OVP trips, the master will program the slaves to zero output. If a slave OVP trips, it shuts down only that slave; the other units supply more current until the master switches to CC mode.

3-60 Auto-Parallel with Remote Sensing.

To combine auto-parallel operation with remote sensing,

connect the supplies as described above but remove the +S and -S jumpers from the master supply and connect the +S and -S terminals directly to the + and - ends of the load. Observe the precautions outlined under paragraph 3-34.

3-61 Auto-Parallel with Remote Programming.

The output voltage and/or current of an auto-parallel combination can be remotely programmed. Remote programming connections are made to the master supply. Observe all precautions outlined in the remote programming paragraphs. Simultaneous use of remote sensing and remote programming is also possible during auto-parallel operation.

NOTE

Because only the master can down-program the output of an auto-parallel combination, down-programming speed will be reduced under no-load conditions.

3-62 Auto-Series Operation

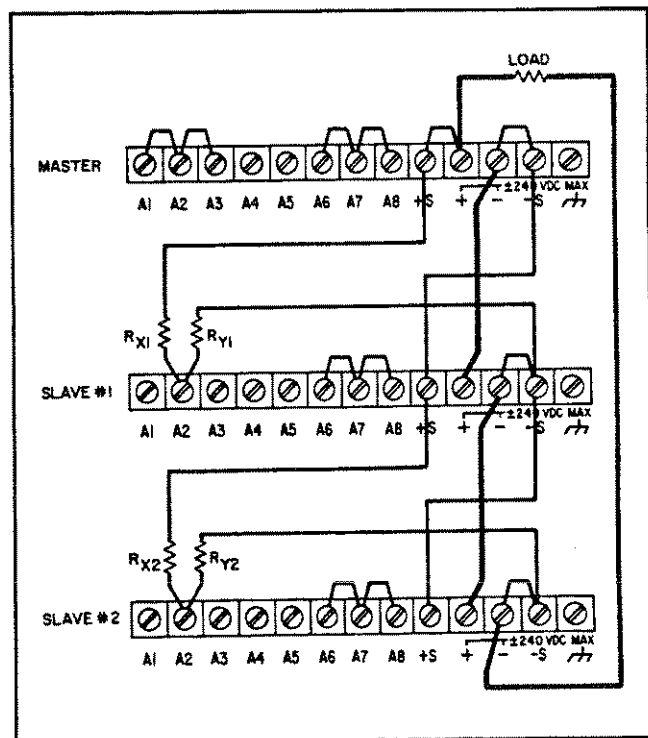

Figure 3-14. Auto-Series Operation

3-63 Figures 3-14 and 3-15 show the rear-panel interconnections required to operate two or more supplies in auto-series. This mode of operation provides a greater voltage capability than can be obtained from a single supply. As many as four supplies can be

connected in auto-series in the configuration shown in Figure 3-14, and as many as eight supplies can be connected if the power supply combination and load are center-tapped as in Figure 3-15 (with no more than four supplies on each side of the center tap). Either configuration allows all the supplies to be programmed simultaneously by the voltage and current controls of the master supply. The master supply must always be the one at the positive end of the series combination. Any point of the output can be grounded if desired, as long as no other point in the output is more than 240 volts from ground.

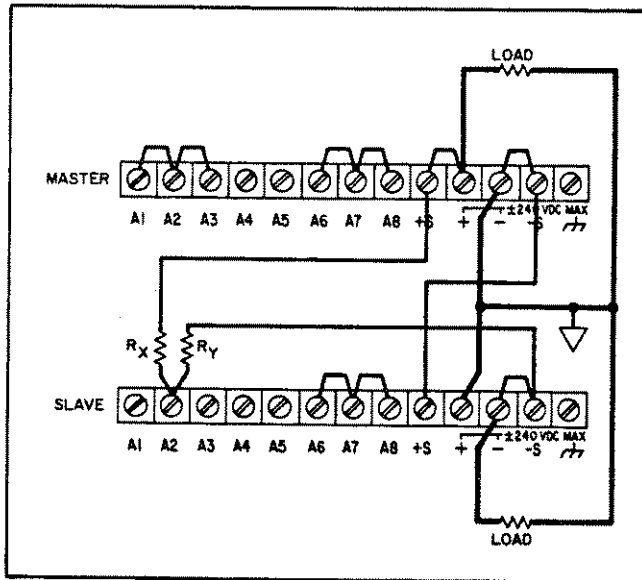

Figure 3-15. Auto-Series Operation, Positive and Negative Outputs

3-64 The output voltage of each slave supply varies in direct proportion to that of the master. The ratio of each slave's output voltage to the master's is established by the ratio of the resistors in the voltage divider connected between the + Sense of the master and the -Sense of the slave.

3-65 Any power supply capable of auto-series operation can be used in the auto-series combination. The supply with the lowest current rating limits the maximum output current of the combination. Any well-regulated, variable-output supply can be used as the master.

3-66 In applications in which coordinated positive and negative voltages are required, center tapping the supply combination and load as shown in Figure 3-15 allows simultaneous proportional control of both supply voltages.

CAUTION

If more than four supplies are connected together in an auto-series combination, be certain that neither the more positive end nor the more negative end of the auto-series combination is more than 240 volts from ground.

3-67 **Setting the Voltage and Current Controls.** The auto-series combination of supplies behaves as if it were a single constant voltage/constant current supply controlled by the voltage and current controls of the master supply. The voltage controls of the slaves are disabled. The current controls of the slaves should be set above the desired output current to avoid having a slave switch to CC mode.

NOTE

The current controls of the slave supplies can be disabled by disconnecting the straps between the A6 and A7 terminals and connecting a resistor between A7 and A5 on each slave. The resistor value should be chosen to program a current greater than the desired output current. (See paragraph 3-52.)

3-68 **Resistor Values.** As shown, each slave has an external voltage divider, R_X and R_Y , that determines its programming voltage. The ratio of R_Y to R_X determines the ratio of the slave output voltage to the master output voltage. To determine the values of R_Y and R_X , first choose the ratio of the slave output voltage to the master output voltage ($\frac{V_M}{V_S}$), select a value for R_Y , and then determine the value for R_X by solving this equation: $R_X = 12 (R_Y) (1 + \frac{V_M}{V_S}) - R_Y$. For example, assume a two-supply combination that is to provide 90 volts, 50 volts from the master and 40 volts from the slave. If we select a value of 1k for R_Y , the equation becomes:

$$R_X = 12 (1000) (1 + \frac{50}{40}) - 1000$$

$$R_X = 12,000 (2.25) - 1000$$

$$R_X = 26,000$$

3-69 Note that the slave output voltage may be lower than, equal to, or higher than the master output voltage.

3-70 Two factors must be considered when selecting the resistance value of R_Y : the effect on programming specifications, particularly speed, and the power that the resistor will have to dissipate. In the previous example, with a total resistance of 27k across an output of 90 volts, R_X will have to dissipate 290 milliwatts and R_Y will have to dissipate slightly more than 11 milliwatts. Lower resistance values of R_X and R_Y will increase programming speed while increasing the amount of power that R_X and R_Y will have to dissipate.

3-71 To maintain the temperature coefficient and stability specifications of the supplies, R_X and R_Y must be stable, low-noise resistors with temperature coefficients of less than 25 ppm per °C and power ratings of at least 30 times what they will actually dissipate.

3-72 The front-panel VOLTAGE control of the slave can be used in place of R_Y by connecting a strap from A2 of the slave to A1 of the slave. This enables the user to vary the percentage of the total voltage contributed by the slave. For calculation purposes, use a resistance value of 2.7k for the VOLTAGE control when it is set to maximum.

3-73 **Overvoltage Protection in Auto-Series.** Set the OVP in each supply so that it trips at a level higher than the voltage that supply will contribute. If the master supply OVP trips, the master will program the slaves to zero output. If a slave OVP trips, that slave and all slaves between it and the negative end of the series will go to zero output; all units more positive than the tripped slave (which includes the master) will continue to supply their set output voltage. Therefore, the total output voltage of the auto-series combination will be the sum of the outputs from the master plus any slaves between the master and the tripped slave. For maximum protection against overvoltage, set each unit's OVP slightly higher (≈ 1.5 volts) than the voltage it will contribute. For maximum protection against false tripping, set the slave OVPs to maximum and adjust OVP at the master.

3-74 **Auto-Series with Remote Sensing.** To combine auto-series operation with remote sensing, connect the supplies as described above but remove the +S jumper from the master supply and the -S jumper from the most negative supply, and connect the +S and the -S terminals directly to the + and - ends of the load.

3-75 The output voltage and/or current of an auto-series combination can be remotely programmed. Remote programming connections are made to the master supply. The percentage of the total voltage contributed by a

slave can also be remotely programmed by connecting a variable resistor to the slave in place of R_Y . Observe all precautions outlined in the remote programming paragraphs. Simultaneous use of remote sensing and remote programming is also possible during auto-series operation.

3-76 Auto-Tracking Operation

3-77 Figure 3-16 shows the interconnections required to operate two or more units in auto-tracking mode. This mode of operation allows multiple supplies that share a common negative (or positive) output bus to power separate loads and have their output voltages simultaneously programmed by the voltage and current controls of the master supply. The output voltage of each slave supply varies in direct proportion to that of the master. The ratio of each slave's output voltage to the master's is established by the ratio of the resistors in the voltage divider connected between the +S of the master and the -S of the slave.

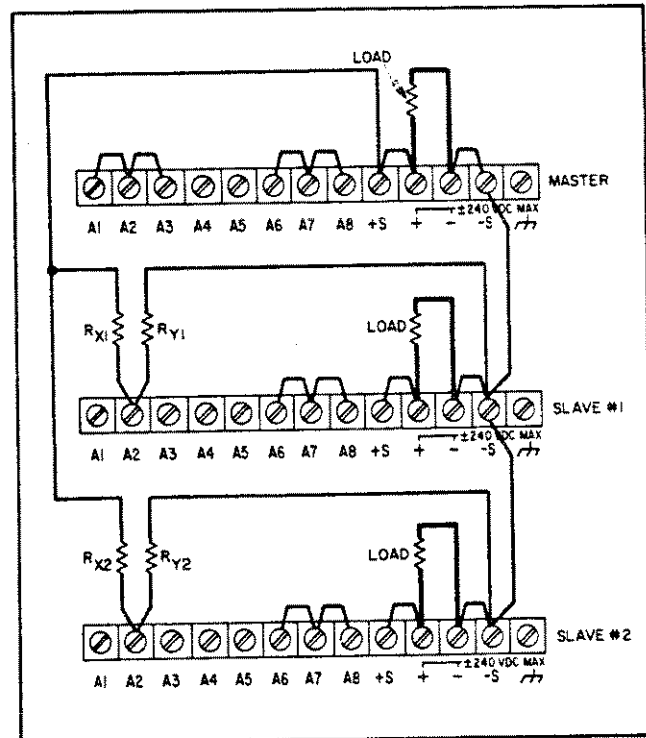

Figure 3-16. Auto-Tracking Operation

3-78 Figure 3-17 shows the interconnections required to provide both positive and negative outputs from an auto-tracking combination. As can be seen, the only difference from standard auto-tracking operation is that the + Out terminal of slave #2 instead of the - Out terminal is connected to the common bus. There is no limit to the number of supplies that can be operated in either auto-tracking configuration.

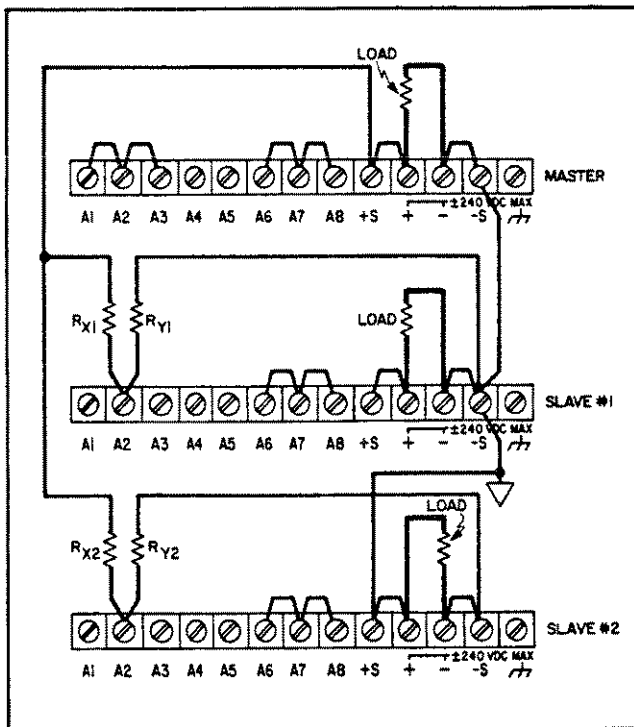

Figure 3-17. Auto-Tracking Operation, Positive and Negative Outputs

3-79 Resistor Values. The method for determining the values of R_X and R_Y in Figure 3-16 is similar to that given in paragraph 3-68 for auto-series mode. First choose the ratio of the slave output voltage to the master output voltage, select a value for R_Y , and then determine the value for R_X by solving the equation:

$$R_X = R_Y \left[\left(12 \frac{V_M}{V_S} \right) - 1 \right]$$

3-80 For example, assume a two-supply configuration in which the slave output is to vary from 0 to 50 volts while the master output varies from 0 to 30 volts. If we select a value of 1k for R_Y , the equation becomes:

$$R_X = 1000 \left[\left(12 \frac{30}{50} \right) - 1 \right]$$

$$R_X = 1000 [7.2 - 1]$$

$$R_X = 6200$$

3-81 The same factors that govern the choice of R_Y in auto-series mode apply in auto-tracking mode.

3-82 Repeat the process for each slave, with each slave referenced to the same (master) supply (unlike auto-series mode). Note that the slave output voltage may be lower than, equal to, or higher than the master output voltage.

3-83 For auto-tracking operation with both positive and negative outputs, as shown in Figure 3-17, the equation in Paragraph 3-79 is used to determine the values of R_X

and R_Y for the slaves providing positive outputs, and the equation in Paragraph 3-68 is used to determine the value of R_X and R_Y for the slaves providing negative outputs.

3-84 To maintain the temperature coefficient and stability specifications of the supplies, R_X and R_Y must be stable, low-noise resistors with temperature coefficients of less than 25 ppm per °C and power ratings at least 30 times what they will actually dissipate

3-85 The front panel VOLTAGE control of the slave can be used in place of R_Y by connecting a strap from A2 of the slave to A1 of the slave. This enables the user to vary the ratio of the slave output voltage to the master output voltage. For calculation purposes, use a resistanc value of 2.7k for the VOLTAGE control when it is set to maximum.

3-86 Setting the Current Controls. The current controls of all supplies in an auto-tracking combination are independently operative and can be used to set current limits for each individual load. If the master supply goes into the constant current mode, the output voltages of the slaves continue to track that of the master. If a slave supply goes into constant current mode, however, no other supply is affected.

3-87 Overtoltage Protection in Auto-Tracking Set the OVP of each supply as appropriate for the load connected to that supply. If the master supply OVP trips, the master will program the slaves to zero output. If a slave OVP trips, only that slave and its load will be affected.

3-88 Auto-Tracking with Remote Sensing. To combine auto-tracking operation with remote sensing, connect the supplies as described above but remove the +S and -S jumpers from each supply and connect the +S and -S terminals directly to the + and - ends of its load.

3-89 Auto-Tracking with Remote Programming. The output voltages of an auto-tracking combination can be remotely programmed by programming connecti made to the master supply. In addition, the ratio of each slave's output to the master's output can be remotely programmed by connecting a variable resistor to the slave in place of R_Y . The output currents of the individual supplies can also be remotely programme Observe all precautions outlined in the remote programming paragraphs. Simultaneous use of remote sensing and remote programming is also possible during auto-tracking operation.

3-90 I-MONITOR OUTPUT SIGNAL

3-91 . An amplified and buffered output signal from the current-monitoring resistance (R_M) is available between terminals A4 and A5 on the rear panel. This signal can be connected to a remote voltmeter to

indicate the amount of output current. The signal varies from 0 to 5 volts to indicate a zero to full scale (10A) current output. The — terminal of the voltmeter should be connected to terminal A5. Output impedance at terminal A4 is 10k; a load of 1 megohm will maintain 1% reading accuracy.

