

# HP 41952A/B

## TRANSMISSION/REFLECTION

### TEST SET

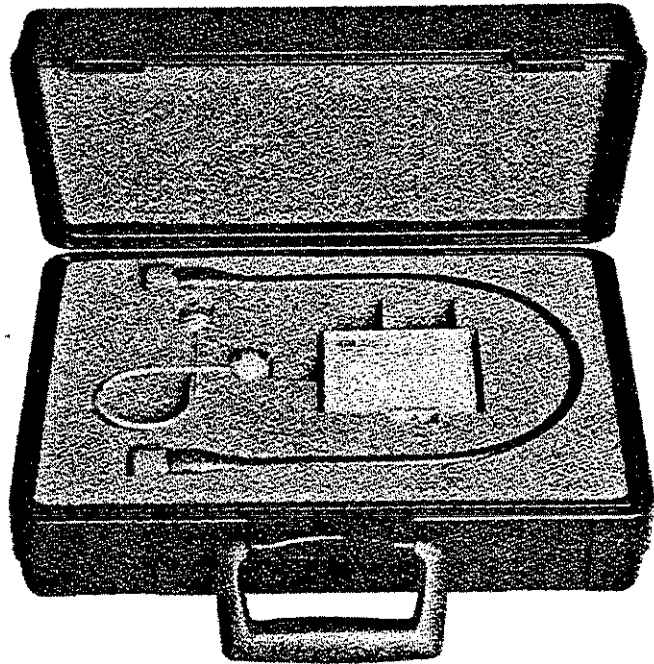

DEC. 1986



HEWLETT  
PACKARD

## **WARRANTY AND ASSISTANCE**

All Hewlett-Packard products are warranted against defects in materials and workmanship. This warranty applies for one year from the date of delivery, or, in the case of certain major components listed in the operating manual, for the specified period. We will repair or replace products which prove to be defective during the warranty period provided they are returned to Hewlett-Packard. No other warranty is expressed or implied. We are not liable for consequential damages.

For any assistance, contact your nearest Hewlett-Packard Sales and Service Office. Addresses are provided at the back of this manual.



**HEWLETT  
PACKARD**

## **OPERATION NOTE**

**MODEL 41952A/B**

**TRANSMISSION/REFLECTION**

**TEST SET**

### **SERIAL NUMBERS**

This manual applies directly to HP 41952A or HP 41952B Transmission/Reflection Test Set with serial number prefixed 2850J.

© COPYRIGHT: YOKOGAWA-HEWLETT-PACKARD, LTD., 1988  
9-1, TAKAKURA-CHO, HACHIOJI-SHI, TOKYO, JAPAN

Manual Part Number: 41952-90000  
Microfiche Part Number: 41952-90050

Printed: December 1988

# TABLE OF CONTENTS

---

## SECTION 1:

### GENERAL INFORMATION

INTRODUCTION	1-1
PRODUCT DESCRIPTION	1-1
SAFETY CONSIDERATIONS	1-2
UNITS COVERED BY THIS OPERATION NOTE	1-2
PRODUCT CONTENTS	1-3
SPECIFICATIONS	1-3
ACCESSORIES AVAILABLE	1-6

---

## SECTION 2:

### INSTALLATION

SECTION CONTENTS	2-1
INITIAL INSPECTION	2-1
ENVIRONMENTAL REQUIREMENTS	2-3
PACKAGING	2-3
Original Packaging	2-3
Other Packaging	2-3

---

## SECTION 3:

### OPERATION

SECTION CONTENTS	3-1
OVERVIEW	3-1
OPERATOR'S CHECK	3-4
TYPICAL MEASUREMENT SETUPS	3-6
Transmission/Reflection Measurements	3-7
S-Parameter Measurements	3-9
CALIBRATION CONSIDERATIONS	3-11

---

## SECTION 4:

### PERFORMANCE TESTS

INTRODUCTION	4-1
EQUIPMENT REQUIRED	4-1
CALIBRATION CYCLE	4-2
PREPARATION	4-2
DIRECTIVITY TEST	4-5
EFFECTIVE SOURCE MATCH TEST	4-9
PORT MATCH TEST	4-13

---

## SECTION 5:

### SERVICE

INTRODUCTION	5-1
REPLACEABLE PARTS	5-1

**GENERAL INFORMATION**

---

**INTRODUCTION**

This section provides the specification and the information necessary for receiving, performing an incoming inspection, preparing the HP 41952A/B for use.

---

**PRODUCT DESCRIPTION**

The HP 41952A and HP 41952B Transmission/Reflection Test Sets are used with the HP 4195A to perform both transmission and reflection measurements. The HP 41952A is used for 50 $\Omega$  applications and the HP 41952B is used for 75 $\Omega$  applications. Using two HP 41952A or HP 41952B test sets, full S-parameter measurements can be performed. The following are the main feature of the HP 41952A/B.

- Frequency range : 100 kHz to 500 MHz
- Directivity : 40 dB (HP 41952A, 300 kHz to 200 MHz)
- Effective Source Match :  $\geq 20$  dB ( $\geq 300$  kHz)
- Direct connection to the HP 4195A

---

**SAFETY  
CONSIDERATIONS**

The HP 41952A/B Transmission/Reflection Test Sets conform to the safety requirements for IEC 348, and CSA 556B instruments, and is shipped from the factory in a safe condition. This operation note contains information, **CAUTIONS** and **WARNINGS** which must be followed by the user to ensure safe operation.

---

**UNITS COVERED BY  
THIS OPERATION  
NOTE**

Hewlett-Packard uses a two-part, nine character serial number which is stamped on the serial number plate (see Figure 1-1) attached to the inside of the carrying case. The first four digits and a letter are the prefix and the last five digits are the suffix of the serial number. The letter in the serial number identifies the country where the instrument was manufactured. The prefix is same for all identical instruments, it changes only when a change is made to the instrument. The suffix, however, is assigned sequentially and is different for each instrument. This operation note applies to instruments with serial number prefixes listed under **Serial Numbers** on the title page.



Figure 1-1. Serial Number Plate

Units manufactured after this operation note was printed may have a serial number prefix which is not listed on the title page. An unlisted serial number prefix indicates that the instrument may be different from those described in this operation note. Operation notes for new instruments may be accompanied by a yellow Manual Supplement page, or have a different part number. This supplement contains "Change Information" explaining how to adapt this operation note to newer instruments.

In addition to change information, the supplement may contain information for correcting errors (Errata) in previous operation notes. To keep this operation note as current and accurate as possible, Hewlett-Packard recommends that you periodically request the latest Manual Change supplements. The supplement for this operation note is identified by the **Print Date** and **Part Number**, both of which appear on the operation note's title page.

For information concerning the serial number prefixes not listed on the title page or in the Manual Change supplements, contact your nearest Hewlett-Packard sales office.

---

## PRODUCT CONTENTS

Table 1-1 shows the contents of the HP 41952A/B. Refer to Figure 2-1 for details.

Table 1-1. Contents of the HP 41952A/B

Description	Qty.
Test Set, 50Ω (HP 1952A only)	1
Test Set, 75Ω (HP 41952B only)	1
N(m)-N(m) Cable, 50Ω (HP 41952A and HP 41952B standard only <sup>1</sup> )	1
Semi-rigid Cable, type N, 50Ω	1
HP 11852B Minimum Loss Pad, 50Ω-75Ω (HP 41952B standard only <sup>1</sup> )	1
Carrying Case	1

<sup>1</sup> 50Ω N(m) cable and HP 11852B Minimum Loss Pad are deleted for the HP 41952B with Option 009.

---

## SPECIFICATIONS

The specifications for the HP 41952A and HP 41952B Transmission/Reflection Test Sets are listed in Table 1-2. The specifications are performance standards or limits. The HP 41952A/B meets all of the specifications listed in Table 1-2 when it is shipped from the factory.

Table 1-2. Specifications (1 of 2)

Specifications describe the instrument's warranted performance over the temperature range of  $23 \pm 5^\circ\text{C}$  (except where noted). Supplemental characteristics are intended to provide information useful in applying the instrument by giving non-warranted performance parameters. These are denoted as "typical", "nominal", or "approximate".

	HP 41952A	HP 41952B
<b>Impedance:</b>	50 $\Omega$	75 $\Omega$
<b>Frequency Range:</b>	100 kHz to 500 MHz	100 kHz to 500 MHz
<b>Directivity:</b>		
<300 kHz	30 dB	30 dB
300 kHz to 200 MHz	40 dB	35 dB
>200 MHz	35 dB	35 dB
<b>Typical Frequency Response: <sup>1</sup></b>		
Transmission (Magnitude <sup>2</sup> , Phase <sup>3</sup> ):	$\pm 1$ dB, $\pm 5$ deg	$\pm 1$ dB, $\pm 5$ deg
Reflection (Magnitude <sup>2</sup> , Phase <sup>3</sup> ):		
<300 kHz	$\pm 1$ dB, $\pm 15$ deg	$\pm 1$ dB, $\pm 20$ deg
300 kHz to 1 MHz	$\pm 1$ dB, $\pm 5$ deg	$\pm 1$ dB, $\pm 10$ deg
>1 MHz	$\pm 1$ dB, $\pm 5$ deg	$\pm 1$ dB, $\pm 5$ deg
<sup>1</sup> can be removed with the HP 4195A's NORMALIZATION function <sup>2</sup> deviation from mean value <sup>3</sup> deviation from linear phase		
<b>Effective Source Match (TEST PORT):</b>		
<300 kHz	$\geq 15$ dB	$\geq 15$ dB
$\geq 300$ kHz	$\geq 20$ dB	$\geq 20$ dB
<b>Port Match (INCIDENT, REFLECTED and RF INPUT):</b>		
	$\geq 20$ dB	$\geq 20$ dB
<b>Insertion Loss (Nominal):</b>		
RF INPUT to TEST PORT:	13 dB	19 dB
RF INPUT to INCIDENT:	19 dB	31 dB
RF INPUT to REFLECTED:	19 dB	31 dB
<b>Maximum Input Level:</b>		
RF INPUT:	+20 dBm	+20 dBm
TEST PORT:	+20 dBm	+20 dBm



Table 1-2. Specifications (2 of 2)

	HP 41952A	HP 41952B
<b>Damage Level:</b>		
RF INPUT:	+23 dBm	+23 dBm
TEST PORT:	+23 dBm	+23 dBm
<b>Connector:</b>		
TEST PORT:	50 $\Omega$ Type N(f)	75 $\Omega$ Type N(f)
RF INPUT:	50 $\Omega$ Type N(f)	50 $\Omega$ Type N(f)
INCIDENT and REFLECTED:	50 $\Omega$ Type N(m)	50 $\Omega$ Type N(m)
<b>Operating Conditions:</b>		
Temperature:	0 °C to 55 °C	0 °C to 55 °C
Relative Humidity:	<95 % at 40 °C	<95 % at 40 °C
<b>Option:</b>	_____	Option 009* : Delete 50 $\Omega$ N cable and HP 11852B
* For 75 $\Omega$ S-parameter measurements with the HP 4195A and two set of the HP 41952B.		

---

**ACCESSORIES  
AVAILABLE**

The accessories listed in Table 1-3 are available, for making certain types of measurements and for convenience in connecting the device under test.

Table 1-3. Available Accessories

Description	HP Part Number
Cable Kit, 50 $\Omega$ , Type N	HP 11851B
Cable Kit, 75 $\Omega$ , Type N	HP 1857B
Calibration Kit, 50 $\Omega$ , Type N	HP 5032B
Calibration Kit, 75 $\Omega$ , Type N	HP 5036B
Accessory Kit, 50 $\Omega$ , Type N	HP 1853A
Accessory Kit, 50 $\Omega$ , Type BNC	HP 1854A
Accessory Kit, 75 $\Omega$ , Type N	HP 1855A
Accessory Kit, 75 $\Omega$ , Type BNC	HP 1856A

# INSTALLATION

---

### SECTION CONTENTS

This section provides the following information.

- Initial Inspection
- Mating Connectors
- Environmental Requirements
- Packaging

---

### INITIAL INSPECTION

The HP 41952A/B Transmission/Refraction Test Sets meet all of the specifications listed in Table 1-3. Upon receipt, inspect the shipping container for damage. If the shipping container or the cushioning material has been damaged, keep the container and packing material until the contents have been checked for completeness and the test set has been checked out mechanically and electrically. Figure 2-1 shows the product overview. The procedures for checking the general electrical operation are given in **SECTION 4, PERFORMANCE TEST**.

If anything is missing, damaged (scratches, dents, broken connectors, etc.), or if performance does not meet the performance test limits, notify the nearest HP sales office (see the list at the back of this operation note). The HP sales office will immediately arrange for repair or replacement without waiting for a claim settlement.

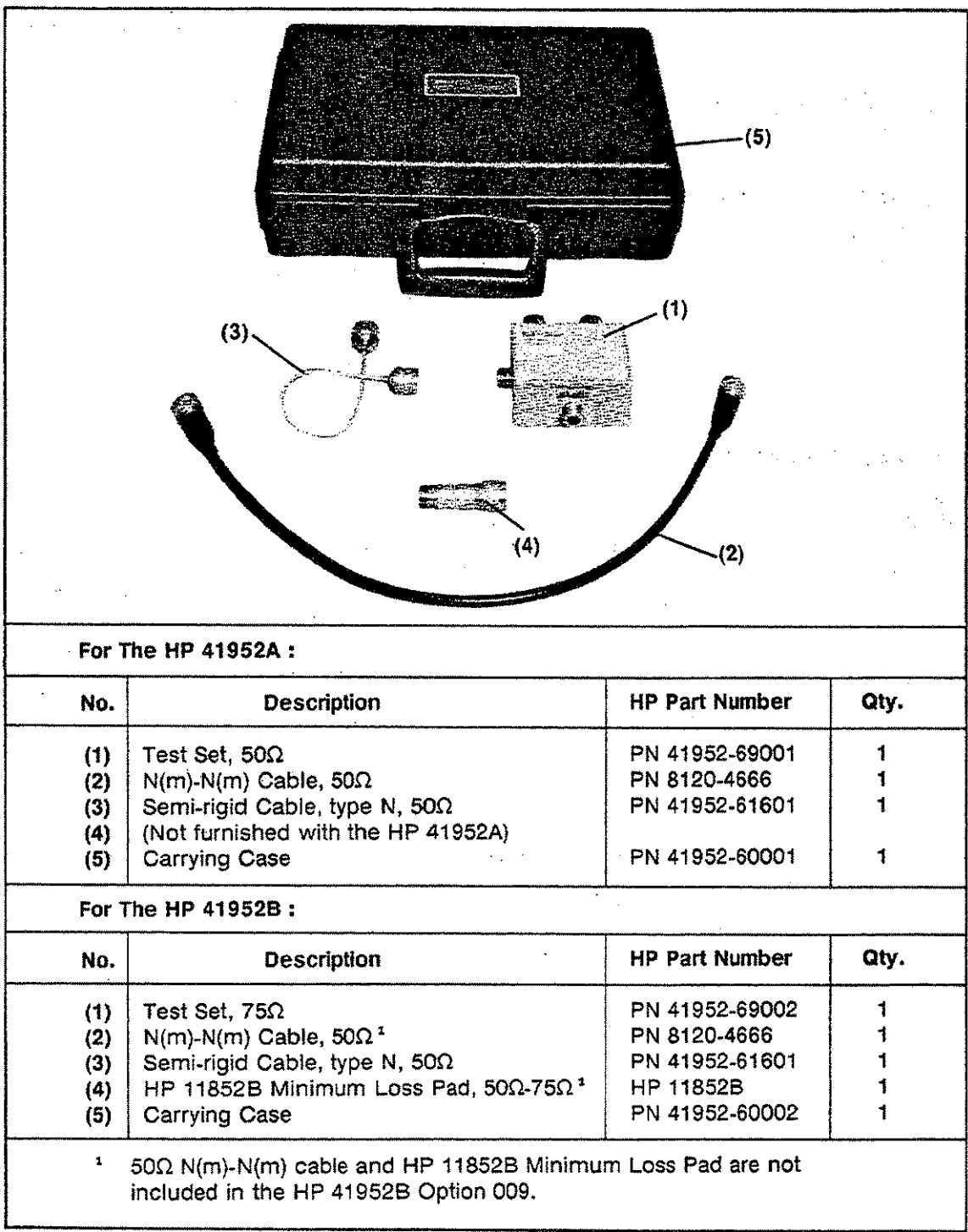

Figure 2-1. Product Overview

---

## **ENVIRONMENTAL REQUIREMENTS**

The HP 41952A/B may be stored or shipped under the following environmental condition.

- Temperature : -40°C to +70°C

The unit must be protected from temperature extremes which can cause condensation.

---

## **PACKAGING**

This paragraph describes how to repackage the HP 41952A/B for shipment when necessary.

### **Original Packaging**

Containers and packing material identical to those used in factory packaging are available from Hewlett-Packard. If the unit is being returned to Hewlett-Packard for servicing, attach a tag indicating the type of service required, return address, model number and full serial number.

### **Other Packaging**

The following general instructions should be used for repacking with commercially available materials.

1. Wrap the unit in heavy paper or plastic. If shipping to a HP sales office or service center, attach a tag indicating the type of service required, return address, model number and full serial number.
2. Use a strong shipping container. A double-walled carton made of 350 pound test material is adequate.
3. Use enough shock absorbing material (a 3 to 4 inch layer) around all sides of the unit to provide a firm cushion and to prevent the unit from moving inside the container.
4. Seal the shipping container securely.
5. Mark the shipping container **FRAGILE** to ensure careful handling.
6. In any correspondence, refer to unit by its model number and the full serial number.

# NOTES

OPERATION

SECTION CONTENTS

This section provides the following information.

- Overview
- Operator's Check
- Typical Measurement Setups
- Calibration Considerations

OVERVIEW

Figure 3-1 shows the main features of the HP 41952A/B test sets and their simple block diagrams, and the following description is corresponded to each features.

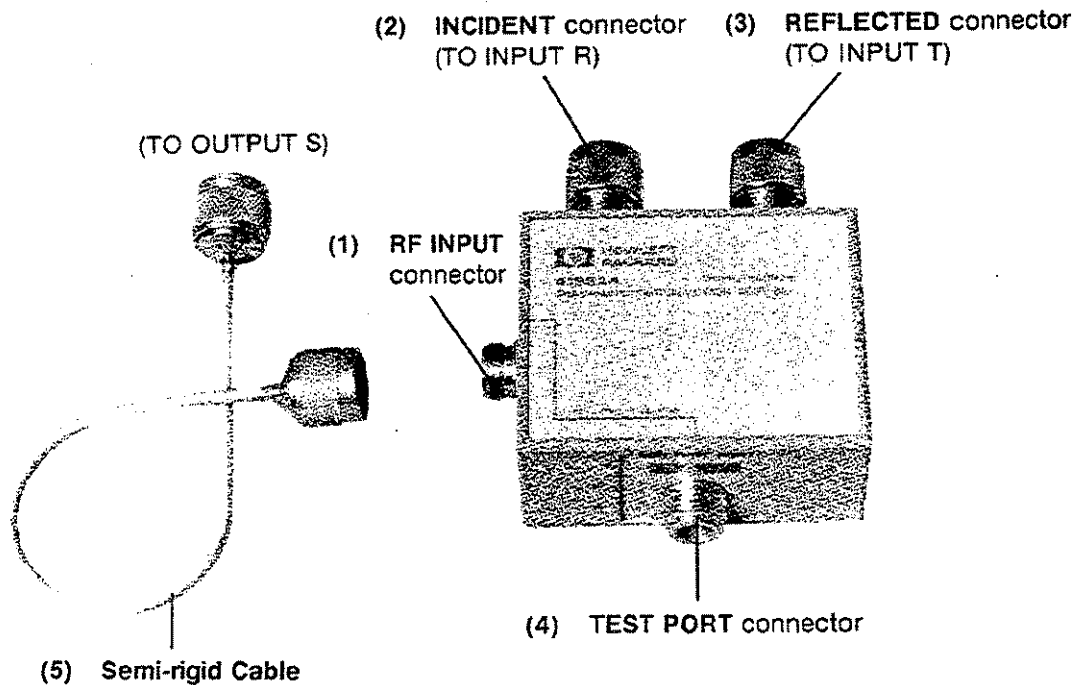
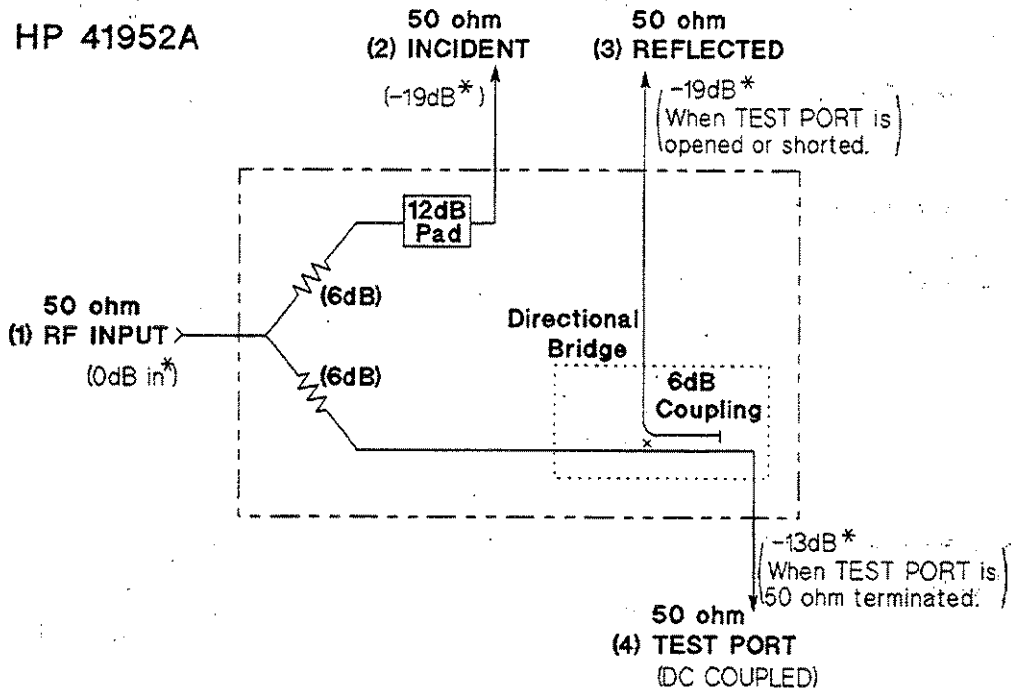
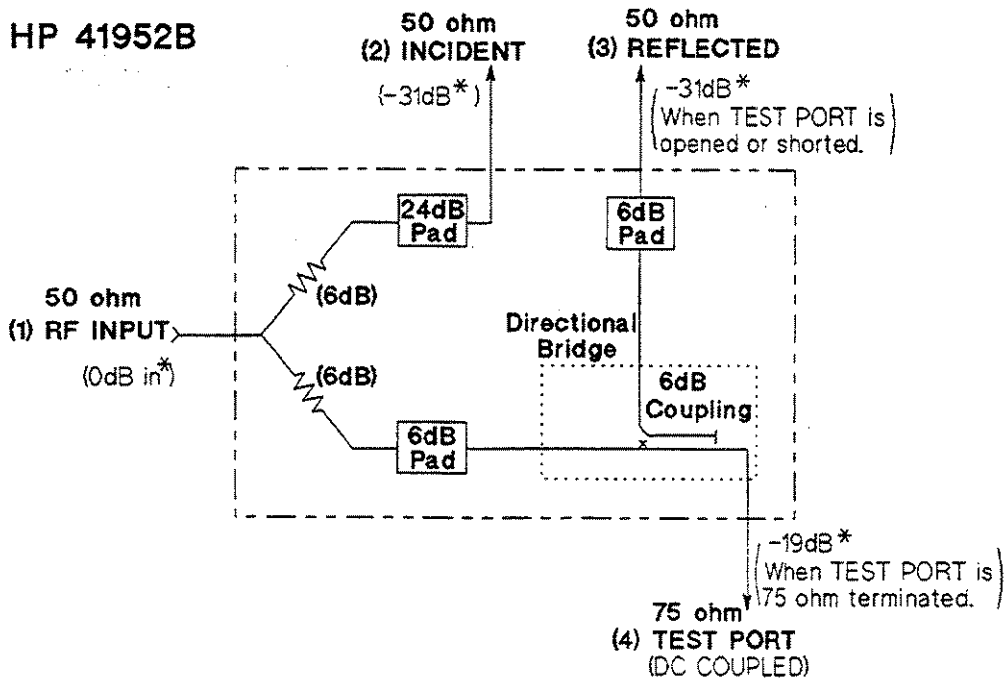

Figure 3-1. HP 41952A/B Test Sets Features (1/2)

**HP 41952A**



**HP 41952B**



\* Levels applied to each connector when a 0dB level is applied to the RF INPUT connector.

Figure 3-1. HP 41952A/B Test Sets Features (2/2)



- (1) **RF INPUT** connector : 50 $\Omega$  N(f) connector  
The output signal from HP 4195A's **OUTPUT S1** or **S2** is input through the **RF INPUT** connector, the signal is then split and fed to the **INCIDENT** and **TEST PORT / REFLECTED** connectors.
- (2) **INCIDENT** connector : 50 $\Omega$  N(m) connector  
This connector is used to route a portion (**INCIDENT**) of the **OUTPUT S1** or **S2** signal to the HP 4195A's **INPUT R1** or **R2**. This signal is used as the reference signal for ratio measurements.
- (3) **REFLECTED** connector : 50 $\Omega$  N(m) connector  
This connector is used to route the **REFLECTED** signal from the **DUT** to the HP 4195A's **INPUT T1** or **T2**.
- (4) **TEST PORT** connector :HP 41952A :50 $\Omega$  N(f) connector  
:HP 41952B :75 $\Omega$  N(f) connector  
This connector is used to route the **OUTPUT** signal to the **DUT** and to receive the **REFLECTED** signal from the **DUT**.
- (5) Semi-rigid cable : 50 $\Omega$  N(m)-N(m) cable  
This cable is used to connect HP 4195A **OUTPUT S1** or **S2** to the HP 41952A/B's **RF INPUT**.

**CAUTION**

Do not apply signals with power levels exceeding +23 dBm to the **RF INPUT** and **TEST PORT** connectors or damage may result.

**CAUTION**

Do not mate a 50 $\Omega$  type-N connector to a 75 $\Omega$  type-N connector or damage may result.

## OPERATOR'S CHECK

This paragraph describes the HP 41952A/B operator's check. This check procedure is intended only to ensure that the HP 41952A/B is functional. If the HP 41952A/B fails this check, it must be repaired. To verify that the HP 41952A/B meets the specifications, run the **PERFORMANCE TEST** described in **SECTION 4**.

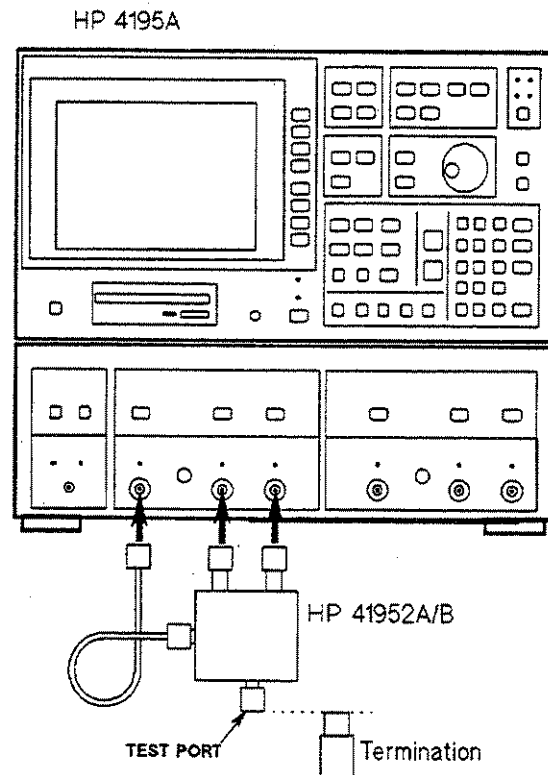

Figure 3-2. Operator's Check Setup

### [Equipment]

- Network Analyzer HP 4195A
- 50 $\Omega$  Termination  
(for HP 41952A only) HP PN 85032-60004  
or HP 909C/F opt.012
- 75 $\Omega$  Termination  
(for HP 41952B only) HP PN 85036-60008

### [Procedure]

1. Connect the HP 41952A/B to the network analyzer as shown in Figure 3-2. Do not connect the termination to the **TEST PORT** connector of the HP 41952A/B.

2. Set the network analyzer's start frequency to **10 MHz** and its stop frequency to **500 MHz**.
3. Set the network analyzer's output level to **0 dBm**.
4. The network analyzer's magnitude ratio reading should be approximately **0 dB**.
5. Connect a termination (**50  $\Omega$**  termination for the HP 41952A or **75  $\Omega$**  termination for the HP 41952B) to the HP 41952A/B's **TEST PORT** connector.
6. The network analyzer's magnitude ratio reading should be less than **-30 dB**.

---

## TYPICAL MEASUREMENT SETUPS

This paragraph provides typical measurement setups using the HP 41952A/B. The following setups are described.

- Transmission/Reflection Measurement
  - Using HP 41952A (50  $\Omega$ )
  - Using HP 41952B (75  $\Omega$ )
- S-parameter Measurement
  - Using HP 41952A (50  $\Omega$ )
  - Using HP 41952B (75  $\Omega$ )

### CAUTION

Do not mate a 50 $\Omega$  type-N connector to a 75 $\Omega$  type-N connector or damage may result.

### CAUTION

Do not apply signals with power levels exceeding +23 dBm to the RF INPUT and TEST PORT connectors or damage may result.

**Transmission/  
Reflection  
Measurements**

**[Using the HP 41952A (50Ω)]**

Figure 3-3 shows typical measurement setup for a Transmission/  
Reflection measurement of a 50Ω system.

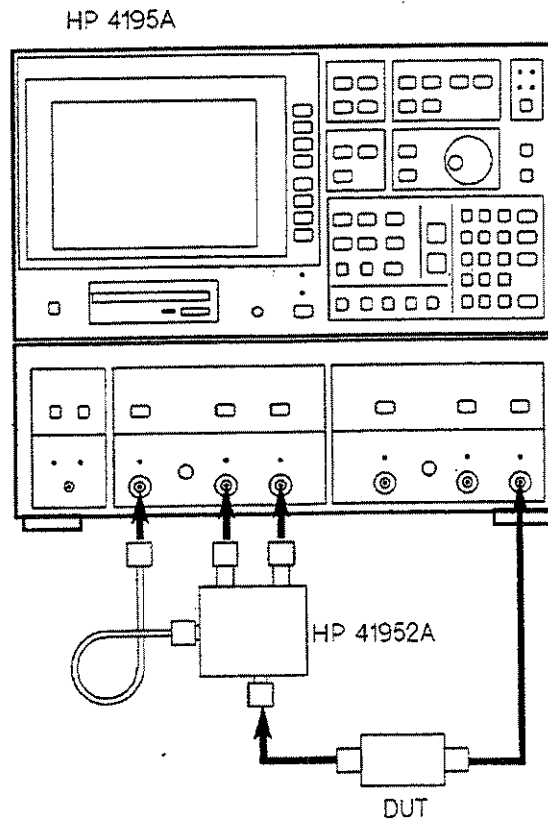

**Figure 3-3. Transmission/Reflection Measurement Setup Example  
Using the HP 41952A (50Ω)**

[Using HP 41952B (75Ω)]

Figure 3-4 shows typical measurement setup for the Transmission/Reflection measurement of a 75Ω system. Set the characteristic impedance setting of the HP 4195A to 75Ω using the 'Z0 50Ω 75Ω' softkey.

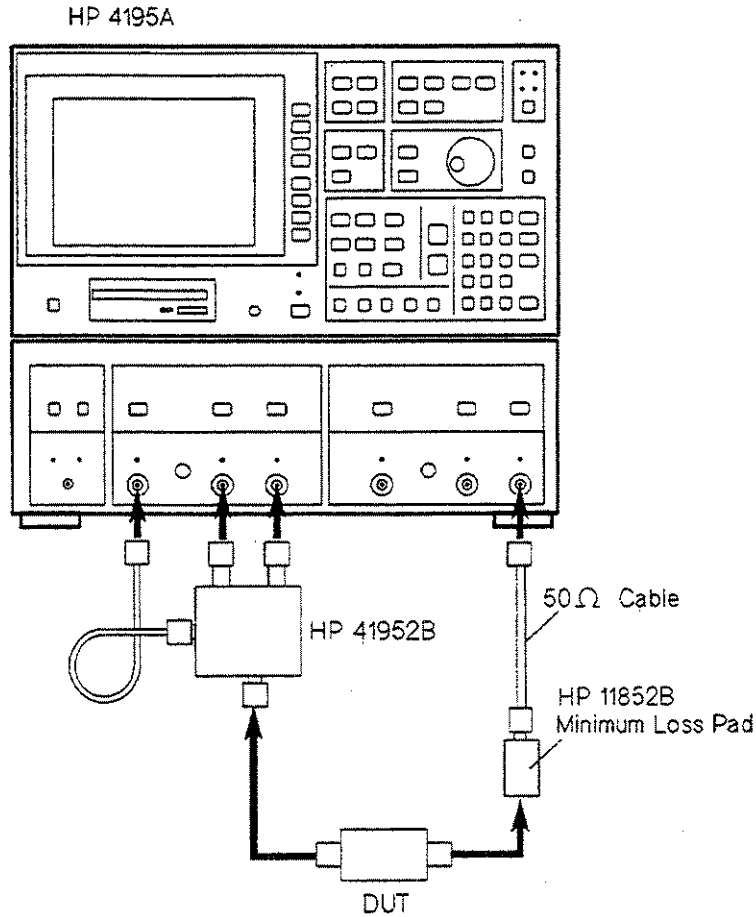

Figure 3-4. Transmission/Reflection Measurement Setup Example Using the HP 41952B (75Ω)

**S-Parameter  
Measurements**

[Using the HP 41952A (50Ω)]

Figure 3-5 shows a typical measurement setup for making S-parameter measurements of a 50Ω system.

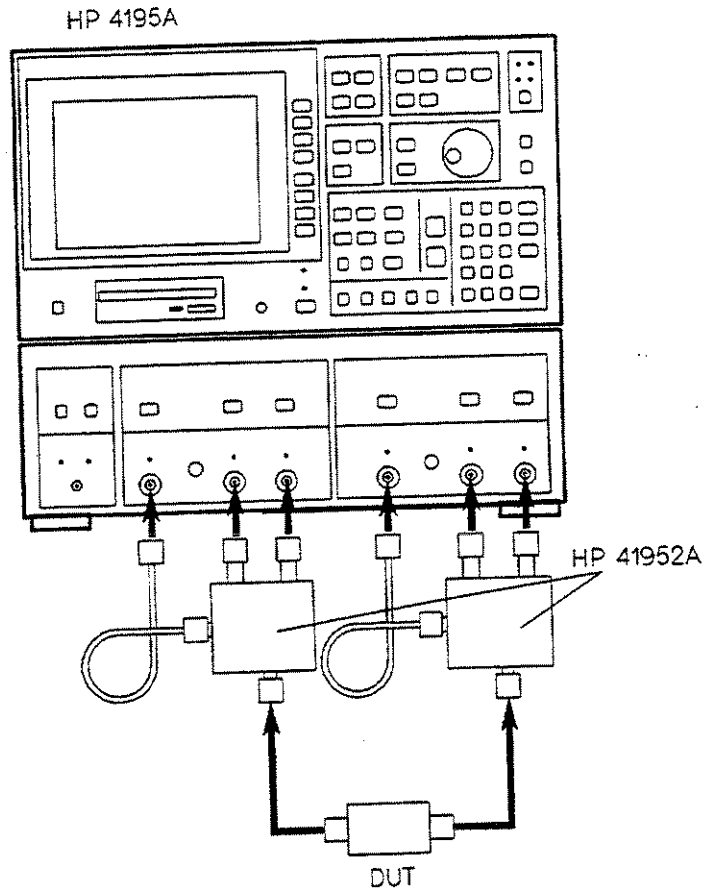

Figure 3-5. S-Parameter Measurement Setup Example  
Using the HP 41952A (50Ω)

[Using HP 41952B (75Ω)]

Figure 3-6 shows a typical measurement setup for making a S-parameter measurement of a 75Ω system. Set the characteristic impedance setting of the HP 4195A to 75Ω using the 'Z0 50Ω 75Ω' softkey.

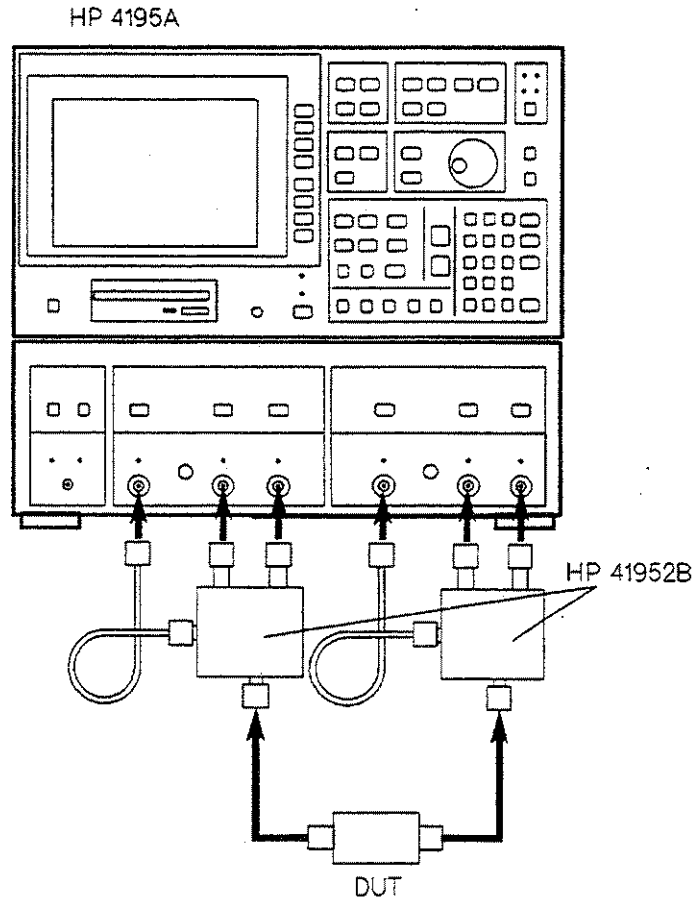

Figure 3-6. S-Parameter Measurement Setup Example  
Using the HP 41952B (75Ω)



## CALIBRATION CONSIDERATIONS

The HP 4195A provides calibration capabilities for enhancing measurement accuracy. You can select from the following calibration functions (appropriate for your measurement) to compensate for errors due to the test set. Refer to the HP 4195A Operation Manual for details.

- For Transmission Measurements
  - Normalize (Through) Calibration:  
Compensates frequency response errors.
  - Normalize & Isolation Calibration:  
Compensates frequency response and crosstalk errors.
- For Reflection Measurements
  - Normalize (Open) Calibration:  
Compensates frequency response errors.
  - One Port Partial Calibration:  
Compensates frequency response and directivity errors.
  - One Port Full Calibration:  
Compensates frequency response, directivity, and source mismatching errors.

### Calibration Standard Values

The standard values for reflection calibration are stored in the HP 4195A's memory, and these values can be modified to match your standards. Use the values listed in Table 3-1 for the standard values when using the HP 85032B or HP 85036B calibration kit.

Table 3-1. Standard Values

	OPEN		SHORT		LOAD	
HP 85032B N(m) connector	0 [S],	413E-15 [F]	0 [ $\Omega$ ],	878E-12 [H]	50 [ $\Omega$ ],	0 [H]
HP 85032B N(f) connector	0 [S],	108E-15 [F]	0 [ $\Omega$ ],	0 [H]	50 [ $\Omega$ ],	0 [H]
HP 85036B N(m) connector	0 [S],	275E-15 [F]	0 [ $\Omega$ ],	1317E-12 [H]	75 [ $\Omega$ ],	0 [H]
HP 85036B N(f) connector	0 [S],	635E-14 [F]	0 [ $\Omega$ ],	0 [H]	75 [ $\Omega$ ],	0 [H]

## NOTES

## PERFORMANCE TESTS

**INTRODUCTION**

This section provides the performance test procedure to ensure that the HP 41952A/B meets the specifications listed in Table 1-3, Specifications. The performance test can be performed without accessing the interior of the HP 41952A/B.

The test results should be recorded into the Performance Test Record located at the end of this section.

**EQUIPMENT REQUIRED**

The equipment required for performance testing is listed in Table 4-1. Substitutions can be made for the equipment in this list if the specifications meet or exceed the specifications listed in the Requirements column.

Table 4-1. Recommended Test Equipment

Equipment Recommended Model	Qty.	Requirements
Network Analyzer HP 4195A	1	No substitute
T/R Test Set HP 41952A	1	No substitute
Calibration Kit HP 85032B	1	No substitute (use open/short/50 $\Omega$ termination)
Calibration Kit HP 85036B * <sup>1</sup>	1	No substitute (use open/short/75 $\Omega$ termination)
Termination HP 909C Opt.200, Opt.012 * <sup>2</sup>	1	Type N(m), 50 $\Omega$ Frequency: $\leq$ 200 MHz Return Loss: $\geq$ 52 dB
Termination HP 909F Opt.012 * <sup>2</sup>	1	Type N(m), 50 $\Omega$ Frequency: 100 kHz to 500 MHz Return Loss: $\geq$ 47 dB
Adapter	1 1	N(f)-N(f), 50 $\Omega$ N(m)-N(m), 50 $\Omega$

Note: \*<sup>1</sup> Used for performance testing the HP 41952B.  
\*<sup>2</sup> Used for performance testing the HP 41952A.

---

## CALIBRATION CYCLE

The HP 41952A/B requires periodic performance verification. The HP 41952A/B should be checked out using the performance test at least once a year or more depending on the frequency of use. Preventive maintenance should be performed at least twice a year to keep down-time to a minimum, and to insure optimum operation.

---

## PREPARATION

This paragraph provides the information you need to know, and the steps you must perform before starting the performance test.

1. The test equipment must be allowed to warm-up and stabilize for at least 30 minutes.
2. An HP 4195A is required to performance test the HP 41952A/B. In the remainder of this manual, the HP 4195A's softkeys are indicated in boldface type and are enclosed in single quotes (e.g., 'NETWORK' softkey), and keys are indicated in bold face type only (e.g., PRESET key).
3. The HP 4195A's calibration capability is used to performance test the HP 41952A/B. Perform the procedure given below to change the calibration standard data stored in the HP 4195A before running the performance test. If you are testing a HP 41952A, perform steps a and b. If you are testing a HP 41952B, perform steps a through d.
  - a. Turn the HP 4195A ON, and sequentially press the **PRESET** and **CAL** keys, and the 'more 1/2' and 'CAL STD modify' softkeys.
  - b. Sequentially press the following keys.

'OPEN CAL STD', 0, green shiftkey, , (comma)  
4, 1, 3, EEX, - (minus), 1, 5, ENTER/EXECUTE

'SHORT CAL STD', 0, green shiftkey, , (comma)  
8, 7, 8, EEX, - (minus), 1, 2, ENTER/EXECUTE

'LOAD CAL STD', 5, 0, green shiftkey, , (comma)  
0, ENTER/EXECUTE

c. Sequentially press the HP 4195A's **CAL** key, and the 'more 1/2', 'Z0 50Ω 75Ω' and the 'CAL STD modify' softkeys.

d. Sequentially press the following keys.

'OPEN CAL STD', 0, green shiftkey, , (comma)  
2, 7, 5, EEX, - (minus), 1, 5, ENTER/EXECUTE

'SHORT CAL STD', 0, green shiftkey, , (comma)  
1, 3, 1, 7, EEX, - (minus), 1, 2, ENTER/EXECUTE

'LOAD CAL STD', 7, 5, green shiftkey, , (comma)  
0, ENTER/EXECUTE

## NOTES

**DIRECTIVITY TEST**

**SPECIFICATIONS:** (at 23 °C ±5 °C)

**HP 41952A:**     ≥ 30 dB at < 300 kHz  
                           ≥ 40 dB at 300 kHz to 200 MHz  
                           ≥ 35 dB at > 200 MHz

**HP 41952B:**     ≥ 30 dB at < 300 kHz  
                           ≥ 35 dB at ≥ 300 kHz

**SETUP:**

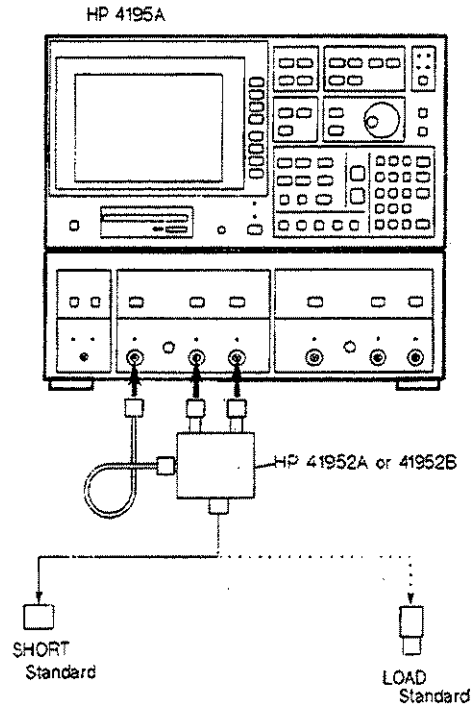

Figure 4-1. Directivity Test Setup

**EQUIPMENT:**

Network Analyzer	HP 4195A
Calibration Kit	HP 85032B* <sup>1</sup> HP 85036B* <sup>2</sup>
Termination	HP 909C Opt. 200 Opt. 012* <sup>1</sup>
Termination	HP 909F Opt. 012* <sup>1</sup>

Note: \*<sup>1</sup> Used for testing the HP 41952A  
       \*<sup>2</sup> Used for testing the HP 41952B

**PROCEDURE:**

1. Connect the HP 41952A/B to the HP 4195A, as shown in Figure 4-1.

## PERFORMANCE TESTS

---

2. Sequentially press the following HP 4195A front panel keys.

**CONFIG, 'NETWORK', PRESET**

**AMPLITUDE (CHANNEL 1 side), 1 , 0 , ENTER/EXECUTE**

**REF ATTEN (CHANNEL 1 side), 1 , 0 , ENTER/EXECUTE**

**TEST ATTEN (CHANNEL 1 side), 1 , 0 , ENTER/EXECUTE**

**START, 1 , 0 , 0 , kHz/dBm**

**RES BW, 1 , kHz/dBm**

**MENU, 'TRIGGER menu', 'SINGLE mode', 'return'**

**'TYPE lin log'** ("log" in the 'TYPE lin log' softkey will change to intensified green.)

**DISPLAY, 'TRACE B on off'** ("off" in the 'TRACE B on off' softkey will change to intensified green.)

### NOTE

If you are testing the HP 41952B, skip step 3.

3. Press the following keys, and skip step 4.

**STOP, 2 , 0 , 0 , MHz/V**

4. Press the following keys (only for testing the HP 41952B).

**STOP, 5 , 0 , 0 , MHz/V**

**CAL, 'more 1/2', 'Z0 50Ω 75Ω'**

("75Ω" in the 'Z0 50Ω 75Ω' softkey will change to intensified green.)

5. Connect the N(m) SHORT standard to the HP 41952A/B's TEST PORT connector.
6. Press the TRIG/RESET key on the HP 4195A's front panel, to make a single sweep measurement.
7. Enter the HP 4195A "C=A" command using the following keystrokes.

**CLR LINE, blue shiftkey, C , = , A , ENTER/EXECUTE**

8. Connect the N(m) LOAD standard (HP 909C Opt. 200, Opt. 012 for testing HP 41952A, HP 85036B's 75 Ω standard (85036-60008) for testing HP 41952B) to the HP 41952A/B's TEST PORT connector.

9. Press the HP 4195A's TRIG/RESET key.



## PERFORMANCE TESTS

---

10. Enter the HP 4195A "A=C-A" command using the following keystrokes to have the HP 4195A display the Directivity Test results.

**CLR LINE**, blue shiftkey, **A**, =, **C**, - (minus), **A**, **ENTER/EXECUTE**

11. Press the **SCALE REF** key and the '**A AUTO SCALE**' softkey for auto scaling.
12. Sequentially press the following keys to set the HP 4195A's analysis range between 100 kHz and 300 kHz.

**MORE**, '**ANA RNG**'

(move the \* marker to the point as close as possible to 300 kHz by rotating the HP 4195A's rotary knob.)

'**active oMKR \*MKR**' ("oMKR" in this softkey will change to intensified green.)

(move the o marker to the 100 kHz point)

'**STORE ANA RNG**'

'**PART ANA on off**' ("on" in this softkey will change to intensified green.)

13. Press the **MKR→** key and '**MKR→MIN**' softkey.
14. Confirm that the T/R data displayed on the upper right corner of the HP 4195A's display (Directivity Test result) is within the test limits listed in Table 4-2, Directivity Test Limit.
15. Sequentially press the following keys to set the HP 4195A's analysis range between 300 kHz, and the stop frequency point (200 MHz for testing a HP 41952A, or 500 MHz for testing a HP 41952B).

**MORE**, '**ANA RNG**'

(move o marker to the STOP frequency point)

'**STORE ANA RNG**'

16. Press the **MKR→** key and '**MKR→MIN**' softkey.
17. Confirm that the T/R data displayed on the upper right corner of the HP 4195A's display (Directivity Test result) is within the test limits listed in Table 4-2, Directivity Test Limits.

### NOTE

If you are testing a HP 41952B, do not perform step 18.

**PERFORMANCE TESTS**

---

18. Perform steps a through j only when testing a HP 41952A.
- a. Sequentially press the following HP 4195A keys.  
**START, 2, 0, 0, MHz/V**  
**STOP, 5, 0, 0, MHz/V**
  - b. Connect the HP 85032B's N(m) SHORT standard (HP 11512A) to the HP 41952A's TEST PORT connector.
  - c. Press the HP 4195A front panel TRIG/RESET key to perform a single sweep measurement.
  - d. Enter the HP 4195A "C=A" command using the following keystrokes.  
**CLR LINE, blue shiftkey, C, =, A, ENTER/EXECUTE**
  - e. Connect a the 50  $\Omega$  Termination (HP 909F Opt. 012) to the HP 41952A's TEST PORT connector.
  - f. Press the HP 4195A TRIG/RESET key.
  - g. Enter the HP 4195A "A=C-A" command using the following keystrokes to have the HP 4195A display the Directivity Test results.  
**CLR LINE, blue shiftkey, A, =, C, -, (minus), A, ENTER/EXECUTE**
  - h. Press the **SCALE REF** key and '**A AUTO SCALE**' softkey for auto scaling.
  - i. Sequentially press the **MKR→** key and the '**MKR→MIN**' softkey.
  - j. Confirm that the T/R data displayed in the upper right corner of the HP 4195A's display (Directivity Test result) is within the test limits listed in Table 4-2, Directivity Test Limits.

Table 4-2. Directivity Test Limits

**HP 41952A:**

Frequency	Test Limit
< 300 kHz	≥ 30 dB
300 kHz to 200 MHz	≥ 40 dB
> 200 MHz	≥ 35 dB

**HP 41952B:**

Frequency	Test Limit
< 300 kHz	≥ 30 dB
≥ 300 kHz	≥ 35 dB

**EFFECTIVE SOURCE MATCH TEST**

**SPECIFICATIONS:** (at 23 °C ±5 °C)

**TEST PORT:**     ≥ 15 dB at < 300 kHz  
                      ≥ 20 dB at ≥ 300 kHz

**SETUP:**

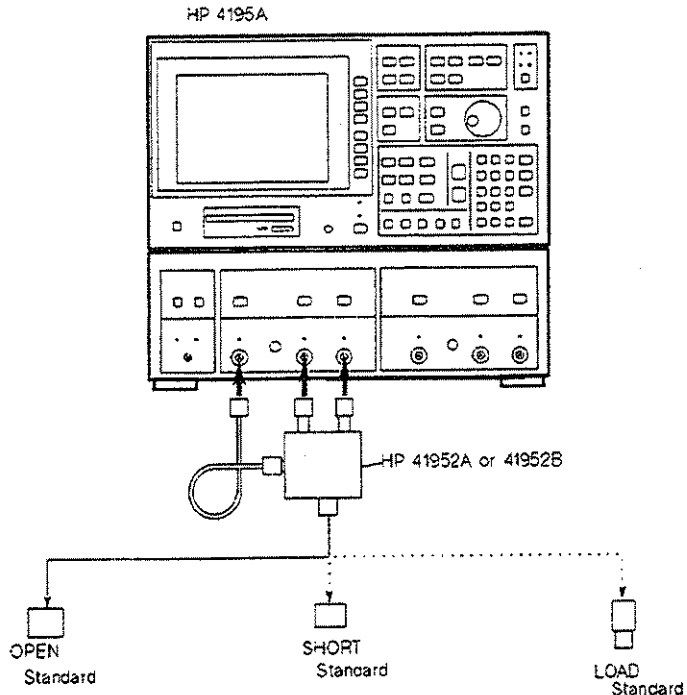

Figure 4-2. Effective Source Match Test Setup

**EQUIPMENT:**

Network Analyzer	HP 4195A
Calibration Kit	HP 85032B* <sup>1</sup>
	HP 85036B* <sup>2</sup>

Note: \*<sup>1</sup> Used for testing the HP 41952A  
      \*<sup>2</sup> Used for testing the HP 41952B

**PROCEDURE:**

1. Connect the HP 41952A/B to the HP 4195A, as shown in Figure 4-2.

## PERFORMANCE TESTS

---

2. Sequentially press the following HP 4195A front panel keys.

**CONFIG, 'S-PRMTR', 'S11', PRESET**

**AMPLITUDE (CHANNEL 1 side), 1 , 0 , ENTER/EXECUTE**

**REF ATTEN (CHANNEL 1 side), 1 , 0 , ENTER/EXECUTE**

**TEST ATTEN (CHANNEL 1 side), 1 , 0 , ENTER/EXECUTE**

**START, 1 , 0 , 0 , kHz/dBm**

**STOP, 5 , 0 , 0 , MHz/V**

**RES BW, 1 , kHz/dBm**

**MENU, 'TRIGGER menu', 'SINGLE mode', 'return'**

**'TYPE lin log'**

("log" in the 'TYPE lin log' softkey will change to intensified green.)

**DISPLAY, 'TRACE B on off'**

("off" in the 'TRACE B on off' softkey will change to intensified green.)

### NOTE

If you are testing a HP 41952A, skip step 3.

3. Press the following keys (only when testing a HP 41952B).

**CAL, 'more 1/2', 'Z0 50Ω 75Ω'**

(the "75Ω" in the 'Z0 50Ω 75Ω' softkey will change to intensified green.)

4. Sequentially press the HP 4195A's **CAL** key, and the '**S-PRMTR CAL menu**' and '**ONE PORT FULL CAL**' softkeys.
5. Connect the N(m) OPEN standard to the HP 41952A/B's TEST PORT connector.
6. Press the '**OPEN**' softkey and the **ENTER/EXECUTE** key. Wait until the single sweep measurement is completed.
7. Connect the N(m) SHORT standard to the HP 41952A/B's TEST PORT connector.
8. Press the '**SHORT**' softkey and the **ENTER/EXECUTE** key. Wait until the single sweep measurement is completed.
9. Connect the N(m) LOAD standard to the HP 41952A/B's TEST PORT connector.
10. Press the '**LOAD**' softkey and the **ENTER/EXECUTE** key. Wait until the single sweep measurement is completed.

## PERFORMANCE TESTS

11. Press the 'CAL' key and the 'CORRECTN on off' softkey. "on" in this softkey will change to intensified green.
12. Press the PROGRAM key, the 'EDIT' softkey and the ENTER/EXECUTE key, in sequence. The HP 4195A's display will change to the user program editor display.
13. Enter the following HP 4195A program to have it display the Effective Source Match test results. If you need more information on how to enter a HP 4195A program, refer to the HP 4195A's Operation Manual, paragraph 6-4, USER PROGRAM (Auto Sequence Program:ASP).

```
10 <RA,RB> = <MFOR,MFOI> * <TFSR,TFSI>
20 <RA,RB> = <RA,RB> - <MFSR,MFSI> * <TFOR,TFOI>
30 <RA,RB> = <RA,RB> + <MFLR,MFLI> * (<TFOR,TFOI> - <TFSR,TFSI>)
40 <RC,RD> = <MFOR,MFOI> * <TFOR,TFOI> * <TFSR,TFSI>
50 <RC,RD> = <RC,RD> - <MFSR,MFSI> * <TFSR,TFSI> * <TFOR,TFOI>
60 <RE,RF> = <RA,RB> / <RC,RD>
70 A = - 20 * LOG ( SQR ( RE * RE + RF * RF ) )
80 END
```

Note: To display "<", press the green shiftkey and < key.  
To display ">", press the green shiftkey and > key.  
To display ",", press the green shiftkey and , (comma) key.  
To display "\*", press the MATH OPERATOR key and ' \* ' softkey.  
To display "+", press the MATH OPERATOR key and ' + ' softkey.  
To display "/", press the MATH OPERATOR key and ' / ' softkey.  
To display "(", press the MATH OPERATOR key and ' ( ' softkey.  
To display ")", press the MATH OPERATOR key and ' ) ' softkey.  
To display any alphabet key, let the LED indicator in the blue shiftkey light, and press any alphabet key.

14. Sequentially press the PROGRAM key and the 'QUIT editor' and 'RUN' softkeys. Wait until the 'STOP' softkey changes to intensified green.
15. Press the SCALE REF key and the 'A AUTO SCALE' softkey for auto scaling.

**PERFORMANCE TESTS**

---

16. Sequentially press the following keys to set the HP 4195A's analysis range between 100 kHz and 300 kHz.

**MORE, 'ANA RNG'**

(move the \* marker to a point as close as possible to 300 kHz by rotating the HP 4195A's rotary knob)

**'active oMKR .MKR'** ("oMKR" in this softkey will change to intensified green.)

(move the o marker to the 100 kHz point)

**'STORE ANA RNG'**

**'PART ANA on off'** ("on" in this softkey will change to intensified green.)

17. Press the **MKR→** key and the **'MKR→MIN'** softkey.
18. Confirm that the data RL displayed on the upper right corner of the HP 4195A's display (Effective Source Match Test result) is within the test limits listed in Table 4-3, Effective Source Match Test Limits.
19. Press the following keys in sequence, to set the HP 4195A's analysis range between 300 kHz and 500 MHz.

**MORE, 'ANA RNG'**

(move o marker to 500 MHz point)

**'STORE ANA RNG'**

20. Press the **MKR→** key and the **'MKR→MIN'** softkey.
21. Confirm that the data RL displayed on the upper right corner of the HP 4195A's display (Effective Source Match Test result) is within the test limits listed in Table 4-3, Effective Source Match Test Limits.

Table 4-3. Effective Source Match Test Limits

Frequency	Test Limit
< 300 kHz	≥ 15 dB
≥ 300 kHz	≥ 20 dB

**PORT MATCH TEST**

**SPECIFICATIONS:** (at 23 °C ±5 °C)

INCIDENT, REFLECTED, RF INPUT:  $\geq 20$  dB

**SETUP:**

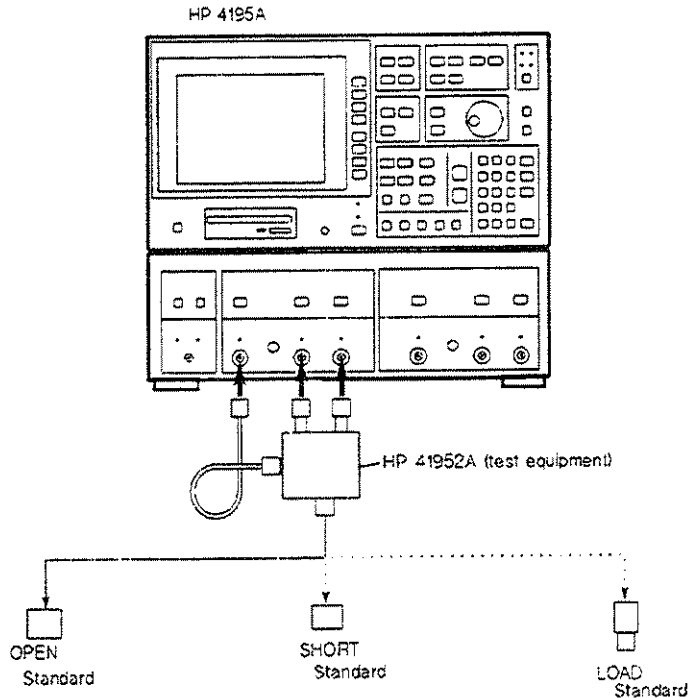

Figure 4-3. HP 41952A Calibration Setup

**EQUIPMENT:**

Network Analyzer	HP 4195A
T/R Test Set	HP 41952A* <sup>1</sup>
Calibration Kit	HP 85032B
	HP 85036B* <sup>2</sup>
50 Ω Termination	HP 909F Opt. 012* <sup>3</sup>
Adapters	as necessary

- Note: \*<sup>1</sup> Test equipment required to test the HP 41952A/B under test  
 \*<sup>2</sup> Used for testing the HP 41952B  
 \*<sup>3</sup> Used for testing the HP 41952A

**PROCEDURE:**

1. Connect the HP 41952A to the HP 4195A.

## PERFORMANCE TESTS

---

2. Turn the HP 4195A OFF and ON to initialize it, and then sequentially press the following HP 4195A front panel keys.

**CONFIG, 'S-PRMTR', 'S11', PRESET**

**AMPLITUDE (CHANNEL 1 side), 1 , 0 , ENTER/EXECUTE**

**REF ATTEN (CHANNEL 1 side), 1 , 0 , ENTER/EXECUTE**

**TEST ATTEN (CHANNEL 1 side), 1 , 0 , ENTER/EXECUTE**

**START, 1 , 0 , 0 , kHz/dBm**

**STOP, 5 , 0 , 0 , MHz/V**

**RES BW, 1 , kHz/dBm**

**MENU, 'TRIGGER menu', 'SINGLE mode'**

**DISPLAY, 'TRACE B on off'**

("off" in the 'TRACE B on off' softkey will change to intensified green.)

3. Perform the following procedure (steps a through h), to perform a 1 PORT FULL CALIBRATION for the TEST PORT connector of the HP 41952A (test equipment).
  - a. Sequentially press the HP 4195A's **CAL** key, and the '**S-PRMTR CAL menu**' and '**ONE PORT FULL CAL**' softkeys.
  - b. Connect the HP 85032B's N(m) OPEN standard to the TEST PORT connector of the HP 41952A (test equipment).
  - c. Press the '**OPEN**' softkey and the **ENTER/EXECUTE** key. Wait until the single sweep measurement is completed.
  - d. Connect the HP 85032B's N(m) SHORT standard to the TEST PORT connector of the HP 41952A (test equipment).
  - e. Press the '**SHORT**' softkey and **ENTER/EXECUTE** key. Wait until the single sweep measurement is completed.
  - f. Connect the HP 85032B's N(m) LOAD standard to the TEST PORT connector of the HP 41952A (test equipment).
  - g. Press the '**LOAD**' softkey and the **ENTER/EXECUTE** key. Wait until the single sweep measurement is completed.
  - h. Press the **CAL** key and the '**CORRECTN on off**' softkey. The "on" in this softkey will change to intensified green.



## PERFORMANCE TESTS

4. Perform the following procedure (steps a through i) to test the Port Match for the INCIDENT (R) connector of the HP 41952A/B (under test).

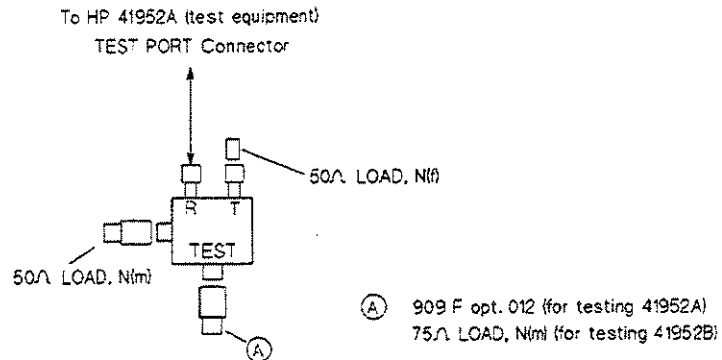

Figure 4-4. INCIDENT connector Port Match Test Setup

- a. Connect the N(m) LOAD standard (909F Opt. 012 for testing the HP 41952A, HP 85036B's 75 Ω standard for testing the HP 41952B) to the TEST PORT connector of the HP 41952A/B (under test).
  - b. Connect the HP 85032B's N(f) LOAD standard to the REFLECTED (T) connector of the HP 41952A/B (under test).
  - c. Connect the HP 85032B's N(m) LOAD standard to the RF INPUT connector of the HP 41952A/B (under test), as shown in Figure 4-4.
  - d. Connect the INCIDENT (R) connector of the HP 41952A/B (under test) to the TEST PORT connector of the HP 41952A (test equipment).
  - e. Press the HP 4195A's TRIG/RESET key, to make a single sweep measurement.
  - f. Enter the HP 4195A "A=-A" command using the following key stroke sequence to have the HP 4195A display the Port Match test results.  
**CLR LINE, blue shiftkey, A , = , - (minus), A , ENTER/EXECUTE**
  - g. Press the **SCALE REF** key and the 'A AUTO SCALE' softkey for auto scaling.
  - h. Press the **MKR→** key and the 'MKR→MIN' softkey to move the o marker to the minimum point.
  - i. Confirm that the RL data displayed on the upper right corner of the HP 4195A's display (Port Match test result) is greater than or equal to 20 dB.
5. Disconnect the HP 41952A/B (under test) from the HP 41952A (test equipment).
  6. Disconnect the HP 85032B's N(f) LOAD standard from the REFLECTED (T) connector of the HP 41952A/B (under test).

## PERFORMANCE TESTS

7. Perform the following procedure (steps a through g) to test the Port Match for the REFLECTED (T) connector of the HP 41952A/B (under test).

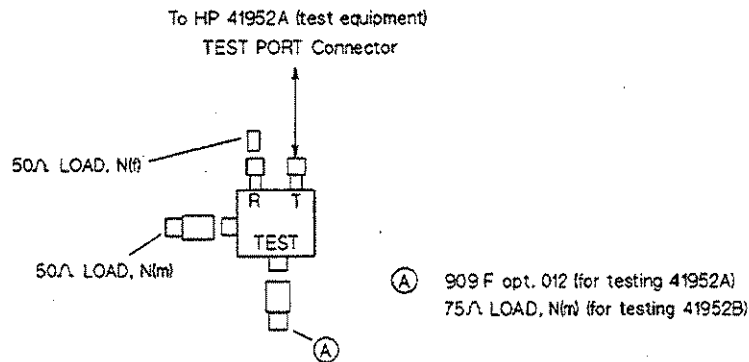

Figure 4-5. REFLECTED connector Port Match Test Setup

- a. Connect the HP 85032B's N(f) LOAD standard to the INCIDENT (R) connector of the HP 41952A/B (under test), as shown in Figure 4-5.
  - b. Connect the REFLECTED (T) connector of the HP 41952A/B (under test) to the TEST PORT connector of the HP 41952A (test equipment).
  - c. Press the HP 4195A's TRIG/RESET key to make a single sweep measurement.
  - d. Enter the HP 4195A "A=-A" command using the following key sequence to have the HP 4195A display the Port Match test result.  
**CLR LINE**, blue shiftkey, **A**, =, -, (minus), **A**, ENTER/EXECUTE
  - e. Press the **SCALE REF** key and the 'A AUTO SCALE' softkey for auto scaling.
  - f. Press the **MKR→** key and the 'MKR→MIN' softkey to move the o marker to the minimum point.
  - g. Confirm that the RL data displayed on the upper right corner of the HP 4195A's display (Port Match test result) is greater than or equal to 20 dB.
8. Disconnect the HP 41952A/B (under test) from the HP 41952A (test equipment).
  9. Disconnect the HP 85032B's N(m) LOAD standard and N(f) LOAD standard from the RF INPUT connector and the INCIDENT connector of the HP 41952A/B (under test), respectively.
  10. Connect the N(m)-N(m) Adapter to the TEST PORT connector of the HP 41952A (test equipment).

## PERFORMANCE TESTS

---

11. Use the following procedure (steps a through k), to perform a 1 PORT FULL CALIBRATION for the adapter on the TEST PORT connector of the HP 41952A (test equipment).
  - a. Sequentially press the HP 4195A's **CAL** key, and the '**CORRECTN on off**', '**more 1/2**', and '**CAL STD modify**' softkeys.
  - b. Sequentially press the following keys to change the HP 4195A's stored standard calibration data.  
  
**'OPEN CAL STD', 0 , green shiftkey, , (comma), 1 , 0 , 8  
EEX, - (minus), 1 , 5 , ENTER/EXECUTE**  
  
**'SHORT CAL STD', 0 , green shiftkey, , (comma), 0 , ENTER/EXECUTE**
  - c. Press the **MENU** key (once) and the '**TYPE lin log**' softkey (twice).
  - d. Sequentially press the HP 4195A's **CAL** key, and the '**S-PRMTR CAL menu**' and the '**ONE PORT FULL CAL**' softkeys.
  - e. Connect the HP 85032B's N(f) OPEN standard to the adapter on the TEST PORT connector of the HP 41952A (test equipment).
  - f. Press the '**OPEN**' softkey and the **ENTER/EXECUTE** key. Wait until the single sweep measurement is completed.
  - g. Connect the HP 85032B's N(f) SHORT standard to the adapter on the TEST PORT connector of the HP 41952A (test equipment).
  - h. Press the '**SHORT**' softkey and the **ENTER/EXECUTE** key. Wait until the single sweep measurement is completed.
  - i. Connect the HP 85032B's N(f) LOAD standard to the adapter on the TEST PORT connector of the HP 41952A (test equipment).
  - j. Press the '**LOAD**' softkey and the **ENTER/EXECUTE** key. Wait until the single sweep measurement is completed.
  - k. Press the **CAL** key and the '**CORRECTN on off**' softkey.
12. Perform the following procedure (steps a through h) to test the Port Match for the RF INPUT connector of the HP 41952A/B (under test).

## PERFORMANCE TESTS

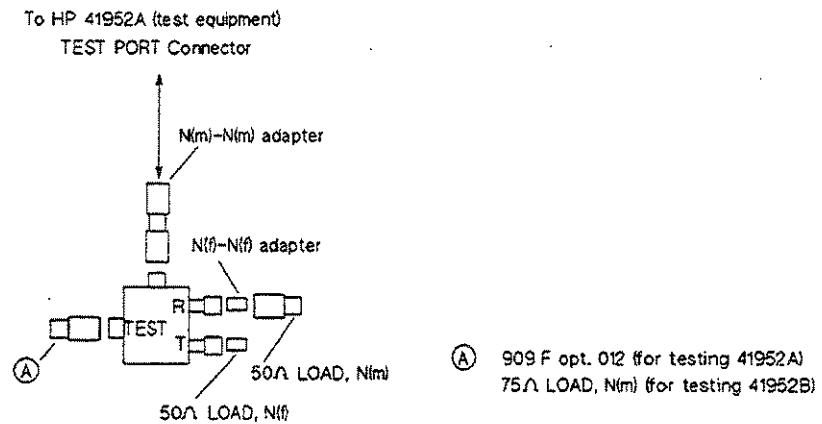

Figure 4-6. RF INPUT connector Port Match Test Setup

- Connect the HP 85032B's N(f) LOAD standard to the REFLECTED (T) connector of the HP 41952A/B (under test).
- Connect the HP 85032B's N(m) LOAD standard to the INCIDENT (R) connector of the HP 41952A/B (under test) using the N(f)-N(f) Adapter, as shown in Figure 4-6.
- Connect the RF INPUT connector of the HP 41952A/B (under test) to the adapter on the TEST PORT connector of the HP 41952A (test equipment).
- Press the HP 4195A's TRIG/RESET key to make a single sweep measurement.
- Enter the HP 4195A "A=-A" command using the following key stroke sequence to have the HP 4195A display the Port Match test results.

**CLR LINE**, blue shiftkey, **A**, =, -, (minus), **A**, ENTER/EXECUTE

- Press the **SCALE REF** key and the 'A AUTO SCALE' softkey for auto scaling.
- Press the **MKR→** key and the 'MKR→MIN' softkey to move the o marker to the minimum point.
- Confirm that the RL data displayed on the upper right corner of the HP 4195A's display (Port Match test result) is greater than or equal to 20 dB.

# PERFORMANCE TEST RECORD

Hewlett-Packard  
Model 41952A  
Transmission/Reflection Test Set

Tested by \_\_\_\_\_  
Date \_\_\_\_\_  
Serial No. \_\_\_\_\_  
Temperature \_\_\_\_\_  
Humidity \_\_\_\_\_

## DIRECTIVITY:

	Specification	Actual
Min. at $f < 300$ kHz:	$\geq 30$ dB	_____ dB
Min. at $300 \text{ kHz} \leq f \leq 200$ MHz:	$\geq 40$ dB	_____ dB
Min. at $f > 200$ MHz:	$\geq 35$ dB	_____ dB

## EFFECTIVE SOURCE MATCH:

	Specification	Actual
Min. at $f < 300$ kHz:	$\geq 15$ dB	_____ dB
Min. at $f \geq 300$ kHz:	$\geq 20$ dB	_____ dB

## PORT MATCH:

	Specification	Actual
Min. for INCIDENT:	$\geq 20$ dB	_____ dB
Min. for REFLECTED:	$\geq 20$ dB	_____ dB
Min. for RF INPUT:	$\geq 20$ dB	_____ dB

# NOTES

### SERVICE

---

**INTRODUCTION** This section contains information about replaceable parts.

---

### REPLACEABLE PARTS

The HP 41952A/B's replaceable parts are listed in Table 5-1, Replaceable Parts. Table 5-1 lists the Hewlett-Packard part number, quantity (Qty.), and gives a description.

To order a part listed in Table 5-1, indicate the Hewlett-Packard part number and quantity desired. Address the order to your nearest Hewlett-Packard office.

Table 5-1. Replaceable Parts

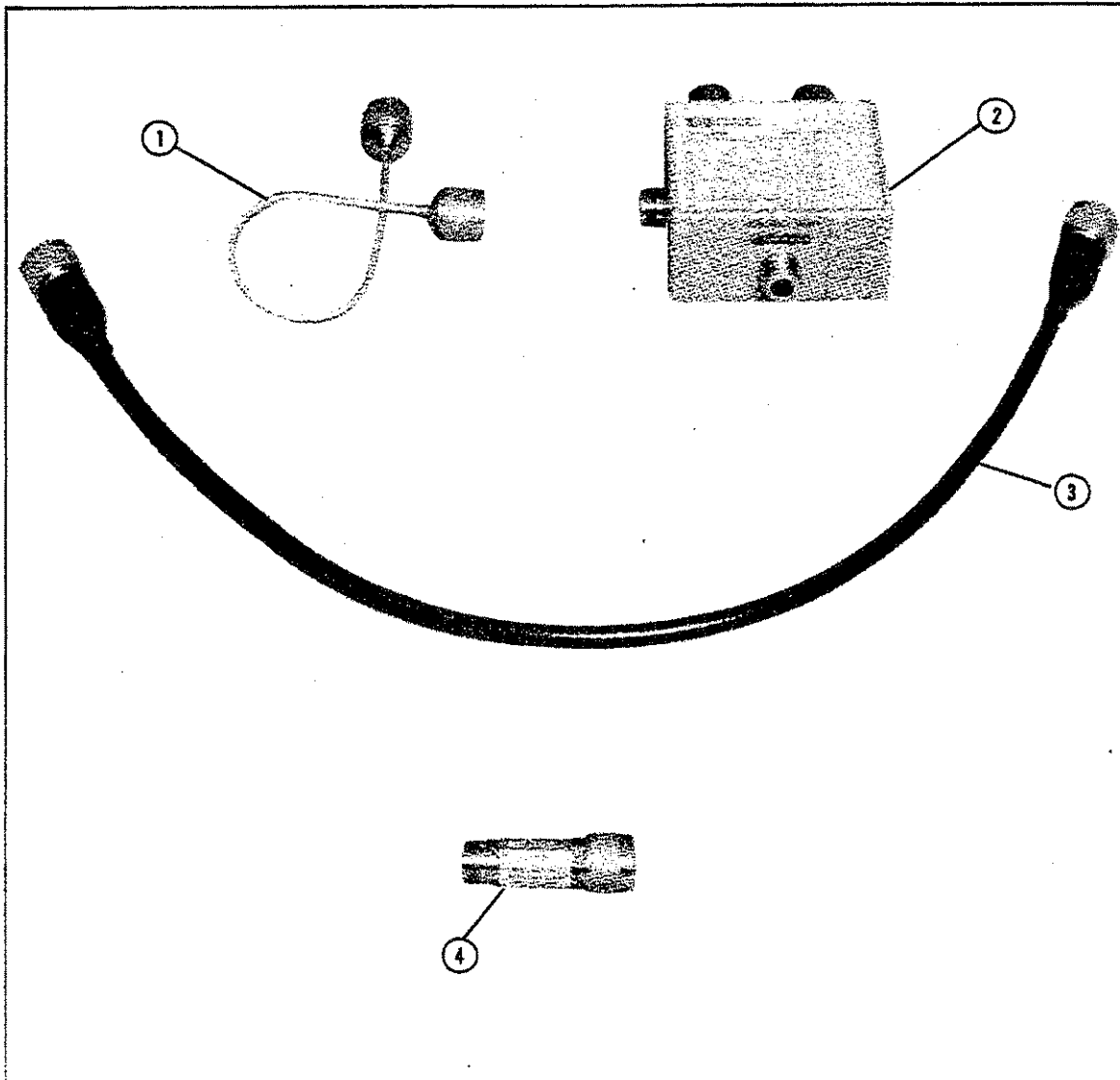

Reference Designator	Part Number	Qty.	Description
1	41952-61601	1	Cable Semi-rigid
2	41952-69001	1	Test Set 50Ω (for HP 41952A)
	41952-69002	1	Test Set 75Ω (for HP 41952B)
3	8120-4666	1	Cable Coaxial
4	11852B	1	Minimum Loss Pad (furnished with HP 41952B)





