

---

# User's Reference

Publication number 16517-97006  
January 1999

For Safety information, Warranties, and Regulatory  
information, see the pages behind the Index

© Copyright Hewlett-Packard Company 1987, 1990, 1993, 1996, 1997, 1999  
All Rights Reserved

---

## HP 16517A/18A 4-GSa/s Timing and 1-GSa/s Synchronous State Logic Analyzer

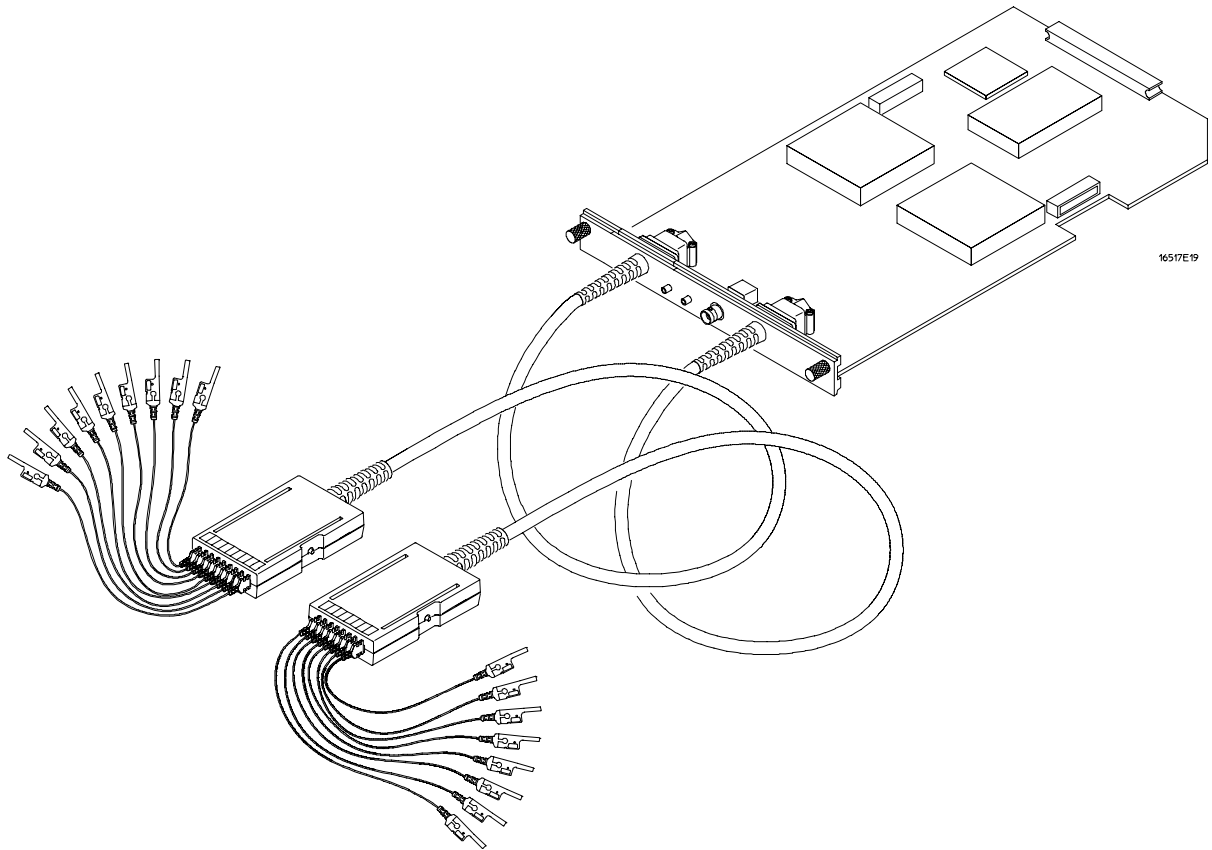

**The HP 16517A 4-GSa/S Timing and 1-GSa/S State Logic Analyzer**

---

## In This Book

The User's Reference contains field and feature definitions. Use this part of the manual set for information on what the menu fields do, what they are used for, and how the features work.

The User's Reference is divided into chapters covering general product information and probing. In addition, there are separate chapters for each analyzer menu, a chapter for markers, a chapter for error messages, and a chapter for instrument specifications.

You have the choice of using the analyzer as either a synchronous state analyzer or a timing analyzer. Some menus in the analyzer will change depending on the acquisition mode used. For example, because a timing analyzer does not use external clocks, the external clock assignment fields in the Format menu will not be available.

If a menu field is only available to a particular acquisition mode, the field is designated (Timing only) or (State only) after the field name. If no designation is shown, the field is available for both state and timing.

<b>1</b>	<b>General Information</b>	
<b>2</b>	<b>Probing</b>	
<b>3</b>	<b>The Format Menu</b>	
<b>4</b>	<b>The Trigger Menu</b>	
<b>5</b>	<b>The Listing Menu</b>	
<b>6</b>	<b>The Waveform Menu</b>	
<b>7</b>	<b>The Compare Menu</b>	
<b>8</b>	<b>The Chart Menu</b>	
<b>9</b>	<b>Markers and Stop Measurement</b>	
<b>10</b>	<b>Skew Adjust</b>	
<b>11</b>	<b>Error Messages</b>	
<b>12</b>	<b>Specifications and Characteristics</b>	
<b>13</b>	<b>Installation and Service</b>	
	<b>Index</b>	



---

# Contents

## **1 General Information**

- User Interface 1-4
- Configuration Capabilities 1-5
- Accessories Supplied 1-6
- Accessories Available 1-6

## **2 Probing**

- Probing 2-2
- Probing System Description 2-4
- Probing Accessories 2-6
- Probing Considerations 2-9
- Orientation Between Probe Tip and Interface 2-10

## **3 The Format Menu**

- Synchronous State Acquisition Mode 3-3
- Conventional Timing Acquisition Mode 3-4
- Select Clock Field (State Only) 3-5
- Set Sample Offset Field (State Only) 3-6
- Pod Threshold Field 3-8
- Label Polarity Fields 3-9
- Bit Assignment Fields 3-10
- Activity Indicators 3-12
- Symbols Field 3-12

## **4 The Trigger Menu**

- Trigger Sequence Levels 4-4
- Modify Trigger Field 4-6

## Contents

Pre-defined Trigger Macros	4-9
Using Macros to Create a Trigger Specification	4-11
Timing Trigger Macro Library	4-12
State Trigger Macro Library	4-15
Creating a User Level	4-17
Resource Terms	4-25
Assigning Resource Term Names and Values	4-27
Label and Base fields	4-31
Acquisition Control	4-32
Trigger Position Field	4-33
Sample Period Field (Timing only)	4-34
Samples/Clock Field(State only)	4-34
Armed By Field	4-37

### **5 The Listing Menu**

Markers Field	5-3
Data Roll Field	5-3
Label and Base Fields	5-4
Show States All/Ext Clock (State only)	5-5
Sample Offset Field (State only)	5-6
Specify Patterns Field	5-6
Acquisition Control Field	5-6

### **6 The Waveform Menu**

Acquisition Control Field	6-3
Accumulate Field	6-4
Seconds Per Division Field	6-5
Delay Field	6-6
Sample Period Display (Timing only) External Clock Period Display (State only)	6-7
Markers Field	6-8

Waveform Display	6-9
Display Location Reference Line	6-10
External-Clock Indicators (State only)	6-11
Blue Bar Field	6-12
Channel Mode Field	6-14
Module and Label Fields	6-16
Action Insert/Replace Field	6-17
Delete and Delete All Fields	6-18
Waveform Size Field	6-19
Sample Offset Field (State only)	6-20
Reset Statistics Field	6-20

## **7 The Compare Menu**

Reference Listing Field	7-4
Difference Listing Field	7-5
Copy Listing to Reference Field	7-7
Find Error Field	7-8
Compare Full / Compare Partial Field	7-9
Mask Field	7-10
Specify Stop Measurement Field	7-11
Data Roll Field	7-14
Bit Editing Field	7-15
Label and Base Fields	7-16

## **8 The Chart Menu**

The Y Markers	8-4
Markers Field	8-5
Rescale	8-6
Axis Control Field	8-8
Accumulate Field	8-11

## **9 Markers and Stop Measurements**

Markers Field 9-3

Pattern Markers 9-4

Find X-pattern / O-pattern Field (Listing and Chart) 9-5

Occurrence Counter Field (Listing and Chart) 9-5

From Trigger / Start / X Marker Field 9-6

X-pat / O-pat Occurrence Fields (Waveform menu) 9-7

Center Screen Field (Waveform and Chart) 9-7

X to O Display Field (Waveform and Chart) 9-7

Specify Patterns Field 9-8

Stop Measurement Field 9-10

Clear Pattern Field 9-11

Time Markers 9-12

Trig to X / Trig to O Fields 9-13

Marker Label / Base and Display (Waveform menu) 9-13

Statistics Markers 9-14

Reset Statistics Field (Waveform menu) 9-15

Clear Statistics Field (Chart menu) 9-15

## **10 Skew Adjust**

To Calibrate the Data Acquisition Module 10-2

To Adjust the Channel-to-Channel Skew 10-3

Connect the Logic Analyzer 10-3

Set Up the Logic Analyzer 10-4

To Save or Discard the Skew Factors 10-6



## 11 Error Messages

- Error Messages 11-3
- Warning Messages 11-4
- Advisory Messages 11-7
- Skew Adjust and Performance Verification Messages 11-8



## 12 Specifications and Characteristics

- Specifications 12-3
- Characteristics 12-4



## 13 Installation and Service

- To Inspect the Module 13-3
- To Prepare the Mainframe 13-3
- To Configure a One-card Module 13-5
- To Configure a Multi-card Module 13-5
- To Install the Module 13-7
- To Test the Module 13-8
  
- To Perform the Self-tests 13-9
  - Access the Self-tests 13-9
  - Perform the Functional Tests 13-10
  - Perform the Skew Adjustments and Tests 13-11
  - Exit the Self-tests 13-12
  - To Return Assemblies 13-13
  - To Clean the Logic Analyzer Module 13-13

## Index

---

Contents-6



---

## General Information

---

# Logic Analyzer Description

The HP 16517A/18A Synchronous Timing Analyzer module is part of a family of general-purpose logic analyzers. The HP 16517A/18A is a multi-card module that is used with the HP 16500 mainframes and the HP 16501A Expansion Frame.

The HP 16500 mainframe is designed for use by digital and microprocessor hardware and software designers. The HP 16500 mainframe has HP-IB, RS-232-C, and Ethernet LAN interfaces for hard copy printouts, postprocessing of measurement data, and control by a host computer.

The HP 16517A/18A analyzer can be configured in the following ways:

- The HP 16517A master can run as a single-card module or have up to four HP 16518A expansion cards added for a multi-card module.
- Channel width varies from 16 channels on the HP 16517A master, up to 80 channels when four HP 16518A expansion cards are added.
- Channel memory depth is 64 Kbytes in both full-channel state and timing modes or 128 Kbytes in half-channel timing mode.

## **Timing Modes**

The HP 16517A/18A has two timing modes. In full-channel timing mode, data is sampled at up to 2 GHz. In half-channel timing mode, data is sampled at 4 GHz.

## **Synchronous State Mode**

In the full-channel state mode, a synchronous external clock running at speeds up to 1 GHz can be used as the sample clock. In addition, the sample point can be offset to ensure a sample where you know data is valid.



Not only can you sample at the external clock transitions, but you can set the analyzer to oversample, in powers of two, up to 32x, or, up to a maximum of 2 GHz sample rate. Each point of oversampling is precisely distributed evenly within the external clock period.

### **Triggering**

Defining a trigger specification is as easy as picking a predefined macro from a trigger macro library. Trigger macros can be used by themselves or in combination with each other. Resource terms include four global patterns, two global edges, and one level dependent timer/counter. By using trigger macros, or defining your own trigger specification, the user-friendly and flexible triggering architecture lets you create a large array of trigger sequencing or qualification needed.

### **Acquisition Control**

Data storage can begin at either the start, center, end, or a user-defined point within memory. In addition, if the data of interest occurs a relatively long time after trigger, you can delay storage after a trigger by a user-defined amount. With all the acquisition control available, you can fill acquisition memory very efficiently.

### **Measurement Display**

Measurement data is displayed as waveforms or state data listings. State data can be compared bit by bit to a user-defined reference image. In the state listing, you can choose to display either sample clock transitions or both sample clock and oversampling clock transitions. In the timing waveform display, you can show state values integrated in the waveform.

## User Interface

The HP 16500 Logic Analysis System has four easy-to-use user interface devices: the knob, the touchscreen, the optional mouse (standard in the HP 16500C), and the optional keyboard.

The knob on the front panel is used to move the cursor on certain menus, to increment or decrement numeric fields, and to roll the display.

The touchscreen fields can be selected by touch or with the optional mouse. To activate a touchscreen field by touch, simply touch the screen over any dark blue box on the display with your finger until the field changes color. Then remove your finger from the screen to activate your selection. The area under your finger when you remove it from the screen is the area selected.

To activate a field with the mouse, position the cursor (+) of the mouse over the desired field and press the left button of the mouse.

The keyboard can control all instrument functions by using special function keys, the arrow keys, and the ENTER key. Alphanumeric entry is simply typed in.

All user interface devices are discussed in more detail in the HP 16500 User's Reference.

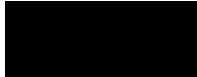

---

## Configuration Capabilities

The logic analyzer can be configured as a single- or multi-card module. The number of data channels range from 16 channels using just the HP 16517A, up to 80 channels when four HP 16518A expansion cards are connected. A half-channel acquisition mode is available which reduces the channel width by half, but doubles memory depth from 64 Kbits to 128 Kbits per channel. The configuration guide below illustrates the channel width and memory depth combinations in all acquisition modes.

**Table 1-1**

---

### Conventional Timing Modes

---

	<b>One-Card Module</b>	<b>Two-Card Module</b>	<b>Three-Card Module</b>	<b>Four-Card Module</b>	<b>Five-Card Module</b>
<b>Full Channel</b>	16 channels 64 Kbits Deep	32 channels 64 Kbits Deep	48 channels 64 Kbits Deep	64 channels 64 Kbits Deep	80 channels 64 Kbits Deep
<b>Half Channel</b>	8 channels 128 Kbits Deep	16 channels 128 Kbits Deep	24 channels 128 Kbits Deep	32 channels 128 Kbits Deep	40 channels 128 Kbits Deep

**Table 1-2**

---

### Synchronous State Mode

---

	<b>One-Card Module</b>	<b>Two-Card Module</b>	<b>Three-Card Module</b>	<b>Four-Card Module</b>	<b>Five-Card Module</b>
<b>Full Channel</b>	16 channel 64 Kbits Deep	32 channel 64 Kbits Deep	48 channel 64 Kbits Deep	64 channel 64 Kbits Deep	80 channel 64 Kbits Deep

---

## Accessories Supplied

The table below lists the accessories supplied with your logic analyzer. If any of these accessories are missing, contact your nearest Hewlett-Packard sales office. If you need additional accessories, refer to *Accessories for HP Logic Analyzers*.

**Table 1-3**

---

### Accessories Supplied

---

<b>Accessory</b>	<b>Quantity</b>
Probe Pod	2
Probe Accessory Kit	1
Cable Assembly	1
Operating system disks	1
User's Reference	1

---

## Accessories Available

There are a number of accessories available that will make your measurement tasks easier and more accurate. You will find these listed in *Accessories for HP Logic Analyzers*, available from your HP Sales Office.





Probing

---

# Probing

This chapter describes the probing system used by the HP 16517A/18A logic analyzer. It also contains information about the probing accessories, how to connect them to the probing system, and how to connect the probing system to the target system.

## **Probing Options**

You can connect the logic analyzer to your system under test in one of the following ways:

- The standard general purpose probing (provided).
- HP E2445A User-Definable Interface (optional).
- Microprocessor and bus specific interfaces (optional).

## **General-Purpose Probing**

General-purpose probing involves connecting the logic analyzer probes directly to your target system without using any interface. General purpose probing does not limit you to specific hook up schemes as, for example, the probe interface does. General-purpose probing uses grabbers that connect to both through hole and surface mount components.

General-purpose probing is the standard probing option provided with the logic analyzer. There is a full description of its components and use later in this chapter.

In addition to the supplied probing system, the logic analyzer can be connected to a target system using the following probing options:

**The E2445A User-Definable Interface**

The optional E2445A User-Definable Interface module allows you to connect the logic analyzer to the microprocessor in your target system using a breadboard which you custom wire to your system.

**The HP 16517-27601 SMA Adapter**

The optional SMA adapter allows you to connect the individual probes to SMA cables.

**Microprocessor and Bus Specific Interfaces**

The HP 16517A/18A does not support inverse assembly. In addition, the HP 16517A/18A requires that any preprocessor used be a non-terminated preprocessor. The analyzer requires a clear connection with no termination.

Microprocessors are supported by universal interfaces or preprocessor interfaces, or in some cases both. There are a number of microprocessor and bus specific interfaces available as optional accessories listed in *Accessories for HP Logic Analyzers*.

Universal interfaces are aimed at initial hardware turn-on, and will provide fast, reliable, and convenient connections to the microprocessor system.

Preprocessor interfaces are aimed at hardware turn-on and hardware/software integration, and will provide the following:

- All clocking and demultiplexing circuits needed to capture the system's operation.
- Additional status lines to further decode the operation of the CPU.
- Bus interfaces to support bus analysis for HP-IB, RS-232-C, RS-449, SCSI, VME, VXI, ISA, EISA, MCA, FDDI, Futurebus+, JTAG, SBus, PCI, and PCMCIA.

---

## Probing System Description

The analyzer probing system consists of shielded cables connected to the analyzer card on one end, and a pod housing on the other. From the pod housing, connection to the target system is through 12-inch coaxial cables connected to the assorted probing accessories at the signal end. The pod housing contains termination networks and comparators that drive open collector outputs through the main cables. In addition, located on the pod housing is an equivalent circuit illustration showing pod loading and channel indicators for the 4 GHz operation. All probe accessories connect to 0.1 inch centers.

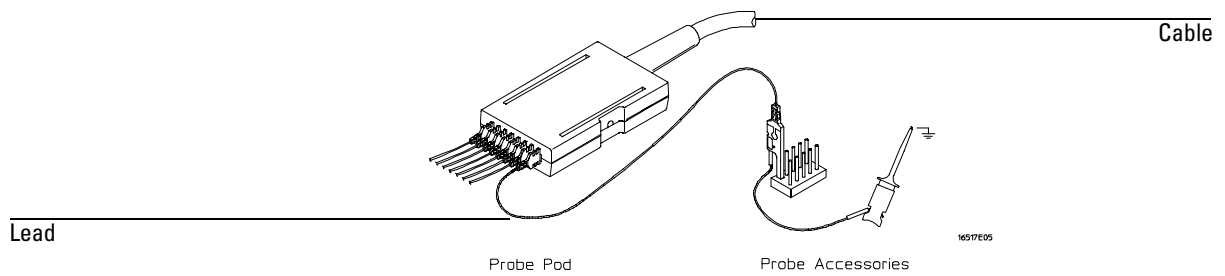

**Analyzer Probing System**

All probe cables are installed on the cards at the factory. The only user-installed components are the probe tip assemblies contained in the Probe Accessories Kit. The use of these probing accessories is described later in this chapter. Other probe system specifics are listed as follows:

#### **HP 16517A Master Card**

**Cables** Shielded, 6-foot long, contain eighteen 50- $\Omega$  transmission lines and 6 standard wires for assorted dc functions.

**Channels** Total of 17 channels. Pod 1 is the LSB (least significant byte), and has 8 data channels and 1 external clock channel. Pod 2, the MSB (most significant byte), has 8 data channels.

#### **HP 16518A Expansion Card**

**Cables** Shielded, 5-ft long, contains eighteen 50- $\Omega$  transmission lines and 6 standard wires for assorted dc functions.

**Channels** Total of 16 channels. Each pod contains 8 data channels.

---

## Probing Accessories

The probe accessories described below are part of the probe Accessory Kits supplied with the master and expander cards. To order any of these accessories individually, use the part numbers listed below or in the Accessory Kit box.

The probe accessories that plug onto straight pins will fit on 0.63 mm (0.025 in) square pins, or 0.66 mm to 0.84 mm (0.026 to 0.033 in) diameter round pins.

### Ground Leads

The following probing components connect the system to ground.

**Right Angle Ground Lead** This flexible lead is one and a half inches long with a 90 degree bend off the lead tip. It stacks on 0.1 inch centers.

Ground lead kit  
16517-82106  
Qty 20

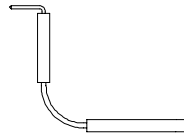

16517E07

**Ground Extender** If the circuit can tolerate an additional 0.5 to 1 pF capacitance, this socket allows stacking on 0.1 inch centers.

Ground extender kit  
16517-82105  
Qty 20

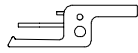

16517E08

**Ground Connector** This connector creates a 4-to-1 ground connection.

Ground connector  
16515-27601  
Qty 2

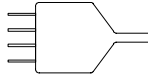

16517E09

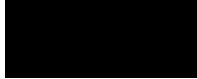

### Signal Leads

The following probing components connect the system to the signal.

**Probe Pin** The probe pin allows touch probing.

Probe pin kit  
16517-82107  
Qty 4

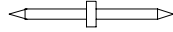

16517E10

**SMT Tack-on Signal/Ground Wire** For surface mount components, PGAs, or cramped areas, this wire can be tacked onto an IC lead for direct connection.

SMT lead kit  
16517-82104  
Qty 4 red/4 black

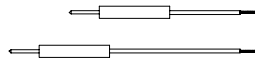

16517E11

**Grabbers** These 0.05 pitch grabbers attach to adjacent IC pins with lead spacing greater than or equal to 0.50 in.

Grabber kit  
16517-82108  
Qty 20

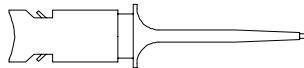

16517E12

### **Calibration Pod**

The calibration pod is only included in the Accessory Kit for the master card. You use the calibration pod during the master and expander card skew adjust. For complete skew adjust information, refer to the optional *HP 16517A/18A Service Guide*, available from your HP Sales Office. Information on adjusting skew is also available in chapter 10, "Skew Adjust."

Calibration pod  
16517-63201

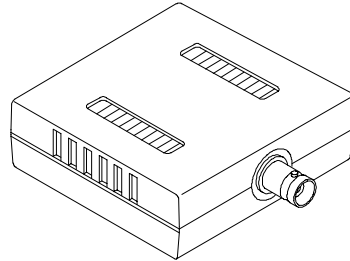

16517E13

### **BNC to SMB Cable Adapter**

On the back of the HP 16517A master card there are two SMB connectors used for external ECL arm in/out signals. Use this adapter between the BNC cable and the analyzer. The adapter cable is only included in the Accessory Kit for the master card.

BNC to SMB adapter  
16517-61604

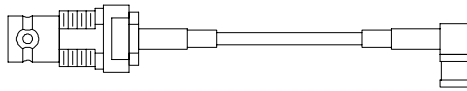

16517E14



## Probing Considerations

There are two concerns involved in all probing situations. The first concern is probe loading of the target system. The HP 16517A/18A probes are designed to eliminate this problem by providing high impedance from dc to 1 GHz. The second concern is possible inconsistent or erroneous data capture caused by lead length and improper signal and ground connections. The ideal connection is when the probe tip connects directly to the target system without any additional lead length added to the ground. Depending on your measurement, the added inductance caused by additional lead length may or may not cause a problem for the signal rise time of the target system. However, try to use the full performance configurations shown below when possible. If you must add length to the ground lead, use the following general guidelines:

**Table 2-1**

**Recommended Probe Configurations**

Target Rise time	Maximum Additional Ground Length
300 ps	1 inch
600 ps	2 inch
1 ns	3 inch

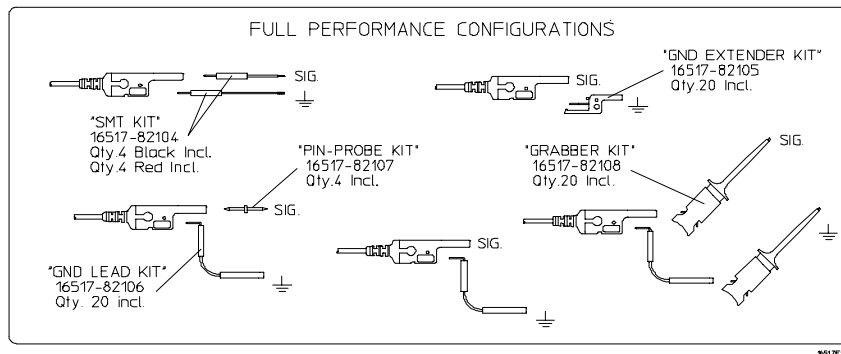

**Full Performance Configurations**

## Orientation Between Probe Tip and Interface

If you find that after all the probe connections are made, you want to track or reference a connection from the target system through the probing system into the Format menu, use the following points of identification.

- 1** Use the color coded probe tips to identify the data channel or clock channel.

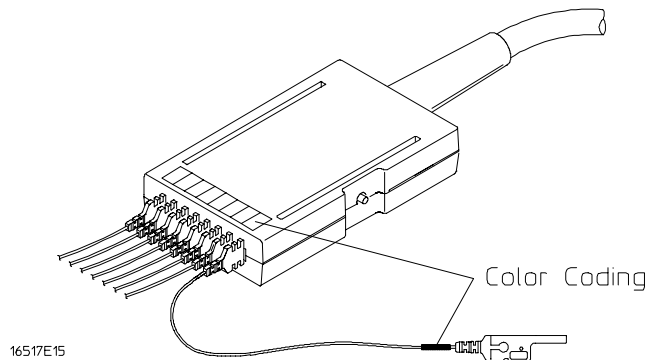

- 2** Press the Pod ID button to display the pod number on screen.  
When the Pod ID button is pressed, an advisory is displayed in all menus identifying the pod number.

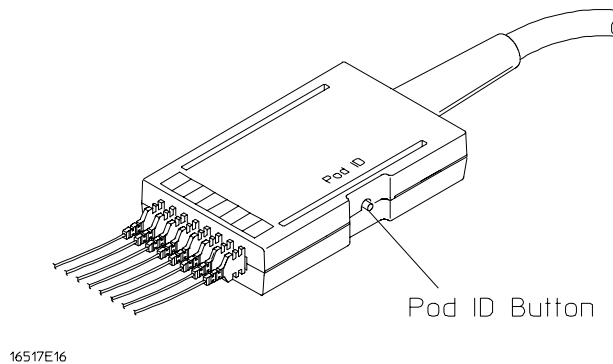

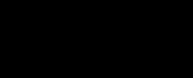

- 3 After the pod is identified, use the Activity Indicators and the Channel Reference line in the Format menu to verify activity on the data or clock channel you are referencing.

Indicators show high, low, or transitional activity while no data acquisition is in process.

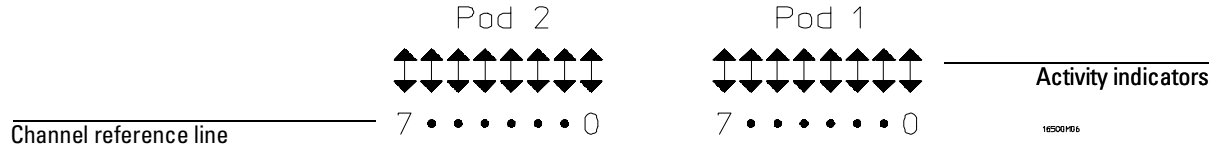

- 4 Verify that the channel is enabled within the interface by the assignment of a "\*" (asterisk) in the Bit Assignment field.

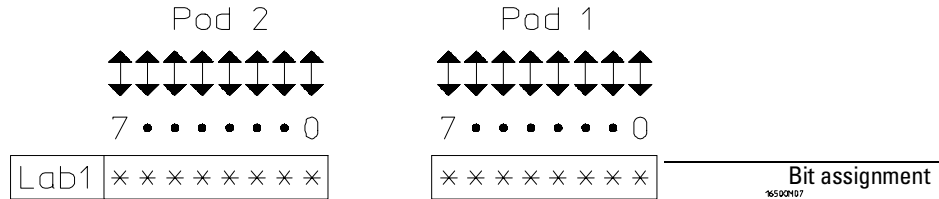

**Other Helpful Hints:**

- Use labels with meaningful names to group data within the Format menu
- When new pods are added to the module, they are added to the pod list in the Format menu. In addition, if there are more pods configured than can be displayed onscreen, use the Pods roll field to roll unseen pods back onscreen.





## The Format Menu

---

# The Format Menu

The Format menu is used to assign which data channels are measured and to group them under specific labels by function or by other identification needs. For your convenience in recognizing bit pattern groupings, you can also specify symbols to represent them.

Within the Format menu you select the acquisition mode, which in turn sets the clock source (internal or external), memory depth, and maximum sampling speed. Individual pod clock and data threshold levels are also set in the Format menu.

If the acquisition mode is set to operate as synchronous state, other fields appear which set the external clock edge and the sample clock offset. The sample clock offset allows the offset of the internal sample clock from the external clock edge to ensure the sampling of valid data.

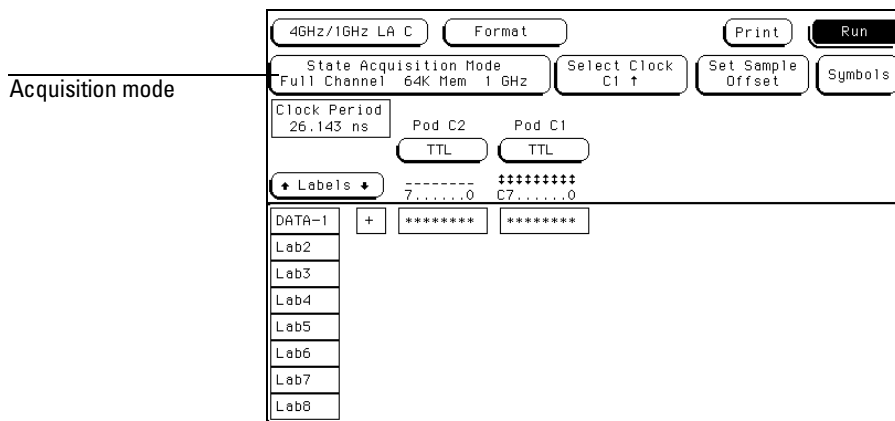

**The Format Menu**

---

## Synchronous State Acquisition Mode

The Acquisition Mode field is used to select the acquisition mode. The acquisition mode configures which clock source is used, the channel width, memory depth, and maximum sampling speed.

### State Mode Full Channel 1 GHz

In State Mode Full Channel 1 GHz, both pods are available on all configured cards. Memory depth is 64 Kbits per channel.

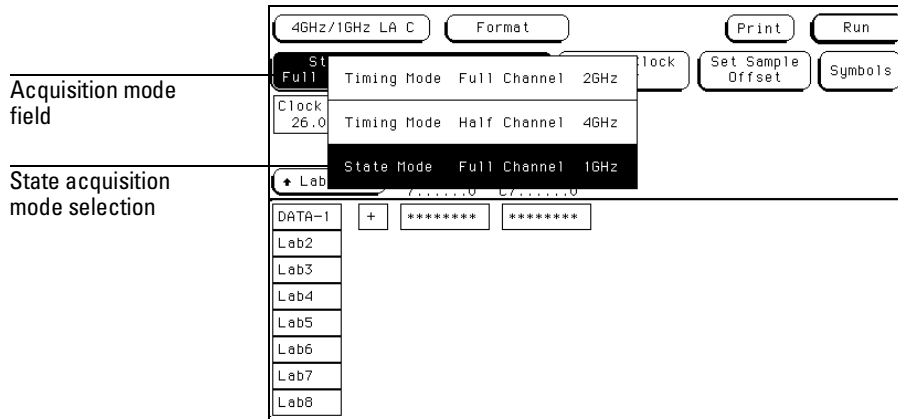

State Acquisition Mode Selection



---

## Conventional Timing Acquisition Mode

The Acquisition Mode field is used to select the acquisition mode. The acquisition mode configures which clock source is used, the channel width, memory depth, and sampling speed.

### Timing Mode Full Channel 2 GHz

In Timing Mode Full Channel 2 GHz, both pods are available on all configured cards. Memory depth is 64 Kbits per channel. The sampling speed in this mode is up to 2 GHz.

### Timing Mode Half Channel 4 GHz

In Timing Mode Half Channel 4 GHz, only bits 0 through 3 on all pods are available. However, memory depth is 128 Kbits per channel. Sampling speed in this mode is fixed at 4 GHz.

When you switch back from the half-channel mode, you are asked if you want to restore bits 4 through 7. If you answer Yes, you restore these bits to the target system in their previous On (assigned) or Off (not assigned) setting.

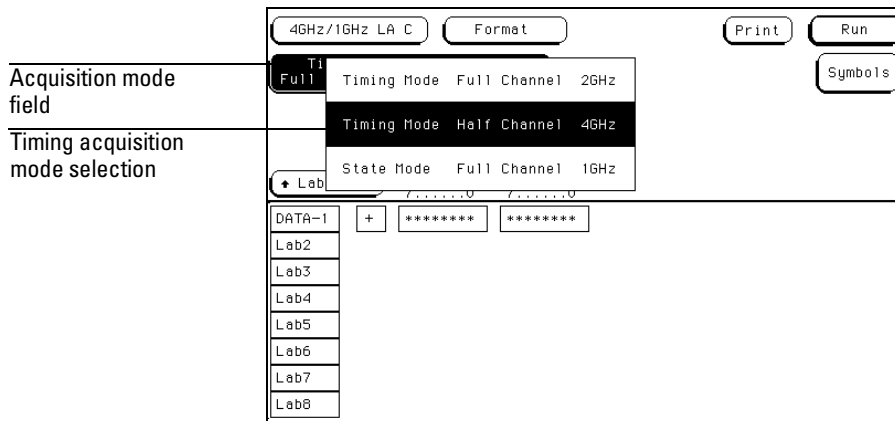

Timing Acquisition Mode Selection



---

## Select Clock Field (State Only)

In the State Acquisition mode, the external clock is connected through pod one on the master card. The Select Clock field accesses a selection pop-up from which you select the edge. The edge choices are either rising or falling.

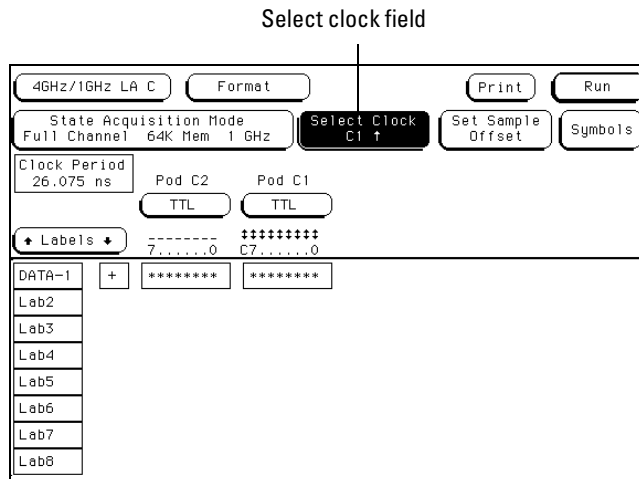

### Clock and Edge Selection

---

## Set Sample Offset Field (State Only)

The Set Sample Offset field is used to shift the point at which samples are taken with respect to the external clock edge. The Format menu is the only place where this adjustment is available.

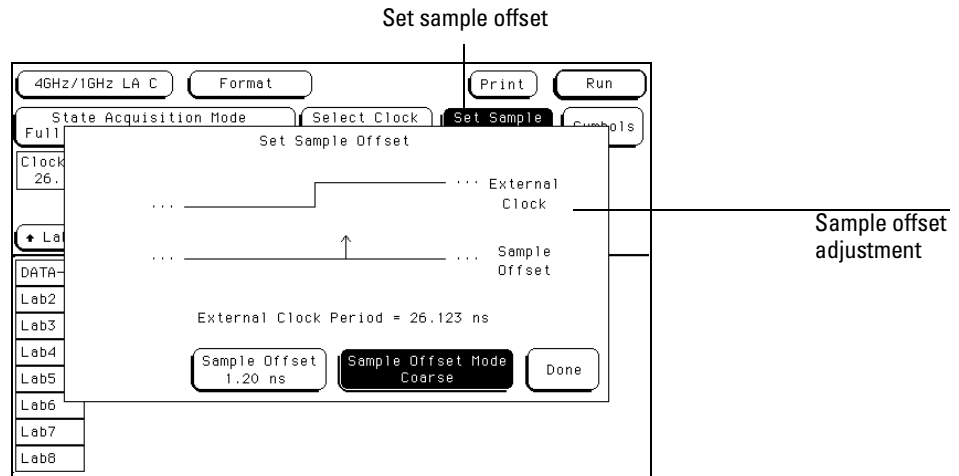

### Set Sample Offset Field

#### Sample Offset Mode

You can adjust the sample offset by using either the coarse adjustment or, if resolution is needed, the fine adjustment.

**Coarse** The coarse adjustment is the default mode. As you turn the knob, the sample point is offset from the external clock in 200 ps increments. The maximum offset is 5 ns. This adjustment affects all pods. Any coarse adjustment becomes the point from which the fine adjustment starts.

**Fine** When the Sample Offset Mode field is selected, it toggles from Coarse to Fine, and an additional Fine Adjust field becomes available. Use this field to select each individual pod, or All pods adjusted together.

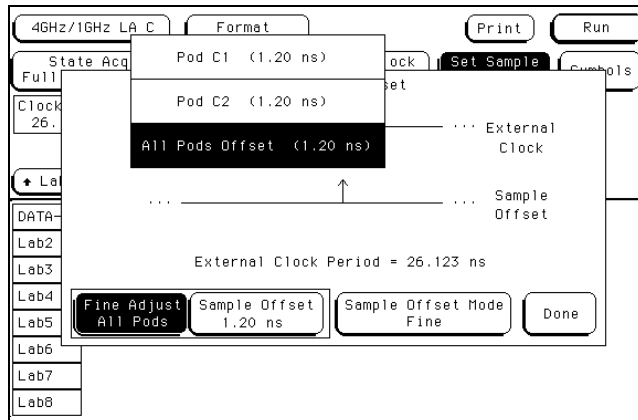

### Fine Adjustment Fields

In the Fine mode, you can offset the sample point of individual pods an additional 250 ps from the point of course adjustment within the 5 ns range. Fine adjustments are in 50 ps increments.

### Example

Your valid data appears 150 ps after the rising edge of the external clock, so offset the sample point by 150 ps.

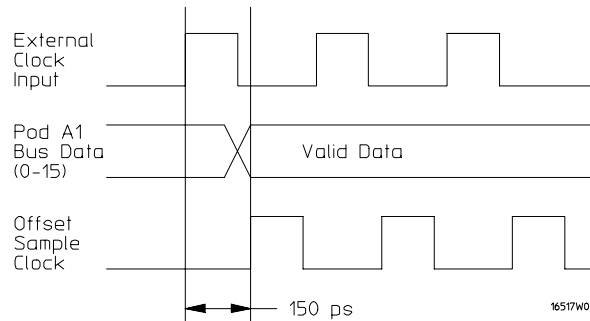

### Offsetting the External Clock



---

## Pod Threshold Field

The pod threshold field is used to set a voltage level which the data must cross before the analyzer recognizes and displays it as a change in logic levels. You specify a threshold level for each pod. The level specified for the master pod, which includes the clock, is also assigned to the clock.

**TTL** When TTL is selected as the threshold level, the data signals must cross +1.5 volts.

**ECL** When ECL is selected as the threshold level, the data signals must cross -1.3 volts.

**USER** When USER is selected as the threshold level, the data signals must cross a user selectable value between -5.0 volts to +5.0 volts.

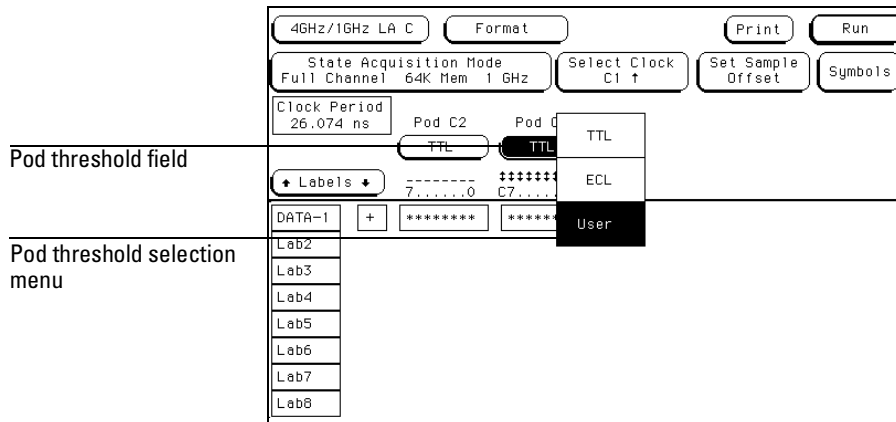

**Pod Threshold Field**

---

## Label Polarity Fields

The Label Polarity fields are used to assign a polarity to each label. The default polarity for all labels is positive (+). You change the label polarity by selecting the polarity field, which toggles the polarity between positive (+) and negative (-).

When the polarity is inverted, all data and bit pattern specific configurations used for identifying, triggering, or storing data reflect the change of polarity.

In a timing analyzer with the data inverted, the waveform display does not change.

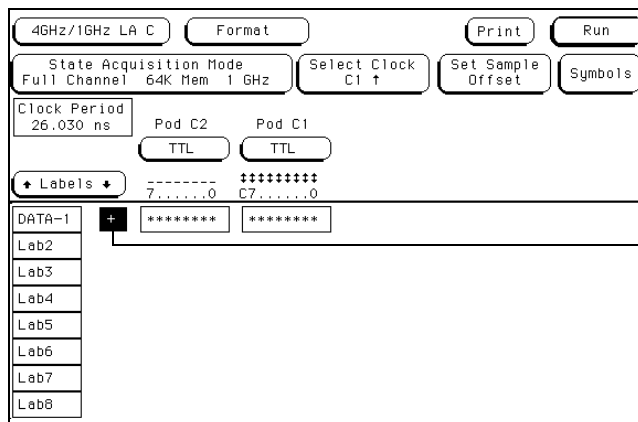

Polarity field

**Polarity Field**



---

## Bit Assignment Fields

The bit assignment fields are used to assign bits (channels) to labels. The convention for bit assignment is as follows:

- \* (asterisk) indicates assigned bit.
- . (period) indicates unassigned bit.

To change a bit assignment, select the bit assignment field and move the cursor to the bit you want to change, then select an asterisk or a period. When the bits are assigned as desired, close the pop-up. The screen displays the new bit assignment.

Above each column of bit assignment fields is a bit reference line that shows you the clock bit, and the eight data bits with the left bit numbered 7 and the right bit numbered 0. This bit reference line helps you know exactly which bits are connected by displaying activity indicators when a proper connection from the probe is recognized.

### See Also

"Activity Indicators," later in this chapter, for more information on how to read the activity indicator display.

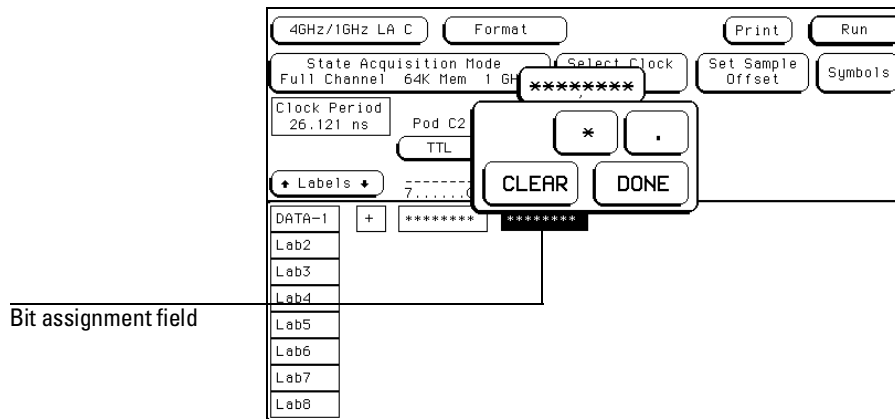

### Bit Assignment Field

Labels may have from 1 to 32 channels assigned to them. If you try to assign more than 32 channels to a label, the logic analyzer will beep, indicating an error, and a message will appear at the top of the screen telling you that 32 channels per label is the maximum.

Channels assigned to a label are numbered from right to left by the logic analyzer. The least significant assigned bit on the far right is numbered 0, the next assigned bit is numbered 1, and so on. Since 32 channels can be assigned to one label at most, the highest number that can be given to a channel is 31.

Although labels can contain split fields, assigned channels are always numbered consecutively within a label.

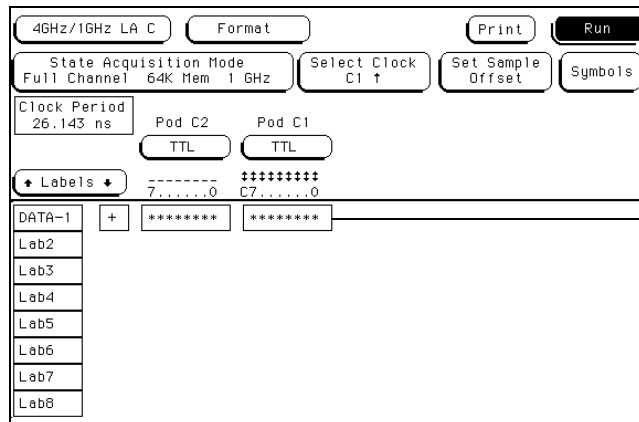

Assigned Channels

Assigned Channels Example



---

## Activity Indicators

When the logic analyzer is properly connected to an active target system, you see either a high level dash, a low level dash, or a transitional arrow in the Activity Indicator displays for each pod probe. These indicators are very useful in showing proper probe connection and that the logic levels are as expected according to the threshold level setting. The Activity Indicators are not displayed during an acquisition.

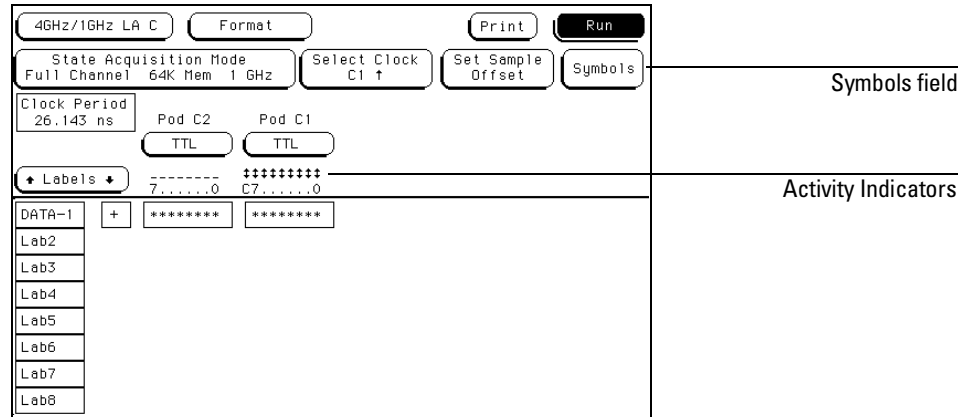

### Activity Indicators

---

## Symbols Field

Symbols are used in place of ambiguous data values in data listings. A custom symbol name, relevant to the measurement, can be easily spotted in a long list of data.

**See Also**

"Symbols Assignment" chapter in the Common Module Operations section of the *HP 16500 Logic Analysis User's Reference* for complete information on assigning symbols.





---

## The Trigger Menu

---

# The Trigger Menu

The Trigger menu is used to configure when the analyzer triggers, and what the analyzer triggers on. In addition, within the Acquisition Control function, prestore and poststore requirements are set. The Trigger menu is divided into three areas, each dealing with a different area of general operation.

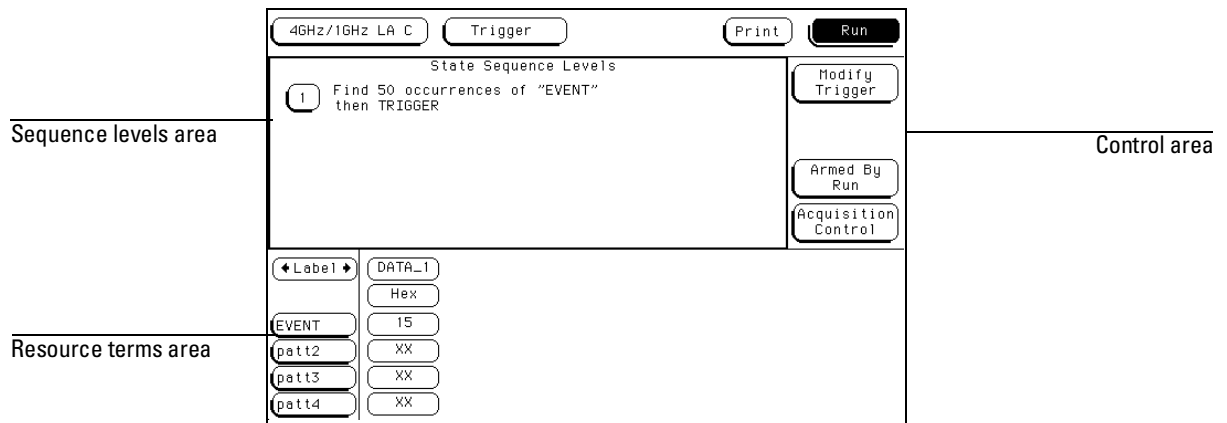

**Trigger Menu Areas**

**Sequence Levels**

The sequence levels area is where you view the sequence levels currently used in the trigger specification. From this area you can also access each individual level for trigger modifications.

**Resource Terms**

The resource terms area is where you assign values to the user-definable resource terms. These terms take the form of bit patterns and edges. From this area, you also make changes to the default term names.

**Control Area**

The acquisition control area is where you define any external trigger control and at what point within acquisition memory the data storage begins.

By using resource terms, timers, and occurrence counters in the predefined trigger macros, you easily position the data acquisition in the data stream where you want. In addition, by using prestore and poststore control, you use the available memory efficiently.



---

## Trigger Sequence Levels

Sequence levels control when the analyzer triggers, what the analyzer triggers on, and where trigger is located in the collected data. By using sequence levels, you can create a sequence of instructions for the analyzer to follow. As the sequence levels are executed by the analyzer, all subsequent branching and sequence flow is directed by the statements within the sequence levels. The path taken resembles a flow chart, and the end result is the desired trigger point.

A trigger sequence is made up of trigger macros, user-defined sequence levels, or a combination of both. Both the predefined macros and user-defined sequence instructions may contain timers, occurrence counters, and resource terms representing edges and bit patterns. The analyzer has up to 4 sequence levels available.

### **Sequence Level Types**

Constructing sequence statements using the trigger macros or user-defined statements will result in two different kinds of sequence levels.

When predefined trigger macros are used, more than one of the available four sequence levels may be required for a single macro. The exact number of internal levels required per macro is shown within the macro library list.

When the user-mode is used, all four sequence levels are available. However, sequence levels are used up one level at a time.

Even though you may use multiple sequence levels when using trigger macros, macros are easier to use, and may be the most efficient way to construct a trigger specification.

### Editing Sequence Levels

Since constructing a trigger specification may be an iterative process, editing sequence levels may become the same kind of iterative process.

The higher level editing, such as adding or deleting entire sequence levels, is done using the Modify Trigger field in the main Trigger menu. You can also enter any existing sequence level from the Modify Trigger field. Another way of editing a specific sequence level is to select the sequence level number field.

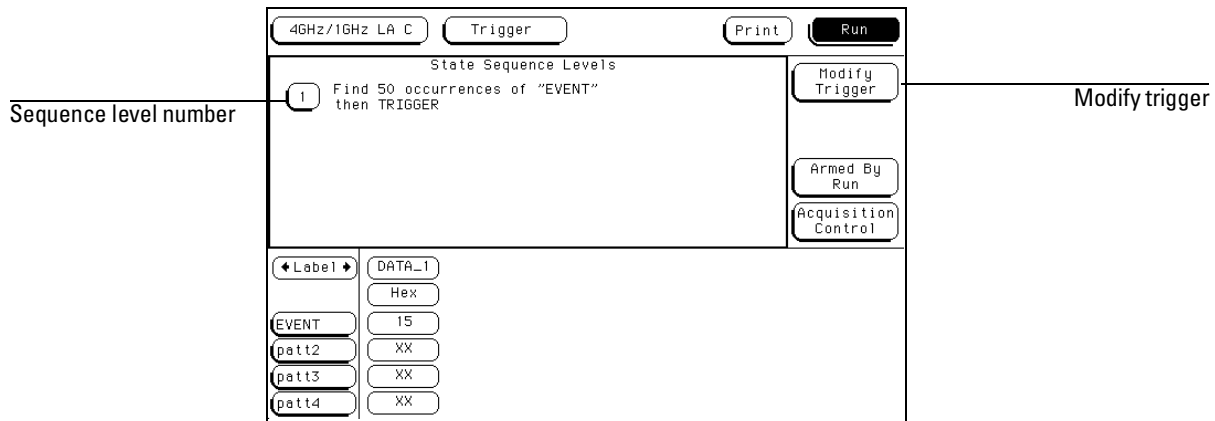
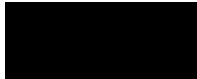

### Accessing Sequence Levels

Once you are in any sequence level, you configure the sequence statement using predefined macro statements or user-defined statements. All appropriate resource terms appear in pop-up selection lists after any of the assignment fields within a sequence level are selected.

---

## Modify Trigger Field

The Modify Trigger field accesses a selection menu with choices that allow you to modify the statements of any single sequence level. In addition, other high level actions can be accessed, like global clearing of existing trigger statements, and adding or deleting sequence levels.

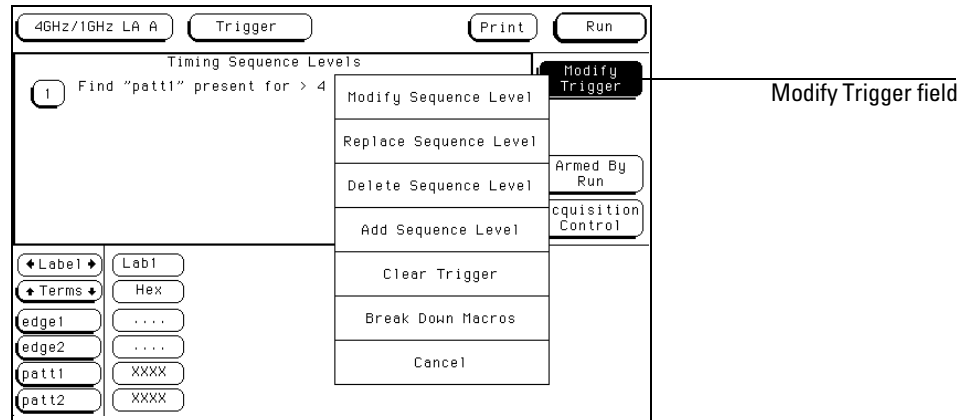

### Modify Trigger Menu

#### Modify Sequence Level

If there is more than one sequence level assigned, you are asked which level to modify. Once in the desired sequence level, make all appropriate resource changes, then select Done.

#### Replace Sequence Level

If there is more than one sequence level assigned, you are asked which level to replace. When you replace a level, you pick a new macro or user-level, and it then replaces the old one. You then assign the appropriate resource in the new level.

### **Delete Sequence Level**

If there is more than one sequence level assigned, you are asked which level to delete.

### **Add Sequence Level**

By default you have one sequence level available at power up. When you add sequence levels, you are given the choice of inserting them before or after a sequence level.

### **Clear Trigger**

The Clear Trigger field accesses a selection menu used to clear any user-defined values within the trigger specification or within the resource terms list.

**Clear All** The Clear All option clears sequence levels, resource terms, and resource term names back to their default values.

**Clear Sequence Levels** The Clear Sequence Levels option resets all assignment fields in the sequence levels to their default values. Any custom names assigned to the resource terms will remain.

**Clear Resource Terms** The Clear Resources Terms option will reset all assignment fields for the resource terms back to their default values.

**Clear Resource Term Names** The Clear Resource Term Names option resets all custom names assigned to the resource terms back their default values.

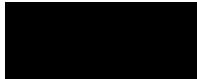

### **Break Down Macros / Restore Macros**

When a macro is broken down, the contents of that macro are displayed in long form used in a user-defined sequence type. If the macro uses two internal levels, both levels are separated out and displayed in the sequence level area of the Trigger menu.

Once the macros in your trigger specification are broken down, the Break Down Macros field changes to Restore Macros. Use the Restore Macros field to restore all macros to their original structure. While in a broken down form, you can change the structure. However, when the macros are restored, all changes are lost and any branching that is part of the original structure is restored.

Use the Break Down Macros if you want to view a particular macro part in its long form to see exactly what flow the sequencer is following. There may be a custom trigger specification that requires a modification in the macro's long form.

When a macro is broken down, you see the macro in its long form User-defined sequence type. This means you have all the resource assignment fields and branching options available. For information on the assignment fields, branching, occurrence counters, and time duration function, refer to the section, "Creating a User-Level", found later in this chapter.



---

# Pre-defined Trigger Macros

Both the state and timing acquisition modes have a macro library containing predefined trigger macros. Depending on which acquisition mode you are using, you get the corresponding library.

Each macro will require at least one sequence level, and in some cases, may require multiple levels. Other than one sequence level being followed by another, macro levels do not branch out of this order. However, macros can be branched to, by combining a user-defined level with a macro level.

### Timing Trigger Macro Library:

- User Mode (user-defined macro)
- Basic Macros
- Pattern/Edge Combination Macros
- Setup/Hold Violation Macros
- Time Violation Macros
- Delay Macros

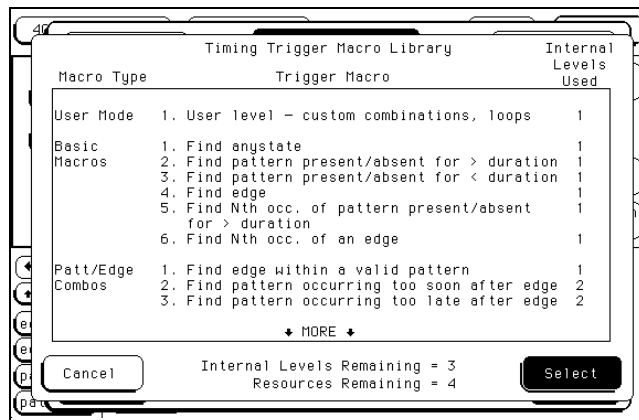

### Timing Trigger Macro Library

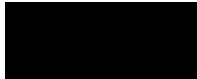

**State Trigger Macro Library:**

- User Mode (user-defined macro)
- Basic Macros
- Sequence Dependent Macros
- Time Violation Macros
- Delay Macros

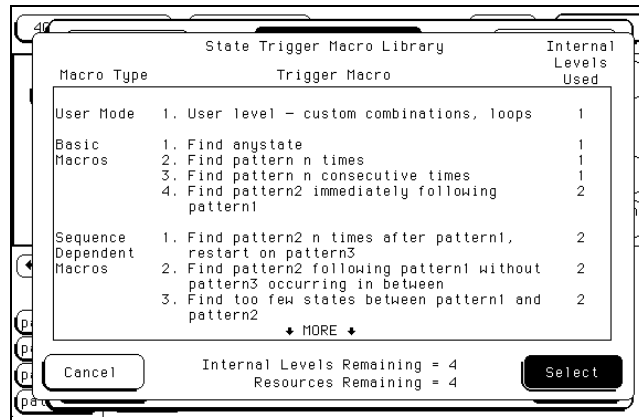

**State Trigger Macro Library**

---

## Using Macros to Create a Trigger Specification

To configure a trigger specification using trigger macros, follow the procedure below.

- 1 From the Trigger menu, enter the desired sequence level through the Modify Trigger field, or by selecting a sequence level number.

**See Also**

"Editing Sequence Levels" and "Modify Trigger Field" found earlier in this chapter for information on accessing levels.

- 2 From within the sequence level, select the Select New Macro field.

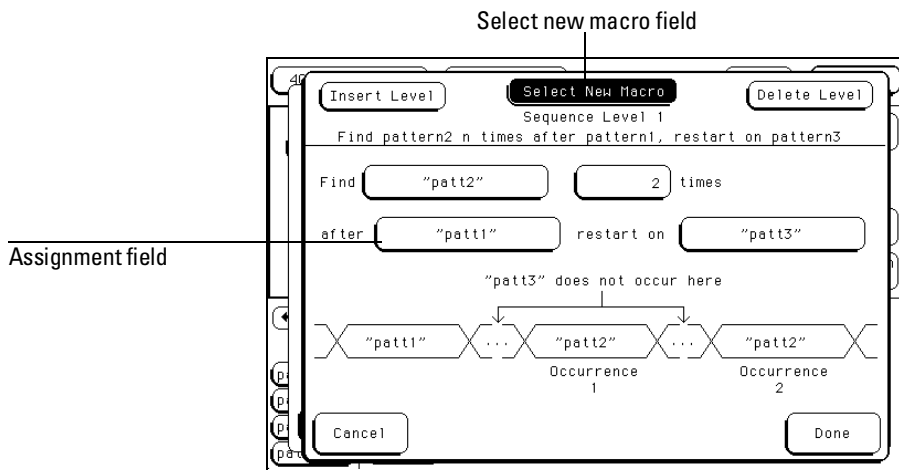

### Select New Macro Field

- 3 Scroll and highlight the macro you want, then select the Select field.
- 4 Select the appropriate assignment fields and insert the desired predefined resource terms, numeric values, and other parameter fields required by the macro. Select the Done field.

**See Also**

"Resource Terms" found later in this chapter for information on using predefined resource terms.

## Timing Trigger Macro Library

The following list contains all the macros in the Timing Trigger Macro Library. They are listed in the same order as they appear onscreen.

### User Mode

#### **User level - custom combinations, loops**

The User level is a user-definable level. This level offers low level configuration and uses one internal sequence level.

### Basic Macros

#### **1. Find anystate n times**

This macro becomes true when the first state it sees appears "n" times. It uses one internal sequence level.

#### **2. Find pattern present/absent for > duration**

This macro becomes true when it finds a designated pattern that has been present or absent for greater than or equal to the set duration. It uses one internal sequence level.

#### **3. Find pattern present/absent for < duration**

This macro becomes true when it finds a designated pattern that has been present or absent for less than the set duration. It uses one internal sequence level.

#### **4. Find edge**

This macro becomes true when the designated edge is seen. It uses one internal sequence level.

#### **5. Find Nth occurrence of pattern present/absent for > duration**

This macro becomes true when it finds the Nth occurrence of a pattern that has been present or absent for greater than or equal to the set duration. Each valid pattern occurrence is only counted once, even though the same occurrence may be valid for multiple sample clocks. It uses one internal sequence level.

## 6. Find Nth occurrence of an edge

This macro becomes true when it finds the designated occurrence of a designated edge. It uses one internal sequence level. The 500 MHz trigger sequencer may not count edges captured closer than 2 ns apart.

Pattern/Edge  
Combinations

### 1. Find edge within a valid pattern.

This macro becomes true when a selected edge type is seen within the time window defined by a designated pattern. It uses one internal sequence level.

### 2. Find pattern occurring too soon after edge

This macro becomes true when a designated pattern is seen occurring within a set duration after a selected edge type is seen. It uses two internal sequence levels.

### 3. Find pattern occurring too late after edge

This macro becomes true when one selected edge type occurs, and for a designated period of time after that first edge is seen, a pattern is not seen for a designated time period. It uses two internal sequence levels.

Setup/Hold  
Violations

### 1. Find setup or hold violation

This macro becomes true when there is a change on a selected group of channels which violates the specified setup or hold time criteria with respect to a selected edge. It uses two internal sequence levels.

### 2. Find setup or hold violation clocked by an edge within a valid pattern

This macro becomes true when either a designated setup or a hold criterion is violated on a selected group of channels which are being clocked by a selected edge which appears within a designated pattern. It uses two internal sequence levels.

### 3. Find setup or hold violation clocked by a pattern/pulse

This macro becomes true when there is a change on a selected group of channels which violates the specified setup or hold time criteria with respect to a selected pattern. It uses three internal sequence levels.



Time Violations

**1. Find two edges too close together**

This macro becomes true when a second selected edge is seen occurring within a designated period of time after the occurrence of a first selected edge. It uses two internal sequence levels.

**2. Find two edges too far apart**

This macro becomes true when a second selected edge occurs beyond a designated period of time after the first selected edge. It uses two internal sequence levels.

**3. Find width violation on a pattern/pulse**

This macro becomes true when the width of a pattern violates designated minimum and maximum width settings. It uses one internal sequence level.

Delay

**1. Wait t seconds**

This macro becomes true after a designated time period has expired. It uses one internal sequence level.

---

## State Trigger Macro Library

The following list contains all the macros in the State Trigger Macro Library. They are listed in the same order as they appear onscreen.

### User Mode

#### **User level - custom combinations, loops**

The User level is a user-definable level. This level offers low-level configuration and uses one internal sequence level.

### Basic Macros

#### **1. Find anystate n times**

This macro becomes true when the first state it sees appears n times. It uses one internal sequence level.

#### **2. Find pattern n times**

This macro becomes true when it sees a designated pattern occurring a designated number of times consecutively or nonconsecutively. It uses one internal sequence level.

#### **3. Find pattern n consecutive times**

This macro becomes true when it sees a designated pattern occurring a designated number of consecutive times. It uses one internal sequence level.

#### **4. Find pattern 2 immediately following pattern 1**

This macro becomes true when the first designated pattern is seen immediately followed by a second designated pattern. It uses two internal sequence levels.

### Sequence

#### Dependent macros

#### **1. Find pattern 2 "n" times after pattern 1, before pattern 3 occurs**

This macro becomes true when it first finds a designated pattern 1, followed by a selected number of occurrences of a designated pattern 2. In addition, if a designated pattern 3 is seen anytime while the sequence is not yet true, the sequence starts over. If pattern 2's "nth" occurrence is coincident with pattern 3, the sequence starts over. It uses two internal sequence levels.



**2. Find too few states between pattern 1 and pattern 2.**

This macro becomes true when a designated pattern 1 is seen, followed by a designated pattern 2, and with less than a selected number of states occurring between the two patterns. It uses two internal sequence levels.

**3. Find too many states between pattern 1 and pattern 2.**

This macro becomes true when a designated pattern 1 is seen, followed by at least a selected number of states, then followed by a designated pattern 2. It uses two internal sequence levels.

Time Violations

**1. Find pattern 2 occurring too soon after pattern 1**

This macro becomes true when a designated pattern 1 is seen, followed by a designated pattern 2, and with less than a selected time period occurring between the two patterns. It uses two internal sequence levels.

**2. Find pattern 2 occurring too late after pattern 1**

This macro becomes true when a designated pattern 1 is seen, followed by at least a selected time period, before a designated pattern 2 occurs. It uses two internal sequence levels.

Delay

**1. Wait n external clock states**

This macro becomes true after a designated number of user clock states have occurred. It uses one internal sequence level.



---

## Creating a User Level

Before you begin to program a trigger specification using user-defined sequence levels, consider that in most cases one of the trigger macros will work.

A trigger macro library is available with pre-defined sequence statements already built for you. By using the trigger macros you can quickly form a trigger specification that contains all the steps required to trigger at the desired point. Simply select the macro and assign values to the resource terms.

However, if you need to configure a user-defined sequence level to accommodate a specific condition, or you prefer to construct a trigger specification from scratch, the following information and examples will help guide you conceptually through the task.

**See Also**

"Pre-defined Trigger Macros" found earlier in this chapter for complete information on the available trigger macros for the different kinds of measurements.

### User-defined Sequence Levels

If you build your own trigger specification or modify a macro, you will use resource terms, timers, counters, and combination terms. Each sequence level has a "fill-in-the-blanks" type statement to start with. Depending on what you place in the assignment fields, you may cause more assignment fields to appear. When each assignment field is selected, a list of available resource term choices appears.

**See Also**

"Resource Terms" found later in this chapter for more information on the resource terms and how they work.

When creating a sequence statement, the typical method during a debug operation is to first trigger on a simple pattern or edge. From that point, it becomes an iterative process of adding or tuning sequence levels until you consistently trigger at the desired point.

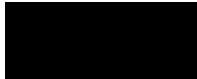

## The Trigger Menu Creating a User Level

The steps in this kind of process are difficult to predict, but the general approach is to think of each sequence level as an opportunity to direct the analyzer's selection process in the desired direction.

During sequence execution, the analyzer searches for a match between the resource term value and the measurement data. When a match is seen, that part of the sequence statement becomes true and the sequencing continues to the next sequence level. Eventually a path of "true" resource terms leads to your trigger command.

The typical User Level shown below is where you create or modify the sequence instruction by selecting the assignment fields and inserting resource term choices into each assignment field.

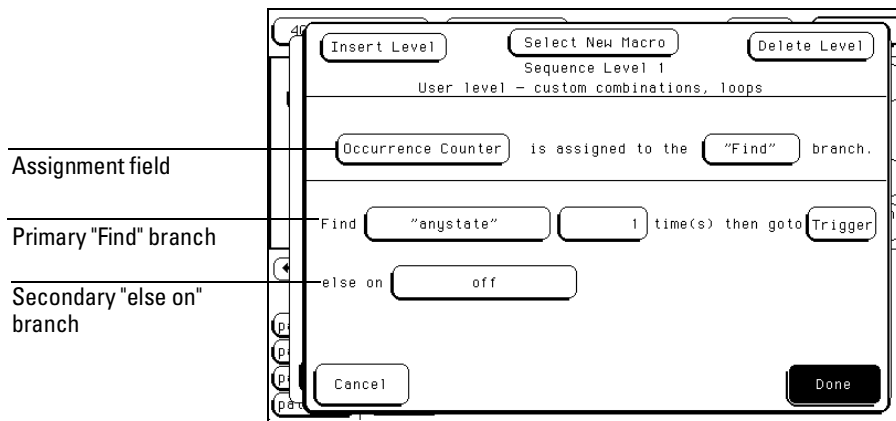

### Sequence Level Menu

The actual resource terms available for any particular assignment field varies on such things as the acquisition mode, if the timer or occurrence counter is used, and how many resource terms have already been used in other levels.

### See Also

"The Trigger Sequencer" section in chapter 4, "Concepts," in the *HP 16500/16501A Logic Analysis System User's Guide*. The User's Guide is distinct from the User's Reference and contains supplementary information.

### Using Bit Patterns and Edges

Bit patterns and edges can be used by themselves or in combination. Bit patterns are set to match specific data values, and in the timing acquisition mode, edges are set to match specific edges of a timing pulse.

---

#### Example

The following statement looks for the bit pattern you assigned to the term patt1 to occur 2 times, before it branches to sequence level 3:

Find **patt1 2** time(s) then goto **3**

---

---

#### Example

The following statement looks for a positive, negative, or either going edge you assigned to term edge1 to occur 1 time, before it triggers:

Find **edge1 1** time(s) then goto **Trigger**

---

---

#### Example

The following statement looks for the combination of either a bit pattern (patt1) or an edge (edge1) to occur 1 time before it triggers:

Find **patt1+edge1 1** time(s) then goto **Trigger**

---

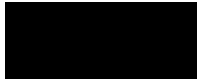

### Setting Pattern Durations (Timing only)

When a bit pattern is found during a timing sequence evaluation, you can influence when the term actually becomes "true" by assigning a time duration. This works very similar to how the occurrence counter influences terms. The Set Pattern Duration field appears in all levels. The duration assignment menu is accessed by selecting the Set Pattern Duration field.

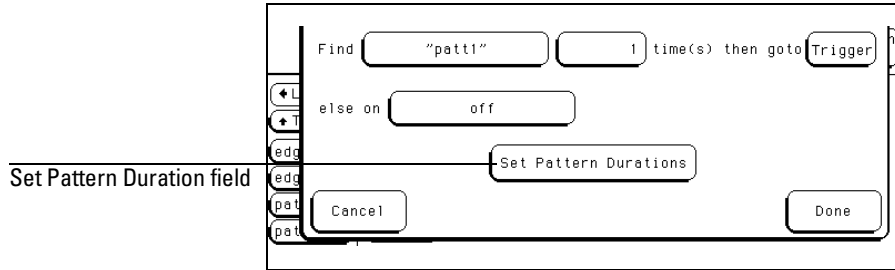

### Set Pattern Duration Field at bottom of Sequence Level Menu

Pattern duration is assigned by sequence level and only to the resource terms being used in that level. This means that you could set different durations to the same term name in a different sequence level. However, each time you use that same term with different duration values, and in different sequence levels, you use up another resource. In other words, there is no difference between using one resource term four times with different pattern durations, and using four different resource terms once each.

### See Also

"Resource Terms" section found later in this reference for more information on resource terms definition and usage.

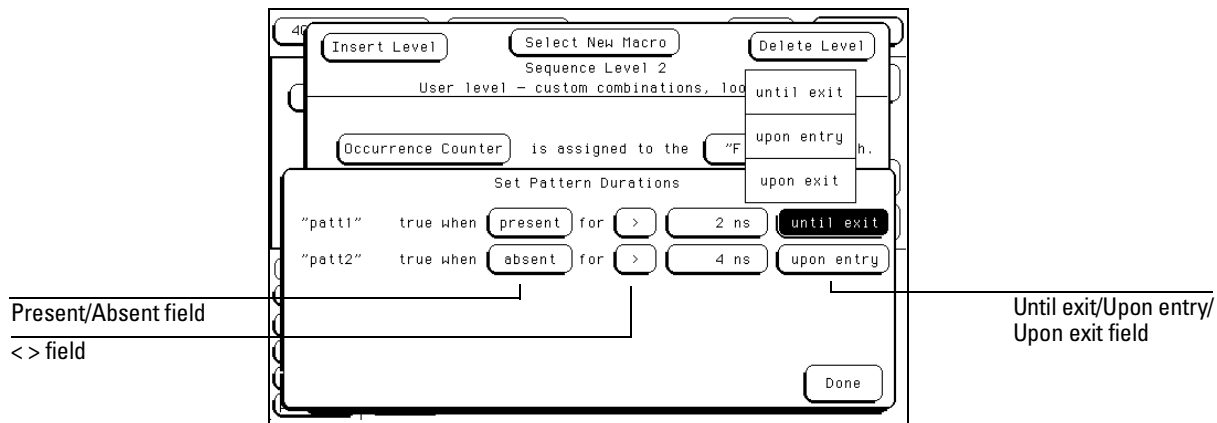

### Duration Assignment Menu

**Present/Absent Field** This field determines whether the resource becomes true when the bit pattern is present or absent for the specified time interval.

**< > Field** This field allows you to choose whether the pattern duration is longer or shorter than the specified time. When (<) is selected, the resource is true for one clock cycle after a pattern is present/absent for less than the duration value. When you select (<), the until exit/upon entry/upon exit field disappears.

When (>) is selected, additional control over pattern duration becomes available. This control allows you to pick what happens after the pattern has been present/absent for more than the duration value.

**Until exit/ Upon entry/ Upon exit Field** This part of the Set Pattern Duration statement dictates how long the resource is true after the pattern duration is met. The Until Exit selection keeps the resource true from the time the duration is met, until the end of the pattern. The Upon Entry selection makes the resource true for only one clock cycle after the duration is met. The Upon Exit selection makes the statement true for one clock cycle after the end of the pattern.

### Using the Timer

The timer is started as the sequence level is entered. If you return to the same sequence level again, the timer will be restarted. If you choose to use the timer in a sequence level, the occurrence counter is not available in that level.

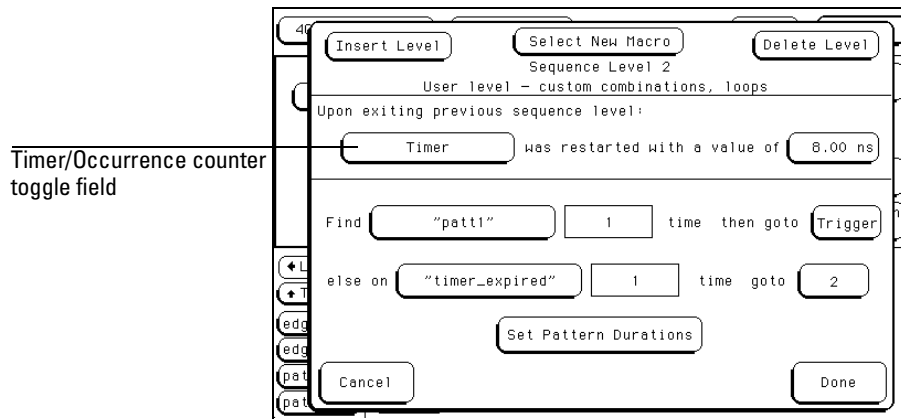

### Sequence Level Menu with Timer

---

#### Example

The following statement assigns the Timer to count down from 4 ns when the sequence level is entered.

Upon exiting previous sequence level:

**Timer** was restarted with a value of **4 ns**

---

#### Example

The following statement tells you that if the primary "Find" branch is not taken before the Timer expired, you will take the secondary branch to an immediate Trigger command.

else on **Timer expired** 1 time goto **Trigger**

---

### Using the Occurrence Counters

The occurrence counter is assigned to either the "Find" branch or the "else on" branch. Whatever positive number you assign to the counter, the pattern must be seen that number of times before the term becomes true.

It should be noted that in order to count occurrences of a pattern with a > duration, the Upon Entry or Upon Exit selections should be used. In the Until Exit mode, the occurrence counter is clocked at a 2 ns rate as long as the resource is true, in effect acting like a duration counter.

If the "else on" branch becomes true before all specified occurrences of the primary branch, the secondary "else on" branch is taken.

If you choose to use the occurrence counter in a sequence level, the timer is not available in that level.

---

#### Example

The following statement assigns the Occurrence Counter to the primary "Find" branch. Once the Occurrence Counter is assigned, a new assignment field appears in the primary branch to set occurrences.

**Occurrence Counter** is assigned to the **"Find"** branch

Find **patt1 3** time(s) then goto **Trigger**

---

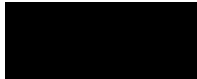

### Branching

Each of the four sequence levels has one primary branch and one secondary branch. If the primary branch is taken, the destination is directed by the "Find" statement. If the secondary branch is taken, the destination is directed by the "else on" statement. The primary branch must be used whereas the secondary branch can be turned off.

If both branch statements are simultaneously met, the primary branch will be taken. Both branches can be directed to any active sequence level or to the Trigger. When the trigger is seen, sequencing is over and the poststore counter begins counting down to zero, at which time data storage is over.

### See Also

"Acquisition Control" section for more information on configuring memory to store posttrigger data.

---

### Example

The following statement instructs the analyzer to start the Timer as the sequence level is entered. It then will have 8 ns to find the bit pattern you assigned to "patt1." If it finds "patt1," then the analyzer triggers. If it doesn't find "patt1" in 8 ns, the sequence evaluation branches to sequence level 2.

Upon exiting previous sequence level:

```
Timer was restarted with a value of 8 ns  
Find patt1 1 time then goto Trigger  
else on Timer expired 1 time goto 2
```

---



---

## Resource Terms

The analyzer has four resources and one timer/counter. The four resources can be represented by up to six resource term names, patt1–patt4 bit patterns, and edges 1–2 (timing only). The pattern and edge terms are used in any of the four sequence levels.

Once you assign the four resources with both a resource term name and a value, the resources can be used either by themselves or in combination with each other. It is possible to have up to six resource term names assigned to different pattern and edge values, however, you will only be allowed to insert up to four of them in the total trigger specification.

Pattern duration is assigned per sequence level. This means that you could assign a different duration to the same term name in a different sequence level. However, each time you use that same term with different duration values, you use up another resource. In other words, there is no difference in using one resource term four times with different pattern durations than to use all four resource terms once.

Since the timer can operate individually within each sequence level, it is like actually having up to four timers in the total trigger specification. However, if you choose to use a timer, the occurrence counter is not available in that same level. On a per-sequence level basis, the timer/counter is either a timer or a counter, but not both. In addition to the timer/counter, the resource terms are separated into two groups:

- Bit Patterns Terms patt1–patt4
- Edge Terms 1 and 2 (Timing only)



### **Bit Patterns Terms patt1–patt4**

Bit patterns with default names patt1– patt4 are available to use for any of the four resources. Bit pattern resource terms are set to match the numeric value or bit pattern of a group of data channels. All bits of the pattern that are not defined as Don't Cares (x) must match the input data in order for a pattern to be present. Bit patterns can also be used in a negated form ( $\neq$ patt1 –  $\neq$ patt4). All term names can be changed to a customized name that may better suit a measurement.

### **Edge Terms 1 and 2 (Timing only)**

Edge terms with default names edge1 and edge2 are available in the timing acquisition mode. They can be assigned to two of the four resources to identify a rising or falling edge, or either edge. The edge resource is true if any of the defined bit transitions occurs.

### **Timer/Occurrence Counter Term**

Although the timer/counter is not located with the other resource terms, it is still considered a resource term. Because the timer/counter works exclusively for each level it is assigned to, it will not affect any other level of the trigger specification from a global aspect. Either a timer or an occurrence counter may be used in each sequence level, and it can have different values assigned in each level.

## Assigning Resource Term Names and Values

The Terms field identifies the list of available resource term names within the analyzer. The resource term names (patt1 – patt4, edge1, edge2) are default names and can be changed if desired. The pattern and edge terms can also have their values changed bit by bit or all at once with preset values.

### Using Preset Values

When any of the individual term fields (patt1 – patt4, edge1, edge2) are selected, a configuration menu appears. Use this configuration menu to quickly assign the resource term to a preset value, or to assign a customized name to the resource term.

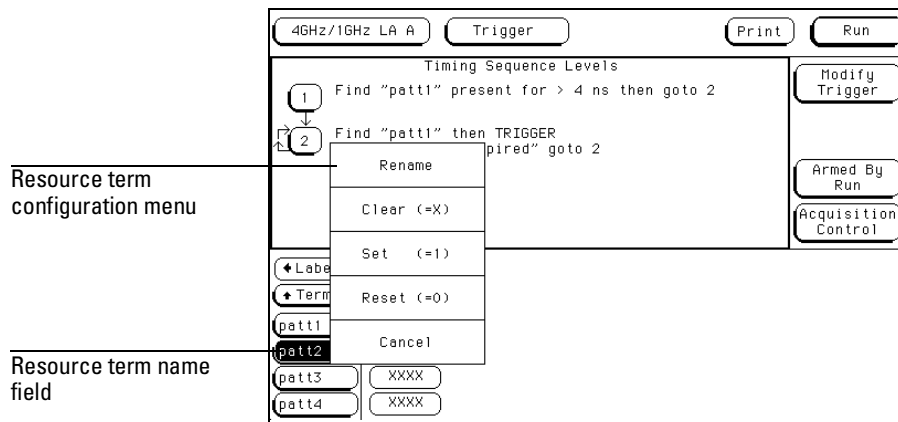

### Resource Term Configuration Menu

**Rename** This function accesses a keypad which you use to create a custom name or edit the existing name for the resource term. This function works for both pattern and edge names.

**Clear (=X)** Sets the term assignment fields as follows:

In terms patt1 – patt4, the assignment field is set to all "X" (don't cares).  
 In terms edge1 – edge2, the assignment field is reset to all "." (periods).

**Set (=1)** Sets the pattern terms to all 1s. Not available for edge terms.

**Reset (=0)** Sets the pattern terms to all 0s. Not available for edge terms.



### Setting Bit Pattern Values

Just to the right of the term name fields are the term assignment fields. When any of the individual assignment fields are selected, a keypad appears. Use this keypad to assign values or Don't Cares (x).

### Edge Terms 1 and 2

If you want to qualify an edge, place the appropriate edge on the data channel you are watching. When the analyzer sees an edge, the term becomes true.

Edge terms can be used singularly or in combination with each other across all assigned channels. When you specify an edge on more than one channel, the analyzer ORs the edges.

The following edge choices are available for each bit:

- Positive edge (↑)
- Negative edge (↓)
- Either positive or negative (↕)
- Not assigned (.)

After the assignment menu closes, you may see "\$" indicators in the assignment field display. This symbol indicates the assignment can't totally be displayed in the selected base. It was assigned in another base. When Binary is selected for the numeric base, you see the actual assignments.

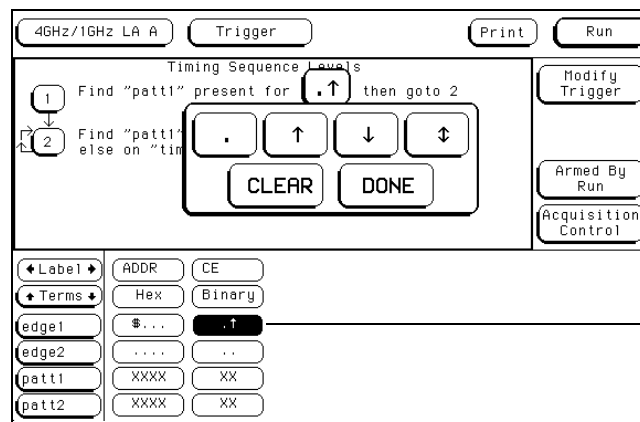

Term assignment field

### Edge Assignment Pop-up Menu

### Timer Term

Timer options are selected from within sequence levels. The timer term is evaluated as either true or false. A true timer term lets the sequence evaluation continue within the current statement. Because the timer works exclusively for each level it is assigned to, it will not affect any other level or the trigger specification from a global respect. However, each sequence level can have its own timer with different values assigned. The timer term options are used in the following ways:

**"Timer expired"** The timer term becomes true when its assigned time expires.

**"Timer not expired"** The timer term is true while the assigned time has not expired. Once expired, the timer term becomes false. This is like negating the timer.

### Combination of Terms

Combination terms are configured and selected from within sequence levels. All user-defined resource terms can be combined to create complex qualifiers that occupy a single assignment field space.

When the term assignment field is selected, and "Combination" is selected from the pop-up selection list, a logical assignment menu appears. Use this menu to select pre-defined resource terms as inputs to a chain of logical operators.

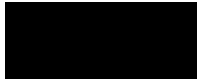

## The Trigger Menu

### Assigning Resource Term Names and Values

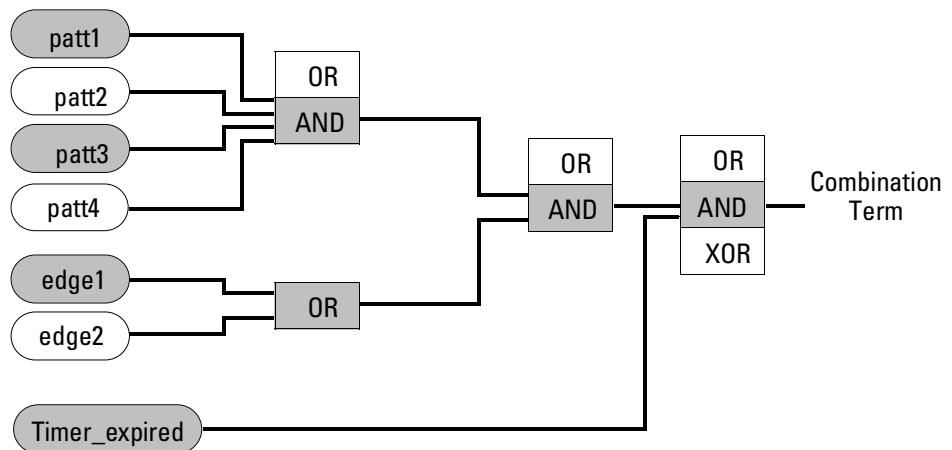

#### Combination Term Choices

Logical operators are configured into the chain by selecting the logical operation field. They will toggle to another choice, or, a selection list will appear.

When the configuration process is complete, and the "Done" field is selected, the created combination of terms is then inserted into the term assignment field in the sequence instruction.

Build the complex term under the following conventions:

- Bit patterns are ORed or ANDeD to other bit patterns.
- Edges are ORed to other edges.
- Bit patterns are ANDeD or ORed to edges.
- Any bit pattern and edge combination is ANDeD, ORed, or XORed to the timer.

When the combination is placed in the assignment field, if the term is too long to fit in the assignment field, the display is truncated.

## Label and Base fields

The Label and Base fields show up together in all menus except the Format menu. When a new label is assigned, a base field is automatically assigned to that label.

**Label Field** Labels are displayed throughout the analyzer as they were assigned in the Format menu. To reorder currently displayed labels in the Trigger menu and the Specify Pattern sub-menus, select the label you want to move, then from the selection menu that appears, choose the label you want to switch positions with.

### See Also

"Labels Assignment" chapter, in the Common Modules Operations section of the *HP 16500/16501A Logic Analysis System User's Reference*.

**Base Field** All assigned labels will have a base field. If the numeric base is changed in a menu, the base in other menus may not change accordingly. As an example, the base assigned to symbols is unique, as is the base assigned in the Compare and Listing menus. The base choices are Binary, Octal, Decimal, Hex, ASCII, Symbol, and Twos.

**Label and Terms roll field** The rolling function is the same for all items that are stored offscreen. For more information on rolling labels, base, and pods, refer to the "Labels Assignment" chapter in the *HP 16500/16501A Logic Analysis System User's Reference*.

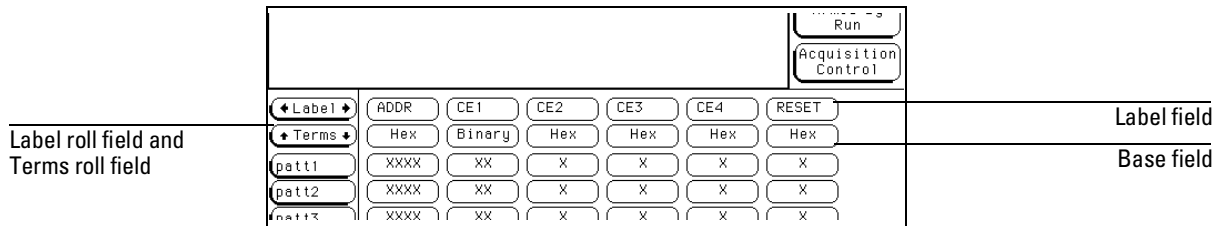

Detail of Trigger Menu

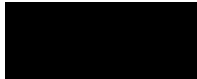

---

# Acquisition Control

The Acquisition Control menu is used to set the acquisition mode, the trigger position within available memory, and the sample period.

## Acquisition Mode Field

The Acquisition Mode field toggles between Manual and Automatic. When set to Automatic, the trigger position and sample period are computed based on the sec/Div and delay settings in the Waveform menu.

When the Acquisition Mode field is set to Manual, additional configuration fields become available. The additional configuration fields work together with the sequence instructions, in a prioritized manner, to position the memory in relation to the trigger point.

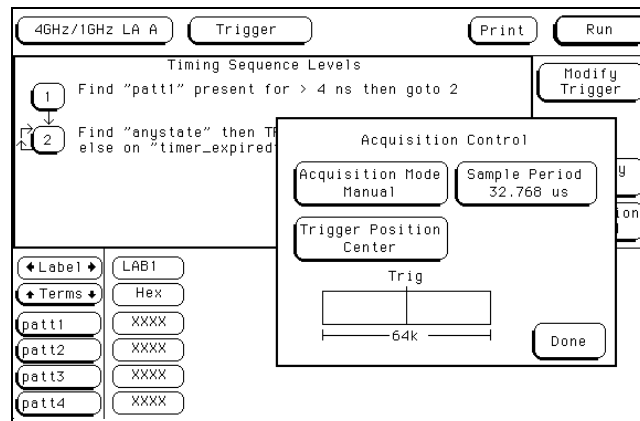

**Acquisition Control Pop-up Menu (Timing Mode)**



---

## Trigger Position Field

The Trigger Position field accesses a selection menu with the options of Start, Center, End, User Defined, or Delay. When an option is selected, that point of the available memory is positioned relative to the trigger. A representation of this is shown by the blue graphic bar with the "Trig" indicator line. The Trigger Position field determines how much data is stored before and after the trigger occurs for all subsequent acquisitions.

When a Run is started, the analyzer will not look for a trigger until at least the proper percent of pretrigger data has been stored. After a trigger has been detected, the proper percent of posttrigger data is stored before the analyzer halts.

Even when the trigger position is set to Start or End, there will always be a small portion of pretrigger and posttrigger data stored.

**Start** When the trigger position is set to Start, the starting point of available memory is positioned relative to the trigger point. This results in maximum posttrigger data and minimum pretrigger data.

**Center** When the trigger position is set to Center, the center point of available memory is positioned relative to the trigger point. This results in half pretrigger data and half posttrigger data.

**End** When the trigger position is set to End, the end point of available memory is positioned relative to the trigger point. This results in maximum pretrigger data and minimum posttrigger data.

**User Defined** When the trigger position is set to User Defined, a Post Store field appears. Use this field to set the trigger position anywhere between 0% and 99%. As the Post Store is adjusted, the blue graphic bar indicates the trigger position.

**Delay** Use the Delay field to delay the start of acquisition storage after the trigger. The range of the delay time is affected by the sample period but could range between 16 ns to 8 ks.



---

## Sample Period Field (Timing only)

The Sample Period field is used to set the time period between data samples. Every time a new sample is taken, the analyzer will see updated measurement data.

In full-channel mode, the sample period is configurable. A list of choices appear when the field is selected. In half-channel mode, the analyzer automatically runs at a 250 ps sample period, and is not adjustable.

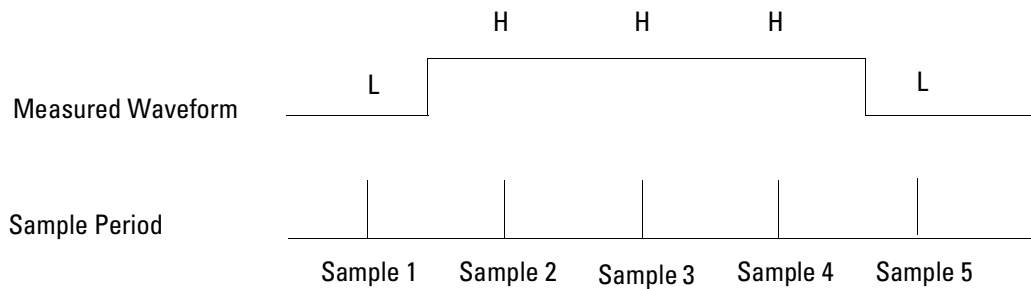

### Sampling

---

## Samples/Clock Field(State only)

The Samples/Clock field sets the number of extra sample points (oversampling) between the external clock edges. All oversampled points are evenly distributed within the period of the external clock. When the data is displayed in the state listing, all sampled points are shown by default.

Oversampling is set in powers of two, up to a maximum of 32, or a sample rate not exceeding 2 GSa/s. The equation below illustrates how the maximum sample rate is limited.

$$(\text{external clock rate}) \times (\text{oversampled setting}) \leq 2 \text{ GHz}$$

The external clock rate is checked at each run. If at any time the rate of oversampling exceeds a 2 GHz rate, a lower Samples/Clock setting is automatically chosen.

If at any time while configuring a measurement you notice some of the higher oversampling rate choices not available, this means those choices would have exceeded the 2 GHz sampling rate when multiplied by the external clock rate. The interface will not make those choices available to you until the external clock rate decreases.

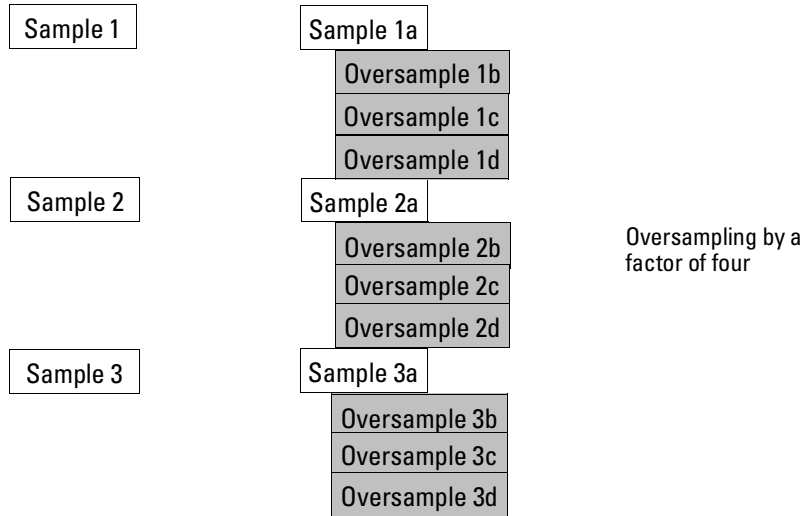

#### Oversampling by 4

Once oversampling is set to a value greater than 1, arrows marking the samples acquired at the specified clock edges appear in the Listing menu. In the Waveform menu, the clocked states are marked with triangular tick marks at the top of the waveform display.

#### See Also

"Show States Field" in the Listing menu chapter for more information on displaying externally clocked states and oversampled states.

#### **The analyzer will not trigger on points of oversampling.**

The only points where the analyzer will trigger are the user's external clock transitions. If triggering is needed on these oversampled points, and the user clock is less than 500 MHz, convert from state mode to timing mode where all triggering is at 500 MHz.

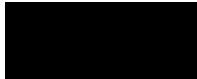

The Trigger Menu  
**Samples/Clock Field(State only)**

The figure below shows data at the external clock transitions, data at the points of oversampling, and the data points where the analyzer could trigger.

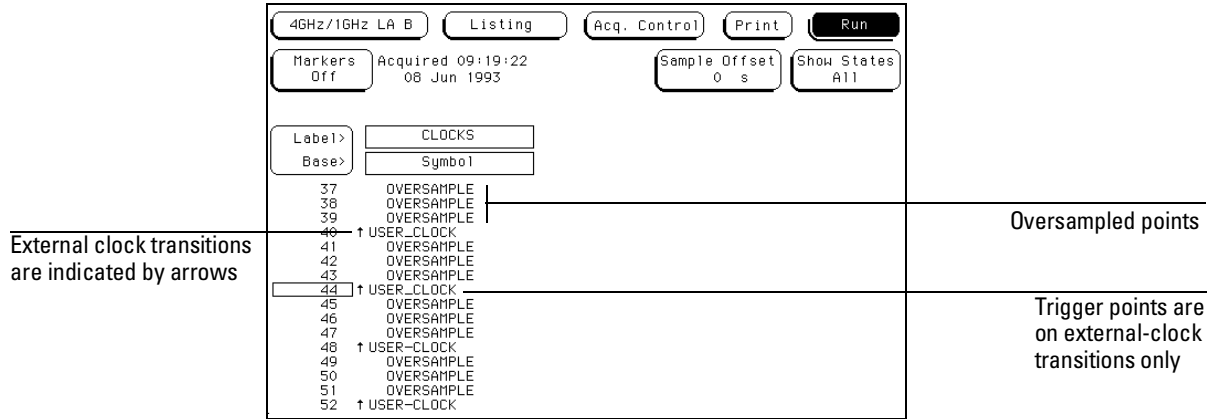

**Trigger Points**

---

## Armed By Field

The logic analyzer can be armed by either the Run field, a Group Run through the Intermodule Bus (IMB), or an external signal through an SMB Port connector on the back panel.

### Run/Group Run

Set the Armed By field to Run if you are using just a single analyzer to make a measurement. When you select the Run/Stop field, you start the trigger evaluation process immediately.

If the measurement includes other modules in the frame, and they are configured as a Group Run in the Intermodule menu, the Run selection becomes a Group Run selection. This type of configuration allows all modules in the measurement to be time-correlated.

### SMB Port

Set the Armed By field to the SMB Port option if you want to arm the analyzer with an external arming signal from an outside source.

An arming signal can also come from another module within the frame, such as an oscilloscope TRIG OUT signal. However, the only way the measurement can be time-correlated is if both the sending and receiving modules are configured as a Group Run in the system's Intermodule menu. Generally, the SMB Port is used when you want an external trigger source to arm a module, or group of modules in the frame, or you want to take advantage of the faster arming path.

### See Also

"Intermodule Measurements" chapter in the *HP 16500B User's Reference* or "Correlating Measurements" chapter in the *HP 16500C User's Reference* for information on making a measurement using other modules through the IMB.

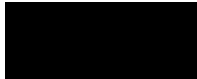





## The Listing Menu

---

# The Listing Menu

The Listing menu is a display menu for the acquired data in either the state or timing acquisition modes. The acquired data is displayed in the order the analyzer placed the data into memory. Data is grouped and displayed by label and in a selectable base.

State listings display data, address, and control status at each clock cycle of an external clock. Timing listings display signal activity captured at selectable speeds of the analyzer's internal clock.

Within the Listing menu, you also have the ability to mark data, and control the amount of pretrigger and posttrigger data stored.

The screenshot shows the Listing Menu interface with the following elements:

- Buttons: 4GHz/1GHz LA C, Listing, Acq. Control, Print, Run
- Markers: Off
- Acquired: 11:08:00, 25 May 1993
- Sample Offset: 50 ps
- Table with columns: Label, DATA\_1, Time, DATA\_2
- Sub-headers: Base, Hex, Absolute, Hex
- Annotations: "Memory locations" points to the Label column, "Data in memory" points to the DATA\_1 column, and "Base" points to the Base sub-header.

Label	DATA_1	Time	DATA_2
Base	Hex	Absolute	Hex
-7	07	-363.9 ns	05
-6	87	-311.9 ns	04
-5	84	-259.9 ns	86
-4	86	-207.9 ns	87
-3	44	-155.9 ns	44
-2	47	-104.0 ns	45
-1	44	-51.98 ns	47
	C7	0 s	C6
1	C4	51.98 ns	C5
2	27	104.0 ns	24
3	27	155.9 ns	25
4	24	207.9 ns	27
5	A7	259.9 ns	A6
6	A4	311.9 ns	A5
7	67	363.9 ns	64
8	67	415.8 ns	65

**The Listing Menu**



## Markers Field

The Markers field may appear in different locations depending on the menu you are in. Regardless of its location, the Markers field is always used to access a marker selection menu.

**See Also**

"Markers and Stop Measurements" chapter found later in this reference for complete information on marker and stop measurement operations.

## Data Roll Field

The column of numbers at the far left represents the location of the acquired data in the analyzer's memory. The numbered positions are also known as the state locations and are relative to the trigger state location.

The data can be rolled to display other data by using the data roll field. The data roll field is the small rectangular box located in the middle of the state location column.

The data roll field is used to either roll the data listing or to select an exact state for display. When the data roll field is light blue, the knob is active and can roll data in either direction. If you select the data roll field when it is light blue, a pop-up keypad appears for the number of an exact state. When the pop-up keypad is used, the data listing shifts, leaving the selected state in the light blue data roll box.

Data roll field

The screenshot shows the Listing Menu interface with several control buttons at the top: 4GHz/1GHz LA C, Listing, Acq. Control, Print, and Run. Below these are status indicators: Markers Off, Acquired 11:08:00 25 May 1993, and Sample Offset 50 ps. The main data table has columns for Label, Base, DATA\_1 (Hex), Time (Absolute), and DATA\_2 (Hex). A list of data points is shown, with the row for state '1' highlighted in light blue. A small rectangular box, the data roll field, is positioned over the state number '1' in the first column.

Label>	DATA_1	Time	DATA_2
Base>	Hex	Absolute	Hex
-7 ↑	07	-363.9 ns	05
-6 ↑	87	-311.9 ns	04
-5 ↑	84	-259.9 ns	86
-4 ↑	86	-207.9 ns	87
-3 ↑	44	-155.9 ns	44
-2 ↑	47	-104.0 ns	45
-1 ↑	44	-51.98 ns	47
1 ↑	C7	0 s	C6
2 ↑	C4	51.98 ns	C5
3 ↑	27	104.0 ns	24
4 ↑	27	155.9 ns	25
5 ↑	24	207.9 ns	27
6 ↑	A7	259.9 ns	A6
7 ↑	A4	311.9 ns	A5
8 ↑	67	363.9 ns	64
8 ↑	67	415.8 ns	65

**Listing Menu with Data Roll Field**



## Label and Base Fields

The Label and Base fields show up together in all menus except the Format and Configuration menus. When a new label is assigned, a base field is automatically assigned to that label.

**Label Field** Labels in the Listing menu are the same labels assigned in the Format menu. Labels assigned in the Format menu are displayed throughout the analyzer as they were assigned in the Format menu. To add, delete, or reorder the pre-assigned labels, select the label you want to modify, then select the desired modify function. From the label selection list that appears, choose the label you want to modify.

**Base Field** All labels have a base field assigned. If the numeric base is changed in a menu, the base in other menus may not change accordingly. For example, the base assigned to symbols is unique, as is the base assigned in the Compare and Listing menus.

The base is changed by selecting the Base field under the desired label, then selecting the new base from a selection menu. The base choices are Binary, Octal, Decimal, Hex, ASCII, Symbol and Twos.

Label>	DATA_1	Time	DATA_2	
Base>	Hex	Absolute	Hex	
-7 ↑	07	-363.9 ns	05	Label field
-6 ↑	87	-311.9 ns	04	Label field
-5 ↑	84	-259.9 ns	86	Label field
-4 ↑	86	-207.9 ns	87	Label field
-3 ↑	44	-155.9 ns	44	Label field
-2 ↑	47	-104.0 ns	45	Label field
-1 ↑	44	-51.98 ns	47	Label field
1 ↑	C7	0 s	C6	Base field
2 ↑	C4	51.96 ns	C5	Base field
3 ↑	27	104.0 ns	24	Base field
4 ↑	27	155.9 ns	25	Base field
4 ↑	24	207.9 ns	27	Base field
5 ↑	A7	259.9 ns	A6	Base field
6 ↑	A4	311.9 ns	A5	Base field
7 ↑	67	363.9 ns	64	Base field
8 ↑	67	415.8 ns	65	Base field

### Label and Base Fields

## Show States All/Ext Clock (State only)

The Show States field only appears in the state acquisition mode and only when an oversampling value is set. The field toggles between All and Ext Clk.

**See Also**

"Samples/Clocks Field" in the Trigger menu for information about oversampling.

**All** The All selection displays both the externally clocked states and the oversampled states. All externally clocked states are marked in the Listing menu with arrows representing the specified clock edge. In the Waveform menu, the clock states are marked with triangular tick marks at the top of the waveform display.

**Ext Clk** The Ext Clk (external clock) selection displays only the externally clocked states. Externally clocked states are those you would have acquired without oversampling.



The screenshot shows the Listing menu interface. At the top, there are buttons for "4GHz/1GHz LA B", "Listing", "Acq. Control", "Print", and "Run". Below these are fields for "Markers Off", "Acquired 09:19:22 08 Jun 1993", "Sample Offset 0 s", and "Show States All". A label "Show states field" points to the "Show States All" field. Below the acquisition information is a table with columns "Label>" and "Base>". The table lists clock states from 37 to 52. States 37-39 are "OVERSAMPLE", state 40 is "USER\_CLOCK" with an arrow, states 41-43 are "OVERSAMPLE", state 44 is "USER\_CLOCK" with an arrow, states 45-47 are "OVERSAMPLE", state 48 is "USER\_CLOCK" with an arrow, states 49-51 are "OVERSAMPLE", and state 52 is "USER\_CLOCK" with an arrow. A label "Arrow indicator for external clock" points to the arrow next to state 40.

Label>	Base>
37	OVERSAMPLE
38	OVERSAMPLE
39	OVERSAMPLE
40	↑ USER_CLOCK
41	OVERSAMPLE
42	OVERSAMPLE
43	OVERSAMPLE
44	↑ USER_CLOCK
45	OVERSAMPLE
46	OVERSAMPLE
47	OVERSAMPLE
48	↑ USER_CLOCK
49	OVERSAMPLE
50	OVERSAMPLE
51	OVERSAMPLE
52	↑ USER_CLOCK

Show States Field

---

## Sample Offset Field (State only)

The Sample Offset field only appears in the state acquisition mode, and when the markers are turned off. Use it to offset the sample clock with respect to the external clock edge. The Sample Offset field moves the sample point closer to the start point of valid data.

**See Also** "Set Sample Offset Field" in the Format Menu chapter.

---

## Specify Patterns Field

The Specify Patterns field only appears when the Pattern markers are turned on. For complete information on the function of the Specify Patterns field, refer to "Specify Patterns Field" in the Markers and Stop Measurements chapter found later in this reference.

**See Also** "Specify Patterns Field" in the Markers and Stop Measurements chapter.

---

## Acquisition Control Field

**See Also** For complete information on the function of the Acquisition Control, refer to "Acquisition Control" section in the Trigger menu.



---

## The Waveform Menu

---

## The Waveform Menu

The Waveform menu is one of the analyzer display menus. You use the Waveform menu to view data captured in either state or timing acquisition modes and in a format similar to an oscilloscope display. Data is displayed with the horizontal axis representing time, and the vertical axis representing logic highs and lows. The analyzer displays the data in reference to the trigger point.

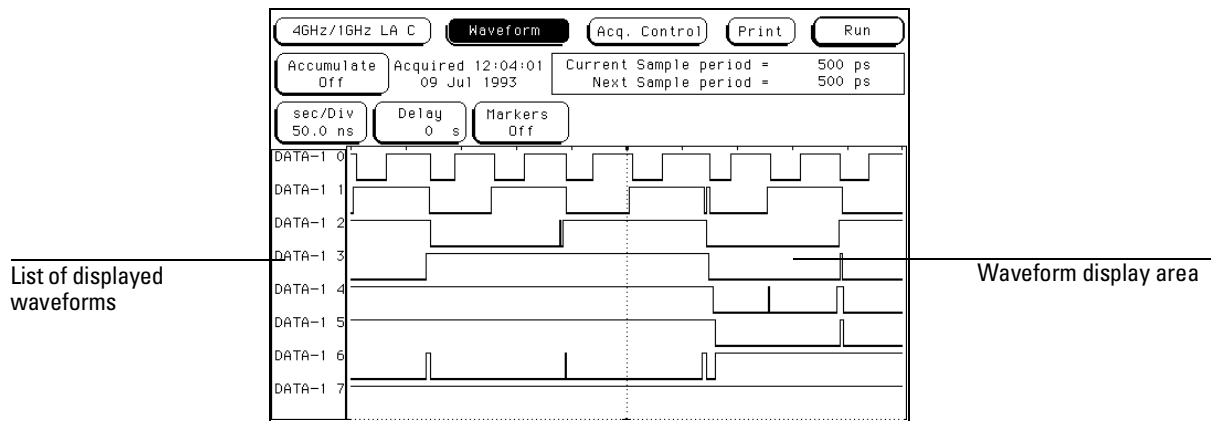

**The Waveform Menu**

---

## Acquisition Control Field

The function of the Acquisition Control field in the Waveform menu is the same as in the Trigger menu.

**See Also**

The "Acquisition Control Field" in the Trigger menu for complete details.

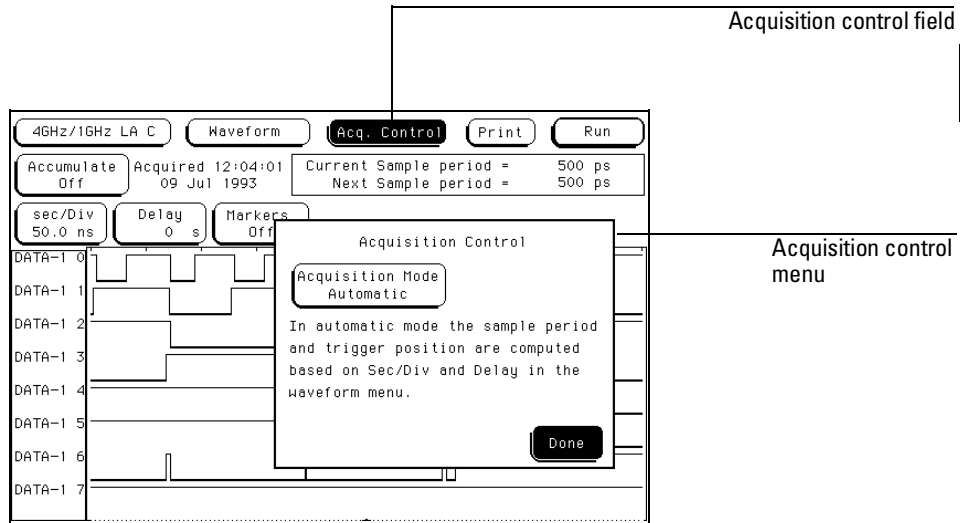

**Acquisition Control Field**

---

## Accumulate Field

The Accumulate field controls whether old data is cleared or displayed with new data. The Accumulate field will toggle On/Off. When Accumulate is on, the analyzer displays the data from a current acquisition on top of the previously acquired data.

The time at which the old data is cleared depends on whether the analyzer is run in Single or Repetitive mode. In Single mode, new data will be displayed on top of the old each time the Run field is selected. In Repetitive mode, data is cleared from the screen only when you start a run after stopping an acquisition with the Stop field.

If you leave the Waveform menu, or pop up a menu over the waveform display, any accumulated display data is lost and the accumulation process starts over.

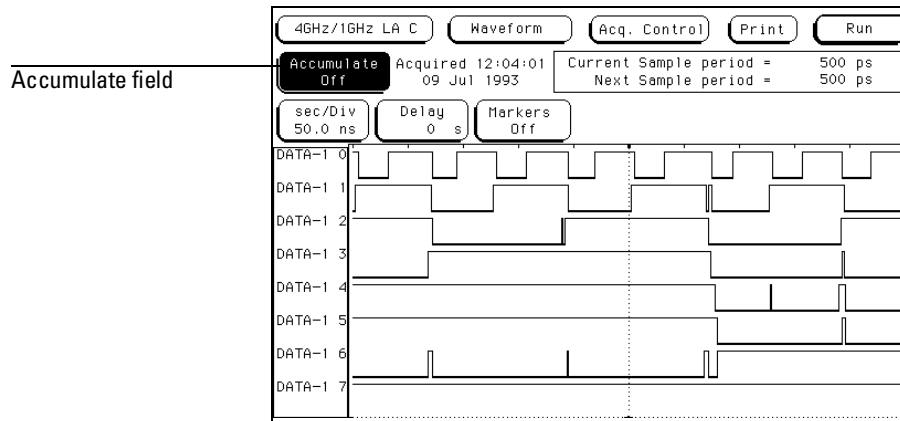

**Accumulate Field**



---

## Seconds Per Division Field

Use the sec/Div field to select the seconds per division resolution. The range of the sec/Div field is 250 ps/Div to 50 s/Div. You set the sec/Div field by either selecting the sec/Div field and rotating the knob, or by selecting the sec/Div field twice, and then using the pop-up keypad. When using the knob to set the sec/Div, the value will change in a 1-2-5 sequence. By adjusting the sec/Div, you can zoom in to view a desired part of the display.

Seconds per division field

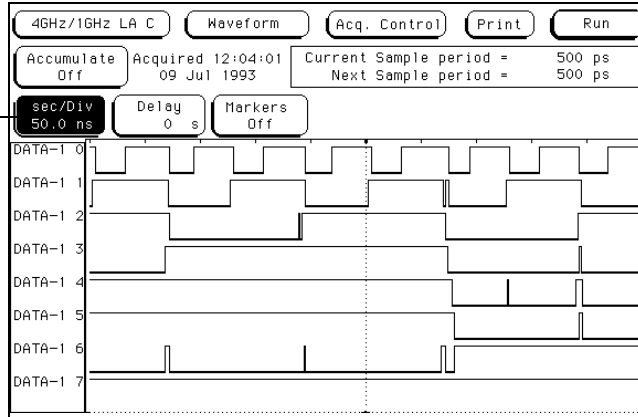

**Seconds Per Division Field**

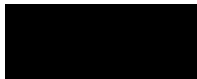

---

## Delay Field

The Delay field allows you to scroll the data and place the desired section at center screen. Changing the delay will not effect the data acquisition unless it is a timing analyzer and the acquisition mode is Automatic mode. The delay range of a timing display is from -2500 seconds to + 2500 seconds.

If you want to move the display window to view data located offscreen to the right, enter a positive delay. If you want to move the display window to view data located offscreen to the left, enter a negative delay.

You can enter a delay using the knob by selecting the Delay field once, which turns it light blue, then turning the knob. If you select the Delay field a second time when it is light blue, a pop-up keypad appears, which enables you to enter an exact number.

### See Also

The "Acquisition Control Field" in the Trigger menu for more information on the effects of delay in the Automatic mode.

Delay field

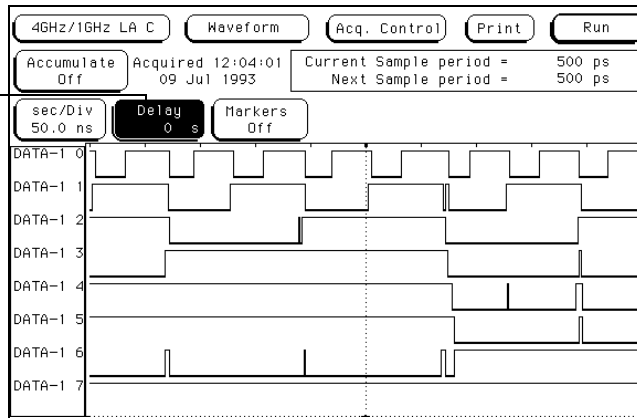

### Delay Field

---

## Sample Period Display (Timing only) External Clock Period Display (State only)

The Sample period display only appears in the timing acquisition mode. A sample period is the interval of time between new data samples. Every time a new acquisition is taken, the analyzer updates the measurement.

The Current Sample period display is the sample period used for the last acquisition. The Next Sample period is the new sample period to be used at the next acquisition. If the acquisition mode is set to automatic, changing the sec/div or delay will affect the sample period.

Both of these display fields are hidden when markers are turned on.

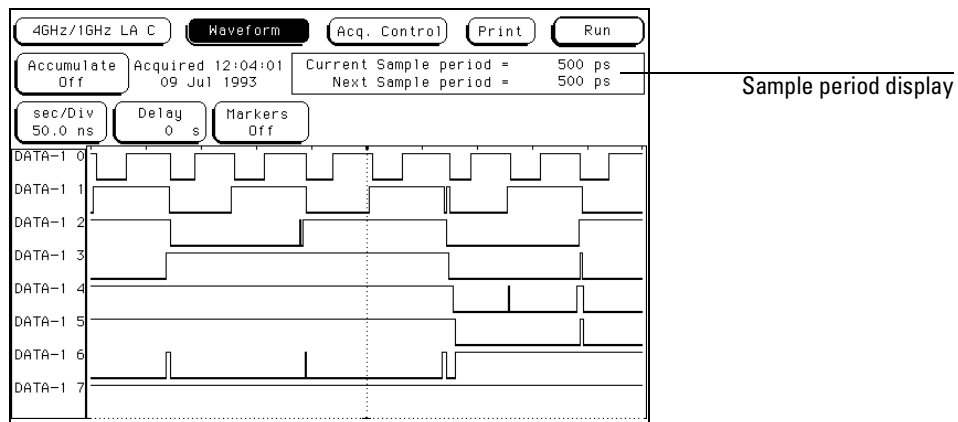

### Sample Period Display

Timing waveforms are reconstructed relevant to the sample period. The shorter sample period puts more sample points on the waveform for a more accurate reconstruction but also fills memory quicker.

If the sec/Div is changed resulting in a change in the next sample period, you must run the analyzer again before the current sample period display is updated.

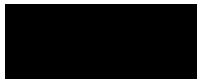

## The Waveform Menu Markers Field

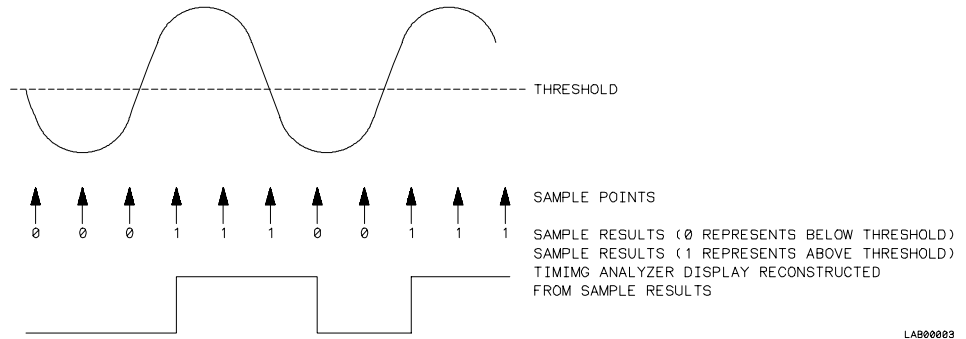

### Sample Points

The External Clock Period display only appears in the state acquisition mode. The clock period display shows the speed of the clock from the target system. Also displayed is the Samples/External Clock which shows how many samples are taken per external clock cycle.

#### See Also

"Samples/Clock Field" in the Acquisition Control section of the Trigger menu for more information on the use of the Samples/Clock field to set oversampling in the state acquisition mode.

---

## Markers Field

The Markers field may appear in different locations depending on the menu you are in. Regardless of its location, the Markers field is always used to access a marker selection menu.

#### See Also

"Markers and Stop Measurements" chapter found later in this reference for complete information on marker and stop measurement operations.

---

## Waveform Display

The waveform display area of the Waveform menu shows state and timing waveforms for labels assigned in the Format menu. It can also combine and display waveforms from other measurement modules when all modules are configured in a Group Run.

### See Also

"Intermodule Measurements" chapter in the *HP 16500B Logic Analysis System User's Reference* or "Correlating Measurements" in the *HP 16500C Logic Analysis System User's Reference* for more information on mixed displays and Group Run.

The waveform display area also accesses the fields used to select, delete, or modify waveforms. The function of selecting waveforms for display, and modifying or deleting waveforms is identical in both state and timing acquisition modes.

Only analyzer waveforms which have bits assigned in the Format menu can be displayed. Each waveform is a member of a set of waveforms grouped under a label. The assigned label name in the Format menu is the name that appears in the Labels selection list.

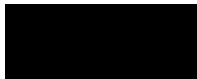

---

## Display Location Reference Line

At the bottom of the Waveform menu is a reference line that displays the relative location of the display window with reference to the total memory. Total memory is represented by a horizontal dotted line. The display window is represented by the overlaid solid line.

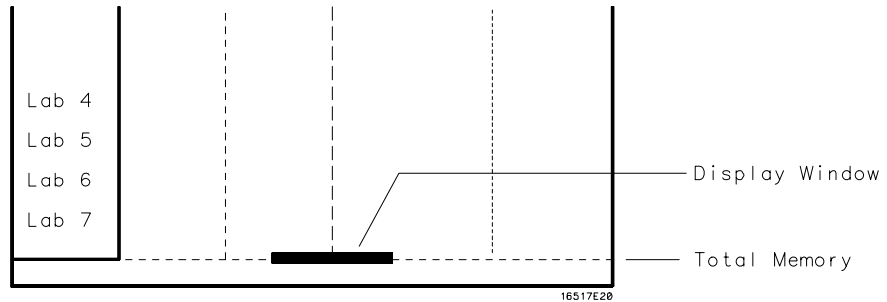

### Display Location Reference Line

---

## External-Clock Indicators (State only)

When oversampling has an assigned value greater than 1, tick marks are displayed at the top of the display showing where the external-clock transitions occur in reference to the displayed waveforms.

**See Also**

"Samples/Clock Field" in the Trigger Menu chapter for information on oversampling.

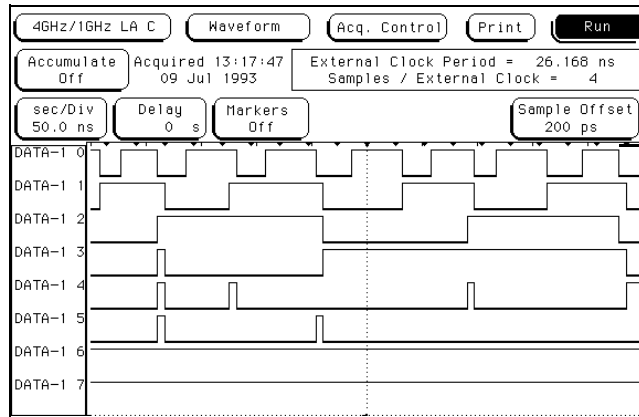

External-clock indicators

**External Clock Indicators**

---

## Blue Bar Field

The blue bar on the left side of the waveform display is both a display and configuration field. After all desired waveforms are configured for display, they are listed in the blue bar. If there are more waveforms than can be displayed, the list is scrolled by selecting the dark blue bar. It then turns light blue, and the knob is then used to scroll. If the blue bar is already light blue, just turn the knob.

If the blue bar is selected when it is light blue, the Waveform Selection menu appears. Use this menu to configure the waveform display.

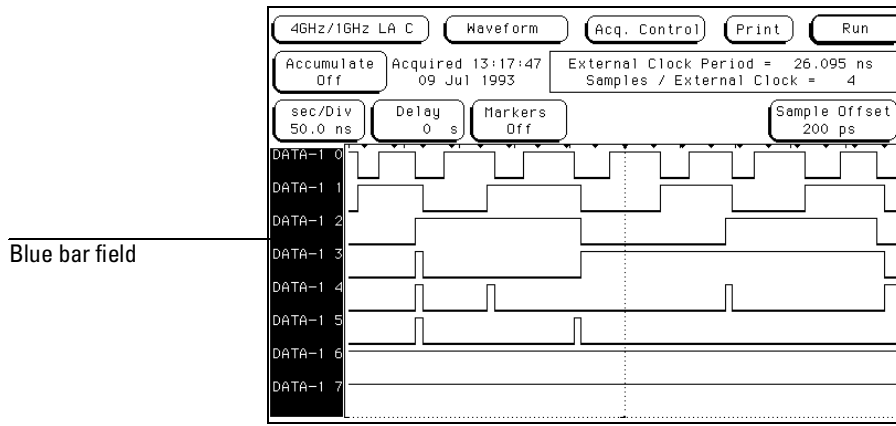

### Blue Bar Field



When the Waveform Selection pop-up menu appears, you select which waveforms are displayed, replaced, or modified. You can display up to 24 waveforms on screen at one time.

Single waveforms or all waveforms under a label can be displayed or turned off. How the waveform bits are assigned for display depends on what Channel Mode is currently selected.

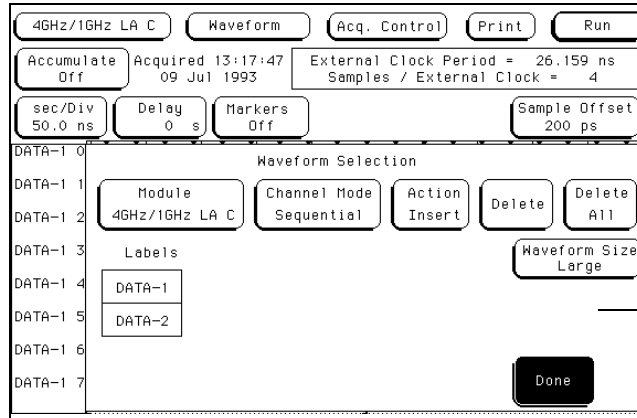

Waveform selection menu

**Waveform Selection Menu**

---

## Channel Mode Field

The Channel Mode field selects which method is used to insert the waveform labels into the display. All inserted labels are placed below the cursor in the blue bar field. When the Channel Mode field is selected, a selection menu appears with the choices below.

### Sequential

The Sequential mode inserts all channels from the selected label, in order, starting below the white cursor.

### Individual

The Individual mode inserts selected channels from a label's channel selection list. The channel selection list appears when a label name is selected. Channels are inserted starting below the white cursor.

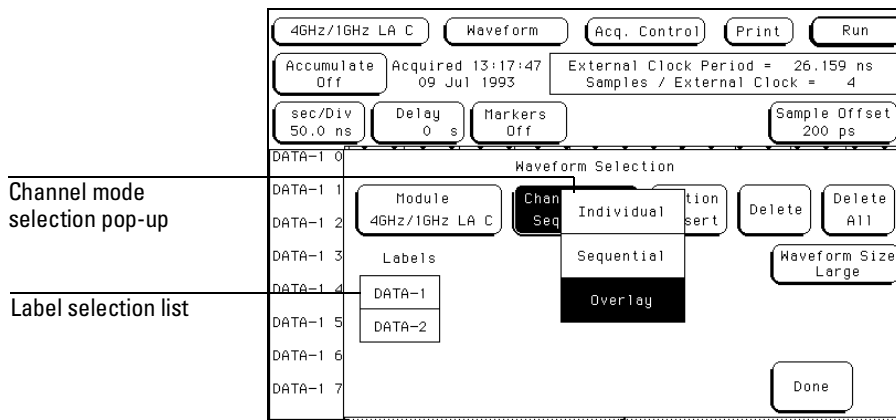

### Channel Mode Selection Menu

**Overlay**

The Overlay mode inserts all bits of a label in a single waveform to form a composite waveform label. The onscreen indication for the Overlay mode is "All" following the label name.

**Viewing State Data in Overlay Mode**

When all assigned waveforms in a label are overlaid, the value of the data is displayed to the right of each new transition in the waveform display.

If the sec/Div is set to view a large increment of time, or if the waveform size is set to Small or Medium, the state data readout will not fit between transitions. To display the data readouts within the waveform, expand the sec/Div and use the Large waveform setting. If symbols are assigned to represent data values, the symbol is displayed.

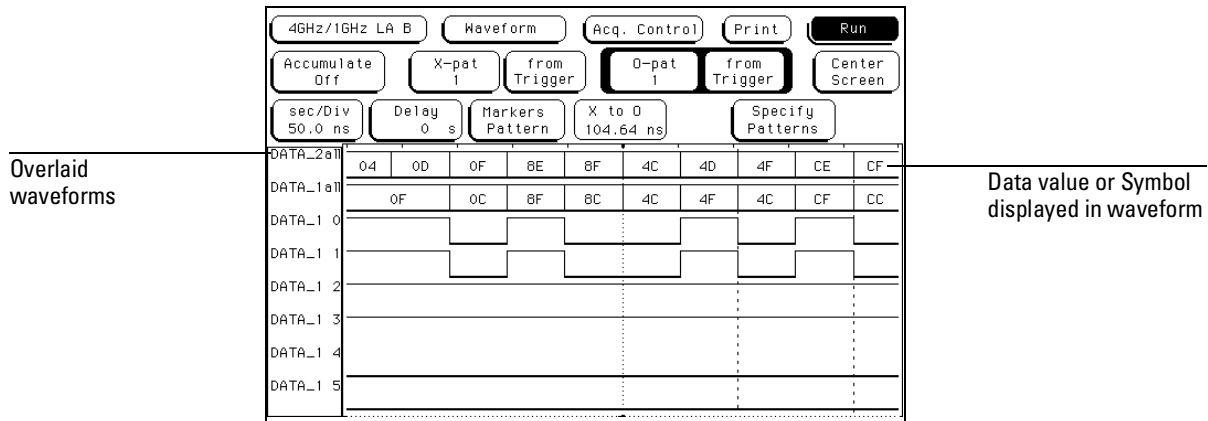

**State Data or Symbols In Overlaid Waveform**

---

## Module and Label Fields

If there are multiple analyzers or oscilloscope modules installed in the mainframe, waveforms from the other modules can be displayed in the waveform menu. The Module field accesses a selection list that contains the modules installed in the mainframe, that are configured in a Group Run, and have timing or oscilloscope waveforms.

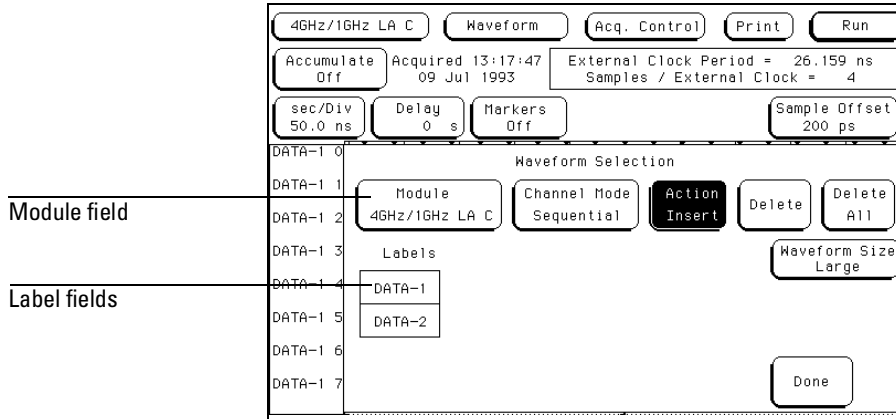

**Module and Label Fields**

---

## Action Insert/Replace Field

The Action field determines if a label or channel is inserted into the display or replaces another label or channel. Insert will append the selected label or channel to the position of the cursor. Up to 96 waveforms can be displayed at a time.

To replace one waveform with another, position the cursor with the knob on the waveform you wish to replace. Touch the Action Insert field to toggle it to Action Replace. Then select the label that will replace the old label.

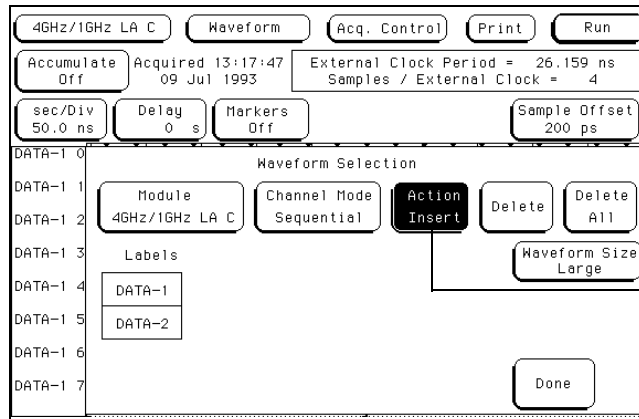

Action insert and replace field

### Action Insert/Replace Field

---

## Delete and Delete All Fields

The Delete field is used to delete single channels within the group of displayed waveforms. To delete any single channel, you first highlight the desired channel by placing the cursor on the channel, then select the Delete field.

You can delete all currently displayed waveforms by selecting Delete All, then by selecting Continue.

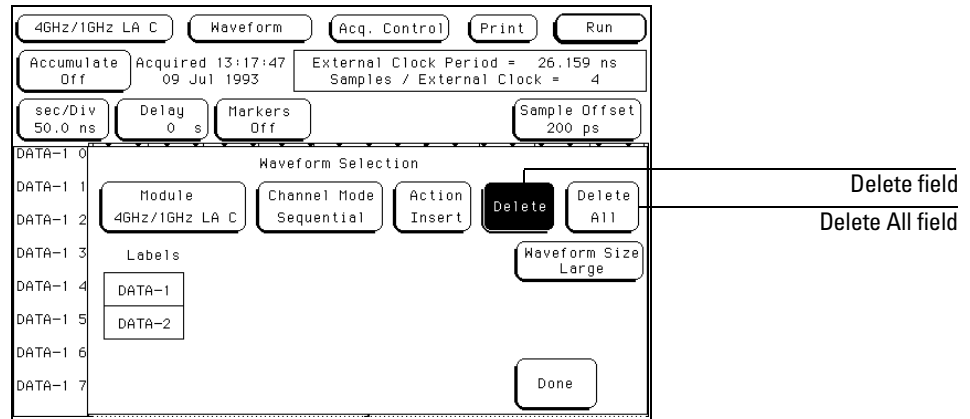

### Delete/Delete All Field

---

## Waveform Size Field

The Waveform Size field accesses a selection menu which contains choices that scale the displayed waveforms to different sizes. A different waveform size can increase the number of waveforms in the display or can make the viewing better for just a few.

### Best Fit

When Best Fit is used, the analyzer picks the largest size, either small, medium, or large, that allows the most waveforms to be displayed.

### Small

Small allows up to 24 waveforms to be displayed.

### Medium

Medium allows up to 16 waveforms to be displayed.

### Large

Large allows up to 8 waveforms to be displayed.

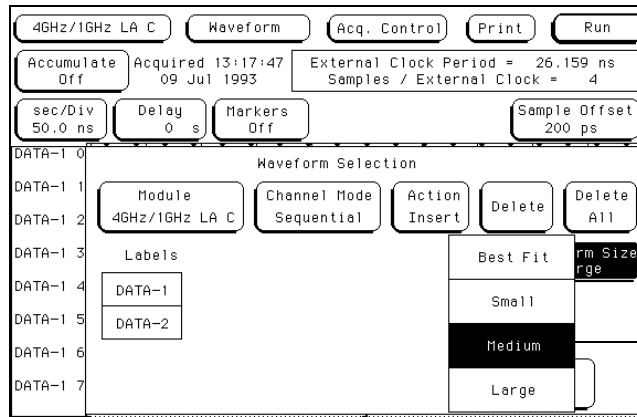

### Waveform Size Selection Menu



---

## Sample Offset Field (State only)

The Sample Offset field only appears in the state acquisition mode, and when the markers are turned off. Use it to offset the sample clock with respect to the external clock edge. The Sample Offset field moves the sample point relative to the clock edge.

**See Also**

"Set Sample Offset Field" in the Format menu chapter for complete information on the function of the Sample Offset field.

---

## Reset Statistics Field

The Reset Statistics field only appears when using Statistics Markers. It is used to clear all statistics, and reset them to zeros.





## The Compare Menu

---

## The Compare Menu

Compare is a software post-processing feature that provides the ability to do a bit-by-bit comparison between the acquired data listing and a reference listing.

The comparison between the acquired listing data and the data in the reference listing is done relative to the trigger points. This means that the two data records are aligned at the trigger points and then compared bit by bit.

Any bits in the acquired data that do not match the bits in the compare image, and are not masked, are treated as unequal.

### **Compare Post-Processing Features**

You can view the acquired data, your reference listing, and a listing that highlights the bits that do not match the bits in the reference listing in separate listings. You can edit the reference listing for unique comparisons.

You can mask specific bits that you do not want to compare. These "Don't compare" bits can be specified individually for a given label and state row, or can be specified by channel across all state rows.

You can select a range of states to compare. When a range is selected, only the bits in states on or between the specified boundaries are compared. Also, you can save the reference listing along with the analyzer configuration to disk.



---

## Reference Listing Field

The Reference listing/Difference listing field is a toggle field that switches the listing type between the Reference image listing and the Difference listing.

The Reference listing is a display of the image (also known as a template) that acquired data is compared to. The boundaries of the image (or size of the template) are controlled by using the channel masking and compare range functions. Any bits in the reference listing displayed as "X" have been set to don't care bits during bit editing.

When the data listing is rolled, the difference data listing and the Listing menu are also rolled.

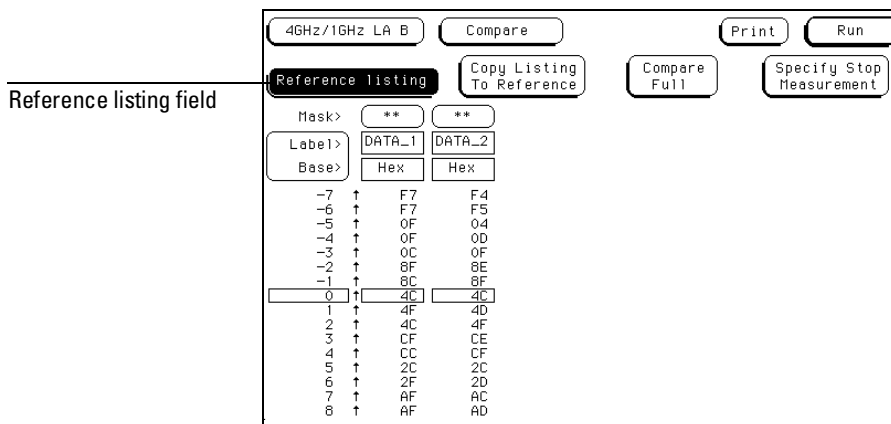

### Reference Listing Field

---

## Difference Listing Field

The Reference listing/Difference listing field is a toggle field that switches the listing type between the Reference image listing and the Difference listing.

The Difference listing is a display of the acquired data listing. Data that is different from the Reference listing is highlighted with inverse video. If the base is Symbols, the entire line is highlighted in inverse video.

Difference listing field

The screenshot shows a control panel with the following elements:

- Buttons: 4GHz/1GHz LA B, Compare, Print, Run
- Field: Difference listing (highlighted)
- Buttons: Find Error 0, Compare Full, Specify Stop Measurement
- Mask: \*\*
- Label: DATA\_1, DATA\_2
- Base: Hex, Hex
- Data listing (lines 4-19):

Line	DATA_1	DATA_2
4	CC	CF
5	2C	2C
6	2F	2D
7	AF	AC
8	AF	AD
9	6F	6C
10	6F	6D
11	EF	EC
12	EF	ED
13	1F	1C
14	1F	1D
15	1C	1F
16	9F	9E
17	9C	9F
18	5C	5C
19	5F	5D

**Difference Listing Field**

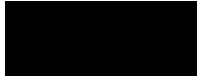

## The Compare Menu

### Difference Listing Field

The controls that roll the listing in all three menus — the normal state listing, the Reference listing, and the Difference listing — are synchronized, unless the number of pretrigger states differs between the Reference listing and the acquired data.

This synchronization means that when you change the current row position in the Difference listing, the analyzer automatically updates the current row in the acquired State listing and Reference listing, and vice-versa.

If the three listings are synchronized and you reacquire data, the Reference listing may have a different number of pretrigger states depending on the trigger criteria. The Reference listing can be resynchronized to the State and Difference listings by entering the desired state (acquisition memory) location from the pop-up keypad.

The cross-functional synchronization allows you to view corresponding areas of all lists, to cross check the alignment, and to analyze the bits that do not match.

---

## Copy Listing to Reference Field

The initial Reference image is generated either by copying the data listing from the Listing menu or by loading an analyzer configuration file which contains a Reference listing. If you load an analyzer configuration to get a Reference image, the other menu setups will change.

When the Copy Listing to Reference field is selected, the contents of the acquisition data structure (Listing menu display) are copied to the Reference image buffer. The previous Reference image is lost if it has not been saved to a disk.

Copy listing to  
reference field

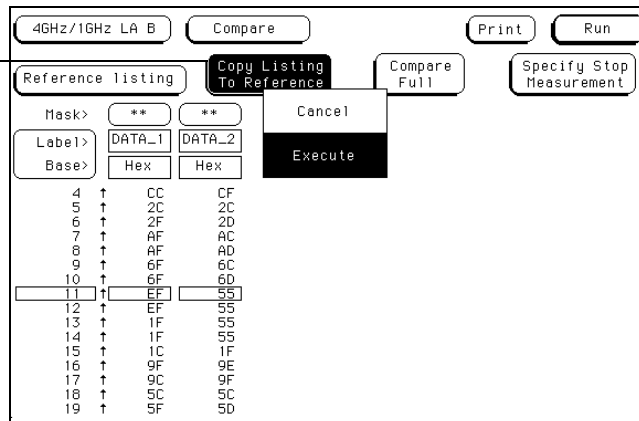

Copy Listing to Reference Field

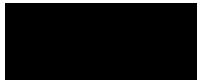

---

## Find Error Field

The Find Error field allows you to easily locate any data that did not match in the last comparison. Occurrences of differences, or errors, are found in numerical ascending order from the start of the listing. The first occurrence of an error has the numerical value of one.

When you select the Find Error field, the field turns light blue and the knob can be used to scroll from one error to another, skipping states that match the reference listing. If the field is touched a second time, a pop-up keypad appears in which you enter a number. The number you enter indicates which error you want to find. The listing is then scanned sequentially until the specified occurrence is found and rolled into view.

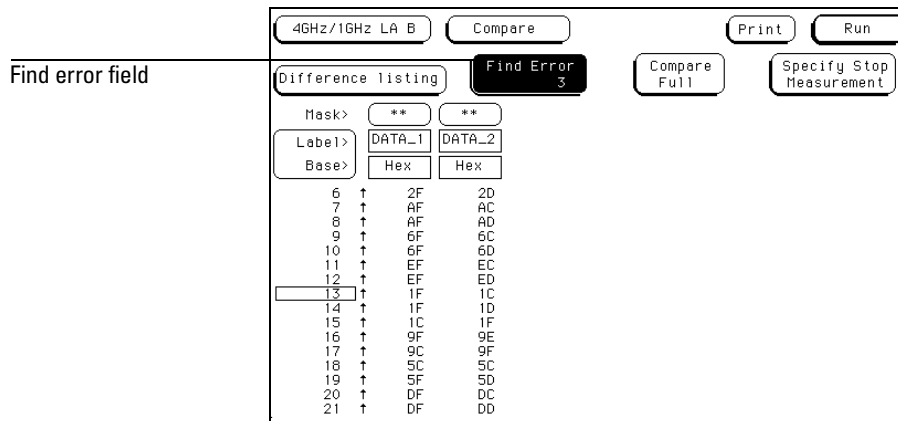

### Find Error Field



---

## Compare Full / Compare Partial Field

The Compare Full/Compare Partial field is a toggle field that allows you to compare either the full range of states or define a subset of the total number of states in the Reference image for use in the comparison.

The Compare mode is accessed by touching the Compare Full/Compare Partial field in either the Compare or Difference listing menus. When selected, a pop-up menu appears in which you select either the Full or Partial option.

When you select the Partial option, fields appear for setting the start state and stop state values. Only bits in states (lines) on or between the boundaries are compared against the acquired data.

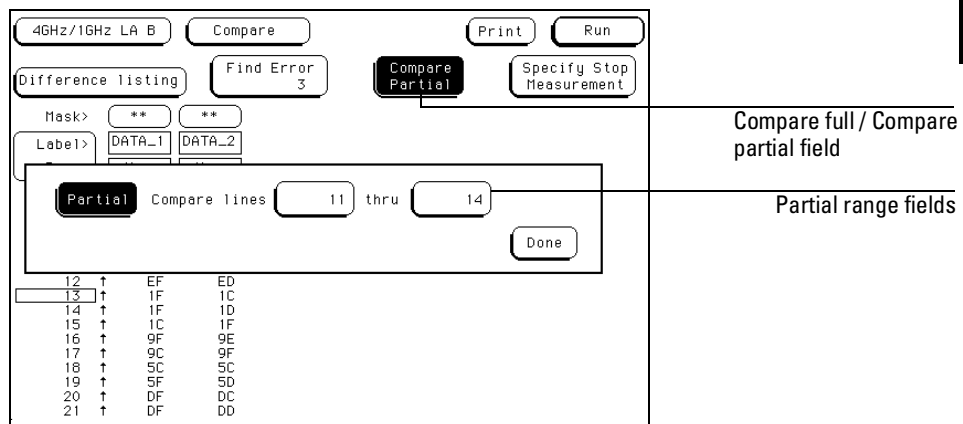

**Compare Full / Compare Partial Field**

---

## Mask Field

The channel masking field is used to specify the bits in each label that you do not want compared. This causes the corresponding bits in all states to be ignored in the comparison. The Reference data image itself remains unchanged on the display.

When you select the Mask field an assignment pop-up appears in which you specify which channels are to be compared and which channels are to be masked. A "." (period) indicates a don't compare mask for that channel and an "\*" (asterisk) indicates that channel is to be compared.

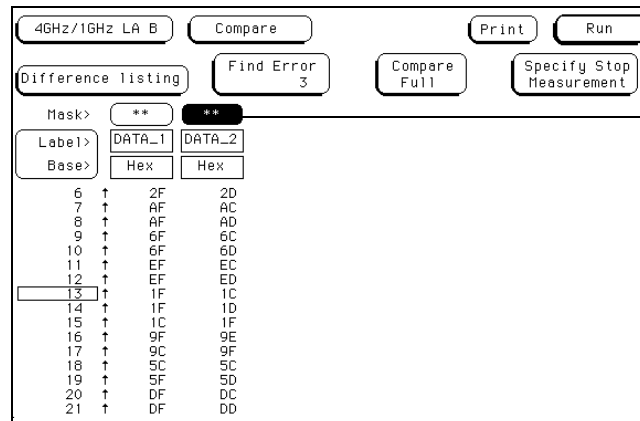

Mask field

### Mask Field

## Specify Stop Measurement Field

The Stop Measurement function allows you to specify a condition which stops the analyzer measurement during a repetitive run. When the Specify Stop Measurement field is selected, a Stop Measurement menu appears which is used to set the stop criteria.

When the Stop Measurement type field is selected, a selection menu appears. Depending on the analyzer configuration, you will have the choices of Off, Compare, and X-O.

### Off

The Off selection turns all Stop measurement operations off.

If the stop measurement operation is not turned off and the stop measurement criteria are met, the measurement will stop even though the markers are turned off.

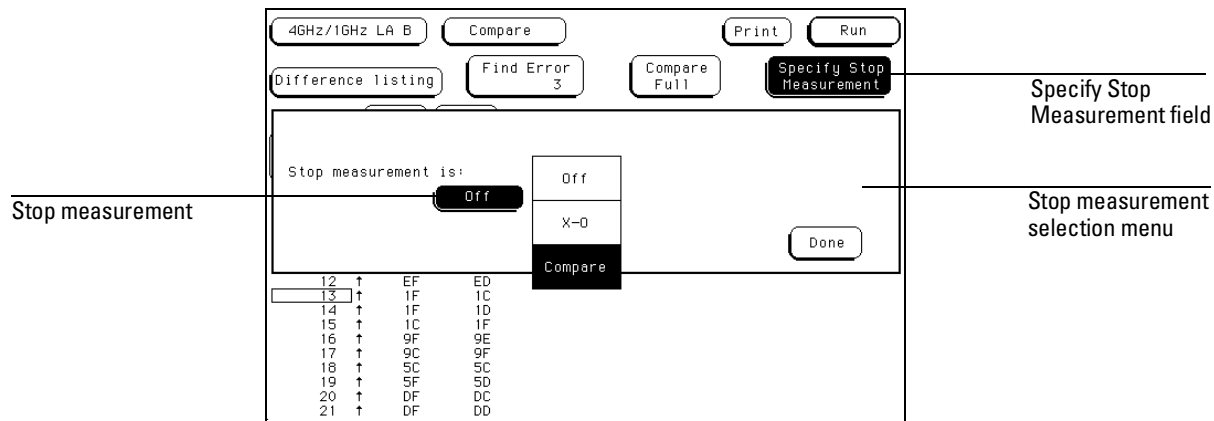

### Stop Measurement Fields

## The Compare Menu Specify Stop Measurement Field

### Compare

When Compare is selected, a repetitive run is stopped when a comparison of data in the Listing menu and data and criteria in a Reference image matches an Equal/Not Equal selection. The equality selection is set from the Equal/Not Equal selection pop-up menu.

**Equal** The data and mask criteria in the Compare menu must be equal to the data in the Listing menu.

**Not Equal** The data and mask criteria in the Compare menu must not be equal to the data in the Listing menu.

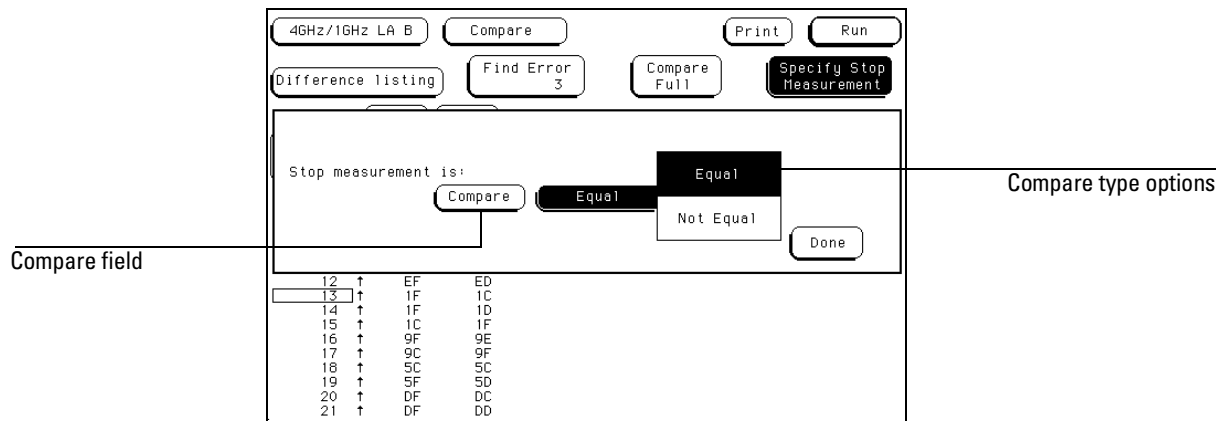

### Compare Stop Measurement Type Fields

### X-O

When X-O is selected, a repetitive run is stopped when a comparison of the time period between the X and O pattern markers and one of the following time period options is true.

**Less Than** X-O time must be less than the time value that you specify in the Time field.

**Greater Than** X-O time must be greater than the time value that you specify in the Time field.

**In Range** X-O time must be within the time range value that you specify in the two Time fields.

**Not in Range** X-O time must not be within the time range value that you specify in the two Time fields.

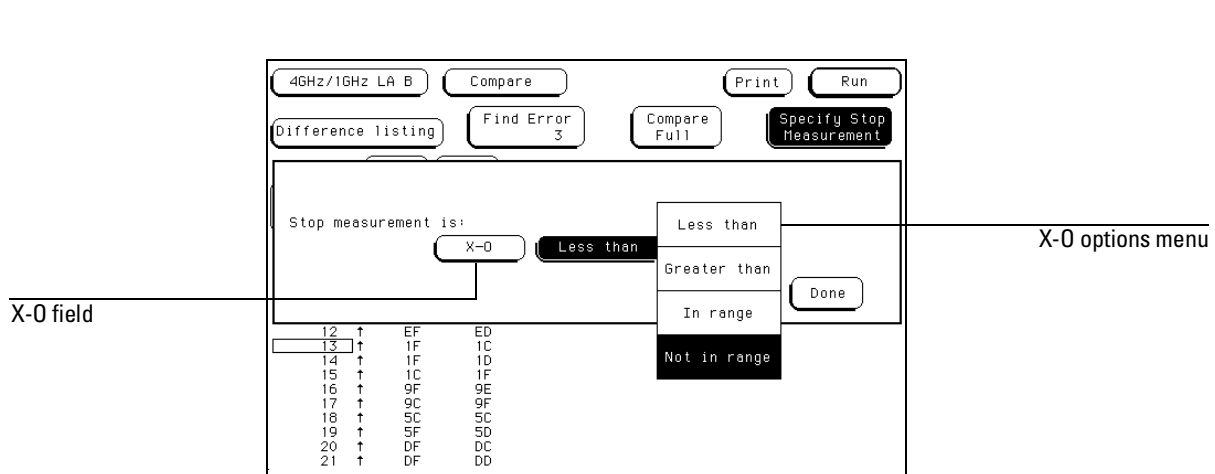

### X-O Stop Measurement Type Fields

---

## Data Roll Field

The column of numbers at the far left represents the location of the acquired data in the state analyzer's memory. The numbered positions are also known as the state locations and are relative to the trigger state location, which is always represented by 0.

The column of state locations along with its data can be rolled to display offscreen data by using the data roll field. The data roll field is the small rectangular box located in the middle of the state location column.

The data roll field is used to either roll the data listing or to select an exact state for display. When the data roll field is light blue, the knob is active and can roll data in either direction. If you touch the data roll field when it is light blue, a pop-up keypad appears for the number of an exact state. When the pop-up keypad is used, the data listing shifts, leaving the selected state in the light blue data roll box.

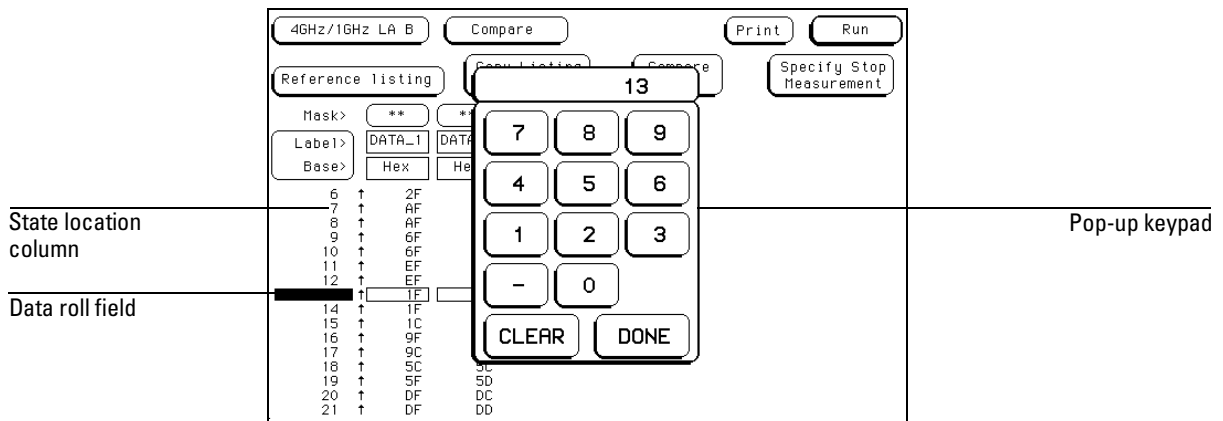

### Data Roll Field

## Bit Editing Field

The bit editing fields are located in the center of the Reference listing display. A bit editing field exists for every label in the display unless the label's base is ASCII. Bit editing fields allow you to modify the values of individual bits in the Reference image or to specify them as don't compare bits.

You access data in the Reference listing by rolling the data listing using the knob until the data is located in the bit editing field. To enter a desired pattern or don't compare (X) for a bit, select the field and use the pop-up keypad which appears.

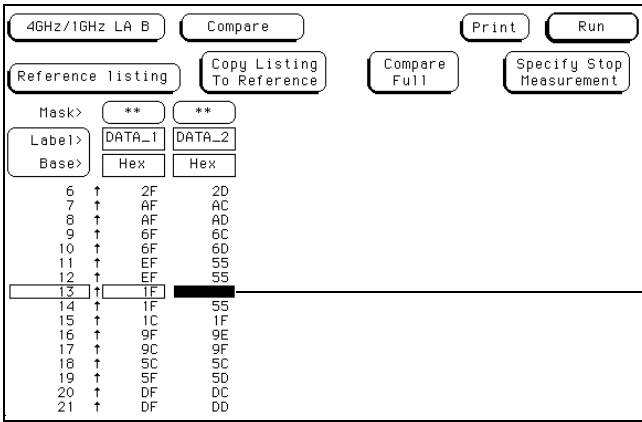

Bit editing field

Bit Editing Field

## Label and Base Fields

The Label and Base fields show up together in all menus except the Format menu. When a new label is assigned, a base field is automatically assigned to that label.

**Label Field** Labels in the Compare menu are the same labels assigned in the Format menu. Labels assigned in the Format menu are displayed throughout the analyzer as they were assigned in the Format menu. To add, delete, or reorder the preassigned labels, select the label you want to modify, then select the desired modify function. From the label selection list that appears, choose the label you want to modify.

**Base Field** All labels have a base field assigned. If the numeric base is changed in a menu, the base in other menus may not change accordingly. For example, the base assigned to symbols is unique, as is the base assigned in the Compare and Listing menus.

The base is changed by selecting the Base field under the desired label, then selecting the new base from a selection menu. The base choices are Binary, Octal, Decimal, Hex, ASCII, Symbol, and Two's complement.

**See Also**

The "Labels Assignment" chapter in the Common Module Operations section in the *HP 16500 Logic Analysis System User's Reference* for more information on assigning labels and rolling labels.





## The Chart Menu

---

## The Chart Menu

Chart is a software post-processing feature that provides the ability to build X-Y graphs of label activity using state data.

The Y axis of the Chart menu always represents data values for a specified label. You can select whether the X axis represents states (rows in the Listing menu) or the data values for another label.

### **Chart Post-Processing Features**

- When the X axis is set to State, X and O markers are available which can be used to search for specific data patterns, document time intervals of interest in timing mode, and gather statistics on the time between specific patterns in timing mode.
- Pattern marker placement is synchronized with the Listing and Waveform menus.
- Accumulate mode allows the chart display to build up over several runs.
- You can set a range of data to plot, scaling both the axes to selectively view only data of interest.
- You can generate XY plots of Label versus Label or Label versus State.

**Label Versus Label Charts**

When labels are assigned to both axes, the chart shows how one label varies in relation to the other for a particular trace record. Label values are always plotted in ascending order from the bottom to the top of the chart and in ascending order from left to right across the chart. Plotting a label against itself will result in points falling along a diagonal line from the lower left to upper right corner. X and O pattern markers are disabled when operating in the label versus label mode.

**Label Versus State Charts**

The Label value versus State chart is a graph of label activity versus the sample number. The label value is plotted against successive analyzer samples.



---

## The Y Markers

### Y1 and Y2 Fields

The Y1 and Y2 markers are used for rescaling data on the vertical axis. Assigning values to these fields can be accomplished in either of two ways. When the field is selected the first time, it turns light blue and operating the knob changes the Y marker value. If the field is selected a second time, a pop-up keypad appears and becomes the entry method for the Y marker value. The Y1 and Y2 markers may be used to zoom in on data of interest in the vertical range. To do this, touch the Rescale field, then select "between Y axis markers." For more information on rescaling data, refer to the "Rescale Field" section later in this chapter.

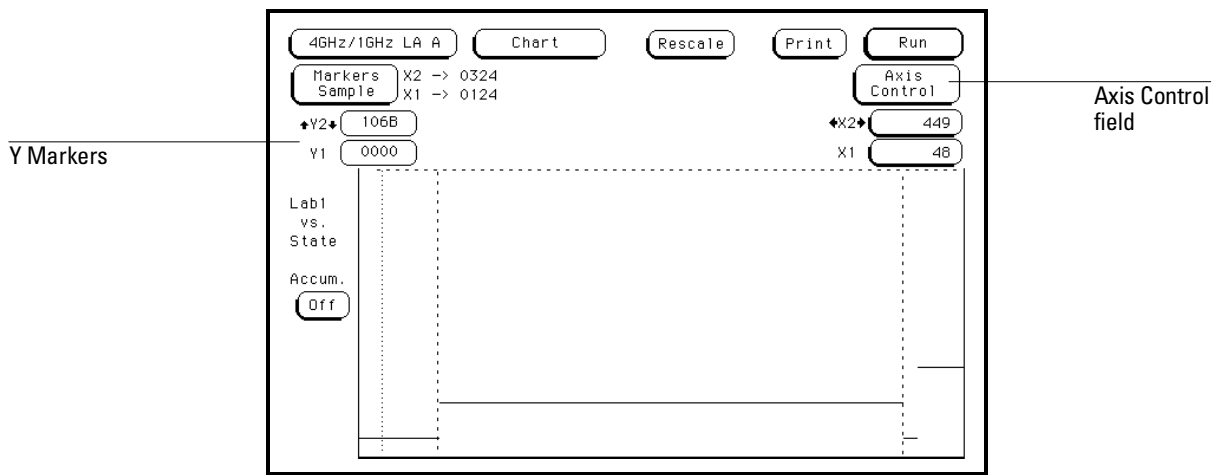

Y Markers for Rescaling the Vertical Axis

---

## Markers Field

The Markers field is used to access the markers selection pop-up. When the Markers field is selected, a marker selection pop-up menu appears. The choices are Sample (the default), Pattern, Time, and Statistics. Sample markers are explained in more detail in the following section; pattern, time, and statistics markers are explained in the "Markers and Stop Measurement" chapter..

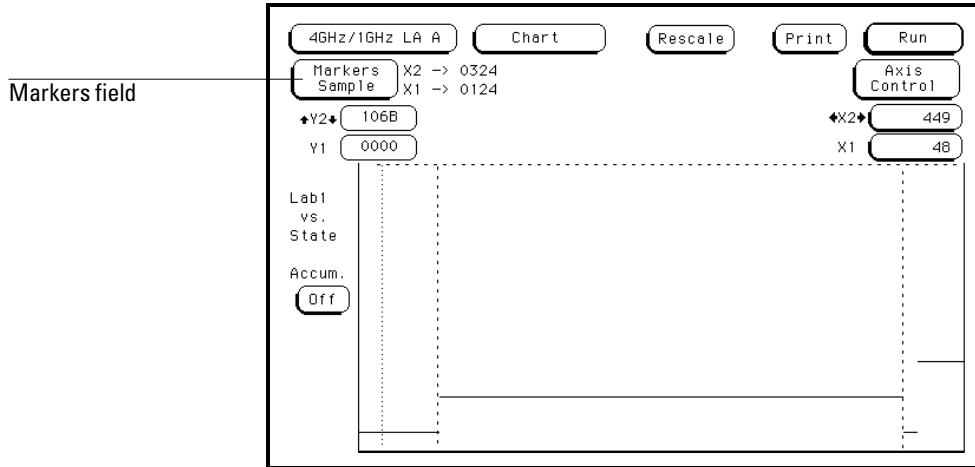

### Markers Field

#### Sample Markers

The Sample selection turns X and O marker operations off, and enables the X1 and X2 markers. The data values at the X1 and X2 markers are automatically displayed to the right of the Marker field when charting label versus state. Data between the X1 and X2 markers may be rescaled. For more information on rescaling, refer to the "Rescale Field" later in this chapter.

If a Compare Stop measurement is specified in the Stop measurement field, and the Stop measurement criteria are met, the measurement will stop even though the Markers are set to Sample. However, an X-O Stop measurement will not complete if Markers are set to Sample.



**X1 and X2 Fields (Markers Sample mode only)**

The X1 and X2 markers are used for displaying and rescaling specific data values. Assigning values to these fields can be accomplished in either of two ways. When the field is selected the first time, it turns light blue and operating the knob changes the value. If the field is selected a second time, a pop-up keypad appears and becomes the entry method. The X1 field positions the green X-axis marker and the X2 field positions the yellow X-axis marker. You can zoom in on the data between the X1 and X2 markers by selecting the Rescale Field and selecting "between X axis markers." For more information on rescaling data, refer to the "Rescale Field" section later in this chapter.

**See Also**

"Markers and Stop Measurement" chapter found in this reference for complete information on pattern, time, and statistics marker operation.

---

**Rescale**

The Rescale field is used to scale the sampled states based on the position of the Y1, Y2, X1, and X2 axis markers. To zoom in on a section of the displayed chart data, position the markers around the area of interest. When the Rescale field is selected, the pop-up menu allows you to choose rescaling between the X axis markers, the Y axis markers, between X&Y axis markers, Full Scale, or Cancel.

**Between X axis markers** This selection rescales data on the X axis based on the X1 and X2 settings. Rescaling places the X1 marker at the left edge of the display and the X2 marker at the right edge of the display.

**Between Y axis markers** This selection rescales data on the vertical Y axis based on Y1 and Y2 settings. Rescaling places the Y1 marker at the top of the display and the Y2 marker at the bottom of the display.

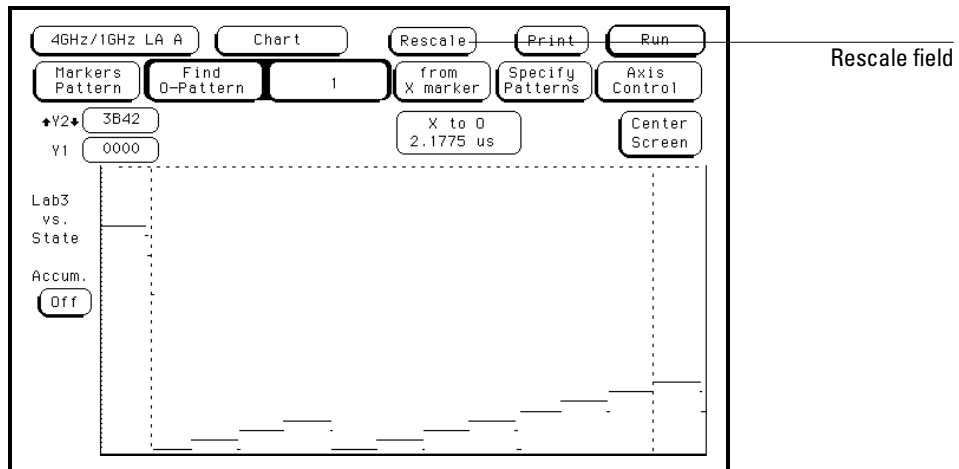

### Rescale Field

**Between X&Y axis markers** This selection will execute both X and Y markers operations as discussed above, resulting in the rescaling of both the horizontal and vertical axes.

**Full Scale** This selection rescales the horizontal and vertical axes so that all data samples are charted in the XY display area. Selecting Full Scale will overwrite Y1, Y2, X1, and X2 settings, in addition to the Axis Control Ranges specified in the Axis Control pop-up menu.

**Cancel** The Cancel selection allows you to exit this pop-up menu without changing the current scaling.



---

## Axis Control Field

Touching the Axis Control field causes a pop-up menu, Chart Axis Control, to appear. In this menu, you specify the relation to be charted and the boundaries for the chart. The vertical Y axis will always be a label. The available labels are those which you defined in the Format menu. The horizontal X axis can be one of the same labels available for the Y axis or it can be samples.

### "XY Chart of" Field (Y-axis Label)

The Y-axis Label field is just to the right of "XY Chart of" text. To specify a vertical axis label, touch the Y-axis Label field then select the desired label from the label list pop-up menu. The label choices are the labels that were defined in the Format menu.

The values charted are the acquired data value represented by that label, in the base selected in the Axis Control menu. The placement of the label data on the chart is determined by the scaling of the two axes. You select values for the axes scaling in the X-axis and Y-axis fields found in the Axis Control menu.

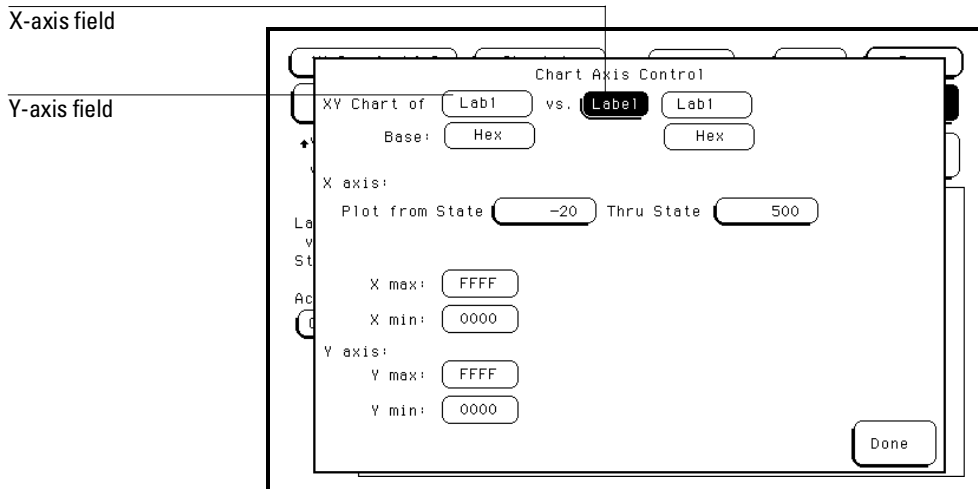

### The Axes Fields



### "vs." State/Label Field (X axis)

The X axis can represent a label's value or location in the sample. The X axis assignment field is just to the right of "vs.", and toggles between State and Label. To assign sample location to the horizontal axis, set this field to State. To assign a label's value to the X axis, set this field to Label. Another field appears to the right of the Label field. Touch this field, and a pop-up menu appears showing all the labels that are defined in the Format menu. Select one of these labels to assign its value to the X axis.

An XY chart, with Y-axis data values for Lab1 of: state 0=15, state 1=16, state 2=17,...,state 99=114, and X-axis data values for Lab2 of: state 0=6, state 1=7, state 2=8,...,state 99=105, would result in the chart coordinates: (6,15), (7,16), (8,17),..., (105,114). The placement of the label data on the X and Y axes is determined by the values of the Xmin, Xmax, Ymin, and Ymax fields.

### X axis and Y axis Fields

Either axis of the XY chart can be scaled by using the associated vertical or horizontal min (minimum) or max (maximum) value fields. When selected, a pop-up keypad appears in which you specify the minimum and maximum values that will be displayed.

When State is selected for the X axis, relative locations of samples are plotted on the X axis. The min and max state locations are specified in the "X axis: Plot from State" field. The trigger state is always location 0.

When Label is selected for the X axis, the minimum and maximum values can range from 0000 (hex) to FFFF (hex) regardless of axis, since labels are restricted to 16 bits for a single-card module.

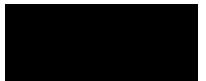

## The Chart Menu Axis Control Field

When plotting Label versus Label, both the Y axis and the X axis can be scaled. Charted memory locations are selectable in the "Plot from State" field for the X axis.

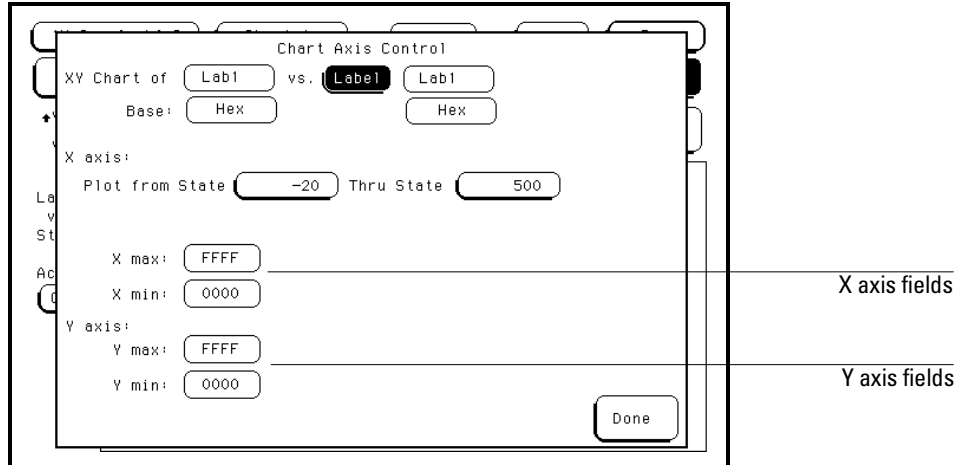

### Axes Scaling Fields

---

## Accumulate Field

The Accumulate field may be toggled between off and on. When Accumulate On is selected, data from multiple acquisitions are charted on top of one another. When Accumulate Off is selected, only the current acquisition is displayed.

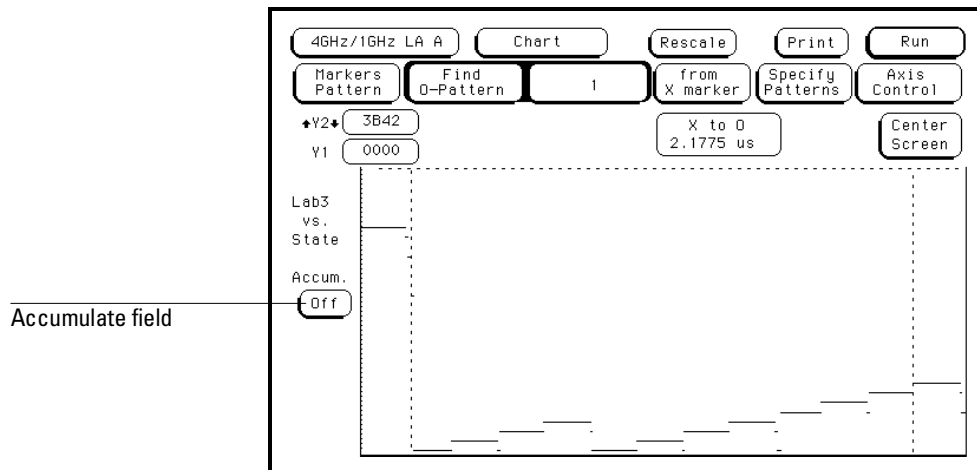

**Accumulate Field**





---

## Markers and Stop Measurements

---

# Markers and Stop Measurements

Marker and stop measurement functions are available in the Listing, Waveform, and Chart menus. Stop measurement is also available in the Compare menu. In each menu, the operation of these functions are very similar. In this chapter you will find field and feature definitions for both the markers and the stop measurement functions for all menus.

## **Markers**

Place color-coded X and O markers within measurement data and use them as reference points for data patterns, time values, gathering statistics, and stop measurement criteria.

## **Stop Measurement**

Use the stop measurement function to stop a repetitive acquisition after predefined criteria are met.

---

## Markers Field

The Markers field may appear in different locations depending on the menu you are in. Regardless of its location, the Markers field is always used to access a marker selection menu.

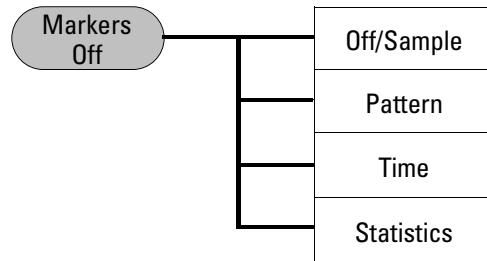

**Off/Sample** Sample appears only in the Chart menu. Off appears in the Listing and Waveform menus. Off and Sample both turn off the X and O markers. Even with Markers turned off, if a Stop measurement has been previously specified, and the Stop measurement criteria are met, the measurement will stop. Be sure to turn off the Stop Measurement to prevent this from happening.

**See Also**

"Sample Markers" subsection in the Chart menu chapter for more information about sample markers.

**Pattern** Pattern markers are available in the Listing, Waveform, and Chart menus. Set Markers to Pattern to place the marker on a specific bit pattern in the data.

**Time** Time markers are available in the Listing, Waveform, and Chart menus. Set Markers to Time to place the marker at a specific time in the acquisition.

**Statistics** Statistics markers are available in the Listing, Waveform, and Chart menus. To use statistics markers, you must first specify a pattern for the X and the O marker. Statistics then keeps track of the minimum, maximum, and average time between the markers for subsequent runs.

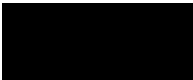

---

# Pattern Markers

When Pattern markers are selected, two markers labeled X and O become available. Pattern markers identify and mark unique bit patterns in the display. Once the unique bit patterns are specified, they can be used as reference points or as criteria for a stop measurement. Even when you move the markers using one of the other modes, the Pattern markers are not changed.

The markers are color coded for easy recognition in the display. The X marker is represented by a green line and the O marker is represented by a yellow line.

When a marker is positioned or moved in the Listing, Chart, or Waveform menus, it is also positioned or moved in the other menus.

## See Also

The "Specify Patterns Field" found later in this chapter for more information on creating a pattern for the X and O markers.

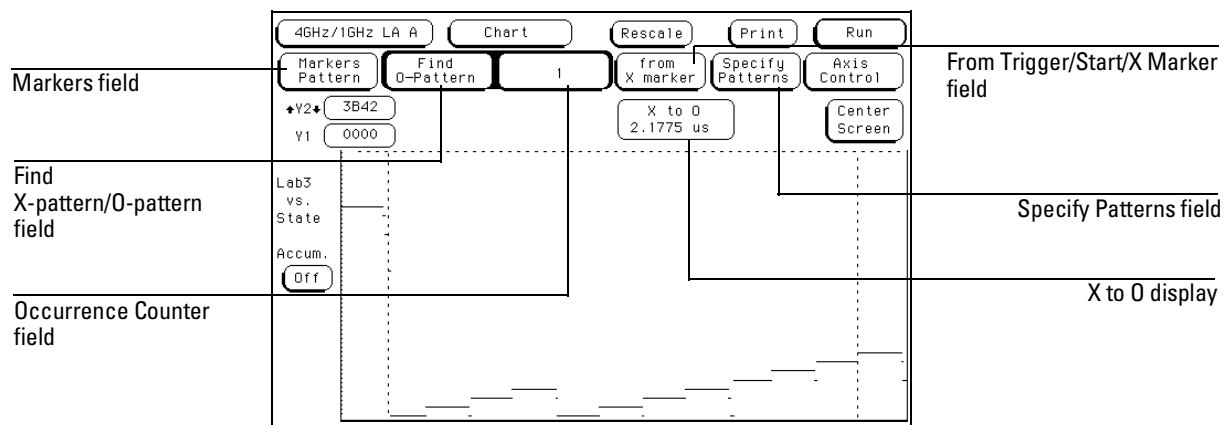

**Chart Menu with Pattern Markers**



## Find X-pattern / O-pattern Field (Listing and Chart)

The Find X-pattern / O-pattern field is a toggle field which is used to select the X or O marker for setup. The marker specifications set in the Occurrence field and the From Trigger / Start / X Marker field affect the pattern marker that is designated in this field. To set the marker specifications for the other marker, toggle the Find X-pattern / O-pattern field and then set the specifications. After toggling to the other marker, the new marked data is found and relocated at center screen.

## Occurrence Counter Field (Listing and Chart)

The occurrence counter field is used to set which pattern occurrence the marker is placed on. The range for the occurrence counter is -131071 to +131071 in the Listing menu and -65535 to +65535 in the Chart menu in Full Channel mode. In Half Channel mode, the range of the occurrence counter is -131071 to +131071 in the Chart menu, and unchanged in the Listing menu.

The trace start point from which the occurrence counter starts searching is either the trigger point, the start of the trace, or in the case of the O-marker, the X-marker. If a negative occurrence number is set, the analyzer will search backwards in time.

4GHz/1GHz LA A   Listing   Acq. Control   Print   Run

Markers Pattern   **Find O-pattern**   1   from X marker   Specify Patterns

Markers field

Find X-pattern/O-pattern field

From Trigger/Start/X Marker field

Specify Patterns field

Occurrence Counter field

Label> Base>	POD 1		POD 2		ALL
	Hex	Absolute	Hex	Hex	
690	02	345.00 ns	21	2102	
691	02	345.50 ns	21	2102	
692	02	346.00 ns	21	2102	
693	02	346.50 ns	21	2102	
694	02	347.00 ns	21	2102	
695	02	347.50 ns	21	2102	
696	02	348.00 ns	21	2102	
<b>697</b>	<b>0A</b>	<b>348.50 ns</b>	<b>21</b>	<b>210A</b>	
698	0A	349.00 ns	21	210A	
699	0A	349.50 ns	21	210A	
700	0A	350.00 ns	21	210A	
701	0A	350.50 ns	21	210A	
702	0A	351.00 ns	21	210A	
703	0A	351.50 ns	21	210A	
704	0A	352.00 ns	21	210A	
705	0A	352.50 ns	21	210A	

Listing Menu with Pattern Markers

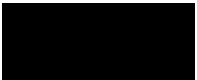

## From Trigger / Start / X Marker Field

The from Trigger/Start/X marker field accesses a selection pop-up for the search start point of the X and O markers.

The start points available for the green X marker are either the beginning of the trace or the trigger point.

The start points available for the yellow O marker are either the trace start point, trigger point, or the X-marker.

If the marker pattern cannot be found, a message appears at the top of the display indicating the search failed. If the O marker is referenced from the X marker, and the X marker is not found, the search for both markers will fail.

**O-pat Occurrence field**

**X-pat Occurrence field**

**Markers field**

Label>	POD 1	Time	POD 2	ALL
Base>	Hex	Absolute	Hex	Hex
690	02	345.00 ns	21	2102
691	02	345.50 ns	21	2102
692	02	346.00 ns	21	2102
693	02	346.50 ns	21	2102
694	02	347.00 ns	21	2102
695	02	347.50 ns	21	2102
696	02	348.00 ns	21	2102
697	0A	348.50 ns	21	210A
698	0A	349.00 ns	21	210A
699	0A	349.50 ns	21	210A
700	0A	350.00 ns	21	210A
701	0A	350.50 ns	21	210A
702	0A	351.00 ns	21	210A
703	0A	351.50 ns	21	210A
704	0A	352.00 ns	21	210A
705	0A	352.50 ns	21	210A

**From Trigger/Start/X Marker field**

**Center Screen field**

**Specify Patterns field**

**Waveform Menu with Pattern Markers**

---

## X-pat / O-pat Occurrence Fields (Waveform menu)

The X-pat and O-pat occurrence fields are used to set which pattern occurrence the marker is placed on. Occurrence counter range is from -131071 to +131071. The reference point from which the occurrence counter starts searching is either the trigger point, the start of the trace, or in the case of the O marker, the X marker. If a negative number is set, the analyzer will search backwards in time.

---

## Center Screen Field (Waveform and Chart)

The Center Screen field accessed a selection pop-up with choices of where to place the marked points of the waveform relative to center screen.

**About Trigger** This choice will position the point of the waveform where the trigger occurred at center screen.

**About X Marker** This choice adjusts the delay to position the point of the waveform where the X-Marker is placed at center screen.

**About O Marker** This choice adjusts the delay to position the point of the waveform where the O-Marker is placed at center screen.

**About X & O** This choice adjusts the sec/Div and delay to allow both the X and O markers to be displayed simultaneously.

---

## X to O Display Field (Waveform and Chart)

Using pattern markers, the X to O display field only appears in the Waveform and Chart menus. The X to O display field shows the time between the X and O pattern markers.

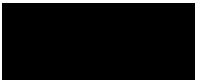

---

## Specify Patterns Field

The Specify Patterns field only appears when the markers are set to Pattern. When the Specify Patterns field is selected, a pop-up menu appears that is used to assign the bit patterns for the clocked X and O markers, the X and O entering/leaving, and the Stop measurement criteria.

### **X and O entering / leaving Fields**

Using this option, the X and O pattern markers are placed at the beginning of the pattern occurrence (entering) or at the end of the pattern occurrence (leaving), regardless of where the sample clock occurs. This means that in state mode a marker could be placed on an oversampled point.

The pattern you place in the pattern display field will apply to the marker labeled at the left.

### **X and O Clocked Fields (State only)**

If the analyzer is configured in the state acquisition mode, X clocked and O clocked options are included with the X and O entering/leaving options. If the pattern is seen, and it occurred on an externally clocked sample point, the marker is placed. The marker will not be placed on a pattern occurrence on an oversampled point using the "clocked" options. The pattern you place in the pattern display field will apply to the marker labeled at the left.

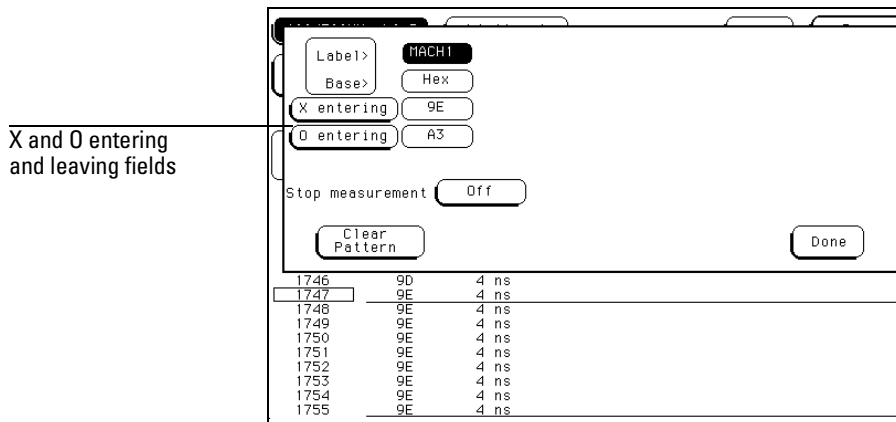

### **X and O entering / leaving Fields**

### Pattern Display Fields

The pattern display fields display the alphanumeric bit pattern specified for each X and O marker in all designated labels. The bit pattern is displayed in the same numeric base as the data listing. When the pattern display field is selected, a pop-up keypad appears which is used to set the bit pattern.

### Label and Base Fields

The Label and Base fields show up together in all menus except the Format menu. When a new label is created in the Format menu, a base field is automatically assigned to that label.

**Label Field** Labels in the Specify Patterns menu are the same labels assigned in the Format menu. These labels are displayed throughout the analyzer as they were assigned in the Format menu.

To reorder currently displayed labels, select the label you want to move, then from the selection menu that appears, choose the label you want to switch positions with.

**Base Field** All labels have a base field assigned. If the base is changed in a menu, the base in other menus may not change accordingly. For example, the base assigned to symbols is unique, as is the base assigned in the Compare and Listing menus.

The base is changed by selecting the Base field under the desired label, then selecting the new base from a selection menu. The base choices are Binary, Octal, Decimal, Hex, ASCII, Symbol, and Twos.

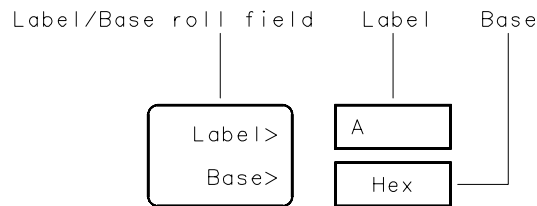

16542B03

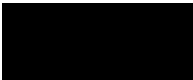

## Stop Measurement Field

The Stop measurement function allows you to specify a condition that stops the analyzer measurement during a repetitive run.

When the Stop measurement field is selected, a Stop measurement type menu appears. You have the choices of Off, X-O, and Compare.

### **Off**

The Off selection turns all Stop measurement operations off.

If the Stop measurement operation is not turned off and the stop criteria are met, the measurement will stop even though the markers are set to other types or turned off. The only exception is the Chart menu: an X-O Stop measurement will not complete if the markers are set to Sample.

### **X-O**

X-O is the time between the X and O markers. When X-O is selected, a repetitive run is stopped when a comparison of the time period between the X and O markers and one of the following time period options is true:

**Less Than** X-O time must be less than the time value that you specify in the Time field.

**Greater Than** X-O time must be greater than the time value that you specify in the Time field.

**In Range** X-O time must be within the time range value that you specify in the two Time fields.

**Not in Range** X-O time must not be within the time range value that you specify in the two Time fields.

### **Compare**

When Compare is selected, a repetitive run is stopped when a comparison of data in the Listing menu and masked data in the Reference listing of the Compare menu matches an equality selection. The equality selection is set from the Equal/Not Equal selection pop-up menu.

Changing the Stop measurement criteria in the Specify Patterns pop-up menu also changes the settings in the Specify Stop Measurements pop-up menu in the Compare menu.

**Equal** The data and compare criteria in the Compare menu must be equal to the data in the Listing menu.

**Not Equal** The data and compare criteria in the Compare menu must not be equal to the data in the Listing menu.

---

### **Clear Pattern Field**

The Clear Pattern field is used to reset the X and O Marker pattern display fields back to default (don't care = X). The Clear Pattern field accesses a selection menu with the choices of All, X pattern, or O pattern.



# Time Markers

Time markers are indicators located in the data listing or waveform display that are used as reference marks to obtain time values between each marker, or between each marker and the trigger point.

The markers are color coded for easy recognition. The X marker is represented by a green line and the O marker is represented by a yellow line.

If Pattern markers have been assigned, the Time markers will be initially placed at the same locations in the data listing.

The screenshot shows a software interface with several buttons at the top: "4GHz/1GHz LA A", "Listing", "Acq. Control", "Print", and "Run". Below these are four marker display boxes: "Markers Time", "Trig to X -472.50 ns", "Trig to O 326.50 ns" (highlighted with a green border), and "X to O 799.00 ns". A line from the "X to O" box points to the text "X to O Display". Below the markers is a table with columns for "Label", "Base", "POD 1", "Time", "POD 2", and "ALL". The table contains data for addresses 640 to 655. A line from the "Trig to X and Trig to O Fields" text points to the "Time" column of the table.

Label>	POD 1	Time	POD 2	ALL
Base>	Hex	Absolute	Hex	Hex
640	00	320.00 ns	25	2500
641	00	320.50 ns	25	2500
642	00	321.00 ns	21	2100
643	00	321.50 ns	21	2100
644	00	322.00 ns	21	2100
645	00	322.50 ns	21	2100
646	00	323.00 ns	21	2100
647	00	323.50 ns	21	2100
648	00	324.00 ns	21	2100
649	00	324.50 ns	21	2100
650	00	325.00 ns	21	2100
651	00	325.50 ns	21	2100
652	02	326.00 ns	21	2102
653	02	326.50 ns	21	2102
654	02	327.00 ns	21	2102
655	02	327.50 ns	21	2102

**Listing Menu with Time Markers**



---

## Trig to X / Trig to O Fields

The Trig to X and Trig to O fields are display fields as well as configuration fields. Marker position is set by selecting the fields, then after the fields turn light blue, rotating the knob. Marker position can also be set by selecting the light blue field a second time, then entering a value.

The Trig to X and Trig to O fields display the time between the trigger point and the marker.

### X to O Display Field

The X to O display field is a "read only" field when it occurs in the Listing or Chart menu, but is a configurable field in the Waveform menu. It displays the time between the X and O markers. As the X and O markers are changed, the display changes accordingly. A negative value means the O marker is placed earlier in the trace than the X marker.

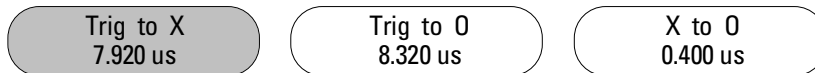

---

## Marker Label / Base and Display (Waveform menu)

When using Time markers, a readout of marker values (where both markers are currently placed) is shown.

The label field displays the label name to which the X and O marker values are assigned. To display other labels, select the label field and choose the new label from the selection menu that appears. Only pre-assigned labels in the Format menu are available in the label selection menu

The base field underneath the label field displays the base the marker values are in. To change the base, select the base field then choose the desired base from the selection menu.

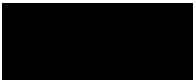
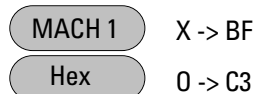

---

## Statistics Markers

After patterns are assigned to the X and O markers, statistical information becomes available when markers are set to Statistics. The logic analyzer displays the following information:

- Number of valid runs (runs where Pattern markers were able to be placed on specified patterns).
- Minimum time between the X and O Pattern markers.
- Maximum time between the X and O Pattern markers.
- Average time between the X and O Pattern markers.

The markers are color coded for easy recognition in the data listing. The X marker is represented by a green line and the O marker is represented by a yellow line.

Statistics are based on the time between the X and O. Both markers must be found before valid statistical information is displayed.

In repetitive run mode, the display is updated each time a valid run occurs until you select Stop.

In single run mode, each time you select Run an additional valid run will be added to the data and the statistics will be updated. This process continues unless you change the placement of the X and O Pattern markers between runs.

---

## Reset Statistics Field (Waveform menu)

The Reset Statistics field only appears in the Waveform menu, and when using Statistics Markers. It is used to clear all statistic displays, and reset them to zeros.

---

## Clear Statistics Field (Chart menu)

The Clear Statistics field only appears in the Chart menu, and when using Statistics Markers. It is used to clear all statistic displays, and reset them to zeros.







Skew Adjust

---

## Skew Adjust

This chapter gives you instructions for calibrating and adjusting the HP 16517A/18A module. Though the specifications are not tested during these procedures, the module must be adjusted to ensure the specifications will be met.

The adjustment to the high-speed logic analyzer consists of skew adjustment to minimize channel-to-channel skew. The adjustment factors are stored in nonvolatile RAM, and are loaded up at system start up.

To periodically verify the performance of the HP 16517A/18A against the module specifications, refer to "Testing Performance" in the optional *HP 16517A/18A Service Guide*, available from your Hewlett-Packard Sales Office.

---

### To Calibrate the Data Acquisition Module

The HP 16517A/18A does not require an operational accuracy calibration. To test the module against the module specifications, refer to "Testing Performance" in the optional *HP 16517A/18A Service Guide*, available from your HP Sales Office.

---

## To Adjust the Channel-to-Channel Skew

**Table 10-1**

<b>Equipment Required</b>			
<b>Equipment</b>	<b>Critical Specification</b>	<b>Recommended Model/Part</b>	<b>Qty</b>
Calibration Module	No Substitutes	HP 16517-63201	1
BNC Coax Cable		HP 10503A	1

---

### Connect the Logic Analyzer

- 1 Connect one end of the BNC cable to the calibration output port on the rear panel of the HP 16517A master board.
- 2 Connect the other end of the BNC cable to the BNC Signal Input of the calibration module.

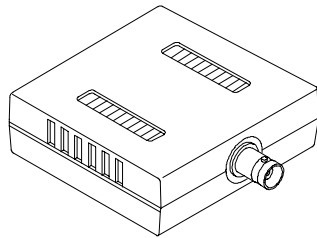

16517E13

**HP 16517A Calibration Module**

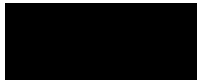

---

## Set Up the Logic Analyzer

- 1 Go to the Skew Adjust menu.
  - a In the System Configuration menu, touch System, and select 4GHz/1GHz LA from the pop-up menu.
  - b Touch Format. In the pop-up menu, touch Skew Adjust.
- 2 In the Skew Adjust menu, select Adjust Clock and Data Path Deskew.

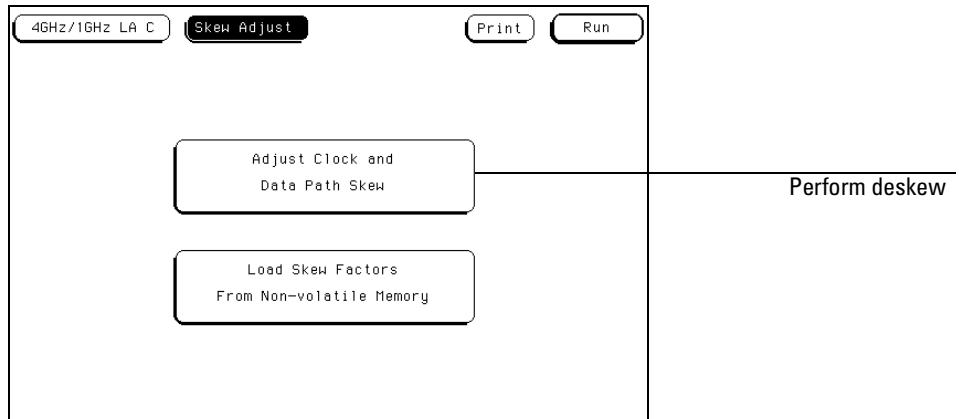

**Skew Adjust Menu**



- 3 Follow the instructions on the screen to connect the pods to the calibration module. After connecting the pod to the calibration module, touch Proceed.

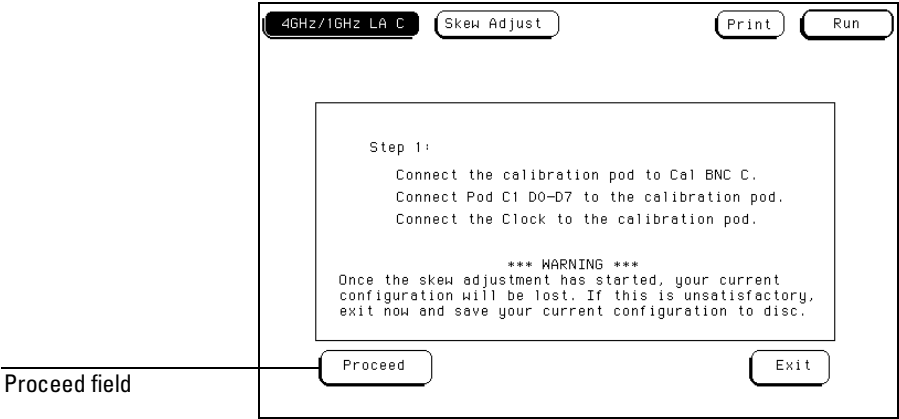

**Adjust Clock and Data Path Skew Menu**

- 4 Continue following the instructions on the screen to connect the various pods to the calibration module until all pods are skew adjusted.

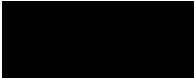

---

## To Save or Discard the Skew Factors

When the skew adjustment is complete, the choice is given to save or not save the skew factors. To not save the skew factors, touch Do NOT Save Skew Factors. To save the skew factors, touch Save Skew Factors.

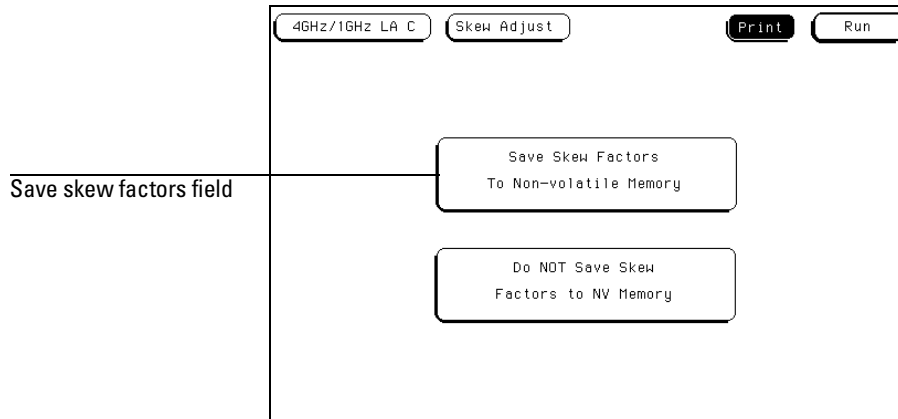

### Save Skew Factors



## Error Messages

---

# Introduction

This chapter lists the error messages, warning messages, and advisory messages that may be encountered during operation of the analyzer. Error messages have a red background, warning messages have a yellow background, and advisory messages have a green background.

If an error is encountered during analyzer configuration or general operation, there could be more than one cause for the problem. In most cases, the analyzer is configured improperly.

If you are performing a calibration or performance verification (PV) and receive any messages, refer to the last section of this chapter "Calibration and Performance Verification Messages."

## **For more information**

If any messages are encountered while running Self Tests, refer to the optional *HP 16517A/18A Service Guide* for information on test descriptions and troubleshooting procedures. You can order the Service Guide through your HP Sales Office.

---

## Error Messages

**ASCII entry not available.** The ASCII base is not available. You must use another base selection.

**Failure to Read Skew Values from Flash ROM.** The logic analysis system could not load skew values from ROM and is using default skew values instead. This message occurs the first time the HP 16517A/18A module is powered up, or if there are no skew values in the HP 16500 logic analysis system. See the Skew Adjust chapter for how to set skew values.

**Insufficient memory to load IAL - load aborted.** There is not a large enough block of free memory to load the inverse assembler.

**Inverse assembler not loaded - bad object code.** Corrupt inverse assembler file. Try getting another copy of the inverse assembler file and loading that.

**Maximum of 32 channels per label.** This message appears when you try to assign more than 32 channels to a single label. The logic analyzer will only allow 32 channels to be assigned to any single label.

**Measurement Did Not Complete** The user was adjusting skew or running a PV test that did not complete as it should have. The logic analysis system attempted to measure skew values but could not complete the measurement. Default skew values are used instead.

**Memory system failed -- replace card(s)** A fault was detected in the module's memory. Send the specified card(s) in for repair. See "Installation and Service" chapter for more information.

**Must have at least 1 edge specified.** You must assign at least one clock edge to one of the available clocks in the Master clocking arrangement. In addition, if the Slave clock is being used, it must have at least one clock edge assigned. The analyzer will not let you close the clock assignment pop-up menu until an edge is specified.

**NO DISK.** There are no disks in the disk drives. You must place a disk into the disk drive before configurations can be loaded or stored.

**Problems reading file.** The user is trying to translate a configuration file that cannot be opened a second time.

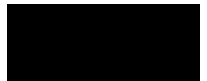

**Selected file is incompatible** The file being loaded cannot be translated into the HP 16517/18A.

**Time correlation of data is not possible.** Before time correlation of data is possible, time tags must be placed on the data. If you want time correlated data, set the Count field in the Trigger menu to Time.

**Unable to Detect WRAP Flag. Possible Board Fault.** The WRAP flag is not being set, which could indicate a memory problem. Run the self tests to verify performance.

---

## Warning Messages

**Cannot read unrecognized data.** The logic analysis system is trying to translate a SPA configuration from a foreign module.

**Changes to Sequence and Terms Since "Break Down" Will Be Lost!** The user has selected Restore Macros from Modify Trigger. If the user chooses to proceed, any changes made in the macros will be lost.

**Clock pod and least significant pods have been preserved.** User is loading a configuration with number of pods greater than the current system's number of pods.

**Clock Qualifiers not fully restored.** The user is trying to translate a configuration that has clock qualifiers. The HP 16517/18A cannot implement clock qualifiers.

**Compare not available - Insufficient Memory.** There is not enough memory available to store a compare image.

**Computing chart information. Please Wait.** This message is displayed when the analyzer is busy computing the data to be charted. When the computing is finished, the new chart will be displayed.

**Delay set to limit.** The Delay field is set to its limit.

**Demultiplexed clocking cannot be translated.** The HP 16517/18A is trying to load a configuration that has demultiplexed or mixed clocks.

**Error loading DISPLAY1.** User is loading a configuration with a corrupt DISPLAY1 section.

**Error not found.** The Find Error number specified could not be found.

**Machine name: "filename" inverse assembler not found.** This message appears when the inverse assembler file could not be found.

**Need to have two free sequence levels.** For each sequence level with a "<" assigned, you must leave two sequence levels free. To free up two levels, simply delete two levels.

**NOTE: 500 MHz Trigger Sequencer Rate Exceeds Sample Rate.** This message appears when the sample period in the acquisition control menu is set to a lower rate than the sequencer. Because of the slow sampling rate, the trigger may not be included in the trace.

**NOTE: Sample Rate Exceeds 500 MHz Trigger Sequencer Rate.** This message appears when the sample period in the acquisition control menu is set to a faster rate than the trigger sequencer.

**NOTE: Trigger Sequencer Will Not See Oversampled States.** The user has changed the oversampling value. This message warns that if the trigger occurs on an oversampled state, the sequencer will not detect it and thus will not trigger on that instance.

**Pods have been truncated.** User is loading a configuration with number of chips greater than the current system's number of chips.

**s/Div set to limit.** The sec/Div or states/Div field is set to its limit.

**Search failed - X pattern not found.** The X pattern specified could not be found, therefore the pattern marker could not be placed in the data.

**Search failed - O pattern not found.** The O pattern specified could not be found, therefore the marker could not be placed in the data.

**Skew adjustment halted, recalling stored values** The user has selected Exit after beginning the skew adjust procedure.

**Slow or missing clock.** This message indicates a slow or missing clock. This is displayed for a state analyzer only until the first clock occurs.

**The clock is not connected properly.** The module did not detect a clock. A clock signal is necessary for skew adjustment.

**Trigger May Not Be Included In Acquired Data.** The trigger event, although detected, may not be included in the displayed trace because the sample rate is low. You may want to decrease the sample period in the acquisition control menu. See the chapter on the Trigger menu.



**User thresholds have been truncated.** The logic analysis system is trying to translate a configuration having thresholds greater than 6 Volts or less than -6 Volts.

**Using Default 16517/18 Skew Values. Please See "Skew Adjust" Menu.** The logic analysis system was unable to locate skew values in ROM and is using default values. To change the skew value, follow the instructions in the Skew Adjust chapter.

**Waiting for Prestore.** This message is displayed for a timing analyzer waiting for prestore.

**Warning: Run HALTED due to variable change.** This message appears when certain analyzer settings are changed during a repetitive run. When this occurs, the analyzer stops.

**Xmin is equal to Xmax.** The value assigned to X minimum is equal to the value assigned to X maximum.

**Xmin is greater than Xmax.** The value assigned to X minimum is greater than the value assigned to X maximum.

**Ymin is equal to Ymax.** The value assigned to Y minimum is equal to the value assigned to Y maximum.

**Ymin is greater than Ymax.** The value assigned to Y minimum is greater than the value assigned to Y maximum.



---

## Advisory Messages

**Charting line: <number>** The logic analysis system is redrawing the chart display.

**Insert failed - Maximum of 60 entries.** 60 listing columns is the maximum number allowed. This advisory appears when you try to configure more than 60 columns.

**No valid data. Reference memory cleared.** This advisory appears when the Copy Listing To Reference field is selected in the Compare menu and there is no listing data to copy.

**Occurrences Remaining in Level "n".** The analyzer is waiting for the specified level to be satisfied. This advisory is used in analyzers that use the Occurs parameter.

**Waiting in Level "n".** The analyzer is waiting for the specified level to be satisfied. This advisory is used in analyzers that use the > or < parameter.



## Skew Adjust and Performance Verification Messages

The following Error, Warning, and Advisory messages may be encountered when performing the skew adjust or performance verification testing. Error messages have a red background and indicate that the measurement, or part of the measurement, will not occur until the problem is fixed. Warning messages have a yellow background, and indicate that the measurement, or part of the measurement may be at risk if the operation is not understood.

### Error Messages

**Measurement Did Not Complete.** The user was adjusting skew or running a PV test that did not complete as it should have.

**Could not complete fine deskew.** The calibration was unable to complete the fine cal binary search.

**Could not complete coarse deskew.** The calibration was unable to find the high and low values needed by the fine cal binary search.

**Could not start deskew.** The calibration was unable to make the first acquisition needed to start the coarse cal.

**Deskew Failed!.** The calibration did not find valid numbers.

**Unable to find the leading/trailing edge.** The clock deskew cannot identify the leading (rising clock) or trailing edge (falling clock).

**get\_ackdly\_bits() failed.** The second clock offset cannot be set to the desired value.

### **Warning Messages**

**Skew adjustment halted, recalling stored values.** Calibration was halted before it completed.

**Skew adjustment failed, recalling stored values.** This message appears when any calibration fails.

**Skew adjustment failed. Press "Proceed" to retry or "Exit" to quit.** This message appears when any calibration fails, but only before the user retries or quits.

**16517/18 Skew values do not match HW configuration.** The hardware configuration corresponding to the calibration factors stored do not match the current configuration in the frame.

**Using Default 16517/18 Skew Values. Please See "Skew Adjust" Menu.** Since no valid calibration values were found in flash ROM, or those read do not match the current hardware, the default values are being loaded. The board skews should be re-adjusted.

### **Advisory Messages**

**Previous configuration: A:16518 B:16518 C:16517 D:16518 E:16518.** This message describes the configuration that produced the stored calibration factors.

**Please adjust the skew or re-configure the module.** This message appears after CAL\_HW\_MISMATCH, CAL\_CONFIG and DFT\_CAL\_MSG are detected. Adjust the skew, or reconfigure the module.

**The clock is not connected properly.** The module was unable to measure a signal on the clock as part of the calibration process.

**Data channels (.....) are not connected properly.** The module was unable to measure a signal on any of the data channels as part of the calibration process.





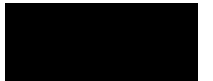

---

## Specifications and Characteristics

---

## Specifications and Characteristics

This chapter lists the specifications and characteristics. Specifications are the performance standards against which the product is tested.

Characteristics are not specifications, but are included as additional information.

For complete information on the test procedures to verify product performance, refer to the optional *HP 16517A/18A Service Guide*, available from your HP Sales Office.

For instructions on running the self-tests, see the "Installation and Service" chapter in this reference.

---

## Specifications

The specifications are the performance standards against which the product is tested. They are specified for an input signal  $V_H = -0.9V$ ,  $V_L = -1.7V$ , slew rate =  $1V/ns$ , and threshold =  $-1.3V$ .

**Minimum Input Voltage Swing:** 500 mV peak to peak.

**Threshold Accuracy:**  $\pm 2\%$  of input signal  $\pm 50$  mV.

**Minimum External Clock Period:** 1 ns.

**Setup/Hold:**

Per pod\* 350 ps/350 ps.

Across pods 750 ps/750 ps.

350 ps/350 ps, with manual deskew.

Actual setup/hold adjustable with sample offset in all modes.

\* For the frequency range of 62.5 MHz to 20 MHz, a duty cycle of 40% to 60% is required.

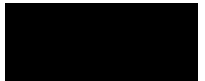

---

## Characteristics

The characteristics are not specifications, but are included as additional information.

### Probes

**Input DC Resistance:** 100 K $\Omega$ ,  $\pm$  2%.

**Input Impedance:**

DC through 400 ns rise time                      100 K $\Omega$ , typical.

3.5 ns through 350 ps                              500  $\Omega$ , typical.

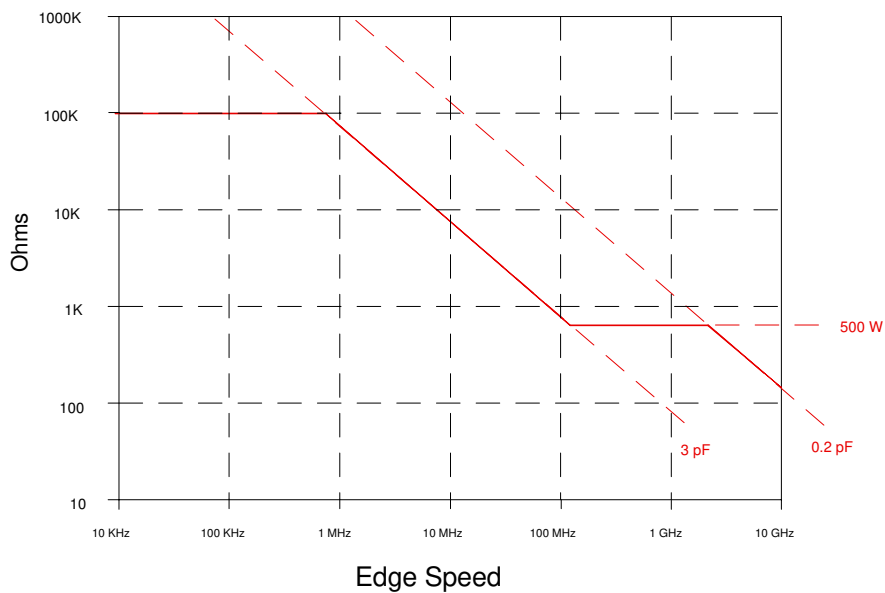

### Impedance Plot



**Probes**

**Input Capacitance:** 0.2 pF and then, through 500  $\Omega$ , 3 pF.

**Minimum Input Overdrive:** 250 mV or 30% of input (whichever is greater) above the pod threshold.

**Threshold Range Increments:**  $\pm 5.0$  V in 10 mV increments.

**Threshold Setting:** Preset TTL, ECL, or User-defined on a per pod basis.



**Input Dynamic Range:**  $\pm 5$  V about the threshold.

**Maximum Input Voltage:** 40 V peak-to-peak, CAT 1.

**Synchronous State  
Analysis**

**Maximum External Clock Speed:** 1 GHz, requires a periodic clock.

**Minimum State Speed:** 20 MGSa/s, requires a periodic clock.

**Minimum Detectable Pulse Width:** 900 ps.

**Channel Count:** 16 per card, up to 80 in one frame.

**Channel-to-Channel Skew across up to 80 channels:**

Per pod	250 ps, typical.
Across pods	1 ns, typical. 250 ps, with manual deskew.

**Memory Depth per Channel:** 65536 samples.

**State Clocks:** One external clock is available on the master board. No clocks are available on the expander board. Clock edge is selectable as positive or negative.

**State Clock Duty Cycle Range:**

1 GHz through 500 MHz	45% - 55%, typical.
500 MHz through 250 MHz	30% - 70%, typical.
250 MHz through 20 MHz	20% - 80%, typical.

**Oversampling:** 2x, 4x, 8x, 16x, and 32x, with a maximum rate of 2 GSa/s.

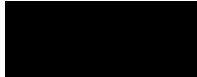

**Timing Analysis**

**Timing Modes:** Conventional timing.

**Timing Speed:** 15.3 KSa/s – 2 GSa/s full channel, 4 GSa/s half channel.

**Sample Period:** 500/250 ps minimum (full/half channel mode),  
65.536  $\mu$ s maximum.

**Channel Count:** 16/8 per card (full/half channel mode).

**Minimum Detectable Pulse Width:**

4 GSa/s                    800 ps, typical.

2 GSa/s or less        1.1 ns, typical.

**Memory Depth per Channel:** 65536 samples full channel mode;  
131072 samples, half channel mode.

**Time Covered by Data:** 32.8  $\mu$ s at 2 GSa/s or 4 GSa/s up to 4.3 s at  
15.3 KSa/s.

**Time Interval Accuracy:**  $\pm$  (sample period + channel-to-channel skew  
+ 0.005% of time interval reading).

**Sample Period Accuracy:** 0.005% of sample period.

**Channel-to-Channel Skew across up to 80 channels:** 250 ps,  
typical.

**Maximum Delay After Triggering:** (2 to the 20th) $\times$ (sample period),  
or 16.78 ms at or below 16 ns sample period.

Note: When oversampling, use oversampled period for sample period above.

**Trigger  
Characteristics**

**Pattern Recognizers:** 4. Each pattern recognizer is the AND  
combination of bit (0, 1, or X) patterns.

**Pattern Width:** 16/32/48/64/80 channels.

**Minimum Pattern Recognizer Pulse Width:** 2.25 ns.

**Edge Recognizers (Timing only):** 2. Trigger on a rising, falling, or  
either edge on any channel. Edges are OR'd across all channels.

**Edge Width:** 16/32/48/64/80 channels.

**Edge Counting Frequency:** 444 MHz.

**Edge Detection:** Up to 1 GHz.

**Greater than Duration (Timing only):** 0 ns – 510 ns, accuracy is  $\pm 2.25$  ns.

**Less than Duration (Timing only):** 4 ns – 510 ns, accuracy is  $\pm 2.25$  ns.

**Qualifier:** A user-specified term that can be any state, no state, any recognizer (patterns or edges), the timer, or the logical combination (AND, OR, XOR) of the recognizers and timers.

**Branching:** Each sequence level has two branching qualifiers. When satisfied, the analyzer will branch to the specified sequence level.

**Maximum Occurrence Count:** 16,777,216.

**Maximum Sequencer Speed:** 500 MHz.

**State Sequence Levels:** 4 plus trace point.

**Timing Sequence Levels:** 4 plus trace point.

**Timer/Counter:** There is one timer or counter per sequence level, which is restarted upon entry into each level.

**Timer/Counter Range:**

Timing mode 0 s to 33 ms.

State mode 500 MHz to 1 GHz, (user clock period) $\times$ (2 to the 23rd).  
below 500 MHz, (user clock period) $\times$ (2 to the 24th).

**Timer Resolution:**

Timing mode 2 ns.

State mode above 500 MHz,  $2 \times$  user clock period.  
below 500 MHz, user clock period.

**Timer Accuracy:** 0.005% of timer value.



**Measurement and Display Functions**

**Arming:** Can be armed by the Run key, the external SMB, or the Intermodule Bus (IMB).

**Trace Mode:** Single mode acquires data once per trace specification. Repetitive mode repeats single mode acquisitions until Stop is pressed or until pattern time interval or compare stop criteria are met.

**Labels:** Channels may be grouped together and given a 6-character name. Up to 126 labels may be assigned with up to 32 channels per label in each analyzer. Trigger terms may be given an 8-character name.

**Activity Indicators:** Provided in the Format menu for monitoring device-under-test activity while setting up the analyzer. The indicators only function when the analyzer is stopped.

**Pod ID:** A button provided on each pod which, when pressed, causes the display of its slot letter and pod number on the analyzer screen.

**Markers:** Two markers (X and O) are shown as dashed lines in the display.

**Trigger:** Displayed as a red vertical dashed line in the waveform and chart display and as line 0 in the listing and compare displays.

**Measurement Functions**

**Run:** Starts acquisition of data in specified trace mode.

**Stop:** In single trace mode or the first run of a repetitive acquisition, Stop halts acquisition and displays the current acquisition data. For subsequent runs in repetitive mode, Stop halts acquisition of data and does not change current display.

**Time Interval:** The X and O markers measure the time interval between events.

**Patterns:** The X or O marker can be used to locate the nth occurrence of a specified pattern before or after trigger, or after the beginning of data. The O marker can also find the nth occurrence of a pattern before or after the X marker.

**Statistics:** X to O marker statistics are calculated for repetitive acquisitions. Patterns must be specified for both markers, and statistics are kept only when both patterns can be found in an acquisition. Statistics are minimum X to O time, maximum X to O time, average X to O time, and ratio of valid runs to total runs.

**Compare Mode Functions:** Performs a post-processing bit-by-bit comparison of the acquired state data and Compare Reference data.

**Compare Reference:** Created by copying an acquisition into the compare reference buffer. Allows editing of any bit in the Compare Reference to a 1, 0 or X.

**Compare Reference Boundaries:** Each channel (column) in the compare reference can be enabled or disabled via bit masks. Upper and lower ranges of states (rows) in the compare reference can be specified. Any data bits that do not fall within the enabled channels and the specified range are not compared.

**Stop Measurement:** Repetitive acquisitions may be halted when the comparison between the current acquisition and the Compare Image is equal or not equal.

**Compare Mode Display:** Reference Listing display shows the Compare Reference and bit masks. Difference Listing display highlights differences between the current acquisition and the Compare Reference.

#### Data Entry/Display

**Display Modes:** Listing, Waveform, Chart, Compare Reference Listing, and Compare Difference Listing. Time-correlated oscilloscope traces can also be displayed in the waveform display mode when the intermodule bus is used.

**Markers:** Correlated to listing, chart, and waveform displays. Available as pattern, time, or statistics.

**Waveform Displays:** Display acquisition in waveform format.

**Sec/div:** 250 ps to 50 s.

**Delay:** -2,500 s to +2,500 s.

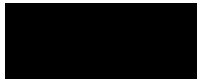

## Specifications and Characteristics

### Characteristics

**Accumulate:** Waveform display is not erased between successive acquisitions.

**Overlay Mode:** Multiple channels can be displayed on one waveform display line. When waveform size is set to large, the value represented by the waveforms is displayed inside the waveforms in selected base.

**Displayed Waveforms:** 24 lines maximum on one screen. Up to 96 lines may be specified and scrolled through.

**Bases:** Binary, octal, decimal, hexadecimal, ASCII (data displays only), user-defined symbols, and two's complement.

**Pattern Symbols:** User can define a mnemonic for the specific bit pattern of a label. When label base is SYMBOL, mnemonic is displayed where the bit pattern occurs.

**Range Symbols:** User can define a mnemonic covering a range of values. When data display is SYMBOL, values within the specified range are displayed as mnemonic + offset from base of range.

**Number of Symbols:** 1000 maximum.

#### Operating Environment

<b>Temperature</b>	Instrument, 0 °C to 55 °C (+32 °F to 131 °F). Probe lead sets and cables, 0 °C to 65 °C (+32 °F to 149 °F).
<b>Humidity</b>	Instrument, probe lead sets, and cables, up to 95% relative humidity at +40 °C (+122 °F).
<b>Altitude</b>	To 4600 m (15,000 ft).
<b>Vibration</b>	Operating: Random vibration 5 to 500 Hz, 10 minutes per axis, ≈ 0.3 g (rms). Non-operating: Random vibration 5 to 500 Hz, 10 minutes per axis, ≈ 2.41 g (rms); and swept sine resonant search, 5 to 500 Hz, 0.75 g (0-peak), 5 minute resonant dwell at 4 resonances per axis.



---

## Installation and Service

---

# Preparing for Use

This chapter gives you instructions for preparing the logic analyzer module for use, and for performing periodic maintenance.

## **Power Requirements**

All power supplies required for operating the logic analyzer are supplied through the backplane connector in the mainframe.

## **Operating Environment**

The operating environment is listed in chapter 12. Note the noncondensing humidity limitation. Condensation within the instrument can cause poor operation or malfunction. Provide protection against internal condensation.

The logic analyzer module will operate at all specifications within the temperature and humidity range given in chapter 12. However, reliability is enhanced when operating the module within the following ranges:

- Temperature: +20 °C to +35 °C (+68 °F to +95 °F)
- Humidity: 20% to 80% noncondensing

## **Storage**

Store or ship the logic analyzer in environments within the following limits:

- Temperature: -40 °C to +75 °C
- Humidity: Up to 90% at 65 °C
- Altitude: Up to 15,300 meters (50,000 feet)

Protect the module from temperature extremes which cause condensation on the instrument.



---

## To Inspect the Module

### 1 Inspect the shipping container for damage.

If the shipping container or cushioning material is damaged, keep them until you have checked the contents of the shipment and checked the instrument mechanically and electrically.

### 2 Check the supplied accessories.

Accessories supplied with the module are listed in "Accessories" in chapter 1.

### 3 Inspect the product for physical damage.

Check the module and the supplied accessories for obvious physical or mechanical defects. If you find any defects, contact your nearest Hewlett-Packard Sales Office. Arrangements for repair or replacement are made, at Hewlett-Packard's option, without waiting for a claim settlement.

---

## To Prepare the Mainframe

---

### CAUTION

Turn off the mainframe power before removing, replacing, or installing the module.

---

### CAUTION

Electrostatic discharge can damage electronic components. Use grounded wriststraps and mats when performing any service to this module.

### 1 Turn off the mainframe power switch, then unplug the power cord. Disconnect any input or output connections.

### 2 Plan your module configuration.

If you are installing a one-card module, use any available slot in the mainframe.

If you are installing a multi-card module, use adjacent slots in the mainframe. See illustration on next page for combinations.

### 3 Loosen the thumb screws.

Cards or filler panels below the slots intended for installation do not have to be removed.

Starting from the top, loosen the thumb screws on filler panels and cards that need to be moved.

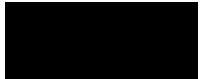

## Installation and Service To Prepare the Mainframe

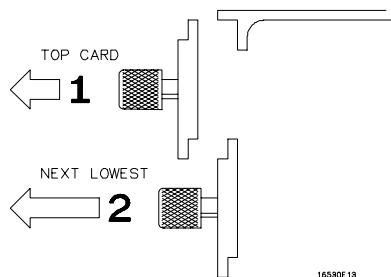

**4** Starting from the top, pull the cards and filler panels that need to be moved halfway out.

**CAUTION**

All multi-card modules will be cabled together. Pull these cards out together to prevent damage to the cables and connectors.

**5** Remove the cards and filler panels.

Remove the cards or filler panels that are in the slots intended for the module installation. Push all other cards into the card cage, but not completely in. This is to get them out of the way for installing the module.

Some modules for the Logic Analysis System require calibration if you move them to a different slot. For calibration information, refer to the manuals for the individual modules.

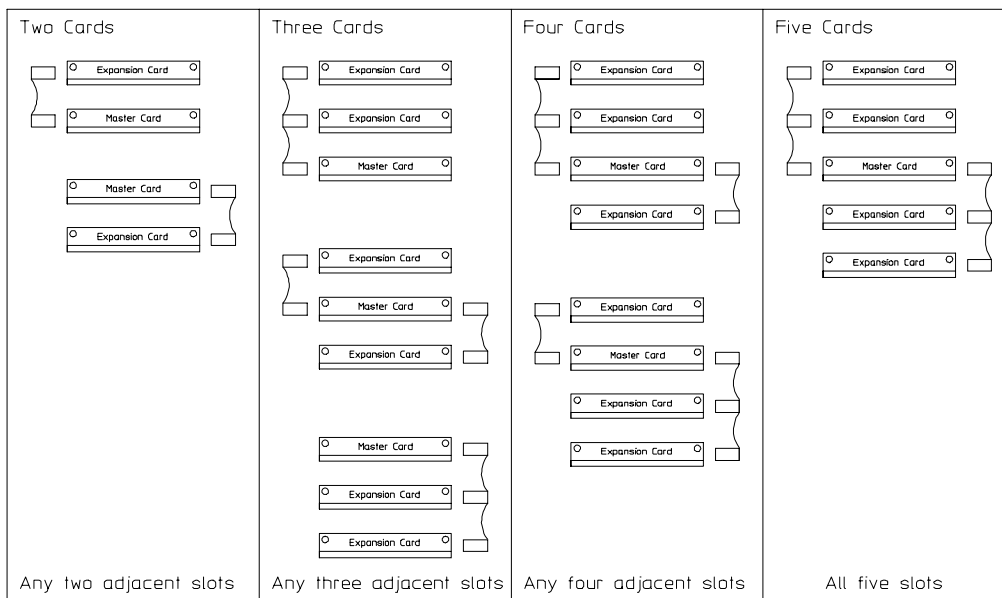

16517N01

---

## To Configure a One-card Module

- The HP 16517A module can be used as a one-card module. The HP 16518A module can not be used as a one-card module.
- If you need to configure a multi-card module into a one-card module, remove the cables connecting the cards.
- 

---

## To Configure a Multi-card Module

To configure a multi-card module, connect the cables as follows:

Save unused cables for future configurations.

- To configure a two-card module, use the short cable to connect the HP 16517A Master Card to the HP 16518A Expansion Card. The master card can be above or below the expansion card. Note that if the master card is below, the connector on the left side of the master card (when looking at back of mainframe) must be used; when the master card is above the expansion card, the connector on the right side of the master card must be used. See "To Install the Module" for the installation procedure.
- To configure a three-card module, you can have the master card in between the expansion cards, or above or below the expansion cards (see illustration on page 13-4). Note the cables which are used for each configuration, and the side of the master card which is used for connecting. If the master card is below, the connector on the left side of the master card (when looking at back of mainframe) must be used; when the master card is above the expansion card, the connector on the right side of the master card must be used. See "To Install the Module" for the installation procedure.

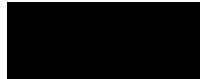

- To configure a four-card module, you can have one expansion card above the master card and two below, or two expansion cards above and one below (see illustration on page 13-4). Note the cables which are used for each configuration, and the side of the master card which is used for connecting. If the master card is below the expansion card, the connector on the left side of the master card (when looking at back of mainframe) must be used; when the master card is above the expansion card, the connector on the right side of the master card must be used. See "To Install the Module" for the installation procedure.
- To configure a five-card module, the master card must go in the middle slot, and two expansions cards are above it and two are below it (see illustration on page 13-4). The two long cables (three connectors) must be used. For the expansion cards above the master card, use the connector on the left side of the master card (when looking at back of mainframe); for the expansion cards below the master card, the connector on the right side of the master card must be used. See "To Install the Module" for the installation procedure.

---

## To Install the Module

- 1 Slide the cards above the slots for the module about halfway out of the mainframe.
- 2 If the module consists of a single card, then slide the module approximately halfway into the mainframe.

If the module consists of more than one card, then perform the following steps:

- a Slide the card approximately three inches into the mainframe.
- b Connect the appropriate interface cable (long or short) to the appropriate side of the card (see illustration on page 13-4). Repeat steps a and b for the remaining cards.

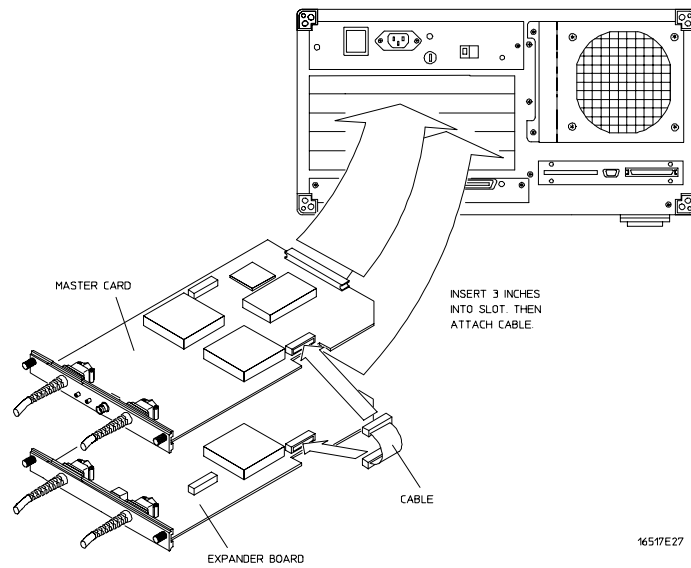

- 3 Slide the complete module into the mainframe, but not completely in. Each card in the instrument is firmly seated and tightened one at a time in step 5.
- 4 Position all cards and filler panels so that the endplates overlap.



**5 Seat the cards and tighten the thumbscrews.**

Starting with the bottom card, firmly seat the cards into the backplane connector of the mainframe. Keep applying pressure to the center of the card endplate while tightening the thumbscrews finger-tight. Repeat this for all cards and filler panels starting at the bottom and moving to the top.

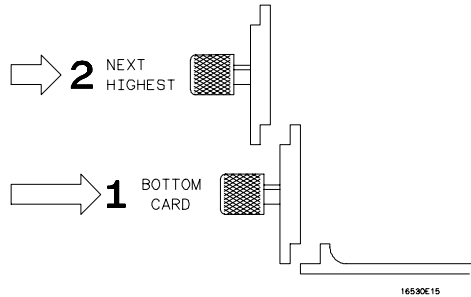

---

**WARNING**

---

For correct air circulation, filler panels must be installed in all unused card slots. Correct air circulation keeps the instrument from overheating. Keep any extra filler panels for future use.

---

**To Test the Module**

- If you require a test to initially accept the operation, perform the self-tests later in this chapter.
- If you need to deskew the channel-to-channel variations, go to chapter 10, "Skew Adjust."
- If you require a test to verify the specifications, start at the beginning of chapter 3, "Testing Performance," in the optional *HP 16517A/18A Service Guide*. The Service Guide is available through your HP Sales Office.
- If the module does not operate correctly, go to the beginning of chapter 5, "Troubleshooting," in the optional *HP 16517A/18A Service Guide*. The Service Guide is available through your HP Sales Office.

---

## To Perform the Self-tests

The self-tests verify the correct operation of the module. Self-tests can be performed all at once or one at a time. While testing the performance of the module, run the self-tests all at once.

If error messages appear during the self-tests, refer to chapter 11 for a description of the message.

Loading the PV (performance verification) operating system will overwrite all of the HP 16500-series module configurations. If you would like to keep the configurations, then save the configurations to disk prior to loading the PV system. Refer to the *HP 16500/16501A User's Reference* for more information on saving configuration files to disk.

---

### Access the Self-tests

- 1 Disconnect all inputs, then turn on the power switch if the mainframe is not turned on.
- 2 In the System Configuration menu, touch Configuration. In the pop-up menu, touch Test.

If the HP 16517A/18A module is configured in an HP 16500A mainframe, the PV system disk must be installed in one of the flexible disk drives.

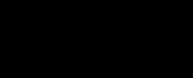
- 3 Touch the box labeled Touch Box to Load Test System.
  - 4 On the test system screen, touch Test System. At the pop-up menu, select 4GHz/1GHz Timing.
- 

---

## Perform the Functional Tests

The Functional Tests verify the main subsystems of the HP 16517A/18A module are functioning. The pod channels are not connected to any type of test signal for any of these tests. If a test fails, a message will appear which indicates which module board failed. Refer to chapter 8 for a description of the error messages.

- 1 Touch Functional Tests. The functional tests menu appears.

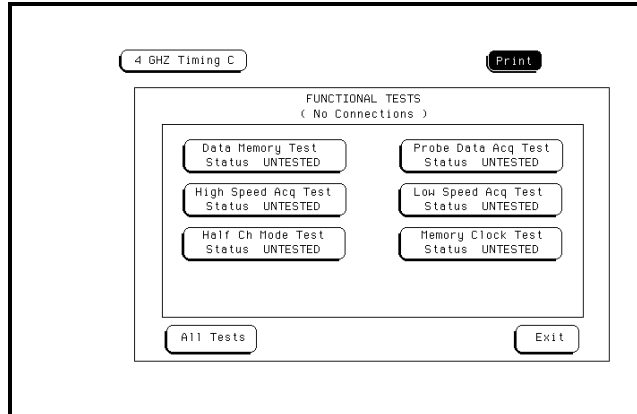

- 2 To run all of the tests, touch the All Tests field. As each of the functional tests is performed and passed, the status field will change from UNTESTED to PASS.
- 3 Touch Done to exit the test menu. Touch Exit to exit the Functional Tests menu.



---

## Perform the Skew Adjustments and Tests

Valid skew factors must be present in order to access these tests. The Skew Tests require valid skew factors to ensure that the tests will pass.

### 1 Touch Skew Adjustments and Tests.

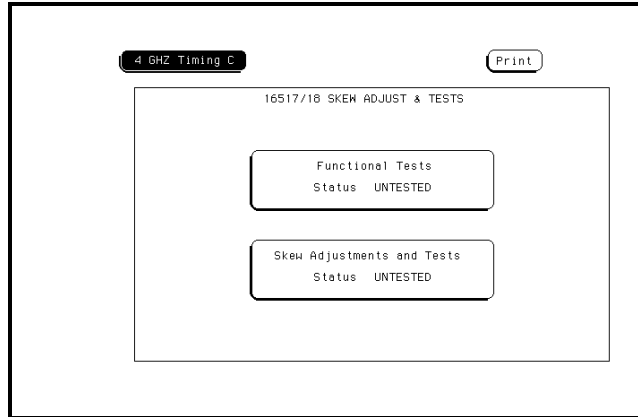

- 2 Perform the skew adjust procedure. Touch Adjust Clock and Data Path Skew. A BNC coax cable (HP 10503A) and Calibration Pod (16517-63201) are needed. Follow the instructions on the display. At the end of the Skew adjust, save the skew factors to NV-RAM. For more information, refer to "To Adjust the Channel-to-channel Skew" in chapter 10.

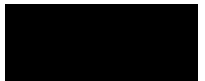
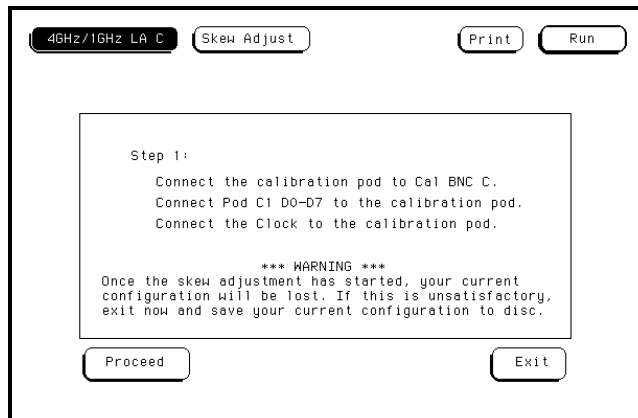

- 3 To run all of the tests, touch the All Tests field. As each of the skew-dependent tests are performed and pass, the status field will change from UNTESTED to PASS.
- 4 Touch Done to exit the test menu. Touch Exit to exit the Skew Adjustments and Tests menu.

---

### Exit the Self-tests

- 1 Touch the 4GHz/1GHz Timing field, then touch Test System.
- 2 Touch Configuration, then touch Test.

If the HP 16517A/18A module is configured in an HP 16500A mainframe, the operating system disk must be installed in one of the flexible disk drives.

- 3 Touch the box labeled Touch box to Exit Test System. The HP 16500 operating system will now load and the system configuration menu will appear.

---

## To Return Assemblies

Before shipping the module to Hewlett-Packard, contact your nearest Hewlett-Packard Sales Office for additional details.

**1 Write the following information on a tag and attach it to the module.**

- Name and address of owner
- Model number
- Serial number
- Description of service required or failure indications

**2 Remove accessories from the module.**

Only return accessories to Hewlett-Packard if they are associated with the failure symptoms.

**3 Package the module.**

You can use either the original shipping containers, or order materials from an HP sales office.

---

**CAUTION**

---

Electrostatic discharge can damage electronic components. For protection against electrostatic discharge, package the module in electrostatic material.

**4 Seal the shipping container securely, and mark it FRAGILE.**

---

## To Clean the Logic Analyzer Module

With the instrument turned off and unplugged, use mild soap and water to clean the front of the module. Harsh soap might damage the water-based paint.





○ field greater than, 4-21

## A

### accessories

available, 1-6  
supplied, 1-6  
accumulate field, 6-4  
acquisition control  
mode types, 4-32  
sample period, 4-34  
samples/clocks, 4-34 to 4-36  
trigger position, 4-33  
acquisition control field, 6-3  
acquisition mode, 4-32  
activity indicators, 3-12  
adapter

BNC to SMB, 2-8  
adjusting skew, 10-2  
advisory messages, 11-7  
analyzer

accessories available, 1-6  
accessories supplied, 1-6  
configuration capabilities, 1-5  
description, 1-2  
user interface, 1-4

analyzer type considerations  
state, 2-iii

timing, 2-iii  
armed by field, 4-37

## B

base field, 4-31  
bit assignment, 3-10 to 3-11  
bit editing field, 7-15  
bit patterns, 4-19  
blue bar field, 6-12 to 6-13  
branching, 4-24  
bus interfaces, 2-3

## C

calibration, 10-2  
calibration pod, 2-8  
center screen field, 9-7  
channel masking, 7-10  
channel-to-channel skew, 10-2  
Chart menu, 8-2  
find x-pattern/o-pattern field, 9-5  
from trigger/start/x-marker field, 9-6  
markers field, 8-5, 9-3

post-processing features, 8-2  
x-axis label/state value field, 8-9

### charts

label value vs label value, 8-3  
label value vs states, 8-3

cleaning, 13-13

clear pattern field, 9-11

compare full/compare partial field, 7-9

compare image, 7-4

Compare menu, 7-2

bit editing field, 7-15

compare full/compare partial field, 7-9

copy listing to reference field, 7-7

data roll field, 7-14

difference listing field, 7-5 to 7-6

find error field, 7-8

label and base fields, 7-16

mask field, 7-10

post-processing features, 7-3

reference listing field, 7-4

specify stop measurement, 7-11 to 7-13

configuration capabilities, 1-5

configuring the analyzer, 1-5

copy listing to reference field, 7-7

cursor, 1-4

## D

data roll field, 5-3, 7-14

delay field

negative/positive, 6-6

description

accessories supplied, 1-6

difference listing field, 7-5 to 7-6

display location reference line, 6-10

duration

pattern, 4-20

## E

edges, 4-19

error messages, 11-3

example, 3-7

external clock display, 6-7

## F

find error field, 7-8

find X-pattern/O-pattern, 9-5

Format menu, 3-2

bit assignment fields, 3-10 to 3-11

label polarity fields, 3-9

menu map, 3-3

pod threshold field, 3-8

state acquisition mode field, 3-3

timing acquisition mode field, 3-4

from trigger/start/X-marker field, 9-6

## I

### interfaces

Ethernet, 1-2

HP-IB, 1-2

preprocessor, 2-3

probing, 2-3

RS-232-C, 1-2

user, 1-4

## K

keyboard, 1-4

knob, 1-4

## L

label polarity fields, 3-9

labels assignment, 4-31

labels field, 4-31

Listing menu, 5-2

clear pattern field, 9-11

data roll field, 5-3

find x-pattern/o-pattern field, 9-5

from trigger/start/x-marker field, 9-6

label and base fields, 5-4, 9-9

markers field, 5-3, 9-3

pattern display field, 9-9

specify patterns field, 9-8 to 9-9

stop measurement field, 9-10

trig to x/trig to o fields, 9-13

x and o entering/leaving fields, 9-8

x to o display field, 9-13

logic analyzer

description, 1-2

## M

macros, 4-9

definition, 4-9

state, 4-15 to 4-16

timing, 4-12 to 4-14

using, 4-11

marker label/base and display, 9-13

markers, 9-2

chart menu, 8-4



- 
- pattern markers, 9-4
  - statistics markers, 9-14
  - time markers, 9-12
  - waveform menu, 6-8
  - markers field, 5-3, 6-8, 8-5, 9-3
  - mask field, 7-10
  - modify trigger field, 4-6 to 4-8, 4-10
  - mouse, 1-4
- N**
- negative delay, 6-6
- O**
- occurrence counters, 4-23
  - occurrence field, 9-5, 9-7
  - oversampling
    - samples/clocks field, 4-34
- P**
- pattern durations, 4-20
  - pattern markers, 9-4
  - pattern occurrence field, 9-7
  - pattern occurrence fields, 9-5
  - plot from State, 8-9
  - pod threshold
    - levels, 3-8
  - pod threshold field, 3-8
  - polarity, 3-9
  - post-processing features
    - chart menu, 8-2
    - compare menu, 7-3
  - pre-defined sequence type, 4-9
  - probing
    - accessories, 2-6 to 2-8
    - bus, 2-3
    - considerations, 2-9
    - description, 2-4 to 2-5
    - general purpose, 2-2
    - ground leads, 2-6
    - interface to target map, 2-10 to 2-11
    - microprocessor, 2-3
    - options, 2-2
    - signal leads, 2-7
    - user-definable interface, 2-3
    - using preprocessors, 2-3
  - probing options
    - E2445A User-Definable Interface, 2-3
- R**
- reference listing field, 7-4
  - reset statistics, 6-20, 9-15
  - resource terms, 4-25
    - assigning bit pattern values, 4-28
    - assigning combinations, 4-29
    - assigning custom names, 4-27 to 4-30
    - assigning edges, 4-28
    - assigning timers, 4-29
    - bit patterns, 4-25 to 4-26
    - edges, 4-25 to 4-26
    - timers/counters, 4-26
- S**
- sample offset, 3-6 to 3-7
  - sample period, 4-34
  - sample period display, 6-7
  - samples/clocks field, 4-34 to 4-36
  - seconds per division field, 6-5
  - select clock field, 3-5
  - selecting waveforms
    - blue bar field, 6-12 to 6-13
    - channel mode field, 6-14 to 6-15
    - insert/delete, 6-17
    - module and label fields, 6-16
    - sequential/individual/overlay, 6-14
    - waveform display size, 6-19
  - selecting waveforms
    - delete and delete all fields, 6-18
  - sequence levels
    - branching, 4-24
    - definition, 4-4
    - editing, 4-5
    - types, 4-4
    - user-programmable, 4-17 to 4-24, 4-26
  - set sample offset field, 3-6 to 3-7
  - show states field, 5-5
  - skew adjust, 10-2
  - specifications, 12-2
  - specify patterns field, 9-8 to 9-9
  - specify stop measurement, 7-11 to 7-13
    - compare, 7-12
    - x - o, 7-13
  - state acquisition mode
    - full channel 64K memory, 3-3
  - state data in timing waveform display, 6-15
  - statistics
    - clear statistics, 9-15
    - reset statistics, 6-20, 9-15
    - statistics markers, 9-14
  - stop measurement, 9-2
  - stop measurement field, 9-10
    - compare, 9-11
    - x - o, 9-10
  - symbols assignment, 3-12
- T**
- template, 7-4
  - time markers, 9-12
  - timers, 4-22
  - timing acquisition mode, 3-4
  - timing mode
    - full channel, 3-4
    - half channel, 3-4
  - touchscreen, 1-4
  - trig to X/trig to O fields, 9-13
  - trigger macros, 4-9
  - trigger position, 4-33
  - trigger sequence level types, 4-4
  - trigger sequence levels, 4-4
- U**
- user definable interface, 2-3
  - user interface, 1-4
  - User's Reference, 2-iii
- W**
- warning messages, 11-4 to 11-6
  - waveform display, 6-9
  - Waveform menu, 6-2
    - accumulate field, 6-4
    - acquisition control field, 6-3
    - blue bar field, 6-12 to 6-13
    - center screen field, 9-7
    - delay field, 6-6
    - external clock display, 6-7
    - find x-pattern/find o-pattern, 9-5
    - from trigger/start/x-marker field, 9-6
    - marker label/base and display, 9-13
    - markers field, 6-8, 9-3
    - sample period display, 6-7
    - seconds per division field, 6-5
    - waveform display, 6-9
-

---

X to O display field, 9-7  
x-pattern/o-pattern occurrence field, 9-7  
waveform reconstruction, 6-7  
waveform size, 6-19

**X**

X to O display field, 9-13  
X to O field, 9-7  
X-axis label/state value field, 8-9



---

Index-4



© Copyright Hewlett-Packard Company 1987, 1990, 1993, 1996, 1997, 1999 All Rights Reserved.

Reproduction, adaptation, or translation without prior written permission is prohibited, except as allowed under the copyright laws.

#### Document Warranty

The information contained in this document is subject to change without notice.

**Hewlett-Packard makes no warranty of any kind with regard to this material, including, but not limited to, the implied warranties or merchantability and fitness for a particular purpose.**

Hewlett-Packard shall not be liable for errors contained herein or for incidental or consequential damages in connection with the furnishing, performance, or use of this material.

Complete product warranty information is given on the last page of this guide.

#### Safety

This apparatus has been designed and tested in accordance with IEC Publication 348, Safety Requirements for Measuring Apparatus, and has been supplied in a safe condition. This is a Safety Class I instrument (provided with terminal for protective earthing). Before applying power, verify that the correct safety precautions are taken (see the following warnings). In addition, note the external markings on the instrument that are described under "Safety Symbols."

#### Warning

- Before turning on the instrument, you must connect the protective earth terminal of the instrument to the protective conductor of the (mains) power cord. The mains plug shall only be inserted in a socket outlet provided with a protective earth contact. You must not negate the protective action by using an extension cord (power cable) without a protective conductor (grounding). Grounding one conductor of a two-conductor outlet is not sufficient protection.
- Only fuses with the required rated current, voltage, and specified type (normal blow, time delay, etc.) should be used. Do not use repaired fuses or short-circuited fuseholders. To do so could cause a shock of fire hazard.

- Service instructions are for trained service personnel. To avoid dangerous electric shock, do not perform any service unless qualified to do so. Do not attempt internal service or adjustment unless another person, capable of rendering first aid and resuscitation, is present.

- If you energize this instrument by an auto transformer (for voltage reduction), make sure the common terminal is connected to the earth terminal of the power source.
- Whenever it is likely that the ground protection is impaired, you must make the instrument inoperative and secure it against any unintended operation.
- Do not operate the instrument in the presence of flammable gasses or fumes. Operation of any electrical instrument in such an environment constitutes a definite safety hazard.
- Do not install substitute parts or perform any unauthorized modification to the instrument.
- Capacitors inside the instrument may retain a charge even if the instrument is disconnected from its source of supply.
- Use caution when exposing or handling the CRT. Handling or replacing the CRT shall be done only by qualified maintenance personnel.

#### Safety Symbols



Instruction manual symbol: the product is marked with this symbol when it is necessary for you to refer to the instruction manual in order to protect against damage to the product.



Hazardous voltage symbol.



Earth terminal symbol: Used to indicate a circuit common connected to grounded chassis.

#### WARNING

The Warning sign denotes a hazard. It calls attention to a procedure, practice, or the like, which, if not correctly performed or adhered to, could result in personal injury. Do not proceed beyond a Warning sign until the indicated conditions are fully understood and met.

#### CAUTION

The Caution sign denotes a hazard. It calls attention to an operating procedure, practice, or the like, which, if not correctly performed or adhered to, could result in damage to or destruction of part or all of the product. Do not proceed beyond a Caution symbol until the indicated conditions are fully understood or met.

---

Hewlett-Packard  
P.O. Box 2197  
1900 Garden of the Gods Road  
Colorado Springs, CO 80901

---

### **Product Warranty**

This Hewlett-Packard product has a warranty against defects in material and workmanship for a period of one year from date of shipment. Some newly manufactured products may contain remanufactured parts which are equivalent to new in performance. During the warranty period, Hewlett-Packard Company will, at its option, either repair or replace products that prove to be defective. For warranty service or repair, this product must be returned to a service facility designated by Hewlett-Packard.

For products returned to Hewlett-Packard for warranty service, the Buyer shall prepay shipping charges to Hewlett-Packard and Hewlett-Packard shall pay shipping charges to return the product to the Buyer. However, the Buyer shall pay all shipping charges, duties, and taxes for products returned to Hewlett-Packard from another country.

Hewlett-Packard warrants that its software and firmware designated by Hewlett-Packard for use with an instrument will execute its programming instructions when properly installed on that instrument. Hewlett-Packard does not warrant that the operation of the instrument software, or firmware will be uninterrupted or error free.

### **Limitation of Warranty**

The foregoing warranty shall not apply to defects resulting from improper or inadequate maintenance by the Buyer, Buyer-supplied software or interfacing, unauthorized modification or misuse, operation outside of the environmental specifications for the product, or improper

site preparation or maintenance.

No other warranty is expressed or implied. Hewlett-Packard specifically disclaims the implied warranties or merchantability and fitness for a particular purpose.

### **Exclusive Remedies**

The remedies provided herein are the buyer's sole and exclusive remedies. Hewlett-Packard shall not be liable for any direct, indirect, special, incidental, or consequential damages, whether based on contract, tort, or any other legal theory.

### **Assistance**

Product maintenance agreements and other customer assistance agreements are available for Hewlett-Packard products. For any assistance, contact your nearest Hewlett-Packard Sales Office.

### **Certification**

Hewlett-Packard Company certifies that this product met its published specifications at the time of shipment from the factory. Hewlett-Packard further certifies that its calibration measurements are traceable to the United States National Institute of Standards and Technology, to the extent allowed by the Institute's calibration facility, and to the calibration facilities of other International Standards Organization members.

### **About this edition**

This is the *HP 16517A/18A Logic Analyzer User's Reference*

Publication number  
16517-97006, January 1999  
Printed in USA.

Print history is as follows:

16517-97005, August 1997  
16517-97003, November 1996

New editions are complete revisions of the manual. Many product updates do not require manual changes and manual corrections may be done without accompanying product changes. Therefore, do not expect a one-to-one correspondence between product updates and manual updates.

# DECLARATION OF CONFORMITY

according to ISO/IEC Guide 22 and EN 45014

**Manufacturer's Name:** Hewlett-Packard Company

**Manufacturer's Address:** Colorado Springs Division  
1900 Garden of the Gods Road  
Colorado Springs, CO 80907 USA

declares that the product

**Product Name:** Logic Analyzer Module

**Model Number(s):** HP 16517A and 16518A

**Product Option(s):** All

conforms to the following Product Specifications:

**Safety:** IEC 348:1978 / HD 401 S1:1981  
UL 1244  
CSA-C22.2 No. 231 (Series M-89)

**EMC:** CISPR 11:1990 / EN 55011:1991 Group 1 Class A  
IEC 555-2:1982 + A1:1985 / EN 60555-2:1987  
IEC 555-3:1982 + A1:1990 / EN 60555-3:1987 + A1:1991  
IEC 801-2:1991 / EN 50082-1:1992 4 kV CD, 8 kV AD  
IEC 801-3:1984 / EN 50082-1:1992 3 V/m, {1kHz 80% AM, 27-1000 MHz}  
IEC 801-4:1988 / EN 50082-1:1992 0.5 kV Sig. Lines, 1 kV Power Lines

## Supplementary Information:

The product herewith complies with the requirements of the Low Voltage Directive 73/23/EEC and the EMC Directive 89/336/EEC and carries the CE marking accordingly.

This product was tested in a typical configuration with Hewlett-Packard test systems.

Colorado Springs, 03/02/93

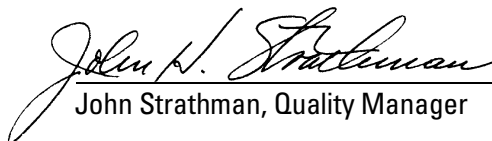
  
John Strathman, Quality Manager

European Contact: Your local Hewlett-Packard Sales and Service Office or Hewlett-Packard GmbH, Department ZQ / Standards Europe, Herrenberger Strasse 130, D-71034 Böblingen Germany (FAX: +49-7031-14-3143)

## Product Regulations

**Safety** IEC 348:1978 / HD 401 S1:1981  
UL 1244  
CSA-C22.2 No.231 (Series M-89)

**EMC** This Product meets the requirement of the European Communities (EC)  
EMC Directive 89/336/EEC.



**Emissions** EN55011/CISPR 11 (ISM, Group 1, Class A equipment)

<b>Immunity</b>	EN50082-1	Code <sup>1</sup>	Notes <sup>2</sup>
	IEC 555-2	1	
	IEC 555-3	1	
	IEC 801-2 (ESD) 4kV CD, 8kV AD	2	
	IEC 801-3 (Rad.) 3 V/m	1	
	IEC 801-4 (EFT) 0.5 kV, 1kV	1	

<sup>1</sup> Performance Codes:

- 1 PASS - Normal operation, no effect.
- 2 PASS - Temporary degradation, self recoverable.
- 3 PASS - Temporary degradation, operator intervention required.
- 4 FAIL - Not recoverable, component damage.

<sup>2</sup> Notes: (none)

**Sound Pressure Level** N/A