

**PREAMP
10855A**

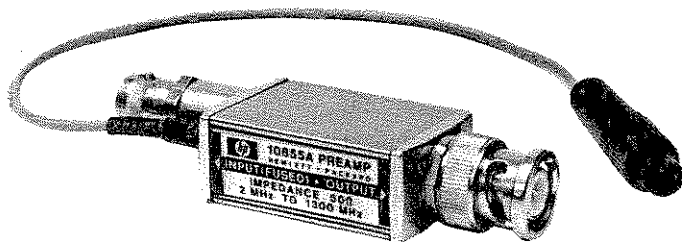

 **HEWLETT
PACKARD**

PREAMP

10855A

OPERATING AND SERVICE MANUAL

Printed: JULY 1976

Copyright HEWLETT-PACKARD COMPANY 1976
5301 STEVENS CREEK BLVD., SANTA CLARA, CALIF. 95050

MANUAL PART NO. 10855-90001

PRINTED IN U.S.A.



TABLE OF CONTENTS

Title	Page
Description	1
Date Code	1
Initial Inspection	1
Power Requirements	2
Operating Instructions	2
Operator Maintenance	2
Repair	3

LIST OF TABLES

Table	Page
1 Specifications	1
2 10855A Replaceable Parts	7

LIST OF FIGURES

Figure	Page
1A Flatness Test Setup	5
1B VSWR Test Setup	5

DESCRIPTION

The Hewlett-Packard Model 10855A Preamplifier provides a minimum of 22 dB gain for low level signals in the range of 2 MHz to 1300 MHz. The preamp can be used with a variety of HP measuring instruments having probe power connectors or may be used with a separate power supply. It can be used with frequency counters, spectrum analyzers, network analyzers, sampling scopes, and other similar devices within its frequency range.

DATE CODE

The preamp's year and week of manufacture are stamped on the inside of the unit. Example 6-24 would be the 24th week of 1976. Production changes to the preamp are identified by date code. This manual applies to all date codes unless accompanied by a change sheet.

INITIAL INSPECTION

If damage to the shipping carton is evident, ask the carrier's agent to be present when the instrument is unpacked.

Table 1. Specifications

Frequency range: 2 MHz — 1300 MHz
3 dB Bandwidth: 1 MHz — 1400 MHz, typical
Gain (minimum): 22 dB; 24 dB typical
Gain flatness across full frequency range: ± 1 dB
Noise figure: <8.5 dB typical
Output power for 1 dB gain compression: 0 dBm
Harmonic distortion: -30 dB for -15 dBm output, typical
Output for <-60 dB harmonic distortion: -25 dBm, typical
VSWR: Input and output, <2.2
Impedance: 50 Ω nominal
Reverse isolation: >45 dB
Maximum Input: 3.5V rms (+24 dBm), fuse protected
GENERAL
Current required at +15V supply: 40 mA (mating connector included)
Weight: net, 0.03 kg (1 ounce); shipping, 0.1 kg (7 ounces)
Dimensions: 80 mm long (3-1/8"), 25 mm high (1"), 15 mm wide (9/16")

Inspect the instrument for mechanical damage. If damage is evident, notify the carrier and the nearest Hewlett-Packard field office immediately. The field office will arrange for replacement or repair of your instrument without delay for claim settlements against the carrier.

POWER REQUIREMENTS

The 10855A requires +15 volts at 40 milliamps. Some HP instruments are equipped with a mating front panel connector. For other instruments, a mating connector (HP Part Number 5060-0467) is supplied. Wire the connector as follows:

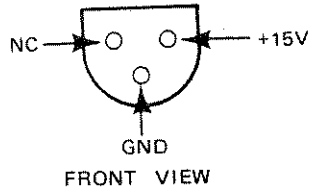

NOTE: The GND pin is connected to the 10855A case, thus to the BNC connector's outer case. Be careful when connecting to floating power supplies.

If a separate power supply is desired, the HP 1122A Probe Power Supply is available.

OPERATING INSTRUCTIONS

- a. Connect power lead to +15 volt receptacle.

CAUTION

Do not apply more than +24 dBm to the input: the protective fuse will blow.

- b. Attach input and output cables.

OPERATOR MAINTENANCE

The input fuse (.125 amp, 125V) is replaced by unscrewing the input BNC connector and installing a new fuse (HP Part Number 2110-0301). Use a BNC connector as a wrench to remove and tighten the fuse jack.

REPAIR

Cover Removal is accomplished by applying pressure to cover edges. Note that the internal RF shield's crease contacts the IC when reinstalling the cover.

Repair. Figure 2 shows the schematic diagram and Table 2 lists the replaceable parts for the 10855A. Specifications in Table 1 should be checked using standard procedures. Figure 1 shows a test setup for checking flatness and VSWR.

C4 is selected for minimum VSWR and R1 is selected for the flatness specification.

Except for CR1, CR2 and R1, replacing parts requires microwave repair techniques. The small microchip capacitors should only be replaced by qualified microwave technicians with the proper equipment.

Figure 1A. Flatness Test Setup

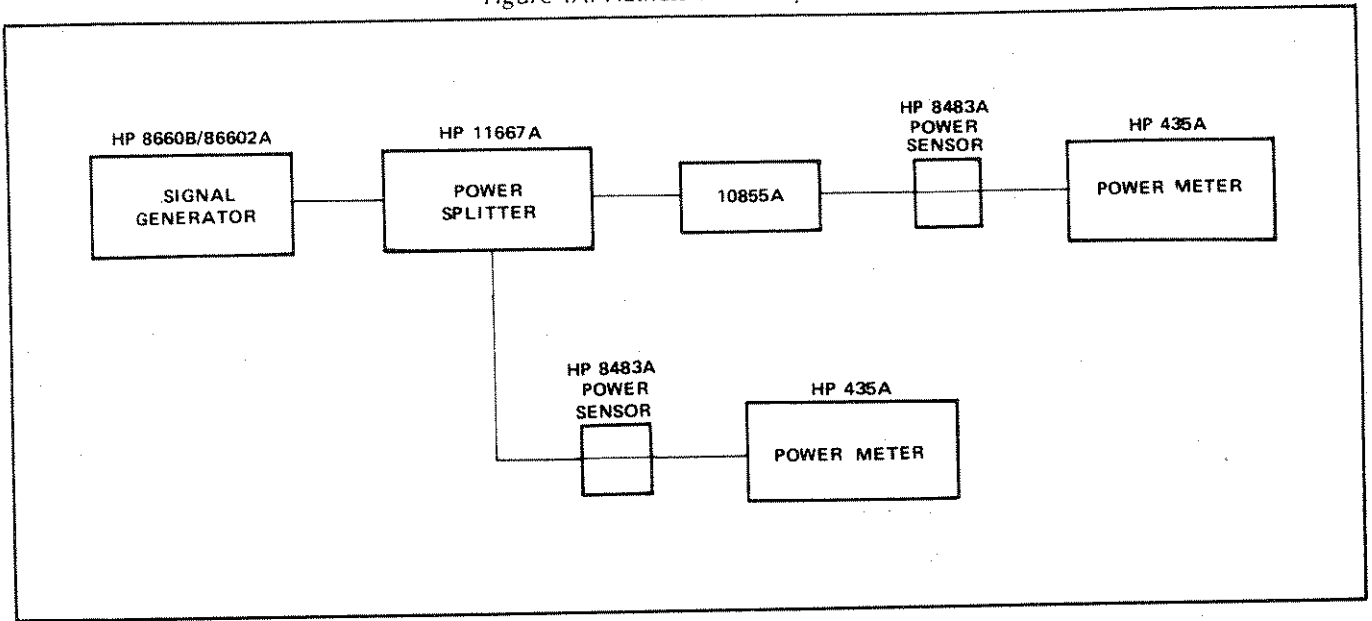

Figure 1B. VSWR Test Setup

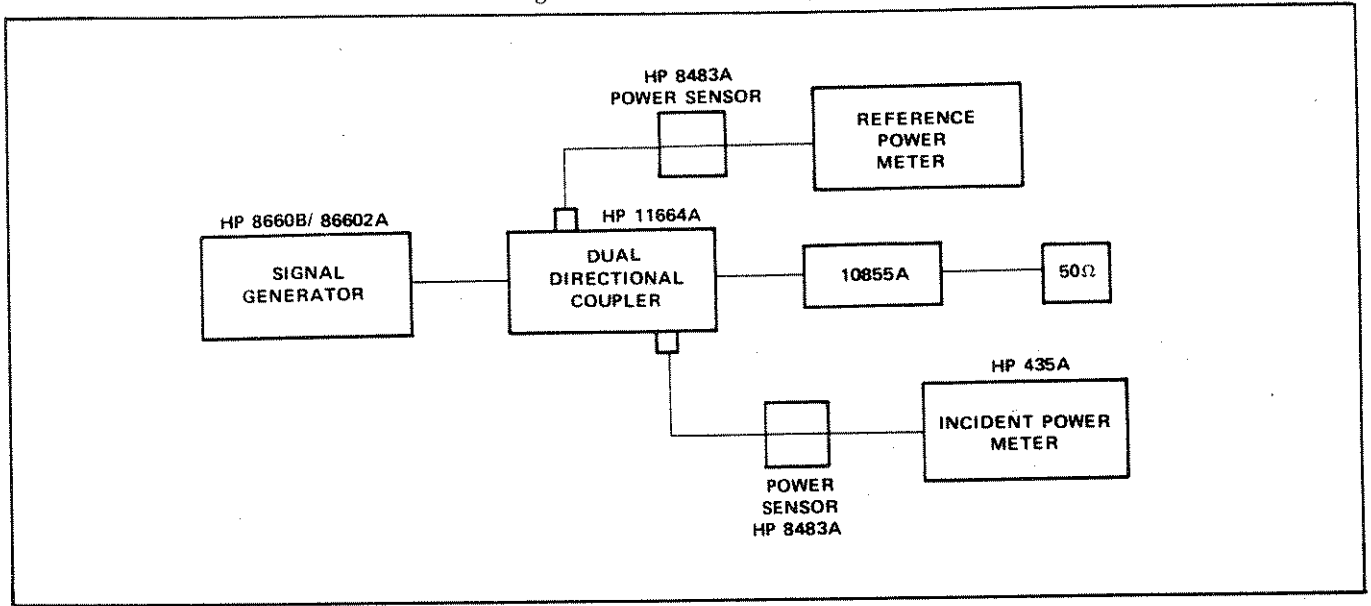

Table 2. 10855A Replaceable Parts

Ref. Desig.	HP Part No.	Qty.	Description	Mfr Code	Mfr Part No.
C1	0160-4241	2	CAPACITOR-FXD .012 UF +-10% 50WVDC CER	26654	3BX050S123K(D)
C2	0160-4241		CAPACITOR-FXD .012 UF +-10% 50WVDC CER	26654	3BX050S123K(D)
C3	0160-3878	1	CAPACITOR-FXD 1000 PF +-20% 100WVDC CER	28480	0160-3878
C4*	0160-4445	1	CAPACITOR-FXD 1.5PF +-10% 50WVDC CER	28480	0160-4445
C4*	None		May be omitted to set VSWR		
CR1	1901-0050	2	DIODE SWITCHING 80V 200MA 2NS DO-7	28480	1901-0050
CR2	1901-0050		DIODE SWITCHING 80V 200MA 2NS DO-7	28480	1901-0050
F1	2110-0301	1	FUSE .125A 125V FAST-BLO .281 x .093	75915	275.125
J1	05305-60205	1	CONNECTOR-ASSY-BNC	28480	05305-60205
J2	1250-1233	1	CONNECTOR-RF BNC M SGL HOLE FR	28480	1250-1233
P1 (Part of W1)	-----	1	CONNECTOR: FEMALE, probe power Order entire cable assy W1 for replacement		
R1*	0683-7505	1	RESISTOR 75 OHM 5% .25W FC TC =-400/+500	01121	CB7505
R1*	0683-8205	1	RESISTOR 82 OHM 5% .25W FC TC =-400/+500	01121	CB8205
R1*	0683-9105	1	RESISTOR 91 OHM 5% .25W FC TC =-400+500	01121	CB9105

Table 2. 10855A Replaceable Parts (Cont'd)

Ref. Desig.	HP Part No.	Qty.	Description	Mfr Code	Mfr Part No.
U1	5088-7017	1	1.3 GHz AMPLIFIER	28480	5088-7017
XF1	10855-20203	1	HOLDER-FUSE	28480	10855-20203
	05305-00010	1	CLAMP-GROUNDING	28480	05305-00010
	10855-00001	1	STRAP-GROUND	28480	10855-00001
	10855-20201	1	CHASSIS	28480	10855-20201
	10855-20202	1	COVER	28480	10855-20202
W1	10855-60100	1	CABLE ASSEMBLY	28480	10855-60100
	5060-0467	1	CONNECTOR: MALE PROBE POWER (Supplied as mating connector for P1)	28480	5060-0467

*Factory selected

Figure 2. 10855A Schematic Diagram

