

INSTRUCTION MANUAL

TYPE 1382

RANDOM-NOISE GENERATOR

20 Hz - 50 kHz

Form No. 1382-0100-A
ID No. 2495
April, 1968

NOTE: This instrument is equipped with our new snap-on knob for added convenience and safety. Refer to the Service Section for details.

Copyright 1968 by General Radio Company
West Concord, Massachusetts, USA

GENERAL RADIO COMPANY
WEST CONCORD, MASSACHUSETTS, USA

Specifications

Spectrum: Either (a) "White" noise (constant energy per cycle bandwidth) ± 1 dB from 20 Hz to 20 kHz, with 3-dB-down points at 10 Hz, approximately, and 50 kHz; (b) "Pink" noise (constant energy per octave bandwidth) ± 1 dB from 20 Hz to 20 kHz; or (c) "USASI" noise, for calibrating sound-level meters, as specified in USASI Standard S1.4.

Waveform: Table below shows values of Gaussian probability density function and specifications on amplitude density distribution of the noise generator, as measured in a "window" of 0.2σ , centered on the indicated values:

Voltage	Gaussian Prob. Dens. Function	Amplitude Density Dist. of 1381 Random-Noise Gen.
0	0.0796	0.0796 ± 0.005
$\pm\sigma$	0.0484	0.0484 ± 0.005
$\pm 2\sigma$	0.0108	0.0108 ± 0.003
$\pm 3\sigma$	0.000898	0.000898 ± 0.0002 <i>.0002% of the time</i>
$\pm 4\sigma$	0.0000274	0.0000274 ± 0.00002 <i>.002%</i>

σ is the standard deviation or rms value of the noise voltage.

Output Voltage: Maximum open-circuit output voltage is at least 3V, rms, for any bandwidth.

Output Impedance: 600 ohms, balanced or unbalanced. Output may be shorted without causing distortion.

Amplitude Control: Output amplitude is continuously adjustable from full output to approximately 60 dB below that level.

Power Required: 6W at 100 to 125 V, or 200 to 250 V, 50 to 400 Hz.

Mechanical Data:

MODEL	WIDTH		HEIGHT		DEPTH		NET WEIGHT		SHIPPING WEIGHT	
	in.	mm	in.	mm	in.	mm	lb	kg	lb	kg
Convertible Bench Cabinet	8 1/2	216	3 27/32	98	9 13/16	249.5	5.5	2.2	8	3.7
Rack	19	483	3 15/32	88.5	10 3/16	259	7.0	3.2	10	4.6

TABLE OF CONTENTS

Section 1	INTRODUCTION	1
1.1	Purpose	1
1.2	Description	2
1.3	Controls and Connectors	2
1.4	Accessories Supplied	3
1.5	Accessories Available	3
Section 2	INSTALLATION	5
2.1	Dimensions	5
2.2	Bench Mounting	6
2.3	Relay-Rack Mounting	6
2.4	Connecting the Power	7
Section 3	PROPERTIES OF RANDOM NOISE	9
3.1	Definitions	9
3.2	Description of Random Noise	9
3.3	Amplitude Distribution	10
3.4	Spectrum	11
3.5	Stationarity	12
3.6	Summary	13
Section 4	PRINCIPLES OF OPERATION	15
4.1	Description of Circuit	15
Section 5	OPERATING PROCEDURE	17
5.1	General	17
5.2	Spectrum Control	17
5.3	Output Level Control	18
5.4	Output Connections	18
5.5	Use of Auxiliary Equipment to Modify Output	18
5.6	Generating Two Partially-Correlated Random-Noise Signals	19
Section 6	APPLICATIONS	21
6.1	General	21
6.2	Use of Noise in Electrical Testing	22
6.3	Use of Noise in Acoustical and Psychoacoustical Testing	23
6.4	Vibration Testing	23
6.5	Demonstrating Statistical Properties	23
Section 7	SERVICE AND MAINTENANCE	25
7.1	Warranty	25
7.2	Service	25
7.3	Minimum-Performance Standards	25

(Continued)

TABLE OF CONTENTS (cont)

7.4	Trouble Analysis	26
7.5	Recalibration	26
7.6	Knob Removal	27
7.7	Knob Installation	27
7.8	Pilot-Lamp Removal	27
SCHEMATIC		29
PARTS LIST		30

Section 1—Introduction

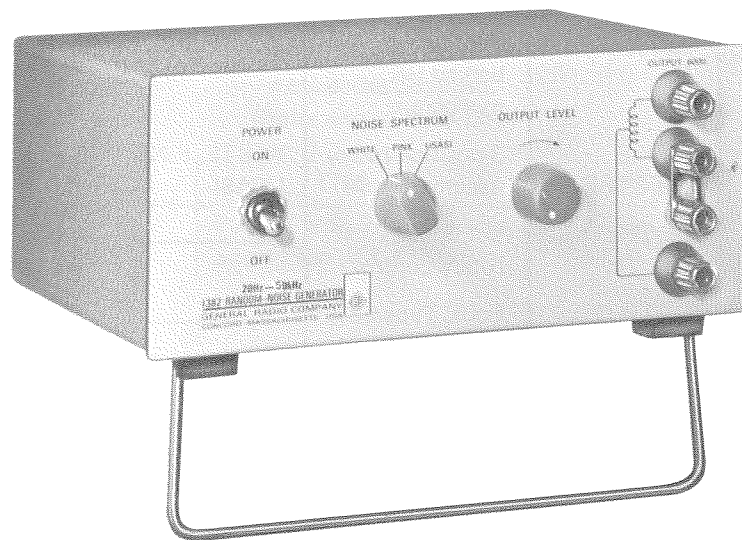

Figure 1-1.

Type 1382 Random-Noise Generator (20 Hz to 50 kHz).

1.1 PURPOSE.

The Type 1382 Random-Noise Generator (Figure 1-1) provides a high level of electrical noise at its output terminals. This type of signal is useful in room-acoustics studies, loudspeaker and microphone tests, psychoacoustic tests, filter tests, crosstalk measurements, calibration checks on recording systems, modulation of signal generators and test oscillators, shaker-driven vibration tests, and airborne vibration tests. It can also be used for tests of the rms response of meters, observation of resonances in systems, electrical averaging of resonant responses, comparisons of effective bandwidths, and for other tests when a signal with a high peak-to-rms factor is

useful, as in overload testing. The choice of spectra and the provision of a balanced output make the Type 1382 Random-Noise Generator particularly suitable for audio and acoustical applications. A pair of these generators can be used as signal sources for the demonstration of various degrees of correlation, possible errors of random sampling, and other concepts of statistical theory.

A companion instrument, the Type 1381 Random-Noise Generator, produces white noise over the range from 2 Hz to upper cutoff frequencies of 2, 5, or 50 kHz. Its output noise can be clipped, if desired, at 2, 3, 4, or 5 σ .

1.2 DESCRIPTION.

The Type 1382 Random-Noise Generator consists of a semiconductor noise source, with all-semiconductor amplifiers and power supply.

Three jack-top binding posts, used as output terminals, are provided on the front panel. A fourth binding post, located between the two lower posts, is connected to the case of the instrument and to the ground wire of the three-wire power cord. A captive shorting link between this post and either of the adjacent posts facilitates grounding one side of the center tap of the output transformer, if desired. The output is also available at three jacks on the rear panel.

1.3 CONTROLS, CONNECTORS AND INDICATORS.

The controls, connectors, and indicators on the Type 1382 Random-Noise Generator are listed in Tables 1-1 and 1-2.

TABLE 1-1
Controls, connectors, and indicators on the front panel.

FIGURE 1-2 REF.	NAME	TYPE	POSITIONS	FUNCTION
1	POWER	2-position toggle switch	OFF, POWER	Energizes instrument.
2	_____	Pilot lamp behind GR monogram	_____	Indicates when instrument is energized.
3	NOISE SPECTRUM	3-position rotary selector switch	WHITE, PINK, USASI	Selects spectrum
4	OUTPUT LEVEL	Continuous rotary control	_____	Varies output voltage
5	OUTPUT 600 Ω	Four, Type 938, in-line, jack-top binding posts spaced 3/4 inch on centers	_____	Removable shorting link connects either the low side of the output transformer or the center tap directly to chassis ground.

TABLE 1-2
Controls and connectors on the rear panel.

FIGURE 1-3 REF.	NAME	TYPE	POSITIONS	FUNCTION
1	OUTPUT	Banana-plug jacks	_____	Three jacks, spaced 3/4 inch on centers, in parallel with OUTPUT terminals on front panel.
2	FUSE 0.1 A	Extraction-post fuse holder	_____	Holds 0.1-A fuse (Slo-Blo).
3	_____	Screwdriver-operated slide switch	100-125 200-250	Selects proper range of line voltage.
4	_____	3-terminal male connector	_____	Line-power input connection.

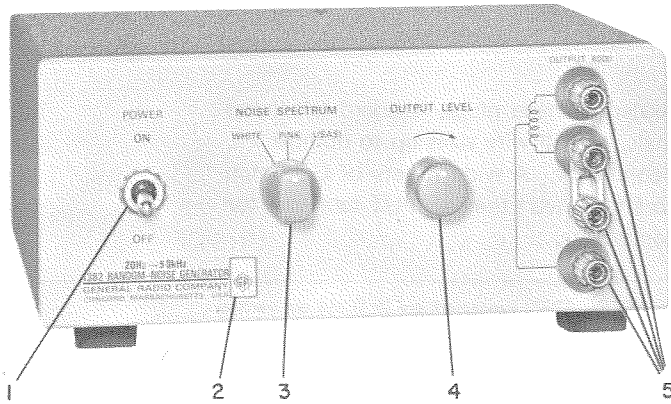

Figure 1-2.

Controls, connectors, and indicators on the front panel of the generator.

1.4 ACCESSORIES SUPPLIED.

The accessories supplied with the Generator are listed in Table 1-3.

1.5 ACCESSORIES AVAILABLE.

A Rack Adaptor Set (P/N 0480-9722) is available to convert the portable bench model for mounting in an EIA standard 19-inch relay rack (refer to paragraph 2.3). Also available are various patch cords (refer to Table 1-4) for making connections to the OUTPUT terminals.

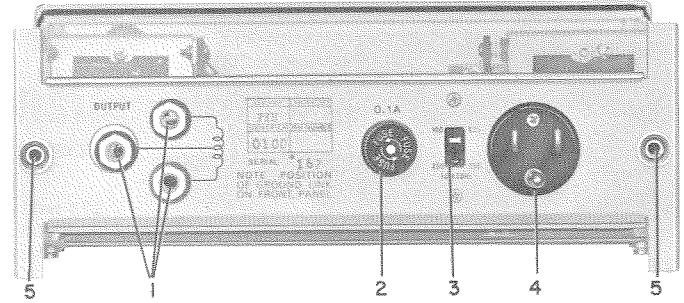

Figure 1-3.

Controls and connectors on the rear panel.

TABLE 1-3
Accessories Supplied.
(Refer also to Parts List.)

	ITEM	GR PART NO.
1	Power Cable, 7-foot, 3-wire	4200-9622
1	Spare Fuse (0.1 A, Slo-Blo)	5330-0400

TABLE 1-4
Available patch cords and adaptors for output connections.

The front-panel OUTPUT binding posts accept banana plugs, standard telephone tips, alligator clips, crocodile clips, spade terminals, and all wire sizes up to number 11. The rear-panel OUTPUT jack is a female BNC connector. A wide variety of GR patch cords is available, as well as a full line of adaptors to convert the OUTPUT terminals for use with most commercial and military coaxial connectors.

NOTE: GR874 connectors are 50 Ω and are mechanically sexless; i.e., any two, although identical, can be plugged together.

TYPE NO.	DESCRIPTION	CATALOG NO.
274-NQ	Double-plug patch cord, in-line cord, 36" long	0274-9860
274-NQM	Double-plug patch cord, in-line cord, 24" long	0274-9896
274-NQS	Double-plug patch cord, in-line cord, 12" long	0274-9861
274-NP	Double-plug patch cord, right-angle cord, 36" long	0274-9880
274-NPM	Double-plug patch cord, right-angle cord, 24" long	0274-9892
274-NPS	Double-plug patch cord, right-angle cord, 12" long	0274-9852
274-NL	Shielded double-plug patch cord, 36" long	0274-9883
274-NLM	Shielded double-plug patch cord, 24" long	0274-9882
274-NLS	Shielded double-plug patch cord, 12" long	0274-9862
274-LLB	Single-plug patch cord, black, 36" long	0274-9468
274-LLR	Single-plug patch cord, red, 36" long	0274-9492
274-LMB	Single-plug patch cord, black, 24" long	0274-9847
274-LMR	Single-plug patch cord, red, 24" long	0274-9848
274-LSB	Single-plug patch cord, black, 12" long	0274-9849
274-LSR	Single-plug patch cord, red, 12" long	0274-9850
1560-P95	Adaptor cable, double-plug to telephone plug, 36" long	1560-9695
874-R34	Coaxial patch cord, double plug to GR874, 36" long	0874-9692
874-R33	Coaxial patch cord, two plugs to GR874, 36" long	0874-9690
274-QBJ	Adaptor, shielded double plug to BNC	0274-9884
776-A	Patch cord, shielded double plug to BNC	0776-9701
776-B	Patch cord, GR874 to BNC	0776-9702
776-C	Patch cord, BNC to BNC	0776-9703

Section 2—Installation

2.1 DIMENSIONS.

The dimensions of the 1382 are shown in Figure 2-1.

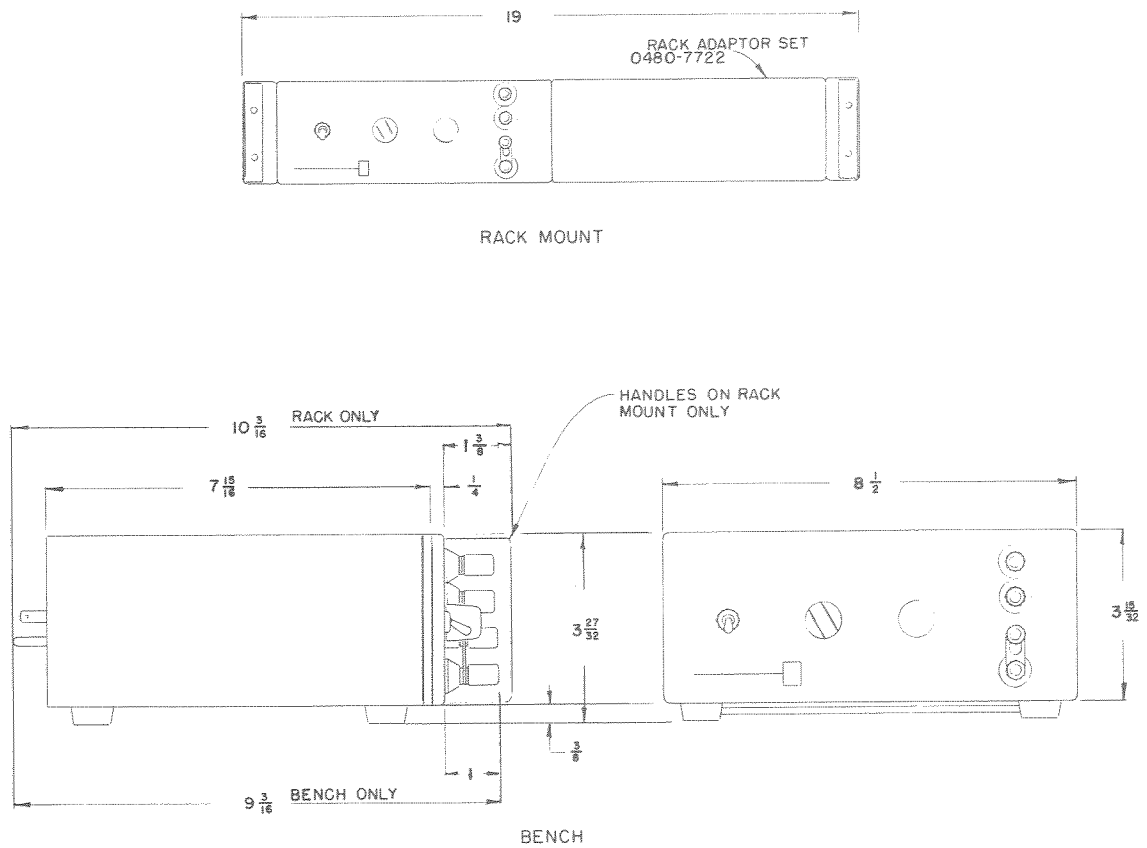

Figure 2-1.
Dimensions of the generator, in inches.

2.2 BENCH MOUNTING.

The 1382 Random-Noise Generator is delivered completely assembled in a metal cabinet, ready for bench use. A convenient bail, located between the front feet, can be pulled down to raise the front of the instrument and provide a better view of the control settings.

2.3 RELAY-RACK MOUNTING.

2.3.1 Single Instrument and Blank Panel (Figure 2-2).

Rack Adaptor Set (P/N 0480-9722) is available to convert the portable bench model for use in an EIA standard 19-inch relay rack. Table 2-1 lists the parts included in the Rack Adaptor Set. The conversion procedure is as follows (see Figure 2-2):

a. Loosen the two captive 10/32 screws (5, Figure 1-2) in the rear of the cabinet until the instrument is free; slide the instrument forward, out of the cabinet.

b. Remove the four rubber feet from the cabinet. Simply push out the two rear feet. Spread the bail (A, Figure 2-2) slightly and the two front feet (B) and the bail will drop out. Be sure to save all parts as they are removed for possible reconversion of the instrument to bench mounting.

c. Pierce and push out the plugs from the four bosses (C) on the inner sides of the cabinet, near the front. Do not damage the threads in the threaded holes.

d. Press the subpanel (D) into the blank panel (E), to form a liner for the latter.

e. Attach the short flange of the blank panel to the front of the cabinet (on either side of the cabinet, as desired) using two 5/16-inch screws (F). Note that the screws enter in opposite directions — one from inside the cabinet and one from the flange side, as shown.

f. Pierce and push out the plug in the lower rear boss (G) on the side toward the blank panel only, as shown.

g. Attach one end of the support bracket (H) to the lower rear boss. The bracket must be placed so that the screw passes through a clearance hole, into a tapped hole. Lock the bracket in position with a 5/16-inch screw (J).

h. Attach the other end of the support bracket to the lower, rear hole in the wide flange, as shown, using a 5/16-inch screw (K).

i. Attach one Rack Adaptor Assembly (handle) to the side of the cabinet opposite the blank panel, using two 5/16-inch screws (L). Again, note that the screws enter in opposite directions, one from inside the cabinet and one from outside. Use the upper and lower holes in the Assembly.

j. Attach the other Rack Adaptor Assembly (handle) to the wide flange on liner (D) and the flange on the blank panel (E). Use two 5/16-inch screws (M) through the two holes in the flange that are nearest the panel and through the upper and lower holes in the Assembly. Again, the screws enter in opposite directions.

k. Install the instrument in the cabinet and lock it in place with the two captive screws through the rear panel that were loosened in step a.

l. Place a straight edge across both the instrument panel and the blank panel. Loosen the screw (J) through the slot in the support bracket (H). Exert a slight pressure on the blank panel (E) so that it forms a straight line with the instrument panel, and tighten the screw (J) in the bracket, to lock the panels in this position.

m. Slide the entire assembly into the relay rack and lock it in place with the four 9/16-inch screws (N) with captive nylon cup washers. Use two screws on each side and tighten them by inserting a screwdriver through the holes (P) in the handles.

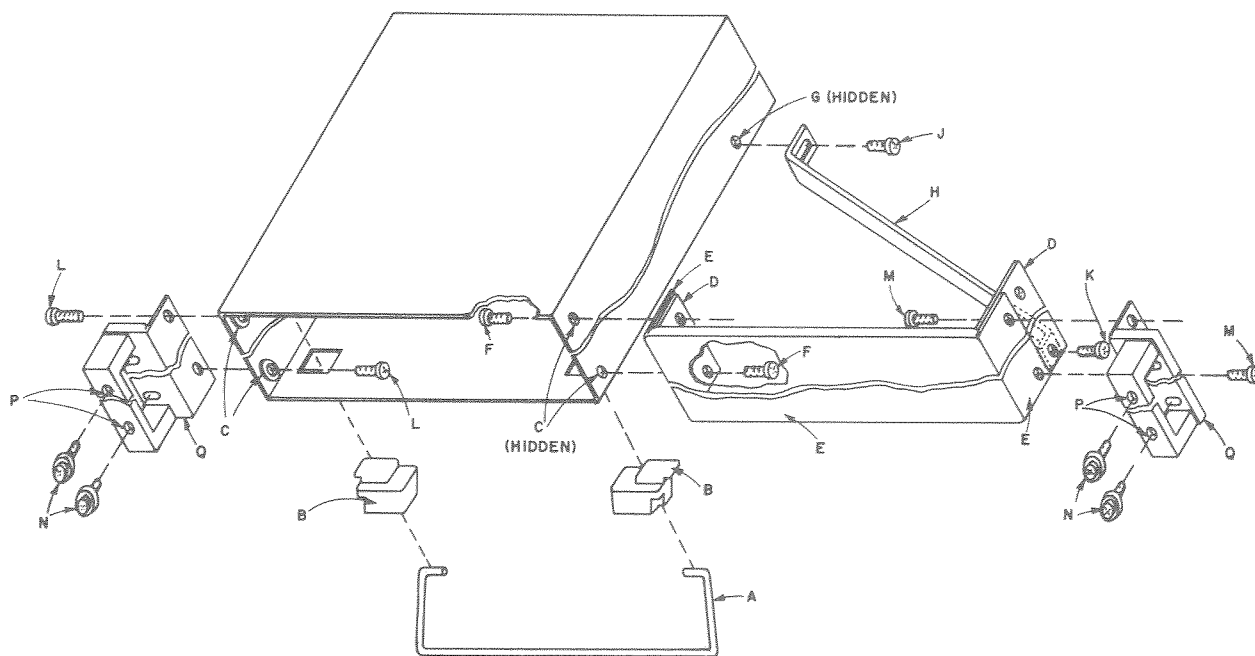

Figure 2-2.

Method of mounting the generator and a blank panel in a relay rack.

2.3.2 Reconverting to Portable Bench Mounting.

To reconvert the instrument for bench use, reverse the procedures of paragraph 2.3.1, first removing the entire assembly of instrument, cabinet, and blank panel from the rack. Next remove:

- a. The instrument from its cabinet.
- b. The support bracket (H) from the cabinet (see Figure 2-2).
- c. The blank panel (E) (with handle attached) from one side of the cabinet.
- d. The Rack Adaptor Set (handle) from the other side of the cabinet.

Push the two rear feet into the cabinet; slide the bail (A) and two front feet (B) into place. Install the instrument in its cabinet and lock it in place with the two captive screws through the rear panel (see Figure 1-3).

2.3.3 Rack-mounting Two Instruments.

Two instruments of the same panel size (such as two 1382's or one 1381 and one 1382) can be mounted side-by-

side in a standard 19-inch relay rack. Use the procedure of paragraph 2.3.1, substituting the second instrument for the blank panel. Do not use the support bracket (H, Figure 2-2), but insert three screws through the bosses in the adjacent sides of the cabinets, two near the front (C) and one near the rear (G). The four feet and the bail must, of course, be removed from each cabinet. Use the four screws (N) with nylon washers to lock the instruments in the rack. The required hardware is listed below:

3 Screws, BH 10-32 5/16 P/N7080-0800

4 Screws, BH 10-32, 9/16 with nylon washers P/N7207-6310

2.4 CONNECTING THE POWER.

The wiring of the power transformer can be switched, by means of the 2-position slide switch (3, Figure 1-2) on the rear panel, to accept 50- to 400-Hz line power of either 100-125 volts or 200-250 volts.

Connect the 3-wire power cable (P/N 4200-9622) supplied to the line and to the 3-terminal male connector (4, Figure 1-2) on the rear panel. A single 0.1-A fuse is used for either line voltage. Power consumption is approximately 6 W.

TABLE 2-1
PARTS INCLUDED IN THE RACK ADAPTOR SET,
P/N 0480-9722 (see Figure 2-2).

Fig. 2-2 Ref.	No. Used	Item	GR Part No.
E	1	Blank Panel	0480-8932
D	1	Sub-Panel	0480-8952
—	2	Rack Adaptor Assembly	0480-4902
H	1	Support Bracket	0480-8524
—	1	Hardware Set	0480-3080
		includes	
F, J, K, L, M,		8 Screws, BH 10-32, 5/16"	7080-0800
N		4 Screws, BH 10-32, 9/16" w. nylon cup washers	7270-6310

Section 3— Properties of Random Noise

3.1 DEFINITIONS.

The acoustical term "noise" was applied originally to certain electrical signals because of the undesirable audible effects they produced at the output of radio receivers. Noise, in the electrical sense, is now a broad term that means any unwanted signal, and therefore can include not only input-stage noise and atmospheric noise in radio receivers, but also crosstalk, hum, and distortion.

Random noise is a signal whose exact value at any future moment cannot be predicted. It is even a little more than that; it means a signal containing no periodic component whose future value can be predicted. Unlike periodic signals,

whose spectra consist of one or more discrete lines corresponding to the various frequency components, random noise has a spectrum that is a continuous function of frequency, containing no discrete line components.

3.2 DESCRIPTION OF RANDOM NOISE.

It is only possible to describe random noise in terms of its average properties that cannot be measured instantaneously but must be averaged over some finite measurement time. The two most important characteristics of random noise are its amplitude distribution and its spectrum.

3.3 AMPLITUDE DISTRIBUTION.

3.3.1 Amplitude Distribution Functions.

The instantaneous value of a random noise, at some particular instant, cannot be predicted, but for many noises we can speak of the probability that the voltage will lie in some particular range. This probability is given by a function called the amplitude density distribution, $p(v)$. When multiplied by a voltage increment, dv , this function gives the probability that, at any given instant, the voltage lies between v and $v + dv$. Because the voltage must exist at some value, it follows that the integral

$$\int_{-\infty}^{\infty} p(v)dv = 1.$$

Another useful probability function is the integral over part of that range, called the amplitude distribution, $P(v)$, defined as

$$P(v) = \int_{-\infty}^v p(x)dx.$$

Thus defined, $P(v)$ is the probability that the voltage, at any given instant, lies below the value v . The values of these probability functions lie on a scale between 0 and 1, with 1 denoting certainty. A probability of 0.5 denotes a 50% chance of occurrence.

3.3.2 The Gaussian Distribution.

The Gaussian or normal distribution is particularly important for several reasons: It describes the "normal" occurrence of random measurement errors in experiments. The amplitude of thermal noise in a resistance and shot noise in a vacuum tube are Gaussianly distributed. The distribution of the sum of many independent time-varying voltages approaches the Gaussian distribution in the limit as the number of such voltages is increased, regardless of the distribution of the individual voltages (derived from the Central Limit Theorem of statistics). An extension of this reasoning leads to the result that filtering that reduces the bandwidth generally makes a non-Gaussian noise more Gaussian, so that, in this sense, the Gaussian is a stable distribution. For these reasons, the Gaussian distribution is of fundamental importance and is the most appropriate distribution of random noise in most experiments. For the Gaussian distribution,

$$p(v) = \left(\frac{1}{\sigma\sqrt{2\pi}} \right) e^{-\frac{v^2}{2\sigma^2}}$$

and

$$P(v) = \frac{1}{2} \left[1 + \operatorname{erf} \left(\frac{v}{\sigma\sqrt{2}} \right) \right]$$

where σ is the root-mean-square voltage (in statistics, the

standard deviation), and erf denotes the error function. Values of these functions are given in Table 3.1 and the functions are graphed in Figures 3.1 and 3.2.

TABLE 3-1
Gaussian amplitude distribution functions.

v	$p(v)$	$P(v)$
-5σ	.000 001 487/ σ	.000 000 287
-4σ	.000 133 8/ σ	.000 031 67
-3σ	.004 432/ σ	.001 350
-2σ	.053 99/ σ	.022 75
-1σ	.241 97/ σ	.158 65
0	.398 94/ σ	.500 00
1σ	.241 97/ σ	.841 34
2σ	.053 99/ σ	.977 25
3σ	.004 432/ σ	.998 650
4σ	.000 133 8/ σ	.999 968 33
5σ	.000 001 487/ σ	.999 999 713

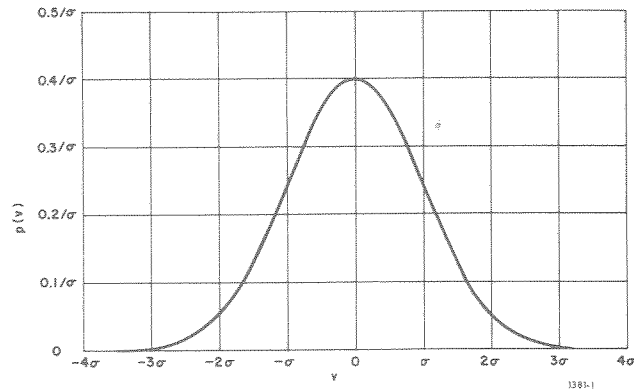

Figure 3-1.
The Gaussian probability density function plotted as a function of σ , the root-mean-square amplitude.

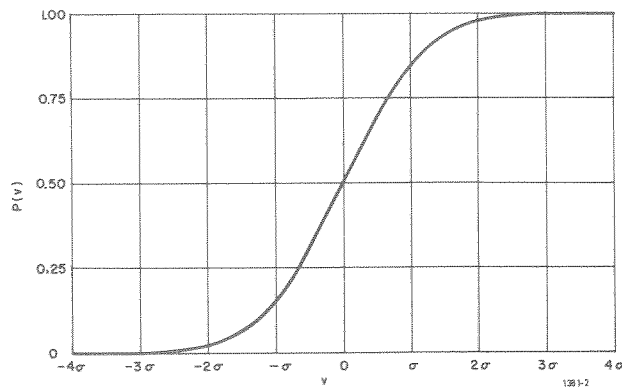

Figure 3-2.
The Gaussian probability distribution function plotted as a function of σ , the root-mean-square amplitude.

It can be seen from Figure 3.2 that a Gaussianly distributed random noise lies below its positive root-mean-square value ($\sigma = 1$) 84% of the time, and therefore exceeds that value only 16% of the time.

3.3.3 Importance of Knowing the Distribution.

Knowledge of the amplitude distribution of a noise is important in measuring its magnitude. Electronic voltmeters respond to different measures of the amplitude of the voltage, such as the rms, the peak, or the (full-wave-rectified) average. The peak and average values of various waveforms having 1-volt, rms, amplitude are given in Table 3-2. A voltmeter responding to the average and calibrated to indicate the rms value of a sine wave will, when measuring Gaussian noise, indicate a value that is low by the factor $0.798/0.900 = 0.887$ (-1.05 dB)¹. Voltmeters that respond to the true rms value are quite appropriate for the measurement of noise, because they can indicate the rms value without correction, regardless of the amplitude distribution. The response of a peak-indicating voltmeter is dependent upon the charging and discharging time constants of its rectifier circuits; when random noise is measured, each may indicate a different value. The response time of a rectified-average-responding voltmeter is usually shorter than that of the true rms voltmeter. Therefore, for measuring the amplitude of Gaussianly-distributed noise, the average-responding voltmeter is probably the most convenient (using the necessary correction factor). In order to measure the rms of non-Gaussian noise, or to make the measurement with no correction factor, it is necessary to use a true-rms instrument.

TABLE 3-2
Rms, peak, and full-wave rectified average voltage values
of various waveforms.

	RMS	PEAK	FULL-WAVE RECTIFIED AVERAGE
Sine Wave	1.0	$1.414 (\sqrt{2})$	$0.900 \left(\frac{2\sqrt{2}}{\pi} \right)$
Square Wave	1.0	1.0	1.0
Gaussian Noise	1.0	∞	$0.798 \left(\sqrt{\frac{2}{\pi}} \right)$

3.3.4 Measuring Amplitude Distribution.

The amplitude distribution, $P(v)$, can be measured by means of a circuit that measures the percentage of time during which the noise voltage exceeds (or does not exceed) the voltage level, v . Apparatus for this purpose generally includes some form of level-crossing detector, and, for high-speed operation, Schmitt-circuit wave-shapers. The measurement must be made by averaging over a time long enough to smooth the fluctuations in the indication to negligible size.

The amplitude density distribution, $p(v)$, can be measured by similar, but somewhat more complicated, apparatus that indicates the percentage of time that the noise voltage exists within the range from v to $(v + dv)$. In making any of

¹This and much other information concerning random noise is contained in a General Radio publication, "Useful Formulas, Tables and Curves for Random Noise", Instrument Note IN-102 (June, 1963). A copy of this six-page compendium can be obtained free of charge by writing to General Radio, West Concord, Mass. 01781.

these measurements, averaging is important, because only the average characteristics of the noise can be measured meaningfully.

3.3.5 Amplitude Distribution of the Type 1382 Random-Noise Generator.

Care has been taken to ensure that the amplitude distribution of the noise generated by the Type 1382 Random-Noise Generator is truly Gaussian. The output amplifier has been designed so that clipping cannot occur below 4σ at full output, and below even higher values of σ as the output is reduced. Special attention has been given to the symmetry of the distribution. Checks for the occurrence of peaks to 4σ and 5σ have been made, and the occurrence of such amplitudes has been found to be as predicted within experimental error.

3.4 SPECTRUM.

3.4.1 General.

The spectrum of a random signal is different from that of a periodic signal, which is composed of one or more discrete lines, each of which corresponds to a frequency component of the periodic signal. A truly random signal contains no periodic frequency components, and has a spectrum that is a continuous function of frequency.

3.4.2 Spectrum Functions.

The frequency content of a random noise is described by a function called the spectral intensity, which has the dimensions of voltage squared per unit bandwidth. (When divided by a value of resistance, it is equal to the power that voltage would dissipate in that resistance, per unit bandwidth). The spectral intensity is the Fourier transform of the autocorrelation function, and is the spectrum function most often used in mathematical analysis of random noise. It is not the most convenient function for practical use, however, because spectra are usually measured as voltage, rather than voltage squared, in a given bandwidth, and filter responses, used in shaping noise spectra, are usually measured as voltage functions. Therefore, for practical use, we define the voltage spectrum as numerically equal to the square root of the spectral intensity. It has units of voltage per square root of bandwidth, but may be spoken of as voltage in a given bandwidth. Spectra shown in Figure 3-3 are plotted as voltage spectra.

3.4.3 White Noise.

Noise whose spectral intensity is constant over a range of frequencies is called white noise, by analogy with white light, which contains more or less equal intensities of all visible colors.² White noise cannot contain equal amplitudes at all

²Although, as Bennett (op. cit., p. 14) points out, the analogy has been drawn incorrectly, because spectroscopists were measuring intensity as a function of wavelength, and found it to be substantially constant per unit wavelength, not per unit frequency.

frequencies, for then the total power in the noise would be infinite. White noise, therefore, means that the spectrum is flat over the range of interest, for example, throughout the audio-frequency range. Because of its flat spectrum, white noise is particularly convenient as a starting point for many experiments.

3.4.4 Importance of Knowing the Spectrum.

In most experiments involving random noise, knowledge of the spectrum of the noise being used is vitally necessary. When noise is used as a driving-point signal to determine the response of some system, the response is meaningful only when the input spectrum is known, and is usually most conveniently studied when the input spectrum is flat. There are, of course, cases where other spectra are more convenient. If, in such cases, a filter can be constructed whose response has the shape of the desired spectrum, white noise is the proper input for that filter to produce the desired spectrum at its output.

3.4.5 Noise-Spectra Measurements.

The spectrum of a noise can be measured with any wave analyzer whose frequency range is appropriate. For the output indication to be free of fluctuations that might cause reading errors, the product of analysis bandwidth and the averaging time must be large. As in the measurement of the amplitude distribution, the spectrum can only be measured accurately by averaging over a relatively long time interval.

Wave analyzers generally indicate the voltage in the analysis passband. The indication is therefore proportional to $w(f)$, not $W(f)$. It is convenient to reduce all measurements to a common bandwidth basis, and the most-often-used bandwidth is one cycle. Units for $W(f)$ are "volts squared per cycle bandwidth," and considerable use has been made of the unit "volts per root-cycle" for $w(f)$. Now that "cycles" have become "hertz," this term is even more cumbersome, and is perhaps best replaced by "volts in a 1-hertz band."

In order to convert to volts in a 1-hertz band, it is necessary to divide the voltage indication of the analyzer by the square root of the analysis bandwidth. For example, using the General Radio Type 1900 Wave Analyzer, multiply by the factors given in Table 3-3 to convert measured values of random noise to volts in a 1-hertz band.

TABLE 3-3
Correction factors for converting voltage indication of the Type 1900 Wave Analyzer to voltage in a 1-hertz band.

ANALYZER BANDWIDTH	CORRECTION FACTOR ¹
3 Hz	0.650 (-3.7 dB)
10 Hz	0.357 (-9.0 dB)
50 Hz	0.159 (-15.9 dB)

¹These numbers include the correction for the average-responding voltmeter in the 1900 Wave Analyzer.

In a constant-percentage-bandwidth analyzer, the analysis bandwidth is directly proportional to the center frequency of the pass band. This necessitates dividing the voltage indication by the square root of the frequency as well as by the correction factor for the fractional bandwidth itself. When using constant-percentage-bandwidth analyzers, such as the General Radio Type 1564 Sound and Vibration Analyzer or the Type

1558 Octave-Band Analyzer, multiply the analyzer voltage indication by the appropriate conversion factor in Table 3-4.

TABLE 3-4
Correction factors for converting voltage indication of a constant-percentage-bandwidth analyzer to voltage in a 1-hertz band.

BANDWIDTH	CORRECTION FACTOR
1/10 Octave	$3.80/\sqrt{f}$
1/3 Octave	$2.08/\sqrt{f}$
1 Octave	$1.19/\sqrt{f}$

3.4.6 Spectra of Type 1382 Random-Noise Generator.

The noise output of the Type 1382 Random-Noise Generator is adjustable to either of three different spectral shapes. The spectrum level of the WHITE noise is substantially constant from 20 Hz to 20 kHz, and is 3 dB down at 50 kHz. The spectrum level of PINK noise slopes downward at 3 dB per octave, from 20 Hz to 20 kHz. The spectrum of USASI noise, as specified in USASI (formerly ASA) Standard S1.4, "American Standard Specification for General Purpose Sound-Level Meters" (1961), reflects the combined effect of two RC networks acting independently on white noise. One is a high-pass network with corner frequency at 100 Hz and a cutoff slope of 6 dB per octave; the other is a low-pass network with a corner frequency of 320 Hz and the same cutoff slope. These three spectra are shown in Figure 3-3. The output voltage is the same for any position of the NOISE SPECTRUM control, so the spectral levels at certain frequencies vary widely from one spectrum to another. The relative spectral levels are as indicated in Figure 3-3.

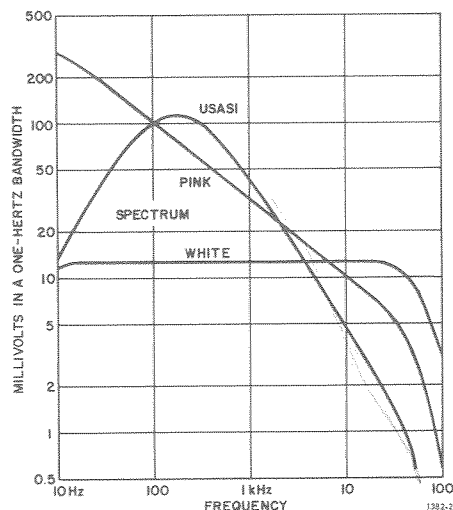

Figure 3-3.
Voltage spectra of the 1382 for the three different output spectra at 3 volts, rms, output level.

3.5 STATIONARITY.

A random noise is said to be stationary³ if its various statistical parameters such as the amplitude distribution and the spectral intensity do not change with time. Random noise,

³Bennett, op. cit., p. 52-54.

of course, never repeats the same pattern from one moment to the next, but, if it is stationary, many measurements of the spectrum made at different times will all indicate the same result, except for the unavoidable errors of measuring a random quantity in a finite time. In discussing tests for stationarity, Bendat and Piersol⁴ point out that, for most noise-generating processes, it is sufficient to determine that the mean and the variance (square of the standard deviation, σ) do not change with the time at which they are measured. Because the output of the 1381 is ac coupled, the mean is automatically zero, and it is only necessary to observe the rms amplitude to prove stationarity. This can be done by seeing that the fluctuations in long-time recordings of the amplitude of the noise are no greater than the value predicted from the bandwidth of the noise and the smoothing time of the detector.

Tests of this type have been applied to the 1382 and no departure from stationarity is detectable. The importance of stationarity in a random noise generator is analogous to stability of an oscillator; the user is assured that there is no change in

the spectrum or the amplitude distribution during the course of the experiment.

3.6 SUMMARY.

Because various terms used in speaking of random noise are sometimes confused, a summary is presented here of the most-often-used words, together with a brief explanation of their meaning: "Noise" is any unwanted signal. "Random noise" is a signal whose future value cannot be exactly predicted and that does not contain any periodic components. To differentiate clearly between the spectrum and the amplitude distribution, in this book the word "density" is used only in connection with the amplitude distribution. The word "intensity" is used only in connection with the spectrum. "Gaussian" applies only to the amplitude distribution and refers to a particular theoretical distribution. "White" refers only to the spectrum, and means that the spectral intensity is constant over some range of interest.

BIBLIOGRAPHY

1. Bennett, W. R., *Electrical Noise*, McGraw-Hill Book Co., Inc., New York (1960).
2. Peterson, A. P. G., "Response of Peak Voltmeters to Random Noise," *General Radio Experimenter*, 31, No. 7, December, 1956, p 3-8.
3. Hilibrand, J., "Characterization of Probability Distributions for Excess Physical Noises," Research Laboratory of Electronics, Massachusetts Institute of Technology, Cambridge, Mass., *Technical Report 276*, September 7, 1956.
4. Bendat, J. S. and Piersol, A. G., *Measurement and Analysis of Random Data*, John Wiley & Sons, Inc., New York, 1966, pp 219-223.
5. American Standards Association (now United States of America Standards Institute), *American Standard Specification for General-Purpose Sound Level Meters, Standard S1.4, 1961*, New York.
6. MIL-STD-188B, U. S. Army Electronics Command, Fort Monmouth, New Jersey.
7. Beranek, L. L., *Acoustic Measurements*, John Wiley & Sons, Inc., New York, 1949.
8. Holtje, M. C., and M. J. Fitzmorris, "A Graphic Level Recorder with High Sensitivity and Wide Ranges," *General Radio Experimenter*, Vol 33, No. 6, June, 1959.
9. A useful bibliography for these applications is: S. S. Stevens, J. G. S. Loring, and Dorothy Cohen, *Bibliography on Hearing*, Harvard University Press, Cambridge, 1955, particularly those references listed in Sections 139 (p 571), 157 (p 573), and 222-228 (pp 579 f).
10. Faran, J. J., Jr., and R. Hills, Jr., *The Application of Correlation Techniques to Acoustics Receiving Systems*, Acoustics Research Laboratory, Harvard University, Cambridge, Mass., Technical Memorandum No. 28, November, 1952.
11. Crandall, S. H., editor, *Random Vibration, Volume 2*, The M.I.T. Press, Massachusetts Institute of Technology, Cambridge, Mass., 1963.
12. General Radio Co., "Distribution of Random Noise Voltages," *Experiments for the Student Laboratory*, No. STX-104, January, 1967. (Copies of this publication may be obtained free of charge from the General Radio Co., W. Concord, Mass., 01781.)
13. General Radio Co., "Useful Formulas, Tables, and Curves for Random Noise," *Instrument Notes*, No. IN-103, June, 1963. (Copies of this publication may be obtained free of charge from the General Radio Co., W. Concord, Mass., 01781.)
14. Kundert, W. R., "New Performance, New Convenience, with the New Sound and Vibration Analyzer," *General Radio Experimenter*, Vol 37, No. 9 & 10, September-October, 1963.
15. Arthur A. Rieger and Harvey H. Hubbard "Response of Structures to High Intensity Noise," *Noise Control*, Vol 5, No. 5, September, 1959, pp 13-19.

⁴Bendat and Piersol, op. cit., p. 219-222.

Section 4—Principles of Operation

4.1 DESCRIPTION OF CIRCUIT.

Figure 4-1 is a block diagram of the Type 1382 Random-Noise Generator (refer also to Figure 7-3). The noise source is a semiconductor diode (CR101). The noise is amplified in a band-pass amplifier with an automatic-gain-control circuit that maintains a constant output level (Q101 through Q106 plus CR102 and CR103). The passband of this amplifier is 100 to 200 kHz. This noise is heterodyned down to the frequency range of 0 to 50 kHz by a balanced modulator (Q107 through Q110). The oscillator that drives the modulator (Q111 and Q112) produces a symmetrical, almost-square wave at 150 kHz. The output of the modulator is passed through a trap circuit to remove remnants of the oscillator signal, through an amplifier (Q113), and then to a low-pass filter whose cutoff frequency is 50 kHz. The noise is then applied to one of three networks that produce the WHITE, PINK, or USASI spectra. The noise is then amplified (Q115 and Q116), applied to the OUTPUT LEVEL control (R149) and again amplified by the output amplifier (Q117 and Q118).

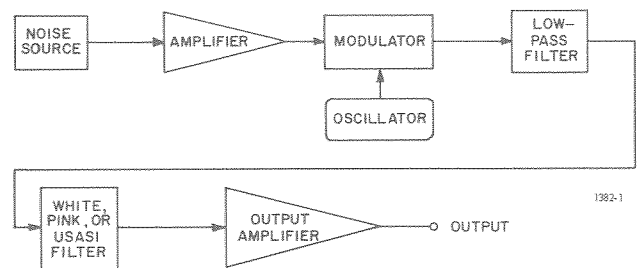

Figure 4-1.
Block diagram of the 1382 Random-Noise Generator.

A voltage-regulated power supply (Q501, Q502, Q503) is used to ensure stability of operation over the specified range of line voltage. A slide switch at the rear of the instrument permits easy changeover of the primary connections of the power transformer for operation on either a 100- to 125-volt or a 200- to 250-volt power line.

Section 5 – Operating Procedure

5.1 GENERAL.

With the instrument placed in position on the bench or installed in a relay rack, set the screwdriver-operated line-voltage slide switch (see Figure 1-3) to the range corresponding to the power-line voltage. Connect the instrument to the line power, using the power cable supplied (P/N 4200-9622), and turn on the POWER switch.

Follow the instructions given in paragraphs 5.2 and 5.3 for setting the SPECTRUM and OUTPUT LEVEL controls.

5.2 SPECTRUM CONTROL.

The SPECTRUM control is a three-position rotary switch that selects the spectrum of the output noise. The three spectra, WHITE, PINK, or USASI, are illustrated in Figure 3-3. Simply turn the switch to the desired spectrum.

5.3 OUTPUT LEVEL CONTROL.

The OUTPUT LEVEL control is a continuous rotary control by means of which the output level can be set at any selected value between its maximum open-circuit value of approximately 3 V and 3 mV (or less). When setting the output level to some specific value, use an average-responding ac voltmeter for the measurement.

5.4 OUTPUT CONNECTIONS.

5.4.1 Output Impedance.

The output impedance of the Type 1382 Random-Noise Generator is 600 Ω . The maximum open-circuit output voltage is 3 V, rms, and occasional peaks of the noise voltage may exceed 4 times that value. The output can be short-circuited without causing distortion of the noise. The maximum output current into a short-circuited load is 5 mA, rms, with occasional peaks that may exceed 4 times that value.

5.4.2 Grounding.

A captive link on the next-to-lowest binding post on the front panel can be secured to either of the binding posts just above or below it. When this is done, either the center tap or the low side of the output-transformer winding is connected to the case of the instrument and, by the third wire in the power cord, to the power-line ground. If the link is not connected, the output winding can be operated above ground ("floating").

5.4.3 Rear-Panel Output Connectors.

Occasionally, it may be desirable to connect to the output of the generator at the rear of the instrument, e.g., when the generator is mounted in a relay rack. Three jacks (2, Figure 1-3), which accept standard banana plugs and are spaced $\frac{3}{4}$ inch on centers, are provided on the rear panel. They are connected in parallel with the three OUTPUT binding posts on the front panel, one to the center tap, one to the low side, and one to the high side of the output transformer (as shown on both panels).

5.5 USE OF AUXILIARY EQUIPMENT TO MODIFY OUTPUT.

5.5.1 Generating Lower Levels.

Various attenuating devices can be connected to the OUTPUT of the generator to reduce the power level. General

Radio Type 1450 Decade Attenuators, with input and output impedances of 600 ohms, can be inserted between the 1382 and a 600-ohm load, for accurate attenuation in decibel steps.

5.5.2 Generating Higher Levels.

The noise generated by the Type 1382 Random-Noise Generator can be amplified by any amplifier whose frequency range is adequate. The high crest factor of Gaussianly distributed random noise must be kept in mind in choosing the power rating of the amplifier, so that the noise is not clipped. An amplifier capable of driving 40 W, sine wave, into a load will be capable of driving only 5 W of random noise into that load if peaks below 4σ are to be passed without clipping.

5.5.3 Generating Bands of Noise.

In some applications it is desirable to use more or less narrow bands of noise. Because the output impedance is 600 Ω , it is a simple matter to drive a filter designed for operation at that impedance level.

Wave analyzers that make the filtered signal available as an output are convenient for use as a filter. For narrow bands of noise of fixed bandwidth, the General Radio Type 1900-A Wave Analyzer can be used. Its bandwidths are 3, 10, and 50 Hz, and its frequency range is 0 to 50 kHz. For constant-percentage bandwidths, several analyzers are available, and their bandwidths are given in Table 5-1.

TABLE 5-1
Analyzers with constant-percentage bandwidths.

ANALYZER	BANDWIDTH
1558	1 octave
1564	1/3, 1/10 octave
1568	1%

The power available at the OUTPUT terminals of these various analyzers is not great; for general utility, the narrow-band noise from the analyzer will need amplification (refer to paragraph 5.5.2).

When the frequency response is measured with bands of noise, several of these analyzers can be synchronized to the chart paper on the 1521 Graphic-Level Recorder, the abscissae of the chart paper indicating the center frequency of the band of noise.

Wider bands of noise can be generated by use of the Type 1952 Universal Filter, which contains independently adjustable low- and high-pass units. Upper and lower cutoff frequencies can be adjusted over the range from 4 Hz to 60 kHz.

5.6 PARTIALLY CORRELATED RANDOM NOISE.

In experiments on correlation techniques, it is sometimes necessary to generate two random-noise signals having a known degree of correlation. Such a pair of signals can be easily produced from two 1381 Random-Noise Generators by connecting a resistor between their high OUTPUT terminals as shown in Figure 5-1. If the output amplitudes are made equal, the normalized correlation coefficient of the two noise signals will be

$$\rho = \frac{\overline{e_1 e_2}}{\sqrt{\overline{e_1^2} \overline{e_2^2}}} = \frac{2R' + 2}{(R')^2 + 2R' + 2}$$

where e_1 and e_2 are the two output voltages, the overbar indicates the time average, R' is $\frac{R}{600}$ and R is the value of resist-

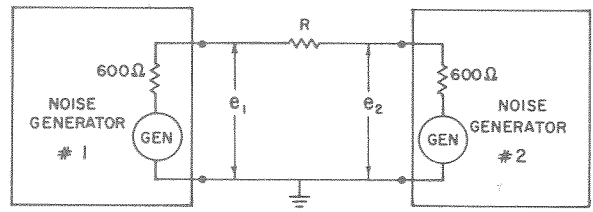

1381-6

Figure 5-1.
Method of producing varying degrees of correlation between the two noise voltages e_1 and e_2 (see Figure 5-2).

tance used. The magnitude of the output voltage is somewhat reduced by the loading on each terminal, and the ratio, r , of the actual output voltage to the open-circuit output voltage is plotted, together with ρ , in Figure 5-2, as a function of R .

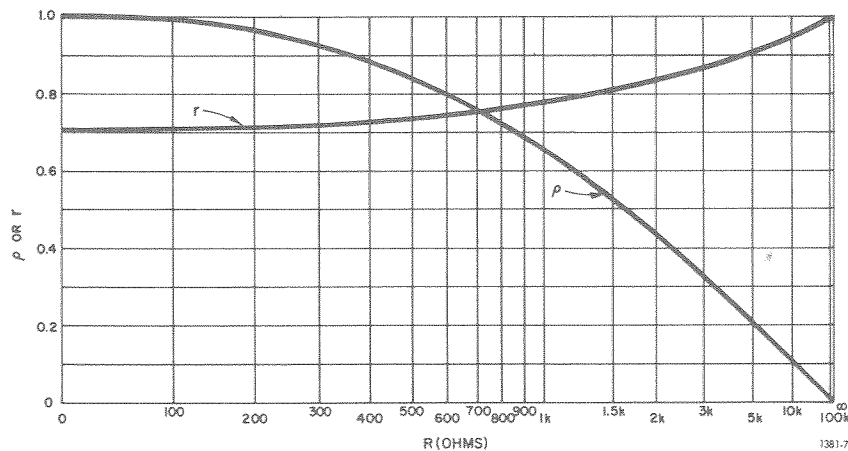

1381-7

Figure 5-2.
Normalized correlation coefficient (ρ) of outputs of two noise generators and ratio (r) of output voltage to that with no resistor, as a function of the resistance connected between the high output terminals of the generators (see Figure 5-1).

Section 6 – Applications

6.1 GENERAL.

The Type 1382 Random-Noise Generator is useful wherever an audio-frequency noise source having white, pink, and USASI spectra and balanced or unbalanced, floating or grounded output is needed. Its companion, the Type 1381 Random-Noise Generator, is useful where its features (variable bandwidth, adjustable clipping, and spectral level constant to very low frequencies) are desirable. In many applications, either of these instruments will serve well, but there are cases where one or the other is particularly appropriate.

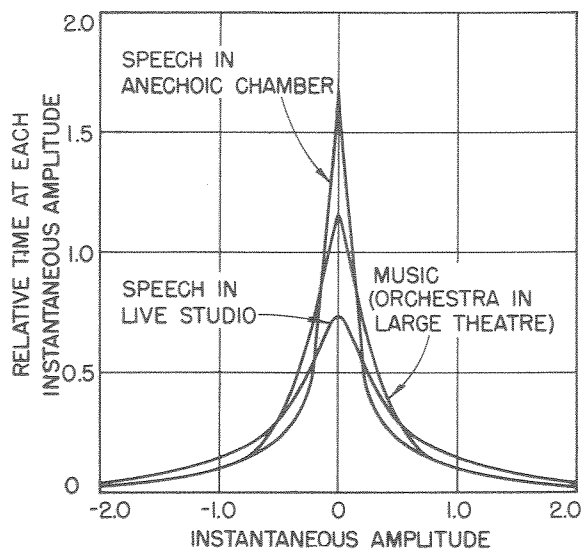

Figure 6-1.

Amplitude distribution curves for various sounds. (Curves labeled "Speech" are for particular cases of sounds produced from readings of printed matter; curve labeled "Music" is an analysis of an orchestral selection made in a large theater.)

Some applications of a noise generator depend on its amplitude-distribution characteristics. For example, the amplitude distribution is similar to that of speech, music, and many other sounds or electrical disturbances that occur natu-

rally,¹ while the amplitude distribution of a sine wave is entirely different. These similarities and differences can be seen by a comparison of the distributions of Figures 6-1 and 6-2.

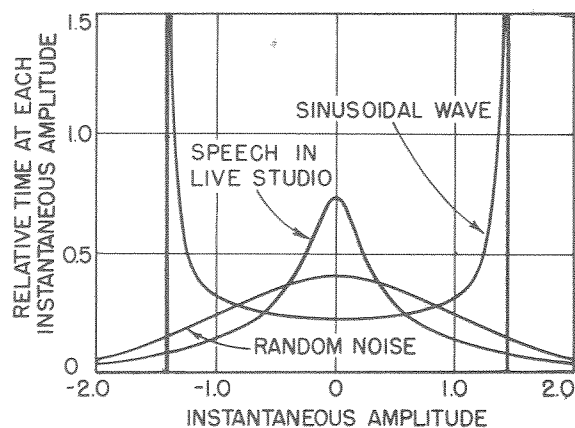

Figure 6-2.

Distribution curves of a single sinusoidal wave and a random noise.

Other applications depend on the various possible frequency spectra of noise. The spectrum is independent of the amplitude distribution, in the sense that a normal (or Gaussian) distribution of amplitudes is possible with any frequency spectrum — flat, broad, narrow, sloping, or peaked. Systems that affect one characteristic, however, may also affect the other. For example, clipping affects both the amplitude distribution and the spectrum. Linear filter networks used on purely random Gaussian noise do not affect the amplitude distribution but do alter the frequency characteristic and, correspondingly, the time scale. Linear filter networks, used after clipped noise, alter the spectrum and, if they reduce the bandwidth significantly, also tend to make the distribution more nearly Gaussian.

¹Dunn, H.K., and White, S.D., "Statistical Measurements on Conversational Speech", *Journal of the Acoustical Society of America*, Vol. 11, No. 3, January 1940, pp 278-288.

6.2 USE OF NOISE IN ELECTRICAL TESTING.

6.2.1 Simulation of Background Noise.

In studying the performance of radio, telemetry, radar or sonar systems with regard to their ability to transmit, detect, and recover signals in noise, it is convenient to simulate the real mixture of signal and naturally occurring noise by adding noise of controlled characteristics to a standard signal. Noise sometimes becomes the signal itself in tests of correlation receivers and other modern signal-processing systems.

6.2.2 Measuring Intermodulation Distortion.

Random noise is used in one very effective method of measuring intermodulation distortion.² White noise, which has been passed through a band-stop filter that reduces the level of the noise by, say, 80 dB over a narrow range of frequencies, is applied to the input of a system. Spectrum measurements of the system output indicate how much the "notch" in the noise spectrum has been filled in by intermodulation products. This is an especially significant measurement because white noise contains all the frequencies to which the system responds, and represents, in this sense, a "worst-case" type of test signal.

6.2.3 Measuring Crosstalk.

White noise is a very appropriate signal for use in measuring crosstalk in multichannel telephone, radio, or telemetry systems. Spectrum analysis of the crosstalk signal identifies the frequencies that cause the greatest disturbance, thereby providing some assistance in determining the cause and specifying a cure.

6.2.4 Testing Response of Meter Circuits.

One of the most straightforward methods of showing that an ac voltmeter circuit responds accurately to the peak, the rms, or the average value of the input voltage is to apply signals to it that have different ratios of peak, rms, and average values, and observe the indications. In addition to sine waves, and short rectangular pulses, Gaussian noise is useful for this purpose.³ Rms, peak, and average values of various waveforms are given in Table 3-2. Although the peak value of Gaussian noise, theoretically, is infinite, the probability of ever observing an extremely large value is very slight. The response of peak-responding voltmeters to Gaussian noise has been studied and is predictable,⁴ provided the characteristics of the voltmeter are known.

²MIL STD-188B.

³Its use is suggested in ASA (now USASI) Standard S1.4, American Standard Specification for General-Purpose Sound-Level Meters (Jan. 9, 1961).

⁴Peterson, A. P. G., "Response of Peak Voltmeters to Random Noise," *The General Radio Experimenter*, December, 1956.

6.2.5 Measurement of Effective Bandwidth.

When wave analyzers or filters (or more complex systems) are used to measure the spectral density of noise, it is necessary to know the effective bandwidth of the filter or of the system. The effective noise bandwidth can be thought of in terms of an ideal filter having a rectangular frequency characteristic (constant over a range of frequencies, and zero everywhere else). The effective noise bandwidth of a filter is the width of the pass band of the ideal filter whose output is exactly equal to the output of the actual filter when the inputs are the same white noise, provided the maximum transmissions of the two filters are the same. It can be measured by finding the total signal transmitted when white noise of known spectral level is applied to the input. The frequency range of the white noise must include all frequencies for which the filter being measured has appreciable transmission.

When the effective bandwidth of the input noise is known, the necessary computations are simplified. Then the effective bandwidth of the filter is

$$EBW_f = EBW_n \left(\frac{N_{out}}{N_{in} G_{fmax}} \right)^2$$

where EBW_n is the effective bandwidth of the noise;

N_{out} is the output noise voltage;

N_{in} is the input noise voltage;

G_{fmax} is the maximum or peak gain of the filter (as measured with a sinewave signal).

The effective bandwidth of the white noise at the output of the Type 1382 Random-Noise Generator is approximately equal to 55.5 kHz.

6.2.6 Determining Impulse Response by Cross-Correlation.

The impulse response of an amplifier, network, or system is the cross-correlation function of its output and input when white noise is applied at the input. In practice, the bandwidth of the noise need only be large compared to the frequency-response range of the system under test. If apparatus for measuring the correlation function is available, this method is usually more satisfactory than applying an impulse (delta function) and observing the response directly, as the amplitude of the impulse may have to exceed the overload level to produce an observable signal at the output.

6.2.7 Observing Overload Characteristics.

To observe the effect of overloading an amplifier, it is sometimes desirable to use a signal with a high peak factor, to limit the total rms power. Trains of short rectangular pulses have been used for this purpose, but unless such a signal consists of short pulses of alternating polarity, it is highly unsymmetrical, and, for this reason, may produce undesirable effects. Random noise is a symmetrical signal that can be used for this

purpose. Gaussianly distributed noise, "white" over the audio band, has peaks greater than 4σ that occur often enough to be readily observable.

6.2.8 Broad-Band Testing or Burn-In.

When one wishes to test over-all performance of certain types of equipment, such as audio amplifiers, it may be desirable to use a broad-band signal so that the system is being exercised over its entire frequency range all at once.

The continuous spectrum of noise makes it ideal for this purpose. Clipping can be used to limit the peak amplitudes, permitting greater rms levels without overload.

It is also conceivable that certain types of electroacoustical equipment may require some sort of run-in or burn-in for which random noise may be the ideal test signal.

The spectrum of USASI noise resembles, to some extent, the average spectra of speech and music; thus, USASI noise may be particularly suitable for these purposes.

6.3 ACOUSTICAL AND PSYCHOACOUSTICAL TESTING.

6.3.1 Frequency-Response Measurements.

Frequency-response measurements of electroacoustic devices made with a sine-wave tone source, especially when made in nonanechoic surroundings, are frequently difficult to interpret because of the large fluctuations in the response curve due either to characteristics of the device or to standing-wave patterns. When the response of a loudspeaker in a particular room is measured, for example, fine details are of little significance, because they depend upon the precise placement of the source and receiver in the room. When this is the case, the curve can be made easier to interpret by using a band of noise in place of the sine-wave signal.⁵ The noise signal, in effect, averages the measurement over a range of frequencies, producing a smoother curve. A constant-bandwidth wave analyzer, such as the 1900,⁶ having the filtered output available, with white noise applied at its input, can produce a band of noise 50-Hz wide, tuneable across the audio-frequency range (with the exception of frequencies below 50 Hz). This band of noise can be amplified and applied to the loudspeaker as the test signal. The response curve can be recorded with the 1521 Graphic Level Recorder⁷ driving the tuning dial of the analyzer automatically, as in the 1910 Recording Wave Analyzer.

A constant-percentage-bandwidth analyzer, such as the 1564,⁸ with PINK noise applied at its input, produces, at its output, a noise signal of constant percentage bandwidth (such as one-third octave) and constant amplitude. Such a signal is equally useful in acoustical frequency-response measurements.

⁵Beranek, L. L., op. cit. pp. 665-666.

⁶General Radio Experimenter, Volume 38, No. 4, April, 1964.

⁷General Radio Experimenter, Volume 38, No. 9, Sept., 1964.

⁸General Radio Experimenter Reference, Vol. 37, Nos. 9 and 10, Sept.-Oct., 1963.

6.3.2 Measurements Under Reverberant Conditions.

A band of random noise, centered on the frequency of interest, is a very useful signal for measurements of reverberation time.^{9, 10} There are many acoustical measurements that are made under reverberant conditions, such as determination of the acoustical absorption of materials. In obtaining the diffuse-field response of a microphone. "It is practically mandatory that a random-noise source be used."¹¹

6.3.3 Sound-Transmission Measurements.

In measurements of the transmission of sound through panels, walls, and floors, random noise is often used, mainly because it is necessary to have a diffuse-sound field to obtain reproducible results. As mentioned above, the use of a random-noise signal is one of the best methods of obtaining a diffuse-sound field. Random noise is, again, a useful signal for measurement of sound attenuation in heating and air-conditioning ducts.

6.3.4 Psychoacoustical Testing.

Random noise is an important signal for psychoacoustical tests, such as masking or interference tests, loudness measurements, determination of critical bandwidths, and audiometric tests. The techniques used in making such tests are discussed in the various issues of the Journal of the Acoustical Society of America and in various psychological journals. There is a useful bibliography for these applications.¹²

6.4 VIBRATION TESTING.

The Type 1382 is a useful source of random noise for driving vibration generators (shakers) or loudspeakers for random vibration testing.^{5, 6} For the testing of large structures, however, the Type 1381 Random Noise Generator may be more convenient, as its spectrum is flat down to 2 Hz, its spectral level is higher at low frequencies, and clipping of the noise is available.

6.5 DEMONSTRATING STATISTICAL PROPERTIES.

6.5.1 Measurement of Amplitude Distribution.

An experimental method of measuring the amplitude distribution of random noise is presented in a General Radio

⁹ Beranek, L. L., op. cit. pp. 804-806.

¹⁰ General Radio Experimenter, Volume 38, No. 9, Sept., 1964.

¹¹ Beranek, L. L., op. cit. pp. 639-640.

¹² Stevens, S. S., Loring, J. G. S., and Cohen, Dorothy, Bibliography on Hearing, Harvard University Press, Cambridge, Mass., 1955; particularly those references listed in Sections 139 (p. 571), 157 (p. 573) and 222-228 (pp. 579f).

Student Experiment Note.¹³ The 1382 is particularly suitable for this purpose because its amplitude distribution is more accurately Gaussian than that of the Type 1390-B, called for in the note.

6.5.2 Demonstration of Correlation Theory.

In experiments on correlation theory, it is often necessary to generate two random signals having a known correla-

tion. Such signals can be generated easily with two 1382 Random-Noise Generators. The procedure for doing so is described in paragraph 5.7.

Correlation is properly measured by multiplying two signals together and averaging the result. When equipment for this purpose is not available, the degree of correlation between two random signals can be observed by means of oscillographic correlograms or scatterplots.¹⁴ These are substantially equivalent to Lissajous patterns for random signals.

¹³General Radio Co., Experiments for the Student Laboratory, "Distribution of Random Noise Voltages", No. STX-104 (Jan., 1967). A copy of this note can be obtained free of charge by writing to General Radio, West Concord, Mass., 01781.

¹⁴Licklider, J. C. R., and Dzendolet, E., "Oscillographic Scatterplots Illustrating Various Degrees of Correlation", Science, Vol. 107, No. 2770, p. 121-124 (Jan. 30, 1948).

Section 7—Service and Maintenance

7.1 WARRANTY.

We warrant that each new instrument manufactured and sold by us is free from defects in material and workmanship and that, properly used, it will perform in full accordance with applicable specifications for a period of two years after original shipment. Any instrument or component that is found within the two-year period not to meet these standards, after examination by our factory, District Office, or authorized repair agency personnel, will be repaired, or, at our option, replaced without charge, except for tubes or batteries that have given normal service.

7.2 SERVICE.

The two-year warranty stated above attests the quality of materials and workmanship in our products. When difficulties do occur, our service engineers will assist in any way possible. If the difficulty cannot be eliminated by use of the following service instructions, please write or phone our Service Department (see rear cover), giving full information of the trouble and of steps taken to remedy it. Be sure to mention the type and serial numbers of the instrument.

Before returning an instrument to General Radio for service, please write to our Service Department or nearest District Office, requesting a Returned Material Tag. Use of this tag will ensure proper handling and identification. For instruments not covered by the warranty, a purchase order should be forwarded to avoid unnecessary delay.

7.3 MINIMUM-PERFORMANCE STANDARDS.

A complete examination of a random-noise generator to determine conformance to operating specifications should include measurement of the spectrum and the amplitude distribution. These measurements are extremely difficult to make, requiring a number of items of specialized equipment. Measurement of the spectrum, for example, requires the use of analyzers tunable to frequencies as low as 20 Hz, having known detector characteristics (viz: true rms) and sufficiently long smoothing time following the detector to permit accurate measurements. Sufficient time must be spent in making the measurements to overcome the build-up in the long-time-constant smoothing filters.

Measurement of the amplitude distribution requires the use of an amplitude distribution analyzer, several models of which are commercially available, although they are not yet found in the average electronics laboratory. The 1382 Generators have been carefully checked for spectrum and amplitude distribution before leaving General Radio, and the following simple checks may be used for incoming inspection, to show that the noise generator is operating normally. The required test equipment is listed in Table 7-1.

TABLE 7-1

Test equipment required for checking minimum-performance standards.

INSTRUMENT	REQUIREMENTS	RECOMMENDED*
Ac Voltmeter	Sensitivity = 10 mV or less	Ballantine model 314A or equivalent (refer to paragraph 3.3.3).
Oscilloscope	Frequency range = 20 Hz – 2 MHz Sensitivity = 0.1 V/cm or less Bandwidth = 5 MHz or more Medium-persistence phosphor	

*Or equivalent.

a. Set the line-voltage switch, S502, at the rear of the instrument, for the appropriate line voltage. Connect the instrument to the line power: use the three-wire power cable supplied. Turn ON the POWER switch and set the NOISE SPECTRUM control to WHITE and the OUTPUT LEVEL control fully clockwise. Measure the output with a high-impedance electronic voltmeter (refer to Table 7-1). It should read approximately 3 volts, rms. (If this voltage is measured with an average-responding voltmeter, the voltmeter should indicate approximately 2.7 volts, as explained in paragraph 3.3.3.) Do not use a peak-responding voltmeter for this measurement. Turn the NOISE SPECTRUM control to PINK, then to USASI. The indication of the voltmeter should be about the same for all three spectra.

b. Connect an oscilloscope to the OUTPUT terminals. With the NOISE SPECTRUM control set at WHITE and the OUTPUT LEVEL control fully clockwise, occasional peaks of the noise voltage should be seen beyond 4σ (± 12 volts). The appearance of the noise should be perfectly symmetrical about the zero voltage level, i.e., substantially equal numbers of peaks in each direction should be observed.

7.4 TROUBLE ANALYSIS.

Table 7-2 lists the equipment required for trouble analysis.

When the instrument is not energized, the resistance from the collector of Q502 to ground, measured with the negative probe on ground, is approximately 2 kilohms. When the instrument is energized and operating normally, the power consumption is approximately 7 W.

Should the instrument fail to operate normally, use Table 7-3, to locate the source of the trouble.

TABLE 7-2

Test equipment required for trouble-analysis and recalibration procedures.

INSTRUMENT	REQUIREMENTS	RECOMMENDED*
Dc Voltmeter	20,000 Ω /V or more	Triplet Model 630A
Ohmmeter	—————	Simpson Model 260
Wattmeter	Indicates up to 10 W at 115 V	GR Variac adjustable autotransformer, Model W5MT3W
Wave Analyzer	Tuneable through vicinity of 150 kHz	Hewlett-Packard Model 310-A

*Or equivalent

7.5 RECALIBRATION.

If repairs are made that include the replacement of some components, the internal controls listed below may have to be readjusted (see Figures 7-1, 7-2, and 7-3). The required test equipment is noted in Table 7-2.

R103: Connect a Ballantine Model 314A Voltmeter (or equivalent) to measure the ac voltage with respect to ground at the emitter of Q103. The instrument should be at a temperature between 20 and 30°C. Adjust R103 so that the voltmeter indicates 100 mV.

R108: Connect the above-mentioned voltmeter to the OUTPUT terminals. Turn the NOISE SPECTRUM control to WHITE and the OUTPUT LEVEL control fully clockwise. Then set R108 so that the voltmeter indicates 3.3 V, rms, (3.0 V on an average-responding voltmeter). The output voltage should be at least 3.0 V, rms, (2.7 V on an average-responding voltmeter) when the NOISE SPECTRUM control is turned to PINK or USASI.

C130: In the event of replacement of Q111, Q112, or adjacent components, it may be necessary to set the local oscillator trap to exclude the local oscillator signal from the output. Use a wave analyzer that is tuneable to 150 kHz and adjacent frequencies. Find the local oscillator frequency (this may require detuning C125); then adjust C130 for a minimum indication at that frequency.

R513: For repairs to the voltage-regulator section of the power supply, it may be necessary to reset R513. Use a dc voltmeter and adjust R513 so that the dc voltage above ground (chassis) at the collector of Q502 is 31 V.

7.6 KNOB REMOVAL.

To remove the knob on a front-panel control, either to replace one that has been damaged or to replace the associated control, proceed as follows:

a. Grasp the knob firmly with the fingers, close into the panel (or the indicator dial, if applicable) and pull the knob straight, away from the panel.

CAUTION

Do not pull on the dial to remove a dial/knob assembly. Always remove the knob first.

TABLE 7-3
DC test voltages for trouble analysis.

LOCATION	DC VOLTS ABOVE GROUND	POSSIBLE LOCATION OF TROUBLE IF VOLTAGE IS OUTSIDE LIMITS
C503 +	+45 to +51 (with 115-V line)	Power cord not plugged in; Fuse F501 blown.
Collector, Q502	+31	Q501, Q502, Q503, CR506, or their associated circuits, etc.
Emitter, Q503	+14 to +16	Q501, Q502, Q503, CR506, etc.
Base, Q101	+12 to +14	CR101, Q101, etc.
Emitter, Q103	+0.6 to +0.8	Q102, Q103, etc.
Collector, Q103	+13 to +17	Q104, Q105, etc.
Collector, Q106	+13 to +17	Q106, etc.
Collector, Q111, Q112	+24 to +27	Q111, Q112, etc.
Emitter, Q113	+0.3 to +0.5	Q113, etc.
Collector, Q114	+8 to +12	Q113, Q114, etc.
Collector, Q116	+8 to +12	Q115, Q116, etc.
Collector, Q118	+14 to +18	Q117, Q118, etc.

b. Observe the position of the setscrew in the bushing with respect to any panel markings (or at the full CCW position of a continuous control).

c. Release the setscrew with an Allen wrench and pull the bushing off the shaft.

d. Remove and retain the black nylon thrust washer, behind the dial/knob assembly, as appropriate.

NOTE

To separate the bushing from the knob, if for any reason they should be combined off the instrument, drive a machine tap a turn or two into the bushing to provide sufficient grip for easy separation.

7.7 KNOB INSTALLATION.

To install a "Snap-on" knob assembly on the control shaft:

a. Place the black nylon thrust washer over the control shaft, if appropriate.

b. Mount the bushing on the shaft, using a small slotted piece of wrapping paper as a shim for adequate panel clearance.

c. Orient the setscrew on the bushing with respect to the panel-marking index and lock the setscrew with an Allen wrench.

NOTE

Make sure that the end of the shaft does not protrude through the bushing or the knob won't seat properly.

d. Place the knob on the bushing with the retention spring opposite the setscrew.

e. Push the knob in until it bottoms and pull it slightly to check that the retention spring is seated in the groove in the bushing.

NOTE

If the retention spring in the knob comes loose, re-install it in the interior notch with the small slit in the outer wall.

7.8 PILOT-LAMP REMOVAL.

To replace the pilot lamp (GE No. 328, GR P/N 5600-0300), remove the instrument from its cabinet and turn the instrument upside down. Insert a small screwdriver under the retaining strap at the rear of the lamp holder. Raise the end of the strap slightly and it will slide free, permitting the lamp to be withdrawn.

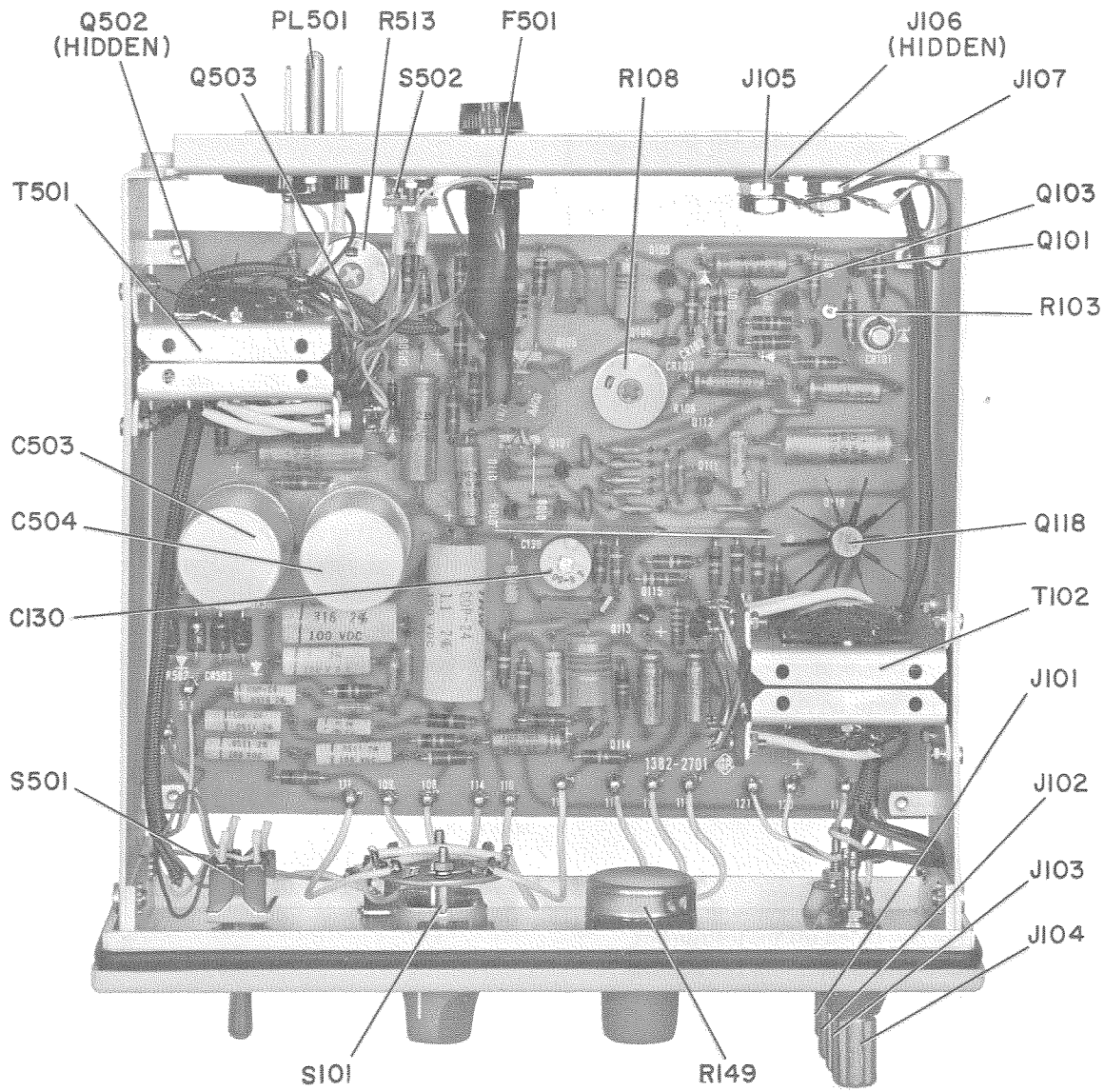

Figure 7-1.
Top interior view of the Generator.

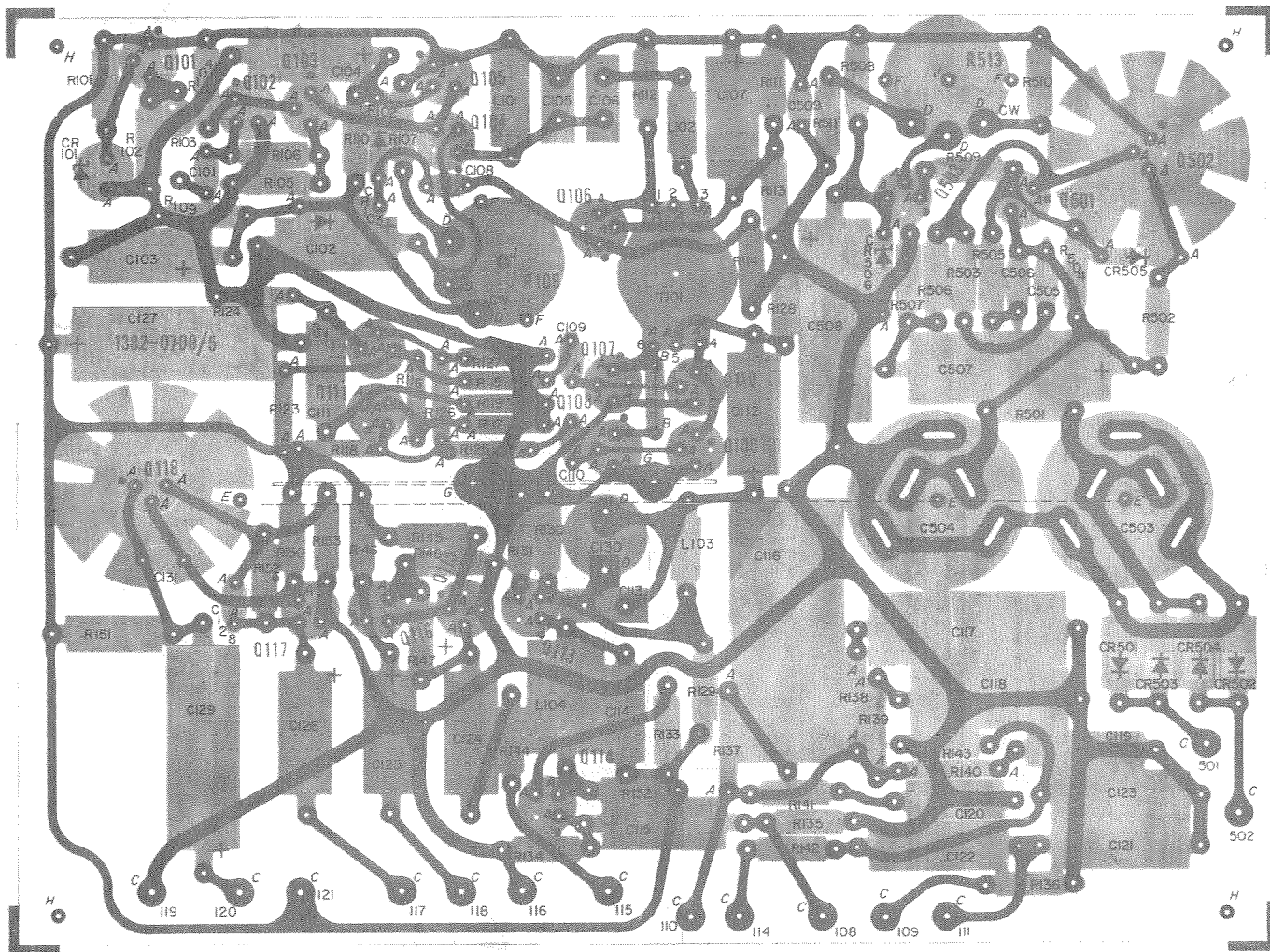

Figure 7-2.
Etched-circuit-board assembly. Complete board is P/N 1382-2701.

NOTE

The number shown on the foil side of the board is not the part number for the complete assembly. This assembly number is given in the caption.

The dot on the foil at the transistor socket indicates the collector lead.

1. POSITIVE SHOWN
2. CONTACT EXPLANATION SUPPLIER
3. REFERENCE TO APPEAR
4. RESISTOR

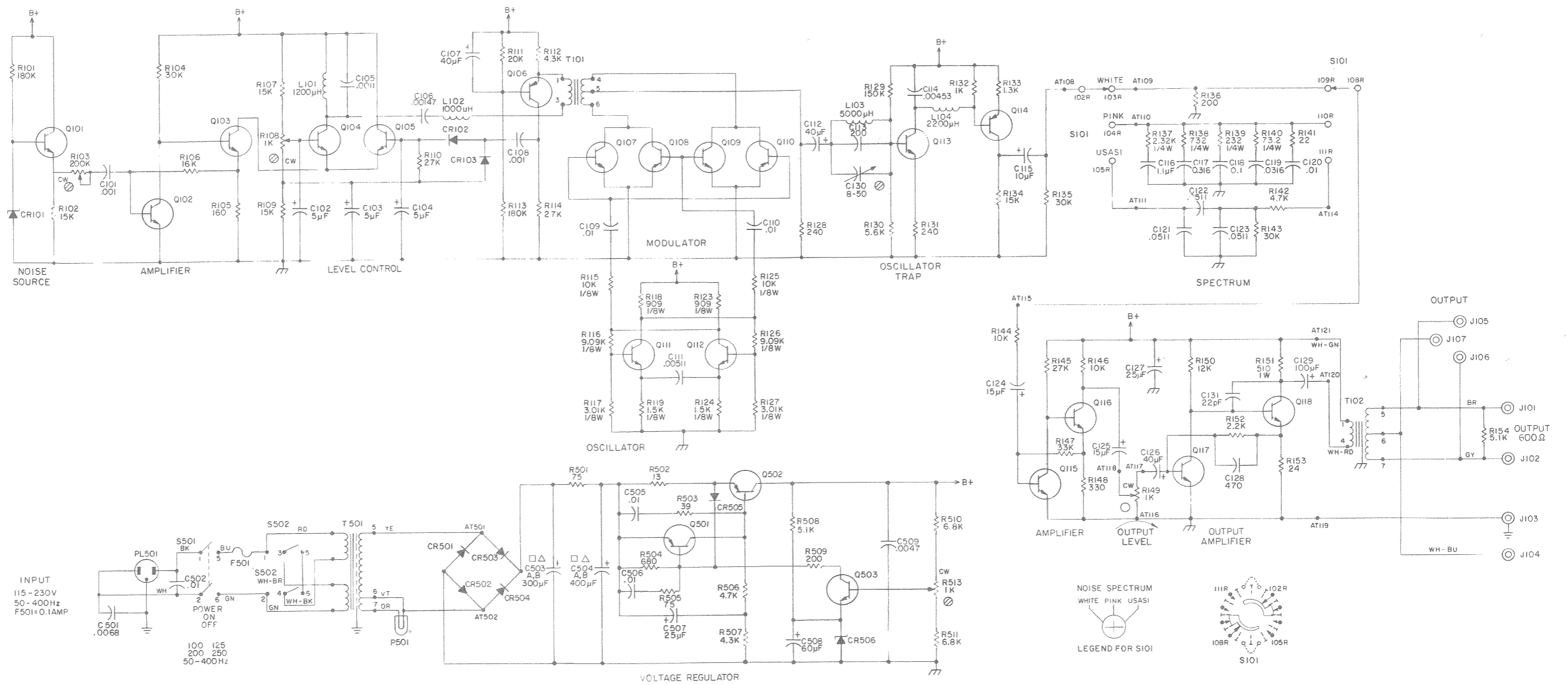
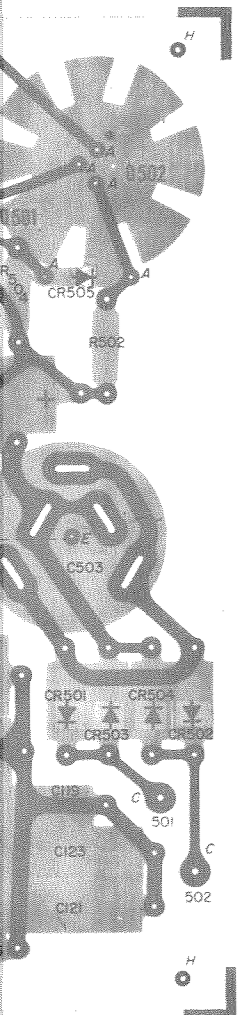

ANCHOR TERMINALS USED: 108 - 111, 114 - 121
501-503

- NOTE UNLESS SPECIFIED
1. POSITION OF ROTARY SWITCHES SHOWN COUNTERCLOCKWISE.
 2. CONTACT NUMBERING OF SWITCHES EXPLAINED ON SEPARATE SHEET SUPPLIED IN INSTRUCTION BOOK.
 3. REFER TO SERVICE NOTES IN INSTRUCTION BOOK FOR VOLTAGES APPEARING ON DIAGRAM.
 4. RESISTORS 1/2 WATT.
 5. RESISTANCE IN OHMS K - 1000 OHMS M - 1 MEGOHM
 6. CAPACITANCE VALUES ONE AND OVER IN PICO FARADS, LESS THAN ONE IN MICROFARADS.
 7. KNOB CONTROL
 8. SCREWDRIVER CONTROL
 9. AT - ANCHOR TERMINAL
 10. TP - TEST POINT

Rotary switch sections are shown as viewed from the panel end of the shaft. The first digit of the contact number refers to the section. The section nearest the panel is 1, the next section back is 2, etc. The next two digits refer to the contact. Contact 01 is the first position clockwise from a strut screw (usually the screw above the locating key), and the other contacts are numbered sequentially (02, 03, 04, etc), proceeding clockwise around the section. A suffix F or R indicates that the contact is on the front or rear of the section, respectively.

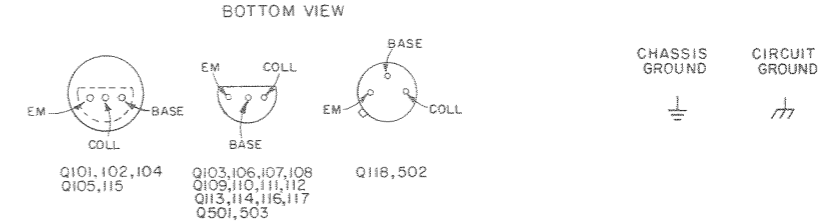

Figure 7-3. Schematic circuit diagram of the Type 1382 Random-Noise Generator.

PARTS LIST

Ref. Desig.	Description	GR Part No.	FMC	Mfg. Part No.	Fed. Stock No.
CAPACITORS					
C101	Ceramic, 0.001 μ F +80-20% 500 V	4404-2109	72982	831, 0.001 μ F +80-20%	5910-983-9994
C102	Electrolytic, 5 μ F +100-10% 50 V	4450-3900	37942	2040595S9C10X3	5910-448-5527
C103	Electrolytic, 5 μ F +100-10% 50 V	4450-3900	37942	2040595S9C10X3	5910-448-5527
C104	Electrolytic, 5 μ F +100-10% 50 V	4450-3900	37942	2040595S9C10X3	5910-448-5527
C105	Mica, 0.0011 μ F \pm 2% 100 V	4700-0683	14655	22 A, 0.0011 μ F \pm 2%	
C106	Mica, 0.00147 μ F \pm 2% 100 V	4700-0687	14655	22 A, 0.00147 μ F \pm 2%	
C107	Electrolytic, 40 μ F +100-10% 6 V	4450-3600	37942	20-40707S4	5910-952-0467
C108	Ceramic, 0.001 μ F +80-20% 500 V	4404-2109	72982	831, 0.001 μ F +80-20%	5910-983-9994
C109	Ceramic, 0.01 μ F +80-20% 500 V	4406-3109	72982	811, 0.01 μ F +80-20%	5910-977-7579
C110	Ceramic, 0.01 μ F +80-20% 500 V	4406-3109	72982	811, 0.01 μ F +80-20%	5910-977-7579
C111	Plastic, 0.00511 μ F \pm 1% 200 V	4860-7498	84411	663 UW, 0.00511 μ F	
C112	Electrolytic, 40 μ F +100-10% 6 V	4450-3600	37942	20-40707S4	5910-952-0467
C113	Mica, 200 pF \pm 5% 500 V	4700-0507	14655	22 A, 200 pF \pm 5%	
C114	Plastic, 0.00453 μ F \pm 2% 200 V	4860-7388	84411	663 UW, 0.00453 μ F	
C115	Electrolytic, 10 μ F +100-10% 25 V	4450-3800	56289	30D106G025BB4M1	5910-952-8658
C116	Plastic, 1.1 μ F \pm 2% 100 V	4860-8281	84411	GR9, 1.1 μ F \pm 2%	
C117	Plastic, 0.316 μ F \pm 2% 100 V	4860-7971	84411	GR9, 0.316 μ F	
C118	Plastic, 0.1 μ F \pm 2% 100 V	4860-8251	84411	663 UW, 0.1 μ F \pm 2%	
C119	Plastic, 0.0316 μ F \pm 2% 100 V	4860-7810	84411	GR8, 0.0316 μ F \pm 2%	
C120	Plastic, 0.01 μ F \pm 2% 100 V	4860-7650	84411	663 UW, 0.01 μ F \pm 2%	
C121	Plastic, 0.0511 μ F \pm 2% 100 V	4860-7829	84411	663 UW, 0.0511 μ F \pm 2%	
C122	Plastic, 0.0511 μ F \pm 2% 100 V	4860-7829	84411	663 UW, 0.0511 μ F \pm 2%	
C123	Plastic, 0.0511 μ F \pm 2% 100 V	4860-7829	84411	663 UW, 0.0511 μ F \pm 2%	
C124	Electrolytic, 15 μ F +100-10% 15 V	4450-3700	37942	TT, 15 μ F 15 V	
C125	Electrolytic, 15 μ F +100-10% 15 V	4450-3700	37942	TT, 15 μ F 15 V	
C126	Electrolytic, 40 μ F +100-10% 6 V	4450-3600	37942	20-40707S4	
C127	Electrolytic, 25 μ F +100-10% 50 V	4450-3000	56289	D33883	5910-799-9285
C128	Ceramic, 470 pF \pm 10% 500 V	4404-1478	72982	831, 479 pF \pm 10%	
C129	Electrolytic, 100 μ F +100-10% 15 V	4450-2800	56289	D17872	5910-034-5368
C130	Trimmer, 8-50 pF 350 V	4910-1170	72982	557-051, 8-50 pF	
C501	Ceramic, 0.0068 μ F +80-20% 500 V	4406-2689	72982	811, 0.0068 μ F +80-20%	
C502	Ceramic, 0.01 μ F +80-20% 500 V	4406-3109	72982	811, 0.01 μ F +80-20%	5910-977-7579
C503A					
C503B	Electrolytic, 150 μ F +100-10% 75 V	4450-5620	37942	20-222544990	5910-931-7040
C504A					
C504B	Electrolytic, 200 μ F +100-10% 50 V	4450-5591	80183	D38858	5910-959-4572
C505	Ceramic, 0.01 μ F +80-20% 500 V	4406-3109	72982	811, 0.01 μ F +80-20%	5910-977-7579
C506	Ceramic, 0.01 μ F +80-20% 500 V	4406-3109	72982	811, 0.01 μ F +80-20%	5910-977-7579
C507	Electrolytic, 25 μ F +100-10% 50 V	4450-3000	56289	D33883	5910-799-9285
C508	Electrolytic, 60 μ F +100-10% 25 V	4450-2900	80183	D17872	5910-799-9280
C509	Ceramic, 0.0047 μ F +80-20% 500 V	4405-2479	72982	801, 0.0047 μ F +80-20%	
DIODES					
CR101	Type ND012	6084-1014	84411	ND012	
CR102	Type 1N3604	6082-1001	24446	1N3604	5960-995-2199
CR103	Type 1N3604	6082-1001	24446	1N3604	5960-995-2199
CR501	Type 1N3253	6081-1001	79089	1N3253	5961-814-4251
CR502	Type 1N3253	6081-1001	79089	1N3253	5961-814-4251
CR503	Type 1N3253	6081-1001	79089	1N3253	5961-814-4251
CR504	Type 1N3253	6081-1001	79089	1N3253	5961-814-4251
CR505	Type 1N4009	6082-1012	24446	1N4009	
CR506	Type 1N965B	6083-1015	07910	1N965B	5960-877-6192
ETCHED CIRCUIT ASM. COMPLETE					
	Etched Circuit Asm. Complete	1382-2701	24655	1382-2701	
FUSE					
F501	0.1 A	5330-0400	71400	MDL, 0.1 A	5920-356-2185
INDUCTORS					
L101	1200 μ H \pm 5%	4300-7005	99800	2500-32, 1200 μ H \pm 5%	
L102	1000 μ H \pm 5%	4300-7000	99800	2500-28, 1000 μ H \pm 5%	
L103	5000 μ H \pm 10%	4300-5800	99800	3500-40, 5000 μ H \pm 10%	
L104	2200 μ H \pm 10%	4300-6370	99800	3500, 2200 μ H \pm 10%	
JACKS					
J101	Jack	0938-3000	24655	0938-3000	
J102	Jack	0938-3000	24655	0938-3000	
J103	Jack	0938-3032	24655	0938-3032	
J104	Jack	0938-3000	24655	0938-3000	
J105	Jack	4150-2700	24655	4150-2700	
J106	Jack	4150-2700	24655	4150-2700	
J107	Jack	4150-2700	24655	4150-2700	
KNOB ASM. NOISE SPECTRUM					
	Knob Asm. Noise Spectrum	5500-5221	24655	5500-5221	
KNOB ASM. OUTPUT LEVEL					
	Knob Asm. Output level	5520-5221	24655	5520-5221	
LAMP HOLDER SILK-SCREENED					
	Lamp holder silk-screened	5600-1023	24655	5600-1023	

PARTS LIST (Cont.)

Ref. Desig.	Description	GR Part No.	FMC	Mfg. Part No.	Fed. Stock No.
PILOT LIGHT					
P501	Pilot Light	5600-0300	24454	#328	6240-155-7857
PLUG					
PL501	Plug	4240-0600	24655	4240-0600	5935-816-0254
POWER CABLE					
	Power Cable	4200-9622	24655	4200-9622	6150-968-0081
RESISTORS					
R101	Composition, 180 kΩ ±5% 1/2 W	6100-4185	01121	RC20GF184J	5905-192-0660
R102	Composition, 15 kΩ ±5% 1/2 W	6100-3155	01121	RC20GF153J	5905-279-2616
R103	Composition, 8.2 kΩ ±5% 1/2 W	6100-2825	01121	RC20GF822J	5905-299-1971
R104	Composition, 30 kΩ ±5% 1/2 W	6100-3305	01121	RC20GF303J	5905-192-3978
R105	Composition, 330 Ω ±5% 1/2 W	6100-1335	01121	RC20GF331J	5905-192-3971
R106	Composition, 33 kΩ ±5% 1/2 W	6100-3335	01121	RC20GF333J	5905-171-1998
R107	Composition, 15 kΩ ±5% 1/2 W	6100-3155	01121	RC20GF153J	5905-279-2616
R108	Potentiometer, 1 kΩ ±10% 2 W	6056-0138	11236	Type 115, 1 kΩ ±10%	
R109	Composition, 15 kΩ ±5% 1/2 W	6100-3155	01121	RC20GF153J	5905-279-2616
R110	Composition, 27 kΩ ±5% 1/2 W	6100-3275	01121	RC20GF273J	5905-279-3499
R111	Composition, 20 kΩ ±5% 1/2 W	6100-3205	01121	RC20GF203J	5905-192-0649
R112	Composition, 4.3 kΩ ±5% 1/2 W	6100-2435	01121	RC20GF432J	5905-257-0935
R113	Composition, 180 kΩ ±5% 1/2 W	6100-4185	01121	RC20GF184J	5905-192-0660
R114	Composition, 27 kΩ ±5% 1/2 W	6100-3275	01121	RC20GF273J	5905-279-3499
R115	Film, 10 kΩ ±1% 1/8 W	6250-2100	75042	CEA, 10 kΩ ±1%	5905-883-4847
R116	Film, 18.2 kΩ ±1% 1/8 W	6250-2182	75042	CEA, 18.2 kΩ ±1%	5905-885-3373
R117	Film, 6.34 kΩ ±1% 1/8 W	6250-1634	75042	CEA, 6.34 kΩ ±1%	5905-855-3176
R118	Film, 909 Ω ±1% 1/8 W	6250-0909	75042	CEA, 909 Ω ±1%	
R119	Film, 1.5 kΩ ±1% 1/8 W	6250-1150	75042	CEA, 1.5 kΩ ±1%	5905-581-6913
R123	Film, 909 Ω ±1% 1/8 W	6250-0909	75042	CEA, 909 Ω ±1%	
R124	Film, 1.5 kΩ ±1% 1/8 W	6250-1150	75042	CEA, 1.5 kΩ ±1%	5905-581-6913
R125	Film, 10 kΩ ±1% 1/8 W	6250-2100	75042	CEA, 10 kΩ ±1%	5905-883-4847
R126	Film, 18.2 kΩ ±1% 1/8 W	6250-2182	75042	CEA, 18.2 kΩ ±1%	5950-686-3373
R127	Film, 6.34 kΩ ±1% 1/8 W	6250-1634	75042	CEA, 6.34 kΩ ±1%	5905-855-3176
R128	Composition, 240 Ω ±5% 1/2 W	6100-1245	01121	RC20GF241J	5905-279-2593
R129	Composition, 150 kΩ ±5% 1/2 W	6100-4155	01121	RC20GF154J	5905-279-2522
R130	Composition, 5.6 kΩ ±5% 1/2 W	6100-2565	01121	RC20GF562J	5905-195-6453
R131	Composition, 240 Ω ±5% 1/2 W	6100-1245	01121	RC20GF241J	5905-279-2593
R132	Composition, 1 kΩ ±5% 1/2 W	6100-2105	01121	RC20GF102J	5905-195-6806
R133	Composition, 1.3 kΩ ±5% 1/2 W	6100-2135	01121	RC20GF132J	5905-279-1870
R134	Composition, 15 kΩ ±5% 1/2 W	6100-3155	01121	RC20GF153J	5905-279-2616
R135	Composition, 30 kΩ ±5% 1/2 W	6100-3305	01121	RC20GF303J	5905-192-3978
R136	Composition, 200 Ω ±5% 1/2 W	6100-1205	01121	RC20GF201J	5905-279-2674
R137	Film, 2.32 kΩ ±1% 1/4 W	6350-1232	75042	CEB, 2.32 kΩ ±1%	5905-702-5989
R138	Film, 732 Ω ±1% 1/4 W	6350-0732	75042	CEB, 732 Ω ±1%	
R139	Film, 232 Ω ±1% 1/4 W	6350-0232	75042	CEB, 232 Ω ±1%	
R140	Film, 73.2 Ω ±1% 1/4 W	6350-9732	75042	CEB, 73.2 Ω ±1%	
R141	Composition, 22 Ω ±5% 1/2 W	6100-0225	01121	RC20GF220J	5905-279-3519
R142	Composition, 4.7 kΩ ±5% 1/2 W	6100-2475	01121	RC20GF472J	5905-279-3504
R143	Composition, 30 kΩ ±5% 1/2 W	6100-3305	01121	RC20GF303J	5905-192-3978
R144	Composition, 10 kΩ ±5% 1/2 W	6100-3105	01121	RC20GF103J	5905-185-8510
R145	Composition, 27 kΩ ±5% 1/2 W	6100-3275	01121	RC20GF273J	5905-279-3499
R146	Composition, 10 kΩ ±5% 1/2 W	6100-3105	01121	RC20GF103J	5905-185-8510
R147	Composition, 33 kΩ ±5% 1/2 W	6100-3335	01121	RC20GF333J	5905-171-1998
R148	Composition, 330 Ω ±5% 1/2 W	6100-1335	01121	RC20GF331J	5905-192-3971
R149	Potentiometer, 1 kΩ ±10%	6020-0250	01121	JA, 1 kΩ ±10%	
R150	Composition, 12 kΩ ±5% 1/2 W	6100-3125	01121	RC20GF123J	5905-279-3502
R151	Composition, 510 Ω ±5% 1/2 W	6110-1515	01121	RC32GF511J	5905-279-2656
R152	Composition, 2.2 kΩ ±5% 1/2 W	6100-2225	01121	RC20GF222J	5905-279-1876
R153	Composition, 24 Ω ±5% 1/2 W	6100-0245	01121	RC20GF240J	5905-279-1750
R154	Composition, 5.1 kΩ ±5% 1/2 W	6100-2515	01121	RC20GF512J	5905-279-2019
R501	Composition, 100 Ω ±5% 1/2 W	6100-1105	01121	RC20GF101J	5905-190-8889
R502	Composition, 20 Ω ±5% 1/2 W	6100-0205	01121	RC20GF200J	5905-279-3520
R503	Composition, 39 Ω ±5% 1/2 W	6100-0395	01121	RC20GF390J	5905-195-5546
R504	Composition, 680 Ω ±5% 1/2 W	6100-1685	01121	RC20GF681J	5905-195-6791
R505	Composition, 75 Ω ±5% 1/2 W	6100-0755	01121	RC20GF750J	5905-279-1758
R506	Composition, 4.7 kΩ ±5% 1/2 W	6100-2475	01121	RC20GF472J	5905-279-3504
R507	Composition, 4.3 kΩ ±5% 1/2 W	6100-2435	01121	RC20GF432J	5905-257-0935
R508	Composition, 5.1 kΩ ±5% 1/2 W	6100-2515	01121	RC20GF512J	5905-279-2019
R509	Composition, 200 Ω ±5% 1/2 W	6100-1205	01121	RC20GF201J	5905-279-2674
R510	Composition, 7.5 kΩ ±5% 1/2 W	6100-2755	01121	RC20GF752J	5905-249-4195
R511	Composition, 7.5 kΩ ±5% 1/2 W	6100-2755	01121	RC20GF752J	5905-249-4195
R513	Potentiometer, 1 kΩ ±10%	6056-0138	11236	Type 115, 1kΩ ±10%	
SWITCH TAG					
	Switch Tag	5301-0160	24655	5301-0160	

PARTS LIST (Cont.)

Ref. Desig.	Description	GR Part No.	FMC	Mfg. Part No.	Fed. Stock No.
SWITCHES					
S101	Switch	7890-4880	24655	7890-4880	
S501	Switch	7910-1300	04009	83053-SA	5930-909-3510
S502	Switch	7910-0831	42190	4603	
TRANSFORMERS					
T101	Transformer	5000-2021	24655	5000-2021	
T102	Transformer	0745-4550	24655	0745-4550	
T501	Transformer	0745-4500	24655	0745-4500	
TRANSISTORS					
Q101	Type 2N3391A	8210-1092	24454	2N3391A	
Q102	Type 2N3391A	8210-1092	24454	2N3391A	
Q103	Type 2N3903	8210-1132	93916	2N3903	
Q104	Type 2N3391A	8210-1092	24454	2N3391A	
Q105	Type 2N3391A	8210-1092	24454	2N3391A	
Q106	Type 2N3905	8210-1114	04713	2N3905	
Q107	Type 2N4123	8210-1123	93916	2N4123	
Q108	Type 2N4125	8210-1125	93916	2N4275	
Q109	Type 2N4123	8210-1123	93916	2N4123	
Q110	Type 2N4125	8210-1125	93916	2N4275	
Q111	Type 2N4123	8210-1123	93916	2N4123	
Q112	Type 2N4123	8210-1123	93916	2N4123	
Q113	Type 2N3903	8210-1132	93916	2N3903	
Q114	Type 2N3905	8210-1114	04713	2N3905	
Q115	Type 2N3391A	8210-1092	24454	2N3391A	
Q116	Type 2N3903	8210-1132	93916	2N3903	
Q117	Type 2N3903	8210-1132	93916	2N3903	
Q118	Type 2N697	8210-1040	82219	2N697	5961-752-0150
Q501	Type 2N3905	8210-1114	04713	2N3905	
Q502	Type 2N1131	8210-1025	96214	2N1131	5960-788-8644
Q503	Type 2N3903	8210-1132	93916	2N3903	
OTHER PARTS					
	Rack Adaptor Set	0480-9722	24655	0480-9722	
	Cabinet, Convertible - Bench	4181-2625	24655	4181-2625	
	Hardware Set (Tier)	4181-1111	24655	4181-1111	
	8 1/2" wide				
	Foot	5250-2120	24655	5250-2120	
	Foot	5250-2121	24655	5250-2121	
	Bail	5250-2123	24655	5250-2123	
	Foot	5260-2060	24655	5260-2060	
	O Ring	5855-0156	24655	5855-0156	
	Power Cable, 7 foot, 3-wire	4200-9622	24655	4200-9622	6150-968-0081
	Knob Assembly - Noise Spectrum	5500-5221	24655	5500-5221	
	Knob Assembly - Output level	5520-5221	24655	5520-5221	
	Lamp Holder Silk Screened	5600-1023	24655	5600-1023	
	Etched Circuit Assembly	1382-2701	24655	1382-2701	

FEDERAL MANUFACTURERS CODE

From Federal Supply Code for Manufacturers Cataloging Handbooks H4-1
(Name to Code) and H4-2 (Code to Name) as supplemented through June, 1967.

Code	Manufacturers Name and Address	Code	Manufacturers Name and Address	Code	Manufacturers Name and Address
00192	Jones Mfg. Co., Chicago, Illinois	49671	RCA, New York, N. Y.	80258	Standard Oil Co., Lafayette, Ind.
00194	Walsco Electronics Corp., Los Angeles, Calif.	49956	Raytheon Mfg. Co., Waltham, Mass. 02154	80294	Bourns Inc., Riverside, Calif. 92506
00656	Aerovox Corp., New Bedford, Mass.	53021	Sangamo Electric Co., Springfield, Ill. 62705	80431	Air Filter Corp., Milwaukee, Wisc. 53218
01009	Alden Products Co., Brockton, Mass.	54294	Shallcross Mfg. Co., Selma, N. C.	80583	Hammarlund Co. Inc., New York, N. Y.
01121	Allen-Bradley, Co., Milwaukee, Wisc.	54715	Shure Brothers, Inc., Evanston, Ill.	80740	Beckman Instruments, Inc., Fullerton, Calif.
01295	Texas Instruments, Inc., Dallas, Texas	56289	Sprague Electric Co., N. Adams, Mass.	81073	Grayhill Inc., LaGrange, Ill. 60525
02114	Ferroxcube Corp. of America, Saugerties, N. Y. 12477	59730	Thomas and Betts Co., Elizabeth, N. J. 07207	81143	Isolanite Mfg. Corp., Stirling, N. J. 07980
02606	Fenwal Lab. Inc., Morton Grove, Ill.	59875	TRW Inc. (Accessories Div), Cleveland, Ohio	81349	Military Specifications
02660	Amphenol Electronics Corp., Broadview, Ill.	60399	Torrington Mfg. Co., Torrington, Conn.	81350	Joint Army-Navy Specifications
02768	Fastex Division of Ill. Tool Works, Des Plaines, Ill. 60016	61637	Union Carbide Corp., New York, N. Y. 10017	81751	Columbus Electronics Corp., Yonkers, N. Y.
03508	G. E. Semiconductor Products Dept., Syracuse, N. Y. 13201	61864	United-Carr Fastener Corp., Boston, Mass.	81831	Filton Co., Flushing, L. I., N. Y.
03636	Grayburne, Yonkers, N. Y. 10701	63060	Victoreen Instrument Co., Inc., Cleveland, Ohio	81860	Barry Controls Div. of Barry Wright Corp., Watertown, Mass.
03888	Pyrofilm Resistor Co., Cedar Knolls, N. J.	63743	Ward Leonard Electric Co., Mt. Vernon, N. Y.	82219	Sylvania Electric Products, Inc. (Electronic Tube Div.), Emporium, Penn.
03911	Clairex Corp., New York, N. Y. 10001	65083	Westinghouse (Lamp Div), Bloomfield, N. J.	82273	Indiana Pattern and Model Works, LaPort, Ind.
04009	Arrow, Hart and Hegeman Electric Co., Hartford, Conn. 06106	65092	Weston Instruments, Weston-Newark, Newark, N. J.	82389	Switchcraft Inc., Chicago, Ill. 60630
04713	Motorola Semi-Conduct Product, Phoenix, Ariz. 85008	70485	Atlantic-India Rubber Works, Inc., Chicago, Ill. 60607	82647	Metals and Controls Inc., Attleboro, Mass.
05170	Engineered Electronics Co., Inc., Santa Ana, Calif. 92702	70563	Amperite Co., Union City, N. J. 07087	82807	Milwaukee Resistor Co., Milwaukee, Wisc.
05624	Barber-Colman Co., Rockford, Ill. 61101	70903	Belden Mfg. Co., Chicago, Ill. 60644	83058	Carr Fastener Co., Cambridge, Mass.
05820	Wakefield Eng., Inc., Wakefield, Mass. 01880	71126	Bronson, Homer D., Co., Beacon Falls, Conn.	83186	Victory Engineering Corp (IVECO), Springfield, N. J. 07081
07127	Eagle Signal Div. of E. W. Bliss Co., Baraboo, Wisc.	71294	Claiborn, H. O. Co., Clifton Forge, Va. 24422	83361	Bearing Specialty Co., San Francisco, Calif.
07261	Avnet Corp., Culver City, Calif. 90230	71400	Bussman Mfg. Div. of McGraw Edison Co., St. Louis, Mo.	83587	Solar Electric Corp., Warren, Penn.
07263	Faiachild Camera and Instrument Corp., Mountain View, Calif.	71590	Centralab, Inc., Milwaukee, Wisc. 53212	83740	Union Carbide Corp., New York, N. Y. 10017
07387	Birtcher Corp., No. Los Angeles, Calif.	71666	Continental Carbon Co., Inc., New York, N. Y.	84411	TRW Capacitor Div., Ogallala, Nebr.
07595	American Semiconductor Corp., Arlington Heights, Ill. 60004	71707	Coto Coil Co. Inc., Providence, R. I.	84835	Lehigh Metal Products Corp., Cambridge, Mass. 02140
07828	Bodine Corp., Bridgeport, Conn. 06605	71744	Chicago Miniature Lamp Works, Chicago, Ill.	84971	TA Mfg. Corp., Los Angeles, Calif.
07829	Bodine Electric Co., Chicago, Ill. 60618	71785	Cinch Mfg. Co. and Howard B. Jones Div., Chicago, Ill. 60624	86577	Precision Metal Products of Malden Inc., Stoneham, Mass. 02180
07910	Continental Device Corp., Hawthorne, Calif.	71823	Darnell Corp., Ltd., Downey, Calif. 90241	86684	RCA (Electrical Component and Devices) Harrison, N. J.
07983	State Labs Inc., N. Y., N. Y. 10003	72136	Electro Motive Mfg. Co., Willmington, Conn.	88140	Cutler-Hammer Inc., Lincoln, Ill.
07999	Amphenol Corp., Borg Inst. Div., Delavan, Wisc. 53115	72259	Nytronics Inc., Berkeley Heights, N. J. 07922	88219	Gould Nat. Batteries Inc., Trenton, N. J.
08730	Vemaline Prod. Co., Franklin Lakes, N. J.	72619	Dialight Co., Brooklyn, N. Y. 11237	88419	Cornell Dubilier Electric Corp., Fuquay-Varina, N. C.
09213	General Electric Semiconductor, Buffalo, N. Y.	72699	General Instrument Corp., Capacitor Div., Newark, N. J. 07104	88627	K and G Mfg. Co., New York, N. Y.
09408	Star-Tronics Inc., Georgetown, Mass. 01830	72765	Drake Mfg. Co., Chicago, Ill. 60656	89482	Holtzer Cabot Corp., Boston, Mass.
09823	Burgess Battery Co., Freeport, Ill.	72825	Hugh H. Eby, Inc., Philadelphia, Penn. 19144	89665	United Transformer Co., Chicago, Ill.
09922	Burndy Corp., Norwalk, Conn. 06852	72962	Elastic Stop Nut Corp., Union, N. J. 07083	90201	Mallory Capacitor Co., Indianapolis, Ind.
11236	C.P.S. of Berne, Inc., Berne, Ind. 46711	72982	Erie Technological Products Inc., Erie, Penn.	90750	Westinghouse Electric Corp., Boston, Mass.
11599	Chandler Evans Corp., W. Hartford, Conn.	73138	Beckman, Inc., Fullerton, Calif. 92634	90952	Hardware Products Co., Reading, Penn. 19602
12498	Teledyn Inc., Crystallines Div., Cambridge, Mass. 02140	73359	Amperex Electronics Co., Hicksville, N. Y.	91032	Continental Wire Corp., York, Penn. 17405
12672	RCA Commercial Receiving Tube and Semi- conductor Div., Woodridge, N.J.	73599	Carling Electric Co., W. Hartford, Conn.	91146	ITT Cannon Electric Inc., Salem, Mass.
12697	Clarostat Mfg. Co. Inc., Dover, N. H. 03820	73690	Elco Resistor Co., New York, N. Y.	91293	Johanson Mfg. Co., Boonton, N. J. 07005
12954	Dickson Electronics Corp., Scottsdale, Ariz.	73899	J. F. D. Electronics Corp., Brooklyn, N. Y.	91598	Chandler Co., Wethersfield, Conn. 06109
13327	Solitron Devices, Tappan, N. Y. 10983	74193	Heinemann Electric Co., Trenton, N. J.	91637	Dale Electronics Inc., Columbus, Nebr.
14433	ITT Semiconductors, W. Palm Beach, Florida	74861	Industrial Condenser Corp., Chicago, Ill.	91662	Elco Corp., Willow Grove, Penn.
14655	Cornell Dubilier Electric Co., Newark N. J.	74970	E. F. Johnson Co., Waseca, Minn. 56093	91719	General Instruments, Inc., Dallas, Texas
14674	Corning Glass Works, Corning, N. Y.	75042	IRC Inc., Philadelphia, Penn. 19108	91929	Honeywell Inc., Freeport, Ill.
14936	General Instrument Corp., Hicksville, N. Y.	75382	Kulka Electric Corp., Mt. Vernon, N. Y.	92519	Electra Insulation Corp., Woodside, Long Island, N. Y.
15238	ITT, Semiconductor Div. of Int. T. and T., Lawrence, Mass.	75608	Linden and Co., Providence, R. I.	92678	Edgerton, Germershausen and Grier, Boston, Mass.
15605	Cutler-Hammer Inc., Milwaukee, Wisc. 53233	75915	Littelfuse, Inc., Des Plaines, Ill. 60016	93332	Sylvania Electric Products, Inc., Woburn, Mass.
16037	Spruce Pine Mica Co., Spruce Pine, N. C.	76005	Lord Mfg. Co., Erie, Penn. 16512	93916	Cramer Products Co., New York, N. Y. 10013
19701	Electra Mfg. Co., Independence, Kansas 67301	76487	James Millen Mfg. Co., Malden, Mass. 02148	94144	Raytheon Co. Components Div., Quincy, Mass.
21335	Fafnir Bearing Co., New Britain, Conn.	76545	Mueller Electric Co., Cleveland, Ohio 44114	94154	Tung Sol Electric Inc., Newark, N. J.
24446	G. E. Schenectady, N. Y. 12305	76684	National Tube Co., Pittsburg, Penn.	95076	Garde Mfg. Co., Cumberland, R. I.
24454	G. E., Electronic Comp., Syracuse, N. Y.	76854	Oak Mfg. Co., Crystal Lake, Ill.	95146	Alco Electronics Mfg. Co., Lawrence, Mass.
24455	G. E. (Lamp Div), Nela Park, Cleveland, Ohio	77147	Patton MacGuer Co., Providence, R. I.	95238	Continental Connector Corp., Woodside, N. Y.
24655	General Radio Co., W. Concord, Mass 01781	77166	Pass-Seymour, Syracuse, N. Y.	95275	Vitramon, Inc., Bridgeport, Conn.
26806	American Zettler Inc., Costa Mesa, Calif.	77263	Pierce Roberts Rubber Co., Trenton, N. J.	95354	Methode Mfg. Co., Chicago, Ill.
28520	Hayman Mfg. Co., Kenilworth, N. J.	77339	Positive Lockwasher Co., Newark, N. J.	95412	General Electric Co., Schenectady, N. Y.
28959	Hoffman Electronics Corp., El Monte, Calif.	77542	Ray-O-Vac Co., Madison, Wisc.	95794	Ansonda American Brass Co., Torrington, Conn.
30074	International Business Machines, Armonk, N.Y.	77630	TRW, Electronic Component Div., Camden, N. J. 08103	96095	Hi-Q Div. of Aerovox Corp., Orlean, N. Y.
32001	Jensen Mfg. Co., Chicago, Ill. 60638	77638	General Instruments Corp., Brooklyn, N. Y.	96214	Texas Instruments Inc., Dallas, Texas 75209
35929	Constanta Co. of Canada Limited, Montreal 19, Quebec	78189	Shakeproof Div. of Ill. Tool Works, Elgin, Ill. 60120	96256	Thordarson-Meissner Div. of McGuire, Mt. Carmel, Ill.
37942	P. R. Mallory and Co. Inc., Indianapolis, Ind.	78277	Sigma Instruments Inc., S. Braintree, Mass.	96341	Microwave Associates Inc., Burlington, Mass.
38443	Marlin-Rockwell Corp., Jamestown, N. Y.	78488	Stackpole Carbon Co., St. Marys, Penn.	96906	Military Standards
40931	Honeywell Inc., Minneapolis, Minn. 55408	78553	Tinnerman Products, Inc., Cleveland, Ohio	97966	CBS Electronics Div. of Columbie Broadcast- ing Systems, Danvers, Mass.
42190	Muter Co., Chicago, Ill. 60638	79089	RCA, Commercial Receiving Tube and Semi- conductor Div., Harrison, N. J.	98291	Sealectro Corp., Mamaroneck, N. Y. 10544
42498	National Co. Inc., Melrose, Mass. 02176	79725	Wiremold Co., Hartford, Conn. 06110	98821	North Hills Electronics Inc., Glen Cove, N. Y.
43991	Norma-Hoffman Bearings Corp., Stanford, Conn. 06904	79963	Zierick Mfg. Co., New Rochelle, N. Y.	99180	Transitron Electronics Corp., Melrose, Mass.
		80030	Prestolite Fastener Div. Bishop and Babcock Corp., Toledo, Ohio	99378	Atlee Corp., Winchester, Mass. 01890
		80048	Vickers Inc. Electric Prod. Div., St. Louis, Mo.	99800	Delevan Electronics Corp., E. Aurora, N. Y.
		80131	Electronic Industries Assoc., Washington, D.C.		
		80211	Motorola Inc., Franklin Park, Ill. 60131		

THE GENERAL RADIO SOUND- AND VIBRATION-MEASURING LINE.

