

**FLUKE®**

# Instruction Manual

## Model Y5020

Current Shunt

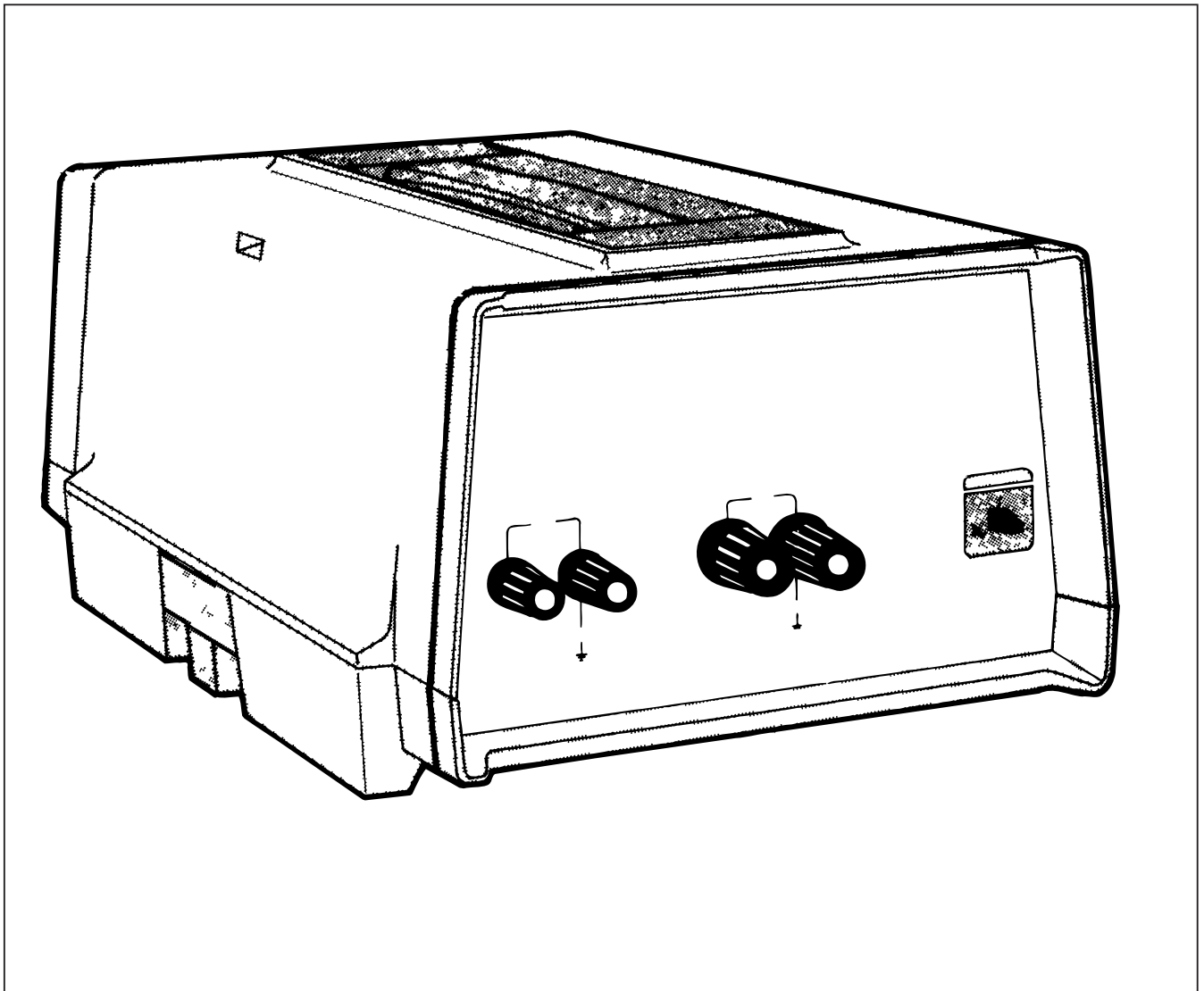

P/N 516591 September 1979

## WARRANTY

Notwithstanding any provision of any agreement the following warranty is exclusive:

The JOHN FLUKE MFG. CO., INC., warrants each instrument it manufactures to be free from defects in material and workmanship under normal use and service for the period of 1-year from date of purchase. This warranty extends only to the original purchaser. This warranty shall not apply to fuses, disposable batteries (rechargeable type batteries are warranted for 90-days), or any product or parts which have been subject to misuse, neglect, accident or abnormal conditions of operations.

In the event of failure of a product covered by this warranty, John Fluke Mfg. Co., Inc., will repair and calibrate an instrument returned to an authorized Service Facility within 1 year of the original purchase; provided the warrantor's examination discloses to its satisfaction that the product was defective. The warrantor may, at its option, replace the product in lieu of repair. With regard to any instrument returned within one year of the original purchase, said repairs or replacement will be made without charge. If the failure has been caused by misuse, neglect, accident or abnormal conditions of operations, repairs will be billed at a nominal cost. In such case, an estimate will be submitted before work is started, if requested.

THE FOREGOING WARRANTY IS IN LIEU OF ALL OTHER WARRANTIES, EXPRESS OR IMPLIED, INCLUDING BUT NOT LIMITED TO ANY IMPLIED WARRANTY OF MERCHANTABILITY, FITNESS OR ADEQUACY FOR ANY PARTICULAR PURPOSE OR USE. JOHN FLUKE MFG. CO., INC., SHALL NOT BE LIABLE FOR ANY SPECIAL, INCIDENTAL OR CONSEQUENTIAL DAMAGES, WHETHER IN CONTRACT, TORT OR OTHERWISE.

### If any failure occurs, the following steps should be taken:

1. Notify the JOHN FLUKE MFG. CO., INC., or the nearest Service facility, giving full details of the difficulty, and include the Model number, type number, and serial number. On receipt of this information, service data or shipping instructions will be forwarded to you.
2. On receipt of the shipping instructions, forward the instrument, transportation prepaid. Repairs will be made at the Service Facility and the instrument returned, transportation prepaid.

### SHIPPING TO MANUFACTURER FOR REPAIR OR ADJUSTMENT

All shipments of JOHN FLUKE MFG. CO., INC., instruments should be made via United Parcel Service or "Best Way" prepaid. The instrument should be shipped in the original packing carton; or if it is not available, use any suitable container that is rigid and of adequate size. If a substitute container is used, the instrument should be wrapped in paper and surrounded with at least four inches of excelsior or similar shock-absorbing material.

### CLAIM FOR DAMAGE IN SHIPMENT TO ORIGINAL PURCHASER

The instrument should be thoroughly inspected immediately upon original delivery to purchaser. All material in the container should be checked against the enclosed packing list. The manufacturer will not be responsible for shortages against the packing sheet unless notified immediately. If the instrument is damaged in any way, a claim should be filed with the carrier immediately. (To obtain a quotation to repair shipment damage, contact the nearest Fluke Technical Center.) Final claim and negotiations with the carrier must be completed by the customer.

The JOHN FLUKE MFG. CO., INC. will be happy to answer all application or use questions, which will enhance your use of this instrument. Please address your requests or correspondence to: JOHN FLUKE MFG. CO., INC., P.O. BOX 43210, MOUNTLAKE TERRACE, WASHINGTON 98043, ATTEN: Sales Dept. For European Customers: Fluke (Nederland) B.V., Zevenheuvelenweg 53, Tilburg, The Netherlands.

\* For European customers, Air Freight prepaid.

**John Fluke Mfg. Co., Inc., • P.O. Box 43210 • Mountlake Terrace, Washington 98043**

## INTRODUCTION

The Model Y5020 is a precision, four-terminal, current shunt designed for use in calibrating ac/dc current sources in the range of 0 to 20 amps, do to 5 kHz. The shunt is housed in a forced-air cooled, PTI (Portable Test Instrument) case. This case is compatible with all instruments in the Fluke PTI product line and can be stacked with other PTI products to form a portable test system.

Forced-air cooling is accomplished by a fan mounted on the rear panel. Air is pulled in through the fan, passed over the shunt, and exhausted through the rear panel. Power for the fan is derived from the power line. Two voltage configurations are available, 115 or 230V ac  $\pm 10\%$ , 50 to 60 Hz.

Four front panel terminals provide electrical access to the shunt; two are current input terminals and two are voltage output (sense) terminals. When the shunt is connected into a circuit and operating at its maximum current limit (20 amps), the input connections and the shunt present a burden voltage of less than 0.25V dc.

## SPECIFICATIONS

Specifications for the Y5020 Current Shunt are given in Table 1.

## INSTALLATION

The Y5020 PTI case is designed to stack with other Fluke instruments in the PTI product line. Use the following procedure to stack the Y5020 with the other PTI instruments.

1. Locate and pull the black latches on both sides of the unit to their extended position.
2. Place the unit on top of the PTI stack with the front panel toward the front of the stack.
3. When the unit is properly seated push both latches to the in position. This will lock the Y5020 to the stack.

## CONTROLS AND CONNECTORS

The front- and rear-panel controls and connectors on the Y5020 are shown in Figure 1 and described in Table 2.

## OPERATING NOTES

### Input Power

Line power requirements for the Y5020 are specified on a decal located on the bottom side of the unit. These include line voltage requirements (115V or 230V ac  $\pm 10\%$ , 50 to 60 Hz) and replacement fuse types. Input power is used solely to power an internal cooling fan. A front panel POWER switch allows the fan to be turned on and off.

### Fuse Replacement

The Y5020 includes a fuse to protect the ac power line from an accidental overload. If replacement is required, use a 1/8 amp, 250 volt (AGC) fuse. Use the following procedure to replace the fuse:

1. Set the POWER switch to OFF and disconnect the unit from line power.
2. Locate the fuse holder on the rear panel.

**Table 1. Y5020 Specifications**

NOMINAL RESISTANCE	0.01 $\Omega$ $\pm 1\%$
ACCURACY OF CALIBRATION VALUE	$\pm 0.01\%$
DC	$\pm 0.01\%$
DC to 1 kHz	$\pm 0.025\%$
1 kHz to 5 kHz	$\pm 0.035\%$
STABILITY OF CALIBRATION VALUE	(30 ppm per 6 months)
MAXIMUM CURRENT	20A dc or rms ac
BURDEN VOLTAGE AT 20 AMPS	Less than 0.25V
TEMPERATURE COEFFICIENT	$\leq 0.001\%$ per $^{\circ}\text{C}$
POWER COEFFICIENT	$\leq 0.005\%$ at 20 amps
POWER	115V ac $\pm 10\%$ or 230V ac $\pm 10\%$ , 11 watts for cooling fan.
PROTECTION CLASS 3	Relates solely to insulating or grounding properties as defined in IEC 348.

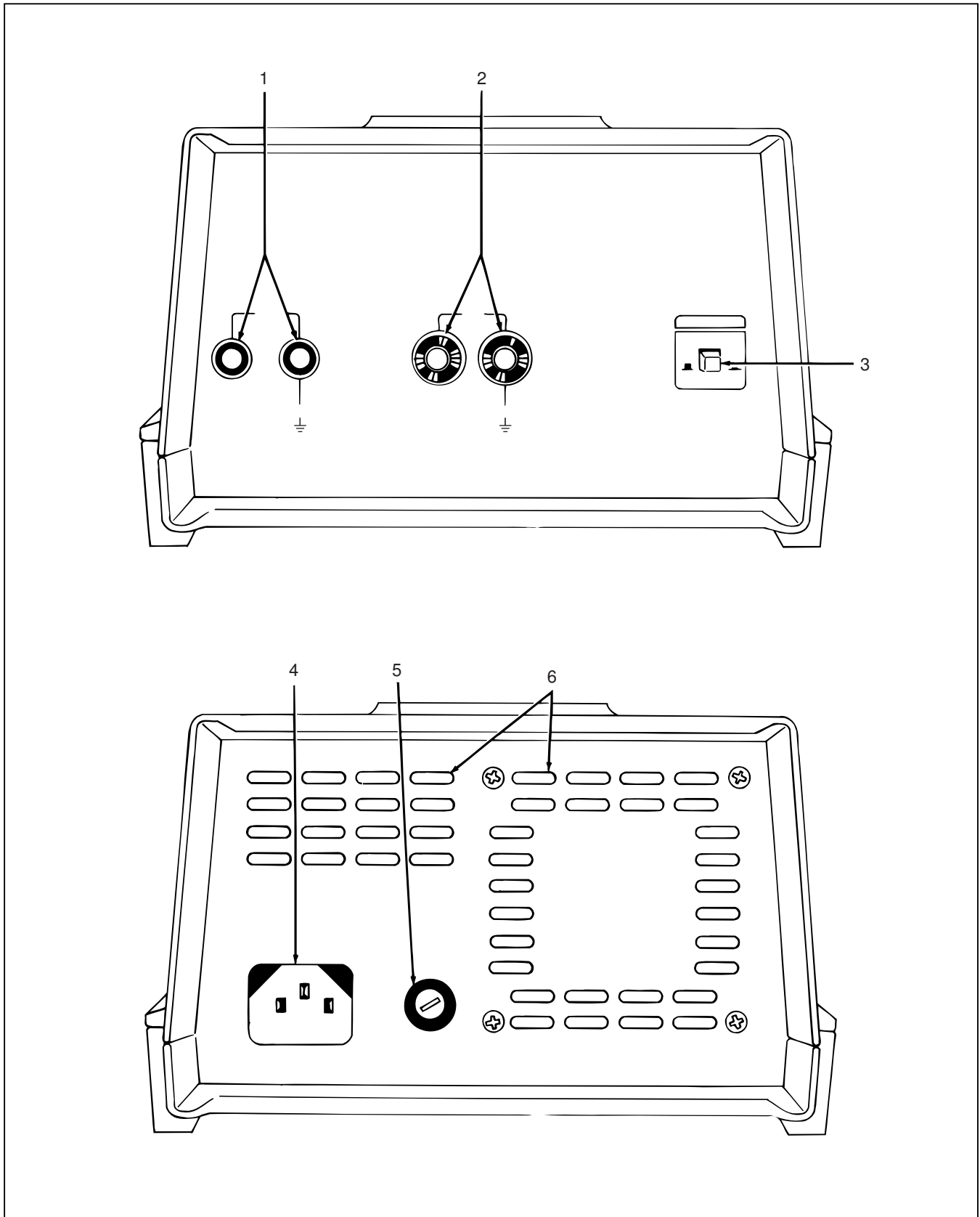

Figure 1. Controls and Connectors

Table 2. Controls and Connectors

REF NO.	NAME	FUNCTION
1	VOLTAGE OUTPUT Terminals	A pair of binding posts that serve as the sense connections to the four-terminal shunt. The maximum sense voltage at 20 amps is 0.2 volts.
2	CURRENT INPUT Terminals	Two binding posts that serve as the current input connections to the shunt. The maximum current rating for the shunt is 20 amps.
3	POWER Switch	A push-push type switch used to switch the cooling fan on and off.
4	Input Power Connector	A three-prong connector used to connect the instrument (via the power cord) to line power.
5	Fuse Holder	Holds the line power fuse for the cooling fan. The fuse provides ac input protection from overloads.
6	Fan Intake and Exhaust Ports	Cooling air for the shunt is pulled in through the rear-right port (intake) and exhausted through the rear-left port. The fan is located behind the intake port.

- Release the fuse by pressing in on the fuse cap and turning it 1/8 of a turn counterclockwise. Use a suitable screwdriver.

### CAUTION

**To avoid fire hazard use only a 1/8 amp, 250 volt (AGC) fuse replacement.**

- Install the new fuse in the fuse cap and install both in the fuse holder.

### Forced-Air Cooling

#### CAUTION

**To ensure the accuracy specifications of the shunt, do not apply input current to the Y5020 unless the cooling fan is energized.**

The Y5020 is equipped with an internal cooling fan to ensure the accuracy and stability of the shunt over its operating range (0 to 20 amps). The fan pulls the air in through the rear panel, passes it over the shunt, and exhausts it through the rear panel. Power for the fan is derived from the ac power line. A front panel POWER switch is used to turn the fan off and on.

### Four-Terminal Measurements

The Y5020 is a four-terminal current shunt. Two terminals (CURRENT INPUT) are used to carry the current to be measured. The other two (VOLTAGE OUTPUT) are

voltage sense terminals and are not designed to carry any measurement current. These sense terminals are connected directly across the shunt.

When current is passed through the shunt, the IR drop developed across it can be read at the VOLTAGE OUTPUT terminals using a high impedance voltmeter (>10 MW). Since this voltage reading does not include the IR drop of the current carrying conductors leading up to the shunt, it provides an accurate indication of the current flowing through the shunt.

### Nominal Shunt Resistance

The current shunt used in the Y5020 has a nominal resistance value of 0.01 ohms. This value was selected for two reasons. First, the low resistance minimizes the voltage drop (burden voltage) developed across the shunt. As a result, the shunt has a negligible affect on the circuit into which it is inserted. Second, the voltage drop across the shunt relates directly to the current flowing through it. For example, a current of 1 amp will produce a .01 volt output. This relationship is linear over the current range (0 to 20 amps).

### Actual Shunt Value

The actual resistance value of the shunt is recorded in the lower-right corner of the Y5020 front panel. This value is traceable to the National Bureau of Standards, and must be considered when required current accuracy is better than 1 percent.

## Voltmeter Requirements

Accurate current measurements require the use of a highimpedance (>10 MΩ) digital voltmeter to measure the shunt voltage appearing at the OUTPUT TERMINALS. In addition, the voltmeter should have a voltage accuracy of at least ±0.01%, and be capable of resolving 10 μV on a 200 μV range. The use of a voltmeter that does not meet or exceed these requirements will degrade the accuracy of the current measurement.

## Current Calculation

Precise current measurements require that the current value be calculated using the SHUNT VALUE and the voltage present at the VOLTAGE OUTPUT terminals; i.e.,  $I = \text{VOLTAGE OUTPUT} / \text{SHUNT VALUE}$ . For example:

$$\text{SHUNT VALUE} = .0100363$$

$$\text{VOLTAGE OUTPUT} = .050182$$

$$\text{Current} = .050182 / .0100363 = 5.0000498 \text{ amps}$$

## OPERATION

With reference to the previous paragraphs use the following procedure to operate the Y5020:

1. Connect the Y5020 to the line power and set the POWER switch to ON.
2. Connect a suitable voltmeter (ac or dc) to the VOLTAGE OUTPUT terminals, observe polarity.
3. Select the 200 mV range on the voltmeter.
4. Remove power from the circuit to be measured and connect the Y5020 (as if it were an ammeter) into the circuit using the CURRENT INPUT terminals. Observe polarity.
5. Energize the circuit under test and derive the measurement current using the SHUNT VALUE and the voltmeter reading.

## THEORY OF OPERATION

The Y5020 Current Shunt, as shown in Figure 2, is a precision, four-terminal current shunt designed for use in measuring ac/dc current in the range of 0 to 20 amps, dc to 5 kHz. Measurement current is connected at the CURRENT INPUT terminals and passed through the shunt resistor. The voltage drop developed across the shunt is picked off at the shunt sense terminal and carried to the front panel VOLTAGE OUTPUT terminals.

Current flowing through the shunt is directly proportional to the voltage present at the VOLTAGE OUTPUT terminals, i.e.  $I = E / R$ .

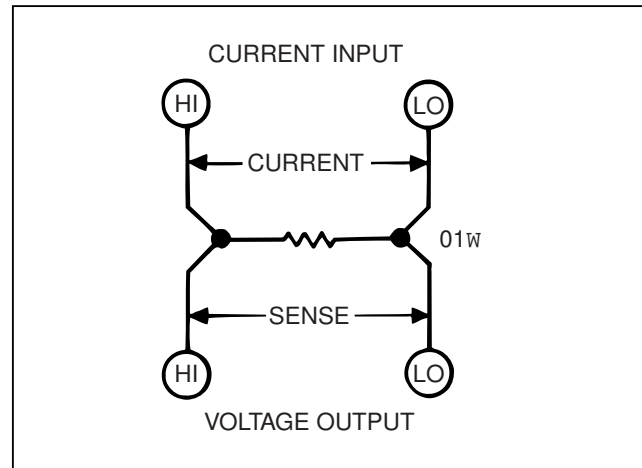

Figure 2. Current Shunt

## MAINTENANCE

### Access/Disassembly

To access the interior of the Y5020 remove the four screws on the bottom of the unit and pull the top cover from the bottom cover. All components are accessible with the top cover removed.

The shunt is a plug-in assembly and may be pulled out for inspection, repair and/or replacement. Do not bend the shunt elements during the removal process.

### Calibration

The Y5020 is not equipped with any calibration adjustments. However, the SHUNT VALUE given on the front panel should be verified every 180 days by a calibration facility with NBS traceability.

## LIST OF REPLACEABLE PARTS

A list of replaceable parts for the Y5020 is given in Table 3. Components are listed alphanumerically by assembly. Electrical and mechanical components are listed by reference designator. Each listed part is shown in an accompanying illustration.

Parts may be ordered directly from the manufacturer by using the manufacturer's part number or from the John Fluke Mfg. Co., Inc. factory or authorized representative by using the FLUKE Stock Number. If an ordered part has been replaced by a new or improved part, the replacement will be accompanied by an explanatory note and installation instructions, if necessary.

To ensure prompt, efficient handling of your order, include the following information:

1. Quantity.
2. FLUKE Stock Number.
3. Description.
4. Reference Designation.

5. Printed Circuit Board Part Number and Revision Letter.

6. Instrument Model and Serial Number.

### SCHEMATIC DIAGRAM

A schematic diagram of the Y5020 is shown in Figure 4.

Table 3. Y5020 Final Assembly

REF DES	DESCRIPTION	FLUKE STOCK NO.	MFG SPLY CODE	MFG PART NO. OR TYPE	TOT QTY	REC QTY	NO TE
A	Y5020 CURRENT SHUNT FINAL ASSEMBLY						
	FIGURE 3 (Y5020-5001)						
A1	TERMINATOR PCB ASSEMBLY	489930	89536	489930	1		
B1	FAN, VENTURI, SUB-MINIATURE 230V FAN	ORDER	FOR	APPLICABLE SOURCE	1		
	115V FAN	513465	82877	SU3A1			
F1	FUSE, FAST-ACT, 1/8 AMP, 250V	335083	82877	5P2A2			
		196790	71400	AGC1-8	1		5
H1	NUT, HEX, 4-40	110635	89536	110635	7		
H2	NUT, HEX, 6-32	110551	89536	110551	6		
H3	SCREW, RHP, 4-40 X 5/8	145813	89536	145813	2		
H4	SCREW, THREAD-FORM, 6-20 X 3/8	288266	89536	288266	1		
H5	SCREW, METRIC, 6MM	380626	89536	380626	6		
H6	SCREW, PHP, SEMS, 6-32 X 1/4	178533	89536	178533	8		
H7	SCREW, PHP, 6-32 X 3/8	152165	89536	152165	4		
H8	SCREW, FHP, 6-32 X 5/8	114876	89536	114876	6		
H9	WASHER, INT/LOCK #2	110718	89536	110718	2		
H10	WASHER, INT/LOCK, #6	110338	89536	110338	4		
H11	WASHER, SPLIT/LK #6	110692	89536	110692	2		
H12	FUSE CLIP	101352	71400	5681-15	2		
J1	CONN, AC POWER BULKHEAD RECEPT.	284166	82389	EAC301	1		
J2	BINDING POST, 5-WAY, 30 AMP, RED	142976	58474	DF-31RC	1		
J3	JACK/PLUG, BANANA	101550	89536	101550	4		
J4	BINDING POST, PANEL, RED	275552	32767	820-65	1		
J5	BINDING POST, PANEL, BLACK	275560	32767	820-45	1		
MP1	BAIL STAND	467555	89536	467555	1		
MP2	BASE, STANDARD	454702	89536	454702	1		
MP3	BOARD, MOUNTING	514877	89536	514877	1		
MP4	BRACKET, POWER SWITCH	514869	89536	514869	1		
MP5	BUTTON, GREEN (TO S1)	445197	89536	4445197	1		
MP6	CLAMP, CABLE/STRAP, 4 INCH	172080	06383	SST-1M	3		
MP7	COVER, D SIZE	454744	89536	454744	1		
MP8	DECAL, BASE SIDES	473652	89536	473652	2		
MP9	DECAL, FRONT PANEL	508358	89536	508358	1		
MP10	DECAL, REAR SERIAL NAMEPLATE	472795	89536	472795	1		
MP11	DECAL, RETAINER	473645	89536	473645	2		
MP13	DECAL, SPECIFICATION	508341	89536	508341	1		
MP14	FOOT, NON-SKID	467571	89536	467571	4		
MP15	HANDLE	454751	89536	454751	1		

Table 3. Y5020 Final Assembly (cont)

REF DES	DESCRIPTION	FLUKE STOCK NO.	MFG SPLY CODE	MFG PART NO. OR TYPE	TOT QTY	REC QTY	NOTE
MP16	HANDLE, RETAINER	467563	89536	467563	2		
MP17	INPUT BUS, HI	514885	89536	514885	1		
MP18	INPUT BUS, LO	514893	89536	514893	1		
MP19	LATCH	467548	89536	467548	2		
MP20	PLUG/JACK	101550	71002	403	4		
MP21	PANEL, FRONT	514844	89536	514844	1		
MP22	PANEL, REAR	514851	89536	514851	1		
MP23	SPACER, W/#6 SCREW, ALUM.	144311	89536	144311	2		
MP24	LUG, SOLDER, #124	102558	89536	102558	3		
R1	SHUNT ASSEMBLY	491290	89536	491290	1		
S1	SWITCH, POWER, DPDT	291526	89536	291526	1		
TM1	INSTRUCTION MANUAL, Y5020 (NOT SHOWN)	516591	89536	516591			
W1	CORDSET, 3-WIRE, 7 1/2 FT.	363481	89536	363481	1		
XF1	FUSEHOLDER, BODY, CAP & NUT	424416	89536	424416	1		



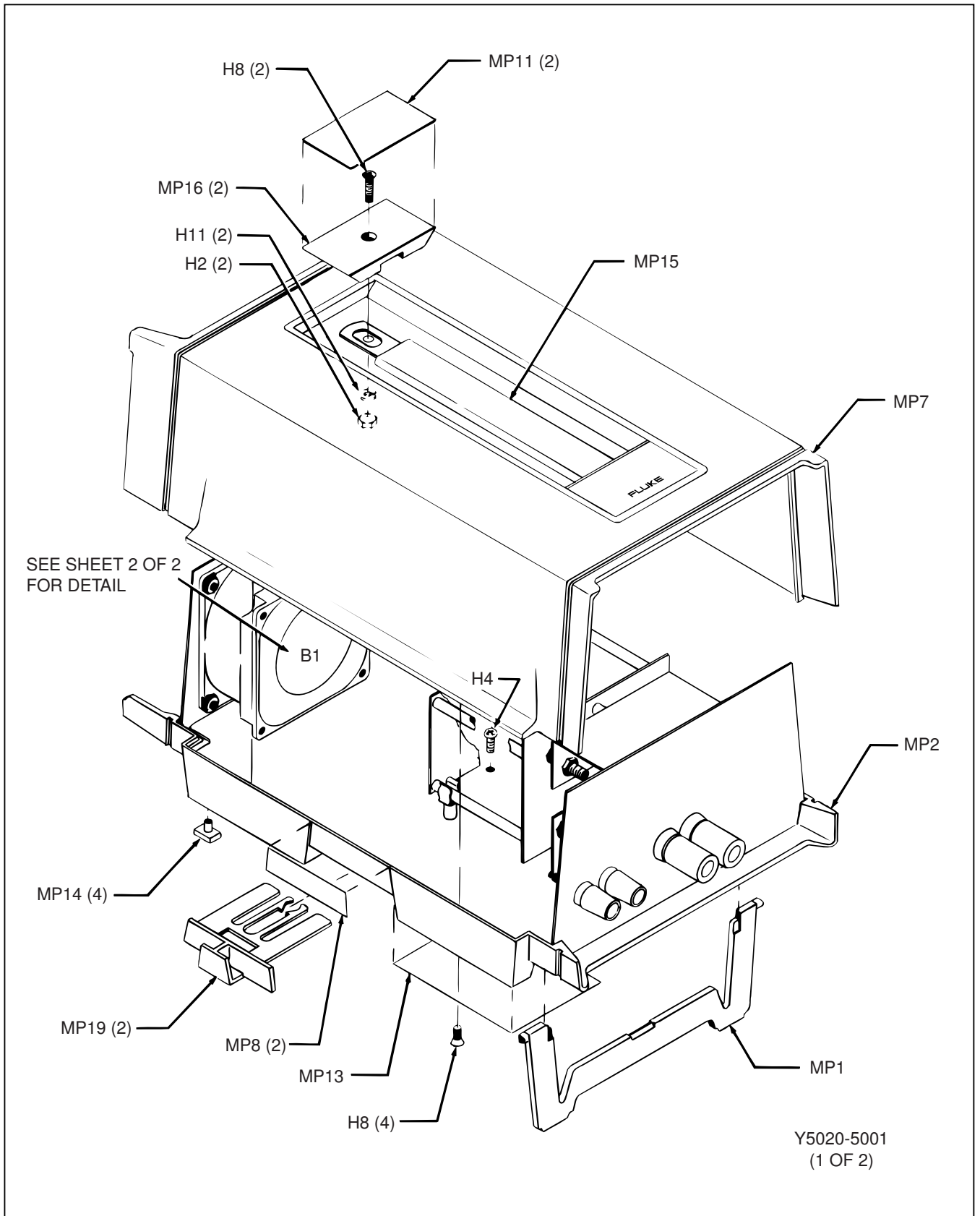

Figure 3. Y5020 Final Assembly



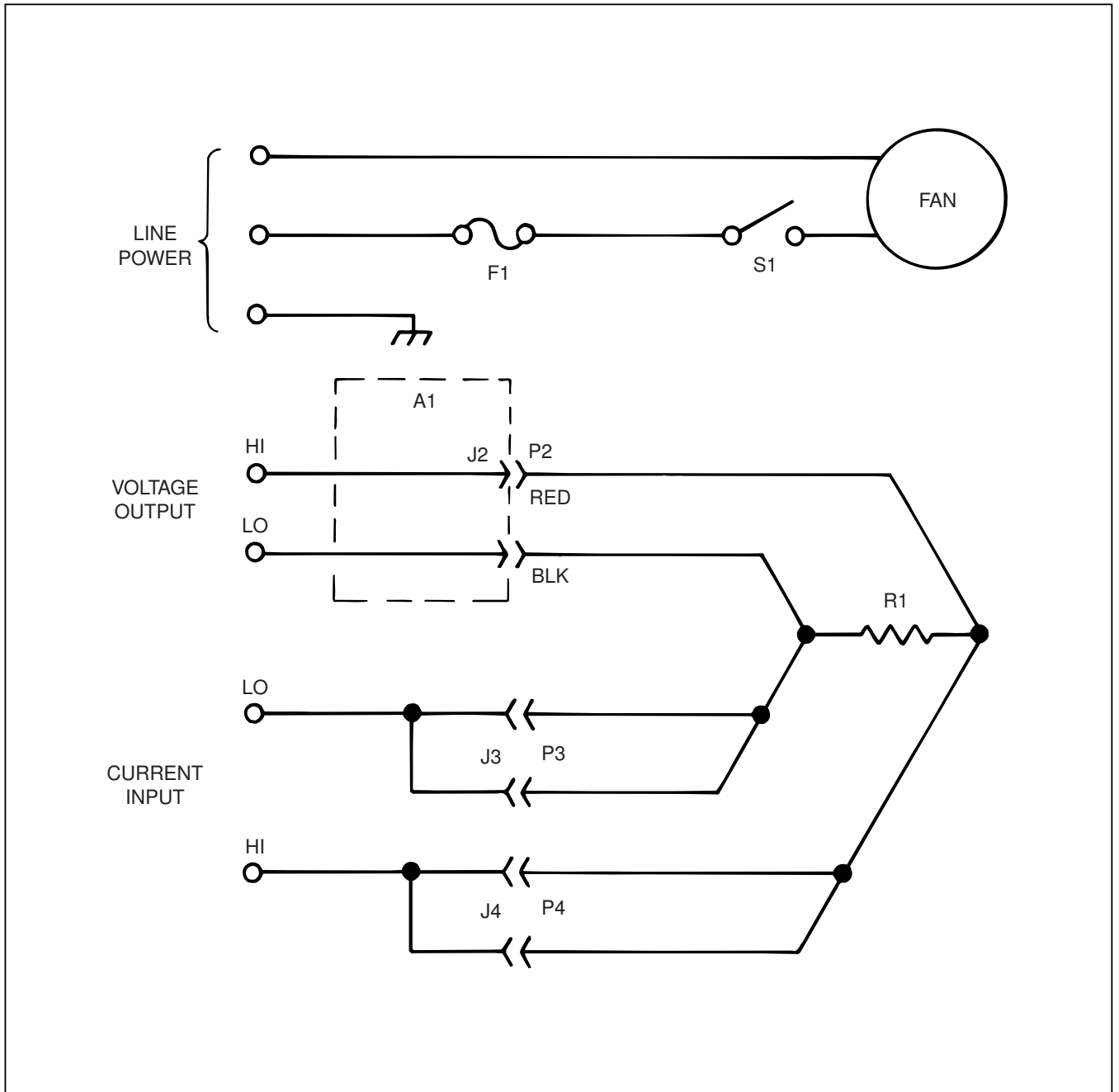

Figure 4. Y5020 Schematic Diagram

## Fluke Technical Service Centers — U.S. and Canada

United States		Canada	
<b>CALIFORNIA</b> <b>Burbank</b> Fluke Western Technical Center 2020 N. Lincoln St. Zip: 91504 Tel. (213) 849-4641	<b>ILLINOIS</b> <b>Rolling Meadows</b> Fluke Midwestern Tech. Ctr. 1400 Hicks Road Zip: 60008 Te. (312) 398-5800	<b>MASSACHUSETTS</b> <b>Waltham</b> Fluke N.E. Technical Center 244 Second Ave. Zip: 02154 Tel. (617) 890-1600	<b>ALBERTA</b> <b>Calgary</b> Fluke Canadian Technical Center 3829 - 12th St. N.E. Zip: T2E 6M5 Tel. (403) 276-9658
<b>Santa Clara</b> Fluke Western Technical Center 2359 De La Cruz Blvd. Zip: 95050 Tel. (408) 985-1200	<b>NORTH CAROLINA</b> <b>Greensboro</b> Fluke S.E. Technical Center 1310 Beaman Place Zip: 27408 Tel. (919) 273-1918	<b>NEW JERSEY</b> <b>Clifton</b> Fluke Eastern Technical Center 460 Colfax Ave. Zip: 07013 Tel. (201) 778-4040	<b>ONTARIO</b> <b>Mississauga</b> Fluke Canadian Technical Center 6503 Northam Drive Zip: L4V 1J5 Tel. (416) 678-1500
<b>COLORADO</b> <b>Denver</b> Fluke Southwestern Tech. Ctr. 1980 S. Quebec St. Unit 4 Zip: 80231 Tel. (303) 750-1228	<b>MINNESOTA</b> <b>Minneapolis</b> Fluke Midwestern Tech. Ctr. 10800 Lyndale Ave. So. Zip: 55420 Tel. (612) 884-4541	<b>WASHINGTON</b> <b>Mountlake Terrace</b> John Fluke Mfg. Co., Inc. 7001 - 220th Ave. S.W. Zip: 98043 Tel. (206) 774-2206	<b>QUEBEC</b> <b>Longueuil</b> Fluke Canadian Technical Center 1330 Marie Victorious Blvd. E. Zip: J4G 1A2 Tel. (514) 670-1212
<b>FLORIDA</b> <b>Orlando</b> Fluke S.E. Technical Center P.O. 6578 940 N. Fern Creek Ave. Zip: 32803 Tel. (305) 896-2296	<b>MARYLAND</b> <b>Kensington</b> Fluke Mideastern Tech. Ctr. 11501 Huff Court Zip: 20795 Tel. (301) 881-6155		

## Sales and Service Locations — International

Supplied and supported by Fluke (Nederland) B.V., P.O. Box 5053, Zevenheuvelenweg 53, Tilburg, Netherlands.			
<b>AUSTRIA</b> Walter Rekirisch Elektronische Gerate GmbH & Co. Vertrieb KG. Liechtensteinstrasse 97/6 A-1090 Vienna, Austria Tel. (222) 347646-0	<b>FRANCE</b> M.B. Electronique S.A. Rue Fourney ZAC de BUC, France Paris Tel. (01) 9563130	<b>ITALY</b> Sistrel S.p.A. Via Giuseppe Armellini No. 39 00143 Rome, Italy Tel. (06) 5915551	<b>SPAIN</b> Hispano Electronica S.A. Paligono Industrial Urtinsa Apartado de Correos 48 Alcorcon (Madrid), Spain Tel. 09-341-6194108
<b>BELGIUM</b> C.N. Rood S/A 37 Place de Jamblinne de Meux B-1040 Brussels, Belgium Tel. (02) 27352135	<b>GERMAN FEDERAL REPUBLIC</b> Fluke (Deutschland) GmbH 4-Dusseldorf Meineckestrasse 53 West Germany Tel. 211-450831	Sistrel S.p.A. Via Timavo 66 20099 Sesto S. Giovanni (Milan) Italy Tel. (02) 2476693	<b>SWEDEN</b> Teleinstrument AB P.O. Box 490 S-162 Vallingby-4 Sweden Tel. (08) 380370
<b>CYPRUS</b> Chris Radiovision Ltd. P.O. Box 1989 Nicosia, Cyprus Tel. 66121	Fluke (Deutschland) GmbH 8000 Munich 80 Vertriebsburo Bayern Rosenheimer Strasse 139 West Germany Tel. 089-404061	<b>NETHERLANDS</b> C.N. Rood, B.V. Cort van der Lindenstraat 11-13 Rijswijk ZH2280AA Netherlands Tel. (070) 996360	<b>SWITZERLAND</b> Traco Electronic AG Jenatschstrasse 1 8002 Zurich, Switzerland Tel. (01) 2010711
<b>DENMARK</b> Tage Olsen A/S Teglværsgade 37 DK-2100 Copenhagen 0, Denmark Tel. (01) 294800	<b>GREECE</b> Hellenic Scientific Representations Ltd. 11 Vrassida Street Athens 612, Greece Tel. (021) 7792320	<b>NORWAY</b> Morgenstjerne & Co. A/A Konghelligate 3 P.O. Box 6688, Rodelokka Oslo 5, Norway Tel. (02) 356110	<b>TURKEY</b> Erkman Elektronik Aletler Necatibey Cad 92/2 Karakoy/Istanbul Turkey Tel. 441546
<b>FINLAND</b> Oy Findip AB Teollisuustie 7 02700 Kauniainen Helsinki, Finland Tel. (080) 502255	<b>ISRAEL</b> R.D.T. Electronics Engineering Ltd. 46, Sokolov Street Ramat Hasharon 47235, Israel Tel. 482311	<b>PORTUGAL</b> Equipamentos De Laboratorio Ltda. P.O. Box 1100 Lisbon 1, Portugal Tel. (019) 976551	<b>UNITED KINGDOM</b> Fluke International Corp. Garnet Close Watford WD2 4TT, England Tel. (0923) 33066
Customers in the following countries:  Bulgaria, Czechoslovakia, Hungary, Poland, Romania, U.S.S.R. and Yugoslavia			
Contact: Amtest Associates Ltd., P.O. Box 55, Addlestone, Surrey, KT 15 1DU, England, Tel. (0932) 52121			