

M

NOTE

This manual documents the Model 732A and its assemblies at the revision levels shown in Appendix 7A. If your instrument contains assemblies with different revision letters, it will be necessary for you to either update or backdate this manual. Refer to the supplemental change/errata sheet for newer assemblies, or to the backdating sheet in Appendix 7A for older assemblies.

For the benefit and convenience of its customers, Fluke Corporation (Fluke) has reproduced this copy of a manual which is no longer in production. This manual has not been edited or updated since the revision date shown on the *lower left hand corner of the first page*. Fluke will not be liable for any claims, losses or damages of any kind incurred by any user arising from use of this manual.

732A

DC Reference Standard

Instruction Manual

P/N 645051
MAY 1983

©1983, John Fluke Mfg. Co., Inc., all rights reserved. Litho in U.S.A.



Table of Contents

SECTION	TITLE	PAGE
1	INTRODUCTION AND SPECIFICATIONS	1-1
	1-1. INTRODUCTION	1-1
	1-8. SPECIFICATIONS	1-1
2	OPERATION	2-1
	2-1. INTRODUCTION	2-1
	2-3. SHIPPING INFORMATION	2-1
	2-7. INSTALLATION	2-1
	2-9. FRONT AND REAR PANEL FEATURES	2-1
	2-11. OPERATING NOTES	2-1
	2-12. Introduction	2-1
	2-14. Input Power Requirements	2-1
	2-16. AC Line Voltage Selection	2-1
	2-18. Fuse Replacement	2-1
	2-20. Backup Operating Power	2-5
	2-22. Battery Charging	2-5
	2-25. IN CAL Indicator and RESET Terminal	2-5
	2-27. Portability	2-5
	2-29. Guarded Operation	2-5
	2-33. Oven Temperature Thermistor	2-6
	2-36. Minimizing Error Sources	2-6
	2-45. OPERATION	2-7
3	THEORY OF OPERATION	3-1
	3-1 INTRODUCTION	3-1
	3-3. OVERALL FUNCTIONAL DESCRIPTION	3-1
	3-8. CIRCUIT DESCRIPTION	3-1
	3-10. Power Supply (A3 and A4)	3-1
	3-14. Voltage Monitor	3-1
	3-17. Reference Circuit, A5	3-2
	3-20. Output Divider	3-2
	3-22. Oven Controller	3-2
	3-25. Battery Charger	3-2
4	MAINTENANCE	4-1
	4-1. INTRODUCTION	4-1
	4-5. SERVICE INFORMATION	4-1
	4-8. GENERAL MAINTENANCE	4-1

TABLE OF CONTENTS, *continued*

SECTION	TITLE	PAGE
4-9.	Access Procedure	4-1
4-19.	Oven Disassembly	4-6
4-21.	Front Panel Removal	4-6
4-23.	Cleaning	4-6
4-26.	Fuse Replacement	4-6
4-28.	AC Line Voltage Change	4-6
4-30.	ACCEPTANCE TEST	4-8
4-32.	CALIBRATION	4-8
4-35.	Null Verification	4-8
4-37.	Procedure A: Calibrate to Certified 732A	4-9
4-39.	Procedure B: Calibration to Standard Cells	4-10
4-41.	SERVICE/REPAIR PROCEDURES	4-14
4-42.	Introduction	4-14
4-44.	Battery Charger Adjustment Procedure	4-14
4-46.	TROUBLESHOOTING	4-14
4-47.	Introduction	4-14
4-49.	External Symptom Troubleshooting	4-16
4-51.	Internal Voltage Measurements	4-16
4-53.	Oven Repair	4-16
5	LIST OF REPLACEABLE PARTS	5-1
	TABLE OF CONTENTS	5-1
6	ACCESSORIES	6-1
	INTRODUCTION	6-1
6-3.	DUAL MOUNTING FASTENERS (M00-800-5237)	6-1
6-5.	HALF-WIDTH RACK MOUNT KIT (M07-203-601)	6-1
6-7.	FULL-WIDTH RACK MOUNT KIT (M07-200-603)	6-1
6-9.	LOW THERMAL EMF CABLE ASSEMBLY (5440A-7002)	6-1
6-11.	BATTERY PACK (732A-7001)	6-1
6-13.	TRANSIT CASE (732A-7002)	6-1
7	GENERAL INFORMATION	7-1
7A	MANUAL CHANGE INFORMATION	7A-1
8	SCHEMATIC DIAGRAMS	8-1
	TABLE OF CONTENTS	8-1
	INDEX	8-12

List of Tables

TABLE	TITLE	PAGE
1-1.	732A Accessories	1-1
1-2.	732A Specifications	1-2
2-1.	Front Panel Features	2-4
2-2.	Rear Panel Features	2-4
4-1.	Test Equipment Required	4-2
4-2.	External System Troubleshooting	4-17
4-3.	Internal Measurements	4-18

List of Illustrations

FIGURE	TITLE	PAGE
Frontispiece	732A DC Reference Standard	vi
1-1.	732A Outside Dimensions	1-4
2-1.	Front Panel Features	2-2
2-2.	Rear Panel Features	2-3
2-3.	Guard Connections	2-6
2-4.	732A/Precision Divider, Providing A Stable, Adjustable Source	2-8
3-1.	Functional Block Diagram	3-3
4-1.	Cover and Front Panel Screw Locations	4-3
4-2.	Rear Module Mounting Screw Locations	4-3
4-3.	Regulator PCB Assembly Removal	4-4
4-4.	Oven Assembly Removal	4-5
4-5.	AC Line Voltage Conversion on A3 Pre-Regulator PCB Assembly	4-7
4-6.	732A 10V Calibration	4-16
4-7.	Calibration of Point A to 10V Using 732A	4-10
4-8.	Calibration of 1.081V (and 1V) to 732A	4-10
4-9.	732A 10V Calibration Using Standard Cells	4-12
4-10.	732A Procedure 'B' 10V Calibration	4-13
4-11.	Calibration of 1.081V (and 1V) to 732A Procedure 'B'	4-13
4-12.	Battery Charger Test Points and Adjustments on A3 Pre-Regulator PCB Assembly	4-15

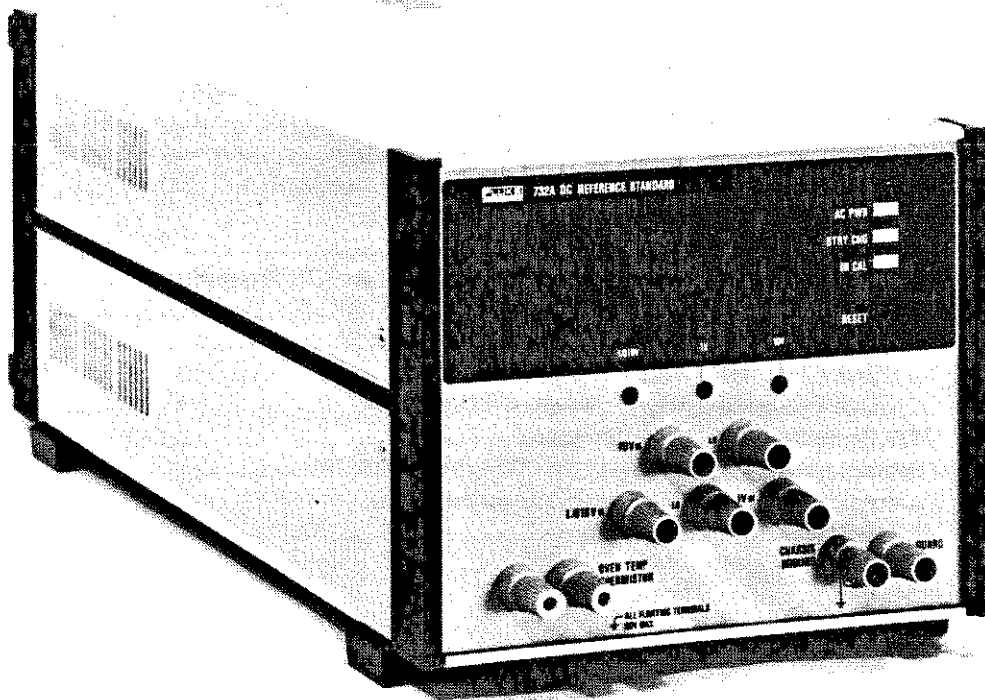

732A DC Reference Standard

Section 1

Introduction and Specifications

1-1. INTRODUCTION

1-2. The Fluke Model 732A is a highly stable, rugged, and transportable, solid state, dc voltage reference standard. The 732A has 10V, 1.018V and 1V outputs. These outputs are available on front panel binding posts. The calibration adjustments for the 10V, 1.018V and 1V outputs are accessible through the front panel. A non-conducting adjustment tool is supplied with the unit for this purpose.

1-3. All outputs of the 732A can be shorted indefinitely without damage. Recovery occurs in less than 2 minutes after the short is removed, with no loss of stability.

1-4. The stability and accuracy of the 732A allow direct substitution for saturated standard cells in many applications. The stability specification of 0.5 ppm for 30 days is achieved by enclosing the reference amplifier and output divider of the 732A in a high thermal gain oven. Full accuracy is attained over the specified ambient temperature range of $23 \pm 5^{\circ}\text{C}$ (64.4 to 82.4°F). Variations in oven temperature may be monitored externally via the OVEN TEMP THERMISTOR terminals on the front panel.

1-5. The 732A may be powered from ac line power, an internal rechargeable battery, or an external low voltage ac or dc source. The 732A is designed to be powered continuously, including during storage or shipment. The back-up battery will continue to operate the 732A for up to 12 hours. Either line or battery power may be removed without affecting the output. The battery is kept charged by an internal battery charger when operating from ac line power, or from the external low voltage ac or dc source.

1-6. Various front panel LEDs (indicators) provide a continuous indication of the operating status of the 732A. The AC PWR indicator illuminates in the presence of ac line power. The BTRY CHG indicator is on steadily for normal charging activity, and is off when the battery is charged. The IN CAL indicator monitors the input voltage to the Reference and Oven. Should this voltage fall below that needed to keep the 732A operational, the IN CAL indicator is latched off, indicating a loss of power and standardization. Once power is restored and standardization has been verified, the IN CAL indicator can be reset.

1-7. The 732A may be used on the bench or rack mounted. The 732A is a half-rack width instrument and occupies 4 standard 1.75 inch rack spaces. Accessories for the 732A are listed in Table 1-1 and described in more detail in Section 6 of this manual. There are no options available for the 732A.

1-8. SPECIFICATIONS

1-9. Table 1-2 lists the specifications for the 732A.

Table 1-1. Accessories

MODEL NUMBER	DESCRIPTION
M00-800-523	Dual Mounting Fastener
M07-203-601	Half Width Rack Mount Kit
M07-200-601	Full Width Rack Mount Kit
5440A-7002	Low Thermal EMF Cable Assembly
732A-7001	Battery Pack
732A-7002	Transit Case
732A-7003	Battery Charger

Table 1-2. 732A Specifications

OUTPUT VOLTAGE 10 volts, 1.018 volts, or 1 volt

TRANSFER UNCERTAINTY @18°C to 28°C

Output Voltage	Time Interval			
	30 Days	90 Days	6 Months	1 Year
10V	0.5 ppm	1.5 ppm	3.0 ppm	6.0 ppm
1.018V	1.5 ppm	4.0 ppm	8.0 ppm	12.0 ppm
1V	1.5 ppm	4.0 ppm	8.0 ppm	12.0 ppm

These specifications assume the unit has been continuously powered up with either ac or battery or both. The specifications include effects due to line regulation.

TEMPERATURE COEFFICIENT OF OUTPUT

Range	Temperature Coefficient (ppm/°C)	
	0°C to 18°C	28°C to 40°C
10V	±0.05	±0.05
1.018V	±1.0	±1.0
1V	±1.0	±1.0

OUTPUT ADJUSTMENT AND RESOLUTION

Output	Adj. Range	Adj. Resolution
10V	±50 μ V	<0.05 ppm
1.018V	±50 μ V	<0.25 ppm
1.0V	±5 μ V	<0.10 ppm

OUTPUT IMPEDANCE

10V ≤5 milliohms
1.018V, 1V ≈1 kilohm

OUTPUT CURRENT

10V 12 mA maximum
1.018V, 1V Current limited by 1k Ω source impedance

OUTPUT PROTECTION The output may be shorted indefinitely without damage to the instrument. The instrument is protected against high voltage up to 1000V provided that the net current into the 732A does not exceed 30 mA.

OUTPUT NOISE ≤1 μ V RMS at 10V output, 0.1-10 Hz.

LOAD REGULATION AT

0.12 mA OUTPUT CURRENT ≤6.0 ppm

LINE REGULATION ≤0.05 ppm of output for full ±10% power line variation.

LINE POWER REQUIREMENTS

Nominal Setting	Voltage Limits	Fuse
100V	90-110V	0.375A/250V SLO-BLO
120V	108-132V	0.375A/250V SLO-BLO
220V	198-242V	0.250A/250V SLO-BLO
240V	216-264V	0.250A/250V SLO-BLO

Table 1-2. 732A Specifications (cont)

AUXILIARY LOW VOLTAGE POWER REQUIREMENTS	24-40V dc or 24-30V ac 50-400 Hz
INTERNAL BATTERIES	24V gelled-electrolyte lead-acid
TYPICAL BATTERY LIFE	12 hours at 23°C
PROTECTION CLASS	Class 1 as defined in IEC 348.
SIZE (HxWxD)	19.1 cm x 22.1 cm x 60.3 cm 7.5 in. x 8.5 in. x 23.7 in. (see Figure 1-1)
WEIGHT	12.3 kg (27 lbs.)
COMPLIANCE WITH EXTERNAL STANDARDS	ANSI C39.5 Draft #8 IEC 348 2nd edition, 1978 CSA bulletin 556B, 17 Sep 1973 VDE 0411-1973 UL 1244
OPERATING TEMPERATURE	0°C to 40°C
ALTITUDE	
Non-operating	0-12,200 meters, (40,000 feet)
Operating	0-3,050 meters, (10,000 feet)

TEMPERATURE AND HUMIDITY

Condition	Temperature (°C)	% Relative Humidity (Non-condensing)
Non-operating	-40 to +50 0 to 50	Not Controlled 95 ±5%
Operating	0 to 30 30 to 40	95 ±5% 7 ±5%

VIBRATION

Frequency	G Force Frequency	Double Amplitude
5-55 Hz	2 @ 55 Hz	0.013 inch

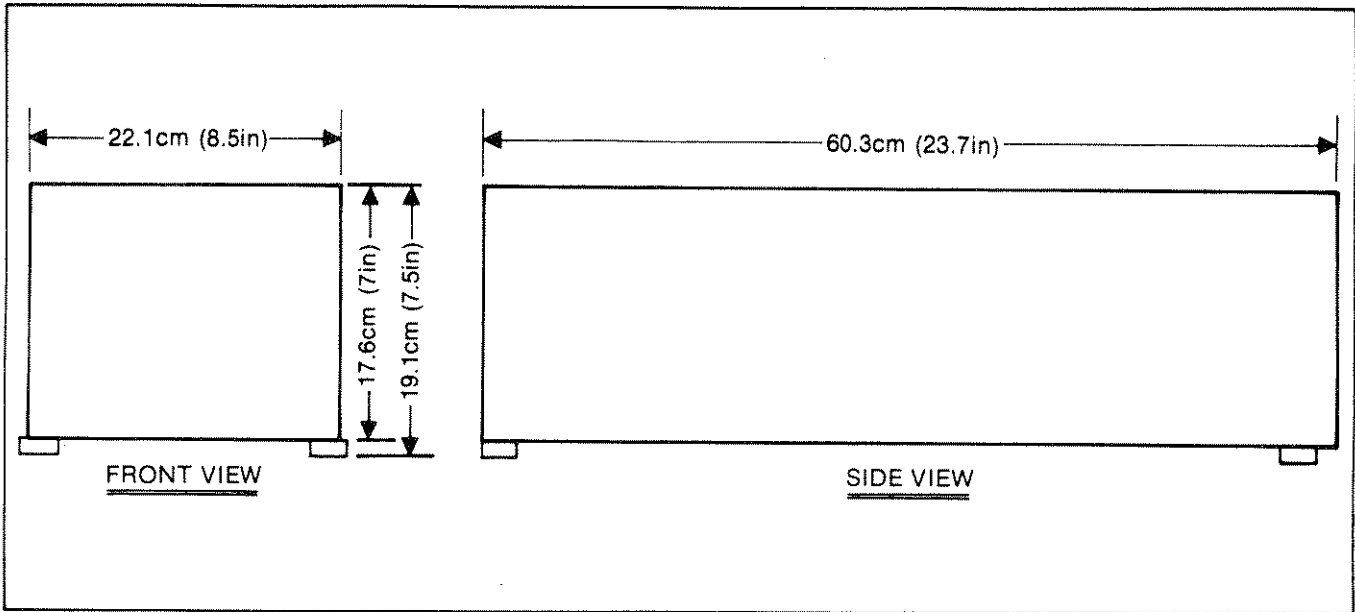

Figure 1-1. Outside Dimensions



static awareness



A Message From
John Fluke Mfg. Co., Inc.

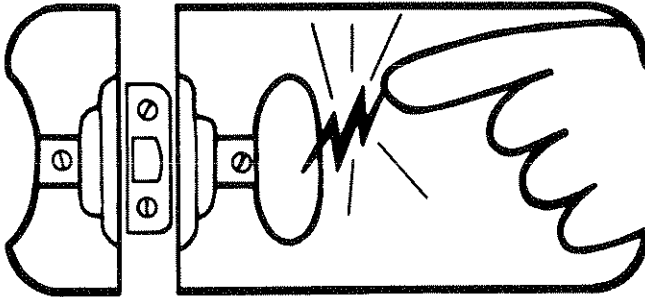

Some semiconductors and custom IC's can be damaged by electrostatic discharge during handling. This notice explains how you can minimize the chances of destroying such devices by:

1. Knowing that there is a problem.
2. Learning the guidelines for handling them.
3. Using the procedures, and packaging and bench techniques that are recommended.

The Static Sensitive (S.S.) devices are identified in the Fluke technical manual parts list with the symbol



The following practices should be followed to minimize damage to S.S. devices.

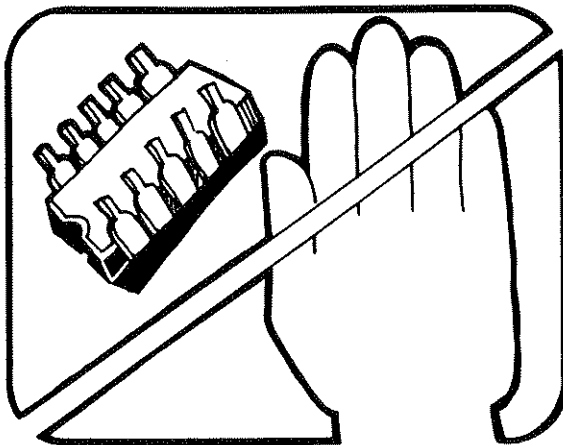

1. MINIMIZE HANDLING

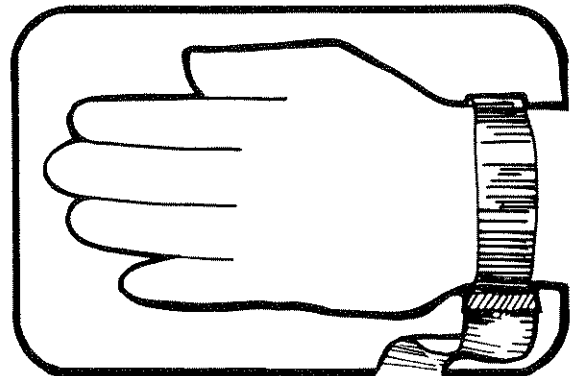

3. DISCHARGE PERSONAL STATIC BEFORE HANDLING DEVICES

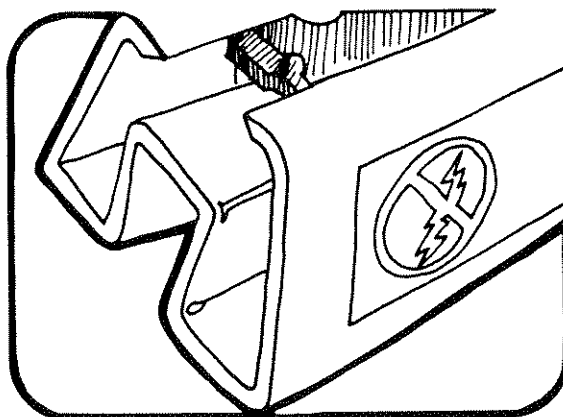

2. KEEP PARTS IN ORIGINAL CONTAINERS UNTIL READY FOR USE.

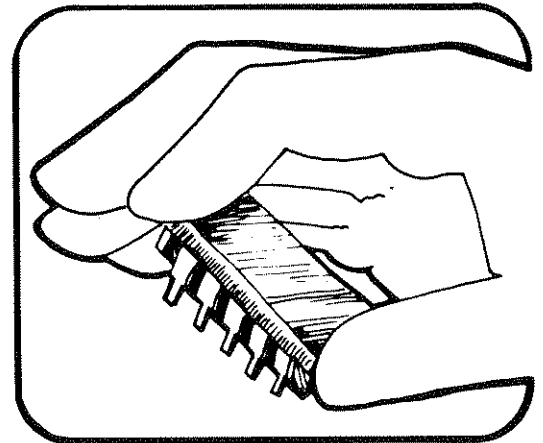

4. HANDLE S.S. DEVICES BY THE BODY

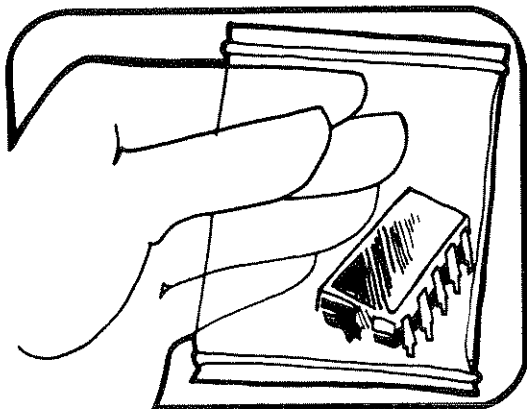

5. USE ANTI-STATIC CONTAINERS FOR HANDLING AND TRANSPORT

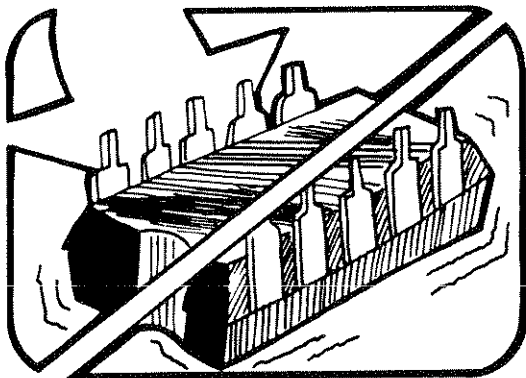

6. DO NOT SLIDE S.S. DEVICES OVER ANY SURFACE

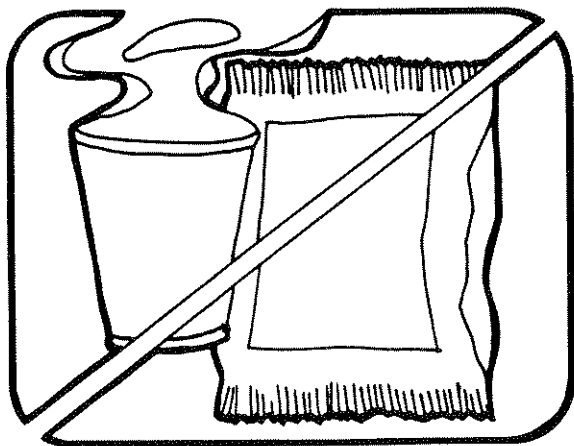

7. AVOID PLASTIC, VINYL AND STYROFOAM® IN WORK AREA

PORTIONS REPRINTED
WITH PERMISSION FROM TEKTRONIX, INC.
AND GENERAL DYNAMICS, POMONA DIV.

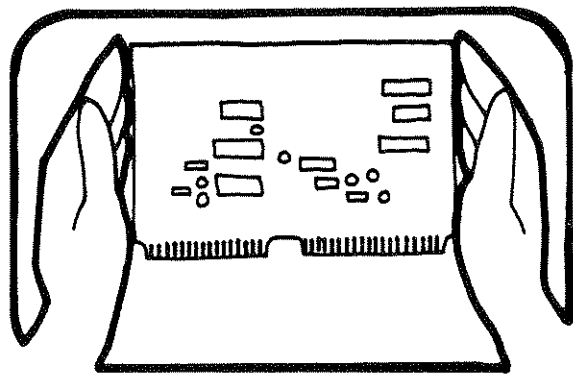

8. WHEN REMOVING PLUG-IN ASSEMBLIES, HANDLE ONLY BY NON-CONDUCTIVE EDGES AND NEVER TOUCH OPEN EDGE CONNECTOR EXCEPT AT STATIC-FREE WORK STATION. PLACING SHORTING STRIPS ON EDGE CONNECTOR USUALLY PROVIDES COMPLETE PROTECTION TO INSTALLED SS DEVICES.

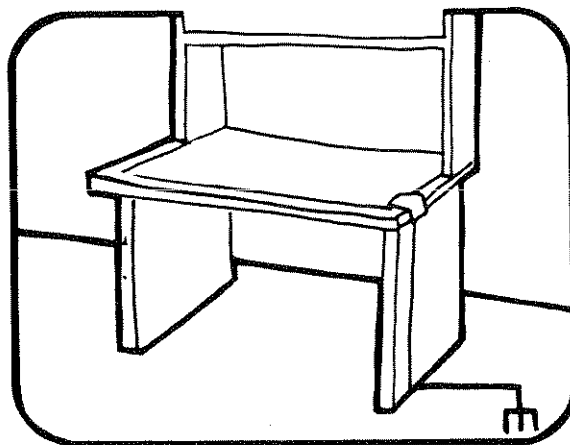

9. HANDLE S.S. DEVICES ONLY AT A STATIC-FREE WORK STATION
10. ONLY ANTI-STATIC TYPE SOLDER-SUCKERS SHOULD BE USED.
11. ONLY GROUNDED TIP SOLDERING IRONS SHOULD BE USED.

Anti-static bags, for storing S.S. devices or pcbs with these devices on them, can be ordered from the John Fluke Mfg. Co., Inc.. See section 5 in any Fluke technical manual for ordering instructions. Use the following part numbers when ordering these special bags.

John Fluke Part No.	Description
680892	5" x 8" Bag
680934	8" x 10" Bag
680942	8" x 12" Bag
680983	12" x 16" Bag
681023	18" x 18" Bag

Pink Poly Sheet	Wrist Strap
30" x 60" x 60 Mil	P/N TL6-60
P/N RC-AS-1200	\$7.00
\$20.00	

J0089C-07U8412/SE EN Litho in U.S.A.

Section 2 Operation

2-1. INTRODUCTION

2-2. The information in this section describes the installation and operation of the Model 732A. It is recommended that the contents of this section be read and understood before any attempt is made to operate the instrument. Should any difficulties arise during operation, contact your nearest John Fluke Sales Representative, or the factory. Our mailing address is: John Fluke Mfg. Co., Inc.; P.O. Box C9090; Everett, WA 98206 (206) 347-6100

2-3. SHIPPING INFORMATION

2-4. The 732A is packaged and shipped in a foam-packed container. Upon receipt of the instrument, a thorough physical and electrical inspection should be made to reveal any possible shipping damage. Special instructions for inspection and claims are included on the shipping carton.

2-5. If reshipment of the instrument is necessary, the original container or equivalent should be used.

2-6. If the instrument is to be shipped with battery power on, use the Transit Case accessory described in Section 6. Alternatively, 24V to 40V dc or 24V to 30V ac may be applied, via the rear panel connectors, to supply power during shipment.

2-7. INSTALLATION

2-8. The 732A is designed for convenient operation as either a bench or a rack-mount instrument. Rack mounting accessories available for use with the 732A are described in Section 6.

2-9. FRONT AND REAR PANEL FEATURES

2-10. The Front and Rear panels are shown in Figures 2-1 and 2-2. The various controls and connections are listed and explained in Tables 2-1 and 2-2.

2-11. OPERATING NOTES

2-12. Introduction

2-13. The following paragraphs describe various conditions that should be considered before operating the 732A. If the 732A is brand new, set the rear panel BATTERY OPR switch to ON and perform the acceptance test described in Section 4 of this manual.

2-14. Input Power Requirements

2-15. The 732A is designed to be powered continuously (including storage or shipment) to maintain standardization. Normally, power is continuously applied, either to the ac line input connector or to the low voltage ac or dc input connectors. The ac line power requirements are: 100V, 120V, 220V or 240V ac $\pm 10\%$, at 50 or 60 Hz. Low voltage, 24-40V dc or 24-30V ac, 50-400 Hz may be connected to supply instrument power and charge the internal backup battery through connectors on the rear panel. The internal, rechargeable gell-cell (sealed, gelled electrolyte lead-acid) battery provides approximately 12 hours of continuous operation when ac power is not available.

2-16. AC Line Voltage Selection

2-17. The Line Voltage Selector switches are located inside the instrument. Their setting is marked on the rear panel (See Figure 2-2). If the marked setting does not agree with the locally available ac power, the settings of the internal Line Voltage Selector switches must be changed. Refer this and all servicing to qualified personnel. The procedure is described in Section 4.

2-18. Fuse Replacement

2-19. The ac line fuse is located on the rear panel of the instrument. If the fuse requires replacement, replace it with one appropriate for the ac line voltage indicated on the rear panel. For ac line voltages from 100V to 120V use a 3/8A Slow-Blow fuse. For ac line voltages from 220V to 240V use a 1/4A Slow-Blow fuse.

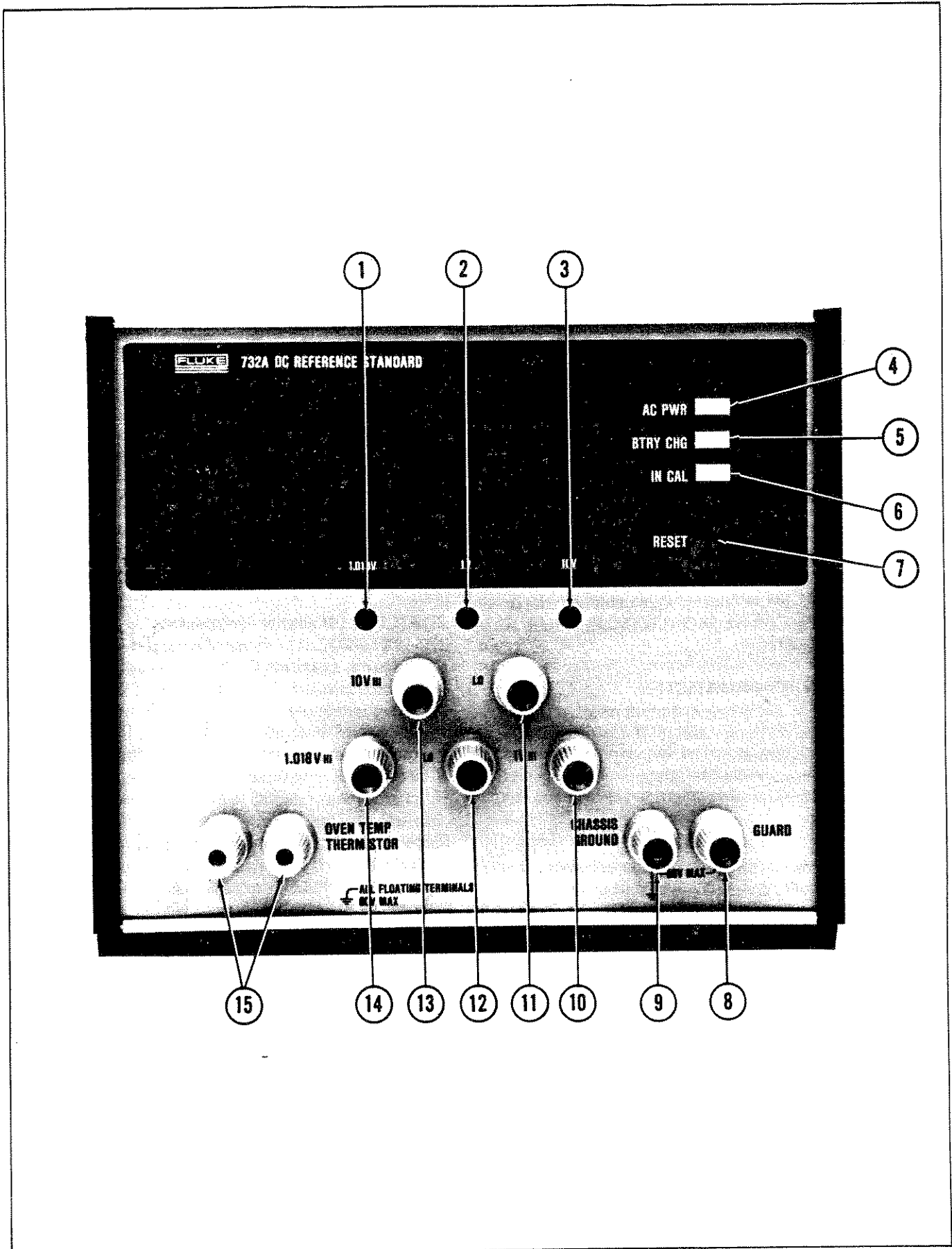

Figure 2-1. Front Panel Features

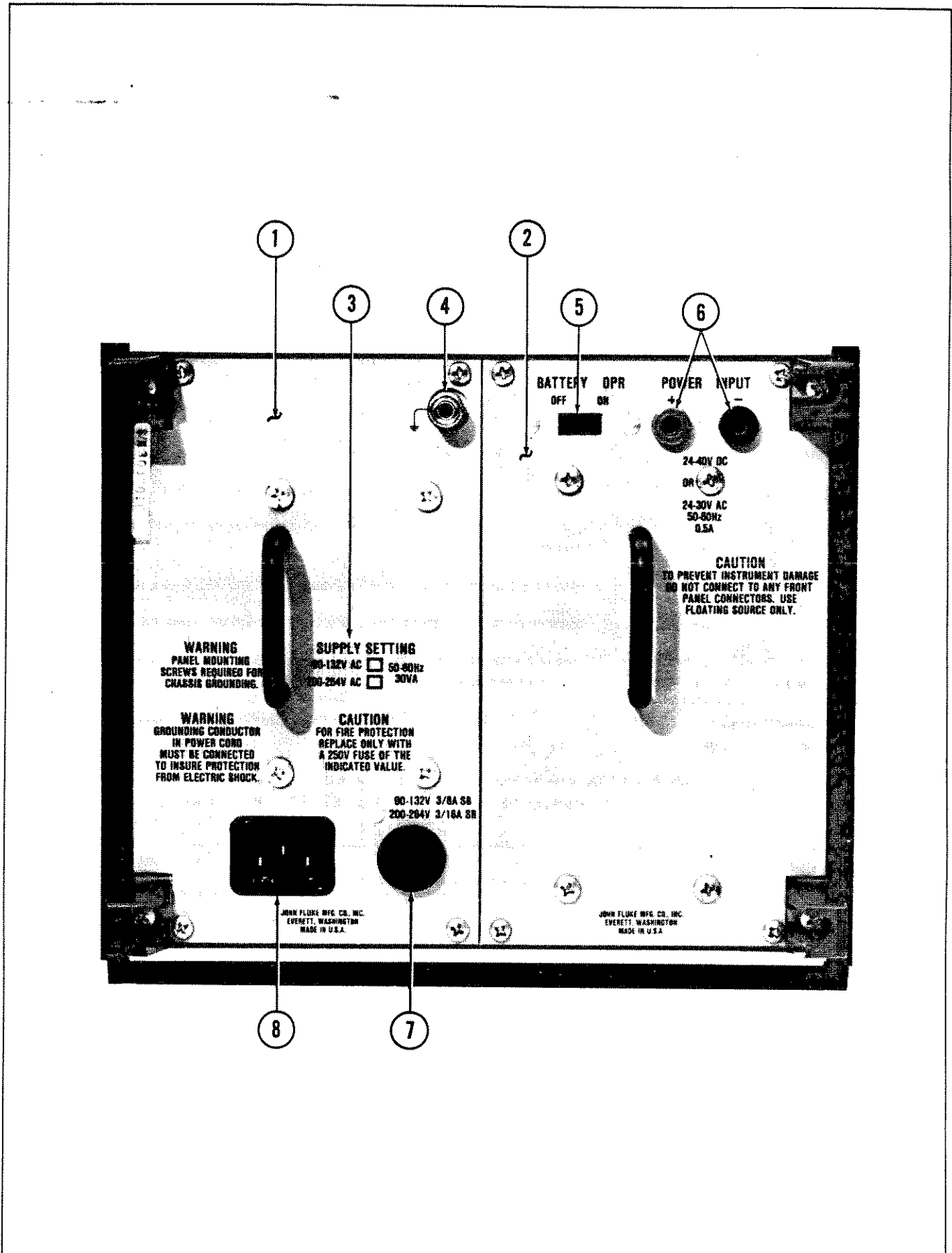

Figure 2-2. Rear Panel Features

Table 2-1. 732A Front Panel Controls and Adjustments

ITEM	FEATURE NAME	DESCRIPTION
1	1.018V Adjustment*	Calibration tool adjustment. $\pm 50 \mu\text{V}$ adjust for 1.018V output.
2	1V Adjustment*	Calibration tool adjustment. $\pm 5 \mu\text{V}$ adjust for 1V output.
3	10V Adjustment*	Calibration tool adjustment. $\pm 50 \mu\text{V}$ adjust for 10V output.
4	AC PWR Indicator	LED that indicates the presence of ac power when illuminated.
5	BTRY CHG Indicator	LED that indicates battery charger operation when illuminated.
6	IN CAL Indicator**	LED that indicates out-of-calibration condition when not illuminated.
7	RESET**	Terminal behind front panel to reset the IN CAL indicator to ON condition.
8	GUARD Terminal	Binding post that connects to internal Guard circuit. Normally connected to OUTPUT LO at some point in the measurement system. 60V is the maximum differential allowed between GUARD and CHASSIS GROUND.
9	CHASSIS GROUND Terminal	Binding post connected to the chassis of the 732A.
10	1V HI Terminal	Binding post on which the 1V output of 732A is available.
11	LO Terminal	Binding post which provides common connection for the 10V output.
12	LO Terminal	Binding post which provides common connection for the 1V and 1.018V outputs.
13	10V HI Terminal	Binding post on which the 10V output of the 732A is available.
14	1.018V HI Terminal	Binding post on which the 1.018V output of the 732A is available.
15	OVEN TEMP THERMISTOR terminals	3/4-inch spaced dual binding posts. Floating thermistor for monitoring oven temperature.

*The 10V adjustment affects both the 1.018V and 1V outputs. This adjustment should be made first when calibrating the 732A. See Section 4.

**The IN CAL indicator detects an out-of-range condition within the power supply of the 732A. If not illuminated, the 732A is not operating at its specified accuracy. Use the RESET terminal to restore the IN CAL indicator after re-calibration. See Section 4.

Table 2-2. 732A Rear Panel Features and Controls

ITEM NO.	FEATURE NAME	DESCRIPTION
1	AC Module	Rear panel module containing the A3, Pre-Regulator PCB Assembly.
2	Battery Module	Rear panel module containing the A6A1, Battery PCB Assembly.
3	SUPPLY SETTING (Ac power requirements)	Specifies the correct ac line voltage required to operate the instrument.
4	\perp chassis terminal	Binding post that provides a direct chassis connection.
5	BATTERY OPR switch	Slide switch that sets instrument back-up battery supply, on or off.
6	POWER INPUT jacks	Dual 3/4-inch spaced banana jacks for connecting an external power source (24-40V dc or 24-30V ac, 50-440 Hz). The internal back-up battery voltage may also be measured at these jacks.

Table 2-2. Rear Panel Features (cont)

ITEM	FEATURE NAME	DESCRIPTION
7	Fuse holder	AC line fuse holder.
8	Power connector	IEC 3-wire receptacle, for ac line power connection. See item 3 for specified ac line voltage.

2-20. Backup Operating Power

2-21. If ac line power fails or drops more than 30% below the nominal value, the internal battery automatically maintains operation. Set the rear panel BATTERY OPR switch to on to enable the internal battery. When line power fails, the AC PWR indicator goes out, but the IN CAL indicator remains on. The unit will continue to operate normally, until the battery discharges. When the battery is discharged, the IN CAL indicator will go out. When ac power is restored, the BTRY CHG indicator illuminates, until the battery is fully charged, The IN CAL indicator will not illuminate. This indicates that the standardization of the instrument must be reverified before the 732A is used. The battery voltage may be measured at the POWER INPUT jacks with a high impedance multimeter, such as Multimeter A, Table 4-1.

2-22. Battery Charging

CAUTION

PERMANENT BATTERY DAMAGE WILL RESULT IF THE BATTERY IS ALLOWED TO DISCHARGE BELOW 19 VOLTS. THE DEGREE OF DAMAGE IS A FUNCTION OF THE DEPTH OF OVER-DISCHARGE AND THE BATTERY TEMPERATURE.

2-23. Under normal operation, battery life should exceed 5 years. For best battery life, minimize the number of charge/discharge cycles and avoid deep (<19V) discharge.

2-24. If the battery is fully discharged, 24 hours is required to fully recharge the battery when operating the 732A from ac line power. If the battery is not fully discharged, the charging time will be less, but always in excess of the discharge time. When the battery is charging, the BTRY CHRG indicator glows to indicate charging activity and turns off when the battery is fully charged.

2-25. IN CAL Indicator and RESET Terminal

2-26. If the IN CAL indicator does not illuminate (ac power lost, battery dead or turned off), the output of the 732A may not meet the specifications listed in Section 1. The RESET terminal, located behind the front panel, is used to restore the IN CAL indicator to the ON condition.

See Section 4 for the reset procedures. Before resetting the indicator, apply power (ac line or low voltage external ac or dc), allow a stabilization period of 24 hours, then check the 732A to insure that the various outputs are within specification.

2-27. Portability

2-28. The 732A is portable and operational at ambient temperatures between 0 and 40°C (32 to 104°F). Normal handling and transportation will not alter accuracy or stability if power is maintained by the internal battery or through the external power connections. The instrument may be used immediately after transportation, provided that the IN CAL indicator is illuminated and that the instrument has not been exposed to ambient temperatures beyond the normal operating range ($23 \pm 5^\circ\text{C}$).

2-29. Guarded Operation

WARNING

LETHAL VOLTAGES MAY BE PRESENT WHEN OPERATING THE 732A WITH THE GUARD AND CHASSIS GROUND CONNECTIONS SEPARATED. A MAXIMUM POTENTIAL DIFFERENCE OF 60V RMS MAY APPEAR BETWEEN ANY COMBINATION OF THE GUARD TERMINAL, CHASSIS GROUND, REFERENCE STANDARD OUTPUT, OR OVEN TEMPERATURE THERMISTOR OUTPUT. IF THIS LIMITATION IS EXCEEDED, DAMAGE TO THE INSTRUMENT MAY RESULT.

2-30. The 732A is equipped with a guard that isolates the internal circuitry from chassis and earth ground. A GUARD terminal is provided on the front panel. When properly used the guard can greatly reduce errors caused by common mode voltages. In general, guarded operation will be necessary under the following conditions:

1. When a potential exists between equipment power line grounds.
2. When long connection leads are used to connect a high impedance load.
3. When operating the instrument in the presence of high level radiated noise.

2-31. A potential difference may exist between the power line grounds of the 732A and an instrument to which it is connected. This potential difference can cause circulating ground currents which cause errors in the output voltage.

2-32. To prevent these errors the 732A GUARD terminal should be connected to the load in such a manner as to provide a separate path for the circulating currents. Connect the GUARD terminal to the grounded side of the load, at the load. Figure 2-3 illustrates the correct GUARD terminal connection and the rerouted ground currents. The circulating current path may also be broken by operating the 732A on battery power as described later in this section.

2-33. Oven Temperature Thermistor

2-34. A Thermistor, mounted inside the Oven Assembly senses changes in the internal oven temperature. Use the Oven Temperature Thermistor in conjunction with an external ohmmeter to monitor the temperature stability of the oven vs time. The thermistor terminals are on to the front panel of the 732A. Both leads of the thermistor are isolated from all parts of the 732A circuitry. A maximum potential difference of 60V is allowed between either of

the thermistor terminals and any other front panel terminal (Guard, Ground, Reference Standard Outputs).

2-35. The nominal value of the Oven Temperature Thermistor is between 3 k Ω and 4 k Ω at the normal oven operating temperature. The thermistor has a temperature coefficient of 3.8%/°C. The actual operating value is shipped with the instrument.

2-36. Minimizing Error Sources

2-37. The inherent accuracy and stability of the 732A may be easily degraded if the effects of thermal emf, lead resistance and other factors are not considered and minimized.

2-38. THERMAL ERRORS

2-39. When parts of a circuit operate at different temperatures, thermal voltages will normally be present at the equipment connections. These thermal voltages can exceed 10 μ V. Use the following techniques to minimize thermal errors:

1. Use the Fluke 5440-7002 Low Thermal EMF Interconnecting Cable Assembly . See Section 6, Accessories.

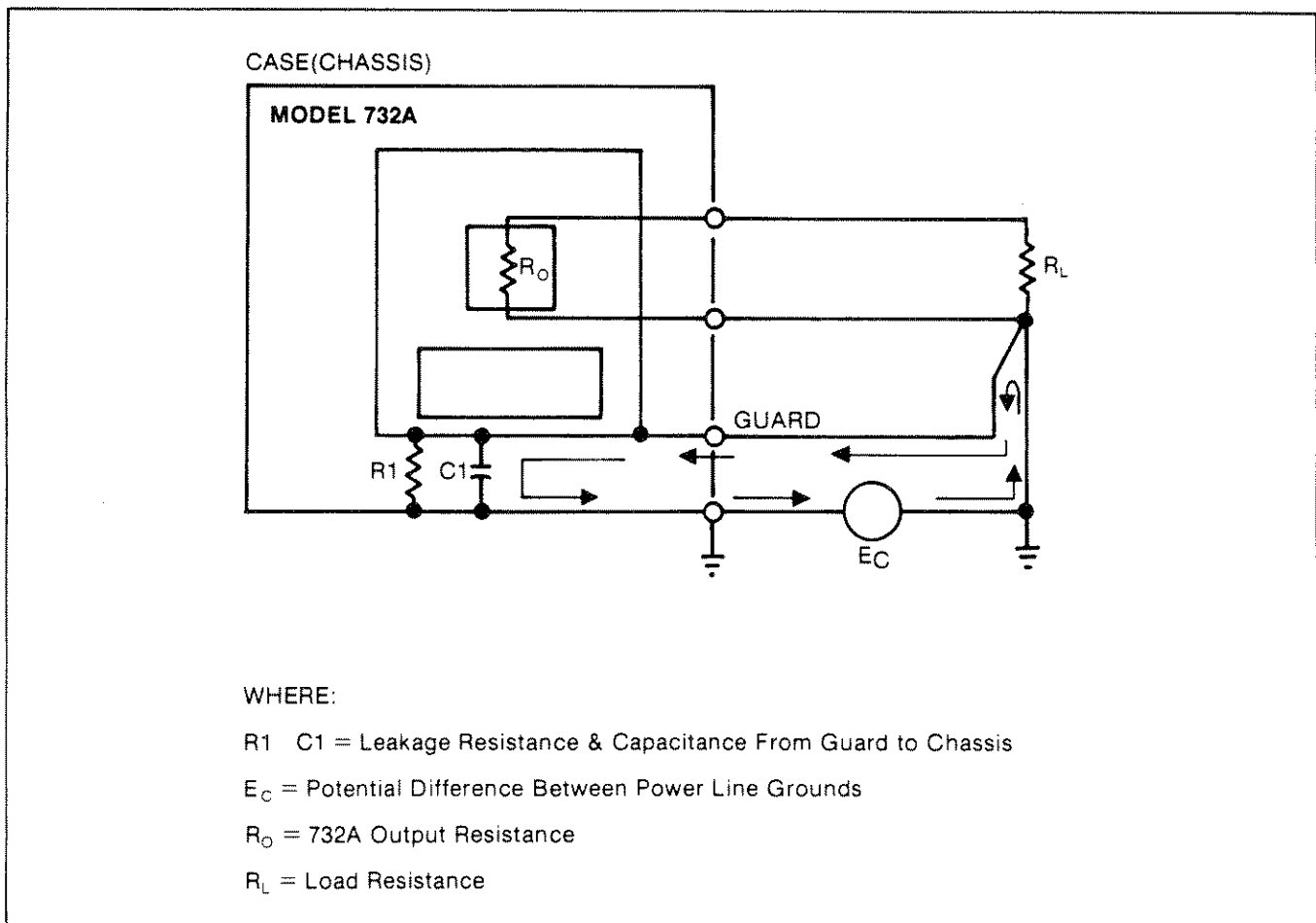

Figure 2-3. Guard Connection

2. Use #24 AWG or larger, bare copper, Teflon insulated connecting wires. It is preferable to use shielded, twisted pair cable. Avoid splices.

3. Avoid the use of ordinary, nickel-plated, banana plugs for equipment interconnections. Use of low thermal emf spade lugs is recommended. Crimp the lug onto the wire before soldering. Loosen the top of the binding post, insert the lug and tighten the binding post on the lug.

2-40. OTHER ERROR SOURCES

2-41. The effects of the finite (though very low) output impedance of the 732A, the lead wire resistance and the loading caused by the reference divider can not be ignored. Use the following procedure to minimize the effects of test lead resistance and output loading:

1. Connect the equipment as shown in Figure 2-4.
2. Calibrate the 732A/Reference Divider combination at the divider input terminals.
3. When calibration is complete, treat the 732A and the Reference Divider as a system.
4. Do not disconnect the Reference Divider at any time, even if it is not required in a given procedure. Since the 732A/Reference Divider system was calibrated at the divider input terminals, disconnecting it will change the loading on the 732A, and affect the calibration.

2-42. LONG TERM STABILITY

2-43. The user can determine the long term stability of the 732A by tracking (recording) the output voltage before and after each calibration. Over a period of time, the tracked data should allow the user to compensate for systematic errors in accuracy and precision. (Accuracy is defined as the error between the 732A output and a known standard. Precision is defined as the measure of

repeatability of the 732A output voltage in a statistical sample).

2-44. When the user has compensated for all systematic errors, only random errors should remain. The uncertainty of measurements will then be a function of the random errors and user errors.

2-45. OPERATION

2-46. Use the following procedure to prepare the 732A for initial operation.

1. Check the rear panel for ac power requirements and connect the 732A power cord to an appropriate power source.
2. Set the BATTERY OPR switch to ON.
3. Verify that the AC PWR indicator is illuminated. The BTRY CHG indicator is also illuminated if the batteries are not fully charged.
4. Allow the unit to stabilize for a period of 24 hours if either of the following apply:
 - a. The IN CAL indicator is not illuminated.
 - b. If the instrument has been stored in or exposed to ambient temperatures in excess of the normal operating range ($23 \pm 5^{\circ}\text{C}$). Allow the unit to stabilize for 24 hours.
5. Insure that the 732A is calibrated according to the procedures described in Section 4.
6. The instrument is now ready for use.
7. If the IN CAL indicator goes out, the output of the 732A is not standardized. Notify the Calibration department or person(s) responsible for maintaining the 732A. Refer to Section 4.

NOTE

Use low thermal emf connections between the 732A and the precision divider input terminals.

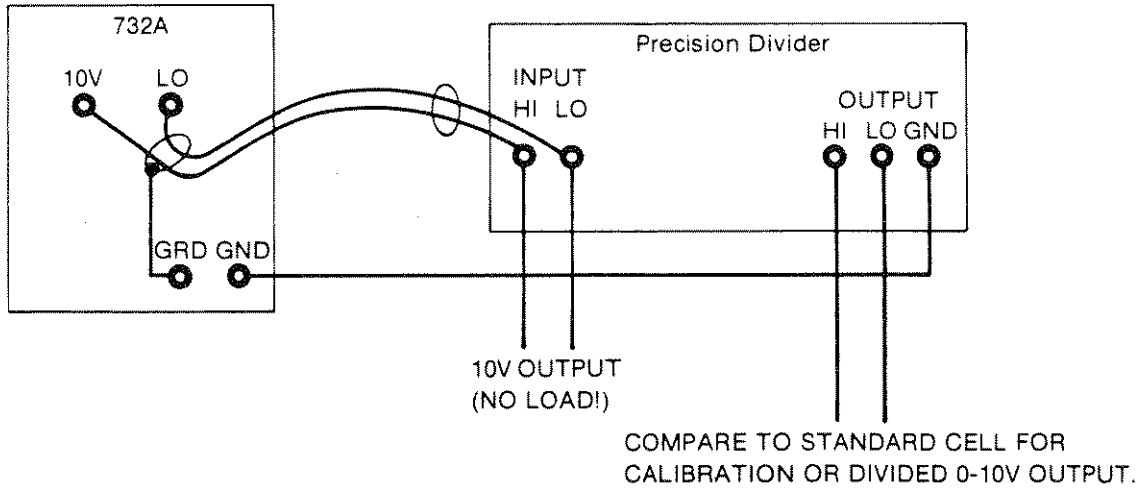

Figure 2-4. 732A/Precision Divider, Providing a Stable, Adjustable Source

Section 3

Theory of Operation

3-1. INTRODUCTION

3-2. The information in this section describes the theory of operation of the 732A. It contains an overall functional description followed by a circuit description of the 732A. Both descriptions are supported by a block diagram (Figure 3-1). Component level descriptions contained in the circuit analysis are referenced to the detailed schematics in Section 8 of this manual.

3-3. OVERALL FUNCTIONAL DESCRIPTION

3-4. The 732A dc Voltage Reference Standard is a highly stable 10V, 12 mA power supply. Refer to Figure 3-1. AC line input power is full wave rectified and fed to a two stage voltage regulator. The first stage, or Pre-regulator converts the raw dc to 32V dc. The second stage, or Regulator converts this voltage to 18.5V dc which powers the Oven Controller and the Reference.

3-5. The Voltage Monitor disables the Oven Controller and latches the IN CAL indicator off when the output of the Regulator is insufficient for proper operation. The RESET terminal is used to restore the IN CAL indicator to the ON condition after standardization of the instrument has been performed.

3-6. If ac line power fails or is not available, an internal, sealed, lead-acid battery maintains operating power to the 732A. When ac power is available, a battery charger charges the battery. This is indicated by the BTRY CHG indicator.

3-7. When ac power is not available, the battery may be charged by an external ac or dc source connected at the rear panel POWER INPUT connectors. The external source can also supply operating power for the instrument. The battery voltage can also be measured at the rear panel connectors.

3-8. CIRCUIT DESCRIPTION

3-9. The information in this section describes the circuitry of the 732A to the functional block diagram level. Refer to the detailed schematics in Section 8.

3-10. Power Supplies (A3 and A4)

3-11. The 732A has two cascaded regulators. The Pre-regulator (A3Q1) is a simple emitter follower regulator that clamps the full wave rectified power from the bridge rectifier to approximately 32V dc.

3-12. The Regulator (located on A4) supplies operating voltages to all of the circuitry in the 732A except the battery charger. During battery operation, the battery drives the Regulator input.

3-13. The Regulator (Q1, Q2, Q3, Q4) is a conventional series pass transistor error-amplifier design that regulates the 32V to 18.6V dc.

3-14. Voltage Monitor

3-15. The Voltage Monitor circuit (Q5, Q6, Q7, Q8) checks the regulator output and disables the instrument when the supply voltage falls below a critical value. When this happens, the Oven Controller is disabled and the IN CAL indicator is latched off. The reset circuit is used to turn the IN CAL indicator back on after standardization has been re-verified by qualified personnel. The Voltage Monitor is located on the A4 Regulator PCB.

3-16. Transistor Q8 is turned on by the voltage drop across the Regulator circuit series-pass transistor. This causes switching transistor Q5 to saturate, supplying power to the Oven Controller circuit and the IN CAL indicator circuit. When the output falls below that needed for normal operation, Q8 and Q5 turn off, shutting down the Oven Controller and removing drive from Q7, a Programmable Unijunction Transistor (PUT). This

removes the drive from Q6, shutting off the IN CAL indicator on the front panel. When power is restored, Q7 remains latched off until its emitter is connected momentarily to the COMMON output terminal via the RESET connection, accessible through the front panel.

3-17. Reference Circuit, A5

3-18. The Reference Circuit (A4Q12, Q1, Q2, Q5, U1, U2) reduces the 18.6V output of the Regulator to precisely 10V. The Reference circuit is a highly stable series-pass voltage regulator. The entire reference supply (except the pass transistor) is enclosed in an oven to provide the consistent thermal environment necessary for the stability of the output.

3-19. U2, the Ref-Amp, is a transistor and zener diode mounted on a common substrate. This construction compensates for ambient temperature changes, thus U2 has an extremely low temperature coefficient. The Ref-Amp compares the 10V output to its internal zener reference to derive an error voltage which is amplified by op amp U1. U1 drives the series pass element (Q1, A4Q12). Q2 provides current limiting to protect the series pass element under short circuit conditions. Variable resistor R20 allows a small adjustment (± 50 μ V) in the output voltage of the Reference. Larger adjustments can be made by jumper changes on the Calibration PCB Assembly, A7.

3-20. Output Divider

3-21. Two precision resistive voltage dividers divide the precise 10V output down to 1V and 1.018V. Each of these dividers is adjustable over a limited range to allow calibration. Both dividers are enclosed in the oven with the reference.

3-22. Oven Controller

3-23. The Oven Controller (A4Q13, A4Q14, Q3, Q4, U3, U4, U5) maintains the internal temperature of the oven at a nominal temperature of $48 \pm 2^\circ\text{C}$. The Oven Controller is a high thermal gain, proportional control circuit. The Oven Controller circuit is partially located on

the A5 Reference PCB assembly, inside of the oven. The oven driver and output transistors are located on the A4 Regulator PCB assembly.

3-24. Thermistors RT1, series connected RT2, and RT3 are connected in a bridge configuration with R28 and R29, and are located inside the oven. U3 buffers the bridge output and drives differential amplifier/integrator U5 which drives the oven driver and output transistors (A4Q13, A4Q14) and subsequently the oven heaters. U4 shapes the overall loop frequency response.

3-25. Battery Charger

3-26. The battery charger determines the state of the charge of the internal battery and sets the charging current accordingly: constant current charging for deep discharge or constant voltage trickle charging for charge maintenance. The Battery Charger circuit is located on A3.

3-27. Transistor Q2 is a current source that supplies all the charging current. Transistors Q3 and Q4 form a schmitt trigger. Transistor Q6 supplies a constant voltage output for trickle charging and thus maintains the battery at full charge. Three thermistors monitor the ambient temperature (RT1) and the battery temperature (A6RT1, A6RT2) and adjust the charging rate accordingly.

3-28. During initial charging, Q3 enables Q2 and the high charge rate. When the battery voltage rises to approximately 32V, Q4 turns off, shutting off the constant current charge. The battery is then constant voltage charged by Q6 (approximately 27V at 23°C). Potentiometer R10 sets the threshold point of this transition and hence the end of charge current. At this point, Q6 supplies a constant voltage trickle charge to the battery and R20 sets this voltage level. Thermistor A3RT1 compensates the constant voltage charging for variations in the ambient temperature. Thermistors RT1 and RT2, located on the battery PCB, and Q5 prevent high current charging at temperatures below 5°C , and/or high temperatures.

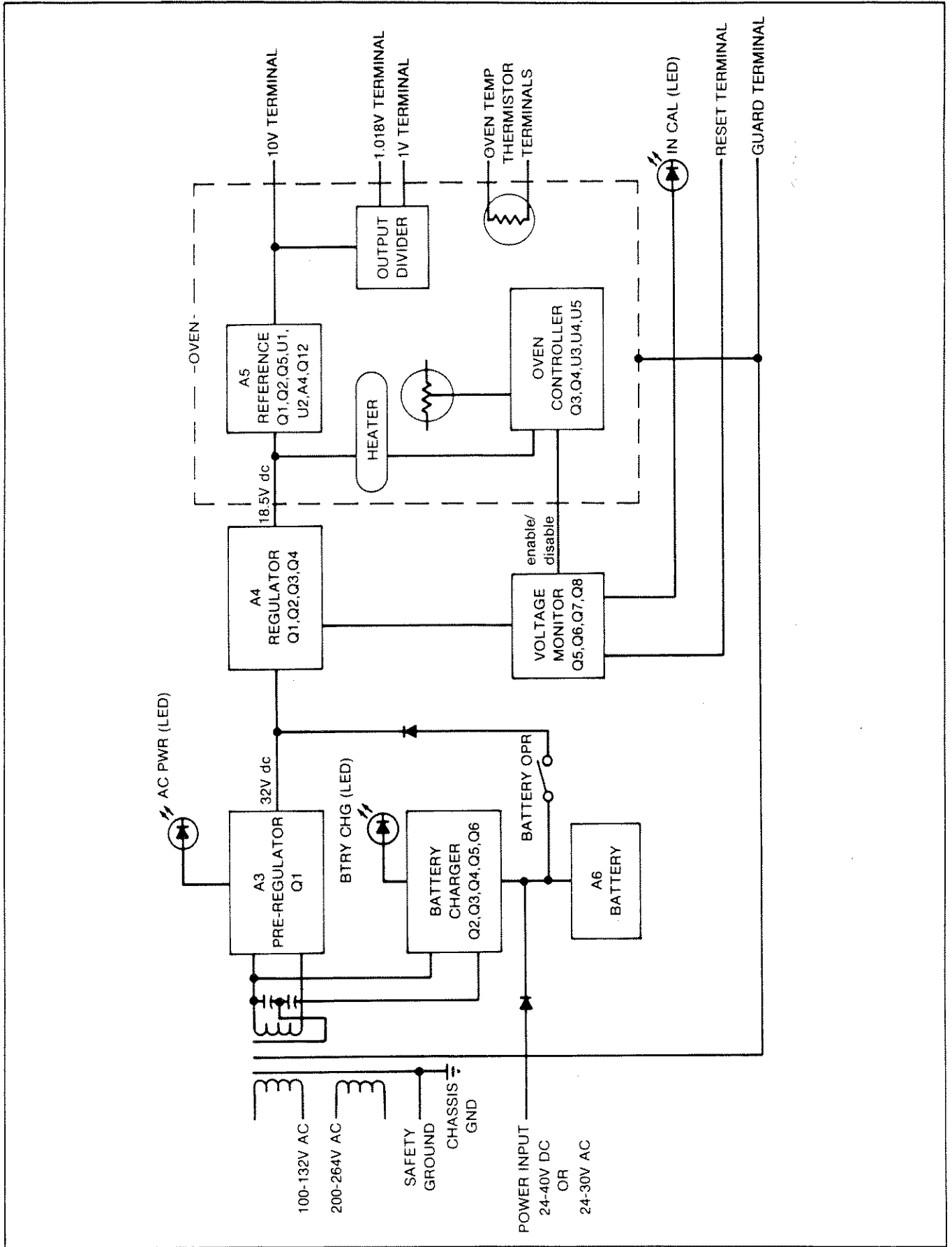

Figure 3-1. Functional Block Diagram

1
2
3
4
5
6
7
8
9
10
11
12
13
14
15
16
17
18
19
20
21
22
23
24
25
26
27
28
29
30
31
32
33
34
35
36
37
38
39
40
41
42
43
44
45
46
47
48
49
50
51
52
53
54
55
56
57
58
59
60
61
62
63
64
65
66
67
68
69
70
71
72
73
74
75
76
77
78
79
80
81
82
83
84
85
86
87
88
89
90
91
92
93
94
95
96
97
98
99
100

Section 4 Maintenance

WARNING

THESE SERVICING INSTRUCTIONS ARE FOR USE BY QUALIFIED PERSONNEL ONLY. TO AVOID ELECTRICAL SHOCK, DO NOT PERFORM ANY SERVICING OTHER THAN THAT CONTAINED IN THE OPERATING INSTRUCTIONS UNLESS YOU ARE QUALIFIED TO DO SO.

4-1. INTRODUCTION

4-2. This section of the manual contains maintenance information for the 732A. This includes general maintenance procedures, an acceptance test, calibration test, calibration procedures and troubleshooting information.

4-3. The acceptance test is used as a means of verifying that the instrument is operating within specifications. Perform the acceptance test upon receipt of the instrument.

4-4. The instrument should be calibrated at an interval commensurate with the users accuracy and stability requirements. Necessary test equipment is listed in Table 4-1. Equivalent instruments may be used, provided that they meet the minimum specification(s).

NOTE

To limit thermally induced errors, use Fluke Low Thermal EMF Assembly Cable (an accessory) or copper wire, preferably shielded twisted pair, with crimped and soldered low-thermal lugs, clamped in the binding posts for all interconnections. Avoid the use of ordinary nickel-plated banana plugs.

CAUTION

To avoid cracking the plastic binding post insulator, tighten only with finger pressure. Do not use tools.

4-5. SERVICE INFORMATION

4-6. The 732A is warranted for a period of one (1) year upon delivery to the original purchaser. The WARRANTY is given on the back of the title page located in the front of this manual.

4-7. Factory authorized calibration and service for each Fluke product is available at various worldwide locations. A complete list of Fluke service centers is included with this manual. Shipping information is given in Section 2 of this manual. If requested, an estimate will be provided to the customer before any repair work is begun on instruments that are not currently under warranty.

4-8. GENERAL MAINTENANCE

4-9. Access Procedure

4-10. Use the following procedures to disassemble the 732A for adjustment or repair. Disconnect ac power connections before disassembling the 732A.

Table 4-1. Required Test Equipment

TYPE	REQUIRED SPECIFICATIONS	RECOMMENDED MODEL	PROCEDURE*
Certified 732A	As required by the user	Fluke 732A**	A, B
Four to Nine Cell Bank of Standard Cells	As required by the user 9152P/4 or 9	Guildline Instruments	A, C
Voltage Divider	7 decade, 0.1 ppm resolution 0.1 ppm absolute linearity	Fluke 720A	C
Null Detector	1 μ V full-scale sensitivity. 10 M Ω input resistance. ZERO/OPR switch must open circuit input terminals in ZERO position.	Fluke 845AB, AR	B, C
Adjustable Source	10V dc output 1 μ V resolution 0.3 ppm + 2 μ V uncertainty	Fluke 5440A	C
Multimeter A	4½-digit display 20 k Ω resistance range 200 mV to 200V ac or dc	Fluke 8050A, 8060A	A, D, E
Multimeter B	6½-digit display 10V dc range, 100 μ V resolution 1V dc range, 10 μ V resolution	Fluke 8500A, 8502A	B, E
Rheostat	50 k Ω , ½W	Fluke P/N 484089	D
Variac	120V, 1A, metered	GenRad W5MT3A	D
Load Resistor	1 k Ω , ½W Carbon Composition	Fluke P/N 108597	B, D
Adjustment Tool	Supplied with 732A	Fluke P/N 686113	A,B,C
<p>* A = Acceptance Test B = Calibration, procedure A. C = Calibration, procedure B. D = Battery charger adjustment E = Troubleshooting</p> <p>**The 732A selected for use as the Certified 732A in Calibration Procedure A should be calibrated at a calibration facility whose transfer uncertainties are consistent with the user's needs.</p>			

4-11. COVER REMOVAL

4-12. Use the following procedure to access the interior of the 732A (Refer to Figure 4-1)

1. Remove all screws securing the top and/or bottom cover(s).
2. Lift the cover(s) off the instrument.

4-13. REAR MODULE REMOVAL

4-14. There are two modules located in the rear of the 732A; The AC Module and the Battery Module. Use the following procedure to remove either of the rear modules (Refer to Figure 4-2):

4-2

NOTE

Either module, but NOT both, may be removed without loss of standardization. If the AC Module is removed, ensure that the rear panel, BATTERY OPR switch is set to ON and that the battery is charged before removing the AC Module. This will insure continued standardization.

1. Remove the screws securing the module to the rear of the instrument.
2. Pull the module out from the rear of the instrument.

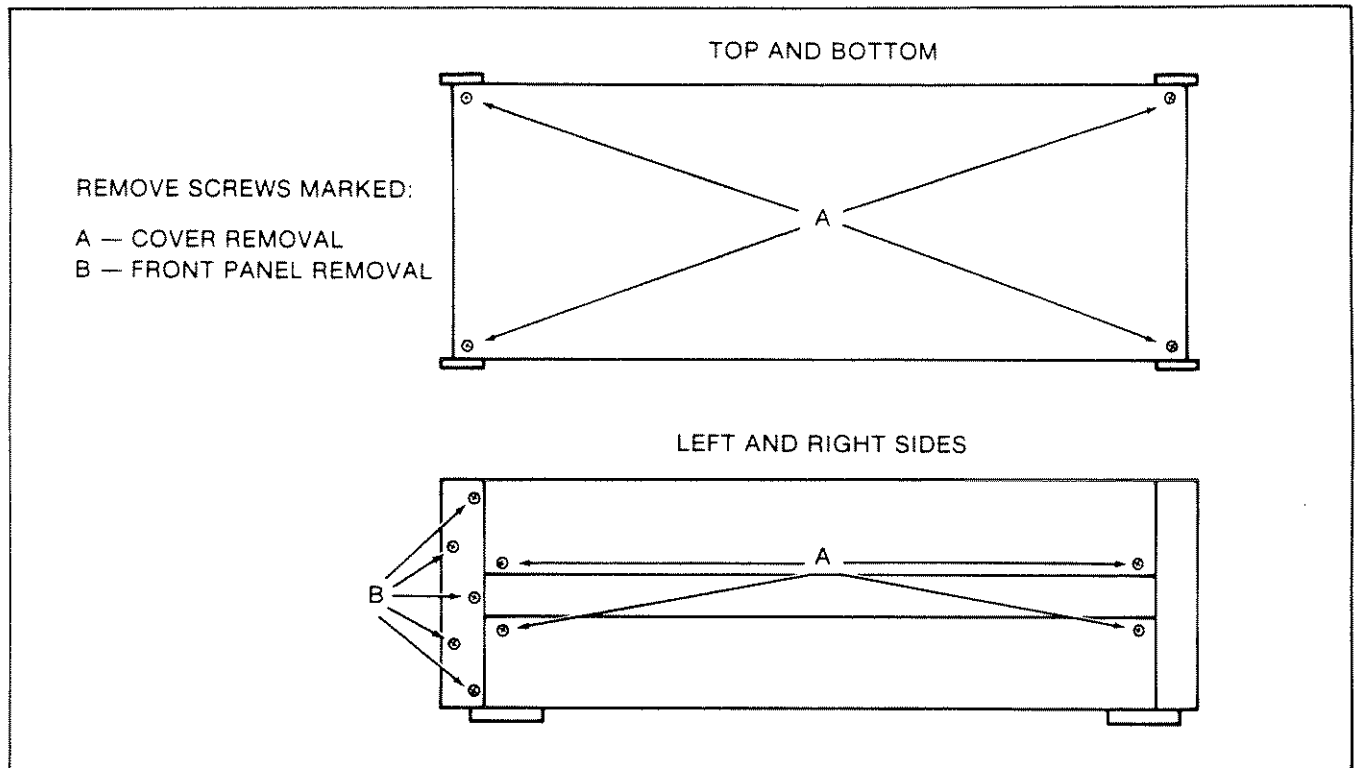

Figure 4-1. Cover and Front Panel Screw Locations

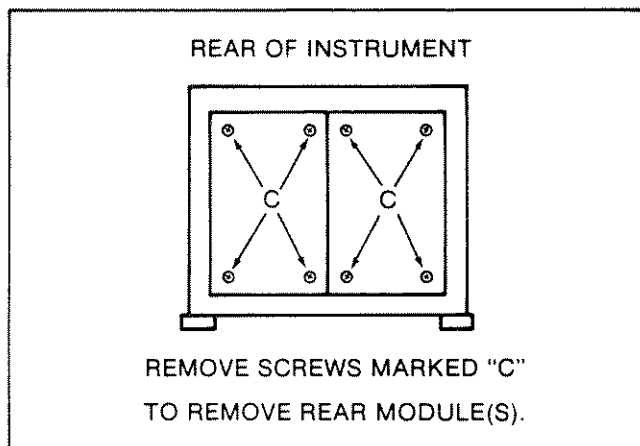

Figure 4-2. Rear Module Mounting Screw Locations

4-15. REGULATOR PCB ASSEMBLY REMOVAL

NOTE

Since the Regulator PCB Assembly removal requires the removal of BOTH rear modules, standardization will not be maintained after this procedure.

4-16. Use the following procedure to remove the Regulator PCB Assembly from the 732A (Refer to Figure 4-3).

1. Remove the top and bottom covers.

2. With the 732A resting on its bottom, remove the screws securing the inner shield top cover and remove the shield.

3. Remove both of the rear modules.

4. Remove the screws that fasten the two T0-220 power transistors to the bottom of the chassis. Save the two insulators and the two shoulder washers. Note the positions of the insulating hardware so they can be reassembled properly.

5. Unplug the Regulator PCB Assembly from the motherboard by pulling it out towards the rear of the 732A.

4-17. OVEN REMOVAL

4-18. Use the following procedure to remove the oven assembly from the 732A (Refer to Figure 4-4)

1. Remove the top and bottom covers.

2. With the 732A resting on its bottom, remove the screws securing the inner shield cover and remove the cover.

3. Carefully pry the top foam insulating block out from the front of the instrument using a blade type screwdriver.

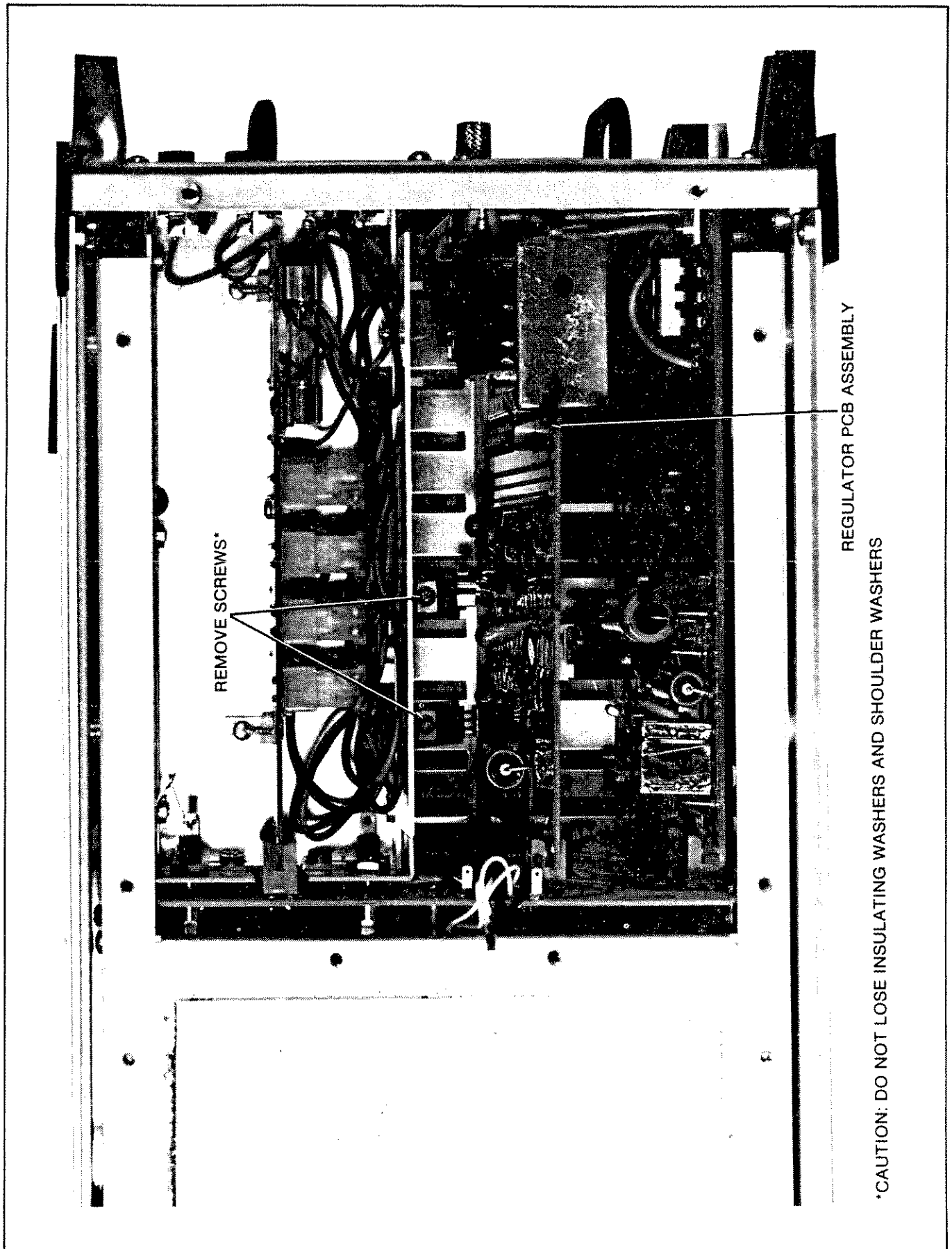

REMOVE SCREWS*

REGULATOR PCB ASSEMBLY

*CAUTION: DO NOT LOSE INSULATING WASHERS AND SHOULDER WASHERS

Figure 4-3. Regulator PCB Assembly Removal

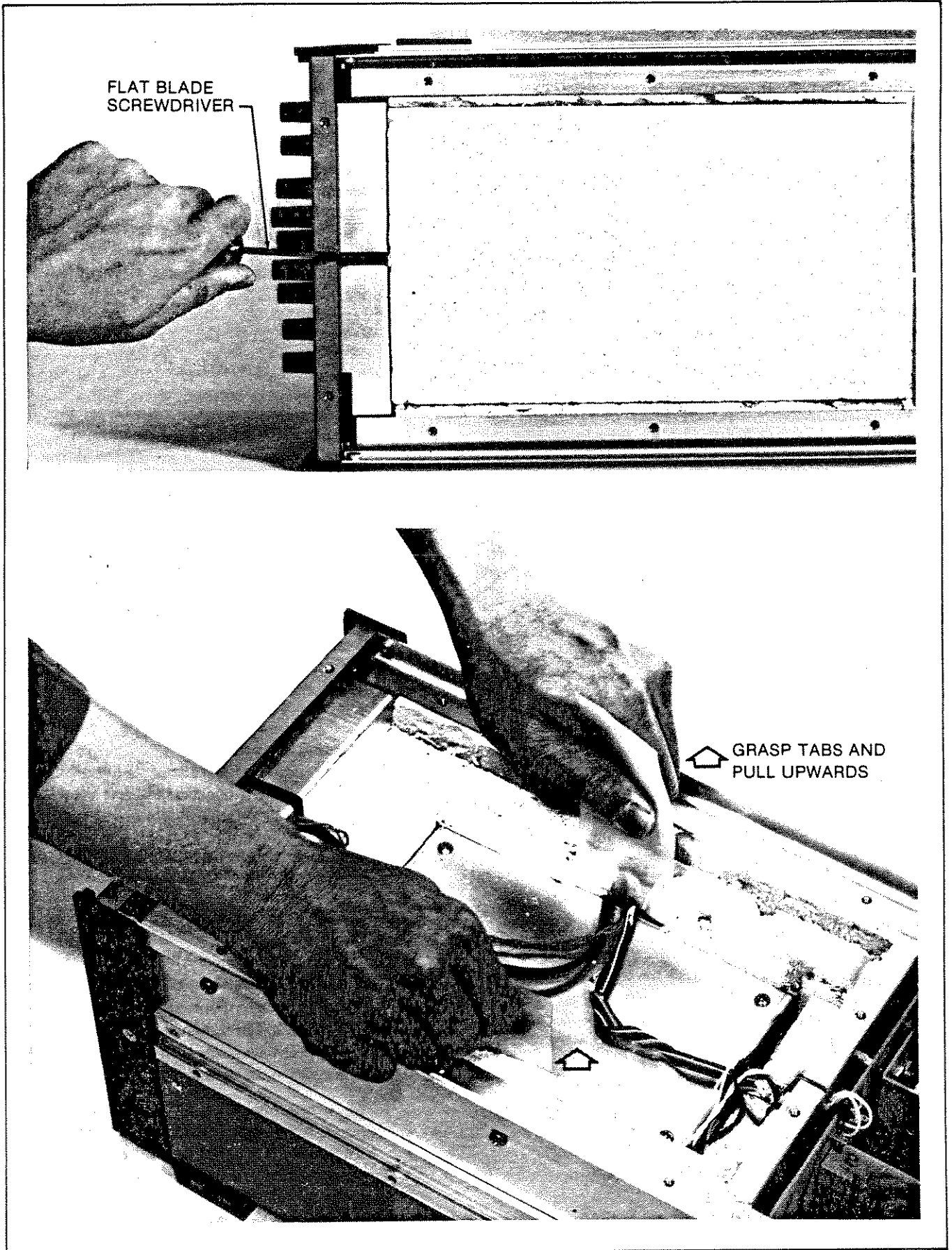

Figure 4-4. Oven Assembly Removal

4. Do the same for the foam block that is now exposed.
5. Locate the two mylar tabs located on each side of the Oven Assembly.
6. Grasp both mylar tabs and pull steadily and evenly upwards.
7. Disconnect the Oven Assembly cable harness at the motherboard and at the front panel.

4-19. Oven Disassembly

4-20. Use the following procedure to disassemble the Oven Assembly. Use this procedure only if access is necessary to effect repairs on the Oven Controller circuit. Do not attempt to repair the Reference circuit.

1. Remove the Oven Assembly from the 732A.
2. Lay the instrument on its side, with its top facing you, and lay the Oven Assembly on the work surface.
3. Remove the four screws holding the inside clamshell (the inside clamshell contains the adjustment holes for the calibration potentiometers)

NOTE

Do not turn the screws on the outside clamshell as this will cause difficult disassembly and reassembly.

4. Move the wire bundle to the side and lift the heater assembly free of the Oven Assembly.
5. Lay the heater assembly to the side. The Reference PCB Assembly circuitry is now accessible.

NOTE

In most cases, repairs to the PCB assembly can be better accomplished from the component side of the PCB. If access to the bottom of the PCB is necessary, unscrew the outside four teflon standoff.

4-21. Front Panel Removal

4-22. Use the following procedure to detach the front panel from the 732A:

1. Remove the top and bottom covers.
2. With the 732A resting on its bottom, remove the screws securing the inner shield cover and remove the cover.

3. Locate the Blue wire coming from the GUARD terminal to a solder lug riveted to the chassis. Unsolder this wire at the solder lug and pull it free.

4. Peel the decal from both of the front corner side moldings and remove the exposed screws. Refer to Figure 4-1 for screw locations.

5. Remove the front corner side moldings from the instrument.

6. The front panel is now free. Be extremely careful of the wire harness connected to the front panel binding posts. The service loop provided is quite limited.

4-23. Cleaning

CAUTION

To prevent possible damage to the front panel, do not use aromatic hydrocarbons or chlorinated solvents on the front panel of the 732A.

4-24. When the 732A is properly cared for and kept in a controlled atmosphere, cleaning is seldom required. However, any contamination, particularly oil, in the instrument can contribute to an increase in leakage which may impair accuracy.

4-25. Clean the exterior and the front panel of the 732A with a soft cloth dampened in a mild solution of detergent and water. Do not attempt to clean the interior of the instrument.

4-26. Fuse Replacement

4-27. The power fuse F1 is located on the rear panel of the 732A. If replacement is necessary, use the following rated fuses:

100V or 120V ac operation – MDL 3/8 (3/8A slow blow)

230V or 240V ac operation – MDL 3/16 (3/16A slow blow)

4-28. AC Line Voltage Change

4-29. The 732A may be operated from 100V, 120V, 220V, or 240V ac $\pm 10\%$. The assigned line voltage may be changed to match the available source using the following procedure. Refer to Figure 4-5.

1. Ensure that the battery is charged or an appropriate external ac or dc source is connected to the POWER INPUT jacks on the rear panel. This will maintain the unit's standardization when ac line power is removed. The BTRY CHG indicator on the front panel will extinguish when the battery is fully charged and the 732A is still connected to the ac power source.

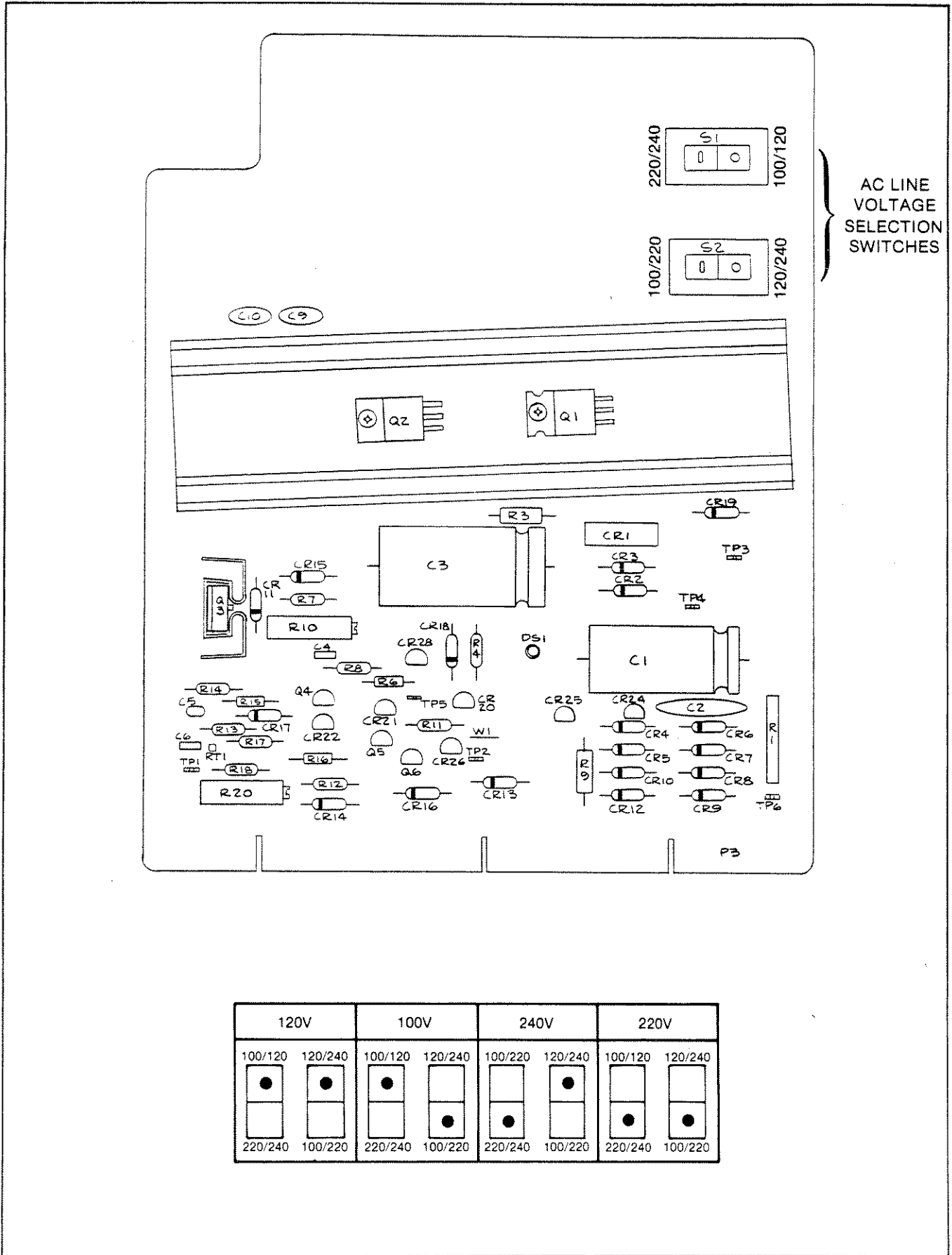

120V		100V		240V		220V	
100/120	120/240	100/120	120/240	100/220	120/240	100/120	120/240
<input checked="" type="checkbox"/>	<input checked="" type="checkbox"/>	<input checked="" type="checkbox"/>	<input type="checkbox"/>	<input type="checkbox"/>	<input checked="" type="checkbox"/>	<input type="checkbox"/>	<input type="checkbox"/>
<input type="checkbox"/>	<input type="checkbox"/>	<input type="checkbox"/>	<input checked="" type="checkbox"/>	<input checked="" type="checkbox"/>	<input type="checkbox"/>	<input checked="" type="checkbox"/>	<input checked="" type="checkbox"/>
220/240	100/220	220/240	100/220	220/240	100/220	220/240	100/220

Figure 4-5. AC Line Voltage Conversion on A3 Pre-Regulator PCB Assembly

2. Set the BATTERY OPR switch to ON and remove ac line power from the instrument.
3. Remove the AC Module.
4. Locate the voltage selector switches (slide switches, top of PCB, near rear panel). Set the switches so that the dots on the switch actuators select the correct line voltage. As shown in Figure 4-5.
5. Reinsert the AC Module, replace the screws.
6. On the rear panel, change the mark to the appropriate box, under the SUPPLY/SETTING heading, to indicate the present power configuration.
7. Replace the line fuse with one of appropriate value.
8. After verifying that the local ac line voltage matches the voltage selected on the 732A, apply ac line power to the instrument.

4-30. ACCEPTANCE TEST

4-31. Use the following procedure to verify that the instrument is operational. The required test equipment is listed in Table 4-1. Equivalent instruments may be used, provided the minimum specification is met.

1. Check the IN CAL indicator on the front panel. If illuminated, proceed to step 2. If not, complete steps a through f.
 - a. If the IN CAL indicator was not lit, set the rear panel BATTERY PWR switch to OFF and apply ac power to the instrument using the Variac, to the Supply Setting limit listed on the rear panel.
 - b. Adjust the Variac for 120V ac output. The ac line current should be less than 0.3A.
 - c. Set the BATTERY PWR switch to ON. The ac line current should be less than 0.35A if the battery is dead (BTRY CHG indicator blinking). If BTRY CHG indicator is on steadily, the ac line current should be less than 0.35A.
 - d. Allow the 732A to stabilize (under power) for 24 hours.
 - e. If a standards laboratory is available, perform the External Calibration Procedure described in Section 4. If a standards laboratory is not available, send the 732A to a Fluke Technical Service Center or an independent standards laboratory for calibration.

f. Once the 732A has been calibrated, proceed to step 2.

2. Apply ac power of the correct voltage and frequency to the instrument. The AC PWR and BTRY CHG indicators should both be on.
3. Measure the value of the Oven Temperature Thermistor at the front panel binding posts with Multimeter A. The value should be within ± 1 ohm of the value shipped with the instrument.
4. Check the output voltage at the 10V output using Multimeter A. It should be accurate within the performance limitations of the Multimeter.
5. Measure the change in output voltage under load. To make this measurement correctly, wire Multimeter A to the 10V and 10V LO binding posts (do not use plugs) and measure the voltage. Then plug the 1000 ohm load into the same binding posts and measure the voltage. The voltage change should be less than 50 μ V or 5.0 ppm.
6. Repeat step 4 for the 1V and 1.018V outputs.
7. If a standards laboratory is available, verify stability by comparison to standard cells or another pre-certified 732A. This step is optional.
8. The instrument is operational.

4-32. CALIBRATION

4-33. Complete either of the following calibration procedures to certify the 732A. Procedure A uses direct comparison between the Unit Under Test (UUT) and a Certified 732A to calibrate the 10V output. The 10V output of the UUT is then transferred to a stable adjustable voltage source. The voltage source is then divided down, as required, for comparison with the UUT 1.018V and 1V outputs. Procedure B transfers the voltage from a bank of standard cells to a stable adjustable voltage source, then divides the voltage source down, as required, for comparison with the UUT.

4-34. Either procedure may be used, taking into account the available test equipment and the degree of accuracy needed. The necessary equipment for each procedure is listed in Table 4-1.

4-35. Null Verification

4-36. Use the following procedure to verify the accuracy of null in the calibration procedures. The Null Verification procedure identifies the thermal voltages present and allows the null adjustment to be made independently of them. Use the Null Verification procedure in the two calibration procedures (Procedures A and B) when instructed to "verify the null".

1. Adjust the UUT for zero on the Null Detector.
2. Reverse the HI and LO (positive and negative) leads on the UUT and RU (Reference Unit).
3. Observe the Null Detector reading. If the reading does not equal zero, adjust the UUT for one-half of the Null Detector reading.
4. Reverse the HI and LO (positive and negative) leads on the UUT and Certified 732A. The Null Detector should have the same reading as it did at the end of step 3. If not, adjust the UUT for one-half the difference.
5. Repeat steps 2 through 4 until the Null reading does not change when the UUT and Certified 732A leads are reversed.
6. The residual reading on the Null Detector equals the sum of the thermal voltages in the circuit.
4. Set OPR switch on the Null Detector to the ZERO position, then switch power on. Adjust the Null Detector for zero on the 3 μV range.
5. Set the Null Detector to the 30 μV range and the OPR switch to OPR.
6. Decrease the range setting on the Null Detector slowly while adjusting the 10V calibration potentiometer, through the front panel opening on the UUT, for a null indication on the Null Detector on the 3 μV range. Let the system stabilize for about 1 minute before adjustment. Use the non-conducting adjustment tool supplied with instrument.
7. Verify the null.
8. Connect the equipment as shown in Figure 4-7. Set the Precision Divider ratio switches to 0.999999X.
9. Adjust the Adjustable Source for a null indication.
10. Verify the null.
11. Connect the equipment as shown in Figure 4-8. Set the Precision Divider ratio switches to 0.1018000.
12. Set the Null Detector RANGE switch to the 3 volt range, then connect the Input lead to the UUT 1.018V terminal. Switch the Null Detector to OPR.
13. Adjust the 1.018V calibration potentiometer on the UUT while decreasing the RANGE setting on the Null Detector to obtain a null on the 3 μV range. Use the non-conducting adjustment tool.

4-37. Procedure A: Calibrate to Certified 732A

4-38. Complete the following procedure to standardize the outputs of the 732A to a Certified 732A. Battery operation of the 732A and 845AB/AR is preferred. Set the Null Detector to ZERO when changing leads. Use the supplied adjustment tool for all adjustments (Fluke P/N 686113).

1. Perform the self-calibration procedure on the Precision Divider immediately prior to this procedure.
2. Obtain a certified 732A.
3. Connect the UUT and the Certified 732A as shown in Figure 4-6.

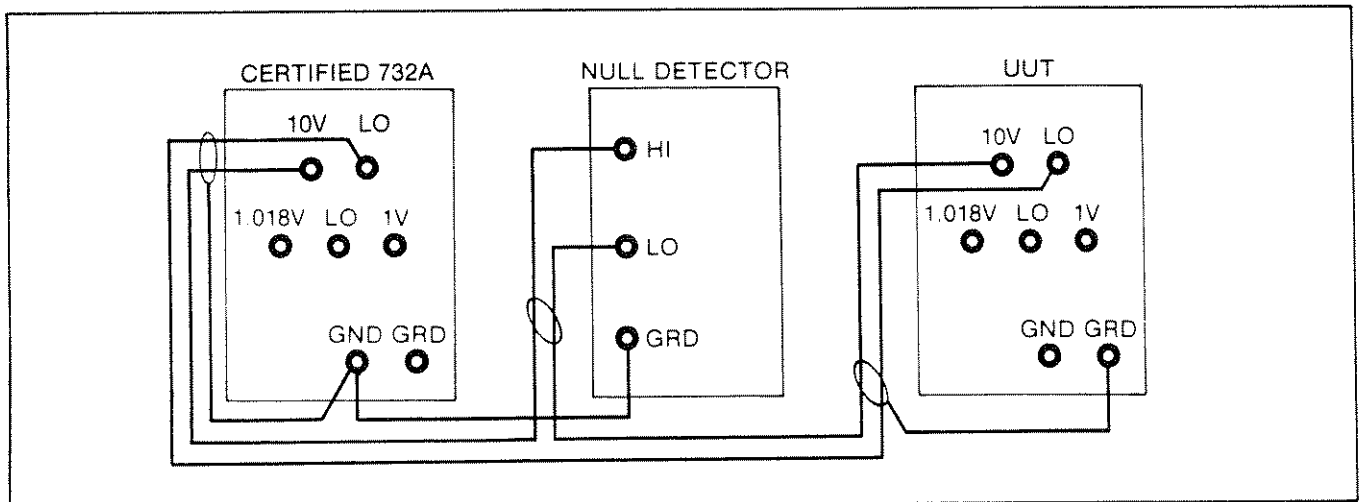

Figure 4-6. 732A Procedure 'A' 10V Calibration

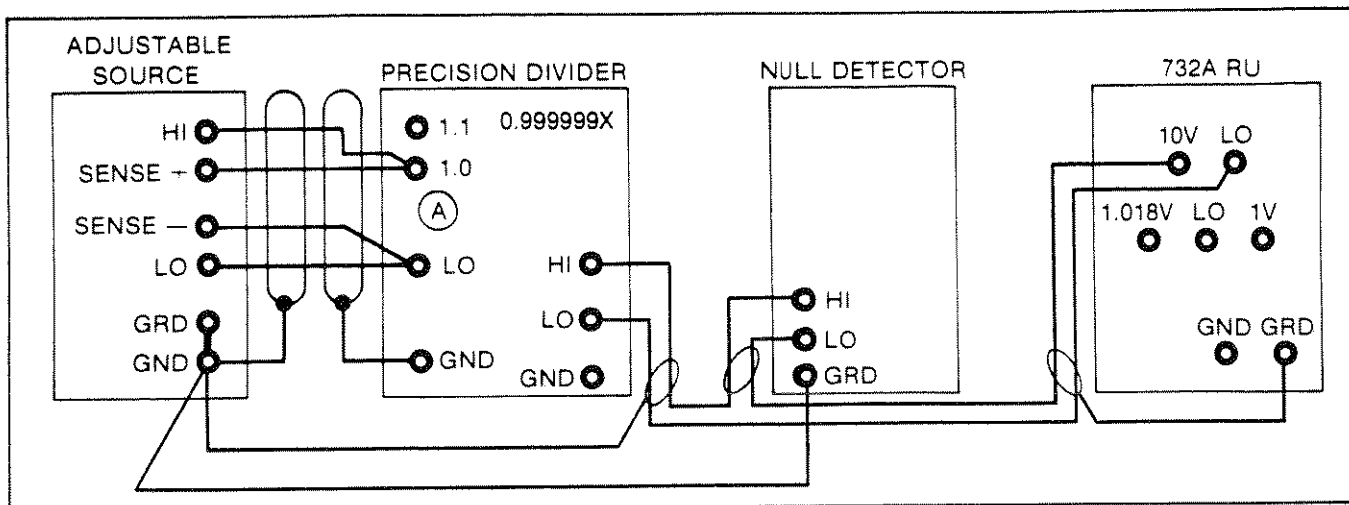

Figure 4-7. Calibration of Point A to 10V Using 732A

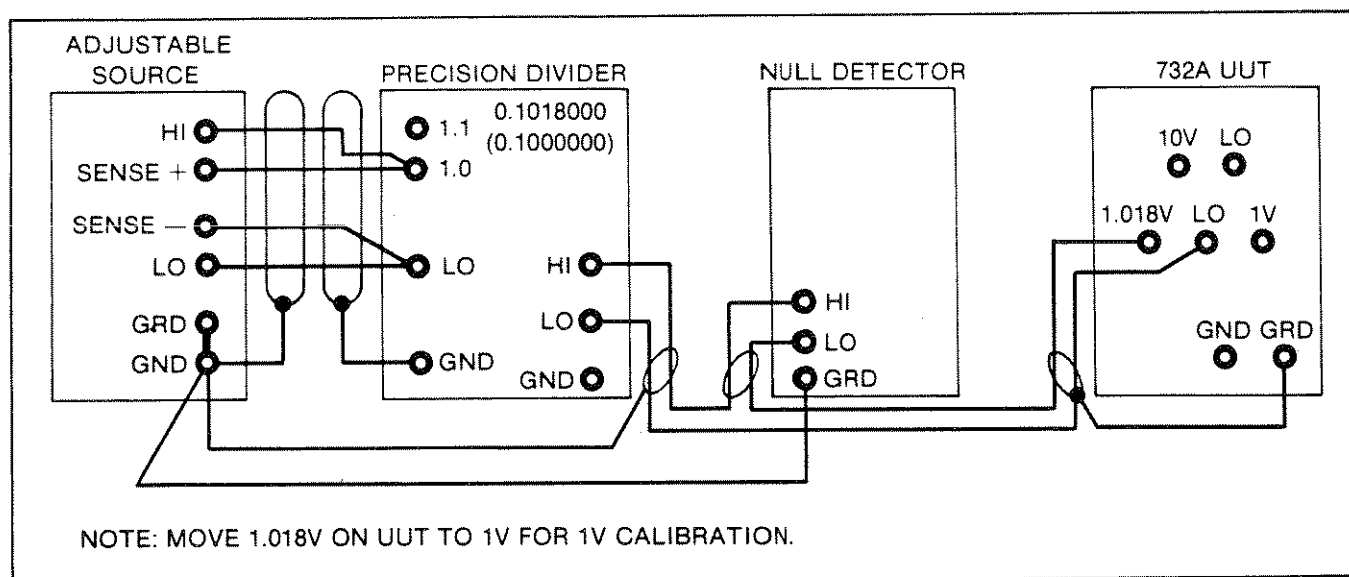

Figure 4-8. Calibration of 1.081V (and 1V) to 732A Procedure 'A'

14. Verify the null.
15. Set the Precision Divider ratio switches to 0.1000000.
16. Transfer the Null Detector input lead from the 1.018V terminal to the 1V terminal on the UUT.
17. Set the RANGE control on the Null Detector to the 3 volt position. Adjust the 1V calibration potentiometer on the UUT while decreasing the RANGE setting on the Null Detector to obtain a null on the 3 μ V range. Use the non-conducting adjustment tool.
18. Verify the null.
19. If the IN CAL indicator is illuminated, proceed to step 20. If not, connect a short wire to

one of the front panel COMMON terminals. Momentarily touch the other end of this wire to the circuit board behind the RESET hole. The IN CAL indicator should illuminate.

20. Calibration is complete. Record all test results. Disconnect all test equipment. Cover the output adjustment access holes and the RESET hole with tamper-proof calibration seals.

4-39. Procedure B: Calibration to Standard Cells

4-40. Use the following procedure to standardize the output of the 732A. Set the Null Detector to ZERO when changing leads or when not making measurements to avoid accidental damage to the Standard Cells. Observe the techniques presented in Section 2 for minimizing thermal emf errors.

CAUTION

To prevent damage to the standard cells, the null detector used must open circuit its input leads when the ZERO/OPR Switch is set to the ZERO position.

1. Perform the self-calibration procedure on the Precision Divider immediately prior to this procedure.
2. Measure the standard cell enclosure temperature per the manufacturer's instructions and compute the voltage of up to 9 standard cells connected in series. Call this voltage S.
3. Set the Null Detector to the ZERO position.
4. Connect the equipment as shown in Figure 4-9A.
5. Adjust the ZERO control on the Null Detector for a zero indication on the 3 μ V range.
6. Set the RANGE switch to the 300uV range.
7. Set the Precision Divider ratio switches to S/10.
8. Adjust the Adjustable Source for precisely 10V output.
9. Set the Null Detector to OPR. If the Null Detector reading exceeds $\pm 300 \mu$ V, quickly return the Null Detector to the ZERO position and determine the reason for the imbalance.

NOTE

If a high degree of imbalance exists, check the output of the Precision Divider at its output terminals using Multimeter A. It should be approximately equal to the total voltage of the Standard Cell bank, or S.

10. Adjust the Adjustable Source for a null indication on the Null Detector. This is a preliminary null.
11. Set the Null Detector to the ZERO position on the 3 uV range. Adjust the ZERO control if necessary for a zero indication.
12. Disconnect the lead going from the positive terminal of the Standard Cells to the Null Detector at the Standard Cell end as shown in Figure 4-9B. Connect this lead to the negative terminal of the

Standard Cells at the standard cell enclosure as shown in Figure 4-9C.

13. Set the Precision Divider ratio switches to 0.000000.
14. Set the Null Detector to the OPR position and wait for a stable reading. Note any offset (residual reading). This reading represents the extraneous and thermal voltages which should be less than 0.5 μ V. If the offset exceeds this value, the cause should be investigated and corrected before proceeding. Adjust the Null Detector ZERO control to obtain a null indication.
15. Return the Null Detector to the ZERO position. Do not disturb the setting of the ZERO control.
16. Set the Precision Divider ratio switches to the previously calculated value of S/10.
17. Reconnect the positive lead of the Standard Cells as shown in Figure 4-9A.
18. Readjust the Adjustable Source, if necessary, for a null indication on the 3 μ V range of the Null Detector.
19. Do not change the setting on the Adjustable Source or the leads to the Precision Divider.
20. Connect the equipment as shown in Figure 4-10.
21. Repeat steps 12 through 15 for the UUT. In Step 12, move the lead from the 10V HI terminal to the 10V LO terminal of the UUT.
22. Set the Precision Divider ratio switches to 0.999999X.
23. Set the Null Detector to the 300 μ V range and set the OPR/ZERO switch to the OPR position.
24. Decrease the range setting on the Null Detector slowly while adjusting the 10V calibration potentiometer, through the front panel opening on the UUT, for a null indication on the Null Detector. Use the non-conducting adjustment tool supplied with the instrument.
25. Adjust the 10V calibration potentiometer to obtain a null indication with the Null Detector on the 3 μ V range. Let the system stabilize for about 1 minute before adjustment.
26. Connect the equipment as shown in Figure 4-11. Reset the Null Detector to the 3V range.

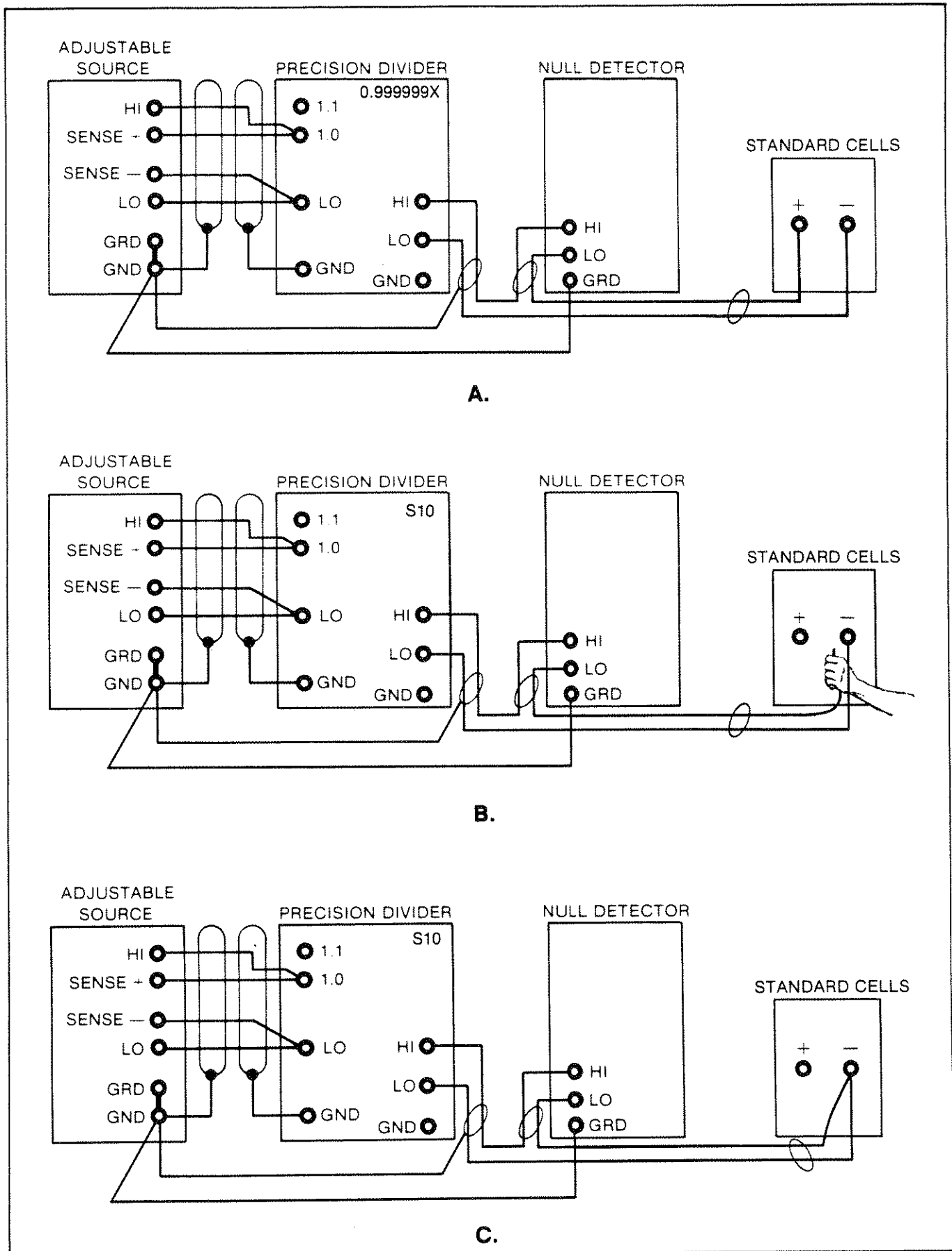

Figure 4-9. 732A 10V Calibration Using Standard Cells

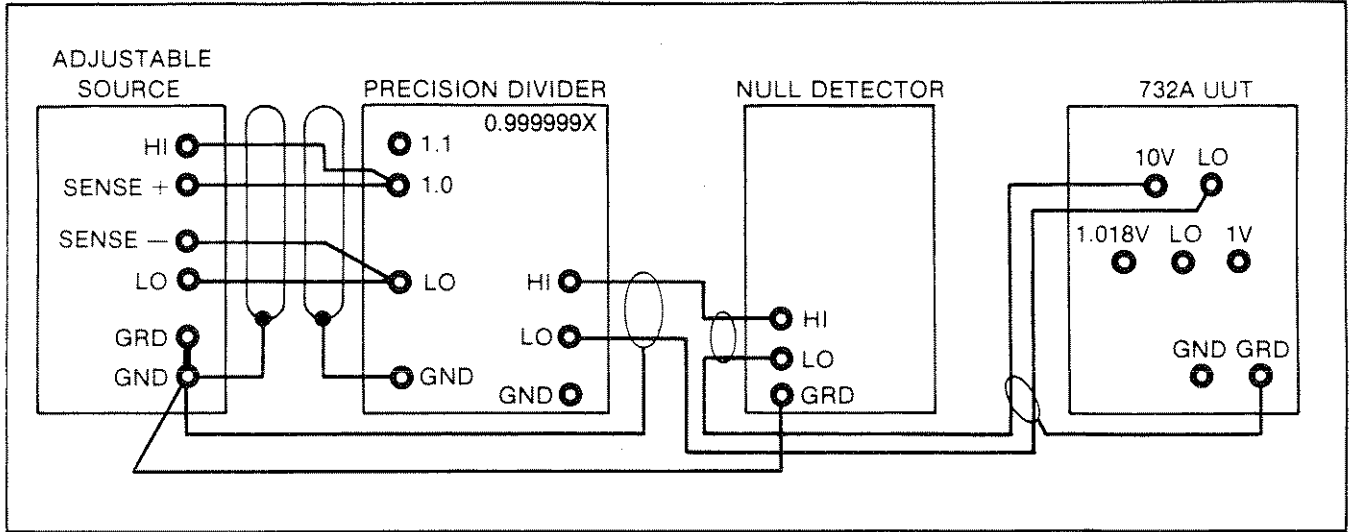

Figure 4-10. 732A Procedure 'B' 10V Calibration

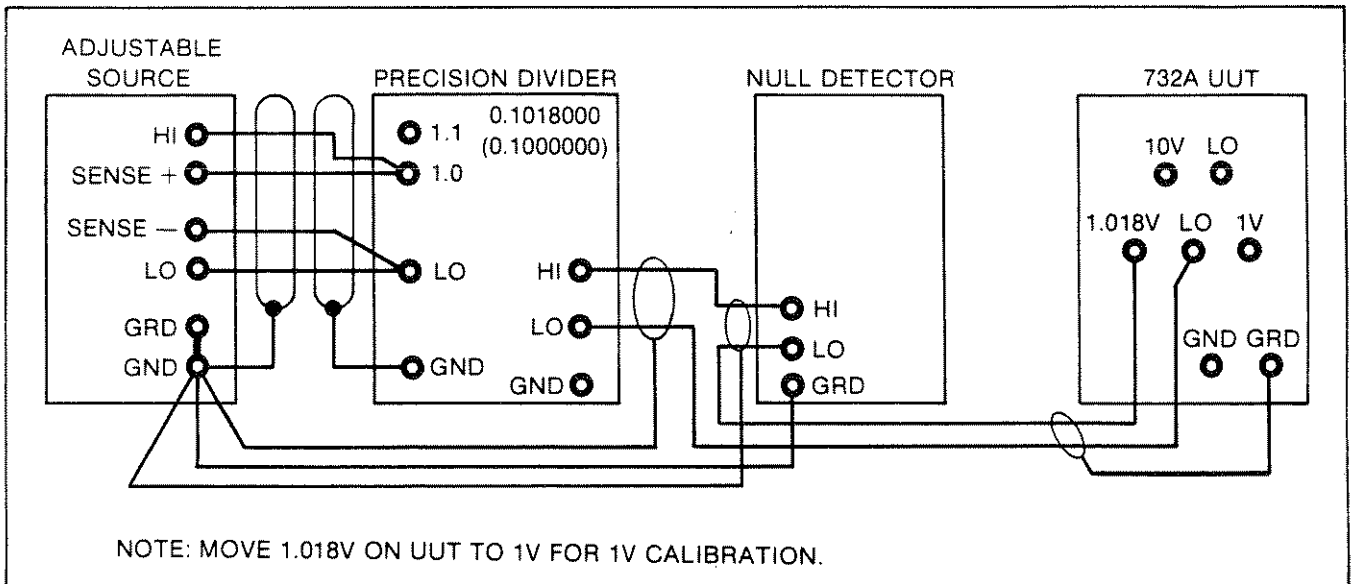

Figure 4-11. Calibration of 1.081V (and 1V) to 732A Procedure 'B'

27. Set the Precision Divider to 0.1018000.
28. Decrease the range setting on the Null Detector slowly while adjusting the 1.018V calibration potentiometer, through the front panel opening on the UUT, for a null indication on the Null Detector. Use the non-conducting adjustment tool supplied with the instrument.
29. Adjust the 1.018V calibration potentiometer to obtain a null indication with the Null Detector on the 3 μ V range. Let the system stabilize for about 1 minute before adjustment. Verify the null.
30. Move the wire connected to the UUT 1.018V output to the UUT 1V output. Reset the Null detector to the 3V range.
31. Set the Precision Divider to 0.1000000.
32. Decrease the range setting on the Null Detector slowly while adjusting the 1V calibration potentiometer, through the front panel opening on the UUT, for a null indication in the Null Detector. Use the non-conducting adjustment tool.
33. Adjust the 1V calibration potentiometer to obtain a null indication with the Null Detector in the 3 μ V range. Let the system stabilize for about 1 minute before adjustment. Verify the null.
34. If the IN CAL indicator is illuminated, go to step 35. If not, connect a short wire to one of the front panel COMMON terminals. Momentarily touch the other end of this wire to the circuit board

behind the RESET hole. The IN CAL indicator should illuminate.

35. Calibration is complete. Record all test results. Disconnect all test equipment. Cover the output adjustment access holes and the RESET hole with tamper-proof calibration seals.

4-41. SERVICE/REPAIR PROCEDURES

4-42. Introduction

4-43. The Battery Charger Adjustment procedure is the only field service procedure for the 732A. There is no field serviceable circuitry within the oven/reference supply assembly. All adjustments within the oven must be made at the Factory or at a Fluke Technical Service Center. The following paragraphs describe the Battery Charger adjustments for the 732A.

4-44. Battery Charger Adjustment Procedure

CAUTION

This procedure will cause loss of standardization. Calibration must be performed before reuse of the instrument.

4-45. Refer to Figure 4-8. Perform this procedure to calibrate the battery charger after repair of the battery charger circuit. The equipment required is listed in table 4-1.

1. Remove ac power from the instrument.
2. Set the BATTERY OPR switch to OFF.
3. Remove the top cover from the instrument.
4. Remove the AC Module from the instrument.
5. Locate test points TP1, TP2, and TP5 on the A3, Pre-Regulator PCB Assembly(part of the AC Module). Locate trimpots R20 and R10 and jumper wire W1, also on the AC Module.
6. Connect a 50 k Ω rheostat between TP1 and TP2. Adjust the Rheostat for maximum resistance.
7. Connect Multimeter A between TP5 and TP1. TP5 is positive with respect to TP1.
8. Reinstall the AC Module in the instrument.
9. Apply ac power to the UUT using the Variac. Adjust the Variac for the line voltage indicated on the rear of the instrument.
10. Adjust R20 for a 33.0V dc reading on Multimeter A.

11. Turn the ac power off by reducing the Variac to zero volts or by unplugging the UUT.

12. Remove jumper W1 on A2.

13. Restore ac power.

14. Connect Multimeter A between TP2 and TP1. TP2 is positive with respect to TP1.

15. Set the BATTERY OPR switch to ON.

16. Set R10 fully clockwise (CW). Multimeter A should read approximately 45 to 50V dc.

17. While observing Multimeter A, adjust the rheostat toward minimum resistance. At approximately 26V dc, the BTRY CHG indicator and CR27 (CR27 is the voltage reference for the constant current source in the battery charger circuit, located on A2) should come on. The ac line current should jump to approximately 110 mA at 115V ac (55 mA at 220V ac).

18. Adjust the Rheostat for a Multimeter A reading of 32V dc.

19. Turn R10 counter-clockwise (ccw) until the BTRY CHG indicator and CR27 go out. Note that the ac line current has dropped.

20. Adjust the Rheostat toward minimum resistance, while observing the BTRY CHG indicator. When the BTRY CHG indicator lights, CR27 lights, and the ac line current increases suddenly, Multimeter A should read between 24.5 and 26.5V dc.

21. Adjust the Rheostat until the BTRY CHG and CR27 indicators turn off. Multimeter A should indicate a dc voltage greater than +31V.

22. Disconnect all test equipment and the rheostat.

23. Remove the AC Module from the 732A.

24. Reinstall jumper W1.

25. Reinstall the AC Module.

26. Battery Charger adjustment is now complete. Perform the Calibration adjustment procedure described earlier in this section.

4-46. TROUBLESHOOTING

4-47. Introduction

4-48. The information in this section describes troubleshooting procedures for the 732A. The section is divided into two parts: External Symptom Troubleshooting and Internal Voltage Measurements.

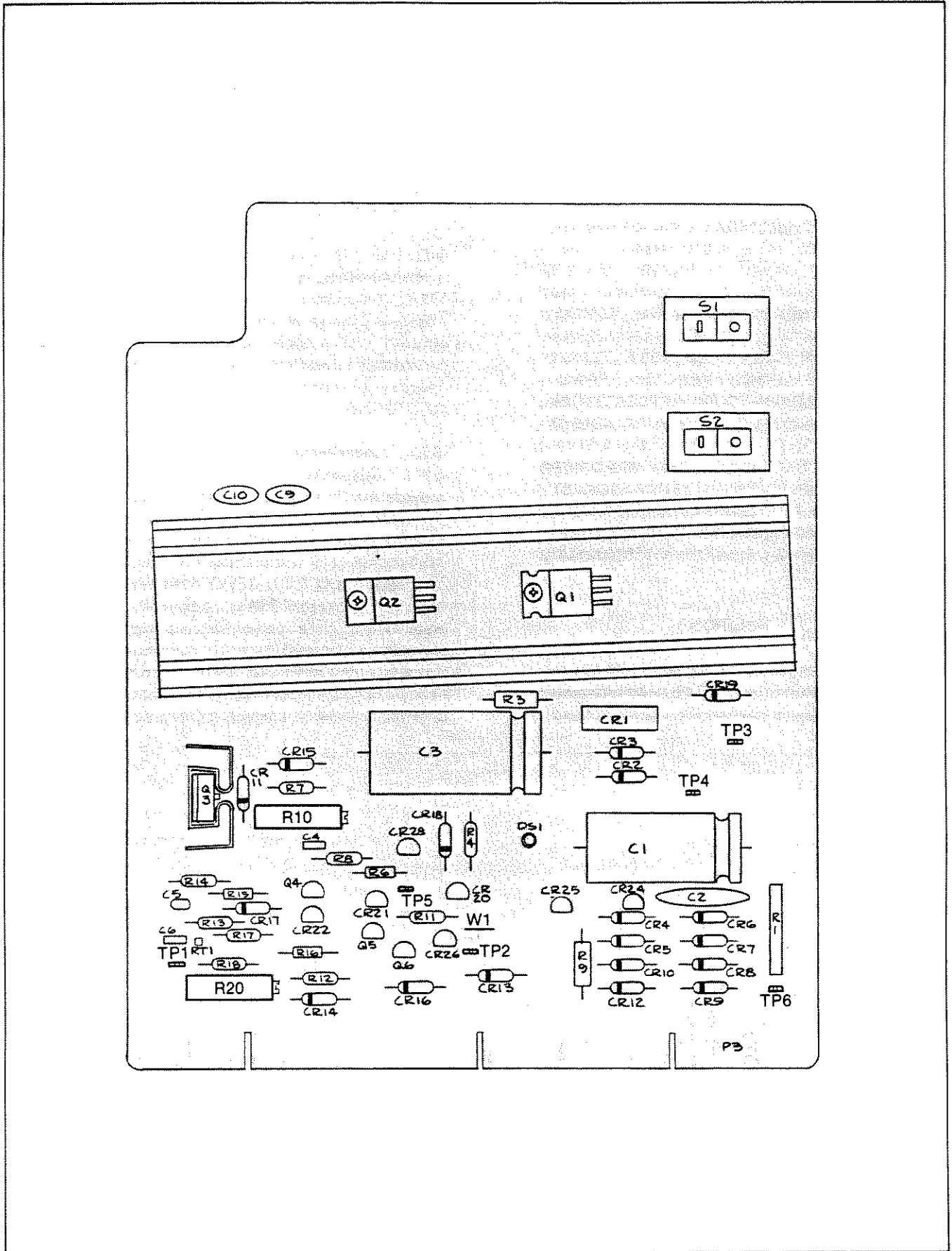

Figure 4-12. Battery Charger Test Points and Adjustments on A3 Pre-Regulator PCB Assembly

4-49. External Symptom Troubleshooting

4-50. Use Table 4-2 to isolate problems within the 732A, using external symptoms. Table 4-1 lists the required test equipment for troubleshooting.

4-51. Internal Voltage Measurements**WARNING**

TO AVOID ELECTRICAL SHOCK HAZARD, OBSERVE THE FOLLOWING PRECAUTIONS WHILE WORKING ON THE INSIDE OF THE 732A. REMOVE ANY JEWELRY BEFORE BEGINNING TESTING. HIGH VOLTAGE AC MAY BE PRESENT DURING THE FOLLOWING TESTS, DO NOT PERFORM ALONE. EXERCISE APPROPRIATE CAUTION TO AVOID ELECTRICAL SHOCK WHEN WORKING IN OR AROUND THE VICINITY OF THE AC POWER CONNECTOR, FUSEHOLDER, AND POWER TRANSFORMER. THE BATTERY ASSEMBLY IS CAPABLE OF GENERATING EXTREMELY HIGH PEAK CURRENTS. AVOID ACCIDENTAL SHORTING OF BATTERY TERMINALS.

CAUTION

The following tests are conducted with power applied to the instrument. To avoid instrument damage, exercise appropriate caution to avoid

inadvertently shorting adjacent test points or circuit board traces with test probes or other instrument(s).

CAUTION

To insure continued instrument performance, do not attempt to replace individual wires in the reference output wiring harness. Replace the entire harness.

4-52. Use the tests shown in Table 4-3 to isolate problems to the major functional circuit groups of the 732A. It is assumed that the external symptoms given in Table 4-2 have been examined and that the primary circuit of the power transformer is operable. This procedure is conducted with the instrument energized, observe the previously stated WARNINGS and CAUTIONS.

4-53. Oven Repair

4-54. Shifts in the output level which cannot be compensated for by adding or removing jumpers from the A7 Calibration PCB will require the entire Oven Assembly to be returned to Fluke and exchanged for a working unit. Do not attempt to repair the circuitry involving U1, U2, Q1, Q2, Q5, the resistors associated with TP11 through TP14, or any other component(s) associated with the aforementioned components. Special procedures and auxiliary test equipment are necessary for component replacement within the Reference circuit. Module exchange is provided as the most economical and expedient method of repair for the user.

Table 4-2. External Symptom Troubleshooting

SYMPTOM	PROBABLE CAUSE	ACTION
732A inoperative.	Fuse blown. Battery dead. Battery opr switch set to OFF. 732A not plugged in.	Check fuse. Measure battery voltage at rear panel jacks. Recharge battery. Visual check. Restore power.
IN CAL indicator off.	Lost ac power, battery dead.	Charge battery, verify instrument calibration.
Repeated fuse blowing.	AC line primary circuit. Power transformer. Bridge rectifier. Battery charger rectifier.	Visual inspection. (2) Use ohmmeter. Use ohmmeter.
Will not run on external ac or dc source.	Ballast lamp open.	Replace lamp.
Output voltage drifts.	Oven or reference.	(1)
Temperature sensitive.	Oven.	Check oven controller circuit.
Output voltage not correct.	Reference.	Perform calibration procedure.
Output voltages not adjustable to specifications.	Reference.	(1)
Battery won't charge.	Defective battery. Battery charger defective.	Replace. Troubleshoot and repair.
Battery won't charge from external source.	Ballast lamp open.	Replace lamp.
<p>(1) The Reference portion of the Oven/Reference Supply assembly is not field repairable. Refer repair to a Fluke Technical Service Center.</p> <p>(2) Return instrument to Fluke Technical Service Center for service.</p>		

Table 4-3: Internal Measurements*

PCB	TEST POINTS	CORRECT VOLTAGE READING	CORRECTIVE ACTION
A3	TP3, TP4	$\leq 60V$ dc	AC line voltage, Rectifier, Power Transformer
A3	TP6, TP4	32V dc	Pre-Regulator
A3	TP2, TP1	$\leq 31V$ dc	Battery Charger**
A3	TP5, TP1	33.0V dc	Battery Charger**
A4	TP1, TP3	32V dc	Pre-Regulator, Motherboard
A4	TP1, TP2	$\approx 18.5V$ dc	Regulator
Front Panel	10V, COM	10.00000V dc	Oven, Reference Supply
Front Panel	1V, COM	1.000000V dc	Output Divider***
Front Panel	1.018V, COM	1.018000V dc	Output Divider***
Rear Panel	EXT. PWR.	$\geq 24V$ dc	Battery

*Voltage measurements taken with Multimeter A, except for those marked with *** in corrective action column.

**Conditions: battery installed, BATTERY OPR switch ON.

***Calibration of 10V output affects calibration of this output.

Section 5

List of Replaceable Parts

TABLE OF CONTENTS

ASSEMBLY NAME	DRAWING NO.	TABLE NO. PAGE	FIGURE NO. PAGE
732A Final Assembly	732A-7201,732T&B	5-1 5-3	5-1 5-6
A1 LED PCB Assembly	732A-4006	5-2 5-10	5-2 5-10
A2 Motherboard PCB Assembly	732A-4005T	5-3 5-11	5-3 5-11
A3 Pre-Regulator PCB Assembly	732A-4003	5-4 5-12	5-4 5-14
A4 Regulator PCB Assembly	732A-4002T	5-5 5-16	5-5 5-17
A5 Reference PCB Assembly	732A-4001	5-6 5-18	5-6 5-21
A6 Battery Module PCB Assembly	732A-4004	5-7 5-22	5-7 5-23
A7 Calibration PCB Assembly	732A-4007	5-8 5-24	5-8 5-24

INTRODUCTION

This section contains the parts list of the 732A DC Reference Standard. Components are listed alphanumerically.

Parts lists include the following information:

1. Reference Designation.
2. Description of each Part.
3. FLUKE Stock Number.
4. Federal Supply Code for Manufacturers.
5. Manufacturer's Part Number.
6. Total Quantity of Components Per Assembly.

Although Fluke recommends module exchange in place of component-level repair, this manual also includes schematics and a discussion of the theory of operation. Service by non-factory personnel voids the warranty. Use of parts not approved by Fluke may compromise board specifications and operation.

HOW TO OBTAIN PARTS

Components may be ordered directly from the John Fluke Mfg. Co., Inc. or its authorized representative by using the Fluke Stock Number or from the manufacturer by using the manufacturer's part number.

In the event the part you order has been replaced by a new or improved part, the replacement will be accompanied by an explanatory note and installation instructions, if necessary.

To ensure prompt handling of your order, include the following information:

1. Quantity.
2. Fluke Stock Number.
3. Description.
4. Reference Designation.
5. Printed Circuit Board Part Number and Revision Letter.

Parts price information is available from the John Fluke Mfg. Co., Inc. or from its representatives.

Table 5-1. 732A Final Assembly

REF DES	DESCRIPTION	FLUKE STOCK NO.	MFG SPLY CODE	MFG PART NO.	TOT QTY	REC QTY	NOTE
FINAL ASSEMBLY, 732A FIGURE 5-1 (732A-7201, 732A T&B)							
A1	LED PCB ASSEMBLY	642280	89536	642280	1		
A2	MOTHER PCB ASSEMBLY				1		1
A3	PRE-REGULATOR PCB ASSEMBLY	642264	89536	642264	1		
A4	REGULATOR PCB ASSEMBLY	642256	89536	642256	1		
A5	REFERENCE PCB ASSEMBLY	644914	89536	642272	1		
A6	BATTERY MODULE ASSEMBLY	651000	89536	651000	1		
A7	CALIBRATION PCB ASSEMBLY	645028	89536	645028	1		
C1	CAP, TA, 82 UF +/-20%, 20V	357392	12954	D82GS2D20M	1		
CR1	DIODE, SI, RECTIFIER	116111	05277	1N4817	1		1
DS1	LAMP, NEON	100347	74276	T2-24-2	1		1
E1-E3	BINDING POST ASSEMBLY, RED	637892	89536	637892	3		
E4	BINDING POST ASSEMBLY, BLK	637900	89536	637900	2		
E5	BINDING POST ASSEMBLY, BLK	637900	89536	637900	REF		
E6	BINDING POST ASSEMBLY, BLUE	637876	89536	637876	1		
E7	BINDING POST ASSEMBLY, GREEN	637868	89536	637868	1		
E8	BINDING POST ASSEMBLY, WHITE	637884	89536	637884	2		
E9	BINDING POST ASSEMBLY, WHITE	637884	89536	637884	REF		
E10	POST, GROUNDING, BRASS	102707	20584	1444	1		
H1	NUT, NYLON, PUSH-IN ROUND HEAD	222414	89536	222414	16		
H2	SCREW, PHP, 6-32 X 1/4	152140	89536	152140	32		
H3	SCREW, RHP, 6-32 X 3/4	114223	89536	114223	4		
H4	SCREW, PHP, 4-40 X 5/16	152116	89536	152116	2		
H5	NUT, HEX, 1/4-28	110619	89536	110619	1		
H6	SCREW, FHP, UNDERCUT, 6-32 X 1/4	320093	89536	320093	8		
H7	SCREW, FHP, 6-32 X 3/8	114363	89536	114363	4		
H8	SCREW, PHP, 6-32 X 1 1/4	159756	89536	159756	4		
H9	SCREW, PHP, 6-32 X 1/2	152173	89536	152173	4		
H10	SCREW, FHP, 8-32 X 5/16	281725	89536	281725	8		
H11	SCREW, FHP, 8-32 X 1/2	114355	89536	114355	2		
H12	SCREW, PHP, THD/FORM, #8 X 1/2	306233	89536	306233	16		
H13	SCREW, PHP, 8-32 X 5/8	114983	89536	114983	4		
H14	SCREW, PHP, 8-32 X 7/16	306159	89536	306159	12		
H15	WASHER, BINDING POST	606293	89536	606293	7		
H16	WASHER,FLT,SS,PASS, OD 0.270, ID 0.146	260471	86928	5710-23-16	2		
H17	WASHER, BINDING POST	644740	89536	644740	2		
H18	WASHER, FLAT	312538	89536	312538	1		
H19	WASHER, SHOULDER, NYLON	485417	89536	485417	2		
H20	NUT, HEX, 6-32	110569	89536	110569	2		
H21	WASHER, SPLIT LOCK, 1/4"	111518	89536	111518	1		
MP1	COVER, GUARD	641969	89536	641969	1		
MP2	COVER, TOP	641936	89536	641936	1		

Table 5-1. 732A Final Assembly (cont)

REF DES	DESCRIPTION	FLUKE STOCK NO.	MFG SPLY CODE	MFG PART NO.	TOT QTY	REC QTY	NOTE
MP3	DECAL, CORNER	659235	89536	659235	2		
MP4	BAIL, INSTRUMENT (NOT SHOWN)	605931	89536	605931	2		
MP5	INSULATION, OVEN, OUTER	654251	89536	654251	4		
MP6	INSULATION, OVEN, INNER	654269	89536	654269	4		
MP7	STRAP, OVEN	644799	89536	644799	1		
MP8	TRIM, SIDE	685206	89536	685206	2		
MP9	BRACKET, HANDLE SUPPORT	632414	89536	632414	2		
MP10	CORDSET, 3 WIRE W/RT ANGLE PLUG	363481	70903	KH8339	1		
MP11	CORNER PLASTIC	656231	89536	656231	4		
MP12	COVER, BOTTOM	641944	89536	641944	1		
MP13	HEATER COVER, BOTTOM	644633	89536	644633	1		
MP14	HEATER COVER, TOP	644625	89536	644625	1		
MP15	ELEMENT, HEATING, PATCH TYPE, 4 X 6	643411	85932	113000-465	2		
MP16	ELEMENT STRIP, HEATING	643387	85932	112000-102	2		
MP17	FOOT, REAR PANEL	657064	89536	657064	4		
MP18	FOOT, SINGLE BAIL TYPE (Dark Umber)	653923	89536	653923	4		
MP19	GUIDE, SNAP-IN PCB CARD, 6 1/2"	326009	23880	1650F	6		
MP20	HANDLE	642314	89536	642314	1		
MP21	HANDLE, STRAP	644880	89536	644880	1		
MP22	HEATER HOLDER, BOTTOM	644773	89536	644773	1		
MP23	HEATER HOLDER, TOP	644658	89536	644658	1		
MP24	HEATER HOLDER, TOP	644666	89536	644666	1		
MP25	HOLE PLUG, 5/16 HOLE	187799	89536	187799	4		
MP26	INSULATOR, CHASSIS	644906	89536	644906	1		
MP27	CORNER ANGLE BRACKET	298166	89536	298166	2		
MP28	BULKHEAD GUARD, FRONT	641985	89536	641985	1		
MP29	OVEN, INSUL, OUTER FRONT-BACK	654277	89536	654277	2		
MP30	OVEN INSUL, INNER FRONT BACK	654285	89536	654285	2		
MP31	INSULATOR, SHEET	650788	89536	650788	4.1		
MP32	INSULATOR, SEMI-CONDUCTOR MOUNTING	508630	55285	7403-09-FR-51	2		
MP33	NAMEPLATE, SERIAL, REAR/PANEL	472795	89536	472795	1		
MP34	PANEL, FRONT	641902	89536	641902	1		
MP35	PANEL, REAR	641910	89536	6419190	1		
MP36	PLATE HEATER, BOTTOM	644617	89536	644617	1		
MP37	PLATE HEATER, TOP	644609	89536	644609	1		
MP38	SENSOR PLATE	644641	89536	644641	2		
MP39	PLUG, BANANA TYPE, 15 AMP	101543	71002	401	2		
MP40	RETAINER HANDLE	579052	89536	579052	2		
MP41	SHIM, HEATER	644781	89536	644781	4		
MP42	SPACER, OVEN	644765	89536	644765	1		
MP43	SPACER, NYLON, 6-32 THRU	643361	89536	643361	4		
MP44	SPACER, NYLON, INSULATED	394262	89536	394262	4		
MP45	TERMINAL STRIP, 2-POSITION	654988	89536	654988	1		
MP46	SIDE TRIM	642298	89536	642298	2		
MP47	TRIM, SIDE INSERT	642306	89536	642306	1		
MP48	BULKHEAD GUARD, REAR	641977	89536	641977	1		
MP49	CAP, BINDING POST, KNURLED	102889	20584	1445	1		
MP50	CHASSIS, GUARD	641951	89536	641951	1		
MP51	CHASSIS, SIDE	641928	89536	641928	2		

Table 5-1. 732A Final Assembly (cont)

REF DES	DESCRIPTION	FLUKE STOCK NO.	MFG SPLY CODE	MFG PART NO.	TOT QTY	REC QTY	NOTE
MP52	CABLE TIE, 4 INCH	172080	06383	SST-1	2		
MP53	SIDE TRIM, ADHESIVE	680850	89536	680850	2		
MP54	TOOL, ALIGNMENT (not shown)	686113	89536	686113	2		
R1	RES, COMP, 2.7 +/-5%, 1W	159376	89536	159376	1		
RT1	THERMISTOR, DISC TYPE W/NEG T/C	644054	89536	644054	2	1	
RV1	VARISTOR, 200 PF, 22V	500777	89536	500777	1	1	
TM1	INSTRUCTION MANUAL, 732A	645051	89536	645051	1		
W3	CABLE ASSEMBLY, DIVIDER-OUT&REF-OUT	644997	89536	644997	1		
W4	CABLE ASSEMBLY, THERMISTOR	651067	89536	651067	1		
	RECOMMENDED SPARE PARTS KIT, 732A	684845	89536	684845			
1	IF REPLACEMENT IS NECESSARY, CONTACT YOUR NEAREST SERVICE CENTER.						

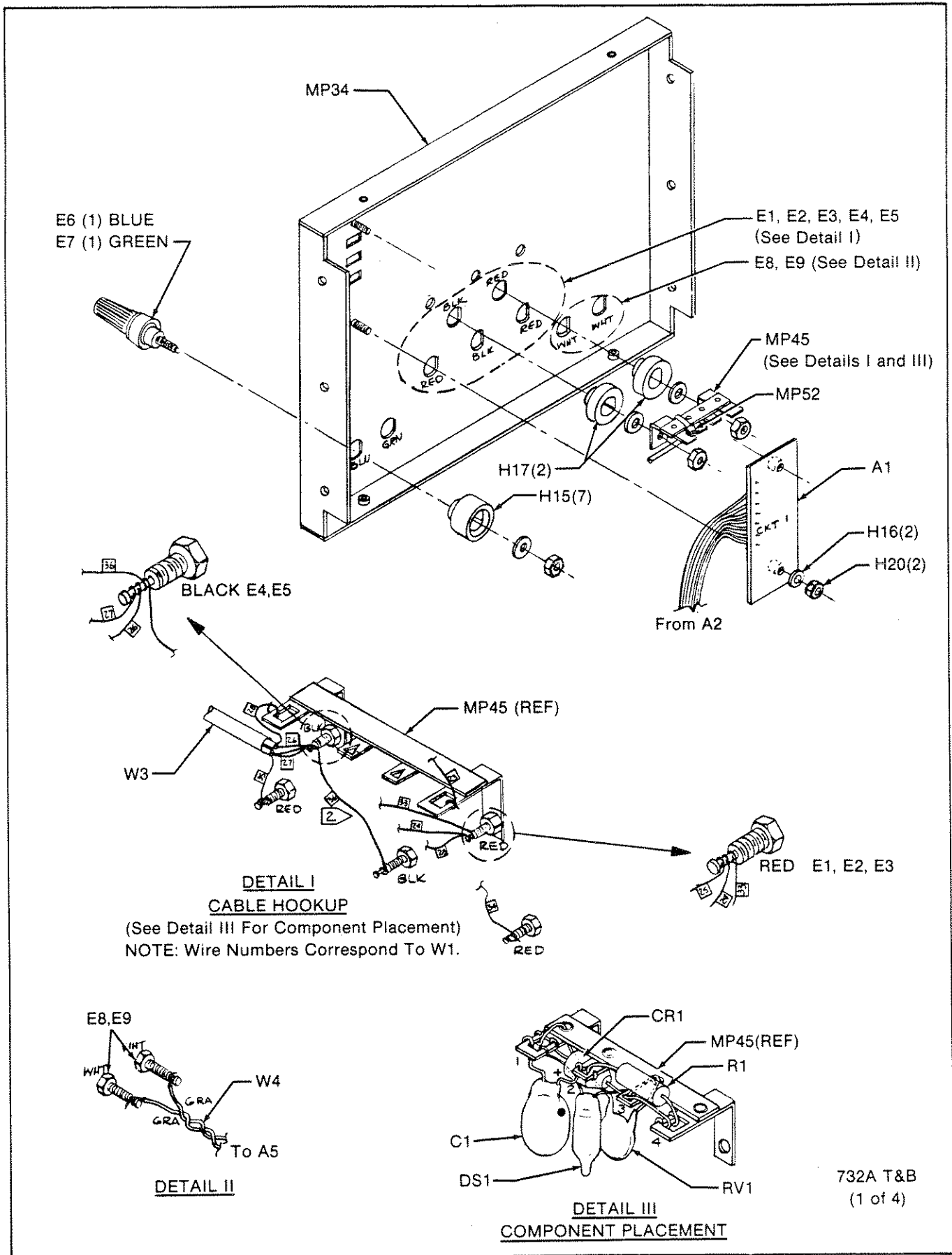

732A T&B
(1 of 4)

Figure 5-1. 732A Final Assembly

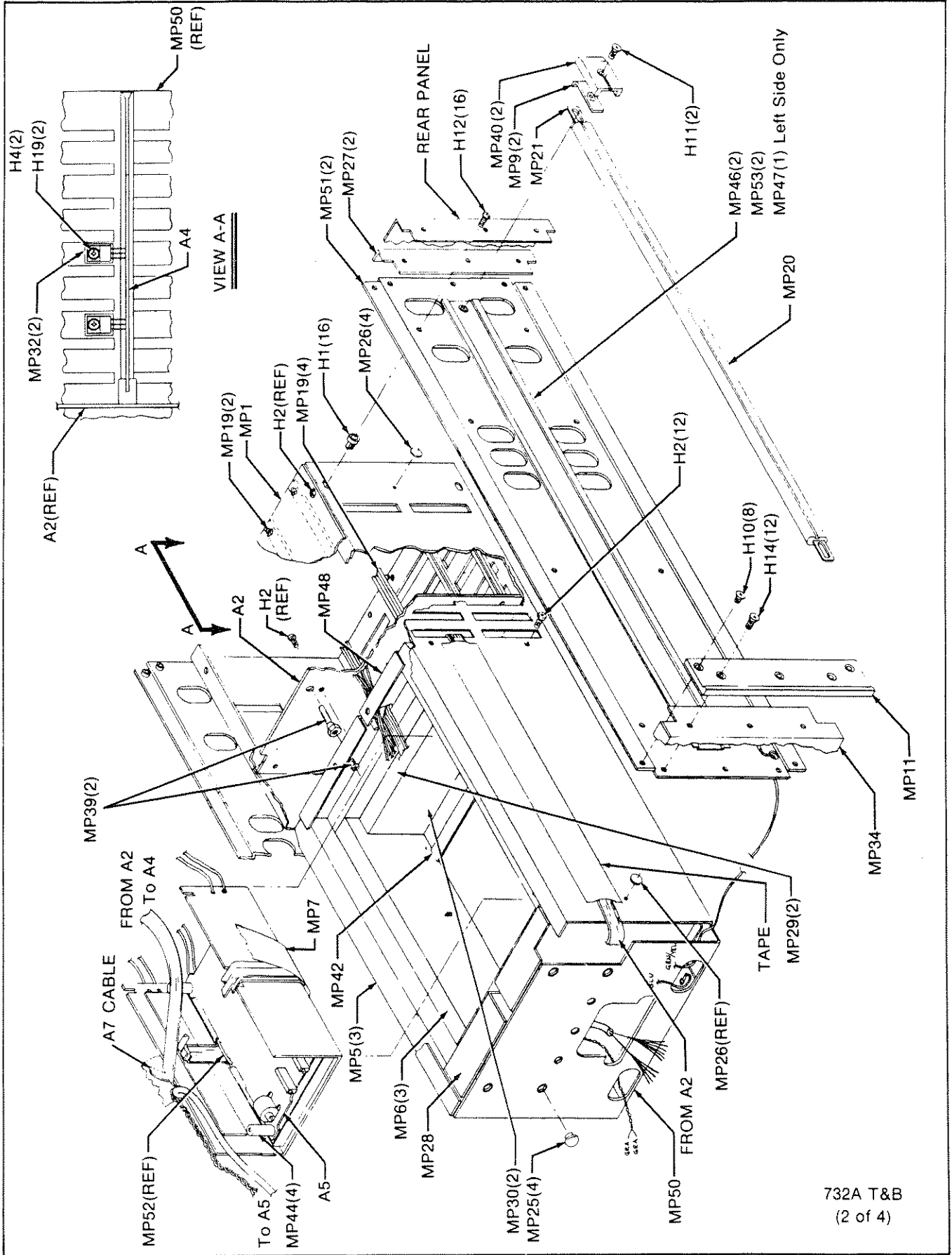

732A T&B
(2 of 4)

Figure 5-1. 732A Final Assembly (cont)

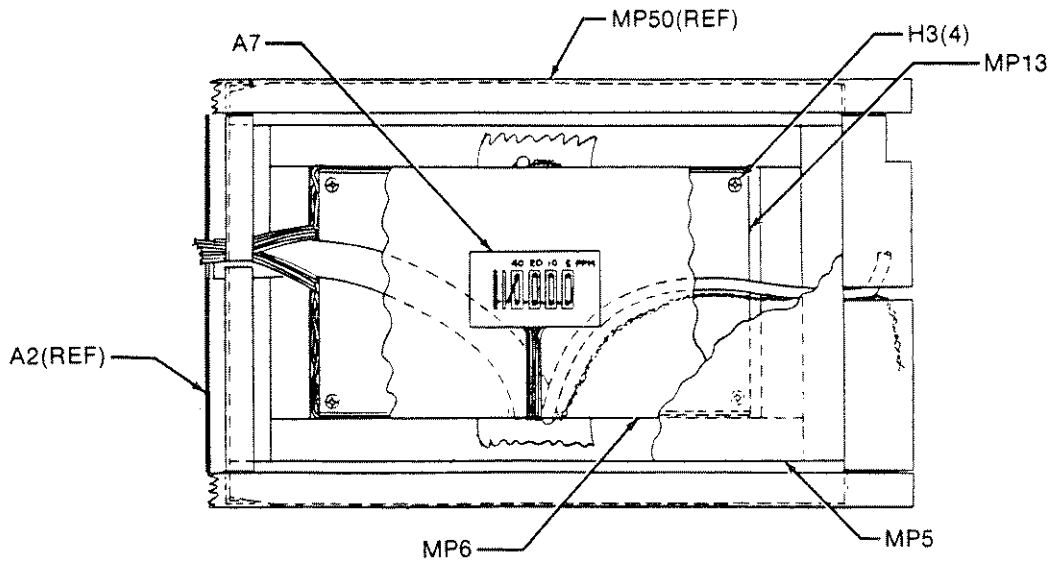

OVEN TOP VIEW

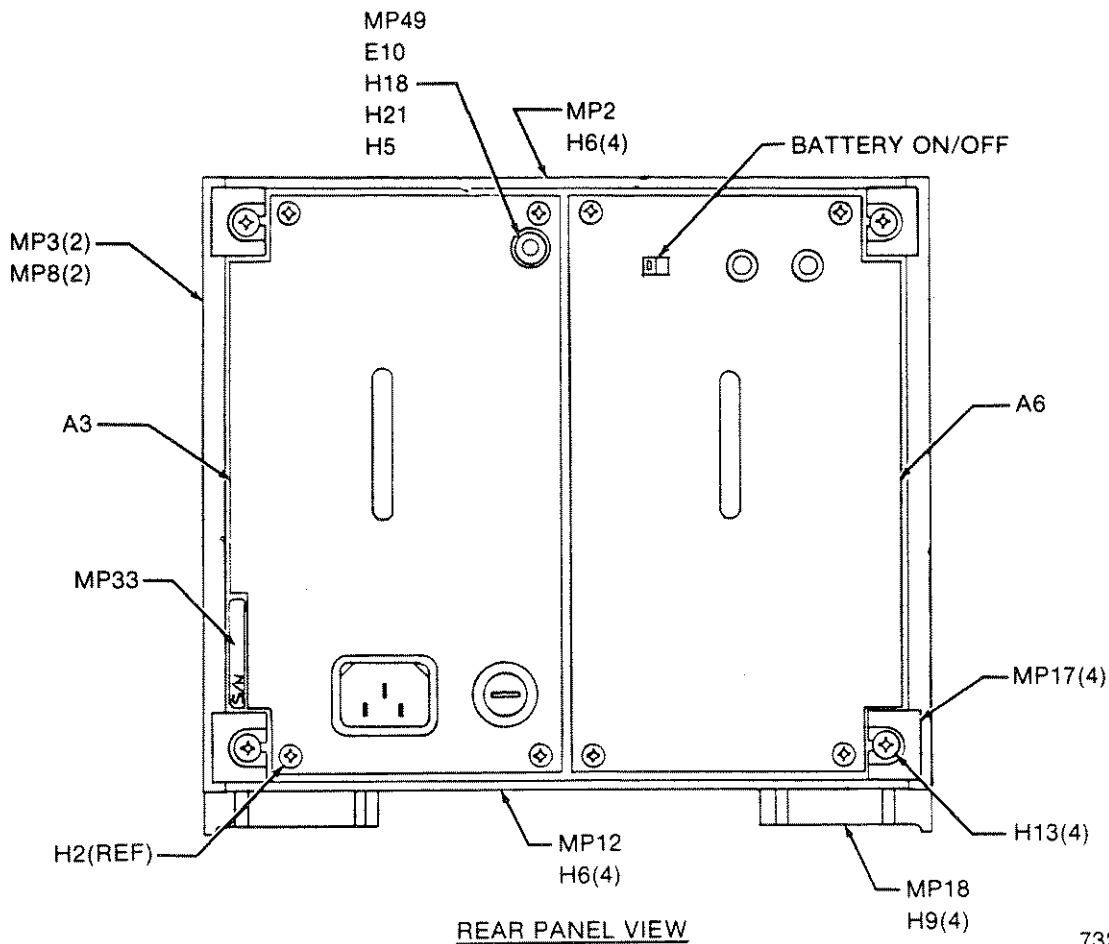

REAR PANEL VIEW

732A T&B
(3 of 4)

Figure 5-1. 732A Final Assembly (cont)

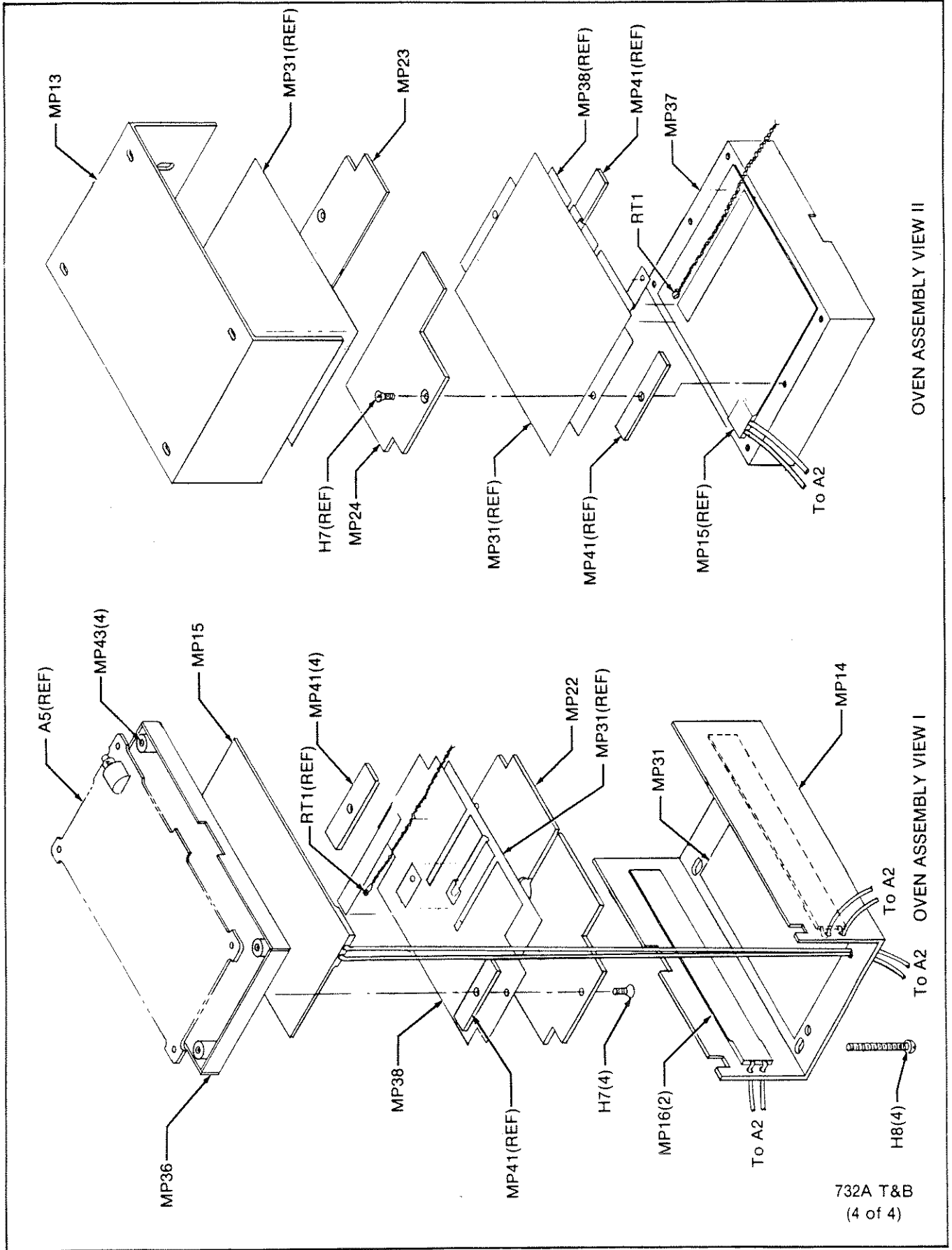

OVEN ASSEMBLY VIEW II

OVEN ASSEMBLY VIEW I

732A T&B
(4 of 4)

Figure 5-1. 732A Final Assembly (cont)

Table 5-2. A1 LED PCB Assembly

REF DES	DESCRIPTION	FLUKE STOCK NO.	MFG SPLY CODE	MFG PART NO.	TOT QTY	REC QTY	NOTE
A1	LED PCB ASSEMBLY FIGURE 5-2 (732A-4006)	642280	89536	642280	REF		
DS1	DIODE, LED, LIGHT BAR MODULE	534834	28480	HLMP 2300	3	1	
DS2	DIODE, LED, LIGHT BAR MODULE	534834	28480	HLMP 2300	REF		
DS3	DIODE, LED, LIGHT BAR MODULE	534834	28480	HLMP 2300	REF		
MP1	STANDOFF, ROUND	357269	89536	357269	2		

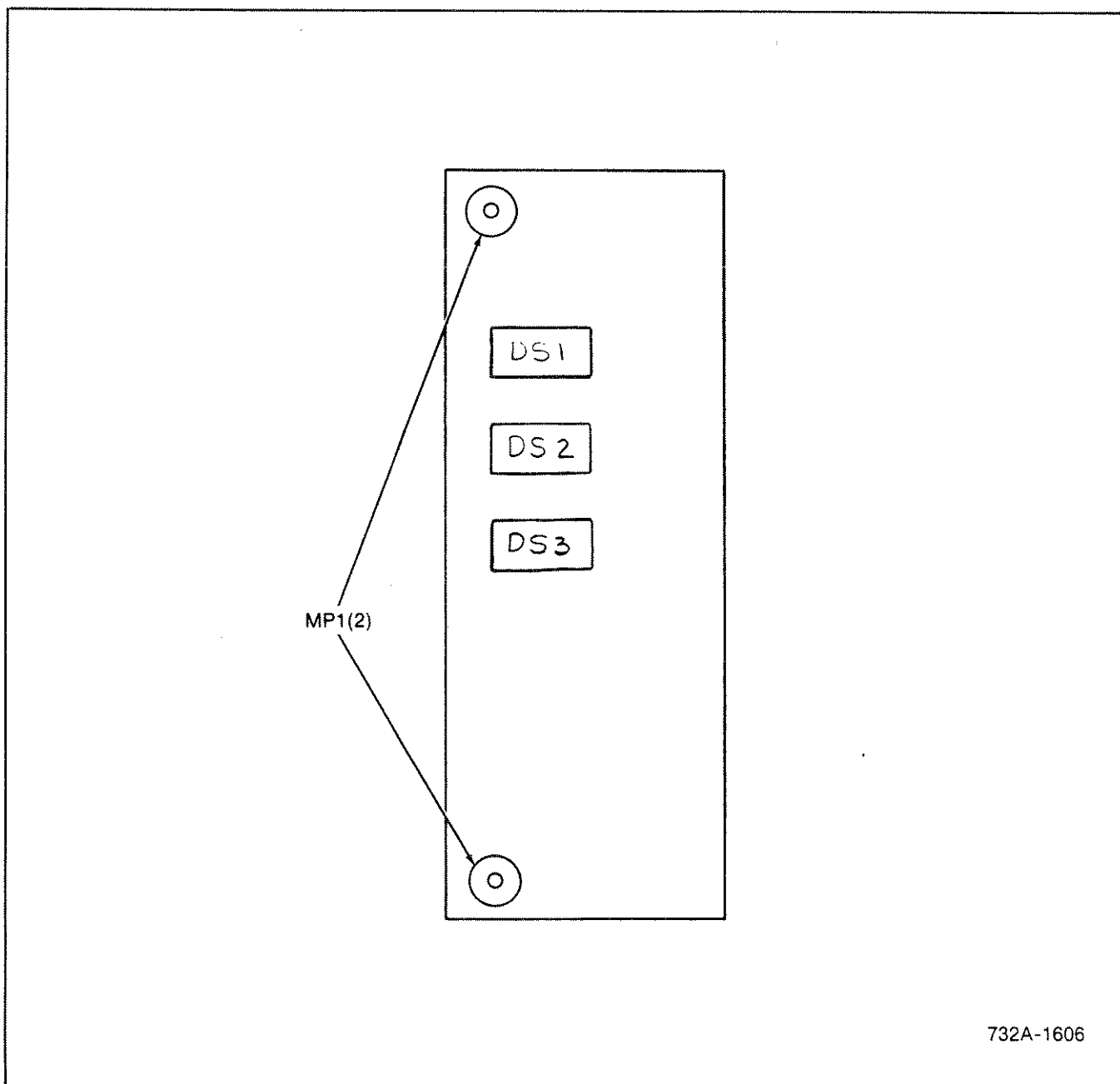

732A-1606

Figure 5-2. A1 LED PCB Assembly

Table 5-3. A2 Motherboard PCB Assembly

REF DES	DESCRIPTION	FLUKE STOCK NO.	MFG SPLY CODE	MFG PART NO.	TOT QTY	REC QTY	NOTE
A2	MOTHER BOARD PCB ASSEMBLY FIGURE 5-3 (732A-4005)	650994	89536	650944	REF		
J2	CONNECTOR, MODULAR (27-POSITIONS)	291708	91662	6308-006-313-001	9		
J3	CONNECTOR, MODULAR (18-POSITIONS)	291708	91662	6308-006-313-001	6		
J4	CONNECTOR, MODULAR (6-POSITIONS)	291708	91662	6308-006-313-001	2		
MP1	KEY, CONNECTOR POLARIZING	291716	89536	291716	8		
TP1	CONNECTOR, TEST POINT	512889	02660	62395	2		
TP2	CONNECTOR, TEST POINT	512889	02660	62395	REF		
W1, W2	CABLE SET ASSEMBLY (not shown)	651059	89536	651059	1		

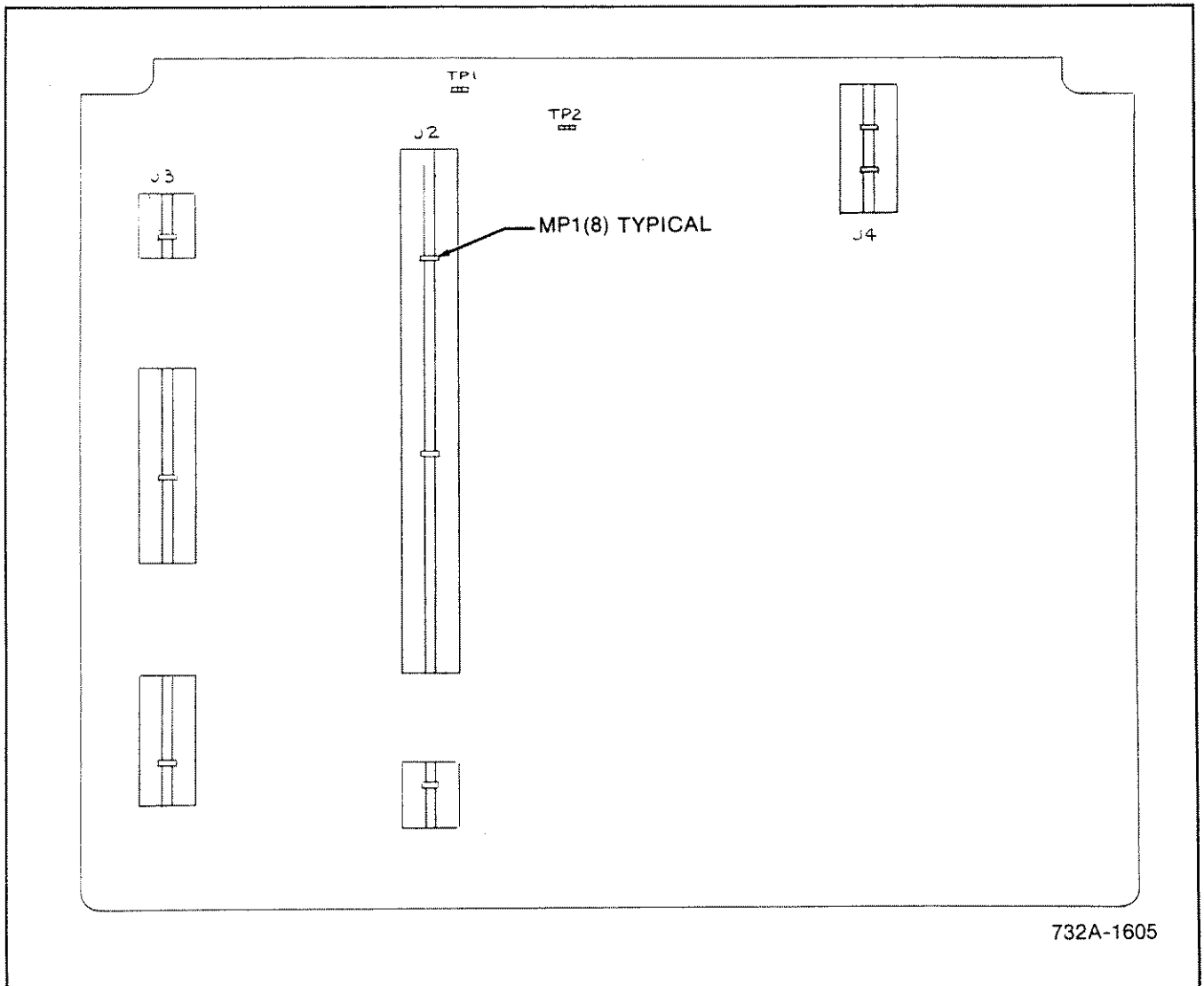

Figure 5-3. A2 Motherboard PCB Assembly

Table 5-4. A3 Pre-Regulator PCB Assembly

REF DES	DESCRIPTION	FLUKE STOCK NO.	MFG SPLY CODE	MFG PART NO.	TOT QTY	REC QTY	NOTE
A3	PRE-REGULATOR PCB ASSEMBLY FIGURE 5-4 (732A-4003)	642264	89536	642264	REF		
C1	CAP, ELECT, 100 UF +75/-20%, 80V	381939	89536	381939	1		
C2	CAP, CER, 0.1 UF +/-20%, 100V	149146	56289	33C41B6	1		
C3	CAP, ELECT, 330 UF -20/+75%, 80V	292862	89536	292862	1		
C4	CAP, CER, 4700 PF +/-20%	362871	72982	8121-A100-W5R-472M	1		
C5	CAP, TA, 1 UF +/-20%, 35V	161919	56289	196D010X0035G	1		
C6	CAP, CER, 0.01 UF +/-20%, 100V	407361	72982	8121-A100-W5R-103M	1		
C9	CAP, CER, 0.05 +/-20%, 50V	149161	56289	55C23A1	2		
C10	CAP, CER, 0.05 +/-20%, 50V	149161	56289	55C23A1	REF		
CR1	RECTIFIER BRIDGE	296509	09423	FB200	1	1	
CR2	DIODE, SI, RECTIFIER	116111	05277	1N4817	4	1	
CR3	DIODE, SI, RECTIFIER	116111	05277	1N4817	REF		
CR4	DIODE, ZEN, UNCOMP, 40V, +/-5%, 1W	407825	12969	UZ8740	1	1	
CR5-CR9	DIODE, SI, HI-SPEED SWITCHING	203323	07910	1N4448	8	2	
CR10	DIODE, ZEN, UNCOMP, +/-10%, 30.0V, 400MW	272633	04713	1N972A	1	1	
CR11	DIODE, SI, HI-SPEED SWITCHING	203323	07910	1N4448	REF		
CR12	DIODE, ZEN, UNCOMP, +/-15%, 5.2V, 4W	233627	89536	233627	2	1	
CR13	DIODE, SI, RECTIFIER	116111	05277	1N4817	REF		
CR14	DIODE, ZEN, UNCOMP, +/-15%, 5.2V, 4W	233627	89536	233627	REF		
CR15	DIODE, ZEN, UNCOMP, +/-5%, 5.6V, 3MA	535559	89536	535559	1	1	
CR16	DIODE, SI, HI-SPEED SWITCHING	203323	07910	1N4448	REF		
CR17	DIODE, SI, HI-SPEED SWITCHING	203323	07910	1N4448	REF		
CR18	DIODE, GE, 80 MA, 100 PIV	149187	93332	1N270	1	1	
CR19	DIODE, SI, RECTIFIER	116111	05277	1N4817	REF		
CR20	DIODE, FED, CURRENT REGULATOR	334839	89536	339839	3	1	
CR21	DIODE, FED, CURRENT REGULATOR	334839	89536	339839	REF		
CR22	DIODE, FED, CURRENT REGULATOR	334839	89536	339839	REF		
CR24	DIODE, FED, CURRENT REGULATOR	429373	89536	429373	1	1	
CR25	DIODE, FED, CURRENT REGULATOR	334714	89536	334714	2	1	
CR26	DIODE, FED, CURRENT REGULATOR	334714	89536	334714	REF		
CR28	DIODE, FED, CURRENT REGULATOR	393454	89536	393454	1	1	
DS1	DIODE, LIGHT EMITTING	369777	89536	369777	1	1	
F1	FUSE, SLO-BLO, 3/8 AMP	109264	89536	109264	1	5	
FL1	FILTER, LINE 250VAC, 50-400HZ, 1 AMP	649988	89536	649988	1		
H1	SCREW, PHP, 4-40 X 5/16	152116	89536	152116	2		
H2	SCREW, PHP, 6-32 X 5/16	152157	89536	152157	4		
H3	WASHER, SHOULDER, #4	485417	89536	485417	2		
H11	NUT, NYLON	222406	89536	222406	4		
H12	NUT, HEX, 4-40	110635	89536	110635	2		
H13	SCREW, THREAD FORMING	574673	89536	574673	4		
H14	SCREW, PHP, 6-32 X 3/8	152165	89536	152165	2		
H15	SCREW, PHP, 6-32 X 5/16	152157	89536	152157	2		
H16	SCREW, PHP, 8-32 X 1/4	228890	89536	228890	2		
H17	WASHER, FLAT PLASTIC, #8	197426	89536	197426	2		
H18	WASHER, FLAT, STEEL, ID 0.125	146225	89536	146225	2		
MP1	INSULATOR, SEMI-CONDUCTOR MOUNTING	508630	55285	7403-09-FR-51	2		
MP2	HEAT SINK	644062	89536	644062	1		
MP3	HEAT SINK	644674	89536	644674	1		

Table 5-4. A3 Pre-Regulator PCB Assembly (cont)

REF DES	DESCRIPTION	FLUKE STOCK NO.	MFG SPLY CODE	MFG PART NO.	TOT QTY	REC QTY	NO TE
MP11	BRACKET, PRE-REGULATOR	641993	89536	641993	1		
MP12	HANDLE, BLACK ALUMINUM	650242	89536	650242	1		
MP13	LUG, SOLDER, 1-1/4" LONG	101030	79963	174	1		
MP14	PANEL, PRE-REGULATOR	644583	89536	644583	1		
Q1	TRANSISTOR, SI, NPN	386128	01295	T1P120	1	1	
Q2	TRANSISTOR, SI, PNP	642694	04713	2N6125	1	1	
Q3	TRANSISTOR, POWER	454033	07263	FT317	1	1	
Q4	TRANSISTOR, SI, NPN, SMALL SIGNAL	242065	04713	2N5089	1	1	
Q5	TRANSISTOR, SI, PNP	195974	04713	2N3906	1	1	
Q6	TRANSISTOR, SI, NPN	168716	04713	2N2484	1	1	
R1	RES, WW, 10M +/-0.5%, 1/2W	212191	89536	212191	1		
R3	RES, COMP, 3.3 +/-5%, 1/2W	188482	01221	EB3R35	1		
R4	RES, MTL. FILM, 1.54K +/-1%, 1/8W	335331	91637	CMF551541F	1		
R6	RES, COMP, 510 +/-5%, 1/4W	218032	01121	CB5115	1		
R7	RES, MTL. FILM, 22.6 +/-1%, 1/8W	296640	91637	CMF5522R6F	1		
R8	RES, MTL. FILM, 402 +/-1%, 1/8W	289611	91637	CMF554020F	1		
R9	RES, COMP, 10K +/-5%, 1/2W	109165	01121	EB1035	1		
R10	RES, VAR, 500 +/-20%, 1/2W	267849	11236	190PC501B	1		
R11	RES, MTL. FILM, 12.7K +/-1%, 1/8W	294918	91637	CMF551272F	1		
R12	RES, MTL. FILM, 16.2K +/-1%, 1/8W	226233	91637	CMF551622F	1		
R13	RES, MTL. FILM, 33.2K +/-0.5%, 1/8W	334102	91637	CMF553322B	1		
R14	RES, MTL. FILM, 17.4K +/-1%, 1/8W	349175	91637	CMF551742F	1		
R15	RES, COMP, 10K +/-5%, 1/4W	148106	01121	CB1035	2		
R16	RES, COMP, 10K +/-5%, 1/4W	148106	01121	CB1035	REF		
R17	RES, MTL. FILM, 6.49K +/-1%, 1/8W	294900	91637	CMF556491F	1		
R18	RES, MTL. FILM, 43.2K +/-1%, 1/8W	312223	91637	CMF554322F	1		
R20	RES, VAR, 50K +/-10%, 1/2W	330688	11236	190PC503B	1		
RT1	THERMISTOR, TEMPERATURE SENSITIVE	104596	73168	JA41J1	1	1	
S1	SWITCH, SLIDE, DPDT	234278	89536	234278	2	1	
S2	SWITCH, SLIDE, DPDT	234278	89536	234278	REF		
T1	TRANSFORMER, POWER	645036	89536	645036	1		
TP1-TP6	CONNECTOR, TEST POINT	512889	02660	62395	6		
W1	WIRE, JUMPER, #22	529271	89536	529271	1		
XF1	FUSEHOLDER, BODY & CAP	424416	89536	424416	1		

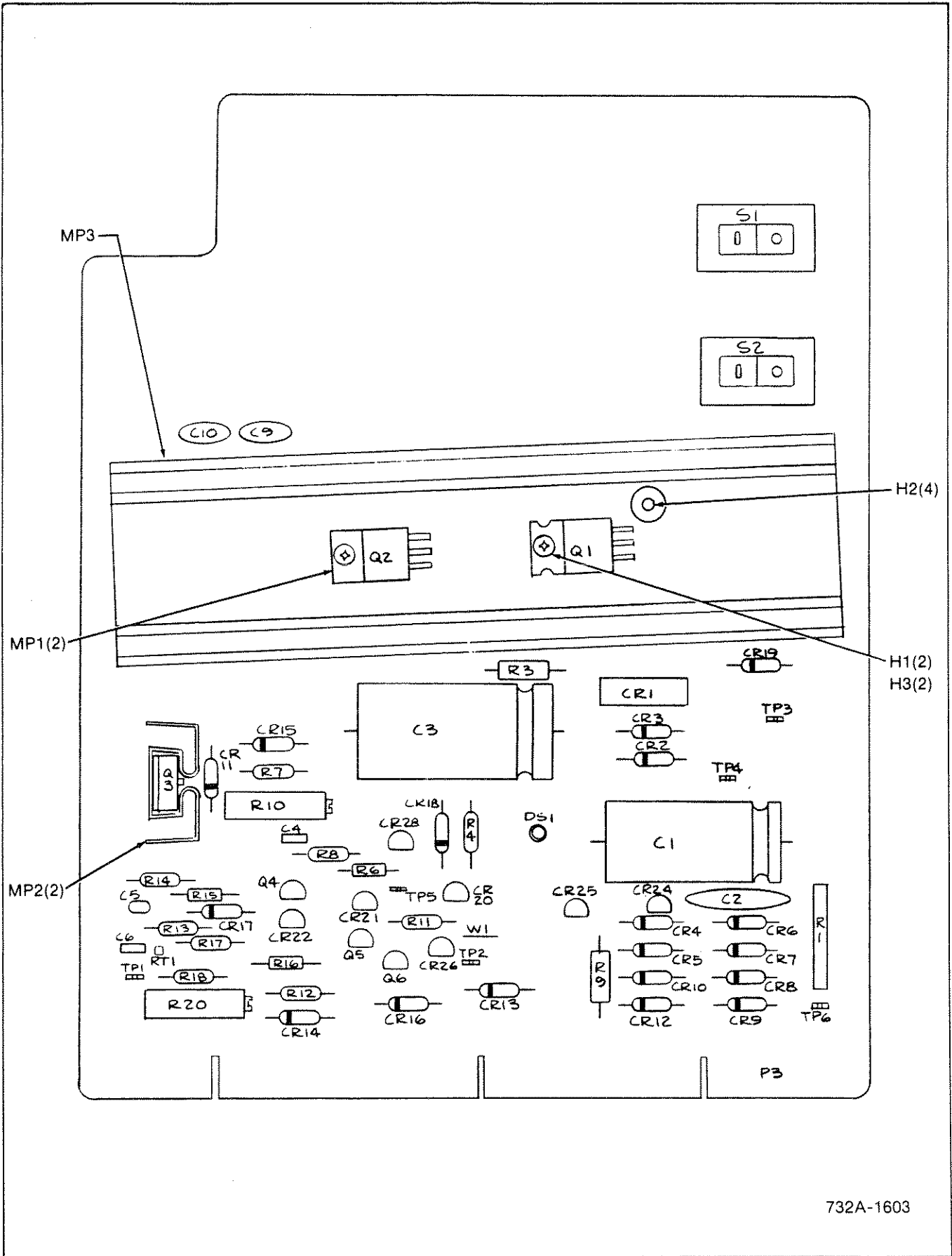

732A-1603

Figure 5-4. A3 Pre-Regulator PCB Assembly

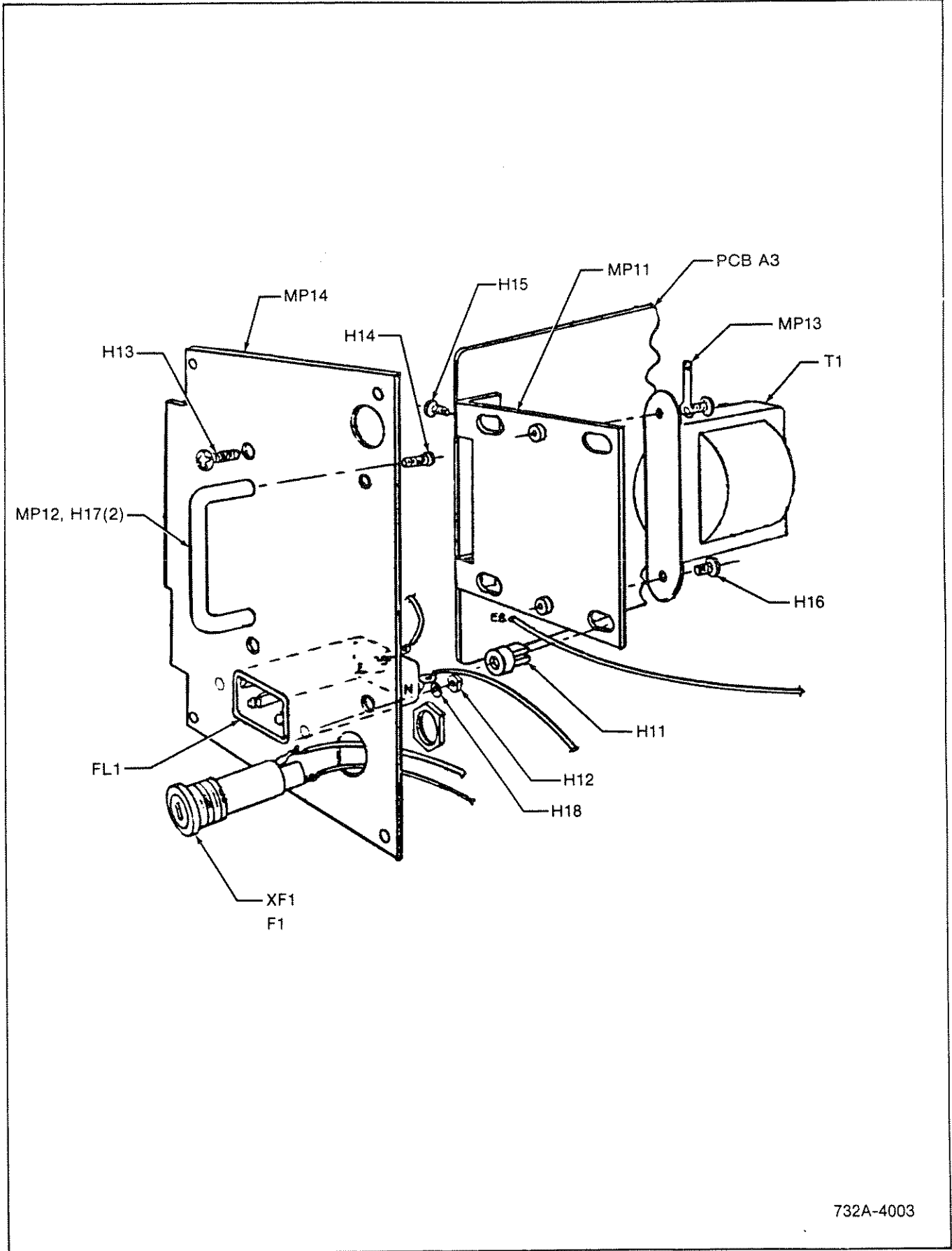

732A-4003

Figure 5-4. A3 Pre-Regulator PCB Assembly (cont)

Table 5-5. A4 Regulator PCB Assembly

REF DES	DESCRIPTION	FLUKE STOCK NO.	MFG SPLY CODE	MFG PART NO.	TOT QTY	REC QTY	NOTE
A4	REGULATOR PCB ASSEMBLY FIGURE 5-5 (732A-4002)	642256	89536	642256	REF		
C1	CAP, ELECT, 330 UF +/-20%, 80V	292862	89536	292862	1		
C2	CAP, TA, 82 UF +/-20%, 20V	357392	12954	D82GS2D20M	1		
C3, C4	CAP, TA, 10 UF +/-20%, 35V	417683	56289	196D106X0035KA1	2		
C5	CAP, CER, 0.22 UF +/-20%, 25V	309849	71590	CW3COC224K	3		
C6	CAP, CER, 0.047 UF +/-20%, 50V	460733	71590	CW20C473M	1		
C7	CAP, CER, 0.01 UF -20/+100%, 40V	369579	51406	8121-A050-651-103Z	1		
C8	CAP, CER, 0.22 UF +/-20%, 25V	309849	71590	CW3COC224K	REF		
C9	CAP, TA, 22 UF +/-20%, 25V	357780	56289	196D226X0035TE4	1		
C10	CAP, CER, 0.22 UF +/-20%, 50V	309849	71590	CW3COC224K	REF		
CR1	DIODE, ZEN, UNCOMP,	473744	07910	1N5240	2	1	
CR3	DIODE, SI, HI-SPEED SWITCHING	203323	07910	1N4448	3	1	
CR4	DIODE, ZEN, COMP, +/-5%, 6.4V, 1 MA	330829	07910	1N4571	1	1	
CR5	DIODE, SI, HI-SPEED SWITCHING	203323	07910	1N4448	REF		
CR6	DIODE, SI, HI-SPEED SWITCHING	203323	07910	1N4448	REF		
CR7	DIODE, GE, 80 MA, 100PIV	149187	93332	1N270	2	1	
CR8	DIODE, GE, 80 MA, 100PIV	149187	93332	1N270	REF		
CR9	DIODE, ZEN, UNCOMP,	473744	07910	1N5240	REF		
CR10	DIODE, FED, CURRENT REGULATOR	393454	07910	TCR5290	1	1	
CR12	DIODE, FED, CURRENT REGULATOR	334839	11532	TCR5297	2	1	
CR13	DIODE, FED, CURRENT REGULATOR	348482	89536	348482	1		
CR14	DIODE, FED, CURRENT REGULATOR	334839	11532	TCR5297	REF		
CR15	DIODE, SI, RECTIFIER	116111	05277	1N4817	1	1	
DS1	DIODE, LED, VISIBLE RED	369777	28480	5082-4480	1	1	
Q1	TRANSISTOR, SI, PNP	229898	04713	MPS6522	2	1	
Q2	TRANSISTOR, SI, PNP	218388	07236	2N3645	1	1	
Q3	TRANSISTOR, SI, NPN, SMALL SIGNAL	352138	89536	352138	2	1	
Q4	TRANSISTOR, POWER	454033	07263	FT317	1	1	
Q5	TRANSISTOR, SI, PNP	229898	04713	MPS6522	REF		
Q6	TRANSISTOR, SI, NPN	218396	04713	2N3904	1	1	
Q7	TRANSISTOR, SI, PROGRAMMABLE UNIJUNCTION	268110	03508	2N6027	1	1	
Q8	TRANSISTOR, SI, NPN, SMALL SIGNAL	352138	89536	352138	REF		
Q12	TRANSISTOR, SI, PNP	195974	04713	2N3906	2	1	
Q13	TRANSISTOR, SI, PNP	195974	04713	2N3906	REF		
Q14	TRANSISTOR, SI, PNP	642694	89536	642694	1	1	
R1	RES, MTL. FILM, 348 +/-1%, 1/8W	236778	91637	CMF553480F	1		
R2	RES, MTL. FILM, 1.21K +/-1%, 1/8W	229146	91637	CMF551211F	1		
R3	RES, MTL. FILM, 24.3 +/-1%, 1/8W	281816	91637	CMF5524R3F	1		
R4	RES, MTL. FILM, 8.66K +/-1%, 1/8W, T9	330738	91637	CMF558661F	1		
R5	RES, COMP, 3K +/-5%, 1/4W	193508	01121	CB3025	1		
R6	RES, COMP, 4.3K +/-5%, 1/4W	193375	01121	CB4325	1		
R7	RES, COMP, 18K +/-5%, 1/4W	148122	01121	CB1835	1		
R8	RES, COMP, 91K +/-5%, 1/4W	193300	01121	CB9135	2		
R9	RES, COMP, 91K +/-5%, 1/4W	193300	01121	CB9135	REF		
R10	RES, MTL. FILM, 5K +/-0.1%, 1/8W	340240	91637	CMF555001B	1		
R11	RES, COMP, 10K +/-5%, 1/4W	148106	01121	CB1035	1		
R12	RES, WW, 0.39 +/-5%, 2W	219386	89536	219386	1		
R13	RES, COMP, 2.7 +/-5%, 1W	159376	01121	GB2R75	1		

Table 5-5. A4 Regulator PCB Assembly (cont)

REF DES	DESCRIPTION	FLUKE STOCK NO.	MFG SPLY CODE	MFG PART NO.	TOT QTY	REC QTY	NOTE
R14	RES, COMP, 150K +/-5%, 1/4W	182212	01121	CB1545	1		
R15	RES, COMP, 51K +/-5%, 1/4W	193334	01121	CB5135	2		
R16	RES, COMP, 1M +/-5%, 1/4W	182204	01121	CB1055	1		
R17	RES, COMP, 2.7K +/-5%, 1/4W	170720	01121	CB2725	1		
R18	RES, COMP, 16K +/-5%, 1/2W	159632	01121	EB1635	1		
R19	RES, COMP, 18K +/-5%, 1/2W	187898	01121	EB1835	1		
R20	RES, COMP, 8.2K +/-5%, 1/4W	160796	01121	CB8225	1		
R21	RES, COMP, 1K +/-5%, 1/4W	148023	01121	CB1025	1		
R22	RES, VAR, CERMET, 5K +/-20%, 3/4W	159905	32997	3059Y-1-502	1		
R23	RES, COMP, 270K +/-5%, 1/4W	220061	01121	CB2745	1		
R24	RES, DEP. CAR, 1K +/-5%, 1/4W	343426	80031	CR251-4-5P1K	1		
R25	RES, COMP, 51K +/-5%, 1/4W	193334	01121	CB5135	REF		
R26	RES, COMP, 10 +/-5%, 1/4W	147868	01121	CB1005	1		
TP1-TP3	CONNECTOR, TEST POINT	512889	02660	62395	3		

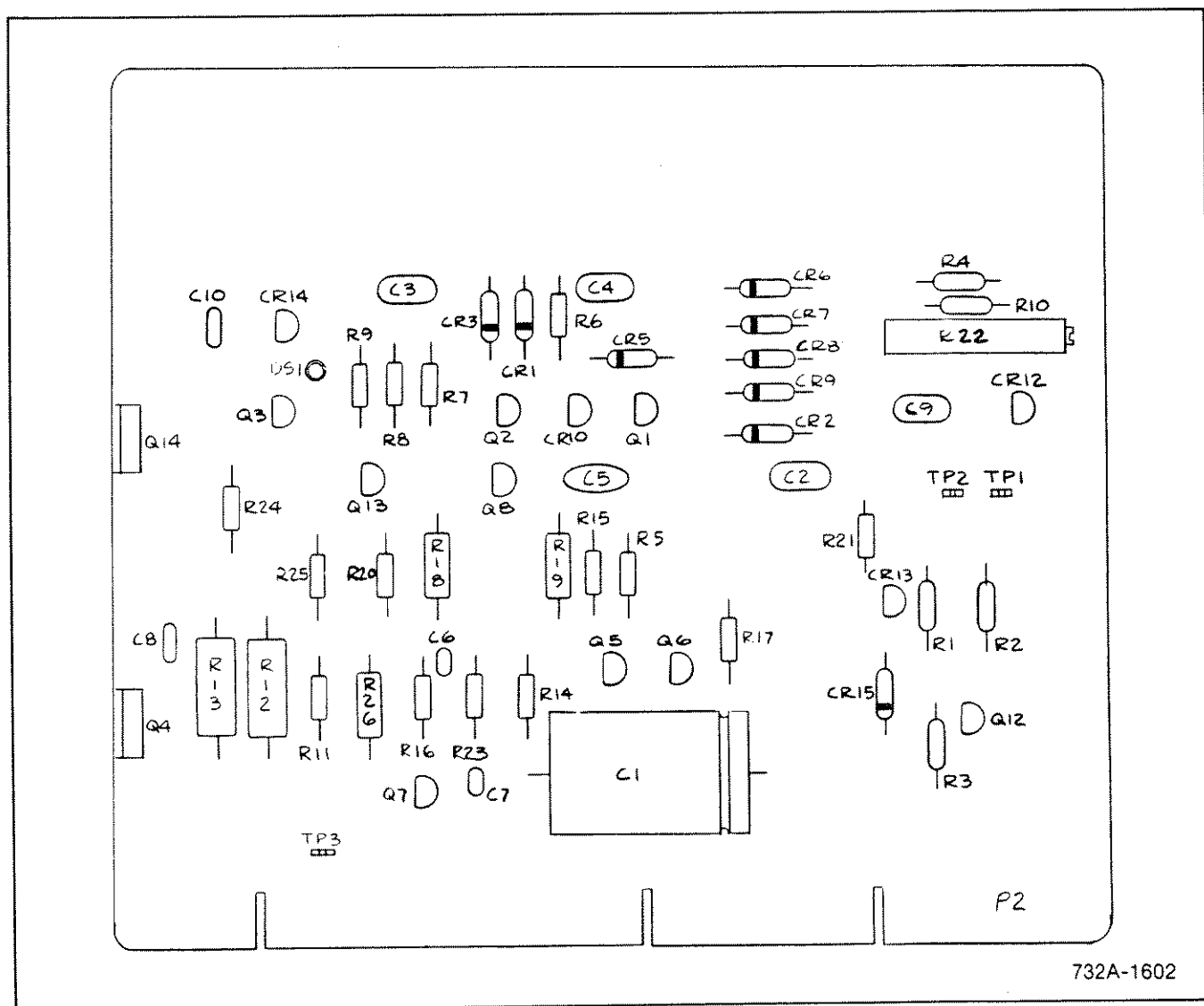

Figure 5-5. A4 Regulator PCB Assembly

Table 5-6. A5 Reference PCB Assembly

REF DES	DESCRIPTION	FLUKE STOCK NO.	MFG SPLY CODE	MFG PART NO.	TOT QTY	REC QTY	NOTE
A5	REFERENCE PCB ASSEMBLY (732A-7601K) FIGURE 5-6 (732A-4001)	644914	89536	642272	REF		
C1	CAP, CER, 0.22 UF +/-20%, 50V	309849	71590	CW3COC224K	5		
C2*	CAP, CER, 0.22 UF +/-20%, 50V	309849	71590	CW3COC224K	REF		
C3*	CAP, POLY, 1 UF +/-10%, 50V	271619	84411	X463UW1029,50W	1		
C4*	CAP, CER, 330 PF, 100V	528620	89536	528620	1		
C5	CAP, CER, 0.22 UF +/-20%, 50V	309849	71590	CW3COC224K	REF		
C6	CAP, CER, 0.22 UF +/-20%, 50V	309849	71590	CW3COC224K	REF		
C7	CAP, CER, 0.005 UF +/-20%, 50V	255471	51642	200-050-601-502M	1		
C8	CAP, POLY, 5.0 UF +/-10%, 50V	313254	84411	X463UW591W	1		
C9	CAP, POLY, 0.47 UF +/-10%, 100V	288860	84411	X463UW06891W	1		
C10	CAP, POLY, 4 UF +/-20%, 50DCV	340281	84411	X463UW405050	1		
C11	CAP, MICA, 270 PF +/-5%, 500V	148452	14655	CD15FD271J0	1		
C12	CAP, MICA, 100 PF +/-5%, 500V	148494	14655	CD15FD101J0	2		
C13	CAP, MICA, 100 PF +/-5%, 500V	148494	14655	CD15FD101J0	REF		
C14*	CAP, CER, 180 PF +/-10%, 1000V	105890	56289	CO23B102E181M	1		
C15*	CAP, CER, 0.22 UF +/-20%, 50V	309849	71590	CW3COC224K	REF		
C16	CAP, CER, 0.047 UF +/-20%, 50V	460733	71590	CW20C473M	1		
C17*	CAP, CER, 1200 PF +/-20%, 100V	358283	72982	8121-A100-W5R-122M	1		
CR1*	DIODE, ZEN, UNCOMP, 5.2V +/-15%	233627	89536	233627	1	1	
CR2*	DIODE, ZEN, COMP, 6.4V +/-5%	330829	07910	1N4571	1	1	
CR3	DIODE, SI, HI-SPEED SWITCHING	203323	07910	1N4448	3	1	
CR4	DIODE, SI, HI-SPEED SWITCHING	203323	07910	1N4448	REF		
CR5*	DIODE, FED, CURRENT REGULATOR	334839	89536	334839	1	1	
CR6*	DIODE, ZEN, UNCOMP, 12V +/-5%, 1W	276980	12969	UZ8712	2	1	
CR7*	DIODE, SI, HI-SPEED SWITCHING	203323	07910	1N4448	REF		
CR8	DIODE, ZEN, UNCOMP, 12V +/-5%, 1W	276980	12969	UZ8712	REF		
H1	SCREW, SET, 6-32 X 3/4 (not shown)	643395	89536	643395	1		
MP1	COMPONENT STRAP, RUBBER (not shown)	104794	98159	2829-115-3	1		
MP2	HEATSINK, IC (W/U2)	380220	89536	380220	1		
MP3	INSULATOR, TRANSISTOR (not shown)	658807	89536	658807	1		
MP4	SPACER, NYLON (not shown)	643361	89536	643361	1		
MP5	STANDOFF, NYLON (not shown)	394262	89536	394262	1		
MP6	TERMINAL, TEFLON, FEED-THRU, 4 LEAD (not shown)	281865	12615	SL-841-777	3		
Q1, Q2*	TRANSISTOR, SI, NPN	218396	04713	2N3904	2	1	
Q3, Q4	TRANSISTOR, SI, PNP	195974	04713	2N3906	2	1	
Q5*	TRANSISTOR, SI, NPN, DOUBLE DIFF	352138	89536	352138	1		
R1*	RES, DEP. CAR, 200 +/-5%, 1/4W	193482	80031	CR251-4-5P200E	1		
R2, R3*	MATCHED RESISTOR SET	634824	89536	634824	1		
R4*	RES, WW, 1.27K	634915	89536	634915	1		
R5*	REF AMP SET (includes R5, R9 and U2)	645010	89536	645010	1		

Table 5-6. A5 Reference PCB Assembly (cont)

REF DES	DESCRIPTION	FLUKE STOCK NO.	MFG SPLY CODE	MFG PART NO.	TOT QTY	REC QTY	NOTE
R6*	RES, MTL. FILM, 51.1K +/-1%, 1/8W	289553	91637	CMF555112F	2		
R7, R8*	RES, REF. AMP DIVIDER SET	346304	89536	346304	1		
R9*	REF AMP SET (includes R5, R9 and U2)					REF	
R10*	RES, WW, 250 +/-0.6%, 1/2W	238485	89536	238485	6		
R11*	RES, WW, 250 +/-0.6%, 1/2W	238485	89536	238485		REF	
R12*	RES, WW, 20	634840	89536	634840	1		
R13*	RES, WW, 125 +/-0.5%, 1/2W	213934	89536	213934	1		
R14*	RES, WW, 250 +/-0.06%, 1/2W	238485	89536	238485	1		
R15	RES, WW, 500 +/-0.06%, 1/2W	195388	89536	195388	2		
R16*	RES, WW, 1K, 1/2W	131706	89536	131706	2		
R17*	RES, WW, 2K, 1/2W	131714	89536	131714	1		
R18*	RES, WW, 500 +/-0.06%, 1/2W	195388	89536	195388		REF	
R19*	RES, WW, 35 +/-0.5%, 1/4W	634907	89536	634907	5		
R20*	RES, VAR, CERMET, 100 +/-20%, 3/4W	159889	32997	3059Y-1-101	1		
R21	RES, MTL. FILM, 4.553K +/-0.1%, 1/8W	386292	89536	386292	1		
R22	RES, MTL. FILM, 17.4K +/-1%, 1/8W	335372	91637	CMF551742F	1		
R23	RES, COMP, 51 +/-5%, 1/4W	221879	01121	CB5105	3		
R24*	RES, COMP, 10 +/-5%, 1/4W	147868	01121	CB1005	1		
R25*	RES, COMP, 30K +/-5%, 1/4W	193417	01121	CB3035	1		
R26*	RES, COMP, 51 +/-5%, 1/4W	221879	01121	CB5105		REF	
R27	RES, MTL. FILM, 10K +/-0.1%, 1/8W	435065	89536	435065	1		
R28	RES, MTL. FILM, 7.50K +/-1%, 1/8W	484881	91637	CMF557501F	1		
R29	RES, MTL. FILM, 19.1K +/-1%, 1/8W, T9	291518	91637	CMF551912F	1		
R30	RES, MTL. FILM, 2.15K +/-1%, 1/8W	347039	91637	CMF552151F	1		
R31	RES, MTL. FILM, 1K +/-0.1%, 1/8W	340380	89536	340380	1		
R32	RES, COMP, 6.2M +/-5%, 1/4W	221960	01121	CB6255	1		
R33	RES, COMP, 5.1M +/-5%, 1/4W	296467	01121	CB5155	1		
R34	RES, COMP, 2.4M +/-5%, 1/4W	221945	01121	CB2455	1		
R35	RES, COMP, 27M +/-5%, 1/4W	221994	01121	CB2765	2		
R36	RES, COMP, 27M +/-5%, 1/4W	221994	01121	CB2765		REF	
R37	RES, COMP, 1K +/-5%, 1/4W	148023	01121	CB1025	1		
R38	RES, COMP, 51K +/-5%, 1/4W	193334	01121	CB5135	3		
R39	RES, COMP, 51K +/-5%, 1/4W	193334	01121	CB5135		REF	
R40	RES, COMP, 10K +/-5%, 1/4W	148106	01121	CB1035	1		
R41	RES, COMP, 6.8M +/-5%, 1/4W	394064	01121	CB6855	1		
R42	RES, COMP, 51K +/-5%, 1/4W	193334	01121	CB5135		REF	
R43	RES, COMP, 100K +/-5%, 1/4W	148189	01121	CB1045	1		
R44*	RES SET	652784	89536	652784	1		
	(includes R44 and R46)						
R45*	RES SET	652792	89536	652792	1		
	(includes R45 and R47)						
R46*	RES, SET, (includes R44 and R46)					REF	
R47*	RES, SET, (includes R45 and R47)					REF	
R48*	RES, WW, 35 +/-0.5%, 1/4W	634907	89536	634907		REF	
R49*	RES, WW, 35 +/-0.5%, 1/4W	634907	89536	634907		REF	
R50-R53*	RES, WW, 250 +/-0.6%, 1/2W	238485	89536	238485		REF	
R54*	RES, WW, 35 +/-0.5%, 1/4W	634907	89536	634907		REF	
R55*	RES, WW, 35 +/-0.5%, 1/4W	634907	89536	634907		REF	
R56	RES, WW, 1K, 1/2W	131706	89536	131706		REF	
R57*	RES, WW, 350	642801	89536	642801	1		

Table 5-6. A5 Reference PCB Assembly (cont)

REF DES	DESCRIPTION	FLUKE STOCK NO.	MFG SPLY CODE	MFG PART NO.	TOT QTY	REC QTY	NOTE
R58*	RES, VAR, 200 +/-20%, 3/4W	186213	73138	78PR200	1		
R59*	RES, VAR, 10 TURN, 200 +/-3%, 2W	542928	32997	3500-2-201	1		
R60*	RES, MTL. FILM, 51.1K +/-1%, 1/8W	289553	91637	CMF555112F	REF		
R61	RES, COMP, 1M +/-5%, 1/4W	182204	01121	CB1055	1		
R62*	RES, COMP, 2.7 +/-5%, 1/2W	218743	01121	EB2R75	2		
R63*	RES, COMP, 2.7 +/-5%, 1/2W	218743	01121	EB2R75	REF		
R64*	RES, COMP, 51 +/-5%, 1/4W	221879	01121	CB5105	REF		
RT1,RT2	THERMISTOR, TEMPERATURE SENSITIVE	104596	73168	JA41J1	2	1	
TP1-TP14	CONNECTOR, TEST POINT	512889	02660	62395	14		
U1*	IC, LIN, OP-AMP, METAL CAN	288928	12040	LM308AH	1	1	
U2*	REF AMP SET (includes R5, R9 and U2)				REF		
U3	IC, LIN, OP-AMP, DUAL COMPENSATED	473777	12040	LM358N	1	1	
U4	IC, LIN, OP-AMP	284760	12040	LM308H	2	1	
U5	IC, LIN, OP-AMP	284760	12040	LM308H	REF		
	<p>* IF ANY OF THESE COMPONENTS NEED TO BE REPLACED, EITHER RETURN THE INSTRUMENT TO YOUR NEAREST FLUKE SERVICE CENTER FOR REPAIR, OR REPLACE THE ENTIRE REFERENCE PCB ASSEMBLY, PART NO. 644914.</p>						

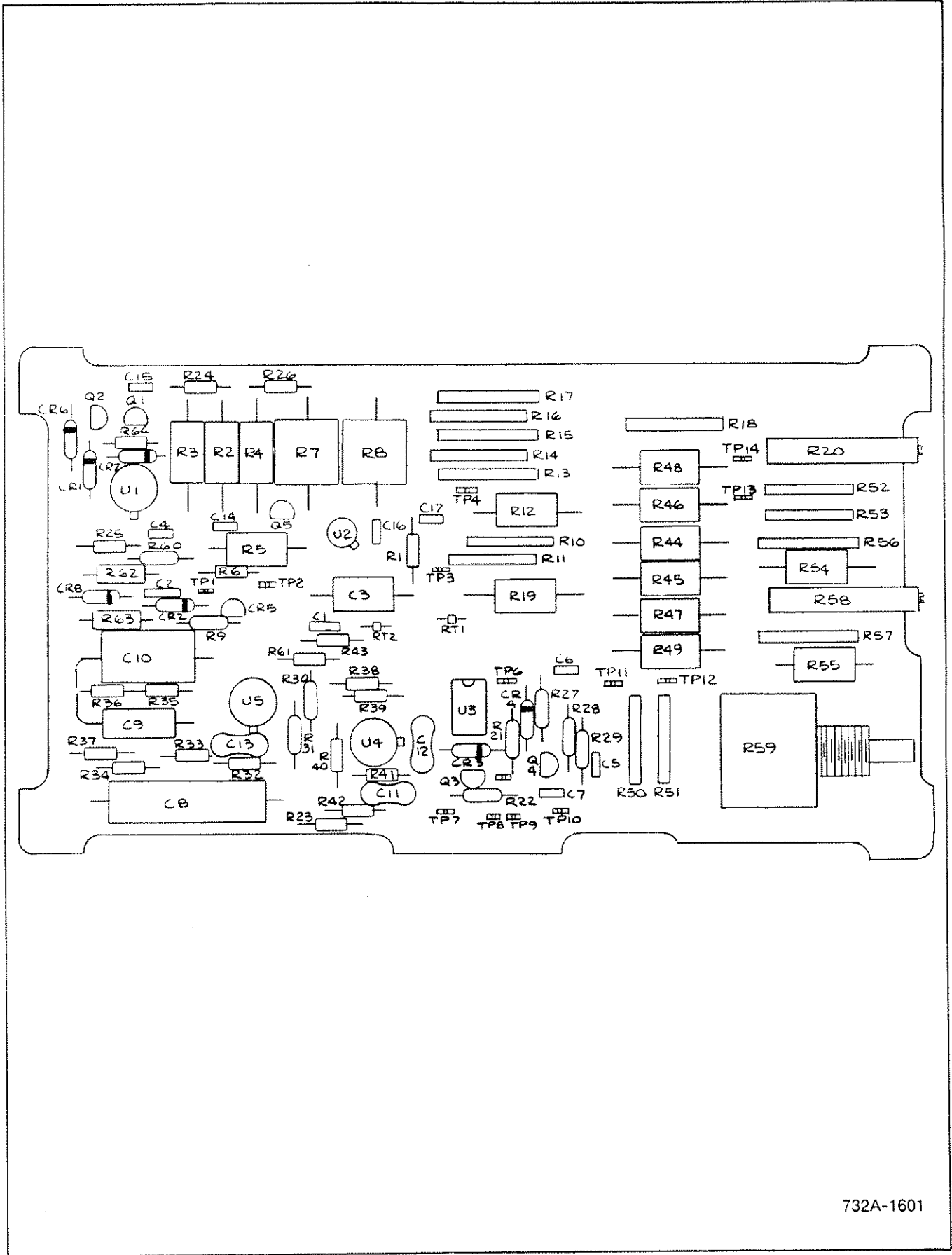

732A-1601

Figure 5-6. A5 Reference PCB Assembly

Table 5-7. A6 Battery Module PCB Assembly

REF DES	DESCRIPTION	FLUKE STOCK NO.	MFG SPLY CODE	MFG PART NO.	TOT QTY	REC QTY	NO TE
A6	BATTERY MODULE PCB ASSEMBLY FIGURE 5-7 (732A-4004)	651000	89536	651000	REF		
BT1-BT4	BATTERY, 6V GEL-CELL	501379	89536	501379	4		
CR1	DIODE, SI, RECTIFIER	116111	05277	1N4817	1	1	
DS1	LAMP, MINIATURE	643346	89536	643346	1	1	
H1	NUT, INSULATOR	279398	89536	279398	4		
H2	SCREW, THREAD FORMING	574673	89536	574673	4		
H3	SCREW, PHP, 4-24 X 3/8	183574	89536	183574	3		
H4	SCREW, PHP, 6-32 X 1/4	152140	89536	152140	12		
H5	SCREW, FHP, UNDERCUT, 6-32 X 1/4	320093	89536	320093	13		
H6	SCREW, PHP, 6-32 X 3/8	152165	89536	152165	2		
H7	WASHER, PLASTIC, #8	197426	89536	197426	2		
J1-J4	CONNECTOR, PCB, HEADER	501759	00779	350209-1	4		
MP1	BATTERY ENCLOSURE, FRONT END	644682	89536	644682	1		
MP2	BATTERY ENCLOSURE, REAR END	644732	89536	644732	1		
MP3	BATTERY ENCLOSURE, TOP	644690	89536	644690	1		
MP4	BATTERY ENCLOSURE, BOTTOM	644708	89536	644708	1		
MP5	BATTERY ENCLOSURE, INBOARD SIDE (not shown)	644716	89536	644716	1		
MP6	BATTERY PANEL, w/SWITCH SWITCH ONLY	644591 309336	89536 89536	644591 309336	1 1		
MP7	BATTERY ENCLOSURE, OUTBOARD SIDE	644724	89536	644724	1		
MP8	JACK, NYLON, BANANA TYPE, RED	162065	74970	108-0902-001	1		
MP9	JACK, NYLON, BANANA TYPE, BLK	162073	74970	108-0903-001	3		
MP10	HANDLE, ALUMINUM, BLACK, 6-32	650242	89536	650242	1		
R1	RES, COMP, 51K +/-5%, 1/4W	193334	01121	CB5135	1		
RT1	THERMISTOR, TEMPERATURE SENSITIVE	104596	73168	JA41J1	2	1	
RT2	THERMISTOR, TEMPERATURE SENSITIVE	104596	73168	JA41J1	REF		
XDS1	HOLDER, COMPONENT	103028	99378	100-200-16-27	2		

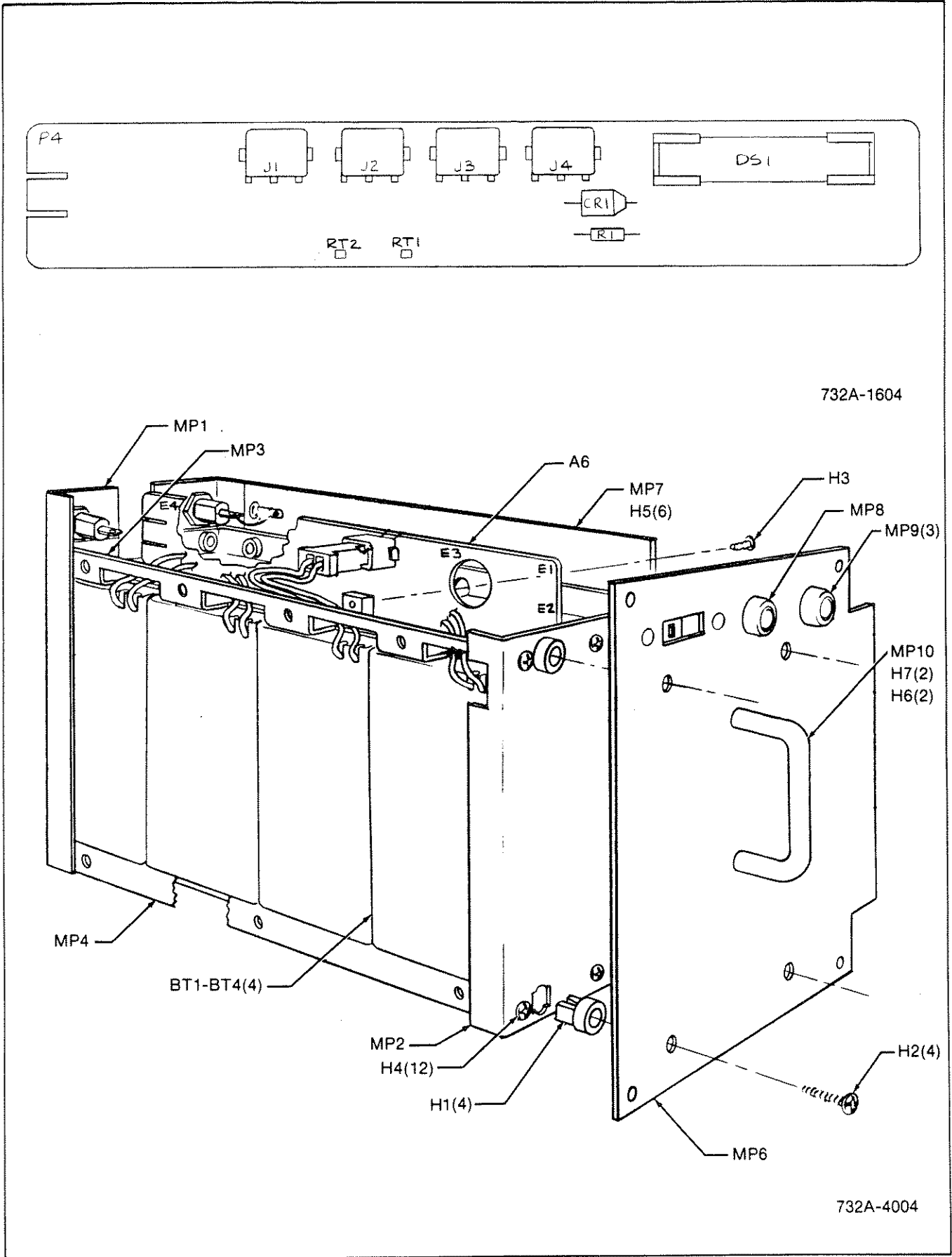

Figure 5-7. A6 Battery Module PCB Assembly

Table 5-8. A7 Calibration PCB Assembly

REF DES	DESCRIPTION	FLUKE STOCK NO.	MFG SPLY CODE	MFG PART NO.	TOT QTY	REC QTY	NOTE
A7	CALIBRATION PCB ASSEMBLY FIGURE 5-8 (732A-4007) includes cable	645028	89536	645028	REF		

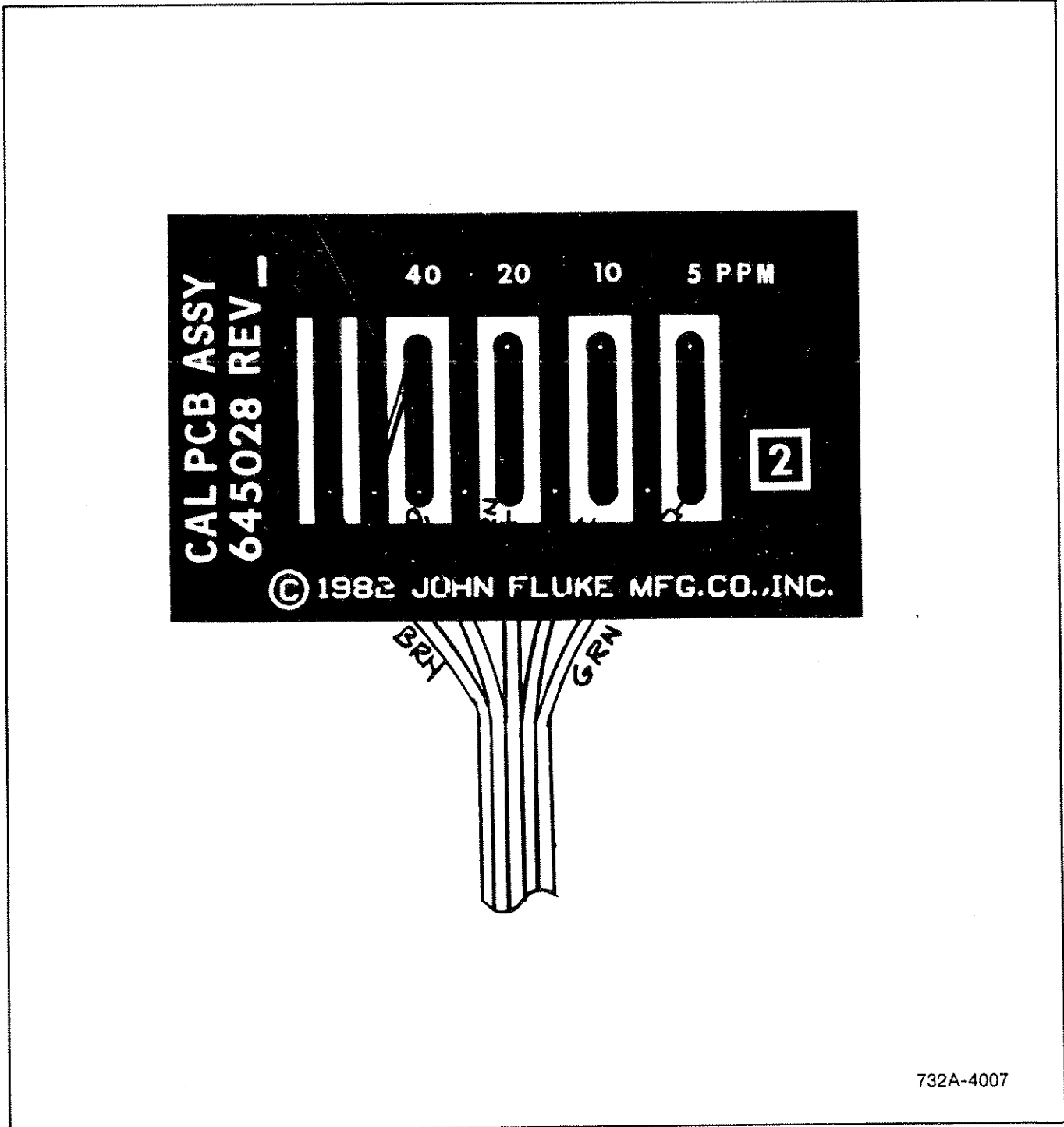

Figure 5-8. A7 Calibration PCB Assembly

Section 6 Accessories

6-1. INTRODUCTION

6-2. This section of the manual describes the accessories available for use with the model 732A.

6-3. DUAL MOUNTING FASTENER (M00-800-523)

6-4. The Dual Mounting Fastener is a 8-32 threaded fastener designed for bolting two half-rack width instruments together. The Dual Mounting Fasteners may be used for either dual rack mounting applications (as used in the M07-200-603 Full-Width Rack Mount Kit) or dual table top applications. Four M00-800-523 fasteners are required for each pair of half-rack width instruments.

6-5. HALF-WIDTH RACK MOUNT KIT (M07-203-601)

6-6. The Half-Width Rack Mounting kit permits the 732A to be rack mounted. A blank filler panel is supplied, allowing left or right hand offset mounting. Assembly instructions are supplied with the kit.

6-7. FULL-WIDTH RACK MOUNT KIT (M07-200-603)

6-8. The Full Width Rack Mounting kit permits the 732A to be rack mounted side-by-side with another half rack width instrument. This rack mounting method requires the 732A to be bolted to the adjacent instrument. To facilitate bolting the instruments together, four M00-

800-523, Dual Mounting Fasteners are included with the kit. Assembly instructions are supplied with the kit.

6-9. LOW THERMAL EMF CABLE ASSEMBLY (5440A-7002)

6-10. The Low Thermal EMF Cable Assembly minimizes the effects of thermal emf errors in test and calibration set-ups. The plugs used are made of the same material as the jacks used in the instrument. Connections between the cables and plugs are carefully made to minimize generation of thermal errors.

6-11. BATTERY PACK (732A-7001)

6-12. The Battery Pack is a replacement module for the rear panel, Battery Module on the 732A. It may be used as an additional auxiliary source, or as a spare.

6-13. TRANSIT CASE (732A-7002)

6-14. The Transit Case provides a means of transporting the 732A while continuously powered by a battery source contained within the Transit Case. This allows continuity of standardization transportation over long distances.

6-15. BATTERY CHARGER (732A-7003)

6-16. The Battery Charger provides the capability to charge up to four battery packs at once. This unit is designed to be used with the transit case for extended battery operation during transit.

1
2
3
4
5
6
7
8
9
10
11
12
13
14
15
16
17
18
19
20
21
22
23
24
25
26
27
28
29
30
31
32
33
34
35
36
37
38
39
40
41
42
43
44
45
46
47
48
49
50
51
52
53
54
55
56
57
58
59
60
61
62
63
64
65
66
67
68
69
70
71
72
73
74
75
76
77
78
79
80
81
82
83
84
85
86
87
88
89
90
91
92
93
94
95
96
97
98
99
100

Section 7

General Information

7-1. This section of the manual contains generalized user information as well as supplemental information to the List of Replaceable Parts contained in Section 5.

List of Abbreviations and Symbols

A or amp	ampere	hf	high frequency	(+) or pos	positive
ac	alternating current	Hz	hertz	pot	potentiometer
af	audio frequency	IC	integrated circuit	p-p	peak-to-peak
a/d	analog-to-digital	if	intermediate frequency	ppm	parts per million
assy	assembly	In	inch(es)	PROM	programmable read-only memory
AWG	american wire gauge	IntI	internal	psi	pound-force per square inch
B	bei	I/O	input/output	RAM	random-access memory
bcd	binary coded decimal	k	kilo (10 ³)	rf	radio frequency
°C	Celsius	kHz	kilohertz	rms	root mean square
cap	capacitor	kΩ	kilohm(s)	ROM	read-only memory
ccw	counterclockwise	kV	kilovolt(s)	s or sec	second (time)
cer	ceramic	lf	low frequency	scope	oscilloscope
cermet	ceramic to metal(seal)	LED	light-emitting diode	SH	shield
ckt	circuit	LSB	least significant bit	Si	silicon
cm	centimeter	LSD	least significant digit	serno	serial number
cmrr	common mode rejection ratio	M	mega (10 ⁶)	sr	shift register
comp	composition	m	milli (10 ⁻³)	Ta	tantalum
cont	continue	mA	milliampere(s)	tb	terminal board
cr	cathode-ray tube	max	maximum	tc	temperature coefficient or temperature compensating
cw	clockwise	mf	metal film	tcxo	temperature compensated crystal oscillator
d/a	digital-to-analog	MHz	megahertz	tp	test point
dac	digital-to-analog converter	min	minimum	u or μ	micro (10 ⁻⁶)
dB	decibel	mm	millimeter	uhf	ultra high frequency
dc	direct current	ms	millisecond	us or μs	microsecond(s) (10 ⁻⁶)
dmm	digital multimeter	MSB	most significant bit	uut	unit under test
dvm	digital voltmeter	MSD	most significant digit	V	volt
elect	electrolytic	MTBF	mean time between failures	v	voltage
ext	external	MTTR	mean time to repair	var	variable
F	farad	mV	millivolt(s)	vco	voltage controlled oscillator
°F	Fahrenheit	mv	multivibrator	vhf	very high frequency
FET	Field-effect transistor	MΩ	megohm(s)	vlf	very low frequency
ff	flip-flop	n	nano (10 ⁻⁹)	W	watt(s)
freq	frequency	na	not applicable	ww	wire wound
FSN	federal stock number	NC	normally closed	xfmr	transformer
g	gram	(-) or neg	negative	xstr	transistor
G	giga (10 ⁹)	NO	normally open	xtal	crystal
gd	guard	ns	nanosecond	xtlo	crystal oscillator
Ge	germanium	opni ampli	operational amplifier	Ω	ohm(s)
GHz	gigahertz	p	pico (10 ⁻¹²)	μ	micro (10 ⁻⁶)
gmv	guaranteed minimum value	para	paragraph		
gnd	ground	pcb	printed circuit board		
H	henry	pF	picofarad		
hd	heavy duty	pn	part number		

Federal Supply Codes for Manufacturers

00213 Nytronics Comp. Group Inc. Subsidiary of Nytronics Inc. Formerly Sage Electronics Rochester, New York	02660 Bunker Ramo Corp., Conn Div. Formerly Amphenol-Borg Electric Corp. Broadview, Illinois	04946 Standard Wire & Cable Los Angeles, California	06751 Components, Inc. Semcor Div. Phoenix, Arizona
00327 Weiwyn International, Inc Westlake, Ohio	02799 Areo Capacitors, Inc. Chatsworth, California	05082 Replaced by 94988	06860 Gould Automotive Div. City of Industry, California
00656 Aerovox Corp. New Bedford, Massachusetts	03508 General Electric Co. Semiconductor Products Syracuse, New York	05236 Jonathan Mfg. Co. Fullerton, California	06961 Vernitron Corp., Piezo Electric Div. Formerly Clevite Corp., Piezo Electric Div. Bedford, Ohio
00686 Film Capacitors, Inc. Passaic, New Jersey	03614 Replaced by 71400	05245 Components Corp. now Corcom, Inc. Chicago, Illinois	06980 Eimac Div. Varian Associates San Carlos, California
00779 AMP Inc. Harrisburg, Pennsylvania	03651 Replaced by 44655	05277 Westinghouse Electric Corp. Semiconductor Div. Youngwood, Pennsylvania	07047 The Ross Milton Co. South Hampton, Pennsylvania
01121 Allen-Bradley Co. Milwaukee, Wisconsin	03797 Eidema Div. Genisco Technology Corp. Compton, California	05278 Replaced by 43543	07115 Replaced by 14674
01281 TRW Electronic Comp. Semiconductor Operations Lawndale, California	03877 Transistron Electronic Corp. Wakefield, Massachusetts	05279 Southwest Machine & Plastic Co. Glendora, California	07138 Westinghouse Electric Corp., Electronic Tube Div. Horsehead, New York
01295 Texas Instruments, Inc. Semiconductor Group Dallas, Texas	03888 KDI Pyrofilm Corp. Whippany, New Jersey	05397 Union Carbide Corp. Materials Systems Div. New York, New York	07233 TRW Electronic Components Cinch Graphic City of Industry, California
01537 Motorola Communications & Electronics Inc. Franklin Park, Illinois	03911 Clairex Electronics Div. Clairex Corp. Mt. Vernon, New York	05571 Use 56289 Sprague Electric Co. Pacific Div. Los Angeles, California	07256 Silicon Transistor Corp. Div. of BBF Group Inc. Chelmsford, Massachusetts
01686 RCL Electronics Inc. Manchester, New Hampshire	03980 Muirhead Inc. Mountainside, New Jersey	05574 Viking Industries Chatsworth, California	07261 Aumet Corp. Culver City, California
01730 Replaced by 73586	04009 Arrow Hart Inc. Hartford, Connecticut	05704 Replaced by 16258	07263 Fairchild Semiconductor Div. of Fairchild Camera & Instrument Corp. Mountain View, California
01884 Use 56289 Sprague Electric Co. Dearborn Electronic Div. Lockwood, Florida	04062 Replaced by 72136	05820 Wakefield Engineering Inc. Wakefield, Massachusetts	07344 Bircher Co., Inc. Rochester, New York
02114 Ferroxcube Corp. Saugerties, New York	04202 Replaced by 81312	06001 General Electric Co. Electronic Capacitor & Battery Products Dept. Columbia, South Carolina	07597 Burndy Corp. Tape/Cable Div. Rochester, New York
02131 General Instrument Corp. Harris ASW Div. Westwood, Maine	04217 Essex International Inc. Wire & Cable Div. Anaheim, California	06136 Replaced by 63743	07792 Lerma Engineering Corp. Northampton, Massachusetts
02395 Rason Mfg. Co. Brooklyn, New York	04221 Aemco, Div. of Midtex Inc. Mankato, Minnesota	06383 Panduit Corp. Tinley Park, Illinois	07910 Teledyne Semiconductor Formerly Continental Device Hawthorne, California
02533 Snelgrove, C.R. Co., Ltd. Don Mills, Ontario, Canada M3B 1M2	04222 AVX Ceramics Div. AVX Corp. Myrtle Beach, Florida	06473 Bunker Ramo Corp. Amphenol SAMS Div. Chatsworth, California	07933 Use 49956 Raytheon Co. Semiconductor Div. HQ Mountain View, California
02606 Fenwal Labs Div. of Travenal Labs. Morton Grove, Illinois	04423 Telonic Industries Laguna Beach, California	06555 Beede Electrical Instrument Co. Penacook, New Hampshire	08225 Industro Transistor Corp. Long Island City, New York
	04645 Replaced by 75376	06739 Electron Corp. Littleton, Colorado	
	04713 Motorola Inc. Semiconductor Products Phoenix, Arizona	06743 Clevite Corp. Cleveland, Ohio	

Federal Supply Codes for Manufacturers (cont)

08261 Spectra Strip Corp. Garden Grove, California	11726 Qualidyne Corp. Santa Clara, California	13606 Use 56289 Sprague Electric Co. Transistor Div. Concord, New Hampshire	16299 Corning Glass Electronic Components Div. Raleigh, North Carolina
08530 Reliance Mica Corp. Brooklyn, New York	12014 Chicago Rivet & Machine Co. Bellwood, Illinois	13839 Replaced by 23732	16332 Replaced by 28478
08806 General Electric Co. Miniature Lamp Products Dept Cleveland, Ohio	12040 National Semiconductor Corp. Danbury, Connecticut	14099 Semtech Corp. Newbury Park, California	16473 Cambridge Scientific Ind. Div. of Chemed Corporation Cambridge, Maryland
08863 Nylomatic Corp. Norrisville, Pennsylvania	12060 Diodes, Inc. Chatsworth, California	14140 Edison Electronic Div. Mc Gray-Edison Co. Manchester, New Hampshire	16742 Paramount Plastics Fabricators, Inc. Downey, California
08988 Use 53085 Skottie Electronics Inc. Archbald, Pennsylvania	12136 Philadelphia Handle Co. Camden, New Jersey	14193 Cal-R-Inc. formerly California Resistor, Corp. Santa Monica, California	16758 Delco Electronics Div. of General Motors Corp. Kokomo, Indiana
09214 G.E. Co. Semi-Conductor Products Dept. Power Semi-Conductor Products OPN Sec. Auburn, New York	12300 Potter-Brumfield Div. AMF Canada LTD. Guelph, Ontario, Canada	14298 American Components, Inc. an Insilco Co. Conshohocken, Pennsylvania	17001 Replaced by 71468
09353 C and K Components Watertown, Massachusetts	12323 Presin Co., Inc. Shelton, Connecticut	14655 Cornell-Dubier Electronics Division of Federal Pacific Electric Co. Govt. Control Dept. Newark, New Jersey	17069 Circuit Structures Lab. Burbank, California
09423 Scientific Components, Inc. Santa Barbara, California	12327 Freeway Corp. formerly Freeway Washer & Stamping Co. Cleveland, Ohio	14752 Electro Cube Inc. San Gabriel, California	17338 High Pressure Eng. Co., Inc. Oklahoma City, Oklahoma
09922 Burndy Corp. Norwalk, Connecticut	12443 The Budd Co. Polychem Products Plastic Products Div. Bridgeport, Pennsylvania	14869 Replaced by 96853	17545 Atlantic Semiconductors, Inc. Asbury Park, New Jersey
09969 Dale Electronics Inc. Yankton, S. Dakota	12615 U.S. Terminals Inc. Cincinnati, Ohio	14936 General Instrument Corp. Semi Conductor Products Group Hicksville, New York	17856 Siliconix, Inc. Santa Clara, California
10059 Barker Engineering Corp. Formerly Amerace, Amerace ESNA Corp. Kenilworth, New Jersey	12617 Hamiin Inc. Lake Mills, Wisconsin	15636 Elec-Trol Inc. Saugus, California	17870 Replaced by 14140
11236 CTS of Berne Berne, Indiana	12697 Clarostat Mfg. Co. Dover, New Hampshire	15801 Fenwal Electronics Inc. Div. of Kidde Walter and Co., Inc. Framingham, Massachusetts	18178 Vactec Inc. Maryland Heights, Missouri
11237 CTS Keene Inc. Paso Robles, California	12749 James Electronics Chicago, Illinois	15818 Teledyne Semiconductors, formerly Amelco Semiconductor Mountain View, California	18324 Signetics Corp. Sunnyvale, California
11358 CBS Electronic Div. Columbia Broadcasting System Newburyport, Minnesota	12856 Micrometals Sierra Madre, California	15849 Litton Systems Inc. Useco Div. formerly Useco Inc. Van Nuys, California	18612 Vishay Resistor Products Div. Vishay Intertechnology Inc. Malvern, Pennsylvania
11403 Best Products Co. Chicago, Illinois	12954 Dickson Electronics Corp. Scottsdale, Arizona	15898 International Business Machines Corp. Essex Junction, Vermont	18736 Voltronics Corp. Hanover, New Jersey
11503 Keystone Columbia Inc. Warren, Michigan	12969 Unitrode Corp. Watertown, Massachusetts	15909 Replaced by 14140	18927 GTE Sylvania Inc. Precision Material Group Parts Division Titusville, Pennsylvania
11532 Teledyne Relays Hawthorne, California	13103 Thermalloy Co., Inc. Dallas, Texas	16258 Space-Lok Inc. Burbank, California	19451 Perine Machinery & Supply Co. Seattle, Washington
11711 General Instrument Corp. Rectifier Division Hicksville, New York	13327 Solitron Devices Inc. Tappan, New York		19701 Electro-Midland Corp. Mepco-Electra Inc. Mineral Wells, Texas
	13511 Amphenol Cadre Div. Bunker-Ramo Corp. Los Gatos, California		20584 Enochs Mfg. Inc. Indianapolis, Indiana

Federal Supply Codes for Manufacturers (cont)

20891 Self-Organizing Systems, Inc. Dallas, Texas	28480 Hewlett Packard Co. Corporate HQ Palo Alto, California	43543 Nytronics Inc. Transformer Co. Div. Geneva, New York	70903 Belden Corp. Geneva, Illinois
21604 Bucheye Stamping Co. Columbus, Ohio	28520 Heyman Mfg. Co. Kenilworth, New Jersey	44655 Ohmite Mfg. Co. Skokie, Illinois	71002 Birnback Radio Co., Inc. Freeport, New York
21845 Solitron Devices Inc. Transistor Division Riviera Beach, Florida	29083 Monsanto, Co., Inc. Santa Clara, California	49671 RCA Corp. New York, New York	71400 Bussmann Mfg. Div. of McGraw-Edison Co. Saint Louis, Missouri
22767 ITT Semiconductors Palo Alto, California	29604 Stackpole Components Co. Raleigh, North Carolina	49956 Raytheon Company Lexington, Massachusetts	71450 CTS Corp. Elkhart, Indiana
23050 Product Comp. Corp. Mount Vernon, New York	30148 AB Enterprise Inc. Ahoskie, North Carolina	50088 Mostek Corp. Carrollton, Texas	71468 ITT Cannon Electric Inc. Santa Ana, California
23732 Tracor Inc. Rockville, Maryland	30323 Illinois Tool Works, Inc. Chicago, Illinois	50579 Litronix Inc. Cupertino, California	71482 Clare, C.P. & Co. Chicago, Illinois
23880 Stanford Applied Engrng. Santa Clara, California	31091 Optimax Inc. Colmar, Pennsylvania	51605 Scientific Components Inc. Linden, New Jersey	71590 Centrelab Electronics Div. of Globe Union Inc. Milwaukee, Wisconsin
23936 Pamotor Div., Wm. J. Purdy Co. Burlingame, California	32539 Mura Corp. Great Neck, New York	53021 Sangamo Electric Co. Springfield, Illinois	71707 Coto Coil Co., Inc. Providence, Rhode Island
24248 Replaced by 94222	32767 Griffith Plastic Corp. Burlingame, California	54294 Cutler-Hammer Inc. formerly Shallcross, A Cutter-Hammer Co. Selma, North Carolina	71744 Chicago Miniature Lamp Works Chicago, Illinois
24355 Analog Devices Inc. Norwood, Massachusetts	32879 Advanced Mechanical Components Northridge, California	55026 Simpson Electric Co. Div. of Am. Gage and Mach. Co. Elgin, Illinois	71785 TRW Electronics Components Cinch Connector Operations Div. Elk Grove Village Chicago, Illinois
24655 General Radio Concord, Massachusetts	32897 Erie Technological Products, Inc. Frequency Control Div. Carlisle, Pennsylvania	56289 Sprague Electric Co. North Adams, Massachusetts	72005 Wilber B. Driver Co. Newark, New Jersey
24759 Lenox-Fugle Electronics Inc. South Plainfield, New Jersey	32997 Bourns Inc. Trimpot Products Division Riverside, California	58474 Superior Electric Co. Bristol, Connecticut	72092 Replaced by 06980
25088 Siemen Corp. Isilen, New Jersey	33173 General Electric Co. Products Dept. Owensboro, Kentucky	60399 Torin Corp. formerly Torrington Mfg. Co. Torrington, Connecticut	72136 Electro Motive Mfg. Co. Williamantic, Connecticut
25403 Amperex Electronic Corp. Semiconductor & Micro-Circuits Div. Slatersville, Rhode Island	34333 Silicon General Westminister, California	63743 Ward Leonard Electric Co., Inc. Mount Vernon, New York	72259 Nytronics Inc. Pelham Manor, New Jersey
27014 National Semiconductor Corp. Santa Clara, California	34335 Advanced Micro Devices Sunnyvale, California	64834 West Mfg. Co. San Francisco, California	72619 Dialight Div. Amperex Electronic Corp. Brooklyn, New York
27264 Mofex Products Downers Grove, Illinois	34802 Electromotive Inc. Kenilworth, New Jersey	65092 Weston Instruments Inc. Newark, New Jersey	72653 G.C. Electronics Div. of Hydrometals, Inc. Brooklyn, New York
28213 Minnesota Mining & Mfg. Co. Consumer Products Div. St. Paul, Minnesota	37942 P.R. Mallory & Co., Inc. Indianapolis, Indiana	66150 Winslow Tele-Tronics Inc. Eaton Town, New Jersey	72665 Replaced by 90303
28425 Serv-/Link formerly Bohannon Industries Fort Worth, Texas	42498 National Radio Melrose, Massachusetts	70485 Atlantic India Rubber Works Chicago, Illinois	72794 Dzus Fastener Co., Inc. West Islip, New York
28478 Deltrol Controls Div. Deltrol Corporation Milwaukee, Wisconsin		70563 Amperite Company Union City, New Jersey	72928 Gulton Ind. Inc. Gudeman Div. Chicago, Illinois

Federal Supply Codes for Manufacturers (cont)

72982 Erie Tech. Products Inc. Erie, Pennsylvania	75382 Kulka Electric Corp. Mount Vernon, New York	80583 Hammarlund Mfg. Co., Inc. Red Bank, New Jersey	83594 Burrhoughs Corp. Electronic Components Div. Plainfield, New Jersey
73138 Bechman Instrument Inc. Helipot Division Fullerton, California	75915 Littlefuse Inc. Des Plaines, Illinois	80640 Arnold Stevens, Inc. South Boston, Massachusetts	83740 Union Carbide Corp. Battery Products Div. formerly Consumer Products Div. New York, New York
73293 Hughes Aircraft Co. Electron Dynamics Div. Torrance, California	76854 Oak Industries Inc. Switch Div. Crystal Lake, Illinois	81073 Grayhill, Inc. La Grange, Illinois	84171 Arco Electronics Great Neck, New York
73445 Amperex Electronic Corp. Hicksville, New York	77342 AMF Inc. Potter & Brumfield Div. Princeton, Indiana	81312 Winchester Electronics Div. of Litton Industries Inc. Oakville, Connecticut	84411 TRW Electronic Components TRW Capacitors Ogallala, Nebraska
73559 Carling Electric Inc. West Hartford, Connecticut	77638 General Instrument Corp. Rectifier Division Brooklyn, New York	81483 Therm-O-Disc Inc. Mansfield, Ohio	84613 Fuse Indicator Corp. Rockville, Maryland
73586 Circle F Industries Trenton, New Jersey	77969 Rubbercraft Corp. of CA. LTD. Torrance, California	81483 International Rectifier Corp. Los Angeles, California	84682 Essex International Inc. Industrial Wire Div. Peabody, Massachusetts
73734 Federal Screw Products, Inc. Chicago, Illinois	78189 Shakeproof Div. of Illinois Tool Works Inc. Elgin, Illinois	81590 Korry Mfg. Co. Seattle, Washington	86577 Precision Metal Products of Maiden Inc. Stoneham, Massachusetts
73743 Fischer Special Mfg. Co. Cincinnati, Ohio	78277 Sigma Instruments, Inc. South Braintree, Massachusetts	81741 Chicago Lock Co. Chicago, Illinois	86684 Radio Corp. of America Electronic Components Div. Harrison, New Jersey
73899 JFD Electronics Co. Components Corp. Brooklyn, New York	78488 Stackpole Carbon Co. Saint Marys, Pennsylvania	82305 Palmer Electronics Corp. South Gate, California	86928 Seastrom Mfg. Co., Inc. Glendale, California
73949 Guardian Electric Mfg. Co. Chicago, Illinois	78553 Eaton Corp. Engineered Fastener Div. Tinnerman Plant Cleveland, Ohio	82389 Switchcraft Inc. Chicago, Illinois	87034 Illuminated Products Inc. Subsidiary of Oak Industries Inc. Anahiem, California
74199 Quan Nichols Co. Chicago, Illinois	79136 Waldes Kohinor Inc. Long Island City, New York	82415 North American Phillips Controls Corp. Frederick, Maryland	88219 Gould Inc. Industrial Div. Trenton, New Jersey
74217 Radio Switch Corp. Marlboro, New Jersey	79497 Western Rubber Company Goshen, Indiana	82872 Roanwell Corp. New York, New York	88245 Litton Systems Inc. Useco Div. Van Nuys, California
74276 Signalite Div. General Instrument Corp. Neptune, New Jersey	79963 Zierick Mfg. Corp. Mt. Kisko, New York	82877 Rotron Inc. Woodstock, New York	88419 Corneil-Dubilier Electronic Div. Federal Pacific Co. Fuquay-Varian, North Carolina
74306 Piezo Crystal Co. Carlisle, Pennsylvania	80031 Electro-Midland Corp. Mepco Div. A North American Phillips Co. Norristown, New Jersey	82879 ITT Royal Electric Div. Pawtucket, Rhode Island	88486 Plastic Wire & Cable Jewett City, Connecticut
74542 Hoyt Elect. Instr. Works Penacook, New Hampshire	80145 LFE Corp., Process Control Div. formerly API Instrument Co. Chesterland, Ohio	83058 The Carr Co., United Can Div. of TRW Cambridge, Massachusetts	88690 Replaced by 04217
74970 Johnson E.F., Co. Waseca, Minnesota	80183 Use 56289 Sprague Products North Adams, Massachusetts	83298 Bendix Corp. Electric Power Div. Eatontown, New Jersey	89536 John Fluke Mfg. Co., Inc. Seattle, Washington
75042 TRW Electronics Components IRC Fixed Resistors Philadelphia, Pennsylvania	80294 Bourns Inc., Instrument Div. Riverside, California	83330 Herman H. Smith, Inc. Brooklyn, New York	89730 G.E. Co., Newark Lamp Works Newark, New Jersey
75376 Kurz-Kasch Inc. Dayton, Ohio		83478 Rubbercraft Corp. of America, Inc. West Haven, Connecticut	
75378 CTS Knights Inc. Sandwich, Illinois			

Federal Supply Codes for Manufacturers (cont)

90201 Mallory Capacitor Co. Div. of P.R. Mallory Co., Inc. Indianapolis, Indiana	91836 King's Electronics Co., Inc. Tuckahoe, New York	95354 Methode Mfg. Corp. Rolling Meadows, Illinois	98291 Sealectro Corp. Mamaroneck, New York
90211 Use 56365 Square D Co. Chicago, Illinois	91929 Honeywell Inc. Micro Switch Div. Freeport, Illinois	95712 Bendix Corp. Electrical Components Div. Microwave Devices Plant Franklin, Indiana	98388 Royal Industries Products Div. San Diego, California
90215 Best Stamp & Mfg. Co. Kansas City, Missouri	91934 Miller Electric Co., Inc. Div. of Aunet Woonsocket, Rhode Island	95987 Weckesser Co. Inc. Chicago, Illinois	98743 Replaced by 12749
90303 Mallory Battery Co. Div. of Mallory Co., Inc. Tarrytown, New York	92194 Alpha Wire Corp. Elizabeth, New Jersey	96733 San Fernando Electric Mfg. Co. San Fernando, California	98925 Replaced by 14433
91094 Essex International Inc. Suglex/IWP Div. Newmarket, New Hampshire	93332 Sylvania Electric Products Semiconductor Products Div. Woburn, Massachusetts	96853 Gulton Industries Inc. Measurement and Controls Div. formerly Rustrak Instruments Co. Manchester, New Hampshire	99120 Plastic Capacitors, Inc. Chicago, Illinois
91293 Johanson Mfg. Co. Boonton, New Jersey	94145 Replaced by 49956	96881 Thomson Industries, Inc. Manhasset, New York	99217 Bell Industries Elect. Comp. Div. formerly Southern Elect. Div. Burbank, California
91407 Replaced by 58474	94154 Use 94988 Wagner Electric Corp. Tung-Sol Div. Newark, New Jersey	97540 Master Mobile Mounts, Div. of Whitehall Electronics Corp. Ft. Meyers, Florida	99392 STM Oakland, California
91502 Associated Machine Santa Clara, California	94222 Southco Inc. formerly South Chester Corp. Lester, Pennsylvania	97913 Industrial Electronic Hardware Corp. New York, New York	99515 ITT Jennings Monrovia Plant Div. of ITT Jennings formerly Marshall Industries Capacitor Div. Monrovia, California
91506 Augat Inc. Attleboro, Massachusetts	95146 Alco Electronic Products Inc. Lawrence, Massachusetts	97945 Penwalt Corp. SS White Industrial Products Div. Piscataway, New Jersey	99779 Use 29587 Bunker-Ramo Corp. Barnes Div. Landsdowne, Pennsylvania
91637 Dale Electronics Inc. Columbus, Nebraska	95263 Leecraft Mfg. Co. Long Island City, New York	97966 Replaced by 11358	99800 American Precision Industries Inc. Delevan Division East Aurora, New York
91662 Elco Corp. Willow Grove, Pennsylvania	95264 Replaced by 98278	98094 Replaced by 49956	99942 Centrelab Semiconductor Centrelab Electronics Div. of Globe-Union Inc. El Monte, California
91737 Use 71468 Gremar Mfg. Co., Inc. ITT Cannon/Gremar Santa Ana, California	95275 Vitramon Inc. Bridgeport, Connecticut	98159 Rubber-Teck, Inc. Gardena, California	Toyo Electronics (R-Ohm Corp.) Irvine, California
91802 Industrial Devices, Inc. Edgewater, New Jersey	95303 RCA Corp. Receiving Tube Div. Cincinnati, Ohio	98278 Malco A Microdot Co., Inc. Connector & Cable Div. Pasadena, California	National Connector Minneapolis, Minnesota
91833 Keystone Electronics Corp. New York, New York	95348 Gordo's Corp. Bloomfield, New Jersey		

1
2
3
4
5
6
7
8
9
10
11
12
13
14
15
16
17
18
19
20
21
22
23
24
25
26
27
28
29
30
31
32
33
34
35
36
37
38
39
40
41
42
43
44
45
46
47
48
49
50
51
52
53
54
55
56
57
58
59
60
61
62
63
64
65
66
67
68
69
70
71
72
73
74
75
76
77
78
79
80
81
82
83
84
85
86
87
88
89
90
91
92
93
94
95
96
97
98
99
100

U.S. SALES AREAS for all Fluke products

AL, Huntsville

John Fluke Mfg. Co., Inc.
3322 S. Memorial Parkway
Suite 96
Huntsville, AL 35801
(205) 881-6220

AZ, Tempe

John Fluke Mfg. Co., Inc.
2211 S. 48th Street
Suite B
Tempe, AZ 85282
(602) 438-8314

Tucson

(602) 790-9881

CA, Irvine

P.O. Box 19676
Irvine, CA 92713
16969 Von Karman
Suite 100
Irvine, CA 92714
(714) 863-9031

Los Angeles

John Fluke Mfg. Co., Inc.
20902 South Bonita St.
Carson, CA 90746
(213) 538-3900

San Diego

John Fluke Mfg. Co., Inc.
4540 Kearny Villa Rd., Suite 115
San Diego, CA 92123
(619) 292-7656

Santa Clara

John Fluke Mfg. Co., Inc.
2300 Walsh Ave., Bldg. K
Santa Clara, CA 95051
(408) 727-0513

CO, Denver

John Fluke Mfg. Co., Inc.
1980 South Quebec St. #4
Denver, CO 80231
(303) 750-1222

CT, Hartford

John Fluke Mfg. Co., Inc.
Glen Lochen East
41-C New London Turnpike
Glastonbury, CT 06033
(203) 659-3541

FL, Orlando

John Fluke Mfg. Co., Inc.
940 N. Fern Creek Ave.
Orlando, FL 32803
(305) 896-4881

GA, Atlanta

John Fluke Mfg. Co., Inc.
2700 Delk Rd., Suite 250
Marietta, GA 30067
(404) 953-4747

IA, Iowa City

(319) 354-2811

IL, Chicago

John Fluke Mfg. Co., Inc.
3740 Industrial Ave.
Rolling Meadows, IL 60008
(312) 398-0850

IN, Indianapolis

John Fluke Mfg. Co., Inc.
8777 Purdue Road
Suite 101
Indianapolis, IN 46268
(317) 875-7870

KS, Kansas City

(913) 381-9800

LA, New Orleans

(504) 455-0814

MA, Burlington

John Fluke Mfg. Co., Inc.
25 "B" Street
Burlington MA 01803
(617) 273-4674

MD, Baltimore

(301) 792-7060

Rockville

John Fluke Mfg. Co., Inc.
5640 Fishers Lane
Rockville, MD 20852
(301) 770-1570

MI, Detroit

John Fluke Mfg. Co., Inc.
33031 Schoolcraft
Livonia, MI 48150
(313) 522-9140

MN, Bloomington

John Fluke Mfg. Co., Inc.
1801 E. 79th St., Suite 9
Bloomington, MN 55420
(612) 854-5526

MO, St. Louis

John Fluke Mfg. Co., Inc.
2029 Woodland Parkway
Suite 105
St. Louis, MO 63141
(314) 993-3805

NC, Greensboro

John Fluke Mfg. Co., Inc.
1310 Beaman Place
Greensboro, NC 27408
(919) 273-1918

NJ, Paramus

John Fluke Mfg. Co., Inc.
P.O. Box 930
West 75 Century Road
Paramus, NJ 07652
(201) 262-9550

NM, Albuquerque

John Fluke Mfg. Co., Inc.
1108 Alvarado Drive N.E.
Albuquerque, NM 87110
(505) 881-3550

NY, Rochester

John Fluke Mfg. Co., Inc.
4515 Culver Road
Rochester, NY 14622
(716) 323-1400

OH, Cleveland

John Fluke Mfg. Co., Inc.
7830 Freeway Circle
Middleburg Heights, OH 44130
(216) 234-4540

Columbus

(614) 889-5715

Dayton

John Fluke Mfg. Co., Inc.
4756 Fishburg Rd.
Dayton, OH 45424
(513) 233-2238

OK, Tulsa

(918) 749-0190

OR, Portland

John Fluke Mfg. Co., Inc.
2700 NW 185th
Suite 2080
Portland, OR 97229
(503) 629-5928

PA, Philadelphia

John Fluke Mfg. Co., Inc.
1010 West 8th Ave., Suite H
King of Prussia, PA 19406
(215) 265-4040

Pittsburgh

(412) 261-5171

TX, Austin

(512) 459-3344

Dallas

John Fluke Mfg. Co., Inc.
14400 Midway Road
Dallas, TX 75234
(214) 233-9990

Houston

John Fluke Mfg. Co., Inc.
4240 Blue Bonnet Dr.
Stafford, TX 77477
(713) 491-5995

San Antonio

John Fluke Mfg. Co., Inc.
10417 Guilfdale
San Antonio, TX 78216
(512) 340-2621

UT, Salt Lake City

6914 So. 3000 East
Suite 206
Salt Lake City, UT 82021
(801) 268-9331

WA, Seattle

John Fluke Mfg. Co., Inc.
5020 148th Ave. N.E.
Suite 110
Redmond, WA 98052
(206) 881-6966

Service Center Areas

CA, Burbank (213) 849-4641
CA, Santa Clara (408) 727-8121
CO, Denver (303) 750-1228
FL, Orlando (305) 896-2296
IL, Chicago (312) 398-5880
MA, Burlington (617) 273-4678
MD, Rockville (301) 770-1576
NJ, Paramus (201) 262-9550
TX, Dallas (214) 233-9945
WA, Everett (206) 356-5560

For more information on Fluke products or Sales Offices you may dial (800) 426-0361 toll-free in most of the U.S.A.
From Alaska, Hawaii, or Washington phone (206) 356-5400. From Canada and other countries phone (206) 356-5500.



John Fluke Mfg. Co., Inc., P.O. Box C9090, Everett, WA 98206
Fluke (Holland) B.V., P.O. Box 5053, 5004 EB, Tilburg, The Netherlands. Phone (013) 673973
Litho in U.S.A. 10/84

INTERNATIONAL SALES OFFICES

Argentina •

Coasin S.A.
Virrey del Pino 4071 DEP E-1
1430 CAP FED
Buenos Aires, Argentina
Tel: (1) 552-5248, TLX: (390) 22284

Australia •

Eimeasco Instruments Pty. Ltd.
P.O. Box 30
Concord, N.S.W. 2137
Australia
Tel: (2) 736-2888, TLX: (790) 25887

Eimeasco Instruments Pty. Ltd.
21-23 Anthony Drive
Mt. Waverly, Victoria 3149
Australia
Tel: (3) 233-4044, TLX: (790) 36206

Eimeasco Instruments Pty. Ltd.
Professional Suites Bldg.
G.P.O. Box 2360
Brisbane 4001, Australia
Tel: (7) 369-8688, TLX: (790) 44062

Eimeasco Instruments Pty. Ltd.
G.P.O. Box 1240
Adelaide, South Australia 5001
Tel: (8) 271-1839

Eimeasco Instruments Pty. Ltd.
P.O. Box 95
Gosnells, West Australia 6110
Australia
Tel: (9) 398-3362

Austria •

Walter Rekirsch Elektronische
Geräte GmbH & Co.
Vertrieb KG
Obachgasse 28
1220 Vienna, Austria
Tel: (222) 235555, TLX: (847) 134759

Bangladesh •

Motherland Corporation
24 Hatkhola Road, Tikatuli
Dacca-3, Bangladesh
Tel: 257249, TLX: (950) 642022

Belgium •

Fluke (Belgium) S.A./N.V.
6 Rue de Geneve
1140 Brussels, Belgium
Tel: (2) 2164090, TLX: (846) 26312

Bolivia •

Coasin Bolivia S.R.L.
Casilla 7295
La Paz, Bolivia
Tel: (2) 40962, TLX: (336) 3233

Brazil •

Fluke Brasil-Industria e
Comercio Ltda.
Al. Amazonas 422,
Alphaville, Barueri,
CEP 06400, Sao Paulo, Brazil
Tel: (11) 421-5477, TLX: (391) 1135589

Fluke Brasil-Industria e
Comercio Ltda.
Av. Henrique Valadares, No. 23/401
Rio de Janeiro, Brazil
Tel: (21) 252-1297

Brunei •

Rank O'Connor's Berhad, Ltd.
No. 8 Block D Sufri Complex
Mile 1 Jalan Tutong
Bandar Seri Begawan
Negara Brunei Darussalam
Tel: (2) 23109 or 23557
TLX: (799) BU2265 RANKOC

Canada •

Allan Crawford Assoc., Ltd.
6503 Northam Drive
Mississauga, Ontario
L4V 1J2 Canada
Tel: (416) 678-1500, TLX: 06968769

Allan Crawford Assoc., Ltd.
7018 Cote de Liesse
St. Laurent, Quebec
H4T 1E7 Canada
Tel: (514) 731-8564, TLX: 05824944

Allan Crawford Assoc., Ltd.
881 Lady Ellen Place
Ottawa, Ontario
K1Z 5L3 Canada
Tel: (613) 722-7682, TLX: 0533600

Allan Crawford Assoc., Ltd.
Suite 106
4180 Lougheed Hwy.
Burnaby, British Columbia
V5C 6A8 Canada
Tel: (604) 294-1326, TLX: 0454247

Allan Crawford Assoc., Ltd.
1935 30th Avenue, N.E.
Calgary, Alberta
T2E 6Z5 Canada
Tel: (403) 230-1341, TLX: 03821186

Chile •

Intronica Chile, Ltda.
Manuel Montt 024-Of.D
Casilla 16228
Santiago 9, Chile
Tel: (2) 44940, TLX: (332) 240301

China, Peoples Republic of •

Fluke International Corp.
P.O. Box C9090 M/S 206-A
Everett, WA 98206 U.S.A.
Tel: (206) 356-5511
TLX: 185103 FLUKE UT

Colombia •

Sistemas E Instrumentacion, Ltda.
Carrera 13, No. 37-43, Of. 401
Ap. Aereo 29583
Bogota DE, Colombia
Tel: 232-4532, TLX: (396) 45787

Cyprus •

Chris Radiovision, Ltd.
P.O. Box 1989
Nicosia, Cyprus
Tel: (21) 66121, TLX: (826) 2395

Cyprus, Northern

Ucok Buroteknik
2C & 2D Muftu Ziyai Street
Lefkosa, Northern Cyprus
Mersin 10, Turkey
Tel: (741) 357-20-71777, TLX: (821) 57267

Czechoslovakia •

Amtest Associates, Ltd.
Clarence House
31 Clarence Street
Staines, Middlesex TW18 4SY
England
Tel: (784) 63555, TLX: (851) 928855

Denmark •

Tage Olsen A/S
Ballerup Byvej 222
2750 Ballerup
Denmark
Tel: (2) 658111, TLX: (855) 35293

Ecuador •

Proteco Coasin Cia., Ltda.
P.O. Box 228-A
Ave. 12 de Octubre 2285
y Orellana
Quito, Ecuador
Tel: (2) 529684, TLX: (393) 2865

Proteco Coasin Cia., Ltda.
P.O. Box 9733
Ave. Principal No. 204
y Calle Segunda
Urbanizacion Miraflores
Guayaquil, Ecuador
Tel: (4) 387519

Egypt and Sudan •

Electronic Engineering Liaison Office
P.O. Box 2891 Horreya
11361 Heliopolis, Cairo
Egypt
Tel: (2) 695705, TLX: (927) 23082

England •

Fluke GB, Ltd
Colonial Way
Watford, Herts,
WD2 4TT England
Tel: (923) 40511, TLX: (851) 934583

Fiji •

Awa Fiji
47 Forster Road
Walu Bay
Suva, Fiji
Tel: 312079, TLX: (792) FJ2347

Finland •

Instrumentarium Electronics
P.O. Box 64
02631 Espoo 63
Finland
Tel: (0) 5281, TLX: (857) 124426

France •

M.B. Electronique S.A.
Rue Fournay
P.O. Box 31
78530 BUC, France
Tel: (3) 956-8131, TLX: (842) 695414

German Democratic Republic •

Amtest Associates, Ltd.
Clarence House
31 Clarence Street
Staines, Middlesex TW18 4SY
England
Tel: (784) 63555, TLX: (851) 928855

Germany, West •

Fluke (Deutschland) GmbH
Oskar-Messter-Strasse 18
WG-8045 Ismaning/Munich
West Germany
Tel: (089) 96050, TLX: (841) 0522472
Rapifax: 49-89-9605166

Fluke (Deutschland) GmbH

Viertriebsbüro - Dusseldorf
Meineckestrasse 53
D-4000 Dusseldorf-30
West Germany
Tel: (0211) 450831, TLX: (841) 08585576

Fluke (Deutschland) GmbH
Vertriebsbüro - Hamburg
Habichtsthorst 42
D-2000 Hamburg 61
West Germany
Tel: (40) 5519031, TLX: (841) 02174556

Greece •

Hellenic Scientific Representations Ltd.
11, Vrassida Street
Athens 612, Greece
Tel: (1) 7211140, TLX: (863) 219330

Hong Kong •

Schmidt & Co (H.K.), Ltd
18th Floor, Great Eagle Centre
23 Harbour Road
Wanchai, Hong Kong
Tel: (5) 8330-222
TLX: (780) 74766 or (780) 76762

Hungary •

Amtest Associates, Ltd.
Clarence House
31 Clarence Street
Staines, Middlesex TW18 4SY
England
Tel: (784) 63555, TLX: (851) 928855

India •

Hinditron Services Pvt., Ltd.
69/A.L. Jagmohandas Marg
Bombay 400 006, India
Tel: 8121316, 8125344, TLX: (953) 112326

Hinditron Services Pvt., Ltd.
8th Main Road
33/44A Raj Mahal Vijas Extension
Bangalore 560 080, India
Tel: 33139, TLX: (953) 0845741

Hinditron Services Pvt. Ltd.
Shantiniketan, Office No. 6
6th Floor, 8 Camac Street
Calcutta 700 017, India
Tel: 434032, 447541

Hinditron Services Pvt. Ltd.
204-5-6 Hemkunt Tower
98 Nehru Place
New Delhi, 110019, India
Tel: 640380, TLX: (953) 314890

Hinditron Services Pvt. Ltd.
Srinath Complex, 5th Floor
1-1-58/1 to 1-1-58/11
Sarojini Devi Road
Secunderabad 500 003, India
Tel: 821117, TLX: (953) 0155575

Indonesia •

P.T. Dwi Tunggal Jaya Sakti
P.O. Box 4435
Jalan Panglima Polim Raya #29
Kebayoran Baru
Jakarta Selatan, Indonesia
Tel: (21) 716374, TLX: (796) 47308

Ireland •

Euro Instruments & Electronics Ltd.
Euro House
Swords Road, Santry
Dublin 9, Ireland
Tel: (1) 425666, TLX: (851) 31821



John Fluke Mfg. Co., Inc. / PO Box C9090 / Everett, WA 98206 / (206) 356 5400

Litho in U.S.A. 10/84

Israel

R.D.T. Electronics Engineering Ltd.
P.O. Box 43137
Tel Aviv 61430
Israel
Tel: (3) 483211, TLX: (922) 32143

Italy

Sistrel S.p.A.
Via Peizza da Volpedo 59
20092 Cinisello Balsamo
Milan, Italy
Tel: (2) 6181893, TLX: (843) 334643

Sistrel S.p.A.
Via Giuseppe Armellini No. 39
00143 Rome, Italy
Tel: (6) 591-5551, TLX: (843) 680356

Sistrel S.p.A.

Via Cintia
Parco S. Paolo 35
80126 Naples, Italy
Tel: (81) 7679700

Japan

John Fluke Mfg. Co., Inc.
Japan Branch
Sumitomo Higashi Shinbashi Bldg.
1-1-11 Hamamatsucho
Minato-ku, Tokyo 105, Japan
Tel: (3) 434-0181, TLX: (781) 2424331

John Fluke Mfg. Co., Inc.

Japan Branch
SF Katsushige Building
2-45 Kohraibashi
Higashi-ku, Osaka 541
Japan
Tel: (6) 229-0871

Korea, Republic of

Electro-Science Korea Co.
201 Hyunjin Building
951-19 Bangbae-Dong Gangnam-ku
Seoul, Republic of Korea
Tel: (2) 583-7703, TLX: (787) 25381

Kuwait

Al Bahar International Group
P.O. Box 26672 Safat
Kuwait, Arabian Gulf
Tel: 848601, TLX: (959) 44822

Lebanon and Jordan

Mabek (Electronic Division)
P.O. Box 11-3823
Beirut, Lebanon
Tel: 812523, TLX: (923) 22889

Malaysia

Mecomb Malaysia SND BHD
Lot 20, Jalan 225
P.O. Box 24
Petaling Jaya, Malaysia
Tel: (3) 743422, TLX: (784) MA37764

Malta

Fabian Enterprises
20, Msida Road
Gzira, Malta
Tel: 513283/40216, TLX: (838) 1837

Mexico

Electronica y Tecnologia
Avanzada S.A. de C.V.
Pafnucio Padilla 53 5° Piso
Centro Comercial
53100 Ciudad Satelite
Estado de Mexico
Tel: (5) 3930902, TLX: (383) 172697

Mexicana de Electronica

Industrial, S.A. (Mexel)
Blvd. Ptd. Adolfo Lopez Mateos
Nos. 163 Col. Mixcoac
03910 Mexico
Tel: (5) 563-54-11, TLX: (383) 1771038

Nepal

Associated Enterprises
GPO Box 790, Pyaphal Toie
Kathmandu, Nepal
Tel: 13868

Netherlands

Fluke (Nederland) B.V.
Gasthuisring 14
P.O. Box 115
5000 AC Tilburg
The Netherlands
Tel: (13) 352455, TLX: (844) 52683

New Zealand

McLean Information Technology, Ltd.
459 Khyber Pass Road, Newmarket
P.O. Box 9464, Newmarket
Auckland 1, New Zealand
Tel: (9) 501-801, TLX: (791) NZ21570

McLean Information Technology, Ltd.
P.O. Box 496
Wellington, New Zealand
Tel: (4) 851-450 or 844-424

Norway

Morgenstjerne & Co A/S
Konghellegate 3
P.O. Box 6688 - Rodelokka
Oslo 5, Norway
Tel: (2) 356110, TLX: (856) 71719

Oman

OHI Telecommunications
P.O. Box 889
Muscat
Sultanate of Oman
Tel: 703862, TLX: (926) 3168

Pakistan

International Operations (PAK), Ltd.
505 Muhammadi House
I.I. Chundrigar Road
P.O. Box 5323, Karachi, Pakistan
Tel: (21) 221127, TLX: (952) 24494

Peru

Importaciones y Representaciones
Electronicas S.A.
Avda. Franklin D. Roosevelt 105
Lima 1, Peru
Tel: (14) 28-8650, TLX: (394) 25663

Philippines, Republic of

Spark Radio & Electronics, Inc.
452 Shaw Boulevard
Mandaluyong, Metro Manila
Republic of Philippines
Tel: (2) 775192, TLX: (722 or 732) 27901

Poland

Amtest Associates, Ltd.
Clarence House
31 Clarence Street
Staines, Middlesex TW18 4SY
England
Tel: (784) 63555, TLX: (851) 928855

Portugal

Decada Espectral
Equipamentos de Electronica
Av. Bombeiros Voluntarios
Lote 102B, Miraflores/Alges
1495 Lisbon, Portugal
Tel: (1) 2103420, TLX: (832) 15515

Qatar

Technology Organization
P.O. Box 5549
Doha, Qatar
Tel: 321431, TLX: (957) 4581

Rumania

Amtest Associates, Ltd.
Clarence House
31 Clarence Street
Staines, Middlesex TW18 4SY
England
Tel: (784) 63555, TLX: (851) 928855

Saudi Arabia

Electronic Equipment Marketing Co.
P.O. Box 3750
Riyadh, Saudi Arabia
Tel: (1) 477-1650, TLX: (928) 201120

Singapore, Republic of

Rank O'Connor's Singapore (PTE) Ltd.
O'Connor House
98 Pasir Panjang Road
Singapore 0511
Republic of Singapore
Tel: 637944, TLX: (786) RS21023

South Africa

Fluke S.A. (Pty) Ltd.
Wynberg Park
777 Andries Street
Wynberg, South Africa
Tel: (11) 786-3170, TLX: (960) 424328

Spain

ESSA
Equipos y Sistemas S.A.
C/Apolonio Morales, 13-B
Madrid 16, Spain
Tel: (1) 458-0150, TLX: (831) 42856

Sri Lanka

Computerlink Data Systems, Ltd.
294 Union Place
Colombo, 2, Sri Lanka
Tel: (1) 28641/2, TLX: (954) 21321

Sweden

Teleinstrument AB
Maltesholmsvagen 138
P.O. Box 4490
162 04 Vallingby 4
Sweden
Tel: (8) 380370, TLX: (854) 15770

Switzerland

Traco Electronic AG
Jenatschstrasse 1
8002 Zurich
Switzerland
Tel: (1) 201-0711, TLX: (845) 815570

Syria

Mabek (Electronic Division)
P.O. Box 4238
Damascus, Syria

Taiwan

Schmidt Electronics Corp.
6th Floor Cathay Min-Sheng
Commercial Building,
344 Min-Sheng East Road
Taipei 104, Taiwan
Tel: (2) 501-3468, TLX: (785) 10548

Thailand

Measuretronix Ltd.
2102/63 Ramkamhaeng Road
Bangkok 10240
Thailand
Tel: (2) 378-2516, TLX: (786) 81143

Tunisia

Selep S.A.R.L.
6, Rue de Sparte
Tunis - 1000 RP
Tunisia
Tel: (1) 248093, TLX: (934) 13030

Turkey

Erkman Elektronik Aletler
Ticaret Anonim Sirketi
Necatibey Cad 92/3
Karakoy, Istanbul, Turkey
Tel: (11) 4415461, TLX: (821) 24399

United Arab Emirates

Al-Sanani Cen. Trad. Est.
P.O. Box 7187
Abu-Dhabi, U.A.E.
Tel: (2) 821370 or 821371
TLX: (958) 23966

Haris Al-Afaq, Ltd.

P.O. Box 545
Sharjah, U.A.E.
Tel: (6) 359120, TLX: (958) 68540

Uruguay

Coasin Uruguaya S.A.
Libertad 2529
Casilla de Correo 1400
Montevideo, Uruguay
Tel: (2) 789015, TLX: (398) 6445

USSR

Amtest Associates, Ltd.
Clarence House
31 Clarence Street
Staines, Middlesex TW18 4SY
England
Tel: (784) 63555, TLX: (851) 928855

Venezuela

Coasin C.A.
Calle 9 Con Calle 4, Edif. Edinurbi
Apartado de Correos NR-70.136
Los Ruices
Caracas 1070-A, Venezuela
Tel: (2) 239-0967, TLX: (395) 21027

Yugoslavia

Amtest Associates, Ltd.
Clarence House
31 Clarence Street
Staines, Middlesex TW18 4SY
England
Tel: (784) 63555, TLX: (851) 928855

Supplied and Supported by —

Fluke (Holland) B.V.
P.O. Box 5053, 5004 EB Tilburg
Zevenheuvelenweg 53, 5048 AN Tilburg
The Netherlands
Tel: (013) 673973, TLX: 52237

Supplied and Supported by —

Fluke International Corporation
P.O. Box C9090
Everett, WA 98206 U.S.A.
Tel: (206) 356-5500
TLX: 152662 JOHN FLUKE EVT



TECHNICAL SERVICE CENTERS

U.S.A.

CA, Burbank

John Fluke Mfg. Co., Inc.
(213) 849-4641

CA, Santa Clara

John Fluke Mfg. Co., Inc.
(408) 727-8121

CO, Denver

John Fluke Mfg. Co., Inc.
(303) 750-1228

FL, Orlando

John Fluke Mfg. Co., Inc.
(305) 896-2296

IL, Rolling Meadows

John Fluke Mfg. Co., Inc.
(312) 398-5800

MA, Burlington

John Fluke Mfg. Co., Inc.
(617) 273-4678

MD, Rockville

John Fluke Mfg. Co., Inc.
(301) 770-1576

NJ, Paramus

John Fluke Mfg. Co., Inc.
(201) 262-9550

TX, Dallas

John Fluke Mfg. Co., Inc.
(214) 233-9945

WA, Everett

John Fluke Mfg. Co., Inc.
(206) 356-5560

Other Countries

Argentina, Buenos Aires

Coasin S.A.
Tel: 552-5248/3485
TLX: 22284 COASN AR

Australia, Concord

Elmeasco Instruments Pty Ltd.
Tel: 736-2888
TLX: 25887 ELSCO

Australia, Mount Waverley

Elmeasco Instruments Pty. Ltd.
Tel: 233-4044
TLX: 36206 ELMVIC

Australia, Brisbane

Elmeasco Instruments Pty. Ltd.
Tel: 369-8688
TLX: 44082 ELMQLD

Austria, Vienna

Walter Rekirsch
Elektronische Gerate GmbH & Co.
Tel: 235555
TLX: 134759

Belgium, Brussels

Fluke (Belgium) SA/NA
Tel: 2164090
TLX: 26312

Brazil, Sao Paulo

Fluke Brasil-Industria E Comercio Ltda.
Tel: 421-5477
TLX: 1135589 FLKE BR

Canada, Calgary, AB

Allan Crawford Associates Ltd.
Tel: (403) 230-1341

Canada, Burnaby, BC

Allan Crawford Associates Ltd.
Tel: (604) 294-1326

Canada, Mississauga, ON

Allan Crawford Associates Ltd.
Tel: (416) 678-1500

Canada, St. Laurent, PQ

Allan Crawford Associates Ltd.
Tel: (514) 731-8564

Chile, Santiago

Intronica Chile Ltda.
Tel: 44940
TLX: 240301

China, Beijing

Beijing Radio Research Institute
Tel: 445612

Colombia, Bogota

Sistemas E Instrumentacion, Ltda.
Tel: 232-4532
TLX: 45787 COASN CO

Denmark, Ballerup

Tage Olson A/S
Tel: 658111
TLX: 35293 TOAS DK

Ecuador, Quito

Proteco Coasin Cia., Ltda.
Tel: 529684, 526759
TLX: 2865 PROTEC ED

Egypt, Cairo

Electronic Engineering Liaison Office
Tel: 695705
TLX: 23082

England, Watford, Herts

Fluke (Great Britain) LTD
Tel: 40511
TLX: 934583

Finland, Espoo

Instrumentarium Electronics
Tel: 5281
TLX: 124426 HAVUL SF

France, Paris

M.B. Electronique S.A.
Tel: 9568131
TLX: 695414

Greece, Athens

Hellenic Scientific Representations
Tel: 7211140
TLX: 219330

Hong Kong, Wanchai

Schmidt & Co (H.K.) Ltd.
Tel: 8330-222
TLX: 74766 SCHMC HX

India, Bombay

Hinditron Services Pvt. Ltd.
Tel: 8121316
TLX: 112326 HSPL IN

India, Bangalore

Hinditron Services Pvt. Ltd.
Tel: 33139
TLX: 0845741 HSPL IN

India, New Delhi

Hinditron Services Pvt. Ltd.
Tel: 619118
TLX: 0314890 SRMP IN

Indonesia, Jakarta Selatan

P.T. Dwi Tunggal Jaya Sakti
Tel: 716374
TLX: 47308 DIJS IA

Israel, Ramat Hasharon

R.D.T. Electronics Engineering Ltd.
Tel: 483216
TLX: 32143 RDT IL

Italy, Milan

Sistrel S.p.A.
Tel: 6181893
TLX: 334643

Italy, Rome

Sistrel S.p.A.
Tel: 5915551
TLX: 680356

Japan, Tokyo

John Fluke Mfg. Co., Inc.
Japan Branch
Tel: 434-0185
TLX: 2424331 (FLUKJJP)

Korea, Seoul

Electro-Science Korea Co.
Tel: 583-7703
TLX: 25381 ESKOREA

Malaysia, Petaling Jaya

Mecomb Malaysia SDN BHD
Tel: 743422
TLX: MA37764 MECOMB

Mexico, Mexico D.F.

Electronica y Tecnologia
Avanzada S.A. de C.V. (ETA)
Tel: 393 09 02 or 393 57 62
TLX: 172697 BIOSME

Netherlands, Tilburg

Fluke (Nederland) B.V.
Tel: 352455
TLX: 52683

New Zealand, Auckland

McLean Information Technology, Ltd.
Tel: 501-801, 501-219
TLX: NZ21570 THERMAL

Norway, Oslo

Morgenstjerne & Co. A/S
Tel: 356110
TLX: 71719

Pakistan, Karachi

International Operations (PAK). Ltd.
Tel: 221127, 239052
TLX: 24494 PIO PK

Peru, Lima

Importaciones Y Representaciones
Electronicas S.A.
Tel: 288650
TLX: 25663 PE IREING

Philippines, Metro Manila

Spark Radio & Electronics Corp.
Tel: 775192, 704096
TLX: 27901 RLA PH

Portugal, Lisbon

Decada Espectral Equipamentos
de Electronica, Lda
Tel: 2103420
TLX: 15515

Republic of Singapore, Singapore

Rank O'Connor's (PTE) Limited
Tel: 637944, 239052
TLX: RS21023 OCONSIN

Republic of South Africa, Wynberg

Fluke S.A. (Pty) Ltd.
Tel: 786-3170
TLX: 424328

Spain, Madrid

Equipos y Sistemas S.A.
Tel: 458-0150
TLX: 42856 EYS E

Sweden, Vallingby

Teleinstrument AB
Tel: 380370
TLX: 15770

Switzerland, Zurich

Traco Electronic AG
Tel: 2010711
TLX: 815570 TRCO CH

Taiwan, Taipei

Schmidt Electronics Corp.
Tel: 5013468
TLX: 11111 SCHMIDT
10548 EVERGOFT

Thailand, Bangkok

Measuretronix Ltd.
Tel: 378-2516
TLX: 81143 DEJOBKK TH

Turkey, Istanbul

Erkman Elektronik Aletler
Tel: 4415461
TLX: 24399

Uruguay, Montevideo

Coasin Uruguaya S.A.
Tel: 789015
TLX: UY6571 OROCUER SA

Venezuela, Caracas

Coasin C.A.
Tel: 239-0967, 239-5079
TLX: 21027 EMVEN VE

West Germany, Ismaning/Munich

Fluke (Deutschland) GmbH
Tel: 96050
TLX: 0522472



John Fluke Mfg. Co., Inc., P.O. Box C9090, Everett, WA 98206

Fluke (Holland) B.V., P.O. Box 5053, 5004 EB, Tilburg, The Netherlands. Phone (013) 673973

Litho in U.S.A. 10/84

Section 7A

Manual Change Information

INTRODUCTION

This appendix contains information necessary to backdate the manual to conform with earlier pcb configurations. To identify the configuration of the pcb's used in your instrument, refer to the revision letter (marked in ink) on the component side of each pcb assembly. Table 7A-1 defines the assembly revision levels documented in this manual.

NEWER INSTRUMENTS

As changes and improvements are made to the instrument, they are identified by incrementing the

revision letter marked on the affected pcb assembly. These changes are documented on a supplemental change/errata sheet which, when applicable, is inserted at the front of the manual.

OLDER INSTRUMENTS

To backdate this manual to conform with earlier assembly revision levels, perform the changes indicated in Table 7A-1.

CHANGES

There are no backdating changes at this printing. All pcb assemblies are documented at their original revision level.

Section 8

Schematic Diagrams

TABLE OF CONTENTS

FIGURE	TITLE	PAGE
8-1.	Interconnect Diagram	8-3
8-2.	A1 LED, A2 Mother Board and A6 Battery Module PCB Assemblies	8-4
8-3.	A3 Pre-Regulator PCB Assembly	8-6
8-4.	A4 Regulator PCB Assembly	8-8
8-5.	A5 Reference PCB Assembly	8-10

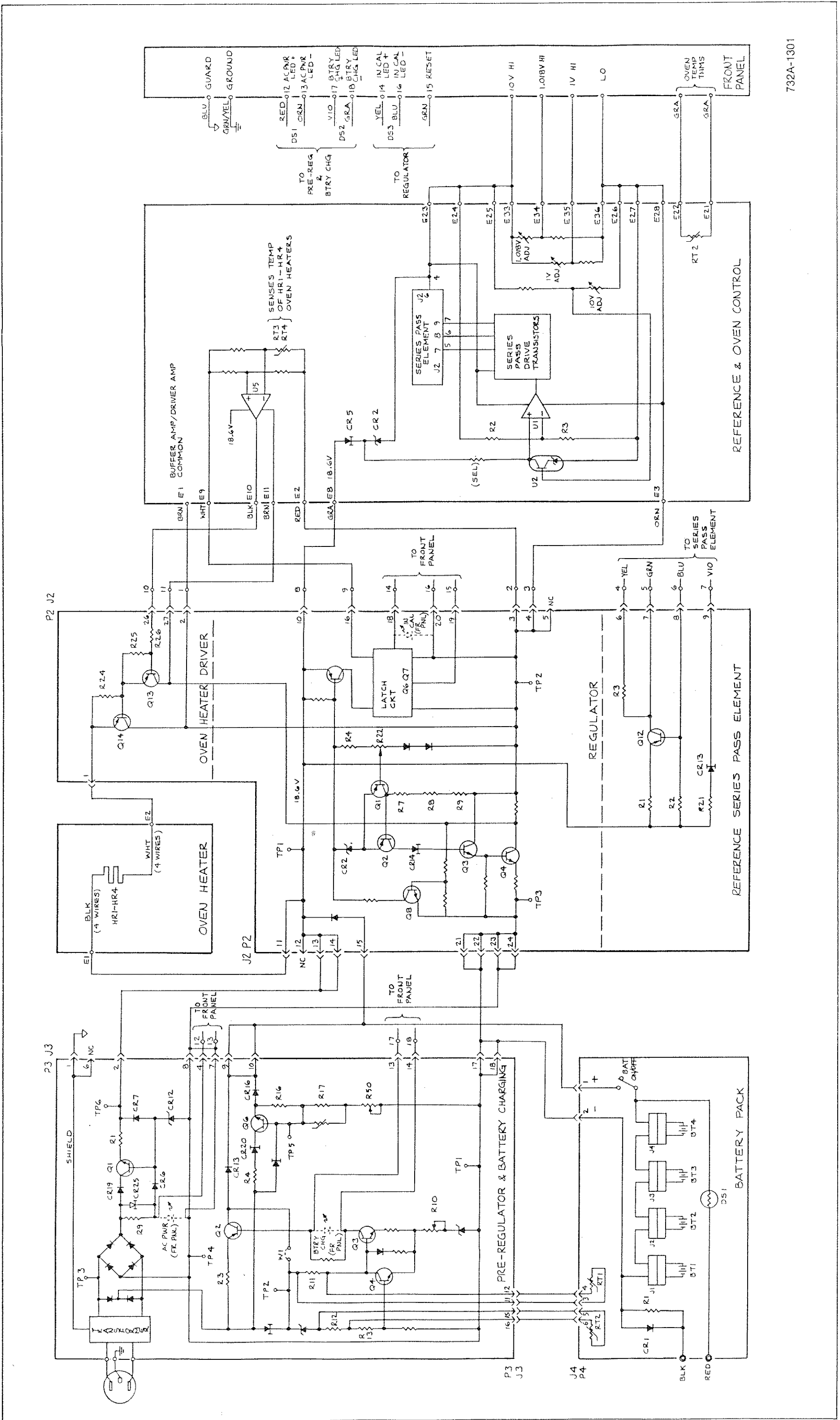

732A-1301

Figure 8-1. Interconnect Diagram

732A

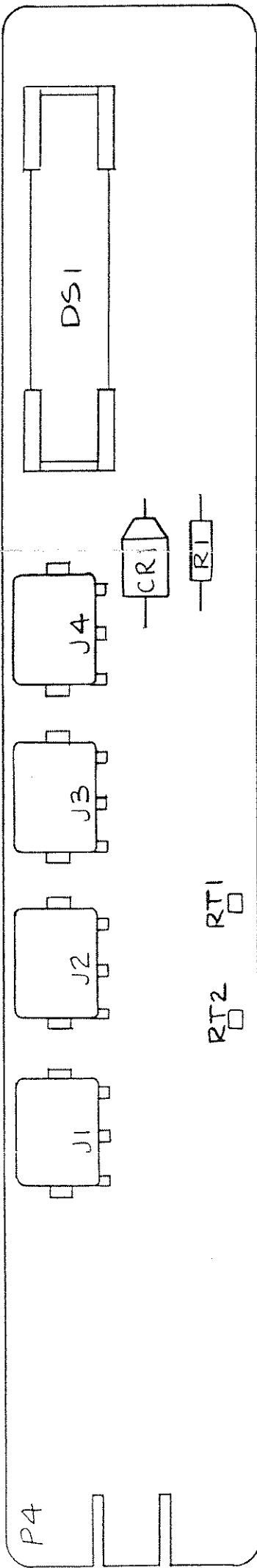
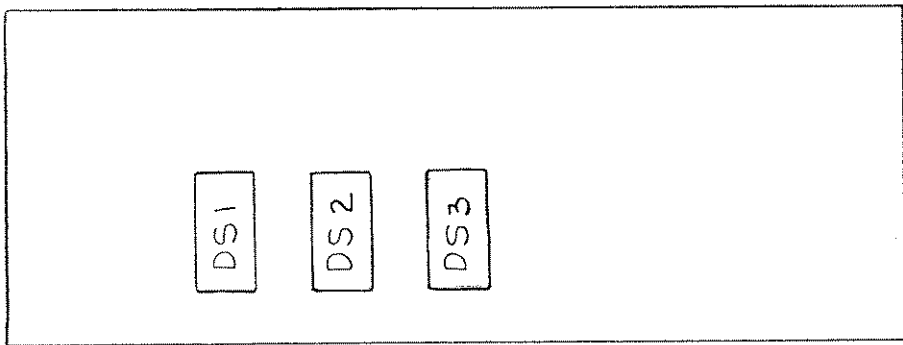
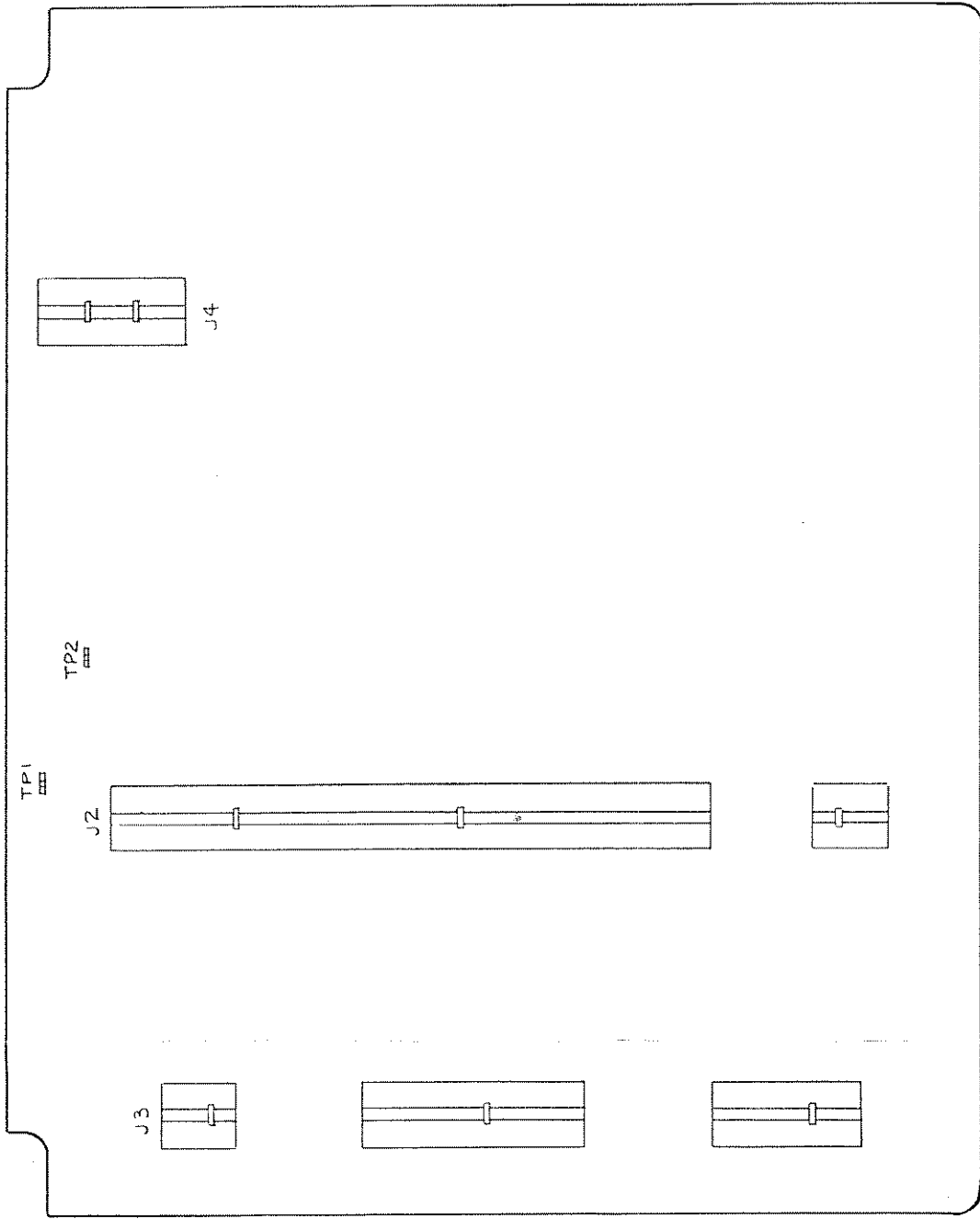
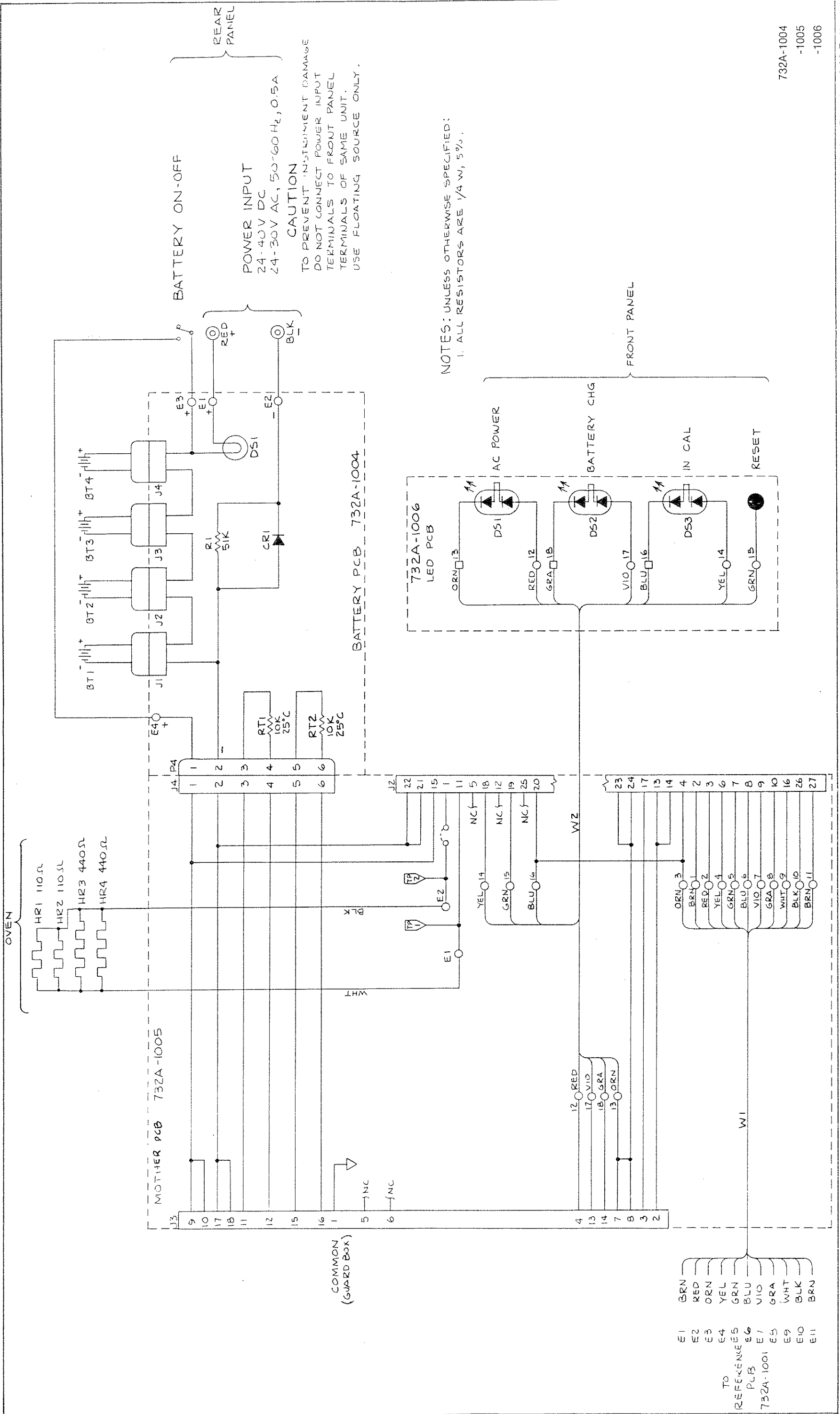

Figure 8-2. A1 LED, A2 Mother Board and A6 Battery Module PCB Assemblies



732A-1004
 -1005
 -1006

Figure 8-2. A1 LED, A2 Mother Board and A6 Battery Module PCB Assemblies (cont)

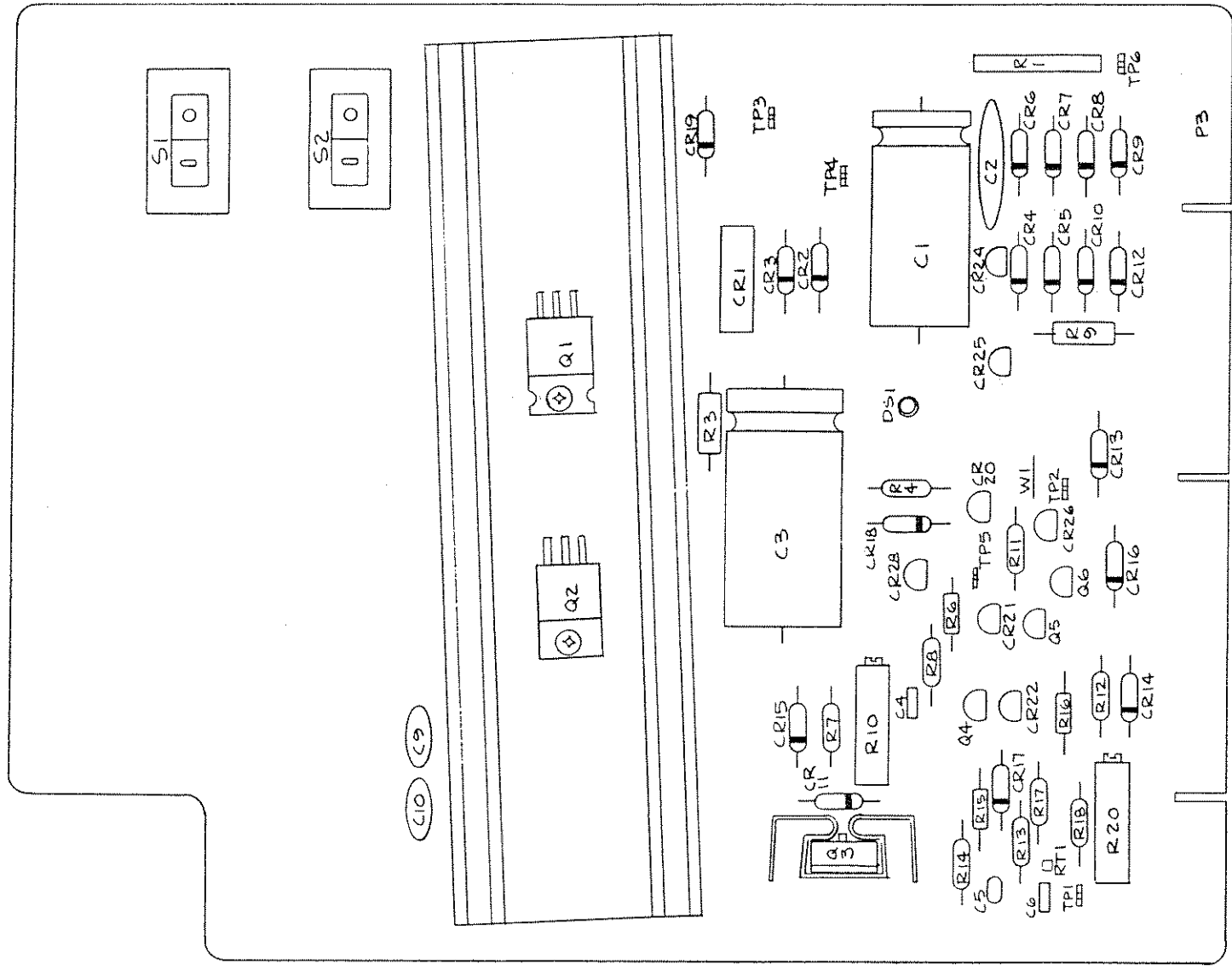
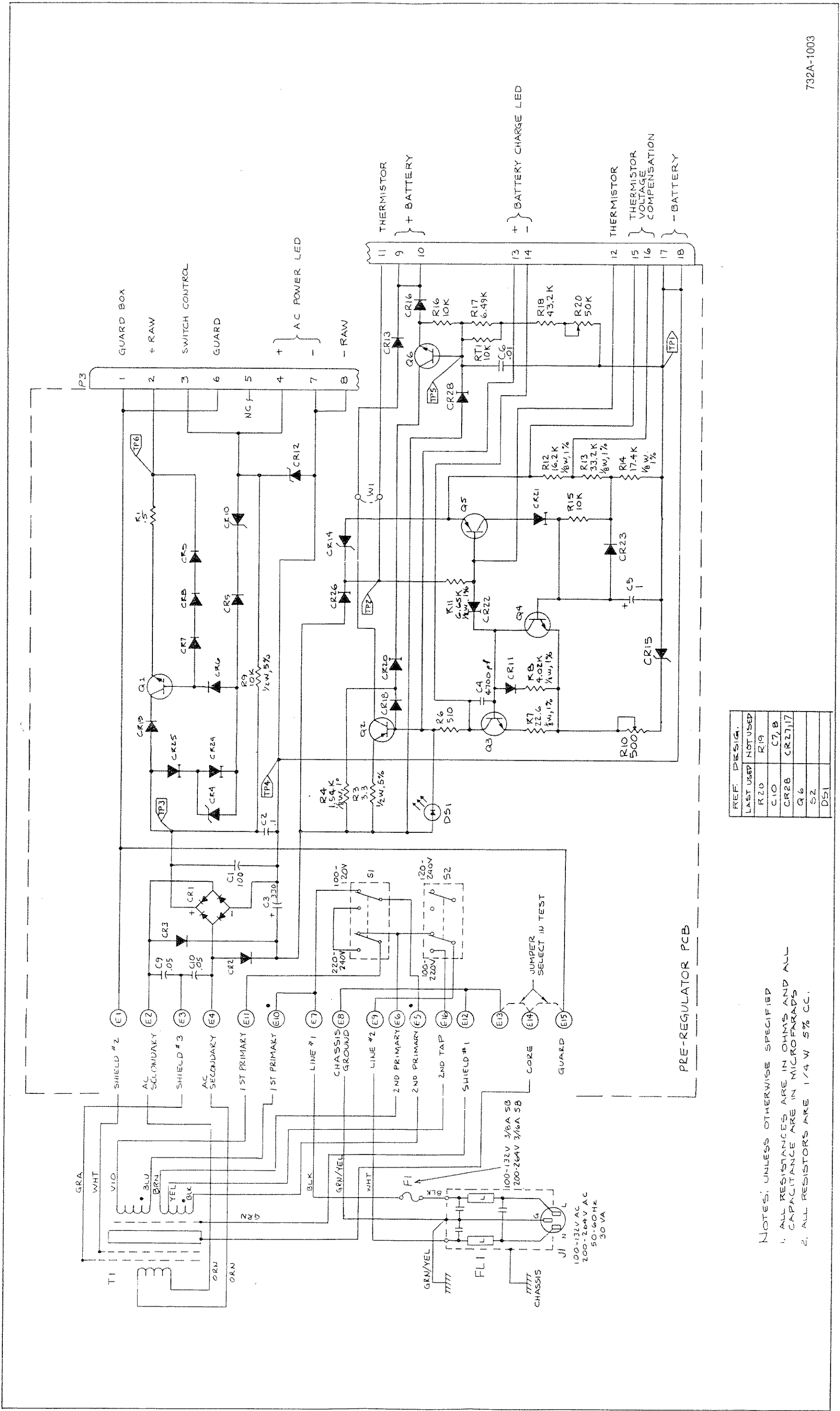

Figure 8-3. A3 Pre-Regulator PCB Assembly



732A-1003

Figure 8-3. A3 Pre-Regulator PCB Assembly (cont)

REF. DESIG.	LAST USED	NOT USED
R20	R19	
C10	C7, B	
CR28	CR27, 17	
Q6	S2	
S2	D51	

NOTES: UNLESS OTHERWISE SPECIFIED
 1. ALL RESISTANCES ARE IN OHMS AND ALL CAPACITANCE ARE IN MICROFARADS
 2. ALL RESISTORS ARE 1/4 W 5% CC.

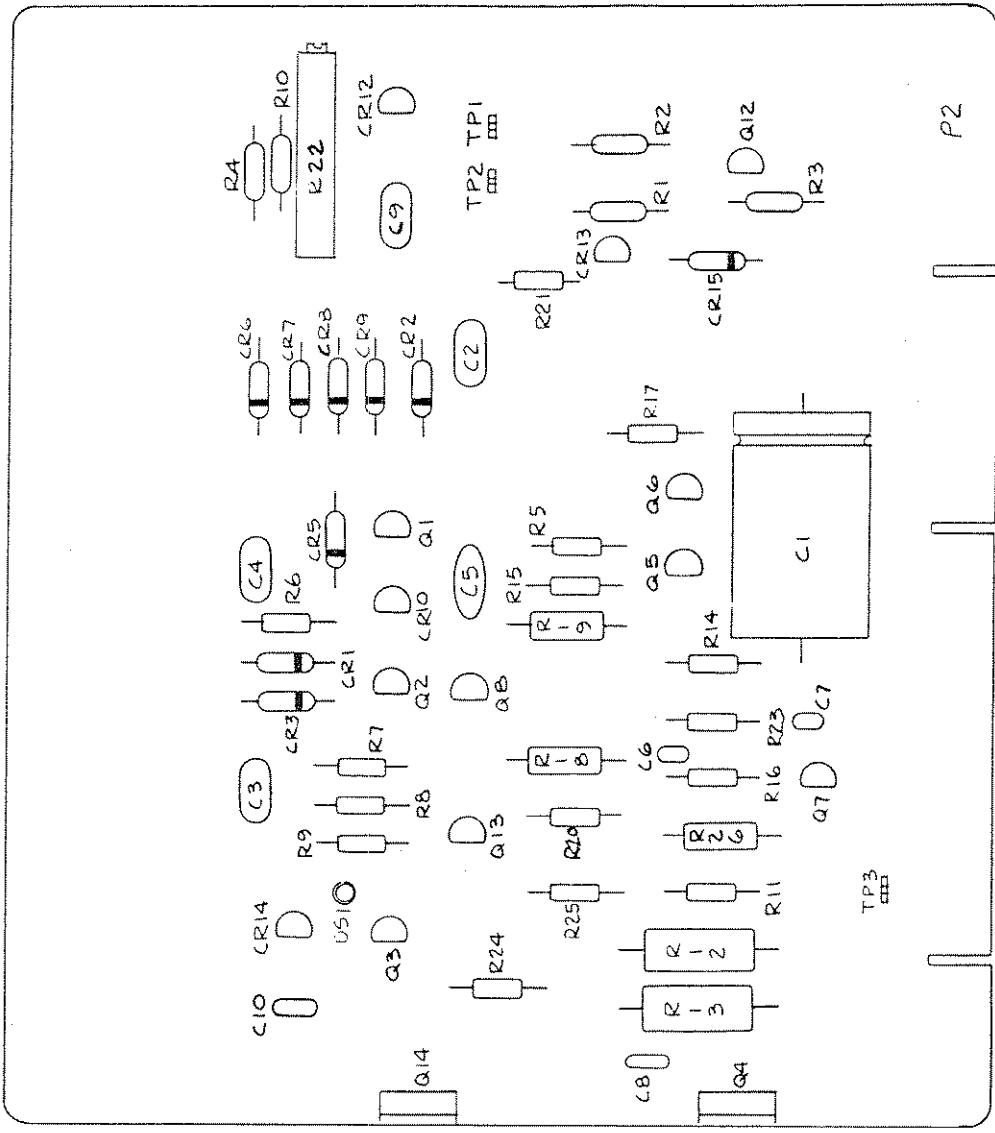
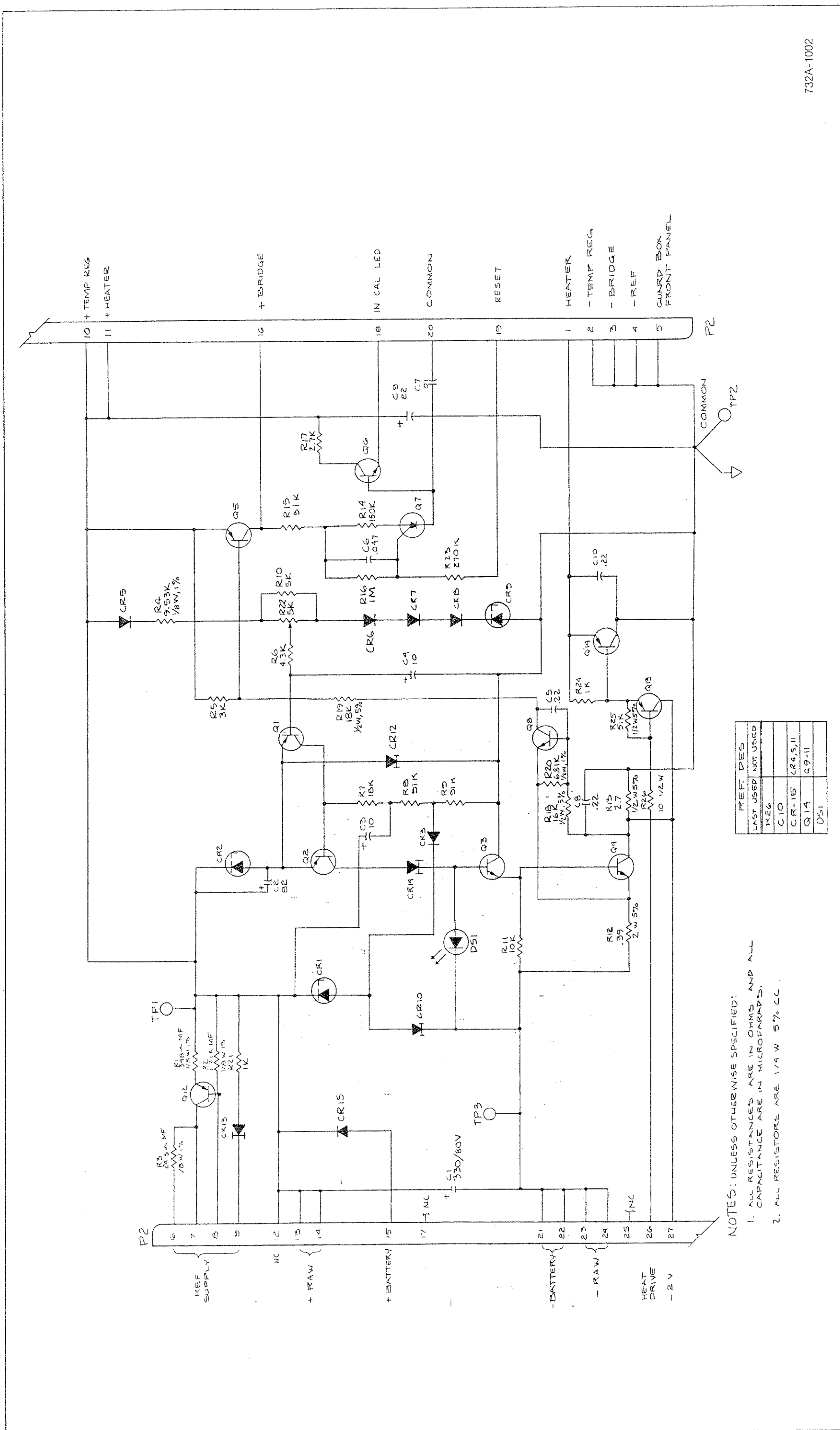

Figure 8-4. A4 Regulator PCB Assembly



REF. DES	LAST USED	NOT USED
REG		
C10		
CR-15	CR4,5,11	
Q14	Q9-11	
D51		

NOTES: UNLESS OTHERWISE SPECIFIED:
 1. ALL RESISTANCES ARE IN OHMS AND ALL CAPACITANCE ARE IN MICROFARADS.
 2. ALL RESISTORS ARE 1/4 W 5% CC.

Figure 8-4. A4 Regulator PCB Assembly (cont)

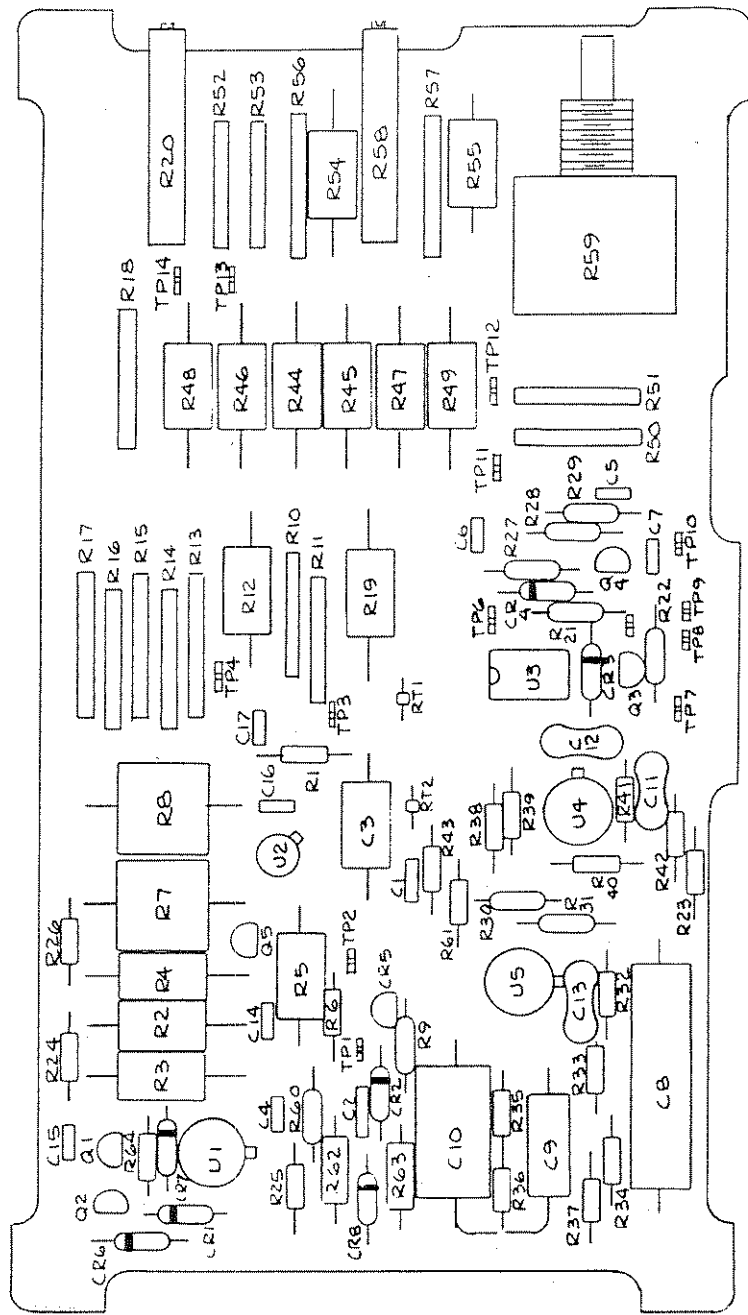
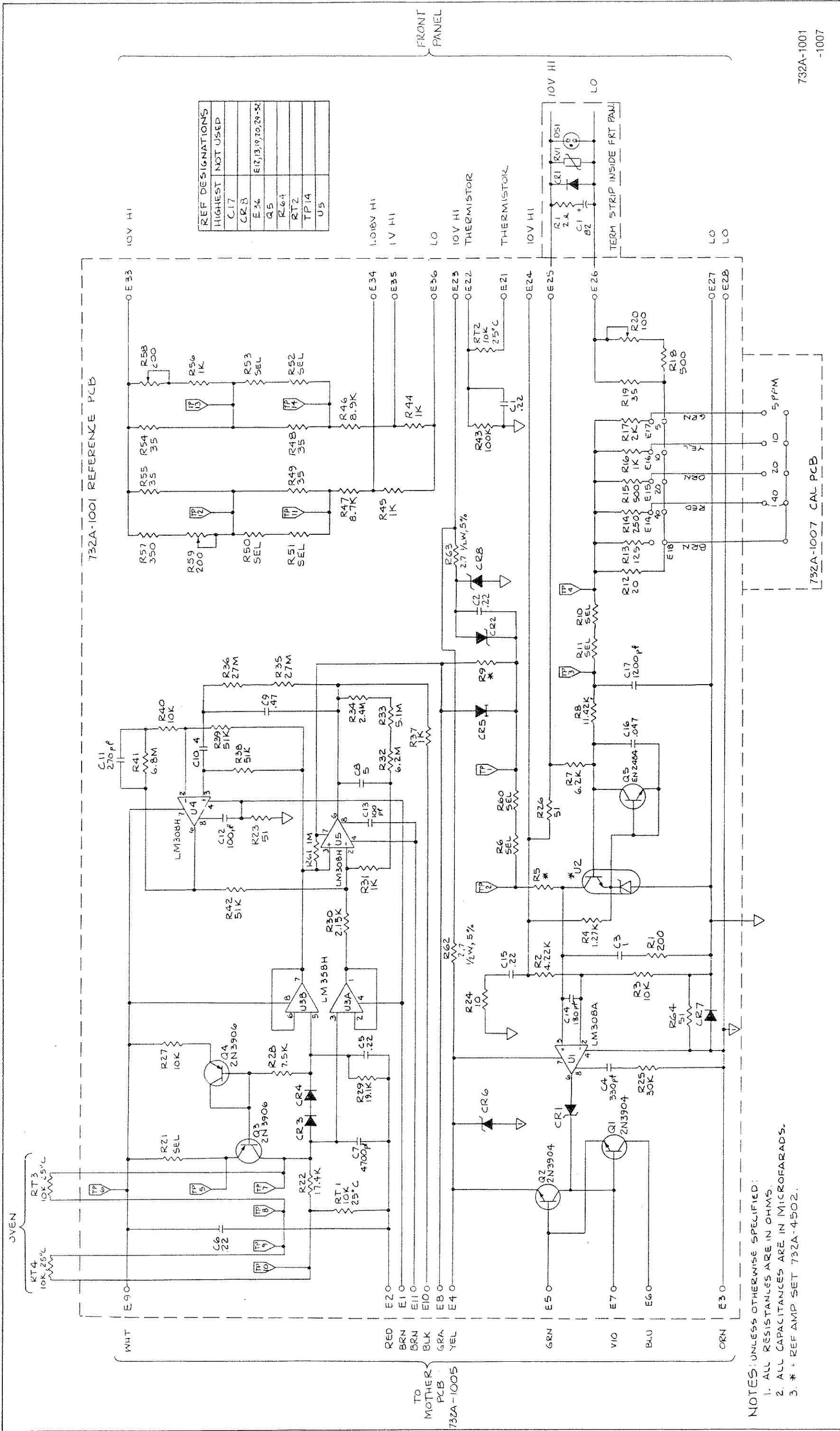

Figure 8-5. A5 Reference PCB Assembly



NOTES: UNLESS OTHERWISE SPECIFIED:
 1. ALL RESISTANCES ARE IN OHMS.
 2. ALL CAPACITANCES ARE IN MICROFARADS.
 3. * - REF AMP SET 732A-4502.

Figure 8-5. A5 Reference PCB Assembly (cont)

INDEX

The number following each index entry indicates the page number.

- Access Procedure,4-1
- Acceptance Test Procedure,4-8
- AC Line Voltage Selection,4-6
- Accessories,2-4, 6-1
- Backup Operating Power,2-5
- Battery,
 - Charge Duration,1-1
 - Charging,2-5
 - External,1-1
 - Internal,3-1
 - Charger Adjustments,4-14
 - Damage,2-5
 - Life,2-5
 - Pack Option,6-1
- Calibration,4-8
- Cleaning,4-6
- Error Sources,2-6
- Lead Wire,2-7
- Output Impedance,2-7
- Minimizing,2-6
- Thermal,2-6
- External Symptom Troubleshooting,4-16
- Fluke Address,2-1
- Front and Rear Panel Features, 2-1
- Fuse Replacement,2-1
- Guarded Operation,2-5
- Input Power Requirements,2-1
- Installation,2-1
- Internal Voltage Measurements,4-16
- Long Term Stability,2-7
- Output Short Recovery,1-1
- Oven Temperature Thermistor Nominal Value,2-6
- Rack-Mounting (see installation)
- Service,4-1
- Service Centers,7-1
- Shipping Information,2-1
- Specifications,1-1, 1-2, 1-3
- Stability (see long term stability)
- Supply Power,1-1
- Temperature Range,1-1
- Transit Case Option,6-1
- Transportation,2-1
- Troubleshooting,4-14