

FLUKE®

5520A

Multi-Product

Operators Guide

PN 688754

February 1998 Rev. 1, 4/98

© 1998 Fluke Corporation, Inc. All rights reserved. Printed in USA.

All product names are trademarks of their respective companies

www.valuetronics.com

Contents

What is in this Guide?	3
Safety Information	3
How to Contact Fluke	7
Unpacking and Inspecting	7
Replacing the Fuse	8
Selecting Line Voltage	10
Connecting to Line Power	10
Cooling Considerations	11
Front Panel	12
Rear Panel	18
Turning on the Calibrator	21
Warming up the Calibrator	22
Using the Softkeys	23
Using the Setup Menu	23
Instrument Setup Menu	24
Utility Functions Menu	25
Format EEPROM Menu	25
Zeroing the Calibrator	29
Operate and Standby	30
Connecting the Calibrator to a UUT	30
Using the EARTH and EXGRD Keys	31
Earth	31
External Guard	32
Four-Wire and Two-Wire Connections	33
Four-Wire Connection	33
Two-Wire Compensation	33
Compensation Off	33
Cable Connection Diagrams	33
RMS Versus p-p Waveforms	38
Auto Range Versus Locked Range	38
Setting Outputs	39
DC Voltage Output	39
AC Voltage Output	40
DC Current Output	42
AC Current Output	43
DC Power Output	45
AC Power Output	47

Dual DC Voltage Output	51
Dual AC Voltage Output.....	53
Resistance Output	57
Capacitance Output	59
Temperature Simulation (TC).....	60
Temperature Simulation (RTD)	63
Measuring a Thermocouple Output.....	65
Measuring Pressure	68
Waveforms.....	72
Sinewave (sine)	72
Trianglewave (tri).....	72
Squarewave (square).....	73
Truncated Sinewave (truncs)	73
Setting Harmonics.....	74
Adjusting the Phase	75
Setting a Phase Angle	77
Setting a Power Factor	77
Setting a DC Offset	78
Editing and Error Output Settings.....	79
Editing the Output Setting.....	80
Displaying the Output Error.....	80
Multiplying and Dividing	81
Setting Voltage and Current Limits	81
Synchronizing the Calibrator using 10 MHz IN/OUT	82
Using an External 10 MHz Clock.....	83
Sourcing Current with Parallel-Connected 5520As.....	84
Performance Verification	85
Internal Fuses.....	86

What is in this Guide?

The *5520A Operator Guide* is a condensation of information in the *5520A Operators Manual* (PN 688739). For complete descriptions of the Calibrator's features, functions, and operating procedures, refer to the *Operators Manual*.

Safety Information



The Calibrator can supply lethal voltages. Read this guide before operating the Calibrator.

This Calibrator complies with IEC publication 1010-1 (1992-1), Safety Requirements for Electrical Measuring, Control and Laboratory Equipment, and ANSI/ISA-S82.01-1994, and CAN/CSA-C22.2 No. 1010.1-92. This manual contains information, warnings, and cautions that must be followed to ensure safe operation and to maintain the Calibrator in a safe condition. Use of this Calibrator in a manner not specified herein may impair the protection provided by the Calibrator.

This Calibrator is designed for IEC 1010-1 Installation Category II use. It is not designed for connection to circuits rated over 4800 VA.

Warning statements identify conditions or practices that could result in personal injury or loss of life.

Caution statements identify conditions or practices that could result in damage to equipment.

Safety Information (cont)

Symbols



Warning. Risk of electric shock. Refer to the manual for information.



Chassis (earth) ground terminal.



Attention. Refer to the manual for information about this feature. This symbol appears on the rear panel CHASSIS GROUND terminal and by the fuse compartment.

AC Power Source

The Calibrator is intended to operate from an ac power source that will not apply more than 264V ac rms between the supply conductors or between either supply conductor and ground. A protective ground connection by way of the grounding conductor in the power cord is required for safe operation.

Use the Proper Fuse

To avoid fire hazard, use only the specified replacement fuse:

- For 100 V or 120 V operation, use a 5 A/250 V time delay fuse (Fluke PN 109215).
- For 200 V or 240 V operation, use a 2.5 A/250 V time delay fuse (Fluke PN 851931).

Safety Information (cont)

Grounding the Calibrator

The Calibrator uses controlled overvoltage techniques that require the Calibrator to be grounded whenever normal mode or common mode ac voltages or transient voltages may occur. The enclosure must be grounded through the grounding conductor of the power cord, or through the rear panel CHASSIS GROUND binding post.

Use the Proper Power Cord

Use only the power cord and connector appropriate for the voltage and plug configuration in your country.

Use only a power cord that is in good condition.

Refer power cord and connector changes to qualified service personnel.

Do Not Operate in Explosive Atmospheres

To avoid explosion, do not operate the Calibrator in an atmosphere of explosive gas.

Check Insulation Ratings

Verify that the voltage applied to the unit under test does not exceed the insulation rating of the UUT and the interconnecting cables.

Safety Information (cont)

Do Not Remove Cover During Operation

To avoid personal injury or death, do not remove the Calibrator cover without first removing the power source connected to the rear panel. Do not operate the Calibrator without the cover properly installed. Normal calibration is accomplished with the cover closed. Access procedures and the warnings for such procedures are contained in the *5520A Service Manual*. Service procedures are for qualified service personnel only.

Do Not Attempt to Operate if Protection May Be Impaired

If the Calibrator appears damaged or operates abnormally, protection may be impaired. Do not attempt to operate the Calibrator under these conditions. Refer all questions of proper Calibrator operation to qualified service personnel.

How to Contact Fluke

To order accessories, receive operating assistance, or get the location of the nearest Fluke distributor or Service Center, call:

1-800-44FLUKE (1-800-443-5853) in U.S.A. and Canada

+31-402-678-200 in Europe

+81-3-3434-0181 Japan

+65-^{*}-276-6196 Singapore

+1-425-356-5500 from other countries

Address correspondence to:

Fluke Corporation
P.O. Box 9090,
Everett, WA 98206-9090
USA

Fluke Europe B.V.
P.O. Box 1186,
5602 BD Eindhoven
The Netherlands

Visit us on the World Wide Web at: www.fluke.com

Unpacking and Inspecting

The Calibrator is shipped in a container designed to prevent damage. Inspect the Calibrator carefully for damage and immediately report any damage to the shipper. Instructions are included in the shipping container.

When you unpack the Calibrator, determine if your order is complete. Standard equipment is listed in the next table. Report any shortage to the place of purchase or to the nearest Fluke Technical Service Center.

If reshipping the Calibrator, use the original container. If it is not available, you can order a new container from Fluke by indicating the Calibrator's model and serial number.

Standard Equipment

Item	Number
Calibrator	5520A
Line Power Cord	*
<i>5520A Operators Manual (English)</i>	688739
<i>5520A Programmers Guide (English)</i>	688744
<i>5520A Operators Guide (English)</i>	688754
<i>5520A Operators Guide (French)</i>	688751
<i>5520A Operators Guide (Italian)</i>	
<i>5520A Operators Guide (German)</i>	688762
<i>5520A Operators Guide (Spanish)</i>	688769
<i>5520A Operators Guide (Japanese)</i>	688770
<i>5520A Operators Guide (Simplified Chinese)</i>	688777
Certificate of Calibration	—
*See Chapter 2 of the <i>5520A Operator's Manual</i> for available types	

Replacing the Fuse



To avoid damage to the Calibrator, verify that the correct fuse is installed for the selected line voltage. For 100 V and 120 V, use 5 A/250 V time delay; for 200 V and 240 V, use 2.5 A/250 V time delay.

Disconnect line power. To replace the fuse, refer to the following figure.

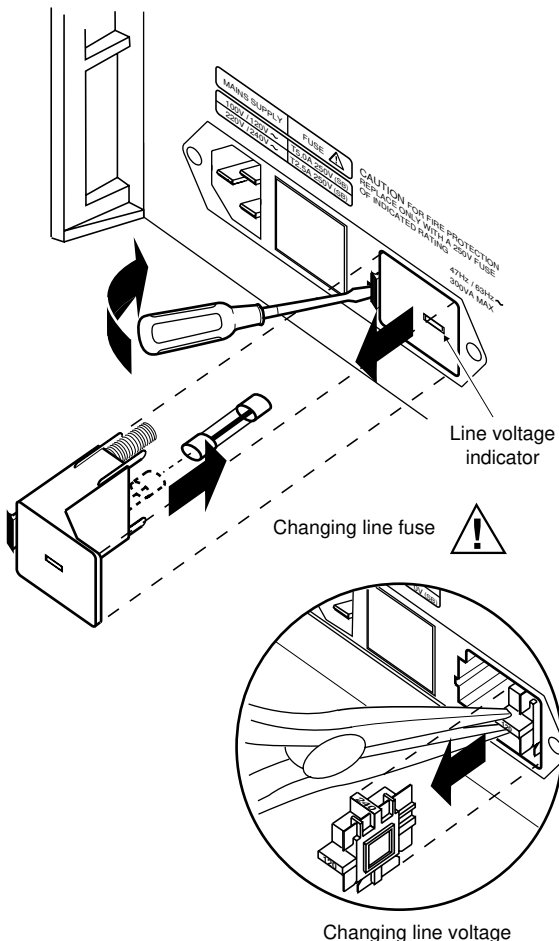

oe01f.eps

Selecting Line Voltage

There are four line voltage settings: 100 V, 120 V, 200 V, and 240 V (47 to 63 Hz). To check the setting, note the voltage visible through the window of the fuse compartment cover. To change the line voltage setting, see the figure above.

Connecting to Line Power



To avoid shock hazard, connect the factory supplied, three-conductor power cord to a properly grounded power outlet. Do not use a two-conductor adapter or extension cord; this will break the protective ground connection.

Use the rear-panel ground terminal for a protective grounding wire if there is any question as to instrument earth grounding.

The Calibrator comes with the line power plug appropriate for the country to which it is shipped. If you need a different plug, refer to Chapter 2 of the *5520A Operators Manual* for a list and illustrations of available plugs.

After you verify that the line voltage is set correctly and that the correct fuse is installed, connect the Calibrator to a properly grounded three-prong outlet.

Cooling Considerations

Warning

To avoid risk of injury, never operate or power the Calibrator without the fan filter in place.

Caution

Damage caused by overheating may occur if the area around the air intake is restricted, the intake air is too warm, or the air filter becomes clogged.

The accuracy and dependability of the internal parts of the Calibrator are enhanced by maintaining the coolest possible internal temperature. To lengthen the life of the Calibrator and enhance its performance:

- The air filter must be at least 3 inches from nearby walls or rack enclosures.
- The exhaust perforations on the sides of the Calibrator must be clear of obstructions.
- The air entering the Calibrator must be at room temperature: make sure the exhaust air from another Calibrator is not directed into the fan inlet.
- Clean the air filter every 30 days, or more frequently if the Calibrator is operated in a dusty environment.

Front Panel

The front panel provides all controls, displays, indicators, and terminals.

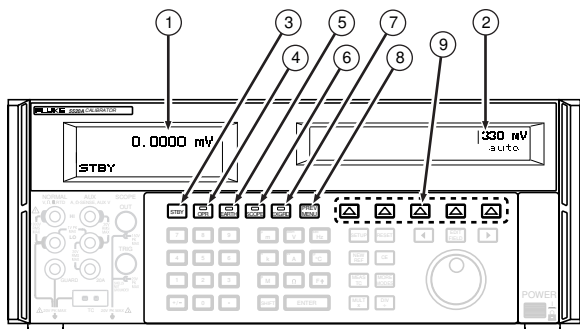

oe02f.eps

① Output Display

Two-line, backlit LCD showing output amplitudes, frequency and Calibrator status.

② Control Display

Multipurpose backlit LCD for displaying data entries, UUT error adjustments, softkey labels, phase angles, watts, power factors, and other prompts and messages.

③

Places the Calibrator in the standby mode. The NORMAL, AUX, and 20A output terminals are internally disconnected from the Calibrator.

Front Panel (cont)

④ **OPR**

Places the Calibrator in the operate mode and lights the indicator on the key.

⑤ **EARTH**

Opens and closes a connection between the NORMAL LO terminal and earth ground. When the indicator is lit, the connection is closed.

⑥ **SCOPE**

Activates or deactivates an oscilloscope calibration option if one is installed. An indicator on the key indicates when the option is activated.

⑦ **EXGRD**

Opens and closes an internal connection between the internal NORMAL LO signal ground and the internal guard shield. When the indicator is lit, the connection is open.

⑧ **PREV
MENU**

Recalls the previous set of menu choices. Each press of this key backs up one level of the menu tree.

⑨ **Softkeys**

Softkeys are identified by labels on the Control Display directly above each key.

Front Panel (cont)

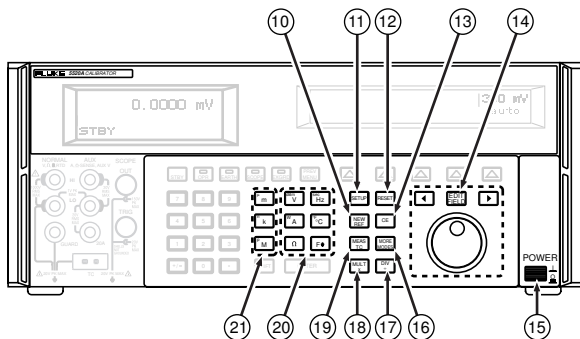

oe03f.eps

10 NEW REF

During error mode operation, establishes the present output value as a new reference for meter error computation.

11 SETUP

Displays the setup menu in the control display. Setup options can be selected using the softkeys.

12 RESET

Aborts the current operating state of the 5520A and returns it to the power-up default state, except during remote control.

13 CE

Clears a partially completed keypad entry from the Control Display.

Front Panel (cont)



Provides step adjustments of the magnitude of the output signal.

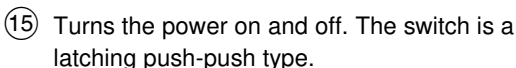

Selects the pressure measurement function.



Changes the output to 1/10 the reference value (not necessarily the present output value).



Changes the output to 10x the reference value (not necessarily the present output value).



Enables the thermocouple (TC) input connection and causes the 5520A to compute a temperature based on the input.

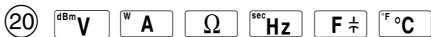

Select the Calibrator function. Some keys select a second function using .

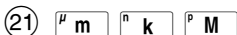

Select output value multipliers. Some keys select an alternate multiplier using .

Front Panel (cont)

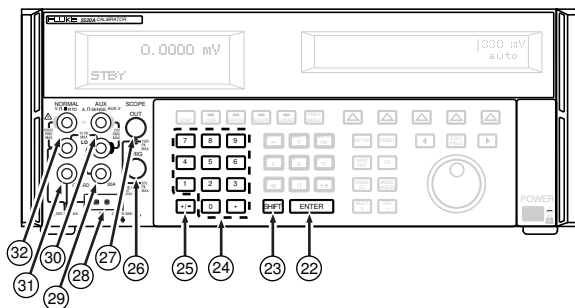

oe04f.eps

22 ENTER

Loads a newly entered output value shown on the Control Display into the Calibrator, which appears on the Output Display.

23 SHIFT

Selects alternate functions of the units keys and alternate multipliers of the multiplier keys.

24 Numeric Keypad

Used to enter the digits of the output amplitude and frequency

25 +/-

Changes the polarity of the output for dc voltage or dc current functions.

26 SCOPE TRIG

The output connector for triggering an oscilloscope during oscilloscope calibration.

Front Panel (cont)

②⑦ SCOPE OUT

The output connector for oscilloscope calibration.

②⑧ TC

The input/output jack for thermocouple simulation during temperature meter calibration, and thermocouple measurements.

②⑨ 20A

The high terminal for sourcing the high current range (3A to 20A).

③⑩ AUX

The source of ac and dc current outputs, the second voltage output in dual voltage modes, and ohms sense for two-wire and four-wire compensated resistance and capacitance measurements, and RTD simulation.

③① GUARD

Always internally connected to the internal guard shield. See ⑦ .

③② NORMAL

The source of ac and dc voltage, ohms and capacitance outputs, and Resistance Temperature Detector (RTD) simulation.

Rear Panel

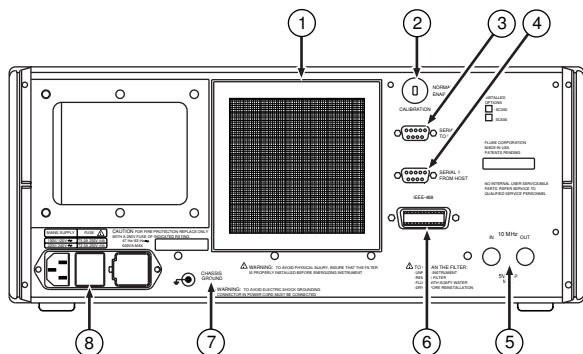

o305f.eps

① The fan filter covers the air intake to keep dust and debris out of the chassis air baffles.

② **CALIBRATION NORMAL/ENABLE**

Switch that enables or disables the ability to write to the nonvolatile memory that stores calibration constants.

③ **SERIAL 2 TO UUT**

Connector used for transmitting/receiving serial data between the Calibrator and a Unit Under Test (UUT). This is also the connector for Fluke 700 Series Pressure Modules.

④ **SERIAL 1 FROM HOST**

Connector used for remote control of the Calibrator with a host, printer, or terminal.

Rear Panel (cont)

⑤ 10 MHz IN

Connector for applying an optional external clock signal to the 5520A. This replaces the normal internal 10 MHz clock signal in the 5520A. Frequency accuracy of the 5520A is governed by the frequency accuracy of the clock signal internal or external.

10 MHz OUT

Connector that passes the internal or external 10 MHz clock signal to another 5520A to synchronize one or more slave 5520As to a master 5520A.

⑥ IEEE-488

Standard parallel interface for operating the Calibrator in remote control on the IEEE-488 bus.

Rear Panel (cont)

7

Warning

To avoid shock hazard, connect the factory supplied three-conductor line power cord to a properly grounded power outlet. Do not use a two-conductor adapter or extension cord; this will break the protective ground connection.

Use the rear-panel ground terminal for a protective grounding wire if there is any question as to Calibrator earth grounding.

CHASSIS GROUND



Internally grounded to the chassis.

8 **AC Power Input Module**

Provides a grounded three-prong connector that accepts the line power cord, a switch mechanism to select the operating line voltage, and a line power fuse.

Turning on the Calibrator

Warning

The Calibrator is capable of supplying lethal voltages. Do not make connections to the output terminals when any voltage is present. Placing the Calibrator in standby may not be enough to avoid shock hazard, since the  key could be pressed accidentally. Press the  key and verify that the Calibrator is in standby before making connections to the output terminals.

Warning

To avoid electric shock, make sure the Calibrator is safely grounded as described in “Connecting to Line Power.”

Caution

Before turning the Calibrator on, make sure that the line voltage selection is set properly. Refer to “Selecting Line Voltage.”

When the Calibrator is powered up, it displays “Starting Up...” (see below) and it completes a self-test routine. If a self-test fails, the Control Display identifies an error code.

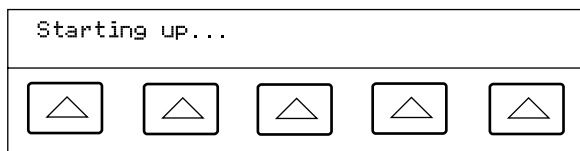

oe06f.eps

After self-test, the Control Display shows the reset condition (below).

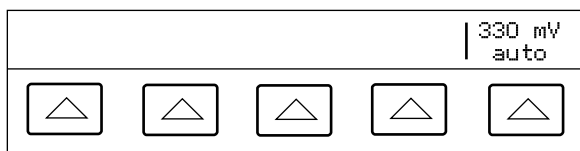

auto
locked

oe07f.eps

Warming up the Calibrator

Allow the Calibrator to warm-up for at least 30 minutes after you turn it on. This allows the internal components to stabilize.

If you turn the Calibrator off after warm-up and then on again, allow a warm-up period of at least twice the length of time it was turned off (maximum of 30 minutes). For example, if the Calibrator is turned off for 10 minutes and then on again, allow a warm-up period of at least 20 minutes.

Using the Softkeys

The five keys to the right of the **PREV MENU** (previous menu) key are softkeys. A “softkey” is an unlabeled key that accesses a menu or menu tree with multiply functions and operations.

A softkey’s functional or operational status is shown directly above it on the Control Display. Pressing a softkey either changes a value or causes a submenu with new selections to appear on the Control Display.

To back up to a previous menu selection, press **PREV MENU**. Although pressing **RESET** will return you to the top level menu, it will also reset all volatile settings and return the Calibrator to 0V dc in the standby mode. Use the **PREV MENU** key as your main navigating tool for moving around the menu levels.

Using the Setup Menu

Press **SETUP** to access operations and changeable parameters.

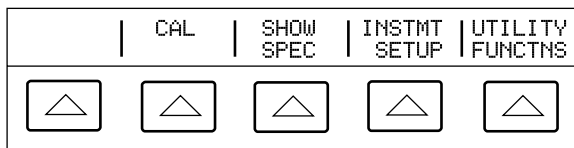

oe08f.eps

Instrument Setup Menu

Press INSTMT SETUP in the setup menu to open the instrument setup menu.

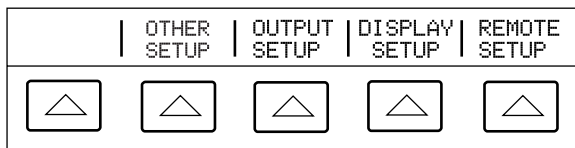

oe09f.eps

OTHER SETUP opens a menu to select the temperature standard, set the clock, and change the power-up defaults for displayed error units and safety timeout period for an oscilloscope option test.

OUTPUT SETUP opens a menu to change the power-up defaults for current and voltage limits, thermocouple and RTD types, the phase reference, internal or external phase reference source, impedance for dBm display, and pressure units.

DISPLAY SETUP opens submenus to adjust the brightness and contrast of both the Control Display and Output Display.

REMOTE SETUP opens menus to configure the two serial ports and the IEEE488 port.

Utility Functions Menu

Press UTILITY FUNCTNS in the setup menu to open the utility menus.

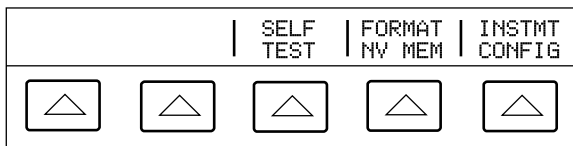

oe10f.eps

SELF TEST opens a menu with Calibrator self-test choices.

FORMAT NV MEM (format nonvolatile memory) opens a menu to restore all or part of the data in the nonvolatile memory (EEPROM) to factory defaults.

INSTMT CONFIG (instrument configuration) allows you to view the versions of software installed in the Calibrator as well as the user-entered report string.

Format EEPROM Menu



Caution

Use with extreme care! The FORMAT NV MEM (format nonvolatile memory) softkeys permanently erase calibration constants. Pressing ALL or CAL invalidates the state of calibration of the 5520A.

Press **FORMAT NV MEM** in the utility functions menu to open the following menu:



oe11f.eps

ALL replaces the contents of the EEPROM with factory defaults. The rear panel CALIBRATION switch must be in the ENABLE position.

CAL replaces all calibration constants with factory defaults. The rear panel CALIBRATION switch must be in the ENABLE position.

SETUP replaces the setup parameters with factory defaults (see the Factory Defaults table on the next page).

Factory Defaults

User report string (RPT_STR string)	cleared
Error units	>0.1%
SC-600 option overload test safety timeout	10 seconds
Temperature standard	its-90
Host interface	gpib (IEEE-488)
UUT serial interface	8 bits, 1 stop bit, xon/xoff, parity none, 9600 baud
Host serial interface	term, 8 bits, 1 stop bit, xon/xoff, parity none, 9600 baud, CRLF, 012,000
GPIB Port Address	4
Display brightness (Note)	level 1,0
Display contrast (Note)	level 7,7
dBm impedance	600Ω
Pressure units	psi
RTD type	pt385

Factory Defaults (cont)

Thermocouple type	K
Phase reference	0.00 degrees
10 MHz reference clock	internal
Current limits	± 20.5 A
Voltage Limits	± 1000 V
Remote Command Defaults	
SRQSTR	SRQ: %02x %02x %04x %04x
*PUD string	cleared
Note: Output Display and Control Display, respectively. There are 8 levels: 0,1,2,3,4,5,6,7.	

Zeroing the Calibrator

To meet specifications, zero the Calibrator every 7 days, or when the Calibrator ambient temperature changes by more than 5 °C. Choose from complete Calibrator zeroing (ZERO) or ohms-only zeroing (OHMS ZERO). For the tightest ohms specifications, zero the ohms function every 12 hours, or whenever the ambient temperature has changed more than ± 1 °C.

1. Turn on the Calibrator and warmup (30 minutes).
2. Press **RESET**.
3. Press **SETUP**, opening the setup menu.

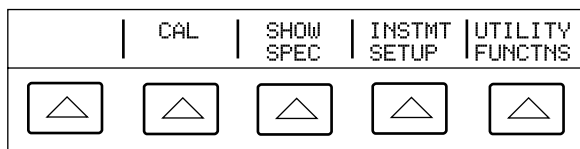

oe12f.eps

5. Press CAL in the setup menu.

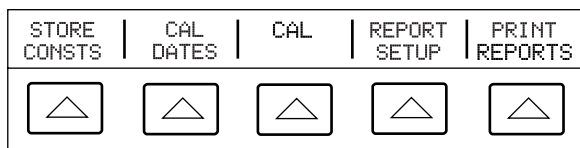

oe13f.eps

6. Press CAL in the calibration menu.

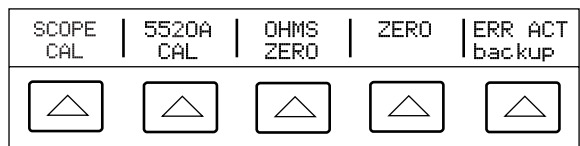

oe14f.eps

7. Press ZERO for complete Calibrator zeroing or OHMS ZERO for ohms-only zeroing. After zeroing routine is complete (several minutes), press **RESET**.

Operate and Standby

To enable the operate mode, press **OPR**. To place the Calibrator in standby, press **STBY**.

The Calibrator goes into the standby if:

- The **RESET** key is pressed.
- A voltage $\geq 33V$ is selected when the previous output voltage was $< 33V$.
- The function changed.
- The output location changed between the AUX and 20A terminals.
- An overload condition is detected.

Connecting the Calibrator to a UUT



The Calibrator is capable of supplying lethal voltages. Do not make connections to the output terminals when a voltage is present. Placing the Calibrator in standby may not be enough to avoid shock hazard, since the **OPR key could be pressed accidentally. Press **RESET** and verify that the STBY annunciator appears on the Control Display before making connections to the output terminals.**

Using the EARTH and EXGRD Keys

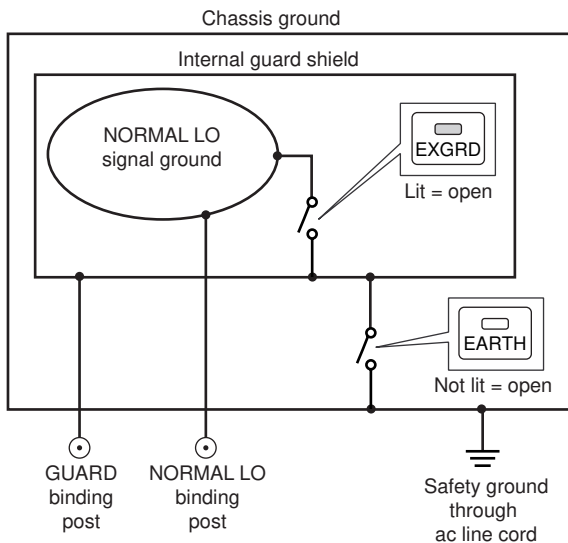

oe15f.eps

Earth

The 5520A Calibrator front panel NORMAL LO terminal is normally isolated from earth (chassis) ground. When it is desired to make a connection between the NORMAL LO terminal and earth ground, press the **EARTH** key, lighting the key indicator.

To avoid ground loops and noise you must have only one earth ground-to-LO terminal connection in the system. Usually you make all signal ground connections at the UUT and verify the **EARTH** annunciator is off. Generally, **EARTH** is on only for ac and dc volts where the UUT is isolated from earth ground. There must, however, be a safety ground for the 5520A. See “Connecting to Line Power” in Chapter 2. When enabled by the sourced output, a softkey LOs appears, which allows you to tie or open an internal connection between the NORMAL LO terminal and AUX LO terminal. When tied and **EARTH** is on, then both LO terminals are tied to chassis ground.

External Guard

The guard is an electrical shield, isolated from the chassis, that protects the analog circuitry. The guard provides a low-impedance path for common-mode noise and ground loop currents. There is normally an internal connection between the guard and the NORMAL LO terminal. By pressing the **EXGRD** key, you break this internal connection, which allows you to connect a lead from the GUARD terminal to earth ground on another instrument in an interconnected system. Use this external guard connection whenever you are testing a UUT that has a grounded LO terminal. Remember to always maintain only one earth ground tie point in a system.

Four-Wire and Two-Wire Connections

Four-Wire Connection

The four-wire connection is typical for calibrating laboratory measurement equipment, providing increased precision for resistance values below 110 k Ω . For other values, the lead resistances do not degrade the accuracy, so the Calibrator changes the compensation to off (COMP off).

Two-Wire Compensation

The two-wire connection is typical for calibrating precision handheld digital multimeters (DMMs) with a two-wire input. Increased precision is provided for resistance values below 110 k Ω and capacitance values 110 nF and above. For other values, the Calibrator changes the compensation to off (COMP off).

Compensation Off

Compensation off is a typical connection for calibrating handheld analog meters or DMMs with a two-wire input. This connection is used for all values of resistance and capacitance and is usually selected when the analog meter or DMM level of accuracy does not require the additional precision. This is the default condition whenever an ohms or capacitance output is made, following an output that was not ohms or capacitance.

Cable Connection Diagrams

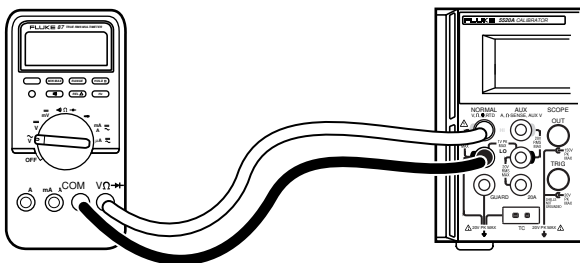

DC Voltage/AC Voltage

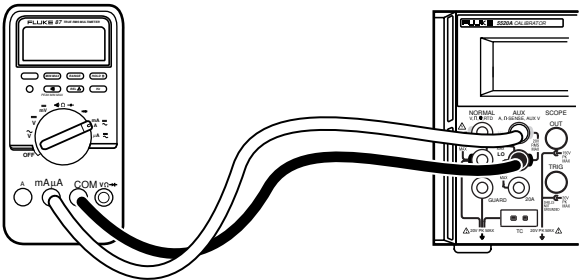

DC Current/AC Current

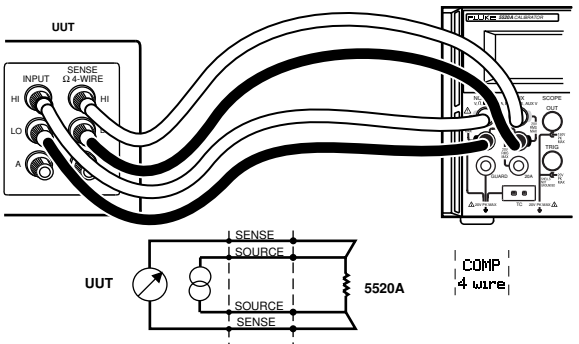

Ohms (4-Wire Comp)

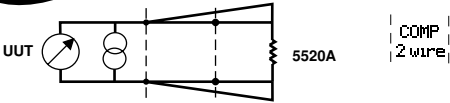
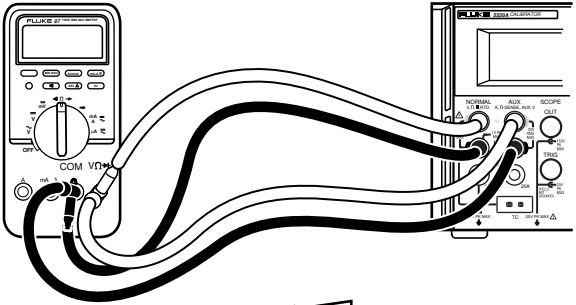

oe19f.eps

Ohms (2-Wire Comp)

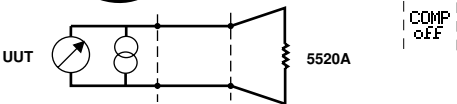
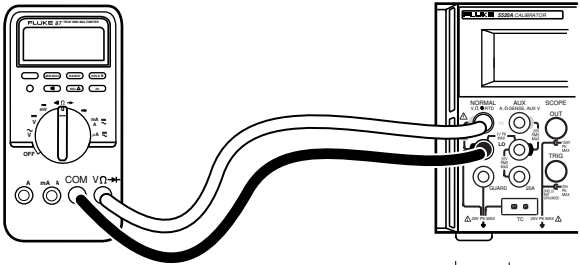

oe20f.eps

Ohms (Comp Off)

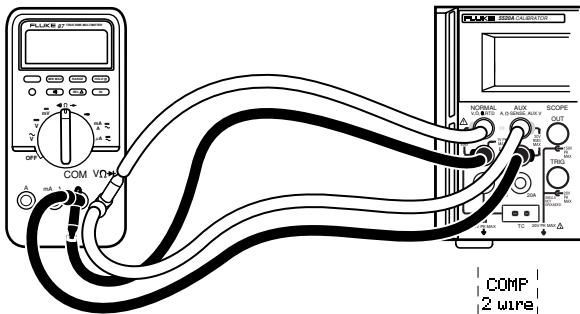

oe21f.eps

Capacitance (2-Wire Comp)

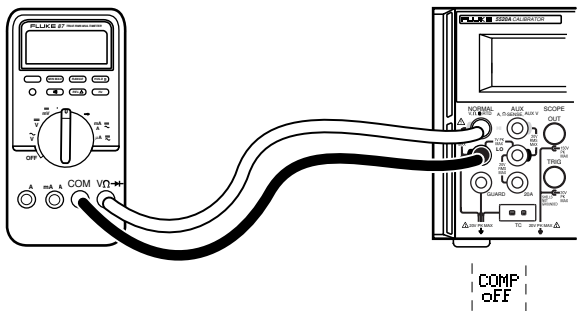

oe22f.eps

Capacitance (Comp Off)

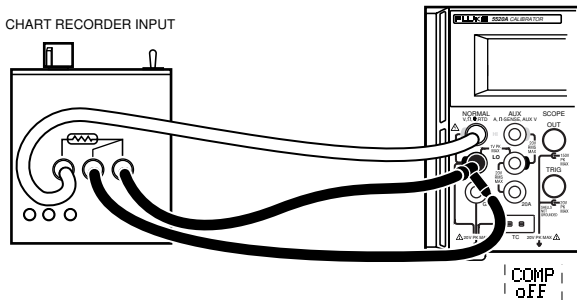

oe24f.eps

Temperature (RTD)

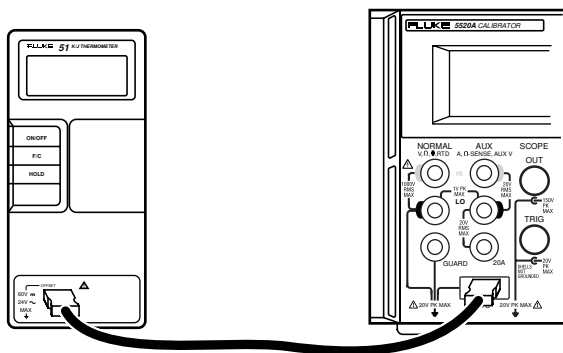

oe25f.eps

Temperature (Thermocouple)

RMS Versus p-p Waveforms

Sinewave outputs are in rms, while the trianglewave, squarewave, and truncated sinewave outputs are in p-p. The relationship between p-p and rms for the non-sinewave types are as follows:

- **Squarewave** p-p x 0.5000000 = rms
- **Trianglewave** p-p x 0.2886751 = rms
- **Truncated Sinewave** p-p x 0.2165063 = rms

Auto Range Versus Locked Range

A softkey is provided to toggle between the ranging method auto or locked. This feature is available only for single-output dc volts and dc current outputs.

When auto is selected (the default setting), the Calibrator automatically selects the range that provides the best output resolution. When locked is selected, the Calibrator locks the selected range and will not change ranges when you are editing the output, or entering new outputs. Locked range is usually made when you do not want range changes that may cause a small perturbation in the output, e.g., when checking the linearity of a given multimeter range.

Setting Outputs

DC Voltage Output

To set a dc voltage output at the Calibrator NORMAL terminals:

1. Press **RESET** to clear the Calibrator output.
2. Connect to the UUT.
3. Set the UUT to measure dc voltage.
4. Enter the desired voltage output (up to 7 digits).
5. Press **+/-** to select polarity.
6. Press a multiplier key, if necessary.
7. Press **10^{-6} V**.
8. The Control Display shows entered value. For example, 123.4567 mV.

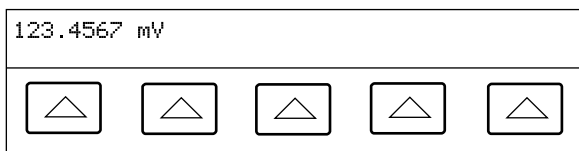

oe26f.eps

9. Press **ENTER**. The output value appears on the Output Display.

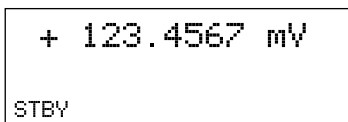

oe27f.eps

10. Press **OPR** to activate the Calibrator output.
11. Press the **auto/locked** softkey to toggle between autorange mode or lock the Calibrator in the present range.

AC Voltage Output

To set ac voltage output in volts or as a power output in dBm (referenced to a selectable load impedance) at the Calibrator NORMAL terminals:

1. Press **RESET** to clear the Calibrator output.
2. Connect to the UUT.
3. Set the UUT to measure ac voltage.
4. Enter the desired voltage output (up to 6 digits).
5. Press a multiplier key, if necessary.
6. Press **^{dBm}V** (volts) or **SHIFT ^{dBm}V** (dBm).

If you are using dBm, a softkey appears that lets you choose an impedance value from a list.

7. Control Display shows entered value. For example, 2.44949 V.

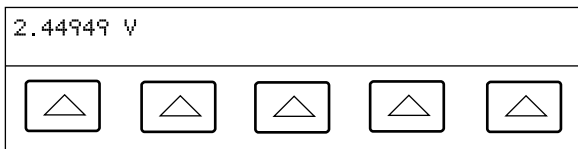

oe28f.eps

8. Enter the desired frequency output (up to 5 digits).
9. Press a multiplier key, if necessary.
10. Press **^{sec}Hz**.
11. The Control Display shows entered value. For example, 1.1234 kHz (below).

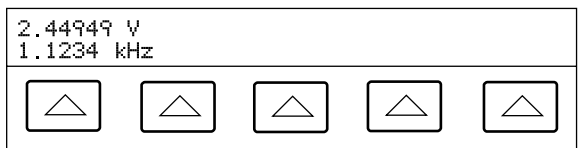





oe29f.eps

12. Press **ENTER**. The Output Display changes to:

2.44949 V		
STBY	1123.4	Hz

oe30f.eps

13. Press **OPR** to activate the Calibrator output.

DUTY 50.00	OFFSET +0.00000 V	ϕ & REF MENUS	WAVE square
			
1.00 to 99.00%	See specifications.		sine tri square truncs

oe31f.eps

DUTY (Duty Cycle) sets the squarewave duty cycle (1.00 to 99.00%).

OFFSET (Voltage Offset) adds positive or negative dc offset voltage.

ϕ & REF MENUS opens a menu to control the phase relationship between the output and that of a master 5520A synchronized using the **10 MHz IN** input.

WAVE (waveform) selects one of four different types of waveforms.

DC Current Output

To set dc a current output at the Calibrator AUX or 20A terminals:

1. Press **RESET** to clear the Calibrator output.
2. Connect to the UUT.
3. Set the UUT to measure dc current.
4. Enter the desired current output (up to 6 digits).
5. Press **+/-** to select polarity.
6. Press a multiplier key, if necessary.
7. Press **^wA**.
8. Control Display shows entered value. For example, 234.567 mA.

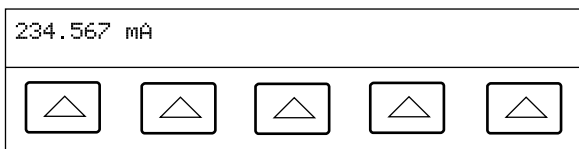

oe32f.eps

9. Press **ENTER**.

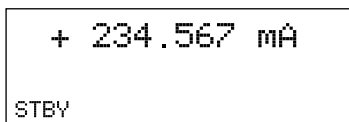

oe33f.eps

10. Press **OPR** to activate the Calibrator output.

OUTPUT selects the AUX or 20A terminals. Outputs 3A or above are always on the 20A terminals.

Press the **auto/locked** softkey to toggle between autorange mode or lock the Calibrator in the present range.

AC Current Output

To set an ac current output at Calibrator AUX or 20A terminals:

1. Press **RESET** to clear the Calibrator output.
2. Connect to the UUT.
3. Set the UUT to measure ac current.
4. Enter the desired current output (up to 6 digits).
5. Press a multiplier key, if necessary.
6. Press **^WA**.
7. Enter the desired frequency (up to 5 digits).
8. Press a multiplier key, if necessary.
9. Press **^{SEC}Hz**.
10. The Control Display shows the entered value.
For example, 123.456 mA and 1.1234 kHz.

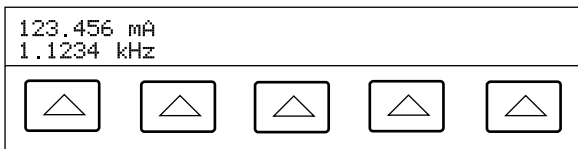

oe34f.eps

11. Press **ENTER**.

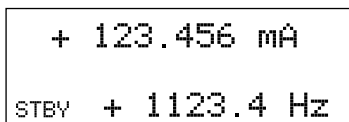

oe35f.eps

10. Press **OPR** to activate the Calibrator output.

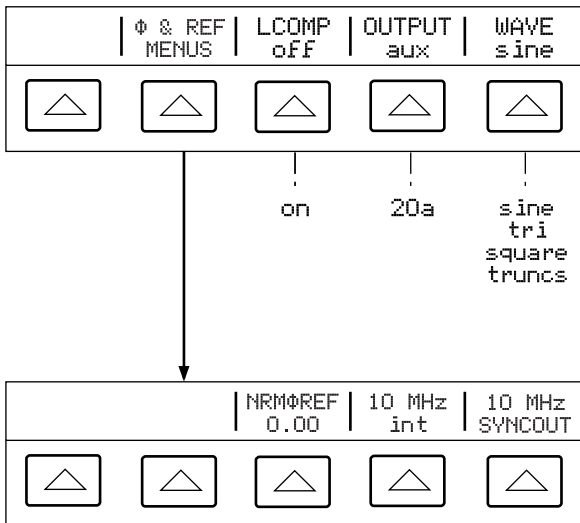

oe79f.eps

ϕ & REF MENU opens a menu to control a phase relationship between the output and that of a master 5520A synchronized using the **10 MHz IN** input.

LCOMP turns inductive compensation on and off. Inductive compensation is available for frequencies up to 1 kHz at outputs up to 239.999 mA, and for frequencies up to 440 Hz above 239.999 mA.

OUTPUT shows whether the output is on the AUX or 20A terminals. Outputs 3A or above are always on the 20A terminals.

WAVE (waveform) selects one of four different types of waveforms.

DC Power Output

Note

Tie the NORMAL LO and AUX LO terminals together at the UUT or at the Calibrator, via the “LO”s “tied” softkey.

To set dc a voltage at Calibrator NORMAL terminals and a dc current on AUX or 20A terminals:

1. Press **RESET** to clear the Calibrator output.
2. Connect to the UUT.
3. Set the UUT to measure dc power.
4. Enter the desired voltage output (up to 7 digits).
5. Press **+/-** to select polarity.
6. Press a multiplier key, if necessary.
7. Press **^{dBm}V** .
8. Enter the desired current output (up to 6 digits).
9. Press **+/-** to select polarity.
10. Press a multiplier key, if necessary.
11. Press **^WA** .

12. The Control Display shows entered value. For example, 123.4567 mV and 234.567 mA.

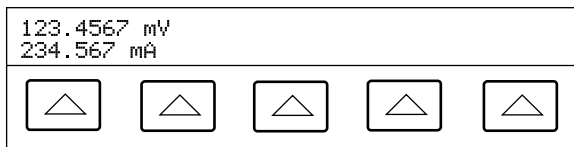

oe36f.eps

13. Press .

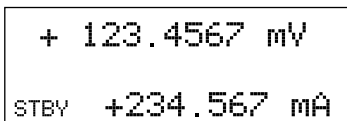

oe37f.eps

14. Press to activate the Calibrator output.

(Enter voltage *or* current and then a watts entry value using . The remaining volts or current value is calculated and displayed.)

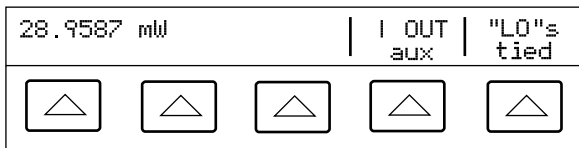

oe80f.eps

I OUT selects AUX or 20A terminals. Current outputs 3A or above are always on the 20A terminals.

"LO"s ties or opens a connection between front panel NORMAL LO and AUX LO terminals.

AC Power Output

Note

Tie the NORMAL LO and AUX LO terminals together at the UUT or at the Calibrator, via the "LO"s "tied" softkey. For optimum phase performance, tie the LO terminals at the UUT. At current levels ± 2.2 A, tie the terminals at the UUT using heavy gage wire < 10 m Ω resistance.

To set ac voltage at Calibrator NORMAL terminals and ac current on AUX or 20A terminals:

1. Press **RESET** to clear the Calibrator output.
2. Connect to the UUT.
3. Set the UUT to measure ac power.
4. Enter the desired voltage output (up to 6 digits).
5. Press a multiplier key, if necessary.
6. Press **^{dBm}V**.
7. Enter the desired current output (up to 6 digits).
8. Press a multiplier key, if necessary.
9. Press **^WA**.
10. Enter the desired frequency output (up to 5 digits).

11. Press a multiplier key, if necessary.
12. Press **^{sec}Hz** .
13. Control Display shows entered value. For example, 123.456 mV, 234.567 mA, and 1.1234 kHz.

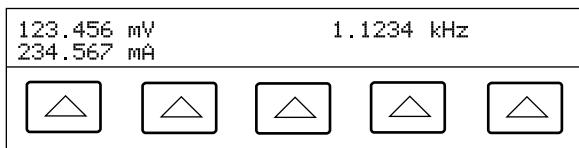

oe38f.eps

14. Press **ENTER** .

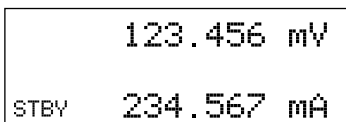

oe39f.eps

15. Press **$\overline{\text{OPR}}$** to activate the Calibrator output.

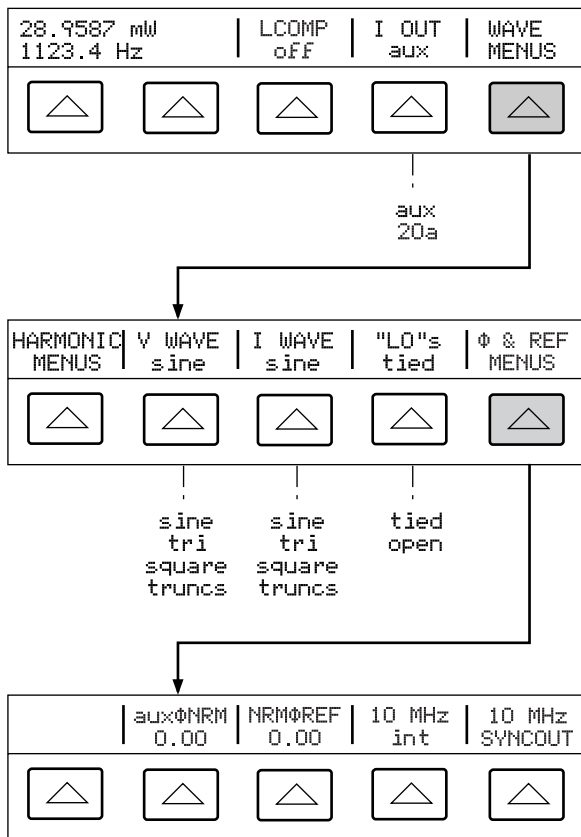

oe40f.eps

(Enter voltage *or* current and then a watts value using **SHIFT** **W A**. The remaining volts or current value is calculated and displayed.)

LCOMP turns inductive compensation on and off. Inductive compensation is available for frequencies up to 1 kHz at outputs up to 239.999 mA, and for frequencies up to 440 Hz above 239.999 mA.

I OUT shows whether the current output is on the AUX or 20A terminals. Outputs 3A or above are always on the 20A terminals.

WAVE MENU selects type of harmonic, waveform, front panel LO terminal condition, and phase.

HARMONIC MENU selects harmonic outputs.

V WAVE selects voltage waveform.

I WAVE selects current waveform.

“LO”s ties or opens a connection between front panel NORMAL LO and AUX LO terminals.

φ & REF MENU opens a menu to control a phase relationship between the output and that of a master 5520A synchronized using the **10 MHz IN** input, and a phase difference between NORMAL and AUX outputs.

Dual DC Voltage Output

Note

Tie the NORMAL LO and AUX LO terminals together at the UUT or at the Calibrator, via the "LO"s "tied" softkey.

To set dual dc voltages at Calibrator NORMAL and AUX terminals:

1. Press **RESET** to clear the Calibrator output.
2. Connect to the UUT.
3. Set the UUT to measure dual dc voltage.
4. Enter the desired voltage output at NORMAL terminals (up to 7 digits).
5. Press **+/-** to select polarity.
6. Press a multiplier key, if necessary.
7. Press **dBmV**.

Note

Voltage on the AUX output is limited to 3.3V.

8. Enter the desired voltage output at AUX terminals (up to 6 digits).
9. Press **+/-** to select polarity.
10. Press a multiplier key, if necessary.
11. Press **dBmV**.
12. The Control Display shows entries. For example, 123.4567 mV and 234.567 mV.

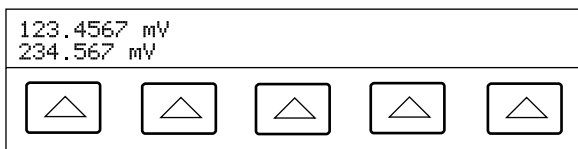

oe41f.eps

13. Press .

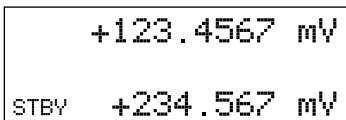

+123.4567 mV
STBY +234.567 mV

14. Press to activate the Calibrator output.

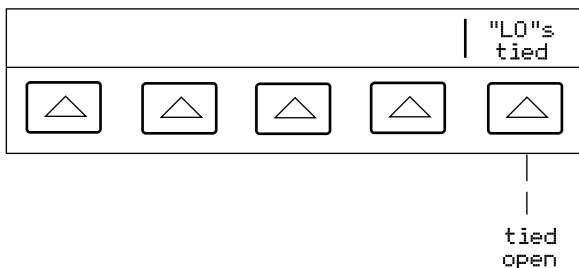

oe43f.eps

“**LO**”s ties or opens a connection between front panel NORMAL LO and AUX LO terminals.

Dual AC Voltage Output

Note

Tie the NORMAL LO and AUX LO terminals together at the UUT or at the Calibrator, via the "LO"s tied softkey.

Selecting voltage in units of dBm is not allowed in dual ac voltage mode. To set dual ac voltages at Calibrator NORMAL and AUX terminals:

1. Press to clear the Calibrator output.
2. Connect to the UUT.
3. Set the UUT to measure dual ac voltage.
4. Enter the desired voltage output at NORMAL terminals (up to 6 digits).
5. Press a multiplier key, if necessary. For example, press .
6. Press .

Note

The AUX output is limited to 5 V rms for sinewaves, 14 V p-p for squarewaves, triangle and truncated sinewaves.

7. Enter the desired voltage output at AUX terminals (up to 6 digits).
8. Press a multiplier key, if necessary.
9. Press .
10. Enter the desired frequency output (up to 5 digits).

11. Press a multiplier key, if necessary.

12. Press .

13. The Control Display shows entries. For example, 123.456 mV, 234.567 mV at 1.1234 kHz.

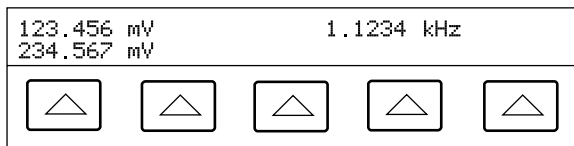

oe44f.eps

14. Press .

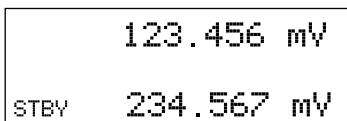

oe45f.eps

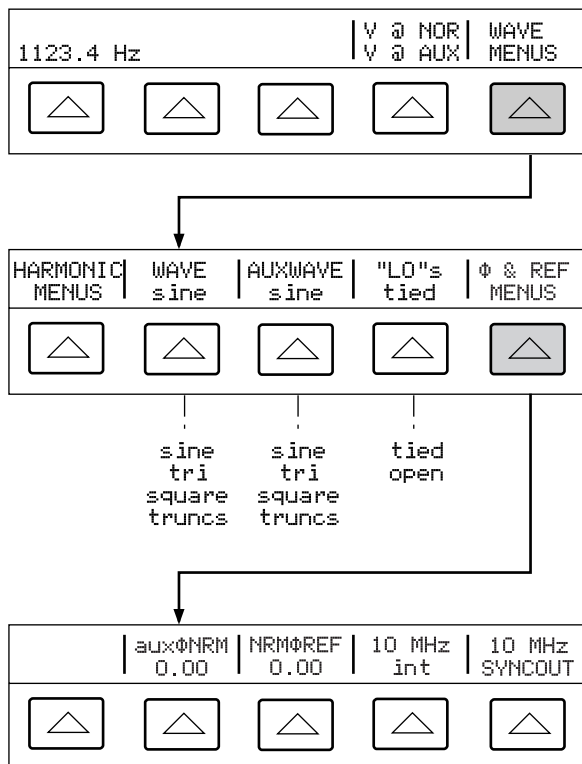

oe46f.eps

V @ NOR, V@ AUX

Shows that the function is dual voltage.

WAVE MENU selects the type of harmonic, waveform, front panel LO terminal condition, and phase.

HARMONIC MENU selects harmonic outputs.

WAVE selects the waveform for the NORMAL terminals.

AUXWAVE selects the waveform for the AUX terminals.

“LO”s ties or opens a connection between front panel NORMAL LO and AUX LO terminals.

ϕ & **REF MENU** opens a menu to control a phase relationship between the output and that of a master 5520A synchronized using the **10 MHz IN** input, and a phase difference between NORMAL and AUX outputs.

Resistance Output

To set synthesized resistance output at Calibrator NORMAL terminals:

1. Press **RESET** to clear the Calibrator output.
2. Connect to the UUT.

Note

Terminal connections from Calibrator to UUT must be LO to LO and HI to HI.

3. Set the UUT to measure resistance.
4. Enter the desired resistance (up to 6 digits).
5. Press a multiplier key, if necessary.
6. Press **Ω**.
7. Control Display shows entered value. For example, 12.3456 kΩ.

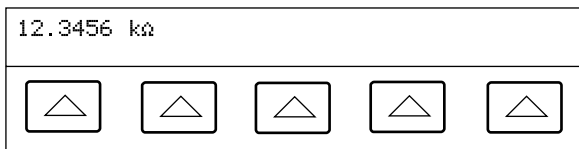

oe47f.eps

8. Press **ENTER**.

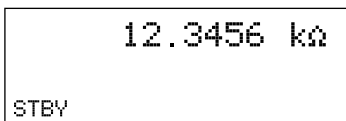

oe48f.eps

9. Press **OPR** to activate the Calibrator output.

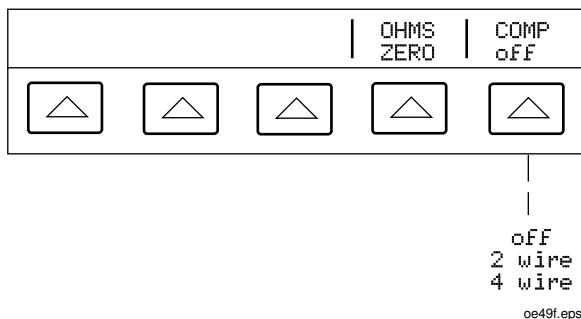

OHMS ZERO press to remove offsets in the internal circuitry for the ohms function. Allow several minutes.

COMP for <110 k Ω only, applies four-wire, two-wire or compensation off.

Capacitance Output

To set synthesized capacitance output at Calibrator NORMAL terminals:

1. Press **RESET** to clear the Calibrator output.
2. Connect to the UUT.

Note

Since this is a synthesized output, the terminal connections from the Calibrator to the UUT must be LO to LO and HI to HI.

3. Set the UUT to measure capacitance.
4. Enter the desired capacitance output (up to 5 digits).
5. Press a multiplier key. For example, **SHIFT** then **μ m** for μ F.
6. Press **F $\frac{1}{2}$** .
7. Control Display shows entered value. For example, 123.45 μ F (below).

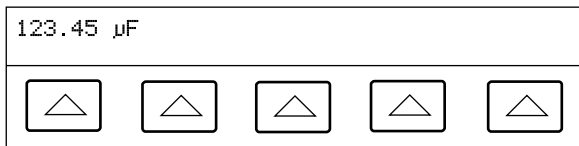

oe50f.eps

8. Press **ENTER**.

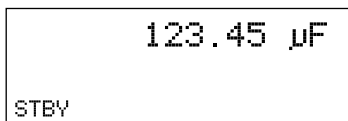

oe51f.eps

9. Press **OPR** to activate the Calibrator output.

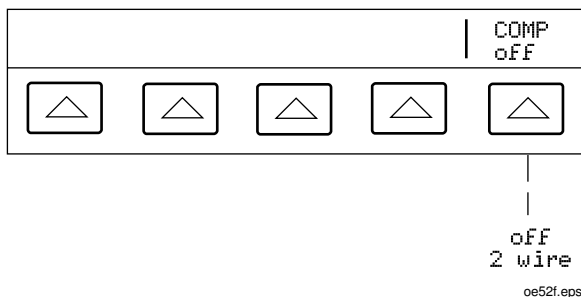

COMP (Compensation) applies two-wire compensation or turns compensation off for capacitance of 110 nF and above. This feature cancels out lead resistance, NOT capacitance.

Temperature Simulation (TC)

Note

Make sure the thermocouple wire and plug are not affected by extraneous temperature sources. For example, do not place your fingers on the thermocouple plug or wire when simulating a thermocouple.

To set a simulated thermocouple temperature output at Calibrator front panel TC connector:

1. Press **RESET** to clear the Calibrator output.
2. Connect to the UUT.

Note

Use thermocouple wire and miniconnectors that match the type of thermocouple.

3. Set the UUT to measure temperature.
4. Enter the desired temperature output (up to 6 digits).
5. Press the **F°C** key for °C, or **SHIFT F°C** for °F.

6. The Control Display shows the entered value.
For example, 123.456 °C.

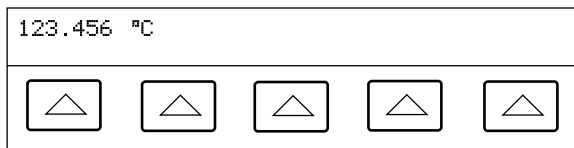

oe53f.eps

7. Press .

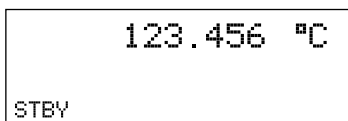

oe54f.eps

8. Press to activate the Calibrator output.

Note

The temperature is cleared to 0°C (32°F) if you change between tc and rtd, or change the type of thermocouple (except a B-type thermocouple, which starts at 600 °C).

Out@ TC terminal = 50.0900 mV	TC MENUS	OUTPUT tc	TYPE K

rtd
tc

N
R
S
T
L:Jdin
U:Tdin
10µV/°C
1mV/°C
B
C
E
J

UNITS °C	REF SRC intrnl	REF NONE	TYPE K

°C
°F

intrnl
extrnl

-250 to
2316 °C

N
R
S
T
L:Jdin
U:Tdin
10µV/°C
1mV/°C
B
C
E
J

oe55f.eps

Out@TC terminal displays dc voltage at TC terminals.

TC MENUS opens submenus for thermocouple outputs.

OUTPUT selects the temperature device: thermocouple (tc) or resistance temperature detector (rtd).

TYPE selects the thermocouple type to simulate.

UNITS selects °C or °F temperature unit.

REF SRC selects intrnl (Internal) or extrnl (External) reference source.

REF shows the value of the temperature reference.

TYPE selects the thermocouple type to simulate.

Temperature Simulation (RTD)

To set a simulated RTD temperature output at Calibrator NORMAL terminals:

1. Press **RESET** to clear the Calibrator output.
2. Connect to the UUT.
3. Set the UUT to measure temperature.
4. Enter the desired temperature output (up to 6 digits).
5. Press the **°C** key for °C, or **SHIFT** **°C** for °F.
6. Control Display shows entered value. For example, 123.456 °C.

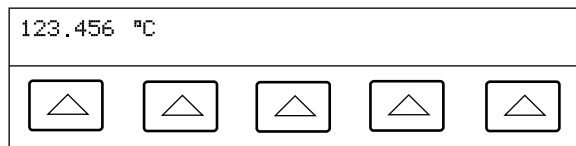

oe53f.eps

7. Press **ENTER**.





```
123.456 °C
STBY
```

oe54f.eps

8. Press **OPR** to activate the Calibrator output.

Note

The temperature is cleared to 0 °C (32 °F) if you change between tc and rtd, or change the type of rtd.

OUT @ NORMAL	TYPE	OUTPUT	COMP
= 100.000 Ω	pt385	rtd	off
			
	200Ω385 500Ω385 1kΩ385 pt3916 pt3926 ni120 cu10	rtd tc	off 2 wire 4 wire

oe58f.eps

Output @ NORMAL displays location of output terminals (always NORMAL).

TYPE selects rtd curve.

OUTPUT selects temperature device: thermocouple (tc) or resistance temperature detector (rtd).

COMP applies four-wire compensation, two-wire compensation or turns compensation off. For a 3-wire RTD configuration, turn compensation off.

Measuring a Thermocouple Output

To measure the output of a thermocouple connected to the Calibrator TC connector:

1. Press **RESET** to clear the Calibrator output.
2. Connect a thermocouple to TC connector.

Note

Use thermocouple wire and miniconnectors that match the type of thermocouple.

3. Press **MEAS
TC** to display the TC menus.

Meas@TC terminal = ----- V	TC MENUS	OFFSET 0.00	TYPE K

-500 to
=500 °C

N
R
S
T
L: Jdin
U: Tdin
10µV/°C
1mV/%RH
1mV/°C
B
C
E
J

OpenTCD on	UNITS °C	REF SRC intrnl	REF 27.75	TYPE K

on
off

°C
°F

intrnl
extrnl

-250 to
2316 °C

N
R
S
T
L: Jdin
U: Tdin
10µV/°C
1mV/%RH
1mV/°C
B
C
E
J

oe59f.eps

4. The measured temperature is in Output Display. A lower-case m blinks during a measurement.

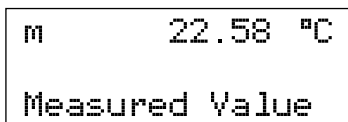

oe60f.eps

Meas@TC terminal displays dc voltage at TC terminals.

TC MENUS opens submenus supporting thermocouple outputs.

Open TCD Turns the “open thermocouple detect” feature on or off.

UNITS selects °C or °F temperature units.

REF SRC selects intrnl (internal) or extrnl (external) reference source.

REF displays value of temperature reference.

TYPE selects emulated thermocouple type.

Measuring Pressure

The 5520A can be used as a pressure Calibrator when you use it with the following accessories:

To measure pressure:

- Fluke 700-Series Pressure Module
- Model 700PCK Pressure Calibration Kit (necessary because it provides the interface module)
- Null modem adapter
- Gender changer adapter

To source pressure:

- A stable, hand-operated or automated pressure source
- Fluke 700-Series Pressure Module
- Model 700PCK Pressure Calibration Kit (necessary because it provides the interface module)
- Null modem adapter
- Gender changer adapter

The next figure shows how to connect a 700 Series Pressure Module to the 5520A.

To connect a pressure module to the 5520A and display a pressure measurement, proceed as follows:

1. Plug a Fluke 700 Series Pressure Module into the interface unit.
2. Connect the null model adapter to the SERIAL 2 TO UUT connector on the 5520A rear panel.

Note

You cannot use the SERIAL 2 TO UUT port as a pass-through port while using a pressure module.

3. Connect the gender changer adapter to the null modem adapter. Tighten the connector screws.
4. Connect the interface cable between the interface unit and the gender changer adapter.
5. Connect the interface unit to the line power adapter.
6. Plug the line power cord into line power.
7. Press the **MORE MODES** key on the 5520A. This activates pressure mode.
8. The Output Display shows the pressure value measured by the pressure module. The Control Display contains three softkeys: DAMPEN (on, off), SET OFFSET (zeros the pressure module), and UNITS (pressure units).
9. If you are using any 700 Series Pressure Module except an absolute-pressure type (Model Number starts with "700PA"), vent the pressure module to atmosphere and press the SET OFFSET softkey to zero the pressure module.

10. If you are using an absolute-pressure type module (Model Number starts with "700PA") zero the pressure module as follows:
 - a. Vent the module to atmosphere.
 - b. Press the SET OFFSET softkey.
 - c. Enter the ambient atmospheric pressure in the units currently displayed.

Note

*Do not rely on airport pressure reports.
Use a barometric pressure standard in the
same area as the Calibrator.*

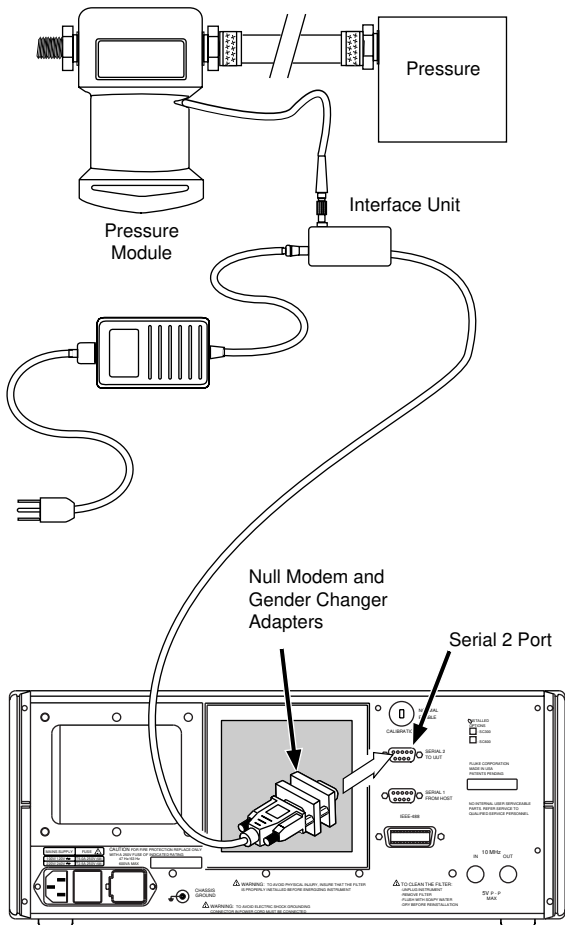

5520A Rear Panel

oe77i.eps

Waveforms

For ac voltage, ac current, dual ac voltage, and ac power, select among **sine**, **tri**, **square**, or **truncs** waveforms.

Sinewave (sine)

A sinewave is present on Calibrator outputs. Variables are amplitude, frequency, and dc offset voltage.

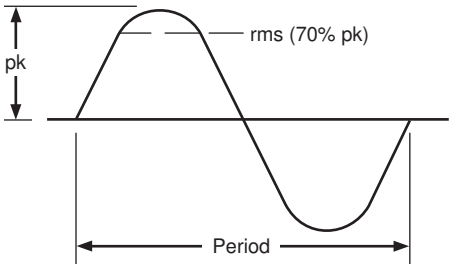

oe61f.eps

Sinewave

Trianglewave (tri)

A trianglewave is present on Calibrator outputs. Variables are amplitude, frequency, and dc offset voltage.

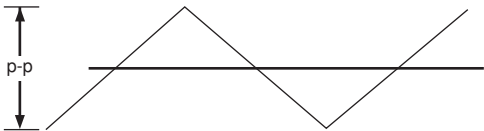

oe62f.eps

Trianglewave

Squarewave (square)

A squarewave is present on Calibrator outputs. Variables are duty cycle, amplitude, frequency, and dc offset voltage.

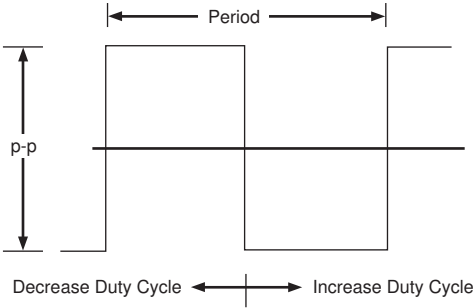

oe63f.eps

Squarewave and Duty Cycle

Truncated Sinewave (truncs)

A truncated sinewave is present on Calibrator outputs. Variables are amplitude and frequency.

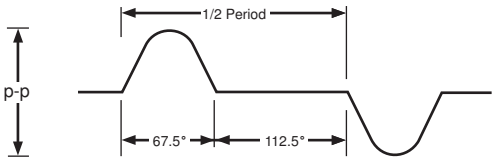

oe64f.eps

Truncated Sinewave

Setting Harmonics

To source two signals with adjustable harmonic difference for dual ac voltages or ac power (sinewaves only), perform the procedure below. Fundamentals can be configured on either NORMAL or AUX terminals.



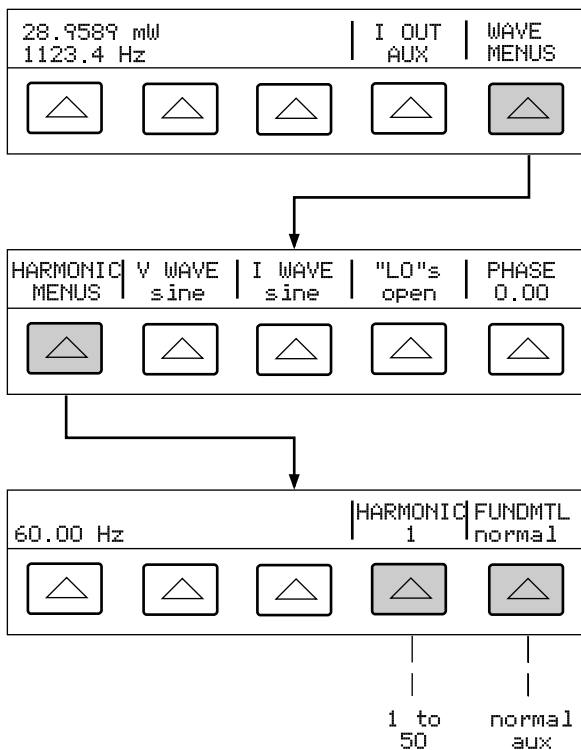

1. Press WAVE MENUS to open waveform menu.
2. Press HARMONIC MENUS to open harmonic menu.



oe65f.eps

3. Press FUNDMTL to select NORMAL or AUX terminals for fundamental.
4. Press HARMNIC to enter desired harmonic (1 to 50). For example, 7th harmonic. Press

ENTER .

Harmonic = 1 New harmonic = 7				
				

oe66f.eps

5. Press **PREV MENU** one or more times to return to previous menus.

Adjusting the Phase

To set a phase difference between outputs in dual ac voltage and ac power output modes:

28.9589 mW 1123.4 Hz	I OUT AUX	WAVE MENUS
<input type="button" value="▲"/>	<input type="button" value="▲"/>	<input type="button" value="▲"/>

HARMONIC MENUS	V WAVE sine	I WAVE sine	"LO"s open	PHASE 0.00
<input type="button" value="▲"/>	<input type="button" value="▲"/>	<input type="button" value="▲"/>	<input type="button" value="▲"/>	<input type="button" value="▲"/>

Phase = 0.00 New Phase =	SHOW PF
<input type="button" value="▲"/>	<input type="button" value="▲"/>

Power factor = 1.000 New pf =	PF lead	SHOW PHASE
<input type="button" value="▲"/>	<input type="button" value="▲"/>	<input type="button" value="▲"/>

lead
lag

oe67f.eps

Setting a Phase Angle

To set a phase shift in degrees for dual ac voltage or ac power output:

1. Press WAVE MENUS to open waveform menu.
2. Press PHASE to open phase entry menu.
3. Enter the desired phase angle (up to 5 digits).
4. Press **+/-** to select leading (+) or lagging (-) phase shift.
5. Control Display shows entries. For example, a leading phase angle of 123.45 degrees. Press **ENTER**.

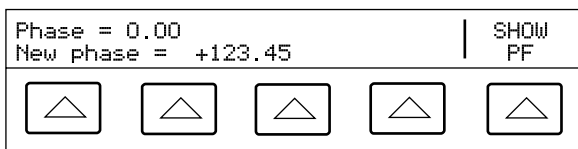

oe68f.eps

6. Press **PREV MENU** one or more times to return to previous menus.

Setting a Power Factor

To set a phase shift as a power factor (PF), where $PF = \text{Cosine } \Phi$, and Φ is phase shift:

1. Press WAVE MENUS to open waveform menu.
2. Press PHASE to open phase entry menu.
3. Press SHOW PF to open power factor entry menu.
4. Enter the desired power factor (3 digits).

5. Press PF to toggle a leading (**lead**) or lagging (**lag**) power factor. For example, a leading power factor of .678. Press .

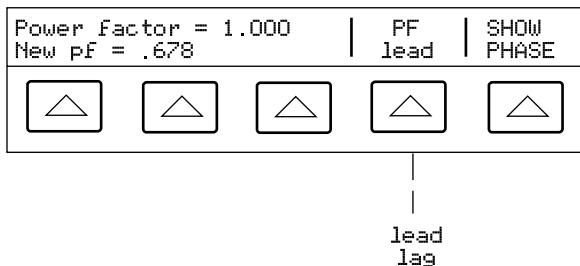

oe69f.eps

6. Press one or more times to return to previous menus.

Setting a DC Offset

To set a dc offset for single ac voltage outputs:

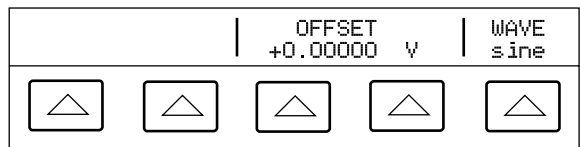

oe70f.eps

1. Press WAVE to select desired waveform.
2. Press OFFSET to open offset entry menu.
3. Enter the desired offset. For example, 0.123 V. Press .

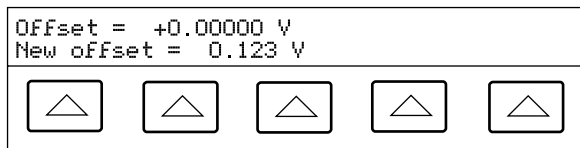

oe71f.eps

4. Press **PREV MENU** one or more times to return to previous menus.



Editing and Error Output Settings

Use the Edit Field knob and **◀**, **▶**, and **EDIT FIELD** keys to edit outputs. Multiply **MULT X** and divide **DIV ÷** keys edit output by decades.

Keys That Exit Error Mode

Keys	Action
ENTER	Returns to the previous reference value
+/- + ENTER	New reference
Keypad entry + ENTER	New reference
NEW REF	Present output as new reference
MULT X	Sets the Calibrator to x10 reference value and new reference
DIV ÷	Sets the Calibrator to 1/10 reference value and new reference
RESET	Returns to the power-up state

Editing the Output Setting

Turn the Edit Field knob clockwise to increase the output value or counter-clockwise to decrease the output value. To select a higher order digit, use the key  or . The output digit selected for editing is underlined.

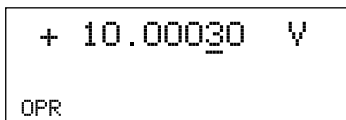

oe72f.eps

Displaying the Output Error

When you edit the output value, the Control Display shows the difference between the reference value (the value you originally entered) and the edit value (the value shown in the Output Display), displaying error difference in parts per million (ppm) or percent (%). For example, if ERR UNI is set to > 100 ppm, the error will be displayed in ppm up to 99 and then the error will change to 0.0100% at 100 ppm. This allows you to edit the output such that the UUT displays the expected value and thus give an indication of the UUT accuracy

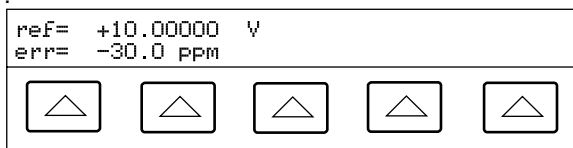

oe73f.eps

For example, the edited difference of 0.00030 V for an output of 10.00000 V represents $0.00030/10.00000=0.000030$, or 30 ppm.

Multiplying and Dividing

Press **MULT** to multiply the output by 10. Press **DIV** to divide the output by 10. If multiplied output exceeds 33 V, the Calibrator is placed in STBY (Standby).

Setting Voltage and Current Limits

Output limits help prevent accidental damage to UUTs from overcurrent or overvoltage. Selections are saved in nonvolatile memory. Voltage limits are expressed in rms.

To set voltage and current limits.

1. Press **RESET** to clear the Calibrator output.
2. Press **SETUP**. Press INSTMT SETUP to open setup submenus.
3. Press OUTPUT SETUP to open output setup submenus.
4. Press SET LIMITS to open set limits menu.

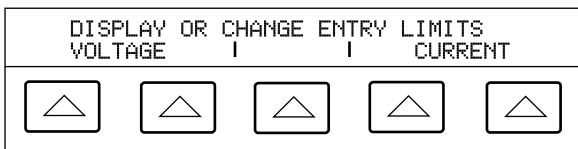



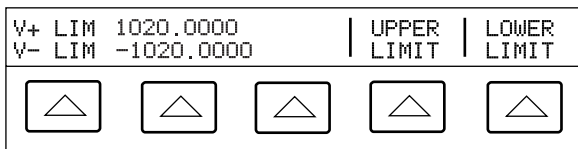

oe74f.eps

5. To limit voltage (applies to both dc and ac voltages), press the softkey under VOLTAGE.



oe75f.eps

- a. Press UPPER LIMIT or LOWER LIMIT, as desired, and enter new limit.
 - b. Press then one or more times to return to previous menus.
6. To limit current (applies to both dc and ac currents), press the softkey under CURRENT.

I+ LIM	20.5000	UPPER	LOWER	
I- LIM	-20.5000	LIMIT	LIMIT	
				

oe76f.eps

- a. Press “Upper Limit” or “Lower Limit”, as desired, and enter the new limit.
- b. Press then one or more times to return to previous menus.

Synchronizing the Calibrator using 10 MHz IN/OUT

You can synchronize one or more 5520A Calibrators using the 10 MHz IN and OUT input/output on the rear panel. Example applications of this capability are connecting two or more Calibrators in parallel in the current output function to sum their outputs, or using three Calibrators to calibrate a three-phase power meter.

Another use for the 10 MHz IN reference input is to improve the frequency performance of the 5520A by injecting a reference 10 MHz clock signal. That application is described next.

Using an External 10 MHz Clock

The Calibrator uses an internal 10 MHz clock signal as a reference for all ac functions. Although this internal clock is very accurate and stable, you may have a lab standard that you want to have govern the frequency performance of the Calibrator. To apply an external clock to the Calibrator, you have two choices. You can make external reference the power-up and reset default condition, or you can select external reference as a volatile setting for the operating session only.

To make external reference the power-up and reset default setting, proceed as follows:

1. Connect a 10 MHz squarewave signal of 5 V p-p (maximum) to the rear panel 10 MHz IN BNC connector.
2. Press the **SETUP** key.
3. Press the following sequence of softkeys: INSTMT SETUP, OUTPUT SETUP, ϕ & REF SETUP.
4. Press the REF CLK softkey to select “ext.”
5. Press the **PREV MENU** key.
6. To use an external 10 MHz reference on a temporary (volatile) basis, proceed as follows:
7. Connect a 10 MHz squarewave signal of 5 V p-p (maximum) to the rear panel 10 MHz IN BNC connector.
8. Set the Calibrator output to an ac voltage or current function.

9. Press the following sequence of softkeys: INSTMT SETUP, OUTPUT SETUP, ϕ & REF SETUP.
10. Press the REF CLK softkey to select “ext.”
11. Press the  key.

Sourcing Current with Parallel-Connected 5520As

You can connect two or more 5520As to source current in parallel. This technique allows you to source current greater than $\pm 20\text{A}$. You must synchronize the Calibrators in order to have their output currents in phase. Proceed as follows to accomplish this:

1. **With both 5520As in standby mode**, make the connections as shown in the next figure.
2. On 5520A #2, select external reference, set the output to the desired ac current level, and activate output mode.
3. On 5520A #1, set the output to the desired ac current level, and activate output mode. This sends a sync pulse to 5520A #2. Now both 5520As are sourcing current in phase, in parallel.

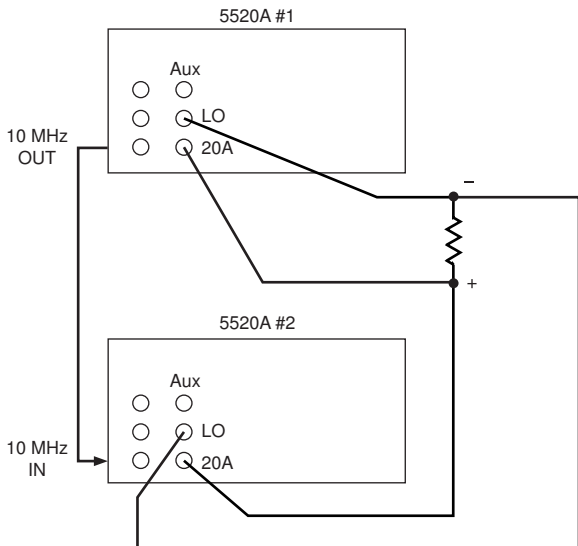

oe78f.eps

Performance Verification

Chapter 7 of the *5520A Operators Manual* describes tests that verify the performance of the Calibrator. If an out-of-tolerance condition is found, the 5520A can be re-calibrated from the front panel or through the remote interface. From the front panel, you are prompted through the complete calibration procedure. Complete details for calibrating the 5520A are provided in the *5520A Service Manual*.

Refer to “Performance Verification” in Chapter 7 of the *5520A Operators Manual* for a list of required equipment. If a specific instrument is not available, another instrument that assures a 4:1 Test Uncertainty Ratio may be substituted.

Internal Fuses

In addition to the line fuse that can be replaced by the operator (see “Replacing the Fuse”), there are fuses mounted on printed circuit assemblies inside the Calibrator. These fuses cannot be replaced by the operator. For fuse locations and descriptions, refer to “Internal Fuse Replacement” in Chapter 7 of the *5520A Operators Manual*. For instructions on replacing an internal fuse, refer to the *5520A Service Manual*.