

P/N: T198065

Copyright

© 2016, FLIR Systems, Inc.

All rights reserved worldwide. Names and marks appearing herein are either registered trademarks or trademarks of FLIR Systems and/or its subsidiaries. All other trademarks, trade names or company names referenced herein are used for identification only and are the property of their respective owners.

Document identity

Publ. No.: T198065
 Release:
 Commit: 29700
 Language: en-US
 Modified: 2015-10-16
 Formatted: 2016-05-31

Website

<http://www.flir.com>

Customer support

<http://support.flir.com>

Disclaimer

Specifications subject to change without further notice. Camera models and accessories subject to regional market considerations. License procedures may apply. Products described herein may be subject to US Export Regulations. Please refer to exportquestions@flir.com with any questions.



General description	
This wide angle lens has a field of view approximately three times that of the standard 25° lens. This lens is suitable for extremely cramped situations where the operator can not step farther back from the object.	
Imaging and optical data	
Field of view (FOV)	80° × 64.4° (92.8° diagonal)
Minimum focus distance	65 mm (2.6 in.)
Focal length	6.5 mm (0.26 in.)
Spatial resolution (IFOV)	2.62 mrad
Lens identification	Automatic
F-number	1.0
Number of lenses	5 (5 asph)
MTF @ 70% of FOV	Normal requirements (52%)
Distortion	5%
Physical data	
Weight	0.428 kg (0.944 lb.)
Size (L × D)	126 × 67 mm (4.96 × 2.64 in.)
Front lens diameter	25 mm 0.98 in.)
Shipping information	
Packaging, type	Cardboard box
List of contents	<ul style="list-style-type: none"> • Lens • Lens case • Front lens cap • Rear lens cap
Packaging, weight	0.680 kg (1.5 lb.)
Packaging, size	174 × 133 × 133 mm (6.9 × 5.2 × 5.2 in.)
EAN-13	7332558004418
UPC-12	845188004415
Country of origin	Sweden

Compatible with the following products

- 55903-1015; FLIR T600 15° (incl. Wi-Fi and Ext. cal.)
- 55903-0922; FLIR T600 15° (incl. Wi-Fi)
- 55903-1016; FLIR T600 25° (incl. Wi-Fi and Ext. cal.)
- 55903-1022; FLIR T600 25° (incl. Wi-Fi)

P/N: T198065

© 2016, FLIR Systems, Inc.

#T198065; r./29700; en-US

- 55903-1007; FLIR T600 25° and 15° w/case
- 55903-1008; FLIR T600 25° and 45° w/case
- 55903-1017; FLIR T600 45° (incl. Wi-Fi and Ext. cal.)
- 55903-1522; FLIR T600 45° (incl. Wi-Fi)
- 55903-2823; FLIR T600bx 25° (incl. Wi-Fi and Ext. cal.)
- 55903-2822; FLIR T600bx 25° (incl. Wi-Fi)
- 55903-2923; FLIR T600bx 45° (incl. Wi-Fi and Ext. cal.)
- 55903-2922; FLIR T600bx 45° (incl. Wi-Fi)
- 55903-8022; FLIR T610 15° (incl. Wi-Fi)
- 55903-3922; FLIR T610 25° (incl. Wi-Fi)
- 55903-4022; FLIR T610 45° (incl. Wi-Fi)
- 55903-5023; FLIR T620 15° (incl. Wi-Fi and Ext. cal.)
- 55903-5022; FLIR T620 15° (incl. Wi-Fi)
- 55903-5125; FLIR T620 25° (incl. Wi-Fi and Ext. cal.)
- 55903-5122; FLIR T620 25° (incl. Wi-Fi)
- 55903-5123; FLIR T620 25° and 15° (incl. Wi-Fi)
- 55903-5124; FLIR T620 25° and 45° (incl. Wi-Fi)
- 55903-5223; FLIR T620 45° (incl. Wi-Fi and Ext. cal.)
- 55903-5222; FLIR T620 45° (incl. Wi-Fi)
- 55903-5623; FLIR T620bx 15° (incl. Wi-Fi and Ext. cal.)
- 55903-5622; FLIR T620bx 15° (incl. Wi-Fi)
- 55903-5723; FLIR T620bx 25° (incl. Wi-Fi and Ext. cal.)
- 55903-5722; FLIR T620bx 25° (incl. Wi-Fi)
- 55903-5823; FLIR T620bx 45° (incl. Wi-Fi and Ext. cal.)
- 55903-5822; FLIR T620bx 45° (incl. Wi-Fi)
- 55904-6222; FLIR T630 15° (incl. Wi-Fi)
- 55904-6322; FLIR T630 25° (incl. Wi-Fi)
- 55904-6422; FLIR T630 45° (incl. Wi-Fi)
- 55904-8023; FLIR T630sc 15° (incl. Wi-Fi)
- 55904-8123; FLIR T630sc 25° (incl. Wi-Fi)
- 55904-8124; FLIR T630sc 25° and 45° w/case
- 55904-8223; FLIR T630sc 45° (incl. Wi-Fi)
- 55904-6823; FLIR T640 15° (incl. Wi-Fi and Ext. cal.)
- 55904-6822; FLIR T640 15° (incl. Wi-Fi)
- 55904-6925; FLIR T640 25° (incl. Wi-Fi and Ext. cal.)
- 55904-6922; FLIR T640 25° (incl. Wi-Fi)
- 55904-6923; FLIR T640 25° and 15° (incl. Wi-Fi)
- 55904-6924; FLIR T640 25° and 45° (incl. Wi-Fi)
- 55904-7023; FLIR T640 45° (incl. Wi-Fi and Ext. cal.)
- 55904-7022; FLIR T640 45° (incl. Wi-Fi)
- 55904-7423; FLIR T640bx 15° (incl. Wi-Fi and Ext. cal.)
- 55904-7422; FLIR T640bx 15° (incl. Wi-Fi)
- 55904-7523; FLIR T640bx 25° (incl. Wi-Fi and Ext. cal.)
- 55904-7522; FLIR T640bx 25° (incl. Wi-Fi)
- 55904-7623; FLIR T640bx 45° (incl. Wi-Fi and Ext. cal.)
- 55904-7622; FLIR T640bx 45° (incl. Wi-Fi)
- 55904-7723; FLIR T650sc 15° (incl. Wi-Fi)
- 55904-7823; FLIR T650sc 25° (incl. Wi-Fi)
- 55904-7824; FLIR T650sc 25° and 15° w/case
- 55904-7825; FLIR T650sc 25° and 45° w/case
- 55904-7923; FLIR T650sc 45° (incl. Wi-Fi)
- 55904-8423; FLIR T660 15° (incl. Wi-Fi and Ext. cal.)
- 55904-8422; FLIR T660 15° (incl. Wi-Fi)
- 55904-8523; FLIR T660 25° (incl. Wi-Fi and Ext. cal.)
- 55904-8522; FLIR T660 25° (incl. Wi-Fi)
- 55904-8524; FLIR T660 25° and 15° w/case
- 55904-8525; FLIR T660 25° and 45° w/case
- 55904-8623; FLIR T660 45° (incl. Wi-Fi and Ext. cal.)
- 55904-8622; FLIR T660 45° (incl. Wi-Fi)



IR lens, f=6.5 mm (80°) with case

P/N: T198065

© 2016, FLIR Systems, Inc.

#T198065; r./29700; en-US

- 55001-0101; FLIR A615 15°
- 55001-0102; FLIR A615 25°
- 55001-0103; FLIR A615 45°
- 55001-0104; FLIR A615 7°
- 55001-0105; FLIR A615 80°
- 55001-0301; FLIR A655sc 15°
- 55001-0302; FLIR A655sc 25°
- 55001-0303; FLIR A655sc 45°
- 55001-0304; FLIR A655sc 7°
- 55001-0305; FLIR A655sc 80°

Camera with Lens IR f=6,5 mm (80°)

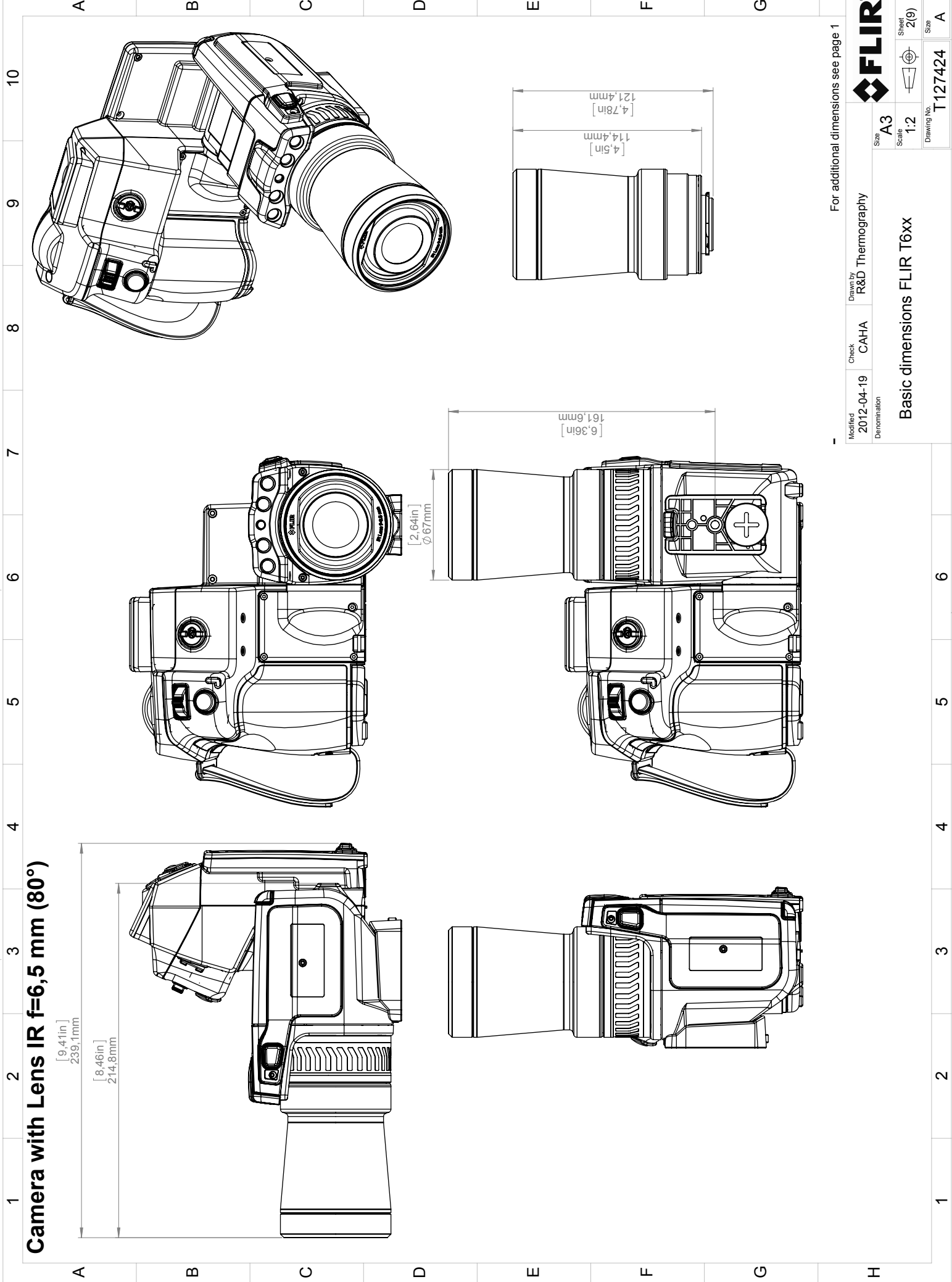
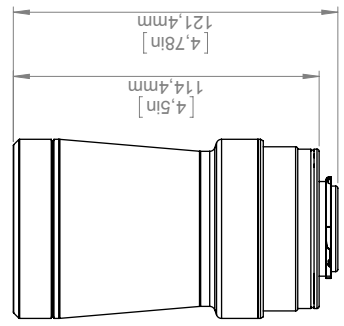
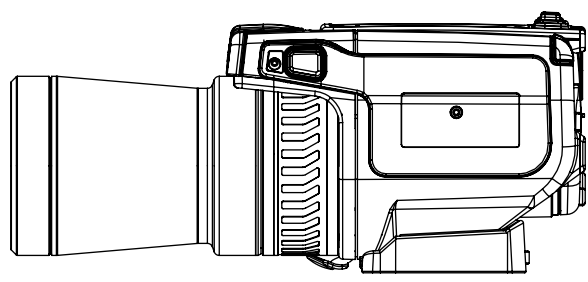
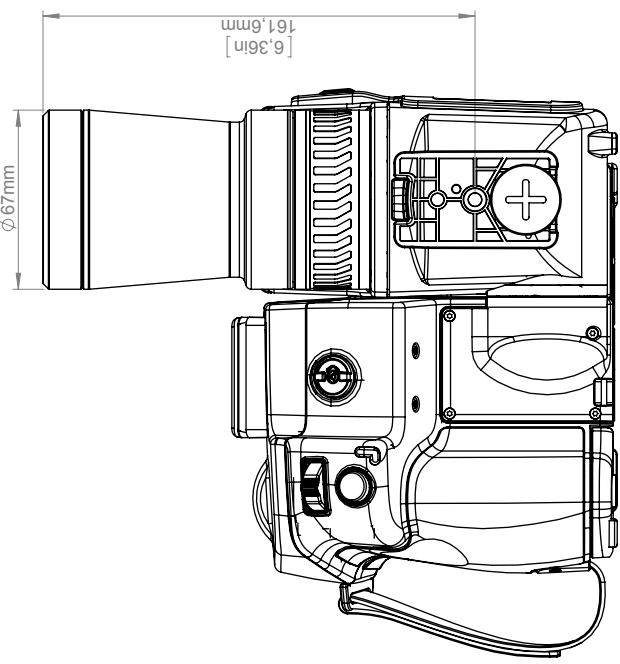
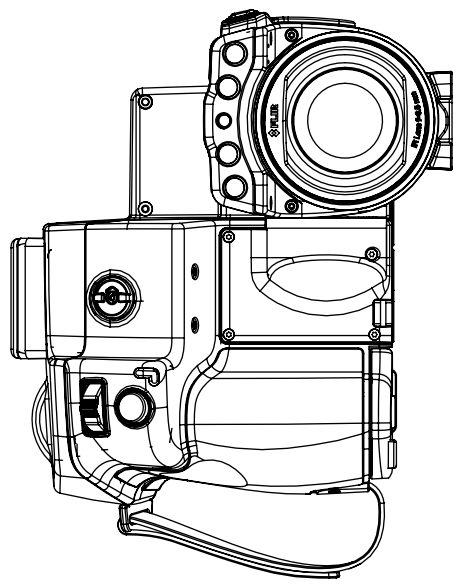
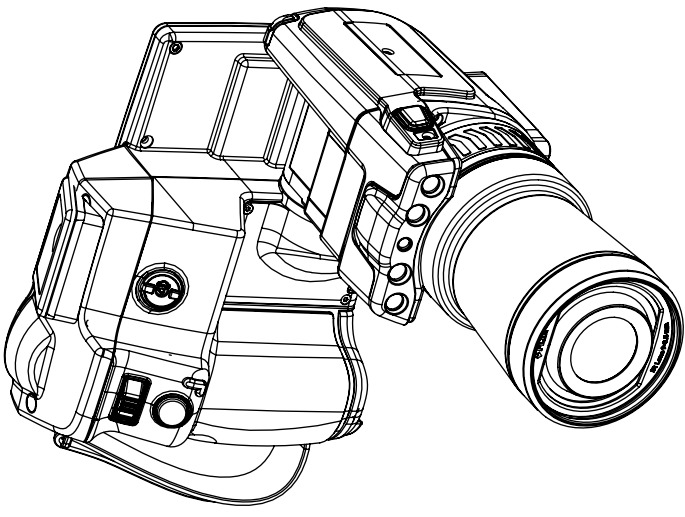
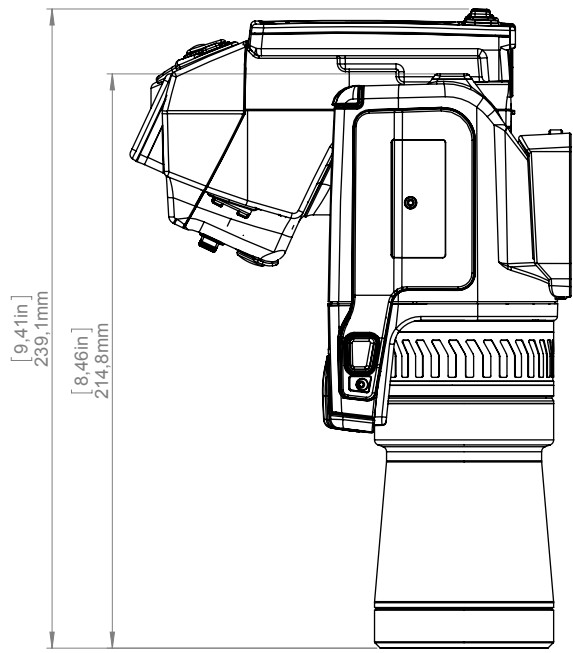

© 2012, FLIR Systems, Inc. All rights reserved worldwide. No part of this drawing may be reproduced, stored in a retrieval system, or transmitted in any form, or by any means, electronic, mechanical, photocopying, recording, or otherwise, without written permission from FLIR Systems, Inc. Specifications subject to change without further notice. Dimensional data is based on nominal values. Products may be subject to regional market considerations. License procedures may apply. Product may be subject to US Export Regulations. Please refer to exportquestions@flir.com with any questions. Diversion contrary to US law is prohibited.

For additional dimensions see page 1

Modified 2012-04-19	Check CAHA	Drawn by R&D Thermography	FLIR®
Denomination Basic dimensions FLIR T6xx			Size A3
			Scale 1:2
			Sheet 2(9)
			Drawing No. T127424
			Size A

Camera with Lens IR f=6,5 mm (80°)

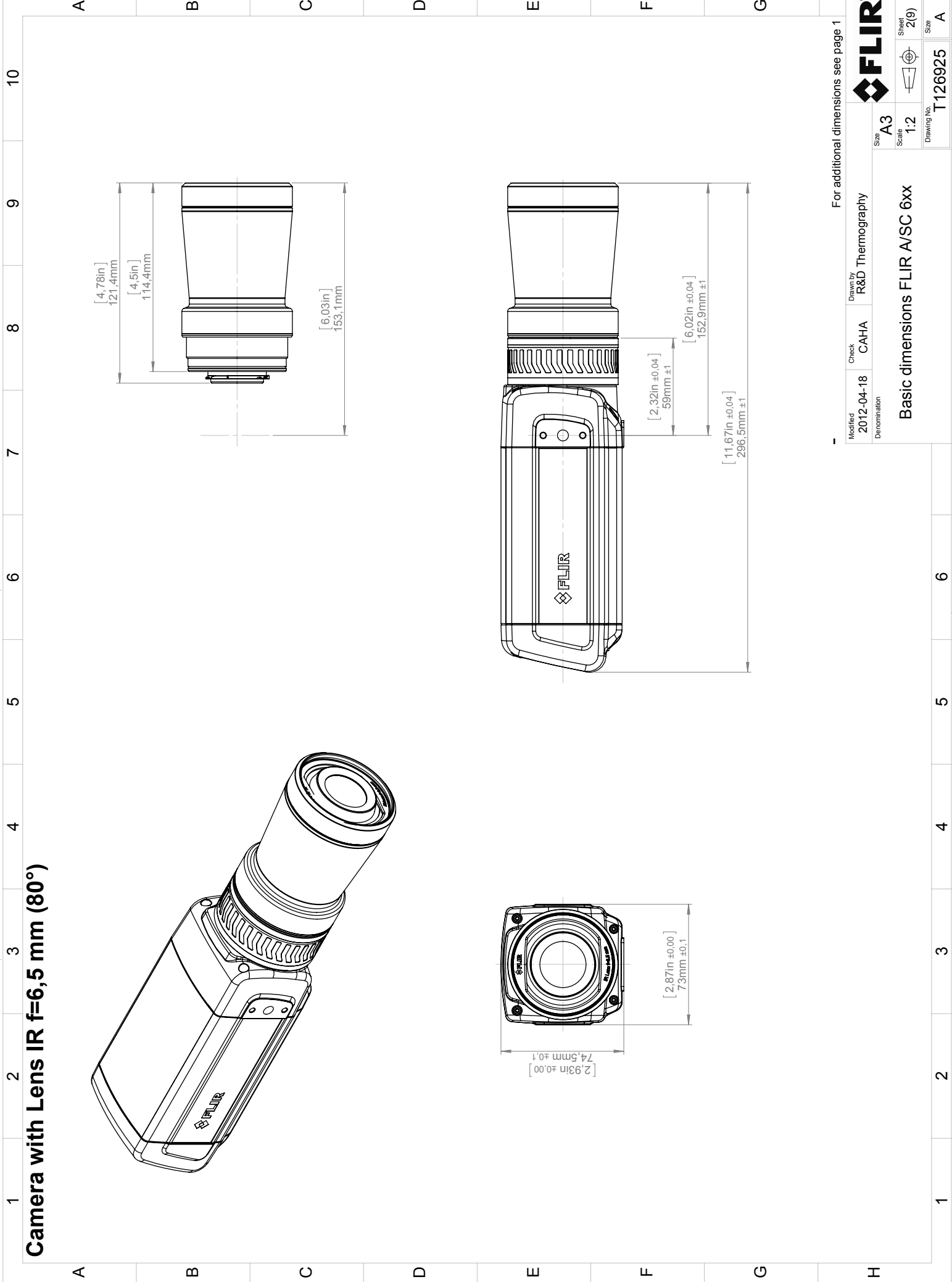
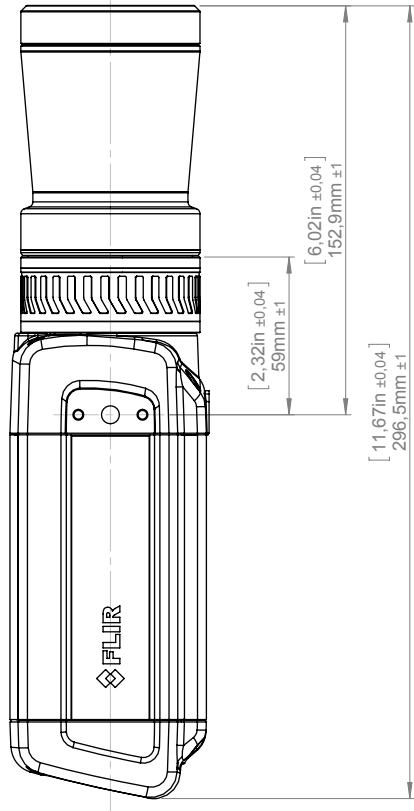
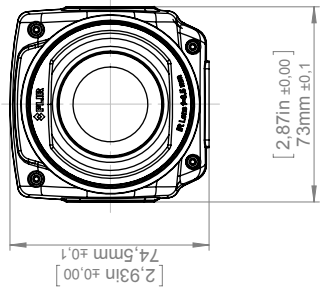
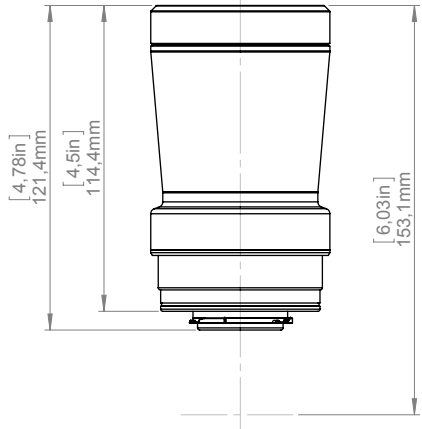
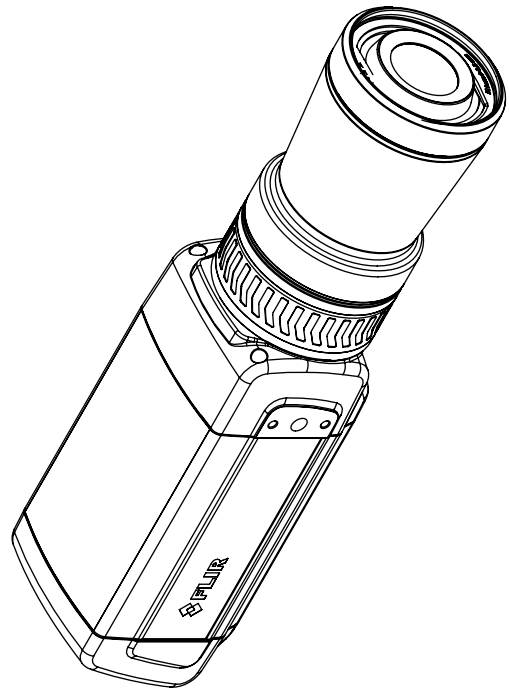

For additional dimensions see page 1

FLIR

Modified 2012-04-18	Check CAHA	Drawn by R&D Thermography	Size A3
Denomination Basic dimensions FLIR A/SC 6xx			Scale 1:2
			Sheet 2(9)
			Drawing No. T126925
			Size A

© 2012, FLIR Systems, Inc. All rights reserved worldwide. No part of this drawing may be reproduced, stored in a retrieval system, or transmitted in any form, or by any means, electronic, mechanical, photocopying, recording, or otherwise, without written permission from FLIR Systems, Inc. Specifications subject to change without further notice. Dimensional data is based on nominal values. Products may be subject to regional market considerations. License procedures may apply. Product may be subject to US Export Regulations. Please refer to exportquestions@flir.com with any questions. Diversion contrary to US law is prohibited.