

ELGAR

**PROGRAMMABLE
DC SYSTEM**

MODEL AT8000A
OPERATION MANUAL

ELGAR ELECTRONICS CORPORATION

9250 Brown Deer Road
San Diego, CA 92121-2294
1-800-733-9427
Tel: (858) 450-0085
Fax: (858) 450-0267
Email: sales@elgar.com
www.elgar.com

©1999 by Elgar Electronics Corporation

This document contains information proprietary to Elgar Electronics Corporation. The information contained herein is not to be duplicated or transferred in any manner without prior written permission from Elgar Electronics Corporation.

December 13, 1999

Document No. M691219-01-01 Rev D

ELGAR ONE-YEAR WARRANTY

Elgar Electronics Corporation (hereinafter referred to as Elgar) warrants its products to be free from defects in material and workmanship. This warranty is effective for one year from the date of shipment of the product to the original purchaser. Liability of Elgar under this warranty shall exist provided that:

- the Buyer exposes the product to normal use and service and provides normal maintenance on the product;
- Elgar is promptly notified of defects by the Buyer and that notification occurs within the warranty period;
- the Buyer receives a Return Material Authorization (RMA) number from Elgar's Repair Department prior to the return of the product to Elgar for repair, phone 800-73-ELGAR (800-733-5427), ext. 2295;
- the Buyer returns the defective product in the original, or equivalent, shipping container;
- if, upon examination of such product by Elgar it is disclosed that, in fact, a defect in materials and/or workmanship does exist, that the defect in the product was not caused by improper conditions, misuse, or negligence; and,
- that Elgar QA seal and nameplates have not been altered or removed and the equipment has not been repaired or modified by anyone other than Elgar authorized personnel.

This warranty is exclusive and in lieu of all other warranties, expressed or implied, including, but not limited to, implied warranties of merchantability and fitness of the product to a particular purpose. Elgar, its agents, or representatives shall in no circumstance be liable for any direct, indirect, special, penal, or consequential loss or damage of any nature resulting from the malfunction of the product. Remedies under this warranty are expressly limited to repair or replacement of the product.

CONDITIONS OF WARRANTY

- To return a defective product, contact an Elgar representative or the Elgar factory for an RMA number. Unauthorized returns will not be accepted and will be returned at the shipper's expense.
- For Elgar products found to be defective within thirty days of receipt by the original purchaser, Elgar will absorb all ground freight charges for the repair. Products found defective within the warranty period, but beyond the initial thirty-day period, should be returned prepaid to Elgar for repair. Elgar will repair the unit and return it by ground freight pre-paid.
- Normal warranty service is performed at Elgar during the weekday hours of 7:30 am to 4:30 pm Pacific time. Warranty repair work requested to be accomplished outside of normal working hours will be subject to Elgar non-warranty service rates.
- Warranty field service is available on an emergency basis. Travel expenses (travel time, per diem expense, and related air fare) are the responsibility of the Buyer. A Buyer purchase order is required by Elgar prior to scheduling.
- A returned product found, upon inspection by Elgar, to be in specification is subject to an inspection fee and applicable freight charges.
- Equipment purchased in the United States carries only a United States warranty for which repair must be accomplished at the Elgar factory.

ELGAR

Committed to Quality...Striving for Excellence

SAFETY NOTICE

BEFORE APPLYING POWER to the System, verify that the Model AT8000A Programmable DC System is properly configured for the user's particular application.

WARNING

HAZARDOUS VOLTAGES IN EXCESS OF 230 VRMS, 400V PEAK MAY BE PRESENT WHEN COVERS ARE REMOVED. QUALIFIED PERSONNEL MUST USE EXTREME CAUTION WHEN SERVICING THIS EQUIPMENT. CIRCUIT BOARDS, TEST POINTS AND OUTPUT VOLTAGES MAY ALSO BE FLOATING ABOVE (BELOW) CHASSIS GROUND.

Installation and servicing must be performed by QUALIFIED PERSONNEL who are aware of properly dealing with attendant hazards. This includes such simple tasks as fuse verification and channel reconfiguration.

Ensure that the AC power line ground is properly connected to the Model AT8000A input connector. Similarly, other power ground lines including those to application and maintenance equipment **MUST** be properly grounded for both personnel and equipment safety.

Always ensure that facility AC input power is de-energized prior to connecting or disconnecting the power cable. Similarly, the Model AT8000A circuit breaker must be switched OFF prior to connecting or disconnecting output power.

In normal operation, the operator does not have access to hazardous voltages within the chassis. However, depending on the user's application configuration, **HIGH VOLTAGES HAZARDOUS TO HUMAN SAFETY** may be normally generated on the output terminals. The Customer/User must ensure that the output power (and sense) lines be properly labeled as to the SAFETY hazards and any that inadvertent contact with hazardous voltages is eliminated.

Guard against risks of electrical shock during open cover checks by **NOT TOUCHING** any portion of the electrical circuits. Even when power is OFF, capacitors may retain an electrical charge. Use **SAFETY GLASSES** during open cover checks to avoid personal injury by any sudden component failure.

	<u>Page</u>
Warranty	i
Safety Notice	ii
Table of Contents	iii

SECTION I – GENERAL DESCRIPTION

1.1	INTRODUCTION	1-1
1.2	GENERAL DESCRIPTION	1-1
1.3	OPTIONS	1-4
1.4	OVERALL SYSTEM SPECIFICATIONS	1-4
	1.4.1 Electrical	1-4
	1.4.2 General Specifications	1-7
	1.4.3 Mechanical Specifications	1-7
	1.4.4 Programming Specifications	1-8
	1.4.5 Auxiliary Drive Module Specifications	1-9
	1.4.6 Electronic Load Module Specifications	1-10
1.5	INPUT CONNECTOR DEFINITIONS	1-15
	1.5.1 Terminal Block Version	1-15
	1.5.2 MS Connector Version	1-15

SECTION II – INSTALLATION

2.1	INTRODUCTION	2-1
2.2	UNPACKING	2-1
	2.2.1 Inspecting The Package	2-1
	2.2.2 Pre-Installation Inspection	2-2
2.3	INSTALLATION	2-2
	2.3.1 DC Module/Electronic Load Module Installation	2-2
	2.3.2 Master/Slave Modules	2-3
	2.3.3 Dummy Modules	2-10
	2.3.4 DC Power Module Output Relays	2-10
2.4	CONFIGURATION	2-10
	2.4.1 Basic System	2-11
	2.4.2 Complex System	2-11
	2.4.3 Make Extender Chassis From Master Chassis	2-11
	2.4.4 Emergency Shutdown Input Panic Button	2-12
	2.4.5 Series Operation	2-15
	2.4.6 Parallel Operation With Master/Slave	2-18
	2.4.7 Parallel Operation With Standard Masters	2-18

	<u>Page</u>
2.5 REAR PANEL SWITCHES AND CONNECTIONS	2-22
2.5.1 Load Connections	2-22
2.5.2 AC Input Power	2-25
2.5.3 MS Connector AC Input Line Connectors	2-26
2.5.4 IEEE-488 Interface	2-26
2.5.5 Channel Group Select	2-28
2.5.6 DFI/Shutdown	2-29
2.5.7 External I/O Connector	2-30
2.6 PROCESSOR BOARD JUMPER SETTINGS	2-31
2.6.1 W1 - CIIL/ABLE Language	2-31
2.6.2 W2 - Input to Emergency Shutdown	2-31
2.6.3 W3 - Local Lock Out	2-31
2.6.4 W4 - Troubleshooting Aid	2-31
2.6.5 W5 - Skip Confidence Test #4	2-31
2.6.6 W6 through W11	2-31
2.7 AUXILIARY DRIVE MODULE INSTALLATION AND CONFIGURATION	2-31
2.7.1 Installation	2-32
2.7.2 Configuration	2-32
2.7.3 Required Information From External Supply	2-32
2.7.4 ID PROM - U13	2-33
2.7.5 Voltage DAC Section - R54 and Zero Offset	2-34
2.7.6 Low Voltage Control Output - R43 and R48	2-35
2.7.7 High Voltage Control Output - R18	2-35
2.7.8 Current DAC Section - R53 and R71	2-35
2.7.9 Current Control Section - R56 and R57	2-36
2.7.10 Voltage Sense - R10, R11, and R16	2-36
2.7.11 Current Sense - R27, R66, and R70	2-36
2.8 FUNCTIONAL VERIFICATION	2-37
2.8.1 Test Equipment Requirements	2-37
2.8.2 Logging System Data	2-38
2.8.3 Record Data on the Appendix B Checksheet	2-39
2.8.3.1 AC Input	2-39
2.8.3.2 Remote Programming Language	2-39
2.8.3.3 GPIB Address Select	2-39
2.8.3.4 Group Select	2-39
2.8.3.5 Local Control Keyboard/Display	2-39
2.8.3.6 Test	2-39
2.8.3.7 Output Connections	2-40
2.8.3.8 DC Modules Installed	2-40

SECTION III – OPERATION

3.1	INTRODUCTION	3-1
3.2	POWER ON/OFF SEQUENCE	3-1
3.3	LOCAL/REMOTE PROGRAMMING OVERVIEW	3-2
3.4	LOCAL PROGRAMMING (KEYBOARD/DISPLAY)	3-3
3.4.1	Display (LED Status Indicators)	3-4
3.4.2	Keyboard Functions	3-5
3.4.2.1	GTL (Keyboard Go To Local)	3-7
3.4.2.2	CNF (Confidence Test)	3-8
3.4.2.3	TST (Test)	3-8
3.4.2.4	RTN (Return)	3-9
3.4.2.5	Software Parallel	3-9
3.4.2.6	Group Function	3-10
3.4.2.7	System Reset	3-11
3.4.2.8	Display Firmware Version Number	3-11
3.4.2.9	Display GPIB Address	3-11
3.4.2.10	ENT (Enter)	3-11
3.4.2.11	EXC (Execute)	3-12
3.4.2.12	VOLT (Voltage)	3-13
3.4.2.13	CURR (Constant Current)	3-13
3.4.2.14	CURL (Current Limit)	3-14
3.4.2.15	CLS (Close)	3-14
3.4.2.16	SENS (Sense)	3-15
3.4.2.17	POL (Polarity)	3-15
3.4.3	Local Programming Examples	3-16
3.4.4	Electronic Load Module Programming Using The Front Panel	3-16
3.4.4.1	INCRement and DECrement Keys	3-16
3.4.4.2	Constant Current Mode	3-17
3.4.4.3	Constant Resistance Mode	3-17
3.4.4.4	Constant Voltage Mode – VOLT or CURL	3-18
3.4.4.5	Current Pulse Mode	3-18
3.4.4.6	Voltage Pulse Mode (Transient Generator)	3-18
3.4.4.7	Resistance Pulse Mode (Transient Generator)	3-19
3.4.4.8	Short Circuit Mode	3-19
3.4.4.9	Software Parallel Mode	3-19
3.4.4.10	Measuring The Load Current and Voltage	3-20

	<u>Page</u>
3.4.5 Flashing Error Code	3-20
3.4.5.1 Flashing Current Display	3-20
3.4.5.2 Flashing Channel 01 - 16	3-21
3.4.5.3 Flashing Channel 17	3-21
3.4.5.4 Flashing Channel 18	3-21
3.4.5.5 Flashing Channel 19	3-21
3.4.5.6 Flashing Channel 20	3-21
3.5 REMOTE PROGRAMMING IN ABLE	3-22
3.5.1 Hexadecimal Programming Values	3-22
3.5.2 Restrictions on Hexadecimal Values	3-23
3.5.3 Instrument Commands	3-23
3.5.6.1 CNF (Confidence Test)	3-24
3.5.6.2 RST (Reset Channels)	3-25
3.5.6.3 GRP (Group Channels)	3-25
3.5.6.4 PAR (Parallel Channels)	3-26
3.5.6.5 TST (Test Channels)	3-27
3.5.6.6 RTN (Return Channels)	3-27
3.5.6.7 PWRL	3-28
3.5.6.8 VER (Version of Instrument Firmware)	3-29
3.5.6.9 SCR Command to Fire Crowbar	3-29
3.5.6.10 NOX (No Execute)	3-29
3.5.6.11 GET (Group Exercise Trigger)	3-30
3.5.6.12 CIIL Command	3-30
3.5.7 Channel Parameters	3-30
3.5.7.1 CH (Channel Number)	3-31
3.5.7.2 VOLT (Voltage)	3-31
3.5.7.3 CURL (Current Limit)	3-32
3.5.7.4 CURR (Constant Current)	3-32
3.5.7.5 CLS (Close)	3-32
3.5.7.6 OPN (Open)	3-32
3.5.7.7 SENS I (Sense Internal)	3-33
3.5.7.8 SENS X (Sense External)	3-33
3.5.8 Example Message Strings With ABLE	3-33
3.5.9 Remote ABLE Programming for the Electronic Load Module	3-34
3.5.9.1 Constant Current Mode	3-34
3.5.9.2 Constant Voltage Mode	3-35
3.5.9.3 Constant Resistance Mode	3-35
3.5.9.4 Current Pulse Mode (Transient Generator)	3-36
3.5.9.5 Voltage Pulse Mode (Transient Generator)	3-36
3.5.9.6 Resistance Pulse Mode (Transient Generator)	3-37
3.5.9.7 Short Circuit Mode	3-37

	<u>Page</u>	
3.5.10	Examples of Remote Programming of the Electronic Load Module in ABLE	3-37
3.5.10.1	Setting Up the System	3-38
3.5.10.2	Programming the Constant Current Mode	3-39
3.5.10.3	Programming the Constant Voltage Mode	3-40
3.5.10.4	Programming the Constant Resistance Mode	3-41
3.5.10.5	Programming the Constant Low Current Range Mode	3-41
3.5.10.6	Programming the Current Pulse Mode (Transient Generator)	3-41
3.5.10.7	Programming the Voltage Pulse Mode (Transient Generator)	3-42
3.5.10.8	Programming the Resistance Pulse Mode (Transient Generator)	3-42
3.5.10.9	Programming the Short Circuit Mode	3-42
3.5.11	Service Request Status Bytes	3-43
3.6	REMOTE PROGRAMMING WITH CIIL	3-44
3.6.1	Nouns	3-45
3.6.2	Opcodes	3-46
3.6.3	Instrument Level	3-46
3.6.3.1	CNF (Confidence Test)	3-46
3.6.3.2	IST (Internal Self Test)	3-46
3.6.3.3	STA (Status)	3-46
3.6.3.4	CLS (Close Output Isolation Relay)	3-47
3.6.3.5	OPN (Open Output Isolation Relay)	3-47
3.6.4	Functional Levels	3-47
3.6.4.1	RST (Reset Channel)	3-48
3.6.4.2	FNC (Function)	3-48
3.6.4.3	SET (Set)	3-48
3.6.4.4	SRX (Set Maximum)	3-48
3.6.4.5	SRN (Set Minimum)	3-49
3.6.5	Noun Modifiers	3-49
3.6.5.1	VOLT (Voltage)	3-49
3.6.5.2	CURL (Current Limit)	3-49
3.6.5.3	CURR (Constant Current)	3-49
3.6.5.4	TWOW (Two Wire - Internal Voltage Sense)	3-50
3.6.5.5	FORW (Four Wire - External Voltage Sense)	3-50
3.6.6	Remote Measurement Function	3-50
3.6.7	Software Parallel Function	3-51
3.6.8	Parallel Flexibility	3-51
3.6.9	Parallel Restrictions in CIIL	3-52
3.6.10	Software Group Function	3-52

	Page
3.6.11 Group Flexibility	3-53
3.6.12 GAL (Go Alternate Language)	3-53
3.6.13 Remote Programming Example With CIIL	3-53
3.6.14 Status Messages With CIIL	3-54
3.7 IEEE-488 DEFINITIONS	3-56
3.7.1 CIIL Implementation of the GPIB	3-56
3.7.2 ABLE Implementation of the GPIB	3-57

LIST OF APPENDIXES

A	WIRE GAUGE SELECTION	A-1
B	VERIFICATION CHECKSHEET	B-1

LIST OF FIGURES

2-1	Model AT8000A (Front and Side Views)	2-4
2-2	Model AT8000A (Rear Views)	2-5
2-3	DC Power Module Identification	2-6
2-4	DC Power Module Installation	2-6
2-5	DC Power Module Master/Slave Connections	2-7
2-6	Master/Slave Modules	2-9
2-7	Basic System Configuration	2-13
2-8	Complex System Configuration	2-14
2-9	System Series Operation	2-16
2-10	System Series Operation - Better Regulation	2-17
2-11	System Parallel Operation	2-19
2-12	Interconnect Two Master/Slave Channels	2-23
2-13	Chassis Rear View, Two Master/Slave Channels	2-24
2-14	Load and Sense Connections	2-25
2-15	GPIB Address Switch (Rear Panel View)	2-28
2-16	Channel Group Select Switch (Rear Panel View)	2-29
3-1	Model AT8000A Display	3-6
3-2	Model AT8000A Keyboard Functions	3-6

LIST OF TABLES

1-1	Terminal Block Definitions	1-15
1-2	MS Pin Number Definitions	1-15
1-3	MS Connector Part Numbers	1-16
2-1	GPIB Listen Address Settings	2-27
2-2	External I/O Connector Pinout	2-30
2-3	ADM PROMS and Jumpers	2-34
2-4	Test Equipment Requirements	2-38
3-1	Local Programming Examples	3-16
3-2	Service Request Messages	3-44
3-3	GPIB/Mnemonic Listing	3-56
3-4	CIIL Implemented Subsets on GPIB	3-57
3-5	ABLE Implemented Subsets on GPIB	3-58

SECTION I

GENERAL DESCRIPTION

1.1 INTRODUCTION

The Elgar Model AT8000A Programmable DC Power System provides the following attributes and capabilities:

- 1 to 6 Channels per Drawer.
- Expandable to 16 Channels.
- Voltages to 320V.
- 1200W per Single Drawer Output Power.
- Extensive Display Supports Programming, Status, and Faults.
- Easily Reconfigurable V/I Application Ranges.
- IEEE-488 General Purpose Interface Bus (GPIB) Compatible.
- Optional Front Panel Keyboard.
- Full ATE Qualified - MATE, CIIL.
- Multiple Options - BIT, Polarity Relays, Battery Back-up RAM.

1.2 GENERAL DESCRIPTION

The Model AT8000A is a highly flexible precision DC power source designed to serve the challenges of both benchtop and Automatic Test Equipment (ATE) applications. The Model AT8000A incorporates a highly intelligent built in user interface with a wide range of available plug in DC Power Modules to meet the user's specific DC Power needs. The Model AT8000A simplifies and eliminates the complexities of combining individual DC power sources.

The Model AT8000A basic system is a compact rack mountable master chassis drawer offering convenient front panel control via keyboard and display. Remote programming is via the IEEE-488 GPIB using Elgar's ABLE (Atlas Based Language Extension) or CIIL (Control Interface Intermediate Language), as preferred by the user's application. The Model AT8000A internal processor automatically keeps track of all front panel entries, remote programming, displays, error reporting, BIT (Built In Test), and other processes.

The Model AT8000A master chassis contains six slots which are filled with DC Power Modules as required by the user's application. Each slot containing a master DC Power Module is an independently programmable channel DC power source. Master DC Power Modules are available in eight voltage ranges, from 0-7 VDC to 0-320 VDC. The optional polarity relay enables both plus and minus (\pm) programming without external wiring changes to the user's load. Excellent precision is always maintained via internal and external (programmable) voltage sensing.

For increased current (power), up to five slave DC Power Modules may be electrically jumpered to a nearby master DC Power Module. The slave modules are identical to the output performance of its corresponding master module, but the jumpering allows them to track the master module precisely without requiring a new channel assignment or separate programming. This master/ slave arrangement is completely transparent to the Operator/ Programmer.

Several Expansion drawers may be configured together for additional channels and/or increased power per channel (the processor in the master chassis keeps track of everything). Operation is via the same single keyboard and display. Similarly, remote programming is identical via the same GPIB cable and address. Expansion drawers do not have separate keyboards, display, or GPIB programming; the Model AT8000A simply refers to each DC Power Module master/slave set as a different channel regardless of the number of modules or expansion drawers installed.

The master chassis processor supports up to sixteen independent programmable channels.

A Model AT8000A system consists of one master chassis drawer with one to six channels and may have up to 15 additional expansion chassis drawers containing an overall total of 96 DC Power Modules.

Elgar's Auxiliary Drive Module (ADM) is a digital-to-analog converter (DAC) which adds two versatile functions to AT8000A systems. An ADM can act as:

- Two programmable analog signals to drive external AC or DC power sources or other electronic equipment, and/or, as a
- Programmable connect/disconnect relay driver for controlling an external power relay.

Applications include: burn-in chambers requiring both low power and high power sources; semiconductor aging and characterization; factory ATE systems; incoming inspection ATE; functional verification testers; weapons systems

testers; and general avionics equipment evaluation.

With an ADM, a non-Elgar external bulk supply can take on the same personality as an AT8000A DC Power Module -- extending the AT8000A's normal power per module from 200 Watts. ADMs occupy a single AT8000A slot and are addressed as a single channel from the front panel keyboard or over the IEEE-488 bus. The ADM has separate isolated outputs (1 each for programming voltage and current) plus a programmable relay which can serve as a contact closure to activate an external high-power disconnect/isolation relay, or serve as a status indicator. Optional Built-In-Test (BIT) for readback of voltage and current measurements of the external device is also available.

When both multi-channel low power and bulk high power sources are required, adding ADM cards to the AT8000A creates a one-vendor system/subsystem responsibility, and a solution which can minimize system integration time, expense and trouble.

Elgar's versatile Electronic DC Load Modules can be installed in AT8000A Programmable DC Power Systems to simulate real world characteristics for testing, evaluation, and burn-in of DC power supplies, batteries, capacitors, and other power components. For example:

- System ATE Stations where the key priorities are system density and functional flexibility.
- Incoming inspection where the Load's various modes of operation facilitate performance of a full range of tests to verify that purchased parts meet

specifications.

- Quality control testing where loads can be simulated for in process inspection, margin testing, burn-in and final quality assurance.
- Repair depots where creation of comprehensive systems for verification of all repaired components can simplify calibration and minimize returns.

The DC loads operate in five modes:

- Constant Current
- Constant Voltage
- Constant Resistance
- Short Circuit
- Pulse (Transient Generator)

The constant current, voltage and resistance modes can be continuously switched between two preset levels.

The DC Loads are fully software programmable to allow field reconfiguration from 300W to 1800W per chassis to meet changing test system load requirements. Total system space requirements and costs are minimized by internal programmable disconnect relays which reduce hardware and cabling.

Programmable slew rates automatically duplicate the dynamic behavior of real world load conditions, while analog modulation with external sync accurately duplicates complex load waveforms. Remote sensing capabilities increase flexibility and maximize programming and readback accuracy.

Elgar's Electronic DC loads have a full complement of over-voltage, over-power, over-temperature, reverse polarity, reverse sense, and power isolation protection capabilities.

Modular design facilitates easy installation and replacement, and minimizes rack space and GPIB addresses to cut total system costs. Programmability permits reconfiguration with the AT8000A's integral keyboard or remotely via the IEEE-488 bus.

Elgar's Electronic Load modules come standard with an input disconnect relay.

No Reversed Polarity - Unlike the standard DC Power Modules, the Electronic Load does not have the capability of reversed polarity into the load. That is, the positive polarity of the DC input power can not be connected to the negative input terminal and the negative input power can not be connected to the positive input terminal.

In the event that negative power is fed into the load and if remote sense is used, the load module will detect this and will issue an error condition and it will shut down by programming itself to zero and by opening the input disconnect relay.

Presently, Elgar offers two different 300 watt load modules:

- A 60 Volt/60 Ampere module; and,
- A 120 Volt/30 Ampere module.

This section identifies the Model AT8000A options and specifications. Further descriptions of the Model AT8000A DC Power Modules and multiple configurations are included in

Section II, Installation. Front panel controls, display and remote programming are found in Section III, Operation.

1.3 OPTIONS

The following options are available with the Model AT8000A System (consult the factory for specific part numbers and applications):

- Front Panel Keyboard/Display;
- Built In Test Board (for additional V/I output monitoring);
- Expander Chassis Drawer;
- Master to Expander Chassis Drawer Interface Cable J-Box;
- Master (or Slave) DC Power Module with Polarity Relay;
- Dummy Module (for internal airflow ducting);
- MS connectors (AC Power/Channels) with Mates;
- Shutdown (ABLE version);
- Mating Connectors;
- 47-440 Hz Input AC Power;
- ATE Rack Slides;
- Cabinet; and,
- DFI Contact Closure (CIIL operation only).

1.4 OVERALL SYSTEM SPECIFICATIONS

1.4.1 Electrical

Output Voltage Range

Also, for compliance voltage in Constant Current Mode.

Each DC Power Module has a single output voltage range, as follows:

- 0 to 7 VDC
- 0 to 10 VDC
- 0 to 20 VDC
- 0 to 32 VDC
- 0 to 40 VDC
- 0 to 80 VDC
- 0 to 160 VDC
- 0 to 320 VDC

Output Current Range

Each DC Power Module has a single output current range as follows:

- 0 to 7 VDC Module: 15.0 A maximum from 7 VDC to 0 VDC.
- 0 to 10 VDC Module: 12.0 A maximum from 10 VDC to 0 VDC.
- 0 to 20 VDC Module: 10.0 A maximum from 20 VDC to 15 VDC and derating linearly to 6.0 A maximum at 0 VDC.
- 0 to 32 VDC Module: 6.25 A maximum from 32 VDC to 24 VDC and derating linearly to 3.75 A maximum at 0 VDC.
- 0 to 40 VDC Module: 5.0 A maximum from 40 VDC to 30 VDC and derating linearly to 3.0 A maximum at 0 VDC.
- 0 to 80 VDC Module: 2.5 A maximum from 80 VDC to 60 VDC and derating linearly to 1.5 A maximum at 0 VDC.
- 0 to 160 VDC Module: 1.25 A maximum from 160 VDC to 120 VDC and derating linearly to 0.75 A maximum at 0 VDC.
- 0 to 320 VDC Module: 0.625 A

maximum from 320 VDC to 240 VDC and derating linearly to 0.375 A maximum at 0 VDC.

Full Rated Output Power

- 20, 32, 40, 80, 160, and 320 VDC Modules: 200 Watts.
- 10 VDC Module: 120 Watts.
- 7 VDC Module: 105 Watts.

Configuration

Up to six output channels per 5.25" chassis drawer. An internal programmer controls up to 16 output channels among one master and up to 15 extender chassis drawers. All 16 channels are programmed from the master chassis optional keyboard/display and from a single GPIB address. Up to six DC Power Modules per chassis may be connected in master/slave configuration for up to six times the output current per channel.

Voltage Accuracy

$\pm(0.05\%$ of full range voltage $+0.05\%$ of programmed voltage) at 25°C (77°F).

Current Accuracy

$\pm(1\%$ of full range current $+0.05\%$ of programmed current) at 25°C (77°F).

Load Regulation **(Voltage Mode)**

$\pm 0.01\%$ of full range voltage as measured at sense point for master modules; $\pm 0.05\%$ for master/slave configurations.

4 Wire Compensation - Maximum Load line Drop

Do not allow load line voltage drop to exceed 2.0 volts when using external sense (4 wire output). The maximum compensation of the module is limited by over voltage protection circuits to 2 volts over module rating. Example 7 volt module are limited to 9.0 volts as measured at the AT8000 chassis output terminals.

Please refer to Appendix A for proper wire gauge selection.

Load Regulation **(Constant Current Mode)**

$\pm 0.1\%$ of rated current.

Line Regulation **(Voltage Mode)**

$\pm 0.01\%$ for a $\pm 10\%$ line voltage change.

Line Regulation **(Constant Current Mode)**

$\pm 0.05\%$ for a $\pm 10\%$ line voltage change.

Maximum Ripple and Noise **(Voltage Mode)**

RMS Master Module: 1.5 mV RMS or 0.01% of rated output voltage, whichever is greater, from 20 Hz to 100 kHz.

RMS Master/Slave Configuration: 5.0 mV RMS or 0.01% of rated output voltage, whichever is greater, from 20 Hz to 100 kHz.

Peak-to-Peak Master Module: 15 mV peak-to-peak or 0.05% of rated output voltage, whichever is greater, from 20 Hz to 100 kHz.

Peak-to-Peak Master/Slave Configuration: 15 mV peak-to-peak or 0.1% of rated output voltage, whichever is greater, from 20 Hz to 100 kHz.

Maximum Ripple and Noise (Constant Current Mode)

0.1% of maximum rated current from 20 Hz to 100 kHz; 2% peak to peak of maximum rated current from 20 Hz to 20 MHz.

Readback Measurement Accuracy (TST Function)

0.5% of full scale above 1% of full scale for voltage.

1% of full scale above 1% of full scale for current.

Stability (After Warmup)

±0.01% of rated output for 24 hours at constant temperature, line voltage and load conditions.

Temperature Coefficient

±0.01% per °C of rated output voltage in Voltage mode.

±0.025% per °C of rated output current in Constant Current mode.

Response to Step Load Current

Recovers to within ±0.1% of final value in 300 μsec with a 10% step in load current.

Channel to Channel Interaction

Does not exceed specified performance limits of a single module.

Nominal Input Line Voltage

115 VAC or 230 VAC as selected by rear panel switch.

Input Voltage Range

±10% of nominal value.

Input Frequency Range

47 Hz to 63 Hz

Overvoltage Protection

Auto-tracking with automatic shutdown at 110% of programmed output voltage for programmed voltages from 10% to 100% of range. In Constant Current mode, OVP tracks to 110% of programmed compliance voltage.

Overcurrent Protection

Auto-tracking with automatic shutdown at 110% of programmed output current for programmed output currents from 10% to 100% of range.

Input Circuit Breaker

Front panel input circuit breaker is provided for protection and as the ON/OFF power switch.

Fuses

Each DC Power Module is protected by two fuses located within the module.

Fault Detection

Continuously monitors overvoltage, overcurrent, module malfunction and over-temperature conditions. Includes immediate shutdown and reporting. Built In Test includes Confidence Test. Optional Test Board expands test/monitoring.

1.4.2 General Specifications**Operating Temperature Range
(Up to 2000 Feet)**

0°C to 50°C (32°F to 122°F).

**Operating Temperature Range
(Up to 6000 Feet)**

0°C to 35°C (32°F to 95°F).

Storage Temperature Range

-40°C to 75°C (40°F to 167°F).

Storage Altitude

0 to 50,000 feet.

MTBF

10,000 hours with six DC Power Modules operating at rated power output and ambient air inlet temperature of 25°C.

Warmup

30 minutes maximum in a 25°C environment.

Life Expectancy

5 years minimum.

Humidity

0 to 95% non-condensing.

Shock Vibration

MIL-STD-810A and B as applicable to shipment of electrical test equipment.

Efficiency

50% to 60% at full rated output power at nominal AC input voltage, depending upon module voltage.

**Insulation Resistance and Dielectric
Withstanding Voltage**

10 MΩ at 500 VDC at 25°C and <50% relative humidity.

1.4.3 Mechanical Specifications**Size**

19" (483mm) wide by 5 1/4" (133mm) high by 21" (533mm) deep for mounting in a standard RETMA rack.

Net Weight

Approximately 80 pounds (36kg) with six power modules.

Finish

Light gray, color number 26408, per FED STD 595 with black silkscreen, color 27038.

Handles

Front panel mounted lifting handles.

Material

Steel chassis with aluminum front panel.

Cooling

Forced air with three internal cooling fans.

Input Power Connection

Three wire plug type NEMA 5-20P (115 VAC, 20 A) with six foot power cord hardwired to chassis.

Optional MS type connector, P/N MS3102A-16-10P mounted on chassis. Mating connector MS3106-16-10S, strain relief MS3057-8A-1. Mating connector provided with instrument. Customer assembles own AC Power input cable using own cable.

Output Power Connection

Separate four wire output terminal block per DC Power Module.

Optional MS type chassis and mating connector per DC Power Module (refer to Table 1-3). Strain relief P/N MS3057-8A-1. One set of mating connectors (six channels plus one AC Power Input) are provided with the instrument.

Remote Programming Connector

Standard IEEE-488 GPIB female connector.

Remote Chassis Connector

Parallel connection via 37 pin sub-miniature D type 3 connector. Extender chassis interconnect cable Elgar P/N 5970138-01

DFI Shutdown Connector

Five pin Amphenol connector (P/N 126-218) mounted on master chassis rear. Mating connector is Amphenol P/N 126-217. Shutdown is an option in ABLE version. DFI/Shutdown combination is available on optional CIIL version only.

1.4.4 Programming Specifications**Interface**

IEEE 488-1978 GPIB (General Purpose Interface Bus) interface standard including subsets SH1, AH1, T6, L4, SR1, RL1, and DC1. CIIL version replaces SR1 with SR0.

GPIB Address

Set by rear panel DIP switch.

Number of Channels

Up to 16 at a single GPIB address.

Modes of Operation

Voltage Mode: Programmable output voltage with programmable upper current limit.

Constant Current Mode: Programmable output current with programmable compliance voltage limit.

Voltage Programming Range

7 and 10 VDC Modules: 0 to full scale current.

20, 40, 80, 160, and 320 VDC Modules: 0 to full scale current above 75% of full scale voltage in the Voltage Mode.

Refer to the Output Current Range for the current derating specifications.

20, 32, 40, 80, 160, and 320 VDC Modules: 0 to 60% of full scale current in the Constant Current Mode.

Maximum Resolution

10 mV and 10 mA or 1 part in 3972, whichever is less (resolution) for modules of <100V. 10 mV and 10 mA for modules of 100 volts or higher.

The voltage resolution of 7 VDC modules is 1.76 mV.

Module Identification

DC Power Module voltage range, current characteristics and options are via an internal PROM.

Language Version

ELGAR's ABLE and CIIL (Jumper Selectable).

1.4.5 Auxiliary Drive Module Specifications**Analog Output**

Voltage: Adjustable to 10 VDC at 5 mA for 0 to full scale control.

Current: Adjustable to 10 VDC at 5mA for 0 to full scale control.

High Voltage: 0V to 100V with 20 mA source and 10 mA sink for voltage and current.

Isolation: Both the voltage and current control signals are isolated from the other outputs.

Voltage Accuracy

±0.5% of full range voltage and programmed voltage.

Current Accuracy

±0.1% of full range current; ±0.5% of programmed current.

Voltage Resolution

10 mV for power supplies of <40V full scale.

1 bit in 4000 for power supplies from 40V to 100V.

100 mV for power supplies from 100V to 400V.

1 bit in 4000 for power supplies from 400V to 1000v.

Current Resolution

10 mA for power supplies of <40A full scale.

1 bit in 4000 for power supplies from 40A to 1000A.

Temperature Coefficient

100 ppm per °C.

Load Voltage and Current Measurement Accuracy

1% of full scale above 1% of full scale for voltage; 2% of full scale above 1% of full scale for current.

Load Isolation Relay

Programmable relay can disconnect load from power supply.

Over-Voltage Protection

Auto-tracking with automatic shutdown at 110% of programmed voltage from 10% to 100% of range.

Emergency Shutdown

Either a manual or computer controlled quiescent state/reset input is provided to disconnect the load and program the power supply to zero.

Over-Current Protection

Auto-tracking with automatic shutdown at 110% of programmed current from 10% to 100% of range.

Built In Confidence Test

A Self Test is performed on power up or upon request. The self test verifies operation and accuracy of the analog outputs with the optional test board.

Local Control

Via the front panel display and keyboard.

Languages

CIIL from MATE specification; ABLE.

1.4.6 Electronic Load Module Specifications

The following are the specifications of Elgar's Electronic Load modules. All specifications apply over a voltage range of >1V to full scale voltage unless otherwise specified, and over the temperature range of up to 40°C at 300 Watts continuous and up to 50°C at 200 Watts continuous.

Modes of Operation

- Constant Current Mode
- Constant Low Current Range Mode
- Constant Voltage Mode
- Constant Resistance Mode
- Current Pulse Mode (Transient Generator)
- Voltage Pulse Mode (Transient Generator)
- Resistance Pulse Mode (Transient Generator)

• Short Circuit Mode

Constant Current Mode

60 Volt/60 Amp 120 Volt/30 Amp

Range:
0 to 60 Amps 0 to 30 Amps

Accuracy:
0.1% ±75 mA 0.1% ±75 mA

Resolution:
20 mA 10 mA

Temperature Coefficient:
100 ppm/°C 100 ppm/°C
±4mA/°C ±4mA/°C

Regulation:
10 mA 10 mA

Constant Low Current Range Mode

60 Volt/60Amp 120 Volt/30 Amp

Range:
0 to 6 Amps 0 to 3 Amps

Accuracy:
0.1% ±30 ma 0.1% ±30 ma

Resolution:
2 mA 1 mA

Constant Voltage Mode

60 Volt/60 Amp 120 Volt/30 Amp

Range:
0V to 60V 0V to 120V

Accuracy:
0.1% ±50 mV 0.1% ±50 mV

Resolution:
20 mV 100 mV

Temperature Coefficient:
100 ppm/°C 100 ppm/°C
±5mv/°C ±5mv/°C

Regulation:
±10 mV 20 mV

Constant Resistance Mode

60 Volt/60 Amp 120 Volt/30 Amp

Range:
0.01 to 99.99 Ω 0.1 to 999.9 Ω

Accuracy:
6A: 0.5% + up to 30mA (shunted) 3A: 0.5% + up to 20mA (shunted)

60A: 0.5% + up to 75mA (shunted) 30A: 0.5% + up to 70mA (shunted)

Resolution (Up to 10 Ω):
0.01 Ω 0.1 Ω

Resolution (10 to 99.99 Ω):
0.05 Ω 0.1 Ω

Resolution (100 to 999.9 Ω):
N/A 0.5 Ω

Temperature Coefficient:
100 ppm/°C 100 ppm/°C
±5mv/°C ±5mv/°C

Regulation (Up to 2 Ω):
±10 mV ±10 mV

Regulation (2 to 99.99 Ω):
±15 mA ±15 mA

Regulation (100 to 999.9 Ω):
N/A ±15 mA

Current Pulse Mode
(Transient Generator)
60 Volt/60 Amp 120 Volt/30 Amp

Range (Remote only):
 1 Hz to 10 kHz 1 Hz to 10 kHz

Local Default:
 200 Hz 200 Hz

Duty Cycle Range (Remote Only):
 3% to 97% 3% to 97%

Local Default:
 50% 50%

Current Range:
 0 to 60 Amp 0 to 30 Amp

Resolution:
 20 mA 10 mA

Accuracy:
 0.1% ±75 mA 0.1% ±75 mA

Programmable Slew Rate:
 1A/μs, 0.5A/μs 2A/μs, 1A/μs
 0.1A/μs, 0.1A/μs,
 0.01A/μs 0.01A/μs

Slew Rate Accuracy:
 ±25% ±25%

Voltage Pulse Mode
(Transient Generator)
60 Volt/60 Amp 120 Volt/30 Amp

Range (Remote only):
 1 Hz to 10 kHz 1 Hz to 10 kHz

Local Default:
 200 Hz 200 Hz

Duty Cycle Range (Remote Only):
 3% to 97% 3% to 97%

Local Default:
 50% 50%

Voltage Range:
 3V to 60V 3V to 120V

Resolution:
 20 mV 100 mV

Programmable Slew Rate:
 Four rates (see Four rates (see
 Current Pulse Current Pulse
 Mode) Mode)

Resistance Pulse Mode
(Transient Generator)
60 Volt/60 Amp 120 Volt/30 Amp

Range (Remote only):
 1 Hz to 10 kHz 1 Hz to 10 kHz

Local Default:
 200 Hz 200 Hz

Duty Cycle Range (Remote Only):
 3% to 97% 3% to 97%

Local Default:
 50% 50%

Resistance Range:
 0.01 to 99.99 Ω 0.1 to 999.9 Ω
 (Factor of 5 (Factor of 5
 max for large max for large
 currents) currents)

Resolution (Up to 10 Ω):
 0.01 Ω 0.1 Ω

Resolution (10 to 99.99 Ω):
 0.05 Ω 0.1 Ω

Resolution (100 to 999.9 Ω): 0.5 Ω

Programmable Slew Rate:
 Four rates (see Current Pulse Mode) Four rates (see Current Pulse Mode)

Short Circuit Mode

60 Volt/60 Amp 120 Volt/30 Amp

Equivalent Resistance:
 <0.05 Ω (0.025 Ω typical) <0.2 Ω (0.1 Ω typical)

Open Circuit

60 Volt/60 Amp 120 Volt/30 Amp

Equivalent Resistance (Open Relay Contacts):
 >10 MΩ >10 MΩ

Measurement System (TST Function)

60 Volt/60 Amp 120 Volt/30 Amp

Accuracy:
 0.5% of Full Scale 0.5% of Full Scale

Voltage Resolution:
 20 mV 100 mV

Current Resolution (High Range):
 20 mA 10 mA

Current Resolution (Low Range):
 2 mA 1 mA

Voltage Temperature Coefficient:
 50ppm/°C ±2mV/°C 50ppm/°C ±4mV/°C

Current Temperature Coefficient:
 50ppm/°C ±5mA/°C 50ppm/°C 5mA/°C

Protection Circuits

60 Volt/60 Amp 120 Volt/30 Amp

Over voltage:
 Shut down at 66V Shut down at 132V

Over power:
 110% of rated power (Steady-state) 110% of rated power

Reverse Sense Lead Protection:
 Shutdown Shutdown

General Specifications

60 Volt/60 Amp 120 Volt/30 Amp

Remote Sensing (Between Sense and Load Input):
 2.0 VDC Max 2.0 VDC Max

Operating Voltage:
 <1V at 10A <1V at 5A

Current Drift (over 8-hour interval):
 0.03% ±10 mA 0.03% ±10 mA

Voltage Drift (over 8-hour interval):
 0.01% ±10 mV 0.01% ±10 mV

Current PARD (20 Hz - 10 MHz Noise):
 4 mA RMS 4 mA RMS
 30 mA peak-to-peak 30 mA peak-to-peak

Voltage PARD (20 Hz - 10 MHz Noise):
 5 mV RMS 10 mV RMS

DC Isolation Voltage (Any input-to-input-to-chassis):
 ±240 VDC ±240 VDC

Operating Temperature:

Up to 40°C (104°F) at 300 Watts	Up to 30°C (104°F) at 300 Watts
---------------------------------------	---------------------------------------

Up to 40°C (104°F) at 200 Watts	Up to 40°C (104°F) at 200 Watts
---------------------------------------	---------------------------------------

**SPECIFICATIONS ARE SUBJECT TO CHANGE
WITHOUT NOTICE**

1.5 INPUT CONNECTOR DEFINITIONS

The input connector for DC loads at the rear of the chassis is defined as follows:

1.5.1 Terminal Block Version

Refer to Table 1-1 for Terminal Block definitions.

Table 1-1. Terminal Block Definitions

Terminal Block	Definition
Top Terminal	Positive Input Power
Second to Top Terminal	Positive Voltage Sense
Third to Top Terminal	Negative Voltage Sense
Bottom Terminal	Negative Input Power

1.5.2 MS Connector Version

Refer to Table 1-2 for MS pin numbers and their definitions, and to Table 1-3 for MS connector pin part numbers.

Table 1-2. MS Pin Number Definitions

MS Pin Number	Definition	MS Pin Number	Definition
A	Positive Input Power	E	Negative Input Power
B	Positive Input Power	F	Negative Input Power
C	Positive Input Power	G	Positive Voltage Sense
D	Negative Input Power	H	Negative Voltage Sense

Table 1-3. MS Connector Part Numbers

Connector	Part Number
Mating Connector	MS3106A22-23P
Chassis Connector	MS3102A22-23S

SECTION II

INSTALLATION

2.1 INTRODUCTION

The Model AT8000A is configured, calibrated, and tested prior to shipment. Therefore, this instrument is ready for immediate use upon receipt. The following initial physical inspections should be made to ensure that no damage had been sustained during shipment.

WARNING

Hazardous voltages are present when operating this equipment. Read the "SAFETY" notices on page ii prior to performing installation, operation, or maintenance.

CAUTION

Do NOT apply AC input voltage to this instrument nor connect any load(s) without first verifying correct input line voltage and output wiring configuration. This instrument and any external loads or cables may be damaged by improper voltage settings, mixing modules of different channels, cable mis-wiring, etc.

The user must become familiar with their particular Model AT8000A configuration. Unlike many instruments, the Model AT8000A may be a single or up to sixteen chassis system and be filled with up to 96 DC Power Modules of different voltage ranges and interconnect configurations.

In addition, the user's system may be configured with an Auxiliary Drive module or Electronic Load module(s).

The following topics and verification of the user's particular configuration are necessary prior to connecting cables and applying AC input power.

To simplify this process, the topics are arranged as:

- 2.2 Unpacking
- 2.3 Installation
- 2.4 Configuration
- 2.5 Rear Panel Switches and Connections
- 2.6 Processor Board Jumper Settings
- 2.7 Auxiliary Drive Module Installation and Configuration
- 2.8 Functional Verification

Appendix A contains information on Wire Gauge Selection. Appendix B contains the Configuration and Functional Verification Checksheet (photocopy and use this checksheet as required). The Checksheet simplifies the user's Model AT8000A configuration and functional verification process. It also serves as an ideal reference during application hookup and as a permanent maintenance record.

2.2 UNPACKING

2.2.1 Inspecting The Package

Inspect the shipping container before accepting the container from the carrier. If damage to the container is evident, remove the instrument from the container and visually inspect it for damage to the instrument case and parts.

If damage to the instrument is evident, a description of the damage should be noted on the carrier's receipt and signed by the driver or carrier agent. Save all shipping containers and material for inspection.

Forward a report of any damage to the Elgar Repair Department, 9250 Brown Deer Road, San Diego, CA 92121-2294. Elgar will provide instructions for repair or replacement of the instrument.

Retain the original packing container should subsequent repacking for return to the factory be required. Repacking is straightforward and is essentially the reverse of unpacking. Should only a subassembly need to be repackaged for re-shipment, use the original containers. Elgar will provide shipping instructions and containers, if necessary.

2.2.2 Pre-Installation Inspection

Inspect the instrument and associated modules (if any were shipped separately) for shipping damage such as dents, scratches, or distortion.

Remove the modules from their shipping containers and inspect each one for damage. There is no need to remove any module already installed in any chassis drawer unless damage is suspected.

Check the rear of the instrument for damage to the connectors.

2.3 INSTALLATION

The Model AT8000A is 5.25" (133.35mm) high and is designed to be installed in a standard 19" (483mm) rack cabinet. The instrument chassis is pre-drilled for rack slide mounting. Rack slides are recommended for periodic maintenance since all normal adjustments are accessible via the instrument top cover. Rack slides are available from Elgar.

WARNING

When rack mounting the AT8000A, **DO NOT** use screws that protrude into the chassis of the AT8000A more than 0.30" (7.6mm). Longer screws will short internal components to the chassis, causing the AT8000A to malfunction.

CAUTION

Avoid blocking instrument air intakes or exhaust.

Both instrument air intakes are located on the sides near the chassis front. Exhaust is past the heat sinks to the whole rear panel. Avoid blocking these intakes and exhaust. No special vertical separation is required when stacking instruments. However, a 1.75" (44.45mm) vertical space above and below the instrument may improve air intake circulation. Figure 2-1 depicts the location of air intakes, air exhaust, and rack mounting while Figure 2-12 provides the location of the various switches and connectors.

2.3.1 DC Module/Electronic Load Module Installation

This topic applies only if the Power Modules and/or Electronic Load Modules were shipped individually.

NOTE

The following information addresses DC Power Module installation. Electronic Load Module installation is similar.

Determine which DC Power Modules are to be installed in which channels. Module voltage range is marked on the side of the power transformer towards the front of the module as identified on Figure 2-3.

Install the DC Power Modules by aligning them with the connector towards the rear of the instrument (refer to Figure 2-4). Then place the module on the bottom card guide. While holding the module vertically, slide it towards the chassis rear until the connector is fully engaged.

After all modules are installed, secure them from sliding back out by installing the two top support brackets. Each bracket has multiple narrow slots to fit the top edge slots of each module.

NOTE

Proper installation with these support brackets is most important to prevent the heavy DC Power Modules from creeping out of their rear backplane connectors.

2.3.2 Master/Slave Modules

A master/slave module combination is a set of two to six DC Power Modules internally connected together to function as a single channel. One master module is required for each channel. One or more (up to five) slave modules may be installed to inter-connect with its respective master module for increased output current (power).

A master module is identified by verifying the presence of integrated circuits U7, U8, U18, U19, and U21 on its DAC board (top most board on the module). Slave modules obtain their programming via a flat ribbon cable from their respective master modules and not from the processor directly. Thus, slave modules do not have these particular integrated circuits installed. Master modules may be factory modified to become slave modules (refer to Figure 2-5).

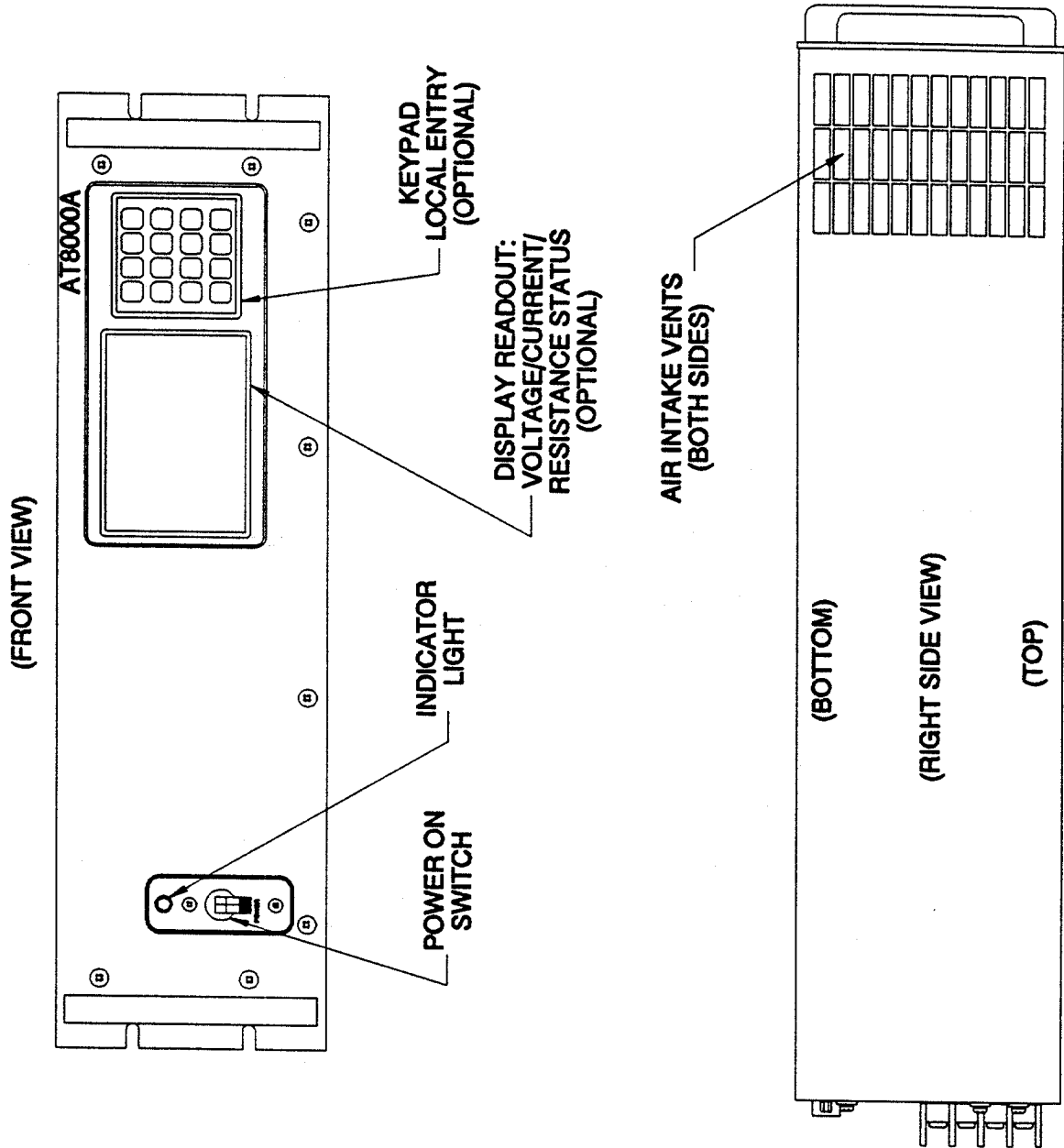

Figure 2-1. Model AT8000A (Front and Side Views)

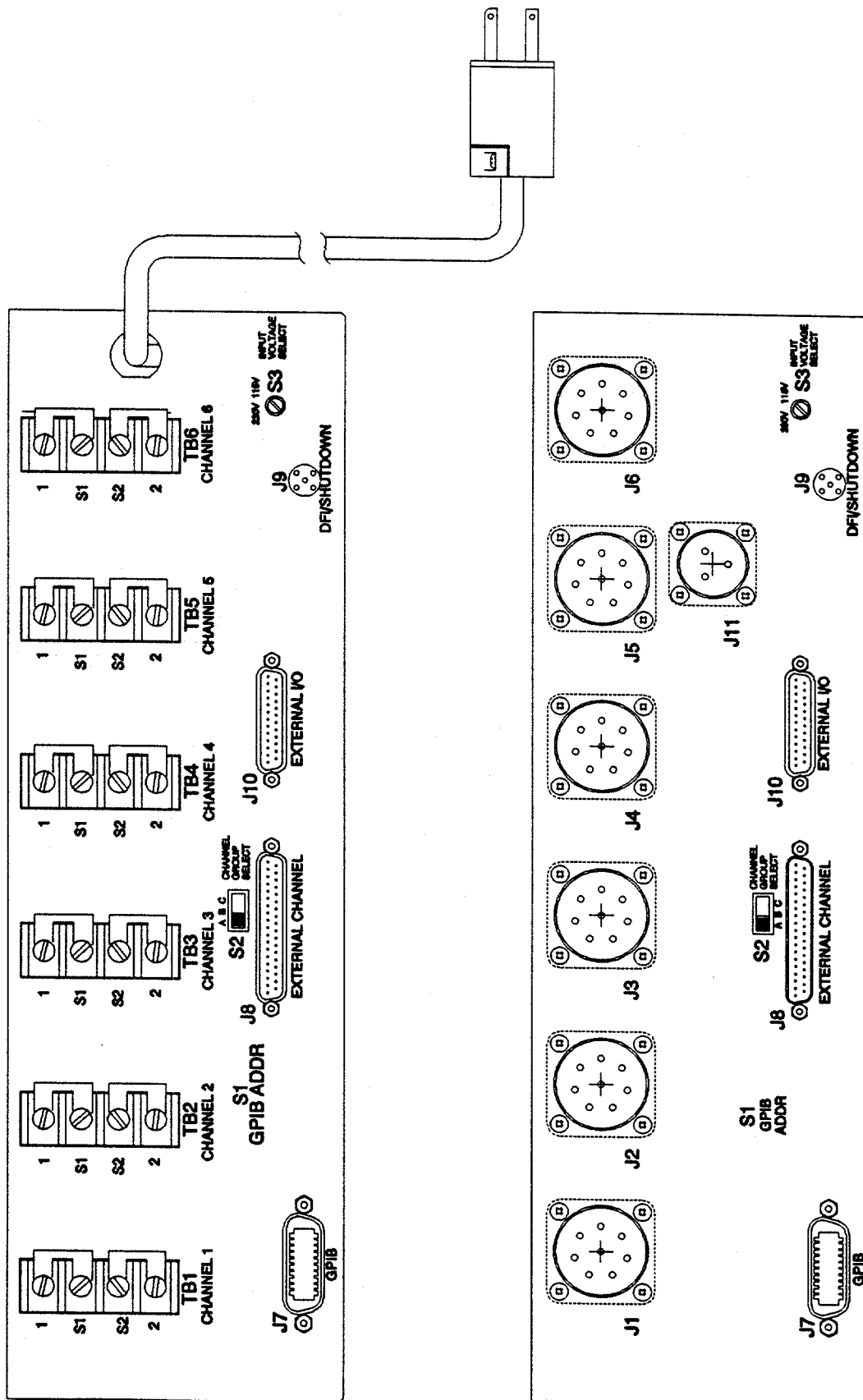

Figure 2-2. Model AT8000A (Rear Views)

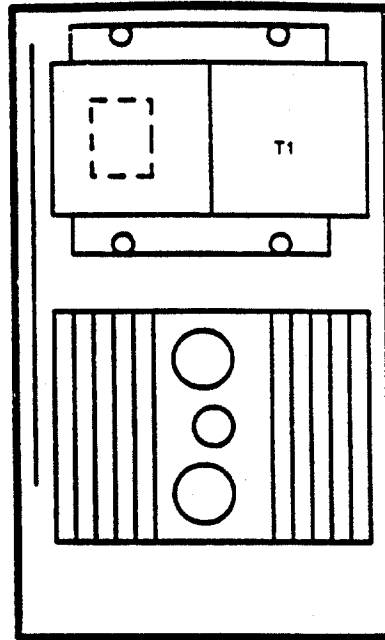

Figure 2-3. DC Power Module Identification

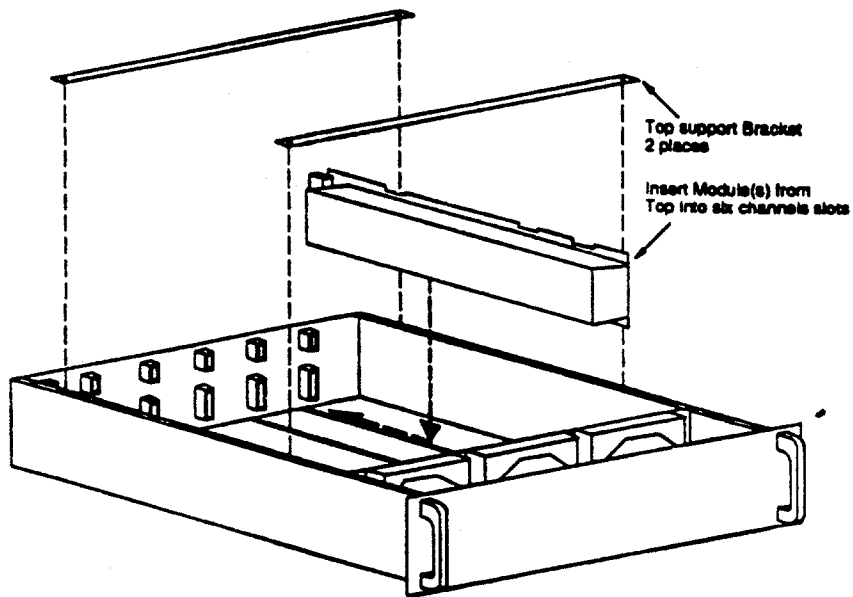

Figure 2-4. DC Power Module Installation

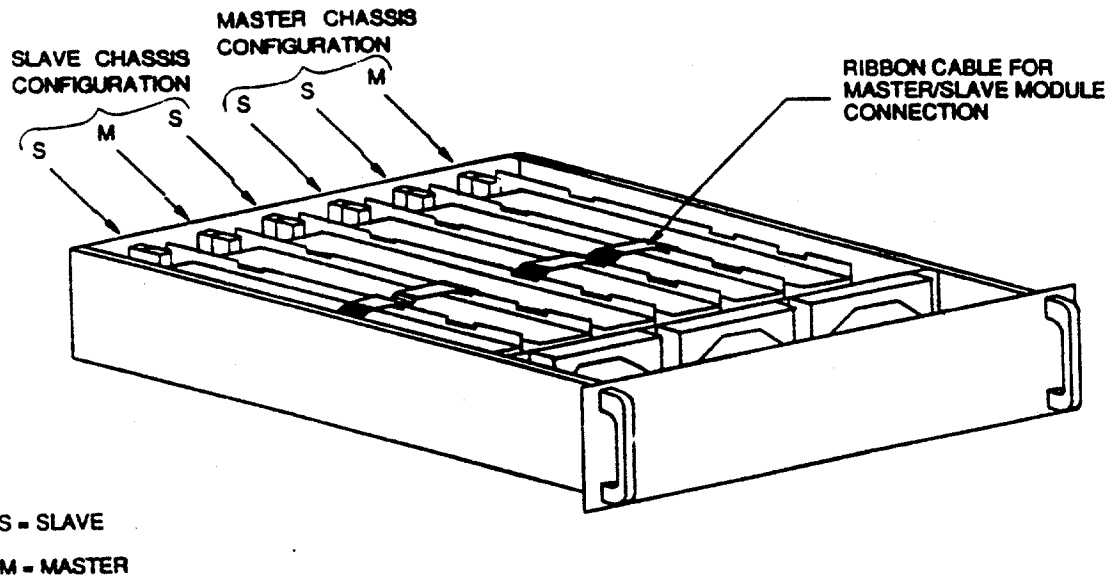

Figure 2-5. DC Power Module Master/Slave Connections

The master/slave combination should be installed into adjacent channel number slots to minimize the length of ribbon cable connecting the modules together. A master module may be installed in any slot relative to its slave modules. A ribbon cable carries programming information from the master module to its corresponding slave modules via their respective J1 IC socket connectors. No output power is present on the ribbon cable.

The location of the master module determines the channel number of the master/slave combination. If a master DC Power Module is installed in slot 1, then its channel assignment is channel 1. Similarly, a master installed in slot 2 yields channel 2, etc. A slave module uses the channel assignment of its corresponding master, regardless of which slot the slave occupies.

Should the user's Model AT8000A have one or more expansion chassis drawers, the user will want to verify or set the Channel Group Select Switch located on the rear of the respective chassis. The master chassis processor supports 16 channels no matter how many extension drawers are used. Each channel assignment is determined by the placement of a master module. Slots 1 through 6 correspond to channels 1 through 6, respectively, when the Channel Group Select Switch is set to position "A".

To obtain channel assignments 7 through 12, merely set the corresponding Group Select Switch to position "B". Similarly, position "C" corresponds to channels 13 through 16.

It is normal to have any two or more chassis drawers set to the same Group Select Switch position provided that master modules are not placed in identical slot numbers. There is no channel conflict concern if a master of one chassis occupies the same slot as a slave of another chassis. Repeating, a master module slot together with its chassis Group Select Switch determines the channel assignment. An example of this master/slave channel assignment is in Figure 2-6.

The outputs of the master/slave modules must be connected together in parallel at their respective output terminals and thus provide current that is equal to the current of a single module multiplied by the number of modules in the master/slave combination. This configuration is limited to modules of identical voltage and current characteristics. The remote sense input should be connected only to the master module because it alone senses remotely and regulates both itself and associated slave modules. The remote sense inputs of slave modules are not used.

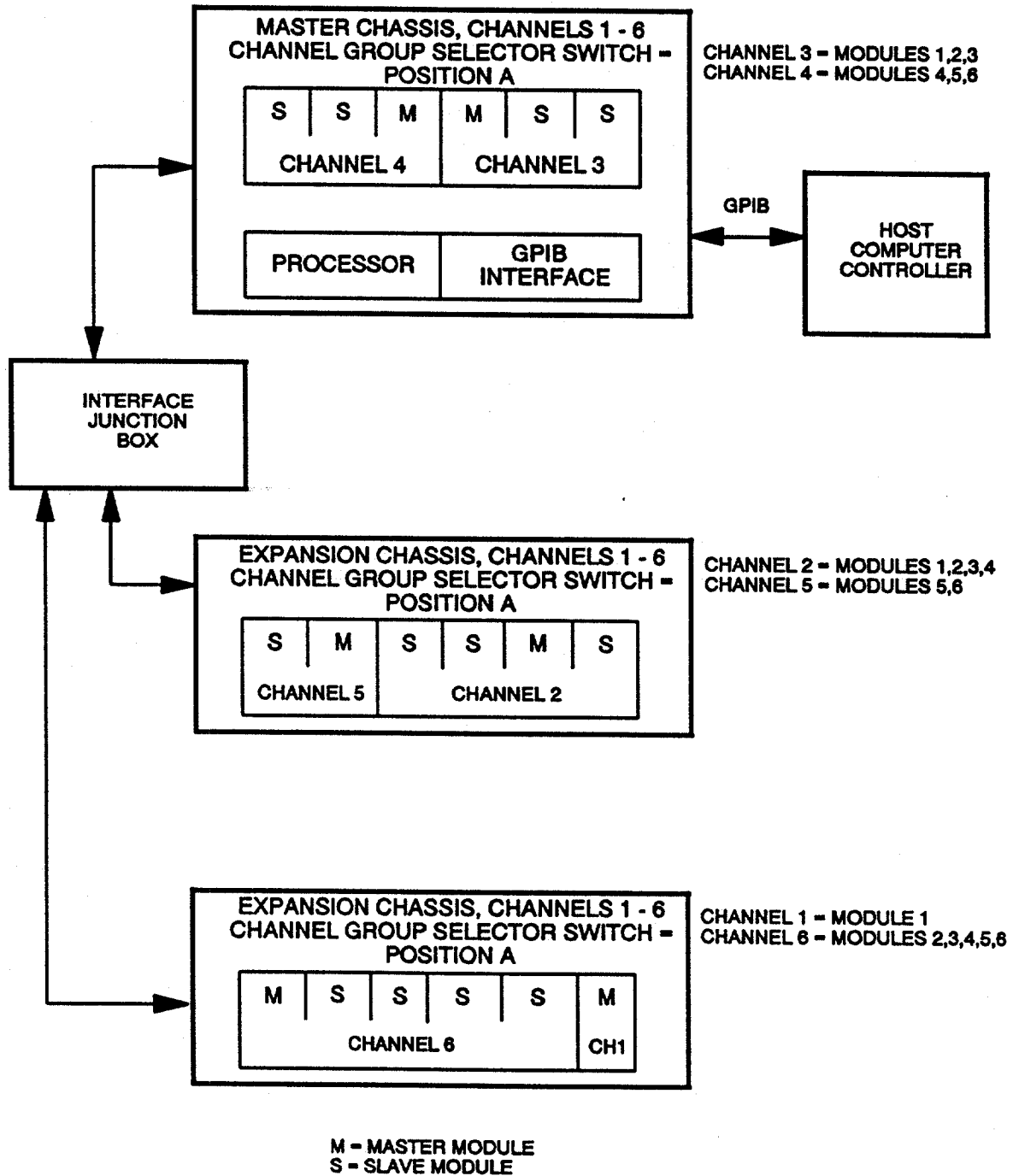

Figure 2-6. Master/Slave Modules

2.3.3 Dummy Modules

A dummy module consists of a vertical board configured as an air flow restrictor. The module plugs into the chassis bottom slot and fits into the top brackets as any other module, except that the module has no electrical connections.

Dummy modules are installed when a chassis is not otherwise fully loaded with six DC Power Modules. Dummy modules redirect forced cooling air towards the real DC Power Module heat sinks and not through the empty space of the chassis.

2.3.4 DC Power Module Output Relays

Each DC Power Module has three sets of output relays: sense, isolation, and polarity. Sense and isolation relays are standard; the polarity relay is optional. These relays are both front panel and remotely programmable. They also automatically respond to fault conditions.

The sense relay selects either external or internal voltage sensing for channel voltage regulation and Test (monitoring).

The output isolation relay connects or removes (isolates) the DC Power Module output from the User Load.

The reverse polarity relay inverts the output voltage (and sense polarity) upon command. This provides both plus and minus polarity.

This optional relay, if installed, also has jumper W9 installed on the DC Power Module DAC Board.

2.4 CONFIGURATION

The Model AT8000A System may be factory or field configured to meet any ATE requirement. The Model AT8000A includes a processor, optional front panel keyboard and display, optional BIT (Built In Test) capability, a remote programming interface via GPIB, and up to six DC power/electronic load channels – all within a single 5.25" (133.35mm) rack-mountable chassis.

For simple applications, each slot within the chassis may be dedicated to an individual DC power supply or electronic load channel. The DC Power Modules are available in eight ranges from 0 to 7 VDC on up to 0 to 320 VDC and power levels from 105 watts to 200 watts each.

In more complex test systems or burn in applications, the Model AT8000A controls up to sixteen DC power channels of up to 1200 watts each, or 1800 watts of DC loads. Each channel consists of one DC Power Module, or more, connected internally by a ribbon cable as "master/slave". The outputs of the "master/slaves" are externally paralleled for additive output current. Additional chassis drawers may be added with all being controlled by the same intelligent chassis electronics above for a total of 96 power modules or 19.2 kilowatts.

2.4.1 Basic System

A basic Model AT8000A System consists of one through sixteen output channels controlled by the master chassis either from its front panel or remotely via the GPIB. Only one GPIB Address (set at the master chassis) is used, regardless of the number of channels installed or the number of chassis used.

The sixteen channel numbers are logically divided into three channel groups:

- Group A = Channels 1 through 6
- Group B = Channels 7 through 12
- Group C = Channels 13 through 16

These groups are set via the Channel Group Select switch (S2) located on the rear panel (refer to paragraph 2-5 for further details).

Each 5.25" (133.35mm) high chassis contains up to six modules and is switch selectable for any channel group. A simplified 16 channel system in three chassis is illustrated in Figure 2-7. Chassis A is the master chassis containing the GPIB interface, processor, and six 200 watt modules individually addressed and selected to be channel group 1-6. Chassis B contains six modules and selected to be channel group 7-12. Chassis C contains channel group 13-16.

2.4.2 Complex System

The Model AT8000A's unique "master/slave" module capability coupled with "master/extender" chassis capability and intelligent internal processor enables more complex DC power applications. The example of Figure 2-8 demonstrates some of this flexibility of the Model AT8000A system.

Channel groups are not restricted to a single chassis. Figure 2-8 shows channel group 1-6 configured for three separate chassis, A1, A2, and A3. The Channel Group Select Switch is set identically in each chassis to position A. Channel group 7-12 is configured only for chassis four, but could be configured with as many as six chassis with up to six modules each. Channel group C is configured for chassis five as three single module channels with channel 16 consisting of three modules.

2.4.3 Make Extender Chassis From Master Chassis

A master chassis can be used as an extender chassis and controlled by another master chassis. By placing the back panel GPIB address switch to address 31 (never used, GPIB illegal address, all 5 switches set to ON or 1 position), a master chassis will behave as an Extender chassis. The code number 71 will appear on the channel number display to indicate the slave chassis mode.

This is useful for users who have different test configurations, but want the flexibility of using only one type of chassis as either master or extender. This also minimizes user stock requirements.

2.4.4 Emergency Shutdown Input Panic Button

This feature provides the capability of shutting down the entire AT8000A system by means of an externally driven signal.

All channels are programmed to zero volts, zero current and all the relays are opened (same as power up quiescent conditions) when the input pins (DFI pins D and E) are shorted together. This can be initiated by the controller or by a manual button.

These pins should be shorted by isolated relay contacts so the AT8000A is not connected electrically to noise or external voltages. One of the pins is the processor board digital ground and the other is the +5V power pin pulled up through a 33 k Ω resistor. By shorting the two signals, the processor reads the normally high pulled up signal as a logic zero and initiates the shut down.

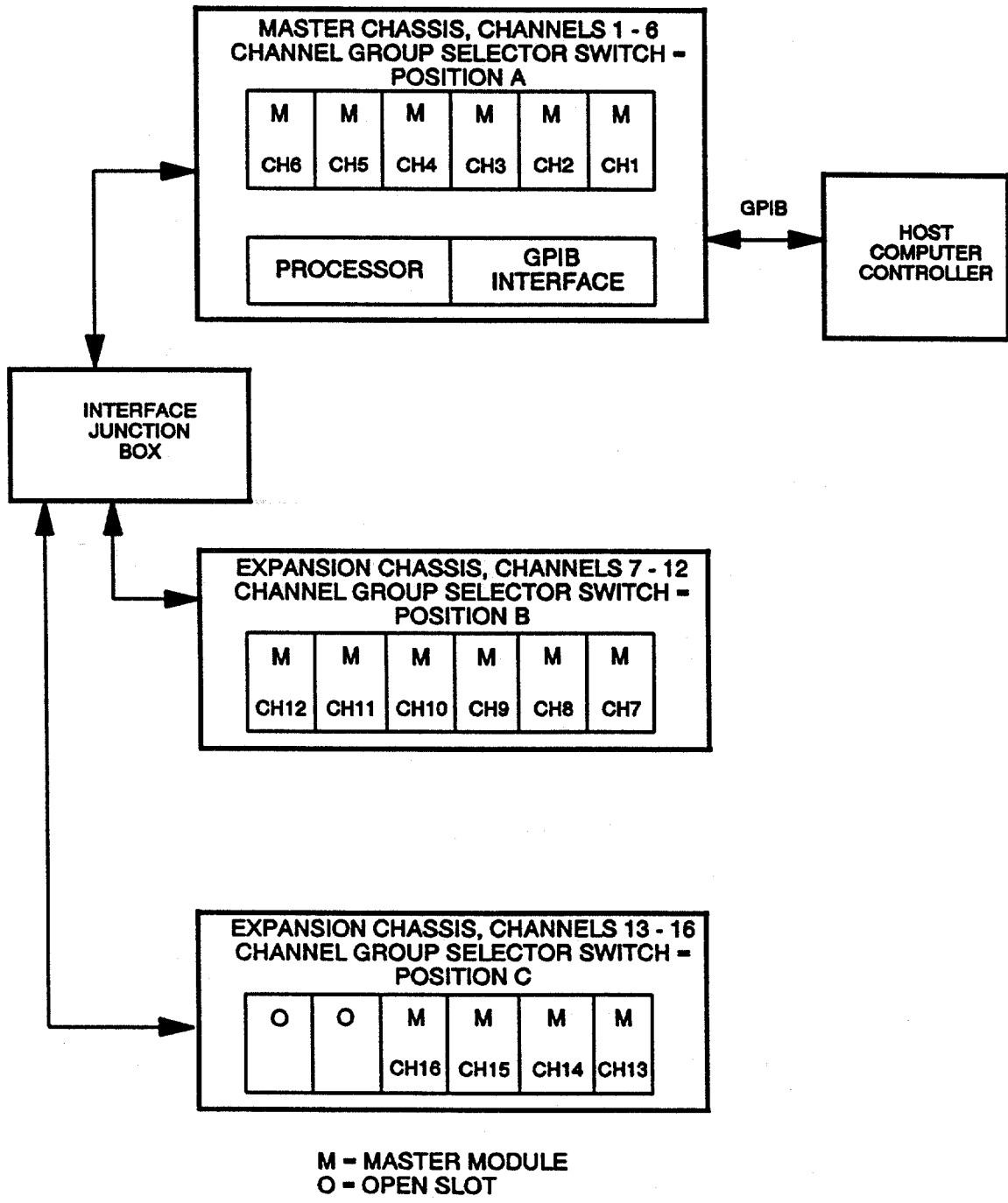

Figure 2-7. Basic System Configuration

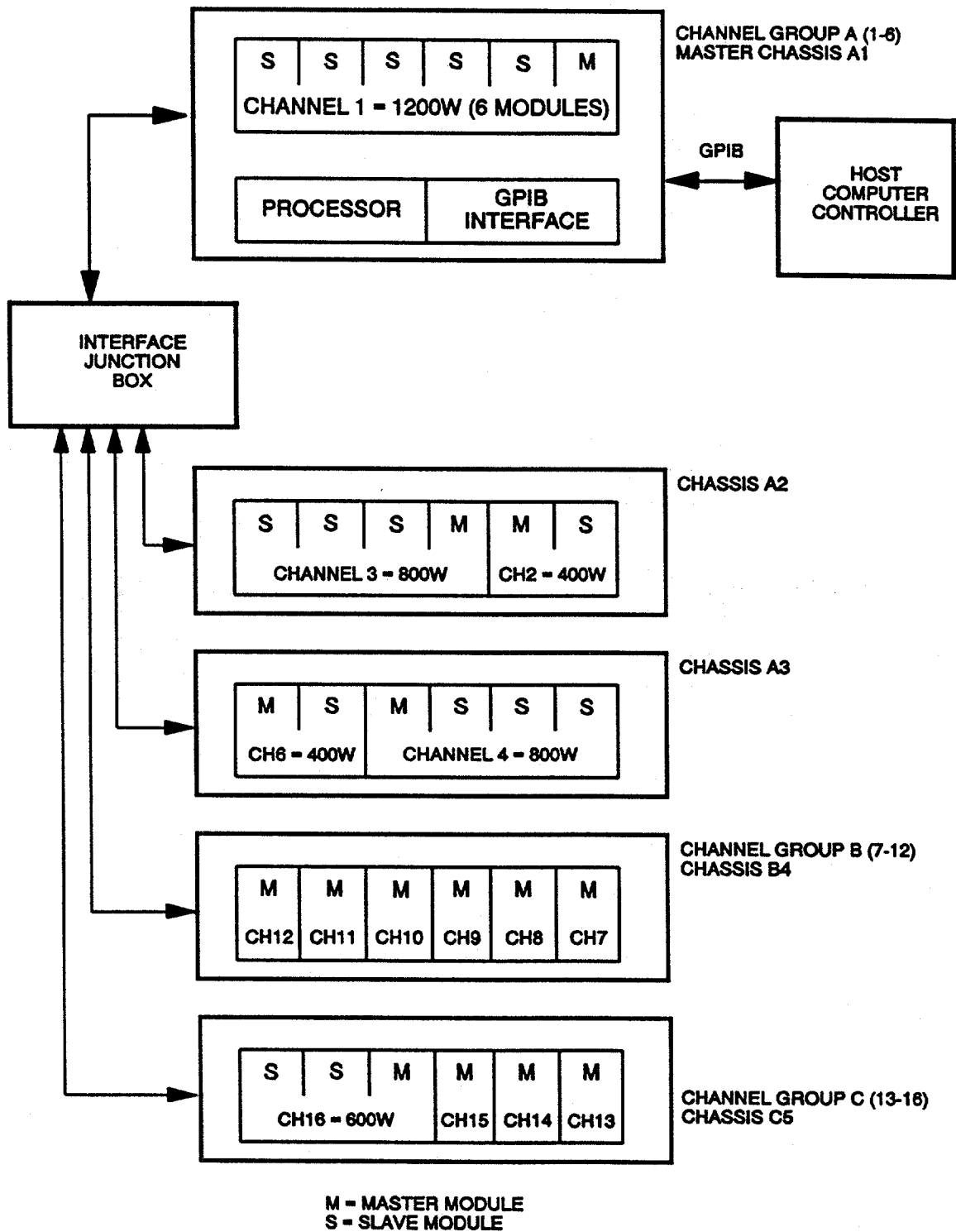

Figure 2-8. Complex System Configuration

2.4.5 Series Operation

Any master module may have its output connected in series with other master modules to achieve higher output voltages. The only restriction to this configuration is that the Maximum Voltage Difference Between Any Channels or Chassis Must Be Limited To 400 Volts. Should the user's application require additional float capability, consult the factory. Sense terminals should also be connected in series between the channels with the top and bottom lines connected to the load as in Figure 2-9.

For optimum load regulation in series configurations, sense line resistors should be inserted across the sense lines at the load end of the cable. These resistors do not need to dissipate more than 1 Watt and should be selected on the basis of the voltage across them. The resistors must, however, all be of the same resistance value. This improved series channel configuration is depicted in Figure 2-10.

In any series configuration, the lowest maximum current of any channel sets the maximum current for the series combination. That is, when a 10 A channel is connected in series with a 5 A channel, the maximum current capability of the combination is 5 A.

In Current Limit (CURL), there is normal constant voltage with an upper limit of current, and only one channel in the series combination needs to be programmed in the Current Limit mode. However, all channels in the series combination may be programmed in the Current Limit mode.

In Constant Current (CURR), there is normal constant current but voltage varies, and all channels in the series combination must be programmed in the Constant Current mode.

The programming sequence for series operation channels is no different than for normal stand-alone channels.

A channel, as depicted in the two previous figures, may consist of the following:

- A single master module, or
- A master/slave module combination operating as a single channel and consisting of two to six modules, or
- Multiple master modules operating in parallel with the Parallel command. In this case, each master module had its own separate channel number. Parallel configuration is described next.

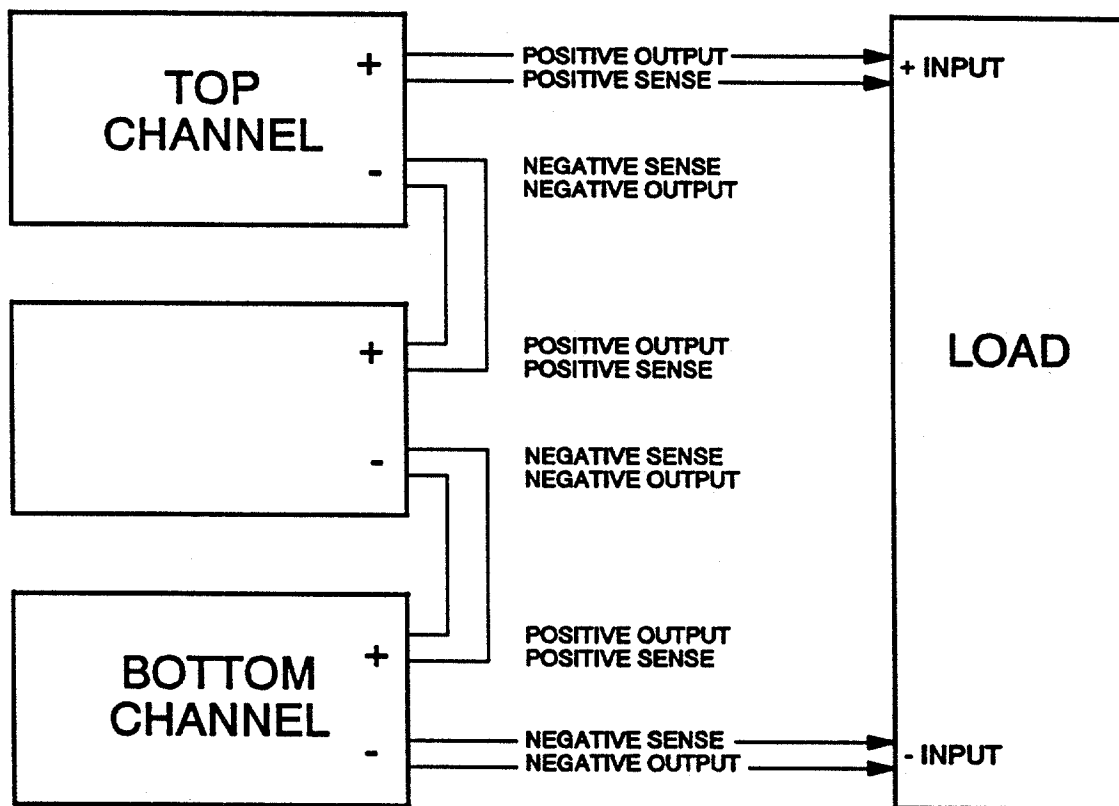

Figure 2-9. System Series Operation

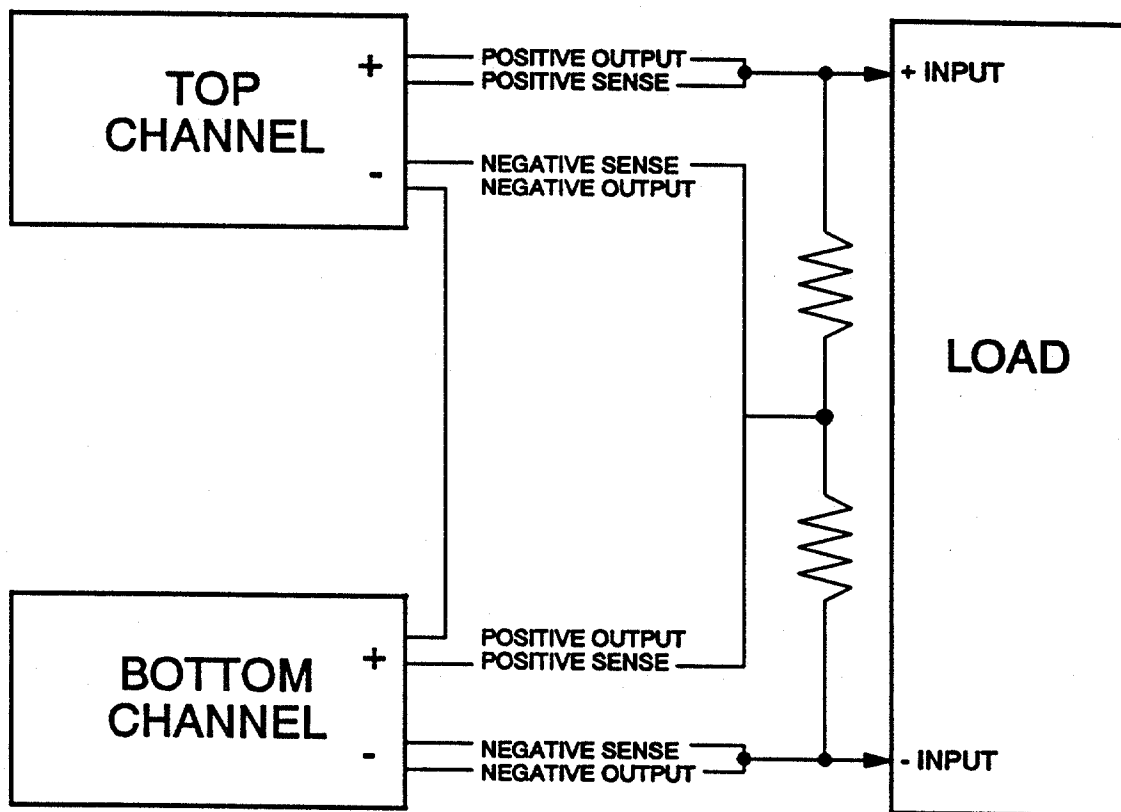

Figure 2-10. System Series Operation - Better Regulation

2.4.6 Parallel Operation With Master/Slaves

A channel of a master/slave parallel combination consists of one master DC Power Module with up to five slave DC Power Modules. These modules are internally connected together with a ribbon cable. The location of the master module determines the channel number of the master/slave combination. Only the master DC Power Modules sense the output voltage and current and regulates themselves and all the slave modules. Sense terminals of the slave modules are not used.

A master/slave channel is programmed and responds exactly as a normal single standard master module. The only difference is its higher output current capability. The master/slave output and sense terminal connections are depicted in Figure 2-11.

2.4.7 Parallel Operation With Standard Masters

Separate DC channels, with or without slaves, may be connected and used in parallel operation when higher output current is desired.

The following restrictions should be observed:

1. All channels in the parallel combination **MUST** be programmed into the same group. If a channel in the parallel combination crowbars, it will try to sink all the current from the other paralleled channels possibly resulting in damage to the crowbarred channel. Therefore, when a channel shuts itself down due to a failure, it is important to simultaneously shut-down all other channels in the parallel combination.
2. All channels in the parallel combination **MUST** have their voltages programmed to the same value.
3. If external voltage sensing is desired, the sense relay should be programmed for external sensing only after the channels are programmed and their output isolation relays have been closed.

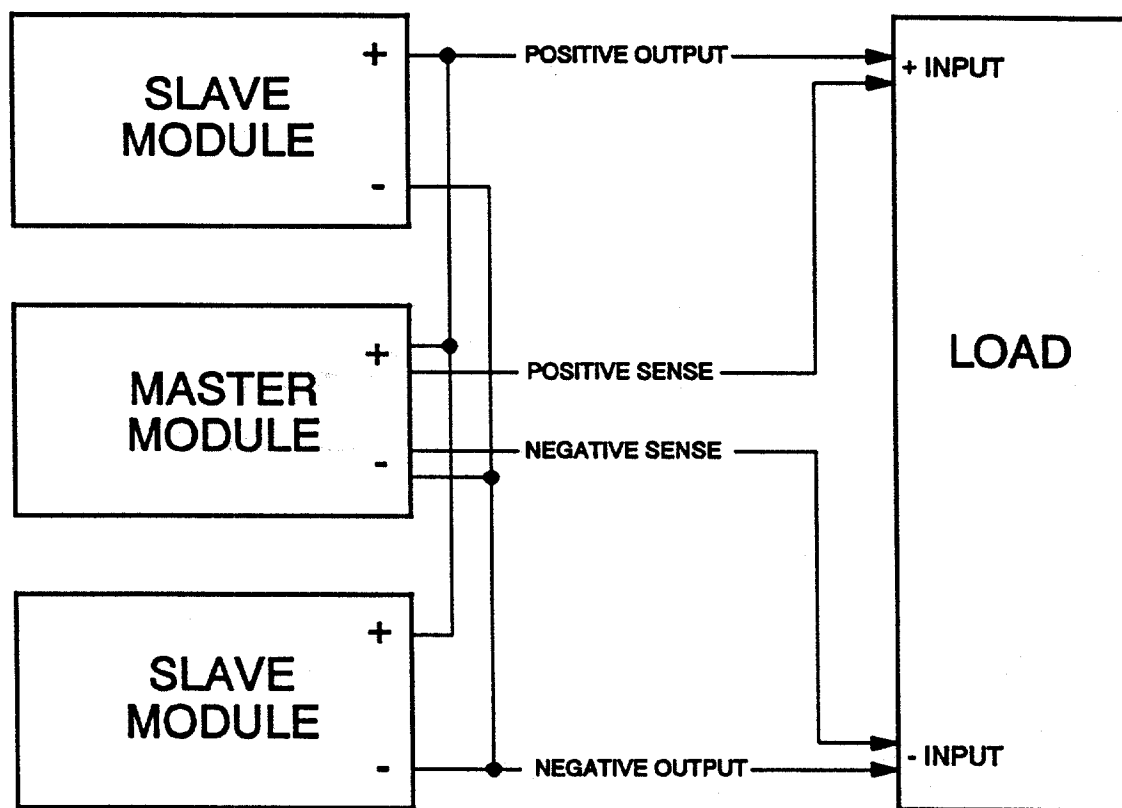

Figure 2-11. System Parallel Operation

There are three ways to parallel channels:

Method 1: Paralleling Using the "PAR" ABLE or CIIL Language Command.

This is the recommended and easiest method of paralleling channels in the current limit mode. It is available when using the remote controller in the ABLE or CIIL programming language.

Once the Model AT8000A processor receives the PAR command, it waits until all channels specified the PAR command are in current limit before it will issue a current limit failure and shut down the channels. For this reason, it should never be used with channels that are programmed in constant current mode (CURR).

CAUTION

CURR Channel in parallel.

If the PAR command is used with at least one channel in the constant current (CURR) mode, the processor waits until all channels reach the CURL mode current limit before shutting down. Since the channel programmed for constant current (CURR) never reaches current limit, this essentially puts all channels specified in the PAR command in the constant current mode which will never shut down due to current limit failure. This may result in damage to the load due to over-current for an extended amount of time. Therefore, avoid using CURR mode with Paralleling channels where possible.

NOTE

The PAR command, like the GRP command, is automatically reset whenever a run time fault occurs on that channel, a RST command is sent, a CNF test is performed, or the Model AT8000A is powered down. The PAR command must be re-sent after any of these events have occurred.

Remote Paralleling Example:

To remotely parallel a 20 Volt/10 Ampere module installed in channel 1 with a 20 Volt/10 Ampere module installed in channel 2, the maximum voltage of the pair can be 20 Volts and the maximum current can be 20 Amperes.

NOTE

Only modules of the same voltage rating can be paralleled.

The programming sequence should be similar to the following. Note the liberal use of serial poll to assure no syntax or other errors. Use WAIT judiciously to allow the instrument to process GPIB instructions and relays to settle. It is not required to CLS the isolation relays simultaneously as shown below. The two OPN commands could be replaced by CLS.

OUTPUT 717 "CNF"

Perform Confidence Test.

WAIT 500

CNF requires about 70ms plus additional 70ms per installed channel.

A=SPOLL(717)

Perform GPIB Serial Poll and return byte.

DISP A

0 = AOK on CNF Test. Refer to Section III if not.

OUTPUT 717 "GRP 1,2"

Assign channels 1 and 2 into the same group set.

A=SPOLL (717)

Verify if GRP assignment is AOK.

DISP A

0 = AOK

OUTPUT 717 "CH1 VOLT 20 CURL 10 SENS;OPN"

Set up channel 1 with internal sense.

OUTPUT 717 "CH2 VOLT 20 CURL 10 SENS;OPN"

Set up channel 2.

A=SPOLL(717)

Check for any errors.

DISP A

0 = AOK

OUTPUT 717 "CH1 CLS, CH2 CLS"

Connect outputs simultaneously.

A=SPOLL(717)

Check instrument.

DISP A

0 = AOK

OUTPUT 717 "CH1 SENS X, CH2 SENS X"

Now use external sense.

A=SPOLL(717)

Check instrument.

DISP A

0 = AOK

Method 2: Paralleling For Current Limit Without The PAR Command.

The problem in paralleling channels in current limit (CURL) is the inherent slight unbalance in output current. One channel will provide its full programmed current and shut down due to current limit slightly before the second channel can provide its own current.

To overcome this problem, the user must find which channel is the last to provide the output current. This channel is then the only channel to be programmed in the current limit (CURL) mode and all other channels must be programmed in the constant current (CURR) mode. The disadvantage of this method is that most channels (except 7 and 10 volt modules) lose 40% of their output current capability when programmed in constant current (CURR) mode.

To find the lazy channel, program all the channels to be paralleled in the current limit (CURL) mode and close their output relays with the load applied. When this is done, at least one of the channels is going to fail due to a current limit condition. This (these) channel(s) must then be programmed in the constant current (CURR) mode.

This procedure should be repeated until only one channel remains in the current limit (CURL) mode.

Method 3: Paralleling Channels in Constant Current (CURR) Mode.

There are no special procedures required when paralleling channels in the constant current (CURR) mode. There is no advantage in using the PAR command in CURR. A disadvantage is that most channels (except 7 and 10 volt modules) lose 40% of their output current capability when programmed in the constant current (CURR) mode.

Simply program all channels to the same voltage in constant current (CURR) mode and close their output relays. If external sensing is desired, close the external sense relays after the isolation relays have been closed.

2.5 REAR PANEL SWITCHES AND CONNECTIONS

2.5.1 Load Connections

Each Model AT8000A DC Power Module has its own output power and voltage sense terminals (or MS connector pin assignment). These connections are on the chassis rear on a slot-by-slot basis.

The optional polarity relay automatically switches the output voltage and sense leads whenever a minus polarity is programmed. Rear panel positive/negative signals are internally reversed.

Electrically, the terminal and MS connector versions are identical as depicted in Figures 2-12 and 2-13. Elgar ships one mating set of connectors for MS versions.

Terminal Block (Standard)

<u>Terminal</u>	<u>Definition</u>
Top-most	Positive Output
2nd from top	Positive External Sense
3rd from top	Negative External Sense
Bottom-most	Negative Output

MS Connector (Optional)

Refer to Table 1-2 on page 1-15.

Any channel using only a single DC Power Module, uses both the output power and sense lead connections. Slave module sense leads are never used. A channel uses only the sense leads of its master module.

In master/slave combinations, output power terminals are paralleled via heavy gauge wire or a buss bar for increased current (power). The sense terminals are NOT paralleled. In this combination, only the master module sense lead circuit is used.

More complex configurations involve DC Power Module combinations in series, series-parallel, and possible channel groups (GRP command).

The User/Installer needs to understand the previous topic examples as well as the particular User application prior to making output and sense connections.

Selection of output power and sense line cabling should follow good practice specific to the application. An output cable should be able to carry the full output load current and maximum voltage under worst case conditions of temperature, humidity, mechanical abuse, and effects of long term aging. The sense cable has comparable requirements, but the sense current requires a smaller wire gauge. Sense line shielding from stray pickup is more rigorous. General guidelines for designing/specifying these cables are included in Appendix A.

CAUTION

THE MAXIMUM VOLTAGE BETWEEN ANY CHANNELS OR THE CHASSIS MUST BE LIMITED TO 400 VOLTS. Should the user's application require additional float capability, consult the factory.

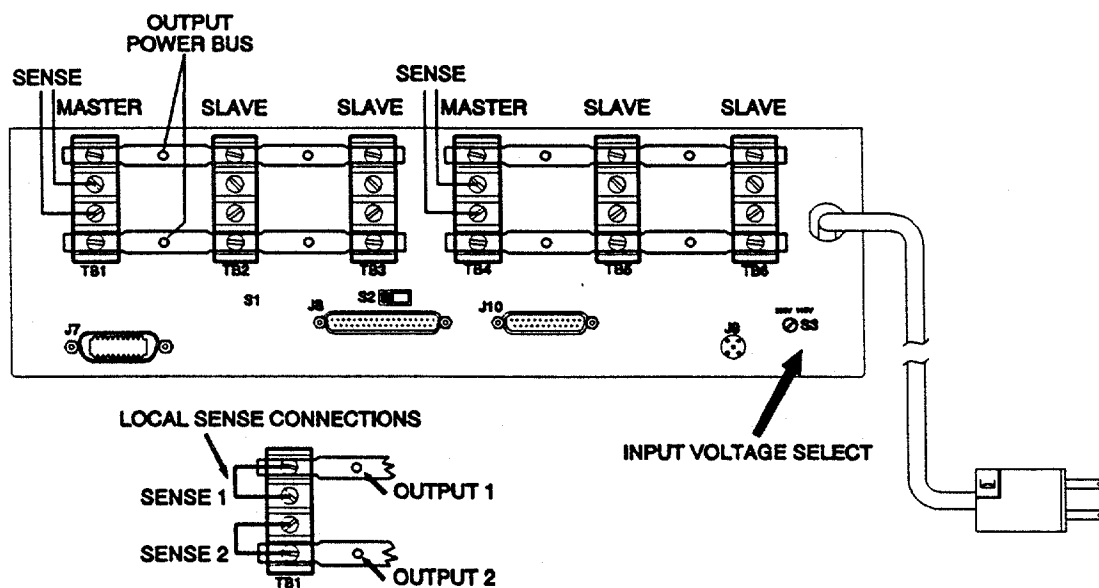
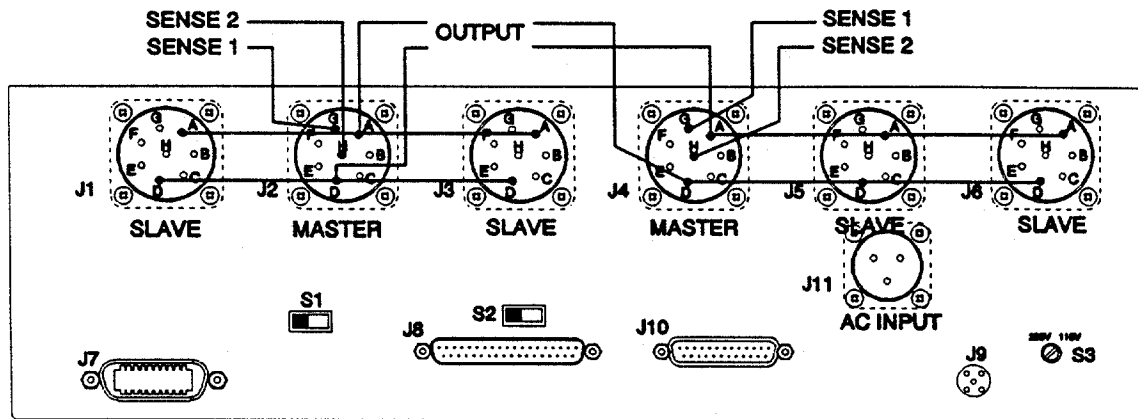

Figure 2-12. Interconnect Two Master/Slave Channels



A,B,C and D,E,F are common pins that will accept up to #12 AWG. The amount of current should determine whether all or some of the parallel pins need to be used. Sense lines only need to come from the Master Module(s).

Figure 2-13. Chassis Rear View, Two Master/Slave Channels

If sense lines are not externally connected, the Model AT8000A individual channels still regulate output voltage due to internal voltage sense sampling within the master module(s). However, as output current load increases, a channel's internal sense sample is not able to accurately correct for possible IR losses within the output power cable. External voltage sensing at the User load is always preferred, when possible, to cancel the adverse effects of cable losses.

A typical cable installation is depicted in Figure 2-14.

NOTE

The Model AT8000A is capable of generating high voltages at its output terminals under normal conditions. The installer **MUST** ensure that all cables, sense resistors, bypass capacitors, User Load Terminal strips/connectors, etc. are all properly labeled as to the **HAZARDS TO HUMAN SAFETY**, as applicable.

2.5.2 AC Input Power

The Model AT8000A is operated from nominal 115 VAC or 230 VAC power lines. From the factory, the unit should already be configured for the user's local AC line voltage and power connector requirements.

The AC line Input Voltage Select Switch (S3) as shown in Figures 2-12 and 2-13, is located on the rear panel of each chassis.

A simple screwdriver is all that is required to select the desired AC line input voltage (115/230 VAC). This same switch is used for both Terminal Block and MS Connector versions. No additional AC Input voltage selection is necessary for the DC Power Modules.

The AC input line ground wire provides safety ground for the instrument chassis.

Standard connector version is a six foot long AC input power cable hardwired into the rear of the chassis. The other end of the power cable is a three terminal twenty ampere male connector labeled NEMA 5-20 (or NEMA 5-20P). This appears very similar to the household NEMA 5-15 (115 VAC, 15 ampere) plug, except one pin is turned 90° to indicate its 20 ampere rating. Each chassis has its own separate AC power cable.

Mating receptacle is a NEMA 5-20R (115 VAC, 20 ampere) receptacle, which accepts both 15 and 20 ampere NEMA plugs.

CAUTION

DO NOT SELECT LINE VOLTAGE VIA S3 WHILE THE INSTRUMENT IS PLUGGED INTO AC POWER LINES.

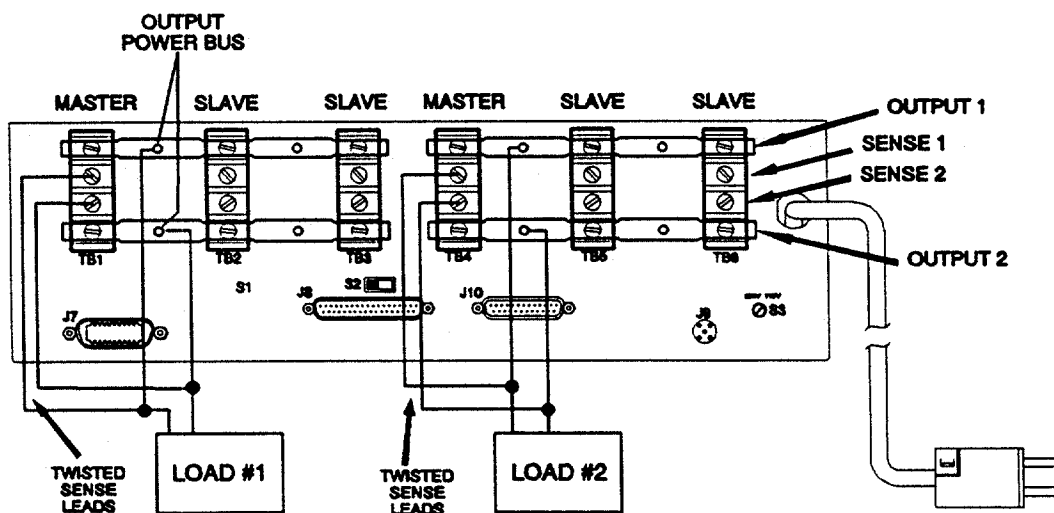

Figure 2-14. Load and Sense Connections

The MS Connector version is optional and may be required on certain military systems for both AC input power and channel outputs. AC input power uses the MS3102A-16-10P male connector mounted on the rear of the chassis as shown in Figure 2-12. One is required per chassis.

Elgar furnishes one mating connector (MS3106-16-10S, strain relief MS3057-8A-1). These MS connector components are available from Elgar. Customer furnishes own cable and AC plug.

2.5.3 MS Connector AC Input Line Connectors

<u>Pin</u>	<u>Definition</u>
A	Line (BLK)
B	Line (WHT)
C	Ground (GRN), chassis

2.5.4 IEEE-488 Interface

Remote programming, both ABLE and CIIL, use the standard 24-pin female IEEE-488 (GPIB - General Purpose Interface Bus) connector on the rear of the master chassis drawer. No additional GPIB cable is installed to the extender chassis(s) since the master chassis processor communicates from master chassis to each extender chassis via its own 37-pin connector cable(s). GPIB cables are available from Elgar.

Adjacent to the GPIB connector, as depicted in Figure 2-15, is an internally mounted rear panel 5-bit DIP switch. This is the GPIB listen address switch. From the factory, this is set to decimal address 17, as shown in Figure 2-15, but it may be readily changed by the User.

The DIP switch GPIB address is valid for Model AT8000A remote programming regardless of the number of channels installed.

The GPIB address DIP switch may be set to any address from 0 through 30, as per Table 2-1. An UP or ON is interpreted as a logical 1 by the internal processor. AC power must be recycled after changing this DIP switch since it is read only once, during power up.

Remote programming via the GPIB for both ABLE or CIIL languages is covered in Section III.

NOTE

The GPIB address DIP switch may be used to make an extender chassis from a master chassis.

Table 2-1 identifies switch setting for various addresses.

Table 2-1. GPIB Listen Address Settings

ASCII CHARACTER	HEX	DEC	GPIB LISTEN ADDR				
			1	2	3	4	5
<SP>	00	0	0	0	0	0	0
!	01	1	1	0	0	0	0
"	02	2	0	1	0	0	0
#	03	3	1	1	0	0	0
\$	04	4	0	0	1	0	0
%	05	5	1	0	1	0	0
&	06	6	0	1	1	0	0
'	07	7	1	1	1	0	0
(08	8	0	0	0	1	0
)	09	9	1	0	0	1	0
*	0A	10	0	1	0	1	0
+	0B	11	1	1	0	1	0
,	0C	12	0	0	1	1	0
-	0D	13	1	0	1	1	0
.	0E	14	0	1	1	1	0
/	0F	15	1	1	1	1	0
0	10	16	0	0	0	0	1
1	11	17	1	0	0	0	1
2	12	18	0	1	0	0	1
3	13	19	1	1	0	0	1
4	14	20	0	0	1	0	1
5	15	21	1	0	1	0	1
6	16	22	0	1	1	0	1
7	17	23	1	1	1	0	1
8	18	24	0	0	0	1	1
9	19	25	1	0	0	1	1
:	1A	26	0	1	0	1	1
;	1B	27	1	1	0	1	1
<	1C	28	0	0	1	1	1
=	1D	29	1	0	1	1	1
>	1E	30	0	1	1	1	1

* - Factory Setting

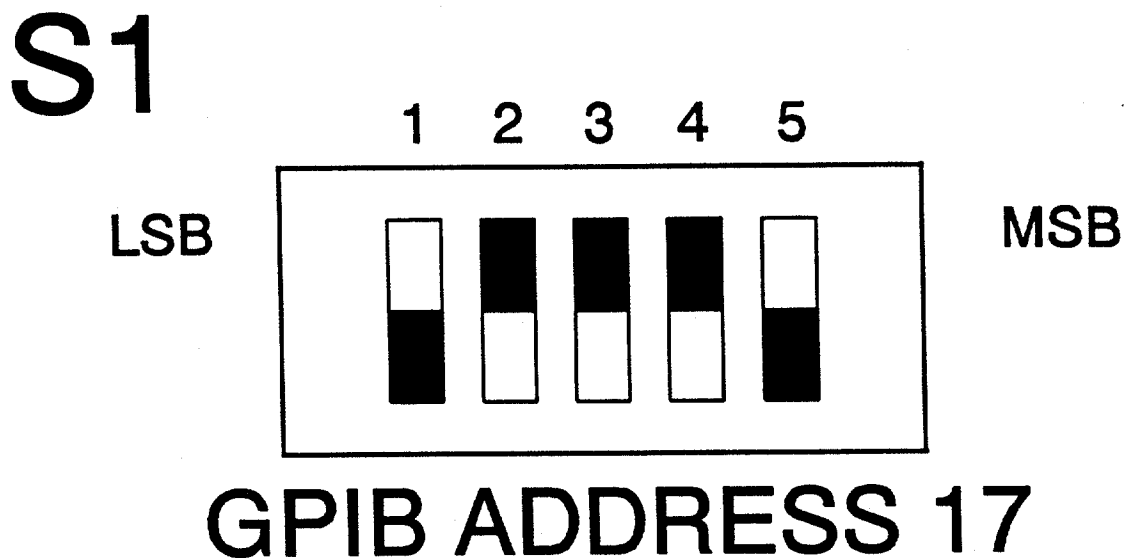

Figure 2-15. GPIB Address Switch (Rear Panel View)

2.5.5 Channel Group Select (Channel Group Select Switch)

Each chassis drawer contains six slots and, thus, up to six independent channels. Additional chassis drawers may be expanded onto the master chassis for additional slots of channels, as explained in paragraph 2.4, Configuration.

The Channel Group Select Switch (S2) permits slots of a given chassis drawer to be assigned different ranges of channel addresses. The master chassis processor supports up to 16 channels maximum.

The Channel Group Select Switch (S2) is located on the rear panel as seen in Figure 2-16. The switch position determines which of the three channel ranges are to be assigned to master modules contained within its respective

chassis drawer. More than one chassis drawer may share the same switch setting provided that master modules are not installed in identical slots as described in the Configuration topic. Slots 1 through 6 are left to right as viewed from the rear panel.

Channel Group Switch S2 assignments are:

Position A

A master module in the left-most slot becomes channel number 1 (rear panel view). Sequentially, counting slots to the right, each slot receives the next channel assignment. Slot 2 is assigned channel 2, slot 3 is assigned channel 3, etc. (if occupied by a master module). The right most slot is assigned channel 6 (if occupied by a master module).

Position B

Similar to Position A except channel assignment range is from channel 7 (slot 1 left-most) to channel 12 (slot 6 right-most).

Position C

Similar to Position A except channel assignment is from channel 13 (slot 1 - left-most) up to channel 16 (slot 4). The two right-most slots may not be used by master modules. They may remain empty or may be used as slave modules to one or more master modules located in the same chassis in slots 1 through 4.

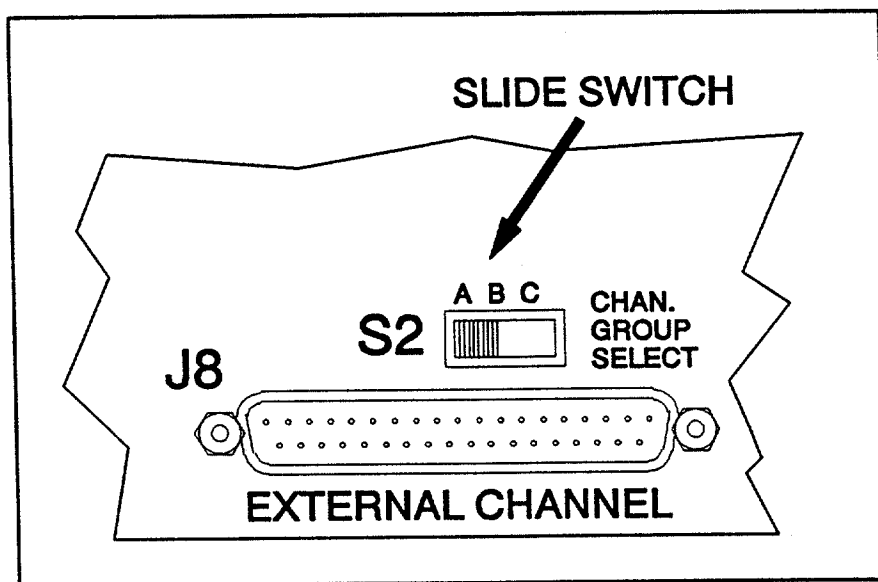

Figure 2-16. Channel Group Select Switch (Rear Panel View)

2.5.6 DFI/Shutdown

In the CIIL language version, both DFI (Direct Fault Indicator) and Shutdown are included on the same master chassis rear panel connector.

In the ABLE language version, Shutdown is an option; there is no DFI in ABLE.

The DFI output signal consists of a normally closed relay contact output. In normal (no run-time error) remote CIIL operation, the relay contacts are open circuit (relay actuated). The contacts

latch into the closed position to signal DC power fault conditions such as a loss of AC input power to the Model AT8000A. The DFI relay also latches in remote programming to signal power supply channel crowbar, current limit (CURL), or an over-temperature (TEMP) failure. Once activated (contacts closed), the DFI relay is reset upon receipt of the STA (status) command from the GPIB controller. The STA (status) command also initiates the Model AT8000A to send an error message via the GPIB.

Shutdown provides the Operator/ Programmer/Controller with the means to immediately reset the Model AT8000A without waiting for the GPIB. Shutdown uses the two pins with an internal isolated soft +5 volts. Momentarily closing the circuit across these two pins via an external relay contact or switch (only) immediately initiates the processor to open all channel relays and reset all setups to zeros (instrument reset routine).

CAUTION

DO NOT ATTEMPT TO GROUND EITHER OF THESE PINS, since this causes a ground loop which may be potentially destructive to the instrument Processor board.

DFI/Shutdown connector J9 (Amphenol 126-218), if installed, is located on the master chassis rear panel. The User supplied mating connector is Amphenol 126-217. The connector pin assignments are:

<u>Pin</u>	<u>Description</u>
A	DFI relay contact
B	DFI relay contact
C	--
D	Shutdown
E	Shutdown

2.5.7 External I/O Connector

The external I/O connector is used to input modulation signals for the Load modules as well as to output Sync signals. Table 2-2 provides a listing of these connections.

Table 2-2. External I/O Connector Pinout

J10					
Modulation Inputs			SYNC Output		
Channel	High Pin	Low Pin	Channel	High Pin	Low Pin
1	1	3	1	2	3
2	5	7	2	6	7
3	9	11	3	10	11
4	14	16	4	15	16
5	18	20	5	19	20
6	22	24	6	23	24

2.6 PROCESSOR BOARD JUMPER SETTINGS

2.6.1 W1 - CIIL/ABLE Language

The Processor board has a 64K EPROM containing the firmware for both the ABLE and CIIL languages. Jumper W1 on the Processor board, when installed, enables the CIIL software at power up. With W1 removed, the ABLE language will be enabled upon power up. After power up, the operator can move between CIIL and ABLE languages with the GAL and CIIL commands (refer to Section III).

2.6.2 W2 - Input to Emergency Shutdown

This is not a useable jumper. It should have the two wires from the DFI rear connector for the Emergency Shutdown Input.

2.6.3 W3 - Local Lock Out

When W3 is installed, the front panel keyboard cannot be used to change any of the programming status of the modules. It is similar to the remote mode where one can see the programming status and the load voltage and current, but cannot change any of the settings of the modules.

2.6.4 W4 - Troubleshooting Aid

W4 is used by Elgar's Manufacturing Test Department to aid in diagnostics of the Model AT8000A System.

- 1) If confidence test #4 fails, the display on the front panel will display the current measured reading.

- 2) Enables all current limit failure reporting features. Current limit failures are reported regardless of the programming status of the modules.

- 3) Enables all crowbar failure reporting even if the voltage is programmed to zero or if the current is programmed to zero or if the output relay is open.

2.6.5 W5 - Skip Confidence Test #4

W5 is used by a specific Elgar customer with a specially modified AT8000A System that prevents the Confidence Test #4 from being performed correctly. When W5 is installed and the Confidence Test is performed, the fourth test is skipped.

2.6.6 W6 through W11

The jumpers W6 through W11 are spare, unused jumpers that may be used at a future date.

2.7 AUXILIARY DRIVE MODULE INSTALLATION AND CONFIGURATION

There are three different ways the Auxiliary Drive Module (ADM) may have been supplied to the user:

#1 Configured and Calibrated for the External Supply

The ADM may be supplied as a system together with the external power supply that it is controlling. In this case, it has been configured and calibrated for that particular supply and, after being connected, it should be ready to be powered up and operated.

#2 Configured But Not Calibrated for the External Supply

The ADM may be supplied by itself and configured, but not calibrated, for the supply it will control. If, at the time of placing the order for the ADM card, Elgar Corporation is given the information on how the ADM is going to be used at the customer's site (make and model of the external supply), the ADM card will have been configured and calibrated, by itself, but not to the external supply. That is, the calibration of the ADM card does not correct for errors caused by the external supply. In this case, the customer should perform the final calibration on the ADM necessary for best performance.

#3 Unconfigured and Not Calibrated

The ADM may be supplied by itself, unconfigured and not calibrated. If, at the time of placing the order for the ADM card, Elgar Corporation is not given the information on how the ADM is going to be used, then it will be supplied unconfigured and not calibrated. In this case, the CUSTOMER MUST CONFIGURE THE ADM PRIOR TO POWER UP.

2.7.1 Installation

The ADM cards are installed into an AT8000A chassis just as a standard power module. The cards must be installed into a slot which has a 24-pin MS connector attached to it. To install the card, simply align the card with the connector toward the rear of the instrument, then place the module on the bottom of the card guide. While holding the module vertically, slide the module toward the rear chassis until the connector is fully engaged.

2.7.2 Configuration**NOTE**

Configuring an ADM card is well advanced of normal Operator or Programmer activities. After reading this section, if the configuration is beyond the user's normal capabilities, assign this task to a technician more familiar with making circuit adjustments and configurations.

2.7.3 Required Information From External Supply

The following is a list of information required to properly configure an ADM card for an external power supply:

- Manufacturer and Model of the Supply.*
- Output Full Scale Voltage.
- Output Full Scale Current.
- Full Scale Control Voltage Input.
- Full Scale Control Current Input.
- Load Current Signal.**
- Internal Connection of External Supply.***

* With the manufacturer and model number of the supply, most of the rest of the required information can be obtained from the supply's manual, with the exception of the load current signal.

** This is the signal supplied to the ADM that corresponds to the actual load current of the external supply. This may be the output of a current shunt, a current meter that outputs an analog signal, or a signal provided by the external supply.

*** This is the internal connection from input to output signals if any of the external supply. Some external supplies internally connect the negative of the input control for the voltage to the negative of the output voltage while other external supplies connect the negative of the input control voltage to the positive of the output voltage. This information is necessary for the proper configuration of the ADM.

This section should be used to configure an ADM card for a specific external power supply. It is used by Elgar's Test Technicians to first configure the ADM cards before connecting them to the external supply.

Required information (from the list above) must be obtained before the configuration can be performed.

2.7.4 ID PROM – U13

Before Turning Power On: Prior to configuring U13, the ID PROM, the maximum voltage and current values for the external power supply are required.

Perform the following:

1. Select the appropriate PROM and the corresponding jumpers from Table 2-3.
2. If the voltage and current values for the user's supply are not in the below table, then new values must be generated. Contact Elgar for assistance.
3. Install the correct ID PROM on U13 and the corresponding jumpers.

Table 2-3. ADM PROMS and Jumpers

Maximum Voltage	Maximum Current	Jumpers	Maximum Voltage	Maximum Current	Jumpers
PROM 1G			PROM 2A		
10	25	7	RELAY MODULE ONLY	----	7
10	50	6	LOAD MODULE ONLY	60 Volts & 60 Amps	6
10	99.99	5	60	4	5
20	25	4	6.25	0	4
20	50	8 & 7			
40	70	8 & 6			
40	98	8 & 5			
160	98	8 & 4			

2.7.5 Voltage DAC Section – R54 and Zero Offset

Perform the following:

1. Install jumper W10 to disable the over-voltage and over-current circuits.
2. Install the ADM into the AT8000A chassis and turn on the main power.
3. Place R48 at mid-range and R43 fully counter-clockwise.
4. Program the ADM to full scale voltage and measure the voltage at the top end of R41 or R63.
5. Adjust R54 until the measured voltage is exactly 4.8500 volts.
6. Program the ADM to zero volts and measure the voltage at the same point.
7. Adjust the Zero Offset pot until the output voltage is exactly zero.
8. Repeat full scale adjustment of steps 4 through 7 above until the following is measured:
 - a. 4.85 volts when full scale is programmed; and,
 - b. Zero volts when zero volts is programmed.

2.7.6 Low Voltage Control Output – R43 and R48

If the signal for the voltage control of the external supply needs to be greater than 10 volts, then skip this paragraph and proceed to the High Voltage Control Output, paragraph 2.7.7.

Perform the following:

1. Turn R18 fully counter-clockwise. This will turn off the high voltage output section which will not be used.
2. Program the AT8000A to full scale or to the most precise voltage value desired and measure the output voltage at VDAC pin C14.
3. Adjust R43 until the measured voltage is approximately equal to the full scale control voltage of the external supply.
4. Adjust R48 until the measured voltage is exactly equal to the full scale control voltage of the external supply.

NOTE

R43 and R48 are designed to adjust to a maximum of 10.2 volts. If a higher output is designed, R54 should be used. If, however, R54 is adjusted too far from its calibration setting, the ADM will fail the Internal Self Test (Confidence Test).

2.7.7 High Voltage Control Output – R18

If the signal for the voltage control of the external supply needs to be less than 10 volts, then skip this section and proceed to the next paragraph.

Perform the following:

1. Measure the voltage between the HIV output (P1B–C12) and VGND (TP2).
2. Program the ADM for full scale output voltage and adjust R18 until the voltage measured is exactly equal to the maximum voltage required for full scale output voltage on the external supply.

2.7.8 Current DAC Section – R53 and R71

Perform the following:

1. Place R57 at mid-range and R56 fully counter-clockwise.
2. Connect a voltmeter to TP10.
3. Program the ADM to full scale current and adjust R53 until the voltmeter reads exactly 4.8500 volts.
4. Program the ADM to zero current and adjust R71 until the voltmeter reads exactly zero volts.
5. Repeat steps 3 and 4 above until both the full scale and the zero current settings are accurate.

2.7.9 Current Control Section – R56 and R57

Perform the following:

1. Place R57 at mid-range and R56 fully counter-clockwise.
2. Connect a voltmeter to the IDAC signal (P1B-13) with respect to IGND (P1B-12 or TP1).
3. Program the AT8000A to full scale current and adjust R56 until the voltmeter reads approximately the full scale current control value.
4. Adjust R57 until the voltmeter reads the exact full scale current control value.

2.7.10 Voltage Sense – R10, R11, and R16

Perform the following:

1. Before configuring the voltage sense, determine, from the schematic diagrams of the external supply, the connection between the input control signals and the output voltage.
2. If the external supply connects the negative of the input voltage control to the negative of the output voltage or if the input signals are isolated from the output signals, then turn R16 fully counter-clockwise, R11 fully clockwise, and R10 to mid-range.

3. If the external supply connects the negative of the input voltage control to the positive output voltage, then turn R11 fully counter-clockwise, R16 fully clockwise, and R10 to mid-range.

This adjustment requires an externally generated voltage equal to the full scale output of the external supply. Use a bench top power supply, an AT8000A Power Module or the actual external power supply.

4. Apply the voltage to the VSENSE (P1A1-3,4) and VSENRTN (P1A1-5,6) inputs to the ADM card. Measure that voltage to ensure it is exactly equal to the full scale output of the external supply.
5. Place the AT8000A in the local measurement mode (2ND TST <2 digit channel number>) and adjust either R11 or R16 until the AT8000A front panel reads approximately the same as the voltage applied.
6. Adjust R10 until the voltage is exactly equal to the voltage applied.

2.7.11 Current Sense – R27, R66, and R70

This adjustment requires an externally generated voltage equal to the full scale load current signal of the external supply.

Perform the following:

1. Use a bench top power supply, an AT8000A power module, or the actual external power supply. Apply this voltage to the ISENSE (P1B-A14) and ISENRTN (P1B-A13) input to the ADM.

2. Place R66 at mid-range and R27 at the fully counter-clockwise position. Place the AT8000A in the local measurement mode [2ND TST (2 digit channel number)].
3. Adjust R27 until the front panel current reading is approximately equal to the full current of the external supply.
4. Short the input signal and adjust R70 until the front panel current reading is exactly equal to zero. Again, apply the external voltage to the current sense inputs and adjust R66 until the front panel current reading is exactly equal to the full scale current of the external supply.
5. Repeat steps 3 and 4 above until both the full scale and the zero scale are correct.

2.8 FUNCTIONAL VERIFICATION

This topic provides both incoming inspection and metrology lab personnel with a means of verifying correct Model AT8000A System configuration. This procedure should be performed upon initial receipt of the System and as a periodic check of the instrument. This procedure is not intended to check 100% of the instrument. Rather, it verifies the Model AT8000A fundamental performance parameters.

The following areas are verified:

Self Test: Operation of the controller board circuits and front panel display.

Confidence Test: Crowbar, current limit, test board calibration, and voltage accuracy.

Channel Configuration: Determines which channels are installed, corresponding voltage ranges, and other options.

Programmed and Measured Voltage: Voltage programming and voltage measurement are verified.

Current Limit Programming: Current limit programming is verified.

Remote Programming: Remote programming via the IEEE-488 bus is verified.

2.8.1 Test Equipment Requirements

Equivalent test equipment can be substituted if the exact model and manufacturer as listed in Table 2-4 below is not available.

Table 2-4. Test Equipment Requirements

Equipment Type	Manufacturer	Model Number
Oscilloscope	Tektronix	564
Controller (Or a computer which is GPIB compatible)	HP	HP-85
DC Voltmeter (0 to 320V range, 6 digit resolution, 0.01% accuracy)	Keithley	197A
DC Current Meter (0 to 60 Amps or less, depending on the maximum system requirements, 4 digit resolution, 0.01% accuracy)	----	----
DC Resistive Load (0 to 60 Amps or less in 0.25 Amp increments)	----	----

CAUTION

This instrument generates voltages hazardous to human safety. The user should already be familiar with the SAFETY notices on page ii.

To verify the configuration of this particular Model AT8000A, use the following verification procedure and the Configuration and Functional Verification Checksheet found in Appendix B. The Appendix B Checksheet can be photocopied and used to record test results of the user's Model AT8000A operation.

WARNING

This functional verification may routinely generate voltages hazardous to human safety. If the user are not already familiar with the attendant hazards and safe operating procedures involved, stop here and assign this task to a technician who is. This procedure and manual are not a tutorial on safety procedures for high voltage instrument maintenance and operation.

2.8.2 Logging System Data

Each AT8000A drawer may contain one to six plug-in DC modules of various voltages from 7 to 320 VDC and power levels from 105 to 1200 watts. One or more extender drawers may be interconnected to provide up to 16 channels of DC output.

The Checksheet in Appendix B contains space for logging data for one master drawer and six DC Modules (channels) which would be the simplest system configuration. Some of the spaces are for options which may not be installed in the user's specific system; these can be ignored.

Additional copies of the Checksheet can be attached for logging Extender drawer data.

2.8.3 Record Data on the Appendix B Checksheet

2.8.3.1 AC Input

Perform the following:

1. Check S3 on the rear panel for correct input AC voltage selection, either 115V or 230V. A flat blade screwdriver is required to change ranges.

CAUTION

DO NOT change voltage ranges while the unit is energized.

2. Record the selected range on checksheet (115 or 230).

2.8.3.2 Remote Programming Language

Perform the following:

1. Verify which programming language is installed, either ABLE or CIIL, by referring to the attached configuration card or packing slip.
2. Record this information on the Checksheet.

2.8.3.3 GPIB Address Select

Perform the following:

1. Select the Remote IEEE-488 GPIB address at S1 on the rear panel.
2. Record this information on the checksheet.

2.8.3.4 Group Select

The Group Select Switch, S2, allows the System to contain 6 channels of DC power in 3 different groups. If S2 is in the "A" position, channels 1-6 could be installed; in position "B", channels 7-12; and in position "C", channels 13-16. This switch will be set at the factory and should not be changed unless the system is being reconfigured. Record the Group position A, B, or C, on the Checksheet.

2.8.3.5 Local Control Keyboard/Display

The front panel keyboard allows local programming of voltage and other functions. The display will indicate programmed (or measured) or other information. Refer to Sections I and III for additional information. Record this information on the Checksheet.

2.8.3.6 Test

The Built In Test allows voltage, current, and other functions to be readback or monitored at the front panel display or over the IEEE-488 bus. Refer to Sections I and III for additional information. Record this information on the Checksheet.

2.8.3.7 Output Connections

Output connections can be either terminal strips or MIL-SPEC type connectors. Refer to Section 2.5 for interface pin definitions. Record the type of connections on the Checksheet.

2.8.3.8 DC Modules Installed

This section of the Checksheet has space for recording voltage and current, both programmed and measured, of each of the DC channels that are installed in a particular drawer. All programming will be from the local keyboard except for the remote tests in step 8j. Refer to Section III for programming and operating instructions.

NOTE

A channel can consist of one master module and one or more slave modules. It is important to identify where the master module is located in the System drawer.

The following is a list of information that can be recorded for up to six channels:

CNF Test: The Confidence Test is run by the microprocessor when power is applied to the drawer. If the battery backup option is installed, the CNF test must be initiated from the keyboard by pressing "2ND" and "CNF".

Channel Number: The channel number is identified by the internal microprocessor. To identify channel location, maximum voltage and current allowed on that channel, program Channel 1 "VOLT 9999". The front panel display will flash Channel 1 maximum voltage and maximum current (for

example, "40.00" and "5.00"). This data can be recorded on the Checksheet. Channels 2 through 6 can be identified in the same manner. If "00.00" flashes for voltage and current, this means that no module is installed in that slot or that channel slot contains a slave module.

Load Relay: The load relay test verifies that the output can be closed and opened. When it is closed, the display "CLS" LED will be on and voltage will be connected to the output. Record this information on the Checksheet.

Maximum Voltage: Maximum voltage for each DC Module as identified by the internal microprocessor. See "Channel Number" above. Record the maximum allowable voltage for each channel on the Checksheet.

Programmed Voltage: Voltage as programmed at the front panel keyboard. Program a voltage within the maximum range of each channel. For example: "15.00" on a 20 volt channel. Record this information on the Checksheet.

Measured Voltage: Voltage as measured on the rear panel of the System. Measure the programmed voltage from "Maximum Voltage" above (the voltage can be measured at the display if the System has the Test Option installed).

Programmed Current: Programmed current can be either Current Limit or Constant Current mode. For this test, a current limit is set within the current range of a channel as identified in "Channel Number" above. Record the programmed current on the Checksheet.

Measured Current: Apply a resistive load to the rear panel terminals. Measure the output DC current at the rear panel for each channel loaded (the current can be measured at the display if the Test Option is installed). Increase the current by decreasing the load resistance until the current limit is exceeded. Record this information on the Checksheet.

Polarity Relay: The polarity relay option test verifies that the polarity of the output voltage can be reversed. Verify that each channel polarity relay is operational. Record this information on the Checksheet.

Remote Tests: The remote test performed here can consist of all of the tests performed in the previous steps or be as simple as the user desires. The CNF command will verify that the System will respond to the IEEE-488 controller. Refer to Section III for remote programming information.

NOTES

SECTION III

OPERATION

3.1 INTRODUCTION

The Model AT8000A System controls and display are straightforward and readily understood after just a brief overview. Similarly, remote programming via both ABLE (Atlas Based Language Extension) and CIIL (Control Interface Intermediate Language) ATE languages is quick and simple since the Model AT8000A processor transparently takes care of the burdens of protocol, parsing, message format, error checks, and talker response messages back to the host ATE controller.

If the user is unsure as to their particular configuration, simply keystroke what the user desires to accomplish. The Model AT8000A either implements the user's commands or informatively identifies that particular channel's capabilities. Any additive effects of master/slaves is automatically included onto the display.

The internal processor continuously verifies the user's keyboard entries. Should an entry be inadvertently out of range for a particular channel setup condition, the processor immediately flashes onto the display the maximum permissible voltage and/or current available.

The Model AT8000A does not accept any self-destructive setup. However, care must be taken since the wide range output of this instrument can readily generate high voltages at sufficient current to cause great harm to personnel and equipment loads.

Operation of the Model AT8000A is organized into the following topics:

- 3.2 Power On/Off Sequence
- 3.3 Local/Remote Programming Overview
- 3.4 Local Programming (Keyboard/Display)
- 3.5 Remote Programming in ABLE
- 3.6 Remote Programming In CIIL
- 3.7 IEEE Definitions

WARNING

VOLTAGES HAZARDOUS TO HUMAN SAFETY may be routinely generated at the output terminals. Be familiar with the SAFETY notices on page ii. Use great care when any load is connected to the output of this instrument. The user MUST notify any operator or technician via WARNING signs or labels as to the possible hazards of voltage and current.

3.2 POWER ON/OFF SEQUENCE

Perform the following:

1. Verify the proper Installation of the user's Model AT8000A, including AC line voltage switch, any chassis drawer interconnects, and output/sense connections.
2. Switch Power to ON for all Model AT8000A extender chassis drawers (the master chassis is powered on last). It is also normal to switch AC POWER ON to the user's entire system from a central circuit breaker.

3. Immediately upon power on of the master chassis, the master chassis processor performs housekeeping on itself and the rest of the system. An initial one-time scan during this housekeeping identifies and records all installed channels, regardless of their chassis drawer(s). If an extender chassis drawer Power On is late or its AC power is removed at any time, the processor reports those channels as faulty.
4. If battery backup is not installed, the processor resets all output power modules to open circuit, clears all programming information, and initializes the GPIB interface. Next, the processor initiates the Confidence Test on all installed channels and then performs an instrument reset. Subsequently, the processor continuously performs internal housekeeping and scans for keyboard and remote programming inputs.
5. The battery backup option retains all channel setup (local and remote programming) information while AC power is OFF and restores these setups after a modified reset process. The Confidence Test is not run since all channel setups would be reset. All output relays are open to avoid any surprise to application loads (e.g., ATE application where a remote main circuit breaker powers up the entire test station at once).

The output relays only await an Execute 2ND EXC) keystroke to connect to the application load.

6. To Power OFF, good practice encourages disconnecting module outputs prior to removing AC power. Conveniently, the Confidence Test (2ND CNF or remote programming equivalent) automatically performs this task on all module outputs. This virtually eliminates unpredictable power down output glitches.

3.3 LOCAL/REMOTE PROGRAMMING OVERVIEW

The Model AT8000A System, whether used in local or remote (GPIB) programming, is factory configured for ABLE (Atlas Based Language Extension) and CIIL (Control Interface Intermediate Language). The processor contains both languages. A jumper located on the processor board determines the default language upon power up, as follows:

W1 Installed = CIIL
W1 Not Installed = ABLE

After power up, the user can move between language versions using the CIIL and GAL commands. Front panel operation is identical for either language version. However, the manner of remote programming and of channel operation differs slightly for these two language versions.

The keyboard EXC (execute) and the GPIB programming line terminator are equivalent activate codes for the Model AT8000A processor. Whether via a keyboard setup or GPIB programming string, all channel(s) setup programming are activated simultaneously. Should output isolation or polarity relays require a change of state, the processor automatically first turns off (voltage and current to zero) the particular channel(s).

Relays are then switched and, after a 30 ms delay, all module voltages and currents are re-programmed simultaneously to their previous levels. This automatic sequence eliminates hot relay switching and possible voltage spikes due to contact bounce as seen by the load.

In the ABLE language version, all channels are independent. Should a run-time fault on one channel occur, the other channels are not affected unless specifically programmed via the GRP (Group) command. GRP is not available from the keyboard. GRP is valuable when multiple DC power channel sets (or groups) are required for the user's application and all the DC power supply channels shut down in the event of a fault on any one supply in the set.

Remote programming faults for either language configuration are signaled to the controller via GPIB talk messages from the Model AT8000A processor. The front panel display also alerts the operator to any faults regardless of origin (keyboard, GPIB, or run-time).

Keyboard operation, ABLE and CILL languages, and their respective fault handling are separated in the following topics. The flashing front panel display is always available for any faults.

Syntax Notation used in this section is as follows:

Capital letters are required for remote command words and front panel keys.

[] Square brackets indicate optional programming. Text within square brackets is not required.

< > Angle brackets contain text which defines what it should be replaced by.

| Vertical bars separate multiple choices of entries available. At least one of the entries must be chosen unless the entries are also enclosed within square brackets.

... Ellipses indicate an entry may be repeated as needed.

3.4 LOCAL PROGRAMMING (KEYBOARD/DISPLAY)

For local control, only one keyboard/display is required on the Model AT8000A, regardless of the number of extender chassis drawers installed. The keyboard/display is an option and is not required for remote (GPIB) operation. The keyboard/display provides the operator with local capability for:

- Programming setup for each channel.
- Initiating self checks and channel monitoring.

- Display of programming and measured channel output activity.
- Alerting the operator as to error conditions.

3.4.1 Display (LED Status Indicators)

Figure 3–1 identifies the key areas of the display. The Front panel LEDs have the following functions:

RMT: Indicates the AT8000A system is in the GPIB remote control state. In the remote state, only the RTN and TST keys will function to show the programming status or to measure the input values respectively. The Force-Local-Control function uses the 2ND–4–1 key sequence (previous AT8000 models used the 2ND–9–1 key sequence for the same function).

TST: Indicates the AT8000A is in the measurement mode reading the input (or sense point if external sense is programmed) voltage and current. When used, this LED will flash. A measurement reading is taken every time it turns on or off. The voltage and current displays will show the measured readings.

CURR: Indicates that the channel shown in the channel display is in the Constant Current Mode or about to be placed in the Constant Current Mode.

When the PULSE LED and the CURR LED are both illuminated, this indicates that the module is in the Current Pulse Mode.

When the ENT LED is illuminated, this indicates the information may only be Entered but not executed.

RES: Indicates the channel shown in the channel display is in the Constant Resistance Mode, the Resistance Pulse Mode, or is about to be placed in the Constant Resistance Mode.

When the PULSE LED and the RES LED are both illuminated, this indicates the module is in the Resistance Pulse Mode.

When the ENT LED is illuminated, this indicates the information may only be Entered but not executed.

PULSE: Indicates that the channel in the Channel display is in the Pulse Mode (Transient Generator) or about to be placed in the Pulse Mode (Electronic Load modules only).

When the PULSE LED and the CURR LED are both illuminated, this indicates that the module is in the Current Pulse Mode.

When the PULSE LED and the RES LED are both illuminated, this indicates the module is in the Resistance Pulse Mode.

When the PULSE LED is illuminated without either the CURR or the RES LEDs, this indicates the module is in the Voltage Pulse Mode.

When the ENT LED is illuminated, this indicates the information may only be Entered but not executed.

SHORT: Indicates that the channel shown in the Channel display is in the Short Circuit Mode or is about to be placed in the Short Circuit Mode.

ENT: Indicates that the values seen on the front panel have been entered, but not executed. In this mode, values are temporarily stored internally until the 2ND-EXC sequence is received. In this way, multiple channels can be executed simultaneously.

CLS: Indicates that the channel shown in the Channel display is programmed with the input Isolation (disconnect) relay closed (connected) or is about to be programmed with the Isolation relay closed.

POL: With the DC Power Modules, indicates that the output power is of reversed polarity. Not used with the Electronic Load modules since they do not have the option of receiving DC power of reversed polarity.

SENS: Indicates that the channel shown in the Channel display is programmed for external (remote) sense or is about to be programmed for external sense.

CROWBAR / OVER VOLT: Indicates that the channel shown in the Channel display detected an over-voltage condition and was shut down (programmed to zero and isolation relay opened). Only the DC Power Modules have a Crowbar at their output.

TEMP / OVER POWER: Indicates that the channel shown in the Channel display detected an over-temperature or an over-power condition. As a result, the channel was programmed to zero and its isolation relay was opened.

CURRENT LIMIT: Indicates that the channel shown in the Channel display detected an input current that was higher than the programmed current limit value (not used on Electronic Load modules). As a result, the channel was programmed to zero and its input isolation (disconnect) relay was opened.

3.4.2 Keyboard Functions

The front panel keyboard implements the familiar calculator-like keypad arrangement of numbers and multi-function keys. The upper half functions are keyed directly, while the lower half functions are immediately preceded by depressing the 2ND key momentarily. For example, an Execute is implemented in two keystrokes by depressing the following sequence 2ND EXC. Figure 3-2 identifies the keyboard functions.

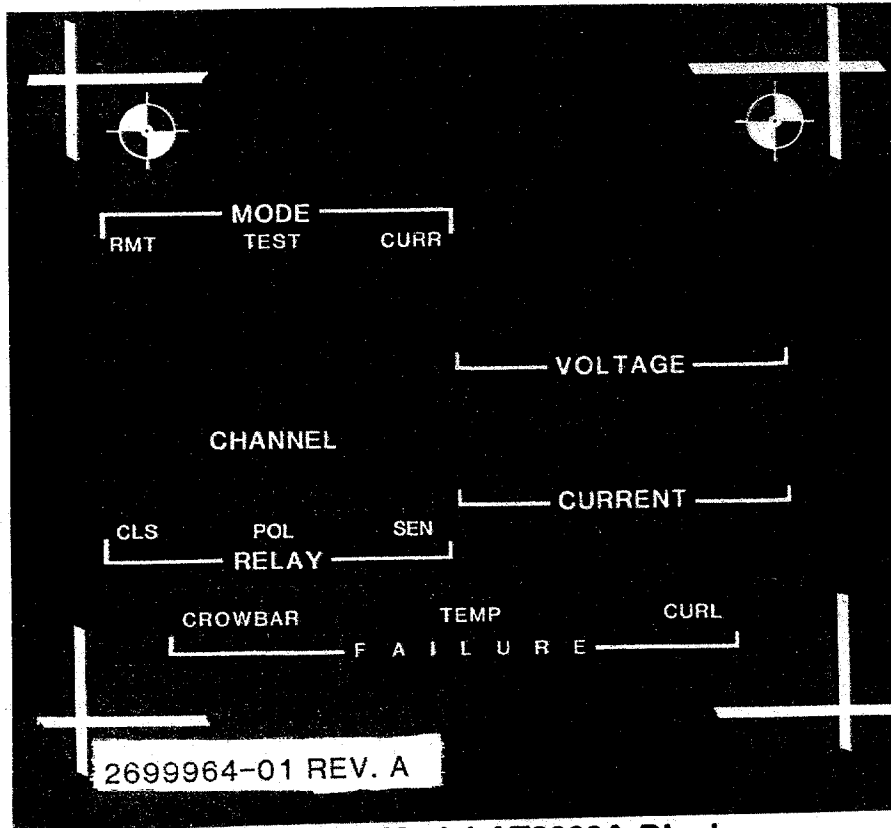

Figure 3-1. Model AT8000A Display

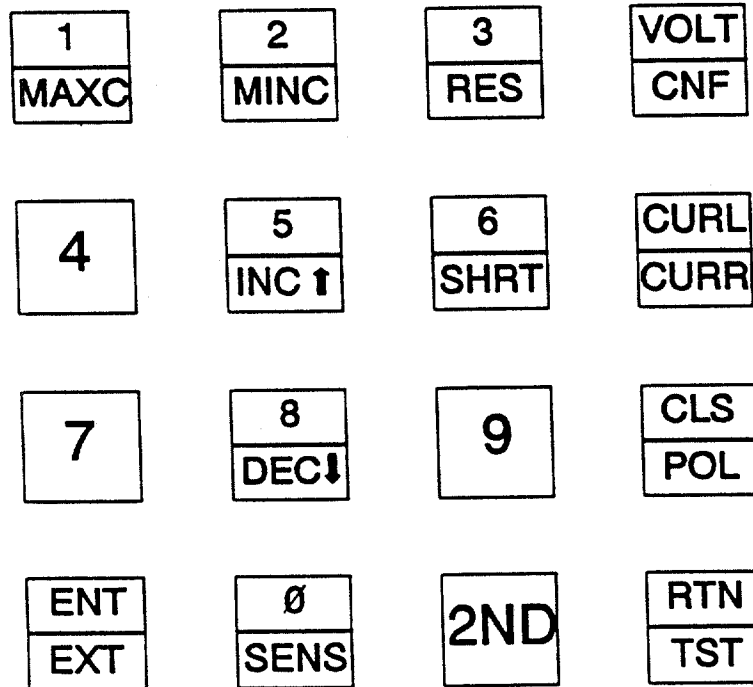

Figure 3-2. Model AT8000A Keyboard Functions

To avoid keyboard entries from inadvertently changing remote programming setups, the Remote Mode LED signals a lockout of keyboard edits. The Remote LED is not illuminated upon Power ON reset and is activated by the controller addressing the instrument via the GPIB to receive channel setups or instrument System processor commands such as CNF, RTN, PAR, etc.

Full keyboard control is regained by the keyboard entry of 2ND 911. This keystroke sequence is known as keyboard Go To Local (GTL) and is only available in ABLE version (not available in the CIIL version). Keyboard GTL is disabled (not available from the keyboard) only if the controller has already sent a GPIB LLO (Local Lockout Command). Momentarily removing the GPIB cable or by the remote controller sending the GPIB GTL command also clears the Remote LED (and cancels any LLO command). The keyboard Return and Test functions select and monitor channels only (no edit), and thus are never locked out.

The keyboard provides local operator control to reset, program, and verify operation of the instrument. These capabilities are broken into two categories – immediate execute and multiple setups for simultaneous execution.

The immediate execution keyboard functions do not use ENT or EXE. Except for CNF, these do not affect channel programming nor output. The immediate execute functions are: GTL, CNF, TST, and RTN.

3.4.2.1 GTL (Keyboard Go To Local) (Keyboard Programming)

Syntax:

2ND 41

Examples:

2ND 41

Remote LED goes dark. Full keyboard control.

2ND 41

No effect since the controller had sent LLO already.

Normally, the front panel keyboard is disabled from editing any channel setups once the instrument Remote LED is illuminated. The RMT LED is illuminated upon receipt of any GPIB programming strings. The GTL front panel entry clears the RMT LED. The front panel GTL is identically implemented as the GPIB GTL command.

Keyboard GTL is disabled if a GPIB LLO (Local Lockout) command has been sent by the controller to the instrument (most system programmers prefer not to use GPIB LLO). This give the freedom of keyboard GTL availability should any front panel manipulation of the instrument be desired. The GPIB LLO is specifically to prevent such front panel manipulation.

Keyboard GTL is available in the ABLE version; it is not available in the CIIL version.

3.4.2.2 CNF (Confidence Test) (Keyboard Programming)

Syntax:

2ND CNF

Example:

2ND CNF

Initiates the Confidence Test and the display goes to CHANNEL 01.

The Confidence Test opens all output isolation relay(s), performs internal calibration and diagnostics, and then reprograms all channels to zero. This is the quickest way to reset all channels. The defaults are:

- Channel 01
- Mode and relay LEDs all dark.
- Voltage zero and Current Limit Mode (CURL) of zero.

For more information on the Confidence tests, see CNF under section 3.5, Remote Programming In ABLE.

3.4.2.3 TST (Test) (Keyboard Programming)

Syntax:

2ND TST<2 digit channel number 00 to 16>

Examples:

2ND TST 01
Monitor Channel 1.

2ND TST 06 Monitor Channel 6.

Test is a real time monitoring on the display of actual load current and sense lead voltage for the selected channel, thus testing the channel output. TST automatically displays the selected channel and thereby no RTN selection is required.

The Test display LED alternates on and off as each new voltage and current value is measured and displayed. This keyboard function is also available while the Remote LED is illuminated. TST requires the Test board option. TST is canceled automatically upon any keystroke.

Should the Test display indicate very low current (approximately zero), be suspicious that the channel output isolation relay is not connected (CLS not illuminated). If the channel output isolation relay is not closed (no load), then an internal load resistor simulates approximately a 2% full load and is monitored accordingly on the display.

The Test display may read either very low or improperly low values for voltage and current if the programmed voltage and or current (CURL or CURR) is very low or zero. In some cases, when the CURL limit is set too low, the DC Power Module may go into current limit and illuminate the CURL FAILURE LED.

3.4.2.4 RTN (Return)
(Keyboard Programming)

Syntax:

RTN<2 digit channel number 00 to 16>

Examples:

RTN 02
The display is setup for Channel 2.

RTN 03
The display is setup for Channel 3.

RTN selects a new channel. This is the function used for selecting a new channel for program review and edit. All previously entered programming setup for that channel is displayed (as fetched from a 16 channel wide buffer). This enables the operator to review or modify the setup. This keyboard function is available while the Remote LED is illuminated (local edit of the setting is still locked out).

3.4.2.5 Software Parallel
(Keyboard Programming)

Syntax:

2ND-4-5 <2 digit master channel number> <2 digit slave channel number> <2 digit slave number>...ENT

Example:

To parallel channels 1, 5, 9, 12, and 16 and to select channel 9 as the master channel, the entry sequence would be:

2ND 4 5
Sets up the parallel entry mode.

0 9

Selects Channel 9 as the master channel; the master channel is always entered first.

0 1

Selects the slave channels.

1 2

Slave channel sequence is arbitrary.

0 5

1 6 ENT

Once the modules are paralleled, the module designated as the master assumes the power capability of parallel combination and the slave modules will behave as if they were not installed. In the above example, if the five modules were 20 volt/10 ampere modules, then Channel 9 would become a 20 volt/50 ampere module and all other channels could not be programmed. The microprocessor takes care of proportionately dividing the voltage and current between the master and slaves.

In the above example, after pressing 2ND 4 5, the display will show 45 in the channel number, the voltage display will show "P-bb" for Parallel function and the current display will show "b-bb" where "b" signifies a blank character.

The first channel number entered will show on the right two digits of the current display. The following channel numbers will, in turn, scroll from the current to the voltage display. When resuming with the ENT key, the display should continue showing its present contents.

If the display clears itself during the entry process or after ENT is pressed, it means an error was made in the entry process.

To cancel or reset the Parallel function from the front panel, use the 2ND 4 9 Reset Sequence command described later in this section.

The paralleled channels are automatically grouped together; if a failure occurs on one of the channels, it will behave as a failure on all channels to the paralleled set. Consequently, all channels would be reset to the quiescent state simultaneously. Only modules of the same voltage rating can be paralleled together.

3.2.4.6 Group Function (Keyboard Programming)

Syntax:

2ND 4 6 <2 digit channel number> <2 digit channel number>...ENT

Example:

To group channels 1, 5, 9, 12, and 16 together, the entry sequence would be:

2ND 4 6

Sets up the group entry mode.

0 9

Selects the channels to be grouped.

0 1

Channel sequence is arbitrary.

1 2

0 5

1 6

ENT

Channels may be grouped together to run independent tests on different boards, where each group is never affected by failures or events occurring on other groups. If, however, one channel in the group fails, then all channels in that group will be reset.

In the above example, after pressing 2ND 4 6 to place the front panel in the group entry mode, the voltage display will show "G-bb" for group function and the current display will show "b-bb" where "b" signifies a blank character.

The first channel number entered will show on the right two digits of the current display. The following channel numbers entered will in turn show on the current display and the previous channel will scroll from the current to the voltage display. When resuming with the ENT key, the display should continue showing its present contents.

If the display clears itself during the entry process or after the ENT key is pressed, it means that an error was made in the entry process.

To cancel or reset the group function from the front panel, use the 2ND 4 9 Reset sequence discussed in the next paragraph.

3.2.4.7 System Reset (Keyboard Programming)

Syntax:

2ND 4 9

This command sequence programs all installed channels to zero volts and zero current, opens all relays, and cancels all previous group and parallel commands. It places the AT8000A at the power up quiescent condition.

The main use for this command is to cancel or reset all previous Parallel and Group commands.

3.4.2.8 Display Firmware Version Number (Keyboard Programming)

Syntax:

2ND 7 6

This key sequence will display the version of the installed firmware on the voltage display. During this time, the channel number display will show "76" to indicate that the front panel is not in the normal display mode.

3.4.2.9 Display GPIB Address (Keyboard Programming)

Syntax:

2ND 7 7

This key sequence displays the GPIB address on the front panel voltage display. During this time, the channel number display will show "77" to indicate that the front panel is not in normal display mode. The address displayed is

that which was in place during power up. It is not necessarily the present address (since the address could have been modified since power up). The switch address is read by the processor only one time during this power up sequence.

For output load safety and maximum flexibility, it is highly desirable not to have the channel outputs responding to every keystroke entry immediately. The Model AT8000A processor instead allows the user to select a channel, program it, check for errors, enter the setup into a 16 channel wide buffer, repeat this process on the same or another channel, and then finally execute a simultaneous output on all channels. No intermediate aberrations are ever seen by the application load.

The internal processor already knows details of itself and installed channels (e.g., voltage ranges, current range, relays, BIT, etc.). It does not permit any faulty or out of performance conditions to harm itself or reach the output terminals.

Two keyboard functions implement this buffering and simultaneous implementation of the setup parameters on each channel – ENT and EXC.

3.4.2.10 ENT (Enter) (Keyboard Programming)

Syntax:

ENT

Examples:

ENT

Everything on this channel is entered.

VOLT 1234 ENT

The Voltage is updated and entered.

VOLT 1234 CURL 0123 2ND POL CLS ENT

The entire setup is entered.

VOLT 1234 ENT CURL 0012 ENT

Too many ENTs, but no error.

ENT accepts the channel setup information (voltage, current limit, output isolation relay, etc.) keystroked onto the display and shifts the channel setup into a buffer for later execution. Any errors within the ENT setup result in a flashing display and the errors are thrown away without being executed.

If an excessive value of VOLT, CURR, or CURL is entered, regardless of the validity of the rest of the channel setup, the processor does not accept the ENT immediately. Instead, the display informatively flashes the maximum permitted value. The next keystroke (any, including ENT) cancels the flashing and restores the last valid channel values to aid proper keyboard programming. This process may be repeated as often as necessary. Persistent errors are displayed after EXC (Execute). The Model AT8000A does not program any channel with a faulty setup.

Use the ENT key once upon finishing all keyboard edits on a given channel. It is redundant and a waste of keystrokes to ENT every individual function. The user must use ENT to save the user's channel edits before EXC, select monitor (Test), or select another channel (Return). These three functions and remote programming cancel all non-ENT keyboard edits.

3.4.2.11 **EXC (Execute)** (Keyboard Programming)

Syntax:

2ND EXC

Example:

2ND EXC

All channel setups are simultaneously actuated.

RTN 03 VOLT 0500 2ND EXC
OOPS, forgot to ENT before EXC.

VOLT 0500 ENT 2ND EXC

The Voltage is updated and all are actuated.

EXC actuates all valid programmed data previously entered for all installed channels simultaneously. EXC is not channel dependent. If a channel setup is not entered, its previously entered value is used.

EXC actuates all the channel setups simultaneously. It is redundant to EXC each channel one at a time unless the user specifically wishes to actuate them sequentially.

The following DC power supply channel setup parameters apply to each of the installed channels and are edited via the keyboard. The processor already knows each channel's capabilities and the options installed.

As indicated above, a flashing Voltage and or Current display indicates an out of range entry, but the maximum value is being flashed only for the user's information.

If an option is not installed (e.g. Polarity relay) its parameter is ignored and the corresponding display LED remains dark.

If the user is about to edit several setup parameters on a given channel, there is no need to repeat the ENT key after each parameter. Instead, wait until the channel setup is complete to save those redundant keystrokes.

The following parameters apply to each of the installed channels. The normal local programming sequence is:

1. Select a channel via RTN.
2. Enter the function and value (if required).
3. Repeat step 2 for the entire channel setup.
4. Press ENT.
5. Select another channel as per step 1 and repeat this process.
6. Press 2ND EXC upon completion.

The syntax for keyboard entries requires two digits for the channel (via RTN) entry ranging from 01 through 16. VOLT, CURR, and CURL require a four digit entry. The numeric range of the four digit entries and corresponding decimal point is determined by the processor, desired current mode (CURL or CURR) and the DC Power Modules installed.

3.4.2.12 VOLT (Voltage) (Keyboard Programming)

Syntax:

VOLT <number keys> [ENT]

Examples:

VOLT 0555

5.55 VDC is programmed but not yet entered.

VOLT 0555

55.5 VDC is programmed on a 100 volt module but not yet entered.

VOLT 1234 ENT

The Voltage is programmed and entered.

RTN 03 VOLT 2345 ENT

A new Voltage is entered on Channel 03.

VOLT selects the channel voltage. If accompanied by CURL, the channel maintains this constant programmed voltage on its output. If accompanied by CURR, the channel voltage varies from zero volts up to this maximum voltage to maintain constant current (CURR) value. The default voltage is whatever appears on the display in when local control (in remote, the default is the maximum voltage capability of the module).

3.4.2.13 CURR (Constant Current) (Keyboard Programming)

Syntax:

2ND CURR <number keys> [ENT]

Examples:

2ND CURR 0500 ENT 2ND EXC

5.00 amperes in the CURR mode at the previously setup compliance voltage.

2ND CURR 1500 Volt 0700 ENT 2ND EXC

The Constant Current Mode at 15.00 amperes with a compliance voltage of 7.00 VDC.

2ND CURR 9999 VOLT 2800 ENT
OOPS, the flashing display signals the maximum current available in the CURR mode on this channel at this compliance voltage.

CURR activates the Constant Current (CURR) Mode LED on the display and sets the constant current value in amperes. CURR should be accompanied by the VOLT entry. Voltage varies (0V to maximum) to maintain this constant current.

If the setup voltage value is zero and the instrument is in local (keyboard) control, then the CURR mode compliance voltage is zero and very little current is available in CURR mode (an impractical setup). If in remote, the compliance voltage default significantly differs (refer to section 3.5, Remote Programming in ABLE for additional information).

3.4.2.14 CURL (Current Limit) (Keyboard Programming)

Syntax:

CURL <number keys> [ENT]

Examples:

CURL 0345 ENT 2ND EXC
Current limit of 3.45 amperes.

VOLT 0500 CURL 0200 ENT
5 volts at 2 amperes maximum.

CURL 0000 ENT 2ND EXC
Probable fault since the current is set so low.

Activates current limit (CURL) mode and sets load current fault limit in amperes. Voltage remains constant in CURL.

Upon load current reaching this value, the Failure current limit (CURL) LED is illuminated and the channel output shuts down including opening the output isolation relays.

Use care with CURL setup at or near zero current since even the internal load resistor draws some current. Thus a zero CURL setup value may easily, and properly, cause a CURL failure.

3.4.2.15 CLS (Close) (Keyboard Programming)

Syntax:

CLS [ENT]

Examples:

CLS
The CLS LED changes state, but not entered.

CLS CLS
The (CLS LED momentarily changes, then returns to the original state.

RTN 07 CLS ENT 2ND EXC
The Channel 7 output isolation relay is toggled to the opposite state (i.e., closed if originally open or open if originally closed).

CLS will either close or open the output isolation relay. CLS is an alternate action keyboard function key (just press CLS again to change the setup state). If closed, the relay LED is illuminated, then the setup is for closed output isolation relay contacts to the external load. Press CLS again for the closed relay LED to not be illuminated to setup for no channel output power to the load.

3.4.2.16 SENS (Sense) (Keyboard Programming)

Syntax:

2ND SENS [ENT]

Examples:

2ND SENS

The Sense relay LED changes state.

2ND SENS ENT

The Sense relay LED changes state and is entered.

2ND SENS ENT 2ND EXC

The Sense relay LED changed, entered, and the Sense relay is actuated to the LED indicated position.

SENS controls the internal sense relay to sample the output voltage, either internally or via external sense leads (user supplied which connect to the user's load). SENS is an alternate action function key. If the sense relay LED is illuminated, then the setup is for the sense relay to switch to the remote (external) sense lead pickup. Press SENS again for the sense relay LED not being illuminated and for internal sense voltage.

When sensing internally, the sense point is before the output relays and the load regulation is approximately 20 mV per ampere. The actual relay switching occurs simultaneously with the output isolation relay.

3.4.2.17 POL (Polarity) (Keyboard Programming)

Syntax:

2ND POL [ENT]

Examples:

2ND POL

The Polarity LED changes state on the display.

2ND POL VOLT 1234 ENT 2ND EXC

If the POL LED is now illuminated, then negative (-) 12.34 VDC is actuated. If the POL LED is not illuminated, then +12.34 VDC is actuated.

POL controls the polarity relay to internally reverse both the output and the sense leads. POL is an alternate action function key. If the POL RELAY LED is illuminated, then the setup is for a negative voltage on the terminals. Press POL again for normal polarity at the output terminals (POL RELAY LED not illuminated). For simplicity, treat the POL RELAY as a negative sign for the voltage display. The actual relay switching occurs simultaneously with the output isolation relay.

3.4.3 Local Programming Examples (Keyboard Programming)

Table 3-1 provides a listing of local programming examples.

Table 3-1. Local Programming Examples

Keys Pressed	Description
2ND CNF	Opens all output relays, performs Confidence Test on all installed channels, and resets all channels to zero.
RTN 05	Displays last entered program values of Channel 5.
VOLT 4458	Programs voltage to 44.58 volts.
2ND CURR 0245	Programs Constant Current mode (CURR LED illuminated) to 2.45 amperes.
2ND POL CLS ENT	Programs polarity and output isolation relays and stores setup for Channel 5.
RTN 02	Displays the last entered values of Channel 2.
VOLT 2330	Programs voltage to 23.30 volts.
CURL 0457	Programs Current Limit mode (CURR LED not illuminated) to 4.57 amperes.
CLS 2ND SENS ENT	Programs output isolation and remote sense relays and stores setup for Channel 2 (Channel 2 was last used above).
2ND EXC	Actuates all relays and energizes all entered channels.
2ND TST 05	Displays the load voltage and current for Channel 5. TEST LED is blinking.

3.4.4 Electronic Load Module Programming Using The Front Panel

The following local programming commands apply only to the Electronic Load module.

NOTE

The input isolation relay needs to be closed before the Electronic Load will operate in any mode. Check the CLS command discussed in paragraph 3.4.2.15 above.

All programming examples in this topic apply to Electronic Load modules with a full scale voltage capability of less than 100 volts. The voltage and resistance decimal point for a module of less than

100 volts is on the second digit (out of 4 digits total) as opposed to on the third digit for modules of 100 volts and higher. These same examples can be used on either module types if the user takes into account the difference in the decimal place position.

3.4.4.1 INCrement and DECrement Keys (Load Module Keyboard Programming)

The Model AT8000A allows the incrementing and decrementing of any values displayed on the front panel.

To use the INC/DEC keys, first program the desired mode of operation and levels as described in the following paragraphs. Then, to increment, again select the mode followed by 2ND INC.

Examples:

To increase current:

2ND CURR 2ND INC

Hold the key down while the values increase; after a few seconds the values will increase faster.

To decrease current:

DEC

Hold until the desired value is displayed.

By holding down the INC/DEC key, the least significant digit of the value will first scroll slowly, then scroll faster and finally it will scroll faster on the third digit from the left.

The user may switch from the INC key to the DEC key and vice versa without pressing any other keys until the desired value is reached. If another key is pressed, then the mode must again be entered followed by the 2ND INC/DEC keys.

3.4.4.2 Constant Current Mode (Load Module Keyboard Programming)

Syntax:

2ND CURR <number keys> ENT 2ND EXC

Example:

RTN 03 2ND CURR 500 CLS ENT 2ND EXC

Programs the load in channel 3 to 5 amperes in the Constant Current Mode.

In the Constant Current Mode, the Load module will vary its conduction to maintain the current at the programmed value regardless of the input voltage. In this mode, the CURR LED will be illuminated (green).

NOTE

Once the CLS command has been entered to close the input isolation relay, it does not have to be repeated unless it has been opened since the last command entry. To open the load relay, use the keystrokes:

RTN 03 CLS ENT 2ND EXC

3.4.4.3 Constant Resistance Mode (Load Module Keyboard Programming)

Syntax:

2ND RES <number keys> ENT 2ND EXC

Example:

RTN 03 2ND RES 333 ENT 2ND EXC
Programs the load on channel 3 to the Constant Resistance Mode with a value of 3.33 Ω.

In the Constant Resistance Mode, the load module will sink a current that is linearly proportional to the applied voltage to simulate the value of resistance that has been programmed. In this mode, the RES LED will be illuminated (green).

3.4.4.4 Constant Voltage Mode – VOLT or CURL
(Load Module Keyboard Programming)

Syntax:

VOLT <number keys> CURL <number keys> ENT 2ND EXC

Example:

RTN 03 VOLT 1000 CURL 800 ENT 2ND EXC

Programs the load in channel 3 for a constant voltage of 10 volts at 8 amps maximum. This requires the power supply to be capable of over 10 volts, but less than 8 amps.

In the Constant Voltage Mode, the Electronic Load module will vary its current to maintain the voltage at the programmed value. By modulating the current, a constant voltage will be maintained.

A current limit protection value must be entered in this mode which will cause the module to shut down when the current reaches approximately 10% above the programmed limit value. If current limit protection is not required, simply enter the value of the maximum current rating of the module.

3.4.4.5 Current Pulse Mode
(Load Module Keyboard Programming)

Syntax:

2ND MAXC <number keys> 2ND MINC <number keys> ENT 2ND EXC

Example:

RTN 03 2ND CURR 2ND MAXC 800 2ND MINC 400 CLS ENT 2ND EXC

Programs the load on channel 3 to the Current Pulse Mode, with 8 amps maximum, 4 amps minimum, switching at 200 Hz, with a 50 % duty cycle 1.0 Amp/ μ s (the frequency and duty cycle automatically go to default values).

In the Current Pulse Mode, the Electronic Load module will vary the current between the maximum and minimum programmed current values (MAX and MIN, respectively). The frequency, duty cycle, and slew rate are not selectable from the front panel and will default to 200 Hz with a 50% duty cycle and 1.0 Amp/ μ s. In this mode, the load conduction will vary as needed to keep the current switching between the two programmed values.

3.4.4.6 Voltage Pulse Mode (Transient Generator)
(Load Module Keyboard Programming)

Syntax:

VOLT 2ND MAX <number keys> 2ND MIN <number keys> ENT 2ND EXC

Example:

RTN 03 VOLT 2ND MAX 1000 2ND MIN 0500 ENT 2ND EXC

Programs the load on channel 3 to the Voltage Pulse Mode, with 10 volts maximum, 5 volts minimum. This requires the power supply to be set to over 10 volts and current limited to a reasonable value.

In the Voltage Pulse Mode, the load module will vary the voltage between the maximum and minimum programmed values (MAX and MIN, respectively). The frequency, duty cycle and slew rate are not selectable from the front panel and will default to 200 Hz, 50% duty cycle and the maximum slew rate. In this mode, the load conduction will vary as needed to keep the voltage switching between the two programmed values.

The slew rates are dependent mostly on the speed of the power supply used.

**3.4.4.7 Resistance Pulse Mode
(Transient Generator)
(Load Module Keyboard Programming)**

Syntax:

**2ND RES 2ND MAX <number keys>
2ND MIN <number keys> ENT 2ND
EXC**

Example:

**RTN 03 2ND RES 2ND MAX 0500 2ND
MIN 0250 ENT 2ND EXC**

Programs channel 3 in the Resistance Pulse Mode to a maximum of 5 Ω and a minimum of 2.5 Ω .

In the Resistance Pulse Mode, the load module will vary the current and the voltage proportionally to each other in order to keep the effective resistances varying between the maximum and minimum programmed values (MAX and MIN, respectively). The frequency, duty cycle and slew rate are not programmable from the front panel and will default to 200 Hz, 50% duty cycle and the maximum slew rate. In this mode, the load conduction will vary as

needed to keep the effective resistance switching between the two programmed values.

When using larger currents, the Electronic Loads may not regulate resistances that are greater than a factor of 5 away from each other.

**3.4.4.8 Short Circuit Mode
(Load Module Keyboard Programming)**

Syntax:

2ND SHRT ENT 2ND EXC

Example:

2ND SHRT ENT 2ND EXC

Programs the load for a short condition.

In the Short Circuit Mode, the Electronic Load module will simulate a short circuit with a low value of resistance. To simulate a short circuit, the processor programs zero volts and full scale current in the load.

**3.4.4.9 Software Parallel Mode
(Load Module Keyboard Programming)**

Syntax:

2ND 4 5

As with the standard AT8000A power modules, the Electronic Load modules can be paralleled to achieve higher power and current capabilities. The modules must have the same ratings (same maximum voltage and same maximum current) to be paralleled. Modules also do not need to be in adjacent slots and do not need to be in

the same chassis to be paralleled. For more information on paralleling modules refer to the paralleling topic for standard DC power modules in Section 2, Installation.

3.4.4.10 Measuring The Load Current and Voltage (Load Module Keyboard Programming)

Syntax:

2ND TST <number keys>

Example:

2ND TST 03

Measure and display the channel 3 load current and voltage on the panel.

3.4.5 Flashing Error Codes

A flashing error code on the display signals the operator of a setup or other detected error within the instrument. The processor continuously scans for any detectable fault. Faults originate from the keyboard, channel power module fault flags, BIT (Built In Test) board, and GPIB interface. Certain faults may actually originate from outside the instrument (e.g., AC line voltage dropout, short circuit at load, or remote programming error). All keyboard and GPIB entries and virtually all other failures are detected before any permanent damage can occur to the instrument.

Run-time errors on ABLE language version instruments affect channels independently. That is, an error on one channel does not affect any other channel. The only exception is if the remote GRP (GROUP) command has

been used to specify a set or sets of channels which must simultaneously shut down in the event of any run-time failure of any channel within their set. The default is sixteen independent groups. CIIIL language version instruments always shut down all channels for any run-time error.

Pressing any key cancels the flashing error display, but not the cause of the error. If an error condition no longer exists, the display returns to normal. The flashing channel number typically indicates where to find additional FAILURE LED information.

Return the flashing channel number (RTN) to display more information on the failure. Once the cause of the failure is corrected, the channel may be returned to its previous state simply by pressing RTN<channel number>, ENT, and 2ND EXC (returning the channel).

3.4.5.1 Flashing Current Display

The current display flashes whenever the current being programmed is higher than the maximum current allowed for the programmed voltage. The processor already includes additive current effects of slave modules on the channel. The display flashes the maximum current allowed for the voltage programmed. Any keystroke returns the display to its last correct setup.

Most modules have a derating curve on the current when the voltages are less than 75% of full range voltage (7 and 10 volt modules are always 100%, no derating). Thus, maximum current is not always available for setup. Also, in the constant current mode (CURR), only 60% of full range current (7 and 10 volt

modules are 100%) is allowed for any voltage value. See the Output Current Range under Electrical Specifications in Section I.

3.4.5.2 Flashing Channel 01 - 16

A flashing channel number 01 through 16 signals the corresponding channel had either a Confidence Test failure or a run-time failure.

A Confidence Test failure is identified by a VOLTAGE display of "Ex" where "x" is the specific number (1 through 4) of the failed test.

A run-time failure has no "E" on the VOLTAGE display. The specific fault is found by displaying the faulty channel. Press RTN yy, where yy is the two digit channel number being flashed. The display then indicates the red FAILURE LED(s) corresponding to a crowbar, over-temperature, or current limit failure.

3.4.5.3 Flashing Channel 17

A flashing channel 17 indicates multiple channel failures; that is, two or more channels have failed. When this occurs, it is usually the result of the Confidence Test ("E" on VOLTAGE display).

To find the failed channel numbers, the modules must be removed from the chassis until only one of the failed modules is installed.

3.4.5.4 Flashing Channel 18

A flashing channel 18 indicates either a Test board over-run error or a Test board calibration failure. A Test board calibration failure only occurs as a result of executing the Confidence Test and displays an "E3" on the voltage display.

If this "E3" is not displayed, the Test board attempted to measure a voltage of five volts or greater. The processor immediately stopped the test and disconnected the input signal to prevent damage to the Test board A/D converter.

3.4.5.5 Flashing Channel 19

A flashing channel 19 indicates a local key board failure. Occasionally a key is pressed incorrectly, keys are pressed too fast, or the keyboard temporarily malfunctions, sending an illegal key code to the processor. If this occurs simply ignore the failure and repeat the entry sequence.

3.4.5.6 Flashing Channel 20

A flashing channel 20 indicates the processor detected a momentary AC line voltage dip below approximately 95 VAC.

During this dip, the processor temporarily inhibits its own processing to avoid corrupting any channel setups. Suspect the prime AC power cord is loose or prime AC power is underrated for the user's load.

3.5 REMOTE PROGRAMMING IN ABLE

The ABLE (Atlas Based Language Extension) via GPIB provides the Programmer with a more flexible format for numerical entry over that of the keyboard. Channel numbers do not require the leading zeros. Other numeric entries use free format defined in the syntax that follows. In addition, multi-channel control is improved via the GRP and PAR commands. The polarity of voltage entered automatically determines the state of the polarity relay, thus there is no need for a POL parameter.

There are no ENT or EXC commands in remote programming. The remote programming equivalent is the terminator automatically sent by the controller at the end of the programming string. Programming strings sent via the GPIB to the Model AT8000A must be terminated with either a carriage return line feed (hex 0D 0A) and or line feed (hex 0A) and or the GPIB EOI. Talk strings sent from the Model AT8000A are terminated with the universally accepted carriage return line feed (hex 0D 0A) and EOI.

Two types of programming instructions are sent to the Model AT8000A: commands and channel setup parameters. Commands prepare or fetch information related to the channels on a System level. Channel setup parameters are the specific voltage, current, and relay positions desired on the individual channels.

Syntax applicable to remote ABLE version programming is:

<channel>: A one or two digit numeric entry for the channel number. A leading zero is not required for single digit channel numbers. When programming channel numbers, "S" indicates all installed channels. When "S" is used, all installed channels are programmed to the same specified values. This is useful on systems with only modules of the same voltage where programming time is a concern. In this manner, all channels, up to 16, can be programmed in approximately the same amount of time it takes to program one channel.

<value>: A numeric entry in free format. No leading zeros are required; however, a single <space> is required between the parameter and the first number in the value. Consists of up to six digits and plus optional decimal (.) plus an exponent. May be preceded by optional plus sign (+). A negative sign (-) for voltage implements the Polarity relay (if installed). No embedded <spaces> nor commas. The exponent is upper case "E" followed by an optional plus (+) or minus (-) sign followed by one or two digits.

3.5.1 Hexadecimal Programming Values

Voltage and Current programming values are now accepted in hexadecimal numbers. This improves the processor response time from between 20 and 50 ms to approximately 10 ms.

The hexadecimal numbers are defined by being preceded by the capital letter "H". The hexadecimal numbers must all be scaled in relation to the full scale number 3972 (decimal) or F84 (hexadecimal); that is, when sending the value HF84 full scale, the full scale voltage or current is attained; when sending H7C2 (half of HF84), half of full scale voltage or current is attained.

These scaling calculations must be accomplished by the user.

3.5.2 Restrictions on Hexadecimal Values

When using hexadecimal values, voltage, and current values must always be programmed. Unlike decimal values, the processor will not calculate and program default values when either the voltage or current values are omitted. With hexadecimal values, any values omitted are programmed to zero.

Caution must be used to not overheat the modules. The user should adhere to the normal module current derating curves that are in place when using decimal number values. All modules (except for the 7 and 10 volt modules) have reduced current capability when programmed to less than 75% of full scale voltage. The current drops from full scale current at 75% of full scale voltage to 60% of full scale current at zero output volts.

This derating curve is defeated when using hexadecimal numbers. It is possible to bypass the derating curve without overheating the module, but only if the module is not allowed to operate in this condition for a prolonged period of time.

Hexadecimal value programming decreases the processor response time, but it also forces the processor to bypass most of the error checking routines normally performed and puts this responsibility on to the user who must correctly program the AT8000A without damage.

3.5.3 Instrument Commands

Instrument commands are GPIB remote programming instructions which reset the channels, fetch specific information concerning the channels, or configure mutual interaction between (among) channels and, thus, the instrument system. These particular commands do not generate any DC power supply output nor set up any individual channel parameters. Instead, these commands aid in the organization or re-organization of channels. In addition, these commands permit the Programmer/remote ATE controller to look at which type of modules are installed, how they are programmed, and what is occurring within the instrument. The following instrument programming commands are not preceded by any CH (channel) assignments. A command is sent by itself in a programming string. It may not be combined with any other command nor any channel parameters (discussed in the following topic). Note the use of <space> in the following syntax.

3.5.6.1 CNF (Confidence Test) (ABLE Programming)

Syntax:

CNF

Example:

CNF

Perform Confidence Test.

CNF initiates the Confidence Test to execute on all channels. All relays are opened and, upon completion, all channels are reset to zero. Group and Parallel assignments are reset to sixteen independent channels. The display indicates channel 01 upon completion. CNF cancels any RTN or TST.

The Confidence Test performs four separate tests to verify the readiness accuracy of the Model AT8000A DC Power Modules and its own Built In Test function. Test board option A3 must be installed for the last two of these tests. The output isolation relays are opened for the Confidence Test and, afterward, all channel setups are automatically reset to zeros.

The Confidence Test sequence runs Test #1 on all installed channels, starting with the highest channel number and then stepping down through each of the installed channels. If successful, Test #2 is next run on all channels, and so forth through Test #4. Should any channel fail, the Confidence Test continues with the same test # until all of the channels are tested or a second failure is detected. A second failure immediately stops the Confidence Test. Should any failure occur, the Test # does not advance.

There is no front panel display to indicate the Confidence Test is in progress.

Test #1 – Crowbar Fire Test: The processor sequentially addresses each channel and fires its crowbar, waits 30 ms, and reads the channel to ensure that its crowbar was activated.

Test #2 – Current Limit Test: The processor sequentially programs each module to 96.22% of full scale voltage and 0.5% of full scale current, waits 5 ms and reads the channel to ensure it is in the constant current (CURR) mode and that its current limit fail circuitry has been activated.

Test #3 – Test Board Calibration TEST: This test reads the reference voltage of the Built in Test (BIT) board A3 and verifies it to be within $\pm 1.13\%$ of the actual voltage. Channels are not stepped since only the Test board is used. This test takes approximately 7 ms.

Test #4 – Voltage Accuracy Test: The processor sequentially programs each module to 80.56% of full scale voltage and 80.56% full scale current, waits 10 ms, and reads it to be within $\pm 1.61\%$ of the programmed value. The reading takes approximately 7 ms.

Following these tests, all modules are programmed to zero, all relays remain open, and the front panel displays channel 01.

If only one channel fails a particular test, then that channel number flashes on the channel number display of the front panel. If the Confidence Test was invoked from the remote controller, the processor generates an SRQ (numbers

221 through 236) if in the ABLE version. If configured in CIIL Version, the Model AT8000A responds to the STA (status) command with: F07DCS (DEV): CONFIDENCE FAILURE:CH <CHANNEL>.

If more than one channel failed, the processor flashes number 17. If the Confidence Test was invoked from the remote controller, the processor generates the SRQ number 237 in the ABLE version. In the CIIL version, the processor responds to the STA (status) command with: F07DCS (DEV): MULTIPLE FAILURES.

3.5.6.2 RST (Reset Channels) (ABLE Programming)

Syntax:

RST <channel>[[, <channel>]...]
or
RST S

Examples:

RST 4
Reset channel 4.

RST 1,3
Reset channels 1 and 3.

RST S
Reset all installed channels.

RST initiates a reset routine on the specified channels. An "S" specifies all channels. RST simultaneously opens the specified channel relay, programs these channels to zeros, and releases these channels from any group or parallel assignments.

MRST

When modules have been programmed into a PAR set (refer to 3.5.6.4), the command **MRST** must be used to reset the parallel (PAR) grouped modules.

3.5.6.3 GRP (Group Channels) (ABLE Programming)

Syntax:

GRP <channel> [[, <channel>]...]
or
GRP S

Examples:

GRP 1,2,3
Place channels 1, 2, and 3 into a group.

GRP 4,5
Place channels 4 and 5 into another group.

GRP 1,12
Remove channel 1 from the above group and form a new group of channels 1 and 12.

GRP S
Group all channels into one set. Cancel all of the above group assignments.

GRP specifies which channels are to be combined into a set. "S" specifies all channels. Should any run-time failure occur on any channel within this set, all channels within the set are shut down simultaneously to protect the external load circuit and the associated DC Power Modules. Multiple GRP sets may be specified active at the same time.

When any channel is assigned via GRP, that channel's assignment to any other GRP is automatically removed. GRP must be used with the PAR command (see paragraph 3.5.6.4).

RST cancels all GRP assignments into 16 independent channels. Should any run-time failure occur on any channel within a GRP set, all channels within that set are reset and that GRP assignment is canceled.

3.5.6.4 PAR (Parallel Channels) (ABLE Programming)

Syntax:

PAR <channel> [[,channel>]...]
or
PAR S

Examples:

PAR 1,2,3

Place channels 1, 2, and 3 into a PAR set.

PAR 2,6

Place channels 2 and 6 into a PAR set.

PAR S

All channels into one parallel set.

PAR specifies to the processor which sets of channels have their outputs connected in parallel for the benefit of additional output current. "S" specifies all installed channels. PAR does not refer to master/slave modules, but rather individual channels whose outputs are paralleled.

Without the PAR command, should high current levels be drawn, normally one of the channels would reach its programmed upper current value and initiate a protective shut down via the internal processor. This further initiates a Crowbar, drawing tremendous current from the other channels in parallel and quickly defeats the purpose of multiple outputs connected in parallel.

With the PAR command, all of the channels within a particular PAR set are allowed to reach their maximum programmed current before the processor initiates any protective shutdown and signal a fault. The maximum current is equal to the sum of the installed parallel channels.

PAR is canceled upon any failure within the set via the SET or via the MRST command.

Output isolation relays must close and open at precisely the same time by sending the CLS and OPN commands on the same programming line. Since channel outputs are connected together, if any channel's output is activated before a second channel, the second channel will see a voltage that is higher than its own value and consequently immediately Crowbar – possibly causing damage to the module.

IMPORTANT

The PAR command must be used with the GRP command to ensure that any shut down simultaneously includes all channels within the PAR set.

3.5.6.5 TST (Test Channels) (ABLE Programming)

Syntax:

TST <channel> [[,<channel>]...]
or
TST S

Examples:

TST 1
Test channel 1.

TST 1,2
Test channels 1 and 2.

TST S
Test all installed channels.

TST initiates the Model AT8000A processor and BIT (Built In Test) to measure the actual voltage and current on the specified channel(s). "S" specifies all installed channels. Measurements are made at the sense terminals (internal or external, as setup) for voltage and across an internal current path resistor. The Model AT8000A processor signals completion of the measurements and formation of the Test measurement string by setting the instrument SRQ status byte (79 decimal).

To receive the measurement string, the controller sends the GPIB talk address of the Model AT8000A and, in turn, sets itself (controller) to its own GPIB listen address. If the GPIB talk address has been sent to the Model AT8000A prior to completion of the measurement, the SRQ status byte (decimal 79) is not sent (be sure to DIMENSION the controllers string variable large enough to contain the entire returned TST string message).

TST is canceled by CNF and RST. TST requires the optional Built In Test board.

The Model AT8000A returns the TST measurements via the GPIB in the following format:

TST: CHnn=PXX.XXV XX.XXA S R
[,CHnn...] (for modules <100 volts)

TST: CHnn=PXXX.XV XX.XXA S R
[,CHnn...] (for modules ≥100 volts)

Where:

nn = channel number 16 down to 01
(as installed)
P = + or - for the state of the polarity relay
X = decimal number 0 through 9
V = Volts
A = A or C for CURL or CURR respectively
S = I or X for Sense relay Internal or External
R = C or O for output isolation relay closed or open
, = separator between channels.

3.5.6.6 RTN (Return Channels) (ABLE Programming)

Syntax:

RTN<channel> [[,<channel>]...]
or
RTN S

Example:

RTN 1
Form a setup string for channel 1.

RTN 4,6
Form setup strings for channels 4 and 6.

RTN S

Form a setup string for all channels.

RTN initiates the Model AT8000A to assemble a string containing programming setup for each of the specified channels. "S" specifies all installed channels.

To actually send the string, the Model AT8000A must be sent its talker address via the GPIB.

The returned string format is:

RTN: CHnn= PXX.XXV XX.XXA S
R[,CHnn...] (for modules <100 volts)

RTN: CHnn= PXXX.XV XX.XXA S
R[,CHnn...] (for modules ≥100 volts)

Where:

- nn = channel numbers 16 down to 01 (as installed)
- P = + or – for the state of the polarity relay
- X = decimal number 0 through 9
- V = Volts
- A = A or C for CURL or CURR respectively
- S = I or X for Sense relay Internal or External
- R = C or O for output isolation relay closed or open
- , = separator between channels.

3.5.6.7**PWRL**

(ABLE Programming)

Syntax:

PWRL<channel> [[,<channel>]...]
or
PWRL S

Examples:

PWRL 4

Form an identity string for channel 4.

PWRL 2,4

Form identity strings for channels 2 and 4.

PWRL S

Form an identity string for all channels.

PWRL initiates the Model AT8000A to assemble a string identifying the power limits and installed options on each of the specified channel(s). "S" specifies all installed channels. To actually send the string, the Model AT8000A must be sent its talker address via the GPIB.

The returned Power Limit string format is:

PWRL: CHnn=PXX.XXV XX.XA S
R[,<CHnn...] (for modules <100 volts)

PWRL: CHnn=PXXX.XV XX.XA S
R[,<CHnn...] (for modules ≥100 volts)

Where:

- nn = channel number 01 through 16
- P = + or – for polarity relay (+ not installed, – installed)
- X = decimal number from 0 through 9
- V = Volts
- A = Amperes
- S = Sense relay
- R = output isolation relay

3.5.6.8 **VER (Version of Instrument Firmware)**
(ABLE Programming)

Syntax:

VER

Example:

VER

Initiates the instrument to send the VER string.

VER initiates the Model AT8000A to assemble a string identifying the ROM firmware revision within the instrument (available in ABLE only). To actually send the string from the instrument, the Model AT8000A must be sent its talker address via the GPIB.

The returned string format is:

VERSION: X.XX

X.XX = the firmware version (revision) number.

3.5.6.9 **SCR Command to Fire Crowbar**
(ABLE Programming)

Syntax:

SCR [CH]<channel number(s)>
or
SCR S

This command turns on the SCR of the specified channel(s), programs their voltage and current to zero, but leaves all relays in whatever state they were. This condition will remain until the SCR is reset. During the SCR on time, no crowbar or over-voltage failure will be

reported.

The SCR command is used to discharge customer capacitors connected to the output of the power modules.

The SCR can be turned off or reset by any programming command, RST, or CNF. The SCR will not be turned off by query or configuration type commands such as TST, RTN, PWRL, VER, GRP, or PAR.

CAUTION

The user is responsible for module damage due to over-current or current for an extended period of time. See below for the absolute maximum ratings.

The following are the absolute maximum ratings:

Peak forward conduction current = 100 amperes

$I^2 t = 40$ ampere squared seconds from 1 to 8.3 milliseconds.

RMS current = 10 amperes. The SCR used is RCA's part number S2800 or equivalent.

3.5.6.10 **NOX (No Execute)**
(ABLE Programming)

The NOX command will delay execution of the programming string contained therein until either a GET (Group Execute Trigger) command is received or a subsequent string is received without the NOX command.

NOX is used in combination with the GET command, and it can be used to simultaneously trigger events on multiple GPIB controlled devices. The GET command is issued simultaneously to every instrument on the GPIB. Therefore, it is possible to prepare instruments to perform different tasks when activated by the GET command.

Only programming strings (strings starting with CH...) may be externally activated with the NOX command. All other strings may not contain the NOX command.

3.5.6.11 GET (Group Execute Trigger) (ABLE Programming)

The GPIB defined GET command is implemented. The NOX command, when added anywhere to a programming string, delays execution of that string until either a GET command is received, or until another string is received without the NOX command in it.

The GET command is simultaneously issued to every instrument on the bus. Therefore, it is possible to prepare instruments to perform different tasks when activated by the GET command.

The user can activate specified channels to specified setting at the same time that other equipment is activated or triggered. The user can simultaneously execute multiple strings that are received at different times.

3.5.6.12 CiIL Command (ABLE Programming)

The CiIL command will place the AT8000A in the CiIL language operating environment. From the ABLE language, the stand alone CiIL command will enter the CiIL language. That is, once the CiIL command is received, only CiIL commands are accepted and all ABLE commands are rejected as syntax errors until the GAL (Go Alternate Language) command is received, which will then move from CiIL language back to the ABLE language.

3.5.7 Channel Parameters

Channel parameters are the actual setup instructions for each specified channel. Everything a channel needs to know is contained therein. Those items regarding interaction between channels is more of an internal system nature and thus part of the above topic on Instrument Commands.

It is not necessary to reprogram every parameter within a channel setup. The Model AT8000A remembers its most recent setup.

Usually, only one or two parameters need to be updated, but the entire setup does not need to be re-programmed.

It is normal to program several to all channels within the same programming string. The Model AT8000A executes the entire string simultaneously, regardless of content or length. Any channel parameter, syntax, or command error rejects the entire string.

Channel parameters may not be combined with instrument software commands (the above topic) within the same programming string. Voltage and current (CURL or CURR) must be programmed within the same string or the processor will provide default values for the unspecified parameter. Note the use of <space> in the syntax.

Syntax for channel parameters requires a channel (CH) assignment followed by the parameter setup for that channel. Multiple parameters (VOLT, CURR, or CURL relays) or merely one parameter may be included in a single channel's programming string.

Should multiple channels be programmed within one GPIB string, each channel is separated by a comma (.). Individual parameters within a channel setup do not use commas nor any other separator except <space> immediately prior to each parameter.

The syntax is :

```
<channel> <parameter>
[<parameter>...]
or
<channel><parameter>
[<parameter>...] [,<channel>
<parameter>[<parameter>...]
```

3.5.7.1 CH (Channel Number) (ABLE Programming)

Syntax:

```
CH <channel>
or
CH<channel>
```

Examples:

```
CH 1
Channel 1.
```

```
CH4
Channel 4 (note that a leading space is
not required)
```

CH consists of one or two digits to assign a channel number from 1 to 16. A leading zero is not required. A <space> between CH and the channel number is not required. All parameter entries following in the programming string refer to this channel until canceled by a new CH assignment. A new CH assignment is required even if the same channel is desired in the next programming string.

3.5.7.2 VOLT (Voltage) (ABLE Programming)

Syntax:

```
VOLT <value>
```

Examples:

```
CH 16 VOLT 28.55
Set up channel 16 for 28.55 volts.
```

```
CH 3 VOLT 122.2
Set up channel 3 for 122.2 volts.
```

```
CH 2 VOLT -0352E+2
Set up channel 2 for -35.2 volts.
```

VOLT is used to set the voltage. VOLT must be followed by at least one <space> and <value>. When VOLT is programmed and current (either CURL or CURR) are not specified, the default is the maximum CURL allowed for the voltage selected.

3.5.7.3 CURL (Current Limit) (ABLE Programming)

Syntax:

CURL <value>

Examples:

CH1 CURL 4.3

Set up channel 1 for a current limit of 4.3 amperes.

CH3 CURL .1E+2

Set up channel 3 for a current limit of 10 amperes.

CURL sets the Current Limit in amperes. CURL must be followed by at least one <space> and <value>. CURL cancels the Constant Current (CURR) Mode. CURL should be accompanied by a non-zero value, or else a CURL error is likely (virtually any load draws current, even the internal load). CURL must be accompanied by a VOLT setup or a syntax error is generated.

3.5.7.4 CURR (Constant Current) (ABLE Programming)

Syntax:

CURR <value>

Example:

CH1 CURR 12

Set up channel 1 for a constant current of 12 amperes.

CURR sets up the Constant Current value in amperes and enters the Constant Current Mode (CURR LED illuminated). CURR must be followed by at least one <space> and <value>.

When CURR is programmed and a VOLT value is not specified, the default condition is the maximum compliance voltage allowed for the channel (module).

3.5.7.5 CLS (Close) (ABLE Programming)

Syntax:

CLS

Example:

CH7 CLS

Close the output on channel 7.

CH2 CLS, CH3 CLS

Close the outputs on channels 2 and 3.

CLS sets the channel to close its output isolation relay, thus connecting the channel output voltage (and current) to the external load.

3.5.7.6 OPN (Open) (ABLE Programming)

Syntax:

OPN

Examples:

CH3 OPN

Open the output on channel 3.

CH1 OPN, CH2 OPN

Open the outputs on channels 1 and 2.

OPN sets the channel to open its output isolation relay, thus disconnecting output power to the external load.

**3.5.7.7 SENS I (Sense Internal)
(ABLE Programming)**

Syntax:

SENS I

Example:

CH14 SEN I

Directs Channel 14 to use internal voltage sensing.

SENS I sets the channel to open its sense relay, thus sense voltage internally. The internal sense point is before the output relays and load regulation is approximately 20 mV per ampere.

**3.5.7.8 SENS X (Sense External)
(ABLE Programming)**

Syntax:

SENS X

Example:

CH12 SENS X

Directs Channel 12 to use external voltage sensing.

SENS X sets the channel to close its sense relay. Thus, the channel monitors/regulates voltage at the far end of the sense leads which are normally located at the application load. The sense relay automatically switches to internal while the output isolation relay is open. If the channel is programmed for SENS X, the sense relay automatically switches to external when the output isolation relay is closed.

3.5.8 Example Message Strings With ABLE

The following are examples of typical programming strings sent to the Model AT8000A. Recall that the entire string is processed simultaneously for concurrent changes at the individual channel outputs. Only those parameters requiring change are to be sent, thus saving programming time.

Example 1:

**CH1 VOLT 12.4 CURL 1.35 OPN, CH14
CURR .55 VOLT -.276E+2 SENS X
CLS, CH9 VOLT 22.4 OPN SENS I, CH3
CLS CURR 1.12**

Channel 1 to 12.4 volts, a current limit of 1.35 amperes, the output isolation relay open, and no change to the sense relay.

Channel 14 to 0.55 amperes in the Constant Current Mode, the compliance voltage (maximum) is a negative 27.6 volts, external sense relay, and the output isolation relay is closed. The Polarity LED is illuminated due to the negative voltage.

Channel 9 to 22.4 volts at the maximum available (since unspecified) current, the output isolation relay open, and internal sense.

Channel 3 to 1.12 amperes in the Constant Current Mode, the maximum compliance voltage is available (since unspecified), the output isolation relay is closed, and no change to the sense relay.

Example 2:**CH4 CLS, CH5 CLS, CH6 CLS**

Causes the output isolation relays on channels 4, 5, and 6 to close simultaneously.

Example 3:

```
10  DIM A$[200]
20  OUTPUT 717 "RTN S"
30  ENTER 717;A$
40  DISP A$
50  END
```

The memory within the controller (DIM A\$[200]) is reserved to accept the returned string from the Model AT8000A. These characters are more than enough for several channels.

The controller outputs the command string onto the GPIB from controller port 7 (the first 7 of 717) and sends the string "RTN S" to the instrument at GPIB listen address 17 (the second part of 717). The string "RTN" initiates the Model AT8000A processor to formulate a string identifying the instrument setup parameters. The "S" tells the instrument processor that all installed channels are to be included within the formulated string.

ENTER 717 enables the instrument at GPIB address 17 (the Model AT8000A) to talk while the controller now listens. The Model AT8000A processor now sends its message string on the GPIB to whomever is listening (the controller). The controller places the incoming characters from the GPIB into a string A\$. The transfer is completed at the end of the string when the Model AT8000A sends <CR><LF>.

The controller displays the typical string A\$ onto its display as follows:

```
RTN: CH04=-12.35V 04.03A X C,
CH03=+05.00V 10.00A X C,
CH02=+185.4V 00.10C I C,
CH01=+28.00V 03.55A X C
```

3.5.9 Remote ABLE Programming for the Electronic Load Module

This topic applies only to the Electronic Load module. Examples, due to their length and complexity, follow this topic.

Syntax:

CH<channel> CURR <value> [CLS]

Programs the Electronic Load to the Constant Current Mode of operation with a current of <value> in amperes. In this mode, the load conduction will be varied to maintain the current at a constant value up to the maximum power capability or down to the minimum operating voltage of the module.

**3.5.9.1 Constant Current Mode
(ABLE Programming for Electronic Loads)**

Syntax:

**CH<channel> CURR <value1> IRNG
<value2> [CLS]**

Programs the Electronic Load in the Constant Current Mode of operation with high resolution. In this mode, the load conduction will be varied to maintain the current at a constant value up to the maximum power capability or down to the minimum operating voltage of the module.

The current maintained is <value1> in amperes. The IRNG <value2> must be a factor of ten (10) less than the normal full scale current. The maximum constant current <value1> allowed is also limited to ten (10) less than the normal full scale current. A larger value than this will generate a command error. To revert back to the normal high current range mode, enter an IRNG <value2> which greater than 10 times less than the normal full scale current (value2 > I_{max}/10).

For example, on a 60 Volt/60 Amp Electronic Load module, to program the low current range, program IRNG with a <value2> of 6 amps or less. To revert to the normal high current range, program IRNG with a <value2> of higher than 6 amps and equal to or less than 60 amps.

3.5.9.2 Constant Voltage Mode (ABLE Programming for Electronic Loads)

Syntax:

CH<channel> VOLT <value1> [CURL <value2>] [CLS]

or, for remote sensing in this mode,

CH<channel> VOLT <value 1> [CURL <value 2>] [SENS X] [CLS]

Programs the Electronic Load to the Constant Voltage Mode of operation with a constant voltage of <value 1> in volts and an optional current limit value of <value 2> in amperes. The current value should be well above the current limit value of the power supply being used; otherwise, the voltage may fall out of regulation. If the current is not programmed, it will default to the

maximum allowed.

In this mode, the current from the supply will be varied to maintain a constant voltage value up to the maximum power capability of the module. The power supply must be current limited so that when enough current is drawn, the voltage will drop to the programmed value.

Remote voltage sensing may be programmed in this mode to maintain accurate voltage at either the load, the power supply, or at an arbitrary sense point.

3.5.9.3 Constant Resistance Mode (ABLE Programming for Electronic Loads)

Syntax:

CH<channel> RES <value> [CLS]

or, for remote sensing in this mode,

CH<channel> RES <value> [SENS X] [CLS]

Programs the Electronic Load to the constant resistance mode of operation with a resistance of <value> in ohms. In this mode, the load will be programmed to sink a current that is linearly proportional to the voltage applied in order to maintain the programmed resistance value. Remote voltage sensing may be programmed in this mode to maintain accurate loading at the load, at the power supply, or at an arbitrary sense point.

3.5.9.4 **Current Pulse Mode**
(Transient Generator)
 (ABLE Programming for
 Electronic Loads)

Syntax:

**CH<channel> MAXC <value 1> [MINC
 <value 2>] [FREQ <value 3>] [DUTY
 <value 4>] [SLEW <value 5>] [CLS]**

Programs the Electronic Load to the pulsed mode of operation with the maximum current set at <value 1> and the minimum current set at <value 2> in amperes. The frequency is set at <value 3> in Hertz, the duty cycle is set at <value 4>, and the slew rate is set at <value 5>. The minimum current, if not programmed, will default to a value which is ten percent that of the programmed maximum current. The frequency, duty cycle, and slew rate values will default to 200 Hz at 50% duty cycle and the maximum slew rate, respectively, if not programmed.

3.5.9.5 **Voltage Pulse Mode**
(Transient Generator)
 (ABLE Programming for
 Electronic Loads)

Syntax:

**CH<channel> MAXV <value1> [MINV
 <value2>] [SENS X!|I] [FREQ <value3>]
 [DUTY <value4>] [SLEW <value5>]
 [CLS]**

Programs the Electronic Load to the Voltage Pulse mode of operation with the maximum voltage set at <value 1> in volts and the minimum voltage set at <value 2>. The frequency is set at <value 3> in Hertz, the duty cycle is set at <value 4> and the slew rate is set at <value 5> in Amperes per microseconds.

The minimum voltage, if not programmed will default to a value which is ten percent (10%) that of the programmed maximum voltage. The frequency, duty cycle and slew rate values will default to 200 Hz, fifty percent (50%) duty cycle and the maximum slew rate, respectively, if not programmed.

The duty cycle <value4> should be in percent such as 50 for 50% or 10 for 10%.

The slew rate programmable values are:

60V/60A: 1.0, 0.5, 0.1 and 0.01
 Amp/ μ s.

120V/20A: 2.0, 1.0, 0.1 and 0.01
 Amp/ μ s.

If a value other than these is programmed, the main microprocessor will select the slew rate setting that is closest to the programmed value. The slew rate in this mode is largely dependent on the speed of the power supply used; to move from the minimum voltage to the maximum voltage, the load simply stops drawing current is up to the power supply to raise the voltage at its speed to the maximum voltage programmed.

External voltage sensing may be programmed in this mode to maintain accurate voltage either at the load, at the power supply or at an arbitrary sense point.

**3.5.9.6 Resistance Pulse Mode
(Transient Generator)
 (ABLE Programming for
 Electronic Loads)**

Syntax:

**CH<channel> MAXR <value1> [MINR
 <value2>] [SENS X!|] |[FREQ <value3>]
 [DUTY <value4>] [SLEW <value5>]
 [CLS]**

Programs the Electronic Load to the Resistance Pulse Mode of operation with the maximum resistance set at <value 1> in ohms and the minimum resistance set at <value 2>. The frequency is set at <value 3> in Hertz, the duty cycle is set at <value 4> and the slew rate is set at <value 5> in Amperes per microseconds. The minimum voltage, if not programmed will default to a value which is ten percent (10%) that of the programmed maximum voltage. The frequency, duty cycle and slew rate values will default to 200 Hz, fifty percent (50%) duty cycle and the maximum slew rate, respectively, if not programmed.

The duty cycle <value4> should be in percent such as 50 for 50% or 10 for 10%.

The slew rate programmable values are:

60V/60A: 1.0, 0.5, 0.1 and 0.01
 Amp/ μ s.

120V/20A: 2.0, 1.0, 0.1 and 0.01
 Amp/ μ s.

These values are mostly applicable to the current pulse mode. If a value other than these is programmed, the main microprocessor will select the slew rate setting that is closest to the programmed value.

External voltage sensing may be programmed in this mode to maintain accurate resistance either at the load, at the power supply or at an arbitrary sense point.

**3.5.9.7 Short Circuit Mode
 (ABLE Programming for
 Electronic Loads)**

Syntax:

CH<channel> SHORT [CLS]

Programs the Electronic Load to a simulated short circuit by programming the maximum current possible for the module.

**3.5.10 Examples of Remote
Programming of the
Electronic Load Module in
ABLE**

The following examples are written for an HP type controller with a modified version of the BASIC language. For other types of controllers, the reader should refer to the messages contained inside quote marks ("") and to the program comments below.

It is assumed the controller is set at GPIB address seven (7) and the AT8000 system is at the factory set address of seventeen (17 decimal).

The examples are referenced to an AT8000 system with two Electronic Load modules installed. A 60V/60A in channel 5 and a 120V/30A in channel 2.

3.5.10.1 Setting Up the System

Programming Example:

```

10 DIM A$[200]
20 CLEAR (717)
30 OUTPUT 717;"CNF"
40 WAIT 1000
50 A= SPOLL (717)
60 IF A <> 0 THEN DISP "AT8000
  FAILURE =" & A
70 OUTPUT 717;"PWRL S"
80 ENTER 717; A$
90 DISP A$
100 OUTPUT 717;"VER"
110 ENTER 717; A$
120 DISP A$
    
```

Program Comments:

- Line 10: Enlarge variable A\$ for later use.
- Line 20: Reset system and all modules.
- Line 30: Perform a Confidence Test to ensure system operation.

NOTE

A CNF request on DC loads will open output relays and reset the loads to zero (idle). It will not perform a self test.

- Line 40: Wait 1 second for test completion.
- Line 50: Do Serial Poll to get test result. Zero= all pass.
- Line 60: Display failure message if any.

- Line 70: Send query to get the power limits of all modules installed.
- Line 80: Receive Power Limit string.
- Line 90: Display string. String would consist of the following: PWR: CH05=+60.00V 60.00A S R 300.0W 9999H, CH02=+120.0V 30.00A S R 300.0W 9999H

Where: Equals:

PWR: Power Limit string to follow.

CH05= Channel 5 consists of: +60.00V (60 volts maximum with no polarity relay) and 60.00A (60 amperes maximum).

S External Sense capability.
R Input Isolation Relay capability.

300.0W 300 Watts maximum power.

9999H 9999 Hz maximum frequency.

CH02= Channel 2 consists of: +120.0V (120 volts maximum with no polarity relay) and 30.00A (30 amperes maximum).

S External Sense capability.
R Input Isolation Relay capability.

300.0W 300 Watts maximum power.

9999H 9999 Hz maximum frequency.

Line 100: Send query to get firmware version.

Line 110: Receive firmware version string.
 Line 120: Display string. String would consist of the following:

VERSION: 3.02 08-15-90

Where: E

3.02 Firmware version number.

08-15-90 Firmware release date.

3.5.10.2 Programming the Constant Current Mode

Programming Example:

```
130 OUTPUT 717;"CH2 CURR 29.5
    CLS, CH5 CURR 1567E-02 OPN
    SENS X"
140 OUTPUT 717;"RTN S"
150 ENTER 717; A$
160 DISP A$
```

Program Comments:

Line 130: Program channel 2 for 29.5 amperes, close its input isolation relay and program channel 5 to 15.67 amperes, open its isolation relay, set external/remote sense.

Line 140: Send query to get programming status of all modules.

Line 150: Receive program status string.

Line 160: Display string. String would consist of the following:

"RTN: CH05=+19.14V 15.67A X O C
 300.0W, CH02=+010.1V 29.50A I C C
 300W"

Where: Equals:

RTN: Return programming status to follow.

CH05= Channel 5 is programmed for: + 19.14V (19.14 volts maximum for 300 Watts) and 15.67A (15.67 amperes).

X EXternal/remote sense.

O Input isolation relay

Open.

C Constant Current mode.

300.0W 300 Watts maximum power.

CH02= Channel 2 is programmed for: +010.1V (10.1 volts maximum for 300 Watts) and 29.50A (29.5 amperes).

I Internal/local sense programmed.

C Input isolation relay Closed.

C Constant Current mode.

300.0W 300 Watts maximum power.

3.5.10.3 Programming the Constant Voltage Mode

Programming Example:

```
170  OUTPUT 717; "CH5 VOLT 15.5
      CLS, CH2 VOLT 100 SENS X"
180  OUTPUT 717; "TST 2"
190  ENTER 717; A$
200  DISP A$
```

Program Comments:

Line 170: Program channel 5 for Constant Voltage mode of 15.5 volts, current limit value will default to its maximum of 60 amperes, close its input isolation relay and program channel 2 for Constant Voltage mode of 100 volts, current limit value will default to its maximum of 60 amperes and sense is external.

Line 180: Send query to measure input voltage and current of channel 2 (measurement result dependent on DC power applied).

Line 190: Receive measurement result string.

Line 200: Display string. String would consist of the following:

```
TST: CH02=+100.0V 00.50A X C V
050.0W
```

Where:

TST: Test/measurement reading to follow.
 CH02= Channel 5 input values are: +100.0V (100 volts) and 00.50A (0.5 amperes).
 X EXternal/remote sense
 C Input isolation relay Closed.
 V Constant Voltage mode.
 050.0W 50 Watts input DC power.

3.5.10.4 Programming the Constant Resistance Mode

Programming Example:

```
210  OUTPUT 717; "RST 2"
220  OUTPUT 717; "CH5 RES 5.67
      SENS I"
230  OUTPUT 717; "RTN 5"
240  ENTER 717; A$
250  DISP A$
```

Program Comments:

Line 210: Reset channel 2 to quiescent conditions.

Line 220: Program channel 5 for constant resistance of 5.67 Ω with internal sense.

Line 230: Send query to get programming status of channel 5.

Line 240: Receive program status string.

Line 250: Display string. String would consist of the following:

RTN: CH05=+05.67O 07.27A I C R
300.0W

Where: Equals:

RTN: Return program status to follow.

CH05= Channel 5 is programmed for: +05.67O (5.67 Ω) and 07.27A (7.27 amperes maximum at 300 Watts).

I Internal/local sense.
C Input isolation relay Closed.
R Constant Resistance mode.
300.0W 300 Watts maximum power.

3.5.10.5 Programming the Constant Low Current Range Mode

Programming Example:

```
260 OUTPUT 717;"CH2 IRNG 5
    CURR 3.456 CLS"
270 OUTPUT 717;"RTN 2"
280 ENTER 717; A$
290 DISP A$
```

Program Comments:

Line 260: Program channel 2 to the low current range for 3.456 amperes and close its input isolation relay.

Line 270: Send query to get programming status of channel 2.

Line 280: Receive program status string.

Line 290: Display string. String would consist of the following:

"RTN: CH02=+60.00V 3.456A I C C
207.4W"

Where: Equals:

RTN: Return programming status to follow.

CH02= Channel 2 is programmed for: +60.00 (60 volts maximum) and 3.456A (3.456 amperes).

I Internal/local sense programmed.

C Input isolation relay Closed.

C Constant Current mode.

207.4W 207.4 Watts maximum power.

3.5.10.6 Programming the Current Pulse Mode (Transient Generator)

Programming Example:

```
300 OUTPUT 717; "CH5 MAXC 20
    MINC 10 FREQ 2000 DUTY 70
    SLEW 0.5"
310 OUTPUT 717; "RTN 5
320 ENTER 717; A$
330 DISP A$
```

Program Comments:

Line 300: Program channel 5 in current pulse mode to switch between 20 amperes and 10 amperes at 2 kHz, 70% duty cycle and with a slew rate of 0.5 Amp/μs.

Line 310: Send query to get program status.

Line 320: Receive program status string.

Line 330: Display string. String should consist of the following:

RTN: CH05=+20.00A 10.00A I C P
2000H 70.00D 0.500A/US

Where: Equals:

RTN: Return program status to follow).
CH05= Channel 5 is programmed for: +20.00A (20 amperes maximum current).
10.00A 10 amperes minimum current.
I Internal/local sense).
C Input isolation relay Closed.
P Pulse mode.
2000H 2 kHz frequency.
70.00D 70% Duty cycle.
0.500A/US 0.5 Amp/ μ s slew rate.

3.5.10.7 Programming the Voltage Pulse Mode (Transient Generator)

Programming Example:

340 OUTPUT 717; "CH5 MAXV 20 MINV 10"

Program Comments:

Line 340: Program channel 5 in the voltage pulse mode to switch between 20 volts and 10 volts at the default of 200 Hz, 50% duty cycle and the maximum slew rate.

3.5.10.8 Programming the Resistance Pulse Mode (Transient Generator)

Programming Example:

350 OUTPUT 717; "CH5 MAXR 5 MINR 2"

Program Comments:

Line 350: Program channel 5 in the resistance pulse mode to switch between 5 Ω and 2 Ω at the default of 200 Hz, 50% duty cycle and the maximum slew rate.

3.5.10.9 Programming the Short Circuit Mode

Programming Example:

360 OUTPUT 717; "CH5 SHORT"
370 OUTPUT 717; "RTN 5"
380 ENTER 717; A\$
390 DISP A\$

Program Comments:

Line 360: Program channel 5 for the short circuit mode.
Line 370: Send query to get program status.
Line 380: Receive program status string.
Line 390: Display string. String should consist of the following:

RTN: CH05=+00.00V 60.00A I C S

Where: Equals:

RTN: Return program status to follow.

CH05= Channel 5 is programmed for: +00.00V (0 volts) and 60.00A (60 amperes maximum).

I Internal/local sense.

C Input isolation relay Closed.

S Short circuit mode.

3.5.11 Service Request Status Bytes

The Model AT8000A ABLE version sends all of its error and service request messages via the Service Request (SRQ) on the GPIB. These include programming errors, run-time failures and requests to talk to its internally formulated message string.

Application software should be written to periodically check for Service Requests (GPIB SRQ flag) after performing Confidence test and channel programming. This assures the instrument is completely functional and the programming setups are accepted.

Occasional checks during normal operation verify the presence of any run-time faults. Be sure to allow sufficient processing time (usually just a few hundred milliseconds) within the instrument, when programming channel setups and for lengthy activities such as TST and CNF. If insufficient time is allotted prior to reading the SRQ byte, the instrument processor may have not yet completed its processing. Thus, the SRQ byte is not necessarily updated in time when it is read by the controller.

The SRQ message consists of a single byte of information. In the event an old message byte has not been read, the Model AT8000A retains only the most recent one. Upon being read, the SRQ message is cleared and SRQ line is released. Serial poll activities are handled separately from normal programming strings. Each controller, and its own language subset, implements the serial poll via different commands.

Some treat the SRQ flag as a flag for occasional inspection. Others may treat the SRQ as an interrupt for immediate polling and thus immediate attention. However, each should return the SRQ status byte to the program for analysis.

Should the received status byte not correctly interpret messages as listed below, suspect that the controller (or its software driver) is not monitoring all eight data bits on the GPIB. The last three columns of Table 3-2 use the full eight data lines.

Table 3-2. Service Request Messages

SRQ BYTE		DESCRIPTION									
DEC	HEX										
73	49	Emergency Shutdown									
74	4A	Syntax error									
75	4B	Command error									
76	4C	Input buffer overflow									
77	4D	Multiple channel failures									
78	4E	Test measurement system (BIT) overflow									
79	4F	Send talk address so message may be sent									
80	50	Low AC Input Power									
<u>CHAN</u>		<u>CROWBAR</u>		<u>CURL</u>		<u>NOT INSTALL</u>		<u>CNF TEST</u>		<u>THERMAL</u>	
		DEC	HEX	DEC	HEX	DEC	HEX	DEC	HEX	DEC	HEX
1		81	51	101	65	201	C9	221	DD	240	F0
2		82	52	102	66	202	CA	222	DE	241	F1
3		83	53	103	67	203	CB	223	DF	242	F2
4		84	54	104	68	204	CC	224	E0	243	F3
5		85	55	105	69	205	CD	225	E1	244	F4
6		86	56	106	6A	206	CE	226	E2	245	F5
7		87	57	107	6B	207	CF	227	E3	246	F6
8		88	58	108	6C	208	D0	228	E4	247	F7
9		89	59	109	6D	209	D1	229	E5	248	F8
10		90	5A	110	6E	210	D2	230	E6	249	F9
11		91	5B	111	6F	211	D3	231	E7	250	FA
12		92	5C	112	70	212	D4	232	E8	251	FB
13		93	5D	113	71	213	D5	233	E9	252	FC
14		94	5E	114	72	214	D6	234	EA	253	FD
15		95	5F	115	73	215	D7	235	EB	254	FE
16		96	60	116	74	216	D8	236	EC	255	FF
MULTI				237							
BIT		218	DA	238							

MULTI = Multiple Channels BIT = Built In Test Board

3.6 REMOTE PROGRAMMING WITH CIIL

CIIL (Control Interface Intermediate Language) is a form of generic ATE (Automatic Test Equipment) language which defines the structure of message strings going to and from instruments on the GPIB. This structure encourages certain longevity in programming for interchangeable instruments.

The Model AT8000A System internally supports several channels of DC power supplies and DC loads. In addition to providing voltage and current, the Model AT8000A coordinates several activities

on an internal instrument system level including fault detection and handling, relay control, BIT, real time monitoring or channel activity, and both setup and error reporting.

For the purpose of CIIL, the Model AT8000A support of internal system activities is via CIIL "opcodes". The Model AT8000A specific instrument operation is defined via the CIIL "noun" DCS (Direct Current Supply) or IMP (Impedance). Contents of the programming string relating to instrument operation use terms called "noun modifiers". These latter terms are the familiar VOLT, CURR, etc.

In the remote CIIL version, any Model AT8000A run-time fault always sets the DFI (Direct Fault Indicator) and resets all channels. The DFI signals the remote controller that the Model AT8000A has internally detected a fault and automatically shut down all channels. The controller needs to check the DFI periodically and, if flagged, must clear it via the GPIB using the STA opcode.

The CIIL hardware configuration generally uses optional MS type connectors for AC input and DC output/sense. However, these MS connectors are not always required. These connectors, including DFI/Shutdown, are identified in Sections I and II.

CIIL also has a remote Shutdown input signal pair on the DFI/Shutdown connector. The remote controller or any relay closure may be used to initiate an instrument reset. This reset is comparable to the RST command.

CIIL programming strings use free format numerical entry as defined in the syntax that follows. The polarity of voltage entered determines the state of the polarity relay.

There are no ENT or EXC commands in remote programming. The remote programming equivalent is the terminator automatically sent by the computer at the end of the programming string. Programming strings must be terminated with either carriage return line feed (hex 0D0A) or line feed (hex 0A). Talk strings sent from the Model AT8000A are terminated with the universally accepted carriage return line feed. EOI is not supported in CIIL and neither is serial poll.

The syntax applicable to remote CIIL programming is:

:CH<channel>: Channel assignment consists of a colon immediately followed by CH and a one or two digit numeric entry for the channel number. No leading <spaces> are permitted for the channel number. No embedded <spaces> are permitted. A leading zero is not required for single digit channel numbers. "S" (all channels) is not permitted in CIIL.

<value>: Numeric entry in free format. No leading zeros required. Consists of up to six digits and plus optional decimal (.) plus an exponent. May be preceded by optional plus sign (+). A negative sign (-) for voltage implements the polarity relay (if installed). No embedded spaces nor commas. Exponent is upper case "E" followed by one or two digits.

3.6.1 Nouns

The CIIL nouns "DCS" or "IMP" must be used whenever the programming string contains setup (SET) or reset (RST) of parameters for an individual channel. The noun "DCS" indicates the string contains information which applies only to the Direct Current Supply function (FNC) capability of the instrument. The noun "IMP" indicates the string contains information which applies only to the programmable DC loads function (FNC) capability of the instrument. The following programming strings refer to "DCS" only but apply to "IMP" as well.

The Model AT8000A supports no other CIIL function (FNC) noun. Other nouns received by the Model AT8000A generate a syntax error.

3.6.2 Opcodes

Programming strings sent from the controller to an instrument via the GPIB are referred to as operational codes, or "opcodes" for short. Opcodes command an instrument to perform some internal task or setup. Such a command may involve an overall reset of the instrument, setup of DCS or IMP channel parameters, formulate any error response message to send back to the controller, etc.

3.6.3 Instrument Level

CIIL opcodes which apply to the internal system capabilities of the Model AT8000A and not its specific function are simple and brief to program. These five opcodes are CNF, IST, STA, CLS, and OPN.

3.6.3.1 CNF (Confidence Test) (CIIL Programming)

Syntax:

CNF

Example:

CNF

Perform the Confidence Test.

3.6.3.2 IST (Internal Self Test) (CIIL Programming)

Syntax:

IST

Example:

IST

Perform the Confidence Test (IST is identical to CNF).

3.6.3.3 STA (Status) (CIIL Programming)

Syntax:

STA

Example:

STA

Reset the DFI relay and formulate a status message.

STA initiates the Model AT8000A to reset its DFI flag relay and send any fault message to the controller. The status message contains the most recent fault since the last status opcode command. The status message is reset to a single <space> after sending its fault message.

If no faults occurred, the status message is a single <space>. Refer to paragraph 3.6.14 for a list of available Model AT8000A status messages. The Model AT8000A processor sends the formulated status message upon receipt of the instrument's GPIB talk address.

3.6.3.4 **CLS (Close Output Isolation Relay)**
(CIIL Programming)

Syntax:

CLS :CH<channel>

Examples:

CLS :CH1

Connect the channel 1 output to the external load.

CLS :CH16

Connect the channel 16 output to the external load.

CLS :CH 4

Syntax error due to a leading space prior to 4.

CLS closes the output isolation relay on the specified channel, thereby connecting the power supply channel to the external load. The opening and closing of the output isolation relays is considered an internal system activity and not a DCS or IMP setup function. A CH0 assignment switches all installed channels simultaneously.

Any associated sense relay switching (via FORW) is performed simultaneously with this opcode. TWOW and FORW sense relay switching may also occur separately via the FNC opcode. However, the sense relay is automatically switched to internal (temporary TWOW) while the output isolation relay is open. If the sense relay is programmed for external voltage sensing (FORW), the sense relay is automatically switched to external simultaneously with CLS.

3.6.3.5 **OPN (Open Output Isolation Relay)**
(CIIL Programming)

Syntax:

OPN :CH<channel>

Examples:

OPN :CH7

Disconnects channel 7 from the external load.

OPN :CH16

Disconnects channel 16 from the external load.

OPN is identical to CLS above except this command opens the specified channel relay and sense relay.

3.6.4 **Functional Levels**

The last five opcodes directly involve the Direct Current Supply (DCS) or DC load (IMP) capability of the instrument. Thus, the CIIL noun is required with these opcodes. These five opcodes perform only two tasks – reset and setup channels. It is simple to reset channel setup parameters (noun modifiers) to start up defaults. The RST opcode performs this task.

To setup channel parameters (called noun modifiers in CIIL) the function (FNC) opcode is required. The FNC opcode is then followed by one or more SET opcodes. Each SET opcode sets up one noun modifier (parameter) of the selected channel. The Model AT8000A supports only the CIIL nouns DCS and IMP. Any other CIIL noun generates a syntax error. IMP applies wherever DCS is used.

3.6.4.1 RST (Reset Channel) (CIIL Programming)

Syntax:

RST DCS :CH<channel>

Example:

RST DCS :CH12
Reset channel 12.

RST opens all relays on the specified DCS channel and resets its setup to all zeros. The specified channel is reset to VOLT = 0, CURL = maximum of the installed channel, CURR = 0 and CURR mode off, TWOW, and open output isolation relay. Channel 0 denotes all channels. Note the use of <space> separators in the syntax.

3.6.4.2 FNC (Function) (CIIL Programming)

Syntax:

FNC DCS :CH<channel> SET<noun modifier and value> [SET...]

Examples:

FNC DCS :CH3 SET VOLT 5.123 SET CURL 3.21 SET TWOW
Channel 3 to 5.123 volts, current limit to 3.21 amperes and internal sense relay.

FNC DCS :CH15 SET FORW
Channel 15 to external sense.

FNC is a prefix for programming channel noun modifiers (parameters). FNC is followed by a noun (only DCS) and the channel number. Note the use of <space> separators in the syntax. Multiple SET opcodes may be included

within one FNC opcode command string. Channel noun modifier setups are performed on each channel per function string. It is not necessary to repeat the entire channel setup if only one noun modifier (or a few) require updating.

3.6.4.3 SET (Set) (CIIL Programming)

Syntax:

SET VOLT|CURL|CURR <value>
or
SET TWOW|FORW

Example:

See FNC above.

SET is a prefix for noun modifiers. SET must be part of a FNC opcode structure and may be repeated within this FNC structure. Only one noun modifier is modified (setup) per set. Multiple noun modifiers may be modified with a programming string as long as each noun modifier is preceded by its own SET. Note the use of <space> separators in the syntax.

3.6.4.4 SRX (Set Maximum) (CIIL Programming)

Syntax:

SRX <value>

Implemented identically to SET above.

3.6.4.5 SRN (Set Minimum) (CIIL Programming)

Syntax:

SRN <value>

Implemented identically to SET above.

3.6.5 Noun Modifiers

Noun modifiers are the parameters (VOLT, CURL, TWOW, etc) which setup a channel. Since the Model AT8000A is a Direct Current Supply, its noun is DCS. Its noun modifiers are thus parameters of voltage, current, and voltage sense relay selection. The output isolation relay is under instrument system control via the OPN and CLS opcodes.

Noun modifiers are only used one at a time with the SET opcode. Several noun modifiers may be used in the same FNC opcode string since each has its own SET. These noun modifiers are: VOLT, CURL, TWOW, and FORW.

3.6.5.1 VOLT (Voltage) (CIIL Programming)

Syntax:

**FNC DCS :CH<channel> SET VOLT
<value> [SET...]**

Example:

FNC DCS :CH5 SET VOLT -2.54
Set channel 5 to -2.54 volts, current limit (CURL) mode at maximum current.

VOLT is the voltage setup value. Note the use of <space> separators in the syntax. When VOLT is programmed without a CURL or CURR, the default is the maximum CURL allowed or the voltage value selected.

3.6.5.2 CURL (Current Limit) (CIIL Programming)

Syntax:

**FNC DCS :CH<channel> SET CURL
<value> [SET...]**

Example:

FNC DCS :CH11 SET CURL 1.4E+1
Set channel 11 to a new current limit of 14 amperes.

CURL is the current limit setup value and enters the CURL mode. Note the use of <space> separators in the syntax. CURL must be programmed with a VOLT value or a Command Error will be generated.

3.6.5.3 CURR (Constant Current) (CIIL Programming)

Syntax:

**FNC DCS :CH<channel> SET CURR
<value> [SET...]**

Example:

FNC DCS :CH3 SET CURR 1.20
Set channel 3 to 1.2 amperes in the Constant Current Mode and the compliance voltage default to the maximum value of the module.

CURR is the constant current setup value and enters the CURR mode. Note the use of <space> separators in the syntax. When CURR is programmed without a VOLT value, the default is the maximum compliance voltage allowed. The front panel CURR LED is illuminated.

3.6.5.4 TWOW (Two Wire - Internal Voltage Sense) (CIIL Programming)

Syntax:

FNC DCS :CH <channel> SET TWOW [SET...]

Example:

FNC DCS :CH6 SET TWOW
Set channel 6 to internal sense.

TWOW selects the internal voltage sense relay position. The sense relay is initialized (RST, CNF, RST, and power on reset) to the TWOW position. Only a FORW opcode with an OPN (output isolation relay) opcode changes this sense relay from internal (TWOW). The front panel SEN LED is not illuminated.

3.6.5.5 FORW (Four Wire - External Voltage Sense) (CIIL Programming)

Syntax:

FNC DCS :CH<channel> SET FORW [SET...]

Example:

FNC DCS :CH12 SET FORW
Set channel 12 to external sense.

FORW selects the external voltage sense position. Requires the output isolation relay to also be closed (CLS). The sense relay temporarily switches to internal while the channel output isolation relay is open (OPN). The front panel SEN LED is illuminated.

3.6.6 Remote Measurement Function (CIIL Programming)

The actual load voltage and current values can be measured via remote command. The measurement system was implemented as described in the MATE System Control Interface Standard No. 2806763 of 21 June 1988.

Syntax:

CONTROLLER	F N C D C S
	V O L T ; C U R R
	: C H < c h a n n e l
	n u m b e r >
CONTROLLER	CLS :CH<channel
	number>
CONTROLLER	INX VOLT;CURR
AT8000A	1
CONTROLLER	FTH VOLT;CURR
AT8000A	TST: CH<channel
	number>=+ -<4
	digits>V;A I;X O;C
CONTROLLER	R S T D C S
	V O L T ; C U R R
	: C H < c h a n n e l
	n u m b e r >

Explanation:

FNC DCS VOLT :CH1
Programs channel 1 for voltage.

CLS :CH1
Starts the measurement protocol.

INX VOLT

Initiates the measurement for voltage or current.

1

Consists of <space><1> and is the time in seconds that the AT8000A takes to perform the measurement.

FTH VOLT

Fetches the answer.

TST: CH01 -45.67V X C

The answer where:

- = Reversed polarity.
- V = Indicates volts (A = amperes)
- X = External sense (I = Internal sense)
- C = Closed output relay (O = Open output relay)

RST DCS VOLT :CH1

Reset or conclusion of measurement.

3.6.7 Software Parallel Function (CIIIL Programming)

The Parallel function allows the user to parallel the outputs of modules of the same rated voltage (may be hardware master/slave combinations) to achieve higher output current.

Syntax:

**FNC DCS :CH<channel number> SET
PARL <c1> <c2> <c3>...SET**

Where:

- <c1> = The master channel number.
- <c2> = Slave channel number (may be one or two digits).
- <c3> = Slave channel number.

Example:

**FNC DCS :CH9 SET VOLT 40 SET
CURL 25 SET FORW SET PARL 9 1 16
5 12**

The above example parallels 5 volt/5 amp modules (channel 1, 5, 9, 12, and 16) and defines channel number 9 to be the master. It also programs the set to 40 volts, current limit of 25 amperes, and remote sense.

3.6.8 Parallel Flexibility (CIIIL Programming)

Channels are not limited to a chassis. The user may parallel a module in a master chassis to a module in an extender chassis or the user may parallel two modules in two different extender chassis.

A channel to be paralleled may consist of a set of hardware master/slave modules (dedicated master/slave modules limited to one chassis and connected internally with a ribbon cable).

The user need only program the master channel number. The master channel number will behave as if it were a module with the higher current capability of the combined set.

The microprocessor will proportionately divide the programmed current between all the paralleled modules. The slave channel numbers, once paralleled, will behave as non-installed modules. They may not be specifically addressed until the parallel command has been reset or canceled. The paralleled channels are automatically grouped together. If a failure occurs on one of the channels, it will behave as a failure on all channels in

the set. Consequently, all channels would be reset to the quiescent state simultaneously.

The parallel command is only reset or canceled by the Device Clear (DCL), the Selected Device Clear (SDC), and the Reset (RST) commands. The commonly used CNF/IST (Confidence Test/Internal Self Test) command may be used throughout a test program without the need to re-issue the PARL command.

3.6.9 Parallel Restrictions in CIL

Paralleled modules must be more closely calibrated for voltage accuracy than the specification of a single module if they are to stay within the regulation specification. Each module to be paralleled must be within 1 or 2 mV of each other when programmed to the same value. The regulation between no load and full load of a paralleled set of modules will vary between the highest voltage module (at no load) and the lowest voltage module (at full load).

When using remote (external) sense, all sense lines must be tied together and connected to the power lines only at the point where regulation is desired. In other words, the positive sense output of a module must be tied to all other positive sense outputs of every module in the paralleled set, and then connected to the positive output power line at the sense point. The same applies to the negative sense output lines.

3.6.10 Software Group Function (CIL Programming)

Syntax:

**NC DCS :CH<channel number> SET
GRUP <c1> <c2> <c3>...SET**

<c1, <c2>, and <c3> are one or two digit channel numbers separated by spaces)

Example:

**FNC DCS :CH9 SET VOLT 40 SET
CURL 5 SET FORW SET GRUP 9 1 16
5 12**

The above programmed string groups channels 1, 5, 9, 12, and 16 together. It also programs channel 9 to 40 volts, current limit of 5 amperes and remote sense.

Channels may be grouped to run independent test on different boards where each group is never affected by failure or events occurring on other groups. The Group function allows the user to specify which channels get reset to quiescent conditions in the event of a failure. For example, suppose that channels 1 and 2 are supplying power to test board A and channels 3 and 4 are supplying power to test board B. If a failure occurs on channel 1, then channels 1 and 2 should be reset to terminate the test on board A, but there is no need to also terminate the test on board B. This can be accomplished by grouping channels 1 and 2 into one group and channels 3 and 4 into another group.

3.6.11 Group Flexibility (CIIL Programming)

Channels are not limited to a chassis. The user may group a module in a master chassis to a module in an extender chassis, or the user may group two modules in two different extender chassis. A channel to be grouped may consist of a set of hardware master/slave modules (dedicated master/slave modules limited to one chassis and connected internally with a ribbon cable).

The group command is only reset or canceled by the Device Clear (DCL), the Selected Device Clear (SDC), and the Reset (RST) commands. The commonly used CNF/IST (Confidence Test/Internal Self Test) command may be used throughout a test program without the need to re-issue the PARL command.

3.6.12 GAL (Go Alternate Language) (CIIL Programming)

Syntax:

GAL

The GAL command will place the AT8000A in the commercial ABLE language operating environment. From the CIIL language, the stand alone GAL command will enter the ABLE language. That is, once the GAL command is received, only ABLE commands are accepted and all CIIL commands are rejected as syntax errors until the "CIIL" command is received to switch back to the CIIL language.

In the ABLE language, the user can access all the commands that are not available in CIIL.

3.6.13 Remote Programming Example With CIIL

The following CIIL version example demonstrates software design in communicating with the Model AT8000A. Good programming layout makes frequent use of the STA opcode to identify possible instrument setup and run-time errors. The Model AT8000A, just as with any other instrument, requires internal processing time, relay settling time, etc., which need to be provided for within the controller software as a WAIT statement.

The duration of the WAIT statement is longest for CNF, IST, and RST opcodes since multiple activities occur per installed channel. Actual times are best experimentally determined per the user's particular application.

Examples:

100 DIM A\$[200]

Reserve memory space for incoming messages.

200 GOSUB 2000

Check for any existing STA message.

220 OUTPUT 717 "CNF"

Perform Confidence Test.

240 WAIT (600)

Give time to perform the CNF on all channels.

260 GOSUB 2000

Check for any STA due to CNF.

280 OUTPUT 717 "FNC DCS :CH01
SET VOLT 56.37 SET CURL 2.12 SET
FORW"

300 OUTPUT 717 "FNC DCS :CH16
SET VOLT -0.5637E+02 SET CURL
1.98"

320 OUTPUT 717 "FNC DCS :CH5 SET
CURR 14.95"

340 WAIT (200)

Instrument processing and settling
(varies).

360 GOSUB 2000

Check for any errors.

380 OUTPUT 717 "CLS :CH1"

400 OUTPUT 717 "CLS :CH16"

420 OUTPUT 717 "CLS :CH05"

430 OUTPUT 717 "FNC DCS :CH5 SET
FORW"

External sense.

440 WAIT (250)

Plenty of settling time.

460 GOSUB 2000

Check for any errors.

480 OUTPUT 717 "RST DCS :CH5"

Reset channel 5.

500 WAIT (200)

Allow time for RST process within the
instrument.

520 GOSUB 2000

Check for any errors.

1000 END

2000 OUTPUT 717 "STA"

Tell the instrument to form a status
message.

2010 INPUT 717 A\$

Sends the GPIB TALK address to the
instrument.

2020 DISP A\$

The A\$ string should be a <space> if no
message.

2030 RETURN

3.6.14 Status Messages With CII

The STA opcode enables the Model AT8000A processor to send a status (or fault) message back to the controller. It is important to periodically check the instrument for any faults such as syntax, overtemps, CURLs, etc. Should multiple faults occur, only the most recent is remembered. The DFI (Direct Fault Indicator) flags only run-time faults. Other faults (e.g. syntax) may occur and would go undetected unless checked via the STA opcode.

The STA opcode initiates the Model AT8000A to formulate its status message. Once formulated, only receipt of the instrument's GPIB talk address is necessary to start sending the status message. Upon completing the transfer, the Model AT8000A processor resets the status message to a single <space>. Should the remote controller ever receive a status message of just a single <space>, the instrument has no faults to report.

A status message reporting a fault is as follows:

F07DCS (<origin>): <text>

Where:

F07

Indicates a CIIL Fault type 07 involving syntax, a CNF/IST failure, or non-catastrophic hardware fault.

DCS

Direct Current Supply (Model AT8000A).

(<origin>)

Origin of the fault within the DCS. The origin would be MOD if detected by the internal control section of the instrument (e.g. communication fault, syntax, etc). The origin would be DEV if detected by a channel or Test Board. The parenthesis is part of the string.

<text>

Description of the fault.

The Model AT8000A supports the following fault messages via the STA opcode:

F07DCS (MOD): COMMAND ERROR
Values out of range.

F07DCS (MOD): SYNTAX ERROR
Programming error.

F07DCS (MOD): CHANNEL NOT INSTALLED
An attempt was made to program a channel that was not installed.

F07DCS (MOD): TEST BOARD FAILURE
Test Board failed.

F07DCS (DEV): CONFIDENCE FAILURE :CHxx
Channel xx failed CNF/IST.

F07DCS (DEV): MULTIPLE FAILURE
Multiple channels failed CNF/IST.

F07DCS (DEV): CURRENT LIMIT :CHxx
The output current on channel xx exceeded the programmed CURL value.

F07DCS (DEV): CROWBAR :CHxx
Channel xx activated its Crowbar, either due to overvoltage on the output or due to module failure.

F07DCS (DEV): OVER TEMPERATURE :CHxx
The module in channel xx exceeded the rated temperature.

3.7 IEEE-488 DEFINITIONS

The Model AT8000A implements the GPIB (General Purpose Interface Bus) for all remote programming and returned messages (GPIB and IEEE-488 are completely interchangeable terms). The Model AT8000A GPIB listen address is set on the rear of the master chassis via a 5-bit DIP switch as described in Section II. Programming of all instrument channels requires only the single GPIB address.

Mnemonics are implemented and behave as defined by the IEEE-488 standard. The Model AT8000A has no special nor unusual GPIB implementation requirements. The mnemonics listed in Table 3-3 below may change name from controller to controller.

Table 3-3. GPIB/Mnemonic Listing

GPIB	Mnemonic
ATN	Attention
DAB	Data Byte
DAC	Data Accepted
DAV	Data Valid
DCL	Device Clear
IFC	Interface Clear
MLA	My Listen Address
MTA	My Talk Address
REN	Remote Enable
RFD	Ready For Data
UNL	Unlisten
UNT	Untalk

3.7.1 CIIIL Implementation of the GPIB

CIIIL version technical implementation of the GPIB is:

Floating point decimal per IEEE 728-1982. Accepts signed NR1, NR2, and NR3. End of String: <CR><LF>.

The CIIIL version complies and conforms to IEEE 488-1978 Standard GPIB (General Purpose Interface Bus).

Implemented subsets of this standard are described in Table 3-4 below.

Table 3-4. CIIL Implemented Subsets on GPIB

Function	Subset	Definition
SH	SH1	Source handshake capability.
AH	AH1	Acceptor handshake capability.
T	T6	Talker (basic talker, serial poll, no talk only mode, unaddressed to talk if addressed to listen).
L	L4	Listener (basic listener, no listener only mode, unaddressed to listen if addressed to talk).
SR	SR0	No service request capability.
RL	RL1	Remote/local capability.
PP	PP0	No parallel poll capability.
DC	DC1	Device clear and selected device clear capability.
DT	DT0	No device trigger capability.
C	C0	No controller capability.

The Model AT8000A CIIL interface is defined as a listen and talk device with remote and local capability. Local lockout of the keyboard is automatic whenever the DCS is in the remote mode (RMT LED is illuminated). Both Device Clear and Selected Device Clear are implemented comparable to the remote RST opcode, but for all channels simultaneously.

3.7.2 ABLE Implementation of the GPIB

ABLE version technical implementation of the GPIB is:

Floating point decimal per IEEE 728-1982. Accepts signed NR1, NR2, and NR3.

Message separator:

SR1,

End of string:

<CR><LF>; <CR><LF> and EOI; or EOI alone.

The ABLE version complies and conforms to IEEE 488-1978 Standard GPIB (General Purpose Interface Bus).

Implementation subsets of this standard are described in Table 3-5.

To minimize undesired sense line pickup, sense line cables should use the cancelling effects of twisted pair wires.

Shielded twisted pairs are even better, if needed. Sense lines should be physically separated from high current output, ideally via a separate cable. Sense resistors, if used, should be connected as close as practical to the load. Observe the maximum remote sense voltage drop limit (refer to page A-3).

High frequency disturbances are usually minimized by prudent use of 0.01mfd to 1.0 μ fd bypass capacitors.

In high performance applications, as in motor start up and associated inrush/transient currents, extra consideration is required. The cable wire gauge must consider peak voltages and currents which may be up to ten times the average values. An underrated wire gauge adds losses which alter the inrush characteristics of the application and, thus, the expected performance.

The following table identifies popular ratings for DC and AC power source cable wire gauges.

Recommended Wire Gauge Selection Guide Table

Column 1	Column 2	Column 3	Column 4
Size (AWG)	Amperes (Maximum)	Ohms/100 Feet (One Way)	IR Drop/100 Feet* (Col. 2 X Col. 3)
18	5	0.473	2.363
16	7	0.374	2.621
14	15	0.233	3.489
12	20	0.147	2.940
10	30	0.095	2.859
8	40	0.053	2.136
6	55	0.033	1.837
4	70	0.021	1.477
2	95	0.013	1.273

* A maximum of 0.75V is allowable.

The following notes apply to the above table and to the power cable definition:

1. The above figures are based upon insulated copper conductors at 30°C (86°F), two current carrying conductors in the cable plus a safety ground (chassis) plus a shield.

Column 2 and Column 3 in the table above refer to the "one way" ohms and IR drop of current carrying conductors (e.g., a 50-foot cable contains 100 feet of current carrying conductors).

2. Determine which wire gauge to use for the application by knowing the expected peak load current (I_{peak}), the maximum tolerated voltage loss (V_{loss}) within the cable, and the one way cable length. The formula below determines which ohms/100 feet entry is required from Column 3. Read the corresponding wire gauge from Column 1.

$$(\text{Column 3 value}) = \frac{V_{loss}}{[I_{peak} \times 0.02 \times (\text{cable length})]}$$

Where:

Column 3 value = Entry of the table above

Cable length = One way cable length in feet.

V_{loss} = Maximum loss, in volts, permitted within cable.

Special case: Should the V_{loss} requirement be very loose, the peak may exceed the maximum amperes (Column 2). In this case, the correct wire gauge is selected directly from the first two columns of the table.

Example:

A 20 ampere (I_{peak}) circuit which may have a maximum 0.5 volt drop (V_{loss}) along its 15-foot cable (one way cable length) requires (by formula) a Column 3 resistance value of 0.083. This corresponds to wire gauge size 8 AWG.

If the cable length was 10 feet, the Column 3 value would be 0.125 and the corresponding wire gauge would be 10 AWG.

3. Aluminum wire is not recommended due to soft metal migration at the terminal which may cause long term (years) poor connections and oxidation. If used, increase the wire gauge by two sizes (e.g., specify 10 gauge aluminum instead of 14 gauge copper wire).

4. Derate the above wire gauge (use a heavier gauge) for higher environmental temperatures since conductor resistance increases with temperature.

Temperature in Degrees		Current Capability
C	F	
40	104	80%
50	122	50%

5. Derate the above wire gauge (go to a heavier gauge) for an increased number of current carrying conductors. This offsets the thermal rise of bundled conductors.

<u>Number of Conductors</u>	<u>Current Capability</u>
-----------------------------	---------------------------

3 to 6	80%
Above 6	70%

6. The preferred insulation material is application dependent. Elgar's recommendation is any flame retardant, heat resistant, moisture resistant thermoplastic insulation rated to a nominal 75°C (240°F). Voltage breakdown must exceed the combined effects of:
- The rated output voltage.
 - Transient voltages induced onto the conductors from any source.
 - The differential voltage to other nearby conductors.
 - Floating or series connections of supplies/ loads.
 - Safety margins to accommodate degradations due to age, mechanical abrasion and insulation migration caused by bending and temperature.

7. Sense lines are generally 24 to 18 (more mechanical strength) gauge wire, twisted pair, shielded, and have the same insulation rating and properties as its related current carrying conductors. Sense lines are physically separated (a separate cable) from current carrying conductors to minimize undesirable pickup.
8. As frequency increases, the magnetic field of the current carrying conductors becomes more significant in terms of adverse coupling to adjacent electrical circuits. The use of twisted pairs help cancel these effects. Shielded twisted pairs are even better. Avoid close coupling with nearby cables by using separate cable runs for high power and low power cables.
9. The above general values and recommendations should be reviewed, modified and amended, as necessary, for each application. Cables should be marked with appropriate safety WARNING decals if hazardous voltages may be present.

APPENDIX B

VERIFICATION CHECKSHEET

CONFIGURATION AND FUNCTIONAL VERIFICATION CHECKSHEET
ELGAR MODEL AT8000A PROGRAMMABLE DC POWER SYSTEM

Model Number: _____ Chassis S/N: _____

Equipment Property Number: _____

Part of Equipment: _____ Location: _____

Date: _____ Inspector: _____ Dept.: _____

AC Input Voltage 115: _____ 230: _____

Remote Language ABLE: _____ CIIL: _____

GPIB Address _____

Group Select Switch A _____ B _____ C _____

Display/Keyboard Installed Yes _____ No _____

Built In Test (BIT) Board Installed Yes _____ No _____

Output Connectors Terminal _____ MIL-SPEC _____

Auxiliary Drive Module Installed Yes _____ No _____

Electronic Load Module Installed Yes _____ No _____

CONFIDENCE TEST (CNF)

Channel Number	CNF Test	Load Relay	Max. Voltage	Prog. Voltage	Meas. Voltage	Polarity Relay	Max. Current	Current Limit	Remote Test