

A039

ELECTRONIC NAVIGATION INDUSTRIES, INC.

INSTRUCTION MANUAL

MODEL 2100L

BROADBAND POWER AMPLIFIER

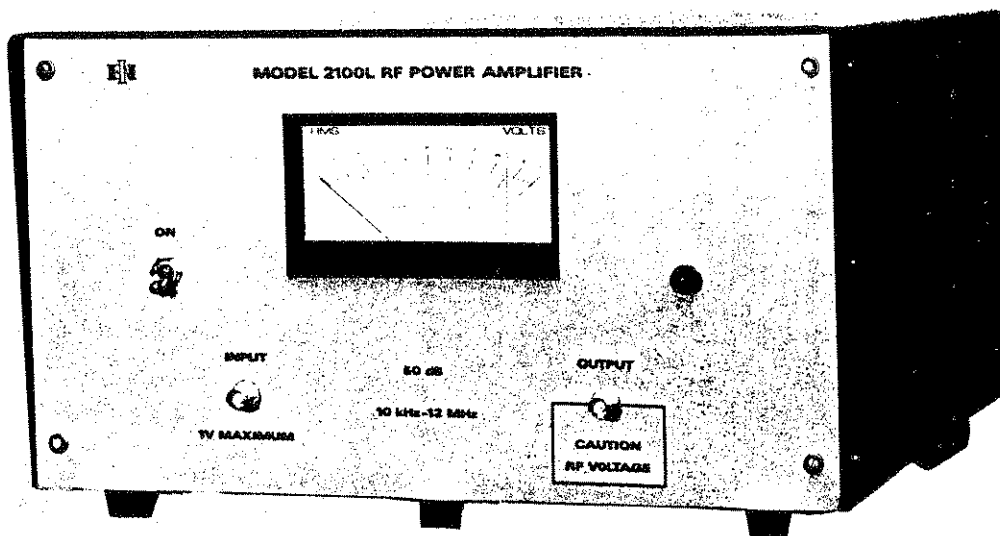

3000 Winton Road South, Rochester, New York 14623

Telephone: Area Code 716 473-6900

Telex #97-8283 ENI ROC

WARRANTY

Electronic Navigation Industries, Inc. warrants each instrument to be free from defects in material and workmanship. Our liability under this warranty is limited to servicing and replacing any defective parts for a period of one (1) year after delivery to the original purchaser.

When warranty service is required, the instrument must be returned transportation charges prepaid to the factory or our authorized service facility. If, in our opinion, the fault has been caused by misuse or abnormal conditions of operation, repairs will be billed at cost. In this case, an estimate will be submitted before work is started.

There are no other warranties expressed or implied, including any warranty of merchantability or fitness. Seller shall not be responsible for any incidental or consequential damages arising from any breach of warranty.

TABLE OF CONTENTS

CHAPTER 1	GENERAL INFORMATION	
	1.1	Introduction.....1
	1.2	Specifications.....1
	1.3	Instrument Identification.....1
CHAPTER 2	OPERATION	
	2.1	Introduction.....3
	2.2	Rack Installation.....3
	2.2.1	Mains Voltage Adjustment.....3
	2.2.2	Mains Fuse Rating.....3
	2.2.3	Mains Lead Connection.....3
	2.3	Operation.....3
CHAPTER 3	TECHNICAL DESCRIPTION	
	3.1	General Description.....4
CHAPTER 4	MAINTENANCE	
	4.1	Introduction.....5
	4.2	Access and Layout.....5
	4.3	Performance Check.....5
	4.3.1	Initial Check.....5
	4.4	Re-alignment Procedure.....5
	4.4.1	Measurement of Gain.....5
	4.4.2	Measurement of Harmonics.....7
	4.5	Packaging for Reshipment.....7
CHAPTER 5	SCHEMATIC AND PARTS LIST	
	5.1	Schematic Diagram.....8
	5.2	Parts List.....8
	5.3	List of Manufacturers.....8
	5.4	Ordering Replacement Parts.....8

CHAPTER 1 GENERAL INFORMATION

1 INTRODUCTION

Model 2100L is a broadband solid state amplifier covering the frequency range of kHz to 12 MHz.

More than 100 watts of RF power can be produced at the output, with low harmonic and intermodulation distortion. Up to 300 watts of saturated power can be produced with increased distortion products. A highly linear Class A design, the Model 2100L will amplify outputs of AM, FM, SSB, pulse and other complex modulations. The 50 dB gain of the unit is unconditionally stable and will not oscillate for any possible combination of source and load impedance. It is protected against failure due to output load mismatch and/or overdrive.

Output RF voltage level, as well as power put into 50 ohms, is monitored by a front panel meter. An integral power supply permits operation from 115/230 single phase power.

2 SPECIFICATIONS

Physical and electrical specifications are listed in Table 1-1.

1.3 INSTRUMENTATION IDENTIFICATION

Each amplifier is identified by a serial number tag on the back panel of the unit. Both the model number and the serial number should be given in any correspondence with the company.

Table 1-1. Specifications

FREQUENCY COVERAGE:	10 kHz to 12 MHz
GAIN:	50 dB, ± 1.5 variation
CLASS A LINEAR OUTPUT:	Nominal 100 watts
HARMONIC DISTORTION:	More than 25 dB below fundamental at 100 watts output.
SATURATED RF POWER OUTPUT:	Greater than 150 watts 10 kHz to 12 MHz Greater than 200 watts 30 kHz to 4 MHz
INPUT IMPEDANCE:	50 ohms, VSWR, 1.8 maximum
OUTPUT IMPEDANCE:	50 ohms, VSWR, 2.5 maximum
NOISE FIGURE:	9 dB typical
STABILITY:	Unconditionally stable
PROTECTION:	Unit will withstand more than 16 dB overdrive for all output load conditions.
OUTPUT METER:	Average reading voltmeter calibrated in RMS volts (0-100v) for a sine wave also calibrated in watts into 50 ohms (0-200W), $\pm 3\%$ of full scale accuracy
POWER REQUIREMENTS:	115 VAC $\pm 7\%$ at 9.5 Amperes 230 VAC $\pm 7\%$ at 5 Amperes
SIZE:	8 3/4 x 15 x 19 5/8 inches 22.2 x 38.1 x 49.9 cm
WEIGHT:	63.5 pounds 28.8 kg
CONNECTORS:	BNC
OPERATING TEMPERATURE:	0° to +45° C
RACK MOUNTING:	19 inch rack adaptors provided

1 INTRODUCTION

The ENI Model 2100L RF amplifier is used to increase the r.f. output level of signal sources in the 10 kHz to 12 MHz range. No tuning or any other form of adjustment is required other than the selection of the correct power supply input voltage.

The 2100L produces rated power output at its output connector, regardless of load impedance. Any power reflected due to input load mismatch is absorbed in the amplifier. Therefore, although the output impedance is 50 ohms (maximum VSWR:2.5:1), the amplifier will work into any load impedance.

2 RACK INSTALLATION

For standard nineteen inch relay rack installations, rack mounting brackets are supplied with the unit. Remove the three #10-32 screws on each side of the cover to release the front panel. Attach the rack mounting brackets firmly, using the hardware removed above. The rubber feet may be unscrewed and removed if the minimum vertical usage of the relay rack is necessary.

2.1 Mains Voltage Adjustment

The Model 2100L is normally factory set for 115 VAC operation.

To operate the unit on a 230 VAC line, perform the following steps:

- (i) Remove the front panel and locate terminal block TB1 on the baseplate.
- (ii) Remove the two jumper wires from terminals 1 through 4.
- (iii) Replace one jumper between terminals 2 and 3.
- (iv) Replace front panel.
- (v) Replace 12 ASB fuse (fuse holder located on rear panel) with 8 ASB type 3 AGC.

Failure to connect the jumpers to the correct terminals may result in severe damage to the unit.

2.2.2 Mains Fuse Rating

The mains fuse F1 is located on the rear panel. The replacement part number details are:

115 V	12 Amp	Slow Blow	ENI Part No. 313012
230 V	8 Amp	Slow Blow	ENI Part No. 313008

2.2.3 Mains Lead Connection

For 230 Va.c. operation, a suitable mains supply plug must be fitted to the mains lead attached to the instrument. The three conductors are color coded as follows:

BLACK	-	Live
WHITE	-	Neutral
GREEN	-	Earth

2.3 OPERATION

Determine and adjust the voltage setting and fuse rating as described in the previous sections 2.2.1 and 2.2.2 then proceed as follows:

- (i) Ensure input voltage is not excessive

The 1 V rms indicated maximum input voltage is 5 times the level of the input signal required to achieve maximum output. Input voltages in excess of 2 volts peak may permanently damage the instrument.

- (ii) Connect the input signal via a 50 ohm coaxial lead and BNC plug to the input connector.
- (iii) Connect the output via a 50 ohm coaxial lead and BNC plug to the load.

1 GENERAL DESCRIPTION

The ENI 2100L is designed to amplify signals 50 dB in the frequency band of 10 kHz to 10 MHz. The signal from the front panel BNC connector is fed via a length of 50 ohm coaxial cable into the input of the driver amplifier module (2100L-4912). The signal from the input of the driver is coupled through C1 and C2 to the base of Q1. The output signal at the collector of Q1 is coupled to the base of transistor Q2 through capacitors C4 and C5. The further amplified signal appearing at the collector of Q2 is coupled by capacitors C7 and C8 to transformer T1. The two outputs of T1 are opposite phase, equal amplitude signals that are fed to the inputs of T2 and T3, where impedance matching to the inputs of transistors Q3 and Q4 occurs. The amplified signals at the collectors of transistors Q3 and Q4 are coupled to T5 and T6 through capacitors C15 and C16. T5 and T6 match the impedance of the transistors to the inputs of T7 where the two opposite phase, equal amplitude signals are combined to produce the driver output signal at connector J3.

The driver output signal is fed through a length of coaxial cable to the input of the power amplifier module (2100L-4911). The signal applied at J4 is split into two equal phase and amplitude signals by T1. These signals are impedance matched by T2 and T3 to the inputs of T4 and T5 where two opposite phase, equal amplitude signals from each transformer are produced. T6, T7, T8, and T9 match the impedance of the inputs of transistors Q1 through Q4 to the outputs of T4 and T5. The amplified signals appearing at the collectors of Q1 through Q4 are capacitively coupled to T10, T11, T12 and T13 where impedance is matched to the inputs of T14 and T15. These two transformers combine the opposite phase, equal amplitude signals from their respective transistor pairs into two equal phase, equal amplitude signals that are impedance matched by T16 and T17 to the inputs of T20. The power amplifier output signal is presented at connector J5, and then fed into a length of 50 ohm coaxial cable to the RF voltmeter module at connector J6 (3100L-4206).

The signal at J6 is connected via a length of microstrip transmission line to the output BNC connector J7. Off this microstrip line resistors R1, R2, R3 and R4 make up a high impedance voltage divider. A fast switching hot carrier diode D1 rectifies the RF voltage from the divider. A wire gimmick compensates for the high frequency roll-off of the diode D1. Resistors R4, R5, R6 and capacitor C1 filter the rectified RF and convert it to DC which is fed to the front panel meter (M1).

The power supply unit provides a 36 VDC 15 ampere source, and also a 25.5 VDC 3 ampere source that are both current limited and short circuit protected. The 36 VDC source is regulated by series pass transistors Q1 to Q6 of the P.A. power supply module (2100L-4913), and integrated circuit regulator IC1 on the power supply regulator module (2100L-4915). Also located on the power supply regulator module is R8 which adjusts the supply to 36 volts. The 25.5 VDC source is regulated by series pass transistors Q1 and Q2 of the driver power supply module (2100L-4914), and integrated circuit regulator IC-2 located on the power supply regulator module (2100L-4915). R3 which adjusts the supply to 25.5 volts is also located on the power supply regulator module. The front panel light and RF voltmeter are connected to the 25.5 volt source.

4.1 INTRODUCTION

The ENI 2100L RF amplifier requires no periodic maintenance. The instrument is unconditionally stable and is failsafe under all load conditions. Damage can only be externally caused by the incorrect selection of the AC supply voltage or by an input signal in excess of the specified 1 volt rms maximum.

This chapter therefore, deals only with certain fundamental procedures for fault location and with the subsequent re-alignment procedures.

Performance limits quoted are for guidance only and should not be taken for guaranteed performance specifications unless they are also quoted in the Specification Section 1.2.

4.2 ACCESS AND LAYOUT

The ENI 2100L RF amplifier is housed in an aluminum chassis. The cover can be removed by releasing the twelve #8-32 screws and the four #6-32 screws on the side of the unit and lifting by the handles.

4.3 PERFORMANCE CHECKS

To determine the amplifier's performance carry out the following procedure.

4.3.1 Initial Check

The following check can be made after repair and adjustments or whenever the condition of the unit is in question.

- i) Connect AC power supply. Switch on power and observe that the supply lamp (DS1) illuminates.
- ii) Connect a sweep generator (HP 8601 or similar) capable of sweeping the frequency range 10 kHz to 12 MHz to the input connector.
- iii) Adjust the output level of the sweep generator so that a 50 ohm video detector connected at the output of the unit will not be damaged by excessive power output.
- iv) Observe the gain versus frequency ripple on an oscilloscope calibrated in decibels. The gain variation must be not more than ± 1.5 dB over the frequency range.

- (v) Connect a calorimetric power meter (HP434 or equivalent) through a 10 dB 200 watt attenuator to the output connector. Adjust the input CW signal to any frequency between 10 kHz and 12 MHz for 100 watts output.

- (vi) Observe the harmonic distortion of the output on a spectrum analyzer. The harmonic components contributed by the amplifier should be better than 25 dB down from the fundamental.

If the requirements of this check are not met, verify that:

- (a) The mains AC supply voltage adjustment and fuse are correctly selected and that DS1 is illuminated.
- (b) The Power Amplifier power supply voltage is set at 36 volts by R8 and the driver amplifier power supply voltage is set at 25.5 volts by R3.

If the above checks are found to be correct, then normal fault location procedures, with reference to the circuit diagram Figure 5.1 should be followed to determine the correct operation of the driver/amplifier and power amplifier modules.

4.4 RE-ALIGNMENT PROCEDURE

Before any adjustment is made to the unit, first

- (i) Ensure that the mains voltage and fuse are correctly selected and that DS is illuminated.
- (ii) Measure the power supply voltages and adjust per section 4.3.1 (b).

4.4.1 Measurement of Gain

1.) Equipment Required (or equivalent):

- a) Oscilloscope - Tektronix T921
- b) Sweep/Signal Generator - HP8601A
- c) Signal Generator - Exact Model 7060
- d) 50 ohm Detector - Wavetek D151
- e) Attenuator, 10 dB, 75 Watts Emco A8610N
- f) Attenuator, 20 dB, 500 Watts, Electro Impulse AX-500-20

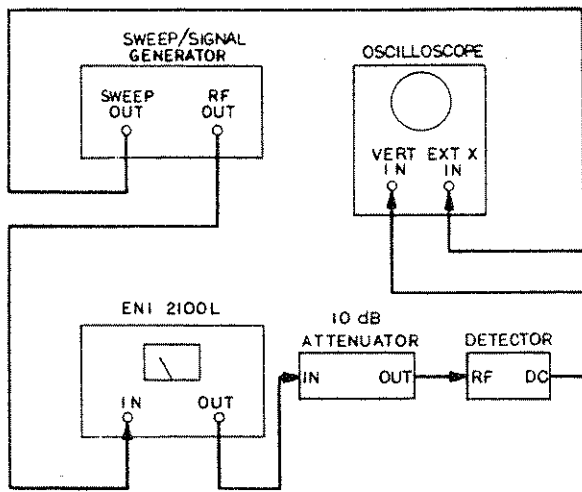

Figure 4-1. Gain Measurement

- 1) Connect the equipment as shown in Figure 4-1, then proceed as follows:

Set the oscilloscope to DC, Time/CM to Ext. X, and gain to 10MV/CM.

Set the sweep generator to the video sweep mode with the start frequency at 100 kHz and the sweep width to 12 MHz.

Disconnect the Model 2100L from the set-up and connect the sweep/generator RF output directly to the 10 dB attenuator.

Adjust the output level of the sweep/generator for full vertical deflection on the oscilloscope face.

Calibrate the scope face to show 3 dB in 1 dB steps by attenuating the sweep/generator in 1 dB steps and marking the traces with a grease pencil.

Return sweep/generator output level to full deflection. Rotate the step attenuator (CCW) so that the output is reduced by 50 dB.

Reconnect the 2100L into the test set-up of Figure 4-1.

Place the 2100L power switch to the "ON" position.

- i) Observe the gain versus frequency sweep on the oscilloscope.

- 1) The average gain should be 50 dB (within 1 dB)
- 2) The gain variation should be within the 3 dB markings as shown on the oscilloscope.

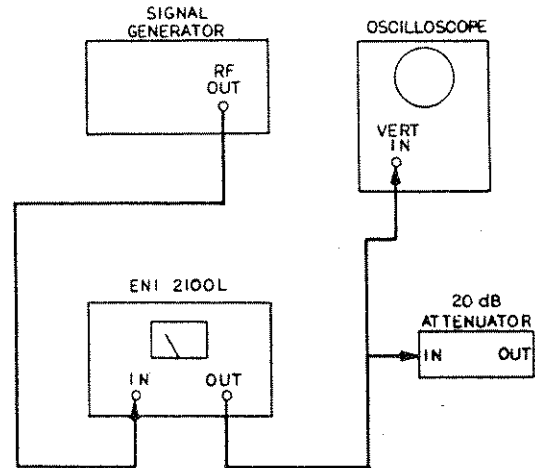

Figure 4-2.

- 3.) Reconnect the equipment as shown in Figure 4-2, then proceed as follows:
 - a) Set the oscilloscope to AC, Time/CM to 20 usec, and vertical gain to 2V/CM.
 - b) Adjust the signal generator frequency to 10 kHz sine wave and attenuate the generator output level by 30 dB.
 - c) Place the 2100L power switch to the "ON" position.
 - d) Adjust the generator output level so that a 16V peak to peak sine wave is observed on the oscilloscope face.
 - e) Increase the frequency in 10 kHz steps up to 100 kHz while observing the sine wave. It should not drop below 14.25 V peak to peak. (1 dB Loss)

4.2 Measurement of Harmonics

Equipment Required:

Sweep/Signal Generator HP8601A
Signal Generator Exact Model 7060
Calorimetric Power Meter HP434A
Spectrum Analyzer HP140T Display Unit
HP8554L Spectrum Analyzer
RF Section
HP8552A Spectrum Analyzer
IF Section

Attenuator, 20 dB, Electro Impulse
AX-500-20

Attenuator, 30 dB, Bird 8321

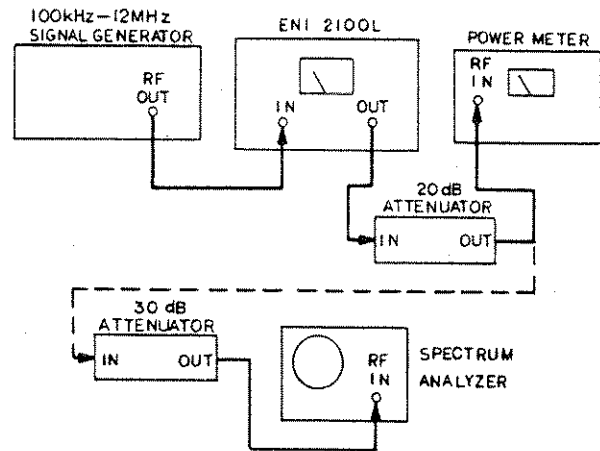

Figure 4-4.

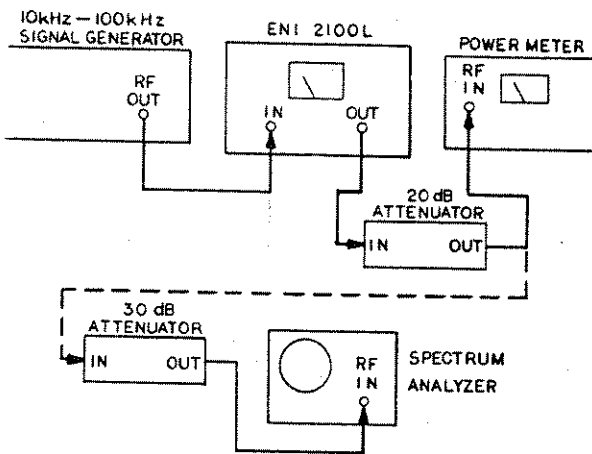

Figure 4-3.

- Connect the Equipment as shown in Figure 4-3, then proceed as follows:

Adjust the signal generator to a CW center frequency of 10 kHz, for an indicated output of 100 watts on the power meter.

Using the spectrum analyzer, check that the level of the carrier harmonics is less than -25 dB with respect to the carrier while manually scanning the frequency band of 10 kHz to 100 kHz. An indicated power output of 100W should be maintained during this operation.

- Reconnect the equipment as shown in Figure 4-4, then proceed as follows:

- Adjust the sweep/signal generator to a CW center frequency of 100 kHz for an indicated output of 100W on the power meter.
- Using the spectrum analyzer, check that the level of the carrier harmonics is less than -25 dB with respect to the carrier while manually scanning the frequency band of 100 kHz to 12 MHz. An indicated power output of 100W should be maintained during this operation.

4.5 PACKAGING FOR RESHIPMENT

In the event of the equipment being returned for servicing it should be packed in the original shipping carton and packing material. If this is not available, wrap the instrument in heavy paper or plastic and place in a rigid outer box of wood, fiberboard or very strong corrugated cardboard. Use ample soft packing to prevent movement. Provide additional support for projecting parts to relieve these of unnecessary shock. Close the carton securely and seal with durable tape. Mark the shipping container FRAGILE to ensure careful handling.

CHAPTER 5 SCHEMATIC AND PARTS LIST

.1 SCHEMATIC DIAGRAM

A complete schematic diagram appears in figure 5-1.

.2 PARTS LISTS

Table 5-1 provides a listing of all electrical parts and those mechanical parts which may be required for replacement. Electrical parts are listed by module number and by reference designations as indicated on the schematic diagram. Parts list includes a description, part number and manufacturer's federal supply code number. Table 5-2 provides a reference glossary of abbreviations used in the parts list.

.3 LIST OF MANUFACTURERS

Table 5-3 provides a correlation of the manufacturer's federal supply code numbers used in the parts list with the names and addresses of the manufacturers. If ENI's manufacturer code number (10226) appears, that part must be obtained directly from Electronic Navigation Industries, Inc.

.4 ORDERING REPLACEMENT PARTS

To obtain replacement parts, address order or inquiry to Electronic Navigation Industries, Inc. or its authorized service facility. Identify parts by number as listed in the parts list.

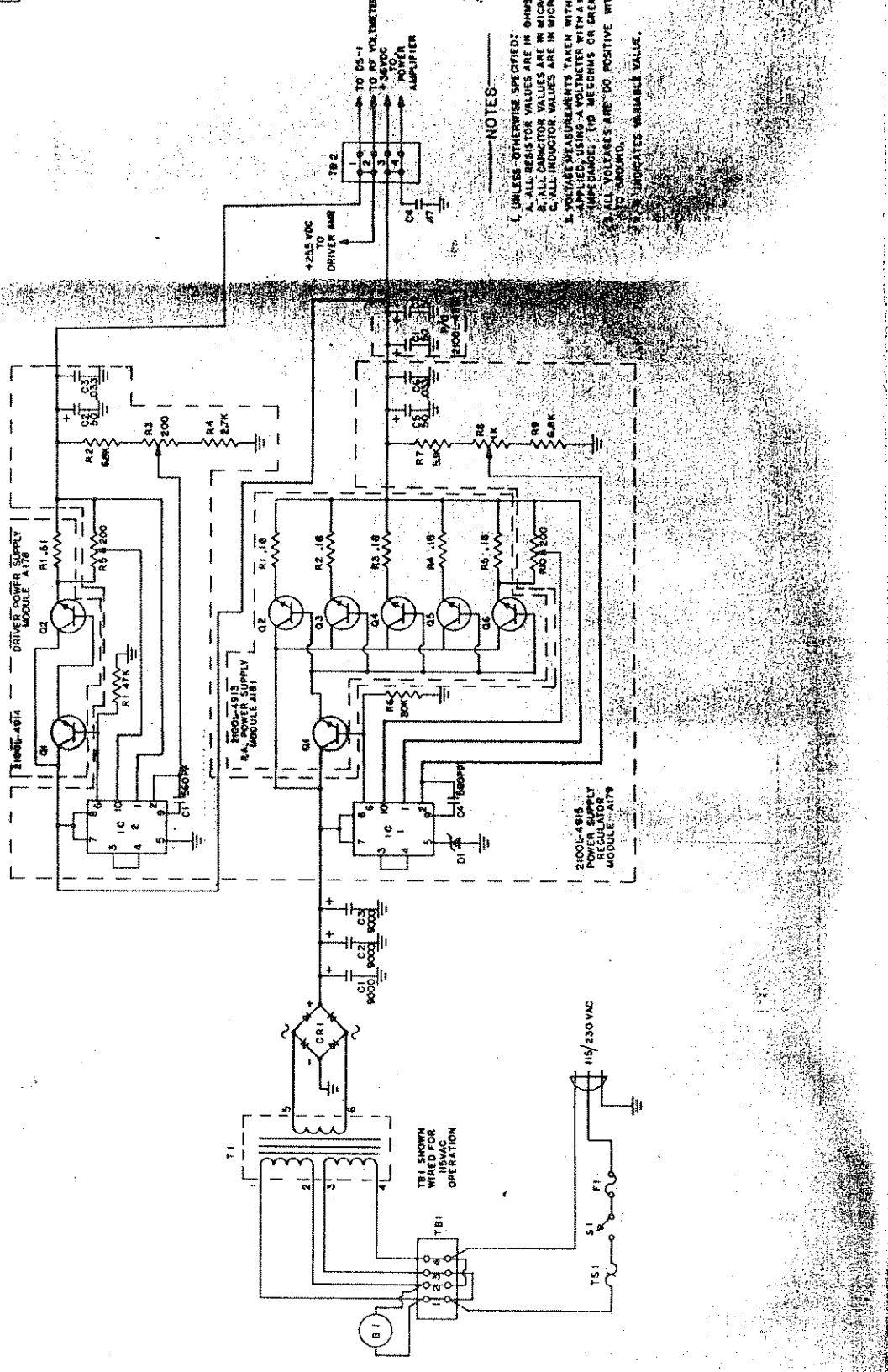
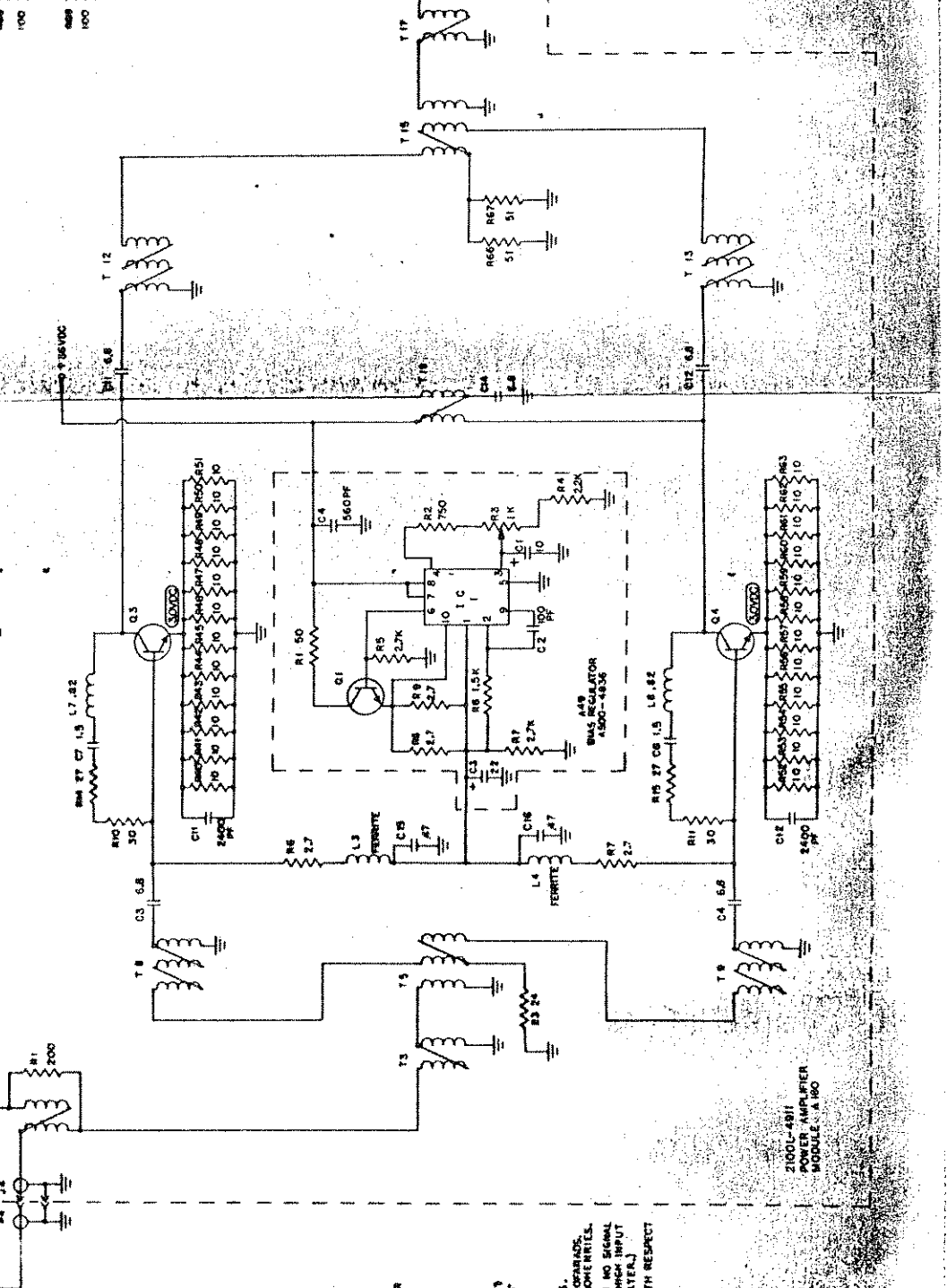
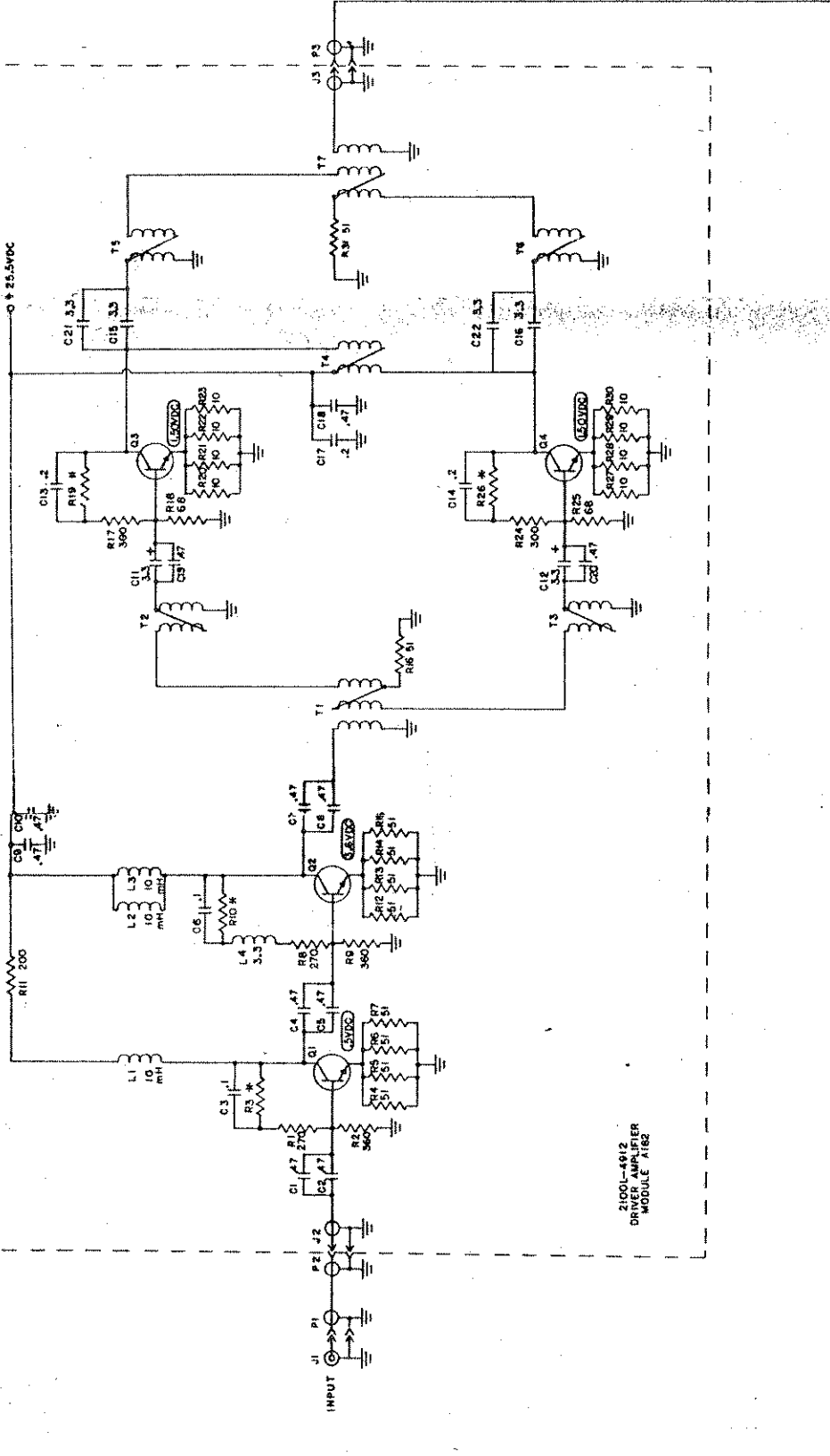
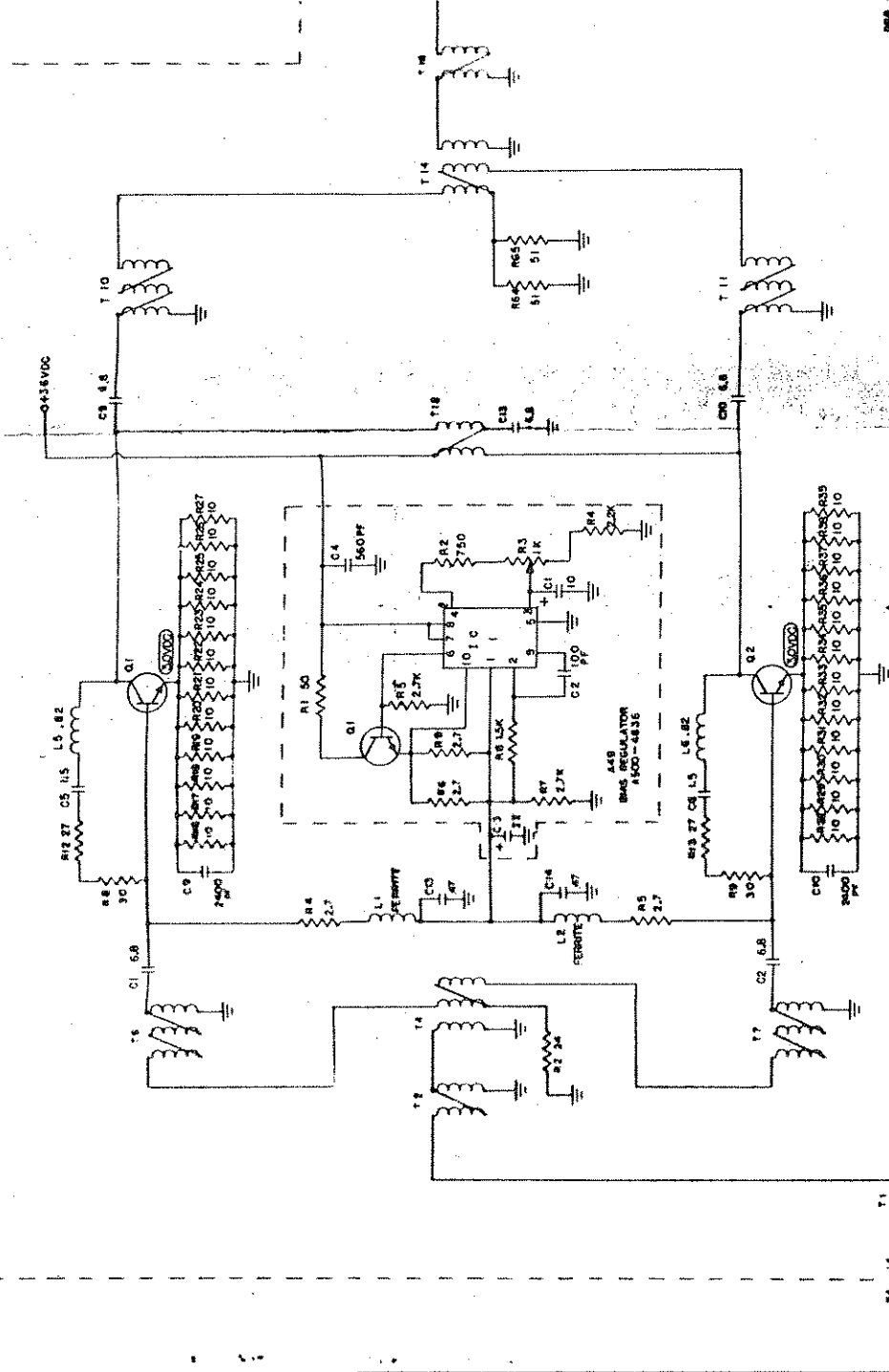

NOTES
 1. UNLESS OTHERWISE SPECIFIED:
 A. ALL RESISTOR VALUES ARE IN OHMS.
 B. ALL INDUCTOR VALUES ARE IN MICROMHMS.
 C. ALL CAPACITOR VALUES ARE IN PICO FARADS.
 2. ALL VALUES TAKEN WITH NO SIGNAL.
 3. ALL VOLTAGES ARE POSITIVE UNLESS OTHERWISE INDICATED.
 4. ALL VOLTAGES ARE TO MESH OR GATE.
 5. ALL VOLTAGES ARE TO POSITIVE WITH RESPECT TO GROUND.
 6. 'X' INDICATES VARIABLE VALUE.

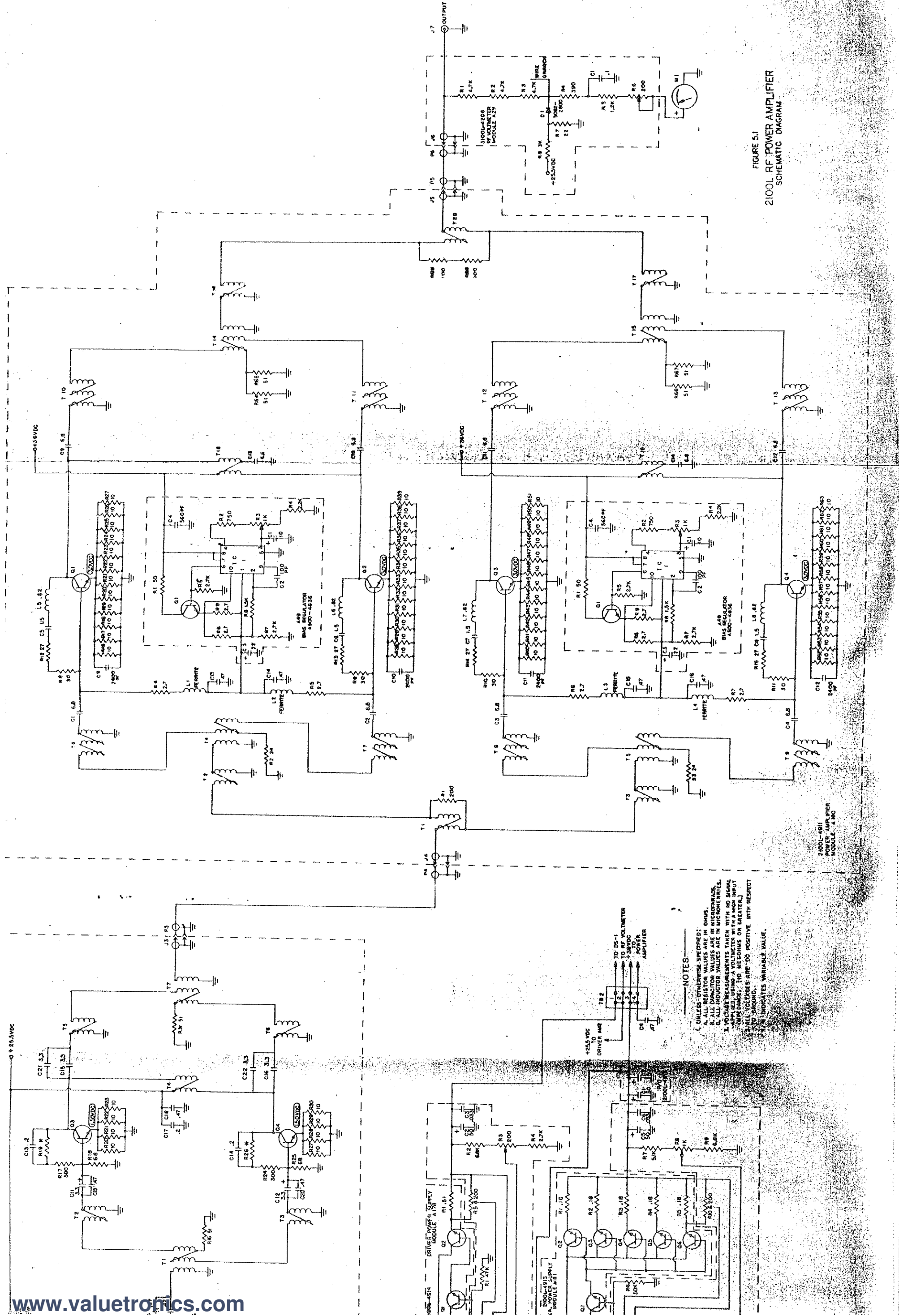

FIGURE 5.1
2100L RF POWER AMPLIFIER
SCHEMATIC DIAGRAM

NOTES
 1. UNLESS OTHERWISE SPECIFIED:
 A. ALL RESISTOR VALUES ARE IN OHMS.
 B. ALL CAPACITOR VALUES ARE IN MICROFARADS.
 C. ALL INDUCTOR VALUES ARE IN MICRORHENRIS.
 2. VOLTAGE MEASUREMENTS TAKEN WITH NO SIGNAL APPLIED, USING A VOLTMETER WITH A HIGH INPUT IMPEDANCE. (NO MEGOHMS OR GREATER.)
 3. ALL VOLTAGES ARE DC POSITIVE WITH RESPECT TO GROUND.
 4. 'X' INDICATES VARIABLE VALUE.

TABLE 5-1. REPLACEMENT PARTS LIST

REF. DESIGN	DESCRIPTION	MFR CODE	PART NO.
	Power Distribution Assembly	10226	2100L-2911
TI	Transformer, Power	12715	AM9629A
CR1	Bridge, Full Wave	04713	MDA-3501
C1-C3	Capacitor, 9000uf 50 VDCW	56289	36D902G050BC2A
B1	Fan	28875	120VZ282115V
FX	Fuseholder	75915	342001
F1	Fuse Type 3AGC 12 ASB	75915	313012
DS1	Pilot Lamp 28 VDC	71744	327
M1	Meter & Mounting Kit	32171	840-586
S1	Switch, SPST	27191	7361K5
	Power Supply Heatsink Assembly	10226	2100L-3916
A181	Power Amplifier Power Supply Board	10226	2100L-4913
A181R1-R5	Resistor .18 ohm 5W 10%	75042	PW-5
A181C1,C2	Capacitor 50uf 50 VDCW	56289	500D506G050DD7
A181Q1	Transistor	10226	40312
A181Q2-Q6	Transistor	10226	ENI-1
A178	Driver Amplifier Power Supply Board	10226	2100L-4914
A178R1	Resistor .51 ohm 2W 5%	75042	BWH.51
A178Q1	Transistor	10226	40312
A178Q2	Transistor	10226	ENI-1
A179	Power Supply Regulator Board	10226	2100L-4915
A179R1	Res. Carb.Film 47K ohm 1/4W 5%	09021	
A179R6	Res. Carb.Film 30K ohm 1/4W 5%	09021	
A179R2,R9	Res. 6.8K ohm 1/2W 5%	16299	HC-5
A179R7	Res. 5.1K ohm 1/2W 5%	16299	HC-5
A179R4	Res. 2.7K ohm 1/2W 5%	16299	HC-5
A179R8	Potentiometer 1K ohm	32997	3386T-1-102
A179R3,R5,R10	Potentiometer 200 ohm	32997	3386T-1-201
A179C3,C6	Capacitor .033uf 50 VDCW	36346	C320C333M5U5
A179C1,C4	Capacitor 560pf	09023	CM06FD561J03
A179C2,C5	Capacitor 50uf 50VDCW	56289	500D506G050DD7
A179IC1,IC2	Integrated Circuit Regulator	49956	RC723T
A179D1	Diode, Zener	80795	1N759A
	Power Amplifier Heatsink Assembly	10226	2100L-3914
A180	Power Amplifier Board	10226	2100L-4911
A180R1	Res. Met. Oxide 200 ohm 2W 5%	09021	MO-2
A180R2,R3	Res. Met. Oxide 24 ohm 1W 5%	09021	MO-1
A180R4-R7	Res. Carb.Film 2.7ohm 1/4W 5%	09021	CR-5
A180R8-R11	Res. Met. Oxide 30 ohm 3W 5%	09021	MO-3
A180R12-R15	Res. Met. Oxide 27 ohm 3W 5%	09021	MO-3
A180R16-R63	Res. Met. Oxide 10 ohm 3W 5%	09021	MO-3
A180R64-R67	Res. Met. Oxide 51 ohm 2W 5%	09021	MO-2
A180C1-C4,C9-C14	Capacitor 6.8uf 100V	36346	C350C685M5RCA
A180C5-C8	Capacitor 1.5uf 100V	36346	C350C155M5R5CA
A180C13-C16	Capacitor .47uf 50V	36346	C330C474M5U1CA
A180C9-C12	Capacitor 2400pf	09023	CM06FD242J03

TABLE 5-1. REPLACEMENT PARTS LIST (Cont)

REF. DESIGN	DESCRIPTION	MFR CODE	PART NO.
A180L1-L4	Choke, Ferrite	10226	1537-10
A180L5-L8	Choke, .82 uhy	99880	
A180T1	Transformer	10226	
A180T2,T3	Transformer	10226	
A180T4,T5	Transformer	10226	
A180T6-T9	Transformer	10226	
A180T10-T13	Transformer	10226	
A180T14,T15	Transformer	10226	
A180T16,T17	Transformer	10226	
A180T18,T19	Transformer	10226	
A180T20	Transformer	10226	
A180Q1-Q4	Transistor	10226	ENI-20
A49	Bias Regulator Board	10226	A500-4836
A49R6	Res. Carb. Film 2.7 ohm 5% 1/4W	09021	CR-5
A49R2	Res. Carb. Film 750 ohm 5% 1/4W	09021	CR-5
A49R8	Res. Carb. Film 1.5K ohm 5% 1/4W	09021	CR-5
A49R4	Res. Carb. Film 2.2K ohm 5% 1/4W	09021	CR-5
A49R5,R7	Res. Carb. Film 2.7K ohm 5% 1/4W	09021	CR-5
A49R3	Potentiometer 1K ohm	32997	3396T-1-102
A49C1	Cap. Tantalum 10uf 10VDCW	36346	T390B106K010AS
A49C2	Cap. Mica 100pf 5%	09023	OM05ED101J03
A49C3	Cap. Tantalum 22uf 10VDCW	36346	T390C226K010AS
A49C4	Cap. Mica 560pf 5%	09023	OM05ED561J03
A49IC1	I.C. Regulator	49956	RC723CT
A49Q1	Transistor	79089	40312
TS1	Thermal Switch	14604	3450-088-175
	Driver Amplifier Heatsink Assembly	10226	2100L-3915
A182	Driver Amplifier Board	10226	2100L-4912
A182R1	Res. Carb. Film 270 ohm 5% 1/4W	09021	CR-5
A182R2,R9	Res. Carb. Film 360 ohm 5% 1/4W	09021	CR-5
A182R3,R10	Resistor, Variable Value	09021	
A182R4-R7	Res. Carb. Film 51ohm 5% 1/4W	09021	CR-5
A182R11	Res. Metal Oxide 200 ohm 5% 2W	09021	MO-2
A182R12-R16	Res. Carb. Film 51 ohm 5% 1/2W	09021	CR-5
A182R17,R24	Res. Metal Oxide 300 ohm 5% 2W	09021	MO-2
A182R18,R25	Res. Carb. Film 68 ohm 5% 1/2W	09021	CR-5
A182R19,R26	Resistor Variable Value	09021	
A182R20-R27-R30	Res. Metal Oxide 10 ohm 5% 1W	09021	MO-1
A182R31	Res. Metal Oxide 51 ohm 5% 2W	09021	MO-2
A182C1,2,4,5,7,8 18-20	Capacitor .47 uf 50V	36346	C330C474M5U1CA
A182C3,C6	Capacitor .1uf 50V	36346	C330C104M5U5
A182C13,C14,C17	Capacitor .22uf 50V	36346	C330C224M5U1CA
A182C11,C12	Capacitor 3.3uf	36346	TK2-035-335-20
A182C15,C16	Capacitor 6.8uf	36346	C350C685M5R5CA
A182L1-L3	Choke 10 uhy	42498	R40-10
A182L4	Choke 3.3 uhy	99880	1537-24
A182T1	Transformer	10226	
A182T2,T3	Transformer	10226	
A182T5,T6	Transformer	10226	
A182T4	Transformer	10226	
A182R8	Res. Carb. Film 270 ohm 5% 2W	09021	MO-2

TABLE 5-1. REPLACEMENT PARTS LIST (Cont)

REF. DESIGN	DESCRIPTION	MFR CODE	PART NO.
A182T7	Transformer	10226	
A182Q1	Transistor	10226	CD2240
A182Q2-Q4	Transistor	10226	ENI-16
A29	RF Voltmeter Board	10226	3100L-4206
A29R8	Res. Carb.Film 22 ohm 5% 1/4W	09021	CR-5
A29R4	Res.Carb. Film 390 ohm 5% 1/4W	09021	CR-5
A29R7	Res. Carb.Film 3K ohm 5% 1/4W	09021	CR-5
A29R1-R3	Res. Carb.Film 4.7K ohm 5% 1/2W	09021	CR-5
A29R5	Res. Carb.Film 1.2K ohm 5% 1/4W	09021	CR-5
A29R6	Potentiometer 200 ohm	32997	3386T-1-201
A29C1	Capacitor .1 uf 50V	36346	C330C104M5U5
A29D1	Diode	28480	HPA-5082-2800

TABLE 5-2. GLOSSARY OF ABBREVIATIONS

AMP	AMPERES	PF	PICOFARA
AMPL	AMPLIFIER	POT	POTENTIOMETER
BKT	BRACKET	REF	REFERENCE
CAP	CAPACITOR	RES	RESISTOR
CER	CERAMIC	SIL	SILICON
COMP	COMPOSITION CARBON	UF	MICROFARADS
DPDT	DOUGLE-POLE,DOUBLE THROW	UH	MICROHENRY
ELECT	ELECTROLYTIC	V	VOLTS
IN	INCHES	VAR	VARIABLE
K	KILOHMS	VDCW	DC WORKING VOLTS
MTG	MOUNTING	W	WATTS
MW	MILLIWATTS	WW	WIRE WOUND

TABLE 5-3. LIST OF MANUFACTURERS

FEDERAL SUPPLY CODE NUMBER	MANUFACTURER	ADDRESS
04713	Motorola, Inc.	Phoenix, AZ
09021	Airco Speer Electronic Components	Bradford, PA
09023	Cornell-Dubilier Electronics	Sanford, NC
10226	Electronic Navigation Industries, Inc.	Rochester, NY
12715	American Magnetics Corporation	Carterville, IL
14604	Elmwood Sensors, Inc.	Cranton, RI
16299	Corning Glass	Raleigh, NC
27191	Cutler-Hammer Co.	Milwaukee, WI
28480	Hewlett-Packard	Palo Alto, CA
28875	IMC Magnetics Corp.	Rochester, NH
32171	Modutec, Inc.	Norwalk, CT
32997	Bourns, Inc.	Riverside, CA
36346	Union Carbide (Kemet)	New York, NY
42498	National Radio Co., Inc.	Melrose, MA
49956	Raytheon Co.	Lexington, MA
56289	Sprague Electric Co.	N. Adams, MA
71744	Chicago Miniature Lamp Works	Chicago, IL
75042	I.R.C. Div. of TRW, Inc.	Philadelphia, PA
75915	Littelfuse, Inc.	Des Plaines, IL
79089	R.C.A.	Harrison, NY
80795	I.T.T.	New York, NY
99880	Delevan Electronics, Inc.	East Aurora, NY