

OPERATORS' MANUAL

PROGRAMMABLE DC VOLTAGE CURRENT CALIBRATOR

Model 520A SERIES

Serial No. _____



ELECTRONIC
DEVELOPMENT
CORPORATION

BOSTON MASS
MADE IN U.S.A.

WARRANTY

The ELECTRONIC DEVELOPMENT CORPORATION (EDC) warrants to the original purchaser each instrument manufactured by them to be free from defects in material and workmanship. This warranty is limited to servicing, repairing and/or replacing any instrument or part thereof returned to the EDC factory for that purpose in accordance with the instructions set forth below; and furthermore to repair or replace all materials, except tubes, fuses, transistors and other semi-conductor devices which shall within one year of shipment to the original purchaser be returned to the EDC factory and upon examination be deemed defective.

EDC instruments may not be returned to the factory under the terms of this warranty without the prior authorization of the EDC Service Department. All instruments returned to EDC for service hereunder should be carefully packed and shipped. All transportation charges shall be paid by the purchaser.

EDC reserves the right to discontinue instruments without notice and to make changes to any instrument at any time without incurring any obligation to so modify instruments previously sold.

This warranty is expressly in lieu of all other obligations or liabilities on the part of EDC. No other person or persons is authorized to assume in the behalf of EDC any liability in the connection with the sale of its instruments.

CAUTION: The instrument you have purchased is a precision instrument manufactured under exacting standards. Any attempts to repair, modify or otherwise tamper with the instrument by anyone other than an EDC employee or authorized representative may result in this warranty becoming void.

FACTORY SERVICE REQUEST
and
AUTHORIZATION

WARRANTY SERVICE

Instruments may be returned only on prior authorization. Please obtain a RETURN AUTHORIZATION NUMBER either directly from the factory or from an authorized E.D.C. Representative. (See General Instructions below.)

CHARGEABLE REPAIRS

If requested, an estimate of charges will be submitted prior to repairs. We suggest that you request a RETURN AUTHORIZATION NUMBER to facilitate handling.

GENERAL INFORMATION

- A) Please provide the following information in order to expedite the repair:
 - 1) Indicate MODEL
 - 2) Serial Number
 - 3) Complete description of the trouble:
Symptoms, measurements taken, equipment used, lash-up procedures, attempted repairs, suspected location of failure and any other pertinent information.

- B) Freight Charges must be prepaid.

- C) The RETURN AUTHORIZATION NUMBER should be noted on your documentation.

LIST OF DRAWINGS
for
MODEL 520A

DESCRIPTION	DRAWING
Block Diagram	B-3753
MPU Flow Chart	M-4028
520A Control Board	B-3871
MPU	B-3998
MPU I/O	B-3981B
MPU IEEE-488 Logic	B-4043
DAC	B-3919A
Output Amplifier	B-3808D
Output Switching	B-3809
Range Logic	B-3992B
Power Supply	B-3632D
Adjustments & Test Points	B-3893
MPU & MPU I/O Layout	B-4063

520A MANUAL
(Series)

TABLE OF CONTENTS

I DESCRIPTION AND SPECIFICATIONS

- 1.1.0 General Description
- 1.2.0 Features and Applications
- 1.3.0 Output Specifications
- 1.4.0 General Specifications
- 1.5.0 Mechanical Specifications
- 1.6.0 General Information

II INSTALLATION

- 2.1.0 Mounting
- 2.2.0 Mating Connectors
- 2.3.0 IEEE 488 Cables
- 2.4.0 AC Power Input Considerations
- 2.5.0 Thermal Considerations

III OPERATION OF THE INSTRUMENT

- 3.1.0 Front Panel Controls
- 3.2.0 Front Panel Indicators
- 3.3.0 Output Connections
- 3.4.0 Remote Programming with the IEEE 488 Bus
- 3.5.0 Voltage Compliance Limit Control

IV THEORY OF OPERATION

- 4.1.0 Introduction
- 4.2.0 Control Board
- 4.3.0 Digital Board Control Logic
- 4.4.0 Digital Board IEEE 488 Logic
- 4.5.0 Digital to Analog Converter
- 4.6.0 Output Amplifier
- 4.7.0 Output Switching
- 4.8.0 Range Logic

V CERTIFICATION AND TESTING

- 5.1.0 Recommended Equipment
- 5.2.0 Calibration Procedure

VI

OPTIONS, ACCESSORIES, AUXILIARY INSTRUMENTS AND SUPPLEMENTAL
INSTRUCTIONS

- 6.0.0 Description and Specifications
- 6.1.0 General Description
- 6.2.0 Electrical Specifications
- 6.3.0 Calibration

SECTION I

1.0.0 DESCRIPTION AND SPECIFICATIONS

1.1.0 General Description

1.1.1 The EDC Model 520A is a microprocessor controlled enhanced version of the field proven Model 520. An industry standard 6500 series microprocessor has been incorporated to improve the reliability, and versatility of the instrument.

1.1.2 The Model 520A Programmable DC Voltage Standard is a highly versatile reference source, designed to meet the needs of computer systems, production line testing, automated calibration, and standards laboratories.

1.1.3 The instruments have a specified accuracy, and are traceable through a bank of saturated standard cells to the National Bureau of Standards.

1.1.4 Resolution of each range, in each function, is 1 part per million.

1.1.5 The instruments are highly accurate references which can be used for calibration of digital voltmeters, analog meters, semiconductor analyzing systems, analog references for computers, analog-to-digital converters, telemetry and data acquisition systems, and wherever a stable source is required.

1.1.6 The variable, constant current mode is designed for use in calibration and simulation of strain gages and other transducers.

1.1.7 There are no adjustments made during normal operation; the trims are made during calibration and are made during calibration and are described in the calibration procedure.

1.1.8 The circuitry is completely solid state made of discrete, hybrid and/or integrated circuits packaged on etched glass circuit boards. These are proven circuits, using derated components to insure long life and maximum reliability.

1.1.9 The instrument is overload and short-circuit proof, and is fully operational in normal environmental conditions.

1.1.10 The Standard Source will drive a short circuit indefinitely without damage to the instrument, and will recover to rated specifications in less than 100us.

1.2.0 Features and Applications

1.2.1 Features

Accuracies based on one full year calibration cycle and conservatively specified by using the "Limit of Error" (or Worst - Case) methods.

E Mode: $\pm(0.002\%$ of setting + 0.0005% of range)
I Mode: $\pm(0.005\%$ of setting + 1 μA)

Programming: IEEE-488 (GP-IB) and local/manual control.
(Note: Operator has control of local/remote mode i.e., shutdown not required to re-establish "local" control.)

3 Voltage ranges (1 ppm resolution or 6 decades)

± 100 Vdc resolved to 100 μV
 ± 10 Vdc resolved to 10 μA
 ± 100 mVdc resolved to 0.1 μV

2 Current ranges (1 ppm resolution or 6 decades)

± 100 mAdc resolved to 0.1 μA
 ± 10 mAdc resolved to 0.1 μA

(Note: 100 Vdc Compliance with variable control.)

Floating output. Optically isolated between analog output and digital input lines.

True bipolar control with balance zero.

Magnitude is maintained during polarity changes, and scaled on function changes and range changes in the manual mode. i.e., this eliminates the requirement of reentering the magnitude.

A "crowbar", or short circuit, of the output may be selected.

1.2.2 Applications

Calibration of DVMS, DMM, meters, chart recorders, A/D converters, ATE, monitors, controllers, logging systems, etc.

Simulation of thermocouples, and strain gages. (4 to 20 mA and 10 to 50 mA) and other transducers. NOTE: Compliance voltage from 1V to 100 Vdc.

Lower compliance limits are selectable.

Linearity check of amplifiers and function modules.

1.3.0 Output Specifications

1.3.1 Voltage Mode

Range	100 mVdc	10 Vdc	100 Vdc
Full Scale	$\pm 111.111 \text{ } \emptyset \text{ mVdc}$	$\pm 11.111 \text{ } 10 \text{ Vdc}$	$\pm 111.111 \text{ } \emptyset \text{ Vdc}$
Resolution (1 ppm)	100 nV	10 uV	100 uV
Compliance Current	EMF into 1 meg Ohms	100 mA	100 mA
Output Impedance	20 Ohms	10 mOhms	10 mOhms

Accuracy (Basis for accuracy statement):

The Accuracy Statement is based on the "Limit of Error" (or "worst case") method. All other specifications noted hereafter, which effect accuracy, e.g., line load temperature, and drift changes are included in the accuracy statement. Thus, all other specifications are listed as *non-Additive.

$$\pm(0.002\% \text{ of setting} + 0.0005\% \text{ of range} + 3 \text{ uV})$$

Note: The "+ 3 uV" specified above applies primarily to the 100 mV range where measurements at these low levels should be stated conservatively. It becomes insignificant on the higher ranges.

Note: The accuracy statement above is based on the "Limit of Error" method and is VALID FOR ONE YEAR calibration cycles. The "Limit of Error" accuracy may be increased to tighten tolerances by:

A) Shortening re-calibration cycle, i.e., more frequently than the suggested 1 year cycle. and/or

B) Elimination of "worst case" conditions by implementing carefully monitored, standards laboratory procedures.

Stability: 8 hrs: 0.00075%; 24 hrs: $\pm 0.001\%$
(*non-additive) 90 days: $\pm 0.0015\%$
1 year: $\pm 0.002\%$

Line & Load Regulation: $\pm 0.0005\%$ No load to full load
(*non-additive) $\pm 10.0\%$ line fluctuation

Noise & Ripple: rms: $\pm 0.0005\%$ of range + 2 uV
In a band pass of 0.1 Hz to 100 kHz

1.3.2 Current Mode

Range	10 mAdc	100 mA
Full Scale	± 11.111 1. mAdc	± 111.111 0 mAdc
Resolution (1 ppm)	10 nanoamperes	100 nA
*Compliance Voltage	0 - 100 Vdc	0 - 100 Vdc
Output Conductance	0.1 uS	0.1 uS

*Note: Voltage Compliance Limit Control

The compliance voltage may be limited via a manually controlled, 6 position switch. The limits are: 100 V, 25 V, 16 V, 12 V, 5 V and 1 V.

Accuracy: (See definitions under Voltage mode)
 $\pm 0.005\%$ of setting + 1 uA

Stability: 8 hrs: $\pm 0.001\%$ 24 hrs: $\pm 0.002\%$
(*non-additive) 90 days: $\pm 0.005\%$
1 year: $\pm 0.0075\%$

1.4.0 General Specifications

Isolation: Power Transformer to analog output:
2.5 x 10⁴ m Ohms, 300 pF
Control logic to analog output; optically isolated.
10⁹ Ohms, 130 pF, 500 Vdc

Temperature Coefficient:
Ambient: $\pm 0.0005\%/^{\circ}\text{C}$
Operating Limit: $\pm 0.001\%/^{\circ}\text{C}$

Switching and Settling Times:
Step Changes: 5 ms
Range Changes: 1 s

Protection: Voltage mode: Short-circuit and overload protection.
Current mode: Open-circuit protection.
Front panel enunciator will indicate malfunction condition. Recovery is automatic.

Warm-up Time: 2 hours

1.5.0 Mechanical Specifications

Power Requirements: 50watts; 115 V or 220 Vac $\pm 10\%$; 50/60 Hz

Temperature: Calibration Temperature: 23°C $\pm 1^\circ\text{C}$
Ambient Temperature: 20°C to 30°C
Operating Limit: 10°C to 50°C
Storage Temperature: -40°C to 85°C

Dimension: Height: W 19 x H 3.5 x D 21 inches
W 480 x H 88 x D 530 mm

Weight: 12.5 lbs., 5.7 kg. Shipping 18 lbs., 8.2 kg.

Terminals: Output: Front panel mounted, 5 way binding posts which are: floating, opto-isolated from the 488 bus, guarded, remote sensed (4 wire) and case ground. Rear panel mounted 6 pin Amphenol spec. connector (mate supplied) with the same functions as those listed for the front panel connections. (No additional charge).

Program: Rear panel mounted connector conforming to IEEE-488 (1978).

1.6.0 General Information

Mounting: Rack mounting facilities; standard 19 inches; 482.6 mm and for bench use with convenient, and removable, tilt bale, included.

Certification: A Certificate of Compliance is issued with each new instrument to certify the calibration traceable to the U. S. Bureau of Standards.

Warranty: Full ONE YEAR warranty on parts and labor and a full ONE YEAR warranty on specifications and performance.

SECTION II

2.0.0 INSTALLATION

2.1.0 Mounting

The 520A is designed for mounting in a standard 19" relay rack. When installing in the rack it is recommended that nylon washers be placed under the mounting screws to prevent scratching the paint.

2.2.0 Mating Connectors

All instruments are supplied with a mating AC power cord and output connector. These are:

	<u>Nomenclature</u>	<u>Part Number</u>	<u>Quantity</u>
1)	AC Power Cord	P 2392	1 ea.
2)	Output Connector	3106A-14S-6P	1 ea.

2.3.0 IEEE Standard 488 Cable

A one or two meter IEEE Std. 488 cable may be obtained from EDC. EDC Part No. 3045-1 or Part No. 3045-2.

2.4.0 AC Power Input Considerations

There is a 110-220 Vac power input voltage selector switch located on the rear panel. For 105-125 Vac use the 110 position, and for the 210-250 Vac use the 220 position. For 100 Vac or 200 Vac, move the wires on the power transformer from lug 3 to 2 and from lug 6 to 5, and use the 110 or 220 position.

2.5.0 Thermal Considerations

The heat generating components are located at the rear 4 inches of the unit. Locate the unit in the rack so that the rear 4 inches are not obstructed by other instruments, so as to permit the free flow of air for this convection system.

SECTION III

3.0.0 OPERATION OF THE INSTRUMENT

3.1.0 FRONT PANEL CONTROLS

3.1.1 Power Switch: Pushon, Push-off line power with associated indicator.

3.1.2 "Remote-Local" Switch: This switch has two positions. In the "local" position the instrument's output is controlled by the front panel switches.

In the "remote" position the instrument is programmed by the IEEE bus, and disables all of the front panel controls. This switch, when in the "local" mode, will override the 488 bus.

3.1.3 Polarity Switch: This switch has 3 positions. "+" polarity denotes that output terminal B, or red terminal, is positive with respect to output terminal C, or black terminal, and vice versa for "-" polarity. The "0" position produces a "crowbar" or short circuit "0" at the output terminals.

3.1.4 Magnitude Switches: There are six. Each one controls one decade of magnitude, and each is settable from 0 to 10.

3.1.5 Range Switch: This is a six position switch selecting the six ranges: 100 mV, 10 V, 100 V, 1000 V, 10 mA or 100 mA.

3.2.0 FRONT PANEL INDICATORS

3.2.1 Decimal Point Indicators: The decimal point always appears in the appropriate position depending upon which range is selected.

3.2.2 Instrument Status Enunciator:

"REM" - indicates the instrument is in the remote mode with front panel controls disabled. The output status, i.e., polarity, magnitude, and range are indicated by the LED displays and is updated as the program is changed.

"LOC" - indicates the local or manual mode. All front panel controls are operational and override any programmed bus commands.

"OVLD" - When illuminated, indicates an overload or possibly shorted condition in the voltage mode. Or, an open circuit condition in the current mode.

NOTE: When the 520A senses an overload condition in the ma range the unit will display "cuold" in the digit display area. When this happens the 520A will reset itself to crowbar and output zero. To return to the current range you must first remove the cause of the overload. Then you must either send more data if you are in remote mode, or turn one of the switches if you are in the local mode.

3.2.3 Range/Function Enunciator:

"mV" indicates millivolt range/and mode
"V" indicates Volt range/and mode
"mA" indicates milliampere range/and mode

3.2.4 Decimal Indicator: A "floating" decimal point is illuminated by several LEDs and properly locates the decimal point for the range indicated.

3.2.5 Magnitude Display Digits Six (6) seven segment displays indicate the analog value of the output. On turn on the segments are tested and at the end of the segment test, the 488 Bus address is displayed for about 15 seconds.

3.3.0 OUTPUT CONNECTIONS

3.3.1 Front Panel Connections: All terminals on the front panel are 5 way binding posts. Spacing is the standard 3/4" centers. Connections are located as follows:

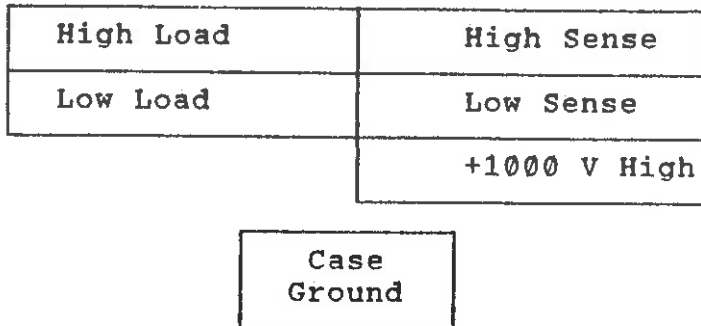

The "load" and "sense" refers to the 4 wire remote sense capability. NOTE: The "load - sense" circuit MUST be complete in either one of two configurations:

For the current mode or for driving high impedances in the voltage mode, only two wires have to be connected to the load. (See configuration B)

However, if an appreciable current is to flow in the circuit, in the voltage mode, i.e. >1 mA, then the sense lines should be connected at the load. (See configuration A)

This 4 wire system eliminates the IR drop and thus maintains the voltage accuracy, of the Model 520A , at the load.

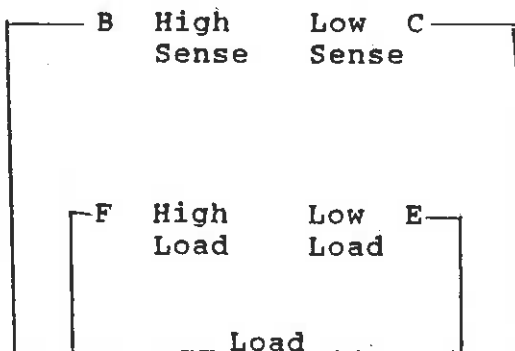

Configuration A

Correct for large load. (4 wires to load, sense connections made at the load.)

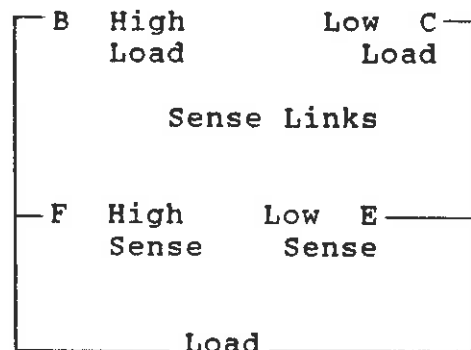

Configuration B

Correct for small loads and current mode. Do not use for large loads. (2 wires to load, sense connections made at the 520A)

3.3.2 Rear Panel Connector:

A	Chassis ground
B	+ (high) load
C	- (low) load
D	No Connection
E	- (low) sense
F	+ (high) sense

The same 4 wire sense procedures apply at the connector as discussed in 3.3.1.

3.3.3 1000 V Output Terminal (front and rear panels):

This connection provides the high (+) 1000 V output at the front and rear panels. This pertains to option RA-5 and is discussed in 6.1.0.

3.3.4 Chassis Ground Terminals These connections on the front panel and at the rear connector are connected to chassis ground.

3.4.0 REMOTE PROGRAMMING VIA THE IEEE 488 BUS.

3.4.1 Introduction. The EDC model 520A is compatible with the IEEE Std. 488/1978. The applicable reference publication is: IEEE Standard Digital Interface for Programmable Instrumentation (IEEE Std. 488/1978).

Publisher: The Institute of Electrical and
Electronics Engineers, Inc.
345 East 47th Street
New York, NY 10017

The <GP-IB> makes it possible for a user to connect various instruments and components together into a functional system. However, this system will not work without the proper software.

The operating system software offers a set of functions and commands which the user can assemble into a written program. Once written, the user's application program, in conjunction with the operation system software, will allow the various instruments on the <GP-IB> to generate signals, take measurements, and allow the instrument controller to manage the resulting information.

All commands sent over the <GP-IB> must be expressed in the controller's own language such as BASIC, FORTRAN, etc.

There are three steps that MUST be taken when using the <GP-IB> to make the system operate. The user MUST:

- a. Understand what tasks must be performed.
- b. Use the controller's language.
- c. Know what kind of information the instruments are capable of exchanging.
- d. READ THE CONTROLLER PROGRAMMING MANUAL THOROUGHLY!!!

3.4.2 Setting The Instrument's Listen Address. The EDC 520A is a "Listen Only" instrument. Its' listen address is set with a "dip switch" located on the rear panel. The digital board is located near the front panel.

NOTE: THE BUS ADDRESS IS DISPLAYED UPON GOING FROM LOCAL TO REMOTE, AND THE DISPLAYED ADDRESS IS THE DEVICE NUMBER THE MODEL 520A WILL RESPOND TO. HOWEVER IF THE ADDRESS SWITCH IS CHANGED WHILE IN THE REMOTE MODE, THE DISPLAY WILL NOT INDICATE THE NEW ADDRESS, ALTHOUGH THE INSTRUMENT WILL NOW RESPOND TO THE NEW ADDRESS.

3.4.2.1 Use switches 1 through 5. They are BINARY coded

SW1	=	Bit 1
SW2	=	Bit 2
SW3	=	Bit 4
SW4	=	Bit 8
SW5	=	Bit 16
ON	=	True
OFF	=	False

Binary numbers 0 through 30 are acceptable. DO NOT SET ALL 5 SWITCHES TO "ON".

3.4.3 Interface Messages. The EDC 520A will respond to the following interface messages:

"MLA". - My Listen Address. Upon receipt of this message, the instrument will enter its listener active state and be ready to accept a string of data bytes. ATN must be true.

"UNL". Unlisten. Upon receipt of this message, the instrument will enter its listener idle state and will not listen to any subsequent data byte strings.

ATN must be true.

"IFC". Interface Clear. Upon receipt of this command the instrument will enter its listener idle state.

"Power-On" Clear. On "Power-On", and remote mode, the instrument will be in the listener idle state and its analog output will be 0.

The instrument will also go to its listener idle state when in the local mode.

3.4.4 Data Byte String Format. In general, the 520A is programmed with an eight character data byte string. ATN must be false on these bytes.

CHARACTER	FUNCTION	ASCII CODES
1	Polarity	+ = Positive Polarity 0 = Crowbar "0" - = Negative Polarity
2	MSD	0 - 10
3	2SD	"
4	3SD	"
5	4SD	"
6	5SD	"
7	6SD	"
8	EOI Range	0 = 100 mV 1 = 10 V 2 = 100 V 3 = 1000 V 4 = 10 mA 5 = 100 mA CR LF or LF if EOI has not been sent

The analog output will change to a new value after receiving the end of message.

NOTE: THE 520A SHOULD SEE AN EIGHT, (8) CHARACTER WORD FOR CORRECT PROGRAMMING. IT WILL ACT ON THE FIRST 8 BYTES. THE 520A MUST RECEIVE AN END OF MESSAGE TERMINATOR TO ACT ON THE MESSAGE.

IT WILL RECOGNIZE CR LF, LF, OR EOI WITH THE LAST BYTE AS A TERMINATOR.

3.4.5.0 SAMPLE PROGRAMS

The following sample programs are intended as guides to help you program this calibrator.

1. The 520A looks for 8 bytes at a time and any additional bytes sent can cause errors.
2. Some software used to communicate between the host computer and the IEEE interface can generate and send unseen bytes which will be interpreted by the 520A as command bytes.
3. Sending an "unlisten" command after each 8 byte command string will reset the 520A's internal counter so that a "listen" command followed by the 8 byte command string will set the unit to a new voltage.

NOTE: THE 520A SHOULD SEE AN EIGHT, (8) CHARACTER WORD FOR CORRECT PROGRAMMING. IT WILL ACT ON THE FIRST 8 BYTES. THE 520A MUST RECEIVE AN END OF MESSAGE TERMINATOR TO ACT ON THE MESSAGE. IT WILL RECOGNIZE CR LF, LF OR EOI WITH THE LAST BYTE AS A TERMINATOR.

In each of the following examples:

The LANGUAGE is in BASIC, unless noted.
The INTERFACE is IEEE-488 (GP/IB)
The ADDRESS is (Binary) 5 with the dip switch set:

1	2	3	4	5	6	7
on	off	on	off	off	off	off

3.4.5.1 Sample Program using:
COMMODORE Models

3.4.5.2 Sample Program using:
HEWLETT-PACKARD
MODEL 9825

3.4.5.3 Sample Program using:
HEWLETT-PACKARD
MODEL 85

3.4.5.4 Sample Program using:
HP1000A w/ 600 Interface
Language: FORTRAN 77

3.4.5.5 Sample Program using:
HP9816S or any HP Series
200 microcomputer

3.4.5.1 SAMPLE PROGRAM Commodore Models

The following sample program is intended as a guide to help you program this calibrator.

```
1  REM MANUAL INPUT PROGRAM FOR EDC. 520A
5  PRINT "{clr home}"
6  ED$="          ELECTRONIC DEVELOPMENT CORP "
10 PRINTED$:PRINT"":PRINT"ENTER POLARITY + OR -"
20 INPUT P$
25 PRINT"{clr home}"
30 PRINT"
31 PRINT" FOR DECIMAL 10 USE J":PRINT""
40 INPUT M$:IF LEN(M$)<>6 GOTO30
45 PRINT"{clr home}":PRINTED$:PRINT""
50 PRINT" ENTER RANGE":PRINT"0 FOR 100 MV":PRINT"1 FOR 10V"
51 PRINT"2 FOR 100V"
52 PRINT"3 FOR 1000V":PRINT"4 FOR 10MA":PRINT"5 FOR 100MA"
60 INPUT R$: IF LEN(R$)<>1 GOTO50
65 PRINT"{clr home}":PRINTED$:PRINT""
70 A$=(P$+M$+R$)
72 REM A$ IS DATA MESSAGE SENT ON THE BUS TO 520A
75 PRINT"":PRINT"          INPUT TO 520A ON THE BUS IS A$, A$="A$
100 T$=CHR$(13)
110 OPEN5,5
120 PRINT#5,A$;T$;
130 CLOSE5
135 PRINT"INPUT COMPLETE":PRINT"":PRINT""
140 PRINT"TO ENTER MORE DATA, PRESS SPACE BAR":PRINT""
150 GETX$:IFX$=""THEN150
160 GOTO5
```

3.4.5.2 SAMPLE PROGRAM Hewlett-Packard Model 9825

The following sample program is intended as guide to help you program this calibrator.

```
1  REM MANUAL INPUT PROGRAM FOR EDC. 520A
5  PRINT"{clr home}"
6  ED$=""
10 PRINTED$:PRINT"":PRINT"ENTER POLARITY + OR -"
20 INPUT P$
25 PRINT"{clr home}"
30 PRINT"    ENTER MAGNITUDE IN SIX CHARACTERS; IE, 123456"
31 PRINT" FOR DECIMAL 10 USE J":PRINT""
40 INPUT M$:IF LEN(M$)<>6 GOTO30
45 PRINT"{clr home}":PRINTED$:PRINT""
50 PRINT" ENTER RANGE":PRINT"0 FOR 100 MV":PRINT"1 FOR 10V"
51 PRINT"2 FOR 100V"
52 PRINT"3 FOR 1000V":PRINT"4 FOR 10MA":PRINT"5 FOR 100MA"
60 INPUT R$: IF LEN(R$)<>1 GOTO50
65 PRINT"{clr home}":PRINTED$:
70 A$=(P$+M$+R$)
72 REM A$ IS DATA MESSAGE SENT ON THE BUS TO 520A
75 PRINT"":PRINT"    INPUT TO 520A ON THE BUS IS A$, A$="A$
100 T$=CHR$(13)
110 OPEN5,5
120 WRT7XX,A$;CHR$(13):REM-OR WRT7XX,"T123456R";CHR$(13);
130 CLOSE5
135 PRINT"INPUT COMPLETE":PRINT"":PRINT""
140 PRINT"TO ENTER MORE DATA, PRESS SPACE BAR":PRINT""
150 GETX$:IFX$=""THEN150
160 GOTO5
```

3.4.5.3 SAMPLE PROGRAM Hewlett-Packard Model 85

The following sample program is intended as a guide to help you program this calibrator.

```
1  REM MANUAL INPUT PROGRAM FOR EDC'S MODEL NUMBER 520A
5  PRINT"{clr home}"
6  ED$="          ELECTRONIC DEVELOPMENT CORP "
10 PRINTED$:PRINT"":PRINT"ENTER POLARITY + OR -"
20 INPUT P$
25 PRINT"{clr home}"
30 PRINT"          ENTER MAGNITUDE IN SIX CHARACTERS; IE, 123456"
31 PRINT" FOR DECIMAL 10 USE J":PRINT""
40 INPUT M$:IF LEN(M$)<>6GOTO30
45 PRINT"{clr home}":PRINTED$:PRINT"":PRINT""
50 PRINT" ENTER RANGE":PRINT"0 FOR 100MV":PRINT"1 FOR
  10V":PRINT"2 FOR 100V"
51 PRINT"3 FOR 1000V":PRINT"4 FOR 10MA":PRINT"5 FOR 100MA"
60 INPUT R$:IF LEN(R$)<>1 GOTO50
65 PRINT"{clr home}":PRINTED$:PRINT""
70 A$=(P$+M$+R$)
72 REM A$ IS DATA MESSAGE SENT ON THE BUS TO 520A
75 PRINT"":PRINT"          INPUT TO 520A ON THE 488 BUS IS A$,
  A$="A$
120 OUTPUT 705 USING "#,K";A$
135 PRINT"INPUT COMPLETE":PRINT"":PRINT""
140 PRINT"TO ENTER MORE DATA, PRESS SPACE BAR":PRINT""
150 GETX$:IFX$=""THEN150
160 GOTO5
```

3.4.5.4 The following program is for the HP1000A with the 600 interface:

```
FTN77
1 C
2 C CHECK EDC SYSTEM
3 C
4 INTEGER IOUT(9),JOUT(9),KOUT(9),LOUT(9)
5 DATA IOUT/'+ 1 2 3 4 5 6 0 _ '/
6 DATA JOUT/'+ 2 2 2 2 2 2 1 _ '/
7 DATA KOUT/'- 3 3 3 3 3 3 0 _ '/
8 DATA LOUT/'+ 6 5 4 3 2 1 0 _ '/
9 C
10 LU = 27
11 C
12 DO I=1,10
13 CALL EXEC(2,100B+LU,IOUT,-17)
14 CALL EXEC(12,0,2,0,-2)
15 CALL EXEC(2,100B+LU,JOUT,-17)
16 CALL EXEC(12,0,2,0,-2)
17 CALL EXEC(2,100B+LU,KOUT,-17)
18 CALL EXEC(12,0,2,0,-2)
19 CALL EXEC(2,100B+LU,LOUT,-17)
20 CALL EXEC(12,0,2,0,-2)
21 ENDDO
22 C
23 END
```

On line4 set integer variable to 9.
On lines 5 thru 8, use space as second byte of word.
Also set last word as underscore character.

On lines 13,15,17 and 19 set binary format and word length to 8 1/2
Lines 14 16 18 and 20 are for delay.

NOTE: CONSULT YOUR HP USER MANUAL FOR THE INTERFACE
CARD THAT YOU ARE USING AS THE DIFFERENT INTERFACE
CARDS IMPLEMENT THE 488 DIFFERENTLY.

REMEMBER <HP1B IS NOT GPIB> AND MAY NOT FULLY IMPLEMENT THE
IEEE-488 (1978) STANDARD.

3.4.5.5 Sample Program using: HP9816S or any HP Series 200
microcomputer

```

100      ! EDC520A with +/-1000V option
110      ! Program to set voltage from keyboard interactively
120      ! using an HP9816S or any HP Series 200 microcomputer
130      ! operating under BASIC 1.0 and above.....
140      ! HP-IB interface #7, 520A Select Code #6
150      ! Ken Moy ----- VARIAN ASSOCIATES (MID) -----      31.JAN.86
160      !
170      Inpt:      !
180      INPUT "ENTER Vr (+/-1111.11 Vmax, up to 6 digits).",Vrr
190      Vra=ABS(Vrr)
200      Vrr$=""
210      IF Vra>1111.11 THEN 430
220      Vrrscl=1*(Vra).111111 AND Vra<=11.1111)+2*(Vra<=111.111 AND
Vra>11.1111)+3*(Vra>111.111)
230      IF Vrr>=0 THEN Vrr${1;1}="+"
240      IF Vrr<0 THEN Vrr${1;1}="-"
250      Vrrscl=Vrrscl-1
260      Vra=Vra*((Vrrscl>0)+10*(NOT Vrrscl))
270      Ct=2
280      REPEAT
290          Vrn=Vra DIV (10-3Vrrscl)
300          IF Vrn>=10 THEN
310              Vrr${Ct;1}="J"
320              IF Vrn>10 THEN Vrn=Vrn-1
330          ELSE
340              Vrr${Ct;1}=VAL$(Vrn)
350          END IF
360          Vra=Vra-(10-3Vrrscl)*Vrn
370          Ct=Ct+1
380          Vrrscl=Vrrscl-1
390      UNTIL Ct=8
400      OUTPUT 706;Vrr$&VAL$(Vrrscl);END      ! END is for EOI only
410      !OUTPUT 706;Vrr$&VAL$(Vrrscl)      ! CR/LF terminator
420      GOTO Inpt
430      DISP "Exceed voltage output capability....<RUN> program
again."
440      END

```

3.5.0 VOLTAGE COMPLIANCE LIMIT CONTROL

This control pertains to the current mode only. It is a means to limit the potential (EMF) of the current output. The control is an internally mounted jumper that may be placed in any one of six positions. The control is located inside the instrument on the mother board.

This control does not effect the operation of the Voltage mode.

<u>Switch Position</u>	<u>Usable Compliance Voltage</u>	<u>Open Circuit Voltage</u>
1 (minimum)	1.2 V	11.2 V
2	8 V	18 V
3	14 V	24 V
4	23 V	33 V
5	65 V	75 V
6 (maximum)	100 V	150 V

4.0.0 520A THEORY OF OPERATION

4.0.1 The Model 520A circuitry is conveniently broken down into functional blocks, discussed in the following sections.

4.1.0 OVERVIEW

4.2.0 CONTROL BOARD

The Control Board has a dual function, it provides the data when the instrument is in the local mode, and contains the displays which operate in both local and remote mode.

4.3.0 MICROPROCESSOR BOARD

The Microprocessor Board (MPU) controls all the operating function of the 520A. In the local mode all switches are continually scanned, and upon detecting a change from a previously stored setting, updates the analog circuits

4.4.0 IEEE 488 LOGIC

Part of the MPU Board circuitry and software is used to control the timing, hand shaking, and data handling necessary to transfer data from the bus to the Model 520A Digital to Analog circuits.

4.5.0 DIGITAL TO ANALOG CIRCUITS (DAC)

The DAC circuits are located on the mother board of the Model 520A. Data from the MPU Board is sent to a 24 bit digital to analog converter. The timing and clock circuits signals also appear here. The necessary weighting components are located within this circuit.

4.6.0 OUTPUT AMPLIFIER

The DAC output is fed through an electronic DPDT switch to the input stage of the Output Amplifier. This stage boosts the DAC voltage to the level required by the magnitude data received from the Digital Circuits. Current amplification required to drive the load on the output terminals is also generated in these stages.

4.7.0 VOLTAGE OUTPUT

The voltage appearing at the output of the amplifier is channeled to the output terminals and the appropriate feedback, or sensing resistors through relays selected from data derived from the MPU Board.

4.8.0 RANGE LOGIC

The important function of selecting the correct relays for the range and function required is done by the Range Logic circuits. The timing necessary for preventing switching transients from appearing at the output terminals is dealt with by these circuits. The "Crow Bar" feature, exclusive to the Model 520A is also accomplished by the Range Logic Circuits.

4.1.0 INTRODUCTION

4.1.1 On POWER ON the MPU first sets the 520A to the CROWBAR mode to minimize analog turn-on transients from appearing at the output terminals.

4.1.2 The MPU proceeds to initialize the data registers, and perform other overhead and housekeeping chores. The display segments are cycled through. Upon completion of the initialization routines, the IEEE 488 bus address switch is read, stored in memory and displayed on the front panel.

4.1.3 If the power-up sequence was started with the REMOTE/LOCAL SWITCH in LOCAL the MPU reads the setting of the front panel switches, and stores the information in the DAC. The output and displays are updated. If power-up was in REMOTE the display will hold the Bus Address until valid data is received by the 520A

4.1.4 The MPU monitors the REMOTE/LOCAL, POLARITY, AMPLITUDE, and RANGE switches. If the REMOTE/LOCAL SWITCH remains in the LOCAL position, the front panel switch settings are read into temporary registers, and compared with data stored in the working registers. If the data is the same, the data is ignored and the displays are refreshed and the switches are read again.

4.1.5 When a change of data appears in the temporary registers, the data is transferred to the working registers, manipulated, and sent to the DAC. The DAC, and output, with polarity and range changes as necessary, are updated, as are the displays. The MPU then returns to reading the front panel switches.

4.1.6 On detecting the REMOTE/LOCAL switch in the REMOTE. The MPU places the 520A in the "CROW BAR MODE", reads the Address switch and displays the IEEE 488 Bus Address.

4.1.7 Utilizing the interrupt capabilities of the 68488, the MPU removes the interrupt mask and waits for an interrupt from the Bus Controller.

4.1.8 The EDC MODEL 520A, (in REMOTE mode), until receiving an interrupt from the 68488 will refresh the displays, and monitor the LOCAL/REMOTE switch.

4.1.9 An IRQ tells the internal MPU that the controller has received a byte of data which has been sent to the unit's address. The EDC MODEL 520A will now go to it's DAC update routine.

4.1.10 When the 520A Bus Address is read, a MLA flag is set by the MPU, and the ATN is monitored until it goes false. At that time the MPU checks the MLA flag. If set it reads the next 8 bytes and stores them in temp registers.

4.1.11 The 8 bytes are compared to previously stored 488 data, and if the new data is not the same updates the DAC and output, sets the new values in the displays, and goes back to monitoring the REMOTE/LOCAL switch, and refreshing the display.

4.2.1 The CONTROL BOARD contains the manual switches, mode annunciators, decimal point LEDs, and seven segment displays required for manual operation of the MODEL 520A.

4.2.2 The 6 seven segment displays, the polarity display are multiplexed under control of the MPU. A driver chip is on the CONTROL BOARD to interface the MPU with the individual segments.

4.2.3 The digit strobes also strobe the six decade switches simultaneously with the six displays. A logic "low" on a strobe line enables the display and reads the information from the associated switch. The POLARITY SWITCH, and RANGE SWITCH are also strobed and their BCD data output to the MPU. The sequence of reading the switches is; RANGE, LSD-MSD, POLARITY.

NOTE: THE REMOTE/LOCAL SWITCH IS READ SIMULTANEOUSLY WITH THE READING AND STROBING OF THE FRONT PANEL, THEREBY ASSURING CONTINUOUS MONITORING OF THE STATUS OF THE REMOTE/LOCAL SWITCH

4.2.4 The enabled switch connects the strobe low to appropriate lines on the four "BINARY Output" lines. The normal binary output is "0" through "10". The display will carry over to the next decade on receiving an input over BCD "9". The analog circuitry will give an output of appropriate weight (10).

4.2.5 The outputs of the decade switches are sent to the MPU.

4.2.6 The LOCAL REMOTE switch illuminates the local/remote indicator on the front panel. It also sends a high/low signal to the MPU to set up manual or remote (IEEE 488) control of the 520A's analog function. A high, (logic 1), on the rem line signifies the remote mode.

4.2.7 The "OVLD" indicator, displays an "inoperative" analog mode (shorted or overloaded output, or no output when a specific voltage/current is dialed up). When the malfunction is removed, the light will go out.

4.2.8 The signal for the "OVLD" indicator comes from the analog section of the mother board.

4.2.9 The polarity indicator is a + or - segmented LED.

4.2.10 The polarity switch is similar to the decade switches except that only 2 lines, pol. 1 and pol.2, are used, permitting four states of which three are used in the selection of polarity.

4.2.11 The binary outputs of the POLARITY switch are:

zero = minus
one = crowbar
two = positive

The outputs are sent to the MPU.

4.2.12 The RANGE switch is also a BCD switch with three of its four output lines used. This permits the selection of eight ranges of which six are presently implemented.

4.2.13 The Binary outputs of the RANGE switch are:

zero = 100 Mv
one = 10 V
two = 100 V
three = 1000 V (with RA-5 option)
four = 10 mA
five = 100 mA

The outputs are sent to the MPU.

4.2.14 The range lights are controlled by inputs from the MPU.

4.3.0 MICROPROCESSOR CIRCUITS (Figs B-3981/B-3998)

4.3.1 The Model 520A employs the industry standard microprocessor 65XX family of circuits, 6502CPU and 68488, and standard off the shelf logic circuits.

4.3.2 The MPU control consist of the CPU, RAM, ROM, I/O, clock and power on/reset circuits.

4.3.3 The timing of the circuit is set by the crystal oscillator and Z13. The system clock is set at 1.7Mhz.

4.3.4 Power on and reset are controlled by Z15 and it's associated circuitry. This assures the MPU will start up in a given state. Provision has been made to reset/restart the MPU without powering down, to aid in possible troubleshooting of the unit.

4.3.5 Z7 & Z8 Decode the address information on the bus to enable the memory addressed. Z6 further decodes 9000hex to specific I/O devices located at memory locations 900Xhex.

4.3.6 4k of ROM, located at FXXXhex, contains the operating system of the Model 520A. An expansion socket is available at location EXXXhex which may accommodate RAM or ROM, to facilitate future expansion.

4.3.7 4k of RAM has been located at 0XXXhex. Most of the data received from the front panel switches, or the IEEE 488 Bus is manipulated on 'Zero Page'. The use of the 6502's zero page addressing modes enhances the speed and performance of the Model 520A.

4.3.8 Each display and it's corresponding digit display is strobed simultaneously. The display strobe is handled by the output latch Z12, BCD to decimal decoder Z23, and output driver Z26. The display sequence is LOC/REM; POL; MSD - LSD; RANGE

4.3.9 The display addressed by the strobe from Z26 is updated, or refreshed at this time. The individual segments of the seven segment LED display are addressable by the CPU through the latch Z11. Z24 & Z25 are buffers which feed the segment driver located on the CONTROL BOARD.

4.3.10 The switch addressed by this strobe has it's BCD data placed on the common output lines of the switches, and is read onto the internal data bus through input latch, Z19

4.3.11 Decimal point lights, range, and local/remote, and polarity annunciators are turned on and off by output latches Z21 and Z22

4.3.12 Digital data, ie: data clock, serial data, and data strobe, are sent to the DAC Circuits by Z22. Further description of these signals is located in the DAC section of this manual, section 4.5.0.

4.3.13 Selection of the proper range relays is accomplished at the output of latch Z20. See Section 4.8.0 for description of the range logic.

4.3.14 Data read from the POLARITY, MSD-LSD, AND RANGE switches is compared with information stored from a previous reading, if the data is the same, then the new data is ignored. This minimizes the chance of misinformation or glitches getting into the DAC, as it is only updated when new valid data is present.

4.4.0 IEEE 488 LOGIC CIRCUITS (Fig B-3997)

4.4.1 The Model 520A is a listener only, as defined by the IEEE 488 standard. The IEEE 488 interface as implemented in the Model 520A is done with a 68488 bus interface, 2 MC3447 bus receiver/drivers, 74244 input latch.

4.4.2 An address switch is mounted on the rear panel, for selecting the address of the Model 520A on the bus.

4.4.3 In LOCAL mode the EDC MODEL 520A internal circuitry does not respond to any activity on the IEEE 488 bus. When the unit is placed into the REMOTE mode, bus activity is monitored and the MPU interrupt bus will respond to activity directed to the address of the EDC MODEL 520A

4.4.4 Connection to the IEEE 488 is through a ribbon connector, plugged into the mother board. Interface between the IEEE 488 bus signals and the 68488 bus interface are through two MC3447 bus transceivers.

4.4.5 Z10, an input latch, is used to read the setting of the ADDRESS switch. Each time the Model 520A is switched to the REMOTE position, and on POWER ON the setting of the this switch is read, stored into a register, and displayed on the front panel.

4.4.6 The data transmitted over the bus is stored in temporary data registers until all of the data has been received. The data is then compared to data already presented to the DAC, if it is the same then the data is ignored.

4.4.8 If new data is detected, the MPU locks out responses to the IEEE 488 bus, and updates the DAC. The MPU returns to monitoring the IEEE 488 bus and the REM/LOC switch.

4.5.1 The DAC converts the digital data from the MPU Board to an analog reference voltage.

4.5.2 The DAC consists of a reference circuit, a 24 bit serial to parallel converter, a 24 bit DAC, analog buffers and summing amplifier.

4.5.3 The precision reference circuit consists of Q101, Q102, & D103. The output is a precise 0 TC voltage. This voltage is applied across a divider with 10 output voltages tapped at 500 mV intervals.

4.5.4 The divided voltages are applied to parallel inputs of 12 analog switches, Z117A through Z122B.

4.5.5 Z117A & B are typical of the analog switches. The lower voltages from the divider, V0 through V7 are applied to Z117A, and the higher voltages V8-V10 to the inputs of Z117B.

4.5.6 The analog switches are 8 channel analog multiplexers. The input codes 000 to 111 connect the corresponding input to the output pin of the multiplexers. The "4" bit input is used to inhibit the Z117 A or B section not being used, through inverters Z130.

4.5.7 Z114 through Z116 are serial in, parallel out, shift registers. The outputs are applied as digital inputs to the analog switches Z117 - Z122.

4.5.8 A "clock" pulse from the MPU Board is buffered into the DAC section by Z109 and opto coupled by Z111 to the clock inputs, (pin 1), of Z114-Z116.

4.5.9 The serial data from the MPU Board is buffered into the DAC section by Z109, and opto coupled by Z110 to pin 2 of Z116.

4.5.10 The clock pulses step the serial data thru the 8 bit shift and store registers. After 24 clock pulses, which represent 6 decades of 4 bit information, a strobe signal on pin 3 of Z114-Z116 transfers the data stored in the shift registers, to their outputs. These output levels are applied to the digital inputs of Z117 - Z122.

4.5.13 The analog outputs from Z117-Z122 are buffered by ICs Z102-Z105. The decade weighting and summing is accomplished by R140-R145.

4.5.14 Inverting amplifier Z101 sums and buffers the analog output of the DAC.

4.6.0 OUTPUT AMPLIFIER (DWG B 3808)

4.6.1 The output amplifier is a bipolar amplifier which takes the output of the DAC, and amplifies and boosts the current capabilities of the 520A.

4.6.2 Q301 to Q308 accomplish the level shifting and current amplification of the output amplifier.

4.6.3 Z303 is the summing stage for the input from the DAC and the feedback circuitry of the amplifier.

4.6.4 Polarity switching is handled by Z109, Z301, and Z305.

4.6.5 When the polarity is reversed, the "pol" bit is applied to the buffer input of Z109. The buffer drives the opto-isolator. The output of the opto-isolator controls the gates of Q311-Q314 through inverter Z301.

4.6.7 DAC GND is tied to the drain of Q311 and Q313. DAC OUTPUT, (a negative output voltage), is applied to the source of Q312 and Q314.

4.6.8 The input to the output preamplifier stage goes through a 1K resistor to the source of Q311 and the drain of Q314.

4.6.9 Signal GND is connected to source of Q313 and the drain of Q312.

4.6.10 Z301 biases on Q311 & Q312, and biases off Q313 and 314 for positive output. For negative output Z301, switched by Z305 biases off Q311 & Q312 and biases on Q313 & Q314.

4.7.0 OUTPUT SWITCHING (DWG B 3809)

4.7.1 In the 10V range the feedback resistor is R335. This resistor is in all the range feedback circuits. Relays K2, K3, & K8 connect the output of the power amplifier to the output terminals.

4.7.2 In the 100V range, R336 and R337 are placed in series with R218. Relays K1, K3 & K8 connect the output to the output terminals.

4.7.3 The 100 MV range places the output of the PA across a 100/1 divider network. R335 becomes the feedback resistor. Relays K4 and K7 connect the feedback paths, and the output terminals to the output of the divider.

4.7.4 In the mA ranges, R335 now becomes the feedback resistor, however the output current is sensed by measuring the voltage developed across special resistors. K7 and K3 are also energized in this range.

4.7.5 In the 100 MA range the output current is sampled by R224-R226. The voltage is applied to the feedback circuit by K5.

4.7.6 In the 10 MA range the output current is sampled by R227-230. The resultant voltage is applied to the feedback circuit by K6.

NOTE: To provide the various output modes of operation, and obtain the accuracy and stability required ultra low thermal relays are used exclusively.

4.8.0 RANGE LOGIC (DWG B 3992)

4.8.1 The range selection and timing is controlled by the MPU Board.

4.8.2 Upon receipt of a range change command, the MPU inputs "zeroes" to the DAC, forcing the output to zero. 100 milliseconds later the new range data is loaded into the range relay drivers.

4.8.3 200 milliseconds after the the initial range change command. the new magnitude information is entered into the DAC, and through the selected range relay, to the output terminals.

4.8.4 When the polarity switch is placed in "0", or Zero polarity is sent over the IEEE 488 bus a separate line from the MPU turns on the Crowbar relay.

4.8.5 With the 1000V option installed, three of the range select lines are tested before 1000V range operation can be energized.

SECTION V

5.0.0 CERTIFICATION AND TESTING

5.1.0 RECOMMENDED EQUIPMENT

Use Datron Model 1071, 1072 or equivalent; L & N Thomas 100 ohm standard resistor or equivalent.

5.2.0 CALIBRATION PROCEDURE

Refer to Drawing No. B-3893. The test points are across the output terminals except on Steps 1, 19 and 20.

STEP	FRONT PANEL SETTINGS		ADJ	TEST VALUE	COMMENTS
1	Irrelevant		R11	Voltage on tag	Connect DVM to Ref. Zener test points.*
2	Range=10 V Magnitude=0		R17		Alternately switch between + and - polarity, adj.R17 for equal offset errors.**
3	Range=10 V Magnitude=0 Polarity=+		R12	0, i.e., absolute value <10uV	Switch to - pol. on 10 V range.
3A	Range=100V Magnitude=0		R23	0, i.e., absolute value <50uV	Alternately switch between + and - polarity, adj. R23 for equal offset error.
4	1	on MSD	R1	1 V ± 10 uV	Range = 10 V Polarity = + If one of the steps 4-13 cannot be calibrated, adjust problem pot to mid trim, adjust R13 to give correct output, and repeat steps 4-13.
5	2	on MSD	R2	2 V ± 20 uV	
6	3	on MSD	R3	3 V ± 20 uV	
7	4	on MSD	R4	4 V ± 20 uV	
8	5	on MSD	R5	5 V ± 30 uV	
9	6	on MSD	R6	6 V ± 30 uV	
10	7	on MSD	R7	7 V ± 40 uV	
11	8	on MSD	R8	8 V ± 40 uV	
12	9	on MSD	R9	9 V ± 50 uV	
13	10	on MSD	R10	10 V ± 50 uV	
14	10	on 2SD	R14	1 V ± 10 uV	
15	10	on 3SD	R15	100 mV ± 10 uV	
16	10	on 4SD	R16	10 mV ± 10 uV	
17	10	on MSD Range=100 V Polarity=+	R18	100 V ± 500 uV	
18	10	on MSD Range=100 mV Polarity=+	R19	100 mV ± 2 uV	

* SEE NOTES ON NEXT PAGE

FRONT PANEL

STEP	SETTINGS	ADJ	TEST VALUE	COMMENTS
19	10 on MSD Range=10 mA Polarity=+	R20	1 V ± 20 uV	Use 100 ohm precision 4 wire resistor connected across output terminals. Connect DVM to output terminals of resistor.
20	10 on MSD Range=100 mA Polarity=+	R21	10 V ± 50 uV	

* Do NOT attach DVM leads directly across the reference Zener diode. Use the test points indicated in drawing B-3893. These points are equivalent to the Zener anode and cathode.

** Output is adjusted via R17 for equal magnitude but opposite polarity. The polarity of the output voltage does not necessarily have to correspond to the front panel polarity switch setting.

1000V Option RA-5

6.0.0 Description and Specifications.

6.1.0 The Electronic Development Corporation Model RA-5 is a modular subassembly which extends the range of the EDC Model 520A to 1100 volts, in either polarity.

6.2.0 Electrical Specifications.

Output voltage Max.	±1000Volts
Resolution	1mV (1ppm)
Output Current	5 mA
Settling time:	2 seconds within the range 8 seconds for polarity or range change
Accuracy	±(0.004% of setting + 5mV)

Note: Using the 1000V range at less than 10V, is not recommended, as a degradation of the accuracy spec may take place. A zero setting in this range could result in an offset of <1V for approximately 10 seconds.

6.3.0 Calibration (DWGS B-4021 B-4045)

Dial up or remotely program the Model 520A to 1000V, positive polarity. Adjust the potentiometer on the RA-5 for exactly 1000V output.

CAUTION

DUE TO THE HIGH VOLTAGES PRESENT AT THE
OUTPUT TERMINALS, CAUTION SHOULD BE
EXERCISED WHEN THE UNIT IS BEING OPERATED
IN THE 1000V RANGE.

MPU FLOW CHART (SIMPLIFIED)		ENGR: RL/DD	
ELECTRONIC DEVELOPMENT CORPORATION	DRAWING NO: M-4028	REV	BY: CY
	DATE: 1987	MODEL: 520	

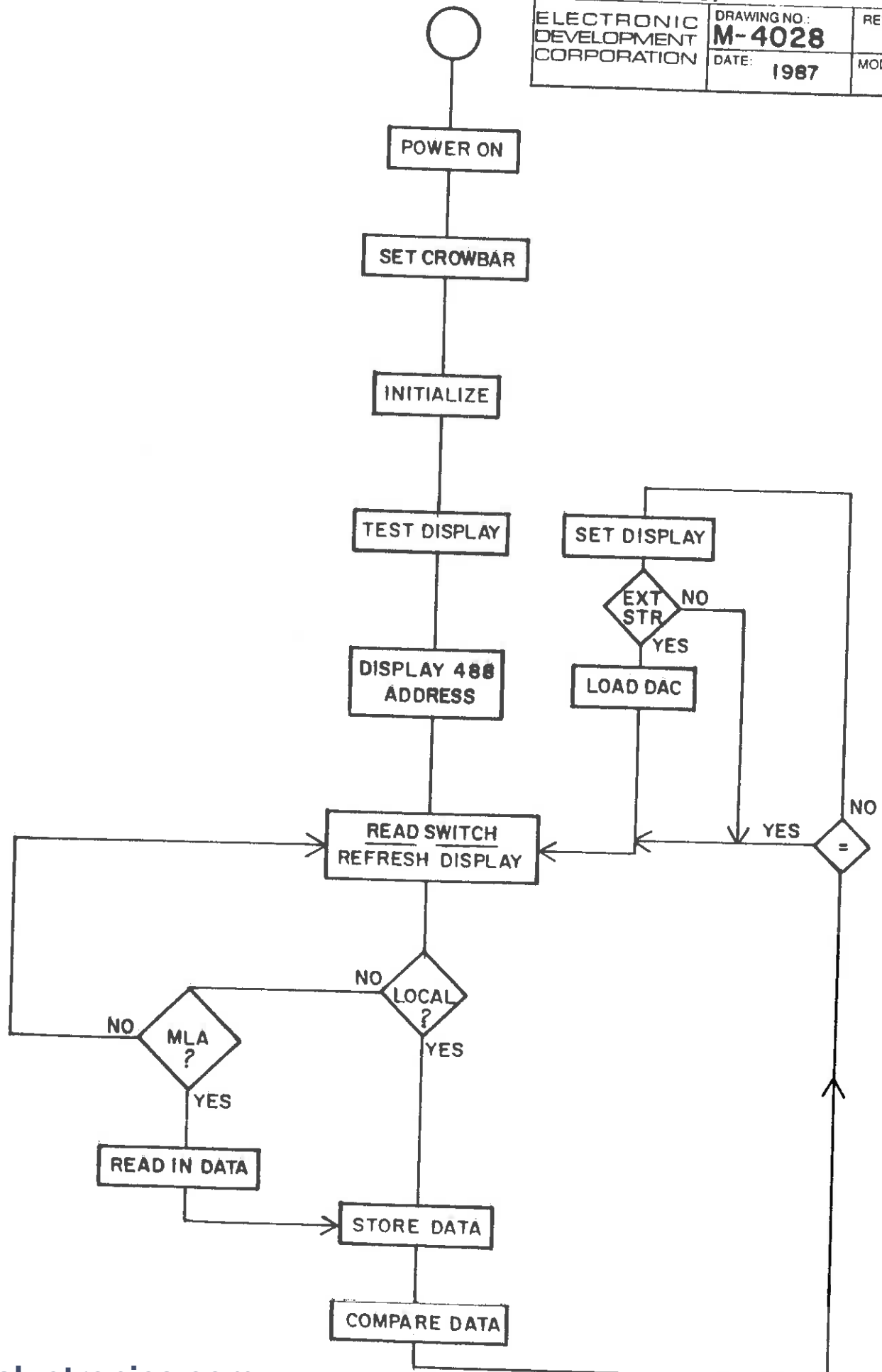

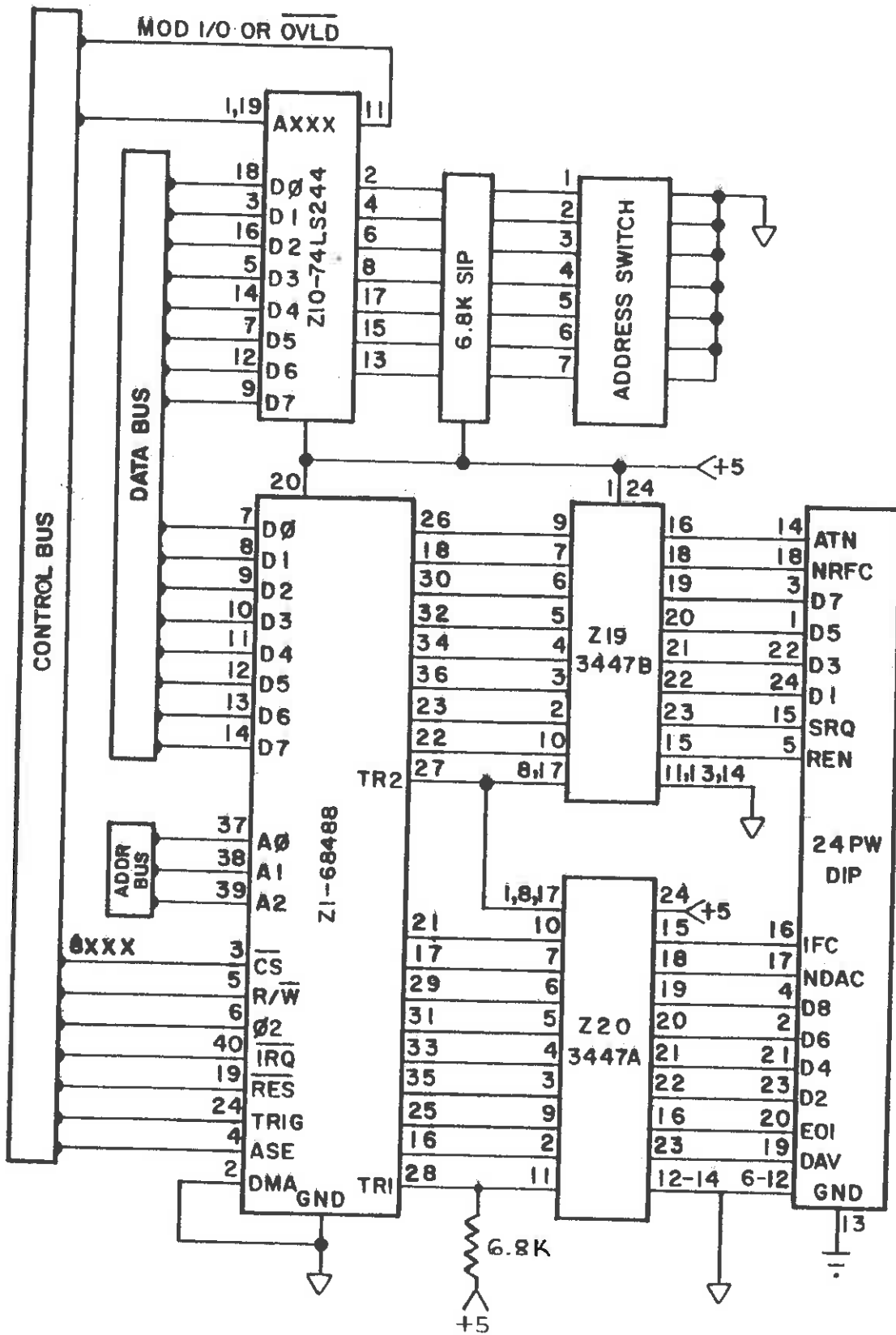

TITLE: MPU-488 INTERFACE		ENGR: RL/DD	
ELECTRONIC DEVELOPMENT CORPORATION 11 HAMLIN STREET, BOSTON, MASS. 02127		DRAWING NO. A-4043	REV BY D CY
DATE: 9-12-86		MODEL: 408,520	

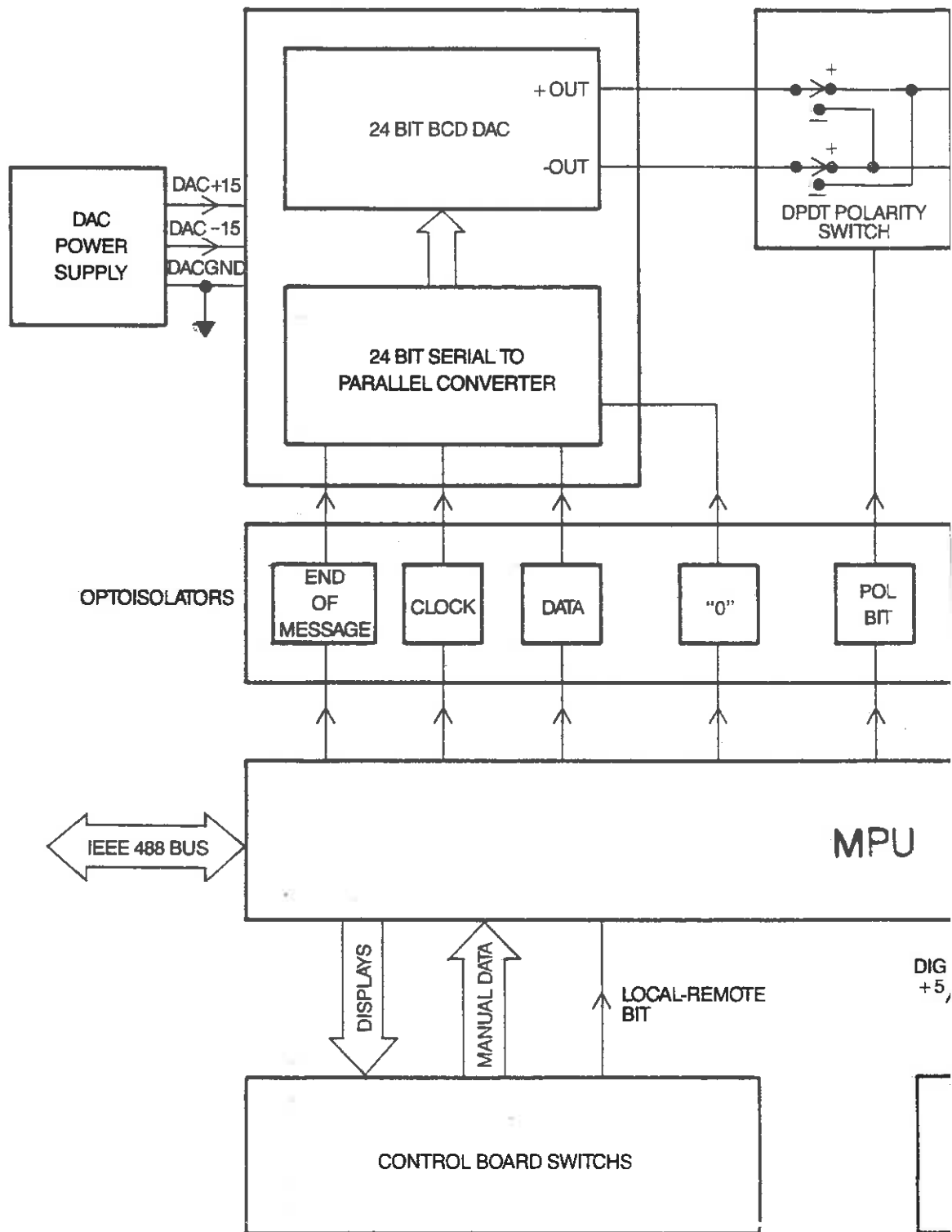

DIG +5,

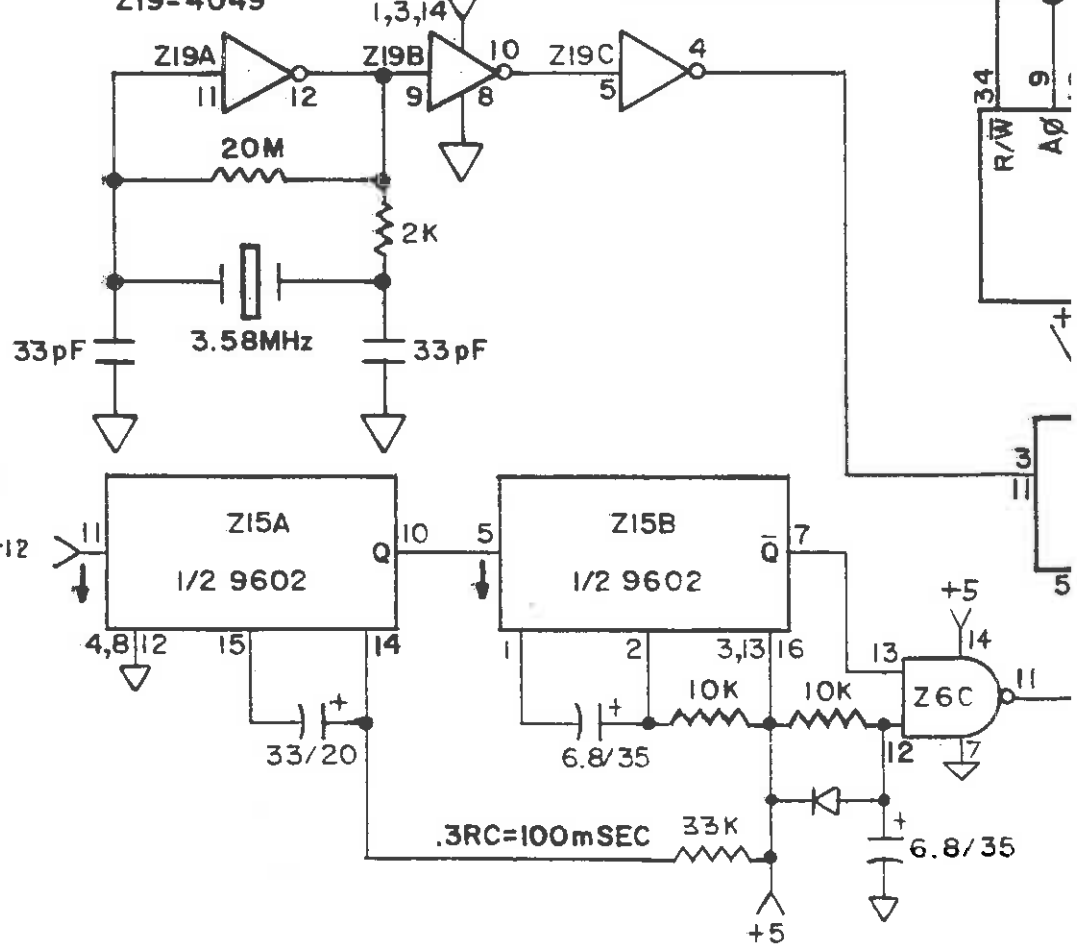
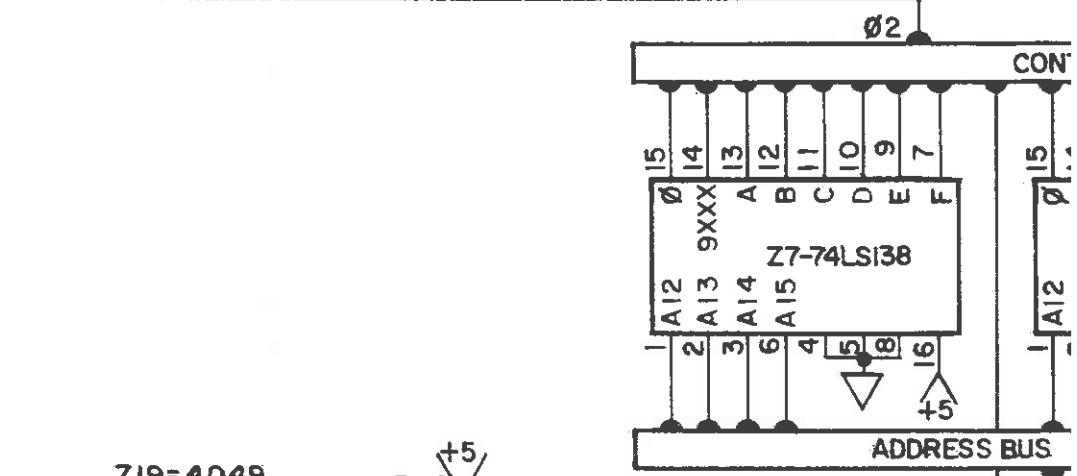
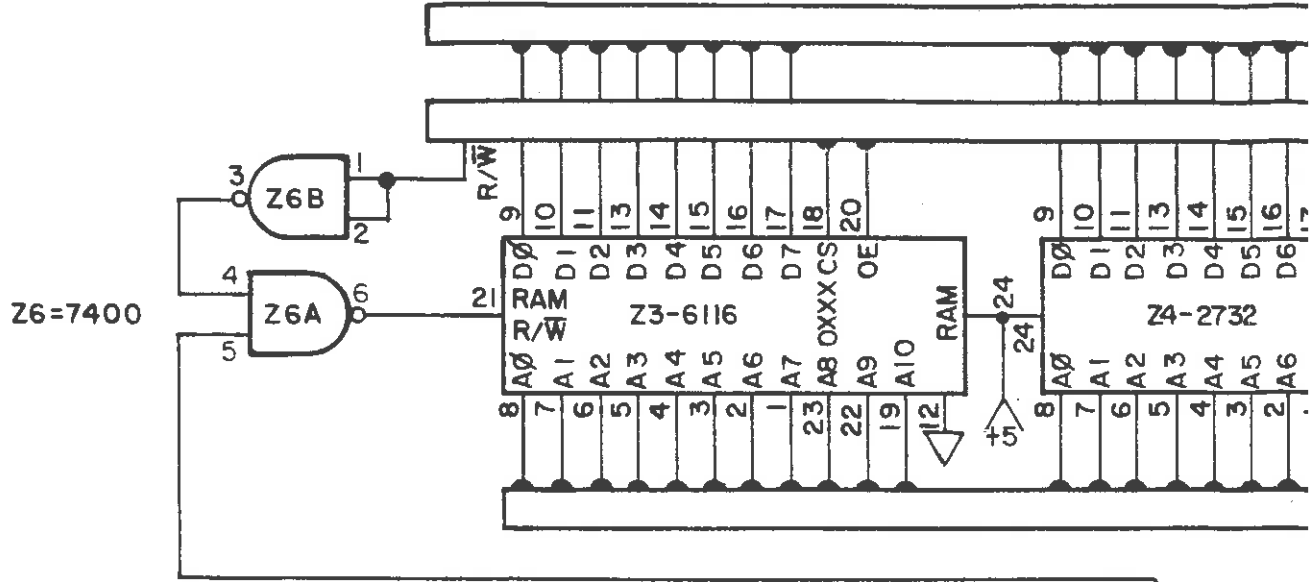

NOTES:
 0.1/16 CAP BETWEEN +5 AND
 GND. ON ALL I.C. CHIPS

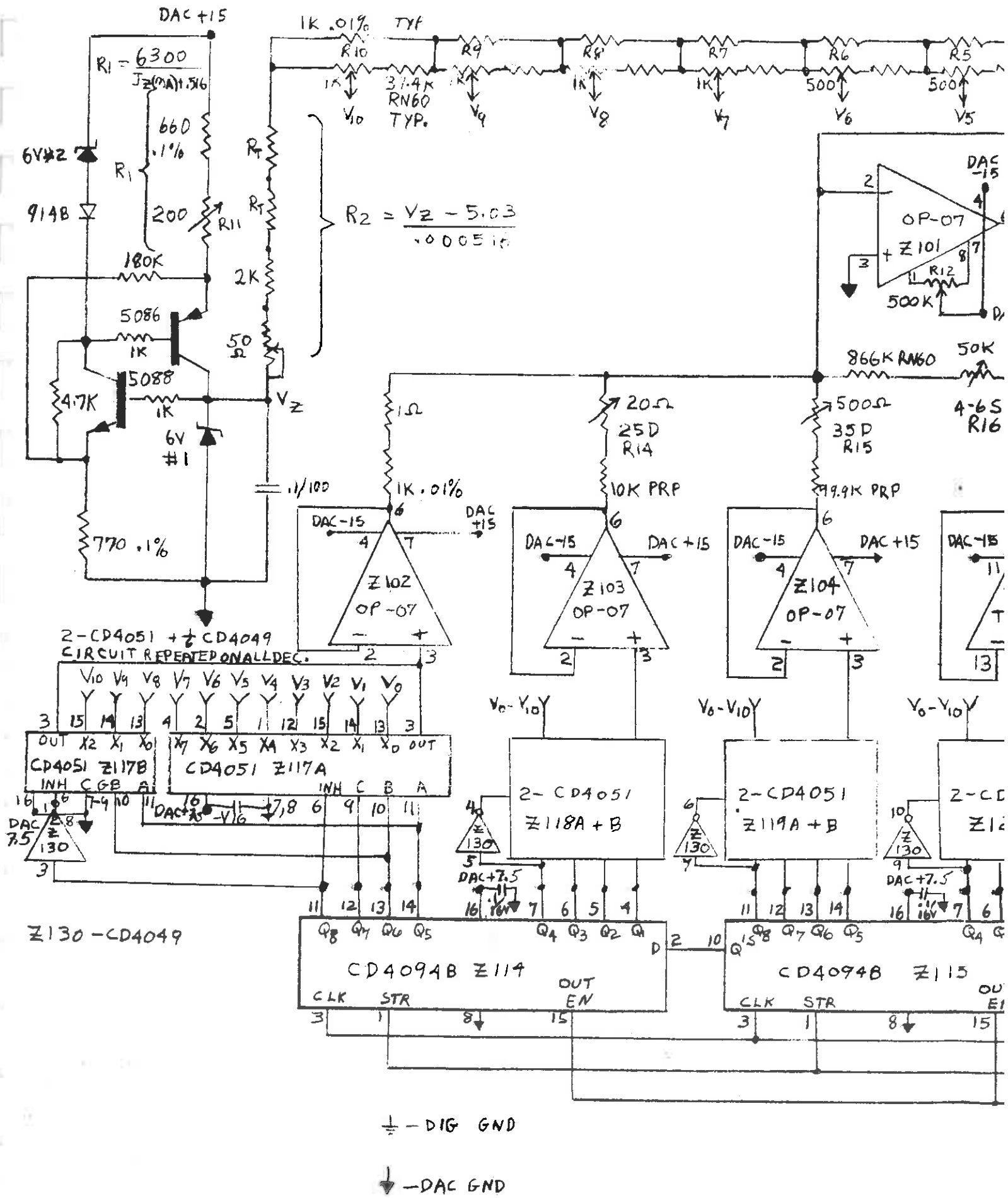

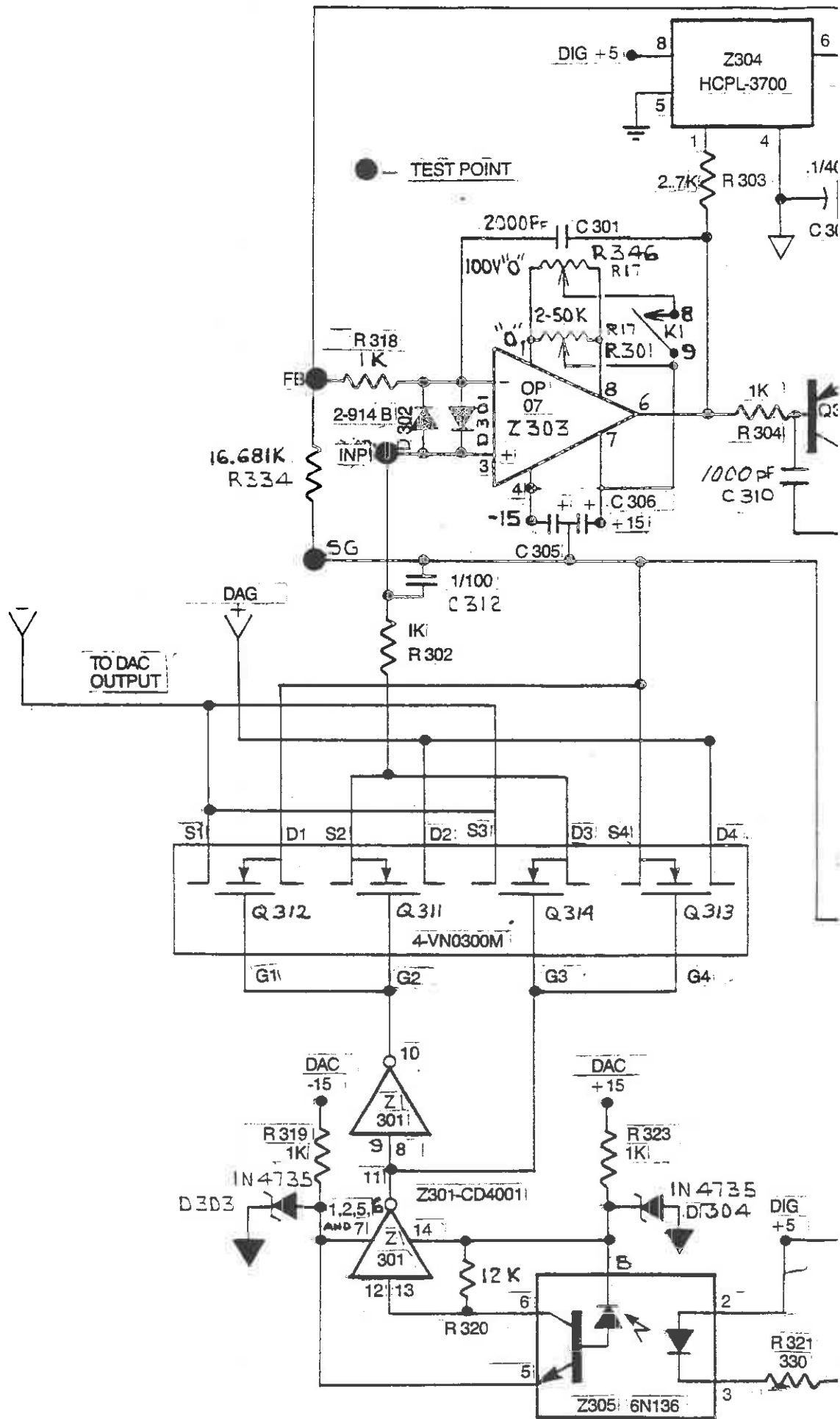

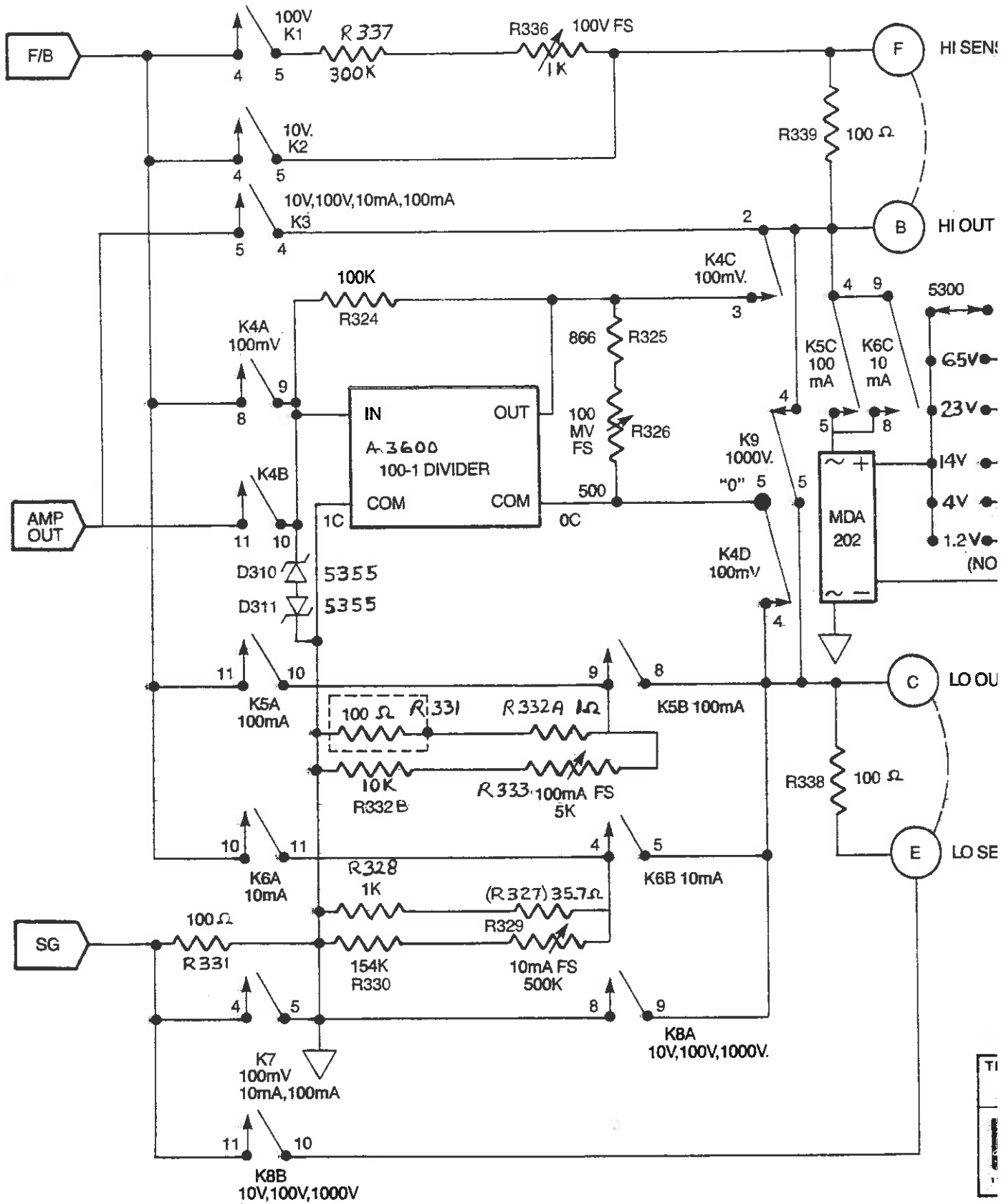

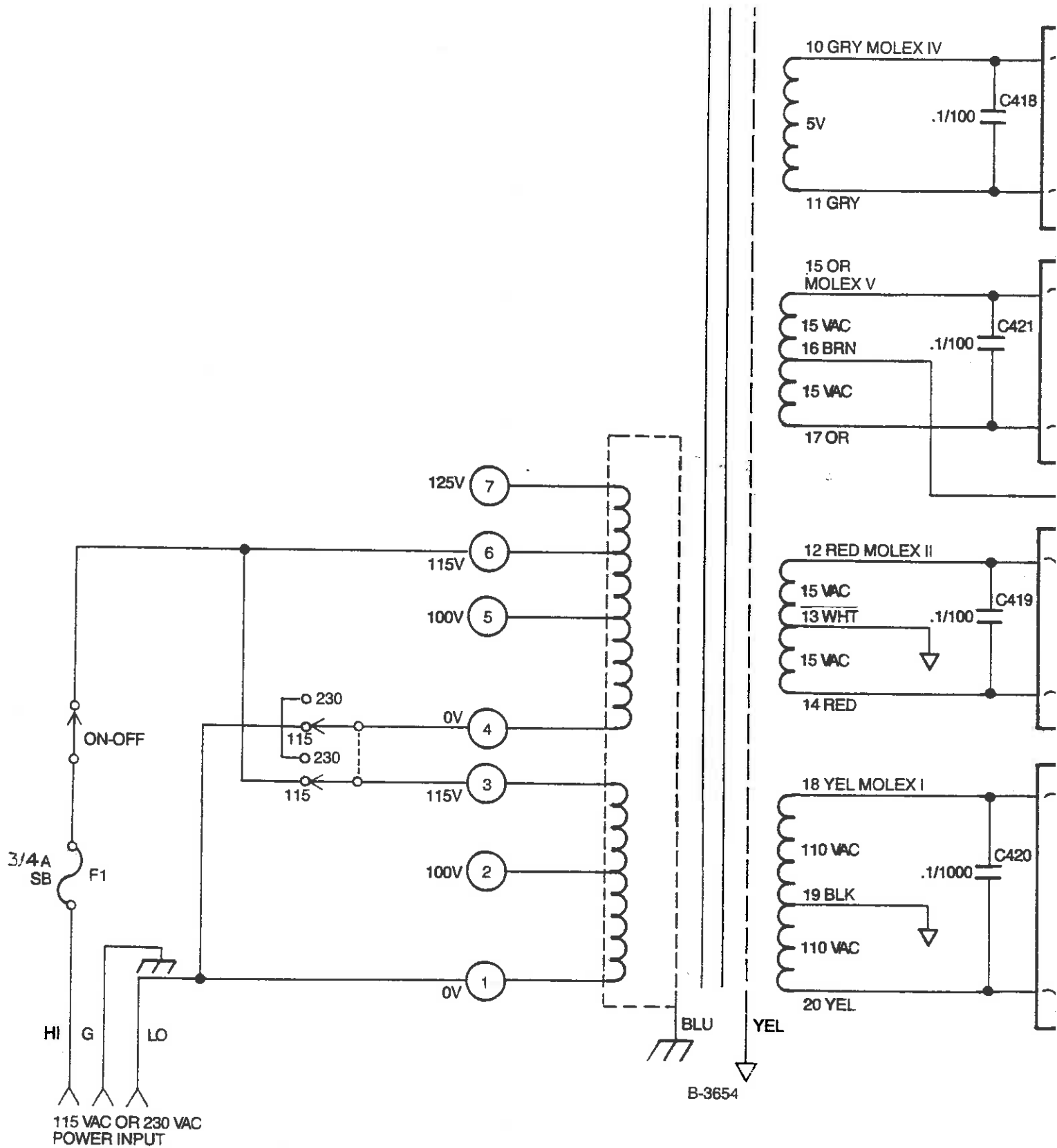

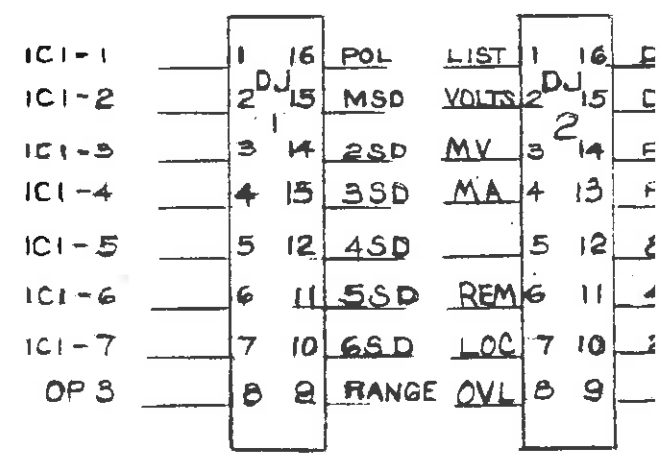
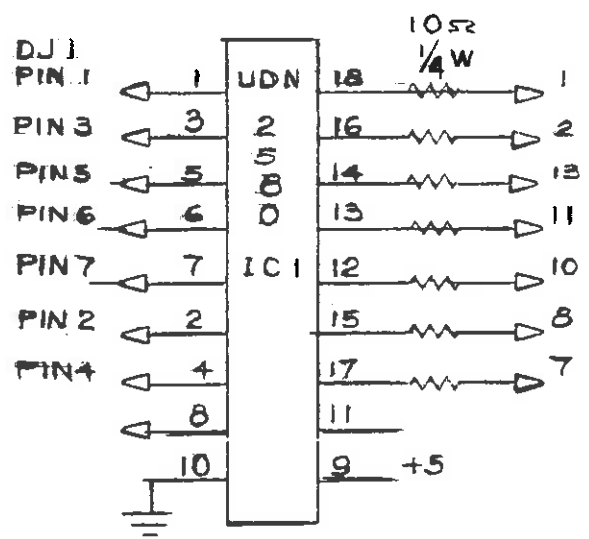
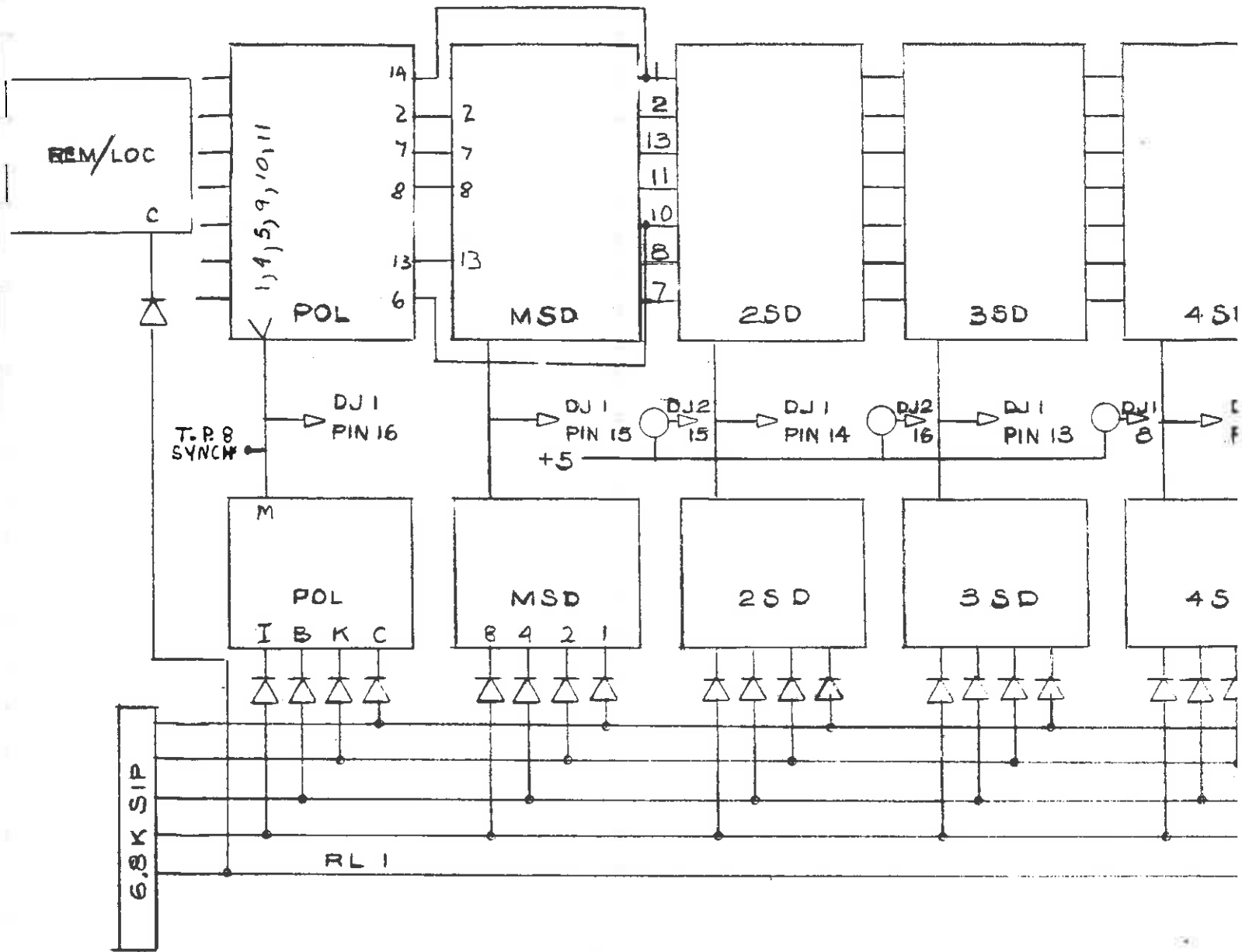

MODEL 520		DATE 6-20-87	11 HAMLIN STREET, BOSTON, MASS. 02127
REV. BY	DRAWING NO. B3922 B	ELECTRONIC DEVELOPMENT CORPORATION	
ENGR.	TITLE RANGE LOGIC MPU		

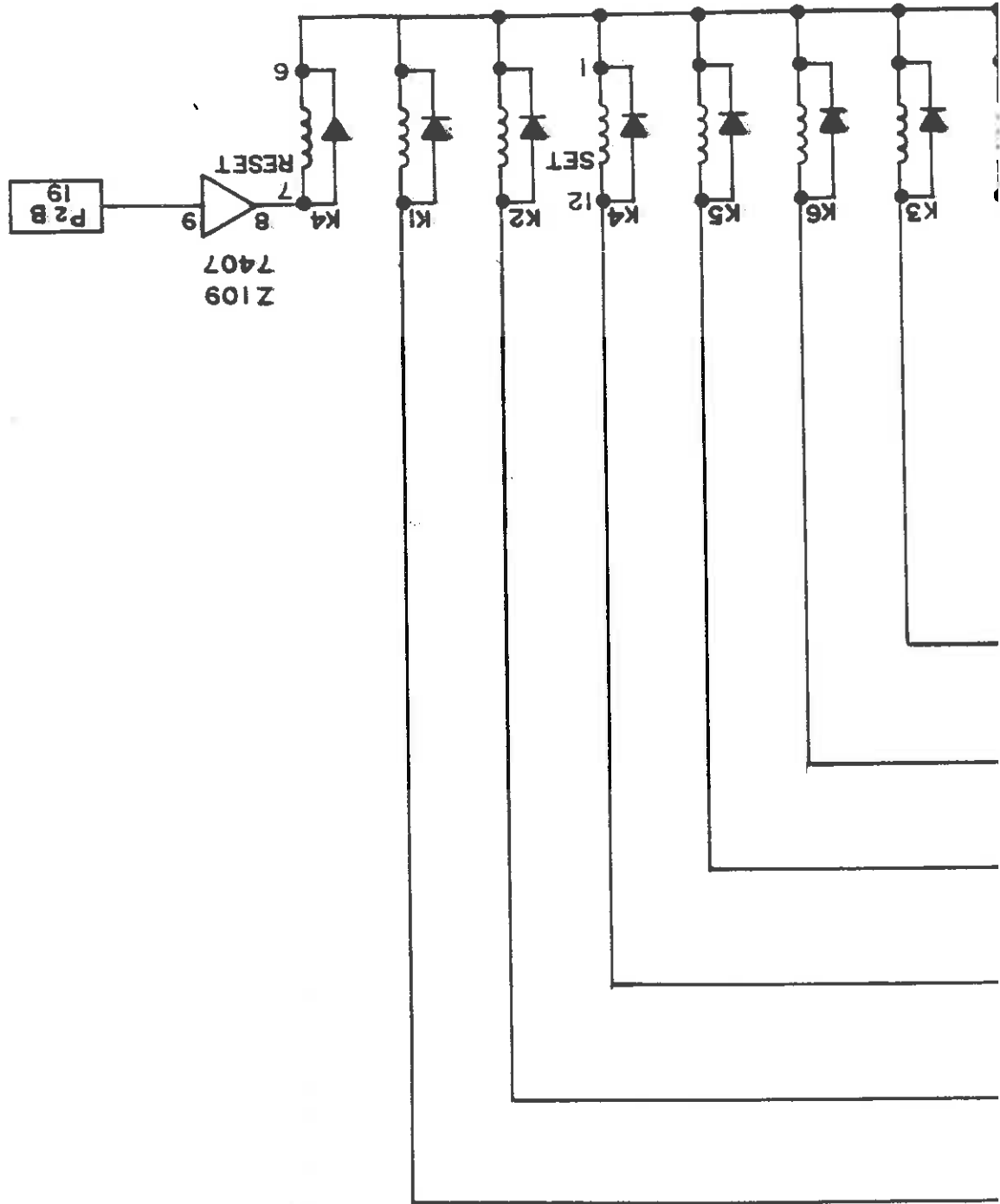

ELECTRONIC DEVELOPMENT CORPORATION
 11 HAMLIN STREET
 BOSTON, MA 02127-4198
 TEL: (617)268-9696
 FAX: (617)268-6754

FACSIMILE COVER SHEET

FAX NO: 410 584 7561 PHONE NO: 410 384 7400
 TO: EIL INST. LOCATION: _____
 ATTN: RKH DEY (CAL LAB) DATE: 11-13-95
 FROM: PAUL LIVINGSTONE

NUMBER OF PAGES, INCLUDING THIS PAGE (1) OPERATOR ()

COMPONENT LAYOUT FOR EDC MODEL 520 POWER SUPPLY

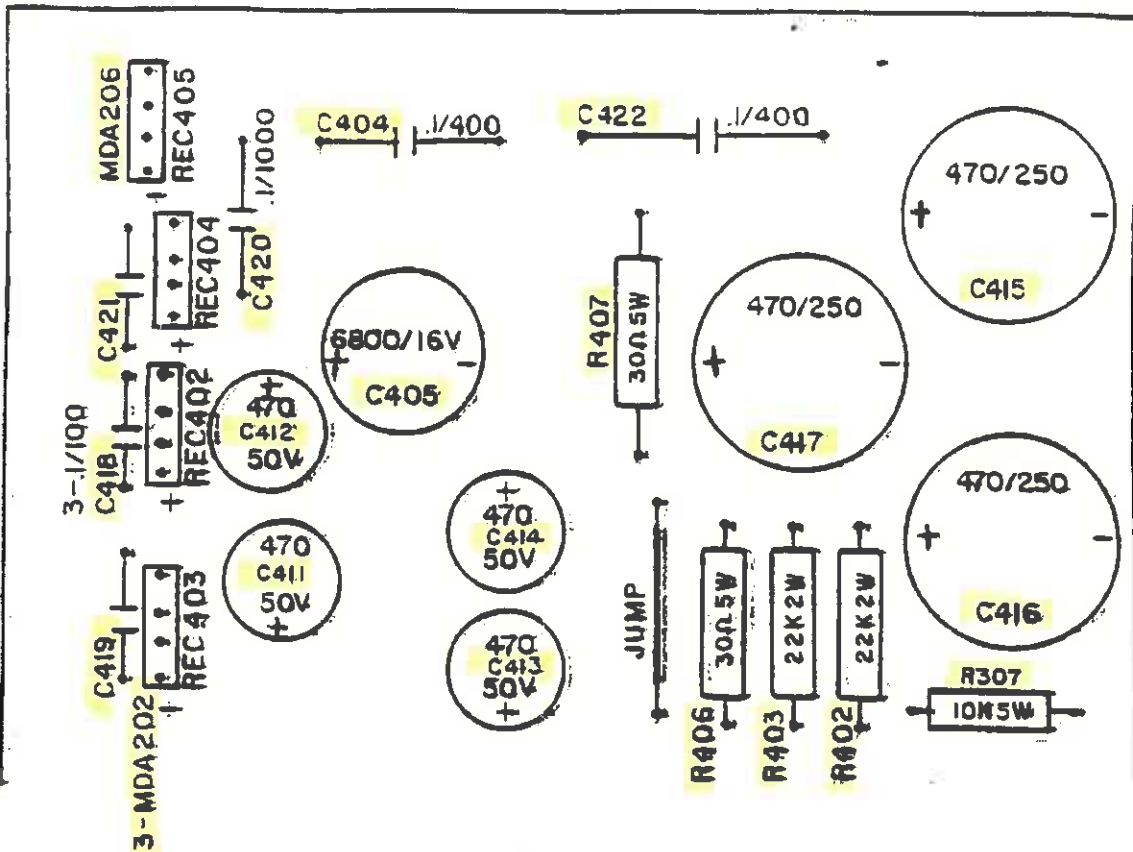

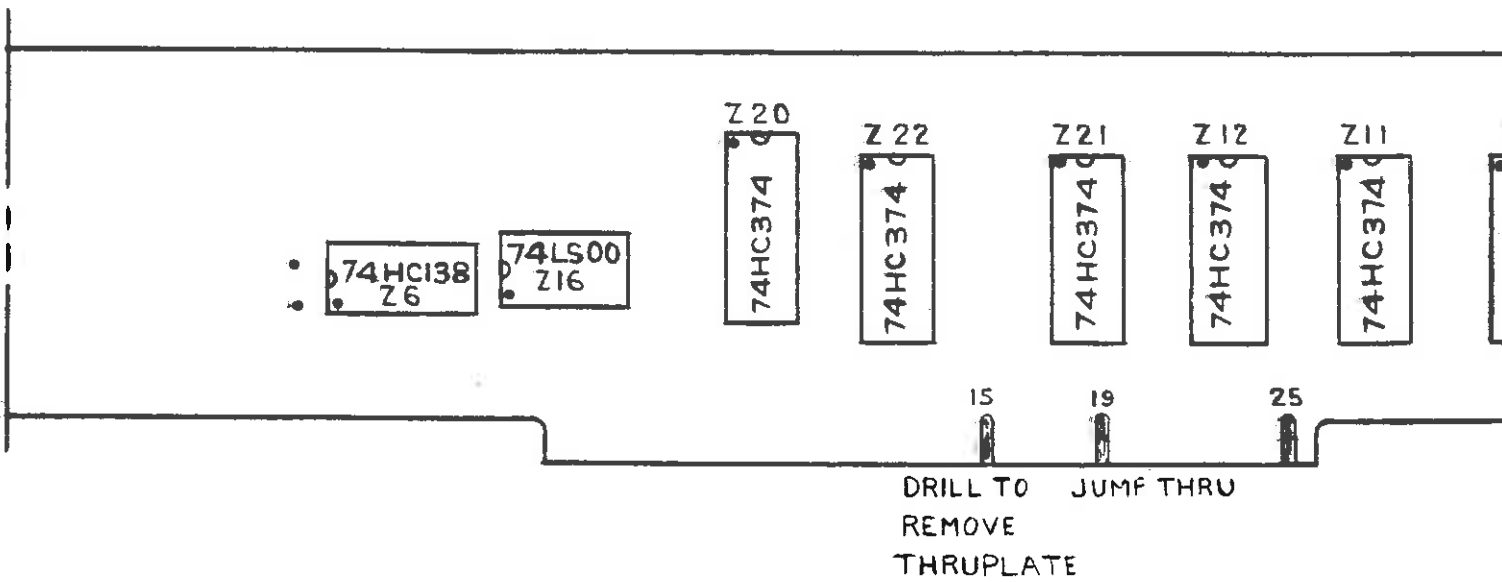
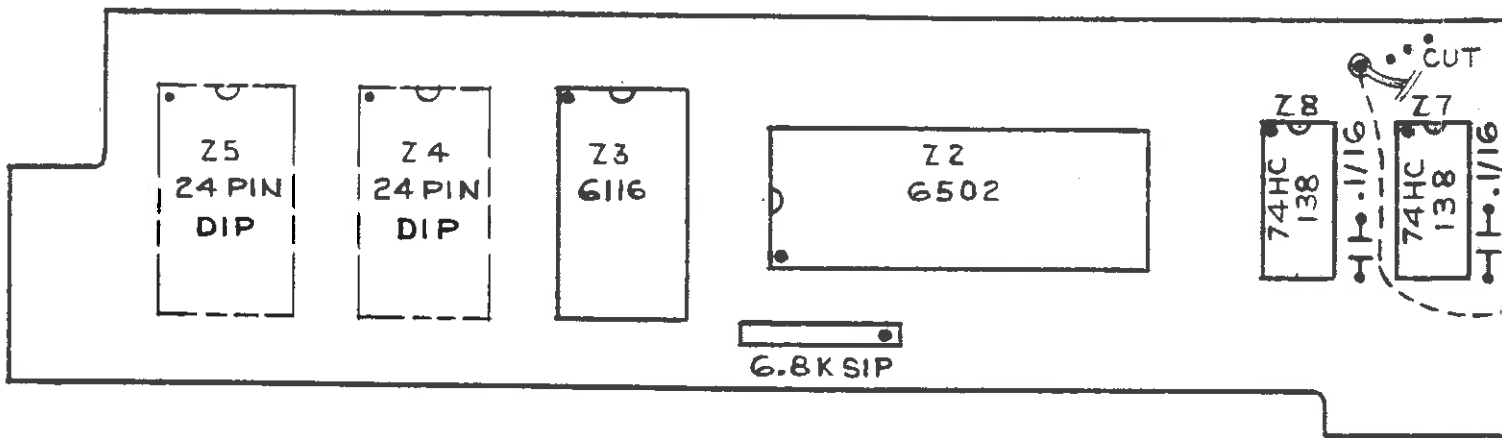

100V "0" R23

AMP "0" R17

2SD R14 3SD R15

4SD R16 866K 10V FS R13

DAC "0" R12

- R10 10V
- R9 9V
- R8 8V
- R7 7V
- R6 6V
- R5 5V
- R4 4V
- R3 3V
- R2 2V
- R1 1V

REFER ANODE T.P.

R1 FACTO

EDC 4013/14C