

2015-75 Upconverter, 250 - 750 MHz

The 2015-75 Upconverter converts 70 ± 18 MHz to 250 to 750 MHz in 1 MHz steps with low group delay and flat frequency response. Synthesized local oscillators (LO) provide frequency selection. Multi-function push button switches select the RF frequency, gain, and other parameters. Front panel LEDs provide indication of DC power (green), PLL alarm (red), remote operation (yellow) or the TX carrier is muted (yellow). Variable attenuators for the IF input and output provide a gain range of -10 to +30 dB as adjusted by the front panel multi-function pushbutton switches. Remote operation allows selection of frequency and gain. Parameter selection and frequency and gain settings appear on the LCD display. Connectors are BNC (female) for IF and optional external 10MHz reference input and output, and Type F (female) for the RF output. The unit is powered by a 100-240 $\pm 10\%$ VAC power supply, and housed in a 1 3/4" X 19" X 16" rack mount chassis.

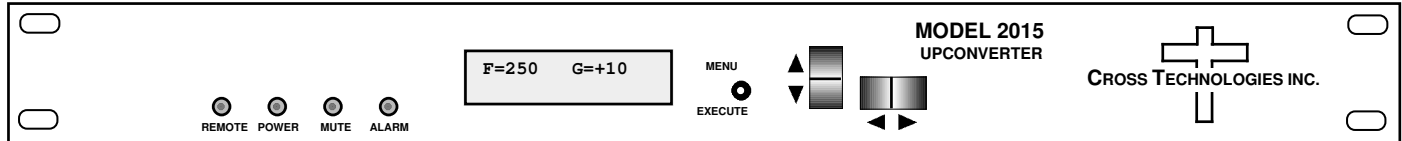

Front Panel

EQUIPMENT SPECIFICATIONS*

Input Characteristics

Impedance	75 Ω
Return Loss	18 dB
Frequency	70 ± 18 MHz
Input Level	-40 to -10 dBm

Output Characteristics

Impedance	75 Ω
Return Loss	10 dB
Frequency	250 to 750 MHz
Output level	0 to -20 dBm
Output 1 dB compression	+5 dBm

Channel Characteristics

Gain range (adjustable)	-10.0 to 30.0 dB
Spurious Response	< -50 dBC
2nd Harmonic	< 40 dB
Frequency Response	± 1.5 dB, 250-750 MHz; ± 0.5 dB, 36 MHz BW
Group Delay, max	0.01 ns/MHz ² parabolic; 0.03ns/MHz linear; 1 ns ripple
Frequency Sense	Non-inverting

Synthesizer Characteristics

Frequency Accuracy	± 1.0 ppm max over temp (± 0.01 ppm, opt-H) internal ref.
Frequency Step	1.0 MHz minimum
External 10 MHz level	+3 dBm ± 3 dB, 50/75 Ω (opt-E)

Phase Noise @ Freq	100 Hz	1kHz	10kHz	100kHz	1 MHz
dBC/Hz	-70	-70	-80	-95	-105

Controls, Indicators

Frequency Selection	Direct readout LCD; pushbutton switches or remote selection
Gain Selection	Direct readout LCD; pushbutton switches or remote selection
Pwr; Alm; Remote; Mute	Green LED; Red LED; Yellow LED; Yellow LED
Remote	RS232C, 9600 baud (RS422/485/ Option-Q , Ethernet/ Option -W8; -W18; -W28)

Other

RF Connector	Type F (female)
IF, 10 MHz Connectors	BNC (female)
Alarm/Remote Connector	DB9 (female) - NO or NC contact closure on Alarm
Size	19 inch, 1RU standard chassis 1.75"high X 16.0" deep
Power	100-240 $\pm 10\%$ VAC, 47-63 Hz, 45 watts max

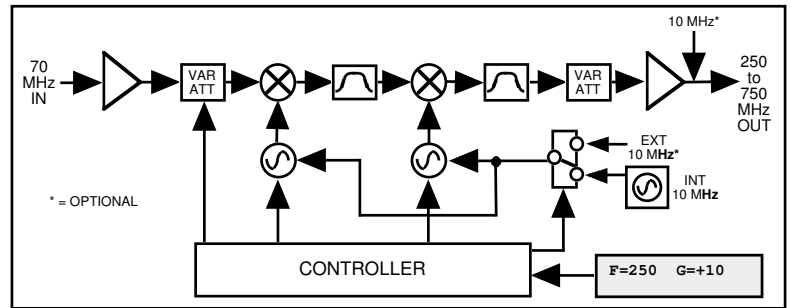

Block Diagram

Available Options

- E - External 10 MHz ref input & output w/ RF insertion
- H - High Stability (± 0.01 ppm) Int. Ref
- Q - RS485 Remote Interface
- Z - Attenuator 0.1 dB on Upconverter
- W8 - Ethernet; w/Web Browser (WB)**
- W18 - Ethernet; w/WB & SNMP**
- W28 - Ethernet; w/TCP/IP, Telnet®**
- W17 - IF Test/Monitor Ports**
- Connectors/Impedance**
- B - 75 Ω BNC (RF), 75 Ω BNC (IF)
- C - 50 Ω BNC (RF), 75 Ω BNC (IF)
- D - 50 Ω BNC (RF), 50 Ω BNC (IF)
- N - 50 Ω N-type (RF), 75 Ω BNC (IF)
- M - 50 Ω N-type (RF), 50 Ω BNC (IF)
- S - 50 Ω SMA (RF), 50 Ω BNC (IF)**

*10°C to 40°C; Specifications subject to change without notice