

## Features

- Frequency range of 150 kHz to 30 MHz
- Fully compliant with CISPR 16-1-2 / ANSI C63.4
- “Air-core” inductors to prevent saturation
- Individual Calibration Included
- Three-Year Warranty



## Description

The LI-125C Line Impedance Stabilization Network (LISN) provides the necessary measurement platform for performing power line conducted emissions compliance testing as required by most worldwide standards for commercial products. The LI-125C is compliant with both CISPR 16-1-2 and ANSI C63.4.

The LISN provides defined stable impedance and isolates the EUT from power source influences, thereby providing accurate and repeatable results.

The LI-125C includes one pair of, separately housed, single-conductor networks, to be installed in series with each current-carrying conductor in a single-phase, dual-phase or DC power system. A second LI-125C pair can be used to accommodate 3-phase power systems (Wye or Delta configurations).

The LI-125C is equipped with Superior Electric SUPERCON® shrouded sockets at the mains (power input) and EUT (power output) ports. The matching color-coded plugs for connection to the mains and EUT wiring are included.

This LISN uses air-core inductors to prevent saturation and permeability variation. The mounting plate of the LI-125C is left unpainted in order to facilitate connection to earth ground in its installation, which is essential due to high leakage current.

## Transient Protection

Use of a Transient Limiter for impedance matching, reduction of out-of-band emissions and transient protection for your measurement instrument is highly recommended and available from Com-Power.

## Calibration

All Com-Power LISNs are individually calibrated in compliance with the relevant requirements of CISPR 16-1-2 and ANSI C63.4. Impedance, Phase, Isolation, and Insertion Loss data is supplied with each unit, along with the calibration certificate.

## Typical Connection Diagrams

### Single Phase connection with one set of LISN

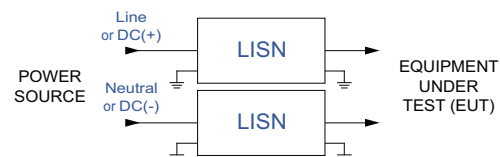

### Three Phase connection with two sets of LISNs

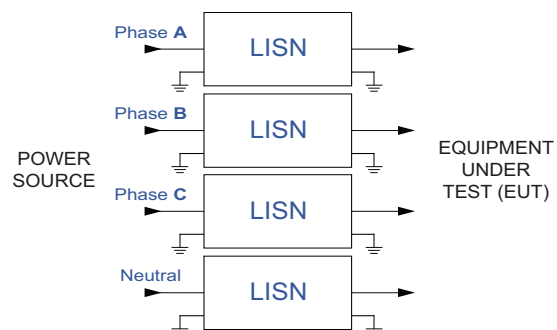

## Application

<b>Product Name</b>	Line Impedance Stabilization Network (LISN)
<b>Specification</b>	CISPR 16-1-2 / ANSI C63.4
<b>Application</b>	Power line conducted emissions tests
<b>Frequency Range</b>	150 kHz to 30 MHz
<b>RF Connector</b>	50Ω N-type (female)
<b>Current Rating</b>	25 Amperes <sub>(AC)</sub> , 17 Amperes <sub>(DC)</sub>
<b>Voltage Rating</b>	270 VAC (Line to Ground) 50-60 Hz, 380 VDC
<b>Inductors</b>	50 μH (air-core)
<b>Mains &amp; EUT Connections</b>	Superior Electric <b>SUPERCON</b> ® shrouded sockets
<b>Dimensions (each network)</b>	13 x 7 x 7 inches / 33 x 17.7 x 17.7 cm
<b>Weight (each network)</b>	6 lbs. / 2.7 kg
<b>Insertion Loss</b>	< 0.5 dB (150 kHz to 30 MHz)
<b>Isolation</b>	> 40 dB (150 kHz to 30 MHz)

All specifications are subject to change without notice.  
All values are typical, unless specified.

