



## Horn Antenna AH-840

### Features

**Broadband** - 18 GHz to 40 GHz

**High gain**

**Individual calibration**

**Two year warranty**



### Description

Model AH-840 is a broadband linearly polarized double ridged waveguide horn antenna designed specifically for Electromagnetic Interference testing. This antenna can be used for receiving as well as transmitting applications for the frequency range of 18 GHz to 40 GHz.

This antenna has a high gain; least 20 dBi over the entire frequency range. This antenna can accept up to 5 Watts of input power at its terminals in continuous mode for generating electromagnetic fields for immunity testing.

The AH-840 Horn antenna has a K type connector which can mate with SMA type connectors. The antenna is constructed using lightweight aluminum with corrosion resistant finish. The oval rear plate has a 1/4" x 20 threaded hole for mounting it to Com-Power AT-100 tripod.

The antenna is individually calibrated at 1 meter and data and certificate of calibration will be shipped with the antenna. The data will include the antenna factor and gain of the antenna.

### Application

The AH-840 was designed for EMC testing, but it can also be used for antenna gain pattern measurements, surveillance, and other applications. The wide frequency band makes the AH-840 antenna suitable for sweep measurements, reducing the need for antenna switching during the tests.

High gain reduces the input power requirement to achieve the desired field levels for immunity testing and improves antenna sensitivity to low level signals. During emissions testing the measured field strength can be calculated by adding the antenna factor for the particular frequency to voltage measured at the antenna output terminal.

For immunity measurements, the input power requirement **P** in Watts to generate **E** Electric Field Strength in V/m at a distance **D** in meters can be calculated by using the following formula:

$$P = E^2 \times D^2 / 30 \times N$$

$$N = 10^{(G/10)}$$

$$G = 20 \log F - 29.79 - AF$$

Where

**N** = Numeric Gain

**G** = gain in dBi

**F** = Frequency in MHz

**AF** = antenna factor in dB/m

## Specifications

Frequency Range: 18 GHz - 40 GHz  
 Power handling: 5 Watts CW  
 VSWR: 2.0 :1.0  
 Connector type: K type female  
 Polarization: Linear  
 Impedance: 50 Ohms  
 Weight: 2 lbs. max. (0.9 kg)  
 Size (L xW xH): 8.7 x 2.7 x 7.5" inches  
 22 x 6.8 x 19.0 cm

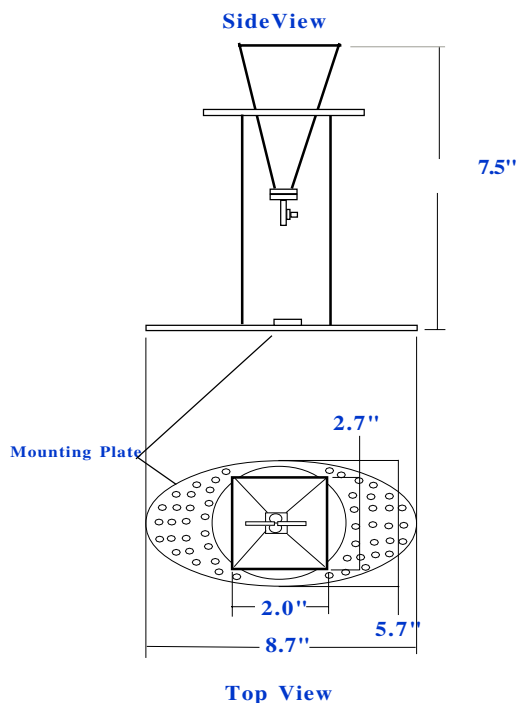

### Typical Antenna Factors:

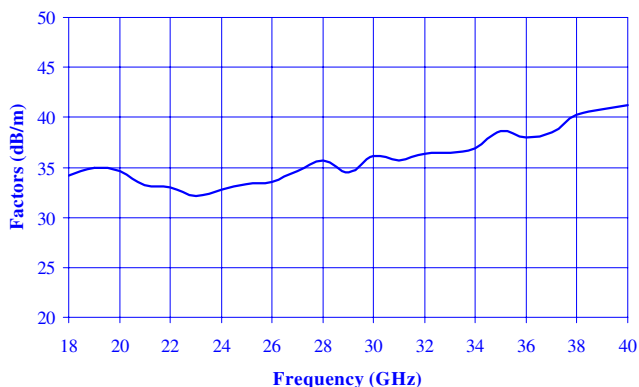

$$\text{Field strength (dBV/m)} = \text{Output measured (dBV)} + \text{Antenna Factor (dB/m)}$$

Typical Antenna Gain & Power requirement in Watts at a one meter distance to obtain field strength in V/m:

Freq. GHz	Gain (dBi)	Freq. GHz	Field Strength		
			V/m 10	V/m 20	V/m 100
18	21.12	18	0.03	0.10	2.58
19	20.79	19	0.03	0.11	2.78
20	21.63	20	0.02	0.09	2.29
22	24.06	22	0.01	0.05	1.31
24	25.01	24	0.01	0.04	1.05
26	25.01	26	0.01	0.04	1.05
28	23.45	28	0.02	0.06	1.51
30	23.65	30	0.01	0.06	1.44
32	23.91	32	0.01	0.05	1.35
34	23.94	34	0.01	0.05	1.35
36	23.34	36	0.02	0.06	1.55
38	21.61	38	0.02	0.09	2.30
40	21.05	40	0.03	0.10	2.62

All values are typical values unless specified.  
 Dimensions are given in inches unless specified  
 Last update: 1/02