



## Horn Antenna AH-826

### Features

**Broadband** - 18 GHz to 26.5 GHz

**High Gain** - Lower Floor Noise for Emissions

**Individual Calibration**

**Two Year Warranty**



### Description

Model AH-826 is a broadband linearly polarized double ridged waveguide horn antenna designed specifically for Electromagnetic Interference testing. This antenna can be used for receive as well as transmit applications for the frequency range of 18 GHz to 26.5 GHz.

This antenna has high gain, with at least 23 dBi over the entire frequency range. This antenna can accept up to 5 Watts of input power at its terminals in continuous mode in the applicable frequency range for generating electromagnetic fields for immunity testing.

The AH-826 Horn antenna has a K type connector which can mate with SMA type connector. The antenna is constructed using lightweight aluminum with a corrosion resistant finish. The oval rear plate has a 1/4" x 20 threaded hole for mounting it to the Com-Power AT-100 tripod.

The antenna is individually calibrated. The data and certificate of calibration will be shipped with the antenna. The data will include the antenna factors and antenna gain.

### Application

The AH-826 was designed for EMC testing, but can also be used for antenna gain pattern measurements, surveillance, and other applications. The wide frequency band makes the AH-826 antenna suitable for sweep measurement, reducing the need for antenna switching during the test.

High gain reduces input power requirements to achieve the desired field strength levels for immunity testing and improves antenna sensitivity to low level signals during emissions testing. The measured field strength can be calculated by adding the antenna factor for the particular frequency to voltage measured at the antenna output terminal.

For immunity measurements, the input power requirement **P** in Watts to generate **E** electric field strength in V/m at a distance **D** in meters can be calculated by using the following formula:

$$P = E^2 \times D^2 / 30 \times N$$

$$N = 10^{(G/10)}$$

$$G = 20 \log F - 29.79 - AF$$

Where

**N** = Numeric Gain

**G** = gain in dBi

**F** = Frequency in MHz

**AF** = antenna factor in dB/m

## Specifications

**Frequency Range:** 18 GHz - 26.5 GHz  
**Power handling:** 5 Watts CW  
**VSWR:** 2.0 :1.0  
**Polorization:** Linear  
**Connector type:** K type (will mate with SMA)  
**Impedance:** 50 Ohms  
**Weight:** 1.5 lbs. (0.68 kg) max.  
**Size (L x W x H):** 8.7 x 5.7 x 12 inches max.  
 22 x 14.5 x 30.5 cm max.

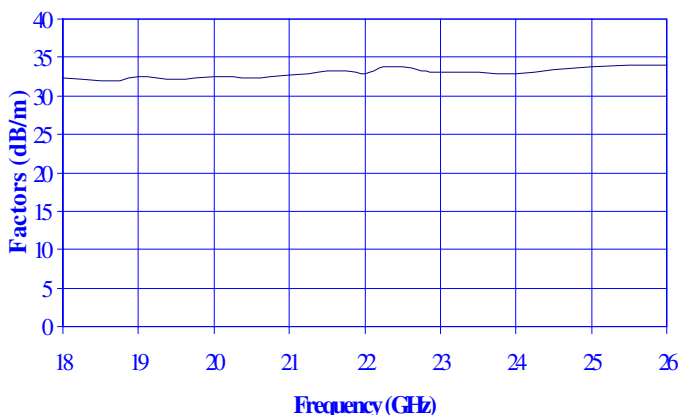
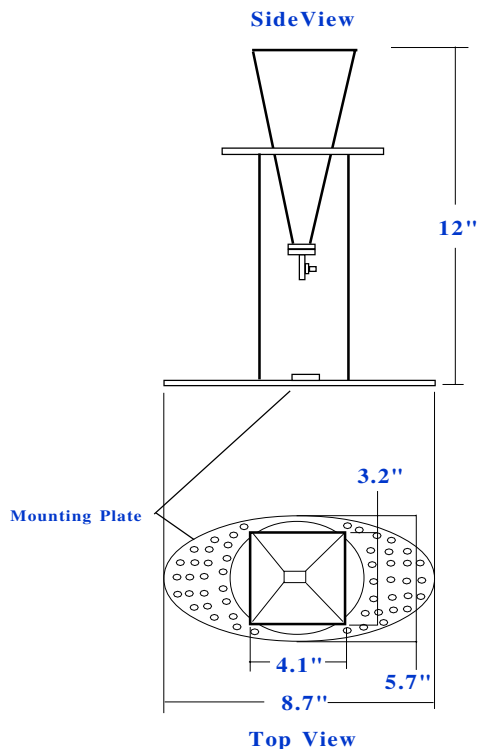

$$\text{Field strength (dBV/m)} = \text{Output measured (dBV)} + \text{Antenna Factor (dB/m)}$$

Typical Antenna Gain & Power requirement in Watts at a one meter distance to obtain field strength in V/m:

Freq. GHz	Gain (dBi)	Freq. GHz	Field Strength		
			V/m 10	V/m 20	V/m 100
18	23.02	18	0.02	0.07	1.66
19	23.29	19	0.02	0.06	1.56
20	23.73	20	0.01	0.06	1.41
21	23.95	21	0.01	0.05	1.34
22	24.16	22	0.01	0.05	1.28
23	24.34	23	0.01	0.05	1.23
24	24.91	24	0.01	0.04	1.08
25	24.37	25	0.01	0.05	1.22
26.5	24.51	26.5	0.01	0.05	1.18

All values are typical values unless specified.  
 All specifications are subject to change without notice.  
 Last update: 1/02