

## Features

**Broadband** - For sweep measurements

**High Gain** - Lower Floor Noise for Emissions

**Two year warranty**

**Individual calibration**



## Description

The Horn antenna Model AH-118 is a standard broadband double ridged waveguide horn antenna. This antenna is linearly polarized and is designed specifically for EMC measurements for the 1-18 GHz frequency range.

The AH-118 Horn antenna can be used for emissions and immunity testing. The gain of this Horn antenna is at least 6.1 dBi over the entire frequency range. Model AH-118 can accept up to 300 Watts input power in continuous mode.

This antenna is constructed using light weight aluminum with a corrosion resistant conductive coating. The mounting base of Model AH-118 has 1/4 inch x 20 threads. This allows the antenna to be mounted on a tripod (Model AT-100) or a tripod with matching threads.

Each antenna is individually calibrated at 3 meters. The calibration data and certificate will be shipped with each antenna.

## Application

This antenna is suitable for ANSI 63.4, CISPR16, EN 55022, FAA and other EMC standards that require emissions and immunity testing.

The high gain reduces input power requirements to generate high electromagnetic field levels for immunity testing. High gain also increases antenna sensitivity to low level signals.

During emissions measurement, the field strength (dBV/m) is calculated by adding the antenna factor (dB/m) to the voltage measured (dBV) at the antenna terminals.

For immunity testing, the input power requirement **P** in Watts to generate **E** Electric Field Strength in V/m at a distance in **D** meters can be calculated by using the following formula:

$$P = E^2 \times D^2 / 30 \times \text{Numeric Gain}$$

$$G = 20 \log F - 29.79 - AF$$

$$G = 10 \log (\text{Numeric Gain})$$

*Where*

G= gain in dBi

F = Frequency in MHz

AF = antenna factor in dB

# Specifications

Frequency Range: 1 GHz - 18 GHz  
 Input Power: 300 Watts continuous  
 VSWR: 2.0 : 1  
 Polarization: Linear  
 Impedance: 50 Ohm  
 Connector type: N Female  
 Weight: 4 lb. max.  
 Size: 7.8" X 9.5" X 5.6" max.

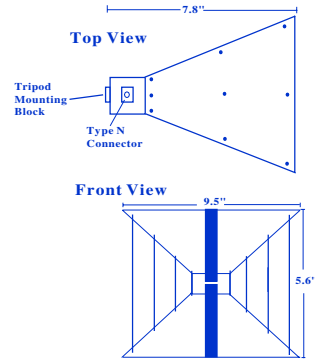

## Typical Antenna Factors:

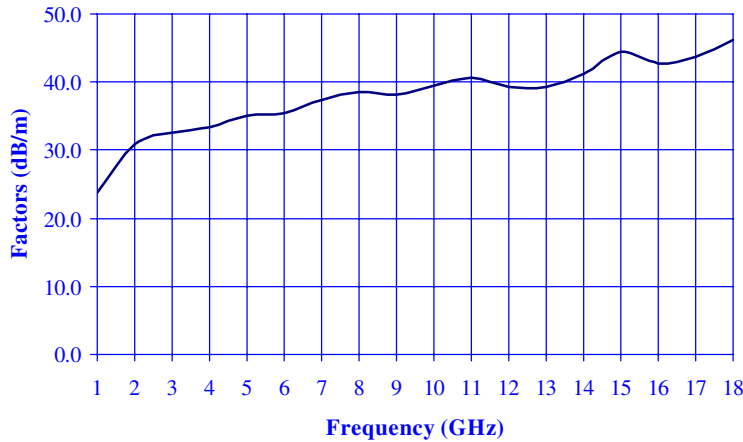

**Field strength (dBV/m) = Output measured (dBV) + Antenna Factor (dB/m)**

## Typical Antenna Gain and Power Requirement at 1 meter antenna spacing:

Freq. GHz	Gain dBi	Power requirement (Watts)		
		10V/m	20 V/m	100 V/m
1	6.4	0.8	3.0	76.2
2	5.3	1.0	3.9	97.7
3	7.2	0.6	2.6	64.2
4	8.9	0.4	1.7	43.4
5	9.1	0.4	1.6	41.1
6	10.4	0.3	1.2	30.6
7	9.7	0.4	1.4	35.6
8	9.8	0.4	1.4	35.1
9	11.1	0.3	1.0	25.9
10	10.7	0.3	1.1	28.3
12	12.5	0.2	0.8	18.8
14	11.9	0.2	0.9	21.4
16	11.5	0.2	0.9	23.6
18	9.2	0.4	1.6	39.9

All values are typical values unless specified.  
 All specifications are subject to change without notice.