

**Chroma**

**Programmable  
AC Source  
61705  
User's Manual**

Version 1.2  
March 2007  
P/N A11 000906

# Legal Notices

The information in this document is subject to change without notice.

Chroma ATE INC. makes no warranty of any kind with regard to this manual, including, but not limited to, the implied warranties of merchantability and fitness for a particular purpose. Chroma ATE INC. shall not be held liable for errors contained herein or direct, indirect, special, incidental or consequential damages in connection with the furnishing, performance, or use of this material.

## **CHROMA ATE INC.**

66 Hwa-Ya 1st Rd., Hwa-Ya Technical Park, Kuei-Shan Hsiang, Taoyuan Hsien, Taiwan

Copyright Notices. Copyright 2003-2007 Chroma ATE INC., all rights reserved.  
Reproduction, adaptation, or translation of this document without prior written permission is prohibited, except as allowed under the copyright laws.

# Warranty

All Chroma instruments are warranted against defects in material and workmanship for a period of one year after date of shipment. Chroma agrees to repair or replace any assembly or component found to be defective, under normal use during this period. Chroma's obligation under this warranty is limited solely to repairing any such instrument which in Chroma's sole opinion proves to be defective within the scope of the warranty when returned to the factory or to an authorized service center. Transportation to the factory or service center is to be prepaid by the purchaser. Shipment should not be made without prior authorization by Chroma.

This warranty does not apply to any products repaired or altered by persons not authorized by Chroma, or not in accordance with instructions furnished by Chroma. If the instrument is defective as a result of misuse, improper repair, or abnormal conditions or operations, repairs will be billed at cost.

Chroma assumes no responsibility for its product being used in a hazardous or dangerous manner either alone or in conjunction with other equipment. High voltage used in some instruments may be dangerous if misused. Special disclaimers apply to these instruments. Chroma assumes no liability for secondary charges or consequential damages and in any event, Chroma's liability for breach of warranty under any contract or otherwise, shall not exceed the purchase price of the specific instrument shipped and against which a claim is made.

Any recommendations made by Chroma for use of its products are based upon tests believed to be reliable, but Chroma makes no warranty of the results to be obtained. This warranty is in lieu of all other warranties, expressed or implied, and no representative or person is authorized to represent or assume for Chroma any liability in connection with the sale of our products other than set forth herein.

## **CHROMA ATE INC.**

66 Hwa-Ya 1st Rd., Hwa-Ya Technical Park,

Kuei-Shan Hsiang, Taoyuan Hsien, Taiwan

Tel: 886-3-327-9999

Fax: 886-3-327-2886

<http://www.chromaate.com>

# Material Contents Declaration

A regulatory requirement of The People's Republic of China defined by specification SJ/T 11364-2006 mandates that manufacturers provide material contents declaration of electronic products, and for Chroma products are as below:

Part Name	Hazardous Substances					
	Lead	Mercury	Cadmium	Hexavalent Chromium	Polybrominated Biphenyls	Polybromodiphenyl Ethers
	Pb	Hg	Cd	Cr <sup>6+</sup>	PBB	PBDE
PCBA	×	○	○	○	○	○
CHASSIS	×	○	○	○	○	○
ACCESSORY	×	○	○	○	○	○
PACKAGE	○	○	○	○	○	○

“○” indicates that the level of the specified chemical substance is less than the threshold level specified in the standards of SJ/T-11363-2006 and EU 2005/618/EC.

“×” indicates that the level of the specified chemical substance exceeds the threshold level specified in the standards of SJ/T-11363-2006 and EU 2005/618/EC.

1. Chroma is not fully transitioned to lead-free solder assembly at this moment; however, most of the components used are RoHS compliant.
2. The environment-friendly usage period of the product is assumed under the operating environment specified in each product's specification.

## Disposal

Do not dispose of electrical appliances as unsorted municipal waste, use separate collection facilities. Contact your local government for information regarding the collection systems available. If electrical appliances are disposed of in landfills or dumps, hazardous substances can leak into the groundwater and get into the food chain, damaging your health and well-being. When replacing old appliances with new one, the retailer is legally obligated to take back your old appliances for disposal at least for free of charge.



## CE-Conformity Declaration

For the following equipment:

Product Name: Programmable AC Source

Model Name: 61705

Manufacturer's Name: Chroma ATE Inc.

Manufacturer's Address: 66 Hwa-Ya 1st Rd., Hwa-Ya Technical Park,  
Kuei-Shan Hsiang, Taoyuan Hsien, Taiwan

is herewith confirmed to comply with the requirements set out in the Council Directive on the Approximation of the Laws of the Member States Relating to Electromagnetic Compatibility (89/336/EEC) and electrical equipment designed for use within certain voltage limits (73/23/EEC;93/68/EEC)

For electromagnetic compatibility, the following standards were applied:

EMC:           EN61326 : 1998/A2 : 2002  
                  EN55011 : 1998/A1 : 1999(Group 1, Class A)  
                  IEC 61000-4-2 : 1995/A1 : 1998/A2 : 2000  
                  IEC 61000-4-3 : 1996/A1 : 1998/A2 : 2000  
                  IEC 61000-4-4 : 1995/A1 : 2000  
                  IEC 61000-4-5 : 1995/A1 : 2000  
                  IEC 61000-4-5 : 1996/A1 : 2000

For safety requirement, the following standard was applied:

Safety:        EN61010-1(1993)+A2(1995)

Taiwan            August, 2005  
Place             Date

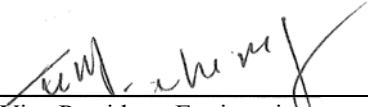
  
\_\_\_\_\_  
Vice President, Engineering

### **Warning:**

**This is a class A product. In a domestic environment this product may cause radio interference in which case the user may be required to take adequate measures.**

# Safety Summary

The following general safety precautions must be observed during all phases of operation, service, and repair of this instrument. Failure to comply with these precautions or specific WARNINGS given elsewhere in this manual will violate safety standards of design, manufacture, and intended use of the instrument.

*Chroma* assumes no liability for the customer's failure to comply with these requirements.

## **BEFORE APPLYING POWER**

Verify that the product is set to match with the line voltage.

## **PROTECTIVE GROUNDING**

Make sure to connect the protective grounding to prevent an electric shock before turning on the power.

## **NECESSITY OF PROTECTIVE GROUNDING**

Never cut off the internal or external protective grounding wire, or disconnect the wiring of protective grounding terminal. Doing so will cause a potential shock hazard that may bring injury to a person.

## **FUSES**

Only fuses with the required rated current, voltage, and specified type (normal blow, time delay, etc.) can be used. Do not use different fuses or short-circuited fuseholders. To do so might cause a shock or fire hazard.

## **DO NOT OPERATE IN AN EXPLOSIVE ATMOSPHERE**



Do not operate the instrument in the presence of flammable gases or fumes.

## **DO NOT REMOVE THE COVER OF THE INSTRUMENT**

Operating personnel must not remove the cover of the instrument. Only qualified service personnel can do component replacement and internal adjustment.

<p><b>WARNING</b> <i>LETHAL VOLTAGES. AC Sources can supply 426 V peak at their output. DEATH on contact may result if the output terminals or circuits connected to the output are touched when power is applied.</i></p>
--

# Safety Symbols

	<b>DANGER</b> – High voltage.
	<b>Explanation:</b> To avoid injury, death of personnel, or damage to the instrument, the operator must refer to an explanation in the instruction manual.
	<b>Protective grounding terminal:</b> To protect against electrical shock in case of a fault. This symbol indicates that the terminal must be connected to ground before operation of equipment.
<b>WARNING</b>	A <b>WARNING</b> sign denotes a hazard. It calls attention to a procedure, practice, condition or the like which may result in injury or death of personnel if it is not rightly observed.

## ACOUSTIC NOISE INFORMATION

This product has a sound pressure emission (at the operator's side) < 65dB(A).

## **Revision History**

The following lists the additions, deletions and modifications in this manual at each revision.

<b>Date</b>	<b>Version</b>	<b>Revised Sections</b>
Oct. 2003	1.0	Complete this manual
Aug. 2005	1.1	Change the address and phone no. of Chroma ATE Inc.
Mar. 2007	1.2	Add " <i>Material Contents Declaration</i> ".



# Table of Contents

<b>1.</b>	<b>General Information.....</b>	<b>1-1</b>
1.1	Introduction .....	1-1
1.2	Key Features.....	1-1
1.3	Specifications .....	1-1
1.4	Names of Parts .....	1-4
1.4.1	The Front Panel .....	1-4
1.4.2	The Rear Panel .....	1-6
<b>2.</b>	<b>Installation.....</b>	<b>2-1</b>
2.1	Inspection .....	2-1
2.2	Preparation for Use.....	2-1
2.3	Requirements of Input Power.....	2-1
2.3.1	Ratings.....	2-1
2.3.2	Input Connection .....	2-1
2.4	Output Connection .....	2-4
2.5	Remote Sense Connection.....	2-4
2.6	Power-On Procedures.....	2-5
2.7	I/O Connectors (Option).....	2-7
<b>3.</b>	<b>Local Operation .....</b>	<b>3-1</b>
3.1	Introduction .....	3-1
3.2	Operation through Keypad and RPG .....	3-1
3.3	MAIN PAGE (Output Setting and Measurement) .....	3-5
3.4	CHOICE PAGE (Functional List Choice) .....	3-6
3.5	SETUP Functional List .....	3-7
3.5.1	RANGE .....	3-7
3.5.2	Vac LIMIT .....	3-8
3.5.3	Vdc LIMIT (+), Vdc LIMIT (-) .....	3-8
3.5.4	I LIMIT, DELAY .....	3-9
3.5.5	OUTPUT RELAY.....	3-10
3.5.6	BUZZER .....	3-10
3.5.7	DATA LOCK.....	3-10
3.5.8	Is START, Is INTERVAL .....	3-11
3.6	CONF Functional List.....	3-11
3.6.1	REMOTE INHIBIT.....	3-12
3.6.2	EXT. V, COUPLE (Reserved).....	3-13
3.6.3	WAVEFORM GENERATOR .....	3-15
3.6.4	GPIB Address, RS-232C.....	3-16
3.6.5	POWER ON STATUS .....	3-16
3.7	OUTPUT Functional List.....	3-17
3.7.1	V_SET .....	3-18
3.7.2	Output Degree .....	3-18
3.7.3	Vdc Output .....	3-19
3.7.4	Phase Angle Setting .....	3-19
3.7.5	Slew Rate of Output Transient .....	3-20
3.8	Save and Recall .....	3-21
3.8.1	Save and Recall Output Setting.....	3-21
3.8.2	Save and Recall System Data.....	3-22

3.9	Protection .....	3-23
<b>4.</b>	<b>Calibration.....</b>	<b>4-1</b>
4.1	Introduction .....	4-1
4.2	MANUAL CALI Functional List.....	4-2
4.2.1	Output Voltage and Voltage Measurement Calibration.....	4-3
4.2.2	Current Measurement Calibration.....	4-5
4.2.3	External Vref Calibration (Reserved) .....	4-6
4.2.4	Phase Angle Calibration.....	4-8
<b>5.</b>	<b>Application .....</b>	<b>5-1</b>
5.1	General .....	5-1
5.2	List Mode (Optional Function) .....	5-1
5.3	Pulse Mode (Optional Function).....	5-6
5.4	Step Mode (Optional Function).....	5-8
5.5	Interharmonics Waveform (Optional Function).....	5-11
<b>6.</b>	<b>Theory of Operation .....</b>	<b>6-1</b>
6.1	Description of Overall System .....	6-1
6.2	Description of Power Transfer Unit.....	6-1
<b>7.</b>	<b>Self-test and Troubleshooting.....</b>	<b>7-1</b>
7.1	General .....	7-1
7.2	Self-test.....	7-1
7.3	Troubleshooting .....	7-2
<b>8.</b>	<b>Remote Operation.....</b>	<b>8-1</b>
8.1	General Information .....	8-1
8.1.1	Setting the GPIB Address and RS-232C Parameters.....	8-1
8.1.2	Wire Connection of RS-232C .....	8-1
8.2	The GPIB Capability of the AC Source .....	8-2
8.3	Introduction to Programming .....	8-3
8.3.1	Conventions.....	8-3
8.3.2	Numerical Data Formats .....	8-3
8.3.3	Boolean Data Format .....	8-3
8.3.4	Character Data Format .....	8-3
8.3.5	Basic Definition.....	8-4
8.4	Traversal of the Command Tree.....	8-5
8.5	The Execution Order .....	8-5
8.6	The Commands of the AC Source.....	8-6
8.6.1	Common Command Dictionary .....	8-6
8.6.2	Instrument Command Dictionary.....	8-8
8.7	Command Summary.....	8-30
<b>Appendix A</b>	<b>Pin Assignment of TTL Signal.....</b>	<b>A-1</b>
<b>Appendix B</b>	<b>Built-in Waveforms.....</b>	<b>B-1</b>

# 1. General Information

## 1.1 Introduction

The Chroma AC Source 61705 is a high efficiency, 3-phase AC power source which provides sine wave output with low distortion, and accurate measurement of power. The DSP microprocessor generates accurate, stable output voltage and frequency. The PWM design of power stage allows for full volt-ampere into loads. The front panel has both RPG (rotary pulse generator) and keypad controls for setting the output voltage and frequency. The LCD provides a complete operating state of the unit to the user. Remote programming is accomplished either through the GPIB bus or the RS-232C serial port.

## 1.2 Key Features

### A. Configuration

- Local operation from the keypad on the front panel.
- Remote operation via GPIB or RS-232C interface.
- Protection against Over-power, Over-current, Over-temperature and Fan-fail.
- Temperature controlled fan speed.
- Built-in output isolation relays.

### B. Input/Output

- Selective output voltage (Neutral to Line) with full scale of 150V/300V.
- Input voltage range 61705: 190 ~ 250Vac.
- Measurement of V, I, P, CF and PF.
- Remotely inhibited control.
- AC ON/OFF output signal.

## 1.3 Specifications

The operation specifications of the model 61705 are listed below. All specifications have been tested according to the standard test procedures of Chroma, and are based on a remote sense connection,  $25 \pm 1^{\circ}\text{C}$ , and resistor load unless specified otherwise.

<b>Model</b>	<b>61705</b>
<b>AC OUTPUT RATING</b>	
Max. Power	12000 VA
Power Per Phase	4K VA
<b>Voltage</b>	
Range	150V / 300V
Output Voltage	0~150V/0~300V, 0~140V/0~280V@>1000Hz
Accuracy	0.2%+0.2%F.S.
Resolution	0.1 V
Distortion	0.3% @50/60Hz 1.5%15- 1.2KHz
Line Regulation	0.1%
Load Regulation	0.2%
Temp. Coefficient	0.02% per degree from 25°C
<b>Max. Current (per phase)</b>	
R.M.S.	32A / 16A
Peak	192A / 96A
<b>Frequency</b>	
Range	DC, 15-1.2K Hz
Accuracy	0.15%
<b>Phase</b>	
Range	0 ~ 360°
Resolution	0.3°
Accuracy	<0.8°@50/60Hz
<b>DC OUTPUT RATING (per phase)</b>	
Power	2K W
Voltage	212V / 424V
Current	16A / 8A
<b>INPUT 3-PHASE AC POWER (per phase)</b>	
Voltage range	190-250V
Frequency range	47-63 Hz
Current	28A Max.
Power Factor	0.98 Min.
<b>MEASUREMENT</b>	
<b>Voltage</b>	
Range	150V / 300V
Accuracy	0.2%+0.2%F.S.
Resolution	0.1 V
<b>Current</b>	
Range (peak)	192A
Accuracy (r.m.s.)	0.4%+0.3%F.S.
Accuracy (peak)	0.4%+0.6%F.S.
Resolution	0.01 A
<b>Power</b>	
Accuracy	0.4%+0.4% F.S.
Resolution	0.1 W

<b>Others</b>	
Efficiency	82 %
Size (W×H×D)	483 mm × 799 mm × 630 mm
Weight	170 Kg
Protection	UVP, OCP, OPP, OTP, FAN
<b>Temperature range</b>	
Operation	0 °C to 40 °C
Storage	-40 °C to 85 °C
Humidity	30 % to 90 %
Safety & EMC	CE

**Remarks**

- \*1: Maximum distortion is tested under output 125VAC (150V RANGE) and 250VAC (300V RANGE) with maximum current to linear load.
- \*2: Load regulation is tested with sinewave and remote sense.
- \*3: Efficiency is tested on input voltage: 220V.

## 1.4 Names of Parts

### 1.4.1 The Front Panel

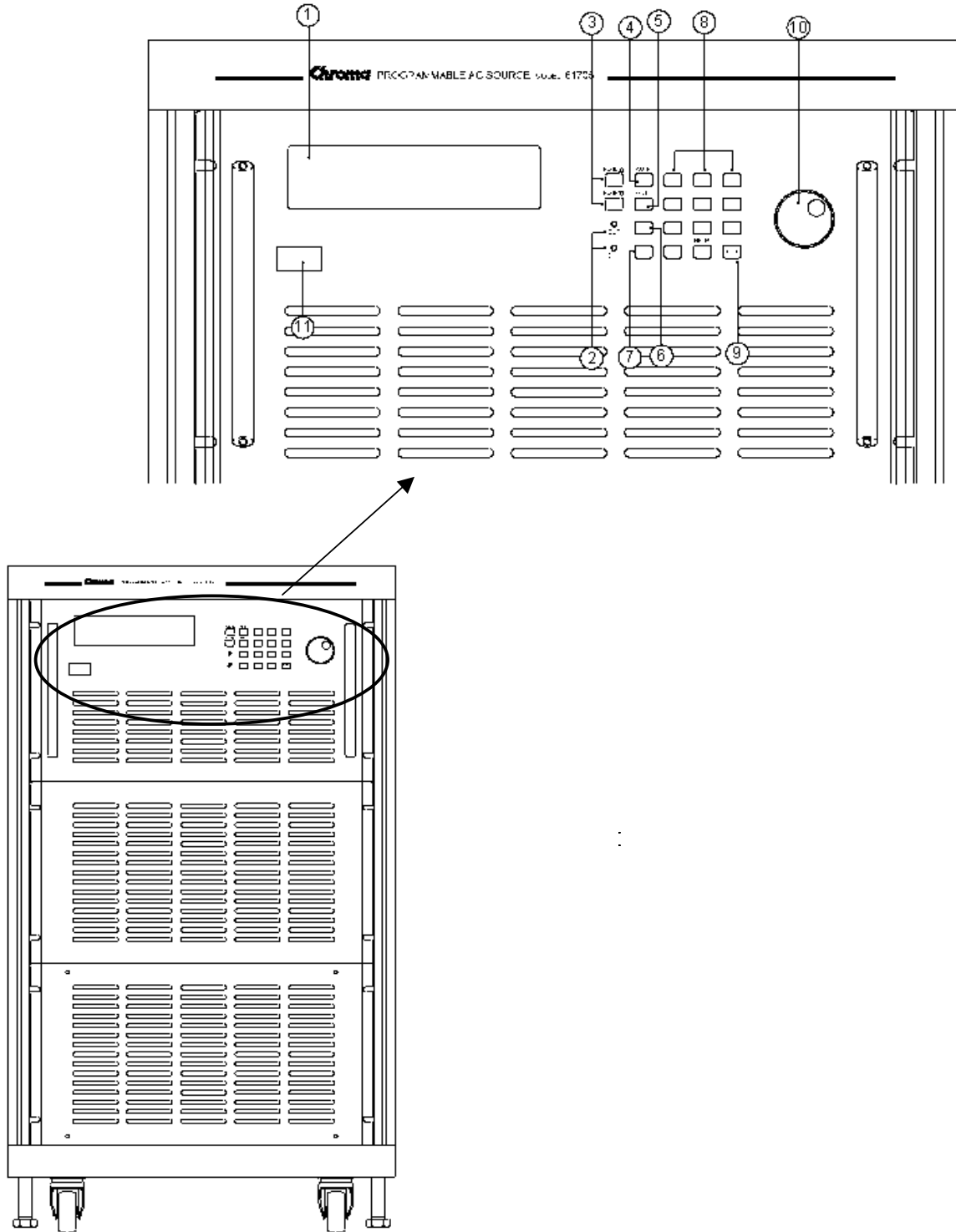

Figure 1-1 The Front Panel









Item	Symbol	Description
1		<b>Display:</b> The LCD displays the configuration, output setup, and measurement results.
2		<b>Indicator LED:</b> “OUT” and “SHIFT”, for showing activation of output and shift mode, are available and located on the keypad area next to the corresponding keys.
3	  -----or----- PAGE ▲ PAGE ▼	<b>Cursor moving keys:</b> These two keys move the cursor to different directions respectively. In normal mode, pressing any of these two keys will change the place of the cursor. Under shift mode, these keys enable the LCD display to change to the last page or next page if ▲ or ▼ patterns appear in the lower right of display.
4	 -----or----- SAVE	<b>PAGE or EXIT command key:</b> Pressing this key will switch the LCD display between MAIN PAGE and CHOICE PAGE, or change to CHOICE PAGE in each functional list. Under shift mode, pressing this key in CHOICE PAGE, it can save the system data (see 3.8).
5	 -----or----- RECALL	<b>Backspace and Minus command key:</b> Pressing this key will erase the keyin number. It may show “-“ if there is no number. Under shift mode, pressing the key in CHOICE PAGE, it can recall system data (see 3.8).
6		<b>OUT/QUIT command key:</b> Pressing this key may enable the AC Source output voltage or quit the output voltage.
7		<b>Shift mode selection key:</b> Pressing this key will switch the AC Source from normal operational mode to shift mode.
8	 -----or----- HELP	<b>Numeric and decimal keys:</b> The digital and decimal keys can program the numeric data.
9		<b>ENTER key:</b> It is to confirm the setting of parameters.
10		<b>RPG:</b> The programming data and options can be inputted by turning the RPG to the desired ones.
11		<b>Main power switch:</b> It powers on or off the AC Source.

Table 1-1 The Description of the Front Panel

## 1.4.2 The Rear Panel



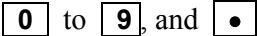

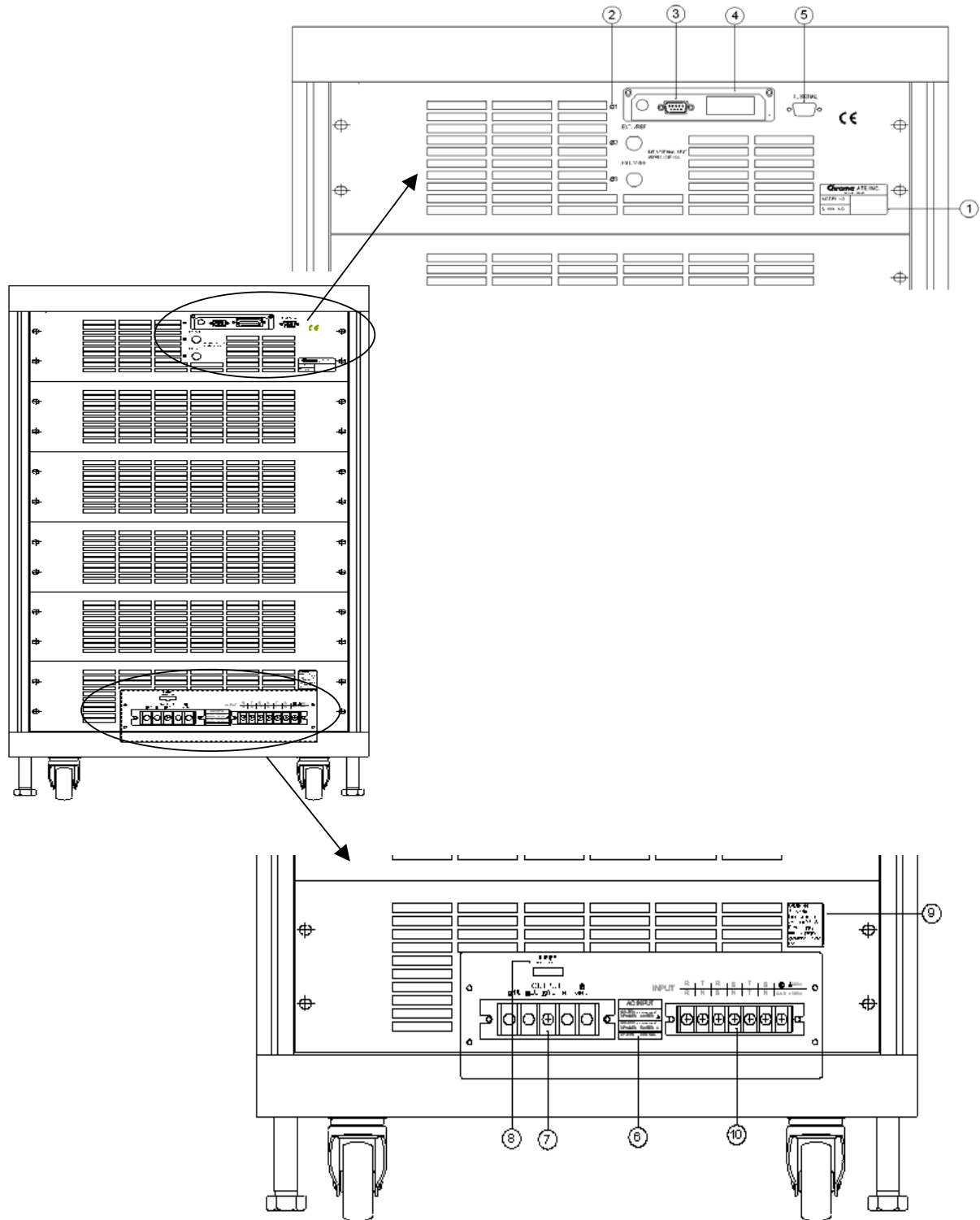
<b>Item</b>	<b>Name</b>	<b>Description</b>
1	Label	The label includes model number, serial number of the AC Source.
2	Ext. Ref.	The BNC connector inputs control waveform amplitude from external analog signal. (This function is reserved now.)
3	RS-232C	The 9-pin, D-type female connector transfers control commands to and from the remote PC for remote operation.
4	GPIB Connector	A remote controller using GPIB bus is connected to the AC Source through this connector for remote operation.
5	TTL SIGNAL	The 9-pin, female connector transmits the control signals (fault_out, remote inhibit, and AC_ON). (See <i>Appendix A</i> )
6	Warning Label	A warning for the leakage current.
7	Output Connector	This connector outputs power to the loading device.
8	Remote Sense Connector	It senses directly at the terminals of the load to eliminate any voltage drop on the connecting cable. Reverse polarity is not allowed.
9	Power Line in Connector	Power line input is connected to the AC Source through this connector.



## 2. Installation

### 2.1 Inspection

After unpacking the instrument, please inspect any damage that may have occurred during the shipment. Keep all of the packing materials in case the device has to be returned for repair.

If any damage is found, please file a claim with the carrier immediately. Do not return the instrument to the factory without obtaining prior RMA acceptance from Chroma.

### 2.2 Preparation for Use

In the beginning, the instrument must be connected with an appropriate AC line input. Then, since fans intelligently cool it, it must be installed in sufficient space for circulation of air. It should be used in an area where the ambient temperature does not exceed 40°C.

### 2.3 Requirements of Input Power

#### 2.3.1 Ratings

Input Voltage Range	: 190 ~ 250 V <sub>LL</sub> , 3phase, 4wires $\Delta$ or 329 ~ 433 V <sub>LL</sub> , 3phase, 5wires Y
Input Frequency	: 47-63 Hz
Input Max. Current	: 28 A (per phase)

---

#### **⚡ CAUTION**

The AC Source may be damaged if it is operated at an input voltage outside the configured input range.

---

#### 2.3.2 Input Connection

The input terminal block is located on the device rear panel. A power cord with four or five conductors rated at least for 85°C is required. The power line input must have a current rating that is greater than or equal to the maximum current rating of the AC Source. Do not use three separate wires to connect power to the AC Source input.

---

#### **⚡ CAUTION**

There are two different input voltage rating models. One is 380 V<sub>LL</sub> 3 phases with 5 wires (Y), and the other is 220 V<sub>LL</sub> 3 phases with 4 wires ( $\Delta$ ). Be sure to verify the main voltage before use.

---

Do the following things one by one as Figure 2-1 and 2-2 shows:

1. Remove the safety cover from the back of the AC Source.
2. Select the proper iron and screw the power cord to the input terminal blocks of the AC Source. (See Figure 2-1 and 2-2)
3. Slip the safety cover over the ac input terminal strip, and secure the cover with four screws.

**⚠ WARNING**

To protect the operators, the wire connected to the GND terminal must be connected to the earth. Under no circumstances shall this AC Source be operated without an adequate ground connection.

Installation of the power cord must be done by a professional and compliant with local electrical codes.

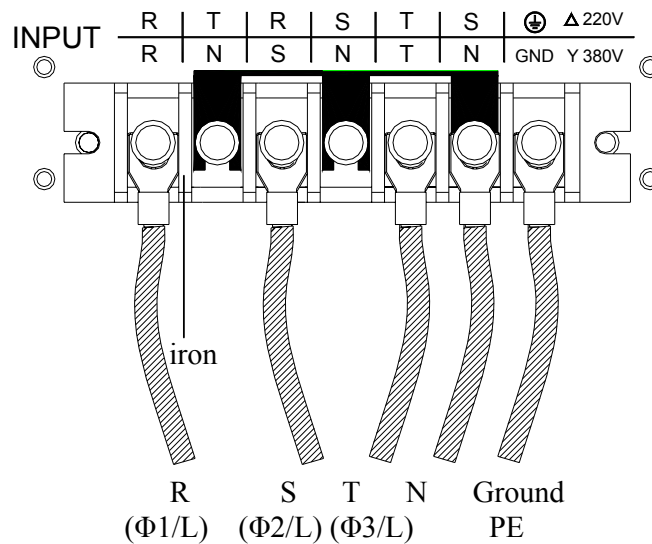

Figure 2-1 380 3~Y Input Connection

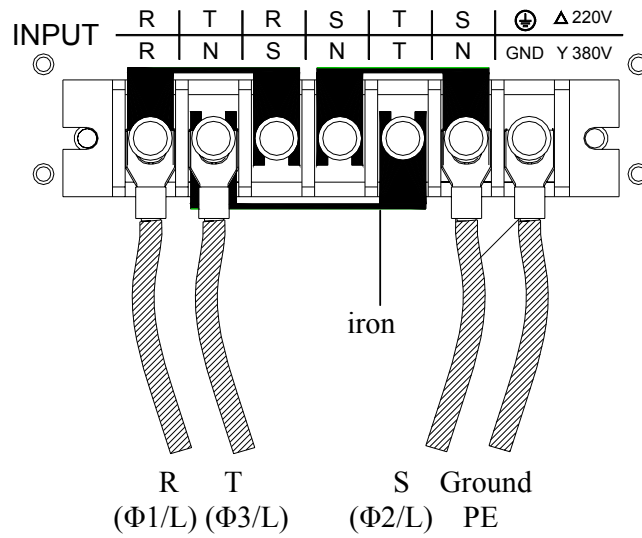

Figure 2-2 220 3~Δ Input Connection

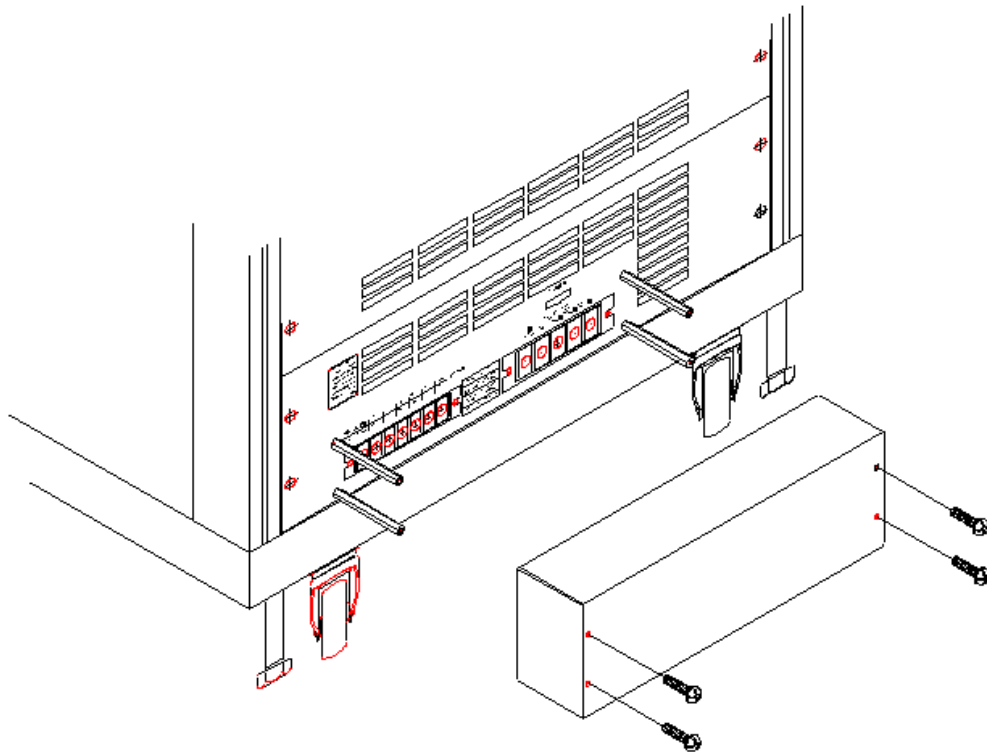

Figure 2-3 Terminal Safety Cover

## 2.4 Output Connection

The output terminal block is located in the rear of the AC Source. Load connecting to the “ $\Phi 1/L$ ”, “ $\Phi 2/L$ ”, “ $\Phi 3/L$ ”, “N” and “G” are done at the output terminals. To meet the safety requirements, the safety cover must be fastened. The wires to the load must be sufficiently large gauges, so they will not overheat while carrying the output current, see Figure 2-4.

---

### ⓘ NOTICE

The output terminal labeled “L” is the “+” terminal, and the terminal labeled “N” is the “-” terminal when output voltage contains DC composition.

---

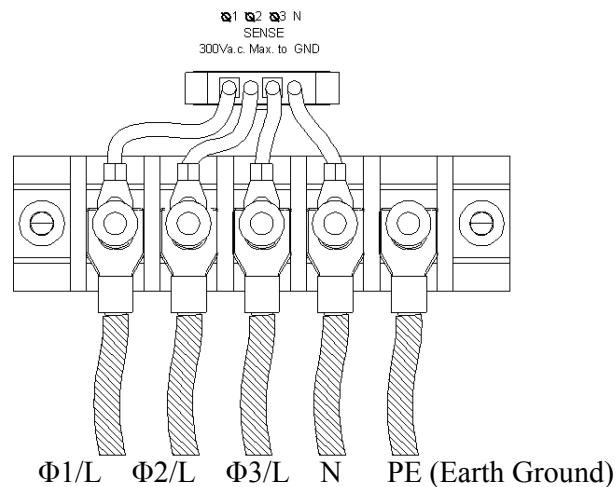

Figure 2-4 Output Terminal Connection

## 2.5 Remote Sense Connection

The remote sense function of the AC Source monitors the voltage at the load instead at the output terminal of the AC Source. It ensures the delivery of accurate voltage as programmed at the load by automatically compensating the output voltage drop over the connecting cable.

Connect the sensing leads as shown in Figure 2-5. Because the sensing leads carry only a few milliamperes, the wires for sensing are much lighter than the load leads. The sensing leads are part of the feedback path of the AC Source, so they must be kept at a low resistance in order to maintain the best performance. Connect the sensing leads carefully so that they will not be open-circuited. If the sensing leads are left unconnected or become open-circuited during operation, the AC Source will disable the output. The sensing leads must be a twisted pair to minimize the pickup of external noise. The sensing leads need to be connected to the load as close as possible.

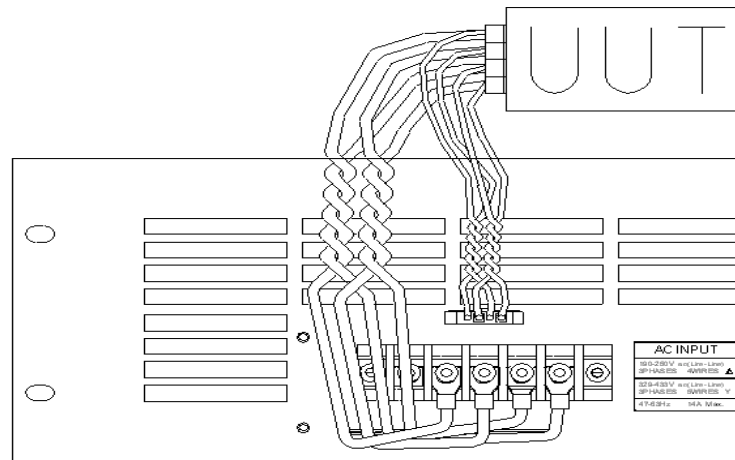

Figure 2-5 Output &amp; Remote Sense Connection

## 2.6 Power-On Procedures

### **WARNING**

Before turning on the instrument, all protective earth terminals, extension cords, and devices connected to the instrument must be connected to a protective earth ground. Any interruption of the protective earth grounding will cause a potential shock hazard that could result in personal injury.

Apply the line power and turn on the power switch on the front panel. The AC Source will do a series of self-tests. The LCD on the front panel will light up and display as below.

Meanwhile, the AC Source will do the memory, data and communication self-test. After the routines of self-tests are done, the display shows the MODEL number, and the serial number of the AC Source, and it shows an “OK” at the right side of each test item indicating that the item is no problem. It takes about six seconds to complete the routines of the self-test. Then the display shows the versions of software as below.

**Chroma Programmable AC Source**

**1. SELF TEST**

<b>WAVEFORM1</b>	<b>OK</b>	<b>PANEL</b>	<b>OK</b>
<b>WAVEFORM2</b>	<b>OK</b>	<b>REMOTE</b>	<b>OK</b>
<b>WAVEFORM3</b>	<b>OK</b>		

**2. VERSION QUERY**

<b>WAVEFORM1</b>	<b>1.02</b>	<b>PANEL</b>	<b>1.02</b>
<b>WAVEFORM2</b>	<b>1.02</b>	<b>REMOTE</b>	<b>1.05</b>
<b>WAVEFORM3</b>	<b>1.02</b>		

If any failure is detected on a certain item, an "ERROR CODE" will be shown at the right side of that item. The error messages and trouble-shooting are shown on section 6.2 in this manual. The test item " REMOTE " shows < EMPTY>, if the option board (with GPIB and RS-232) is not connected.

After finishing memory, data and communication self-test, the AC Source do the power output self-test. In this procedure, the output relays are in OFF status to sure not harming the load connecting on output terminal. The AC Source will program 300Vac to each phase and measure the voltage. If the measured voltage is over 300V±5V, the power self-test is failed, and the display will show "NG". If it's ok, the display is shown as below. Then, it changes to MAIN PAGE automatically.

**3. OUTPUT TEST**

<b>WAVEFORM1</b>	<b>OK</b>	<b>MODEL: 61705</b>
<b>WAVEFORM2</b>	<b>OK</b>	<b>SERIAL NO.: 123456</b>
<b>WAVEFORM3</b>	<b>OK</b>	

---

**ⓘ NOTICE**

1. Users can do diagnosis if error or NG happens in power-on self-test procedure. Please see section 7.2 in this manual.
  2. The inner digital circuit of AC Source may not be reset if turning off and on immediately. Waiting more than 3 seconds is suggested to turn on power after turning off.
-



## 2.7 I/O Connectors (Option)

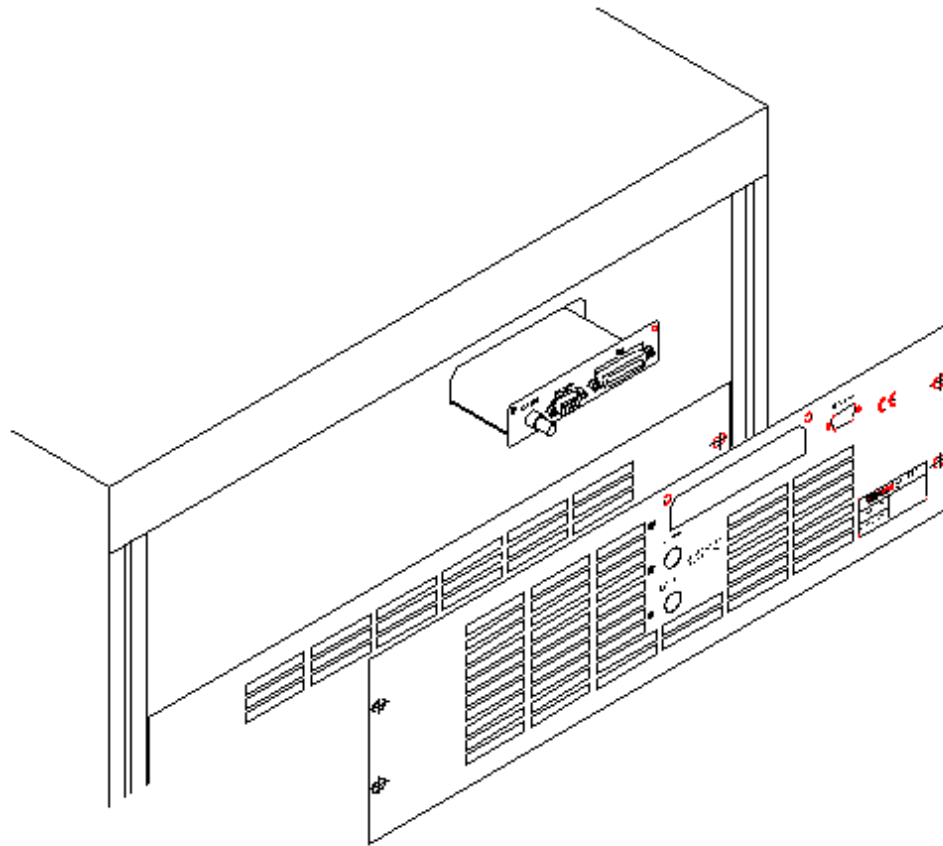

Figure 2-6 Option Board

This option board is for remote control interface: GPIB and RS-232.



## 3. Local Operation

### 3.1 Introduction

The AC Source can be configured to operate in local or remote mode. The operation in remote mode through a remote GPIB controller or RS-232C is described in Chapter 8. In this section the operation in local mode via keypad on the front panel for data entry and test is described. The AC Source is configured for local operation when it is turned on.

### 3.2 Operation through Keypad and RPG

The AC Source provides users a friendly programming interface using the keypad and RPG (Rotary Pulse Generator) on the front panel. Each display of the LCD on the AC Source represents an operational menu.

The command tree is shown in Figure 3-1. Before explaining each menu, the following shows how to use keypad and RPG to set commands. When the power-on procedure is finished (see 2.6), the display will show MAIN PAGE as below.

<b>Vac = 0.0_</b>				<b>H</b>
<b>Freq = 60.00</b>			<b>Pt = 0.0</b>	
<b>Vrms</b>	<b>Φ1 = 0.00</b>	<b>Φ2 = 0.00</b>	<b>Φ3 = 0.00</b>	<b>▲</b>
<b>I rms</b>	<b>Φ1 = 0.00</b>	<b>Φ2 = 0.00</b>	<b>Φ3 = 0.00</b>	<b>▼</b>

If the parameter of V\_SET of OUTPUT Functional list is INDIVIDUAL (see 3.7.1), the display will show MAIN PAGE as below.

<b>Vac1 = 0.0_</b>	<b>Vac2 = 0.0</b>	<b>Vac3 = 0.0</b>	<b>H</b>	
<b>Freq = 60.00</b>		<b>Pt = 0.0</b>		
<b>Vrms</b>	<b>Φ1 = 0.00</b>	<b>Φ2 = 0.00</b>	<b>Φ3 = 0.00</b>	<b>▲</b>
<b>I rms</b>	<b>Φ1 = 0.00</b>	<b>Φ2 = 0.00</b>	<b>Φ3 = 0.00</b>	<b>▼</b>

Press **▲**, **▼** to move the cursor to choose an item. Use numeric and decimal keys or RPG to set the value, and then press **ENTER** to confirm. Users can press **PAGE/EXIT** to change to CHOICE PAGE as below. Or press **PAGE/EXIT** again to return to MAIN PAGE.

**PAGE CHOICE = 1\_**

**1. SETUP   2.CONF   3.OUTPUT   4. MANUAL CALI  
5. LIST   6. PULSE   7. STEP   8. INTERHAR**

In CHOICE PAGE, users can press numeric key then **ENTER** to choose the functional lists. After entering each functional list, press **▲**, **▼** to move the cursor to destination. If number expresses the settings, users can use numeric and decimal keys or RPG to set the value, then press **ENTER** to confirm. If words express the settings, users can turn RPG to choose, then press **ENTER** to confirm.

If there are **▲** or **▼** patterns at the lower right of display, it means there are functional lists on previous page or next page. Users can press **SHIFT** then **▲** or **▼** to change page. When finished the setting, press **PAGE/EXIT** to return to CHOICE PAGE.

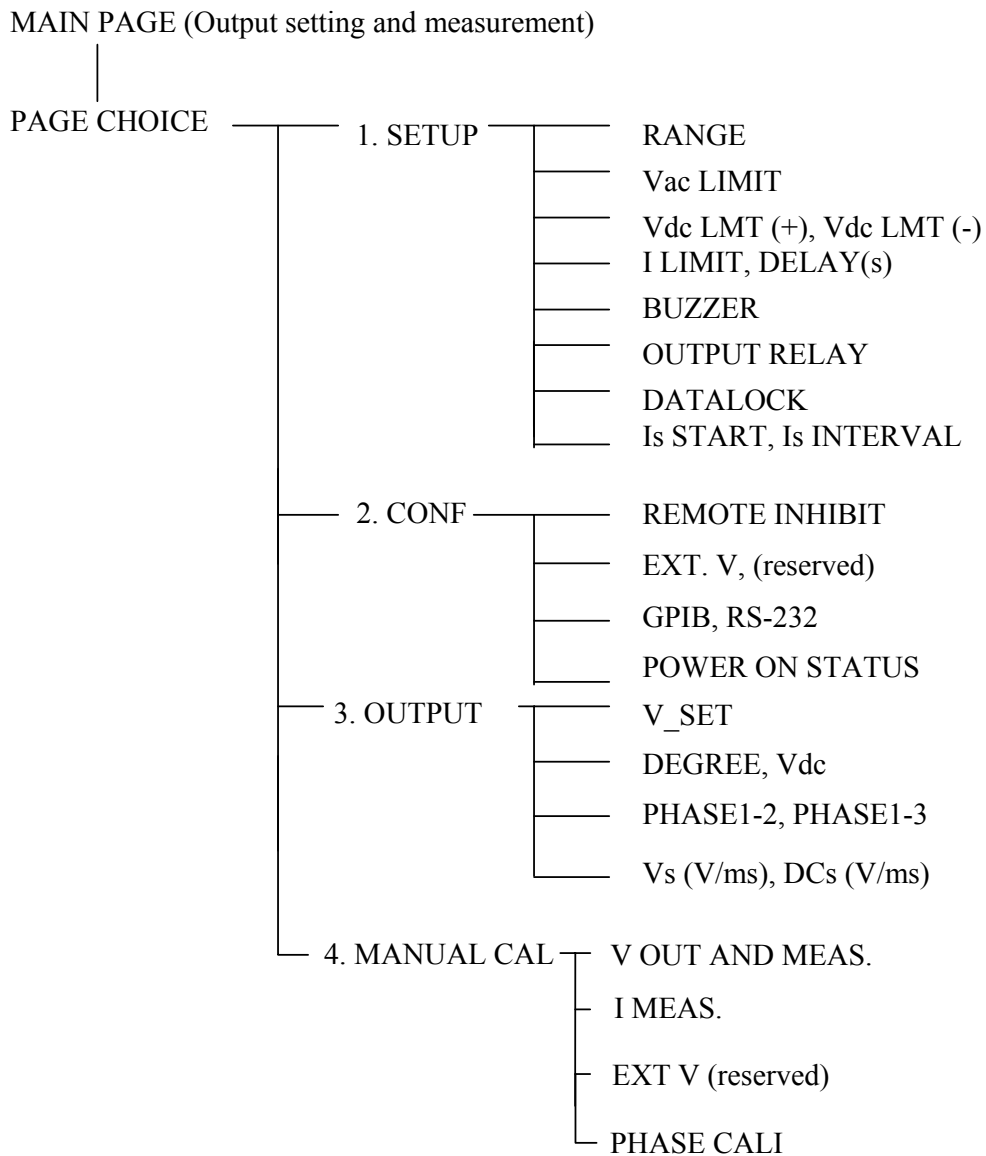

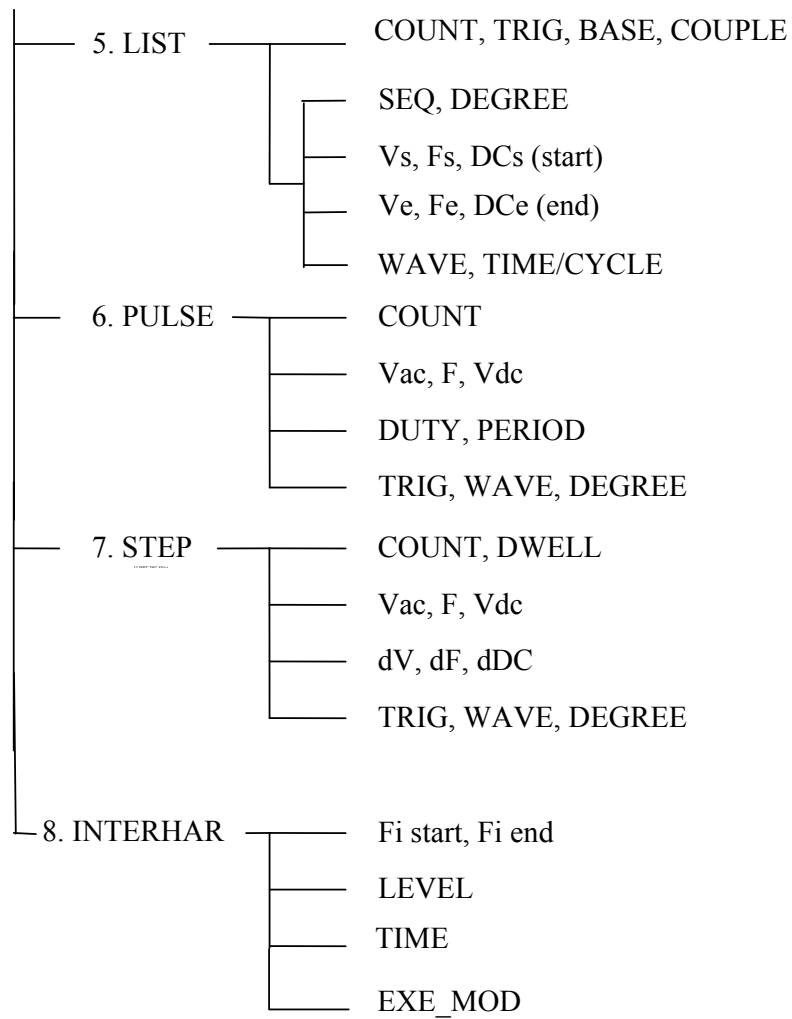

Figure 3-1

### 3.3 MAIN PAGE (Output Setting and Measurement)

When users turn on the AC Source, the display shows the MAIN PAGE after self-tests. The upper line of display shows the output settings. The state of default output settings can be set on POWER ON STATUS in CONF functional list (see 3.6.5). The lower lines show the measurements of AC Source output, see the following.

<b>Vac</b>	<b>= 0.0_</b>				<b>H</b>
<b>Freq</b>	<b>= 50.00</b>		<b>Pt = 0.0</b>		
<b>Vrms</b>	<b>Φ1 = 0.00</b>	<b>Φ2 = 0.00</b>	<b>Φ3 = 0.00</b>		<b>▲</b>
<b>I rms</b>	<b>Φ1 = 0.00</b>	<b>Φ2 = 0.00</b>	<b>Φ3 = 0.00</b>		<b>▼</b>

Press **SHIFT**, then **▲** or **▼** to change to next page as shown below.

<b>Vac</b>	<b>= 0.0_</b>				<b>H</b>
<b>Freq</b>	<b>= 50.00</b>		<b>Pt = 0.0</b>		
<b>P</b>	<b>Φ1 = 0.00</b>	<b>Φ2 = 0.00</b>	<b>Φ3 = 0.00</b>		<b>▲</b>
<b>PF</b>	<b>Φ1 = 0.000</b>	<b>Φ2 = 0.000</b>	<b>Φ3 = 0.000</b>		<b>▼</b>

If the parameter of V\_SET of OUTPUT Functional list is INDIVIDUAL (see 3.7.1), the display will show MAIN PAGE as below.

<b>Vac1 = 0.0_</b>	<b>Vac2 = 0.0</b>	<b>Vac3 = 0.0</b>		<b>H</b>
<b>Freq = 50.00</b>		<b>Pt = 0.0</b>		
<b>Vrms</b>	<b>Φ1 = 0.00</b>	<b>Φ2 = 0.00</b>	<b>Φ3 = 0.00</b>	<b>▲</b>
<b>I rms</b>	<b>Φ1 = 0.00</b>	<b>Φ2 = 0.00</b>	<b>Φ3 = 0.00</b>	<b>▼</b>

On the upper right of display, the letter “L” shows the status of RANGE (see 3.5.1). Here lists the definition of letters:

L : 150V RANGE  
H : 300V RANGE

The definitions of output setting parameters are:

Vac : It is the AC composition of output voltage in Volts.  
Freq : It is the output frequency in Hertz.

**ⓘ NOTICE**

When Vdc is set (see 3.5.3), the output is the combination of Vac and Vdc. However, the combination of peak voltage cannot exceed the limit of each range (150V RANGE: 212.1V, 300V RANGE: 424.2V). If it happens, the output voltage will quit to 0V automatically, and go to the protection condition.

---

The definitions of measurement parameters are:

- Pt : It is the measurement readings of total Power in Watts.
- V : It is the measurement readings of Voltage in Volts. (True RMS measurement)
- I : It is the measurement readings of Current in Amperes. (True RMS measurement)
- Freq : It is the output frequency in Hertz.
- P : It is the true Power measurement in Watts.
- PF : It is the Power Factor, and its calculation formula = true power/ (Vrms × Irms)
- CF : It is the Crest Factor, and its calculation formula = Ipeak/Irms.
- Vdc : It is the DC composition measurement readings of Voltage in Volts.
- Idc : It is the DC composition measurement readings of Current in Amperes.
- Ip : It is the peak current measurement in Amperes.
- Is : It is the I surge, and only measured from the occurrence of output transition as defined in 3.5.8.
- VA : It is the Apparent Power in Watts, and its calculation formula = Vrms × Irms.
- VAR : It is the calculation formula =  $\sqrt{VA^2 - P^2}$

Press  or  to move the cursor to the measurement column, and then use RPG to change the measurement items as desired.

### 3.4 CHOICE PAGE (Functional List Choice)

Users can press  to change to CHOICE PAGE from MAIN PAGE or functional list pages.

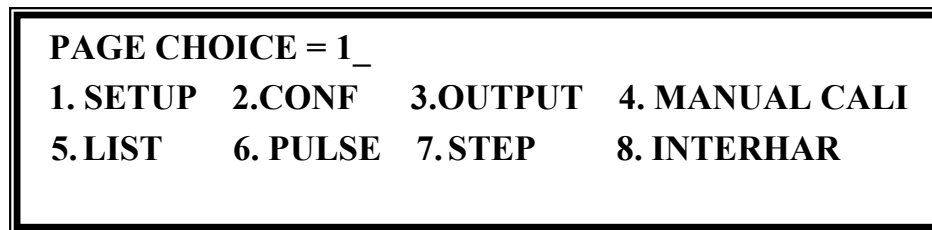

Users can press  -  to choose an operational list item, then press  to confirm it. The display will switch to MAIN PAGE by pressing  on CHOICE PAGE.



### 3.5 SETUP Functional List

On CHOICE PAGE (see 3.4), press **1** then **ENTER** to choose the SETUP functional list.

```

PAGE CHOICE = 1_
1.SETUP  2.CONF  3.OUTPUT  4. MANUAL CALI
5.LIST   6. PULSE 7.STEP   8. INTERHAR
  
```

```

RANGE = 150V_ [ SETUP ]
Vac LIMIT = 300
Vdc LMT (+) = 424.2   Vdc LMT (-) = 0.0
I LIMIT (A) = 0.0     DELAY (s) = 0.0 ▼
  
```

Press **SHIFT**, then **▼** to change to next page.

```

BUZZER = ON   OUTPUT RELAY = ON [ SETUP ]
DATA LOCK = OFF
Is START = 0.0 ms
Is INTERVAL = 50.0 ms ▲
  
```

#### 3.5.1 RANGE

The AC Source supplies full range of output voltage with options of 150 V and 300 V for each phase. Users can set RANGE on SETUP functional list (see section 3.5). This parameter controls relays to parallel (150V RANGE) or series (300V RANGE) power stages to obtain more current or higher voltage.

To set the range of output voltage as 150V as below:

1. Move the cursor to the command line of RANGE.
2. Turn the RPG to change the option from “300V” to “150V”, then press **ENTER**.

```
RANGE = 300V_
```

```
RANGE = 150V
```

**ⓘ NOTICE**

The AC Source will set output voltage to 0V first in order to eliminate voltage spike when range changes. Then, it will set output voltage to the new setting value. It may cause the UUT to shut down or be damaged if the output is active when the range changes.

---

### 3.5.2 Vac LIMIT

The setting of Vac LIMIT will restrict the value of Vac in MAIN PAGE. Users can set Vac LIMIT on SETUP functional list (see 3.5). This command is about user-programmable protection, not hardware protection.

The procedures for setting Current Vac LIMIT = 120V, are described as below:

1. Move the cursor to the command line of "Vac LIMIT =".
2. Press **1**, **2**, **0** then press **ENTER** to change the value to "120.0".

Vac LIMIT = 300.0\_

Vac LIMIT(A) = 120.0

**ⓘ NOTICE**

The setting of Vac LIMIT is not restricted by RANGE, but the Vac on MAIN PAGE is restricted by RANGE. For example, in 150V RANGE, although Vac LIMIT= 200V, the largest value of Vac setting is 150V.

---

### 3.5.3 Vdc LIMIT (+), Vdc LIMIT (-)

Vdc LIMIT (+) and Vdc LIMIT (-) limit the setting value of Vdc on MAIN PAGE. Users can set both on SETUP functional list (see 3.5). The setting value of Vdc cannot be higher than Vdc LIMIT (+) or lower than Vdc LIMIT (-). Vdc LIMIT (+) must be positive or zero, while Vdc LIMIT (-) must be negative or zero. This command is about user-programmable protection, not hardware protection.

The procedures of setting Vdc LMT (+)=200V, Vdc LMT (-)=-50V are described as below:

1. Move the cursor to the command line of "Vdc LIMIT(+)=".
2. Press **2**, **0**, **0** then press **ENTER** to change the value to "200.0".
3. The cursor moves to the command line of "Vdc LIMIT(-)= " automatically.

Vdc LMT(+) = 424.2\_ Vdc LMT(-) = 0.0

Vdc LMT(+) = 200.0 Vdc LMT(-) = 0.0\_

Vdc LMT(+) =200.0 Vdc LMT(-) = -50\_

4. Press  $\leftarrow / -$ , **5**, **0** then press **ENTER** to change the value to “-50.0”.

Vdc LMT(+) = 200.0    Vdc LMT(-) = -50.0

### **ⓘ NOTICE**

1. The setting of Vdc LIMIT is not restricted by RANGE, but the Vdc on MAIN PAGE is still restricted by RANGE. For example, in 150V RANGE, although Vdc LIMIT = 250V the largest value of Vdc setting is 212.1V.
2. When the AC Source output contains Vdc, it's better to restrict the value of Vdc. It may cause damage if output polarity is reversed, especially if the load has polar.

## 3.5.4 I LIMIT, DELAY

Limitations of output RMS current and delay time are the parameters for triggering over current protection. The user can set both on SETUP functional list (see 3.5). The discussion of limitation in this command is about user-programmable protection, not hardware protection.

The procedures of setting Current limit = 4A, Delay time = 1 sec., are described as below:

1. Move the cursor to the command line of “I LIMIT(A) = ”.

I LIMIT(A) = 0.00\_    DELAY(S) = 0.0

3. Press **4**, then press **ENTER** to change the value to “4.00”.

I LIMIT(A) = 4\_    DELAY(S) = 0.0

3. The cursor moves to the command line of “DELAY(S) = ” automatically.

I LIMIT(A) = 4.00    DELAY(S) = 0.0\_

4. Press **1**, **ENTER** to change the value to “1.0”.

I LIMIT(A) = 4.00    DELAY(S) = 1.0\_

### **ⓘ NOTICE**

1. When “I LIMIT (A) = 0” it means the limitation of output current is equal to specification.
2. DELAY time is valid for eliminating transient current spike, but not work when the output current is over specification. The time resolution is 0.5s.

### 3.5.5 OUTPUT RELAY

There are relays on the output of the AC Source for connecting the load. When the output relay is “ON”, it means it is closed in spite of the output status of the AC Source is in QUIT mode. When the output relay is “OFF”, it means it is closed only as the output status is in RUN mode. If the output status is in QUIT mode, the output relay will be opened. Users can set OUTPUT RELAY on SETUP functional list (see 3.5).

To set the output relay to ON as below:

1. Move the cursor to the command of OUTPUT RELAY.
2. Turn the RPG to set it to ON, then press **ENTER**.  
A click will sound from the AC Source when the output relay is activated.

OUTPUT RELAY=OFF\_

OUTPUT RELAY= ON

### 3.5.6 BUZZER

The buzzer of the AC Source beeps when users press the keypad on the front panel or turn the RPG knob. It can be turned off if it does not need. Users can set BUZZER on SETUP functional list (see 3.5).

To turn off the buzzer as follows:

1. Move the cursor to the command line of “Buzzer=”.
2. Turn the RPG to change the option from ON to OFF, then press **ENTER**.

Buzzer = ON\_

Buzzer = OFF

### 3.5.7 DATALOCK

The AC Source allows users to lock data entries, so the pre-defined parameters can be protected from being modified by unauthorized personnel. Users can set DATALOCK on SETUP functional list (see 3.5).

The procedures of the setting data lock are shown as below:

1. Move the cursor to the command line of “DATALOCK=”.

DATALOCK = OFF\_

2. Turn the RPG to change the option from OFF to ON, then press **ENTER**.

DATALOCK = ON

### **ⓘ NOTICE**

Users must select OFF to unlock.

## 3.5.8 Is START, Is INTERVAL

Is is the surge peak current of AC Source output shown in MAIN PAGE. The AC Source will wait Is START time then start to measure Is before the output voltage transition. The length of measurement time is Is INTERVAL. Users can set both on SETUP functional list (see 3.5).

The procedures of setting Is START=10ms, Is INTERVAL = 200 ms, are described as below:

1. Move the cursor to the command line of "Is START =".
2. Press **1**, **0** then press **ENTER** to change the value to "10.0".
3. The cursor moves to the command line of "Is INTERVAL =" automatically.
4. Press **2**, **0**, **0** then press **ENTER** to change the value to "200.0".

Is START= 0.0\_ ms

Is START = 10.0 ms

Is INTERVAL = 50.0\_ ms

Is INTERVAL = 200.0\_ ms

## 3.6 CONF Functional List

On CHOICE PAGE (see 3.4), press **2** then **ENTER** to choose the CONF functional list.

**PAGE CHOICE = 2\_**

**1.SETUP 2.CONF 3.OUTPUT 4.MANUAL CALI  
5.LIST 6.PULSE 7.STEP 8.INTERHAR**

REMOTE INHIBIT = OFF [ CONF ] GPIB ADD = 30                      BAUD = 19200 WAVEA[Φ1] = SINE WAVEB[Φ1] = SINE	▼
--	---

REMOTE INHIBIT = OFF [ CONF ] GPIB ADD = 30                      BAUD = 19200 WAVEA[Φ1] = CSIN    MODE = THD PER = 0.0 % WAVEB[Φ1] = CSIN    MODE = THD PER = 0.0 %	▼
--	---

WAVEA[Φ2] = SINE WAVEB[Φ2] = SINE WAVEA[Φ3] = SINE WAVEB[Φ3] = SINE	▲ ▼
--	--------

WAVEA[Φ2] = CSIN    MODE = THD PER = 0.0 % WAVEB[Φ2] = CSIN    MODE = THD PER = 0.0 % WAVEA[Φ3] = CSIN    MODE = THD PER = 0.0 % WAVEB[Φ3] = CSIN    MODE = THD PER = 0.0 %	▲ ▼
--	--------

Press **SHIFT**, then ▼ to change to next page.

POWER ON STATUS : [ CONF ] Output = OFF              Freq = 60.00 Vac = 0.0 Vdc = 0.0	▲
--	---

### 3.6.1 REMOTE INHIBIT

The output of the AC Source can be inhibited by the external control or by manual trigger. The remote inhibit signal is received from 9-pin female connector on the rear panel (see *Appendix A*). Users can set REMOTE INHIBIT on CONF functional list (see 3.6). There are three states for remote inhibit: OFF, LIVE, and TRIG.

- OFF: It disables the feature of remote inhibit.
- LIVE: The output of the AC Source will be disabled if TTL signal is LOW, but will be recovered automatically if TTL signal is HIGH.
- TRIG: The output of the AC Source will be disabled if TTL signal is LOW, and will remain in quit state even TTL signal becomes HIGH.

The procedures of setting from OFF to LIVE are shown as below:

1. Move the cursor to the command of "REMOTE INHIBIT" to set inhibition by the TTL signal from the external control.

REMOTE INHIBIT =OFF\_

2. Turn the RPG to change the option from OFF to LIVE, then press **ENTER**.

REMOTE INHIBIT =LIVE

---

### **ⓘ NOTICE**

The remote inhibit is a TTL signal transferred via the special I/O connector. For details please refer to the pin assignment in *Appendix A*.

---

## **3.6.2 EXT. V, COUPLE (Reserved)**

The AC Source allows users to make use of the controlled analog signal from external devices for setting its output. The three BNC connectors of the EXT Vref on the rear panel lets users apply signal to the AC Source for setting the 3-phase output voltage. Users can set EXT. V and COUPLE on CONF functional list (see section 3.6). There are two coupling modes to present the AC Source output from external V reference: AC\_AMPLIFIER and DC\_LEVEL\_CTL.

AC\_AMPLIFIER: The output voltage ( $V_{out}$ ) is the synthesis of voltage programming on MAIN PAGE and the amplification of external V reference with voltage range from -10V to 10V. When  $V_{ac}=0$  and  $V_{dc}=0$  on MAIN PAGE,  $V_{out}$  can be calculated using the following formula:

$$V_{out} (dc) = V_{ref} (dc) / 10 V_{dc} \times 424.2 V_{dc} \quad (300V \text{ RANGE})$$

$$V_{out} (dc) = V_{ref} (dc) / 10 V_{dc} \times 212.1 V_{dc} \quad (150V \text{ RANGE})$$

or

$$V_{out} (ac) = V_{ref} (ac) / 7.072 V_{ac} \times 300 V_{ac} \quad (300V \text{ RANGE})$$

$$V_{out} (ac) = V_{ref} (ac) / 7.072 V_{ac} \times 150 V_{ac} \quad (150V \text{ RANGE})$$

Example (1): set  $V_{out}$  to 100Vdc:

1. Select RANGE = 300V in SETUP functional list, apply external  $V = 2.357V_{dc}$ , the  $V_{out} = 100V_{dc}$ .
2. Select RANGE = 150V in SETUP functional list, apply external  $V = 4.715V_{dc}$ , the  $V_{out} = 100V_{dc}$ .

Example (2): set Vout to 100Vac:

1. Select RANGE = 300V in SETUP functional list, apply external V= 2.357Vac, the Vout = 100Vac.
2. Select RANGE = 150V in SETUP functional list, apply external V= 4.715Vac, the Vout = 100Vac.

DC\_LEVEL\_CTL : The output voltage (Vout (ac)) responses linearly proportional to the controlled DC level with voltage range from -10V to 10V. Vout can be calculated using the following formula:

$$V_{out} (ac) = | V_{ref} (dc) | / 10 V_{dc} \times 300V_{ac} (300V \text{ RANGE})$$

$$V_{out} (ac) = | V_{ref} (dc) | / 10 V_{dc} \times 150V_{ac} (150V \text{ RANGE})$$

Example (1): set Vout to 100Vac:

1. Select RANGE = 300V in SETUP functional list, apply external V= 3.333Vdc (or -3.333Vdc), the Vout = 100Vac.
2. Select RANGE = 150V in SETUP functional list, apply external V=6.667Vdc (or -6.667Vdc), the Vout = 100Vac.

The procedures of setting EXT. V = ON, COUPLE = DC\_LEVEL\_CTL, are described as below:

- |  |                                  |
|--|----------------------------------|
| 1. Move the cursor to the command of "EXT. V =".                               | EXT.V = OFF_ COUPLE=AC_AMPLIFIER |
| 2. Turn the RPG to change the option from OFF to ON, then press <b>ENTER</b> . | EXT.V = ON COUPLE=AC_AMPLIFIER_  |
| 3. The cursor moves to the command line of "COUPLE =" automatically.           | EXT.V = ON COUPLE=DC_LEVEL_CTL   |
| 4. Turn the RPG to select DC_LEVEL_CTL, then press <b>ENTER</b> .              | EXT.V = ON COUPLE=DC_LEVEL_CTL_  |

---

**ⓘ NOTICE**

When EXT. V=ON, COUPLE=DC\_LEVEL\_CTL, the output voltage (Vout) will respond to the external control DC voltage level only. Users cannot control Vout amplitude through the keypad on the front panel, until EXT.V=OFF again.

---

**⚠ WARNING**

1. When COUPLE = AC\_AMPLIFIER and the frequency of Vref is over 1200Hz, it might cause the AC Source be damaged. The formula should be followed the if F>1200Hz:  
 $V_{ref} (pk-pk, V) \times F (V_{ref}, Hz) < 10000 VHz$
  2. Because of the bandwidth limitation of AC Source, the output may be distorted. Especially when external V reference consists of high frequency composition.
-



### 3.6.3 WAVEFORM GENERATOR

The AC Source provides users with two independent sets of waveforms, A and B in each phase. Both of the waveforms contain sinusoidal, square, clipped sinusoidal, 30 sets of built-in waveforms, and 6 sets of user-defined waveforms.

To set  $\Phi 1$  waveform A as square wave:

1. Move the cursor to the command of WAVEA[ $\Phi 1$ ].
2. Turn the RPG to change the option to “SQR”, then press **ENTER**.

WAVEA[ $\Phi 1$ ]=SINE\_

WAVEA[ $\Phi 1$ ]=SQR\_

To set  $\Phi 1$  waveform B as clipped Sin wave, THD: 10 %

1. Move the cursor to command of WAVE B, choose “CSIN”.
2. Then, LCD display shows the MODE and PERCENT.
3. Turn the RPG to change the option to “THD”, press **ENTER**.
4. Press **1**, **0** then press **ENTER** to set THD to 10%.

WAVEB[ $\Phi 1$ ]=CSIN\_

MODE = AMP\_ PER = 0.0 %

MODE = THD PER = 0.0\_ %

MODE = THD PER = 10.0 %

#### **NOTICE**

1. The clipped sine is programmed by “AMPLitude” or “Total Harmonic Distortion”. Programming ranges from 0 to 100% for amplitude (100%: no clipped sine), and from 0 to 43% for THD (0%: no distortion).
2. User-defined waveform is defined on a remote PC and downloaded from it.
3. For detailed of factory DST waveform refer to *Appendix B*.

#### **WARNING**

1. When using user-defined waveform, if the waveform frequency is over 1000Hz, it might cause the AC Source be damaged.
2. Because of the bandwidth limitation of AC Source, the output may be distorted. Especially when external V reference consists of high frequency composition.

### 3.6.4 GPIB Address, RS-232C

The AC Source offers the mode of remote operation too. Users can set them on CONF functional list (see 3.6). For details please refer to Chapter 8. Prior to remote operation users have to set the GPIB address 10 as below:

1. Move the cursor to the command line of GPIB address.
2. Press **1**, **0**, **ENTER** to set address 10.

ADDR = 30\_

ADDR = 10

---

**ⓘ NOTICE**

Address ranges from 1 to 30.

---

The AC Source offers another remote operation through the RS-232C bus. Communication protocol is set as follows:

To set parity=ODD, baud rate=19200.

1. Move the cursor to the command line of PARITY.
2. Turn the RPG to select ODD, then press **ENTER**.
3. The cursor moves automatically to the position of "BAUD". Turn the RPG to select "19200", then press **ENTER**.

PARITY= NONE\_ BAUD=9600

PARITY=ODD BAUD=9600\_

PARITY=ODD BAUD=19200

---

**ⓘ NOTICE**

The options of baud rate are 9600/19200. The options of parity are EVEN/ODD/NONE.

---

### 3.6.5 POWER ON STATUS

The AC Source allows users to set the output state when the power is switched on. Users can set POWER ON STATUS on CONF functional list (see 3.6). After setting, users should save them before powering off (see 3.8.2). Users also can pre-set voltage of each phase individually if V\_SET = INDIVIDUAL (see 3.7.1).

To set the output to ON, 230 Vac, 50Hz and 0Vdc when power-on.

1. Move the cursor to the line of "POWER ON STATUS : Output =".

POWER ON STATUS: Output = OFF\_

2. Turn the RPG to set output ON, then press **ENTER**.

POWER ON STATUS: Output = ON

3. Press **2**, **3**, **0**, **ENTER** to set Vac=230.

Vac = 230.0 Freq=60.0\_ Vdc = 10.0

4. Press **5**, **0**, then press **ENTER** to set Freq=50.

Vac = 230.0 Freq=50.0 Vdc = 10.0

5. Press **0**, then press **ENTER** to set Vdc = 0.

Vac = 230.0 Freq=50.0 Vdc = 0.0

### 3.7 OUTPUT Functional List

On CHOICE PAGE (see 3.4), press **3** and **ENTER** to choose the OUTPUT functional list.

**PAGE CHOICE = 3\_**

**1. SETUP 2.CONF 3.OUTPUT 4. MANUAL CALI**  
**5. LIST 6. PULSE 7. STEP 8. INTERHAR**

**V\_SET= ALL [ OUTP ]**  
**DEG ON= 0.0 DEG OFF= IMMED**  
**Vdc= 0.0**  
**W\_F= A ▼**

**V\_SET= INDIVIDUAL [ OUTP ]**  
**DEG ON= 0.0 DEG OFF= IMMED**  
**Vdc1= 0.0 Vdc2= 0.0 Vdc3= 0.0**  
**W\_FΦ1=A W\_FΦ2=A W\_FΦ3=A ▼**

Press **SHIFT**, then **▼** to change to next page.

**[OUTP]**  
**Phase 1-2 = 120.0 Phase 1-3 = 240.0**  
**Vs (V/ms) = 0.000 DCs (V/ms) = 0.000**  
**▲**

### 3.7.1 V\_SET

There are two AC Source output setting modes: ALL and INDIVIDUAL. Users can set V\_SET on OUTPUT functional list (see 3.7) to fit the application. Then, the MAIN PAGE will change corresponding to the mode.

If V\_SET = ALL, the voltage settings of 3-phase output are all the same. The MAIN PAGE is as below.

<b>Vac</b> = 0.0_				<b>H</b>
<b>Freq</b> = 50.00			<b>Pt</b> = 0.0	
<b>P</b>	<b>Φ1</b> = 0.0	<b>Φ2</b> = 0.0	<b>Φ3</b> = 0.0	<b>▲</b>
<b>PF</b>	<b>Φ1</b> = 0.00	<b>Φ2</b> = 0.00	<b>Φ3</b> = 0.00	<b>▼</b>

If V\_SET = INDIVIDUAL, the voltage settings of 3-phase output can be set individually. The MAIN PAGE is as below.

<b>Vac1</b> = 0.0_	<b>Vac2</b> = 0.0	<b>Vac3</b> = 0.0	<b>H</b>	
<b>Freq</b> = 50.00		<b>Pt</b> = 0.0		
<b>Vrms</b>	<b>Φ1</b> = 0.0	<b>Φ2</b> = 0.0	<b>Φ3</b> = 0.0	<b>▲</b>
<b>I rms</b>	<b>Φ1</b> = 0.00	<b>Φ2</b> = 0.00	<b>Φ3</b> = 0.00	<b>▼</b>

The procedures of setting from ALL to INDIVIDUAL are shown as below:

1. Move the cursor to the command of "V\_SET=".
2. Turn the RPG to change the option from ALL to INDIVIDUAL, then press **ENTER**.

COUPLE = ALL\_

COUPLE= INDIVIDUAL

### 3.7.2 Output Degree

The AC Source can control the transition angle of the waveform when it is out or quits. Users can set DEG ON and DEG OFF to achieve it in OUTPUT functional list (see 3.7.)

The procedures for setting output phase angle DEGREE ON = 90 and OFF=180 are described as below:

1. Move the cursor to the command line of "ON =".
2. Press **9**, **0**, then **ENTER** to change the value to "90.0".

DEG ON = 0.0\_ DEG OFF= IMMED

DEG ON = 90.0 DEG OFF= IMMED\_

3. The cursor moves to the command line of "OFF=" automatically.

4. Press **1**, **8**, **0**, then press **ENTER** to change the value to "180.0".

DEG ON = 90.0    DEG OFF= 180.0

### **ⓘ NOTICE**

1. The output or quit phase angle of waveform is set for Phase 1 ( $\Phi 1$ ). The other phases will follow Phase 1 to out or quit at the same time.
2. If "OFF=IMMED", the output voltage quits immediately when users press **QUIT**. But if the degree is set, the output voltage will last till the set degree. Keyin "OFF= 360" became "OFF= IMMED".

## 3.7.3 Vdc Output

The AC Source can program output voltage that contains DC component by setting Vdc on OUTPUT functional list (see 3.7). Users can also set DC component of each phase individually if V\_SET = INDIVIDUAL (see 3.7.1).

The procedures of setting Vdc = 2V are described as below:

1. Move the cursor to the command line of "Vdc =".

Vdc = 0.0\_

2. Press **2**, then press **ENTER** to change the value to "2.0".

Vdc = 2.0

### **ⓘ NOTICE**

The DC component of AC Source output is applied to do certain voltage tests. The AC Source does not have numerous output capacitors; some features like voltage ripple and load transient are not similar to DC Ssource.

## 3.7.4 Phase Angle Setting

For a 3-phase AC power system, the phase angle in between is  $120^\circ$ . The AC Source of 61700 can program the phase angle  $0\sim 360^\circ$ , not fix to  $120^\circ$  only. Users can set PHASE 1-2 and PHASE 1-3 to achieve it in OUTPUT functional list (see 3.7). The parameter of PHASE 1-2 means the phase angle between Phase 1 ( $\Phi 1/L$ ) and Phase 2 ( $\Phi 2/L$ ).

The procedures of setting a balance phase angle are described as below:

1. The cursor moves to the command line of "PHASE 1-2=".

PHASE 1-2=0.0    PHASE 1-3 =0.0

2. Press **[1]**, **[2]**, **[0]**, then press **ENTER**.

PHASE 1-2=120.0    PHASE 1-3 =0.0\_

3. The cursor moves to the command line of "PHASE 1-3=" automatically.

4. Press **[2]**, **[4]**, **[0]**, then press **ENTER**.

PHASE 1-2=120.0    PHASE 1-3 =240.0\_

---

**ⓘ NOTICE**

Users cannot connect  $\Phi 1/L$ ,  $\Phi 2/L$ ,  $\Phi 3/L$  terminals of AC Source outputs together, even the PHASE 1-2 = 0 and PHASE 1-3 = 0 are set.

---

### 3.7.5 Slew Rate of Output Transient

The AC Source can control the transition waveform of the output by setting Vs and DCs on OUTPUT functional list (see 3.7). Users can use Vs (V/ms) and DCs (V/ms) two commands to achieve the transient state of output waveform.

Vs: the slew rate of output Vac

DCs: the slew rate of output Vdc.

When users change the output setting in MAIN PAGE, the output voltage will change corresponding to the Vs, DCs commands.

The procedures of setting Vs (V/ms)=0.2 and DCs (V/ms)=0.1 are described as below:

1. Move the cursor to the command line of "Vs (V/ms) = ".

Vs (V/ms) = 0.000\_

2. Press **[0]**, **[.]**, **[2]**, then press **ENTER** to change the value to "0.2".

Vs (V/ms) = 0.200

3. The cursor moves to the command line of "DCs (V/ms)=" automatically. Press **[0]**, **[.]**, **[1]**, then press **ENTER**.

DCs (V/ms) = 0.100\_

---

**ⓘ NOTICE**

1. When users set Vs (V/ms)=0, DCs (V/ms)=0, the output transient is in the fastest speed.
  2. Vs and DCs have large input range in software programming, but the output may not follow the slew rate exactly when Vs and DCs are too large.
  3. When users press **OUT** or **Quit**, the output voltage will change immediately. If users want to out or quit the output with the set slew rate, 0V must be keyin then press **ENTER**.
-

## 3.8 Save and Recall

The AC Source offers two modes for the user to save and recall output setting or system data. They are described in 3.8.1 and 3.8.2.

### 3.8.1 Save and Recall Output Setting

The AC Source offers nine channels for users to save a set of frequently used Vac, F, Vdc, and to recall them for future use.

Under the MAIN PAGE:

<b>Vac1 = 0.0_</b>	<b>Vac2 = 0.0</b>	<b>Vac3 = 0.0</b>	<b>H</b>
<b>Freq = 60.00</b>		<b>Pt = 0.0</b>	
<b>Vrms</b>	<b>Φ1 = 0.00</b>	<b>Φ2 = 0.00</b>	<b>Φ3 = 0.00</b>
<b>I rms</b>	<b>Φ1 = 0.00</b>	<b>Φ2 = 0.00</b>	<b>Φ3 = 0.00</b>
			<b>▲</b>
			<b>▼</b>

Press **SHIFT** then **PAGE/EXIT** to run the SAVE function. The display will show as below:

<b>CHOICE 1-9, PRESS &lt;ENTER&gt; TO SAVE</b>			
<b>1_</b>	<b>Vac1= 0.0</b>	<b>Vdc1= 0.0</b>	
	<b>Vac2= 0.0</b>	<b>Vdc2= 0.0</b>	
	<b>Vac3= 0.0</b>	<b>Vdc3= 0.0</b>	<b>F=60.00</b>

Users can press **1** - **9** to select a channel, then press **ENTER** to save the output setting. Press **PAGE/EXIT** to return to MAIN PAGE.

Recalling from memory channel to MAIN PAGE is shown as follows. In MAIN PAGE, press **SHIFT** then **←/-** to run the RECALL function. The display appears as below:

<b>CHOICE 1-9, PRESS &lt;ENTER&gt; TO RECALL</b>			
<b>1_</b>	<b>Vac1= 100.0</b>	<b>Vdc1= 20.0</b>	
	<b>Vac2= 100.0</b>	<b>Vdc2= 20.0</b>	
	<b>Vac3= 100.0</b>	<b>Vdc3= 20.0</b>	<b>F=60.00</b>

Users can press **1** - **9** to select a channel, then press **ENTER** to recall the output setting. Afterward the display returns to MAIN PAGE automatically.

If the recalled settings are out of RANGE or over the V LIMIT (see 3.5.2, 3.5.3), the display will show the following:

**Conflicting with RANGE or V LIMIT**  
**Press <ENTER> key to Exit**

**ⓘ NOTICE**

1. The function to save and recall output settings is for MAIN PAGE settings only. Other parameters are ignored.
2. If V\_SET=ALL (see 3.7.1), the recall settings for MAIN PAGE are defined to Vac1, Vdc1.

### 3.8.2 Save and Recall System Data

The AC Source offers three memory groups for users to save the system data and to recall them for later use. The system data contain all parameters in function lists such as measurement settings, SETUP (see 3.5), CONF (see 3.6) and OUTPUT (see 3.7). In the CHOICE PAGE (see 3.4), press **SHIFT** and **PAGE/EXIT** to run the SAVE function. The displays are shown as below.

**PAGE CHOICE = 1\_**  
**1. SETUP 2.CONF 3.OUTPUT 4. MANUAL CALI**  
**5. LIST 6. PULSE 7.STEP 8. INTERHAR**

**Save all parameters to Group ( 1 - 3 ) : 1\_**

Press **1** - **3** to choose the group to save, then press **ENTER** to confirm. The display will show the saving status message about three seconds as below.

**Save all parameters to Group ( 1 - 3 ) : 1\_**

**Saving now, do not shut down .....**

Then, press **PAGE/EXIT** to return to CHOICE PAGE.



Recalling the system data from memory group is shown as follows. In CHOICE PAGE, press **SHIFT** then **← / -** to run the RECALL function. The display appears as below:



Press **1** - **3** to choose a group to recall, then press **ENTER** to confirm. Then, the display will return to CHOICE PAGE after the data is loaded.

### **ⓘ NOTICE**

The AC Source provides three memory groups: 1, 2, and 3. The memory group 1 keeps the power-on defaults. The setup data saved to memory group 1 will be recalled automatically when the AC Source is powered on again. Those saved in other memory groups must be recalled manually.

## **3.9 Protection**

The AC Source provides protections for software and hardware. When a protection happens, the AC Source will quit the output and turn off the output relays, then show the type of protection on the LCD display. If any protection is triggered to hold the normal output, remove the errors and press **ENTER** to unlock the protection so as to resume the normal operation.

Protections for software are listed as below:

<b>Protection</b>	<b>Description</b>
OVER CURRENT	It occurs when the output current is over the I limit or the current specification.
OVER POWER	It occurs when the output power is over the specification.
OUTPUT OVP	1. It is the feedback for open protection, which means the feedback loop is broken or the output voltage goes wrong. 2. It occurs when the output voltage is over the limit of each RANGE. See 3.3.

Protections for hardware are listed as below:

<b>Protection</b>	<b>Description</b>
FAN FAIL	This fan failure protection that indicates the cooling fan is malfunction.
INT - AD	The inner AD power stage (see 5.1) protection that indicates the output voltage is over or under the specific value.
INT - DD	The inner DD power stage (see 5.1) protection that indicates the output voltage is over or under the specific value.
OUTPUT SHORT	The short protection that indicates the output terminals are shorted.
INPUT FAIL	The power failure protection that indicates the line input voltage is lower or higher than specification.
OVER TEMP	The over temperature protection, which is enabled when the internal temperature of the AC Source is too high.

## 4. Calibration

### 4.1 Introduction

The AC Source built a simple way to calibrate the 3-phase output and measurement accuracy without opening the cover. Users can do it for each phase following the procedures step by step. A voltage meter, current meter, suitable load and +5V DC Source are needed during calibration. Please refer to Figure 4-1 for the connections of these instruments. There are three items need to calibrate. But it is not necessary to calibrate all of them at once. Users can choose one item only as need.

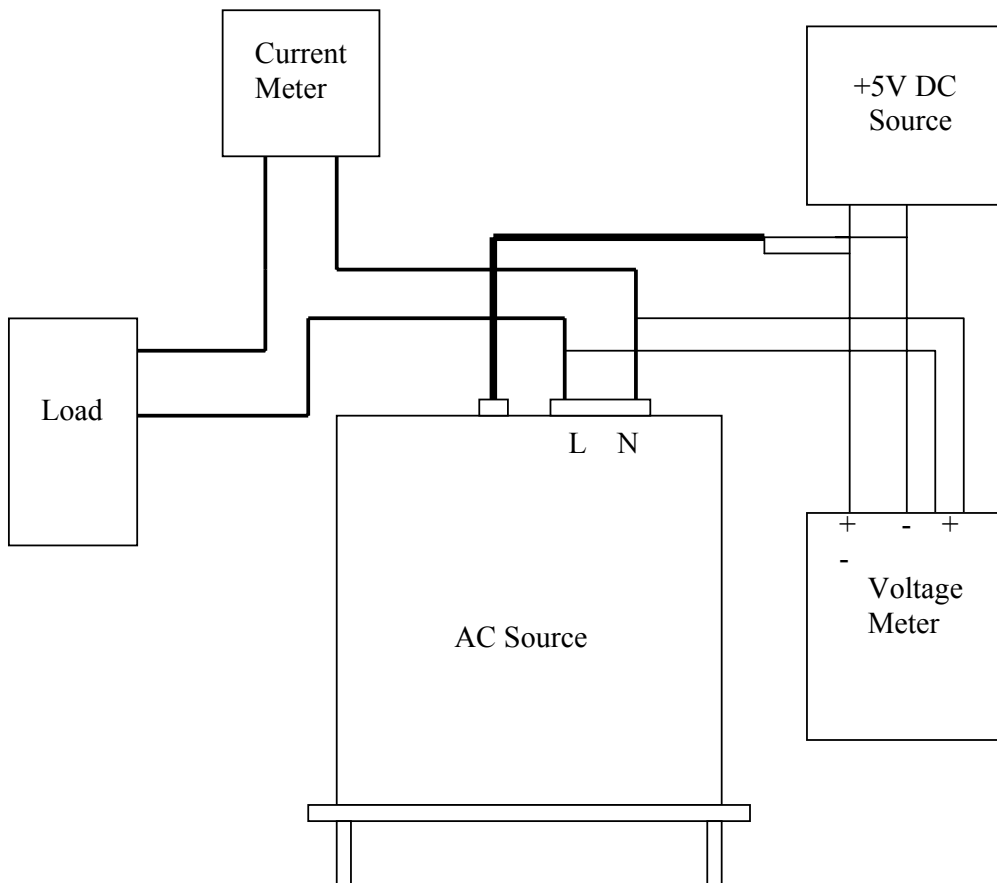

Figure 4-1

## 4.2 MANUAL CALI Functional List

Users can choose "4. MANUAL CALI" in CHOICE PAGE to enter the calibration procedure. Before showing the calibration items, users must enter a password for safety reason. The password is shown in this manual, in order to confirm the users read the manual before performing the calibration.

**PAGE CHOICE = 4\_**

**1. SETUP   2.CONF   3.OUTPUT   4. MANUAL CALI  
5. LIST   6. PULSE   7.STEP   8. INTERHAR**

**Enter Password : \_**

**( You can get password in user's manual ! )**

**Enter Password : \* \* \* \* \_**

**( You can get password in user's manual ! )**

---

### **① NOTICE**

1. The password to enter the calibration procedure is " 7377 ", then press **ENTER**.
  2. Before calibrating the AC Source, users should read the procedures in detail. Or it may lose some data in memory because of improper operation.
- 

After entered the correct Password, the display shows PHASE CHOICE PAGE.

**PAGE CHOICE = 4\_**

**1. SETUP   2.CONF   3.OUTPUT   4. MANUAL CALI  
5. LIST   6. PULSE   7.STEP   8. INTERHAR**

Choose the phase to calibrate, the display shows CALIBRATION CHOICE PAGE.

**CALIBRATION CHOICE = 1\_**  
**1. V OUT AND MEAS.                    2. I MEAS.**  
**3. EXT Vref.**

V OUT AND MEAS.: output voltage and voltage measurement accuracy calibration.  
 I MEAS.: current measurement accuracy calibration.  
 EXT Vref.: external Vref calibration.

### 4.2.1 Output Voltage and Voltage Measurement Calibration

On CALIBRATION CHOICE page, press **1**, **ENTER** to do the output voltage and voltage measurement calibration.

**CALIBRATION CHOICE = 1\_**  
**1. V OUT AND MEAS.                    2. I MEAS.**  
**3. EXT V.**

**Please Remove Load Before Calibrating**  
  
**Press <ENTER> to start**

**1. V OUT AND MEAS. ACCURACY CALI    150V RNG**  
**A. KEYIN THE MEASURED Vdc**  
**Vdc offset = \_                    mV** ▼

In the step A of V OUT AND MEAS. ACCURACY CALI, users should enter the AC Source's DC output voltage measured by digital voltage meter (DVM) in mV. Then, monitor the reading of DVM, keyin the DC output voltage repeatedly until DC output is less than ±10 mV.

**ⓘ NOTICE**

1. The Vdc offset may be positive or negative. The positive of DVM connects to the line of AC Source output, and the negative of DVM connects to the Neutral of AC Source output. See Figure 4-1.
  2. The load must be off at all steps of V OUT AND MEAS. ACCURACY CALI.
- 

Then press **SHIFT**, then **▼** to change to next step.

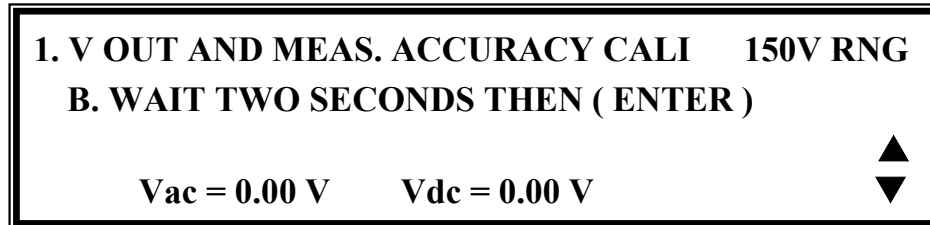

In the step B of V OUT AND MEAS. ACCURACY CALI, the display shows the offset of Vac and Vdc measured by AC Source. They are produced by internal components. Wait two seconds then press **ENTER**, then set Vac = 0.00 and Vdc = 0.00.

**ⓘ NOTICE**

The AC Source calibration steps can be done individually, but it is suggested to follow the calibration procedure step by step (step A, step B ...). Or it may cause output and measurement errors.

---

Press **SHIFT**, then **▼** to change to next step.



In the above step C of V OUT AND MEAS. ACCURACY CALI, users should not turn on the load. Press **ENTER** then check if the output voltage measured by DVM is 15VAC. This step is to make sure the connection is correct.

Then go to step D. Press **ENTER** and check if the output voltage measured by DVM is 150VAC. Keyin the exact value measured by DVM, then press **ENTER**.

Press **SHIFT**, then **▼** to change to next step.

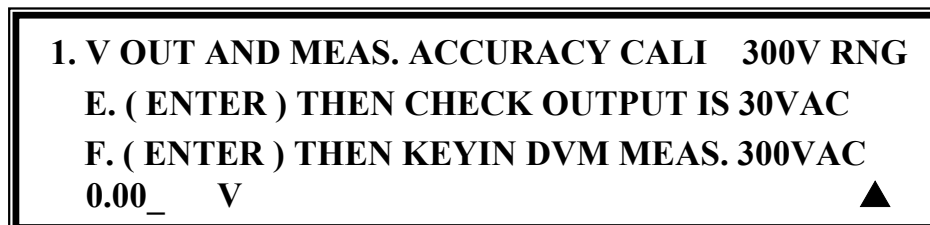

In the above step E of V OUT AND MEAS. ACCURACY CALI, users should not turn on the load. Press **ENTER** and check if the output voltage measured by DVM is 30VAC. This step is to make sure the connection is correct.

Then go to step F. Press **ENTER** and check if the output voltage measured by DVM is 300VAC. Keyin the exact value measured by DVM, then press **ENTER**.

Step F is the final step of V OUT AND MEAS. ACCURACY CALI. Press **PAGE/EXIT** to exit that page. Then display will show as below. Press **ENTER** to save the calibration results.

**Press ( ENTER ) to save .**  
**Press ( PAGE/EXIT ) not to save .**

**ⓘ NOTICE**

1. Users can press **PAGE/EXIT** to exit to the calibration choice page at anytime.
2. See the above display, if **PAGE/EXIT** is pressed without saving the result, the calibration result still works till turning off the power.

## 4.2.2 Current Measurement Calibration

On CALIBRATION CHOICE page, press **2**, **ENTER** to do the current measurement calibration.

**CALIBRATION CHOICE = 2**  
**1. V OUT AND MEAS.            2. I MEAS.**  
**3. EXT Vref.**

**1. CURRENT MEAS. ACCURACY CALI    150V RNG**  
**A. WAIT TWO SECONDS THEN ( ENTER )**

**Iac = 0.00 A      Idc = 0.00 A      ▼**

In the above step A of CURRENT MEAS. ACCURACY CALI, the display shows the offset of Iac and Idc measured by AC Source. They are produced by internal components. Wait two seconds to press **ENTER**, then Iac = 0.00A, Idc = 0.00A.

Press **SHIFT**, then **▼** to change to next step.

**1. CURRENT MEAS. ACCURACY CALI 150V RNG**  
**B. ( ENTER ) THEN CHECK CURRENT IS 1.6A**  
**C. ( ENTER ) THEN KEYIN CURRENT MEAS. 16A**  
**0.00 A ▲**

In the above step B of CURRENT MEAS. ACCURACY CALI, press **ENTER** then AC Source will output 12.5VAC. Users should apply suitable load to output and make the output current measured by current meter (or power analyzer) for about 1.6A (for 61705). The different model shows different current value in display. If the output current is ok after applying load, press **ENTER**, then the AC Source will output 125VAC. The output current will be 10 times of step B, 16A. Keyin the exact value of current measured by current meter. The output currents of step B and step C are shown as below:

Model	Step B	Step C
61705 (12000 VA)	1.6 A	16 A

Step C is the final step of CURRENT MEAS. ACCURACY CALI. Press **PAGE/EXIT** to exit that page. The display will show as below. Press **ENTER** to save the calibration result.

Press ( ENTER ) to save .  
 Press ( PAGE/EXIT ) not to save .

---

**ⓘ NOTICE**

1. The resistance of applied load must be constant, so that the load current is proportional to output voltage. If not, the step B of CURRENT MEAS. ACCURACY will be insignificant. Users only need to meet the current of step C when output voltage is 125VAC.
  2. When performing the calibration, the protection is removed temporarily. It may cause damage to AC Source if applying unsuitable load.
- 

### 4.2.3 External Vref Calibration (Reserved)

On CALIBRATION CHOICE page, press **3**, **ENTER** to do the external Vref calibration. See the details below.



**CALIBRATION CHOICE = 3**  
**1. V OUT AND MEAS.                      2. I MEAS.**  
**3. EXT Vref.**

**Please Remove Load Before Calibrating**

**Press <ENTER> to start**

**3. EXTERNAL Vref CALI                      150V RANGE**  
**A. Vref INPUT SHORT**  
**WAIT TWO SECONDS THEN ( ENTER )**  
**Vdc = 0.00 V**

In the step A of EXTERNAL Vref CALI., short the external Vref input terminal to make input 0V, then the display shows the measured Vdc from AC Source. They are offset voltages produced by internal components. Wait two seconds to press **ENTER**, then Vdc = 0V.

Press **SHIFT**, then **▼** to change to next step.

**3. EXTERNAL Vref CALI                      150V RANGE**  
**B. INPUT EXT. V 5VDC - WAIT TWO SECOND**  
**KEYIN EXT. V DVM MEAS.**  
**0.000                      VDC                      ( ENTER ) ▲**

In the step B of EXTERNAL Vref CALI, users apply +5Vdc to Vref BNC connector from outer DC source. Check if the output voltage of AC Source is 106Vdc, then keyin the exact value of input Vref voltage (not AC Source output) measured from DVM.

Step B is the final step of EXTERNAL Vref CALI. Press **PAGE/EXIT** to exit that page. Then display will show as below. Press **ENTER** to save the calibration result.

**Press ( ENTER ) to save .**  
**Press ( PAGE/EXIT ) not to save .**

## 4.2.4 Phase Angle Calibration

In order to get better accuracy of phase angle among each output voltage, especially at high frequency, 61700 Series AC Sources allow users to calibrate it. Select 4 to go to phase offset calibration at PHASE CHOICE PAGE (see 4.2).

<b>PAGE CHOICE = 1_</b> <b>1. SETUP   2.CONF   3.OUTPUT   4. MANUAL CALI</b> <b>5. LIST   6. PULSE   7.STEP   8. INTERHAR</b>
---

<b>Please Remove Load Before Calibrating!</b>  <b>Press &lt;ENTER&gt; to start</b>
--

Confirm no load is connected and then press **ENTER** to select phase offset calibration.

<b>4. PHASE   OFFSET   CALI.</b> <b>L12Dly= 00.0 us      L13Dly= 00.0 us</b> <b>Vac1=0.00_      Vac2=0.00      Vac3=0.00</b> <b>L12=0.000      L13=0.000</b>
---

L12Dly= 00.0 us and L13Dly= 00.0 us are for reference only.

Step A: Measure the voltage between  $\Phi 1/L$  to N for 50VAC, then keyin the exact value measured by DVM to Vac1 and press **ENTER**.

Step B: Measure the voltage between  $\Phi 2/L$  to N for 50VAC, then keyin the exact value measured by DVM to Vac2 and press **ENTER**.

Step C: Measure the voltage between  $\Phi 3/L$  to N for 50VAC, then keyin the exact value measured by DVM to Vac3 and press **ENTER**.

Step D: Measure the voltage between  $\Phi 1/L$  to  $\Phi 2/L$  for 86.6VAC, then keyin the exact value measured by DVM to L12 and press **ENTER**.

Step E: Measure the voltage between  $\Phi 1/L$  to  $\Phi 3/L$  for 86.6VAC, then keyin the exact value measured by DVM to L13 and press **ENTER**.

Phase offset calibration is finished after the above steps are done. Press **PAGE/EXIT** to exit this page.

**ⓘ NOTICE**

1. The output is 50Vac/400Hz in this calibration procedure. In order to get an accuracy result, please use a high performance DVM such as Agilent 34401A.
  2. The calibration result will keep until powering off the AC Source. Because the phase angle error is different at every time when powering on the AC Source, users must calibrate every time if they want get better accuracy.
-



## 5. Application

### 5.1 General

Not only programming the steady sine output voltage and frequency, the AC Source 61705 also provides several powerful functions to simulate all kinds of power line disturbances. Users can make the output change through a number of value in LIST mode (see 5.2), or make the output change to its set value for a specific period of time in PULSE mode (see 5.3), even make the output change to its set value step by step in STEP mode (see 5.4). With these functions, it is easy to simulate cycle dropout, transient spike, brown out, and etc.

Not only measurements related to power in MAIN PAGE (see 3.3), the AC Source also can achieve interharmonics waveform, a sweeping frequency superimposed on a static fundamental wave (see 5.5).

### 5.2 List Mode (Optional Function)

On CHOICE PAGE (see 3.4), press **5** and **ENTER** to choose the LIST functional list.

PAGE CHOICE = 5_			
1. SETUP	2. CONF	3. OUTPUT	4. MANUAL CALI
5. LIST	6. PULSE	7. STEP	8. INTERHAR

COUPLE = $\Phi 1 + \Phi 2 + \Phi 3$	[ LIST ]
TRIG = AUTO	BASE = TIME
COUNT : 0	
<SHIFT> <ENTER> to Execute ▼	

COUPLE = INDIVIDUAL	EDIT = $\Phi 1$	[ LIST ]
TRIG = AUTO	BASE = TIME	
COUNT : $\Phi 1 = 0$	$\Phi 2 = 0$	$\Phi 3 = 0$
<SHIFT> <ENTER> to Execute ▼		

The waveform programming of LIST mode is the assembly of the SEQUENCES. The output waveform will start from SEQ=0, then SEQ by SEQ. The execution will stop until a SEQ which TIME or CYCLE = 0, even the following SEQs had been set will not be executed.

**COUPLE=INDIVIDUAL/ $\Phi 1 + \Phi 2 + \Phi 3$ :** It sets the output function to individual or dependent mode( $\Phi 1 + \Phi 2 + \Phi 3$ ).

**TRIG=AUTO/MANUAL:** It sets the way to trigger. AUTO: It will finish all COUNT number when triggered. There is only one-way setting when the couple is set individual. MANUAL: It will execute sequence waveform for once only. The phase needs to set to  $\Phi 1 + \Phi 2 + \Phi 3$ . It has the same result in COUNT=1.

**COUNT:** It sets the whole number of times for executing sequences. COUNT = 0: infinity. The source can set each phase count number in individual mode. Otherwise, it sets  $\Phi 1 + \Phi 2 + \Phi 3$  for the same count.

**BASE = TIME / CYCLE:** It sets the unit of sequence length.

Press **SHIFT**, then **▼** to change to next page for sequence programming.

<b>SEQ = 0</b>	<b>DEGREE = 0.0</b>	<b>[<math>\Phi 1</math>] [ LIST ]</b>	
<b>Vs = 0.0</b>	<b>Fs = 60.00</b>	<b>DCs = 0.0</b>	
<b>Ve = 0.0</b>	<b>Fe = 60.00</b>	<b>DCe = 0.0</b>	<b>▲</b>
<b>WAVE = A</b>	<b>TIME = 0.0</b>	<b>ms</b>	<b>▼</b>

<b>SEQ = 1</b>	<b>DEGREE = 0.0</b>	<b>[<math>\Phi 1</math>] [ LIST ]</b>	
<b>Vs = 0.0</b>	<b>Fs = 60.00</b>	<b>DCs = 0.0</b>	
<b>Ve = 0.0</b>	<b>Fe = 60.00</b>	<b>DCe = 0.0</b>	<b>▲</b>
<b>WAVE = A</b>	<b>TIME = 0.0</b>	<b>ms</b>	<b>▼</b>

<b>SEQ = 0</b>		<b>[<math>\Phi 2</math>] [ LIST ]</b>	
<b>Vs = 0.0</b>	<b>Fs = 60.00</b>	<b>DCs = 0.0</b>	
<b>Ve = 0.0</b>	<b>Fe = 60.00</b>	<b>DCe = 0.0</b>	<b>▲</b>
<b>WAVE = A</b>	<b>TIME = 0.0</b>	<b>ms</b>	<b>▼</b>

<b>SEQ = 1</b>	<b>DEGREE = 0.0</b>	<b>[<math>\Phi 2</math>] [ LIST ]</b>	
<b>Vs = 0.0</b>	<b>Fs = 60.00</b>	<b>DCs = 0.0</b>	
<b>Ve = 0.0</b>	<b>Fe = 60.00</b>	<b>DCe = 0.0</b>	<b>▲</b>
<b>WAVE = A</b>	<b>TIME = 0.0</b>	<b>ms</b>	<b>▼</b>

<b>SEQ = 0</b>			<b>[Φ3] [ LIST ]</b>
<b>Vs = 0.0</b>	<b>Fs = 60.00</b>	<b>DCs = 0.0</b>	
<b>Ve = 0.0</b>	<b>Fe = 60.00</b>	<b>DCe = 0.0</b>	▲
<b>WAVE = A</b>	<b>TIME = 0.0</b>	<b>ms</b>	▼

<b>SEQ = 1</b>	<b>DEGREE = 0.0</b>		<b>[Φ3] [ LIST ]</b>
<b>Vs = 0.0</b>	<b>Fs = 60.00</b>	<b>DCs = 0.0</b>	
<b>Ve = 0.0</b>	<b>Fe = 60.00</b>	<b>DCe = 0.0</b>	▲
<b>WAVE = A</b>	<b>TIME = 0.0</b>	<b>ms</b>	▼

**SEQ:** the number of sequence. All sequences must start with zero. The maximal number of SEQ is 99.

**DEGREE:** the phase angle when the sequence starts.

**Vs, Fs, DCs:** the initial waveform when the sequence starts.

**Ve, Fe, DCe:** the final waveform when the sequence ends.

**WAVE = A / B:** the waveform selection (see 3.6.3).

**TIME / CYCLE:** the length of sequence.

After setting sequences, press **PAGE/EXIT** to exit to LIST mode page. Press **SHIFT** and **ENTER** to change to execution page. The LCD shows **\_TRIG\_ON** is under action, and **\* STOP \*** is the triggering status at present. Press **ENTER** to trigger. Then the LCD shows status **\* RUNNING \*** and **TRIG\_OFF** that is waiting for users to stop the LIST waveform output. The LCD shows **\* STOP \*** when the AC Source executed all sequences and **COUNT**.

<b>_TRIG_ON</b>		<b>* STOP *</b>		<b>[ LIST ]</b>
<b>Vrms</b>	<b>Φ1 = 0.00</b>	<b>Φ2 = 0.00</b>	<b>Φ3 = 0.00</b>	▲
<b>I rms</b>	<b>Φ1 = 0.00</b>	<b>Φ2 = 0.00</b>	<b>Φ3 = 0.00</b>	▼

<b>_TRIG_OFF</b>		<b>* RUNNING *</b>		<b>[ LIST ]</b>
<b>Vrms</b>	<b>Φ1 = 0.00</b>	<b>Φ2 = 0.00</b>	<b>Φ3 = 0.00</b>	▲
<b>I rms</b>	<b>Φ1 = 0.00</b>	<b>Φ2 = 0.00</b>	<b>Φ3 = 0.00</b>	▼

On the other hand, Shift Up/Shift Down can be used to choose the desired measurement.

<b>_TRIG_OFF</b>				<b>* RUNNING *</b>		<b>[ LIST ]</b>
<b>Freq</b>	<b>Φ1 = 0.00</b>	<b>Φ2 = 0.00</b>	<b>Φ3 = 0.00</b>			<b>▲</b>
<b>P</b>	<b>Φ1 = 0.000</b>	<b>Φ2 = 0.000</b>	<b>Φ3 = 0.000</b>			<b>▼</b>

<b>_TRIG_OFF</b>				<b>* RUNNING *</b>		<b>[ LIST ]</b>
<b>PF</b>	<b>Φ1 = 0.00</b>	<b>Φ2 = 0.00</b>	<b>Φ3 = 0.00</b>			<b>▲</b>
<b>CF</b>	<b>Φ1 = 0.00</b>	<b>Φ2 = 0.00</b>	<b>Φ3 = 0.00</b>			<b>▼</b>

If the AC Source is running, press **OUT/QUIT** the output will quit waveform to zero voltage. Press **OUT/QUIT** again, the AC Source only outputs the waveform set in MAIN PAGE. Users must press **ENTER** to trigger it again. If in quit state, users can press **ENTER** to output LIST waveform directly.

The programmed LIST mode waveform will shut down when **PAGE/EXIT** is pressed to exit LIST execution page.

LIST mode example:

<b>COUPLE = Φ1 + Φ2 + Φ3</b>				<b>[ LIST ]</b>	
<b>TRIG = AUTO</b>		<b>BASE = TIME</b>			
<b>COUNT=1</b>					
<b>&lt;SHIFT&gt; &lt;ENTER&gt; to Execute</b>					

<b>SEQ = 0</b>		<b>DEGREE = 0.0</b>		<b>[ Φ1 ]</b>	
<b>[ LIST ]</b>					
<b>Vs = 20.0</b>	<b>Fs = 50.00</b>	<b>DCs = 0.0</b>			
<b>Ve = 80.0</b>	<b>Fe = 50.00</b>	<b>DCe = 0.0</b>		<b>▲</b>	

<b>SEQ = 1</b>		<b>DEGREE = 0.0</b>		<b>[ Φ1 ] [ LIST ]</b>	
<b>Vs = 20.0</b>	<b>Fs = 50.00</b>	<b>DCs = 0.0</b>			
<b>Ve = 80.0</b>	<b>Fe = 50.00</b>	<b>DCe = 100.0</b>		<b>▲</b>	
<b>WAVE = A</b>	<b>TIME = 80.0</b>	<b>ms</b>		<b>▼</b>	



<b>SEQ = 2</b>	<b>DEGREE = 0.0</b>	<b>[Φ1] [ LIST ]</b>
<b>Vs = 20.0</b>	<b>Fs = 50.00</b>	<b>DCs = 0.0</b>
<b>Ve = 100.0</b>	<b>Fe = 50.00</b>	<b>DCe = 0.0</b> ▲
<b>WAVE = A</b>	<b>TIME = 100.0</b>	<b>ms</b> ▼

The output waveform :

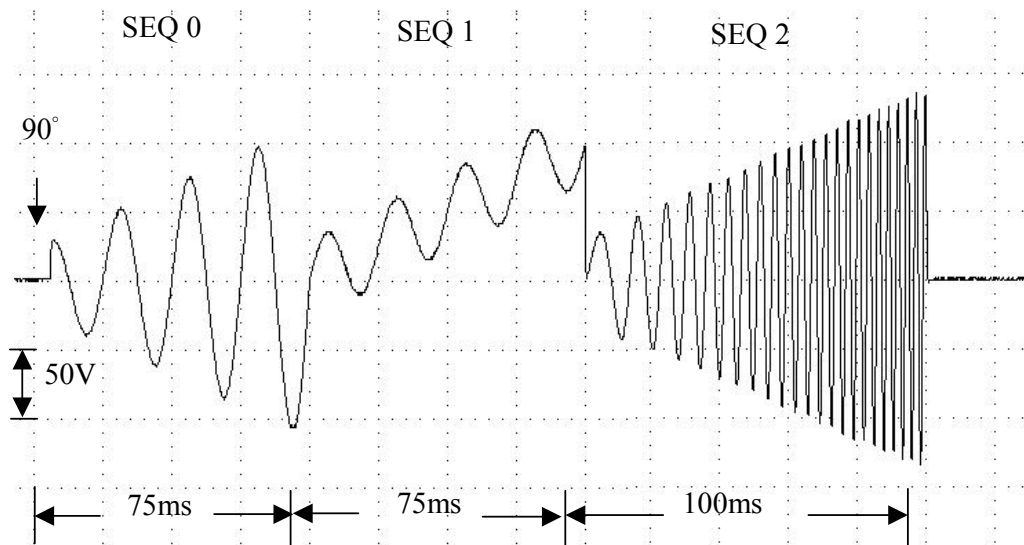

### 5.3 Pulse Mode (Optional Function)

On CHOICE PAGE (see 3.4), press **6** and **ENTER** to choose the PULSE functional list.

```

PAGE CHOICE = 6_
1.SETUP  2.CONF  3.OUTPUT  4. MANUAL CALI
5. LIST  6. PULSE  7. STEP  8. INTERHAR
    
```

```

COUNT=0 [ PULSE ]
Vac = 0.0      F = 60.00      Vdc= 0.0
DUTY = 0.0    % PERIOD = 0.0      ms
                <SHIFT> <ENTER> to Execute ▼
    
```

Press **SHIFT** and **▼** to change to next page.

```

TRIG= AUTO      WAVE=A [PULSE]
DEGREE_Φ1= 0.0
                <SHIFT> <ENTER> to Execute ▲
    
```

The PULSE mode allows users to program a particular waveform ( $\Phi1 + \Phi2 + \Phi3$ ) attach to normal output set in MAIN PAGE. The waveform programming is to specify the duty percentage on top of the programmed output and the transient state.

**COUNT:** the repeat number of pulse.

**Vac, F, Vdc:** the Vac, F and DC output in the duty of period.

**DUTY:** the proportion of pulse in one period.

**PERIOD:** the length of a pulse period.

**TRIG = AUTO / MANUAL:** the way to trigger. AUTO: It will finish all COUNT number when triggered. MANUAL: It will execute pulse waveform for once only. It has the same result in COUNT=1.

**WAVE = A / B:** the waveform selection (see 3.6.3).

**DEGREE\_Φ1:** the output phase angle of Master pulse.

Press **SHIFT** and **ENTER** to go to PULSE execution page. The LCD shows **\_TRIG\_ON** is under action, and **\* STOP \*** is the triggering state at present. Press **ENTER** to trigger it. Then LCD shows **\* RUNNING \*** and **TRIG\_OFF** that is waiting for users to stop the PULSE waveform output. The LCD shows **\* STOP \*** when the AC Source executed all COUNT number.

<b>_TRIG_ON</b>		<b>* STOP *</b>		<b>[ PULSE ]</b>
<b>Vrms</b>	<b>Φ1 = 0.00</b>	<b>Φ2 = 0.00</b>	<b>Φ3 = 0.00</b>	<b>▲</b>
<b>I rms</b>	<b>Φ1 = 0.00</b>	<b>Φ2 = 0.00</b>	<b>Φ3 = 0.00</b>	<b>▼</b>

<b>_TRIG_OFF</b>		<b>* RUNNING *</b>		<b>[ PULSE ]</b>
<b>Vrms</b>	<b>Φ1 = 0.00</b>	<b>Φ2 = 0.00</b>	<b>Φ3 = 0.00</b>	<b>▲</b>
<b>I rms</b>	<b>Φ1 = 0.00</b>	<b>Φ2 = 0.00</b>	<b>Φ3 = 0.00</b>	<b>▼</b>

The source can use Shift Up/Shift Down to choose the desired measurement.

<b>_TRIG_OFF</b>		<b>* RUNNING *</b>		<b>[ PULSE ]</b>
<b>F</b>	<b>Φ1 = 0.00</b>	<b>Φ2 = 0.00</b>	<b>Φ3 = 0.00</b>	<b>▲</b>
<b>P</b>	<b>Φ1 = 0.000</b>	<b>Φ2 = 0.000</b>	<b>Φ3 = 0.000</b>	<b>▼</b>

<b>_TRIG_OFF</b>		<b>* RUNNING *</b>		<b>[ PULSE ]</b>
<b>PF</b>	<b>Φ1 = 0.00</b>	<b>Φ2 = 0.00</b>	<b>Φ3 = 0.00</b>	<b>▲</b>
<b>CF</b>	<b>Φ1 = 0.000</b>	<b>Φ2 = 0.000</b>	<b>Φ3 = 0.000</b>	<b>▼</b>

If the AC Source is in output state, press **OUT/QUIT** the output will quit waveform to zero voltage. If press **OUT/QUIT** again, the AC Source only outputs the waveform set in MAIN PAGE. Users must press **ENTER** to trigger it again. If in quit state, users can press **ENTER** to output PULSE waveform directly.

The pulse wave will shut down when **PAGE/EXIT** is pressed to exit PULSE execution page.

PULSE mode example:

<b>COUNT=3</b>		<b>[ PULSE ]</b>	
<b>Vac = 100.0</b>	<b>F = 50.00</b>	<b>Vdc= 0.0</b>	
<b>DUTY = 35.0 %</b>	<b>PERIOD = 100.0</b>	<b>ms</b>	
<b>&lt;SHIFT&gt; &lt;ENTER&gt; to Execute</b>			<b>▼</b>

**TRIG= AUTO      WAVE=A      [PULSE]**  
**DEGREE\_Φ1= 0.0**  
  
**<SHIFT> <ENTER> to Execute ▲**

The output waveform:

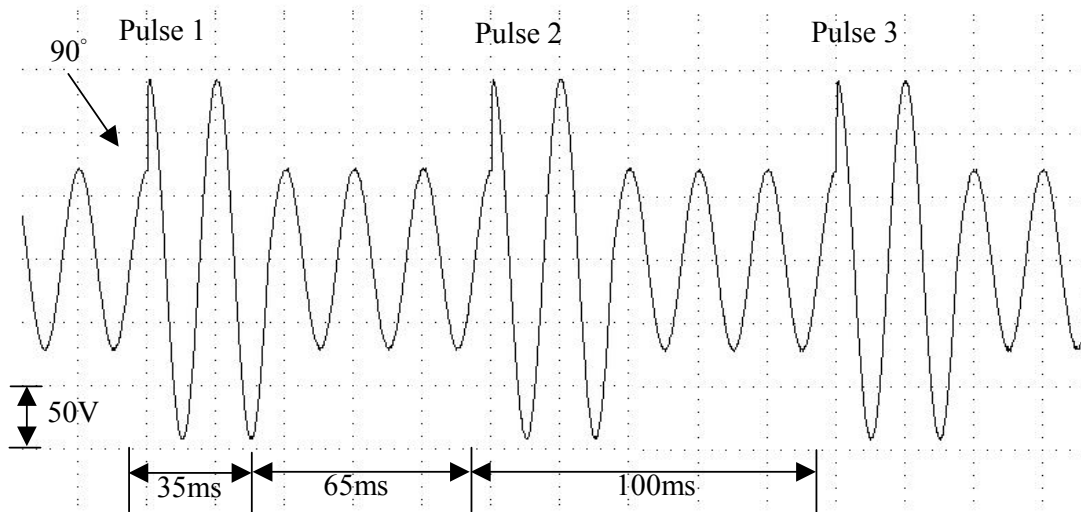

## 5.4 Step Mode (Optional Function)

The STEP mode offers an easy and automatic change function to change output waveform in a regular level and time. But the variation between two steps changes rapidly, not gradually. The waveform programming is to set an initial waveform, specify the dwell time and change of each step, and the number of change step. After execution, the output wave will keep at the last step.

On CHOICE PAGE (see 3.4), press **7** and **ENTER** to choose the STEP functional list.

**PAGE CHOICE = 7\_**  
**1. SETUP   2. CONF   3. OUTPUT   4. MANUAL CALI**  
**5. LIST    6. PULSE   7. STEP    8. INTERHAR**

<b>COUNT = 0</b>	<b>DWELL = 0.0</b>	<b>ms</b>	<b>[ STEP ]</b>
<b>Vac = 0.0</b>	<b>F = 60.00</b>	<b>Vdc = 0.0</b>	
<b>dV = 0.0</b>	<b>dF = 0.00</b>	<b>dDC = 0.0</b>	
<b>&lt;SHIFT&gt; &lt;ENTER&gt; to Execute</b>			<b>▼</b>

<b>TRIG= AUTO</b>	<b>WAVE = A</b>	<b>[STEP]</b>
<b>DEGREE_Φ1 = 0.0</b>		
<b>&lt;SHIFT&gt; &lt;ENTER&gt; to Execute</b>		<b>▲</b>

**COUNT:** the number of each change execution.

**DWELL:** the length of each step.

**Vac, F, Vdc:** the initial value of Vac, F, DC when STEP mode starts to execute.

**dV, dF, dDC:** the difference value of each step. (The negative value is allowed.)

**TRIG = AUTO/MANUAL:** the way to trigger. AUTO: It will finish all COUNT number when triggered. MANUAL: The output waveform will change one step for each execution.

**WAVE = A/B:** the waveform selection (see 3.6.3).

**DEGREE:** the output phase angle of each step.

Press **SHIFT** and **ENTER** to go to STEP execution page. The LCD shows **\_TRIG\_ON** is under action, and **\* STOP \*** is the triggering state at present. Press **ENTER** to trigger it. Then LCD shows **\* RUNNING \*** and **TRIG\_OFF** and **TRIG\_PAUSE**. Press **▲** or **▼** to move the cursor and press **ENTER** to select it. **TRIG\_OFF** is to stop the STEP waveform from changing. **TRIG\_PAUSE** is to keep the STEP waveform until **TRIG\_CONTINUE** is selected. The LCD shows **\* STOP \*** when the AC Source executed all COUNT.

<b>_TRIG_ON</b>	<b>* STOP *</b>			<b>[ STEP ]</b>
<b>Vrms</b>	<b>Φ1 = 0.00</b>	<b>Φ2 = 0.00</b>	<b>Φ3 = 0.00</b>	<b>▲</b>
<b>I rms</b>	<b>Φ1 = 0.00</b>	<b>Φ2 = 0.00</b>	<b>Φ3 = 0.00</b>	<b>▼</b>

<b>_TRIG_OFF</b>	<b>* RUNNING *</b>			<b>[ STEP ]</b>
<b>TRIG_PAUSE</b>				
<b>Vrms</b>	<b>Φ1 = 0.00</b>	<b>Φ2 = 0.00</b>	<b>Φ3 = 0.00</b>	<b>▲</b>
<b>I rms</b>	<b>Φ1 = 0.00</b>	<b>Φ2 = 0.00</b>	<b>Φ3 = 0.00</b>	<b>▼</b>

<b>_TRIG_OFF</b>	<b>* PAUSE *</b>			<b>[ STEP ]</b>
<b>TRIG_CONTINUE</b>				
<b>Vrms</b>	<b>Φ1 = 0.00</b>	<b>Φ2 = 0.00</b>	<b>Φ3 = 0.00</b>	<b>▲</b>
<b>I rms</b>	<b>Φ1 = 0.00</b>	<b>Φ2 = 0.00</b>	<b>Φ3 = 0.00</b>	<b>▼</b>

The source can use Shift Up/Shift Down to choose the desired measurement.

<b>_TRIG_OFF</b>	<b>* RUNNING *</b>			<b>[ STEP ]</b>
<b>TRIG_PAUSE</b>				
<b>F</b>	<b>Φ1 = 0.00</b>	<b>Φ2 = 0.00</b>	<b>Φ3 = 0.00</b>	<b>▲</b>
<b>P</b>	<b>Φ1 = 0.00</b>	<b>Φ2 = 0.00</b>	<b>Φ3 = 0.00</b>	<b>▼</b>

<b>_TRIG_OFF</b>	<b>* RUNNING *</b>			<b>[ STEP ]</b>
<b>TRIG_PAUSE</b>				
<b>PF</b>	<b>Φ1 = 0.00</b>	<b>Φ2 = 0.00</b>	<b>Φ3 = 0.00</b>	<b>▲</b>
<b>CF</b>	<b>Φ1 = 0.00</b>	<b>Φ2 = 0.00</b>	<b>Φ3 = 0.00</b>	<b>▼</b>

If the AC Source is in output state, press **OUT/QUIT** the output will quit waveform to zero voltage. If press **OUT/QUIT** again, the AC Source only outputs the waveform set in MAIN PAGE. Users must press **ENTER** to trigger it again. If in quit state, users can press **ENTER** to output STEP waveform directly.

The STEP wave will stop executing when **PAGE/EXIT** is pressed to exit STEP execution page. When **TRIG = MANUAL**, the LCD shows TRIG\_UP and TRIG\_DOWN. The output waveform will change to the next step if TRIG\_UP is selected. If TRIG\_DOWN is selected the output waveform will change back to the last step.

<b>_TRIG_UP</b>	<b>* STOP *</b>			<b>[ STEP ]</b>
<b>TRIG_DOWN</b>				
<b>Vrms</b>	<b>Φ1 = 0.00</b>	<b>Φ2 = 0.00</b>	<b>Φ3 = 0.00</b>	<b>▲</b>
<b>I rms</b>	<b>Φ1 = 0.00</b>	<b>Φ2 = 0.00</b>	<b>Φ3 = 0.00</b>	<b>▼</b>

STEP mode example:

<b>COUNT = 3</b>	<b>DWELL = 60.0</b>	<b>ms</b>	<b>[ STEP ]</b>
<b>Vac = 40.0</b>	<b>F = 50.00</b>	<b>Vdc = 0.0</b>	
<b>dV = 10.0</b>	<b>dF = 50.00</b>	<b>dDC = 20.0</b>	
<b>&lt;SHIFT&gt; &lt;ENTER&gt; to Execute</b>			<b>▼</b>

**TRIG= AUTO      WAVE = A      [STEP]**  
**DEGREE\_Φ1 = 0.0**  
  
**<SHIFT> <ENTER> to Execute      ▲**

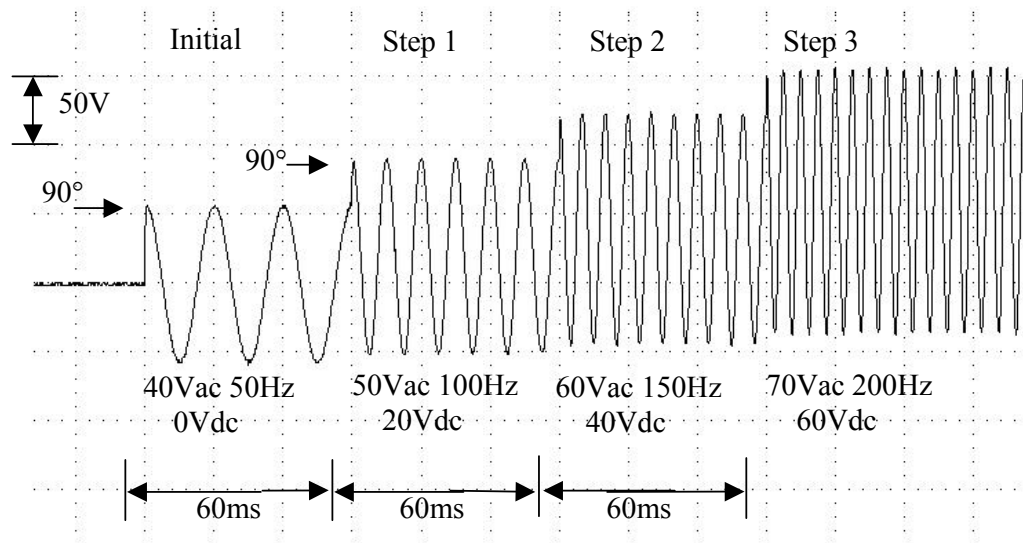

## 5.5 Interharmonics Waveform (Optional Function)

On CHOICE PAGE (see 3.4), press **8** and **ENTER** to choose the INTERHAR functional list.

**PAGE CHOICE = 8\_**  
**1. SETUP   2. CONF   3. OUTPUT   4. MANUAL CALI**  
**5. LIST    6. PULSE   7. STEP    8. INTERHAR**

**EXE\_MODE= Φ1 + Φ2 + Φ3      [ INTERHAR ]**  
**Fi\_start = 0.01   Hz      Fi\_end = 2400.0   Hz**  
**LEVEL = 0.0   %      TIME = 0.00   sec**  
**<SHIFT> <ENTER> to Execute**

For some tests, the AC Source offers a sweeping frequency with a small magnitude level that can superimpose on original fundamental output in INTERHAR function.

**EXE\_MODE** =  $\Phi 1 + \Phi 2 + \Phi 3/\Phi 1/\Phi 2/\Phi 3$ : it sets the output phase. There are 4 modes for selection.

**Fi\_start**: the starting frequency of the sweeping wave. The range is 0.01Hz ~ 2400Hz.

**Fi\_end**: the ending frequency of the sweeping wave. The range is 0.01Hz ~ 2400Hz.

**LEVEL**: the r.m.s. magnitude of the sweeping wave in percentage of fundamental voltage set in MAIN PAGE.

**TIME**: the time interval from Fi\_start to Fi\_end.

Press **SHIFT** and **ENTER** to go to INTERHAR execution page. The LCD shows **\_TRIG\_ON** is under action, and **\* STOP \*** is the triggering state at present. Fi is the sweeping frequency. (Fi=0 means no sweeping wave superimpose on original fundamental output.) Press **ENTER** to trigger it. Then LCD shows **\* RUNNING \*** and **TRIG\_OFF** and **TRIG\_PAUSE**. Press **▲** or **▼** to move the cursor and press **ENTER** to select it. **TRIG\_OFF** is to stop the INTERHAR waveform. **TRIG\_PAUSE** is to pause the INTERHAR waveform at certain frequency. The frequency will continue to sweep when users move the cursor to **TRIG\_CONTINUE** and press **ENTER**. The LCD shows **\* FINISH \*** when the sweeping frequency reaches to Fi\_end.

<b>_TRIG_ON</b>		<b>* STOP *</b>		<b>[ INTERHAR ]</b>	
				<b>Fi = 0.00</b>	
<b>Vrms</b>	<b>Φ1 = 0.00</b>	<b>Φ2 = 0.00</b>	<b>Φ3 = 0.00</b>		<b>▲</b>
<b>I rms</b>	<b>Φ1 = 0.00</b>	<b>Φ2 = 0.00</b>	<b>Φ3 = 0.00</b>		<b>▼</b>

<b>_TRIG_OFF</b>		<b>* RUNNING *</b>		<b>[ INTERHAR ]</b>	
<b>TRIG_PAUSE</b>				<b>Fi = 0.00</b>	
<b>Vrms</b>	<b>Φ1 = 0.00</b>	<b>Φ2 = 0.00</b>	<b>Φ3 = 0.00</b>		<b>▲</b>
<b>I rms</b>	<b>Φ1 = 0.00</b>	<b>Φ2 = 0.00</b>	<b>Φ3 = 0.00</b>		<b>▼</b>

<b>_TRIG_OFF</b>		<b>* PAUSE *</b>		<b>[ INTERHAR ]</b>	
<b>TRIG_CONTINUE</b>				<b>Fi = 0.00</b>	
<b>Vrms</b>	<b>Φ1 = 0.00</b>	<b>Φ2 = 0.00</b>	<b>Φ3 = 0.00</b>		<b>▲</b>
<b>I rms</b>	<b>Φ1 = 0.00</b>	<b>Φ2 = 0.00</b>	<b>Φ3 = 0.00</b>		<b>▼</b>

If the AC Source is in output state, press **OUT/QUIT** the output will quit to zero voltage. If press **OUT/QUIT** again, the AC Source only outputs the waveform set in MAIN PAGE. Users must press **ENTER** to trigger it again. If in quit state, users can press **ENTER** to output interharmonics waveform directly.



The INTERHAR waveform will shut down when **PAGE/EXIT** is pressed to exit INTERHAR execution page.

---

**ⓘ NOTICE**

For practical use and to protect the power stage of AC Source, the LEVEL has to be restricted to  $F_{i\_start}$  and  $F_{i\_end}$ :

If  $0.01\text{Hz} \leq F_{i\_start}$  or  $F_{i\_end} \leq 500\text{Hz}$ ,  $\text{LEVEL} \leq 30\%$ .

If  $500\text{Hz} < F_{i\_start}$  or  $F_{i\_end} \leq 1000\text{Hz}$ ,  $\text{LEVEL} \leq 20\%$ .

If  $1000\text{Hz} < F_{i\_start}$  or  $F_{i\_end} \leq 2400\text{Hz}$ ,  $\text{LEVEL} \leq 10\%$ .

---



## 6. Theory of Operation

### 6.1 Description of Overall System

Figure 6-1 shows the overall system. Main power flows through 3 modules of power transfer unit. The A board is identified as user interface controller. It scans the front panel keys through K board, and sends the settings and measurement messages to LCD module. The optional E board performs remote control via GPIB or RS-232C interface.

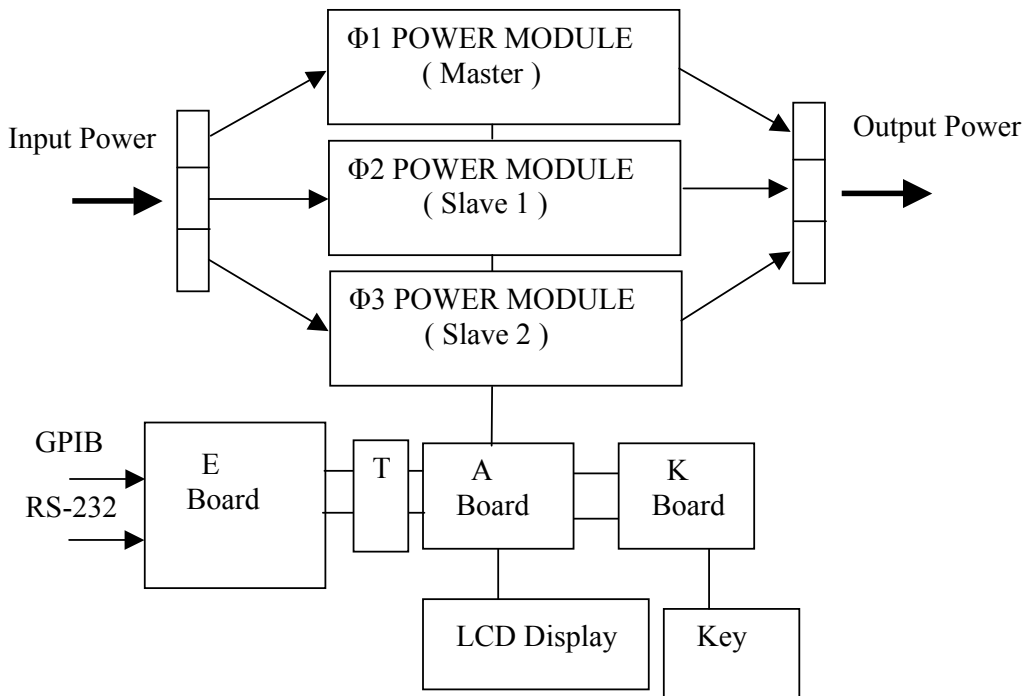

Figure 6-1 The Structure of 61700 Series AC Source

### 6.2 Description of Power Transfer Unit

Figure 6-2 shows the power transfer unit. The A/D power stage is designated as I board, and generates DC voltage from the line input. The G board of D/D stage takes power from the A/D output. It generates two isolated DC outputs for D/A power stage. The H board of D/A inverter generates AC output. The D/A power stage is through G board relays in parallel or series control to obtain more current and higher voltage. B board is identified as DSP processor and D/A controller. The DSP processor is applied to control output frequency and voltage as well as to measure voltage and current.

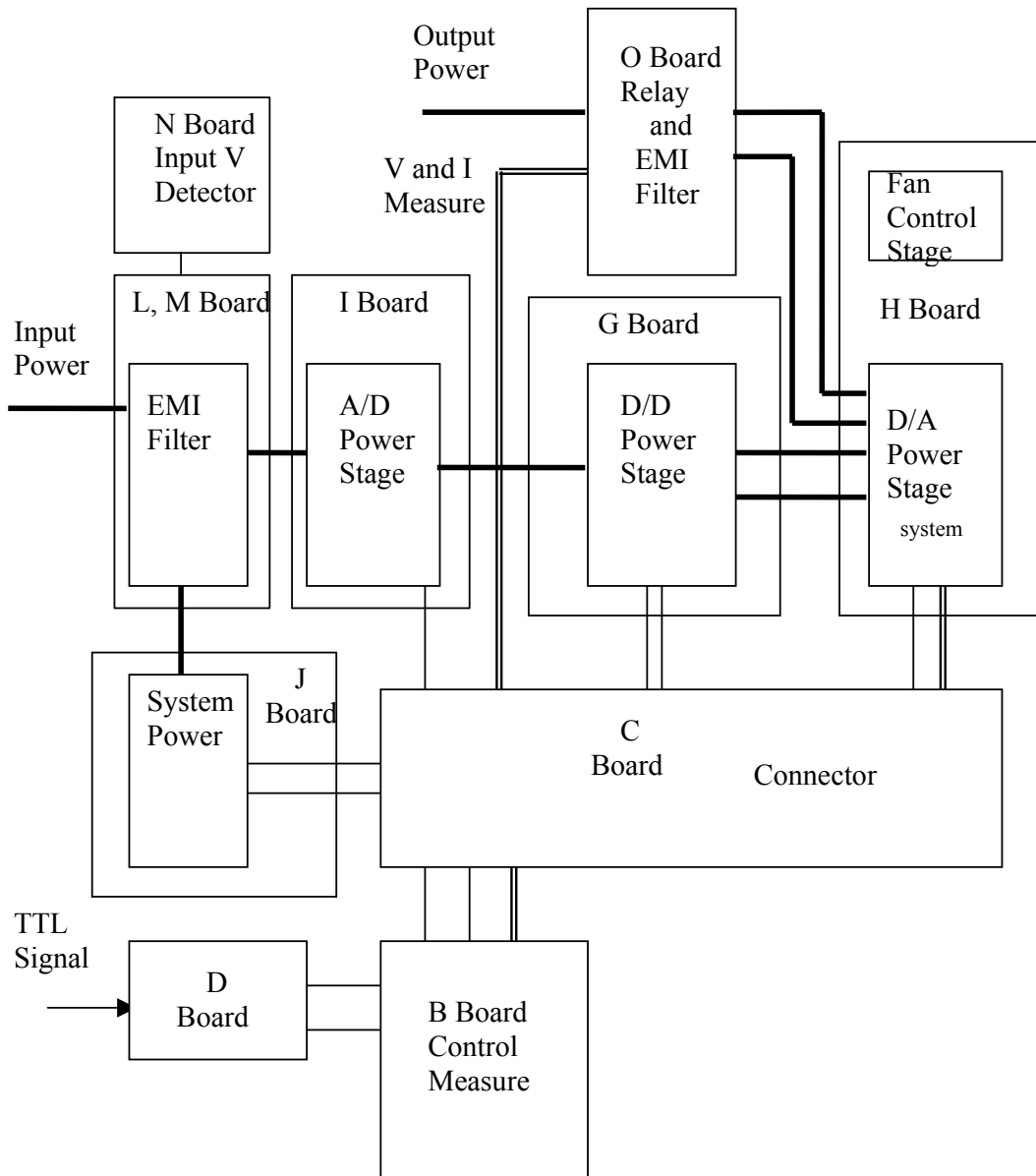

Figure 6-2 The Structure of Power Transfer Unit

## 7. Self-test and Troubleshooting

### 7.1 General

This section describes the self-test steps and suggested troubleshooting procedures when AC Source is not functioning normally. If the problem cannot be solved using the information given here, consult with the distributor whom you purchased the unit.

### 7.2 Self-test

The AC Source performs a series of self-tests at power-on. First, it does the memory, data and communication self-test. There are three items: DISPLAY, WAVEFORM, and REMOTE. If any failure is detected on a certain item, an “error code” will be shown at the right side of that item. The following table shows all of the error messages:

Error Code	Description	Remark
Bit 0	SRAM error	0 – OK, 1 - ERROR
Bit 1	CODE error	0 – OK, 1 – ERROR
Bit 2	DATA error	0 – OK, 1 – ERROR
Bit 3	Communication error	0 – OK, 1 - ERROR
Bit 4	Output test result	0 – OK, 1 – ERROR
Bit 5	Reserved	
Bit 6	Reserved	
Bit 7	Reserved	

Example: If an error code shows “ERROR = 05”, the error code is “00000101” in binary. The bit 0 and bit 2 are “1”. So “ERROR = 05” means SRAM error and DATA error occurs.

Error Message	Description	Action
SRAM error	SRAM test fail	Consult your dealer for assistance.
CODE error	Program code test fail	Consult your dealer for assistance.
DATA error	Data in Flash or EEPROM test fail	Consult your dealer for assistance.
Communication error	Cannot communicate	1. Power off the AC Source and wait for three seconds to power it on again. 2. Consult your dealer for assistance.

After the self-test of memory, data and communication, the AC Source performs the power output self-test. In this procedure, the output relays are OFF to ensure the load connecting on output terminal is not harmed. Then, the AC Source will check if there is any protection signal sent from the hardware. If it does, the display shows "Output self test <NG>". It means the AC Source is abnormal. Press **ENTER** to see what type of protection it is. If there is no protection signal, the AC Source will program 300Vac and measure the voltage.

If the measured voltage is over  $300V \pm 5V$ , the power self-test is failed, and the display shows " Output self test <NG> ". Probably AC Source has not been calibrated (updated the software especially). Users can do the following steps to reassure it.

1. Press **ENTER** to ignore the NG.
2. If there is no PROTECTION, press **PAGE/EXIT** to change to MAIN PAGE.
3. Program a small voltage such as 10Vac and press **OUT/QUIT**, see the measurement from LCD display if V is 10V or not.

If the reading of V is around 10V, the AC Source needs to be calibrated (see Chapter 4). If the reading does not change obviously or shows an unreasonable value or display shows PROTECTION, the AC Source has some problems. Consult your dealer for assistance.

## 7.3 Troubleshooting

The following table lists the operating problems and suggested corrective actions:

Problem	Reason	Solution
Poor measurement of V, I.	Aging of components result in deviation of characteristics.	Periodic calibration is required. Refer to Chapter 4 <i>Calibration</i> .
Distorted output	<ol style="list-style-type: none"> <li>1. The AC Source output voltage is too low.</li> <li>2. The rectified load is too large at high frequency.</li> </ol>	<ol style="list-style-type: none"> <li>1. Program higher output voltage.</li> <li>2. Reduce the load or lower than the output frequency.</li> </ol>
OVER TEMP protection (OTP)	<ol style="list-style-type: none"> <li>1. Ambient temperature is too high.</li> <li>2. Airway is obstructed.</li> </ol>	<ol style="list-style-type: none"> <li>1. Operate the unit in <math>0 \sim 40^{\circ}\text{C}</math>.</li> <li>2. Unblock the airway.</li> </ol>
OVER POWER protection (OPP)	The output power is over specification.	Remove the over power or lower down output voltage.
OVER CURRENT protection (OCP)	The output current is over specification or I LIMIT.	Remove the overload or relax the I LIMIT.
OUTPUT SHORT protection	<ol style="list-style-type: none"> <li>1. The output is shorted.</li> <li>2. External current reverse.</li> </ol>	<ol style="list-style-type: none"> <li>1. Remove the short.</li> <li>2. Remove the load.</li> </ol>
INPUT FAIL protection (UVP)	The AC Source line input voltage is too low or too high.	Measure the input voltage, and regulate it if it is over specification.
INT _ AD protection	<ol style="list-style-type: none"> <li>1. Line input voltage cycle dropout.</li> <li>2. Instant over current of output.</li> <li>3. AD power stage damaged.</li> </ol>	<ol style="list-style-type: none"> <li>1. Check the stability of input voltage.</li> <li>2. Remove the load.</li> <li>3. If cannot reset the protection state, consult the dealer for assistance.</li> </ol>
INT _ DD protection	<ol style="list-style-type: none"> <li>1. Line input voltage cycle dropout.</li> <li>2. Instant over current of output.</li> <li>3. DD power stage damaged.</li> </ol>	<ol style="list-style-type: none"> <li>1. Check the stability of input voltage.</li> <li>2. Remove the load.</li> <li>3. If cannot reset the protection state, consult the dealer for assistance.</li> </ol>

<b>Problem</b>	<b>Reason</b>	<b>Solution</b>
OUTPUT OVP protection	<ol style="list-style-type: none"><li>1. Remote sense is open.</li><li>2. Output voltage peak is over range.</li></ol>	<ol style="list-style-type: none"><li>1. Connect the output to remote sense terminals.</li><li>2. Check the settings of Vac and Vdc on MAIN PAGE.</li></ol>
Cannot control AC Source by GPIB	<ol style="list-style-type: none"><li>1. The AC Source unit address is incorrect.</li><li>2. GPIB cable is loose at rear.</li></ol>	<ol style="list-style-type: none"><li>1. Update the unit address.</li><li>2. Check the connection and tighten the screws.</li></ol>





## 8. Remote Operation

### 8.1 General Information

The AC Source can be controlled remotely through the GPIB or the RS-232C port. The GPIB port is mostly used, but the RS-232C port is helpful too.

Technically speaking, the GPIB interface is quite different from the RS-232C interface. The GPIB interface is an 8-bit parallel data bus owning a host of bus commands for synchronization, and up to one Megabyte transfer rate. The RS-232C interface, a series bus with a few handshake lines for synchronization, is less capable, so its requirement is not so much, and users can write a simple program to do basic remote control easily.

#### 8.1.1 Setting the GPIB Address and RS-232C Parameters

The AC Source is shipped with the GPIB address which is set to 30. The address can be changed from the “CONF” functional list menu (refer to 3.6.3) only. This menu is also used to select the RS-232C interface, and specify the parameters of RS-232C such as baud rate and parity.

#### 8.1.2 Wire Connection of RS-232C

The AC Source is shipped with the baud rate which is set to 19200, and with parity which is set to None. For RS-232C interface, only the signals of TxD and RxD are used for its transferring of data. The RS-232C connector is a 9-pin D subminiature female connector. The following table describes the pins and signals of RS-232C connector.

Pin No.	Input/Output	Description
1	---	No connection
2	OUTPUT	TxD
3	INPUT	RxD
4	---	No connection
5	---	GND
6	---	No connection
7	---	No connection
8	---	No connection
9	---	No connection

Interconnection between the computer (compatible with IBM PC) and the AC Source is illustrated below:

PIN	IBM PC	AC Source
1	DCD	No Connection
2	RX ←	TX
3	TX →	RX
4	DTR	No Connection
5	GND	GND
6	DSR	No Connection
7	RTS	No Connection
8	CTS	No Connection
9	RI	No Connection

## 8.2 The GPIB Capability of the AC Source

GPIB Capability	Description	Interface Functions
Talker/Listener	Commands and response messages can be sent and received over the GPIB bus. Status information can be read using a series poll.	AH1, SH1, T6, L4
Service Request	The AC Source sets the SRQ line true if there is an enabled service request condition.	SR1
Remote/Local	The AC Source powers up in local state. In local state, the front panel is operative, and the AC Source responds to the commands from GPIB. In remote state*, all front panel keys except the “<PAGE/EXIT>” key are disabled. Press “<PAGE/EXIT>” key to return the AC Source to local state.	RL1

\*Remote State:

The panel shows remote message on the LCD display as below:

Vac = 0.0_				R H
Freq = 60.00			Pt = 0.0	
Vrms	Φ1 = 0.00	Φ2 = 0.00	Φ3 = 0.00	▲
I rms	Φ1 = 0.00	Φ2 = 0.00	Φ3 = 0.00	▼

In remote state, all front panel keys except the “<PAGE/EXIT>” key are disabled. Press the “<PAGE/EXIT>” key to return the AC Source to the local state.

## 8.3 Introduction to Programming

All commands and response messages are transferred in form of ASCII codes. The response messages must be read completely before a new command is sent, otherwise the remaining response messages will be lost, and a query interrupt error will occur.

### 8.3.1 Conventions

Angle brackets	< >	Items in angle brackets are parameter abbreviations.
Vertical bar		Vertical bar separates alternative parameters.
Square brackets	[ ]	Items in square brackets are optional. For example, OUTP [ : STATE] means that : STATE may be omitted.
Braces	{ }	Braces indicate the parameters that may be repeated. The notation <A> {<, B>} means that parameter "A" must be entered while parameter "B" may be omitted or entered once or more times.

### 8.3.2 Numerical Data Formats

All data programmed to or returned from the AC Source are ASCII. The data can be numerical or character string.

#### Numerical Data Formats

Symbol	Description	Example
NR1	It is a digit with no decimal point. The decimal is assumed to be at the right of the least significant digit.	123, 0123
NR2	It is a digit with a decimal point.	12.3, .123
NR3	It is a digit with a decimal point and an exponent.	1.23E+2

### 8.3.3 Boolean Data Format

The Boolean parameter <Boolean> has the form ON|OFF only.

### 8.3.4 Character Data Format

The character strings returned by query command may take either of the following forms:

<CRD>	Character Response Data: character string with maximum length of 12.
<SRD>	String Response Data: character string.

### 8.3.5 Basic Definition

#### **Command Tree Table:**

The commands of the AC Source are based on a hierarchical structure, also known as a tree system. In order to obtain a particular command, the full path to that command must be specified. This path is represented in the table by placing the highest node in the farthest left position of the hierarchy. Lower nodes in the hierarchy are indented in the position to the right, below the parent node.

#### **Program Headers:**

Program headers are key words that identify the command. They follow the syntax described in subsection 8.6 of IEEE 488.2. The AC Source accepts characters in both upper and lower case without distinguishing the difference. Program headers consist of two distinctive types, common command headers and instrument-controlled headers.

#### **Common Command and Query Headers:**

The syntax of common command and query headers is described in IEEE 488.2. It is used together with the IEEE 488.2-defined common commands and queries. The commands with a leading “ \* ” are common commands.

#### **Instrument-Controlled Headers:**

Instrument-controlled headers are used for all other instrument commands. Each of them has a long form and a short form. The AC Source only accepts the exact short and long forms. A special notation will be taken to differentiate the short form header from the long one of the same header in this subsection. The short forms of the headers are shown in characters of upper case, whereas the rest of the headers are shown in those of lower case.

#### **Program Header Separator (:):**

If a command has more than one header, the user must separate them with a colon (FETC:CURR?, VOLT:DC 10). Data must be separated from program header by one space at least.

#### **Program Message:**

Program message consists of a sequence of zero or more elements of program message unit that is separated by separator elements of program message unit.

#### **Program Message Unit:**

Program message unit represents a single command, programming data, or query.

Example: `FREQ?, OUTPut ON.`

#### **Program Message Unit Separator ( ; )::**

The separator (semicolon ;) separates the program message unit elements from one another in a program message.

Example: `VOLT:AC 110 ; FREQ 120<PMT>`

**Program Message Terminator (<PMT>):**

A program message terminator represents the end of a program message. Three permitted terminators are:

- (1) <END>: end or identify (EOI)
- (2) <NL>: new line which is a single ASCII-encoded byte 0A (10 decimals).
- (3) <NL> <END>: new line with EOI.

**Note:** The response message is terminated by <NL> <END> for GPIB, and <NL> for RS-232C.

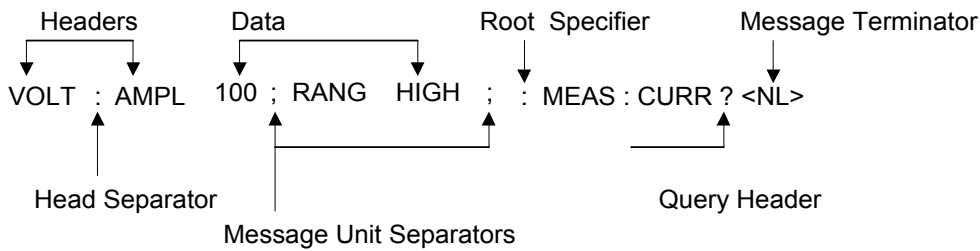

Figure 8-1 The Structure of Command Message

**8.4 Traversal of the Command Tree**

Multiple program message unit elements can be sent in a program message. The first command is always referred to the root node. Subsequent commands are referred to the same tree level as the previous command in a program message. A colon preceding a program message unit changes the header path to the root level.

Example:

OUTPut : PROTection : CLear	All colons are header separators.
: OUTPut : PROTection : CLear	Only the first colon is a specific root.
OUTPut : PROTection : CLear; : VOLT : AC 100	Only the third colon is a specific root.

**8.5 The Execution Order**

The AC Source executes program messages by the order received. Program message units except coupled commands are executed in order of reception. The execution of coupled commands is deferred until program message terminator is received. A coupled command sets parameters which are affected by the setting of other commands. Problems may arise, because the prior state of the AC Source will affect the response of a coupled parameter to its programming.

For example, assume that the current output voltage range is LOW, a new state is desired with output voltage range HIGH, and amplify 220 Volt. If the commands

```
VOLTage : AC      220<PMT>
VOLTage : RANGE  HIGH<PMT>
```

are sent, data out of range error will be produced. Reversing the order, or sending the commands in one program message can avoid such kind of error. For the above example, the program message

```
VOLTage : AC 220 ; VOLTage : RANGE HIGH<PMT>
```

can be sent without error.

## 8.6 The Commands of the AC Source

This subsection is going to talk about the syntax and parameters for all commands of the AC Source. The examples given for each command are generic.

Syntax Forms	Definitions of syntax are in long form headers, whereas only short form headers appear in examples.
Parameters	Most commands require a parameter.
Return Parameters	All queries return a parameter.
Models	If a command is merely applied to specific models, these models will be listed in the Model only entry. If there is no Model only entry, the command will be applied to all models.

### 8.6.1 Common Command Dictionary

Common commands begin with a "\*", and consist of three letters and/or one "?" (query). Common commands and queries are listed alphabetically.

*CLS	Clear status This command clears the following registers. (1) Questionable Status Event (2) Status Byte (3) Error Queue
*ESE<n>	Standard event status enabled This command programs the Standard Event register bits. If one or more of the enabled events of the Standard Event register is set, the ESB of Status Byte Register is set too.

## Bit Configuration of Standard Event Status Enabled Register

Bit Position	7	6	5	4	3	2	1	0
Bit Name	PON	---	CME	EXE	DDE	QYE	---	OPC
CME = Command error				DDE = Device-dependent error				
EXE = Execution error				OPC = Operation complete				
PON = Power-on				QYE = Query error				

- \*ESE? Return standard event status enabled  
The query reads the Standard Event Status Event register. Reading of the register clears it. The bits of configuration are the same as Standard Event Status Enabled Register.
- \*IDN? Return the AC Source identification string  
Return Parameter Chroma ATE 61700,123456,1.00,1.01,1.02  
Chroma ATE : Company name  
61700 : Model name  
123456 : Serial number  
1.00, 1.01,1.02 : Firmware version of display, waveform and remote
- \*RCL<n> Restore the values of the specific group which is previously stored in memory.  
Parameter 1 - 3
- \*RST This command resets the AC Source to the initial states. It's better to wait about 3 second to send the next command.
- \*SAV<n> Save the values into the specific group in memory.  
Parameter 1 - 3
- \*SRE This command sets conditions of the Service Request Enabled Register. If one or more of the enabled events of the Status Byte Register is set, the MSS and RQS of Status Byte Register are set too.
- \*SRE? This query returns the Service Request Enabled Register.
- \*STB? This query returns the Status Byte Register.  
Bit configuration of Status Byte Register
- | Bit Position | 7  | 6          | 5   | 4   | 3    | 2  | 1  | 0  |
|--------------|----|------------|-----|-----|------|----|----|----|
| Condition    | -- | MSS<br>RQS | ESB | MAV | QUES | -- | -- | -- |
- ESB = event status byte summary  
QUES = questionable status summary  
RQS = request for service  
MSS = master status summary  
MAV = message available
- \*TST? This command queries the self-test result of the AC Source.

## 8.6.2 Instrument Command Dictionary

The commands are listed in alphabetical order. Commands followed by question marks (?) take only the query forms. When commands take both the command and query forms, they are noted in the query syntax descriptions.

### 8.6.2.1 SYSTEM Sub-system

#### SYSTem

- : ERRor?
- : VERSion?
- : LOCal
- : REMote

#### SYSTem : ERRor?

- Description : This command queries the error string of the command parser.
- Query Syntax : SYSTem : ERRor?
- Parameters : NONE
- Return Parameters : Response error string: No Error  
Data Format Error  
Data Range Error  
Too Many Errors  
Execution Error

#### SYSTem : VERSion?

- Description : This query requests the AC Source to identify itself.
- Query Syntax : SYSTem : VERSion?
- Parameters : NONE
- Return Parameters :

#### SYSTem : LOCAl

- Description : This command can only be used under the control of RS-232C. If SYST: LOC is programmed, the AC Source will be set in the LOCAL state, and the front panel will work.
- Query Syntax : NONE
- Parameters : NONE
- Return Parameters : NONE

#### SYSTem : REMote

- Description : This command can only be used under the control of RS-232C. If SYST: REM is programmed, the AC Source will be set in the REMOTE state, and the front panel will be disabled except the "<PAGE/EXIT> key.
- Query Syntax : NONE
- Parameters : NONE
- Return Parameters : NONE



### 8.6.2.2 INSTRUMENT Sub-system

#### INSTrument

: COUPle  
 : NSElect  
 : SElect  
 : PHASe  
     : SLAVE1  
     : SLAVE2

#### INSTrument : COUPle

Description : In a multi-phase power source it is convenient to set parameters for all phases simultaneously with one programmed command. When INST: COUP ALL command is programmed, a command will be sent to the AC Source, and to all phases in the end. INST: COUP NONE command cancels COUP ALL command. This command affects the set voltage only.

Query Syntax : INSTRument : COUPle?  
 Parameters : ALL | NONE  
 Return Parameters : NONE

#### INSTrument : NSElect

Description : This command sets individual outputs in a multi-phase model for subsequent commands or queries. If INST: COUP NONE is programmed, the phase-selective commands are sent to the particular output phase set by INSTRument: NSElect. If INST: COUP ALL is programmed, all Remote Operation commands are sent to all output phases. This command affects the set voltage and queries measurement data. For example, if “INST: COUP ALL”, “INST : NSEL 2” and “Meas : V?” are programmed, the AC Source will return  $\Phi 2$ 's measured voltage. INST: NSEL selects phase by number.

Query Syntax : INSTRument : NSElect?  
 Parameters : 1 | 2 | 3  
 Return Parameters : 1 | 2 | 3

#### INSTrument : SElect

Description : This command sets individual outputs in a multi-phase model for subsequent commands or queries. If INST: COUP NONE is programmed, the phase-selective commands are sent to the particular output phase set by INSTRument: SElect. If INST: COUP ALL is programmed, all Remote Operation commands are sent to all output phases. This command affects the set voltage and queries measurement data. For example, if “INST: COUP ALL”, “INST: SEL OUTPUT2” and “Meas: V?” are programmed, the AC Source will return  $\Phi 2$ 's measured voltage. INST: SElect selects phase by name.

Query Syntax : NONE

Parameters : OUTPUT1 | OUTPUT2 | OUTPUT3  
 Return Parameters : NONE

#### INSTrument : PHASe : SLAVE1

Description : This command sets the phase shift between  $\Phi 1$  and  $\Phi 2$ . The default value is 120 degree.  
 Query Syntax : INSTrument : PHASe : SLAVE1?  
 Parameters : <NR1>, valid range: 0 ~ 359.9  
 Return Parameters : <NR1>

#### INSTrument : PHASe : SLAVE2

Description : This command sets the phase shift between  $\Phi 1$  and  $\Phi 3$ . The default value is 240 degree.  
 Query Syntax : INSTrument : PHASe : SLAVE2?  
 Parameters : <NR1>, valid range: 0 ~ 359.9  
 Return Parameters : <NR1>

### 8.6.2.3 FETCH & MEASURE Sub-system

#### FETCh | MEASure

[ : SCALAr]	
: CURRent	
: AC?	Query the rms current
: DC?	Query the DC current level
: AMPLitude : MAXimum?	Query the peak current
: CRESTfactor?	Query the current crest factor
: INRush?	Query the inrush current
: FREQuency?	Query the frequency
: POWer	
: AC	
[: REAL]?	Query the true power
: APParent?	Query the apparent power
: REACTive?	Query the reactive power
: PFACTor?	Query the power factor
: TOTAl?	Query the total power
: VOLTage	
: ACDC?	Query the rms voltage
: DC?	Query the DC voltage

This command lets the user get measurement data from the AC Source. Two measurement commands are available: MEASure and FETCh. MEASure triggers the acquisition of new data before returning data. FETCh returns the previously acquired data from measurement buffer.

**FETCh [ : SCALAr] : CURRent : AC?****MEASure [ : SCALAr] : CURRent : AC?**

Description : These queries return the rms current which is being output at the output terminal.

Query Syntax : FETCh : CURRent : AC?, MEASure : CURRent : AC?

Return Parameters : <NR2>

**FETCh [ : SCALAr] : CURRent : DC?****MEASure [ : SCALAr] : CURRent : DC?**

Description : These queries return the DC current which is being output at the output terminal.

Query Syntax : FETCh : CURRent : DC?, MEASure : CURRent : DC?

Return Parameters : <NR2>

**FETCh [ : SCALAr] : CURRent : AMPLitude : MAXimum?****MEASure [ : SCALAr] : CURRent : AMPLitude : MAXimum?**

Description : These queries return the absolute value of peak current.

Query Syntax : FETCh : CURRent : AMPLitude : MAXimum?,  
MEASure : CURRent : AMPLitude : MAXimum?

Return Parameters : <NR2>

**FETCh [ : SCALAr] : CURRent : CRESfactor?****MEASure [ : SCALAr] : CURRent : CRESfactor?**

Description : These queries return the output current crest factor. It is the ratio of peak output current to rms output current.

Query Syntax : FETCh : CURRent : CRESfactor?  
MEASure : CURRent : CRESfactor?

Return Parameters : <NR2>

**FETCh [ : SCALAr] : CURRent : INRush?****MEASure [ : SCALAr] : CURRent : INRush?**

Description : These queries return the inrush current which is being output at the output terminal.

Query Syntax : FETCh:CURRent: INRush?, MEASure: CURRent : INRush?

Return Parameters : <NR2>

**FETCh [ : SCALAr] : FREQuency?****MEASure [ : SCALAr] : FREQuency?**

Description : These queries return the output frequency in Hertz.

Query Syntax : FETCh : FREQuency?  
MEASure : FREQuency?

Return Parameters : <NR2>

**FETCh [ : SCALAr] : POWer : AC [ : REAL] ?****MEASure [ : SCALAr] : POWer : AC [ : REAL] ?**

Description : These queries return the true power which is being output at output terminals in watts.

Query Syntax : FETCh : POWer : AC?  
MEASure : POWer : AC?

Return Parameters : <NR2>

**FETCh [ : SCALAr] : POWer : AC : APParent?**

**MEASure [ : SCALAr] : POWer : AC : APParent?**

Description : These queries return the apparent power which is being output at output terminals in volt-amperes.

Query Syntax : FETCh : POWer : AC : APParent?  
MEASure : POWer : AC : APParent?

Return Parameters : <NR2>

**FETCh [ : SCALAr] : POWer : AC : REACTive?**

**MEASure [ : SCALAr] : POWer : AC : REACTive?**

Description : These queries return the reactive power which is being output at output terminals in volt-amperes. Reactive power is computed

$$\text{as: } VAR = \sqrt{APPARENTPOWER^2 - REALPOWER^2}$$

Query Syntax : FETCh : POWer : AC : REACTive?  
MEASure : POWer : AC : REACTive?

Return Parameters : <NR2>

**FETCh [ : SCALAr] : POWer : AC : PFACTor?**

**MEASure [ : SCALAr] : POWer : AC : PFACTor?**

Description : These queries return the power factor which is being output at output terminals. Power factor is computed as:

$$PF = TRUE\ POWER / APPARENT\ POWER$$

Query Syntax : FETCh : POWer : AC : PFACTor?  
MEASure : POWer : AC : PFACTor?

Return Parameters : <NR2>

**FETCh [ : SCALAr] : POWer : AC : TOTAl ?**

**MEASure [ : SCALAr] : POWer : AC : TOTAl ?**

Description : These queries return the total true power which is being output at 3-phase of output terminals in watts.

Query Syntax : FETCh : POWer : AC : TOTAl?  
MEASure : POWer : AC : TOTAl?

Return Parameters : <NR2>

**FETCh [ : SCALAr] : VOLTage : ACDC?**

**MEASure [ : SCALAr] : VOLTage : ACDC?**

Description : These queries return the rms voltage which is being output at the output terminals.

Query Syntax : FETCh [ : SCALAr] : VOLTage : ACDC?  
MEASure [ : SCALAr] : VOLTage : ACDC?

Return Parameters : <NR2>

**FETCh [ : SCALAr] : VOLTage : DC?**

**MEASure [ : SCALAr] : VOLTage : DC?**

Description : These queries return the DC composition of output voltage which is being output at the output terminals.

Query Syntax : FETCh [ : SCALAr ] : VOLTage : DC?  
 MEASure [ : SCALAr ] : VOLTage : DC?  
 Return Parameters : <NR2>

#### 8.6.2.4 OUTPUT Sub-system

##### OUTPut

[ : STATe]  
 : RELay  
 : SLEW  
 : VOLTage  
 : AC  
 : DC  
 : MODE  
 : PROTection  
 : CLear

##### OUTPut [ : STATe]

Description : This command enables or disables the output of the AC Source.  
 Disable output is to set an output voltage amplitude at 0 Volt.  
 Query Syntax : OUTPut [ : STATe] ?  
 Parameters : OFF | ON  
 Return Parameters : OFF | ON

##### OUTPut : RELay

Description : This command sets output relay on or off.  
 Query Syntax : OUTPut : RELay ?  
 Parameters : OFF | ON, ON sets the output relay of the AC Source on  
 (closed). OFF sets the output relay of the AC Source off (open).  
 Return Parameters : OFF | ON

##### OUTPut : SLEW : VOLTage : AC

Description : This command sets the slew rate of the AC output voltage.  
 Query Syntax : OUTPut : SLEW : VOLTage : AC ?  
 Parameters : <NR2>, valid range: 0.000V/ms ~ 1200.000V/ms  
 Return Parameters : <NR2>

##### OUTPut : SLEW : VOLTage : DC

Description : This command sets the slew rate of the DC composition  
 voltage.  
 Query Syntax : OUTPut : SLEW : VOLTage : DC ?  
 Parameters : <NR2>, valid range: 0.000V/ms ~ 1000.000V/ms  
 Return Parameters : <NR2>

##### OUTPut : MODE

Description : This command sets the operation mode. "FIXED" MODE is  
 normal used.

Query Syntax : OUTPut : MODE?  
Parameters : FIXED | LIST | PULSE | STEP | INTERHAR  
Return Parameters : FIXED | LIST | PULSE | STEP | INTERHAR

**OUTPut : PROTection : CLear**

Description : This command clears the latch that disables the output when an overcurrent (OC), overtemperature (OT), overpower (OP) or remote inhibit (RI) is detected. All conditions, which have generated the fault, must be removed before the latch is cleared.

Query Syntax : None  
Parameters : None  
Return Parameters : None

**8.6.2.5 SOURCE Sub-system**

**[SOURce :]**

CURRent  
: LIMit  
: DELay  
: INRush  
: STARt  
: INTerval  
FREQency  
[: {CW | IMMEDIATE}]  
VOLTage  
[: LEVel][: IMMEDIATE][:AMPLitude]  
: AC  
: DC  
: LIMit  
: AC  
: DC  
: PLUS  
: MINus  
: RANGe

**FUNCtion**

: SHAPe  
: SHAPe  
: A  
: A  
: MODE  
: THD  
: AMP  
: B  
: B  
: MODE  
: THD  
: AMP

**[SOURCE :] CURRENT : LIMIt**

Description : This command sets the rms current limit of the AC Source for software protection.

Query Syntax : [SOURCE :] CURRENT : LIMIt?

Parameters : <NR2>, valid range: 0.00 ~ maximum current spec. of the specific model. (unit: A)

Return Parameters : <NR2>

**[SOURCE :] CURRENT : DELay**

Description : This command sets the delay time for triggering over current protection.

Query Syntax : [SOURCE :] CURRENT : DELay?

Parameters : <NR2>, valid range: 0.0 ~ 5.0 (unit: 0.5 second)

Return Parameters : <NR2>

**[SOURCE :] CURRENT : INRUsh : STARt**

Description : This command sets the start time of the inrush current measurement.

Query Syntax : [SOURCE :] CURRENT : INRUsh : STARt?

Parameters : <NR2>, valid range: 0.0 ~ 999.9 (unit: ms)

Return Parameters : <NR2>

**[SOURCE :] CURRENT : INRUsh : INTerval**

Description : This command sets the measuring interval of the inrush current measurement.

Query Syntax : [SOURCE :] CURRENT : INRUsh : INTerval?

Parameters : <NR2>, valid range: 0.0 ~ 999.9 (unit: ms)

Return Parameters : <NR2>

**[SOURCE :] FREQuency [: {CW | IMMEDIATE}]**

Description : The command sets the frequency of the output waveform of the AC Source in Hz.

Query Syntax : [SOURCE :] FREQuency [: {CW | IMMEDIATE}]?

Parameters : <NR2>, valid range: 15.00 ~ 1200.00 (unit: Hz)

Return Parameters : <NR2>

**[SOURCE :] FUNCtion : SHAPe**

Description : This command specifies the waveform buffer. There are two buffers for the output of the AC Source, so the user must specify the contents of waveform buffer A or B of the AC Source.

Query Syntax : [SOURCE :] FUNCtion : SHAPe?

Parameters : A | B

Return Parameters : A | B

**[SOURCE :] FUNCtion : SHAPe : A**

Description : This command specifies the waveform shape of waveform buffer A.

Query Syntax : [SOURCE :] FUNCtion : SHAPe : A?

Parameters : SINE | SQUA | CSIN | DST<01..30> | USR<01..06>  
Return Parameters : SINE | SQUA | CSIN | DST<01..30> | USR<01..06>

**[SOURCE :] FUNCTION : SHAPE : A : MODE**

Description : This command selects the mode of the value for the clipped sine in waveform buffer A.  
Query Syntax : [SOURCE :] FUNCTION : SHAPE : A : MODE?  
Parameters : AMP | THD  
Return Parameters : AMP | THD

**[SOURCE :] FUNCTION : SHAPE : A : THD**

Description : This command sets the percentage of THD at which the clipped sine clips in waveform buffer A.  
Query Syntax : [SOURCE :] FUNCTION : SHAPE : A : THD?  
Parameters : <NR2>, valid range: 0.0% ~ 43%  
Return Parameters : <NR2>

**[SOURCE :] FUNCTION : SHAPE : A : AMP**

Description : This command sets the percentage of peak at which the clipped sine clips in waveform buffer A.  
Query Syntax : [SOURCE :] FUNCTION : SHAPE : A : AMP?  
Parameters : <NR2>, valid range: 0.0% ~ 100%  
Return Parameters : <NR2>

**[SOURCE :] FUNCTION : SHAPE : B**

Description : This command specifies the waveform shape of waveform buffer B.  
Query Syntax : [SOURCE :] FUNCTION : SHAPE : B?  
Parameters : SINE | SQUA | CSIN | DST<01..30> | USR<01..06>  
Return Parameters : SINE | SQUA | CSIN | DST<01..30> | USR<01..06>

**[SOURCE :] FUNCTION : SHAPE : B : MODE**

Description : This command selects the mode of the value for the clipped sine in waveform buffer B.  
Query Syntax : [SOURCE :] FUNCTION : SHAPE : B : MODE?  
Parameters : AMP | THD  
Return Parameters : AMP | THD

**[SOURCE :] FUNCTION : SHAPE : B : THD**

Description : This command sets the percentage of THD at which the clipped sine clips in waveform buffer B.  
Query Syntax : [SOURCE :] FUNCTION : SHAPE : B : THD?  
Parameters : <NR2>, valid range: 0.0% ~ 43%  
Return Parameters : <NR2>

**[SOURCE :] FUNCTION : SHAPE : B : AMP**

Description : This command sets the percentage of peak at which the clipped sine clips in waveform buffer B.  
Query Syntax : [SOURCE :] FUNCTION : SHAPE : B : AMP?



Parameters : <NR2>, valid range: 0.0% ~ 100%  
 Return Parameters : <NR2>

**[SOURCE :] VOLTage [: LEVel][: IMMEDIATE][: AMPLitude] : AC**

Description : This command sets the AC composition of output voltage in Volts.  
 Query Syntax : [SOURCE :] VOLTage [: LEVel][: IMMEDIATE][: AMPLitude] : AC?  
 Parameters : <NR2>, valid range: 0.0 ~ 150.0 (in low range), 0.0 ~ 300.0 (in high range)  
 Return Parameters : <NR2>

**[SOURCE :] VOLTage [: LEVel][: IMMEDIATE][: AMPLitude] : DC**

Description : This command sets the DC composition of output voltage in Volts.  
 Query Syntax : [SOURCE :] VOLTage [: LEVel][: IMMEDIATE][: AMPLitude] : DC?  
 Parameters : <NR2>, valid range: -212.1 ~ 212.1 (in low range), -424.2 ~ 424.2 (in high range)  
 Return Parameters : <NR2>

**[SOURCE :] VOLTage : LIMit : AC**

Description : This command sets the setting of Vac LIMIT which will restrict the value of Vac.  
 Query Syntax : [SOURCE :] VOLTage : LIMit : AC?  
 Parameters : <NR2>, valid range: 0.0 ~ 300.0 (unit: V)  
 Return Parameters : <NR2>

**[SOURCE :] VOLTage : LIMit : DC : PLUS**

Description : This command sets the setting of Vdc LIMIT(+) which will restrict the value of Vdc.  
 Query Syntax : [SOURCE :] VOLTage : LIMit : DC : PLUS?  
 Parameters : <NR2>, valid range: 0.0 ~ 424.2 (unit: V)  
 Return Parameters : <NR2>

**[SOURCE :] VOLTage : LIMit : DC : MINus**

Description : This command sets the setting of Vdc LIMIT(-) which will restrict the value of Vdc.  
 Query Syntax : [SOURCE :] VOLTage : LIMit : DC : MINus?  
 Parameters : <NR2>, valid range: 0.0 ~ -424.2 (unit: V)  
 Return Parameters : <NR2>

**[SOURCE :] VOLTage : RANGE**

Description : This command sets output voltage range with two options of LOW(150 V), HIGH(300 V).  
 Query Syntax : [SOURCE :] VOLTage : RANGE?  
 Parameters : LOW | HIGH  
 Return Parameters : LOW | HIGH

### 8.6.2.6 CONFIGURE Sub-system

**[SOURCE :]**  
CONFigure  
: INHhibit

#### **[SOURCE :] CONFigure : INHhibit?**

Description : This command sets REMOTE INHIBIT state. There are three states for the feature of remote inhibit: OFF, LIVE, and TRIG.  
Query Syntax : [SOURCE :] CONFigure : INHhibit?  
Parameters : OFF | LIVE | TRIG  
Return Parameters : OFF | LIVE | TRIG

### 8.6.2.7 PHASE Sub-system

**[SOURCE :]**  
PHASe  
: ON  
: OFF

#### **[SOURCE :] PHASe : ON**

Description : This command sets the transition angle of the waveform when it out. Default DEGREE ON is 0 degree.  
Query Syntax : [SOURCE :] PHASe : ON?  
Parameters : <NR2>, valid range: 0.0 ~ 359.9  
Return Parameters : <NR2>

#### **[SOURCE :] PHASe : OFF**

Description : This command sets the transition angle of the waveform when it quit.  
Query Syntax : [SOURCE :] PHASe : OFF?  
Parameters : <NR2>, valid range: 0.0 ~ 360.0, 360.0: mean is IMMED.  
Return Parameters : <NR2>

### 8.6.2.8 TRACE Sub-system

**TRACe**  
: RMS

#### **TRACe**

Description : This command sets waveform data of user-defined. It needs 1024 data points to construct a period of waveform. Users have to normalize the data as the maximum point equal to 32767 or the minimum point equal to -32767.  
Syntax : **TRACe** <waveform\_name>, <amplitude> {,<amplitude>}

Parameters : <waveform\_name>:US<n>, n=1~6, <amplitude>:<NR1>, valid range : -32767 ~ 32767.  
 Example : **TRACe** US1 100 200 ...32767... 500 800 <= 1024 points  
 This command needs about 5 sec to execute.

**TRACe : RMS**

Description : This command sets the rms value of user's waveform.  
 Users need to calculate the root mean square value of 1024 data points.  
 Syntax : **TRACe : RMS** <waveform\_name>, <rms>  
 Parameters : <waveform\_name>:US<n>, n=1~6, <rms>:<NR1>, valid range: 0 ~ 32767.  
 Example : **TRACe : RMS** US1 27000

**8.6.2.9 LIST Sub-system****[SOURce:]****LIST**

: COUPle  
 : POINts?  
 : COUNT  
 : DWELl  
 : SHAPe  
 : BASE  
 : VOLTage  
 : AC  
 : START  
 : END  
 : DC  
 : START  
 : END  
 : FREQuency  
 : START  
 : END  
 : DEGRee

**OUTPut**

: MODE

**TRIG**

**TRIG : STATE?**

**[SOURce:]LIST : COUPle**

Description : This command sets the mode of list function.  
 Query Syntax : [SOURce:] LIST : COUPle?

Parameters : ALL | NONE  
Return Parameters : ALL | NONE

**[SOURce:] LIST : POINTs?**

Description : This command returns the number of sequences of the list mode.  
Query Syntax : [SOURce:] LIST : POINTs?  
Parameters : None  
Return Parameters : <NR1>, valid range: 0 ~ 100

**[SOURce :] LIST : COUNT**

Description : This command sets the number of times that the list is executed before it is completed.  
Query Syntax : [SOURce :] LIST : COUNT?  
Parameters : <NR1>, valid range: 0 ~ 65535  
Return Parameters : <NR1>

**[SOURce :] LIST : DWELI**

Description : This command sets the sequence of dwell time list points.  
Query Syntax : [SOURce:] LIST : DWELI?  
Parameters : <NR2>, ..., <NR2> valid range: 0 ~ 99999999.9 (unit: ms)  
Return Parameters : <NR2>, ..., <NR2>

**[SOURce :] LIST : SHAPe**

Description : This command sets the sequence of waveform buffer list points .  
Query Syntax : [SOURce:] LIST : SHAPe?  
Parameters : A|B, ..., A|B  
Return Parameters : A|B, ..., A|B

**[SOURce :] LIST : BASE**

Description : This command sets time base of list.  
Query Syntax : [SOURce:] LIST : BASE?  
Parameters : TIME | CYCLE  
Return Parameters : TIME | CYCLE

**[SOURce :] LIST : VOLTage : AC : START**

Description : This command sets the sequence of AC start voltage list points.  
Query Syntax : [SOURce:] LIST : VOLTage : AC : START?  
Parameters : <NR2>, ..., <NR2> valid range: 0.0 ~ 150.0 (in low range),0.0 ~ 300.0 (in high range)  
Return Parameters : <NR1>, ..., <NR2>

**[SOURce :] LIST : VOLTage : AC : END**

Description : This command sets the sequence of AC end voltage list points.  
Query Syntax : [SOURce:] LIST : VOLTage : AC : END?  
Parameters : <NR2>, ..., <NR2> valid range: 0.0 ~ 150.0 (in low range),0.0

Return Parameters : ~ 300.0 (in high range)  
: <NR2>, ..., <NR2>

**[SOURCE :] LIST : VOLTage : DC : START**

Description : This command sets the sequence of DC start voltage list points.  
Query Syntax : [SOURCE:] LIST : VOLTage : DC : START?  
Parameters : <NR2>, ..., <NR2> valid range: -212.1 ~ 212.1 (in low range), -424.2 ~ 414.2 (in high range)  
Return Parameters : <NR1>

**[SOURCE :] LIST : VOLTage : DC : END**

Description : This command sets the sequence of DC end voltage list points.  
Query Syntax : [SOURCE:] LIST : VOLTage : DC : START?  
Parameters : <NR2>, ..., <NR2> valid range: -212.2 ~ 212.1 (in low range), -424.2 ~ 414.2 (in high range)  
Return Parameters : <NR2>, ..., <NR2>

**[SOURCE :] LIST : FREQuency : START**

Description : This command sets the sequence of start frequency list points.  
Query Syntax : [SOURCE:] LIST : FREQuency : START?  
Parameters : <NR2>, ..., <NR2> valid range: 15.00 ~ 1000.00 (unit: Hz)  
Return Parameters : <NR2>, ..., <NR2>

**[SOURCE :] LIST : FREQuency : END**

Description : This command sets the sequence of end frequency list points.  
Query Syntax : [SOURCE:] LIST : FREQuency : END?  
Parameters : <NR2>, ..., <NR2> valid range: 15.00 ~ 1000.00 (unit: Hz)  
Return Parameters : <NR2>, ..., <NR2>

**[SOURCE :] LIST : DEGRee**

Description : This command sets the sequence of phase angle list points.  
Query Syntax : [SOURCE:] LIST : DEGRee?  
Parameters : <NR2>, ..., <NR2> valid range: 0.0 ~ 359.9  
Return Parameters : <NR2>, ..., <NR2>

**OUTPut : MODE**

Description : This command sets the operation mode.  
Query Syntax : OUTPut : MODE?  
Parameters : FIXED | LIST | PULSE | STEP | SYNTH | INTERHAR  
Return Parameters : FIXED | LIST | PULSE | STEP | SYNTH | INTERHAR

**TRIG**

Description : This command sets LIST mode in OFF, ON execution state after setting **OUTPut : MODE LIST**. If users want to change the parameters, it's necessary to set **TRIG OFF**

then **OUTPut : MODE FIXED**. Then, set **OUTPut : MODE LIST** again to get ready to set **TRIG ON**.

Query Syntax	: TRIG : STATE?
Parameters	: OFF   ON
Return Parameters	: OFF   RUNNING

### 8.6.2.10 PULSE Sub-system

**[SOURce :]**  
**PULSe**  
: VOLTage  
: AC  
: DC  
: FREQuency  
: SHAPe  
: SPHase  
: COUNT  
: DCYCLe  
: PERiod

**OUTPut**  
: MODE

**TRIG**  
**TRIG : STATE?**

#### **[SOURce :] PULSe : VOLTage : AC**

Description	: This command sets AC voltage in the duty cycle of PULSE mode.
Query Syntax	: [SOURce :] PULSe : VOLTage : AC?
Parameters	: <NR2>, valid range: 0.0 ~ 150.0 (in low range), 0.0 ~ 300.0 (in high range)
Return Parameters	: <NR2>

#### **[SOURce :] PULSe : VOLTage : DC**

Description	: This command sets the DC voltage in the duty cycle of PULSE mode.
Query Syntax	: [SOURce :] PULSe : VOLTage : DC?
Parameters	: <NR2>, valid range: -212.1 ~ 212.1 (in low range), -424.2 ~ 424.2 (in high range)
Return Parameters	: <NR2>

#### **[SOURce :] PULSe : FREQuency**

Description	: This command sets the frequency during the duty cycle of PULSE mode.
Query Syntax	: [SOURce :] PULSe : FREQuency?

Parameters : <NR2>, valid range: 15.00 ~ 1000.00 (unit: Hz)  
 Return Parameters : <NR2>

**[SOURce :] PULSe : SHAPe**

Description : This command selects the waveform buffer for PULSE mode.  
 Query Syntax : [SOURce :] PULSE : SHAPe?  
 Parameters : A | B  
 Return Parameters : A | B

**[SOURce :] PULSe : SPHase**

Description : This command sets the start phase angle of duty cycle of PULSE mode.  
 Query Syntax : [SOURce :] PULSE : SPHase?  
 Parameters : <NR2>, valid range: 0.0 ~ 359.9  
 Return Parameters : <NR2>

**[SOURce :] PULSe : COUNT**

Description : This command sets the number of times that the pulse is executed before it is completed.  
 Query Syntax : [SOURce :] PULSE : COUNT?  
 Parameters : <NR2>, valid range: 0 ~ 65535  
 Return Parameters : <NR2>

**[SOURce :] PULSe : DCYClE**

Description : This command sets the duty cycle of PULSE mode.  
 Query Syntax : [SOURce :] PULSE : DCYClE?  
 Parameters : <NR2>, valid range: 0 % ~ 100 %  
 Return Parameters : <NR2>

**[SOURce :] PULSe : PERIod**

Description : This command sets the period of the PULSE mode.  
 Query Syntax : [SOURce :] PULSE : PERIod?  
 Parameters : <NR2>, valid range: 0 ~ 99999999.9 (unit: ms)  
 Return Parameters : <NR2>

**OUTPut : MODE**

Description : This command sets the operation mode  
 Query Syntax : OUTPut : MODE?  
 Parameters : FIXED | LIST | PULSE | STEP | SYNTH | INTERHAR  
 Return Parameters : FIXED | LIST | PULSE | STEP | SYNTH | INTERHAR

**TRIG**

Description : This command sets PULSE mode in OFF execution state after setting **OUTPut : MODE PULSE**. If users want to change the parameters, it's necessary to set **TRIG OFF** then **OUTPut : MODE FIXED**. Then, set **OUTPut : MODE PULSE** again to get ready to set **TRIG ON**.  
 Query Syntax : TRIG : STATE?

Parameters : OFF | ON  
Return Parameters : OFF | RUNNING

### 8.6.2.11 STEP Sub-system

#### [SOURCE :]

##### STEP

: VOLTage  
: AC  
: DC  
: FREQuency  
: SHAPe  
: SPHase  
: DVOLTage  
: AC  
: DC  
: DFREquency  
: DWELl  
: COUNT

#### OUTPut

: MODE

#### TRIG

##### TRIG : STATE?

#### [SOURCE :] STEP : VOLTage : AC

Description : This command sets the initial AC voltage of STEP mode.  
Query Syntax : [SOURCE :] STEP : VOLTage : AC?  
Parameters : <NR2>, valid range: 0.0 ~ 150.0 (in low range), 0.0 ~ 300.0  
(in high range)  
Return Parameters : <NR2>

#### [SOURCE :] STEP : VOLTage : DC

Description : This command sets the initial DC voltage of STEP mode.  
Query Syntax : [SOURCE :] STEP : VOLTage : DC?  
Parameters : <NR2>, valid range: -212.1 ~ 212.1 (in low range), -424.2 ~  
414.2 (in high range)  
Return Parameters : <NR2>

#### [SOURCE :] STEP : FREQuency

Description : This command sets the initial frequency of STEP mode.  
Query Syntax : [SOURCE :] STEP : FREQuency?  
Parameters : <NR2>, valid range: 15.00 ~ 1000.00 (unit: Hz)  
Return Parameters : <NR2>



**[SOURce :] STEP : SHAPe**

Description : This command selects the waveform buffer for STEP mode.  
 Query Syntax : [SOURce :] STEP : SHAPe?  
 Parameters : A | B  
 Return Parameters : A | B

**[SOURce :] STEP : SPHase**

Description : This command sets the start phase angle of STEP mode.  
 Query Syntax : [SOURce :] STEP : SPHase?  
 Parameters : <NR2>, valid range: 0.0 ~ 359.9  
 Return Parameters : <NR2>

**[SOURce :] STEP : DVOLTage : AC**

Description : This command sets the delta AC voltage in each step.  
 Query Syntax : [SOURce :] STEP : DVOLTage : AC?  
 Parameters : <NR2>, valid range: 0.0 ~ 150.0 (in low range), 0.0 ~ 300.0 (in high range)  
 Return Parameters : <NR2>

**[SOURce :] STEP : DVOLTage : DC**

Description : This command sets the delta DC voltage in each step.  
 Query Syntax : [SOURce :] STEP : DVOLTage : DC?  
 Parameters : <NR2>, valid range: -212.2 ~ 212.1 (in low range), -424.2 ~ 424.2 (in high range)  
 Return Parameters : <NR2>

**[SOURce :] STEP : DFRequency**

Description : This command sets the delta frequency in each step.  
 Query Syntax : [SOURce :] STEP : DFRequency?  
 Parameters : <NR2>, valid range: 0.00 ~ 1000.00 (unit: Hz)  
 Return Parameters : <NR2>

**[SOURce :] STEP : DWELI**

Description : This command sets the dwell time in each step.  
 Query Syntax : [SOURce :] STEP : DWELI?  
 Parameters : <NR2>, valid range: 0 ~ 99999999.9 (unit: ms)  
 Return Parameters : <NR2>

**[SOURce :] STEP : COUNT**

Description : This command sets the number of times that the step is executed before it is completed.  
 Query Syntax : [SOURce :] STEP : COUNT?  
 Parameters : <NR2>, valid range: 0 ~ 65535  
 Return Parameters : <NR2>

**OUTPut : MODE**

Description : This command sets the operation mode  
 Query Syntax : OUTPut : MODE?

Parameters : FIXED | LIST | PULSE | STEP | SYNTH | INTERHAR  
 Return Parameters : FIXED | LIST | PULSE | STEP | SYNTH | INTERHAR

### TRIG

Description : This command sets STEP mode in OFF, ON execution state after setting **OUTPut : MODE STEP**. If users want to change the parameters, it's necessary to set **TRIG OFF** then **OUTPut : MODE FIXED**. Then, set **OUTPut : MODE STEP** again to get ready to set **TRIG ON**.

Query Syntax : TRIG : STATE?  
 Parameters : OFF | ON  
 Return Parameters : OFF | RUNNING

### 8.6.2.12 INTERHARMONICS Sub-system

#### [SOURCE :]

**INTerharmonics**  
 : FREQuency  
     : STARt  
     : ENd  
 : LEVEl  
 : DWELl  
 : MODe

#### OUTPut

: MODE

#### TRIG

TRIG : STATE?

#### FETCh | MEASure

: INTerharmonics  
 : FREQuency?                      Query the sweeping frequency

#### [SOURCE :] INTerharmonics : FREQuency : STARt

Description : This command sets the start frequency of the sweep wave of INTERHARMONICS mode.

Query Syntax : [SOURCE :] INTerharmonics : FREQuency : STARt?  
 Parameters : <NR2>, valid range: 0.01 ~ 2400.00 (unit: Hz)  
 Return Parameters : <NR2>

#### [SOURCE :] INTerharmonics : FREQuency : ENd

Description : This command sets the end frequency of the sweep wave of INTERHARMONICS mode.

Query Syntax : [SOURCE :] INTerharmonics : FREQuency : ENd?  
 Parameters : <NR2>, valid range: 0.01 ~ 2400.00 (unit: Hz)

Return Parameters : <NR2>

#### **[SOURCE :] INTERharmonics : LEVEL**

Description : This command sets the r.m.s. magnitude of the sweep wave in percentage of fundamental.

Query Syntax : [SOURCE :] INTERharmonics : LEVEL?

Parameters : <NR2>, valid range: 0% ~ 30% at 0.01 Hz ~ 500 Hz  
0% ~ 20% at 500.01 Hz ~ 1000 Hz  
0% ~ 10% at 1000.01 Hz ~ 2400 Hz

Return Parameters : <NR2>

#### **[SOURCE :] INTERharmonics : DWELL**

Description : This command sets the dwell time of sweep wave.

Query Syntax : [SOURCE :] INTERharmonics : DWELL?

Parameters : <NR2>, valid range: 0.01 ~ 9999.99 (unit: sec)

Return Parameters : <NR2>

#### **[SOURCE :] INTERharmonics : MODE**

Description : This command sets the mode of interharmonic function.

Query Syntax : [SOURCE :] INTERharmonics : MODE?

Parameters : ALL | #1 | #2 | #3

Return Parameters : ALL | #1 | #2 | #3

#### **OUTPut : MODE**

Description : This command sets the operation mode

Query Syntax : OUTPut : MODE?

Parameters : FIXED | LIST | PULSE | STEP | SYNTH | INTERHAR

Return Parameters : FIXED | LIST | PULSE | STEP | SYNTH | INTERHAR

#### **TRIG**

Description : This command sets INTERHARMONICS mode in OFF, ON, PAUSE or CONTINUE execution state after setting **OUTPut : MODE INTERHAR**. If users want to change the parameters, it's necessary to set **TRIG OFF** then **OUTPut : MODE FIXED**. Then, set **OUTPut : MODE INTERHAR** again to get ready to set **TRIG ON**.

Query Syntax : TRIG : STATE?

Parameters : OFF | ON | PAUSE | CONTINUE

Return Parameters : OFF | RUNNING | COMPLETE

#### **FETCh [:SCALAr] : INTERharmonics : FREQuency?**

#### **MEASure [:SCALAr] : INTERharmonics : FREQuency?**

Description : These queries return the sweeping frequency superimposed on fundamental voltage.

Query Syntax : FETCh : INTERHARMonics : FREQuency?

MEASure : INTERHARMonics : FREQuency?

Return Parameters : <NR2>

### 8.6.2.13 STATUS Sub-system

#### STATus

: OPERation  
  [: EVENT]?  
  : ENABle  
: QUEStionable  
  : CONDItion  
  : ENABle  
  : NTRansition  
  : PTRansition

#### STATus : OPERation [: EVENT]?

Description : This command queries the Operation Status register.  
Query Syntax : STATus : OPERation [: EVENT]?  
Parameters : None  
Return Parameters : Always zero.

#### STATus : OPERation : ENABle

Description : This command sets the Operation Status Enable register. The register is a mask which enables specific bits from the Operation Status register.  
Query Syntax : STATus : OPERation : ENABle?  
Parameters : <NR1>, valid range: 0 ~ 255  
Return Parameters : Always zero

#### STATus : QUEStionable : CONDItion?

Description : This query returns the value of the Questionable Condition register, which is a read-only register that holds the real-time questionable status of the AC Source.  
Query Syntax : STATus : QUEStionable : CONDItion?  
Parameters : NONE  
Return Parameters : <NR1>, valid range: 0 ~ 511

#### STATus : QUEStionable [: EVENT] ?

Description : This query returns the value of the Questionable Event register. The Event register is a read-only register which holds all events that are passed by the Questionable NTR and/or PTR filter. If QUES bit of the Service Request Enabled register is set, and the Questionable Event register > 0, QUES bit of the Status Byte register is set too.  
Query Syntax : STATus : QUEStionable [: EVENT] ?  
Parameters : NONE  
Return Parameters : <NR1>, valid range: 0 ~ 511

#### STATus : QUEStionable : ENABle

Description : This command sets or reads the value of the Questionable Enable register. The register is a mask which enables specific

bits from the Questionable Event register to set the questionable summary (QUES) bit of the Status Byte register.

Query Syntax : STATus : QUESTionable : ENABle?  
 Parameters : <NR1>, valid range: 0 ~ 65535  
 Return Parameters : <NR1>

**STATus : QUESTionable : NTRansition**

Description : These commands make the values of the Questionable NTR register set or read.

These registers serve as polarity filters between the Questionable Enable and Questionable Event registers, and result in the following actions:

- \* When a bit of the Questionable NTR register is set at 1, a 1-to-0 transition of the corresponding bit in the Questionable Condition register will cause that bit in the Questionable Event register to be set.
- \* When a bit of the Questionable PTR register is set at 1, a 0-to-1 transition of the corresponding bit in the Questionable Condition register will cause that bit in the Questionable Event register to be set.
- \* If the two same bits in both NTR and PTR registers are set at 0, no transition of that bit in the Questionable Condition register can set the corresponding bit in the Questionable Event register.

**Bit Configuration of Questionable Status Register**

Bit Position	15-9	8	7	6	5	4	3	2	1	0
Condition	---	OVP	INP	OCP	FAN	SHT	OTP	OPP	INT-DD	INT-AD

OVP : Output voltage protection

INP : Line input protection.

OCP : Over current protection.

FAN : Fan failure.

SHT : Output short protection.

OTP : Over temperature protection.

OPP : Over power protection.

INT-DD : Inner DD power stage protection

INT-AD : Inner AD power stage protection

Query Syntax : STATus : QUESTionable : NTRansition?  
 Parameters : <NR1>, valid range: 0 ~ 65535  
 Return Parameters : <NR1>

**STATus : QUESTionable : PTRansition**

Description : These commands make the values of the Questionable PTR register set or read. Please refer to the description of the previous command.

Query Syntax : STATus : QUESTionable : PTRansition?

Parameter : <NR1>, valid range: 0 ~ 511  
Return parameters : <NR1>

## 8.7 Command Summary

### *Common Commands*

\* CLS Clear status  
\* ESE<n> Standard event status enable  
\* ESE? Return standard event status enable  
\* IDN? Return the AC Source identification  
\* RCL<n> Recall the AC Source file  
\* RST Reset the AC Source to the initial states  
\* SAV<n> Save the AC Source status  
\* SRE Set request enable register  
\* STB? Return status byte  
\* TST? Return the self-test result of the AC Source

### *Instrument Commands*

#### **SYSTem**

: ERRor?  
: VERSion?  
: LOCal  
: REMote

#### **INSTrument**

: COUPlE  
: NSElect  
: SElect  
: PHASe  
: SLAVE1  
: SLAVE2

#### **FETCh | MEASure**

[ : SCALar]  
: CURRent  
: AC?  
: DC?  
: AMPLitude : MAXimum?  
: CRESfactor?  
: INRush?  
: FREQuency?  
: POWer  
: AC  
[: REAL]?  
: APParent?

: REACtive?  
 : PFACtor?  
 : TOTal?  
 :VOLTage  
 : ACDC?  
 : DC?

**OUTPut**

[: STATe]  
 : RELay  
 : SLEW  
 : VOLTage  
 : AC  
 : DC  
 : MODE  
 : PROTection  
 : CLear

**[SOURce :]**

CURRent  
 : LIMit  
 : DELay  
 : INRush  
 : STARt  
 : INTerval  
 FREQency  
 [: {CW | IMMEDIATE}]  
 VOLTage  
 [: LEVel][: IMMEDIATE][:AMPLitude]  
 : AC  
 : DC  
 : LIMit  
 : AC  
 : DC  
 : PLUS  
 : MINus  
 : RANGe  
 FUNCTion  
 : SHAPe  
 : SHAPe  
 : A  
 : A  
 : MODE  
 : THD  
 : AMP  
 : B  
 : B  
 : MODE  
 : THD

: AMP

LIST

: COUPle  
: POINts?  
: COUNT  
: DWELl  
: SHAPe  
: BASE  
: VOLTage  
  : AC  
    : START  
    : END  
  : DC  
    : START  
    : END  
: FREQuency  
  : START  
  : END  
: DEGRee

PULSe

: VOLTage  
  : AC  
  : DC  
: FREQuency  
: SHAPe  
: SPHase  
: COUNT  
: DCYClE  
: PERiod

STEP

: VOLTage  
  : AC  
  : DC  
: FREQuency  
: SHAPe  
: SPHase  
: DVOLTage  
  : AC  
  : DC  
: DFRequency  
: DWELl  
: COUNT

INTerharmonics

: FREQuency  
  : START



: END  
: LEVEL  
: DWELL  
: MODE

**[SOURCE :]**  
PHASe  
: ON  
: OFF

**[SOURCE :]**  
CONFigure  
: INHibit

**TRACe**  
: RMS

**STATus**  
: OPERation  
[: EVENT]?  
: ENABLE  
: QUEStionable  
: CONDition  
: ENABLE  
: NTRansition  
: PTRansition

**TRIG**  
**TRIG : STATE?**



## Appendix A Pin Assignment of TTL Signal

### 9-Pin D-Type Female Connector:

Pin No.	Signal	Pin No.	Signal
1	GND	6	GND
2	/ Remote-Inhibit	7	GND
3	GND	8	/ FAULT-OUT
4	AC-ON	9	---
5	---		

/ Remote-Inhibit: When voltage level of this pin becomes LOW, it can inhibit the output of AC Source (see 3.6.1).

AC-ON: When AC Source output voltage, this pin will become HIGH, and it becomes LOW when quit output.

/ FAULT-OUT: The voltage level of this pin is HIGH if AC Source is in normal state. It becomes LOW when AC Source is in protection state.



# Appendix B Built-in Waveforms

**DST01**

Harmonic	%
2	2.07
5	9.8
7	15.8
8	2.16

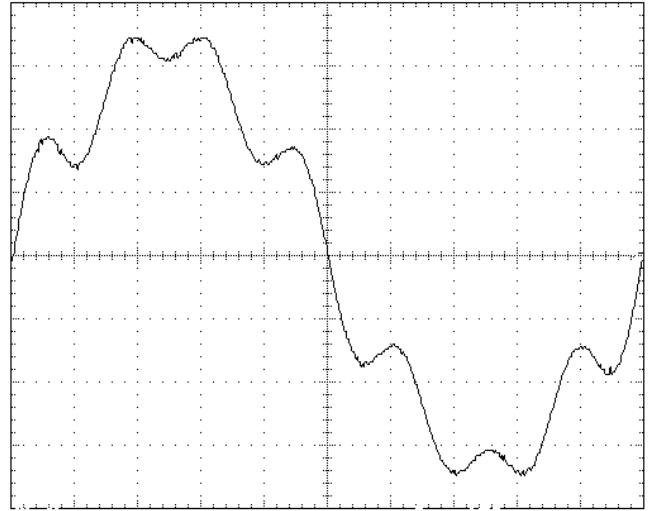

**DST02**

Harmonic	%
3	1.5
7	1.5
19	2

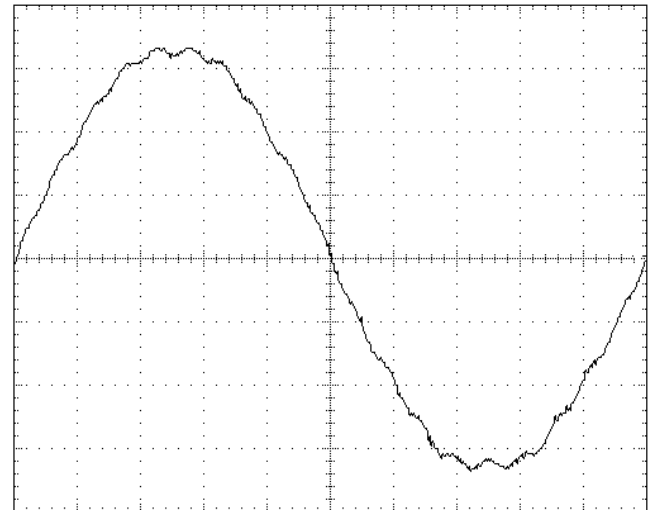

**DST03**

Harmonic	%
3	2
5	1.4
7	2
23	1.4
31	1

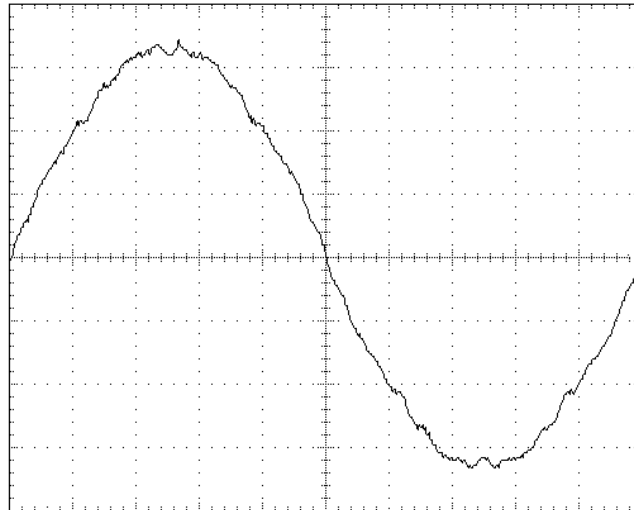

**DST04**

Harmonic	%
3	2.5
5	1.9
7	2.5
23	1.9
25	1.1
31	1.5
33	1.1

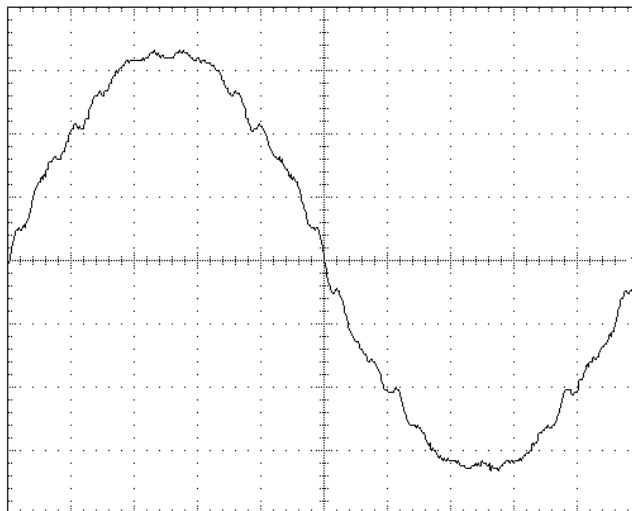

**DST05**

Harmonic	%
3	1.1
5	2.8
7	1.4
9	2.3
11	1.5

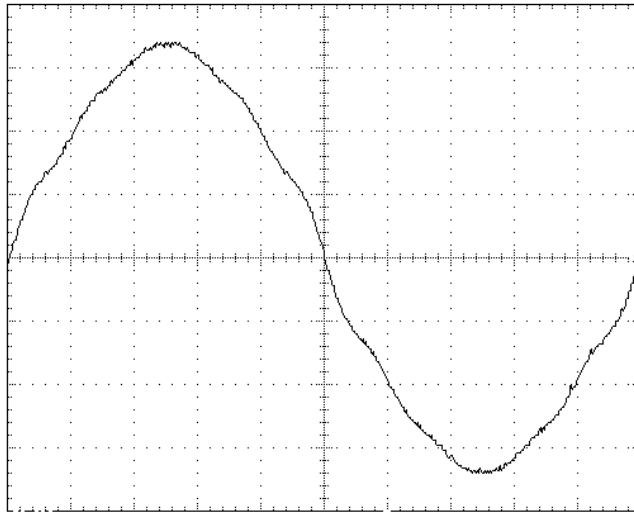

**DST06**

Harmonic	%
3	1.65
5	4.2
7	3.45
15	1.05
19	3

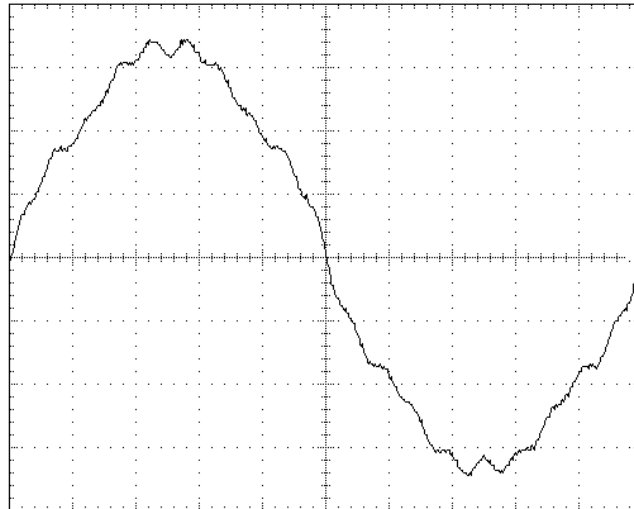

**DST07**

Harmonic	%
3	2.2
5	5.6
7	2.8
9	4.6
11	3
15	1.4
21	1

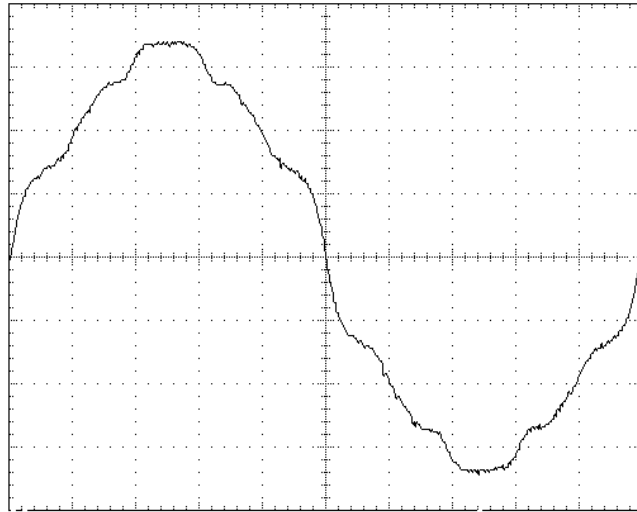

**DST08**

Harmonic	%
3	4.9
5	1.6
7	2.7
11	1.4
15	2
17	1.1

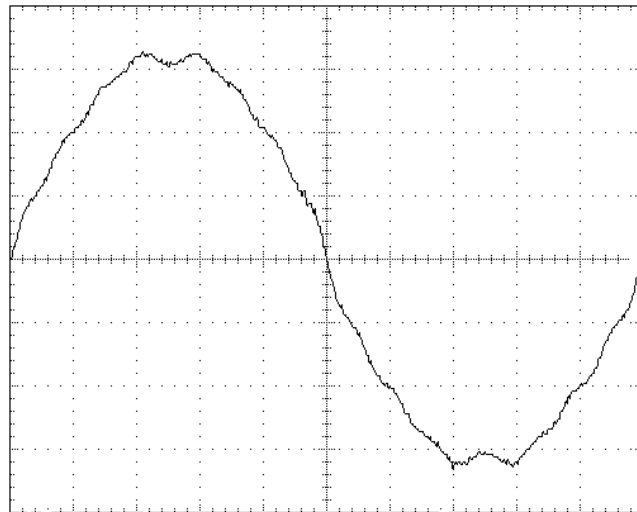



**DST09**

Harmonic	%
3	7.35
5	2.4
7	4.05
11	2.1
13	1.05
15	3
17	1.65
19	1.05
21	1.05
23	1.2
25	1.05

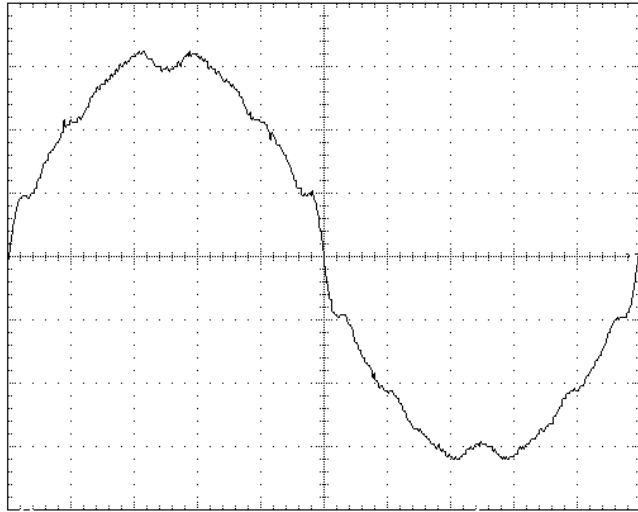

**DST010**

Harmonic	%
3	9.8
5	3.2
7	5.4
9	1.2
11	2.8
13	1.4
15	4
17	2.2
19	1.4
21	1.4
23	1.6
25	1.4

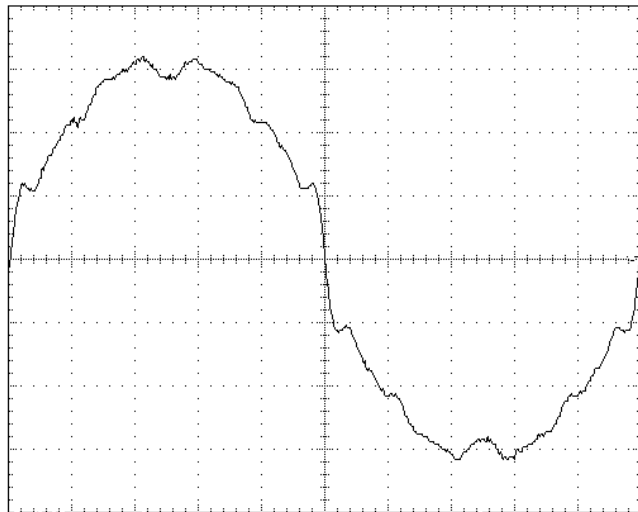

**DST011**

Harmonic	%
3	17.75

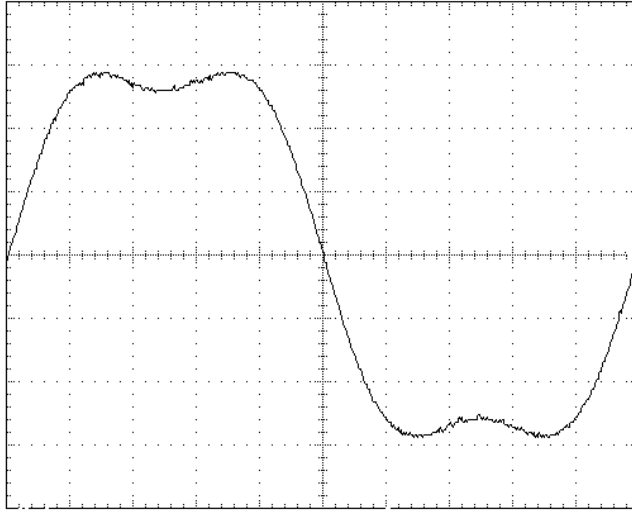

**DST012**

Harmonic	%
3	21.25

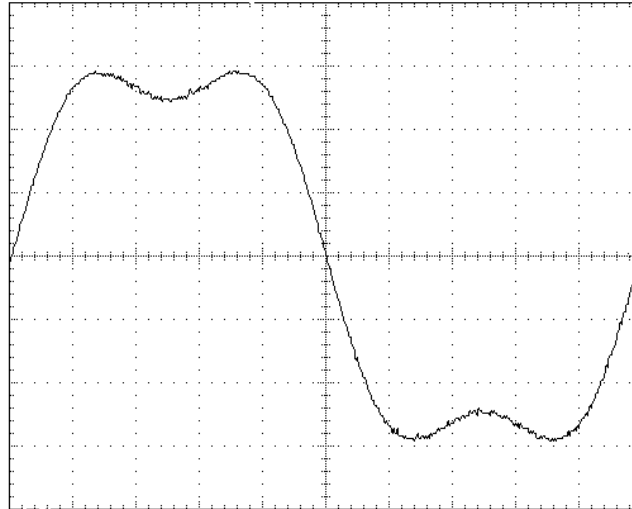

**DST013**

Harmonic	%
3	24.5

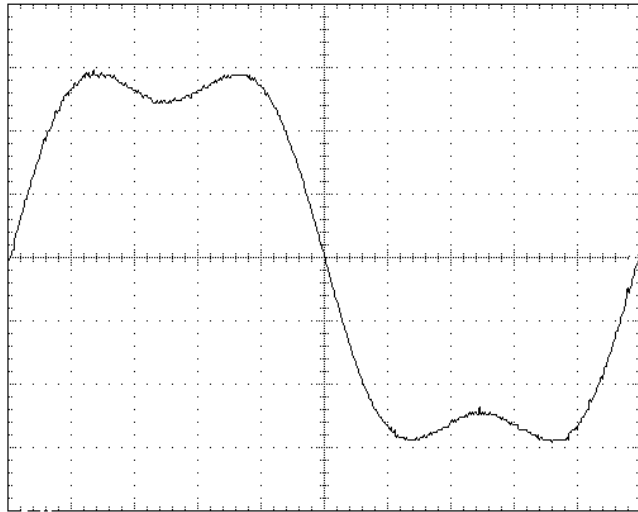

**DST014**

Harmonic	%
2	2.3
5	9.8
7	15.8
8	2.5

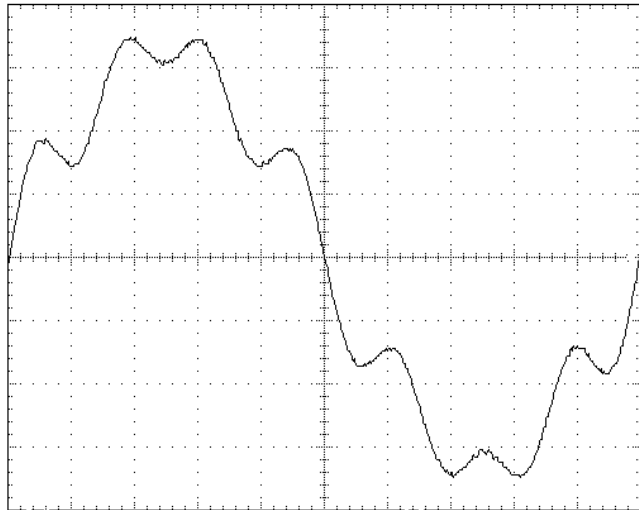

**DST015**

Harmonic	%
2	1.15
5	4.9
7	7.9
8	1.25

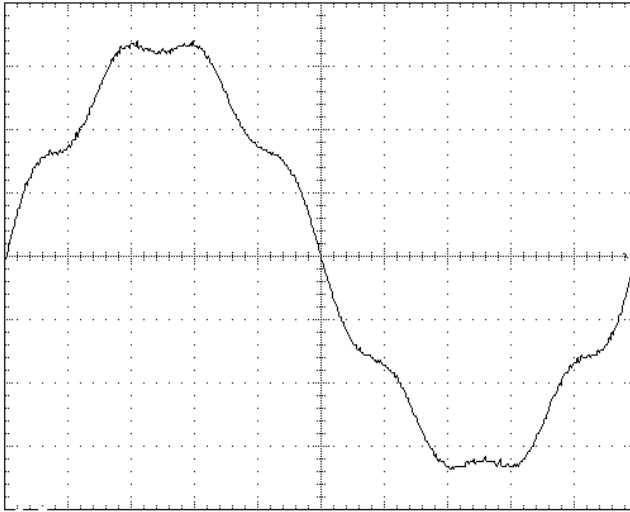

**DST016**

Harmonic	%
5	2.45
7	3.95

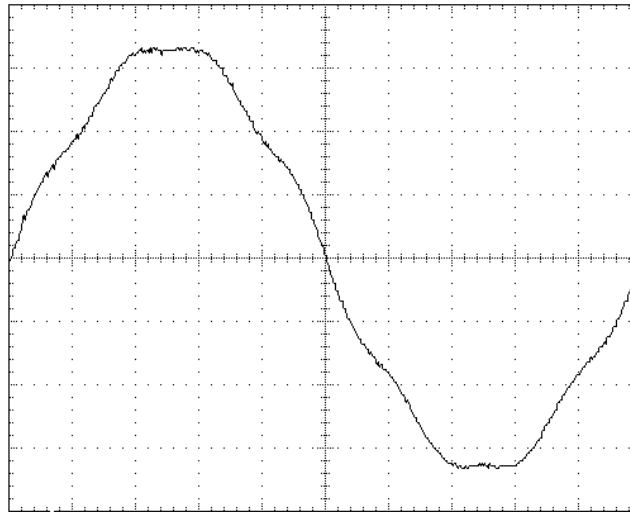

**DST017**

Harmonic	%
3	11
5	4.05
7	2
9	1.3

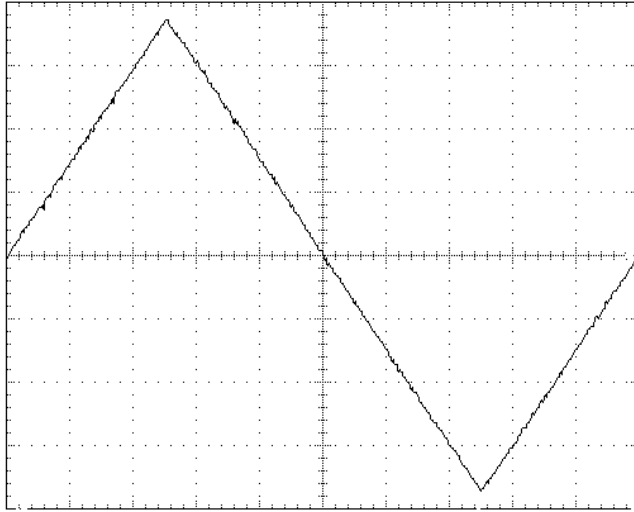

**DST018**

Harmonic	%
3	7.17
5	3.42
9	0.8

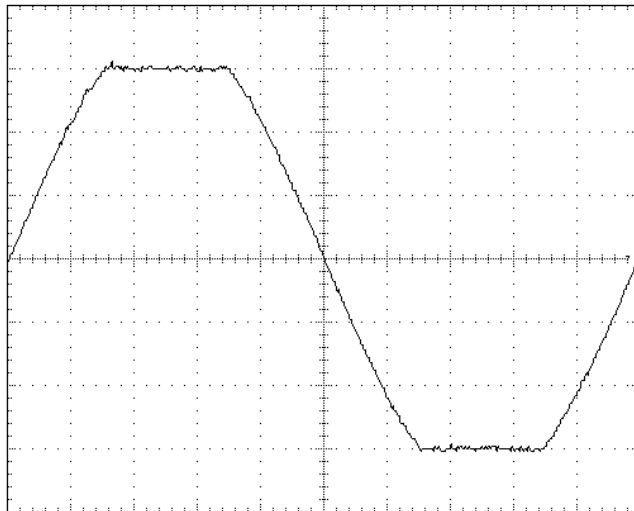

**DST019**

Harmonic	%
3	8.11
5	3.48
9	1

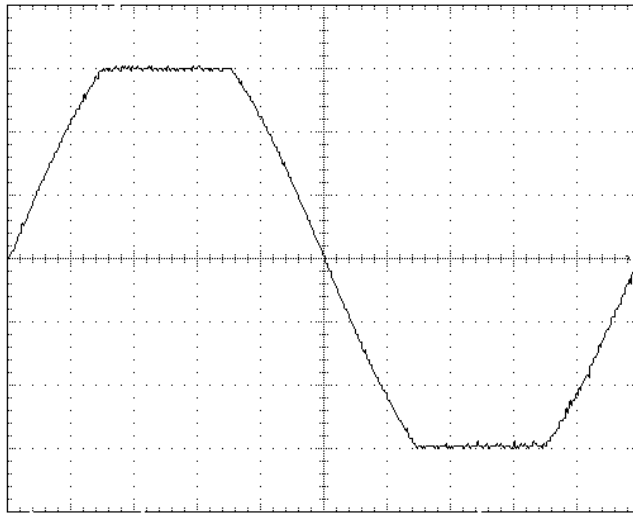

**DST020**

Harmonic	%
3	9.38
5	3.44
9	1.15

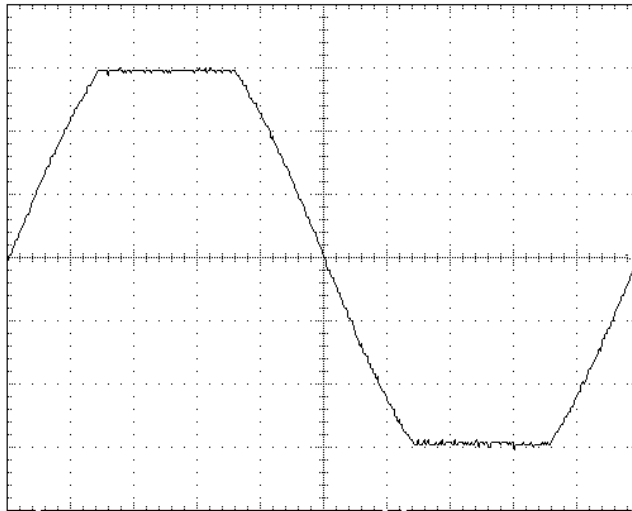

**DST021**

Harmonic	%
3	2
5	1.8
7	1.6
9	1.23
11	0.9

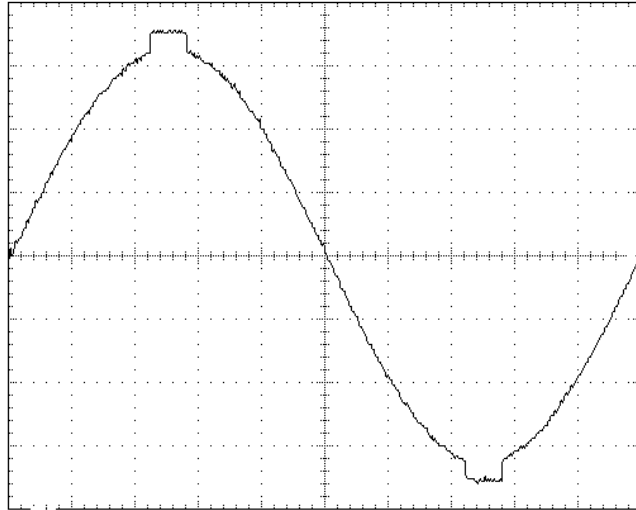

**DST022**

Harmonic	%
3	3
5	2.75
7	2.4
9	2
11	1.4
13	0.8

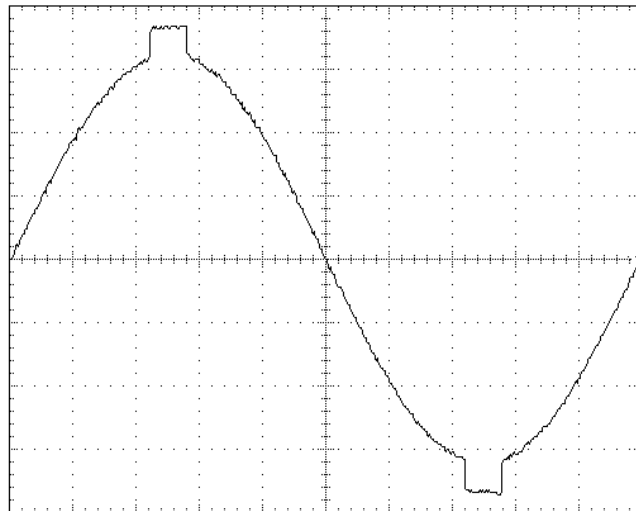

**DST023**

Harmonic	%
3	4.15
5	3.8
7	3.24
9	2.6
11	2
13	1.25

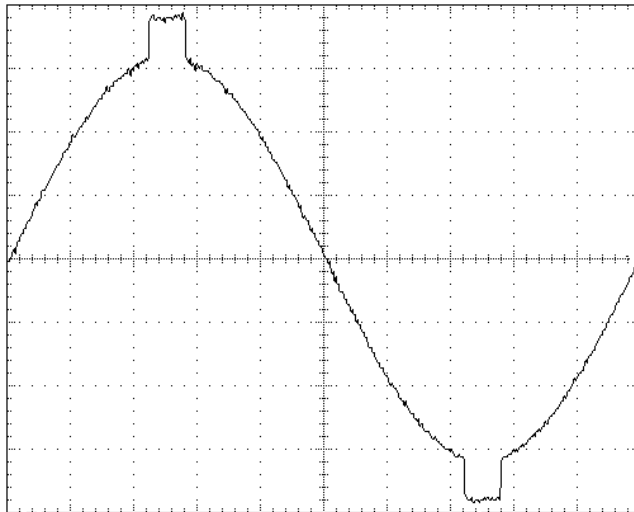

**DST024**

Harmonic	%
3	5.63
5	5.13
7	4.42
9	3.56
11	2.63
13	1.68
15	0.79
21	1.04
23	1.27
25	1.32
27	1.2
29	0.95

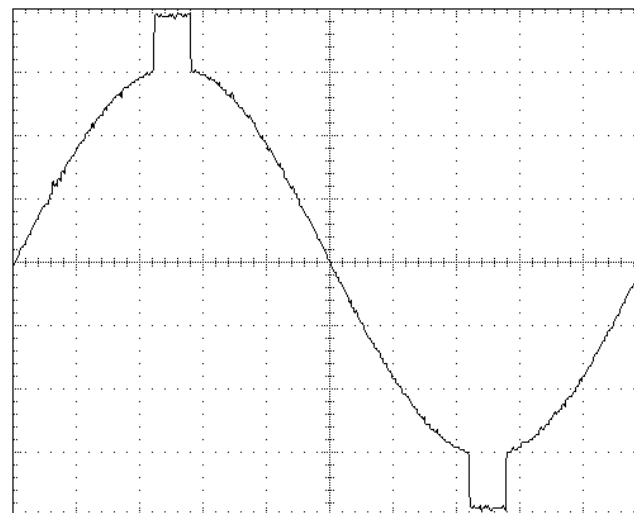



**DST025**

Harmonic	%
3	7.28
5	6.63
7	5.71
9	4.61
11	3.42
13	2.19
15	1.04
21	1.32
23	1.63
25	1.69
27	1.54
29	1.22

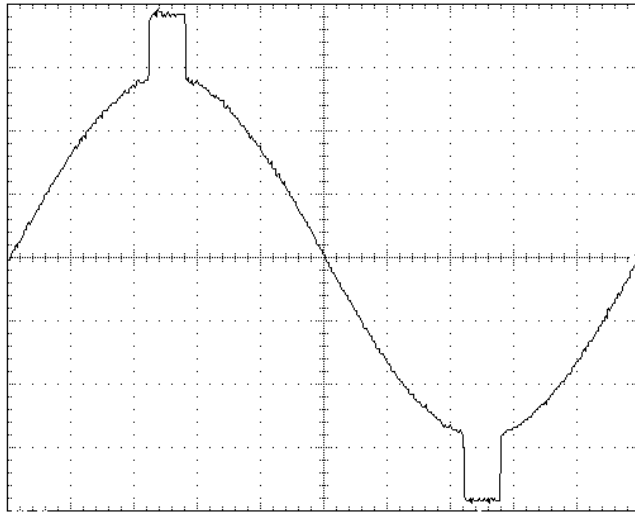

**DST026**

Harmonic	%
5	3.54
7	2.68
11	8.87
13	7.86
19	1.04
23	4.11
25	4.13
35	2.61
37	2.82

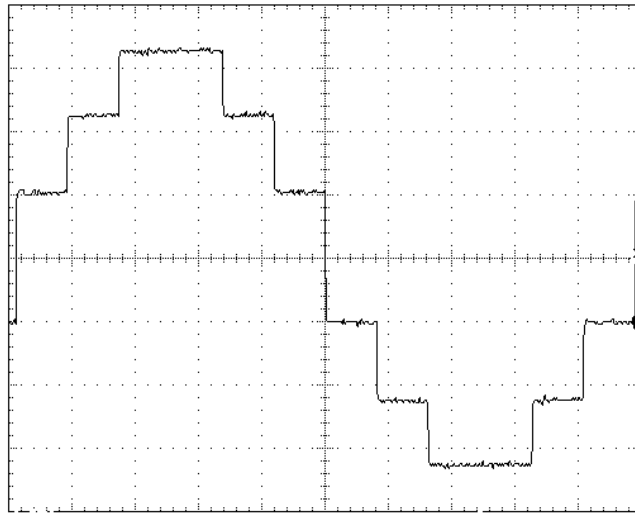

**DST027**

Harmonic	%
21	1.38
23	5.39
25	2.29

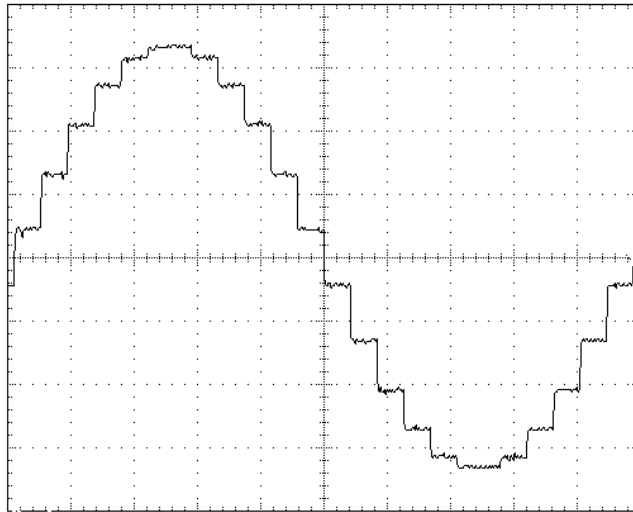

**DST028**

Harmonic	%
3	33.3333
5	20
7	13.8
9	10.8
11	8.5
13	7.2
15	6
17	5
19	5
21	4.5
23	4
25	3.5
27	2.95
29	2.5
31	2
33	2
35	2
37	2
39	2

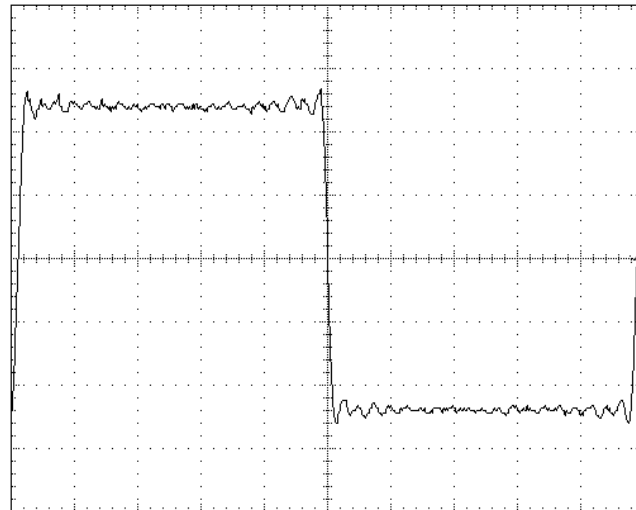

**DST029**

Harmonic	%
3	33.3333
5	20
7	13.8
9	10.8
11	8.5
13	7.2
15	6
17	5
19	5
21	4.5
23	4
25	1
27	1
29	1
31	1
33	1
35	1
37	1
39	1

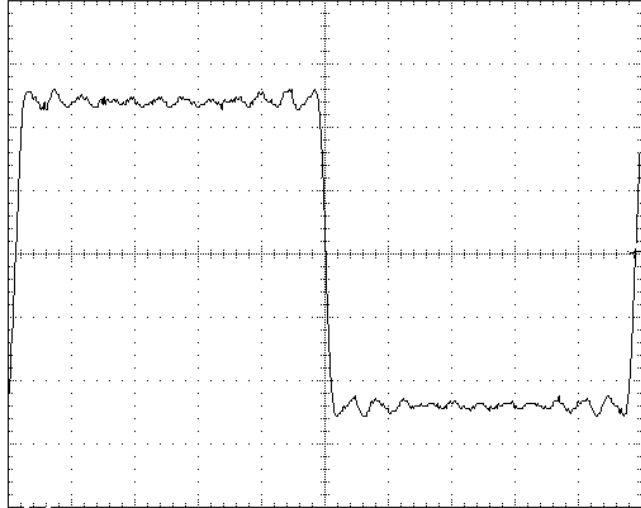

**DST030**

Harmonic	%
3	33.3333
5	20
7	13.8
9	10.8
11	8.5
13	7.2
15	5.5

