

Thermal/Multi-Function Data Logger

Model 51101 Series



It is a general requirement to record temperatures, voltages, currents, and many physics quantities during research, product development, productions, and quality assurance processes. The number of record channels can be a simple one to several complicated set of hundreds. Thermal/multi-function data loggers are perfect solutions to serve for these measurement and tracking needs.

There are several measurement products in the market to perform such a large-scale and extensive time varying recording. Some are expensive, some are limited in accuracy or resolution, and some have low immunity to interference. Chroma thermal/multi-function data loggers are by far the most cost-effective solutions for versatility, accuracy, stability, and interference immunity among this category.

Chroma thermal/multi-function data loggers measure temperatures, voltages, and currents with high accuracy and resolutions. For example, they support 8 types of thermal couples measurement with ITS-90 defined temperature range at 0.3°C accuracy and 0.01°C resolution*, while most data loggers in the market are at 1°C accuracy and 0.1°C resolution*. Chroma loggers are with 1000VDC channel to channel isolation, which means they can attach thermal couples to objects with high electricity, such as batteries, solar cells, working PCB, etc., and still get correct data. Many competitors are just malfunctioned or even damaged in those cases. Data retrieve in Chroma loggers are in a parallel architecture, while most of competitors use a sequential multiplexing method. This means data rate per channel is quick and constant for Chroma loggers, while others become much slower when number of channels is bigger.

Using Chroma thermal/multi-function data loggers, customers get confidence in measured data and high Performance/Cost ratio. Most of all, we can help in certain cases that our competitors fail, and only Chroma succeeds.

KEY FEATURES

- Models with 1, 8, and 64 channels on-line data recording. Multi-sets linked to a PC for hundreds of channels are doable
- Support B, E, J, K, N, R, S, and T type thermal couples with ITS-90 defined temperature range
- Individual channel cold junction compensation with $\pm 0.3^\circ\text{C}$ accuracy
- Temperature resolution up to 0.01°C, error down to (0.01% of reading + 0.3°C)
- Voltage full range $\pm 480\text{VDC}$, $\pm 10\text{VDC}$; resolution 1mV, 10uV; error down to (0.1% of reading + 1mV), (0.015% of reading + 100uV)
- 1000VDC channel to channel isolation, full protection for testing points with charge and guarantee for accurate measurements
- Thermal couple open circuit detection
- PC-based operation with powerful software for recording and analyzing data
- 1 and 8 channel models are USB powered. No battery or external power supply is required

*Thermal couple error excluded. Please see specification list for detail.



1000VDC CHANNEL TO CHANNEL ISOLATION

In developing or qualifying some electronic devices, tracking records of temperatures/voltages/currents are required. Many cases there can be high voltage difference between measured points. A switching power supply, for example, is required to measure the primary side voltage/current, secondary side voltage/current, and key component temperatures. Unfortunately, many data loggers including some leading brands are incapable to handle such a high voltage difference between both sides. Few hundred voltage difference can mess up their measurement totally, or even kills their loggers.

Chroma thermal/multifunction data loggers are perfect for the measurements in a situation with charge and high voltage difference. The feature of 1000VDC channel to channel isolation makes them immune to voltage difference between any two channels. One just attaches thermal couples or wires on the device or conducting pads and gets accurate data.

Another case can be battery system tests. One needs to know the voltage and temperature of each cell. For other data loggers, often the voltages cannot be measured properly in the cascade configuration. The thermal couple attachment is another issue needing special care. All these problems are easily solved using Chroma thermal/multi-function data loggers for the high channel to channel isolation.

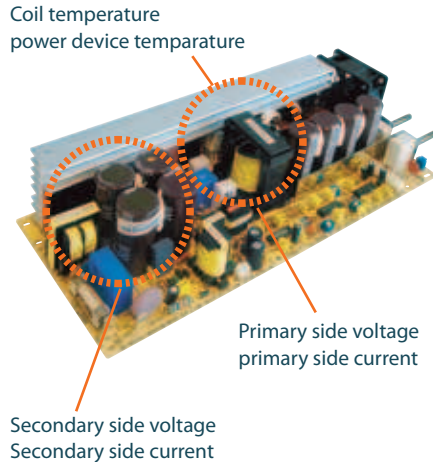

Multi-channel Data Logger

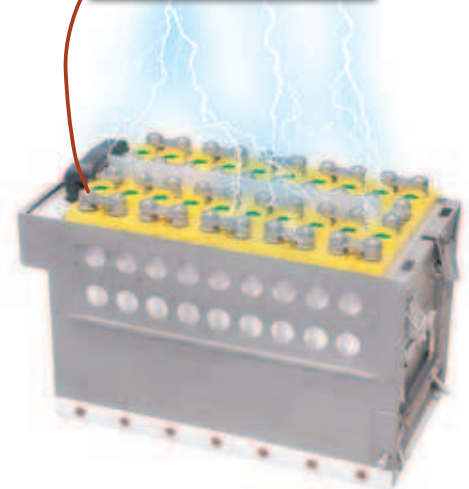

0.3 °C ACCURACY AND 0.01 °C RESOLUTION

For the same or even lower prices, Chroma thermal/multi-function data logger offers higher accuracy and better resolution than our competitors do. While most of data loggers are at 1°C accuracy and 0.1°C resolution, Chroma data loggers are 1 order better than theirs. It is always true the more accurate and seeing more details, the better for measurements.

In order to achieve such high accuracy and resolution, Chroma implements individual CJC for each channel. High bit-count A-to-D converters and advanced noise suppression circuit makes outstanding performance for these data loggers. The best of all is that customers can enjoy better specifications without paying more.

Precise temperatures can be critical in thermal conductivity measurements, chemical processes, and biologic experiments. Testing a heat pipe, for example, often requires resolving <1°C temperature difference between evaporation and condensing zones. Some liquid crystals can change their properties drastically with a very small temperature variation at critical temperatures.

CONSTANT DATA RATE PER CHANNEL

Most of data loggers in the market use a multiplexing circuit structure. All channels share a bandwidth which means the more active channels, the slower data rate per channel will be. Chroma data loggers use a parallel data retrieving circuit structure. No matter how many channels are active, the data rate can be as fast as 5 samples per second per channel.

The benefit of constant data rate can be profound for recording large number of channels. For tens of channels, total data bandwidth of Chroma data logger can be several times larger than that of other data loggers. Some other data loggers can become too slow and lose details. They can miss recording critical changes happen in a short time. Chroma data loggers greatly reduce this possibility.

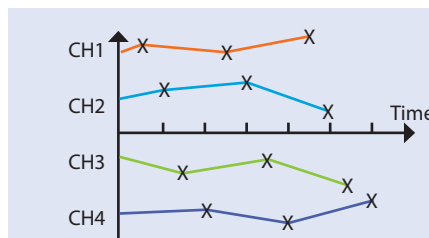

What other data loggers see, more channels, slower rate each channel

$$\text{Sample rate per channel} = \frac{\text{bandwidth}}{\text{number of channels}}$$

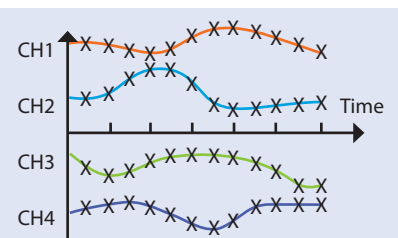

What CHROMA data loggers see, constant rate each channel

$$\text{Sample rate per channel} = \text{constant}$$

POWERFUL DATA RECORDING AND ANALYZING THROUGH A PC

Personal computers and Notebooks are powerful for their fast calculation and data processing capability, friendly graphic user interface, and huge hard disk storage. While operation of many other data loggers are limited by their small display and memory, Chroma data loggers link to PCs or Notebooks for direct display, analyses, and storage.

Using the PC software, one can see the detail of all the curves, change drawing time and range scales, create marks, zoom in selected sections, and perform difference calculations, all in few simple steps. The PC RAM is used as buffer to store every data since the logger is powered on, making data tracking back possible without opening the record file. Size of data recording is determined by hard disk free space, which is almost unlimited.

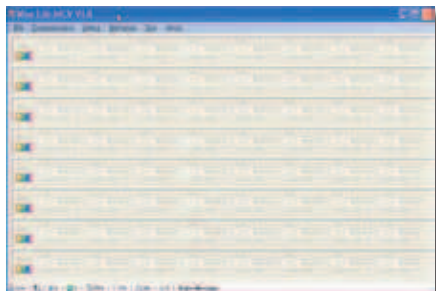

Main panel

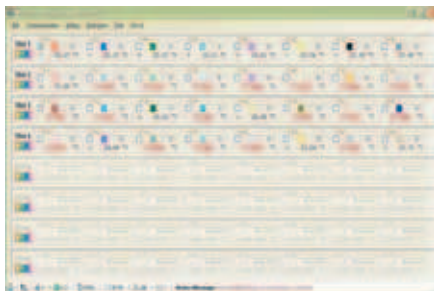

Data panel

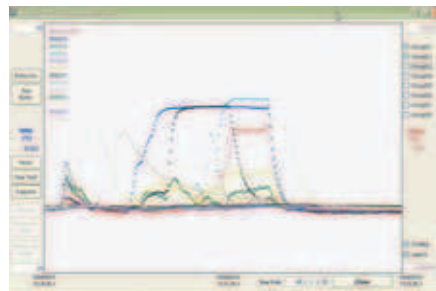

Data Histogram

APPLICATIONS



Automotive & Aircraft

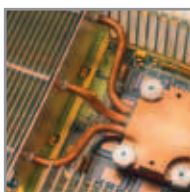

Electrical & Electronics



Solar Energy



Power

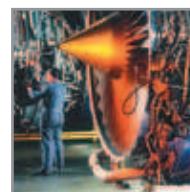

Machinery



Iron & Steel



Metals & Mining



Oil & Gas



Water & Waste



Chemical



Pharmaceutical & Food



Others

SPECIFICATIONS

| Model | 51101-1 | 51101-8 | 51101-64 |
|--------------------------------------|----------------|---------------------------------------|---------------------------------------|
| Thermal Coupler | | | |
| Thermocouple T-type | -200 to 400°C | | |
| Thermocouple K-type | -200 to 1372°C | | |
| Thermocouple B-type | 250 to 1820°C | | |
| Thermocouple E-type | -200 to 1000°C | | |
| Thermocouple J-type | -210 to 1200°C | | |
| Thermocouple N-type | -200 to 1300°C | | |
| Thermocouple S-type | -50 to 1760°C | | |
| Thermocouple R-type | -50 to 1760°C | | |
| Thermocouple Jacks | | B, E, J, K, N, R, S, or T mini-type | |
| Thermocouple Connector | | B, E, J, K, N, R, S, or T mini-type | |
| Temperature Reading | | | |
| Number of Inputs | 1 | 8 | 8, 16, 24, 32, 40, 48, 56, 64 channel |
| Temperature Sensor Type | | Thermocouple : B, E, J, K, N, R, S, T | |
| Temperature Scale | | ITS-90 | |
| Temperature Resolution | | ± 0.01 °C | |
| Temperature Accuracy *1*2 | | ± (0.01% of reading +0.3) °C | |
| CJC Error | | ± 0.3 °C | |
| Maximum Sample Rate | | 5 sample/sec. | |
| Channel to Channel Isolation | | 1000VDC / 750 Vrms | |
| Input Resistance | | 5M Ω | |
| Thermocouple break detection current | | 100 nA | |

SPECIFICATIONS

| Model | 51101-1 | 51101-8 | 51101-64 |
|--|--|-----------------------|--|
| Number of Inputs | 1 | 8 | 8, 16, 24, 32, 40, 48, 56, 64 channel |
| Digital I/O | | | |
| Number of Digital I/O | -- | -- | 4 differential digital inputs and outputs |
| Digital Input | -- | -- | 1 trigger input(DIO) and 3 general purpose inputs |
| Digital Input- High Input Voltage | -- | -- | 3 ~ 30 V |
| Digital Input- Low Input Voltage | -- | -- | < 0.8 V |
| Digital Input- High Input Current | -- | -- | 0.8 ~ 13.1 mA |
| Digital Input- Low Input Current | -- | -- | <10 μ A |
| Digital Input- Terminal Resistor | -- | -- | 2.2K Ω |
| Digital Output Configuration | -- | -- | transistor switch |
| Digital Output- External Supply Voltage | -- | -- | <30 V |
| Digital Output- ON-state Voltage | -- | -- | <1.5 V |
| Digital Output- ON-state Current | -- | -- | <400 mA |
| Digital Output- OFF-state Current | -- | -- | <2.1 μ A |
| Digital Output- Power Dissipation per Output | -- | -- | <0.6 W |
| Isolation Voltage | -- | -- | \pm 250 V |
| Communication | | | |
| RS-232 | -- | -- | Half Duplex, DB-9 female connector |
| USB | USB2.0 (full speed device) ; USB A-type connector | -- | USB2.0 (full speed device) ; USB B-type connector |
| LAN (Option) | -- | -- | Ethernet (10BASE-T/100BASE-TX) ; RJ-45 connector |
| Power Specifications | | | |
| Power Requirement | 4.5~5.5 V | | 11.4~12.6 V |
| Maximum Power Consumption | 0.22W | 1.2W | 18 W |
| Physical Specifications | | | |
| Dimensions (WxDxH) | 96 x 29 x 14.5mm | 135.3 x 186 x 51.7 mm | 277 x 200.7 x 233 mm |
| Weight for Main Frame | 30g | 1.2 Kg | 2.4 Kg |
| Weight per Sensor Card | -- | -- | 0.15 Kg |
| Weight (Main Frame + 8 Sensor Card) | -- | -- | 3.6 Kg |
| Environmental specifications | | | |
| Operating Temperature *1*2 | 0~50°C | | |
| Humidity | < 80 %RH | | |
| Power Adaptor Input Voltage | -- | -- | 90 to 260 VAC |
| Power Adaptor Input Frequency | -- | -- | 47 to 63 Hz |
| Main Frame DC Input | -- | -- | 12.6 V/1.5 A |
| Thermocouple Differential Input Voltage | \pm 2.5 V | \pm 2.5 V | \pm 5 V |
| External Digital Input/Output Voltage | -- | -- | 30 V |
| External Digital Output Current | -- | -- | 400 mA |
| Operating Temperature | 0~50°C | | |
| Storage Temperature | 20~60°C | | |
| Storage Humidity | 80 %RH | | |

Voltage Reading

| Voltage Input Type | VA-480 Voltage Adaptor | VA-10 Voltage Adaptor |
|------------------------|---------------------------------|---|
| Voltage Resolution | 1mV | 10 μ V |
| Voltage Input Range | \pm 480VDC | \pm 10VDC |
| Voltage Input Accuracy | \pm (0.1% of reading + 1mV)*3 | \pm (0.015% of reading + 100 μ V)*3 |
| Input Resistance | 1M Ω | |

Current Reading

| Current Input Type | IA-3 Current Adaptor |
|------------------------|-----------------------------|
| Current Resolution | 1mA |
| Current Input Range | \pm 3A |
| Current Input Accuracy | \pm (1% of reading + 1mA) |

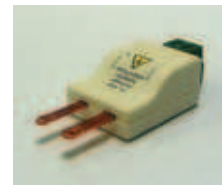

Voltage/Current Adaptor



Thermal Coupler

Note *1 : The accuracy spec is defined as the operating temperature range from 20°C to 30°C, the uncertainty of thermal coupler itself is not included

Note *2 : For operating temperature out of range from 20°C to 30°C, additional error (0.01% of reading + 0.03°C) / °C for that out of operating temperate should be added

Note *3 : Under MV_8 filtering mode

ORDERING INFORMATION

51101-1 : Thermal Data Logger - 1 channel

51101-8 : Thermal Data Logger - 8 channel

51101-64 : Thermal Data Logger - 64 channel

A511000 : VA-480 Voltage Adaptor (option)

A511001 : IA-3 Current Adaptor (option)

A511002 : VA-10 Voltage Adaptor (option)