

# Product Data

## Audio Analyzer — Type 2012

Version 4.0 including Special Calculation Software Type 7661

### USES:

- Development and quality control testing of electroacoustic and vibration transducers: loudspeakers, telephones, headphones, microphones, hearing-aids, hydrophones, accelerometers
- Linear and non-linear system analysis
- Propagation path identification
- Acoustical measurements in rooms and vehicles

### FEATURES:

- Transducer workstation combining the most advanced sine sweep and FFT techniques
- 12" high-resolution colour monitor displays up to 36 curves simultaneously
- Frequency range: 1 Hz to 40 kHz
- Distortion and noise:  $< -80$  dB re full scale input
- Fast time selective measurement of complex frequency and impulse response
- Steady-state response measurements as a function of swept frequency or level

- Automated measurements of individual Harmonic, Intermodulation and Difference Frequency distortion components and total RMS
- 1600 line FFT spectrum
- User-definable Auto Sequences
- Extensive post-processing facilities: +, -,  $\times$ , /,  $1/x$ ,  $x^2$ ,  $\sqrt{x}$ ,  $|x|$ , poles, zeros, windowing, editing, smoothing
- On-screen help in English, French or German
- Preamplifier (microphone) and balanced or single-ended direct inputs
- Two separate built-in sine generators
- Built-in  $3\frac{1}{2}$ " 1.44 Mbyte, PC/MS-DOS compatible floppy disk drive for storage of data, setups, and Auto Sequences and simple loading of complete applications
- Screen copy facility for plotters and printers, both colour and monochrome, direct or via disk
- Upgrade kit from Version 3.0 to Version 4.0 available

The Type 2012 Audio Analyzer is a powerful instrument for transducer measurements and system analysis. It features a colour screen, built-in  $3\frac{1}{2}$ " floppy disk drive, IEEE-488 and RS-232-C interfaces, three measurement modes and an Auto Sequence facility. The Time Selective Response mode enables extremely fast, accurate, swept sine measurements of the free-field response of a transducer in an ordinary room up to the 20th harmonic. The Steady State Response mode enables stepped sine measurements of Harmonic, Difference Frequency and Intermodulation distortion. The 2012 also incorporates a 1600 line single-channel FFT for spectrum measurements.

Type 2012 has numerous post-processing capabilities: windowing, block arithmetic, addition of poles and zeros, square and square root, absolute value, and editing of response data. Applications include development and quality control testing of loudspeakers, telephones, microphones and other electroacoustic and vibration transducers.



Introduction

Audio Analyzer Type 2012 offers three powerful measurement techniques in one instrument. Time Selective Response (TSR), Steady State Response (SSR) and FFT Spectrum (FFT) techniques combined with full complex processing, ensure that Type 2012 will solve almost any electroacoustic measurement problem.

**TSR Mode**

The TSR mode enables “free-field” measurements without an anechoic chamber, by rejecting the reflections from an ordinary listening room. Type 2012 incorporates a technique that allows a useful combination of speed, accuracy and signal/noise ratio for such measurements.

**SSR Mode**

The SSR mode offers comprehensive distortion measurement facilities: Harmonic, Intermodulation and Difference Frequency distortion modes. For band-limited objects, such as electroacoustic transducers, non-linearities cannot be evaluated simply by measuring Harmonic, Intermodulation or Difference Frequency distortion at a few frequencies only. The inclusion of all three distortion modes means that measurements can be made beyond the upper frequency limit of a test object. This is possible because the distortion components will remain inside the working frequency range of the object.

**FFT Mode**

The FFT Spectrum mode has been specially developed for optimum analysis of transient signals in the time or frequency domains.

**Description**

Type 2012 features a 12” high-resolution colour screen. 16 different colours can be selected from a palette of 4096 colours. Setting up the screen format for simultaneous presentation of up to 36 curves on one or two graph fields is very simple with Type 2012, and multiple curves are easily presented by using different colours.

The 2012 is simple to operate. The “soft key” system significantly reduces the number of keys. The keys are organized to give a good overview of the various functions, and logical menus provide a guide for setting up the analyzer. The soft keys are positioned along the right-hand edge of the colour monitor.

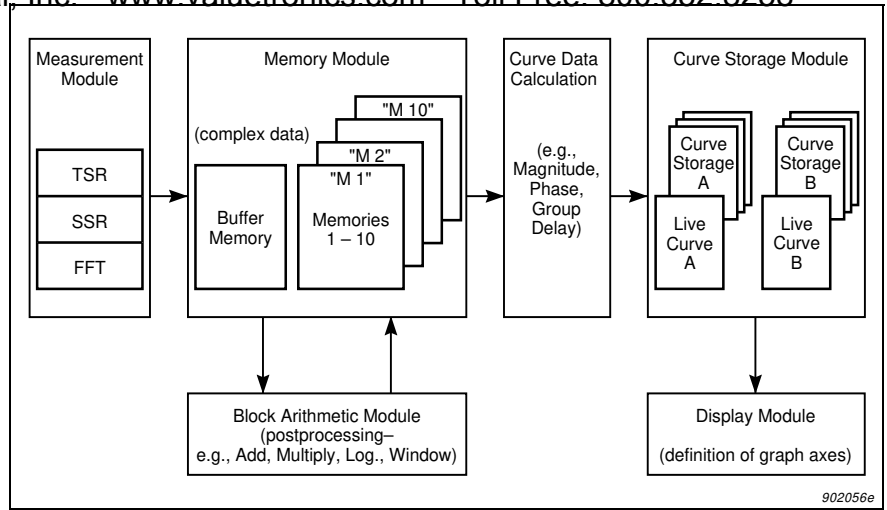

Fig.1 Flow-chart showing the basic data flow in Type 2012. Data from the measurement module are stored as complex numbers in the buffer memory or one of the ten result memories. Graph functions can be calculated and displayed after a measurement is performed

A command-oriented Auto Sequence facility makes it simple to set up the 2012 to perform a specific task. Auto Sequences are edited in a special menu, and are basically a sequence of setup changes or control commands which are executed in the same order as they are set up. The Auto Sequence facility allows you to tailor the operation of the 2012 to a specific application. Five Auto Sequences, each containing up to 100 lines, can be stored in the 2012. Auto Sequences can also be saved or read from a disk.

Measurement data are always stored as complex frequency functions in the measurement buffer or one of the ten result memories — “M1” to “M10”. The data in each of these memories can then be processed further, as complex numbers, using the Block Arithmetic facility. Fig.1 gives an overview of the data flow inside Type 2012.

Measurement results obtained in TSR or SSR mode are calculated as frequency responses. The frequency response is calculated as the transfer function (relative response) or as the response signal only (absolute response). Measurements obtained in FFT mode are calculated as spectra. The scaling of a spectrum can be RMS, Power, ASD (amplitude spectral density), PSD (power spectral density) or ESD (energy spectral density).

The input and output of the analyzer can be calibrated in any desired unit. Once calibrated, the 2012 level settings refer directly to the signal at the terminals of the measurement ob-

ject. An autorange function exists for setting the optimum input gain.

For most applications the 2012 is a self-contained instrument. It has both direct and microphone inputs and two separate built-in sine signal generators for excitation. The Direct Input can be used balanced or single ended. The “Preamp. Input” is used for connecting a standard B&K microphone preamplifier and measuring microphone.

Graphic presentation and documentation are set up in the Screen Format menu. This menu has comprehensive facilities for documentation and hard copies of parameter overviews for measurements can easily be made. Two screen pictures with a total of 36 graphs can be stored simultaneously. The Graph menu is used for setting up the parameters for the frequency and time domain functions. Any desired graph function can be displayed after a measurement has been performed. A set of graph data is calculated based on the parameters in the Graph menu and the measurement data from the measurement buffer or one of the result memories. The flexibility of the graph axis parameters and the possibility for individual graph annotations give great freedom for viewing and documenting the results.

A standard “QWERTY” keyboard is delivered with the 2012. It is used for entering text on graphs and for personal comments on a text page. The keyboard can easily be changed to include German or French characters. The analyzer is supplied with English, German and French program

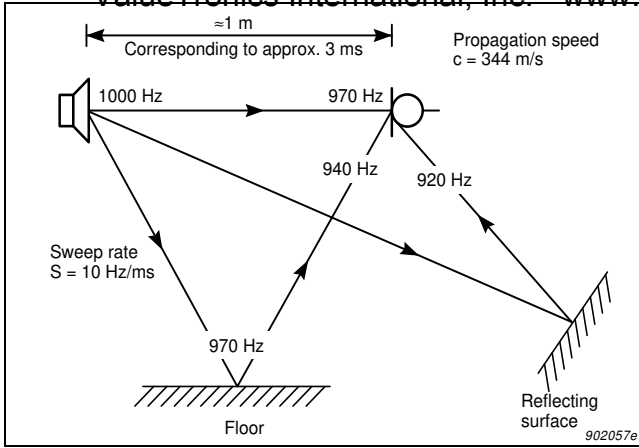

Fig.2 The Time Selective Response mode allows the free-field response of a loudspeaker to be measured in an ordinary room. A linear sweep is used for excitation. Various delays are converted into frequency shifts proportional to the delay and sweep rate S. The figure shows the instantaneous frequencies at the moment in time when the generator is at 1000Hz

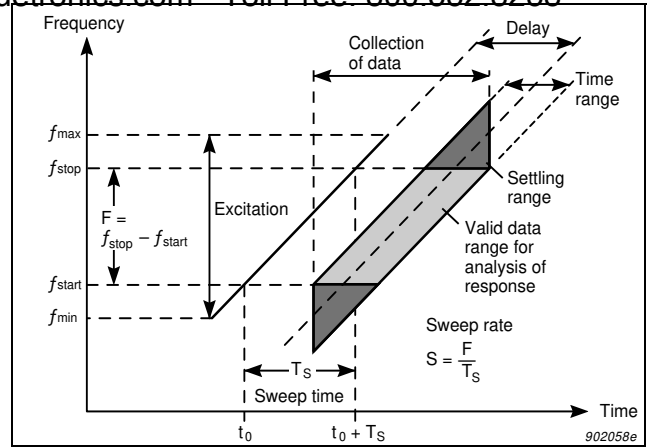

Fig.3 The 2012 measures the fundamental frequency or selected harmonic (up to the 20th), in TSR mode. The light raster area represents the data which are actually used for analysing the response. The sweep range is automatically increased to eliminate "edge effects". The triangular dark raster areas represent the extra data. The width of the data area is given by the Time Range which is equivalent to the length of the time window

disks. This gives the option of selecting English, German or French characters, as well as displaying help pages in the desired language.

The 2012 has extensive on-line help facilities. One status and error-message line appear at the bottom of the screen to give immediate help or warning about the button which has just been pushed. A comprehensive full-screen help page can be obtained by pressing "Help" and then pressing the key for which help is required.

## Measurement Modes

A Mode menu is used for selecting either the TSR, SSR or FFT measuring mode, or one of the five Auto Sequences. Measurements are always performed in the mode selected in the Mode menu.

Separate measurement and display processors allow the analyzer to be quickly set up for another measurement — even while a measurement is in progress.

## Time Selective Response

The TSR mode employs a technique for measuring a time-selective frequency response using a linear continuous sine sweep with constant or frequency-weighted amplitude. The main advantage of this technique is its capability of rejecting noise and reflections, even with short measuring times.

One of the main applications of the TSR mode is the simulated measurement of free-field response, for example, in evaluating loudspeakers in a normal reverberant environment, thus avoiding the use of an expensive anechoic chamber. One of the properties of TSR is that the magnitude and phase responses are available in both the time and the frequency domains. Both the frequency and the time domain responses are typically available almost instantaneously.

The driving signal used for TSR is a linear sine sweep, i.e. the instantaneous frequency is linearly related to time. This linear sweep links time and frequency together in such a way that a selection in time — and consequently in space — can be obtained by filtering in the frequency domain, see Fig.2. An advanced detector algorithm ensures that the response is calculated correctly, independent of the selected sweep time.

The synchronism between the excitation signal and the filter tracking the response provides the 2012 with an inherently good signal/noise ratio. The TSR technique offers the optimal combination of signal/noise ratio and measuring time, for almost any practical measuring situation. The basic

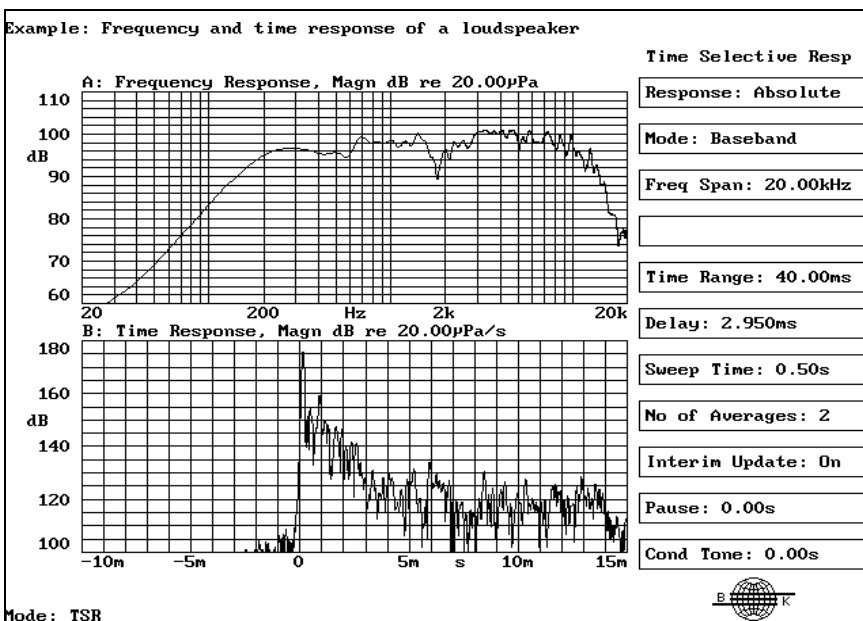

Fig.4 TSR menu with dual graph display. The upper graph shows the frequency response for a small loudspeaker measured at 1m distance. The lower graph shows the time response (magnitude of the impulse response) for the same measurement

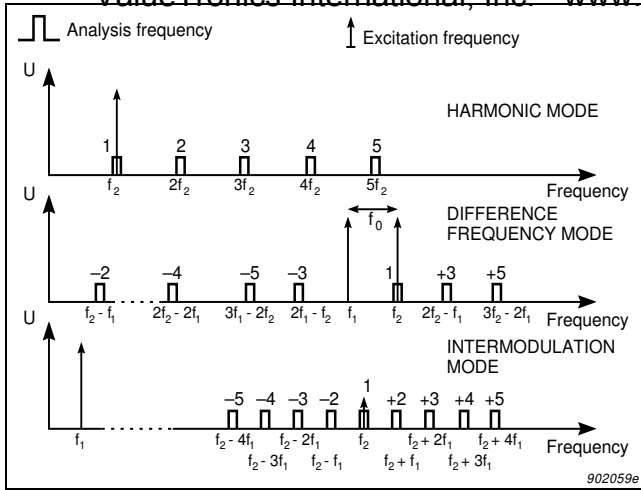

Fig. 5 Harmonic distortion, Difference Frequency and Intermodulation distortion can be measured selectively using stepped sine excitation in Steady State Response mode, or a broadband total RMS value, including distortion and noise, can be measured

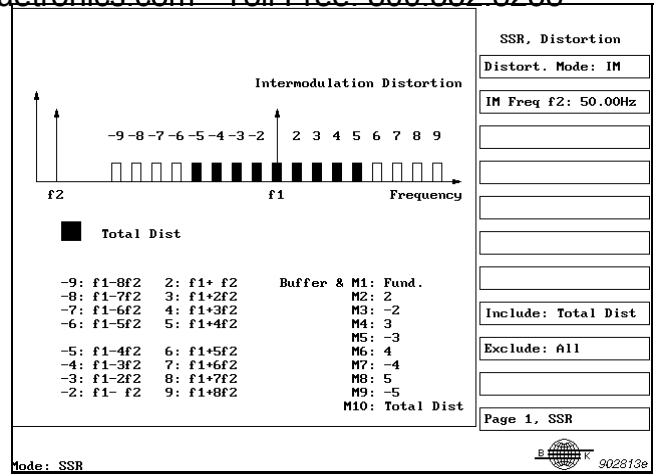

Fig. 6 SSR Intermodulation distortion menu and graphical presentation for setting up the parameters for measuring Intermodulation distortion. This menu is set up for measuring the fundamental, the Intermodulation distortion orders 2, -2, 3, -3, 4, -4, 5, -5 and Total Distortion

parameters which must be considered when setting up a TSR measurement are: Frequency Range, Delay, Time Range, and Sweep Time. The relationship between these parameters is illustrated in Fig. 3. Delay is the time between excitation of the measuring object and collection of the measurement data. Time Range is equivalent to the length of the time window for the measurement. Sweep Time is the time it takes to perform a sweep covering the specified frequency range, i.e. the effective measurement time. When performing a measurement, the sweep range entered is automatically increased to keep unavoidable "edge-effects" outside the frequency range of interest (see Fig. 3). Choosing a longer sweep time, will improve the signal/noise ratio proportionally. Hence the sweep time should be chosen so that the noise is sufficiently suppressed. Normally this can easily be obtained with sweep times of the order of a few seconds. A number of averages (1 to 1024) can also be specified to improve the signal/noise ratio which only depends on the total effective measurement time.

Two basic modes can be selected - Baseband or Zoom. In Baseband mode the fundamental is measured over the entire frequency range up to a specified upper frequency limit. In Zoom mode the fundamental or harmonic up to the 20th order is measured over a frequency interval specified by a start and a stop frequency. In Zoom mode the sweep can be made in both directions depending on the specified start and stop fre-

quencies. The position of the time window can be varied around the measured impulse response to compensate for large propagation times in the measured object. Fig. 4 shows the TSR Setup menu with a dual graph display.

### Steady State Response

The SSR mode employs a technique for measuring a steady state response using stepped sine excitation. The response can be measured as a function of the excitation frequency or it can be measured as a function of the excitation level. The measure-

ment can use an adaptive scan algorithm or linear averaging. The adaptive scan algorithm means that the steady state response is measured to the user-specified accuracy in the minimum possible time. Linear averaging averages the response of each excitation step over a specified period of time.

For measuring frequency responses, SSR mode is desirable for measurements at a number of single frequencies. The distribution of the excitation frequencies for an SSR measurement can be linear, logarithmic or user-defined.

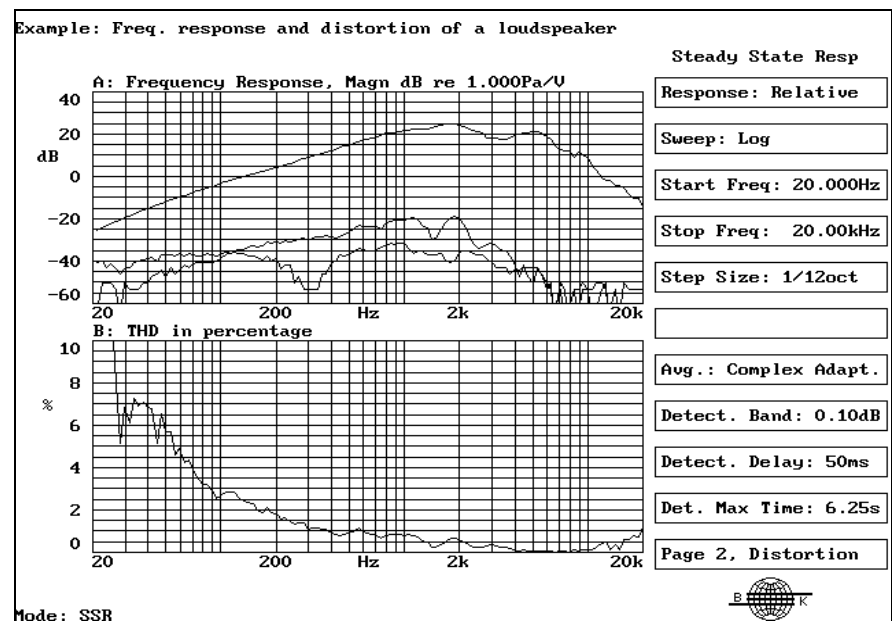

Fig. 7 SSR menu with dual graph display. The upper graph shows the near-field frequency response for a mid-range driver, and also includes the 2nd and 3rd harmonics. The lower curve shows the corresponding Total Harmonic Distortion as a percentage

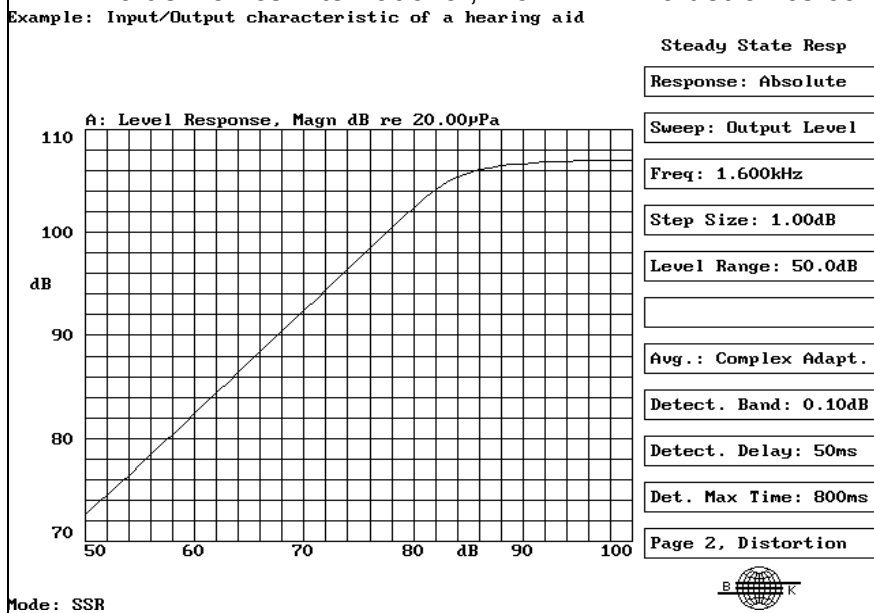

Fig. 8 SSR menu with single graph display. The graph shows a level response of a hearing aid. The level response (sometimes referred to as the I/O Characteristic) shows the output level of the hearing aid as a function of the acoustic excitation level for a single frequency

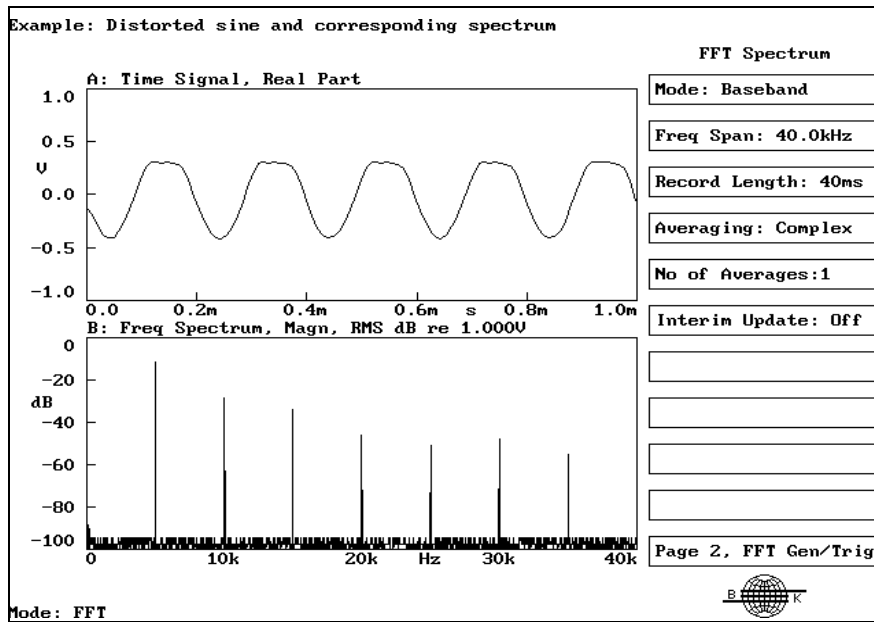

Fig. 9 FFT menu with dual graph display. The FFT mode allows single-channel measurements with excitation from the internal sine generators. The upper graph shows a 5 kHz sine signal distorted by asymmetric clipping. The lower graph shows the spectrum of the same signal

A stepped sine signal is used for excitation in SSR mode. If the adaptive scan algorithm is selected, the response is automatically sampled at each excitation frequency or level until the response has stabilized to within the specified accuracy. In this way the measurement is optimized in the minimum time for a given accuracy. If linear averaging is selected, a well

defined average is calculated for a specified period of time at each excitation frequency or level.

The measurement can operate on either complex or power data. Complex data provides phase information on the response and excellent noise suppression. Power data ignores any phase information providing accurate results, even if the test object has a varying delay.

The SSR mode also incorporates extensive facilities for measuring distortion. Graphical menus make it easy to set up the system to perform measurements of Harmonics, Difference Frequency and Intermodulation distortion as well as measurements of the total RMS response including noise and distortion. Fig. 5 illustrates the Harmonic, Difference Frequency and Intermodulation distortion modes.

Harmonic distortion mode can include any harmonic up to the 20th. Total (including fundamental), Total Distortion (not including fundamental) or THD can also be specified in this menu.

Difference Frequency distortion is measured by exciting the system with two test tones of constant or weighted amplitude,  $f_1$  and  $f_2$ . The two tones are stepped through the frequency range of interest, while keeping a fixed frequency difference between them.

Intermodulation distortion is also measured by using two test tones,  $f_1$  and  $f_2$ , with constant or weighted amplitude.  $f_2$  is kept at a fixed low-frequency, while  $f_1$  is stepped through the frequency range of interest. One of the main advantages of Intermodulation and Difference Frequency distortion measurements is that they can be used for measurements beyond the upper frequency limit of a system, (since the resulting distortion components remain inside the frequency range of the system). Fig. 6 shows the Setup menu for measuring Intermodulation distortion.

Fig. 7 and 8 show the menu for setting up the basic SSR parameters for a frequency response measurement and a level response measurement respectively. Responses measured can be calculated as the transfer function (relative response) or as the response signal only (absolute response). A frequency sweep or a level sweep can be selected. Linear, logarithmic or user-defined distributions of excitation frequencies can be selected for a frequency sweep. Step size can be set to  $1/3$ ,  $1/6$ ,  $1/12$ ,  $1/24$ ,  $1/96$ -octave and Progressive, i.e. starting with the  $1/3$ -octave excitation frequencies, then adding the remaining frequencies to make a  $1/6$ -octave measurement and so on until all the  $1/96$ -octave frequencies have been measured. Next, the parameters used for averaging are specified: selection of adaptive or linear averaging using either complex or power data, accuracy, delay and averaging time.

**Fast Fourier Transform**

In FFT Spectrum Mode an FFT algorithm is used for measuring the spectrum of a signal from a test object. The test object may be excited from the internal sine generators in Type 2012.

The single-channel FFT mode is suited for the analysis of continuous signals and for transient signals, where the entire signal to be analyzed fits into the analyzer memory. The FFT mode can be advantageous for measuring, e.g., background noise, telephone dialling tones, attack/release times of compressor circuits or for a quick evaluation of nonlinearities in a test setup.

Two basic modes can be selected — Baseband or Zoom. In Baseband mode the 2012 produces an FFT spectrum with a frequency resolution of up to 1600 lines, based on 4096 samples in the time function. In Zoom mode (high-resolution mode) a particular center frequency can be selected, and a bandwidth from 1.56Hz to 1600Hz can be specified to “zoom” in on this frequency. The resolution in Zoom mode is always 513 lines, based on 1024 time samples. Averaging is used to obtain a statistically reliable result by reducing the effects of random variations. Complex amplitude averaging or Power averaging can be selected. Fig. 9 shows the FFT Setup menu where a dual graph display is used to illustrate a time signal and its corresponding spectrum.

**Auto Sequences**

An Auto Sequence is a user-defined sequence of front panel functions. On the screen, it appears as a three-column list, including the hard key label, the soft key label and the parameter value (if any), which together constitute the equivalent IEEE-488 bus commands. A “learn mode” is used to make this list by simply pushing the desired keys. Any front panel function, including calling another Auto Sequence, can be executed with an Auto Sequence. Fig. 10 shows an Auto Sequence which will perform a TSR measurement of the fundamental and the 2nd and 3rd harmonic distortion components, display the curves on the screen and finally make a hard copy of the screen picture.

Conditional and unconditional loops can be set up and branching can be specified. Branching is con-

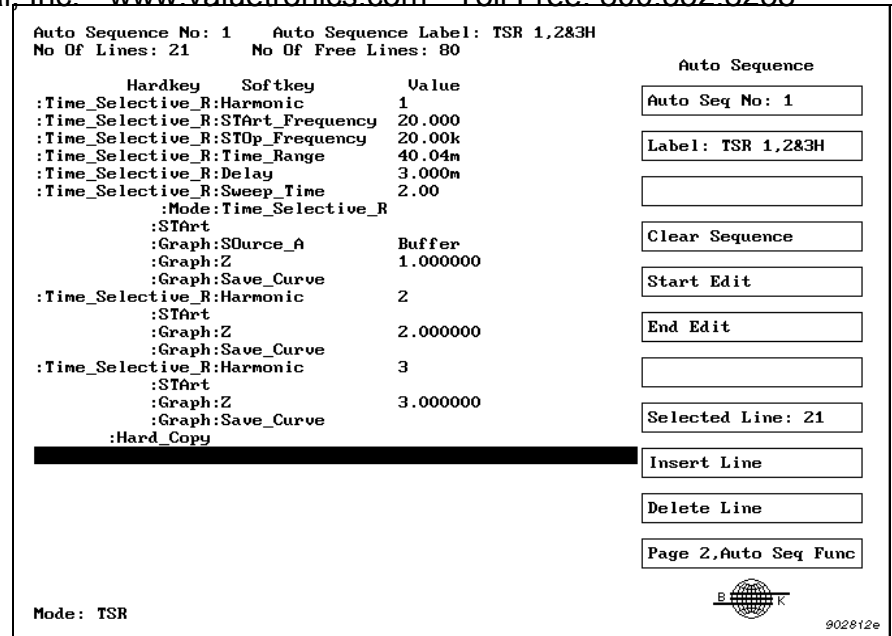

Fig.10 Auto Sequences are listed using the equivalent IEEE-488 bus commands. This Auto Sequence will perform a TSR measurement of the fundamental and the 2nd and 3rd harmonic distortion components, display the curves on the screen and finally make a hard copy of the screen picture

trolled using If-Then-Else commands. Looped execution can be established using the “Do” command. Loops can be performed a fixed number of times or as long as a specified condition is fulfilled.

In addition, IEEE-488 interface commands that do not have an equivalent front panel function can be keyed in from the external keyboard.

The position of the cursor can also be controlled from an Auto Sequence, and cursor values can be transferred to, added to or subtracted from parameter values.

Comments can be inserted into Auto Sequences, as well as messages and warnings to be displayed in the status line on the screen during execution.

Execution of Auto Sequences can be carried out in either Single Task or Multitasking mode. In Single Task mode each command line is executed before the next. This ensures an exactly sequential execution. For special purposes, multitasking can be selected, making use of the analyzer’s parallel analysis capabilities.

The 2012 is supplied with a disk with a number of Auto Sequences which makes up a tutorial guide.

**Processing**

**Memory**

Type 2012 has a 4Mbyte internal memory with a battery back-up for permanent storage of data. The continuous memory is used for storing the program source, a complete parameter setup, five Auto Sequences, 11 complete result memories, two separate screen pictures (Graph A and Graph B) with up to 36 curves and user-defined text.

The content of the internal memory is used whenever the 2012 is switched on without the program disk in the disk drive. Switching on or resetting the instrument with the program disk in the disk drive will update the main program and reset all data. Changing between English, German or French help pages and characters, is simply a matter of loading the desired version of the program disk.

**Block Arithmetic**

The Block Arithmetic menu is used for post-processing operations yielding a complete response function or spectrum as a result. All measurement data are stored as complex numbers, i.e. with real and imaginary parts, allowing full complex

processing to be performed. Data in any of the 11 result memories can be post-processed. The result is a new set of data which can be stored in any of the result memories. The list of post-processing operations are:

- Copying data between the 11 result memories.
- Multiplying data with a frequency or a time window (Hanning, Rectangular or Rectangular with Hanning Taper)
- Addition and Subtraction (in the frequency domain)
- Multiplication and Division (in the frequency domain)
- Time shifting (linear phase shift in the frequency domain)
- Changing polarity (180° phase shift)
- Calculating the reciprocal (in the frequency domain)
- Calculating the absolute value
- Calculating the square and square root of the amplitude in the frequency domain
- Calculating exponents
- Calculating natural logarithms
- Adding poles/zeros
- Editing values
- Converting data to a user-defined frequency format

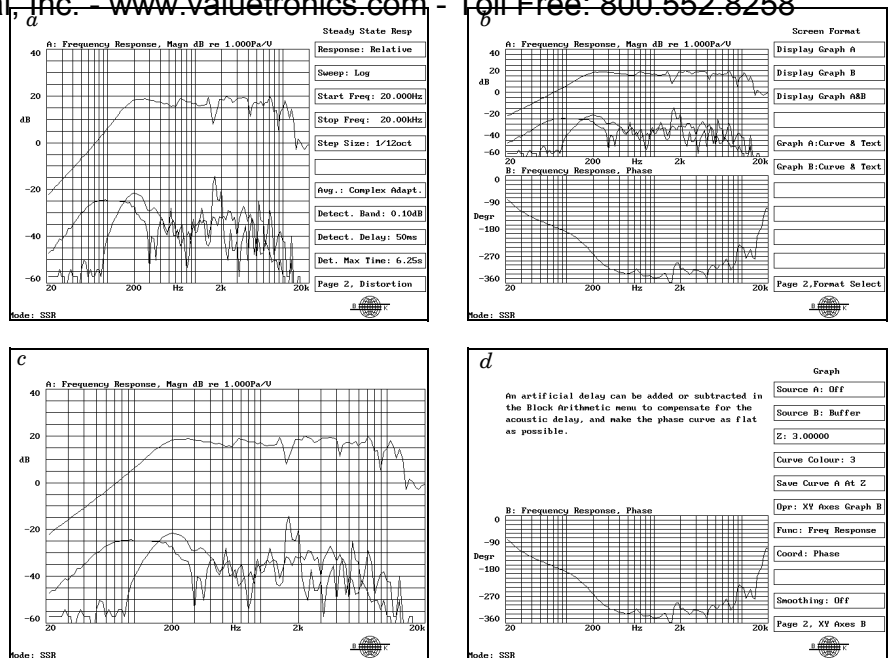

Fig.11 Examples of different screen formats which can be selected in the Screen Format menu.

- a) Graph A format for displaying a single graph area with up to 36 curves
- b) Graph A & B format for displaying a dual graph with Graph A at the top of the screen picture and Graph B at the bottom
- c) Full screen graph (no menu)
- d) Graph and Text page on the same screen picture

## Display

### Screen Format

Measurement results can be displayed in various formats. Different graph formats are shown in Fig. 10. The Screen Format menu is used to set up the different formats: Graph A (and Graph B) display a single graph area for showing up to 36 curves simultaneously. Text can be superimposed on the graph field, or a full text page for user-defined text can be selected. Graph A & B gives a dual screen format to display Graph A (upper) and Graph B (lower) simultaneously.

Fig.11 and 12 show some of the screen formats which are also used for documentation. Graph Only is used to give an enlarged graph field which takes up the whole screen; no menu is shown. Full TSR, SSR or FFT Setup gives a complete screen overview of the parameters for the respective menus, together with the parameters from the Level, Input and Output menus. Graph and TSR, SSR or FFT Setups give the parameters for the respective menus together with the Level menu and a graph field.

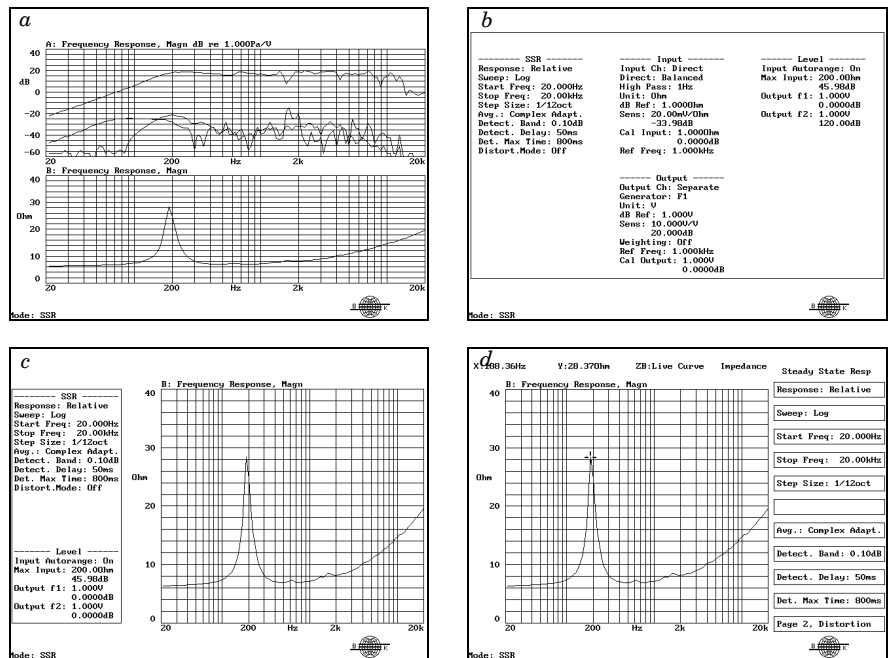

Fig.12 The different screen formats offer the possibility of documenting measurements. When a hard copy is made it is a reproduction of what appears on the screen.

- a) Graph Only format expands the graph field to cover the entire screen (no menu is shown)
- b) Full TSR/SSR/FFT Setup format is used for displaying the parameters from the Input, Level and Output menus
- c) Graph and TSR/SSR/FFT Setup format is used for displaying the parameters from the respective menus together with parameters from the Level menu, on the left-hand side of the screen. The graph is shown on the right-hand side. No menu is shown
- d) Frequency and amplitude values can be read out directly in all formats using the cursor

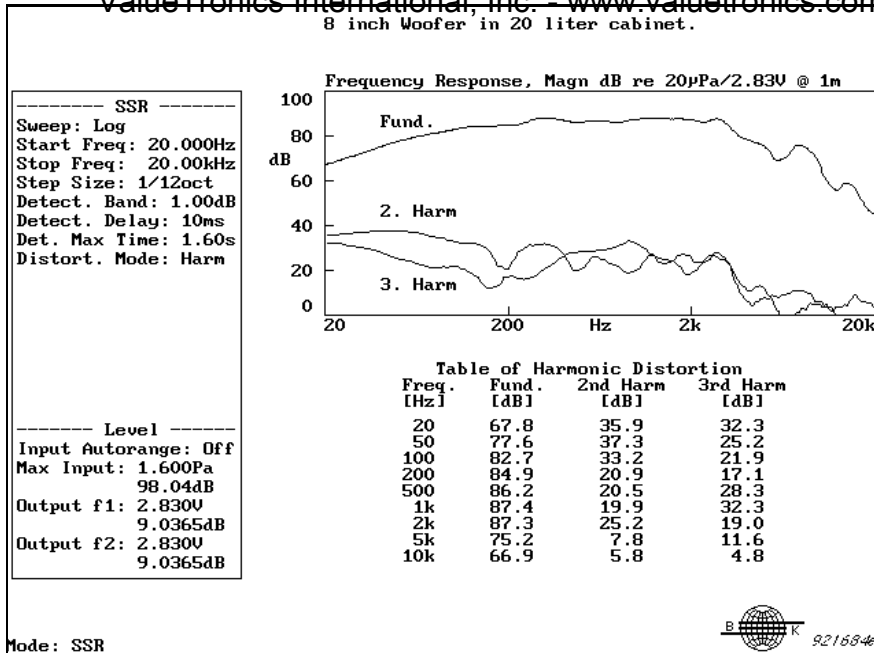

Fig. 13 Curve References can be used for setting up a complete table in a graph text. The table above lists the harmonic distortion in dB at selected frequencies



Fig. 14 Input/output panel of the 2012, showing the 7-pin Preamplifier Input for connection of Brüel & Kjær condenser microphones, and the Direct Input which can be single ended or differential (balanced)

**Graph**

The Graph menu is used for selecting the parameters for presenting measurement data in a system of coordinates. The desired function and the real coordinate to be displayed are selected in this menu. Selecting and calculating the frequency and time domain functions after the measurement has been done, allows measurement data to be displayed in a number of ways. The following functions and coordinates can be selected:

**Functions:**

- Frequency Response
- 1/3-octave Response
- Time Response
- Response Decay
- Frequency Spectrum
- 1/3-octave Spectrum
- Time Signal
- Signal Decay
- Auto Correlation (only for spectra)
- Level Response

**Coordinates:**

- Real Part
- Imaginary Part
- Magnitude
- Phase
- Group Delay
- Instantaneous Frequency

**Graph Text**

The Graph menu can also be used to enter user-defined text to be displayed on the screen. Text pages can be entered in the graph area of the screen. This text can be displayed super-imposed on the graphs, or as pure text with no underlying graph. Text can be emphasized using user-defined text and background colours. This makes it possible to customize operator instructions or documentation. A special feature is the “dynamic” graph text facility enabling curve values and text strings to automatically be updated, see Fig. 13. This is accomplished by inserting coded references (Curve References) into the

text. X, Y and Z values, Special Calculation values (Type 7661 only) and text strings are then automatically transferred to the display. This is particularly useful for making report-ready documentation. For example, you can set up the analyzer to make individual specification sheets with a general text and all the relevant values will automatically be inserted into the text (e.g., set up as a table) when the actual measurements are made.

**Cursor**

The cursor is used for reading out the exact x- and y-coordinates of a point on a curve. The cursor x- and y-values can be transferred to a parameter field by using the “Cursor Value” key.

**Input/Output**

The 2012 has been designed to meet the most stringent accuracy specifications. Therefore the advanced measurement algorithms are matched by very high-grade input and output circuits. To ensure that the initial specifications are maintained throughout the operating life of the 2012, a thorough, accredited calibration is available as a separate service (see the specifications section for further details).

**Analogue Inputs**

The 2012 has a direct input for voltage signals and a standard Brüel & Kjær preamplifier input. Both inputs have a dynamic range of more than 80dB and an input signal range from 0.2µV to 100V peak. A range of high-pass filters can be selected for both inputs. Auto-ranging can also be selected for both inputs. The input/output panel on Type 2012 can be seen in Fig. 14.

*Microphone/Preamp. Input*

The 7-pin Brüel & Kjær Preamplifier Input socket supplies power for the microphone preamplifier, and has a 200V polarization voltage which can be switched off for use with prepolarized condenser microphones.

*Direct Input*

Voltage signals are connected via a BNT socket which also accepts BNC cables. The input can be single ended or differential (balanced) which gives a common mode rejection ratio of >70dB at 50/60Hz, enabling the high sensitivity of the preamplifier to be





Fig.15 Type 2012 is ideal for transducer measurements. The setup in the picture uses the Laser Transducer Set Type 3544 for measuring the Thiele-Small parameters. Use of the laser enables measurements without the mass-loading effects of an accelerometer

used even in the presence of common mode noise signals at the input.

#### Analogue to Digital Conversion

The anti-aliasing filter used in Type 2012 is a nine-pole elliptical, low-pass filter, which provides more than 80dB attenuation of input frequencies which can cause aliasing. The filter can be bypassed in FFT mode. 14-bit analogue to digital conversion provides a dynamic range of >80dB.

#### Trigger Functions

The 2012 has a flexible trigger function for use in FFT mode. Delays, from -4 to 32 seconds can be selected, depending on the frequency range. The options available for starting a measurement are:

**Free Run:** Averaging begins as soon as the "Start" button is activated.

**External Trigger:** Averaging is initiated by an external trigger signal, with selectable time delay. The trigger input is via a BNC socket on the front panel.

**Internal:** Averaging starts when the input signal passes a certain level. The trigger slope can be positive or negative, and the trigger level can be set from -100% to +100% of the selected input value.

**Generator:** Averaging begins when a generator signal with a positive slope crosses zero level.

#### Signal Generators

Type 2012 is equipped with two separate sine generators. The outputs of the generators are either fed to two separate BNT connectors ( $f_1$  and  $f_2$ ) on the front panel (accepts BNC plugs), or are summed and fed to a single BNT connector ( $f_1 + f_2$ ).

The output can be set directly in terms of the desired working units, e.g. Pa,  $ms^2$ , once it has been calibrated. Separate calibration values for "separate" and "common" output modes can be stored. An automatic calibration can be performed with an externally measured output signal.

The frequency and level of the generators can be controlled directly with a Manual Generator feature.

The output and input levels are displayed graphically on the screen.

It is also possible to apply a weighting to the generator output. This feature can be used for example, to keep the sound pressure level from a loudspeaker constant over a specified frequency range. This is achieved by specifying the inverse response of the loudspeaker as weighting for the generator output.

#### Remote

An 8-pin socket accepting a standard DIN plug is fitted on the back panel for remote control. The following functions can be controlled via the remote control socket: Start, Stop, Proceed and Continuous. One pin is used to indicate a "Busy" state and one pin is used for a user-defined indication controlled by softkeys.

## General

#### Disk Drive

A 3 $\frac{1}{2}$ " high-density floppy disk drive is built into the 2012 for permanent storage of parameter setups, sets of measurement data, Auto Sequences, screen pictures with curves, and user-defined text. The disk drive can handle 720Kbyte and 1.44Mbyte disks, and is PC/MS-DOS compatible.

The Disk Input/Output menu can be used to display a list of files on the screen, and to perform the following functions:

- Store
- Recall
- Delete
- Protect
- Unprotect
- Rename
- Copy
- Format

In addition to these standard file operations, the Reset menu includes a customize function allowing complete setup of the analyzer (with one keystroke) for a specific application. This is particularly useful when the analyzer is being operated by several users.

#### Screen Copy

A copy of the present screen picture is obtained by pressing the Screen Copy key on the front panel. A hard copy file can be output to the IEEE-488 bus, the RS-232 bus or can be stored on a floppy disk. The 2012 is supplied with a number of setups for commonly used multi-colour pen-plotters, matrix printers, ink-jet printers and laser printers. If a non-

standard printer or plotter is used, there is provision for setting up all printer or plotter parameters in the Interface menu.

**Analogue/Digital Self-test**

A comprehensive analogue/digital self-test can be performed to ensure proper operation of the analyzer. During the self-test the 2012 checks its analogue and digital functions. Should a failure occur, a comprehensive error code system can be used to pinpoint the fault. This minimizes downtime.

**Interfaces**

**IEC/IEEE-488 Interface**

The IEC/IEEE interface conforms to IEEE-488.1 and IEC 625-1 standards. All functions on the display, except those concerning IEEE controller functions, can be transmitted to and from Type 2012. This includes setup, measurement data, display data, Auto Sequences and a hard copy output. Type 2012 can also be used as a system controller via the IEEE-488 interface.

**RS-232-C Interface**

The RS-232-C interface conforms to EIA Standard RS-232-C (equivalent to CCITT V24). This interface is standard on a number of printers and plotters and is fairly simple to set up. To make a hard copy, the Interface menu for the printer or plotter must be set up for RS-232. Baud rates between 300 and 19200 can be selected.

**Keyboard**

A standard "QWERTY" type keyboard is supplied with Type 2012 for entering text on graphs and for entering file names. Extra keys are supplied with the keyboard so it can be easily changed to include German or French characters.

Loading the desired language for the help pages automatically changes the interpretation of the characters. The keyboard is connected to the front panel via a DIN-connector.

**Monitor**

Measurement results are presented on a 12" high-resolution colour screen. The frame frequency can be set to either 50 or 60Hz to avoid interference with other mains operated equipment. An external RGB monitor can be connected via a D-range socket on the rear panel.

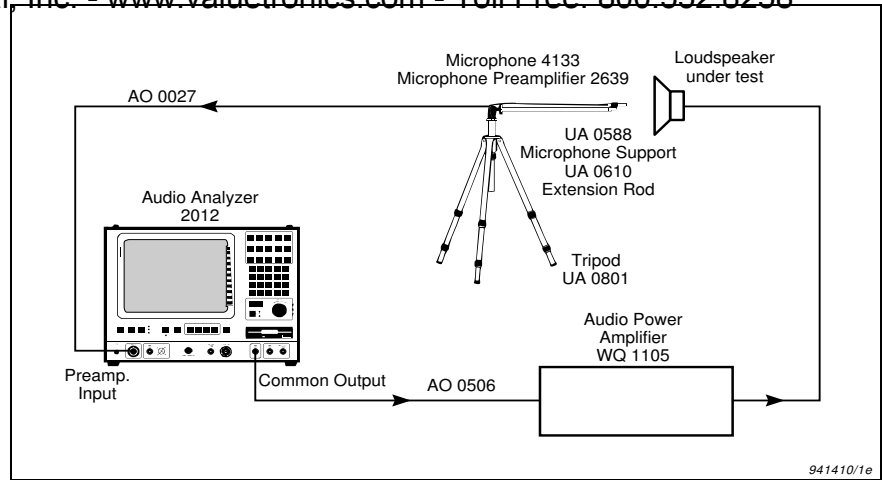

Fig. 16 System setup for performing loudspeaker measurements with Type 2012

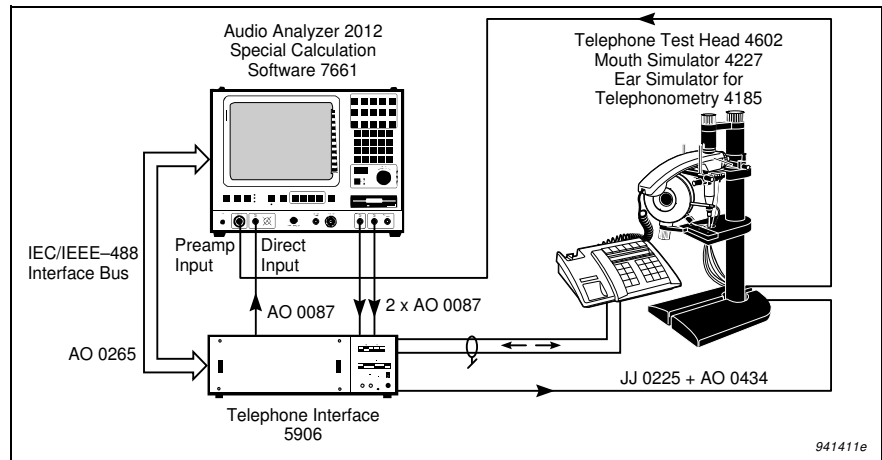

Fig. 17 System setup for performing telephone measurements with Type 2012

**Applications**

To demonstrate the use of the analyzer in various applications, a number of examples based on autosequences are supplied with the analyzer. These examples cover generic applications within the areas of loudspeaker, telephone and hearing-aid measurement. However, the potential of the analyzer as a stand-alone test system as well as a part of a computer controlled system reaches far beyond these generic examples. The typical applications for the analyzer are:

**Loudspeaker Measurements**

Fig. 16 shows a simple setup for making loudspeaker measurements with Type 2012. Using the TSR technique, free-field measurements can be performed without an anechoic chamber.

Analysis of cabinet diffraction can be made in the frequency and time domains. Changes in cabinet design can easily be assessed by displaying the two curves simultaneously in different colours, or by subtracting the curves and displaying the difference. For R & D work, the 2012 can be used for measuring the magnitude and phase of a loudspeaker's electrical impedance over its entire frequency range. For quality testing, the impedance can be measured at a single frequency.

The SSR technique in the 2012 has extensive facilities for making swept Harmonic, Intermodulation and Difference Frequency distortion measurements. These measurements can also be performed at different excitation levels. Defects, such as a rubbing voice coil, can easily be detected using the FFT Spectrum.

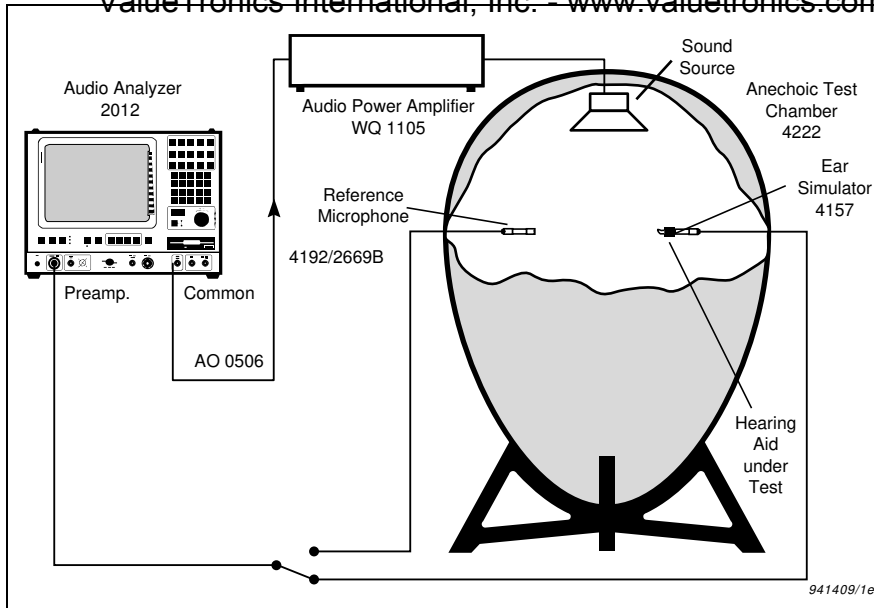

Fig. 18 System set-up for performing hearing aid measurements with the Audio Analyzer Type 2012

Apart from its use as a stand-alone system for development and quality assurance purposes, the 2012 is the central component of several PC-controlled conformance test systems which combine specific national and international standards. Separate product data sheets are available for these systems.

**Microphones**

The output weighting facility of the 2012 can be used to obtain a sound source with a flat frequency response for testing microphones. Type 2012 can be used for free-field (reciprocity) calibration of microphones. The separate generator outputs ( $f_1 + f_2$ ) enable measurements of Intermodulation and Difference Frequency distortion. Variations in the directional characteristics can be displayed for up to 36 different angles simultaneously.

**Hearing Aid Measurements**

The analyzer has several encompassing facilities for hearing aid measurements: Harmonic, Intermodulation and Difference Frequency distortion as well as broadband RMS measurements. Output weighting can be used to compensate for the response of a sound source. Results can be functions of frequency, time or level as required for measurements of frequency responses, dynamic responses (for determination of attack and recovery times) and I/O responses respectively. Fig. 18 shows the basic set-up for these hearing aid measurements using the Anechoic Text Chamber Type 4222.

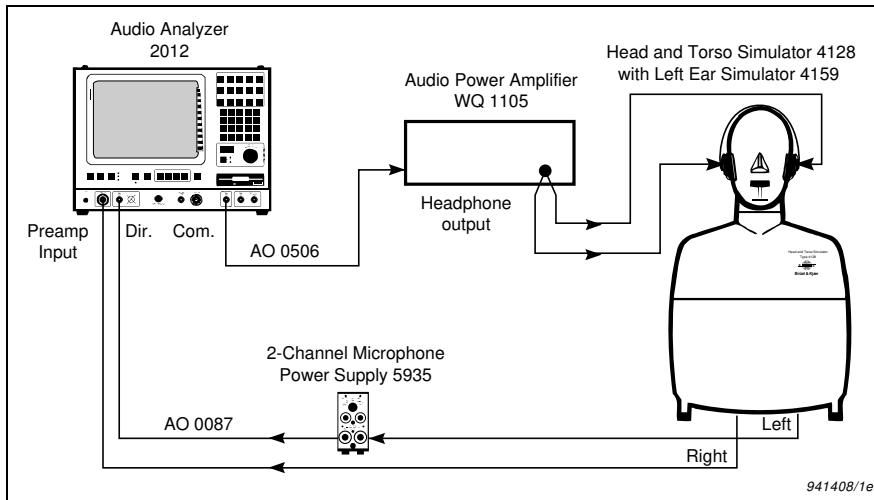

Fig. 19 Head and Torso Simulator Type 4128 can be used with Type 2012 for headphone measurements. Using 50W resistors, the two single outputs ( $f_1$  and  $f_2$ ) are summed, thereby enabling left- and right-channel measurements to be performed directly

**In Situ Measurements of Headphones, Headsets and Hearing Aids**

Using Head and Torso Simulator Type 4128 together with Type 2012 enables objective in-situ measurements of headphones, communication headsets and hearing aids. The setup in Fig. 19 can be used for automatic left- and right-channel frequency measurements of headphones. Type 2012 can also be used for free-field Insertion Gain measurements on hearing aids, i.e., measuring the difference between the frequency measured in the ear canal with a hearing aid fitted, and the open ear frequency response.

Application Disks with auto sequences cover advanced applications such as determination of loudspeaker parameters and the combination of near-field and far-field measurements obtained in an ordinary room into very accurate free-field responses using the post-processing facilities.

**Telephone Testing**

When used with the Telephone Interface Type 5906, Type 2012 forms a powerful telephone test system. The system illustrated in Fig. 17 can be used for measuring transmission characteristics of telephones, including free-field response of loudspeaker

telephones. Measurements of Receive, Send and Sidetone response as well as Return Loss, Noise and distortion can be measured. The FFT Spectrum mode can be used for measuring the ringer tone, DTMF (Dual Tone Multi Frequency) and for analyzing the switching characteristics of hands-free telephones.

Due to the unique measurement algorithms, most of these measurements can be made simultaneously with the presence of real speech signals. This may be required with telephone designs incorporating advanced speech detectors and signal processing.

**Input Characteristics:**

**DIRECT INPUT:**

Via BNT socket, single ended or balanced input (accepts BNC cables)

**Input impedance:** 1M $\Omega$ ||100pF

**Coupling:** AC

**Common mode voltage:** Max. 5V

Common mode rejection:

>70dB at 50/60Hz for  $\delta$  1V peak input range

>60dB at 50/60Hz for  $\delta$  1V peak input range

**Input ranges:** 33 ranges from 3mV to 100V peak in a 1, 1.5, 2, 3, 4, 6, 8 sequence

**PREAMP. INPUT:**

Via standard B&K 7-pin socket

**Input impedance:** 1M $\Omega$ ||100pF

**Polarization voltage:** 0 or 200V from 2M $\Omega$  source

**Heater Voltage:** +6V (at 200mA) from 30 $\Omega$  source and +12V (at 200mA) from <1 $\Omega$  source

**Input ranges:** 33 ranges from 3mV to 100V peak full scale in a 1, 1.5, 2, 3, 4, 6, 8 sequence

**MAXIMUM INPUT VOLTAGE:**

2012 is a safety class II instrument (IEC 348). For safe operation in accordance with IEC 348, the voltage of the signal ground relative to earth must not exceed 42V RMS (sine). To ensure safe operation in accordance with IEC 348 at higher voltages, the user must limit all input currents to 0.7mA peak  
 Maximum input voltage:  
 100V RMS/150V peak

**HIGH-PASS FILTERS:**

1Hz, -0.1dB. Slope 18dB/oct.

20Hz, -0.2dB. Slope 24dB/oct.

100Hz, -0.2dB. Slope 24dB/oct.

**ANTI\_ALIASING FILTER:**

**Cut-off frequency:** 40kHz. Provides at least 80dB attenuation of input frequencies which can cause aliasing. The filter can be bypassed in FFT mode

**INPUT SAMPLING:**

**Internal:** 102.4kHz

**A/D conversion:** 14 bit

**CALIBRATION:**

Units, dB reference and transducer sensitivity can be keyed into the Input menu. Automatic calibration with a known calibration source. The calibration values for the **Direct** and **Preamp** inputs are stored individually

**FREQUENCY RESPONSE:**

1Hz to 40kHz,  $\pm 0.1$ dB re 1kHz (with 1Hz high-pass filter)

**AMPLITUDE LINEARITY:**

$\pm 0.1$ dB or  $\pm 0.005\%$  of max. input, whichever is greater

**ATTENUATOR ACCURACY:**

$\pm 0.1$ dB

**HARMONIC AND SPURIOUS DISTORTION PRODUCTS:**

<-80dB re full scale in respective ranges for all attenuator settings

**INPUT AUTORANGE:**

Selects optimum attenuator setting. Can be switched on or off

**Output Characteristics:**

**SIGNAL GENERATOR TYPE:**

Two sine generators

**SEPARATE OUTPUT:**

Two BNT sockets on the front panel for the two separate output signals,  $f_1$  and  $f_2$  (accept BNC plugs)

**COMMON OUTPUT:**

One BNT socket on the front panel for the sum of the two output signals,  $f_1 + f_2$  (accepts BNC plugs)

**OUTPUT:**

Voltage:

$f_1$  and  $f_2$ : 100 $\mu$ V to 3.16V RMS in 0.1dB steps

$f_1 + f_2$ : 50 $\mu$ V to 1.58V RMS in 0.1dB steps

**Attenuator accuracy:**

$\pm 0.1$  dB

**Frequency Response:**

1Hz to 40kHz:  $\pm 0.1$ dB re 1kHz

**Harmonic and spurious distortion products:**

<-85dB at 3.16V and load >1k $\Omega$

**Inherent noise:**

<-95dB re 3.16V (1600Hz BW)

**Impedance:**  $f_1$ ,  $f_2$  and  $f_1 + f_2$ : 50 $\Omega$

**CALIBRATION:**

Units, dB reference and transducer sensitivity can be defined in the Output menu. Automatic calibration with an externally measured output signal in selected unit. Calibration values for  $f_1$  and  $f_2$  in both "Separate" and "Common" modes are stored individually

**Measurement Modes:**

Time Selective Response — TSR

Steady State Response — SSR

FFT Spectrum — FFT

Auto Sequence 1 to 5

**Time Selective Response:**

**RESPONSE:**

Relative response (transfer function) or absolute response (response signal only) can be measured.

**BASEBAND MODE:**

**Fundamental:** Frequency Range can be selected from 39 Hz to 40 kHz

**ZOOM MODE:**

**Fundamental:** Start and Stop Frequency can be selected from 1 Hz to 40 kHz

**Minimum Frequency Range:** 39 Hz

**Harmonic Distortion:** Up to 20th order harmonic distortion can be selected. For the nth order harmonic distortion Start and Stop Frequency can be selected from 20 Hz to (40/n) kHz

**TIME-WINDOW:**

50/(N $\times$ F), 100/(N $\times$ F), 200/(N $\times$ F),

400/(N $\times$ F) and 800/(N $\times$ F)

N = harmonic, F = frequency range

**DELAY:**

0.0s to 100.0s (max 5 decimals, rounded off to nearest 10 $\mu$ s value)

**SWEEP TIME:**

0.5, 1, 2, 4, 8, 16, 32, 64, 128, 256, 512s

**AVERAGES:**

1 to 4096

**PAUSE:**

0.0s to 100.0s

**CONDITIONING TONE:**

0.0s to 10.0s (max. 3 decimals, rounded off to nearest 10ms value)

**Steady State Response:**

**RESPONSE:**

Relative response (transfer function) or absolute response (response signal only) can be measured

**SWEEP:**

A sweep of the excitation frequency or the excitation level can be selected. A frequency sweep is set up by defining a start and a stop frequency and a number of steps which can be distributed on a logarithmic or linear scale or at user-defined values from 1 Hz to 40 kHz. A level sweep is set up by defining the excitation frequency, the output level range to be swept and the step size

**Log:**

$1/3$ ,  $1/6$ ,  $1/12$ ,  $1/24$ ,  $1/48$  and  $1/96$ -octave steps

**Log ISO:**

Series R 10, R 20, R 40 and R 80

**Lin:**

1 to 1600 steps

**User-defined:**

From 1 to 50 frequencies

**Output Level:**

Range and step size for an Output Level sweep can be selected from 0.1 dB to 80 dB

**DETECTOR:**

**Averaging:**

Averaging can be adaptive to estimate the response to a user-defined accuracy in the minimum possible time, or linear to average all data within a specified period of time. Complex or power averaging can be selected

**Detector band:**

0.01, 0.02, 0.03, 0.04, 0.05, 0.06, 0.08, 0.1, 0.15, 0.2, 0.3, 0.4, 0.5, 0.6, 0.8, 1.0, 1.5, 2, 3, and 6dB. The value specifies the required accuracy of the measurement (67% confidence level) when the adaptive scan algorithm is selected

**Detector delay:**

0ms, 10ms, 20ms, 50ms, 100ms, ... 10s. The value specifies the delay before the detector is activated for each excitation frequency

**Maximum detector time:**

0ms, 100ms, 200ms, 400ms, 800ms, 1.6s, 3.2s, 6.4s, 12.5s, ..., 13 ks. For adaptive averaging the value specifies the maximum measuring time after the detector algorithm has been activated. For linear averaging, the value specifies the averaging time

**HARMONIC DISTORTION:**

Simultaneous measurement of selected harmonics up to 20th. Total, Total Distortion and Total Harmonic Distortion can be automatically calculated from selected harmonics

**DIFFERENCE FREQUENCY DISTORTION:**

Simultaneous measurement of selected Difference Frequency products up to 9th order. Total Distortion can be automatically calculated from selected products

**INTERMODULATION DISTORTION:**

Simultaneous measurement of selected Intermodulation products up to 9th order. Total Distortion can be automatically calculated from selected products

**TOTAL RMS:**

Measurement of broadband RMS. Includes all distortion products and noise within the frequency range of the analyzer. Specifications for the dynamic range of the input are reduced for this type of measurement.

Distortion Products and Noise:

<-55dB re full scale

**FFT Spectrum:**

**BASEBAND MODE**

Freq.Range	Points	Samples	Time
1Hz-400Hz	1600	4096	4s
1Hz-400Hz	400	1024	1s
1Hz- 4kHz	1600	4096	400ms
1Hz- 4kHz	400	1024	100ms
1Hz-40kHz	1600	4096	40ms
1Hz-40kHz	400	1024	10ms

**ZOOM MODE**

Bandwidth	Points	Samples	Time
1.56Hz	513	1024	327.7s
3.12Hz	513	1024	163.8s
6.25Hz	513	1024	81.9s
.	.	.	.
.	.	.	.
.	.	.	.
1600Hz	513	1024	320ms

**Centre frequency:**

1Hz + B/2 to 40kHz - B/2

where B = bandwidth

**AVERAGING:**

Complex or Power averaging from 1 to 4096 averages

**WEIGHTING:**

Hanning, Flat Top or Rectangular by Power averaging

**GENERATOR:**

Off, one-tone and two-tone

**CONDITIONING TONE:**

(One-tone only)

Duration:

0.0s to 10.0s (max. 3 decimals, rounded off to nearest 10ms value)

Level:

-40dB to 40dB in 0.1dB steps, re measuring tone level

**TRIGGER:**

Free Run, External, Internal or Generator

**Trigger level:**

Can be selected in the range -100% to 100% of the specified input level, by internal trigger

**Trigger delay:**

**BASEBAND MODE**

Freq.Range	Time	Delay
1Hz-400Hz	4s	- 4s to 32s
1Hz-400Hz	1s	- 1s to 32s
1Hz- 4kHz	400ms	- 400ms to 3.2s
1Hz- 4kHz	100ms	- 100ms to 3.2s
1Hz-40kHz	40ms	- 40ms to 320ms
1Hz-40kHz	10ms	- 10ms to 320ms

**ZOOM MODE**

Freq.Range	Time	Delay
1.56Hz	327.7s	- 327.7s to 10485s
3.12Hz	163.8s	- 163.8s to 5242s
6.25Hz	81.9s	- 81.9s to 2621s
.	.	.
.	.	.
.	.	.
1600Hz	320ms	- 320ms to 10.2s

**External Trigger input:**

BNC socket on front panel

**External Trigger levels:**

HC MOS compatible. Triggers at high levels from 3.5 to 5.0V and does not trigger at low levels from 0 to 1.5V

**Manual Generator:**

Each generator can be activated for direct manual control of output and input.

The generators' output frequencies and levels are controlled by the dial on the front panel. The output frequency and level as well as the input level are shown on the screen

**Auto Sequences:**

2012 can store 5 Auto Sequences, each up to 100 lines.

Auto Sequences can be edited in a special menu appearing as a list containing the corresponding IEEE-488 bus commands. A "learn mode" is used to make this list by simply pushing the desired key. When an Auto Sequence is started, the functions and parameter settings are executed in sequential order

**Block Arithmetic:**

Block Arithmetic functions are performed on a set of data in one of the 11 result memories (Buffer, "M1" to "M10"). The result of a Block Arithmetic operation is a new set of data in the result Buffer, which can be copied to "M1" to "M10" at the same time

**OPERATIONS:**

- Copying data between the 11 result memories
- Weighting data with a frequency window: Hanning, Rectangular and Rectangular with Hanning-taper
- Weighting data with a time window: Hanning, Rectangular and Rectangular with Hanning-taper
- Addition and Subtraction
- Multiplication and Division (in the frequency domain)
- Time shift (linear phase shift in the frequency domain) of a set of data
- Change Sign (180° phase shift)
- Reciprocal Value (in the frequency domain)
- Absolute Value
- Square and Square root of the amplitude in the frequency domain
- Exp
- Ln (in the frequency domain)
- Constant (sets a set of data to a constant k)
- Adding poles/zeros
- Editing values
- Converting a set of data to another frequency format

**Special Calculation:**

For use with the software extension Special Calculation Software Type 7661 See separate Product Data sheet for further details.

**Disk I/O:**

Built-in 3 1/2" high-density floppy disk drive (720 Kbyte or 1.44Mbyte formatted capacity). The data format is compatible with PC/MS-DOS

A list of files can be shown on the screen.

Data which can be read from or to the disk is: parameter setups, Auto Sequences, sets of measurement data, screen pictures with measurement curves and user-defined text, screen copy data for printer or plotter

**OPERATIONS:**

- Store
- Recall
- Delete
- Protect
- Unprotect
- Rename
- Copy
- Format

**Internal Memory:**

A static 4 Mbyte RAM memory with battery back-up is used for storing:

- Program Source
- Parameter Setup
- 5 Auto Sequences
- 11 Measurement results (Buffer and "M1" to "M10")
- Dual Graph setup with up to 36 curves and two user-defined text buffers

When switching on or resetting the 2012 without the program disk, the program source, parameter setup, Auto Sequences, result memories and graph setups stored in the RAM are used. Switching on or resetting with the program disk in the disk drive reads the program source from the disk and reset all data to factory defaults

**Display:**

**Type:**

Built-in 12" CRT colour screen, 16 colours can be selected from a palette of 4096

**Resolution:**

640x480 points

**Frame frequency:**

50Hz or 60Hz

**Line frequency:**

31500Hz

**Contrast:**

Can be adjusted at the front panel

**RGB monitor:**

9-pin D-range female connector on the rear panel with RGB and sync signals

**Graph:**

The Graph menu on the screen is used to set up one or more (up to 36) curves in user-defined colours, based on the data from one of the 11 result memories. Curve colours, graph scaling, smoothing, grid setting and x- and y-axis parameters are also set up in this menu

**Functions implemented:**

- Frequency Response
- 1/3-octave Response
- Time Response
- Response Decay
- Frequency Spectrum
- 1/3-octave Spectrum
- Time Signal
- Signal Decay
- Auto Correlation
- Level Response

**Coordinate:**

Is used to select the real coordinate to be displayed from the complex function (if possible)

- Real Part
- Imaginary Part
- Magnitude
- Phase
- Group Delay
- Instantaneous Frequency

**SCALING FOR SPECTRA:**

Amplitude, RMS, power, ASD (amplitude spectral density), PSD (power spectral density) or ESD (energy spectral density)

**Screen Format:**

The default screen format has a graph area on the left-hand side of the screen and a menu on the right-hand side

The following screen formats can be set up in the Screen Format menu:

**Graph A:**

**Curve Only:** gives a single graph area for displaying up to 36 curves in user-defined colours  
**Text Only:** shows a full text page for keying in user-defined text

**Curve & Text:** for superimposed display of curves and text

**Graph B:**

As Graph A

**Graph A & B:**

Is used to display a dual screen format. The upper graph area shows the Graph A picture, the lower one Graph B.

**Graph Only:**

The Graph area (A, B or A & B) takes up the whole screen. No menu is shown

**Full TSR/SSR/FFT Setup:**

Parameters from Time Selective Response-, Steady State Response- or FFT Spectrum-menus respectively, as well as parameters from Level-, Input- and Output menus, are displayed in tables which take up the whole screen. No menu is shown

**Graph and TSR/SSR/FFT Setup:**

Parameters from Time Selective Response-, Steady State Response- or FFT Spectrum-menus respectively, as well as parameters from Level menus are displayed on the left-hand side of the screen. The graph area is shifted to the right. No menu is shown

**IEEE/IEC Interface:**

Conforms to IEEE-488.1 and IEC 625-1 standards. Any function shown on the display, except functions concerning IEEE-488 controller functions, can be transmitted to and from Type 2012. This includes parameter setup, result data, display data and Auto Sequences (in ASCII or binary format)

**FUNCTIONS IMPLEMENTED:**

- Source HandshakeSH1
- Acceptor HandshakeAH1
- TalkerT6
- ListenerL4
- Service RequestSR1
- Remote/LocalIRL1
- Parallel PolIPP1
- Device ClearDC1
- Device TriggerDT1
- ControllerC1, 2, 3, 4, 12

**COMMAND SET:**

Standard engineering English reflecting the front panel and screen names. Compound headers for read/write setup functions (refer to IEEE-488.2)

**CODE:**

ASCII (ISO 7-bit) code or binary

**INTERFACE TERMINATOR:**

Can be specified in the Interface IEEE menu or from a controller

**DEVICE ADDRESS:**

Addresses from 0 to 30 can be specified in the Interface IEEE menu

**CONTROLLER FUNCTIONS:**

Hard copies are output to the IEEE-488 bus only when Type 2012 is set up as system controller or is the controller-in-charge.

When 2012 is used as system controller it is possible to output interface messages:

- Universal Commands (DCL and LLO)
- Addressed Commands (SDC, GET and GTL)
- Listen Address and UNL
- Device Dependent Messages in ASCII code and to conduct a Serial Poll

**RS-232-C Interface:**

Screen Copy output only.  
 Conforms with the EIA Standard RS-232-C (equivalent to CCITT V24).  
 Coupled as a "Data Terminal Equipment" (DTE)  
 Connector: .....25-pin D-range male  
 Mode of operation: .....Full duplex  
 Number of data bits: .....7, 8  
 Number of stop bits: .....1, 2  
 Baud rates: .....300, 600, 1200, 2400, .....4800, 9600, 19200  
 Parity: .....None, Even, Odd  
 Synchronization method: X-on/X-off, Hardwired, Off

**Power Supply:**

**Voltage:** 100V, 115V, 127V, 200V, 220V and 240V AC ±10%  
**Frequency:** 50Hz–60Hz ±5%  
**Power rating:** approx. 150VA  
 Complies with Safety Class II of IEC 348

**General:**

**Safety:** Complies with IEC 348 Safety Class II  
**Cabinet:** Supplied as model A (metal cabinet) or C (as model A but with flanges for standard 19" racks)  
**Dimensions:**  
**Height:** 310.4mm (12.2in)  
**Width:** 430mm (16.9in)  
**Depth:** 400mm (15.7in)

**COMPLIANCE WITH STANDARDS:**

<b>CE</b>	CE-mark indicates compliance with: EMC Directive and Low Voltage Directive.
<b>Safety</b>	IEC 348: Safety requirements for electronic measuring apparatus.
<b>EMC Emission</b>	EN 50081–1: Generic emission standard. Residential, commercial and light industry. CISPR 22: Radio disturbance characteristics of information technology equipment. Class B Limits. FCC Rules, Part 15: Complies with the limits for a Class B digital device.
<b>EMC Immunity</b>	EN 50082–1: Generic immunity standard. Residential, commercial and light industry. <b>Note 1:</b> The above is guaranteed using accessories listed in this Product Data sheet only. <b>Note 2:</b> Rf immunity implies that specifications of harmonic and spurious when using the Direct- or the Preamp. input may be deteriorated by up to 40 dB in the most sensitive range. <b>Note 3:</b> ESD levels of +/- 8KV or higher, imposed on the keyboard connector when connected to the 2012, could cause malfunction of the keyboard. Proper function is established by disconnecting and connecting the keyboard.
<b>Temperature</b>	IEC 68–2–1 & IEC 68–2–2: Environmental Testing. Cold and Dry Heat. Operating Temperature: +5 to +40°C (+41 to +104°F) Storage Temperature: –25 to +70°C (–13 to +158°F)
<b>Humidity</b>	IEC 68–2–3: Damp Heat: Operating: 30°C, 90% RH (non-condensing) Storage: 40°C, 90% RH
<b>Mechanical</b>	Non-operating: IEC 68–2–6: Vibration: 0.3 mm, 20 m/s <sup>2</sup> , 10–500 Hz IEC 68–2–27: Shock: 1000 m/s <sup>2</sup>

**Weight:** 32.5kg (71.6lb)

**HELP PAGES:**

Help pages are provided for all buttons, and can be selected in English, German or French

**KEYBOARD:**

A standard "QWERTY" keyboard with exchangeable keys for German and French characters is delivered with the 2012. The 2012 is easily set up to German or French characters, at the same time changing the language of the help pages. The keyboard connects to the front panel

**SCREEN COPY:**

The Screen Copy function supports multi-colour pen-plotters (HPGL), matrix printers, ink-jet printers and laser printers can be connected to the IEEE-488 and RS-232-C outputs. By pushing the **Screen Copy** button a copy of the present screen picture is printed or plotted. Printer drivers for a number of popular printers are included in the instrument menu

**REMOTE CONTROL:**

8-pin DIN socket on the rear panel for controlling Start, Stop, Proceed or Continuous. One pin is used to indicate "Busy" state and one pin is used for user-defined indication controlled by push-keys

<p><b>TYPE OF CALIBRATION:</b></p> <p><b>EK 0130 Standard:</b> Certificate of Calibration and a complete test report with all measured data</p> <p><b>EK 0131 Pre-calibration:</b> Consists of two standard calibrations where the first calibration is performed on the analyzer as it is received. The second calibration is performed after adjustment/repair</p> <p><b>EK 0132 Initial:</b> Standard calibration ordered when a factory Certificate of Calibration is required with the delivery of a new analyzer</p>	<p><b>Tests Applied:</b> Visual inspection Digital Self-test Analog Self-test Frequency accuracy Output attenuator f1: 1 kHz and 40 kHz Output attenuator f2: 1 kHz and 40 kHz Output Frequency Response f1: Full scale and full scale minus 30 dB Output Frequency Response f2: Full scale and full scale minus 30 dB Common Output f1+f2, f1 Common Output f1+f2, f2 Input Frequency response Input attenuator: 1 kHz and 40 kHz Input amplitude linearity</p>	<p>Preamplifier input Polarization voltage (outside accreditation) <b>Certificate of Calibration:</b> Complete test report with all measured data and measurement uncertainties. All measurements are traceable to international standards. Calibration fulfils ISO 9000 requirements.</p>
--	--	--

## Ordering Information

<p><b>Type 2012:</b> Audio Analyzer Includes the following Accessories:</p> <p>Type 7661: Special Calculation Software. See separate section for description</p> <p>BA 1000: Binder containing User Manuals Vols. 1, 2 and 3, (in English), Main Program Disks (in English, French and German), Familiarization Guide Disk and Application Example Disks</p> <p>NP 0028: External Keyboard</p> <p>SN 0187: Set of keys with French characters</p> <p>SN 0188: Set of keys with German characters</p> <p>2×AO0087: BNC to BNC Coaxial Cables</p> <p>AO 0158: BNT to BNT Triaxial Cable</p> <p>JJ 0330: BNT Triaxial Connector</p> <p>JP 0315: BNT Triaxial Plug</p> <p>JP 0802: 8-pin DIN plug (male)</p> <p>2×VF0007: Spare Fuses F 1.6A/250V</p> <p>3×VF0019: Spare Fuses F 3.15A/250V Mains Cable</p> <hr/> <p><b>Optional Accessories</b></p> <p><b>KS 0027:</b> Set of Rack Mounting Flanges</p> <p><b>WB 1360:</b> Remote Controlled Switchbox</p> <p><b>Calibrations:</b></p> <p><b>EK 0130:</b> Standard</p> <p><b>EK 0131:</b> Pre-calibration</p> <p><b>EK 0132:</b> Initial (See separate specifications for full information)</p> <p><b>UA 1283:</b> Upgrade Kit Kit for upgrading Audio Analyzer Type 2012 Version 3.0 to Version 4.0</p>	<p>The kit includes the following items:</p> <ul style="list-style-type: none"> <li>• Main processor board with 4 Mbyte static RAM and battery back-up</li> <li>• PROM upgrade</li> <li>• Binder containing User Manuals Vol. 1, 2 and 3 (in English), Main Program Disks, Familiarization Guide Disk and Application Example Disks</li> </ul> <p>The upgrade kit can be installed at the nearest Brüel &amp; Kjær service office</p> <hr/> <p><b>System Configurations</b></p> <p><b>LOUDSPEAKER AND MICROPHONE TESTING:</b></p> <p><b>Type 2669 B:</b> Microphone Preamplifier</p> <p><b>Type 4191:</b> Free-field 1/2" Microphone</p> <p><b>AO 0428:</b> Preamplifier Cable</p> <p><b>WQ 1105:</b> Audio Power Amplifier</p> <p><b>AO 0027:</b> Microphone Extension Cable (3m)</p> <p><b>AO 0087:</b> BNC to BNC Cable</p> <p><b>UA 0801:</b> Tripod</p> <p><b>UA 0588:</b> 1/2" Microphone Support</p> <p><b>UA 0610:</b> Extension Rod</p> <p>Application Disks with Auto Sequences for Loudspeaker Parameter Measurements (using Laser Velocity Transducer Type 3544), Simulated Free-Field Loudspeaker Measurements and Microphone Measurements are available. These are described in separate Product Data sheets</p> <p><b>TELEPHONE TESTING:</b></p> <p><b>Type 5906:</b> Telephone Interface (includes IEEE-488 Interface Cable AO 0265)(National variations available)</p> <p><b>Type 4227:</b> Mouth Simulator</p> <p><b>Type 4602:</b> Telephone Test Head</p> <p><b>Type 4185:</b> Ear Simulator for Telephonometry (including 1/2" microphone and preamplifier and built-in sound source for seal check)</p>	<p><b>3×AO0087:</b> BNC to BNC Cable</p> <p><b>AO 0434:</b> Dual 4 mm plug cable</p> <p><b>JP 0225:</b> BNC socket to dual 4 mm plug</p> <p>PC-controlled test systems based on Type 2012 are available. These systems are described in separate Product Data sheet</p> <p><b>HEARING AID TESTING:</b></p> <p><b>Type 4222:</b> Anechoic Test Chamber</p> <p><b>Type 4157:</b> Ear Simulator</p> <p><b>Type 2669 B:</b> Microphone Preamplifier</p> <p><b>Type 4192:</b> 1/2" Condenser Microphone</p> <p><b>WQ 1105:</b> Audio Power Amplifier</p> <p><b>AO 0087:</b> BNC to BNC Cable</p> <p><b>HEADPHONE TESTING</b></p> <p><b>Type 4128:</b> Head and Torso Simulator</p> <p><b>Type 4159:</b> Left Ear Simulator</p> <p><b>Type 5935:</b> 2-channel Microphone Power Supply</p> <p><b>WQ 1105:</b> Audio Power Amplifier</p> <p><b>AO 0087:</b> BNC to BNC Cable</p> <p>An Application Disk with Auto Sequences for Headphone Measurements is available. It is described in separate Product Data sheets</p> <hr/> <p><b>Miscellaneous:</b></p> <p><b>QR 1102:</b> Package of 10 3 1/2" dual-sided double-density floppy disks</p> <p><b>QR 1105:</b> Package of 10 3 1/2" high-density floppy disks</p> <hr/> <p><b>Interface Cables:</b></p> <p><b>AO0265:</b> Interface Cable (2m), IEEE-488</p>
---	---	--

## Special Calculation Software — Type 7661

### USES:

- Automatic testing of telephones:
  - Handset telephones
  - Hands-free telephones
  - Loudspeaking telephones
  - DTMF testing
- Automatic testing of transducers and other audio equipment:
  - Loudspeaker drive units
  - Complete loudspeaker systems
- Automatic testing of hearing aids, headphones, microphones, hydrophones, head-sets and intercom systems
- Evaluation of automotive acoustics
- Preparation of report-ready documentation
- Calculation of Curve Summation, for example, weighted overall levels (Loudness Rating, CCITT Rec. P.79)
- Automatic testing against absolute, floating or aligned tolerance limits
- Reference cursor for reading out cursor values relative to a reference point or curve
- Cursor value conversion, for example for converting sound propagation delay into path length
- Max. or Min. Cursor for finding local or global maxima or minima. Calculation of pure tone frequency and level (spectrum), for example for DTMF testing. Calculation of resonance parameters (response), resonance frequency, Q-value or peak value
- Various mathematical and Boolean operations on the above
- All Special Calculation values can be integrated in the graph text and can be automatically updated when making new measurements

### FEATURES:

- Calculation of Curve Average, such as sensitivity (IEC 581-7) and Loudness Rating (IEEE-269/661)

Special Calculation Software Type 7661 is a software extension for the Audio Analyzer Type 2012. The main purpose of Type 7661 is to increase the analyzer's options for making automated measurements, and extracting and presenting information from the measurements.

Type 7661 is suitable for quality control purposes where the result of a measurement must be reduced to a passed/failed indication and where the analyzer must perform certain operations dependent on the result.

Type 7661 is equally suited for general measurement purposes where a measurement result must be expressed as a single number, or a few numbers.

The facilities of Type 7661 are contained in the Special Calculation menu. Access to this menu requires a special "key" which must be installed in the 2012.

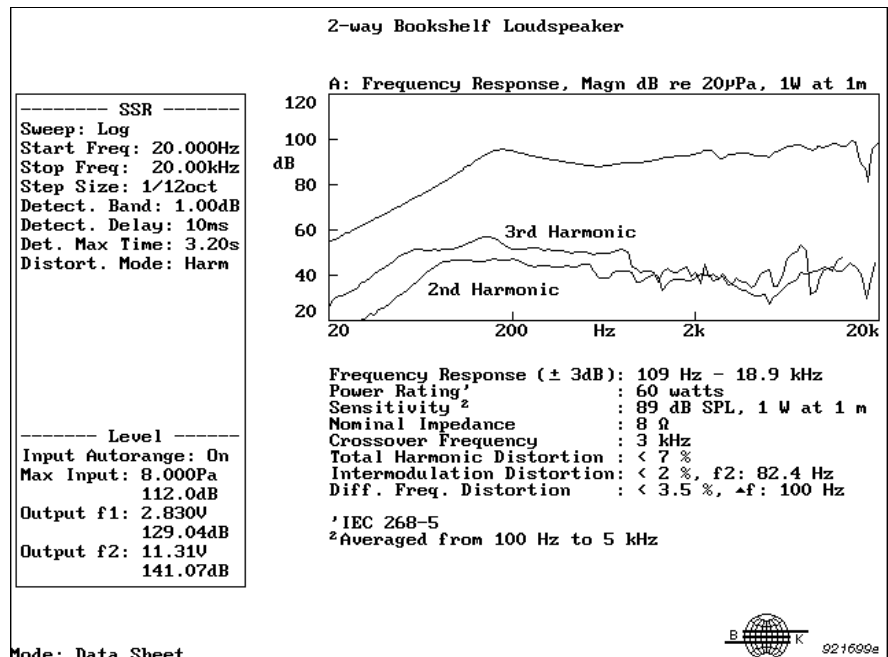

Fig.1 Report-ready documentation. 7661 has advanced facilities for integrating measurement values and graph text with measurement curves on the screen. You can set up any number of curve references in a graph text. Values are automatically updated when new values are measured or calculated. Data can be exported to a computer spreadsheet



Introduction

**Test and Design Parameters**

Measurement curves are invaluable for development purposes, but they usually contain a lot more information than is actually needed. For most practical purposes, the final result that is needed from a measurement is not a curve but a single value. This is particularly true for quality control purposes where a product such as a loudspeaker or a telephone, must pass certain quality criteria to decide whether or not the unit is rejected. The result of such a measurement must therefore be reduced to a passed/failed indication.

For a number of general measurements, it is also necessary to express a measurement as a single value. This is the case with measurements that comply with certain standards, e.g., Loudness Rating, Loudspeaker sensitivity or hearing aid gain (HFA).

For practical purposes, where the analyzer must perform certain operations automatically depending on the outcome of a measurement, it is also necessary to reduce a measurement to a single value.

**Report-ready Documentation**

Type 7661 enables the analyzer to calculate a single value and read it out in the Special Calculation cursor field. Up to ten single values (curve values) can be stored with each curve, and each curve value can consist of a name, a value, a unit and a test result. The curve values can be further processed by using mathematical operations, and they can be tested against tolerance limits. In addition, up to ten text strings can be stored with each curve. The text strings can be used for storing information about the operator, a serial number, the date and/or time of the measurement. Finally, the curve values and text strings can be integrated into a graph text, which is automatically updated when new measurements are made or new values are calculated. Report-ready documentation can then be printed or plotted out directly from the analyzer. Alternatively, an ASCII output can be produced for export to a computer spreadsheet.

**Curve Operations**

The curve operations Summation, Average and Tolerance are used to cal-

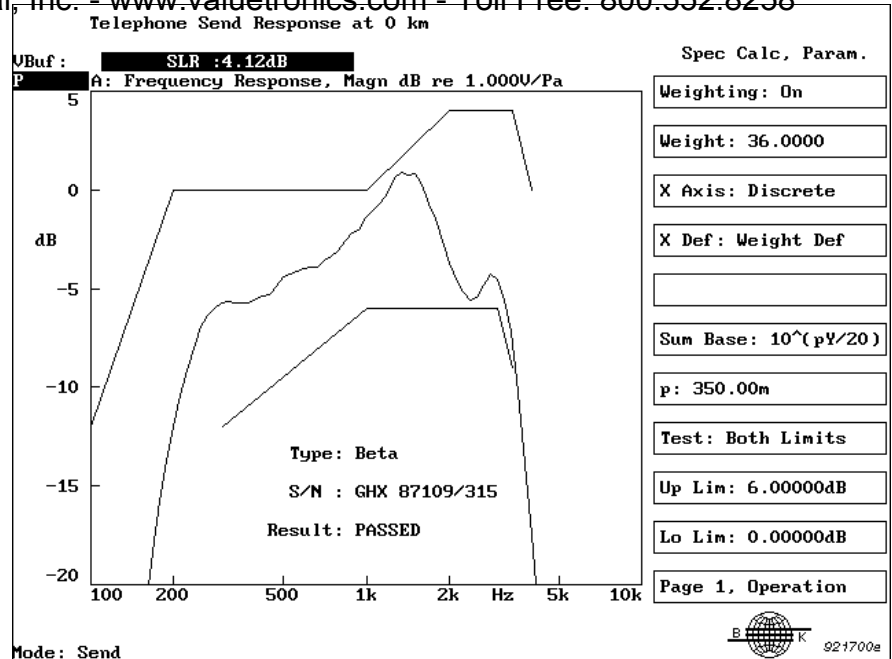

Fig.2 The Curve Summation facility can be used for calculating, for example, Loudness Rating for telephones. The curve as well as the calculated values can be tested against tolerance limits

culate a single value from a measurement curve.

You can store up to four different parameter set-ups for each of the curve operations. This means that you can easily change between, for example, Loudness Rating according to IEEE-269, IEEE-661 or CCITT Rec. P.79.

**Curve Summation**

This is used for calculating a weighted total sum of the values in the curve, for example Loudness Rating according to CCITT Rec. P.79. Fig.13 shows a telephone measurement with tolerance limits and Loudness Rating.

**Curve Average**

This is used for calculating a weighted average of the values in a curve, such as Loudness Rating according to IEEE-269/661, Loudspeaker Sensitivity according to IEC 581-7 or HFA gain (hearing aid gain) according to ANSI S3.22.

**Curve Tolerance**

Generates a Pass/Fail message and calculates the margin (the least distance) from a curve to one or two tolerance limits. The following types of tolerance limits are available:

- Absolute — the curve is tested against fixed tolerance limits
- Floating — the curve is positioned relative to the tolerance limits (or

vice versa) in such a way that the minimum distance from the curve to the upper and lower tolerance limits is exactly the same

- Aligned — the curve is positioned relative to the tolerance limits (or vice versa) by a specified offset at a user-defined reference point.

**Special Cursors**

The cursor operations Reference, Convert, Max. and Min. are used to calculate one or more curve values based on the current cursor position.

You can store up to four different parameter set-ups for each of the special cursors.

**Reference Cursor**

Can be used for reading out the difference between the actual cursor position and a reference value. The reference value can be another point on the same curve, or a point on another curve.

**Convert Cursor**

Calculates a linear, logarithmic, reciprocal or exponential conversion of the cursor coordinates. It can be used to read out the difference in distance between different signal paths, based on the delay and a specified propagation speed, or to read out distortion in percentage instead of dB.

**Max. and Min. Cursors**

For locating a local or global minimum or maximum and positioning the cursor on that point. Furthermore, for frequency responses, the resonance frequency, level and quality factor (Q) can be calculated. For frequency spectra the pure tone frequency and level can be calculated. Fig.3 illustrates a data sheet for a loudspeaker with some of the basic driver parameters.

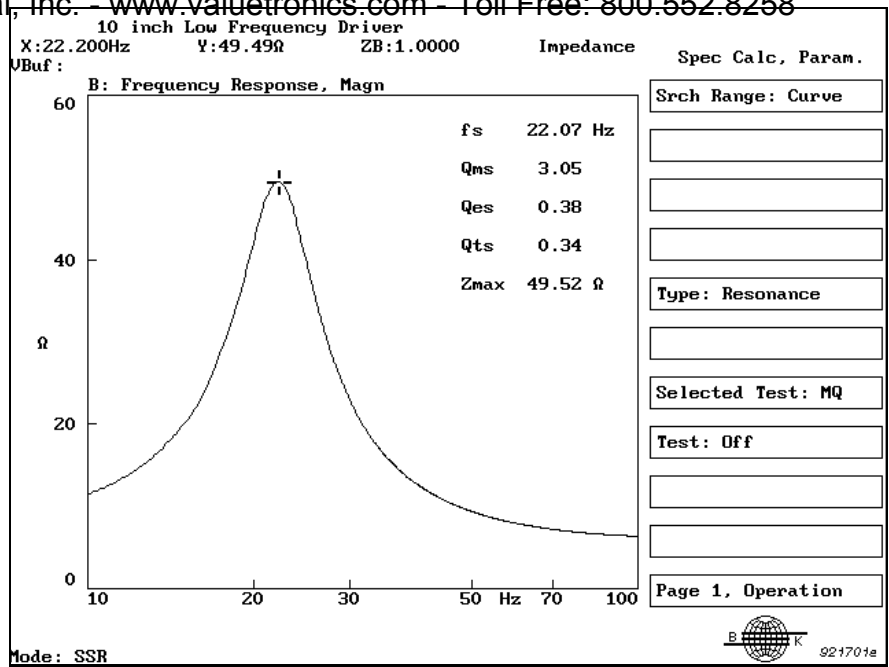

Fig.3 The Max. Cursor can be used to automatically calculate the Q-value for a loudspeaker

**Value Operations**

A number of mathematical operations can be performed on the curve values. The results can be tested against tolerance limits. The operations are:

- Addition
- Subtraction
- Multiplication
- Division
- Square
- Square root
- Sign Change
- Reciprocal
- Absolute
- Ln
- Logarithm
- Exponent
- 10^
- Maximum
- Minimum
- Test — for testing a value against a reference interval
- AND
- OR
- NOT
- Copy — for transferring values between different memories

**Tolerance Limits**

All curve values can be tested against both upper and lower limits and as a result will produce a passed or failed indication. The logical (Boolean) operators listed above are used for various operations on test results, e.g., if a test object must pass a number of tests before it is accepted, the “AND” operator can be used to check if all tests are passed.

**Edit Operations**

Various editing facilities are available for changing the name, numerical value, unit and passed/failed information of a test result. The current date and time from the 2012’s internal clock can also be stored with each curve.

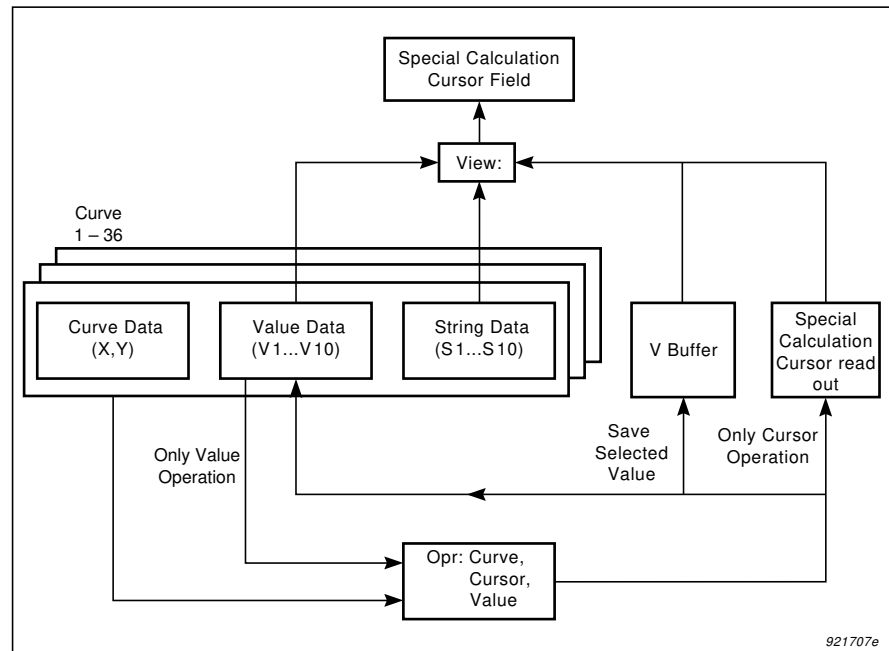

Fig.4 Overview of the data flow and the View function for reading out results for the curve operations, cursor operations and value operations

**Curve References**

This feature allows all curve values and text strings to be integrated into a graph text, anywhere in the screen picture. These are automatically updated if new values are measured or calculated.

**Installing 7661**

For maximum compatibility, there is only one version of the 2012 main program which includes the Type 7661. To make use of the facilities of Type 7661 which are contained in the Special Calculation menu, a hardware “key” must be installed in the 2012.

## Curve Operations

### CURVE SUMMATION:

For calculating a total sum of the values in a curve according to:

$$a' = \left( \sum_n B_n (W_n^p \times a_n^{|p|}) \right)^{1/p}$$

A weighting curve can be specified. The summation can be performed over all the values in the measurement curve, the weighting curve or in a specified interval. The values can be used directly or can be raised to any power. The calculated results can be tested against upper, lower or both limits.

### CURVE AVERAGE:

For calculating an average of the values in a curve according to:

$$a' = \left( \frac{\sum_n B_n (W_n^p \times a_n^{|p|})}{\sum_n B_n} \right)^{1/p}$$

Otherwise as described for Curve Summation.

### CURVE TOLERANCE:

For calculating the margin (the least distance) from a curve to one or two tolerance limits.

- **Absolute:** Both the curve and tolerance limits are fixed
- **Floating:** Makes a best fit for the curve between the tolerance limits
- **Aligned:** Positions the curve relative to the tolerance limits (or vice versa) by a specified offset at a user-defined reference point.

## Cursor Operations

### CURSOR REF:

Reads out the difference between a reference and the current cursor position. Both X-Y- or Z-values are read out.

### CURSOR CONVERT:

Calculates and reads out a linear, logarithmic, reciprocal or exponential conversion of the cursor coordinates. X, Y or Z-values can be converted.

### CURSOR MAX:

Finds a local or global maximum for a curve and positions the cursor on that point. The maximum can be found within a specified absolute interval, or within a standardized octave interval. From the magnitude of a frequency response, the resonance frequency, the level and the quality factor (Q) can be calculated. From the magnitude of a frequency spectrum, the pure tone frequency and level can be calculated.

### CURSOR MIN:

Finds a local or global minimum for a curve and positions the cursor on that point. The minimum can be found within a specified absolute interval, or within a standardized octave interval. For magnitude of a frequency response, the resonance frequency, the level and the quality factor (Q) can be calculated.

All calculated cursor values can be tested against upper and/or lower limits.

## Value Operations

The following mathematical operations can be performed on curve values:

- Addition
- Subtraction
- Multiplication
- Division
- Square
- Square root
- Sign Change
- Reciprocal
- Absolute
- Ln
- Logarithm
- Exponent
- 10<sup>^</sup>
- Maximum

- Minimum
- Test
- AND
- OR
- NOT
- Copy

The Boolean operators can only be used with the test results (passed/failed). "Passed" is represented by "true" and "failed" by "false". Test is used for testing a value against a reference interval. Copy is used for transferring values between different memories.

### EDIT FACILITIES:

For editing the name, numerical value, unit and test result of a curve value. Text strings can also be edited.

## Storage

Up to ten curve values consisting of a name, numerical value, unit and test result can be stored with each curve. All results are temporarily stored in a Special Calculation Buffer called "Vbuffer" and can be stored in the curve value memories "V1, ..., V10".

Up to ten text strings can be stored with each curve. Text strings are stored in memories S1, ..., S10, and each text string can consist of maximum 12 characters. The date and time can be transferred from the 2012's internal clock to a text string.

Four different parameter set-ups can be stored for each of the curve operations and each of the special cursors.

## Curve References

Any number of curve values and text strings can be integrated in a graph text. The curve reference values are automatically updated if new values are measured or calculated.

For full specifications of Type 2012, see the separate Product Data BP 0995 and BP 1302.

## Ordering Information

Ordering of Type 2012 includes the Type 7661 Software. Type 2012A versions 3 and 4 can be upgraded to Type 2012 by ordering and installing Type 7661

The Type 7661 software is supplied on the same 3 1/2" 1.44Mbyte disk as the main program. The user information is included in the Manuals supplied with the analyzer. When you order Type 7661 you receive a Protection Key VP 5348 and

an Installation Guide BI0774 that tells you how to install the Protection Key in the 2012 Analyzer. If you encounter any problems you should contact your local Brüel&Kjær representative.

Brüel&Kjær reserves the right to change specifications and accessories without notice



WORLD HEADQUARTERS: DK-2850 Nærum • Denmark • Telephone: +4542800500 • Telex: 37316 bruka dk • Fax: +4542801405 • e-mail: [info@bk.dk](mailto:info@bk.dk)