

BOONTON

Control # - 100117 Control Date - 3/3/99
Mfg - BOONTON
Model/Series - 8210
Document Type - Instruction Manual
Note - FM-AM Modulation Meter

4.4.85

INSTRUCTION MANUAL
MODEL 8210
F.M.-A.M. MODULATION METER

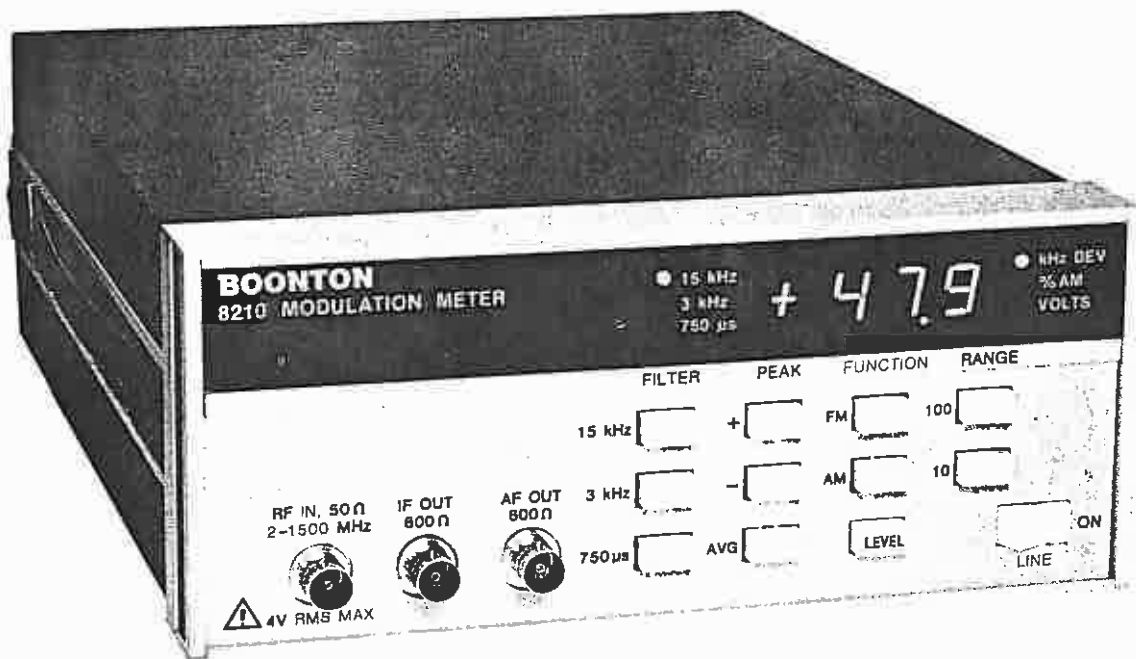

Figure 1-1. Model 8210 F.M.-A.M. Modulation Meter

TABLE OF CONTENTS

SECTION I - INTRODUCTION

SUBSECTION	PAGE
1-1 Safety Notice.....	1-1
1-2 Description of the Instrument.....	1-2
1-3 Items Furnished.....	1-2
1-4 Options and Accessories.....	1-2
1-5 Environmental Data.....	1-2
1-6 Specifications.....	1-2

SECTION II - INSTALLATION AND OPERATION

2-1 Installation.....	2-1
2-2 Operating Controls, Indicators and Connectors.....	2-2
2-3 Preliminary Check.....	2-4
2-4 Application Notes.....	2-4
2-5 Operating Instructions.....	2-8
2-6 Performance Verification.....	2-9
a. Test Equipment Required.....	2-9
b. R.F. Input Sensitivity.....	2-10
c. Deviation Accuracy.....	2-10
d. Residual F.M.	2-11
e. Residual A.M.	2-11
f. A.M. Rejection.....	2-12
g. A.M. Audio Distortion.....	2-12
h. Audio-Frequency Response, 15 kHz.....	2-12
i. F.M. Audio Distortion.....	2-13
j. F.M. Rejection.....	2-13
k. Audio-Frequency Response, 3 kHz.....	2-14
l. Audio-Frequency Response, 750 μ s De-emphasis.....	2-14
m. A.M. Depth Accuracy.....	2-14

SECTION III - THEORY OF OPERATION

3-1 Introduction.....	3-1
3-2 Circuits: General Discussion.....	3-1
a. R.F. Circuits.....	3-1
b. I.F. Circuits.....	3-2
c. Calibrator Circuits.....	3-2
d. A.F. Circuits.....	3-2
e. Logic Circuits.....	3-2
f. Power-Supply Circuits.....	3-2
3-3 Circuits: Detailed Discussion.....	3-2
a. R.F. Circuits.....	3-2
b. I.F. Circuits.....	3-5
c. Calibrator Circuits.....	3-7
d. A.F. Circuits.....	3-10
e. Logic Circuits.....	3-10
f. Power-Supply Circuits.....	3-13

SECTION IV - MAINTENANCE AND ADJUSTMENT

SUBSECTION	PAGE
4-1	Introduction.....4-1
4-2	Test Equipment Required.....4-1
4-3	Location of Major Assemblies.....4-1
4-4	Removal of Major Assemblies and Parts.....4-1
a.	Instrument Covers.....4-1
b.	R.F.-Assembly Cover.....4-4
c.	R.F. Circuit Board.....4-4
d.	I.F.-A.F. Circuit Board.....4-4
e.	Rear-Panel Assembly.....4-4
f.	Digital Circuits and Power-Supply Board.....4-5
g.	Display Circuit Board.....4-5
4-5	Removal of Detail Parts.....4-5
4-6	Preliminary Checks.....4-6
4-7	Troubleshooting.....4-7
4-8	Adjustment and Alignment Procedures.....4-26

SECTION V - PARTS LIST

5-1	Introduction.....5-1
-----	----------------------

SECTION VI - SCHEMATIC DIAGRAMS

6-1	Schematic Diagrams, Table of Contents.....6-1
-----	---

APPENDIX A - CALIBRATOR OPERATION

A-1	Introduction.....A-1
A-2	Technical Discussion.....A-1
a.	F.M. Calibrator.....A-1
b.	A.M. Calibrator.....A-1
c.	Audio Processing.....A-4
d.	R.F. Circuitry.....A-4

LIST OF ILLUSTRATIONS

FIGURE	PAGE
1-1	Model 8210.....ii
2-1	Model 8210, Front View.....2-3
2-2	Model 8210, Rear View.....2-3
2-3	Residual F.M., Typical.....2-5
2-4	Residual A.M., Typical.....2-5
2-5	Audio Response, Typical.....2-6
2-6	Test Setup: R.F. Input Sensitivity.....2-10

LIST OF ILLUSTRATIONS (CONTINUED)

FIGURE	PAGE
2-7	Test Setup: Residual F.M., Residual A.M.2-11
2-8	Test Setup: A.M. Rejection, Frequency Response, Audio Distortion.2-12
2-9	Test Setup: F.M. Audio Distortion, F.M. Rejection.....2-13
2-10	Packaging Diagram.....2-14
3-1	Simplified Block Diagram.....3-1
3-2	R.F. Circuits: Detailed Block Diagram.....3-3
3-3	Sampling Gate: Simplified Operation.....3-4
3-4	I.F. Circuits: Detailed Block Diagram.....3-6
3-5	Calibrator Circuits: Detailed Block Diagram.....3-8
3-6	A.F. Circuits: Detailed Block Diagram.....3-9
3-7	Logic Circuits: Detailed Block Diagram.....3-11
3-8	Program Flow Diagram.....3-12
4-1	Model 8210: Top View with Covers Removed.....4-2
4-2	Model 8210: Bottom View with Covers Removed.....4-3
4-3	Test Setup: Adjustment and Alignment.....4-27

LIST OF TABLES

TABLE	PAGE
2-1	Operating Controls, Indicators and Connectors.....2-2
2-2	Test Equipment for Performance Verification.....2-9
4-1	Test Equipment for Maintenance and Adjustment.....4-1
4-2	Power-Supply Checks.....4-6
4-3	Condition-Code Displays.....4-8
4-4	Troubleshooting Test-Switch Chart.....4-8
4-5	Symptomatic Troubleshooting Chart.....4-9
4-6	Systematic Troubleshooting Chart: R.F. Circuits.....4-10
4-7	Systematic Troubleshooting Chart: I.F. Circuits.....4-14
4-8	Systematic Troubleshooting Chart: A.F. Circuits.....4-16
4-9	Systematic Troubleshooting Chart: Logic Circuits.....4-20
4-9a	Signature-Analysis Chart: Address Field.....4-23
4-9b	Signature-Analysis Chart: Decoder Circuit.....4-24
4-9c	Signature-Analysis Chart: PROM's A4U11 and A4U13.....4-24
4-10	Systematic Troubleshooting Chart: Calibrator Circuits.....4-25
4-11	Systematic Troubleshooting Chart: Power Supply.....4-26
5-1	Manufacturers' Code Numbers.....5-1
5-2	Replaceable Parts.....5-2

WARRANTY: Cover 3

SECTION I

GENERAL INFORMATION

1-1. SAFETY NOTICE

The Model 8210 is furnished with a three-conductor power cable and three-prong plug so that, when the plug is inserted in a properly polarized a.c. power receptacle, the instrument is grounded. The instrument depends upon such connection to ground for equipment and operator safety.

*** WARNING ***

To avoid the possibility of electrical shock, before anything is connected to this instrument, and before you use this instrument, make certain that its power cable is plugged into a mating a.c. receptacle that has a grounded ("earthed") contact.

Never defeat the instrument's protective grounding. For example: Do not use an extension power cable if it is not equipped with a ground conductor; do not plug the instrument into an a.c. receptacle that does not provide a high-quality earth ground. If only a two-terminal a.c. power receptacle is available, use a three-prong-to-two-prong adapter and connect the ground wire of the adapter to the power-receptacle ground. Do not use such an adapter if the ground wire cannot be grounded.

1-2. DESCRIPTION

The Model 8210 Modulation Meter, manufactured by Boonton Electronics Corp., is a versatile, solid-state instrument that measures and displays the deviation of frequency-modulated signals or the percentage modulation of amplitude-modulated signals over a carrier range of 2 MHz to 1.5 GHz. Both the a.m. and f.m. detectors of the 8210 are true peak-responding at all levels. Thus they conform to the basic definition of modulation depth or deviation. In addition, because the detectors are true peak-responding, the effect of any system noise will be accurately included in the measured value. Among the features of the Model 8210 are:

a. Fully Automatic Tuning and Leveling. The Model 8210 will automatically acquire the largest signal present at the input connector and adjust its local oscillator, and the gain of its measurement channel, to provide a fully calibrated display of amplitude modulation or frequency modulation.

b. Internal Calibration. Each time it is turned on, the 8210 calibrates both its a.m. and its f.m. detector.

c. Digital Display. The 8210 presents recovered modulation on a 3-1/2 digit display, providing exceptional resolution and accuracy for modulation measurements.

d. Pushbutton Operation. Selection of all operational parameters is made by means of pushbuttons, thus allowing fast measurement setup.

e. Low Residual Modulation. The 8210's exceptionally low residual modulation permits accurate measurements of low-noise sources. Direct residual measurements are possible if an external r.m.s. detector is used.

The Model 8210 is intended for both laboratory and field application. It will also be especially useful in the design of, and for production-line and field-testing of, f.m. and a.m. transmitters and signal generators.

1-3. ITEMS FURNISHED

The instrument is supplied complete with power cord. For making measurements the connection of various cables will be called for, depending upon the operating mode of the 8210. Required cable connections are discussed in paragraph 2.1d.

1-4. OPTIONS AND ACCESSORIES

Option -01: With this option, the 15 kHz low-pass filter is replaced by a 30 kHz low-pass filter. See Specifications, below, for details.

Accessory 950027: This is a rack-mounting kit (not supplied as standard), for mounting a single 8210 to left or right of center.

1-5. ENVIRONMENTAL DATA, OPERATING AND STORAGE

Temperature: Operating, 0 to +55°C
Storage, -55°C to +75°C

1-6. SPECIFICATIONS

R.F. INPUT:

Carrier-Frequency Range	2 MHz to 1.5 GHz
Tuning	Automatic
Sensitivity	10 mV, r.m.s., 2 MHz to 520 MHz 30 mV, r.m.s., 520 MHz to 1.5 GHz
Level Set	Automatic for levels up to 1 V
Maximum Safe Input	7 V, r.m.s.
Input Impedance	50 ohms, nominal

FREQUENCY MODULATION:

Maximum Deviation	150 kHz, peak
Deviation Ranges	10 and 100 kHz, full scale
Deviation Accuracy	1% of reading for modulation frequencies between 50 Hz and 5 kHz. 2% of reading, 5 kHz to 7.5 kHz.

NOTE: Peak residuals must be accounted for to obtain the above accuracies.

Modulation Bandwidth	<30 Hz to 15 kHz
Residual F.M. (R.F. Level >100 mV)	With 3 kHz low-pass filter: <150 Hz, r.m.s., at 1.5 GHz, decreasing linearly to a floor of <5 Hz, r.m.s. With 15 kHz low-pass filter: <200 Hz, r.m.s., at 1.5 GHz, decreasing linearly to a floor of <15 Hz, r.m.s.
A.M. Rejection	<100 Hz deviation at 50% a.m. (modulation frequency < 1 kHz) 3 kHz low-pass filter.

S1-6, Continued.

AMPLITUDE MODULATION

Modulation-Depth Ranges 10% and 100%, full scale

Depth Accuracy	Modulation Frequency	Accuracy	
		10% to 90% A.M.	<10% & >90% A.M.
	50 Hz to 5 kHz	1% of reading	3% of reading
	5 kHz to 7.5 kHz	2% of reading	6% of reading

NOTE: Peak residuals must be accounted for to obtain the above accuracies. Carrier frequency <520 MHz; r.f. level between -10 and +10 dBm.

Modulation Bandwidth <30 Hz to 15 kHz.

Residual A.M. With 3 kHz low-pass filter:
Less than 0.15% a.m., r.m.s., for input levels above 100 mV, r.m.s.

With 15 kHz low-pass filter:
Less than 0.25% a.m., r.m.s., for input levels above 100 mV, r.m.s.

NOTE: Carrier frequency <520 MHz; above 520 MHz residuals increase linearly with frequency.

F.M. Rejection Less than 1.0% a.m., peak, at 100 kHz peak modulation.

AUDIO-FREQUENCY RESPONSE

Filters 3 kHz low-pass, 15 kHz low-pass, & 750 μ s de-emphasis; corner accuracy is \pm 4%. Jumper selects de-emphasis either before or after the display.

Audio Distortion Less than 0.25% t.h.d., for 75 kHz peak deviation. <0.5% t.h.d., for 90% a.m.

Output Level F.M.: 1 V, r.m.s., approx., into 600 ohms at 1000 counts on the display.

A.M.: 1 V to 1.2 V, r.m.s.

DISPLAY

Modulation LED display; 1000 counts plus 50% over-range; true peak, positive peak, negative peak, or peak-average indications.

Annunciators Display of settings of mode switch and of filter. Digital display indicates level-high, level-low and unlocked conditions.

I.F. OUTPUT

Frequency 400 kHz, nominal.

Level 300 to 360 mV, approx., into 600 ohm load

POWER REQUIREMENTS

100, 120, 220, or 240 volts, a.c., 50 to 400 Hz; 24 VA.

S1-6, Continued.

DIMENSIONS 103 mm high x 218 wide x 278 deep
(4.1 in. x 8.6 x 11.0)

WEIGHT 3.18 kg (7.0 lbs.), approximately.

OPTIONAL MODEL 8210-01

This model is the same as the standard Model 8210 except as follows:

AUDIO-FREQUENCY RESPONSE

Filters The 15 kHz low-pass filter is replaced by a 30 kHz low-pass filter; corner accuracy is $\pm 4\%$.

FREQUENCY MODULATION

Deviation Accuracy 1% of reading for modulation frequencies between 50 Hz and 10 kHz.

2% of reading, 10 kHz to 15 kHz.

Modulation Bandwidth <30 Hz to 30 kHz

Residual F.M.
(R.F. Level >100 mV) With 30 kHz low-pass filter:
<400 Hz, r.m.s., at 1.5 GHz, decreasing linearly to a floor of <25 Hz, r.m.s.

With 3 kHz low-pass filter:
<150 Hz, r.m.s., at 1.5 GHz, decreasing linearly to a floor of <5 Hz, r.m.s.

AMPLITUDE MODULATION

Depth Accuracy	Modulation Frequency	Accuracy	
		10% to 90% A.M.	<10% & >90% A.M.
	50 Hz to 10 kHz	1% of reading	3% of reading
	10 kHz to 15 kHz	2% of reading	6% of reading

NOTE: Peak residuals must be accounted for to obtain the above accuracies.

Carrier frequency <520 MHz; r.f. level between -10 and +10 dBm.

Modulation Bandwidth <30 Hz to 30 kHz.

Residual A.M. With 30 kHz low-pass filter:
Less than 0.35% a.m., r.m.s., for input levels above 100 mV, r.m.s.

With 3 kHz low-pass filter:
Less than 0.15% a.m., r.m.s., for input levels above 100 mV, r.m.s.

NOTE: Carrier frequency <520 MHz; above 520 MHz residuals increase linearly with frequency.

SECTION II

INSTALLATION & OPERATION

2-1. INSTALLATION

a. Unpacking. The 8210 is shipped complete and ready for use. Unpack the equipment from the shipping container and inspect it for any damage that may have occurred during shipment. Check that all connectors and switches operate without binding.

NOTE: Save the packing material and container for possible use in reshipment of the 8210. See Figure 2-10 (p. 2-14) for the repacking method.

b. Mounting. For bench mounting, choose a clean, sturdy and uncluttered mounting surface. For rack mounting, an accessory package (Model Number 950027) is available; it consists of two angle-mounting brackets, two flat plates, four binder-head screws, and four lockwashers. To rack mount an 8210, proceed as follows:

- (1) The 8210 has one extrusion at each end of the front panel. On the outside surfaces of these extrusions, where they join the cabinet, are two strips of green pressure-sensitive tape. Remove or perforate these tape strips to expose the tapped mounting holes for the rack-mounting brackets.
- (2) Refer to the drawing in the accessory's package for the proper orientation of the two mounting brackets.
- (3) Mount the 8210 in the rack with standard rack-mounting screws through the slotted holes in the angle brackets.

NOTE: If necessary, the feet and tilt bail may be removed from the cover in order to clear any adjacent rack-mounted units.

c. Power Requirements. The 8210 can be operated on a.c. power sources of 100, 120, 220 or 240 volts, 50 to 400 Hz, single phase. The power required is 24 VA at 120 or 240 volts, a.c.

CAUTION

Before connecting the 8210 to an a.c. power source, see that the voltage-selector switches on the rear panel are set for the available line voltage and that a fuse of the proper rating is in the instrument's fuse holder: 0.25 A for 100 or 120 V; 0.125 A for 220 or 240 V -- either fuse to be type MDL Slo-Blo.

d. Cable Connections. Depending on the operating mode of the 8210, various cables will have to be connected to it; these cables are not supplied with the instrument. Connections that may be required are:

- (1) R.F. Input. The RF IN connector of the 8210 is a type BNC. The input impedance is 50 ohms, nominal.
- (2) I.F. Output. The 8210's i.f. output is available at the front-panel BNC marked IF OUT. The level varies between 300 and 360 mV, r.m.s.; the source impedance is 600 ohms, nominal.
- (3) A.F. Output. The recovered audio signal appears at the front-panel BNC connector labeled AF OUT. For f.m., the level is approximately 1 volt, r.m.s., into 600 ohms at 1000 counts on the digital display. For a.m., the level is 1 to 1.2 volts.

2-2. OPERATING CONTROLS, INDICATORS AND CONNECTORS

All controls, indicators and connectors used during operation of the 8210 are shown in Figures 2-1 and 2-2. They are described in Table 2-1, below.

Table 2-1. Operating Controls, Indicators, and Connectors

ITEM	FIGURE	INDEX NO.	FUNCTION
FILTER switches	2-1	1	Select low-pass or de-emphasis filters.
PEAK switches	"	2	Select display of + peak, - peak or peak average.
FUNCTION switches	"	3	Select AM, FM or LEVEL display functions.
RANGE switches	"	4	Select desired full-scale modulation range.
LED display	"	5	Indicates modulation or i.f. level--as determined by the FUNCTION switch setting.
LINE switch	"	6	Turns line power on and off.
RF IN connector	"	7	Input signal connection point.
IF OUT connector	"	8	Allows connection of 8210's i.f. signal to external circuits.
AF OUT connector	"	9	Allows connection of 8210's recovered audio signal to external circuits.
Power connector	2-2	1	Input connector for a.c. power cable.
Line-voltage switches	"	2	Permit selection of appropriate a.c. operating voltage.
Fuse holder	"	3	Contains replaceable line fuse.

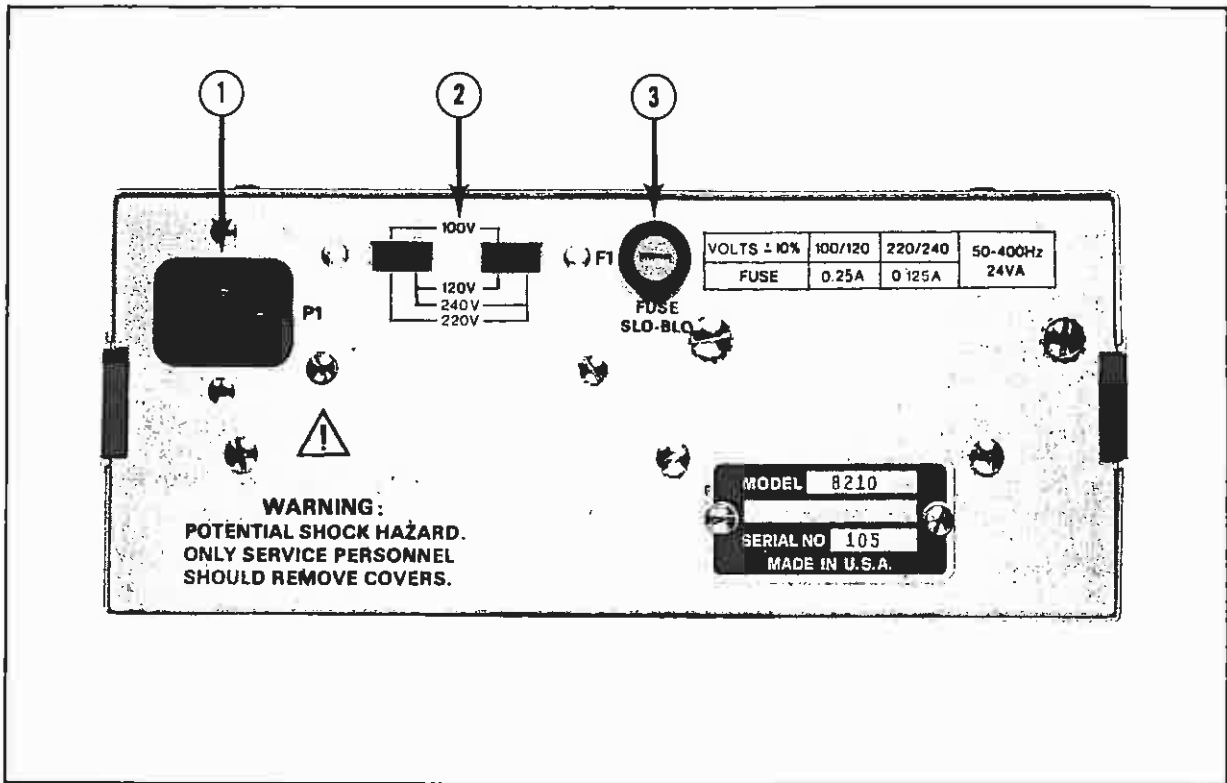

Figure 2-1. Model 8210, Front View

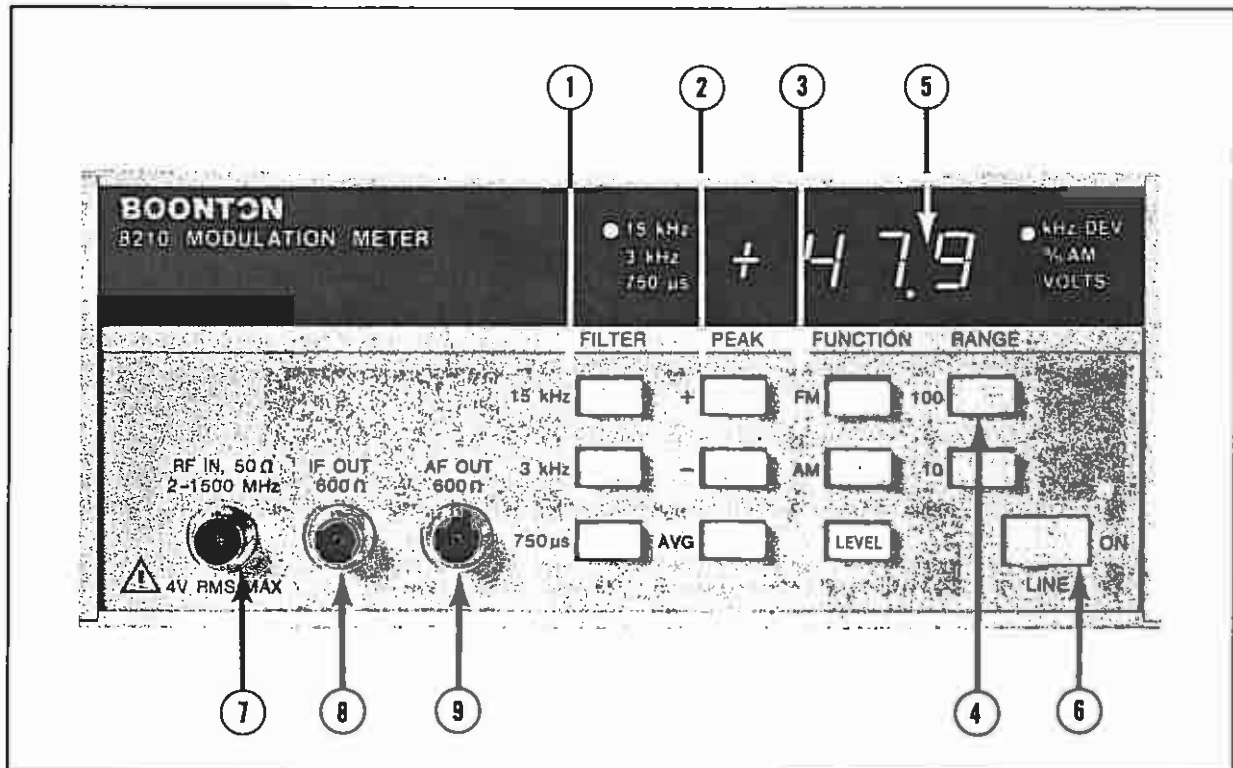

Figure 2-2. Model 8210, Rear View

2-3. PRELIMINARY CHECK

NOTE: The following preliminary check procedure is intended only to ensure that all circuits are operating. If a detailed performance check against specifications is desired, refer to subsection 2-6.

Before using the Model 8210, perform a preliminary check as follows:

- a. Set the LINE switch to the "on" position. The LED display should indicate "CAL," which means that the calibration sequence has begun. After about 30 seconds, a series of dashes should appear on the LED display, indicating an unlocked condition.
- b. Apply a 100 mV (r.m.s.) unmodulated test signal, at a frequency between 2 and 520 MHz, to the RF IN connector of the 8210. The LED display on the 8210 should now indicate residual modulation. Note that two dashes on the LED indicate that the 8210 is executing an a.g.c. cycle.
- c. Reduce the test signal to 5 mV. The display should indicate "IFLO."
- d. Increase the test signal to 1.5 V. The display now should read "IFHI."
- e. Decrease the test signal to approximately 0 dBm. The display should read as in Step (b).
- f. In turn, depress the three FILTER switches, and see that the associated annunciators indicate the switch selection correctly.
- g. Repeat Step (f) for the FUNCTION switches.
- h. Depress in turn the three PEAK switches. A plus sign (+) will be shown for the + PEAK switch, a minus sign (-) for the - PEAK, and no sign when the AVG switch is depressed.
- i. Depress in turn the RANGE switches. The decimal-point indication of the display should move to left or right as each switch is depressed.
- j. Connect an oscilloscope to the 8210's IF OUT connector. Set the 'scope so that it displays the 400 kHz i.f. signal of the 8210.
- k. Modulate the test signal with approximately 50% a.m. Depress the AM FUNCTION switch, the 100 RANGE switch, and the 15 kHz FILTER switch. The display should indicate approximately 50% a.m.
- l. Remove the amplitude modulation, and frequency-modulate the test signal with approximately 50 kHz peak deviation. Depress the FM FUNCTION switch. The display should indicate approximately 50 kHz deviation.

2-4. APPLICATION NOTES

The following paragraphs describe some typical applications for the Model 8210. The use of the 8210 is not restricted to these applications, however.

a. F.M. Measurements. High-accuracy f.m. measurements are possible with the 8210, for modulating frequencies from less than 30 Hz to 15 kHz, and deviations up to 300 kHz p-p. To achieve maximum accuracy, the signal level applied to the RF IN connector should be greater than 100 mV, r.m.s. Such signal levels reduce residual f.m. in the 8210 to a minimum value. To further reduce residuals, the minimum measurement-bandwidth consistent with the modulation frequency should be used. For instance: for measurements at a 400 Hz modulation rate, the 3 kHz low-pass filter should be used.

Typical residuals for the 8210 are plotted in Figures 2-3 and 2-4; audio response curves are plotted in Figure 2-5. Because the audio detectors in the 8210 are true peak-responding, the residual noise is added to the recovered signal being measured. Peak-detector response to a signal plus

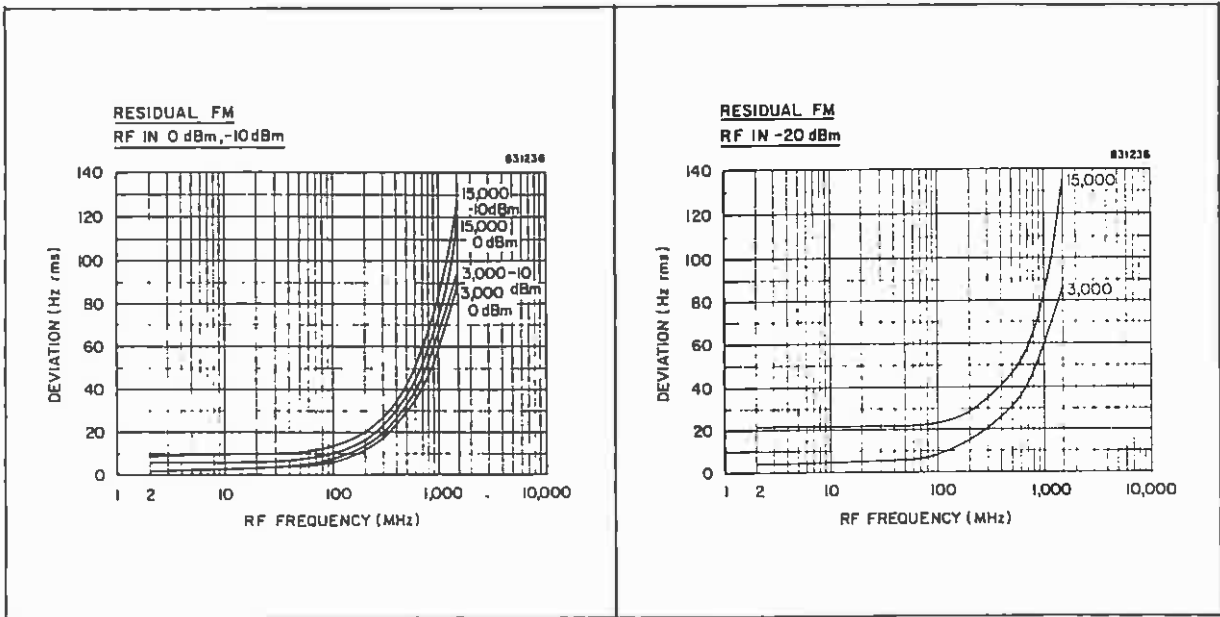

Figure 2-3. Residual F.M., Typical

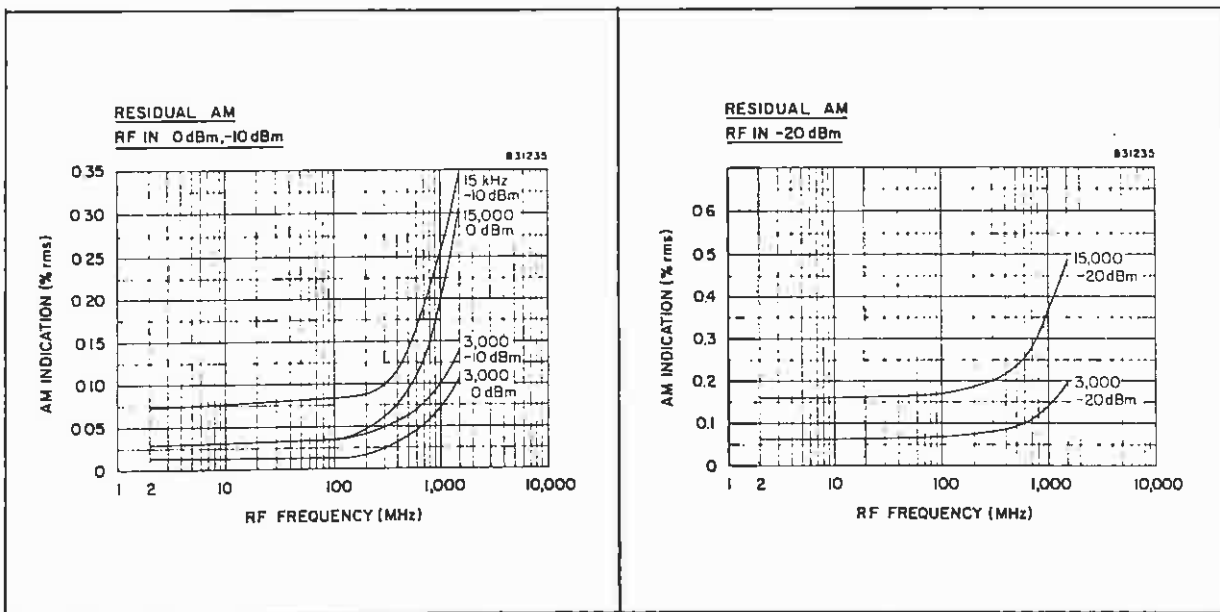

Figure 2-4. Residual A.M., Typical

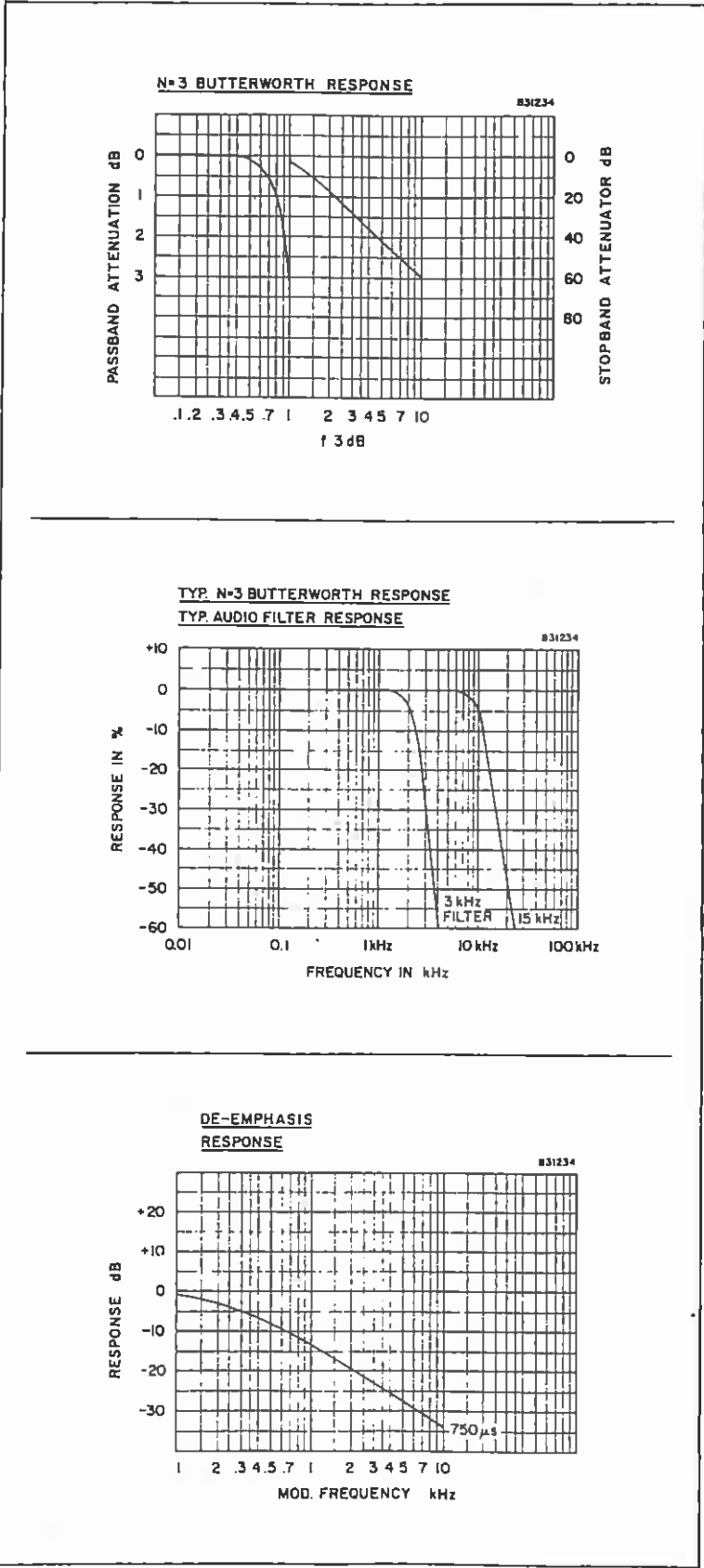

Figure 2-5. Audio Response, Typical

¶2-4a, Continued.

noise is not linear, and is a function of the carrier-to-noise ratio and the modulation waveshape. In most measurement situations involving sinusoidal modulation, noise suppression is approximately 30%.

For example, if the peak residual indicated without modulation is 100 Hz, and 10 kHz deviation is added, the resulting display would be 10.07. (Since the 0.7 multiplier is an approximate value, there will be variation. However, the use of that figure guarantees that the resulting display will always be within specification.) The assumption made is that the noise is gaussian and that the carrier-to-noise ratio exceeds 20 dB.

True r.m.s. measurements of the recovered audio signal will provide a more precise indication of modulation in the presence of large amounts of noise.

b. A.M. Measurements. The 8210 makes possible fast, accurate indications of amplitude modulation. Optimum accuracy is achieved with input signal levels between -10 and +10 dBm (for lowest residuals), and the minimum bandwidth consistent with the modulation frequency. As discussed above for f.m., noise suppression does occur, and the 0.7 multiplier is used to subtract added noise.

c. Spurious Responses. Most frequency-translating devices rely on a non-linear circuit element to produce the multiplication required for frequency translation. This non-linearity produces spurious mixing products, which tend to "cross over" the desired i.f. and change its character. In contrast, the 8210 converts frequency by using a sampler, which is very linear and which produces few spurious responses in the usual sense.

There are, however, a few points to remember when applying a sampling instrument like the 8210. If the input signal contains significant harmonic power above the third harmonic, an i.f. beat can occur and thus produce unwanted a.m. and f.m. indications.

Signals that are not harmonically related can interfere if, when they are mixed with any local-oscillator harmonic, the resulting sum frequency or difference frequency appears near the 8210's intermediate frequency.

EXAMPLE: Assume two input signals--the larger at 100 MHz, the smaller at 501.6 MHz. The local oscillator might be at 2.51 MHz so that its 40th harmonic (100.4 MHz), when mixed with the 100 MHz signal, produces a 400 kHz i.f. However, the 200th harmonic of 2.51 MHz is 502 MHz--which converts the 501.6 MHz carrier to 400 kHz also. Since the two signals are not phase coherent, a low-frequency beat will occur at the i.f. and produce spurious a.m. and f.m. indications. The offending input signal should be filtered in order to eliminate this interference.

d. Additional Applications. Information relevant to further applications of the 8210 will be found in Boonton Electronics' Application Note #19:

High Accuracy AM-FM Measurements

with the Boonton 82AD Modulation Meter.

The Application Note is available free upon request to Boonton Electronics.

Inquiries regarding application of the 8210 to specific customer requirements are invited. Please direct any such inquiries to the Applications Engineering Department of Boonton Electronics Corporation.

2-5. OPERATING INSTRUCTIONS

The operation of The Model 8210 is essentially automatic, requiring only that the operator select the proper display function and baseband filter. Paragraphs 2-5a and 2-5b summarize operating steps for a.m. and f.m. measurements, respectively.

a. A.M. Measurements.

- (1) Set the LINE switch to ON, and connect to the RF IN connector the r.f. signal that is to be measured.
- (2) After the 8210 has completed its calibration cycle, select the desired measurement bandwidth. Use the minimum bandwidth consistent with the modulation frequency.
- (3) Depress the appropriate PEAK switch, as determined by the amplitude modulation measurement to be made.
- (4) Depress the AM FUNCTION switch and the 100 RANGE switch.
- (5) Read the percentage of a.m. modulation from the LED display. The 10 RANGE may be selected if the modulation is less than 15%.

b. F.M. Measurements. Operation of the Model 8210 for f.m. measurements is basically the same as for a.m., except for the selection of Function and Filter. For f.m. measurements, depress the FM FUNCTION switch and the appropriate RANGE and PEAK switches.

Either a low-pass filter or the 750 μ s de-emphasis filter may be selected for the measurement. The de-emphasis filter may be placed before or after the modulation display, according to an internal jumper selection. Units shipped from the factory are normally wired for de-emphasis before the display.

c. Level Function. The "Level" function is included in the Model 8210 to indicate the relative a.m.-detector operating point; it is required only when an external indicator is used for making an a.m. measurement. When the 8210 is operating properly, depressing LEVEL should always result in a number between 0.95 and 11.5 on its digital display. If the reading on the external indicator is now multiplied by 10.00, then divided by the Level indication, the external indicator will be properly scaled.

The LEVEL pushbutton serves another purpose. If a malfunction occurs during calibration, a condition code (the letters cc, followed by a number), will appear on the digital display. It means that proper calibration could not be accomplished. (Refer to Section IV for the meaning of each condition code.) Depressing the LEVEL pushbutton releases the error condition, and measurements can be made. Note, however, that the detector that malfunctioned will not be properly calibrated.

In addition, the LEVEL button is utilized in several of the test routines provided for troubleshooting the 8210. These routines are described in detail in Section IV.

2-6. PERFORMANCE VERIFICATION

The following tests may be performed when the Model 8200 is first received. Thereafter, performance verification should be needed only after repair to the instrument.

NOTE: In these verification procedures, some settings or results are followed by data in parenthesis. These parenthetical entries apply to instruments with the -01 Option installed

a. Test Equipment Required. Table 2-2 lists all test equipment required for verification of performance of the 8210. Other models of test equipment that meet or exceed the Critical Specifications may be used instead.

Table 2-2. Recommended Test Equipment for Performance Verification

EQUIPMENT	CRITICAL SPECIFICATIONS	SUGGESTED MODEL
Signal Generator	A.M.-F.M., 0.01 to 520 MHz, -30 to +10 dBm level. T.H.D. <0.05% at 75 kHz Deviation at 100 MHz	Boonton Electronics 102E-19
Signal Generator	C.W., 1.5 GHz, -30 to +7 dBm	Hewlett-Packard 8660C & 86603A
Crystal- Controlled Source or Synthesizer	< 3 Hz residual f.m. at 500 MHz in 15 kHz bandwidth	Ailtech 460
Voltmeter	True r.m.s., 10 mV full- scale sensitivity, 100 kHz bandwidth	Boonton Electronics 93AD
Double-Balanced Mixer	+7 dBm, l.o. Range of l.o. & r.f.: 0.5 - 500 MHz	Mini-Circuits ZAD-1
Audio Oscillator	Range: 20 Hz - 20 kHz < 0.1% t.h.d.	Hewlett-Packard 204C
Resistor	10 k Ω , 1/4 W, 5%	Allen Bradley AB-EB
Resistor	620 Ω , 1/4 W, 5%	
Power Supply	+10 V, d.c.	Power Designs 5015T
Capacitor	1000 μ F, 6 w.v.d.c.	-----
Distortion Analyzer	Range: 20 Hz - 20 kHz Resolution: 0.1% t.h.d.	Radiometer BKF10

S2-6, Continued.

b. R.F. Input Sensitivity.

- (1) Connect the 8210 and test equipment as shown in Figure 2-6.
- (2) Depress the switches of the 8210 as indicated in Figure 2-6.
- (3) Apply a 10 MHz, 10 mV r.m.s. signal from the Model 102E-19 signal generator to the RF IN connector of the 8210. The 8210 should indicate "lock" and adequate signal level for a measurement.
- (4) Change the r.f. input to 500 MHz. Indications should be the same as in Step (3).
- (5) Connect the Model 8660C signal generator to the RF IN connector of the 8210. Set the signal generator's controls to provide an r.f. input of 30 mV, r.m.s., at 1500 MHz. Indications as in Step (3).

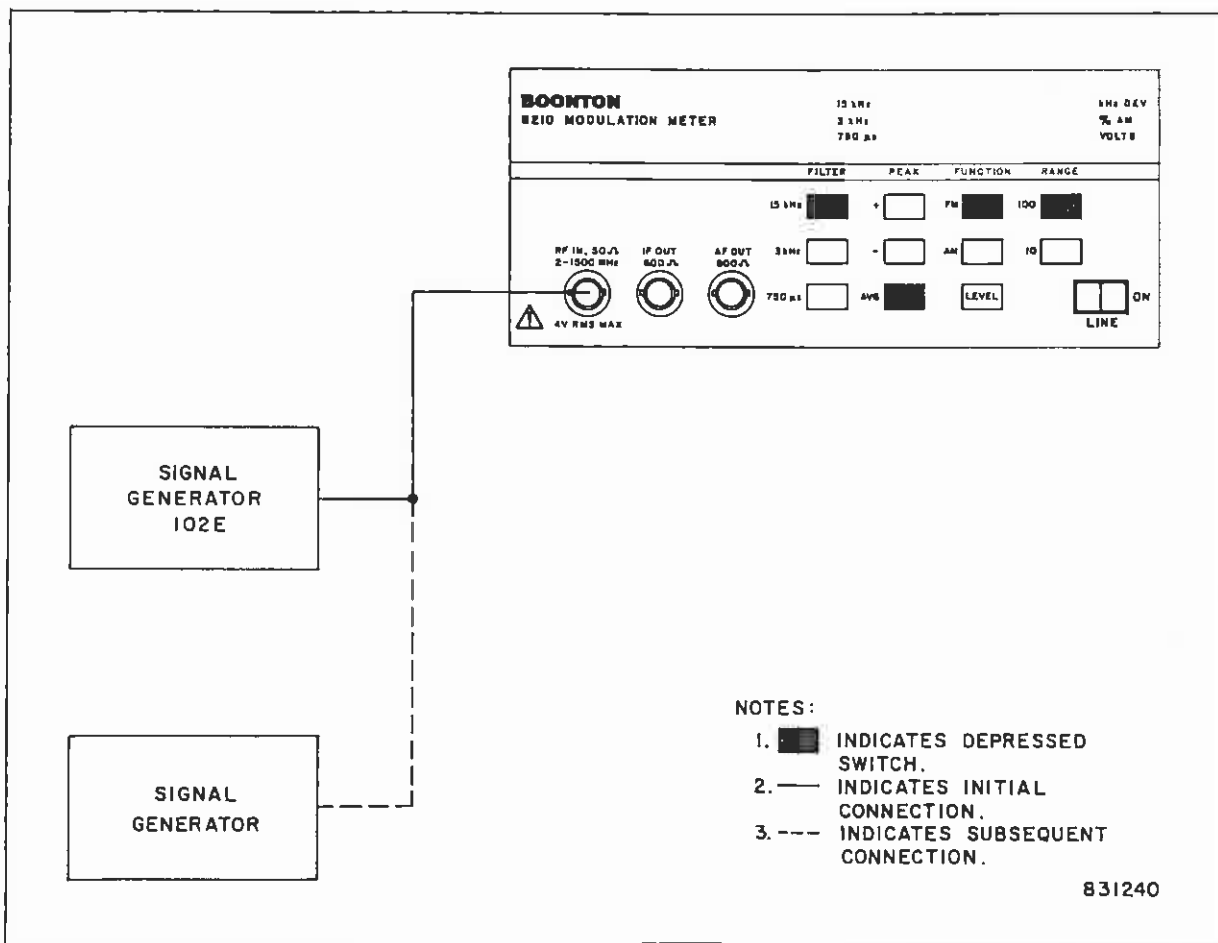

Figure 2-6. Test Setup: R.F. Input Sensitivity

c. Deviation Accuracy. Verification of the deviation accuracy of the 8210 is not usually required. If there is any doubt as to the operation of the internal calibrators, refer to Section IV for maintenance instructions, or to Appendix A for operation of the calibrators.

§2-6, Continued.

d. Residual F.M.

- (1) Connect the 8210 and test equipment as shown in Figure 2-7.
- (2) Apply the 500 MHz signal, at 0 dBm, from the test source to the RF IN connector of the 8210.
- (3) Depress the switches of the 8210 as indicated in Figure 2-7.
- (4) Connect the r.m.s. voltmeter (without 600 Ω termination) to the AF OUT connector on the 8210.
- (5) Set the voltmeter for 100 kHz bandwidth and 30 mV full-scale sensitivity. The voltmeter should indicate less than 13.3 mV (26.6 mV).
- (6) Depress the 8210's 3 kHz FILTER switch. The voltmeter should read less than 10 mV.

NOTE: The display of the 8210 indicates true peak deviation; therefore the display's readings will always be two to three times higher than the r.m.s. readings of the voltmeter.

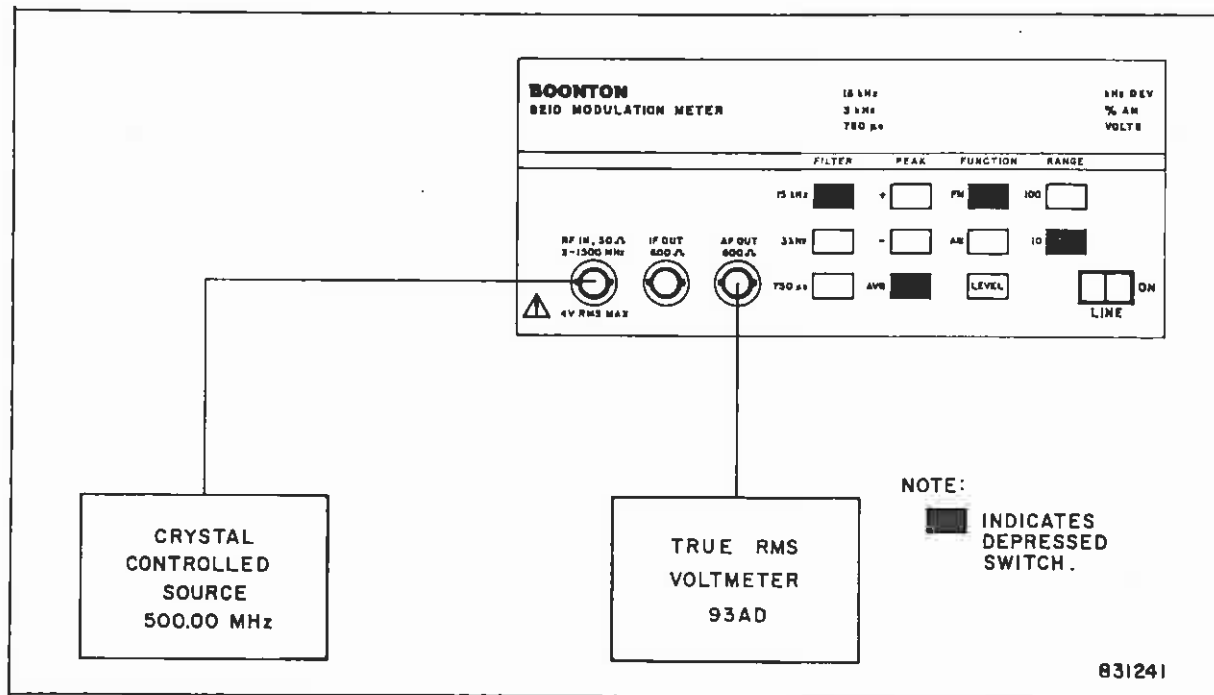

Figure 2-7. Test Setup: Residual F.M. and Residual A.M.

e. Residual A.M.

- (1) Connect the equipment as shown in Figure 2-7.
- (2) Set the 8210's controls as indicated, but select the AM FUNCTION.
- (3) Set the voltmeter to 100 kHz bandwidth and 100 mV sensitivity.
- (4) The voltmeter should indicate less than 50 mV (70 mV).
- (5) Set the 8210's FILTER to 3 kHz, and voltmeter sensitivity to 30 mV.
- (6) The voltmeter should indicate less than 30 mV.

§2-6h, Continued.

- (5) Increase the frequency to 7.5 kHz (15 kHz). The indicated a.m. should be between 58.8% and 61.2%.
- (6) Increase the frequency to 15.0 kHz (30 kHz). The indicated a.m. should be between 40.4% and 44.3%.

i. F.M. Audio Distortion.

- (1) Connect the 8210 and test equipment as shown in Figure 2-9.
- (2) Set the controls of the 8210 as shown.
- (3) Set the signal generator to 100 MHz, 0 dBm, and external f.m.
- (4) Adjust the level of the audio oscillator for 75 kHz peak deviation at a 1 kHz rate.
- (5) The indicated distortion should be less than 0.25%.
- (6) Repeat Step (4) for modulation rates of 50 Hz and 10 kHz.

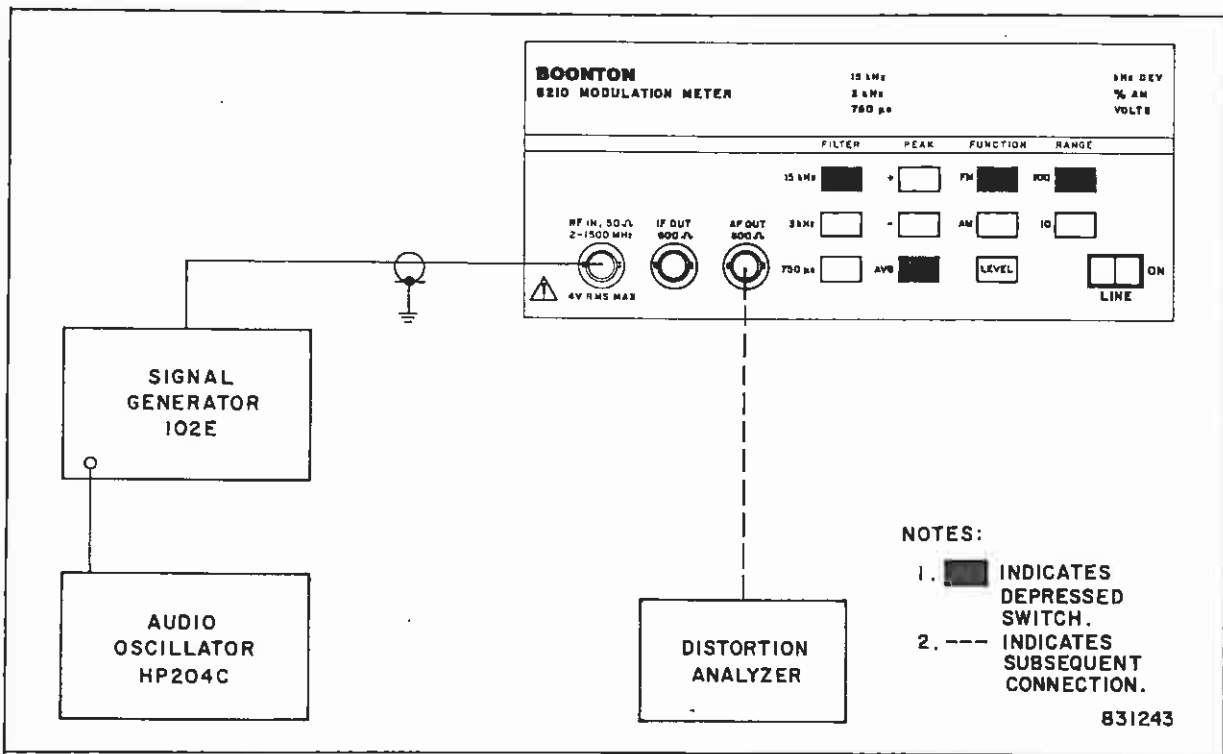

Figure 2-9. Test Setup: F.M. Audio Distortion and F.M. Rejection

j. F.M. Rejection.

- (1) Connect the equipment as shown in Figure 2-9.
- (2) Set the controls of the 8210 as indicated.
- (3) Adjust the audio oscillator's frequency to 1 kHz; adjust its amplitude for a 100 kHz peak deviation.
- (4) Change the 8210's FUNCTION to AM and its RANGE to 10.
- (5) The display should indicate less than 1.0%, peak.

§2-6, Continued.

k. Audio-Frequency Response, 3 kHz.

- (1) Connect the equipment as in Figure 2-9.
- (2) Set the 8210's controls as shown.
- (3) Adjust the audio oscillator's frequency to 300 Hz, then adjust its amplitude until the 8210 reads 100.0 kHz.
- (4) Without changing the audio oscillator's level, adjust its frequency to exactly 3.00 kHz.
- (5) The Model 8210 display should indicate between 67.5 and 73.8 kHz.

l. Audio-Frequency Response, 750 μ s De-emphasis.

- (1) Connect the equipment as in Figure 2-9.
- (2) Set the 8210's controls as shown.
- (3) Adjust the audio oscillator's frequency to 212.2 Hz, then adjust its amplitude until the 8210's display indicates 100.0 kHz.
- (4) Change the 8210's FILTER to 750 μ s.
- (5) The display should read between 68.0 and 73.5 kHz deviation.

m. A.M. Depth Accuracy. Verification of the a.m. depth accuracy of the 8210 is not required. If there is any doubt as to the operation of the internal calibrators, refer to Section IV for maintenance instructions, or to Appendix A for operation of the calibrators.

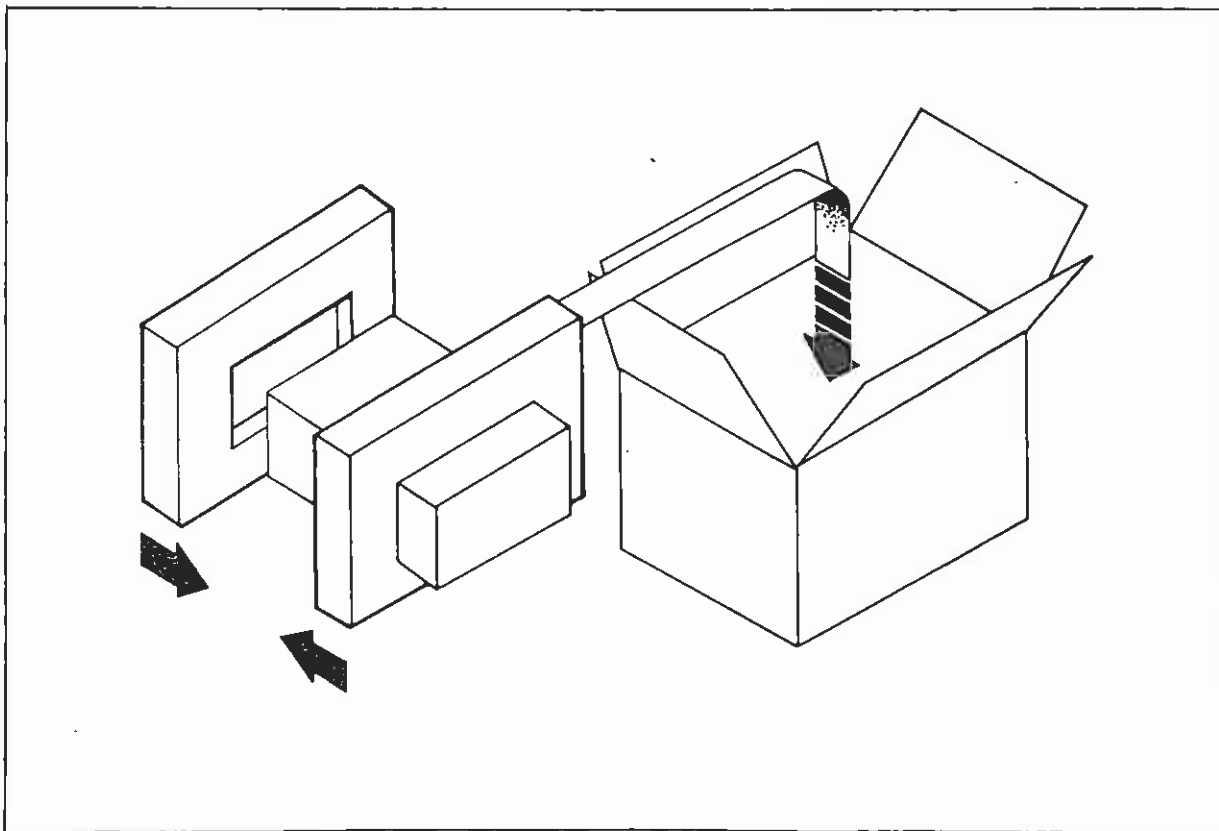

Figure 2-10. Packaging Diagram

SECTION III

THEORY OF OPERATION

3-1. INTRODUCTION

The 8210 is a compact, microprocessor-controlled, internally calibrated, a.m.-f.m. modulation meter that covers the carrier-frequency range of 2 MHz to 1.5 GHz. Amplitude modulation or frequency modulation is displayed on a four-digit LED display that provides a maximum resolution of 0.01% a.m. or 10 Hz deviation. Signal acquisition, display operation, calibration, and instrument control is accomplished using a microprocessor.

Operation of the 8210 is fully automatic. The largest signal present at the RF IN connector is converted to a 400 kHz intermediate frequency, which is adjusted to a convenient level for a.m. measurements. The modulation depth of a.m. signals is equal to the peak amplitude of the recovered audio signal divided by the d.c. level of the a.m. detector. The deviation of an f.m. signal is equal to the peak amplitude of the recovered signal. The recovered modulation is converted into a proportional d.c. level, then into a digital display, by microprocessor-controlled detectors and an analog-digital (A-D) converter.

3-2. CIRCUITS: GENERAL DISCUSSION

For this discussion the circuits of the 8210 are grouped by function, as follows: r.f., i.f., calibrator, a.f., logic, and power-supply circuits. Refer to Figure 3-1, a simplified block diagram of the 8210.

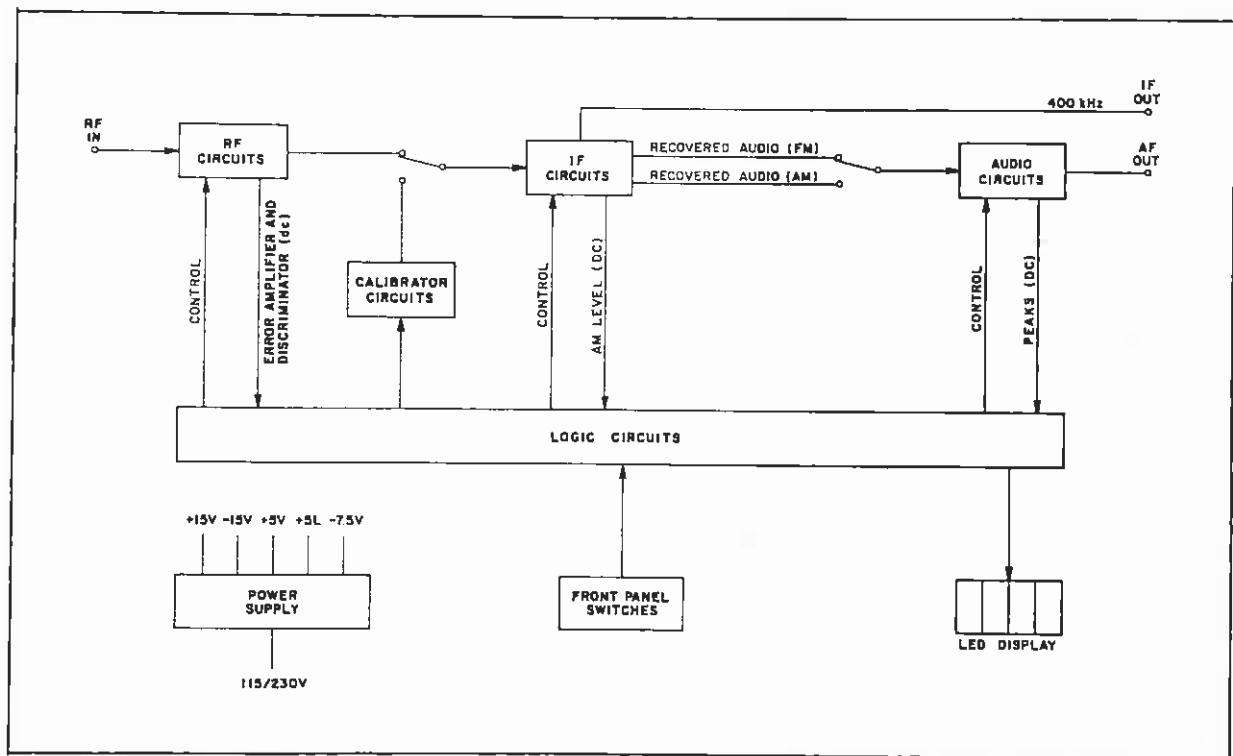

Figure 3-1. Simplified Block Diagram

a. R.F. Circuits. The r.f. input signal to be measured is applied to the r.f. circuits through the front-panel RF IN connector. This signal passes through a fixed 3 dB pad to a zero-order hold sampler. The sampler is fully bootstrapped to accept signals as large as 1 V, r.m.s., without overload.

A sampling pulse, generated from a tunable local oscillator, converts the r.f. signal into an i.f. signal at approximately 400 kHz. The i.f. signal is passed to the i.f. circuits and also through a filter to a limiter, a discriminator, and an error amplifier. Automatic frequency control is accomplished by these circuits in conjunction with the microprocessor.

b. I.F. Circuits. The i.f. signal from the sampler is filtered and amplified, then coupled to a.m. and f.m. detectors through a digital-to-analog (D-A) converter configured as a variable-gain element. The logic circuitry adjusts the converter so as to maintain a convenient d.c. level at the output of the a.m. detector. The last-mentioned is a linear active detector, which recovers the amplitude modulation of the i.f. and provides a d.c. signal proportional to the i.f. level. A portion of the a.m. detector output signal is used to drive a monostable multivibrator, which detects the f.m. modulation of the i.f. signal. Both a.m. and f.m. signals are amplified and applied to the a.f. circuits through a switch. During calibration, the signal from the r.f. circuits is disconnected from, and the calibrator signal is connected to, the i.f. circuits.

c. Calibrator Circuits. The calibrator circuits, which are activated when the 8210 is turned on, consist of a variable-modulus counter circuit and a precision attenuator. The variable-modulus counter is alternately programmed to divide the output of a 3.579 MHz crystal-controlled oscillator by eight or by ten. The resulting signal has an average frequency of 402 kHz, approximately, and a peak deviation of 44.74 kHz. This signal is used to calibrate the f.m. detector. In addition, a fixed-frequency signal is applied to a switchable attenuator, which is alternately programmed to attenuate by two-thirds and by one-third. The signal from the attenuator has an amplitude variation of two to one, and therefore is equivalent to a signal with 33.33% a.m.

d. A.F. Circuits. The recovered audio signal from the a.m. or the f.m. detector (as determined by the FUNCTION switch), is filtered by an active-filter circuit to remove i.f. components. Baseband processing circuitry, in the form of selectable low-pass filters, additional gain, and precision peak detectors--all under the control of the logic circuitry--convert the recovered signal into a digital display.

e. Logic Circuits. The logic circuits consist of a central processing unit (CPU), read-only memory (ROM), random-access memory (RAM), peripheral interface adapters (PIA), and a digital-to-analog converter (DAC). The CPU operates under control of a microprogram, stored in ROM, to monitor the frequency control, level control, peak-detector circuits, and the front-panel switches. In addition, the CPU controls and updates the front-panel displays, and operates all internal control circuits.

f. Power-Supply Circuits. The power-supply circuits convert the a.c. line voltage into well regulated d.c. voltages. Five power-supply voltages are used to operate the circuits in the 8210: +15, -15, -7.5, and separate +5 supplies for the analog and for the digital circuits.

3-3. CIRCUITS: DETAILED DISCUSSION

a. R.F. Circuits. The r.f. circuits convert the r.f. input signal that is to be measured into a 400 kHz i.f. signal. With the assistance of a microprocessor, a local-oscillator signal is generated and controlled so as to maintain this intermediate frequency. (Refer to Figure 3-2, a detailed block diagram of the r.f. circuits.)

- (1) The input signal applied to the front-panel RF IN connector, J1, is passed through connectors J2 and P1 to a fixed 3 dB pad, which consists of R2-R4. This pad reduces the r.f. level, and improves the impedance match to the incoming signal. The output of the pad is connected to a sampling gate consisting of diodes CR2a-CR2d. The sampling gate and sampler amplifier, consisting of transistors Q2

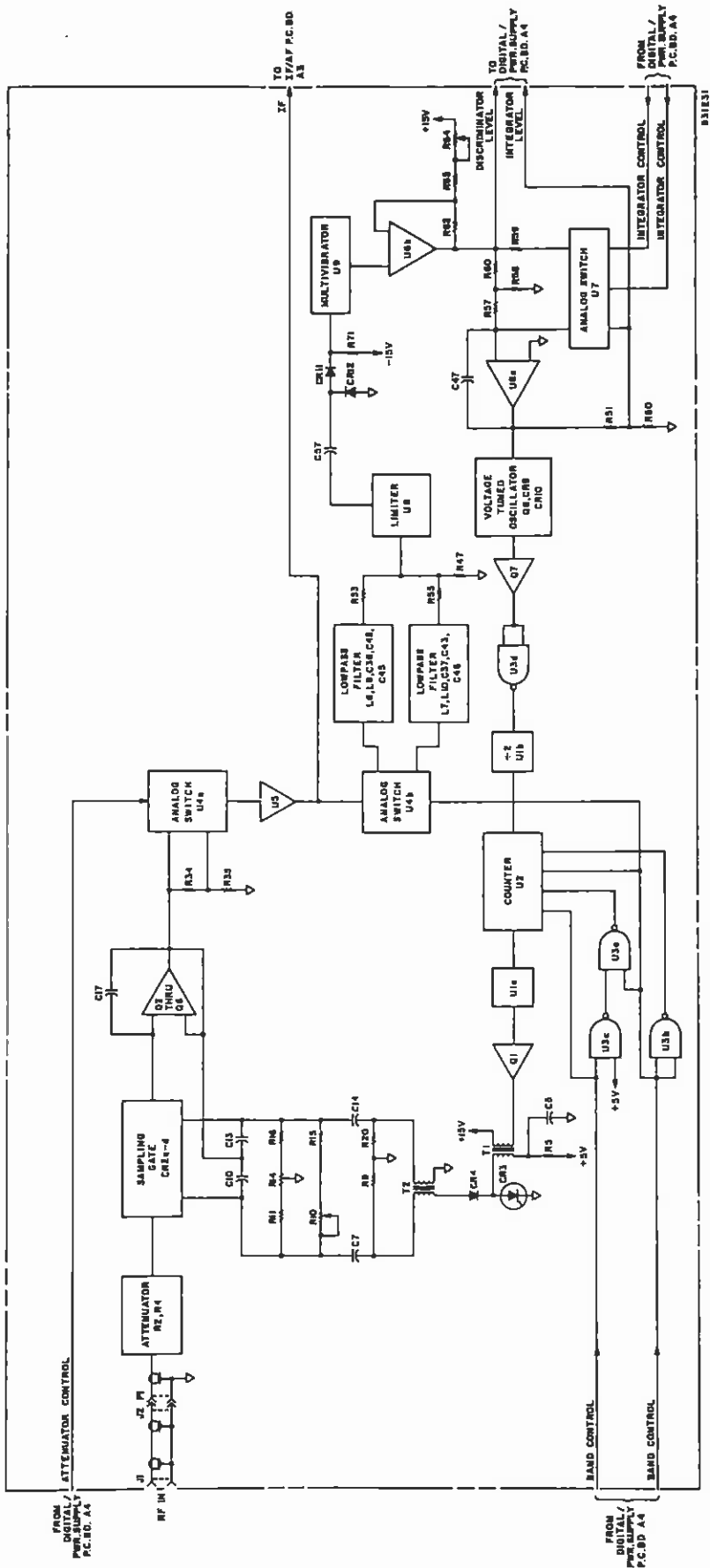

Figure 3-2. R.F. Circuits: Detailed Block Diagram

through Q6 and associated components, constitute a zero-order hold sampler.

- (2) The operation of the sampling gate is shown in simplified form in Figure 3-3. Each time the sampling gate is closed, by a short-duration pulse, the input capacitance of the sampler amplifier plus any stray capacitance is charged to a voltage that is less than the instantaneous r.f. input voltage. Before the next sample is taken, positive feedback from the sampler amplifier causes additional charge to be placed on this capacitance. Charge is added until the output voltage of the sampler amplifier is equal to the r.f. input at the time the sample was taken. This output voltage is held constant until the next sample is taken. Successive samples are taken until the r.f. waveform is reconstructed at 400 kHz. Additional feedback from the sampler amplifier maintains symmetrical reverse bias on the sampling gate. R10 adjusts the bias magnitude, and R14 adjusts the bridge balance.

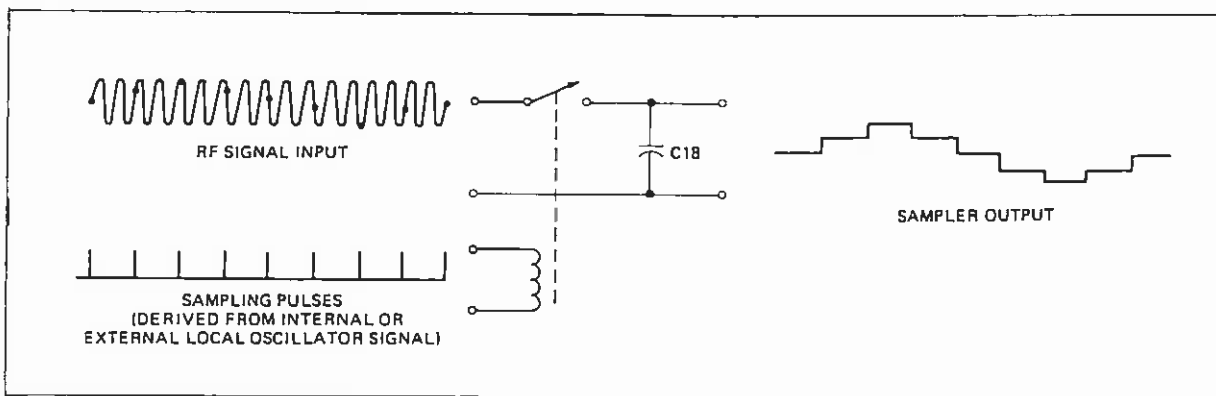

Figure 3-3. Sampling Gate: Simplified Operation

- (3) The output of the sampler amplifier is connected to a switchable 20 dB attenuator, consisting of R34, R-35, and U4a. The attenuation is selected by the control program whenever the r.f. input level exceeds approximately 100 mV. Amplifier U5 increases the signal level about four times before it is coupled to the i.f. circuits. The output of U5 is connected also to a switchable low-pass filter composed of U5b, L6, L7, L9, L10, C36, C37, C42, C43, C45 and C46. This filter eliminates most of the local-oscillator signal at the input of the limiting amplifier U8. A level-shift circuit, which consists of CR11, CR12, C57 and R71, translates the limited i.f. signal to TTL levels in order to operate U9--a monostable multivibrator. The duty cycle, and thus the average value, is proportional to frequency. R64 sets the operating level of U6b to zero volts, d.c., when the intermediate frequency is 400 kHz.
- (4) The output of U6b is connected to integrating amplifier U6a through a voltage divider formed by R58, R60. This attenuation is needed to preserve low-frequency f.m. response at high carrier frequencies. CMOS switch U7 can be programmed to "dump" the integrator or to bypass the input voltage divider on command from the logic circuits. The output of the integrator is resistively coupled to the varactor diodes CR9 and CR10.
- (5) The local oscillator, composed of FET Q8 and associated components, is voltage-tuned. The frequency is determined by a tuned circuit consisting of L2 and varactor diodes CR9 and CR10. As the voltage at the output of U6a varies from +11 to -11 volts, the oscillator's

frequency changes from less than 30 MHz to approximately 40 MHz. Level shifter Q7 increases the signal to TTL-compatible levels to drive both U3d (a buffer), and U1b (a divide-by-two stage). U2 and U3a-c are configured as a programmable counter, able to divide by four, by five, or by six, as controlled by the logic circuitry. By successively changing the divide modulus, three overlapping bands (extending together over one octave), are generated.

- (6) The sampling pulses are generated by the step-recovery diode CR3, amplifier Q1, and transformer T1. Initially, diode CR3 is forward biased from the +5 volt supply through R5. U1a generates a narrow pulse from the output of the counter. This pulse, amplified by Q1, drives the step-recovery diode into reverse conduction; however, CR3 does not "open" until all of its stored charge is depleted. At that time the diode recovers and produces a large narrow pulse, which is coupled to the sampling bridge through T2, a balun transformer. The output of T2 is two nearly equal opposite-polarity pulses. If the two pulses were exactly equal and opposite, they would cancel one another at the input and output of the sampling bridge. Since such equality is never the case, however, R14 is adjusted to null the bridge-input signal--and thereby the signal fed out of the RF IN connector.
- (7) Frequency acquisition occurs in the following manner: If no carrier is present at the input (RF IN), the discriminator level indicates that the frequency is high. The integrator ramps toward the negative supply rail until it has exceeded 11 volts. At that time the integrator is reset to 0 volts, the integrator attenuator is bypassed, and the count-modulus of the band counter is changed. This process continues until a carrier signal is applied to the RF IN connector.
- (8) When a carrier is applied, an i.f. signal will be produced at a frequency that is between zero and one-half of the sampling rate. This signal is hard-limited, then applied to a discriminator which, in turn, causes the integrator to move toward one or the other of the supply rails--depending on whether the i.f. is high or is low. If a valid 400 kHz i.f. is produced the integrator stops, and the by-pass of the integrator attenuator is removed. If no valid i.f. occurs, the integrator output will eventually exceed either +11 or -11 volts. Then the integrator will be reset, and the band-counter modulus will be either increased or decreased. In this way, all possible input frequencies can be made to produce a valid i.f.
- (9) The capture performance of the system is determined principally by the limiter's gain and the bandwidth of the sampler. Weaker signals at the r.f. input (non-harmonically related to the signal of interest) will be suppressed, since the largest signal present will drive the limiter to a low-gain state. These weaker signals will appear as f.m. sidebands at the output of the limiter.

b. I.F. Circuits. The i.f. circuits recover the a.m. and f.m. signals from the frequency-shifted input signal. These circuits also provide a sample i.f. signal to the front-panel IF OUT connector; in addition, for a.m. measurements, they provide a d.c. signal proportional to the i.f. level. (Refer to Figure 3-4, a detailed block diagram of the i.f. circuits.)

- (1) The 400 kHz i.f. signal from the r.f. circuits is connected to amplifier U2 through a low-pass filter that consists of inductors L1 through L3, capacitors C1-C2, and resistors R3, R5 and R6. Variable resistor R5 reduces the filter's amplitude-response variations, which are due to component tolerances. It is adjusted so as to give minimum a.m. indication when an f.m. signal is applied. Amplifier U2 has a closed-loop gain of four (approximately), as determined by

R3, R5, R6 & R8. The signal is then connected to calibrator switch U3, and a.c.-coupled to DAC U4. The gain of the DAC is determined by the digital byte appearing at inputs B1-B8. The logic circuitry varies this byte in order to maintain the d.c. output of the a.m. detector between 0.5 and 0.6 volts. The amplifier that consists of U5, Q3, and associated components, increases the i.f. level and provides the high output impedance necessary for driving the linear active detector circuit. The signal at the emitter of Q3 is buffered by U8 and routed to the IF OUT connector.

- (2) The active detector circuit, which comprises transistors Q4 through Q6, diodes CR6-CR7, and associated components, converts the input current into two half-wave-rectified signals. The circuitry of Q4-Q6 yields maximum gain and a high output impedance for driving the feedback network. The two half-wave-rectified signals at the outputs of CR6 and CR7 are added to complete the feedback path.
- (3) The output at detector diode CR7 is a signal that contains a d.c. component proportional to i.f. level, and an a.c. component proportional to modulation depth. This signal is lightly filtered by R47 and C27, and amplified by U9a. The output of U9a is connected to the a.m.-f.m. switch U14.
- (4) A portion of the linear active detector's output is coupled to a limiter circuit via impedance transformer Q2 and associated components. The limiter, consisting of CR4, CR5, R22 & R17, removes most a.m. from the i.f. signal. The resulting signal is amplified to TTL levels by amplifier Q1, then differentiated by C9, R19 and R20. The TTL gates U6a and U6b amplify the differentiated signal into a narrow TTL pulse to drive U7, a monostable multivibrator.
- (5) The period of U7 is 1.25 μ s, approximately. The network consisting of R43-R46 and CR8 confines the peak-to-peak amplitude of U7's output to four volts. As the intermediate frequency changes, the duty cycle of the multivibrator--and consequently the average value of the waveform--changes proportionally.
- (6) The signal is lightly filtered by R48 and C28, then amplified and level-shifted by U9b. The signal is routed to the a.m.-f.m. switch U10, and to the audio circuits.

c. Calibrator Circuits. The calibrator circuits provide the reference calibration signals for the 8210's a.m. and f.m. detectors. See Figure 3-5. (In addition to the circuit description given below, technical information on design and operation of the calibrator circuits appears in Appendix A.)

- (1) The 1.79 MHz signal from U5a, pin 8, is connected to the clock input of synchronous counter U9. The counter is configured to self-load its data inputs at the end of each count cycle. By varying the input data with an 874 Hz signal from U1f, pin 2, the divide modulus is changed from four to five. The signal that results synchronously switches from 357.9 to 447.4 kHz, producing an average frequency of 402.6 kHz and deviation of 89.48 kHz, p-p. This signal is used to calibrate the f.m. discriminator. The signal is connected to data selector U12, along with a signal at 447.4 kHz from U3, pin 6, and an 874 Hz signal from U1f, pin 2. The outputs of the data selector are controlled by the signals from U-16, pins 39 and 17. During the calibration cycle U16, pin 17, is "low;" pin 36 is set "high" for a.m. calibration, and "low" for f.m. calibration.
- (2) When the calibration routine initially selects AM FUNCTION, the outputs of the data selector are the signal from U3, and the 874-Hz signal from U1f, pin 2. The 447.4 kHz signal is routed through a low-pass filter consisting of L1, L2, C6, C8 and C10 to the i.f.

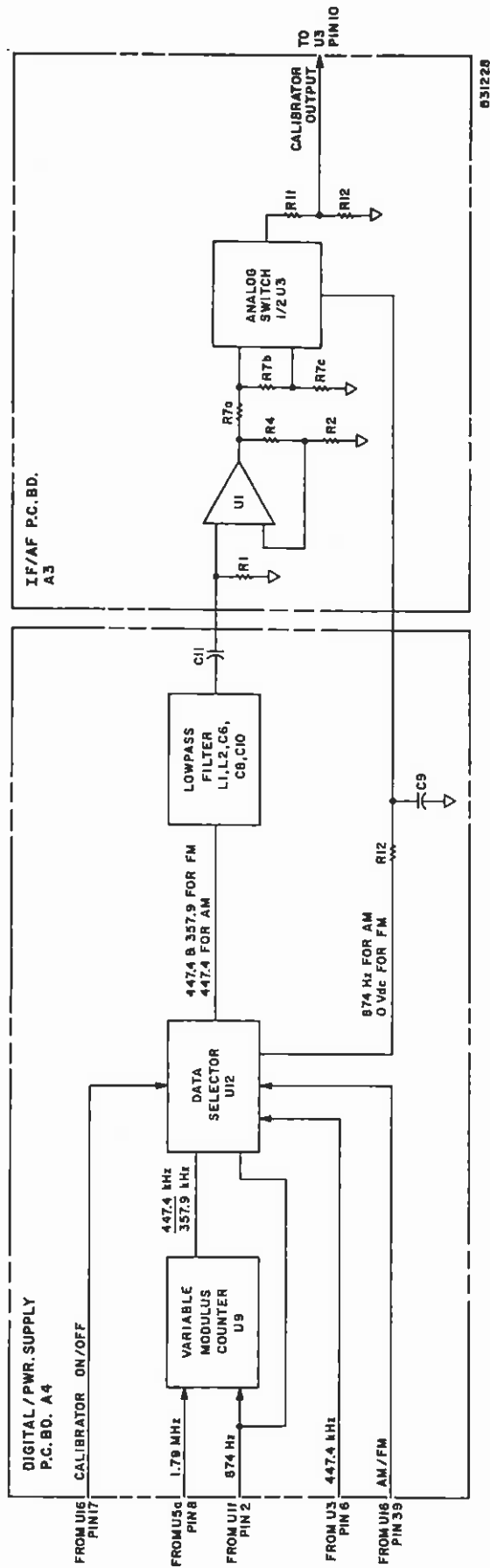

Figure 3-5. Calibrator Circuits: Detailed Block Diagram

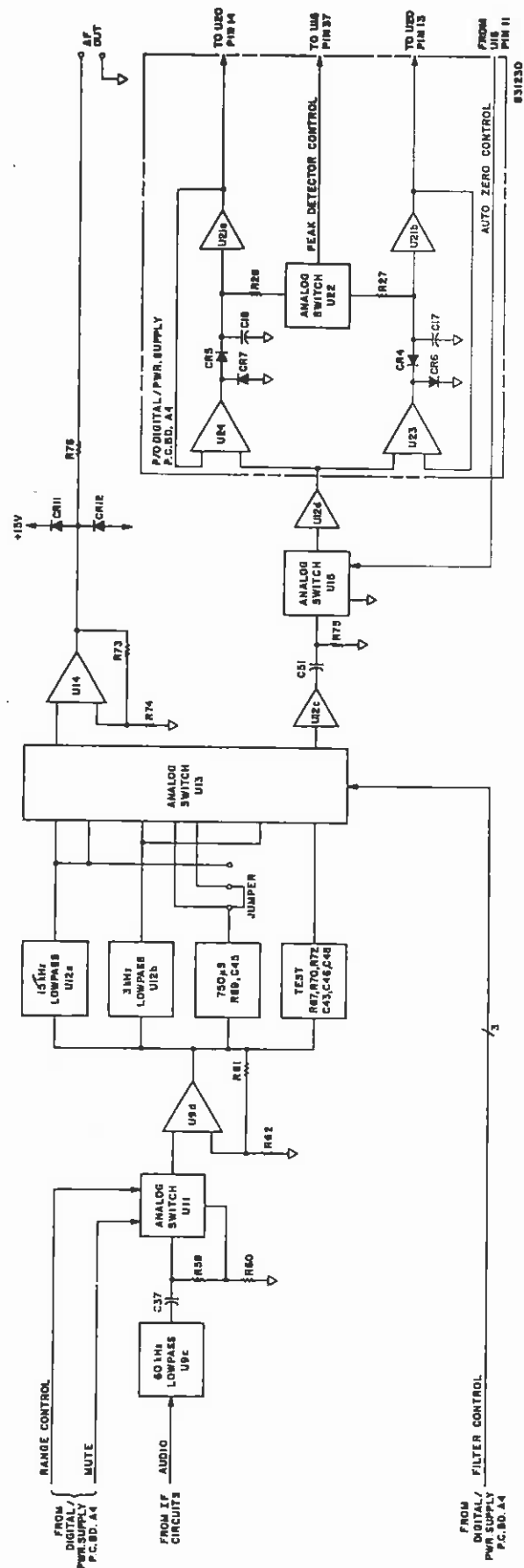

Figure 3-6. A.F. Circuits: Detailed Block Diagram

circuits. This signal is amplified ($\times 2$) by A3U1 and applied to the voltage divider A3R7. The analog switch A3U3 is controlled by the 874-Hz signal from A4U12 so as to switch between two taps of the divider. The voltage ratio is exactly two, therefore the equivalent a.m. is 33.33%. This signal is coupled through an attenuator (R11 and R12) and the second half of switch A3U3 to the i.f. circuitry.

d. A.F. Circuits. The audio circuits process the recovered modulation signal supplied from the a.m. or the f.m. detector circuits--as determined by the front-panel FUNCTION switch. The recovered signal is filtered and converted to a d.c. level, which is then measured; the result is presented on the front-panel LED display. Refer to Figure 3-6.

- (1) The signal from the output of the a.m.-f.m. switch U10, is filtered by active filter U9c and associated components. This filter is part of a three-pole 60 kHz filter, which removes most of the i.f. component from the recovered signal. The filtered signal is then a.c. coupled to a 20 dB attenuator: R59, R60. CMOS switch U11 selects either the signal, or the attenuated signal, as determined by the front-panel RANGE switch. Additionally, the logic circuitry can program U11 to disconnect the recovered signal in order to prevent audio-circuit overload when the instrument is unlocked.
- (2) The signal is then amplified ($\times 11$) by U9d and is coupled to the 15 kHz filter, the 3 kHz filter, and the 750 μ s de-emphasis network. U12a and associated components form the 15 kHz filter; U16b and associated components form the 3 kHz filter. Both are three-pole Butterworth types. The 750 μ s de-emphasis network is a single RC section: R69, C45. A jumper circuit is provided to give the option of connecting the de-emphasis network either before or after the measuring circuits.
- (3) CMOS switch U13 selects one of the three filters, as determined by the front-panel FILTER switch. In addition, the logic circuitry can program U13 to select--during calibration--a filter consisting of R67, R70, R72, C43, C46 and C48. One of the outputs of U13 is amplified ($\times 2.8$) by U14 and routed to the front-panel AF OUT connector. The other output is buffered by voltage-follower U12c and a.c. coupled to U15, an auto-zero switch. U15 is operated by the logic circuitry to disconnect the recovered signal for a period of time adequate to determine the output of the peak detectors with no input. The switch is then closed, and the modulation signals are connected through buffer U12d to the peak detectors.
- (4) The positive-peak detector consists of U24, U21a, CR1, CR3 and C18. During the positive excursion of the modulating signal, the output of U24 is driven positive; C18 then charges through CR1. U21a buffers the voltage across C18, and adds a small offset. When the output of U21a reaches a value equal to the peak of the waveform plus a small increment, the output of U24 goes negative and thus terminates the charging. The voltage at the output of U21a is then equal to the positive peak of the modulating signal.
- (5) Similarly, U23, U21b, CR4, CR6 and C17 constitute a negative-peak detector. In addition, U22 provides a means for resetting both detectors for auto-zero measurements.

e. Logic Circuits. The logic circuits generate all control and display functions in the 8210. The logic circuits consist of a CPU, 4096 bytes of ROM, 256 bytes of RAM, two PIA's, a DAC, and several IC gates and drivers.

The CPU, U8, is controlled by a program stored in ROM (U11, U13). Temporary program variables and subroutine return addresses are stored in RAM (U14, U15). The 8210's control functions are directed by U16, a PIA; keyboard

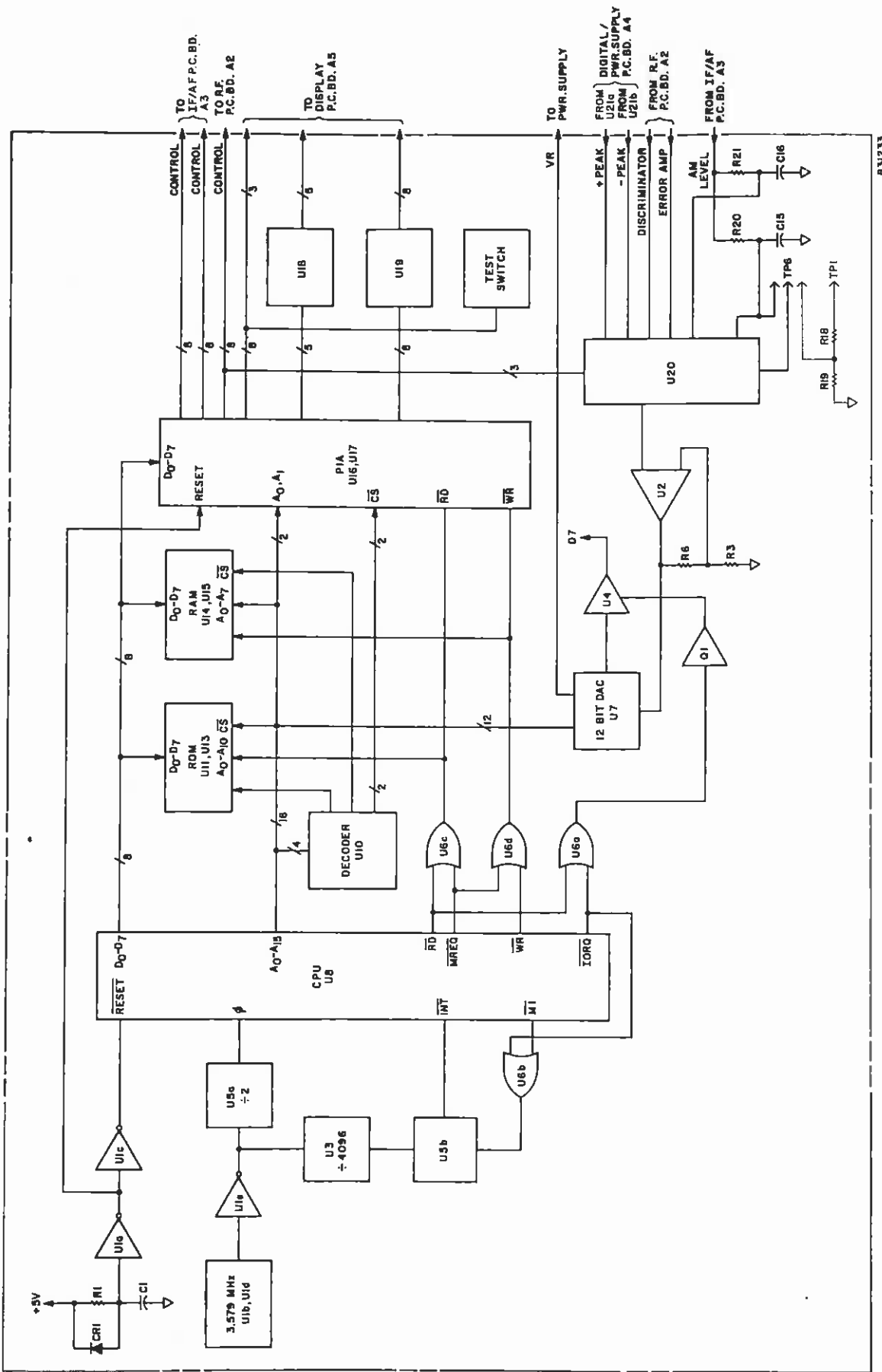
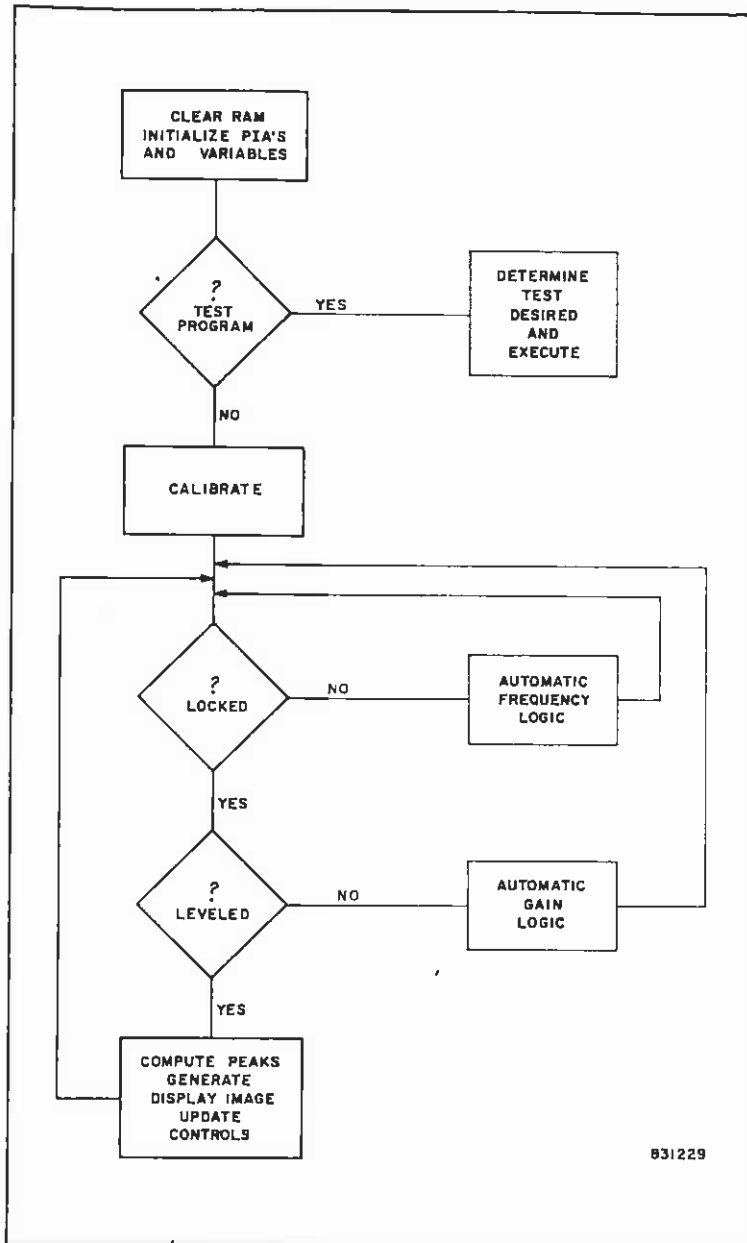

Figure 3-7. Logic Circuits: Detailed Block Diagram

and display functions are directed by the PIA U17. See Figures 3-7 and 3-8.

- (1) The control program initializes the RAM and PIA circuits and checks the status of the test switch during the power-up sequence. The display is then enabled, and interrupt processing of the keyboard and the display begins. As each digit of the display is updated,



each row of keys is tested simultaneously, and any key closures are detected. The calibration sequence then starts; when it ends, the main program loop begins. The latter places the highest priority on successful frequency acquisition, then on establishing the proper i.f. level, and finally on measuring the recovered signal. The program checks level and frequency each time through the main loop, so i.f. errors are detected immediately. When proper operating parameters are established, the recovered signal is processed.

(2) The program executes an auto-zero cycle each time a measurement is made. The audio signal is turned off, the peak detectors are reset and released, and both detectors are read. The information is stored temporarily. The peak detectors are reset, audio is turned on, and the detectors are released. They are read again and the "zero" information is subtracted. The display is then updated with the data determined by the setting of the front-panel PEAK switch.

(3) All d.c. voltage measurements are made by the successive - approximation A-D converter consisting of U7, U4, Q1, and associated components. The successive trial values are software generated, and sent to the 12-bit DAC (U7) via the address bus of the CPU. An

Figure 3-8. Program Flow Diagram

I-O read cycle (signalled by IORQ = RD = LO) returns the comparison (made by U4) of the DAC value and the input d.c. signal on data line D7. A complete conversion requires 12 successive tests to converge within 1 LSB. U2 serves as a fixed-gain buffer to isolate U20, the CMOS multiplexer, from the A-D converter circuit's low input impedance.

- (4) The CMOS multiplexer, U20, is operated by the program to select various voltages from the 8210's circuits. Both peak detectors are

connected to it, as are the outputs of the integrator and the discriminator from the r.f. circuits, and the d.c. level from the a.m. detector. The a.m. detector output is filtered by R21 and C56 to provide one a.m.-level input and by R20 and C15 to provide another. The two a.m. detector inputs are used during i.f. level setting and a.m. depth measurements: the moderately filtered one for testing the level, the heavily filtered one for computing a.m.

- (5) U1b, U1d, and U5e constitute a crystal-controlled oscillator, with the 3.58 MHz crystal frequency divided by a factor of two by U5a. The output of U5a is connected to the clock input of the CPU. The 3.58 MHz signal is also divided by a factor of 4096 by U3, to generate the 1.1 ms interrupt signal. U1b is clocked by this signal going high, which activates the INT line of the CPU and causes an interrupt to occur. The CPU recognizes the interrupt; it acknowledges by setting lines IORQ and M1 low. Thus U5b is reset, and the interrupt condition is cleared. The interrupt program updates the display and interrogates the keyboard, then returns to the main program.
- (6) U10 decodes the address lines to enable the IC's of ROM, RAM, and PIA. The program ROM is located from address 0 to FFF hex; the RAM is located at addresses 1000 to 10FF hex; the display PIA, IC7, is located at address 3000 hex; and the control PIA, IC6, is located at address 2000 hex.
- (7) A circuit composed of U1a, U1c, R1, C1 and CR1 resets the CPU and PIA IC's at power-up.

f. Power-Supply Circuits. The power-supply circuits provide d.c. operating power for all other circuits of the instrument. Regulated output voltages of +15, -15, +5(L), +5, and -7.5 volts are provided. The power supplies are designed to operate from a 100, 120, 220, or 240 volt (nominal) a.c. power source. Refer to Figures 6-1 and 6-2.

- (1) Power is applied to the primary windings of power transformer T1 through the power connector P1, line fuse F1, line-voltage selector switch S1, and the front-panel LINE switch. S1 is set by the user in accordance with the available a.c. power source.
- (2) Two separate secondary windings of T1 supply a.c. voltages to the rectifier circuits, through connector J6. Bridge rectifier CR8 and capacitor C23 generate an unregulated d.c. output, which supplies power to U26 (a five volt, three-terminal regulator). CR10 and CR15 protect the regulator from reverse voltages during power-on and power-off transients. C26 and C33 improve the transient response of the regulator. The unregulated output of CR8 also is connected to a second regulator, U25, which is enclosed in the feedback loop of U29c. This connection produces a precision +5 volt supply for the analog circuitry of the 8210.
- (3) The reference output of U7 is filtered by R31b and C34, and applied to pin 3 of U29a. This provides a reference for the generation of the +15 volt supply. R31 is actually an array of eight matched 10 k Ω resistors, three of which are connected in series between +15 volts and ground. Since the junction of R31a and R31c is connected to pin 2 of U29a, the feedback loop will cause the voltage at this point to be +10.00 volts within the offset of U29a. Consequently, the voltage at the junction of R31c and R31e will be +5.00 volts. This voltage becomes the reference for U29c, which generates the precision +5 volt supply.
- (4) The -15 volt supply is generated by U28 and U29b, and associated components. A sample of the regulated output voltage of the supply,

¶3-3f(4), Continued.

developed by the resistive divider composed of R31d and R31f, is compared to ground. Error voltages are amplified by U29b, and are coupled to regulator U28 in order to adjust the output voltage so as to reduce the error. In this manner the -15 volt supply is made to track the +15 volt supply.

- (5) One additional supply voltage is generated; its components are a resistive divider (R31h and R31g), and U29d. The latter is connected as a voltage follower in order to buffer the -7.5 volts at pin 5.
- (6) All regulators are protected from reverse bias by diodes both from their outputs to ground, and from their outputs to inputs.
- (7) Capacitors at input and output terminals improve the transient response of the supplies.
- (8) Diodes CR12, CR14 and CR16 ensure proper start-up of the supplies.

SECTION IV
MAINTENANCE AND ADJUSTMENT

4-1. INTRODUCTION

This section contains maintenance and adjustment instructions for the Model 8210. Symptomatic and systematic troubleshooting procedures for localizing a malfunction are given, as well.

4-2. TEST EQUIPMENT REQUIRED

The test equipment that is required for maintenance and adjustment of the Model 8210 is listed in Table 4-1, below. Other models of test equipment that meet or exceed the Critical Specifications may be used instead.

Table 4-1. Required Test Equipment for Maintenance and Adjustment

EQUIPMENT	CRITICAL SPECIFICATIONS	SUGGESTED MODEL
Signal Generator	A.M.-F.M. 0.01 to 520 MHz. -30 to +10 dBm.	Boonton Electronics 102E-19
Oscilloscope	100 MHz Bandwidth. 5 mV Sensitivity.	Hewlett-Packard 1740A
Audio Oscillator	20 Hz to 75 kHz. Constant level of 110 mV, with low distortion.	Hewlett-Packard 204C
A.C. Voltmeter	10 mV to 2 V. Accuracy 1%, 50 Hz to 1 kHz.	Boonton Electronics 93AD
Digital D.C. Voltmeter	100 mV to 20 V. Accuracy 0.15% at 15 V.	Data Precision 1350
Frequency Counter	20 Hz to 5 MHz. Sensitivity 100 mV.	Data Precision 5740
Signature Analyzer	> 3.5 MHz Operating Frequency.	Hewlett-Packard 5004A

4-3. LOCATION OF MAJOR ASSEMBLIES

See Figures 4-1 and 4-2 for the location of the major assemblies of this instrument.

4-4. REMOVAL OF MAJOR ASSEMBLIES AND PARTS

a. Instrument Covers.

- (1) Disconnect all signal cables and the power cord from the 8210.
- (2) Remove two #4-40 screws securing the top cover at the rear panel.

Digital/Power Supply PCB
(A4)

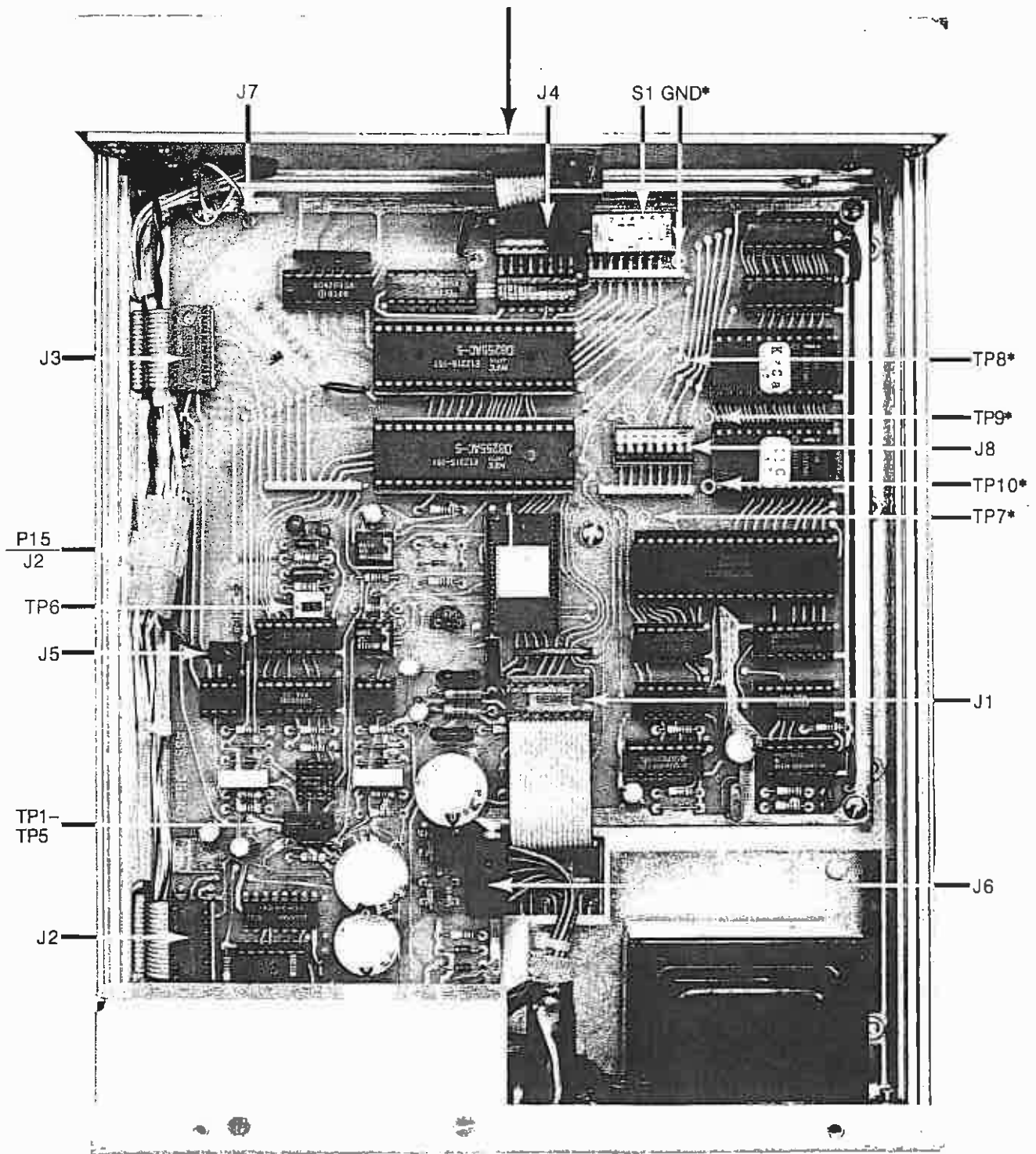

* Not present in early models

Figure 4-1. Model 8210: Top View with Covers Removed

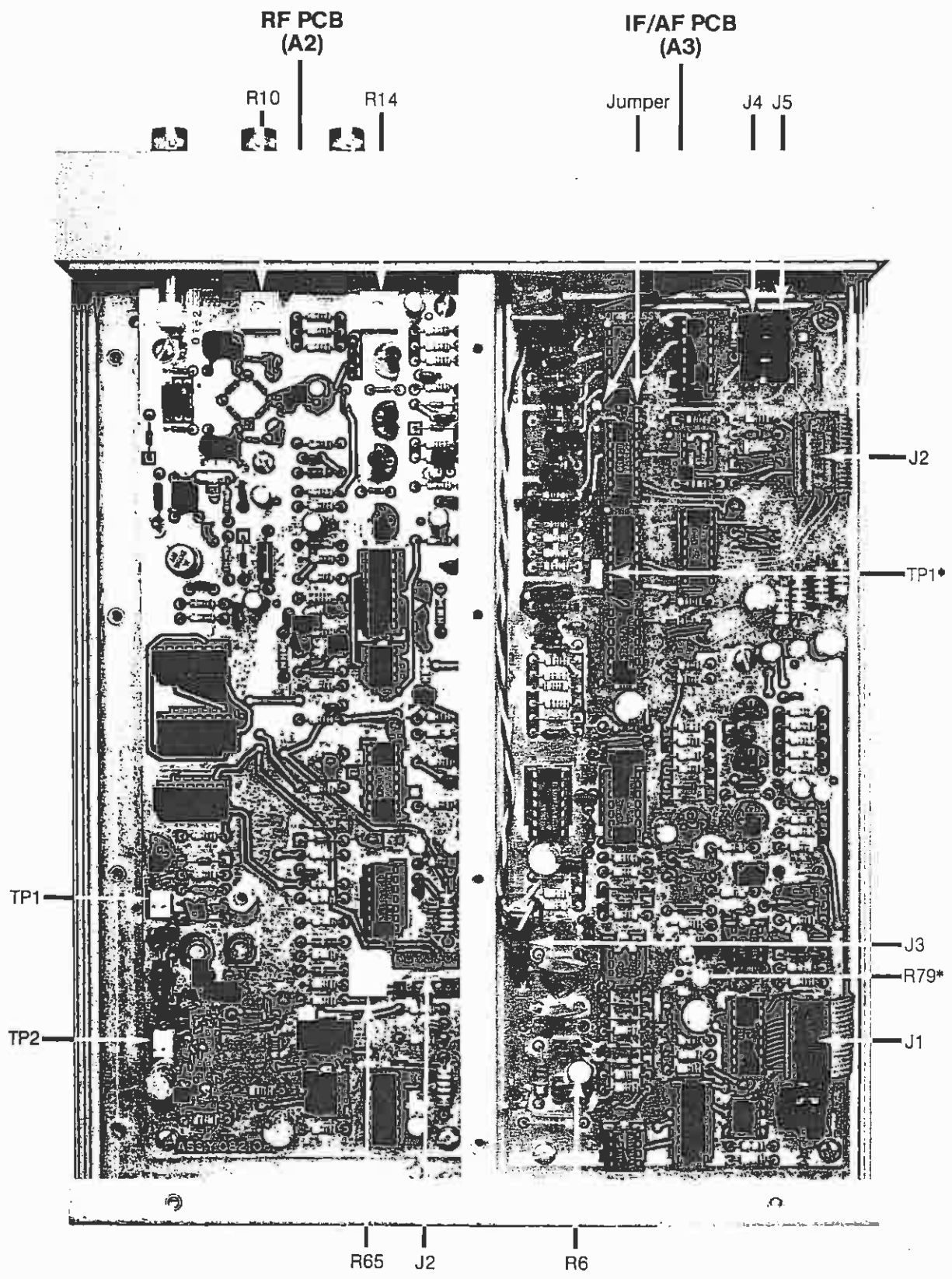

Figure 4-2. Model 8210: Bottom View with Covers Removed

¶4-4a, Continued.

- (3) Remove the cover by lifting up and toward the rear of the unit.
- (4) Turn the instrument over and remove the two #4-40 screws securing the bottom cover.
- (5) Remove the bottom cover as in Step (3).

b. R.F.-Assembly Cover.

- (1) Remove the 8210's covers as in ¶4-4a.
- (2) Place the instrument on a smooth working surface, with the bottom side up.
- (3) Remove the nine #4-40 screws that secure the R.F.-Assembly cover.
- (4) Push the cover toward the rear of the instrument and lift the front of the cover upwards.
- (5) Pull the cover toward the front of the instrument and remove it.

c. R.F. Circuit Board.

- (1) Remove the instrument's covers (¶4-4a).
- (2) Remove the cover of the r.f assembly (¶4-4b).
- (3) Remove the i.f. connection at the r.f. circuit board.
- (4) Turn the instrument over and disconnect ribbon connector AlP4.
- (5) Remove the five #4-40 screws and the one hex standoff securing the circuit board.
- (6) Carefully slide the circuit board toward the rear of the instrument to disengage the r.f. input connector.
- (7) Lift the circuit board out of the instrument.

d. I.F.-A.F. Circuit Board.

- (1) Remove the instrument's covers (¶4-4a).
- (2) Remove the i.f. connection at the rear of the i.f.-a.f. circuit board.
- (3) Disconnect both ribbon connectors on the left edge of the circuit board.
- (4) Disconnect both two-pin connectors at the front edge of the circuit board; disconnect the two-pin connector at the right edge of the circuit board.
- (5) Remove the five #4-40 screws securing the circuit board, and lift out the board.

e. Rear-Panel Assembly.

- (1) Remove the instrument's covers (¶4-4a).
- (2) Disconnect the power connector, AlP14.
- (3) Disconnect the power-switch connector, AlP15.

¶4-4e, Continued.

- (4) Remove three #6-32 screws securing the rear panel to the chassis.
- (5) Remove two #4-40 screws securing the rear panel to the power-supply heat sink.
- (6) Pull the rear panel away from the chassis.

f. Digital Circuits and Power-Supply Board.

- (1) Remove the instrument's covers (¶4-4a).
- (2) Disconnect the four ribbon connectors ALP7, ALP8, ALP9 and ALP11.
- (3) Disconnect pin connector ALP13.
- (4) Disconnect two-pin connector ALP10.
- (5) Remove the rear-panel assembly (¶4-4e).
- (6) Remove seven #4-40 screws securing the circuit board, and lift the board out of the chassis.

g. Display Circuit Board (Access or Removal).

- (1) Remove the instrument's covers (¶4-4a).
- (2) Remove three #4-40 screws securing the top trim-strip extrusions and grounding clip.
- (3) Grasp the trim strip by its edges and pull it away from the instrument's frame.
- (4) Carefully remove the plexiglass display window.
- (5) Turn the instrument over and remove the bottom trim-strip extrusion as in Steps (2) and (3), above.
- (6) Tilt the bottom of the front trim panel away from the instrument until all switches are cleared, then pull the front panel up and out to clear the center trim extrusion.

NOTE: This completes the procedure for gaining access to the Display Circuit board. If it is necessary to remove the board, carry on as follows:

- (7) Disconnect the ribbon-cable connector from the rear of the board.
- (8) Disconnect the power-switch connector, ALP15.
- (9) Disconnect the power-indicator connector, ALP13.
- (10) Remove the two #4 flat-head screws securing the center trim extrusion. Lift out the extrusion.
- (11) Remove the four #4-40 screws securing the circuit board, and lift the board out of the instrument.

4-5. REMOVAL OF DETAIL PARTS

In the design of the 8210, much thought was given to maintainability. Most detail parts are readily available for checking and replacement once the instrument's covers and shields are removed. Solid-state components, on plated-through circuit boards, are used throughout the instrument. Sockets are used for all active components except for the power-supply regulators.

§4-5, Continued.

Standard printed-circuit-board maintenance techniques are required for the removal and replacement of parts. Excessive heat must be avoided; a low-wattage soldering iron, together with suitable heat sinks, should be used for all soldering and unsoldering operations.

4-6. PRELIMINARY CHECKS

a. Visual Check. If equipment malfunction occurs, perform a visual check of the 8210 before performing electrical tests. Visual checks often help to isolate, quickly and simply, the cause of a malfunction. Inspect for signs of damage caused by excessive shock or vibration, such as: broken wires, loose hardware, and loose electrical connections. Then check for signs of overheating, which may be caused by an electrical short-circuit or an accumulation of dirt and other foreign matter.

Correct any problems discovered through the visual check. If the trouble persists, proceed with the electrical checks.

b. Power-Supply Check. Improper operation of the 8210 may be caused by incorrect d.c. operating voltages. Before proceeding with any other electrical checks, perform the power-supply checks given in Table 4-2.

*** WARNING ***

Line voltages up to 240 volts, a.c., may be encountered in the power-supply circuits. To protect against electrical shock, observe suitable precautions when connecting and disconnecting test equipment, and when making voltage measurements.

Table 4-2. Power-Supply Checks

STEP	PROCEDURE	NORMAL INDICATION
1)	Set the LINE switch to ON. Using a digital voltmeter, measure the d.c. voltage at the +15 V supply rail, A4TP5.	14.75 to 15.25 V
2)	Using a digital voltmeter, measure the d.c. voltage at the -15 V supply rail, A4TP2.	-14.75 to -15.25 V
3)	Using a digital voltmeter, measure the d.c. voltage at the +5 V supply rail, A4TP4.	4.90 to 5.10 V
4)	Using a digital voltmeter, measure the d.c. voltage at the -7.5 V supply rail, A4TP3.	-7.33 to -7.68 V
5)	Using a digital voltmeter, measure the d.c. voltage of the +5(L) supply (pin 24, A4U11).	4.75 to 5.25 V
6)	Using an oscilloscope, measure the a.c. ripple at the +15, -15, +5 and -7.5 V supply rails.	Less than 1 mV, peak-to-peak.

In case of abnormal indications, refer to Table 4-11, a systematic troubleshooting chart for the power supplies.

4-7. TROUBLESHOOTING

a. Concepts. Logical trouble-localization involves three major procedures:

- (1) symptomatic troubleshooting, used to localize the cause of a malfunction to a major circuit group;
- (2) systematic troubleshooting within the affected circuit group, used to localize the cause to a specific circuit or stage; and,
- (3) voltage measurements, waveform analysis, or signature analysis--all used to isolate the defective part.

b. Symptomatic Troubleshooting: Discussion. The design of the Model 8210 facilitates symptomatic troubleshooting. Various "condition codes" are displayed both as a guide to proper operation and to localize a malfunction to a major circuit group (see Table 4-3). Moreover, certain circuit groups can be switched in and out of operation by an internal seven-position Test Switch (refer to Table 4-4). With a grasp of the detailed block diagrams (Figures 3-1 through 3-8), and of the function of each position of the Test Switch, along with manipulation of the front-panel controls, the user is well on the path to localizing the cause of a malfunction to one or more of the major circuit groups. In addition, a variety of symptoms is listed in Table 4-5, together with the probable causes of the malfunctions.

c. Systematic Troubleshooting: Discussion. Once you have localized the cause of a malfunction to a major circuit group, refer to the appropriate Systematic Troubleshooting Chart (Tables 4-6 through 4-11). These charts give instructions to help further localize a cause of malfunction to a particular stage or even to the component of that stage likely to be causing the trouble.

d. Measurements and Analyses: Discussion. The 8210 uses both analog and digital circuitry. Tables 4-6 through 4-11, information on the schematic diagrams (Figures 6-1 through 6-7), and waveform data in Table 4-12, are intended to assist in troubleshooting the analog circuits. Frequently this will suffice--without having to look into the digital circuitry. In case the tests in the analog portions have not solved the problem, some of the troubleshooting tables continue with tests (still using an oscilloscope and voltmeter), for the digital portions of the circuits.

However, the digital circuitry of the 8210 uses a microprocessor in a bus-oriented system. In such circuits, d.c.- and a.c.-measuring instruments are not always adequate to isolating problems, and a new technique, called signature analysis, has been developed. The troubleshooting chart for the 8210's logic circuits accordingly has tests that utilize an oscilloscope, and also has tests that call for signature analysis.

A complete discussion of signature analysis is beyond the scope of this manual; however, a brief description will aid in understanding its use in maintenance of the 8210.

Long, complex data streams are present in any microprocessor bus-oriented system. In signature analysis, with the system operating at normal speed, these data streams are compressed into concise, easy-to-interpret readouts (signatures) measured at pertinent data nodes. By choosing the appropriate measuring periods, or windows, signatures become unique: one, and only one signature occurs at any given node of the instrument in normal operation.

Using a test device known as a signature analyzer you can therefore proceed through the instrument in an orderly fashion: you compare the signature you find at each specified node to the signature that the instrument's manufacturer tells you ought to be at that node, until an improper signature is obtained. Generally, at that point it is possible for you to deduce which component is the most probable cause of the malfunction.

Table 4-3. Condition-Code Displays

DISPLAY	MEANING
CAL	Instrument in calibration (takes approximately 30 seconds).
cc1	8210 has failed to calibrate properly the a.m. channel.
cc2	8210 has failed to calibrate properly the f.m. channel.
----	8210 is unlocked, due to improper r.f.-input frequency or level or to a malfunction in the r.f. circuits.
--	8210 is in unlevelled state, due to low modulation frequency or to a malfunction in the i.f. circuits.
IFLO	R.F. input too low in amplitude, or there is a malfunction in the r.f. circuits.
IFHI	R.F. input too high in amplitude, or there is a malfunction in the r.f., i.f., or a.f. circuits.
dSP	The panel meter is over-ranged.

Table 4-4. Troubleshooting Test-Switch Chart

SWITCH POSITION	FUNCTION	AID IN TROUBLESHOOTING THE FOLLOWING CIRCUITS
1	Disables the automatic frequency-lock loop.	a) Oscillator b) Band-switching c) Attenuator d) Discriminator e) Integrator f) Logic
2	Disables the automatic gain control loop.	a) Automatic gain control b) Logic
3	Disables the frequency-control loop and the auto-zero circuit.	a) Audio b) Peak Detector c) Voltmeter
4	Operates data-acquisition circuits in an endless loop.	a) Voltmeter b) Logic

Table 4-4. Troubleshooting Test-Switch Chart (Continued)

SWITCH POSITION	FUNCTION	AID IN TROUBLESHOOTING THE FOLLOWING CIRCUITS
5	LED test: enables the display (lights all segments), decimal points & annunciators.	a) Logic; ports A, B, & C of U17 and associated buffers. b) Display circuit-board assembly.
5 Plus LEVEL	Tests I/O port of U16. Loads three output ports with hex 55 or hex AA, depending upon PEAK setting.	a) Logic; ports A, B, & C of U16--used for logic control of r.f., i.f., a.f. and calibrator circuits.
6	8210 displays month and year of the installed program.	a) Facilitates testing (signature analysis) of special or updated versions. b) Aids in ordering correct spare PROM's.
7	Operates calibrator circuits in an endless loop.	a) Calibrator b) I.F. c) A.F.

Table 4-5. Symptomatic Troubleshooting Chart

SYMPTOM	PROBABLE CAUSE OF MALFUNCTION
After power-on, instrument fails to display CAL.	One of the Test Switches (A4S1) is on; or defective logic circuits (refer to Table 4-9).
During calibration cycle, 8210 displays CCL.	Defective calibrator circuits (see Table 4-10); or defective i.f. circuits (refer to Table 4-7).
During calibration cycle, 8210 displays CC2.	Defective i.f. circuits (refer to Table 4-7).
The 8210 fails to exit from CAL mode.	Defective logic circuits (refer to Table 4-9).
Instrument fails to lock.	Defective r.f. circuits (Table 4-6).
8210 locks but fails to level properly.	Defective i.f. circuits (refer to Table 4-7).
8210 displays IFLO when proper signal is applied to RF IN.	Defective i.f. circuits (refer to Table 4-7).
8210 displays IFHI when proper signal is applied to RF IN.	Defective i.f. circuits (refer to Table 4-7).

Table 4-5. Symptomatic Troubleshooting Chart (Continued)

SYMPTOM	PROBABLE CAUSE OF MALFUNCTION
A.M. incorrect or inoperative.	Defective r.f. circuits (Table 4-6); defective a.f. circuits (Table 4-8).
F.M. incorrect or inoperative.	Defective a.f. circuits (Table 4-8).
One or more low-pass filters inoperative.	Defective a.f. circuits (refer to Table 4-8).
One or more peak indications incorrect.	Defective a.f. circuits (refer to Table 4-8).
One or more panel switches inoperative.	Defective logic circuits (refer to Table 4-9).
One or more switch annunciators inoperative.	Defective logic circuits (refer to Table 4-9).
All digital panel-meter displays incorrect or inoperative.	Defective logic circuits (refer to Table 4-9).
8210 does not range properly.	Defective a.f. circuits (Table 4-8).
A.F. output missing or incorrect.	Defective a.f. circuits (Table 4-8).
I.F. output missing or incorrect.	Defective i.f. circuits (Table 4-7).

Table 4-6. Systematic Troubleshooting Chart: R.F. Circuits

STEP	PROCEDURE	INDICATION	IF INDICATION IS ABNORMAL
• OSCILLATOR CIRCUITS •			
1)	Power off. Set Test Switch (A4S1) Pos. #1 to "on." Remove r.f. cover & turn power on. Connect 'scope to A2TP1.	R.F. signal between 26 & 38 MHz, > 1 V, p-p.	Isolate defective component in oscillator circuit A2Q8 - A2CR10.
2)	Connect 'scope to collector of A2Q7.	TTL signal between 26 & 38 MHz.	Replace A2Q7 or A2CR7.
3)	Connect 'scope to pin 8 of IC A2U3d.	TTL signal between 26 & 38 MHz.	Replace A2U3.
4)	Connect 'scope to pin 9 of A2U1.	TTL signal between 13 & 19 MHz.	Replace A2U1.
5)	Connect 'scope to pin 3 of A2U1. Depress +PEAK button.	TTL signal, approx. 4 MHz.	Replace A2U2, A2U3; or malfunction in logic circuits (Steps 28-33).
6)	Depress 3 kHz button	TTL signal; frequency should decrease.	Same as in Step 5.

Table 4-6. Systematic Troubleshooting Chart: R.F. Circuits (Continued)

STEP	PROCEDURE	INDICATION	IF INDICATION IS ABNORMAL
● OSCILLATOR CIRCUITS (CONTINUED) ●			
7)	Depress the 750 μ s button.	TTL signal; frequency should decrease.	Same as in Step 5.
8)	Connect 'scope to pin 6 of A2U1.	See Waveform 1, in Table 4-12.	Replace A2U1; or check for open A2R13, A2C15.
● PULSE GENERATOR ●			
9)	Connect 'scope to collector of A2Q1.	See Waveform 2, in Table 4-12.	Check for open A2CR1, A2Q1, A2R1; or replace A2T1 or A2CR3.
10)	Connect 'scope to junction of A2R8 and A2C7.	See Waveform 3, in Table 4-12.	Check for open A2C7, A2R8, A2R9, A2R20; or replace A2T2 or A2CR4.
11)	Connect 'scope to junction of A2C14 and A2R19.	Same as in Step 10, but with reversed polarity.	Check for open A2C14, A2R19.
● R.F. INPUT, SAMPLER, AND SAMPLING AMPLIFIER ●			
12)	Connect 'scope to junction of A2R12 and A2CR2b. Connect a 2.4 MHz, +7 dBm signal to RF IN connector.	2.4 MHz signal, approximately 1.4 V, peak-to-peak.	Check for open A2C3 or A2R3.
13)	Connect 'scope to junction of A2C23 and A2R32. Depress the 750 μ s button.	Approximately 400 kHz, 1.4 V, p-p, with a 2.8 MHz signal added. See Waveform 4, in Table 4-12.	Isolate defective component in sampler or sampling amplifier by d.c. voltage and waveform measurements.
14)	Connect 'scope to pin 1, A2U4.	Approximately 5 V, d.c.	Defective 16-conductor ribbon cable W4 (or pin connections); or defective A2U4; or malfunction in logic circuit (Table 4-9).
15)	Connect 'scope to pin 6 of A2U5. Depress 10 RANGE button.	Approximately 400 kHz, with a 2.8 MHz signal added; approximately 600 mV, peak-to-peak.	Replace A2U5 or A2U4; refer to Table 4-9.
● AUTOMATIC FREQUENCY-LOCK-LOOP CIRCUITS ●			
16)	Connect 'scope to pin 8 of A2U4. Depress the 750 μ s and the +PEAK buttons.	Approximately 5 V, d.c.	Check for open pin 4 in 16-conductor ribbon cable W4; or replace A2U4; or refer to Steps 34-39.

Table 4-6. Systematic Troubleshooting Chart: R.F. Circuits (Continued)

STEP	PROCEDURE	INDICATION	IF INDICATION IS ABNORMAL
• AUTOMATIC FREQUENCY-LOCK-LOOP CIRCUITS (CONTINUED) •			
17)	Connect 'scope to junction of A2L9 & A2R53. Depress the 100 RANGE pushbutton.	300 to 500 kHz, with a 2.8 MHz signal added; approximately 2.5 V, peak-to-peak.	Check A2L6 or A2L9 for open circuit; or bad A2U4.
18)	Depress the 3 kHz button.	Very small residual of signal in Step 17.	Replace A2U4, or see Table 4-9.
19)	Connect 'scope to junction of A2L10 & A2R55. Change frequency of generator to about 2.9 MHz.	300 to 600 kHz, with a 3.3 MHz signal added; approximately 2.5 V, peak-to-peak.	Check A2L7 or A2L10 for open circuit; or bad A2U4.
20)	Connect 'scope to pin 14 of A2U8.	Same as Step 19, but attenuated by 20 dB.	Check for open A2C48.
21)	Connect 'scope to pin 8 of A2U8. Set generator frequency to 2.4 MHz. Depress the 750 μ s button.	300 to 500 kHz square wave, about 3.5 V, p-p, on top of approx. 12 V, d.c.	Check A2CR12 for short circuit; or replace A2U8.
22)	Connect 'scope to pin 3 of A2U9. Set i.f. to about 400 kHz by varying generator's frequency above or below 2.4 MHz.	400 kHz square wave, approximately -0.5 to +2 volts.	Check for open A2C57, A2CR12, A2CR11; or replace A2U9.
23)	Connect 'scope to pin 6 of A2U9.	TTL signal, with pulse about 2.5 μ s wide.	Check for open A2R70, A2C58; or replace A2U9.
24)	Connect 'scope to pin 7 of A26U. Depress -PEAK button.	400 kHz square wave, approximately 5.5 V, peak-to-peak.	Check for open A2R65. Replace A2U6. Refer to Steps 34-39.
25)	Connect 'scope to pin 1 of A2U6. Depress the 3 kHz and +PEAK buttons.	0 volts, d.c., approx.	Replace A2U7 or A2U6; check for open A2R51. Refer to Steps 34-39.
26)	Depress the -PEAK & 750 μ s buttons. Vary generator's frequency about 50 kHz above & below the initial setting.	A.C. ripple < 400 mV, p-p. D.C. voltage will move below & above the baseline as the frequency of the r.f signal is changed.	Check for open A2C47. Replace A2U7. Refer to Steps 34-39.
27)	Reset generator's frequency for 0 V at pin 1 of A2U6. Press the AVG button. Offset the generator frequency by 100 kHz.	Initially, 0 V, d.c., then slowly drifting to approximately \pm 2.4 volts, d.c.	Defective A2C47; or replace A2U7 or A2U6. Refer to Steps 34-39.

Table 4-6. Systematic Troubleshooting Chart: R.F. Circuits (Continued)

STEP	PROCEDURE	INDICATION	IF INDICATION IS ABNORMAL
• DIGITAL PORTION: OSCILLATOR BANDSWITCHING •			
28)	Connect 'scope to pin 2 of A2U3. Depress 15 kHz button.	5 volts, d.c.	Repair or replace W4 cable, or refer to Table 4-9.
29)	Depress the 3 kHz filter button.	0 volts, d.c.	Same as Step 28.
30)	Depress the 750 μ s filter button.	5 volts, d.c.	Same as Step 28.
31)	Connect 'scope to pin 4 of A2U3. Depress 15 kHz button.	0 volts, d.c.	Same as Step 28 or replace defective A2U4.
32)	Depress the 3 kHz filter button.	0 volts, d.c.	Same as Step 31.
33)	Depress the 750 μ s filter button.	5 volts, d.c.	Same as Step 31.
• DIGITAL PORTION: AUTOMATIC FREQUENCY-LOCK-LOOP SWITCHING LOGIC •			
34)	Connect 'scope to pin 10 of A2U7. Depress +PEAK button.	5 volts, d.c.	Check for open circuit in W4 cable; replace A2U7; or check malfunction in logic circuits (see Table 4-9).
35)	Depress the -PEAK button.	0 volts, d.c.	W4 cable may have a short circuit; or look for malfunction in the logic circuits (see Table 4-9).
36)	Depress AVG button.	0 volts, d.c.	Same as Step 34 or 35.
37)	Connect 'scope to pin 11 of A2U7.	0 volts, d.c.	Same as Step 34 or 35.
38)	Depress the -PEAK button.	5 volts, d.c.	Same as Step 34 or 35.
39)	Depress the +PEAK button.	0 volts, d.c.	Same as Step 34 or 35.

Table 4-7. Systematic Troubleshooting Chart: I.F. Circuits

STEP	PROCEDURE	INDICATION	IF INDICATION IS ABNORMAL
1)	Power off. Set Test Switch (A4S1) Pos. #7 "on." Power on. Do NOT press LEVEL button.		
2)	Connect 'scope to pin 3 of A3U1. Depress the AM button.	447.4 kHz sine wave, approximately 1.9 V, peak-to-peak.	Open pin 15 in W5, the 16-conductor ribbon cable; or malfunction in calibrator circuits (see Table 4-10, Steps 1 through 9).
3)	Connect 'scope to pin 6 of A3U1.	Same as Step 2, but doubled in amplitude.	Replace A3U1.
4)	Connect 'scope to pin 1 or pin 16 of A3U3.	874 Hz TTL signal.	Open pin 13 in the W5 cable; or check for a malfunction in calibrator circuits (Table 4-10, Steps 2 and 5).
5)	Depress FM button.	TTL logic 1.	Malfunction in calibrator circuits (see Table 4-10, Step 8).
6)	Depress AM button. Connect 'scope to pin 6 of A3U3.	447 kHz sine wave, audio-modulated at an 874 Hz rate; 1.15 V, p-p. See Waveform 5, Table 4-12.	Check for defective A3R7a through A3R7c; or defective A3U3.
7)	Connect 'scope in turn to pins 5 through 12 of A3U4.	On pin 6, a TTL high; on all others, TTL low.	Defective W5 cable; or malfunction in logic circuits (Table 4-9)
8)	Connect 'scope to pin 4 of A3U4.	Same waveform as in Step 6; approximately 540 mV, p-p. (Depends upon setting of A3R79.)	Isolate defective component by voltage or waveform measurements. Check for open A3CR13, A3C4, A3C5, A3C6, A3R79; or replace A3U4.
9)	Connect 'scope to pin 6 of A3U5.	Same as Step 6, but amplified to approx. 2.85 V, peak-to-peak.	Isolate defective component by voltage or waveform measurements.
10)	Connect 'scope to the junction of A3C23 and A3CR6.	Same as Step 6, but amplified to approx. 5.7 V, peak-to-peak.	Isolate defective component by voltage or waveform measurements. Check for open A3C19, A3C22, A3C18, A3CR6, or A3CR7.
11)	Connect 'scope to the junction of A3CR7 and A3R41.	The above waveform, half-wave rectified; 2.3 V, p-p. See Waveform 6, Table 4-12.	Same as Step 10.

Table 4-7. Systematic Troubleshooting Chart: I.F. Circuits (Continued)

STEP	PROCEDURE	INDICATION	IF INDICATION IS ABNORMAL
12)	Connect 'scope to pin 11 of A3U10.	5 volts, d.c.	Defective 16-conductor ribbon cable W6 (or pin connections); or malfunction in logic circuits (Table 4-9).
13)	Connect 'scope to pin 8 of A3U9.	874 Hz square wave & added 447 kHz sawtooth; about 1.3 V, p-p. See Waveform 7, Table 4-12.	Defective A3C27, A3R47; or replace A3U9.
14)	Connect 'scope to pin 3 of A3U10.	Same as Step 13.	Replace defective A3U10.
15)	Connect 'scope to pin 6 of A3U8.	Same as Step 9.	Defective A3U8; "short" in A3CR9 or A3CR10.
16)	Connect 'scope to IF OUT connector.	Same as Step 9.	Defective A1P1, A1W1, or A1J3.
17)	Connect 'scope to collector of A3Q1; Set time-base of 'scope to 1 μ s/div.	447 kHz TTL signal. See Waveform 8 in Table 4-12.	Isolate defective component by voltage or waveform measurements. Suspect A3Q1, A3Q2, A3CR3, A3CR4, or A3CR5.
18)	Connect 'scope to pin 1 of A3U7. Time-base at 0.5 μ s/div.	A pulse: width about 2.1 to 2.4 μ s; amplitude 5 V, p-p.	Width: check timing components A3C20, A3R33; or replace A3U7. Amplitude: check A3R43 through A3R46.
19)	Connect 'scope to pin 13 of A3U10. Depress FM pushbutton.	447 kHz sawtooth; -0.5 to -2 volts, p-p.	Isolate defective component by voltage or waveform measurements. Check for open A3C28; or bad logic circuits (see Table 4-9).
20)	Set Test-Switch Pos. #7 "off," #2 "on." Power "off," then "on."	12.8 appears on the front-panel display.	Malfunction in logic circuits (Table 4-9).
21)	Connect 'scope to junction of A4R20 & A4C15; set for d.c. and V. Sensitivity @ 0.05 V per div. Hold depressed -PEAK button until 8210 displays 1.9 or 2.0.	Approximately 0.25 V, d.c.	Open A3R77; or defect in A1P5, A1W5, A1P8, A4R20, A4C15 or A4U20.
22)	Adjust V. Position on 'scope so trace nears bottom of screen. Hold depressed +PEAK pushbutton of 8210.	Rise in d.c. voltage should be smooth (no "steps"), to about 3.5 V, d.c.	Defective A3J1, A1P5, A1W5, A1P8, A4J2, or A3U4; or defective logic circuits (see Table 4-9).

Table 4-7. Systematic Troubleshooting Chart: I.F. Circuits (Continued)

STEP	PROCEDURE	INDICATION	IF INDICATION IS ABNORMAL
23)	Set Pos. #2 on Test Switch (A4S1) "off." Turn power off, then on. Allow completion of the calibration cycle. To RF IN apply a 30 MHz, -10 dBm signal with 50% 1 kHz a.m. Connect the 'scope to the junction of A3L3 and A3R3.	400 kHz sine wave with a.m.; amplitude approx. 0.82 V, peak-to-peak.	Problem in the i.f. filter circuit. Use waveform measurements to isolate the problem.
24)	Connect 'scope to pin 6 of A3U2.	Same as Step 23, but amplitude increased to about 3.5 V, p-p.	Isolate defective component in circuit of input amplifier, using voltage and waveform measurements.
25)	Connect 'scope to pin 8 or 9 of A3U3.	A TTL high.	Defective 16-conductor ribbon cable W5 (or pin connections); or malfunction in logic circuits (Table 4-9); or replace defective A3U3.
26)	Connect 'scope to pin 6 or 11 of A3U3.	A TTL low.	
27)	Increase level of generator to more than +13 dBm.	Display shows IFHI.	Defect in circuits of: a.f. (see Table 4-8); r.f. (Table 4-6); or logic (Table 4-9).
28)	Reduce generator's level to -40 dBm.	Display shows IFLO.	Same as Step 27.

Table 4-8. Systematic Troubleshooting Chart: A.F. Circuits

STEP	PROCEDURE	INDICATION	IF INDICATION IS ABNORMAL
1)	(a) Power "off." (b) Disconnect A1P1 from A3J3 and connect it to A3TP1.* (c) Remove A3U10. (d) Set Pos. #3 on Test Switch (A4S1) to "on." (e) Set a.f. oscillator for 1 kHz, 106 mV, r.m.s. (f) Apply the a.f. signal to the IF OUT connector (A1J3). (g) Turn power "on." *Early 8210's do not have A3TP1. On these, omit (b), and change (f) as follows: Apply the a.f. signal to pin 3 of the A3U10 socket. Other steps unchanged.		
NOTE: "INDICATIONS" in this Table are approximate.			
2)	Depress the front-panel 10 RANGE push-button. Connect 'scope to pin 13 of A3U11.	1 kHz sine wave; 300 mV, peak-to-peak.	Isolate defective component in the filter circuit A3U9c by waveform measurements. See also Steps 33 - 40.

Table 4-8. Systematic Troubleshooting Chart: A.F. Circuits (Continued)

STEP	PROCEDURE	INDICATION	IF INDICATION IS ABNORMAL
3)	Set a.f. oscillator to about 72 kHz.	72 kHz sine wave; 210 mV (approx.), p-p	Same as Step 2.
4)	Set a.f. oscillator to 1 kHz. Connect 'scope to pin 3, A3U11.	1 kHz sine wave; 300 mV, peak-to-peak.	Defective A3U11; or see Steps 33 - 40.
5)	Depress 100 RANGE pushbutton.	As above, amplitude reduced by 20 dB ($\times 0.1$).	As above; also check for defective A3R59.
6)	Depress 10 RANGE. Connect 'scope to pin 14 of A3U9.	1 kHz sine wave; 3.3 V, peak-to-peak.	Replace A3U9, A3R61, or A3R63. Check for open decoupling capacitors.
7)	Connect 'scope to pin 12 of A3U13.	Same as Step 6.	Isolate defective component in A3U12a circuit; or defective A3U12, A3U13.
8)	Set a.f. oscillator to 5 kHz.	5 kHz sine wave; 3.3 V, peak-to-peak.	Same as Step 7.
9)	Set a.f. oscillator to 15.00 kHz.	15 kHz sine wave; 2.25 to 2.41 V, p-p.	Check A3R71 or A3C47.
10)	Set a.f. oscillator to 750 Hz. Connect 'scope to pin 14, A3U13.	750 Hz sine wave; 3.3 volts, peak-to-peak.	Isolate defective component in A3U12b circuit; or defective A3U12, A3U13.
11)	Set a.f. oscillator to 3.00 kHz.	3 kHz sine wave; 2.25 to 2.41 V, p-p.	Check for defective A3R68 or A3C44.
12)	Set a.f. oscillator to 50 Hz. Connect 'scope to pin 15, A3U13.	50 Hz sine wave; 3.3 volts, peak-to-peak.	Check for defective A3R69, or A3C45.
13)	Set a.f. oscillator to 212 Hz.	212 Hz sine wave; 2.25 to 2.41 V, p-p.	Same as Step 12.
14)	Set a.f. oscillator 5.00 kHz. Connect 'scope to pin 11, A3U13.	5 kHz sine wave; 2.2 volts, peak-to-peak.	Check for open/shorted capacitor, or open resistor. Check A3U13.
15)	Perform tests given in Steps 38 and 39.		
16)	Set a.f. oscillator to 1 kHz. Depress 8210's 15 kHz button. Connect 'scope to A3J4.	1 kHz undistorted waveform; 8.38 volts, peak-to-peak.	Isolate defective component, by voltage and waveform measurements, in A3U14 circuit.
17)	Connect 'scope to pin 3 of A3U15. Depress 3 kHz button.	1 kHz sine wave, square-wave modulated; 3.3 V, peak-to-peak.	Isolate bad component, in A3U12-A3U15 circuit, by waveform measurements. See Step 40.

Table 4-8. Systematic Troubleshooting Chart: A.F. Circuits (Continued)

STEP	PROCEDURE	INDICATION	IF INDICATION IS ABNORMAL
18)	Connect 'scope to A3J5. Depress the button labeled 750 μ s.	Same as Step 17, but approximately 670 mV, peak-to-peak.	Defective A3U12, or shorted two-conductor cable W7.
19)	Connect 'scope to AF OUT. Depress the button labeled 15 kHz.	Same as Step 16.	Defective A1P2, A1W2, or A1J4.
20)	Connect 'scope to A4J5.	Same as Step 17.	Repair or Replace W7 (two-conductor cable).
21)	Connect 'scope to pin 10 of A4U22.	5 volt logic signal.	Malfunction in logic circuits (Table 4-9).
22)	With a 2nd 'scope probe, connect to pin 6, A4U23 (see Table 4-12, Fig.9, for 'scope settings). Connect r.m.s. voltmeter to AF OUT. Set a.f. oscillator to 50 Hz & adjust output for 2 V, r.m.s., on VM.	See Waveform 9 in Table 4-12.	Isolate defective components by waveform measurements. Suspect A4U22, A4U21, A4U23, or open A4CR4, A4CR6.
23)	Connect probe B to pin 6, A4U24. See Table 4-12, Fig.10, for 'scope settings.	See Waveform 10 in Table 4-12.	Isolate defective component by waveform measurements. Suspect A4U22, A4U21, A4U24, or open A4CR5, A4CR7.
24)	Connect probe B to pin 3, A4U20.	See Waveform 11 in Table 4-12.	Defective A4U20; or malfunction in logic circuits (Table 4-9).
• VOLTMETER SECTION •			
25)	Power off. Set Test Switch Pos.#4 "on." Power on. "Short" pins 1 and 2 of A4TP6.		
26)	Check the logic on pins 9, 10 & 11 of A4U20.	All high.	Malfunction in logic circuits. See Table 4-9, Steps 49 and 50.
27)	Connect d.c. voltmeter to junction of A4R20 and A4C15.	Indicated d.c. voltage should be approx. 1 V.	Check for open circuit at pin 2 of cable W6 (16-conductor cable).
28)	Move VM probe to pin 3 of A4U20.	Same as Step 27.	Replace defective A4U20.
29)	Move VM probe to pin 6 of A4U2.	Indicated d.c. voltage 2.4 to 2.47 volts.	Replace defective A4U2.

Table 4-8. Systematic Troubleshooting Chart: A.F. Circuits (Continued)

STEP	PROCEDURE	INDICATION	IF INDICATION IS ABNORMAL
● VOLTMETER SECTION (CONTINUED) ●			
30)	Connect 'scope to pin 6, A4U6. Adjust trigger level of 'scope for stationary display.	TTL signal; period approximately 1.5 μ s.	Malfunction in logic circuits. Replace defective A4U6 or A4Q4.
31)	Connect 'scope to collector of A4Q4. Adjust trigger level for stationary display.	Similar to Step 30, but signal swings from +12 to +14 volts.	Replace defective A4Q4 or A4U4.
32)	Set 'scope for d.c., V. Sens.@ 0.2 V/div. & 0.05 μ s/div. Connect probe to pin 2 of A4U4. Set trigger level for a stationary display.	Approximately 0.6 V, d.c.	Check for open diode A4CR2, or malfunction in logic circuits (see Table 4-9, Steps 1-14); or replace A4U4 or A4U7.
33)	Remove short from pins 1 & 2, A4TP6.	D.C. voltage will go negative.	Same as Step 32.
● DIGITAL PORTION: A.F. CIRCUITS ●			
34)	Connect 'scope to pin 11 of A3U10. Depress the FM FUNCTION pushbutton.	CMOS low.	Defective A3J2, A1P6, A1W6, A1P9; or logic-circuit malfunction (refer to Table 4-9).
35)	Depress the AM FUNCTION pushbutton.	CMOS high.	Same as Step 34, or defective A3U10.
36)	Connect 'scope to pin 11, A3U11. Depress 100 RANGE button.	CMOS high.	Same as Step 34, or defective A3U11.
37)	Depress 10 RANGE.	CMOS low.	Same as Step 34.
38)	Connect 'scope to pin 10, A3U11. Power off, then on, quickly.	Normal CMOS "low" will move toward "high" as power is switched on.	Same as Step 36.
39)	Connect 'scope to pin 10 of A3U13. Depress, in turn: 15 kHz pushbutton; 3 kHz pushbutton; 750 μ s pushbutton.	CMOS low. CMOS high. CMOS low.	Same as Step 34. As above, or bad A3U13. Same as Step 34.
40)	Connect 'scope to pin 9 of A3U13. Depress, in turn: 15 kHz pushbutton; 3 kHz pushbutton; 750 μ s pushbutton.	CMOS low. CMOS low. CMOS high.	Same as Step 34. Same as Step 34. As above, or bad A3U13.
41)	Connect 'scope to pin 9 of A3U15.	CMOS logic signal.	Same as Step 34, or defective A3U15.

Table 4-9. Systematic Troubleshooting Chart: Logic Circuits

STEP	PROCEDURE	INDICATION	IF INDICATION IS ABNORMAL
1)	Connect 'scope to pin 10 of A4U1.	3.579 MHz TTL logic signal.	Replace A4U1, A4Y1, or A4C2.
2)	Connect 'scope to pin 8 of A4U1.	Same as Step 1.	Replace A4U5.
3)	Connect 'scope to pin 6 of A4U8.	1.789 MHz TTL signal.	Replace A4U5 or A4U9.
4)	Connect 'scope to pin 1 of A4U3.	Approximately 874 Hz CMOS logic signal.	Replace A4U3.
5)	Connect 'scope to pin 6 of A4U3.	447.35 kHz CMOS logic signal.	Replace A4U3 or A4U12.
6)	Connect 'scope to pin 26 of A4U8.	TTL high.	Replace A4U1, or check for shorted A4C1.
7)	Power off. Remove jumper A4J8. Connect signature analyzer per Table 4-9a. Power on. Run signature-analysis test of the address bus.	See Table 4-9a.	Defective A4U8, or a "short" in circuitry.
8)	Connect 'scope in turn to data bus lines D0 - D7 of A4U8.	TTL signals on all lines.	Same as Step 7.
9)	Connect 'scope in turn to remaining pins of A4U8.	TTL signals on pins 19, 21, 27 & 28. Pins 17, 18, 20, 22, 24 and 25 are TTL high.	Same as Step 7.
10)	Connect 'scope to pin 8 of A4U6.	TTL logic signal	Defective A4U6, or a "short" in circuitry.
11)	Connect signature analyzer per Table 4-9b and run test on the decoder: A4U10.	See Table 4-9b.	Defective A4U10, or a "short" in circuitry.
12)	Connect signature analyzer per Table 4-9c; test PROM A4U11.	See Table 4-9c.	Defective A4U11, or a "short" in circuitry.
13)	Connect signature analyzer per Table 4-9c; test PROM A4U13.	See Table 4-9c.	Defective A4U13, or a "short" in circuitry.
14)	Replace jumper A4J8. Connect 'scope to pin 18 of A4U8.	TTL high.	Replace A4U14 or A4U15, or both, or A4U6.
15)	Connect 'scope to pin 3 of A4U5.	TTL logic signal, about 874 Hz.	Defective A4U1, or a "short" in circuitry.

Table 4-9. Systematic Troubleshooting Chart: Logic Circuits (Continued)

STEP	PROCEDURE	INDICATION	IF INDICATION IS ABNORMAL
16)	Connect 'scope to pin 6 of A4U5.	TTL logic signal, 1.15 ms period.	Replace A4U5, A4U6, or A4U8.
17)	Connect 'scope to pin 6 of A4U6.	TTL logic signal.	Replace A4U6 or A4Q4.
18)	Connect 'scope to pin 8 of A4U6.	TTL logic signal.	Defective A4U6, or a "short" in circuitry.
19)	Connect 'scope to pin 35 of A4U16.	TTL low.	Replace A4U1.
20)	Connect 'scope to pin 35 of A4U17.	TTL low.	Same as Step 19.
21)	Connect 'scope in turn to pins 18 through 22 of A4U17.	TTL logic signal.	Replace A4U17 or A4U18; or check for a "short" in circuitry.
22)	Connect 'scope in turn to pins 11 through 15 of A4U18.	Same as in Step 21.	Defective A4U18, or a "short" in circuitry; or defective A4R16.
23)	Connect 'scope to pin 4 of A4U17.	TTL low.	Defective A4U17, or a "short" in circuitry.
24)	Depress the 15 kHz pushbutton.	See Waveform 12 in Table 4-12.	Check for open circuit: 16-conductor cable W8 (and its connections); also, A4CR8 & A4S8.
25)	Depress the +PEAK pushbutton.	Same as in Step 24.	As above: W8 (etc.), A4CR9, A4S9.
26)	Depress the FM pushbutton.	Same as in Step 24.	As above: W8 (etc.), A4CR10, A4S10.
27)	Depress the 100 RANGE pushbutton.	Same as in Step 24.	As above: W8 (etc.), A4CR11, A4S11.
28)	Connect 'scope to pin 3 of A4U17.	TTL low.	Defective A4U17, or a "short" in circuitry.
29)	Depress the 3 kHz pushbutton.	Same as in Step 24.	Replace A4U17; check for open circuit in W8 (and its connections), or in A4S4.
30)	Depress the -PEAK pushbutton.	Same as in Step 24.	Check for open circuit in W8 (etc.), & A4S5.
31)	Depress the AM pushbutton.	Same as in Step 24.	As above: W8 (etc.), A4S6.
32)	Depress the 10 RANGE pushbutton.	Same as in Step 24.	As above: W8 (etc.), A4S7.

Table 4-9. Systematic Troubleshooting Chart: Logic Circuits (Continued)

STEP	PROCEDURE	INDICATION	IF INDICATION IS ABNORMAL																
33)	Connect 'scope to pin 2 of A4U17.	TTL low.	Replace A4U17; check "short" in circuitry.																
34)	Depress the 750 μ s pushbutton.	Same as in Step 24.	Check for open circuit: W8 (etc.), A4S1.																
35)	Depress the AVG pushbutton.	Same as in Step 24.	As above: W8 (etc.), A4S2.																
36)	Depress the LEVEL pushbutton.	Same as in Step 24.	As above: W8 (etc.), A4S3.																
37)	Set "on," one at a time, each position of Test Switch, A4S1; as each one is turned on, connect 'scope in turn to pins 3 through 9 of A4R14.	Same as in Step 24, on each pin, as each Test Switch position is turned "on."	Replace A4U17, A4S1, or A4R14.																
38)	Set Test Switch Pos. #5 to "on." Turn power off, then on.	All display segments and legends "on."	Continue Steps 39 - 43. (If "Indication" is good, jump to Step 44.)																
39)	Connect 'scope in turn to pins 1 through 8 of A4U19.	See Waveform 13 in Table 12.	Replace defective A4U17 or A4U19.																
40)	As above, pins 11 through 18.	See Waveform 14 in Table 4-12.	Defective A4U19, or a "short" in circuitry.																
41)	Connect 'scope in turn to pins 9 through 16 of A5J1.	Same as in Step 40.	Check for "open" in W8 (etc.); or replace LED A4CR2 through A4CR7.																
42)	Connect 'scope in turn to pins 14 of A4SD1, A4SD2, A4SD3, A4SD4.	Same as in Step 24.	Check for open circuit in W8 (etc.).																
43)	Visually inspect display for missing segments or decimal points.	Same as in Step 38.	If the same segment is out on A4SD2 through A4SD4, check for open circuit. If outage is not common, replace faulty display(s).																
44)	Depress the LEVEL pushbutton.																		
45)	Depress the +PEAK button. Connect the 'scope in turn to pins PA0 through PA7, A4U16.	<table border="1"> <tr> <td>A0</td><td>A1</td><td>A2</td><td>A3</td><td>A4</td><td>A5</td><td>A6</td><td>A7</td> </tr> <tr> <td>1</td><td>0</td><td>1</td><td>0</td><td>1</td><td>0</td><td>1</td><td>0</td> </tr> </table>	A0	A1	A2	A3	A4	A5	A6	A7	1	0	1	0	1	0	1	0	Replace A4U16 or A4U10; or check for a "short" in their circuitry.
A0	A1	A2	A3	A4	A5	A6	A7												
1	0	1	0	1	0	1	0												
46)	Depress the -PEAK button. Connect the 'scope in turn to pins PA0 through PA7, A4U16.	<table border="1"> <tr> <td>0</td><td>1</td><td>0</td><td>1</td><td>0</td><td>1</td><td>0</td><td>1</td> </tr> </table>	0	1	0	1	0	1	0	1	Same as in Step 45.								
0	1	0	1	0	1	0	1												

Table 4-9. Systematic Troubleshooting Chart: Logic Circuits (Continued)

STEP	PROCEDURE	INDICATION	IF INDICATION IS ABNORMAL
47)	Connect the 'scope in turn to pins PB0 through PB7 of A4U16.	Same as in Step 46.	Defective A4U16; or a "short" in circuitry.
48)	Depress the +PEAK button. Connect the 'scope in turn to pins PB0 through PB7, A4U16.	Same as in Step 45.	Same as in Step 47.
49)	Connect the 'scope in turn to pins PC0 through PC7 of A4U16.	Same as in Step 45.	Replace A4U16 or A4U20; or check for a "short" in their circuitry.
50)	Depress the -PEAK button. Connect the 'scope in turn to pins PC0 through PC7, A4U16.	Same as in Step 46.	Same as above.
51)	Set Test Switch Pos. #5 "off." Power off. Power on.	Instrument is returned to operating condition.	

Table 4-9a. Signature-Analysis Chart: Address Field

<p>PROCEDURE: Power off. Remove jumper A4J8, located on the Power-Supply-and-Digital-Circuits board. Set the Signature Analyzer's controls, and connect it, as shown below. Turn the 8210 "on".</p>					
<p>SIGNATURE ANALYZER SWITCH SETTINGS & CABLE-CONNECTION POINTS:</p>					
<u>Function</u>	<u>Switch Setting</u>	<u>Cable Connection</u>			
START	┌	Pin 5 of A4U8			
STOP	┐	Pin 20 of A4U7			
CLOCK	└	pin 21 of A4U8			
<p>SIGNATURE ANALYZER PROBE CONNECTIONS:</p>					
<u>Item</u>	<u>Test Point: Pin on A4U8</u>	<u>Correct Signature</u>	<u>Item</u>	<u>Test Point: Pin on A4U8</u>	<u>Correct Signature</u>
Common	29	0000	A7	37	A3C1
V _{cc}	11	755U	A8	38	7707
A0	30	H335	A9	39	577A
A1	31	C113	A10	40	HH86
A2	32	7050	A11	1	89F1
A3	33	0772	A12	2	AC99
A4	34	C4C3	A13	3	PCF3
A5	35	AA08	A14	4	1180
A6	36	7211	A15	5	755U

Table 4-9b. Signature-Analysis Chart: Decoder Circuit

PROCEDURE: Same as in Table 4-9a.					
SIGNATURE ANALYZER SWITCH SETTINGS & CABLE-CONNECTION POINTS:					
<u>Function</u>	<u>Switch Setting</u>	<u>Cable Connection</u>			
START	┌	Pin 5 of A4U8			
STOP	└	Pin 20 of A4U7			
CLOCK	┌	pin 21 of A4U8			
SIGNATURE ANALYZER PROBE CONNECTIONS:					
<u>Item</u>	<u>Test Point: Pin on A4U10</u>	<u>Correct Signature</u>	<u>Item</u>	<u>Test Point: Pin on A4U10</u>	<u>Correct Signature</u>
Common	8	0000	CS2	3	P352
+5 V	16	755U	CS3	5	8UH9
CS0	1	4CP2	CS4	7	F615
CS1	2	ULU2			

Table 4-9c. Signature-Analysis Chart: PROM's A4U11 & A4U13 (Sept., 1982*)

PROCEDURE: Same as in Table 4-9a.					
SIGNATURE ANALYZER SWITCH SETTINGS & CABLE-CONNECTION POINTS:					
<u>Function</u>	<u>Switch Setting</u>	<u>Cable Connection</u>			
		<u>Testing A4U11</u>	<u>Testing A4U13</u>		
START	└	Pin 1 of A4U10	Pin 2 of A4U10		
STOP	┌	Pin 1 of A4U10	Pin 2 of A4U10		
CLOCK	┌	Pin 21 of A4U8	Pin 21 of A4U8		
SIGNATURE ANALYZER PROBE CONNECTIONS:					
<u>Item</u>	<u>Test Point: Pin on A4U11</u>	<u>Correct Signature</u>	<u>Item</u>	<u>Test Point: Pin on A4U13</u>	<u>Correct Signature</u>
Common	12	0000	Common	12	0000
+5 V	24	7A70	+5 V	24	7A70
D0	9	UPU3	D0	9	27F3
D1	10	1POP	D1	10	5011
D2	11	56FP	D2	11	331H
D3	13	0104	D3	13	9P80
D4	14	41C6	D4	14	0A2F
D5	15	1745	D5	15	762C
D6	16	F799	D6	16	7621
D7	17	900U	D7	17	H89F

* To determine date of PROM's: Set Pos. #6 of the Test Switch (A4S1) "on". Turn power off, then on. The date of the PROM's will appear on the 8210's display. Reset the Test Switch (all positions "off").

Table 4-10. Systematic Troubleshooting Chart: Calibrator Circuits

STEP	PROCEDURE	INDICATION	IF INDICATION IS ABNORMAL
1)	Power off. Set Pos. #7 of Test Switch (A4S1) "on." Power on. Depress LEVEL button. Connect 'scope to pin 2 of A4U9.	1.79 MHz TTL logic signal.	Replace A4U9, or bad logic circuits (see Table 4-9).
2)	Connect 'scope to pin 3 of A4U9.	TTL signal, at about 874 Hz.	Replace A4U9 or A4U12; or defective logic circuits (Table 4-9).
3)	Connect 'scope to pin 9 of A4U9.	TTL signal, switching from 357.9 to 447.4 kHz at an 874 Hz rate.	Replace A4U9.
4)	Connect 'scope to pin 4 of A4U12.	TTL signal, 447.4 kHz.	Replace A4U12, or bad logic circuits (see Table 4-9).
5)	Connect 'scope to pin 12 of A4U12.	TTL signal, 874 Hz.	Same as in Step 2.
6)	Connect 'scope to pin 7 of A4U12. Depress the AM button.	TTL signal, 447.4 kHz.	Replace A4U12, or bad logic circuits (Table 4-9, Steps 44 - 50).
7)	Connect 'scope to pin 9 of A4U12.	TTL signal, 874 Hz.	Same as in Step 6.
8)	Depress FM button.	TTL high.	Same as in Step 6.
9)	Connect 'scope to pin 3 of A3U1. Depress the AM button.	Sine wave, 447.4 kHz; approximately 1.9 V, peak-to-peak.	Check for open A4L1, A4L2, A4C8, A4C10, A4C11, or 16-conductor cable W5 (or its connections); or replace defective A3U1.
10)	Connect 'scope to pin 6 of A3U1.	Same as in Step 9, but doubled in amplitude.	Replace defective A3U1.
11)	Connect 'scope to IF OUT connector.	See Waveform 15, Table 4-12.	Bad i.f. circuits. Refer to Table 4-7, Steps 4 through 9, and 15.
12)	Depress FM button	See Waveform 16, Table 4-12.	Replace A4U9; or bad i.f. circuits (see Table 4-7).
13)	Connect 'scope to AF OUT connector. Depress the AM button.	874 Hz, 2.5 V, p-p. See Waveform 17, Table 4-12.	Bad i.f. circuits (refer to Table 4-7, Steps 4 through 10); or bad a.f. circuits (refer to Table 4-8, Steps 1 through 6, and 14 through 16).

Table 4-11. Systematic Troubleshooting Chart: Power Supply

STEP	PROCEDURE	INDICATION	IF INDICATION IS ABNORMAL
	(Line Voltage = 120)		
1)	Connect 'scope to the junction of A4CR8 and A4C23.	8.55 to 9.45 V, d.c.; ripple approximately 350 mV, peak-to-peak.	Isolate defective component by voltage or waveform measurements.
2)	Connect 'scope to the junction of A4CR9 and A4C24.	19.0 to 21.0 V; ripple approximately 350 mV, peak-to-peak.	Same as above.
3)	Connect 'scope to the junction of A4CR9 & A4C25.	-19 to -21 V; ripple approximately 800 mV, peak-to-peak.	Same as above.
4)	Connect voltmeter to pin 4, 6, or 8 of A4U7.	9.9 to 10.1 V, d.c.	Check A4C34 for short circuit; or defective A4U29, A4U7.
5)	Connect VM & 'scope to the junction of A4CR18 and A4C35.	14.75 to 15.25 V; ripple less than 1 mV, peak-to-peak.	Isolate defective component by voltage measurements.
6)	Connect VM & 'scope to the junction of A4CR19 and A4C36.	-14.75 to -15.25 V; ripple less than 1 mV, peak-to-peak.	Same as Step 5.
7)	Connect VM & 'scope to pin 7 of A4U29.	7.33 to 7.68 V; ripple less than 1 mV, peak-to-peak.	Same as Step 5.
8)	Connect VM & 'scope to the junction of A4CR15 and A4C33.	4.75 to 5.25 V; ripple less than 1 mV, peak-to-peak.	Same as Step 5.
9)	Connect VM & 'scope to the junction of A4CR17 and A4C32.	4.90 to 5.10 V; ripple less than 1 mV, peak-to-peak.	Same as Step 5.

4-8. ADJUSTMENT AND ALIGNMENT PROCEDURES

This subsection lists all required adjustments and alignment procedures. Note, however, that adjustment is not a substitute for troubleshooting; be certain that all other possible causes of equipment malfunction have been eliminated before making adjustments.

Connect the equipment, and depress the switches, as shown in Figure 4-3.

a. I.F. Adjustment.

- (1) Remove the r.f.-assembly cover (¶4-4b).
- (2) Set the output frequency of the signal generator to 100 MHz, c.w., and the output level to 0 dBm.
- (3) Adjust potentiometer A2R65 for a reading of 400 kHz, \pm 5 kHz, on the frequency counter.

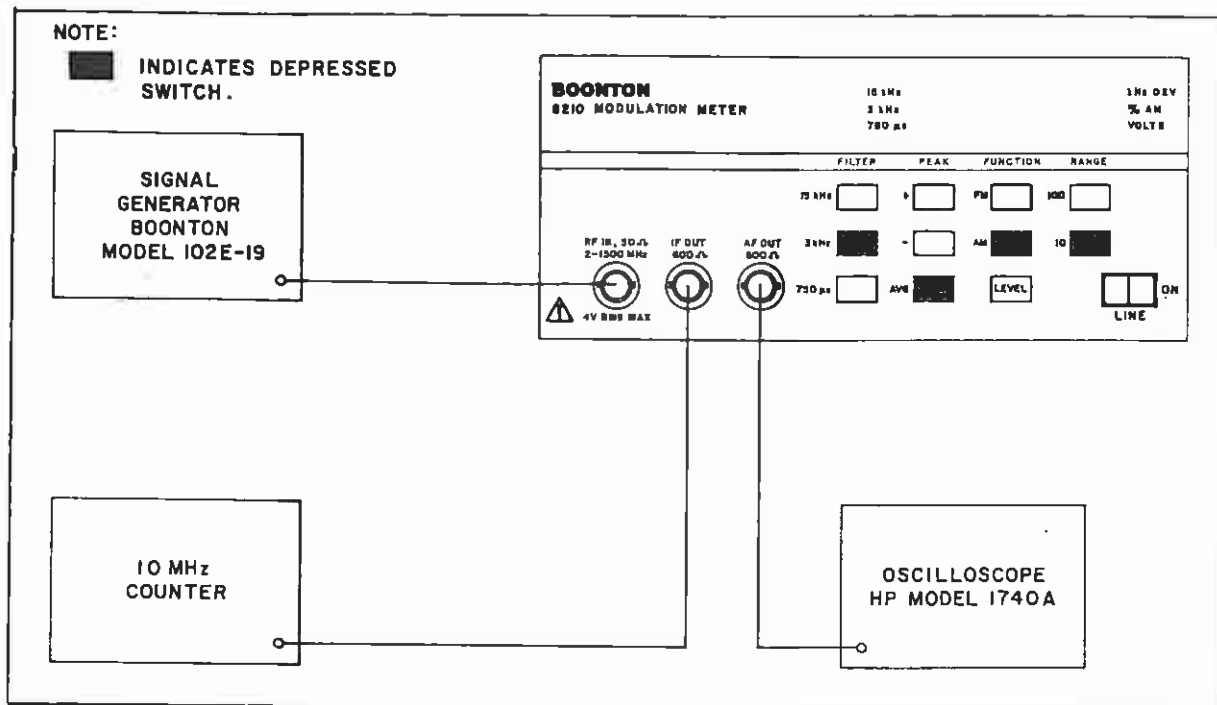

Figure 4-3. Test Setup: Adjustment and Alignment

b. R.F. Efficiency and F.M. Rejection.

- (1) Replace the r.f.-assembly cover.
- (2) Set the oscilloscope to 0.05 V/division and 1 ms/division.
- (3) Set the signal generator to 2 MHz, 0 dBm. Apply 100 kHz deviation at a 1 kHz rate. Let the i.f. to settle to within ± 5 kHz of 400 kHz (or, disconnect the 8210's r.f. input, then reconnect it).
- (4) Adjust potentiometer A2R10 for a minimum indication on the 'scope.
- (5) Set 102E-19's r.f. to 3.5 MHz. Wait 'til i.f. is 400 kHz ± 5 kHz.
- (6) Adjust potentiometer A3R6 for a minimum indication on the 'scope.
- (7) Repeat Steps 4-8b(3) through 4-8b(6) until the adjustment of either potentiometer increases the indication on the oscilloscope.

c. R.F. Sensitivity Adjustment (excepting early models; see Note, below).

- (1) Set the 102E-19 to 2 MHz, approx. -29.5 dBm. Remove all modulation.
- (2) If the 8210 displays IFLO, slowly adjust potentiometer A3R79* until a numeric display (i.e., a display of residual modulation) appears.
 * NOTE: Early model 8210's do not have potentiometer A3R79.

d. R.F. Balance Adjustment.

- (1) Disconnect the r.f. input to the 8210.
- (2) Disconnect the 'scope from AF OUT and connect it to RF IN.
- (3) Set the 'scope to 0.005 V/div., 50 Ω input, and 0.5 μ s/div.
- (4) Adjust potentiometer A2R14 for a minimum indication on the 'scope.

Table 4-12. Systematic Troubleshooting: Waveforms

FIG. #	REFERENCE TABLE	STEP	WAVEFORM	'SCOPE SETTINGS & SIGNAL CONDITIONS
--------	-----------------	------	----------	-------------------------------------

1 4-6 8

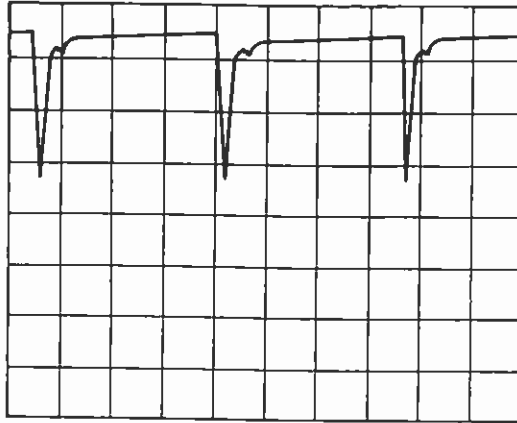

Vertical:
1 V/division, d.c.

Horizontal:
0.1 μ s/division.

2 4-6 9

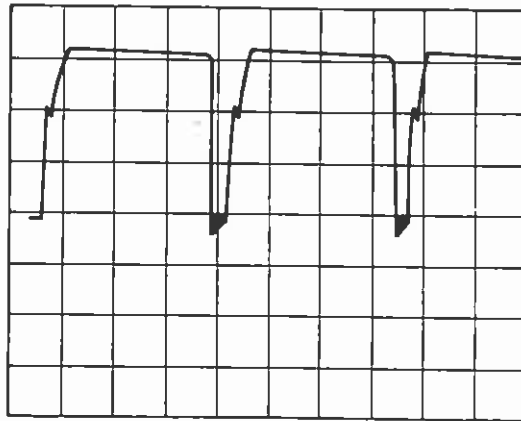

Vertical:
5 V/division, d.c.

Horizontal:
0.1 μ s/division.

3 4-6 10

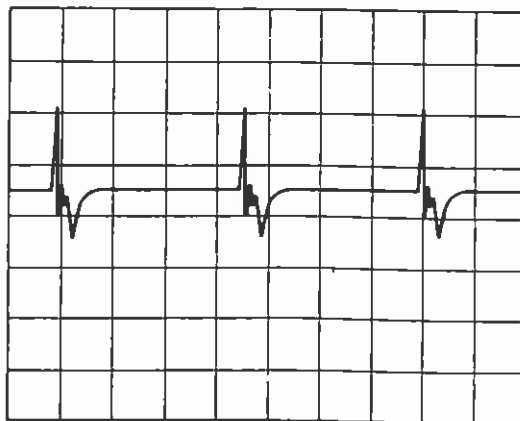

Vertical:
0.5 V/division, a.c.

Horizontal:
0.1 μ s/division.

Table 4-12. Systematic Troubleshooting: Waveforms (Continued)

FIG. #	REFERENCE: TABLE	STEP	WAVEFORM	'SCOPE SETTINGS & SIGNAL CONDITIONS
4	4-6	13		Vertical: 0.5 V/division. Horizontal: 1 μ s/division.
5	4-7	6		Vertical: 0.2 V/division. Horizontal: 1 μ s/division.
6	4-7	11		Vertical: 1 V/division, d.c. Horizontal: 1 μ s/division.

Table 4-12. Systematic Troubleshooting: Waveforms (Continued)

FIG. #	REFERENCE TABLE	STEP	WAVEFORM	'SCOPE SETTINGS & SIGNAL CONDITIONS
7	4-7	13		<p>Vertical: 0.2 V/division.</p> <p>Horizontal: 0.2 ms/division.</p>
8	4-7	17		<p>Vertical: 1 V/division, d.c.</p> <p>Horizontal: 1 μs/division.</p>
9	4-8	22		<p>Vertical (Channel A): 5 V/division, d.c. Channel-A probe to pin 10 of A4U22. Trigger on A. Negative trigger.</p> <p>Vertical (Channel B): 0.5 V/division, d.c. Display Channel B.</p> <p>Horizontal: Uncalibrated, 10 ms per division.</p>

Table 4-12. Systematic Troubleshooting: Waveforms (Continued)

FIG. #	REFERENCE: TABLE	STEP	WAVEFORM	'SCOPE SETTINGS & SIGNAL CONDITIONS
10	4-8	23		<p>Vertical (Channel A): 5 V/division, d.c. Channel-A probe to pin 10 of A4U22. Trigger on Channel A. Negative trigger.</p> <p>Vertical (Channel B): 0.5 V/division, d.c. Display Channel B.</p> <p>Horizontal: Uncalibrated, 10 ms per division.</p>
11	4-8	24		<p>Vertical (Channel A): 5 V/division, d.c. Channel-A probe to pin 10 of A4U22. Trigger on Channel A. Negative trigger.</p> <p>Vertical (Channel B): 0.5 V/division, d.c. Display Channel B.</p> <p>Horizontal: Uncalibrated, 20 ms per division.</p>
12	4-9	24		<p>Vertical: 1 V/division, d.c.</p> <p>Horizontal: 1 ms/division.</p>

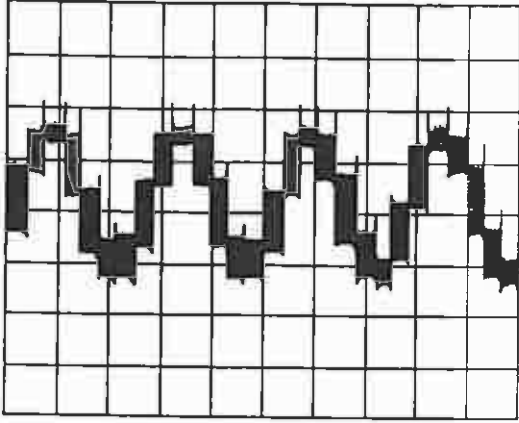
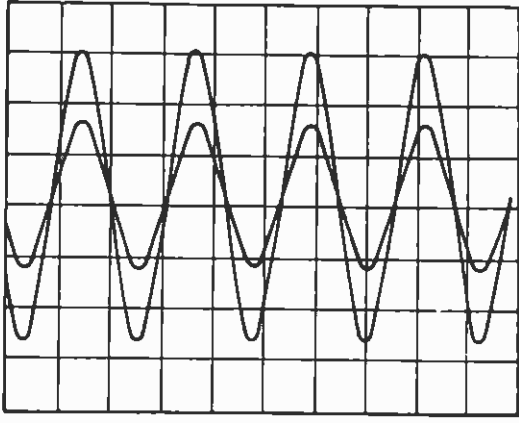
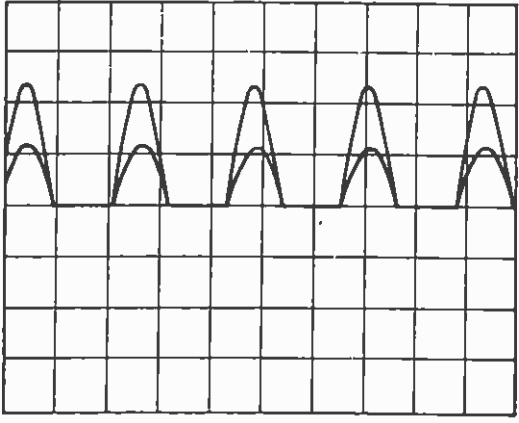
Table 4-12. Systematic Troubleshooting: Waveforms (Continued)

FIG. #	REFERENCE: TABLE	STEP	WAVEFORM	'SCOPE SETTINGS & SIGNAL CONDITIONS
13	4-9	39		Vertical: 1 V/division, d.c. Horizontal: 0.5 ms/division.
14	4-9	40		Vertical: 1 V/division, d.c. Horizontal: 0.5 ms/division.
15	4-10	11		Vertical: 0.5 V/division. Horizontal: 0.2 ms/division.

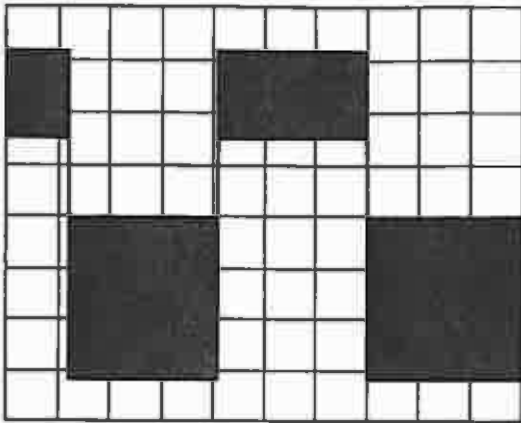
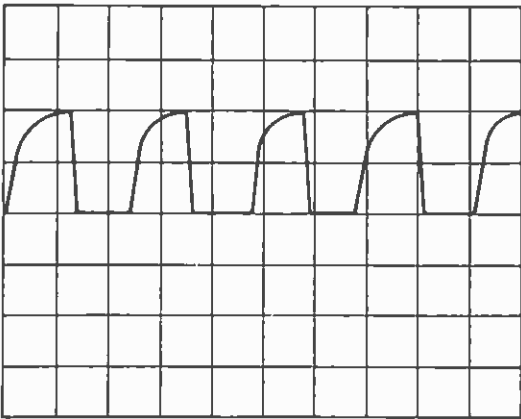
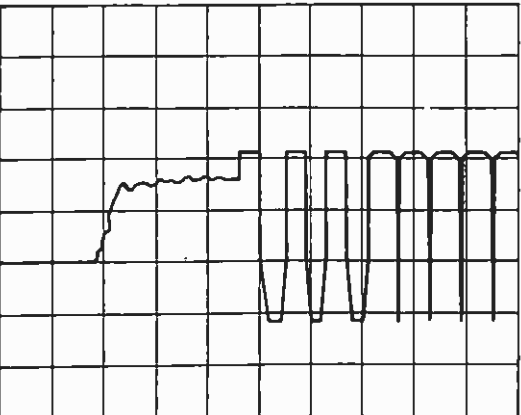
Table 4-12. Systematic Troubleshooting: Waveforms (Continued)

FIG. #	REFERENCE: TABLE	STEP	WAVEFORM	'SCOPE SETTINGS & SIGNAL CONDITIONS
--------	------------------	------	----------	-------------------------------------

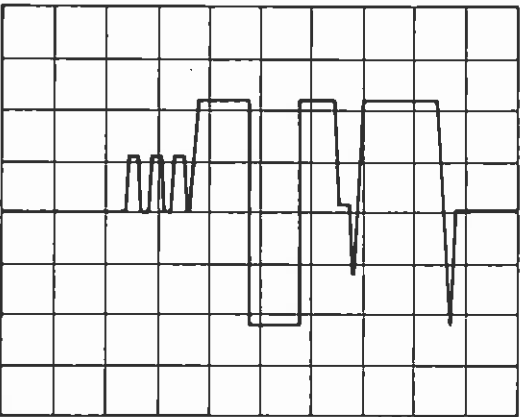
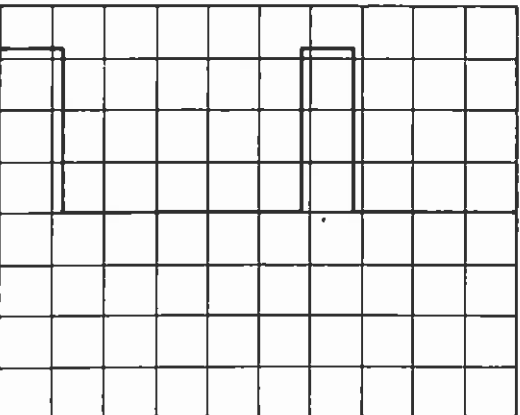
16 4-10 12

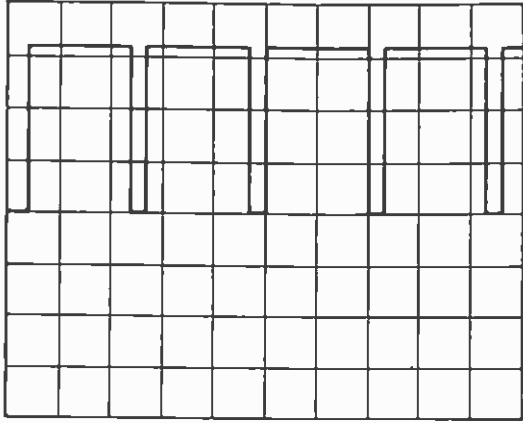
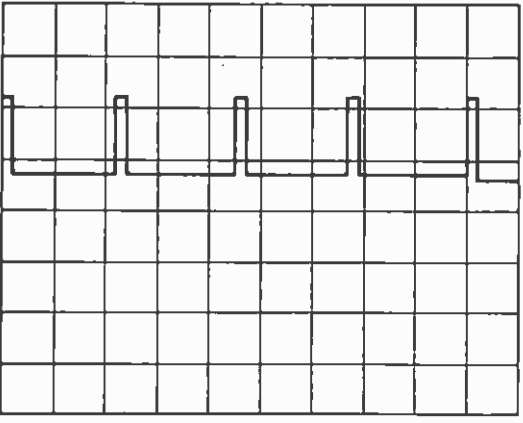
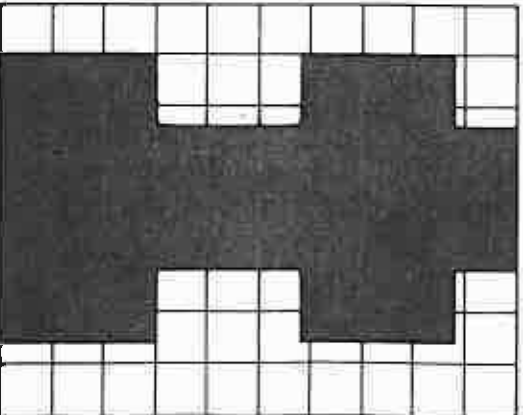
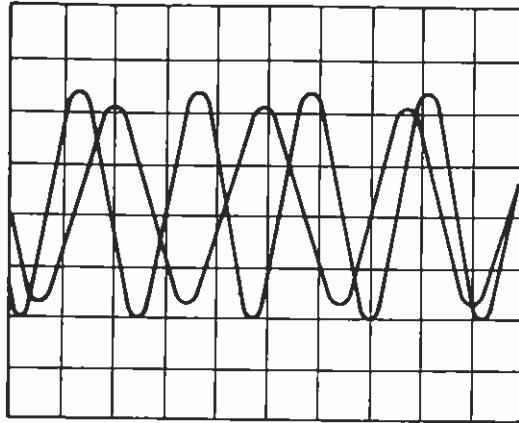

Vertical:
0.5 V/division.

Horizontal:
1 ms/division.

17 4-10 13

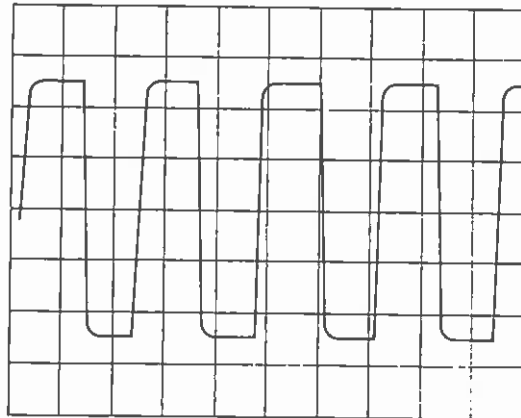

Vertical:
0.5 V/division.

Horizontal:
0.5 ms/division.

SECTION V

PARTS LIST

5-1. INTRODUCTION

The Table of Replaceable Parts begins with the Frame Assembly: the full set of PC-board assemblies, plus all components not mounted on PC boards. Then all the components of the individual PC-board assemblies are listed. To simplify ordering, please note the following:

a. When ordering a component or an assembly, the BEC Part Number is all that we need. However, part numbers can suffer changes during transmission and it is safer to include also a brief description. For example:
 BEC Part #200050: Mica Capacitor, 470 pF, 1%, 500V.

b. The number printed on a PC board is NOT an assembly number; it is the number for the bare board, alone. To order a complete assembly--the board with all its components installed--order it by the BEC Part Number given in the Frame Assembly section of this table.

c. Unless otherwise identified, the number on a schematic diagram or on a parts-location diagram is NOT an assembly number; it is the number for just the diagram itself.

Table 5-1. Manufacturers' Code Numbers

NUMBER	NAME	ADDRESS		
00853	Sangamo Electric Company	Pickens	SC	29671
01121	Allen Bradley Company	Milwaukee	WI	53204
01295	Texas Instruments Semiconductor Compon. Div.	Dallas	TX	75222
02114	Ferroxcube Corp.	Saugerties	NY	12477
02735	RCA Solid State Division	Somerville	NJ	08876
04222	AVX Ceramics Company	Myrtle Beach	SC	29577
04713	Motorola Semiconductor Products	Phoenix	AZ	85062
06383	Panduit Corp.	Tinley Park	IL	60477
06665	Precision Monolithics, Inc.	Santa Clara	CA	95050
06776	Robinson Nugent, Inc.	New Albany	IN	47150
07263	Fairchild Semiconductor Division	Mountain View	CA	94042
10236	Tally Industries, Electrodynamics Division	Rolling Meadows	IL	60008
13812	Amperex Electronics Corp., Dialight Division	Brooklyn	NY	11237
14752	Electro Cube, Inc.	San Gabriel	CA	91776
18324	Signetics Corp.	Sunnyvale	CA	94086
19505	Applied Engineering Products	New Haven	CT	06525
19701	Mepco Electra	Mineral Wells	TX	76067
24226	Gowanda Electronics Corp.	Gowanda	NY	14070
27014	National Semiconductor Corp.	Santa Clara	CA	95051
27264	Molex, Inc.	Lisle	IL	60532
27735	F-Dyne Electronics	Bridgeport	CT	06605
27777	Varo Semiconductors, Inc.	Garland	TX	75040
28480	Hewlett-Packard Corp.	Palo Alto	CA	94304
31433	Union Carbide, Kemet Electronics Division	Greenville	SC	29606
31918	ITT Schadow, Inc.	Eden Prairie	MN	55343
32997	Bourns Inc., Trimpot Products Division	Riverside	CA	92507
34335	Advanced Micro Devices, Inc.	Sunnyvale	CA	94086
34649	Intel Corp.	Aloha	OR	97005
50316	Mini-Systems, Inc.	North Attleboro	MA	02761
51406	Murata Corp. of America	Marietta	GA	30067
51640	Analog Devices, Inc.	Norwood	MA	02062
56289	Sprague Electric Company	North Adams	MA	01247
56708	Zilog, Inc.	Cupertino	CA	95014
57582	Kahgan Electronics Corp.	Hempstead	NY	11550
59474	Jeffers Electronics, Inc.	Nogales	AZ	85621
71450	CTS Corporation	Elkhart	IN	46514
73138	Beckman Instruments, Inc., Helipot Division	Fullerton	CA	92634
82389	Switchcraft, Inc.	Chicago	IL	60630
91418	P. R. Mallory & Co., Radio Materials Co. Div.	Chicago	IL	60646
95712	Bendix Corp., Dage Electric Division	Franklin	IN	46131
98291	Seallectro Corp.	Mamaronek	NY	10544
54217	United Chemicon, Inc.	Rosemont	IL	60018
5F520	Panel Components Corp.	Santa Rosa	CA	95401

Table 5-2. Replaceable Parts

Item	Description	Mfr.	Mfr's Part #	BEC Part #
FRAME ASSEMBLY (A1)				
A2	R.F. Board Assembly	BEC		082108
A3	I.F.-A.F. Board Assembly	BEC		082109
A4	Digital & Power-Supply Board Assembly	BEC		082107
A5	Display Board Assembly	BEC		082110
C1	Capacitor, Cer.	1000 pF, 20%, 1 kV	91418 Type B	224229
C2	Capacitor, Cer.	1000 pF, 20%, 1 kV	91418 Type B	224229
F1	Fuse, Slow-Blow	0.25A (110V Operation)	MDL-1/4-250	545511
F1	Fuse, Slow-Blow	0.125A (220V Operation)	MDL-1/8-250	545516
J1	Connector, BNC	95712	081-1	479123
J2	Connector, 50 Ω	19505		477305
J3	Connector, BNC	95712	081-1	479123
J4	Connector, BNC	95712	081-1	479123
J5	Connector, 4-pin	27264	03-06-1043	479340
P1	Connector, Power	5F520	8843.FS.32.60	477368
P14	Connector, 5-pin	06383	CE156F24-5-C	479394
P15	Connector, 4-pin	27264	03-06-2043	477306
S1	Switch, Slide	82389	47206LFR	465279
S2	Switch, Rocker	13812	572-2121-0103-010	465286
T1	Transformer, Power	BEC		446093
W1	Cable Assembly	I.F. Out	BEC	571162
W2	Cable Assembly	A.F. Out	BEC	571160
W3	Wire	R.F. to I.F.-A.F.	BEC	--
W4	Cable Unit, Flat	R.F. to Digital	BEC	920065
W5	Cable Unit, Flat	I.F.-A.F. to Digital	BEC	920065
W6	Cable Unit, Flat	I.F.-A.F. to Digital	BEC	920065
W7	Cable Assembly	I.F.-A.F. to Digital	BEC	571161
W8	Cable Unit, Flat	Digital to Display	BEC	920065
W9	Wire	Digital to Display	BEC	--
R.F. BOARD ASSEMBLY (A2); PART NUMBER 082108				
C1	Capacitor, Cer.	0.1 μF, 20%, 50V	04222 SR215E104MAA	224268
C2	Capacitor, El.	10 μF, 20%, 25V	S4217 SM25-VB-10M	283336
C3	Capacitor, Cer. Chip	0.01 μF, 20%, 100V	31433 C1210C103M5XAH	224210
C4	Capacitor, El.	10 μF, 20%, 25V	S4217 SM25-VB-10M	283336
C5	Capacitor, Cer. Chip	680 pF, 10%, 50V	31433 C1210C681K5XAH	224377
C6	Capacitor, Cer.	0.01 μF, 20%, 50V	51406 DD350A10Y5P103M50V	224363
C7	Capacitor, Mica	100 pF, 1%, 500V	DM15-101F	200045
C8	Capacitor, Cer.	0.01 μF, 20%, 50V	51406 DD350A10Y5P103M50V	224363
C9	Capacitor, Mica	100 pF, 5%, 300V	DM5-FC101J	205006
C10	Capacitor, Tant.	1.0 μF, 10%, 35V	56289 196D105X9035HA1	283216
C11	Capacitor, El.	10 μF, 20%, 25V	S4217 SM25-VB-10M	283336
C12	Capacitor, Mica	100 pF, 5%, 300V	DM5-FC101J	205006
C13	Capacitor, Tant.	1.0 μF, 10%, 35V	56289 196D105X9035HA1	283216
C14	Capacitor, Mica	100 pF, 1%, 500V	DM15-101F	200045
C15	Capacitor, Mica	33 pF, 5%, 300V	DM5-EC330J	205010
C16	Not Used			
C17	Capacitor, Mica	8 pF, 10%, 300V	DM5-CC080K	205001
C18	Capacitor, Cer.	0.1 μF, 20%, 50V	04222 SR215E104MAA	224268
C19	Capacitor, El.	10 μF, 20%, 25V	S4217 SM25-VB-10M	283336
C20	Capacitor, Cer.	0.1 μF, 20%, 50V	04222 SR215E104MAA	224268
C21	Capacitor, Mica	270 pF, 5%, 50V	DM5-FY271J	205045
C22	Capacitor, Cer.	0.1 μF, 20%, 50V	04222 SR215E104MAA	224268
C23	Capacitor, Cer.	0.1 μF, 20%, 50V	04222 SR215E104MAA	224268
C24	Capacitor, Cer.	0.1 μF, 20%, 50V	04222 SR215E104MAA	224268
C25	Capacitor, Cer.	0.1 μF, 20%, 50V	04222 SR215E104MAA	224268
C26	Capacitor, Cer.	0.1 μF, 20%, 50V	04222 SR215E104MAA	224268
C27	Capacitor, Mica	15 pF, 5%, 300V	DM5-CC150J	205035
C28	Capacitor, Mica	47 pF, 5%, 300V	DM5-EC470J	205018
C29	Capacitor, Cer.	1000 pF, 10%, 100V	04222 SR151C102KAA	224270
C30	Capacitor, El.	10 μF, 20%, 25V	S4217 SM25-VB-10M	283336

Table 5-2. Replaceable Parts (Continued)

Item	Description	Mfr.	Mfr's Part #	BEC Part #	
R.F. BOARD ASSEMBLY (A2); PART NUMBER 082108					
C31	Capacitor, Cer.	0.01 μ F, 10%, 100V	04222	SR201C103KAA	224269
C32	Capacitor, El.	100 μ F, 20%, 25V	S4217	SM25-VB-100M	283334
C33	Capacitor, Mica	10 pF, 5%, 300V		DM5-CC100J	205002
C34	Capacitor, Mica	22 pF, 5%, 300V		DM5-CC220J	205036
C35	Capacitor, El.	10 μ F, 20%, 25V	S4217	SM25-VB-10M	283336
C36	Capacitor, Mica	270 pF, 5%, 50V		DM5-FY271J	205045
C37	Capacitor, Mica	270 pF, 5%, 50V		DM5-FY271J	205045
C38	Capacitor, Tant.	10 μ F, 20%, 25V	56289	196D106X0025KA1	283293
C39	Capacitor, Cer.	0.01 μ F, 10%, 100V	04222	SR201C103KAA	224269
C40	Capacitor, El.	10 μ F, 20%, 25V	S4217	SM25-VB-10M	283336
C41	Capacitor, Cer.	0.01 μ F, 10%, 100V	04222	SR201C103KAA	224269
C42	Capacitor, Mica	390 pF, 5%, 500V		DM15-391J	200108
C43	Capacitor, Mica	390 pF, 5%, 500V		DM15-391J	200108
C44	Capacitor, El.	100 μ F, 20%, 25V	S4217	SM25-VB-100M	283334
C45	Capacitor, Mica	270 pF, 5%, 50V		DM5-FY271J	205045
C46	Capacitor, Mica	270 pF, 5%, 50V		DM5-FY271J	205045
C47	Capacitor, MPC	1.0 μ F, 10%, 50V	14752	652A-1-A-105K	234152
C48	Capacitor, Tant.	10 μ F, 20%, 25V	56289	196D106X0025KA1	283293
C49	Not Used				
C50	Capacitor, Tant.	10 μ F, 20%, 25V	56289	196D106X0025KA1	283293
C51	Capacitor, Cer.	0.1 μ F, 20%, 50V	04222	SR215E104MAA	224268
C52	Capacitor, Cer.	0.1 μ F, 20%, 50V	04222	SR215E104MAA	224268
C53	Capacitor, Cer.	0.1 μ F, 20%, 50V	04222	SR215E104MAA	224268
C54	Not Used				
C55	Capacitor, Cer.	0.1 μ F, 20%, 50V	04222	SR215E104MAA	224268
C56	Capacitor, Mica	47 pF, 5%, 300V		DM5-EC470J	205018
C57	Capacitor, Tant.	1.0 μ F, 10%, 35V	56289	196D105X9035HA1	283216
C58	Capacitor, Mica	100 pF, 5%, 300V		DM5-FC101J	205006
C59	Capacitor, Cer.	0.1 μ F, 20%, 50V	04222	SR215E104MAA	224268
C60	Capacitor, El.	10 μ F, 20%, 25V	S4217	SM25-VB-10M	283336
CR1	Diode, Signal	1N6263	28480		530174
CR2	Diode, Quad	5082-2815	28480		530903
CR3	Diode, PIN	5082-0180	28480		530168
CR4	Diode, Signal	1N6263	28480		530174
CR5	Diode, Signal	1N914	01295		530058
CR6	Diode, Signal	1N914	01295		530058
CR7	Diode, Signal	1N6263	28480		530174
CR8	Diode, Signal	1N6263	28480		530174
CR9	Diode, Varactor	MV2115	04713		530760
CR10	Diode, Varactor	MV2115	04713		530760
CR11	Diode, Signal	1N914	01295		530058
CR12	Diode, Signal	1N914	01295		530058
CR13	Diode, Signal	1N6263	28480		530174
L1	Choke, R.F.	33 μ H, 5%	59474	4465-2J	400310
L2	Coil, Osc.	0.72 μ H		BEC	400417
L3	Choke, R.F.	4.7 μ H, 10%	59474	4425-14X	400292
L4	Choke, R.F.	4.7 μ H, 10%	24226	10/471	400384
L5	Choke, R.F.	5.6 μ H, 10%	59474	4435-1K	400308
L6	Choke, R.F.	68 μ H, 10%	24226	10/682	400411
L7	Choke, R.F.	39 μ H, 10%	24226	10/392	400387
L8	Choke, R.F.	5.6 μ H, 10%	59474	4435-1K	400308
L9	Choke, R.F.	68 μ H, 10%	24226	10/682	400411
L10	Choke, R.F.	39 μ H, 10%	24226	10/392	400387
L11	Choke, R.F.	5.6 μ H, 10%	59474	4435-1K	400308
P1	Connector, R.F.		98291	52-054-0000	479336
Q1	Transistor, NPN	2N3866	04713		528116
Q2	Transistor, FET	2N4416	04713		528072
Q3	Transistor, PNP	2N3906	04713		528076
Q4	Transistor, NPN	2N3904	04713		528071
Q5	Transistor, NPN	2N3904	04713		528071
Q6	Transistor, PNP	2N3906	04713		528076
Q7	Transistor, NPN	MPS-6507	04713		528070
Q8	Transistor, FET	2N4416	04713		528072

Table 5-2. Replaceable Parts (Continued)

Item	Description	Mfr.	Mfr's Part #	BEC Part #
R.F. BOARD ASSEMBLY (A2), CONTINUED; PART NUMBER 082108				
R1	Resistor, Comp.	33 Ω , 5%	01121 CB	343150
R2	Resistor, Comp.	300 Ω , 5%	01121 CB	343246
R3	Resistor, Chip	18 Ω , 5%	50316 WA-7	339996
R4	Resistor, Comp.	300 Ω , 5%	01121 CB	343246
R5	Resistor, Comp.	330 Ω , 5%	01121 CB	343250
R6	Resistor, Comp.	100 Ω , 5%	01121 CB	343200
R7	Resistor, Comp.	6.8 k Ω , 5%	01121 CB	343380
R8	Resistor, Comp.	100 Ω , 5%, 1/8W	01121 BB	331058
R9	Resistor, Comp.	100 Ω , 5%, 1/8W	01121 BB	331058
R10	Resistor, Var.	50 k Ω , 10%, 0.5W	73138 72PR50K	311393
R11	Resistor, Comp.	7.5 k Ω , 5%	01121 CB	343384
R12	Resistor, Comp.	100 Ω , 5%, 1/8W	01121 BB	331058
R13	Resistor, Comp.	33 Ω , 5%	01121 CB	343150
R14	Resistor, Var.	10 k Ω , 10%, 0.5W	73138 72PR10K	311328
R15	Resistor, Comp.	5.1 k Ω , 5%	01121 CB	343368
R16	Resistor, Comp.	7.5 k Ω , 5%	01121 CB	343384
R17	Resistor, Comp.	100 Ω , 5%, 1/8W	01121 BB	331058
R18	Resistor, Comp.	6.8 k Ω , 5%	01121 CB	343380
R19	Resistor, Comp.	100 Ω , 5%, 1/8W	01121 BB	331058
R20	Resistor, Comp.	100 Ω , 5%, 1/8W	01121 BB	331058
R21	Resistor, Comp.	100 Ω , 5%	01121 CB	343200
R22	Resistor, Comp.	1 k Ω , 5%	01121 CB	343300
R23	Resistor, Comp.	3.9 k Ω , 5%	01121 CB	343357
R24	Resistor, Comp.	20 k Ω , 5%	01121 CB	343429
R25	Resistor, Comp.	7.5 k Ω , 5%	01121 CB	343384
R26	Resistor, Comp.	510 Ω , 5%	01121 CB	343268
R27	Resistor, Comp.	22 Ω , 5%	01121 CB	343123
R28	Resistor, Comp.	510 Ω , 5%	01121 CB	343268
R29	Resistor, Comp.	47 Ω , 5%, 1/8W	01121 BB	331050
R30	Resistor, Comp.	47 Ω , 5%	01121 CB	343165
R31	Resistor, Comp.	47 Ω , 5%, 1/8W	01121 BB	331050
R32	Resistor, Comp.	22 Ω , 5%	01121 CB	343133
R33	Resistor, Comp.	100 Ω , 5%	01121 CB	343200
R34	Resistor, Comp.	4.7 k Ω , 5%	01121 CB	343365
R35	Resistor, Comp.	510 Ω , 5%	01121 CB	343268
R36	Resistor, Comp.	510 Ω , 5%	01121 CB	343268
R37	Resistor, Comp.	15 k Ω , 5%	01121 CB	343417
R38	Resistor, Comp.	1 k Ω , 5%	01121 CB	343300
R39	Resistor, MF	511 Ω , 1%	RN55	341268
R40	Resistor, Comp.	3 k Ω , 5%	01121 CB	343346
R41	Resistor, Comp.	360 Ω , 5%	01121 CB	343253
R42	Resistor, MF	51.5 k Ω , 1%	RN55	341468
R43	Resistor, MF	243 Ω , 1%	RN55	341237
R44	Resistor, MF	47.5 k Ω , 1%	RN55	341465
R45	Resistor, MF	20.0 k Ω , 1%	RN55	341429
R46	Resistor, MF	47.5 k Ω , 1%	RN55	341465
R47	Resistor, MF	90.9 k Ω , 1%	RN55	341492
R48	Resistor, Comp.	47 Ω , 5%, 1/8W	01121 BB	331050
R49	Resistor, MF	10.0 k Ω , 1%	RN55	341400
R50	Resistor, Comp.	1 k Ω , 5%	01121 CB	343300
R51	Resistor, Comp.	5.1 k Ω , 5%	01121 CB	343368
R52	Resistor, Comp.	1 k Ω , 5%	01121 CB	343300
R53	Resistor, Comp.	510 Ω , 5%	01121 CB	343268
R54	Resistor, Comp.	47 Ω , 5%	01121 CB	343165
R55	Resistor, Comp.	510 Ω , 5%	01121 CB	343268
R56	Resistor, Comp.	10 k Ω , 5%	01121 CB	343400
R57	Resistor, Comp.	200 k Ω , 5%	01121 CB	343529
R58	Resistor, Comp.	10 k Ω , 5%	01121 CB	343400
R59	Resistor, Comp.	2 k Ω , 5%	01121 CB	343329
R60	Resistor, Comp.	200 k Ω , 5%	01121 CB	343529
R61	Resistor, Comp.	10 k Ω , 5%	01121 CB	343400
R62	Resistor, Comp.	2 k Ω , 5%	01121 CB	343329
R63	Resistor, Comp.	820 Ω , 5%	01121 CB	343288
R64	Resistor, Comp.	10 k Ω , 5%	01121 CB	343400
R65	Resistor, Var.	2 k Ω , 10%, 0.5W	73138 72PR2K	311343
R66	Resistor, Comp.	1 k Ω , 5%	01121 CB	343300
R67	Resistor, Comp.	10 k Ω , 5%	01121 CB	343400
R68	Resistor, Comp.	1 k Ω , 5%	01121 CB	343300
R69	Resistor, Comp.	4.7 k Ω , 5%	01121 CB	343365
R70	Resistor, MF	24.3 k Ω , 1%	RN55	341437

Table 5-2. Replaceable Parts (Continued)

Item	Description	Mfr.	Mfr's Part #	BEC Part #
R.F. BOARD ASSEMBLY (A2), CONTINUED; PART NUMBER 082108				
R71	Resistor, Comp.	39 k Ω , 5%	01121 CB	343457
T1	Transformer, Pulse Gen.		BEC	410090
T2	Transformer, Balun		BEC	410089
U1	Integrated Circuit	SN74ALS74N	01295	534281
U2	Integrated Circuit	SN74LS163N	01295	534279
U3	Integrated Circuit	SN74LS00N	01295	534167
U4	Analog Switch	LF13333N	27014	535095
U5	Oper. Amplifier	LF357N	27014	535096
U6	Oper. Amplifier	TL072CP	01295	535092
U7	Integrated Circuit	CD4051BE	02735	535209
U8	Oper. Amplifier	MC1355P	04713	535038
U9	Integrated Circuit	SN74LS122N	01295	534280
I.F.-A.F. BOARD ASSEMBLY (A3); PART NUMBER 082109				
C1	Capacitor, Mica	470 pF, 1%, 500V		200050
C2	Capacitor, Mica	240 pF, 1%, 500V	00853	200124
C3	Capacitor, Mica	15 pF, 5%, 300V		205035
C4	Capacitor, Cer.	0.01 μ F, 10%, 100V	04222	224269
C5	Capacitor, Tant.	1.0 μ F, 10%, 35V	56289	283216
C6	Capacitor, El.	100 μ F, 20%, 25V	S4217	283334
C7	Capacitor, Cer.	0.1 μ F, 20%, 25V	51406	224364
C8	Capacitor, Tant.	1.0 μ F, 10%, 35V	56289	283216
C9	Capacitor, Mica	150 pF, 5%, 100V		205009
C10	Capacitor, Mica	100 pF, 5%, 300V		205006
C11	Capacitor, El.	10 μ F, 20%, 25V	S4217	283336
C12	Capacitor, Mica	33 pF, 5%, 300V		205010
C13	Capacitor, Cer.	0.1 μ F, 20%, 50V	04222	224268
C14	Capacitor, El.	10 μ F, 20%, 25V	S4217	283336
C15	Capacitor, Cer.	0.1 μ F, 20%, 25V	51406	224364
C16	Not Used			
C17	Capacitor, El.	10 μ F, 20%, 25V	S4217	283336
C18	Capacitor, Cer.	0.1 μ F, 20%, 25V	51406	224364
C19	Capacitor, El.	10 μ F, 20%, 25V	S4217	283336
C20	Capacitor, Mica	39 pF, 5%, 300V		205044
C21	Capacitor, Tant.	10 μ F, 20%, 25V	56289	283293
C22	Capacitor, Cer.	0.1 μ F, 20%, 50V	04222	224268
C23	Capacitor, Cer.	1.0 μ F, 20%, 50V	04222	224264
C24	Capacitor, El.	10 μ F, 20%, 25V	S4217	283336
C25	Capacitor, El.	100 μ F, 20%, 25V	S4217	283334
C26	Capacitor, El.	100 μ F, 20%, 25V	S4217	283334
C27	Capacitor, Mica	47 pF, 5%, 300V		205018
C28	Capacitor, Mica	47 pF, 5%, 300V		205018
C29	Capacitor, Cer.	0.1 μ F, 20%, 50V	04222	224268
C30	Capacitor, Cer.	0.1 μ F, 20%, 25V	51406	224364
C31	Capacitor, El.	10 μ F, 20%, 25V	S4217	283336
C32	Capacitor, El.	10 μ F, 20%, 25V	S4217	283336
C33	Capacitor, El.	100 μ F, 20%, 25V	S4217	283334
C34	Capacitor, El.	100 μ F, 20%, 25V	S4217	283334
C35	Capacitor, Mica	500 pF, 1%, 500V	00853	200123
C36	Capacitor, Mica	120 pF, 5%, 100V		205022
C37	Capacitor, Tant.	10 μ F, 20%, 25V	56289	283293
C38	Capacitor, Mica	1000 pF, 1%, 100V		200113
C39	Capacitor, Mica	1000 pF, 1%, 100V		200113
C40	Capacitor, Mica	240 pF, 1%, 500V	00853	200124
C41	Capacitor, Mica	200 pF, 2%, 500V		200053
C42	Capacitor, Cer.	0.1 μ F, 20%, 50V	04222	224268
C43	Capacitor, Mica	100 pF, 5%, 300V		205006
C44	Capacitor, Mica	1000 pF, 1%, 100V		200113
C45	Capacitor, MPC	0.1 μ F, 2%, 50V	27735	234139
C46	Capacitor, Mica	100 pF, 5%, 300V		205006
C47	Capacitor, Mica	1000 pF, 1%, 100V		200113
C48	Capacitor, Mica	100 pF, 5%, 300V		205006
C49	Capacitor, Cer.	0.1 μ F, 20%, 25V	51406	224364
C50	Capacitor, Cer.	0.1 μ F, 20%, 25V	51406	224364
C51	Capacitor, Tant.	10 μ F, 20%, 25V	56289	283293
C52	Capacitor, Cer.	0.1 μ F, 20%, 25V	51406	224364

Table 5-2. Replaceable Parts (Continued)

Item	Description	Mfr.	Mfr's Part #	BEC Part #
I.F.-A.F. BOARD ASSEMBLY (A3), CONTINUED; PART NUMBER 082109				
CR1	Diode, Signal	1N914	01295	530058
CR2	Diode, Signal	1N914	01295	530058
CR3	Diode, Signal	1N6263	28480	530174
CR4	Diode, Signal	1N6263	28480	530174
CR5	Diode, Signal	1N6263	28480	530174
CR6	Diode, Signal	1N6263	28480	530174
CR7	Diode, Signal	1N6263	28480	530174
CR8	Diode, Signal	1N914	01295	530058
CR9	Diode, Signal	1N914	01295	530058
CR10	Diode, Signal	1N914	01295	530058
CR11	Diode, Signal	1N914	01295	530058
CR12	Diode, Signal	1N914	01295	530058
CR13	Diode, Signal	1N914	01295	530058
J1	Connector, 16-pin		06776	473042
J2	Connector, 16-pin		06776	473042
J3	Connector, 2-pin		06383	HFAS100-2-C 477367
J4	Connector, 2-pin		06383	HFAS100-2-C 477367
J5	Connector, 2-pin		06383	HFAS100-2-C 477367
L1	Choke, R.F.	100 μ H, 5%	59474	1315-12J 400295
L2	Choke, R.F.	91 μ H, 5%	59474	1311-11J 400416
L3	Choke, R.F.	20 μ H, 5%	59474	4445-6J 400258
L4	Choke, R.F.	150 μ H, 5%	59474	1315-16J 400415
L5	Choke, Wide-band		02114	VK200-20/4B 400409
L6	Choke, R.F.	5.6 μ H, 10%	59474	4435-1K 400308
L7	Choke, R.F.	5.6 μ H, 10%	59474	4435-1K 400308
L8	Choke, R.F.	5.6 μ H, 10%	59474	4435-1K 400308
L9	Choke, R.F.	5.6 μ H, 10%	59474	4435-1K 400308
Q1	Transistor, NPN	2N3904	04713	528071
Q2	Transistor, PNP	2N3906	04713	528076
Q3	Transistor, NPN	2N3904	04713	528071
Q4	Transistor, PNP	2N3906	04713	528076
Q5	Transistor, PNP	2N3906	04713	528076
Q6	Transistor, NPN	2N3904	04713	528071
R1	Resistor, Comp.	330 Ω , 5%, 1/8W	01121	BB 331070
R2	Resistor, Comp.	10 k Ω , 5%	01121	CB 343400
R3	Resistor, Comp.	220 Ω , 5%	01121	CB 343233
R4	Resistor, Comp.	200 Ω , 5%	01121	CB 343229
R5	Resistor, Comp.	10 k Ω , 5%	01121	CB 343400
R6	Resistor, Var.	100 Ω , 10%, 0.5W	32997	3329H-1-101 311406
R7	Resistor Network	500 Ω , 0.5%, 0.5W	73138	694-3-R500D 345035
R8	Resistor, Comp.	2 k Ω , 5%	01121	CB 343329
R9	Resistor, Comp.	5.1 k Ω , 5%	01121	CB 343368
R10	Resistor, Comp.	1 k Ω , 5%	01121	CB 343300
R11	Resistor, Comp.	10 k Ω , 5%	01121	CB 343400
R12	Resistor, Comp.	10 k Ω , 5%	01121	CB 343400
R13	Resistor, Comp.	100 Ω , 5%	01121	CB 343200
R14	Resistor, Comp.	15 k Ω , 5%	01121	CB 343417
R15	Resistor, Comp.	1.8 k Ω , 5%	01121	CB 343325
R16	Resistor, Comp.	1.5 k Ω , 5%	01121	CB 343317
R17	Resistor, Comp.	470 Ω , 5%	01121	CB 343265
R18	Resistor, Comp.	10 k Ω , 5%	01121	CB 343400
R19	Resistor, Comp.	3.3 k Ω , 5%	01121	CB 343350
R20	Resistor, Comp.	6.2 k Ω , 5%	01121	CB 343376
R21	Resistor, Comp.	510 Ω , 5%	01121	CB 343268
R22	Resistor, Comp.	470 Ω , 5%	01121	CB 343265
R23	Resistor, Comp.	1.5 k Ω , 5%	01121	CB 343317
R24	Resistor, Comp.	47 Ω , 5%	01121	CB 343165
R25	Resistor, Comp.	2.2 k Ω , 5%	01121	CB 343333
R26	Resistor, Comp.	2 k Ω , 5%	01121	CB 343329
R27	Resistor, Comp.	1 k Ω , 5%	01121	CB 343300
R28	Resistor, Comp.	47 Ω , 5%	01121	CB 343165
R29	Resistor, Comp.	100 Ω , 5%	01121	CB 343200
R30	Resistor, Comp.	15 k Ω , 5%	01121	CB 343417
R31	Resistor, Comp.	6.2 k Ω , 5%	01121	CB 343376
R32	Resistor, Comp.	15 k Ω , 5%	01121	CB 343417

Table 5-2. Replaceable Parts (Continued)

Item	Description	Mfr.	Mfr's Part #	BEC Part #
R-F. BOARD ASSEMBLY (A2), CONTINUED; PART NUMBER 082108				
R71	Resistor, Comp. 39 kΩ, 5%	01121	CB	343457
T1	Transformer, Pulse Gen.	BEC		410090
T2	Transformer, Balun	BEC		410089
U1	Integrated Circuit			
U2	Integrated Circuit	SN74ALS74N	01295	534281
U3	Integrated Circuit	SN74LS163N	01295	534279
U4	Analog Switch	SN74LS00N	01295	534167
U5	Oper. Amplifier	LF13333N	27014	535095
		LF357N	27014	535096
U6	Oper. Amplifier	TLO72CP	01295	535092
U7	Integrated Circuit	CD4051BE	02735	535209
U8	Oper. Amplifier	MC1355P	04713	535038
U9	Integrated Circuit	SN74LS122N	01295	534280
I.F.-A.F. BOARD ASSEMBLY (A3); PART NUMBER 082109				
C1	Capacitor, Mica	470 pF, 1%, 500V		200050
C2	Capacitor, Mica	240 pF, 1%, 500V	00853	200124
C3	Capacitor, Mica	15 pF, 5%, 300V		205035
C4	Capacitor, Cer.	0.01 μF, 10%, 100V	04222	224269
C5	Capacitor, Tant.	1.0 μF, 10%, 35V	56289	283216
C6	Capacitor, El.	100 μF, 20%, 25V	54217	283334
C7	Capacitor, Cer.	0.1 μF, 20%, 25V	51406	224364
C8	Capacitor, Tant.	1.0 μF, 10%, 35V	56289	283216
C9	Capacitor, Mica	150 pF, 5%, 100V		205009
C10	Capacitor, Mica	100 pF, 5%, 300V		205006
C11	Capacitor, El.	10 μF, 20%, 25V	54217	283336
C12	Capacitor, Mica	33 pF, 5%, 300V		205010
C13	Capacitor, Cer.	0.1 μF, 20%, 50V	04222	224268
C14	Capacitor, El.	10 μF, 20%, 25V	54217	283336
C15	Capacitor, Cer.	0.1 μF, 20%, 25V	51406	224364
C16	Not Used			
C17	Capacitor, El.	10 μF, 20%, 25V	54217	283336
C18	Capacitor, Cer.	0.1 μF, 20%, 25V	51406	224364
C19	Capacitor, El.	10 μF, 20%, 25V	54217	283336
C20	Capacitor, Mica	39 pF, 5%, 300V		205044
C21	Capacitor, Tant.	10 μF, 20%, 25V	56289	283293
C22	Capacitor, Cer.	0.1 μF, 20%, 50V	04222	224268
C23	Capacitor, Cer.	1.0 μF, 20%, 50V	04222	224264
C24	Capacitor, El.	10 μF, 20%, 25V	54217	283336
C25	Capacitor, El.	100 μF, 20%, 25V	54217	283334
C26	Capacitor, El.	100 μF, 20%, 25V	54217	283334
C27	Capacitor, Mica	47 pF, 5%, 300V		205018
C28	Capacitor, Mica	47 pF, 5%, 300V		205018
C29	Capacitor, Cer.	0.1 μF, 20%, 50V	04222	224268
C30	Capacitor, Cer.	0.1 μF, 20%, 25V	51406	224364
C31	Capacitor, El.	10 μF, 20%, 25V	54217	283336
C32	Capacitor, El.	10 μF, 20%, 25V	54217	283336
C33	Capacitor, El.	100 μF, 20%, 25V	54217	283334
C34	Capacitor, El.	100 μF, 20%, 25V	54217	283334
C35	Capacitor, Mica	500 pF, 1%, 500V	00853	200123
C36	Capacitor, Mica	120 pF, 5%, 100V		205022
C37	Capacitor, Tant.	10 μF, 20%, 25V	56289	283293
C38	Capacitor, Mica	1000 pF, 1%, 100V		200113
C39	Capacitor, Mica	1000 pF, 1%, 100V		200113
C40	Capacitor, Mica	240 pF, 1%, 500V	00853	200124
C41	Capacitor, Mica	200 pF, 2%, 500V		200053
C42	Capacitor, Cer.	0.1 μF, 20%, 50V	04222	224268
C43	Capacitor, Mica	100 pF, 5%, 300V		205006
C44	Capacitor, Mica	1000 pF, 1%, 100V		200113
C45	Capacitor, MPC	0.1 μF, 20%, 50V	27735	234139
C46	Capacitor, Mica	100 pF, 5%, 300V		205006
C47	Capacitor, Mica	1000 pF, 1%, 100V		200113
C48	Capacitor, Mica	100 pF, 5%, 300V		205006
C49	Capacitor, Cer.	0.1 μF, 20%, 25V	51406	224364
C50	Capacitor, Cer.	0.1 μF, 20%, 25V	51406	224364
C51	Capacitor, Tant.	10 μF, 20%, 25V	56289	283293
C52	Capacitor, Cer.	0.1 μF, 20%, 25V	51406	224364

To Remove Opt 2, make C47 1000pf mica

Table 5-2. Replaceable Parts (Continued)

Item	Description	Mfr.	Mfr's Part #	BEC Part #
I.F.-A.F. BOARD ASSEMBLY (A3), CONTINUED; PART NUMBER 082109				
R33	Resistor, MF	39.2 k Ω , 1%	RN55	341457
R34	Resistor, Comp.	47 Ω , 5%	01121 CB	343165
R35	Resistor, Comp.	470 Ω , 5%	01121 CB	343265
R36	Resistor, Comp.	470 Ω , 5%	01121 CB	343265
R37	Resistor, Comp.	47 Ω , 5%	01121 CB	343165
R38	Resistor, Comp.	2 k Ω , 5%	01121 CB	343329
R39	Resistor, Comp.	6.2 k Ω , 5%	01121 CB	343376
R40	Resistor, Comp.	10 k Ω , 5%	01121 CB	343400
R41	Resistor, Comp.	2 k Ω , 5%	01121 CB	343329
R42	Resistor, Comp.	10 k Ω , 5%	01121 CB	343400
R43	Resistor, MF	243 Ω , 1%	RN55	341237
R44	Resistor, MF	2.0 k Ω , 1%	RN55	341329
R45	Resistor, MF	150 Ω , 1%	RN55	341217
R46	Resistor, MF	1.0 k Ω , 1%	RN55	341300
R47	Resistor, MF	52.3 k Ω , 1%	RN55	341469
R48	Resistor, MF	52.3 k Ω , 1%	RN55	341469
R49	Not Used			
R50	Resistor, MF	10.0 k Ω , 1%	RN55	341400
R51	Resistor, MF	10.0 k Ω , 1%	RN55	341400
R52	Resistor, MF	10.0 k Ω , 1%	RN55	341400
R53	Resistor, MF	15.0 k Ω , 1%	RN55	341417
R54	Not Used			
R55	Resistor, MF	30.1 k Ω , 1%	RN55	341446
R56	Resistor, MF	604 Ω , 1%	RN55	341275
R57	Resistor, MF	13.3 k Ω , 1%	RN55	341412
R58	Resistor, MF	8.87 k Ω , 1%	RN55	341391
R59	Resistor, MF	9.000 k Ω , 0.1%, 1/8W	PME55-T2	324354
R60	Resistor, MF	1.000 k Ω , 0.1%, 1/8W	PME55-T2	324241
R61	Resistor, MF	10.0 k Ω , 1%	RN55	341400
R62	Resistor, MF	1.0 k Ω , 1%	RN55	341300
R63*	Resistor, MF	26.7 k Ω , 1%	RN55	341441
R64	Resistor, MF	182 k Ω , 1%	RN55	341525
R65*	Resistor, MF	16.9 k Ω , 1%	RN55	341422
* When Option -01 is installed, these components are changed as follows:				
R63	Resistor, MF	13.0 k Ω , 1%	RN55	341411
R65	Resistor, MF	8.25 k Ω , 1%	RN55	341388
R66	Resistor, MF	73.2 k Ω , 1%	RN55	341483
R67	Resistor, Comp.	51 k Ω , 5%	01121 CB	343468
R68	Resistor, MF	48.7 k Ω , 1%	RN55	341466
R69	Resistor, MF	7.50 k Ω , 1%	RN55	341384
R70	Resistor, Comp.	51 k Ω , 5%	01121 CB	343468
R71*	Resistor, MF	9.53 k Ω , 1%	RN55	341394
R72	Resistor, Comp.	51 k Ω , 5%	01121 CB	343468
R73	Resistor, MF	1.54 k Ω , 1%	RN55	341318
R74	Resistor, MF	1.0 k Ω , 1%	RN55	341300
R75	Resistor, Comp.	100 k Ω , 5%	01121 CB	343500
R76	Resistor, MF	604 Ω , 1%	RN55	341275
R77	Resistor, Comp.	2 k Ω , 5%	01121 CB	343329
R78	Resistor, Comp.	510 k Ω , 5%	01121 CB	343568
R79	Resistor, Var.	1 k Ω , 10%, 0.5W	32997 3329H-1-102	311404
* When Option -01 is installed, this component changes as follows:				
R71	Resistor, MF	4.53 k Ω , 1%	RN55	341363
U1	Oper. Amplifier	LF356P	01295	535040
U2	Oper. Amplifier	NE5534AN	18324	535061
U3	Analog Switch	LF13333N	27014	535095
U4	D-A Converter	DAC-08EP	06665	421037
U5	Oper. Amplifier	NE5534AN	18324	535061
U6	Integrated Circuit	SN74LS00N	01295	534167
U7	Integrated Circuit	SN74121N	01295	534038
U8	Oper. Amplifier	LF356P	01295	535040
U9	Oper. Amplifier	TL074CN	01295	535082
U10	Integrated Circuit	CD4051BE	02735	534209
U11	Integrated Circuit	CD4051BE	02735	534209
U12	Oper. Amplifier	TL074CN	01295	535082
U13	Integrated Circuit	CD4052BE	02735	534140
U14	Oper. Amplifier	LF356P	01295	535040
U15	Integrated Circuit	CD4051BE	02735	534209

Table 5-2. Replaceable Parts (Continued)

Item	Description	Mfr.	Mfr's Part #	BEC Part #	
DIGITAL & POWER-SUPPLY BOARD ASSEMBLY (A4); PART NUMBER 082107					
C1	Capacitor, El.	10 μ F, 20%, 25V	S4217	SM25-VB-10M	283336
C2	Capacitor, Mica	47 pF, 5%, 300V		DM5-EC470J	205018
C3	Capacitor, El.	10 μ F, 20%, 25V	S4217	SM25-VB-10M	283336
C4	Capacitor, El.	10 μ F, 20%, 25V	S4217	SM25-VB-10M	283336
C5	Capacitor, Cer.	0.1 μ F, 20%, 25V	51406	DD312E10Y5P104M25V	224364
C6	Capacitor, Mica	1100 pF, 5%, 100V		DM15-112J	200111
C7	Capacitor, Cer.	0.1 μ F, 20%, 25V	51406	DD312E10Y5P104M25V	224364
C8	Capacitor, MPC	0.002 μ F, 2%, 50V	27735	MPC-53-.002-50-2	234140
C9	Capacitor, Cer.	0.001 μ F, 10%, 100V	04222	SR151C102KAA	224270
C10	Capacitor, Mica	1100 pF, 5%, 100V		DM15-112J	200111
C11	Capacitor, El.	10 μ F, 20%, 25V	S4217	SM25-VB-10M	283336
C12	Capacitor, Cer.	0.1 μ F, 20%, 25V	51406	DD312E10Y5P104M25V	224364
C13	Capacitor, Cer.	0.1 μ F, 20%, 25V	51406	DD312E10Y5P104M25V	224364
C14	Capacitor, Cer.	0.1 μ F, 20%, 25V	51406	DD312E10Y5P104M25V	224364
C15	Capacitor, Tant.	10 μ F, 20%, 25V	56289	196D106X0025KA1	283293
C16	Capacitor, Tant.	1.0 μ F, 20%, 35V	56289	196D105X9035HA1	283216
C17	Capacitor, Mylar	0.1 μ F, 10%, 100V	19701	C280MAH/A100K	234080
C18	Capacitor, Mylar	0.1 μ F, 10%, 100V	19701	C280MAH/A100K	234080
C19	Capacitor, El.	10 μ F, 20%, 25V	S4217	SM25-VB-10M	283336
C20	Capacitor, El.	10 μ F, 20%, 25V	S4217	SM25-VB-10M	283336
C21	Not Used				
C22	Not Used				
C23	Capacitor, El.	4700 μ F, 16V	57582	KSMM-4700-16	283352
C24	Capacitor, El.	2200 μ F, 35V	57582	KSMM-2200-35	283351
C25	Capacitor, El.	1000 μ F, 35V	57582	KSMM-1000-35	283350
C26	Capacitor, Cer.	0.1 μ F, 20%, 25V	51406	DD312E10Y5P104M25V	224364
C27	Capacitor, Cer.	0.1 μ F, 20%, 25V	51406	DD312E10Y5P104M25V	224364
C28	Capacitor, Cer.	0.1 μ F, 20%, 25V	51406	DD312E10Y5P104M25V	224364
C29	Capacitor, Cer.	0.001 μ F, 10%, 100V	04222	SR151C102KAA	224270
C30	Capacitor, Cer.	0.001 μ F, 10%, 100V	04222	SR151C102KAA	224270
C31	Capacitor, Mica	47 pF, 5%, 300V		DM5-EC470J	205018
C32	Capacitor, Tant.	10 μ F, 20%, 25V	56289	196D106X0025KA1	283293
C33	Capacitor, El.	100 μ F, 20%, 25V	S4217	SM25-VB-100M	283334
C34	Capacitor, Tant.	10 μ F, 20%, 25V	56289	196D106X0025KA1	283293
C35	Capacitor, Tant.	10 μ F, 20%, 25V	56289	196D106X0025KA1	283293
C36	Capacitor, Tant.	10 μ F, 20%, 25V	56289	196D106X0025KA1	283293
C37	Capacitor, Cer.	0.001 μ F, 10%, 100V	04222	SR151C102KAA	224270
CR1	Diode, Signal	1N914	01295		530058
CR2	Diode, Signal	1N914	01295		530058
CR3	Diode, Signal	1N914	01295		530058
CR4	Diode, Signal	FDH-300	07263		530052
CR5	Diode, Signal	FDH-300	07263		530052
CR6	Diode, Signal	1N914	01295		530058
CR7	Diode, Signal	1N914	01295		530058
CR8	Diode Bridge	VM-18	27777		532031
CR9	Diode Bridge	VM-18	27777		532031
CR10	Diode, Signal	1N4001	04713		530151
CR11	Diode, Signal	1N4001	04713		530151
CR12	Diode, Zener	1N5242B (12V)	04713		530146
CR13	Diode, Signal	1N4001	04713		530151
CR14	Diode, Zener	1N5242B (12V)	04713		530146
CR15	Diode, Signal	1N4001	04713		530151
CR16	Diode, Signal	1N4001	04713		530151
CR17	Diode, Signal	1N4001	04713		530151
CR18	Diode, Signal	1N4001	04713		530151
CR19	Diode, Signal	1N4001	04713		530151
CR20	Diode, Signal	1N4001	04713		530151
L1	Choke, R.F.	150 μ H, 5%	59474	1315-16J	400415
L2	Choke, R.F.	150 μ H, 5%	59474	1315-16J	400415
Q1	Transistor, NPN	2N3904	04713		528071
R1	Resistor, Comp.	22 k Ω , 5%	01121	CB	343433
R2	Resistor, Comp.	1 k Ω , 5%	01121	CB	343300
R3	Resistor, MF	10.0 k Ω , 1%		RN55	341400
R4	Resistor, Comp.	1 k Ω , 5%	01121	CB	343300
R5	Resistor, Comp.	1 k Ω , 5%	01121	CB	343300

Table 5-2. Replaceable Parts (Continued)

Item	Description	Mfr.	Mfr's Part #	BEC Part #
● DIGITAL & POWER-SUPPLY BOARD ASSEMBLY (A4), CONTINUED; PART NUMBER 082107 ●				
R6	Resistor, MF	14.0 k Ω , 1%		341414
R7	Resistor, Comp.	1 k Ω , 5%	01121	343300
R8	Resistor, Comp.	1 k Ω , 5%	01121	343300
R9	Resistor Network	3.3 k Ω , 2%, 1.5W	71450	345030
R10	Resistor, Comp.	1 k Ω , 5%	01121	343300
R11	Resistor, Comp.	330 Ω , 5%	01121	343250
R12	Resistor, Comp.	10 k Ω , 5%	01121	343400
R13	Resistor Network	3.3 k Ω , 2%, 1.5W	71450	345030
R14	Resistor Network	3.3 k Ω , 2%, 1.5W	71450	345030
R15	Resistor Network	3.3 k Ω , 2%, 2W	73138	345017
R16	Resistor Network	3.3 k Ω , 2%, 2W	73138	345017
R17	Resistor Network	22 Ω , 2%, 2W	73138	345034
R18	Resistor, MF	909 k Ω , 1%		342592
R19	Resistor, MF	100.0 k Ω , 1%		341500
R20	Resistor, Comp.	100 k Ω , 5%	01121	343500
R21	Resistor, Comp.	47 k Ω , 5%	01121	343465
R22	Resistor, Comp.	22 k Ω , 5%	01121	343433
R23	Resistor, Comp.	200 Ω , 5%	01121	343229
R24	Resistor, Comp.	200 Ω , 5%	01121	343229
R25	Resistor, Comp.	33 k Ω , 5%	01121	343450
R26	Resistor, Comp.	1 k Ω , 5%	01121	343300
R27	Resistor, Comp.	1 k Ω , 5%	01121	343300
R28	Resistor, Comp.	22 k Ω , 5%	01121	343433
R29	Resistor, Comp.	22 k Ω , 5%	01121	343433
R30	Resistor, Comp.	10 k Ω , 5%	01121	343400
R31	Resistor, Comp.	10 k Ω , 5%	01121	343400
R32	Resistor, MF	909 Ω , 1%		341292
R33	Resistor, MF	2.0 k Ω , 1%		341329
R34	Resistor, Comp.	360 Ω , 5%	01121	343253
R35	Resistor, Comp.	750 Ω , 5%	01121	343284
S1	Switch, DIP	7-section	71450	465215
U1	Integrated Circuit	SN74LS04N	01295	534155
U2	Oper. Amplifier	LF356N	01295	535040
U3	Integrated Circuit	CD4040BE	02735	534275
U4	Oper. Amplifier	LM311N	27014	535035
U5	Integrated Circuit	SN74LS74N	01295	534157
U6	Integrated Circuit	SN74LS32N	01295	534168
U7	A-D Converter	AD565AJD/BIN	24355	421034
U8	CPU	Z80-CPU-PS	56708	534159
U9	Integrated Circuit	SN74LS163AN	01295	534279
U10	Integrated Circuit	SN74LS42N	01295	534210
U11	EPROM		BEC	534284
U12	Integrated Circuit	SN74LS153N	01295	534278
U13	EPROM		BEC	534285
U14	RAM	P2111A-4	34649	534162
U15	RAM	P2111A-4	34649	534162
U16	Integrated Circuit	AM8255AAPC	34335	534171
U17	Integrated Circuit	AM8255AAPC	34335	534171
U18	Integrated Circuit	UDN2983A	56289	534255
U19	Transistor Array	ULN2803A	56289	534274
U20	Integrated Circuit	CD4051BE	02735	534209
U21	Oper. Amplifier	TL072CP	01295	535092
U22	Integrated Circuit	CD4052BE	02735	534140
U23	Oper. Amplifier	CA3080E	02735	535091
U24	Oper. Amplifier	CA3080E	02735	535091
U25	Voltage Regulator	MC78M05CT	04713	535046
U26	Voltage Regulator	μ A7805UC	04713	535011
U27	Voltage Regulator	MC78M05CT	04713	535046
U28	Voltage Regulator	μ A79M05AUC	04713	535093
U29	Oper. Amplifier	LM324N	27014	535068
Y1	Crystal	3.579 MHz	10236	547035
● DISPLAY BOARD ASSEMBLY (A5); PART NUMBER 082110 ●				
CR1	Diode, LED	HLMP-1401 (Yellow)	28480	536034
CR2	Diode, LED	HLMP-1301 (Red)	28480	536022
CR3	Diode, LED	HLMP-1301 (Red)	28480	536022

Table 5-2. Replaceable Parts (Continued)

Item	Description	Mfr.	Mfr's Part #	BEC Part #
● DISPLAY BOARD ASSEMBLY (A5), CONTINUED; PART NUMBER 082110 ●				
CR4	Diode, LED	HLMP-1301 (Red)	28480	536022
CR5	Diode, LED	HLMP-1301 (Red)	28480	536022
CR6	Diode, LED	HLMP-1301 (Red)	28480	536022
CR7	Diode, LED	HLMP-1301 (Red)	28480	536022
CR8	Diode, Signal	1N914	01295	530058
CR9	Diode, Signal	1N914	01295	530058
CR10	Diode, Signal	1N914	01295	530058
CR11	Diode, Signal	1N914	01295	530058
DS1	Display, Numeric	5082-7656	28480	536812
DS2	Display, Numeric	5082-7651	28480	536811
DS3	Display, Numeric	5082-7651	28480	536811
DS4	Display, Numeric	5082-7651	28480	536811
S1	Switch, Pushbutton	Type D7	31918	465287
S2	Switch, Pushbutton	Type D7	31918	465287
S3	Switch, Pushbutton	Type D7	31918	465287
S4	Switch, Pushbutton	Type D7	31918	465287
S5	Switch, Pushbutton	Type D7	31918	465287
S6	Switch, Pushbutton	Type D7	31918	465287
S7	Switch, Pushbutton	Type D7	31918	465287
S8	Switch, Pushbutton	Type D7	31918	465287
S9	Switch, Pushbutton	Type D7	31918	465287
S10	Switch, Pushbutton	Type D7	31918	465287
S11	Switch, Pushbutton	Type D7	31918	465287

SECTION VI
SCHEMATIC DIAGRAMS

TABLE OF CONTENTS

	PAGE
Figure 6-1: Main-Frame Schematic (E831193C, Sheet 1 of 4).....	6-3
Figure 6-2: I.F.-A.F. Board Schematic (E831193C, Sheet 3b of 4).....	6-3
Figure 6-3: I.F.-A.F. Board Schematic (E831193D, Sheet 3a of 4).....	6-5
Figure 6-4: R.F. Board Schematic (E831193D, Sheet 2 of 4).....	6-7
Figure 6-5: Digital and Power-Supply Board Schematic (R831193D, Sheet 4a of 4).....	6-9
Figure 6-6: Digital & Power-Supply Board Schematic (E831193D, Sheet 4b of 4).....	6-11
Figure 6-7: Digital & Power-Supply Board Schematic (D831193C, Sheet 4c of 4).....	6-13

NOTES

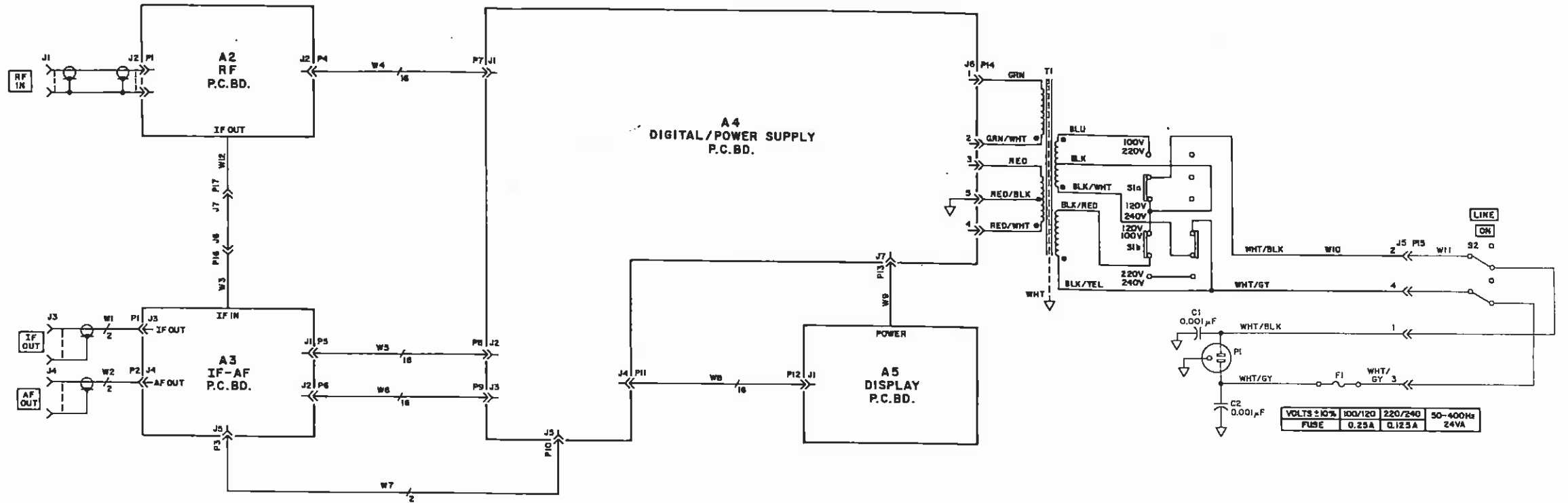
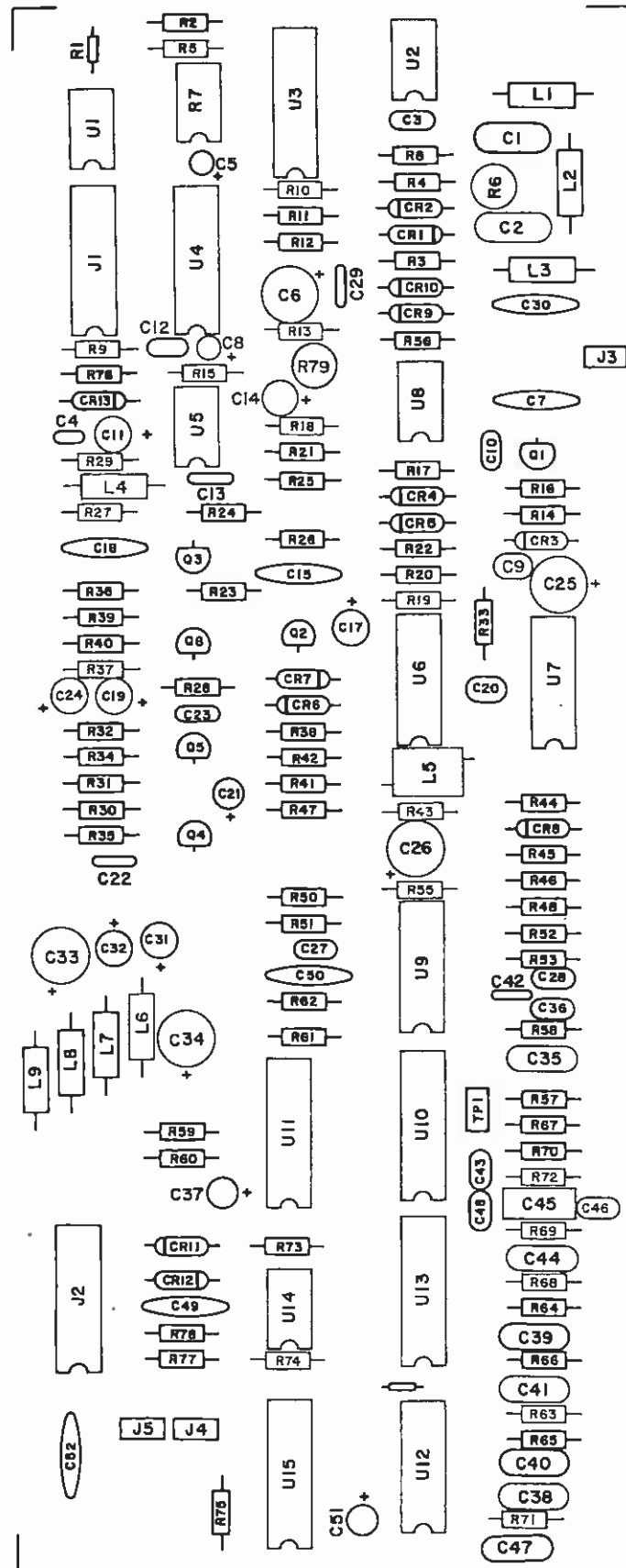

Figure 6-1.
Main-Frame Schematic
(E831193C, Sheet 1 of 4)

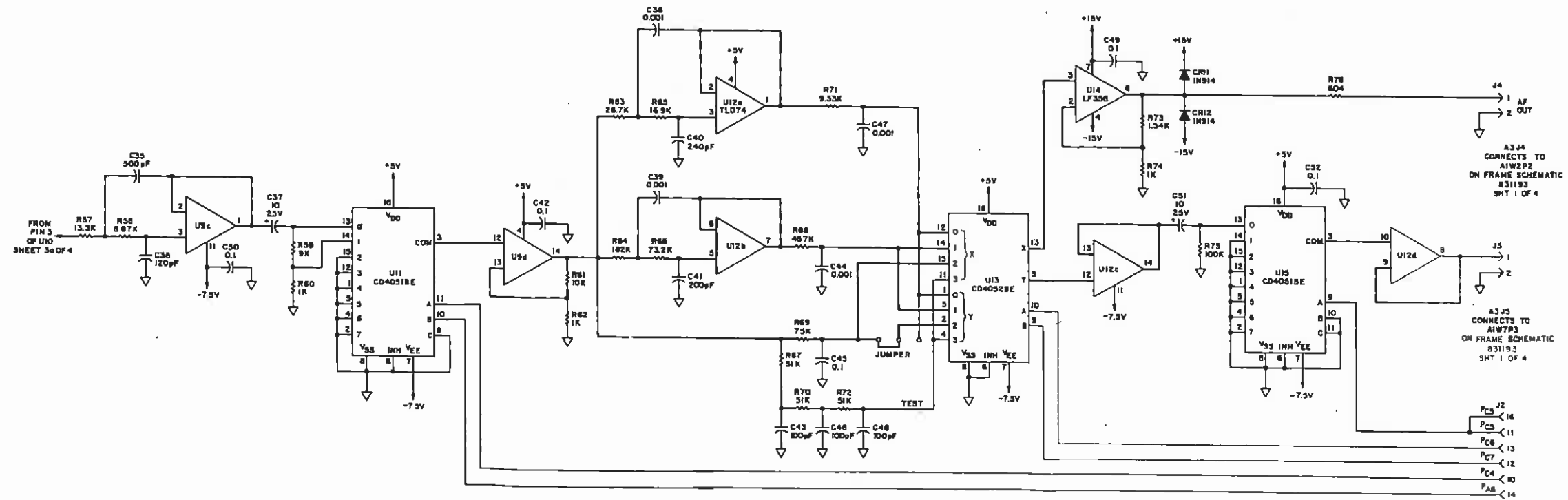
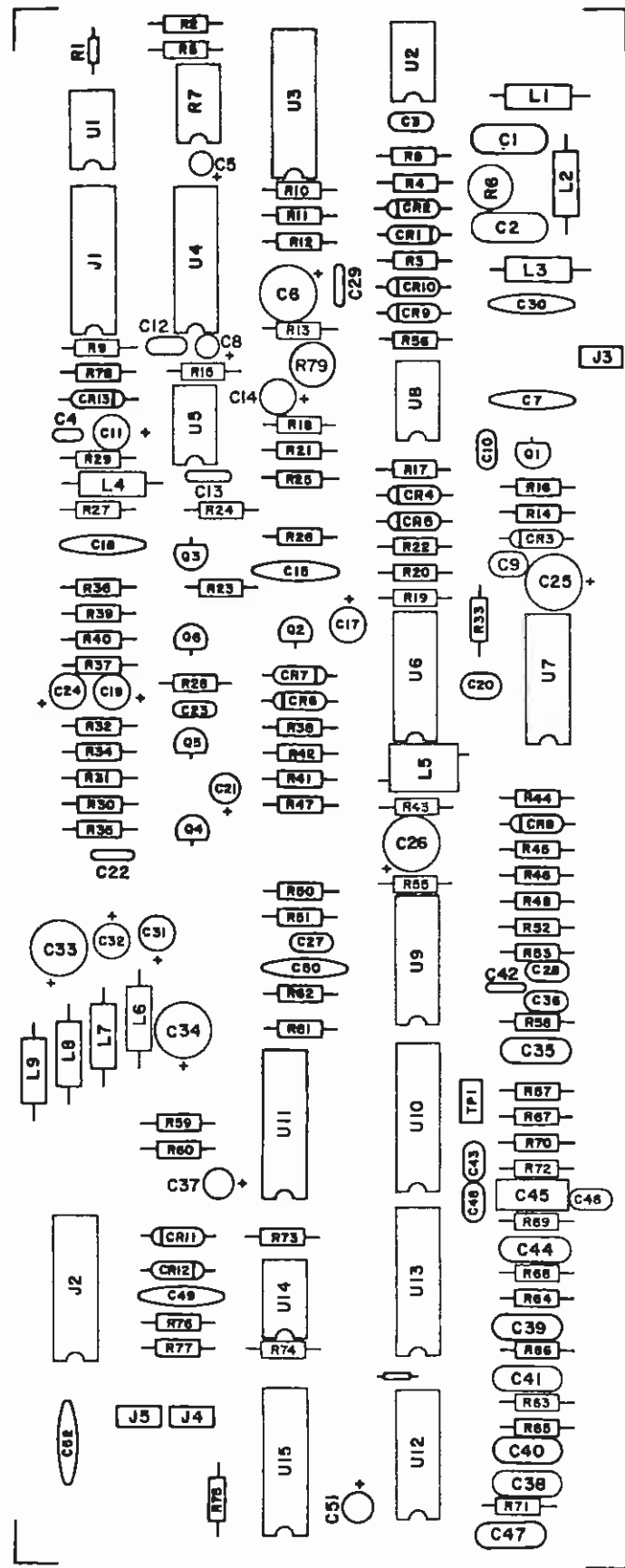
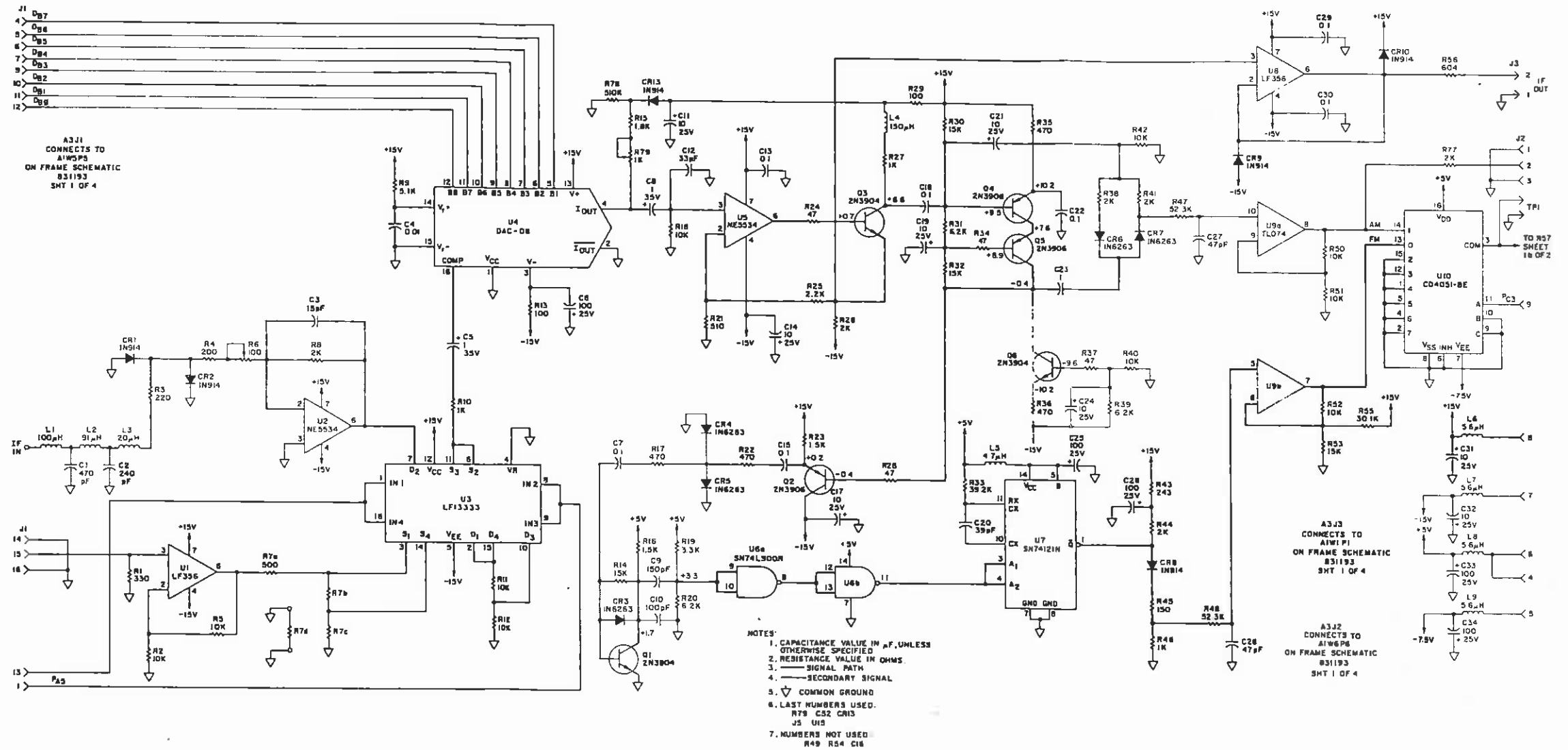

Figure 6-2.
I.F.-A.F. Board Schematic
(E831193C, Sheet 3b of 4)



A3 IF-AF P.C.B.D.



I.F.-A.F. Board Parts-Location Diagram (D831244C)

Figure 6-3.
I.F.-A.F. Board Schematic
(E831193D, Sheet 3a of 4)

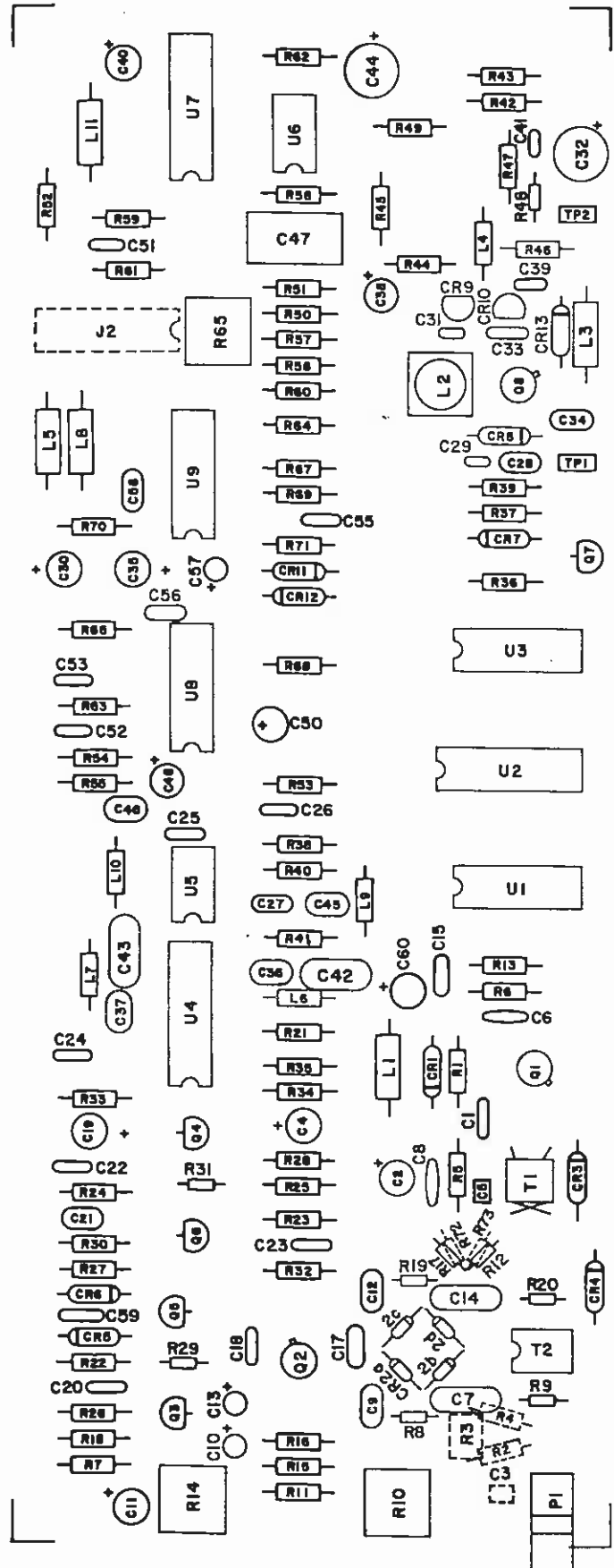

R.F. Board Parts-Location Diagram (D831245B)

A2 RF P.C.BD.

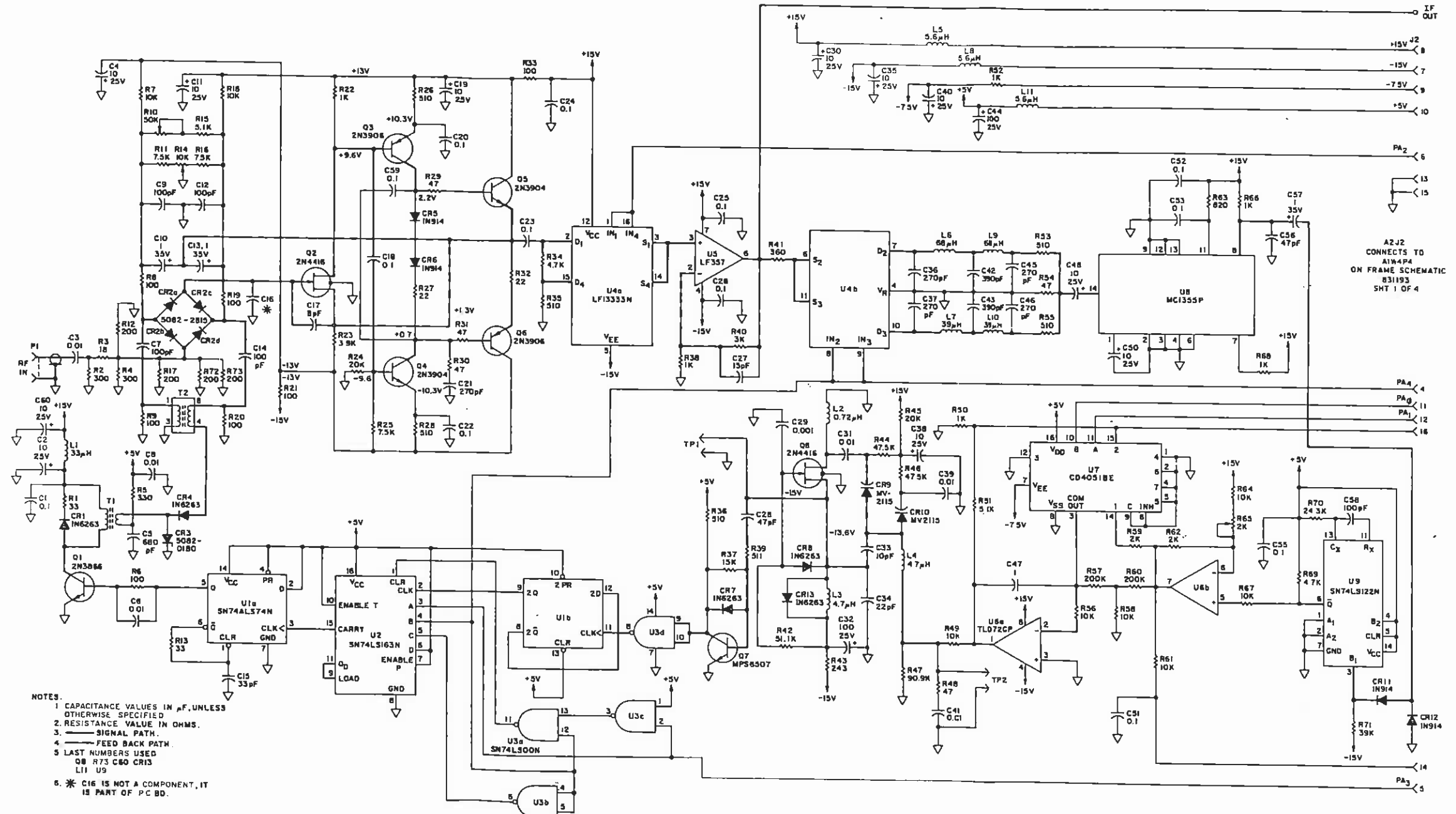

- NOTES:
1. CAPACITANCE VALUES IN μ F, UNLESS OTHERWISE SPECIFIED
 2. RESISTANCE VALUE IN OHMS.
 3. SIGNAL PATH.
 4. FEED BACK PATH.
 5. LAST NUMBERS USED
 6. * C16 IS NOT A COMPONENT, IT IS PART OF P.C.BD.

A2J2 CONNECTS TO A184P4 ON FRAME SCHEMATIC 831193 SHT 1 OF 4

Figure 6-4. R.F. Board Schematic (E831193D, Sheet 2 of 4)

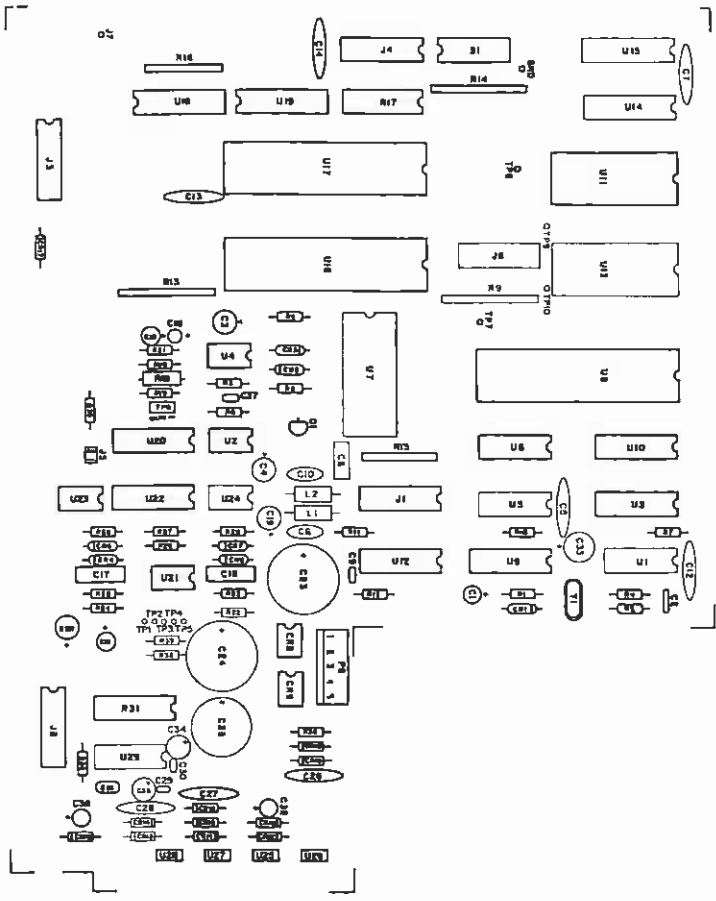

Digital & Power-Supply Board
Parts-Location Diagram (D831248C)

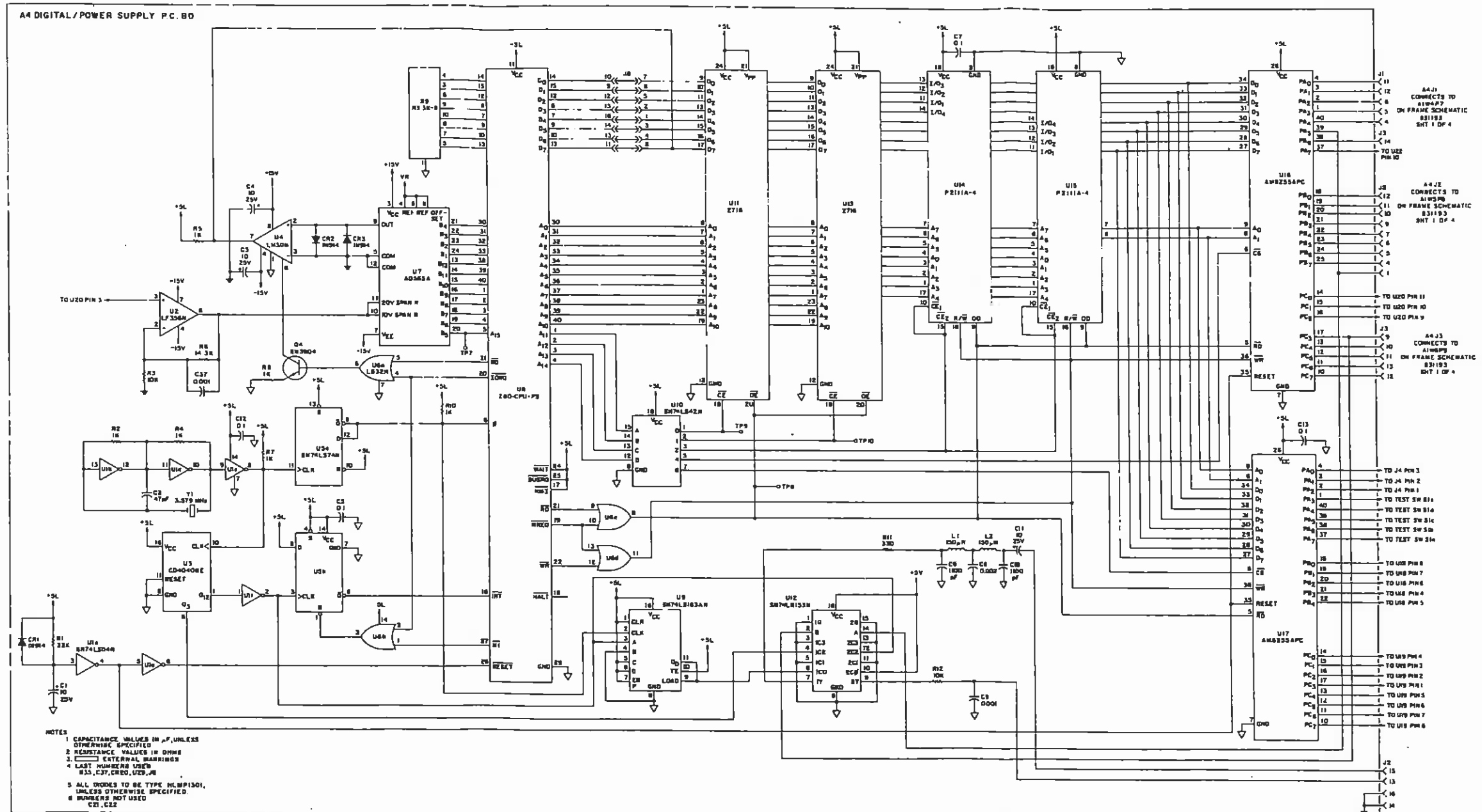
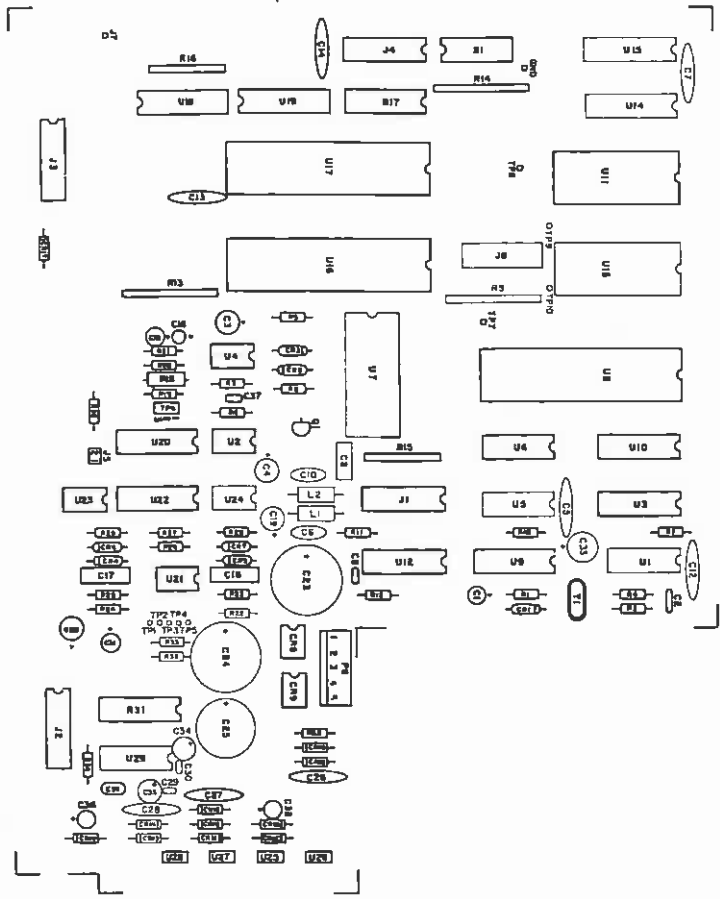
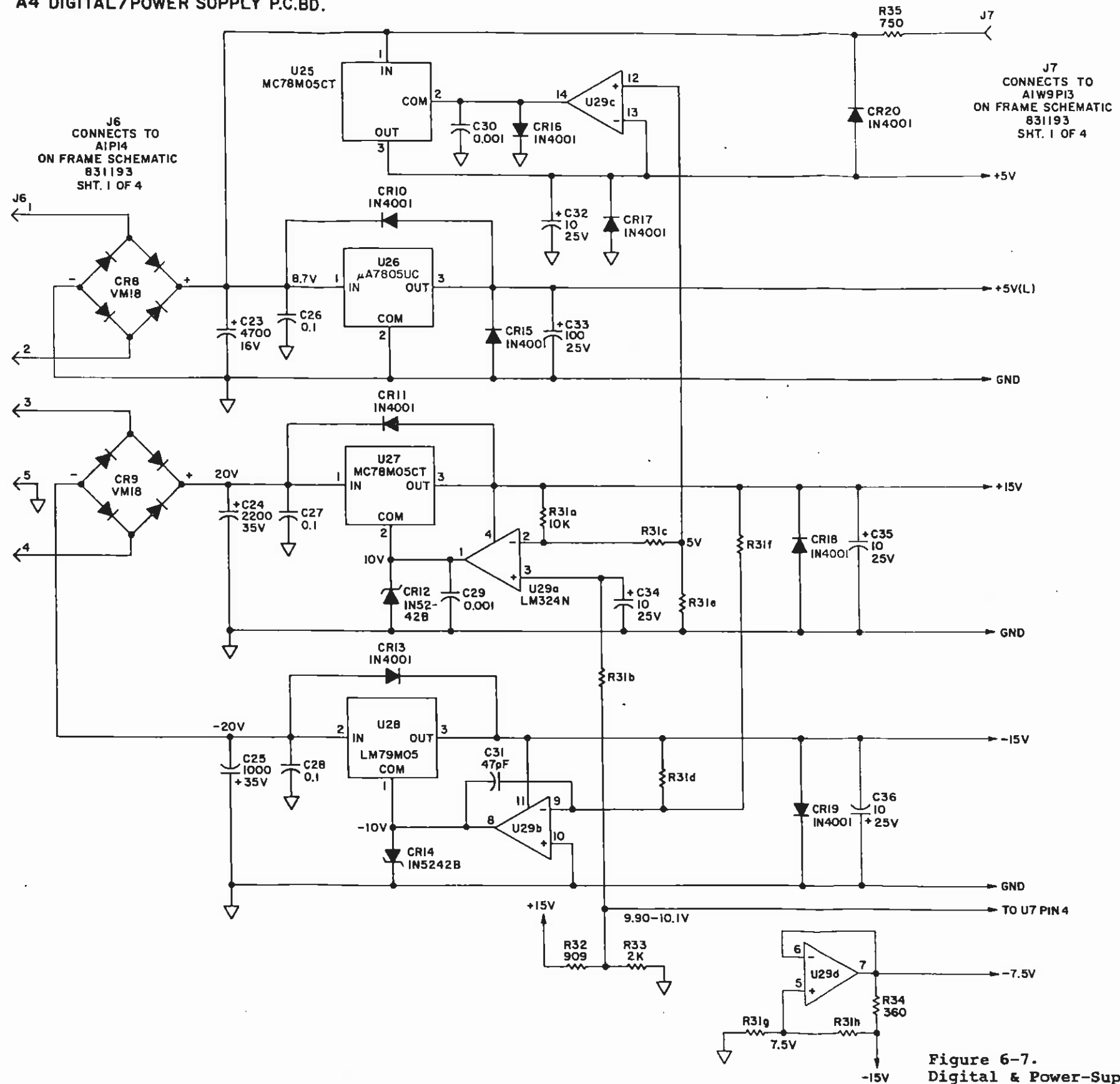

Figure 6-5.
Digital & Power-Supply Board
Schematic (R831193D, Sheet 4a of 4)

A4 DIGITAL/POWER SUPPLY P.C.BD.



Digital & Power-Supply Board
Parts-Location Diagram (D831248C)

Figure 6-7.
Digital & Power-Supply Board
Schematic (D831193C, Sheet 4c of 4)

APPENDIX A

CALIBRATOR OPERATION

A-1. INTRODUCTION

The internal calibrators of the Model 8210 provide modulation standards for a.m. and f.m. measurements; they are activated each time the instrument is turned on. This section of the manual provides technical information concerning the operation and design of the calibrators.

A-2. TECHNICAL DISCUSSION

a. F.M. Calibrator. The calibration process consists of (1st) applying to the f.m. discriminator, in alternation, two accurately controlled frequencies; (2nd) measuring the resulting recovered modulation information; and (3rd) computing a correction factor for subsequent f.m. measurements. As an aid in following this discussion refer to Figure 3-5.

- (1) The input signal to pin 2 of A4U9 is the microprocessor's crystal-oscillator signal divided by two: 1.79 MHz. The preset inputs, A - D, of A4U9 are alternately programmed to be 12 (decimal) or 13 (decimal), depending upon the sense of the signal on pin 3 of A4U9. This latter signal is generated by dividing the 3.58 MHz crystal-oscillator frequency by 4096. The resulting frequency is 874 Hz.
- (2) When the preset inputs are programmed to decimal 12, five clock cycles (i.e., at 1.79 MHz) are required to cause the counter to overflow. The Q_D output then goes low, which reloads the preset inputs. Under these conditions, the counter is dividing the signal by a factor of five, resulting in an output frequency of 357.9 kHz. Similarly, when the preset inputs are programmed to decimal 13, the counter divides by four. The resulting frequency is then 447.4 kHz. The "average" frequency, therefore, is 402.6 kHz. The peak-to-peak deviation is 89.5 kHz and peak deviation is 44.75 kHz.
- (3) To verify the accuracy of the f.m. calibrator, it is required only that the microprocessor's clock frequency be measured accurately. (Naturally, counter U9 must be operating properly as well.) Manual verification of the two (programmed) frequencies can be performed by lifting pin 2 of A4U9, shorting it alternately to +5 V and to ground, and measuring the resulting frequencies.
- (4) The calibration program accumulates ten readings, and averages them to eliminate the last-digit uncertainty. The voltmeter, however, can resolve the actual deviation only to 1 part in 447. Thus the worst-case quantizing error is $\pm 0.22\%$. F.M. noise is of little or no consequence in determining calibrator deviation, since the two frequencies are crystal controlled and the r.f. circuitry is bypassed for calibration.
- (5) Cross-correlation measurements using a Bessel null technique indicate that the actual calibration uncertainty for 100 calibrations is close to $\pm 0.11\%$, or one-half digit. (When employing Bessel null correlation, care should be taken to use a carrier with the lowest possible noise--and to take noise residuals into account--while keeping audio distortion to less than 0.1%.)

b. A.M. Calibrator. The operation of the a.m. calibrator is similar to that of the f.m. calibrator. Refer to Figure 3-5.

- (1) During a.m. calibration the count modulus of A4U9 is fixed at four. The resulting frequency, 447.5 kHz, is low-pass filtered by A4L1, L2, C6, C8 and C10 to remove harmonics. The signal's amplitude is

not critical since the a.g.c. system is used to normalize the a.m. detector output.

- (2) The filtered signal is routed to the i.f.-a.f. circuit board via C11, which removes any d.c. component, and thence to the input of buffer U1. Amplifier U1 increases the level of the signal, and more importantly, provides a very low output impedance to drive the voltage divider consisting of A3R7a, b, and c. The signal is kept at a high level in its passage through A3U3 in order to reduce the effects of switching transients and feed-through. The attenuator consisting of R11 & R12 reduces the signal to the correct level after modulation.
- (3) The voltage divider comprising A3R7a, b, c, is a precision-resistor array. The absolute value of the resistors, however, is not as important as is the match between them. Thus, resistors R7b and R7c are guaranteed to a $\pm 0.1\%$ match with R7a.

Maintaining this voltage divider at a constant impedance minimizes the loading effect of attenuator A3R11-R12.

- (4) The voltage at the junction of A3R7a and R7b is two-thirds of the output voltage of A3U1; the voltage at the junction of R7b and R7c is one-third. The ratio of these two voltages is 2:1. The equivalent a.m. percentage is then derived as follows:

NOTE:
 $P_+ = +\text{peak}$
 $P_- = -\text{peak}$

$$\% p_+ = \frac{E_{\max} - E_{\text{avg}}}{E_{\text{avg}}} \times 100 \quad (1)$$

$$\% p_- = \frac{E_{\text{avg}} - E_{\min}}{E_{\text{avg}}} \times 100 \quad (2)$$

$$\text{peak average } \% = \frac{P_+ - P_-}{2} \times 100 \quad (3)$$

Therefore, combining Eqs. 1, 2 & 3, for symmetrical modulation,

$$\% \text{ a.m.} = \frac{E_{\max} - E_{\min}}{E_{\max} + E_{\min}} \times 100 \quad (4)$$

And for a 2:1 ratio,

$$= \frac{2 - 1}{2 + 1} \times 100$$

$$= 33.33\%$$

- (5) The above equations assume that the modulation is symmetrical (i.e. perfectly so). Should that not be the case, a d.c. shift occurs and the plus and minus peaks are not symmetrical. The calibrator program eliminates such an error by calculating a.m. as:

$$\text{peak average} = \frac{P_+ + 2P_-}{3} \quad (5)$$

This expression is determined as follows:

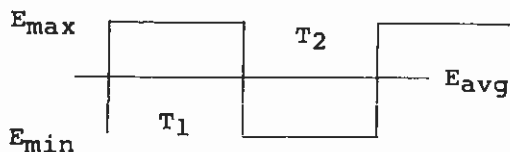

Symmetric (Ideal) Modulation

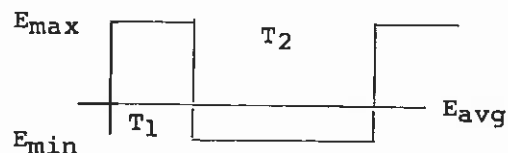

Asymmetric Modulation

Calibrator Modulation Signal

¶A-2b(5), Continued.

Now, since the peak detectors are a.c. coupled,

$$(p_+)(T_1) - (p_-)(T_2) = 0 \quad (0 \text{ volts, d.c.}) \quad (6)$$

And: $T_1 + T_2 = 1 \quad (7)$

$$(p_+)(T_1) - (p_-)(1 - T_1) = 0 \quad (8)$$

$$T_1 = \frac{p_-}{p_+ + p_-} \quad (9)$$

Now: $E_{avg} = E_{min} + (E_{max} - E_{min}) \frac{T_1}{T_1 + T_2} \quad (10)$

And, in the 8210:
[see ¶A-2b(4)] $E_{max} = 2E_{min} \quad (11)$

Combining Eqs. 7, 10 & 11: $E_{avg} = E_{min} + E_{min} (T_1) \quad (12)$

$$E_{avg} = E_{min} (1 + T_1) \quad (13)$$

If symmetry is perfect: $E_{avg} = E_{min} (1.5) \quad (14)$

If symmetry is less than perfect, the d.c. ratio error, R (that is, Eq. 13 vs. Eq. 14), will be:

$$R = (1 + T_1)/1.5 \quad (15)$$

Combining Eqs. 9 & 15: $R = \frac{p_+ + 2 p_-}{1.5 (p_+ + p_-)} \quad (16)$

The uncorrected a.m.,
(E_{avg} normalized to 1): $= \frac{p_+ + p_-}{2} \quad (17)$

The corrected a.m. is then: $= \frac{p_+ + p_-}{2} \times R \quad (18)$

And, from Eqs. 16 & 18, $= \frac{p_+ + 2p_-}{3} \quad (19)$

(6) It should be noted that only the ratio of the two modulating levels is important--not their absolute values. The two a.m. levels can be measured at the AF OUT connector by manually operating the IC analog switch A3U3 as follows:

- (a) With power off, set Pos. #7 of Test Switch A4S1 "on."
- (b) Power on. Connect a voltmeter to the AF OUT connector.
- (c) Connect a clip lead from pin 1 or 16 of A3U3 to ground. (These pins are resistively isolated, so no harm will occur in grounding them.)
- (d) Depress the AM FUNCTION button and measure the AF OUT voltage.
- (e) Disconnect the clip lead from ground and connect it to +5 volts (pin 14 of A3U6).
- (f) Measure the AF OUT voltage.

The ratio of the two voltages should be exactly 2:1, within $\pm 0.1\%$ (The voltmeter should be able to resolve a 0.1% error at 447.4 kHz; a thermocouple type is suggested.)

The procedure given above is not intended to be a performance test;

it is included only to satisfy one who is curious as to the operation of the calibrator.

- (7) The calibration program accumulates ten readings, and averages them to eliminate the last-digit uncertainty in the scaling operation. The voltmeter, however, can resolve the reading only to 1 part in 333. Therefore, the worst-case quantification error is $\pm 0.3\%$. A.M. noise is of little consequence in determining calibrator depth since the level is determined by TTL gates before filtering, and the frequency is crystal-controlled. Actual noise levels are less than 1 part in 3333.
- (8) Cross-correlation measurements using a specially calibrated Model 82AD F.M.-A.M. Modulation Meter (Boonton Electronics) indicate that the actual calibration uncertainty for 100 calibrations is approximately $\pm 0.15\%$.

c. Audio Processing. During calibration, a three-pole gaussian filter is used to remove high-frequency signal components. The filter time-constants are selected so as to provide the required filtering without affecting the absolute peak values of the recovered signal. The use of a gaussian filter ensures that there will be no overshoot on the recovered audio signal.

d. R.F. Circuitry. The Model 8210's r.f. circuitry is designed to have exceptional linearity so that a.m. performance is not degraded. As noted earlier, however, the r.f. circuits are not included in the modulation-calibration process. Consequently, during a.m. measurements, errors can occur if there is a malfunction in the r.f. section. These errors will usually be obvious to the user.

For f.m. measurements, the bypassing of r.f. circuitry during modulation calibration does not present a problem, since frequency modulation is the same before and after frequency conversion.

T.O. 33K3-4-3070-1

TECHNICAL MANUAL
CALIBRATION PROCEDURE
FOR
MODULATION METER
8210, 8210-01-S/3

(BOONTON)



This publication replaces T.O. 33K3-4-3070-1 dated 30 May 1997 and all subsequent changes.

Distribution Statement - Distribution authorized to U.S. Government agencies and their contractors for official use or for administrative or operational purposes only, 30 May 1997. Other requests for this document shall be referred to AFMETCAL Detachment 1/MLLW, 813 Irving-Wick Dr W, Suite 4M, Heath, OH 43056-6116.

Destruction Notice - For unclassified, limited documents, destroy by any method that will prevent disclosure of the contents or reconstruction of the document.

Published under Authority of the Secretary of the Air Force

30 AUGUST 1999

T.O. 33K3-4-3070-1

LIST OF EFFECTIVE PAGES

INSERT LATEST CHANGED PAGES. DESTROY SUPERSEDED PAGES.

NOTE: The portion of the text and illustrations affected by the changes is indicated by a vertical line in the outer margins of the page.

Dates of issue for original and changed pages are:

Original 0 30 August 1999

TOTAL NUMBER OF PAGES IN THIS PUBLICATION IS 22, CONSISTING OF THE FOLLOWING:

Page No.	* Change No.	Page No.	* Change No.	Page No.	* Change No.
Title.....	0				
A.....	0				
1 - 19.....	0				
20 Blank.....	0				

* Zero in this column indicates an original page

MODULATION METER

8210, 8210-01-S/3

(BOONTON)

1 CALIBRATION DESCRIPTION:

Table 1.

Test Instrument (TI) Characteristics	Performance Specifications	Test Method
Carrier Level Sensitivity	Range: 2 MHz to 1500 MHz Accuracy: 10 mV (-27 dBm) from 2 MHz to 520 MHz; 30 mV (-17.4 dBm) from 520 to 1500 MHz:	Known Signal applied
FM Modulation (8210)	Range: Rates <30 Hz to 15 kHz Range 0 to 150 kHz peak Accuracy: * $\pm 1\%$ of reading for rates 50 Hz to 5 kHz: * $\pm 2\%$ of reading for 5 to 7.5 kHz:	Compared to a Modulation Analyzer.
* Note Peak residuals must be accounted for to obtain the above accuracy.		
FM Modulation (8210-01)	Range: Rates <30 Hz to 30 kHz Range 0 to 150 kHz peak Accuracy: * $\pm 1\%$ of reading for rates 50 Hz to 10 kHz: * $\pm 2\%$ of reading for 10 to 15 kHz:	Compared to a Modulation Analyzer.
* Note Peak residuals must be accounted for to obtain the above accuracy.		
Residual FM (RF Level >100 mV) (8210)	Range: 2 to 1500 MHz Accuracy: 3 kHz Low Pass filter: <150 Hz rms at 1500 MHz linear decreasing to floor of <5 Hz rms 15 kHz Low Pass Filter: <200 Hz rms at 1500 MHz linear decreasing to floor of <15 Hz rms	CW Signal applied and residual FM measured

Table 1. (Cont.)

Test Instrument (TI) Characteristics	Performance Specifications	Test Method
Residual FM (RF Level >100 mV) (8210-01)	Range: 2 to 1500 MHz Accuracy: 3 kHz Low Pass filter: <150 Hz rms at 1500 MHz linear decreasing to floor of <5 Hz rms 30 kHz Low Pass Filter: <400 Hz rms at 1500 MHz linear decreasing to floor of <25 Hz rms	CW Signal applied and Residual FM measured
AM Rejection	Range: 50% AM Depth, 3 kHz Low Pass Accuracy: <100 Hz deviation at 50% AM Modulation (1 kHz rate) (FM Residual subtracted)	Known AM signal applied and FM Signal Measured
FM Distortion	Range: 75 kHz deviation 50 to 10 kHz rate Accuracy: <0.25% THD	Known signal applied and distortion measured
AM Modulation (8210)	Range: 0 to 100% at Rates, 50 Hz to 7.5 kHz Accuracy: **	Compared to Modulation Analyzer
	Modulation Rate 10% to 90% * 50 Hz to 5 kHz 1% of reading * 5 kHz to 7.5 kHz 2% of reading	<10% & 90% 3% of reading 6% of reading
* Note: Peak residuals must be accounted for to obtain the above accuracy; ** Note: Carrier frequency <520 MHz; with RF levels between -10 and -10 dBm.		
AM Modulation (8210-01)	Range: 0 to 100% at Rates, <30 Hz to 30 kHz Accuracy: **	Compared to Modulation Analyzer
	Modulation Rate 10% to 90% * 50 Hz to 10 kHz 1% of reading * 10 kHz to 15 kHz 2% of reading	<10% & 90% 3% of reading 6% of reading
* Note: Peak residuals must be accounted for to obtain the above accuracy; ** Note: Carrier frequency <520 MHz; with RF levels between -10 and -10 dBm.		

Table 1. (Cont.)

Test Instrument (TI) Characteristics	Performance Specifications	Test Method
Residual AM (RF Level >100 mV) (8210)	Range: 2 to 1500 MHz Accuracy: ** 3 kHz Low Pass filter: <0.15% AM, rms <520 MHz carrier ** 15 kHz Low Pass Filter: <0.25% AM, rms <520 MHz Carrier	CW Signal applied and Residual AM measured
** Note: Above 520 MHz carrier frequency the AM Residuals increase linearly with frequency		
Residual AM (RF Level >100 mV) (8210-01)	Range: 2 to 1500 MHz Accuracy: ** <0.15% AM, rms <520 MHz Carrier ** 30 kHz Low Pass Filter: <0.35% AM, rms <520 MHz Carrier	CW Signal applied and residual FM measured
** Note: Above 520 MHz carrier frequency the AM Residuals increase linearly with frequency		
FM Rejection	Range: To 150 kHz deviation Accuracy: <1.0% AM peak	Known FM signal applied AM modulation measured
AM Distortion	Range 0 to 90% depth 50 Hz to 10 kHz rate Accuracy: ≤0.5%	Distortion measured with Audio Analyzer
Audio Filters (8210)	Range: Lowpass 3 kHz, 15 kHz De-emphasis 750 μs Accuracy: ±4% 3 dB corner and time constant	Pass frequency set and corner deviation limits measured
Audio Filters (8210-01)	Range: Lowpass 3 kHz, 30 kHz De-emphasis 750 μs Accuracy: ±4% 3 dB corner and time constant	Pass frequency set and corner deviation limits measured

2 EQUIPMENT REQUIREMENTS:

Noun	Minimum Use Specifications	Calibration Equipment	Sub-Item
2.1 SIGNAL GENERATOR	Range: 0.01 to 1500 MHz Accuracy: $\pm 5 \times 10^{-10}$	Hewlett-Packard 8663A Opt 001-002	As Avail.
2.2 TEST OSCILLATOR	Range: 1 MHz to 18 MHz Accuracy: $\pm 1\%$	Hewlett-Packard 3325A	
2.3 AUDIO ANALYZER	Range: 20 Hz to 40 kHz 0 to 3 Vrms Accuracy: $\pm 3\%$ Flatness	Hewlett-Packard 8903B	As Avail.
2.4 DIGITAL VOLTMETER	Range: DC 0 to +12 VDC AC 0 to 3 Vrms Accuracy: DC $\pm 1\%$ AC $\pm 0.1\%$	Hewlett-Packard 3458A	
2.5 MODULATION ANALYZER	Range: FM Deviation 0 to 200 kHz, Rate 20 to 50 kHz AM Depth 0 to 100% Accuracy: FM Deviation; $\pm 2.0\%$ AM Depth; 2.0%	Hewlett-Packard 8901A/B	
2.6 POWER SPLITTER	Range: 2 to 1500 MHz Accuracy: N/A	Hewlett-Packard 11667A	

3 PRELIMINARY OPERATIONS:

3.1 Review and become familiar with the entire procedure before beginning Calibration Process.

WARNING

Unless otherwise designated, and prior to beginning the Calibration Process, ensure that all test equipment voltage and/or current outputs are set to zero (0) or turned off, where applicable. Ensure that all equipment switches are set to the proper position before making connections or applying power.

3.2 The TI may be equipped with one or more of the following options:

A. Option 01, 30 kHz Low Pass Filter. The standard 15 kHz Low Pass Filter is replaced with a 30 kHz Low Pass Filter.

B. Option S/3, Alkaline Battery internal Power Pack. The TI has an internal Alkaline battery pack.

3.3 Apply power to Test Equipment and allow a 10 minutes warm-up period.

3.5 SELF TEST CALIBRATION CHECKS:

3.5.1 Press and hold the LEVEL switch while pressing the TI LINE switch to the ON position, then release the LEVEL switch. The TI display will indicate CAL which means an internal calibration procedure has begun.

3.5.2 Calibration takes approximately 30 seconds and no errors should be displayed. If any errors are noted, TI should be repaired using proper maintenance documents before proceeding with calibration.

NOTE

When the TI as no signal applied or the signal applied is below the level required for a measurement the TI display will show a series of dashes to indicate an UNLOCKED condition. The presence of a measurement value indicates a LOCKED condition. If a signal is applied that requires a Automatic Gain Control (AGC) cycle the TI LED display shows two dashes. The two dashes is not an UNLOCK condition, but a normal indication of automatic operation.

3.5.3 After calibration completes a series of dashes should appear on the LED to indicated the TI is in a unlocked condition.

3.5.4 Complete a TI preliminary functional check as follows:

3.5.4.1 Connect Test Oscillator to TI RF IN 50 Ω connector.

3.5.4.2 Set Test Oscillator for a 15 MHz -7 dBm (100 mVrms) CW signal to the TI. The TI LED display should indicate the residual modulation.

3.5.4.3 Reduce Test Oscillator output amplitude to -33 dBm (5 mVrms). Verify the TI display indicates IFLO.

3.5.4.4 Increase Test Oscillator output amplitude to +17 dBm (1.59 Vrms). Verify the TI display indicates IFHI.

3.5.4.5 Set Test Oscillator output amplitude to 0 dBm (224 mVrms).

3.5.4.6 Depress in turn the three FILTERS switches, and verify the correct annunciator light.

3.5.4.7 Depress in turn the three FUNCTION switches, and verify the correct annunciator light.

3.5.4.8 Depress in turn the three PEAK switches, and verify the correct annunciator light. A plus sign (+) will be shown for the + PEAK switch, a minus sign (-) for -PEAK, and no sign when the AVG switch is depressed.

3.5.4.9 Depress each RANGE switch and verify the decimal point moves right or left as each switch is depressed.

3.5.4.10 Set Test Oscillator output to OFF and disconnect from TI.

3.5.4.11 Connect Signal Generator RF OUT connector to TI RF IN 50 Ω connector.

3.5.4.12 Set Signal Generator for a 15 MHz signal with a 0 dBm (224 mVrms) level. Set for AM modulation with a 1 kHz rate and a 50% depth.

3.5.4.13 Depress the TI AM FUNCTION, the 100 SCALE, and the 15 kHz FILTER switches. Verify the TI LED display indicates approximately 50% AM modulation.

T.O. 33K3-4-3070-1

3.5.4.14 Set Signal Generator AM modulation OFF. Set Signal Generator for FM modulation at a 1 kHz rate and a 50 kHz peak deviation.

3.5.4.15 Depress TI FM FUNCTION switch, and verify the TI LED display indicates approximately 50 kHz Deviation.

3.5.4.16 Set Signal Generator RF output to OFF, and disconnect equipment.

3.6 Perform only the sections of this procedure applicable to the TI being calibrated.

4 CALIBRATION PROCESS:

NOTE

Unless otherwise specified, verify the results of each test and take corrective action whenever the test requirement is not met, before proceeding.

4.1 CARRIER LEVEL SENSITIVITY CALIBRATION:

4.1.1 Connect Signal Generator RF OUT connector to the TI RF IN 50Ω connector.

4.1.2 Depress the TI switches as follows:

FILTERS	15 kHz (8210) 30 kHz (8210-01)
PEAK	AVG
FUNCTION	FM
RANGE	100

4.1.3 Set Signal Generator for a 10 MHz CW output with a level of -27 dBm (10 mVrms).

4.1.4 The TI must indicate a LOCKED condition that the TI will make a measurement at the 10 mVrms level.

4.1.5 Set Signal Generator for a 500 MHz CW output with a level of -27 dBm (10 mVrms).

4.1.6 The TI must indicate a LOCKED condition that the TI will make a measurement at the 10 mVrms level.

4.1.7 Set Signal Generator for a 1500 MHz CW output with a level of -17.4 dBm (30 mVrms).

4.1.8 The TI must indicate a LOCKED condition that the TI will make a measurement at the 30 mVrms level.

4.2 FM RESIDUAL AND AM RESIDUAL CALIBRATION:

4.2.1 Connect equipment as shown in Figure 1.

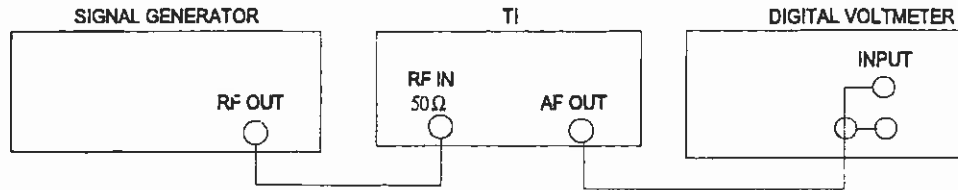

Figure 1.

4.2.2 Depress the TI switches as follows:

FILTERS	15 kHz (8210) 30 kHz (8210-01)
PEAK	AVG
FUNCTION	FM
RANGE	10

4.2.3 Set Signal Generator for a 500 MHz CW output with a level of 0 dBm (224 mVrms).

4.2.4 Set Digital Voltmeter as required for a AC measurement with a bandpass width of 5 Hz to 100 kHz. Verify the Digital Voltmeter indication (FM Residual) is less than 13.3 mV (26.6 for 8210-01).

4.2.5 Record the TI residual FM indication for the 15 kHz Low Pass filter (30 kHz for TI 8210-01).

4.2.6 Depress TI 3 kHz FILTER.

4.2.7 Verify the Digital Voltmeter indication is less than 10 mV.

4.2.8 Record the TI residual FM indication for the 3 kHz Low Pass filter.

4.2.9 Depress TI AM FUNCTION switch.

4.2.10 Set Digital Voltmeter as required for an AC measurement with a bandpass width of 5 Hz to 100 kHz. Verify the Digital Voltmeter indication (AM residual) is less than 30.0 mV.

4.2.11 Depress TI 15 kHz (30 kHz for TI 8210-01) FILTER.

4.2.12 Verify the TI residual AM indication for the 15 kHz (30 kHz for TI 8210-01) Low Pass filter is less than 50 mV (70 mV for 8210-01).

4.3 FM MODULATION DEVIATION ACCURACY CALIBRATION:

4.3.1 Connect the equipment as shown in Figure 2.

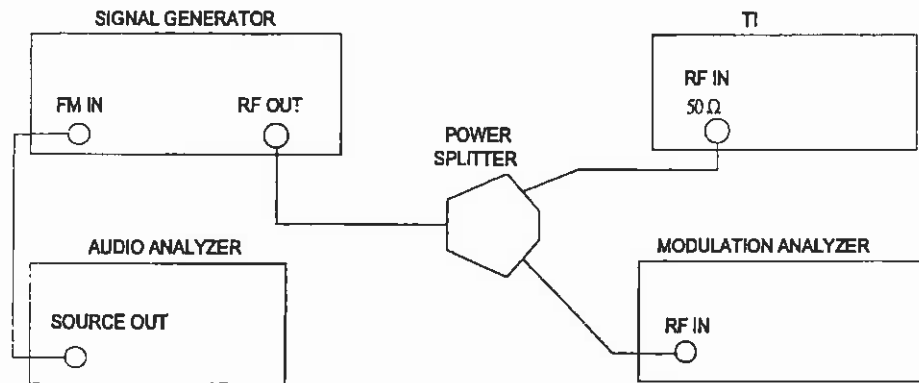

Figure 2.

4.3.2 Set the Signal Generator for 500 MHz at +3 dBm, FM to 100 kHz deviation and EXT DC.

4.3.3 Depress the TI switches as follows:

FILTERS	15 kHz (8210) 30 kHz (8210-01)
PEAK	AVG
FUNCTION	FM
RANGE	100

4.3.4 Set Modulation Analyzer MEASUREMENT to FM, DETECTOR to PEAK+, HP FILTER to OFF and LP FILTER to >20 kHz.

4.3.5 Adjust Audio Analyzer for a output frequency of 1 kHz, and adjust output amplitude for a Modulation Analyzer FM indication of 100 kHz deviation.

4.3.6 Subtract the TI residual FM value recorded in step 4.2.5 from the the TI indicated value.

4.3.7 Verify the calculated value from 4.3.6 is 99 to 101 kHz.

4.3.8 Set Audio Analyzer frequency, TI SCALE, Signal Generator Deviation, as listed in Table 2.

Table 2.

Audio Analyzer (Hz)	Signal Generator (Deviation kHz)	TI SCALE	Modulation Analyzer (kHz)	TI Limits (kHz)
8210				
1 k	100	100	100	99.0 to 101.0 *
50	100	100	100	99.0 to 101.0 *

Table 2. (Cont.)

Audio Analyzer (Hz)	Signal Generator (Deviation kHz)	TI SCALE	Modulation Analyzer (kHz)	TI Limits (kHz)
4.9 k	100	100	100	99.0 to 101.0 *
5.1 k	100	100	100	98.0 to 102.0 *
7.5 k	100	100	100	98.0 to 102.0 *
1 k	10	10	10	9.90 to 10.1 *
8210-01				
1 k	100	100	100	99.0 to 101.0 *
50	100	100	100	99.0 to 101.0 *
5.0 k	100	100	100	99.0 to 101.0 *
7.5 k	100	100	100	99.0 to 101.0 *
9.9 k	100	100	100	99.0 to 101.0 *
10.1 k	100	100	100	98.0 to 102.0 *
15.0 k	100	100	100	98.0 to 102.0 *
1 k	10	10	10	9.90 to 10.1 *

* Peak residuals must be accounted for to obtain the listed Accuracy.

4.3.9 Set Audio Analyzer and Signal Generator RF Outputs to OFF and disconnect the test setup.

4.4 AM REJECTION CALIBRATION:

4.4.1 Connect equipment as shown in Figure 3.

4.4.2 Set the Signal Generator for a 30 MHz at 0 dBm, AM to 30% and EXT DC.

4.4.3 Depress the TI switches as follows:

FILTERS	3 kHz
PEAK	AVG
FUNCTION	AM
RANGE	100

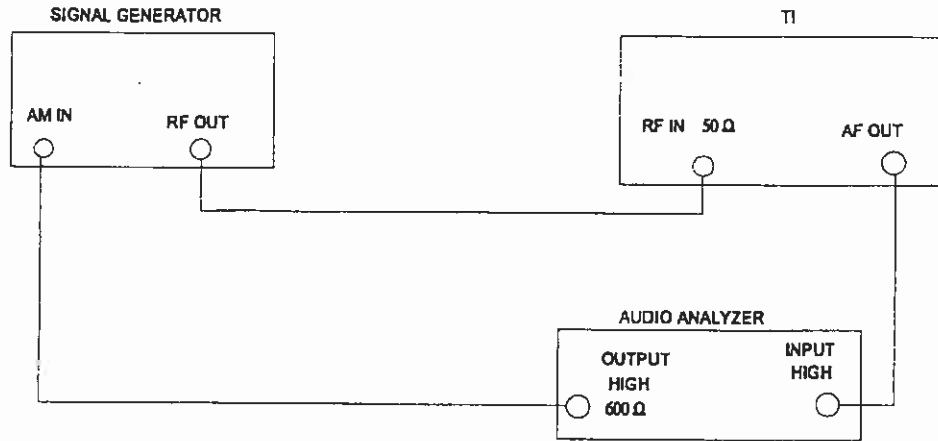

Figure 3.

4.4.4 Set Audio Analyzer for a 600 Ω source output (47.0 Special). Set for a output frequency of 1 kHz, and adjust output amplitude for a TI AM indication of 50% modulation.

4.4.5 Depress TI FUNCTION FM switch.

4.4.6 Vary Signal Generator amplitude for 0 to +10 dBm as required for a TI FM deviation null (minimum value). Record the TI display value (FM Deviation).

4.4.7 Subtract the FM Residual value recorded in step 4.2.5 from the value recorded in 4.4.6 to find AM rejection FM peak deviation.

4.4.8 The AM rejection FM peak deviation must be less than 100 Hz Peak.

4.5 AM AUDIO DISTORTION CALIBRATION:

NOTE

Distortion will only be checked at 1 kHz because of available generators.

4.5.1 Perform AM Audio Distortion calibration with equipment connected as in Figure 3.

4.5.2 Set Signal Generator as required for a 30 MHz at 0 dBm, AM to 90% and EXT DC.

4.5.3 Depress the TI switches as follows:

FILTERS	15 kHz (8210) 30 kHz (8210-01)
PEAK	AVG
FUNCTION	AM
RANGE	100

4.5.4 Set Audio Analyzer for a 600 Ω source output (47.0 Special). Set for a output frequency of 1 kHz, and adjust output amplitude for a TI AM indication of 90% modulation.

4.5.5 Verify Audio Analyzer Distortion indication is less than 0.5%.

4.6 AUDIO FREQUENCY RESPONSE 15 kHz CALIBRATION:

4.6.1 Perform the audio frequency response 15 kHz test, with equipment connected as in Figure 3.

4.6.2 Set Signal Generator to 60% AM.

4.6.3 Depress the TI switches as follows:

FILTERS	15 kHz (8210) 30 kHz (8210-01)
PEAK	AVG
FUNCTION	AM
RANGE	100

4.6.4 Set Audio Analyzer for a 600 Ω source output (47.0 Special). Set for a output frequency of 1 kHz, and adjust output amplitude for a TI AM indication of 60% modulation.

4.6.5 While maintaining a constant Audio Analyzer output amplitude, vary the modulation frequency between 50 Hz and 5 kHz for 8210, 50 Hz and 10 kHz for 8210-01.

4.6.6 Verify the TI display indication is within 59.4% and 60.6% at all modulation frequencies.

4.6.7 While maintaining a constant Audio Analyzer output amplitude, vary the modulation frequency between 5 kHz and 7.5 kHz for 8210, 10 kHz and 15 kHz for 8210-01.

4.6.8 Verify the TI display indication is within 58.5% and 61.2% at all modulation frequencies.

4.6.9 While maintaining a constant Audio Analyzer output amplitude, set frequency to 15 kHz for 8210, or 30 kHz for 8210-01.

4.6.10 Verify the TI display indication is within 40.4% and 44.3%.

4.6.11 Set Audio Analyzer and Signal Generator outputs to OFF.

4.6.12 Disconnect equipment shown in Figure 3.

4.7 FM DISTORTION CALIBRATION:

4.7.1 Connect the equipment as shown in Figure 4.

4.7.2 Set Signal Generator as required for a 100 MHz at 0 dBm, FM to 75 kHz deviation and EXT DC.

4.7.3 Depress the TI switches as follows:

FILTERS	15 kHz (8210) 30 kHz (8210-01)
PEAK	AVG
FUNCTION	FM
RANGE	100

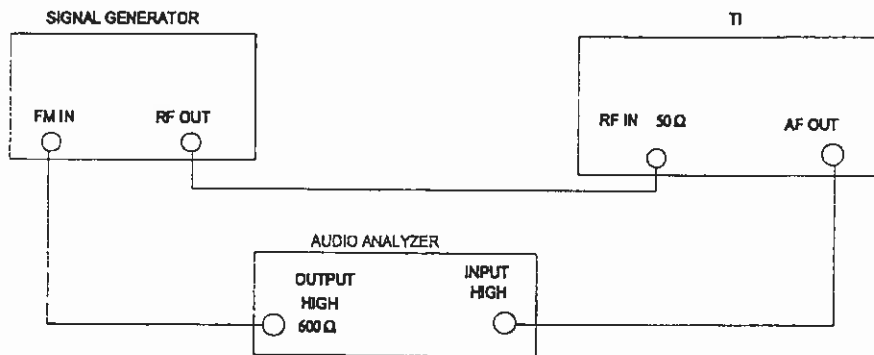

Figure 4.

4.7.4 Set Audio Analyzer for a 600 Ω source output (47.0 Special). Set for a output frequency of 1 kHz, and adjust output amplitude for a TI FM indication of 75 kHz peak deviation.

4.7.5 Verify the distortion is less than 0.25%.

■ 4.7.6 Repeat steps 4.7.2, 4.7.4 and 4.7.5 for modulation frequency of 50 Hz and 10 kHz.

4.8 **FM REJECTION CALIBRATION:**

■ 4.8.1 With equipment connected as shown in Figure 4 perform the FM rejection calibration.

■ 4.8.2 Set Signal Generator as required for a 100 MHz at 0 dBm, FM to 100 kHz deviation.

4.8.3 Depress the TI switches as follows:

FILTERS	15 kHz (8210) 30 kHz (8210-01)
PEAK	AVG
FUNCTION	FM
RANGE	100

4.8.4 Set Audio Analyzer for a 600 Ω source output (47.0 Special). Set for a output frequency of 1 kHz, and adjust output amplitude for a TI FM indication of 100 kHz peak deviation.

4.8.5 Set TI controls as Follows:

FUNCTION	AM
RANGE	10

4.8.6 Verify the TI display indicated a value less than 1.0% peak.

4.9 AUDIO FREQUENCY RESPONSE 3 kHz LOW PASS FILTER CALIBRATION:

4.9.1 With equipment connected as shown in Figure 4 perform the 3 kHz filter calibration.

4.9.2 Depress the TI switches as follows:

FILTERS	3 kHz (8210) 3 kHz (8210-01)
PEAK	AVG
FUNCTION	FM
RANGE	100

4.9.3 Set Audio Analyzer for a 600 Ω source output (47.0 Special). Set for a output frequency of 300 Hz, and adjust output amplitude for a TI FM indication of 100 kHz peak deviation.

4.9.4 While maintaining a constant Audio Analyzer output amplitude, set the modulation frequency to 3.000 kHz.

4.9.5 Verify the TI display indication is within 67.5 to 73.8 kHz.

4.10 AUDIO FREQUENCY RESPONSE 750 μ s DE-EMPHASIS CALIBRATION:

4.10.1 With equipment connected as shown in Figure 4 perform the de-emphasis calibration.

4.10.2 Set Signal Generator as required for a 100 MHz at 0 dBm, FM to 100 kHz deviation and EXT DC.

4.10.3 Depress the TI switches as follows:

FILTERS	3 kHz (8210) 3 kHz (8210-01)
PEAK	AVG
FUNCTION	FM
RANGE	100

4.10.4 Set Audio Analyzer for a 600 Ω source output (47.0 Special). Set for a output frequency of 212.2 Hz, and adjust output amplitude for a TI FM indication of 100 kHz peak deviation.

4.10.5 Depress TI FILTER, DE-EMPHASIS switch.

T.O. 33K3-4-3070-1

4.10.6 Verify the TI display indication is within 68.0 to 73.5 kHz.

4.10.7 Disconnect equipment shown in Figure 4.

4.11 AM MODULATION DEPTH ACCURACY CALIBRATION:

4.11.1 Connect the equipment as shown in Figure 5.

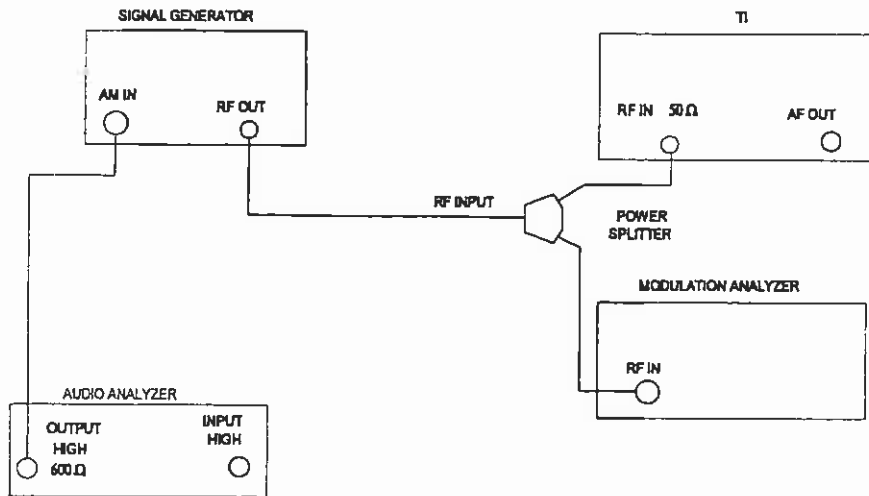

Figure 5.

4.11.2 Set the Signal Generator for a 30 MHz, at +3 dBm, AM to 30% and EXT DC.

4.11.3 Depress the TI switches as follows:

FILTERS	15 kHz (8210) 30 kHz (8210-01)
PEAK	AVG
FUNCTION	AM
RANGE	100

4.11.4 Adjust Audio Analyzer for a output frequency of 1 kHz, and adjust output amplitude for a Modulation Analyzer AM indication of 30% depth.

4.11.5 Verify TI indicates a AM depth 29.7 to 30.3% (See Table 3 Note).

4.11.6 Set Audio Analyzer frequency and Modulation Analyzer Depth (%), as listed in Table 3.

4.11.7 At each Modulation Rate and Depth verify the TI display indicates a depth value within the limits listed in Table 3.

Table 3.

Output	Signal Generator MOD%	Audio Analyzer (Hz)	Modulation Analyzer (%)	T1 Limits (%)
8210				
30 MHz at +3 dBm	30	1 k	30	29.7 to 30.3 *
30 MHz at +3 dBm	50	1 k	50	49.5 to 50.5 *
30 MHz at +3 dBm	70	1 k	70	69.3 to 70.7 *
30 MHz at +3 dBm	90	1 k	90	89.1 to 90.9 *
30 MHz at +3 dBm	90	6 k	90	88.2 to 91.8 *
30 MHz at +3 dBm	90	7.5 k	90	88.2 to 91.8 *
8210-01				
30 MHz at +3 dBm	30	1 k	30	29.7 to 30.3 *
30 MHz at +3 dBm	50	1 k	50	49.5 to 50.5 *
30 MHz at +3 dBm	70	1 k	70	69.3 to 70.7 *
30 MHz at +3 dBm	90	1 k	90	89.1 to 90.9 *
30 MHz at +3 dBm	90	9.9 k	90	89.1 to 90.9 *
30 MHz at +3 dBm	90	10.1 k	90	88.2 to 91.8 *
30 MHz at +3 dBm	90	15 k	90	88.2 to 91.8 *

* Note: Peak residuals must be accounted for to obtain the listed Accuracy.

4.11.8 Set Audio Analyzer and Signal Generator RF Outputs to OFF.

4.11.9 Set all STANDBY/POWER switches to STANDBY or OFF. Disconnect and secure all equipment.

CALIBRATION PERFORMANCE TABLE

4.1 CARRIER LEVEL SENSITIVITY CALIBRATION:

<u>Frequency (MHz)</u>	<u>Limit (mV)</u>
10 to 500	10
500 to 1500	30

CALIBRATION PERFORMANCE TABLE (Cont.)

4.2 FM RESIDUAL AND AM RESIDUAL CALIBRATION:

FM Residual (8210)

<u>Low Pass Filter</u>	<u>Frequency</u>	<u>Bandwidth</u>	<u>Limits</u>
15 kHz	500 MHz	100 kHz	<13.3 mVrms
Specification is <200 Hz rms at 1.5 GHz decreasing linearly to a floor of <15 Hz rms.			
3 kHz	500 MHz	100 kHz	<10.0 mVrms
Specification is <150 Hz rms at 1.5 GHz decreasing linearly to a floor of <5 Hz rms.			

AM Residual (8210)

15 kHz	500 MHz	100 kHz	<50 mVrms
Specification is <0.25% for input level above 100 mV rms.			
3 kHz	500 MHz	100 kHz	<30 mVrms
Specification is <0.15% for input level above 100 mV rms. AM residuals increase linearly with frequency at carrier frequencies above 520 MHz.			

FM Residual (8210-01)

<u>Low Pass Filter</u>	<u>Frequency</u>	<u>Bandwidth</u>	<u>Limits</u>
30 kHz	500 MHz	100 kHz	<26.6 mVrms
Specification is <400 Hz rms at 1.5 GHz decreasing linearly to a floor of <25 Hz rms.			
3 kHz	500 MHz	100 kHz	<10.0 mVrms
Specification is <150 Hz rms at 1.5 GHz decreasing linearly to a floor of <5 Hz rms.			

AM Residual (8210-01)

30 kHz	500 MHz	100 kHz	<70 mVrms
Specification is <0.35% for input level above 100 mV rms.			
3 kHz	500 MHz	100 kHz	<30 mVrms
Specification is <0.15% for input level above 100 mV rms. AM residuals increase linearly with frequency at carrier frequencies above 520 MHz.			

4.3 FM MODULATION DEVIATION ACCURACY CALIBRATION:

<u>Audio Analyzer (Hz)</u>	<u>Signal Generator (Deviation kHz)</u>	<u>TI SCALE</u>	<u>Modulation Analyzer (kHz)</u>	<u>TI Limits (kHz)</u>
8210				
1 k	100	100	100	99.0 to 101.0 *
50	100	100	100	99.0 to 101.0 *

See Footnotes at the end of the Table.

CALIBRATION PERFORMANCE TABLE (Cont.)

4.3 FM MODULATION DEVIATION ACCURACY CALIBRATION:(Cont.)

<u>Audio Analyzer (Hz)</u>	<u>Signal Generator (Deviation kHz)</u>	<u>TI SCALE</u>	<u>Modulation Analyzer (kHz)</u>	<u>TI Limits (kHz)</u>
8210 (Cont.)				
4.9 k	100	100	100	99.0 to 101.0 *
5.1 k	100	100	100	98.0 to 102.0 *
7.5 k	100	100	100	98.0 to 102.0 *
1 k	10	10	10	9.90 to 10.10 *
8210-01				
1 k	100	100	100	99.0 to 101.0 *
50	100	100	100	99.0 to 101.0 *
5.0	100	100	100	99.0 to 101.0 *
7.5 k	100	100	100	99.0 to 101.0 *
9.9 k	100	100	100	99.0 to 101.0 *
10.1 k	100	100	100	98.0 to 102.0 *
15.0 k	100	100	100	98.0 to 102.0 *
1 k	10	10	10	9.90 to 10.1 *

* Peak residuals must be accounted for to obtain the listed Accuracy.

4.4 AM REJECTION CALIBRATION:

<u>AM Modulation Rate</u>	<u>AM Modulation Depth</u>	<u>Limit (Deviation)</u>
1 kHz	50%	<100 Hz Peak

4.5 AM AUDIO DISTORTION CALIBRATION:

<u>RF Frequency 30 MHz 90% depth</u>	<u>Audio Analyzer Mod rate (Hz)</u>	<u>Limits (<%)</u>
	1 kHz	0.5

CALIBRATION PERFORMANCE TABLE (Cont.)

4.6 AUDIO FREQUENCY RESPONSE 15 kHz CALIBRATION:

<u>RF Frequency</u> 30 MHz 60% depth (8210)	<u>Audio Analyzer</u> <u>Mod rate (Hz)</u>	<u>Limits</u> (%)
	50 to 5 kHz	54.9 to 60.6
	5 to 7.5 kHz	58.5 to 61.2
(8210-01)	15.0 kHz	40.4 to 44.3
	50 to 10 kHz	54.9 to 60.6
	10 to 15 kHz	58.5 to 61.2
	30 kHz	40.4 to 44.3

4.7 FM DISTORTION CALIBRATION:

<u>RF Frequency</u> 100 MHz 75 kHz dev	<u>Audio</u> <u>Analyzer (Hz)</u>	<u>Limits</u> (%)
	50	<0.25
	1 k	<0.25
	10 k	<0.25

4.8 FM REJECTION CALIBRATION:

<u>RF Frequency</u> 100 MHz 100 kHz dev	<u>Audio</u> <u>Analyzer (kHz)</u>	<u>Limits</u> (AM%)
	1	<1.0

4.9 AUDIO FREQUENCY RESPONSE 3 kHz LOW PASS FILTER CALIBRATION:

<u>RF Frequency</u> 100 MHz 100 kHz dev	<u>Audio</u> <u>Analyzer (Hz)</u>	<u>Limits</u> (DEV (kHz))
3 kHz Low Pass	300	100
	3000	67.5 to 73.8

4.10 AUDIO FREQUENCY RESPONSE 750 μ s DE-EMPHASIS CALIBRATION:

<u>RF Frequency</u> 100 MHz 100 kHz dev	<u>Audio</u> <u>Analyzer (Hz)</u>	<u>Limits</u> (DEV (kHz))
3 kHz Low Pass	212.2	100
750 μ s De-emphasis	212.2	68.0 to 73.5

CALIBRATION PERFORMANCE TABLE (Cont.)

4.11 AM MODULATION DEPTH ACCURACY CALIBRATION:

<u>Output</u>	<u>Signal Generator</u>	<u>MOD%</u>	<u>Audio Analyzer</u> <u>(Hz)</u>	<u>Modulation</u> <u>Analyzer (%)</u>	<u>TJ Limits</u> <u>(%)</u>
8210					
30 MHz at +3 dBm		30	1 k	30	29.7 to 30.3 *
30 MHz at +3 dBm		50	1 k	50	49.5 to 50.5 *
30 MHz at +3 dBm		70	1 k	70	69.3 to 70.7 *
30 MHz at +3 dBm		90	1 k	90	89.1 to 90.9 *
30 MHz at +3 dBm		90	6 k	90	88.2 to 91.8 *
30 MHz at +3 dBm		90	7.5 k	90	88.2 to 91.8 *
8210-01					
30 MHz at +3 dBm		30	1 k	30	29.7 to 30.3 *
30 MHz at +3 dBm		50	1 k	50	49.5 to 50.5 *
30 MHz at +3 dBm		70	1 k	70	69.3 to 70.7 *
30 MHz at +3 dBm		90	1 k	90	89.1 to 90.9 *
30 MHz at +3 dBm		90	9.9 k	90	89.1 to 90.9 *
30 MHz at +3 dBm		90	10.1 k	90	88.2 to 91.8 *
30 MHz at +3 dBm		90	15 k	90	88.2 to 91.8 *

* Note: Peak residuals must be accounted for to obtain the listed Accuracy.

WARRANTY

Boonton Electronics Corporation warrants its products to the original purchaser to be free from defects in material and workmanship and to operate within applicable specifications for a period of one year from date of shipment, provided they are used under normal operating conditions. This warranty does not apply to active devices that have given normal service, to sealed assemblies which have been opened or to any item which has been repaired or altered without our authorization.

We will repair, or at our option, replace any of our products which are found to be defective under the terms of this warranty.

There will be no charge for parts, labor, or forward and return normal ground transportation during the first three months of this warranty.*

There will be no charge for parts, labor, or return normal ground transportation during the fourth through twelfth month of this warranty.*

Except for such repair or replacement, we will not be liable for any incidental damages or for any consequential damages, as those terms are defined in Section 2-715 of the Uniform Commercial Code, in connection with products covered by this warranty.

*For *overseas shipments*, there will be no charge for Air Freight during these specified time periods.

BOONTON

BOONTON ELECTRONICS CORPORATION ■ 791 ROUTE 10 ■ RANDOLPH, NEW JERSEY 07869
TELEPHONE: (201) 584-1077 ■ TLX: 710-986-8215 BOONTRONICS

9/1/83

BOONTON

BOONTON ELECTRONICS CORPORATION