

Instruction Manual  
**Model 72B**  
Capacitance Meter

**BOONTON**

BOONTON ELECTRONICS CORPORATION ■ 791 ROUTE 10 ■ RANDOLPH, NEW JERSEY 07869  
TELEPHONE: (201) 584-1077 ■ TLX: 710-986-8215 BOONTRONICS

## SAFETY SUMMARY

The following general safety precautions must be observed during all phases of operation and maintenance of this instrument. Failure to comply with these precautions or with specific warnings elsewhere in this manual violates safety standards of design, manufacture, and intended use of the instrument. Boonton Electronics assumes no liability for the customer's failure to comply with these requirements.

### THE INSTRUMENT MUST BE GROUNDED.

To minimize shock hazard the instrument chassis and cabinet must be connected to an electrical ground. The instrument is equipped with a three conductor, three prong a.c. power cable. The power cable must either be plugged into an approved three-contact electrical outlet or used with a three-contact to a two-contact adapter with the (green) grounding wire firmly connected to an electrical ground at the power outlet.

### DO NOT OPERATE THE INSTRUMENT IN AN EXPLOSIVE ATMOSPHERE.

Do not operate the instrument in the presence of flammable gases or fumes.

### KEEP AWAY FROM LIVE CIRCUITS.

Operating personnel must not remove instrument covers. Component replacement and internal adjustments must be made by qualified maintenance personnel. Do not replace components with the power cable connected. Under certain conditions dangerous voltages may exist even though the power cable was removed, therefore; always disconnect power and discharge circuits before touching them.

### DO NOT SERVICE OR ADJUST ALONE.

Do not attempt internal service or adjustment unless another person, capable of rendering first aid and resuscitation, is present.

### DO NOT SUBSTITUTE PARTS OR MODIFY INSTRUMENT.

Do not install substitute parts or perform any unauthorized modification of the instrument. Return the instrument to Boonton Electronics for repair to ensure that the safety features are maintained.

### SAFETY SYMBOLS.



This safety requirement symbol (located on the rear panel) has been adopted by the International Electrotechnical Commission, Document 66 (Central Office) 3, Paragraph 5.3, which directs that an instrument be so labeled if, for the correct use of the instrument, it is necessary to refer to the instruction manual. In this case it is recommended that reference be made to the instruction manual when connecting the instrument to the proper power source. Verify that the correct fuse is installed for the power available, and that the switch on the rear panel is set to the applicable operating voltage.

**CAUTION**

The CAUTION sign denotes a hazard. It calls attention to an operation procedure, practice, or the like, which, if not correctly performed or adhered to, could result in damage to or destruction of part or all of the equipment. Do not proceed beyond a CAUTION sign until the indicated conditions are fully understood and met.

**WARNING**

The WARNING sign denotes a hazard. It calls attention to an operation procedure, practice, or the like, which, if not correctly performed or adhered to, could result in injury or loss of life. Do not proceed beyond a WARNING sign until the indicated conditions are fully understood and met.



Indicates dangerous voltages.

# SECTION I

## GENERAL INFORMATION

### 1-1. INTRODUCTION

This instruction manual provides general information, installation and operating instructions, theory of operations, maintenance instructions, a parts lists, and schematics for the Model 72B.

### SAFETY NOTICE

Although this instrument has been designed in accordance with international safety standards, general safety precautions must be observed during all phases of operation and maintenance of the instrument. Failure to comply with the precautions listed in the Safety Summary located in the front of this manual could result in serious injury or death. Service and adjustment should be performed only by qualified service personnel.

### 1-2. DESCRIPTION

The Model 72B Capacitance Meter provides instant, direct reading, three-terminal and differential capacitance measurements from 0.01 to 3000 pF. This coverage is divided into eight ranges, selected either by the front-panel switch or remotely, arranged in a 1 - 3 - 10 sequence. The solid-state design and crystal-controlled signal source contribute to the high stability and excellent reliability of the instrument.

The 1 MHz test signal is held to a level of 15 mV, r.m.s. (option -03 is 100 mV), allowing the measurement of capacitance of semiconductor devices. The provision for application of d.c. bias to either or both sides of the specimen makes it possible to measure these devices under normal operating conditions. The bias voltages can be applied either to the rear-panel terminals provided, or to the appropriate pins on the edge connector.

The 72B employs an unusual range-switching system using switching diodes and miniature reed relays; the elimination of the switch contacts from the measurement circuits assures a maximum of reliability and stability.

The instrument's phase-sensitive detector system permits the measurement of even low-Q devices (down to Q=1) without appreciably degrading the accuracy of the measurement. The 72B responds to the effective parallel capacitance of the test specimen. For a specimen with predominantly series loss and a Q-factor of less than 10, the 72B will indicate the effective parallel capacitance; i.e.:

$$C_p = C_s Q^2 / (1 + Q^2)$$

Two plug-in connection adapters are supplied with the 72B. One adapter, fitted with two sets of coaxial connectors, 72-4B, is intended for use with coaxial cables and remotely located test fixtures for both three-terminal and differential measurements. The second adapter, 72-5C, with three terminal posts, is used for wire-lead components; differential measurements are not possible with this adapter.

A linear d.c. output is available at rear-panel terminals as well as at the appropriate pins on the edge connector. This feature extends the range of applications beyond ordinary laboratory measurements to include production testing as well as a variety of control functions. Flexibility is further

§1-2, Continued.

enhanced by the provision of remote ranging terminals.

Remote ranging is controlled by grounding the MANUAL DISABLE terminal on the rear edge connector, disabling the front-panel range switch. Grounding any one of the eight range-line terminals will then select that range.

Connection to the rear-panel edge connector should be made with an Amphenol Type 225-22221-101 jack.

### 1-3. ACCESSORIES FURNISHED

A. Test Post Adapter (BNC), 72-4B: for remote connections to TEST and DIFF terminals.

B. Test Post Adapter (Clips), 72-5C: grip-posts for local connection of axial-lead components.

### 1-4. OPTIONS AND ACCESSORIES

#### A. Options

1. -03: 100 mV r.m.s. test signal (standard is 15 mV, r.m.s.)
2. -05A: 50  $\mu$ s d.c. output response time for full accuracy (standard unit responds in 1 ms). R.M.S. noise level 10 mV (100 kHz bandwidth).

#### B. Accessories

1. 950032: Single rack-mounting kit (mounts left or right).
2. 950030: Dual rack-mounting kit.
3. 76-2A/(1): Capacitance Standard, 0.1 pF.
4. 76-2A/(3): Capacitance Standard, 0.3 pF.
5. 76-2A/(10): Capacitance Standard, 1.0 pF.
6. 76-2A/(13): Capacitance Standard, 3.0 pF.
7. 76-2A/(20): Capacitance Standard, 10.0 pF.
8. 76-2A/(23): Capacitance Standard, 30.0 pF.
9. 76-2A/(30): Capacitance Standard, 100.0 pF.
10. 76-2A/(33): Capacitance Standard, 300.0 pF.
11. 76-2A/(40): Capacitance Standard, 1000.0 pF.
12. 76-2A/(43): Capacitance Standard, 3000.0 pF.
13. 76-3A: Capacitance Decade Standard, 1 MHz: 1 - 3000 pF,  
in a 1-2-3 sequence
14. 953000: Chip Capacitor Test Fixture.

### 1-5. ENVIRONMENTAL DATA, OPERATING AND STORAGE

Temperature: Operating, +10°C to +40°C  
(Refer to Temperature Influence specifications)  
Storage, -55°C to +75°C

1-2

1-6. SPECIFICATIONS

CAPACITANCE RANGE	0.01 to 3000 pF	
FULL-SCALE RANGES	1, 3, 10, 30, 100, 300, 1000, 3000 pF	
ACCURACY		
Q > 5	1 pF f.s.	±(0.5% of reading + 0.01 pF)
	3-1000 pF	±(0.5% of reading + 0.5% f.s.)
	3000 pF	±(1% of reading + 0.5% f.s.)
Q = 1 to 5	1 pF f.s.	±(1% of reading + 0.01 pF)
	3-1000 pF	±(1% of reading + 0.5% f.s.)
	3000 pF	±(2% of reading + 0.5% f.s.)
RESOLUTION	0.5% of f.s. on all ranges	
METER	4-1/2" taut-band. Two linear scales: 0 to 10 (0.1 per division), and 0 to 30 (0.5 per div.).	
Linearity	1-3000 pF f.s.	±(0.1% of reading ±0.01% f.s.)
	1000-3000 pF	±(0.25% of reading ±0.01% f.s.)
Response Time	1 ms (for full accuracy) 50 μs (for full accuracy) Option-05A	
Source Resistance	1 kΩ	
EXTERNAL BIAS	HI TO GND: ±200 V, maximum LO TO GND: ±400 V, maximum LO to HI: ±600 V, max. (floating supply only)	
TEST SIGNAL	1 MHz, crystal-controlled, 15 mV r.m.s. 100 mV r.m.s. Option -03	
TEMPERATURE INFLUENCE	<u>Temperature Range</u>	<u>Max. Influence</u>
	Reference: 21°C to 25°C	0
	Normal: 18°C to 30°C	0.2% of reading
	Extreme: 10°C to 40°C	0.5% of reading
POWER REQUIREMENTS	100, 120, 220 or 240 V ±10%, 50 to 400 Hz, 7 W	
DIMENSIONS	132 mm high × 211 wide × 305 deep (5.2 in. × 8.3 × 12) without feet	
WEIGHT	3.3 kg (7.2 lbs.), approximately	

1  
2  
3  
4  
5  
6  
7  
8  
9  
10  
11  
12  
13  
14  
15  
16  
17  
18  
19  
20  
21  
22  
23  
24  
25  
26  
27  
28  
29  
30  
31  
32  
33  
34  
35  
36  
37  
38  
39  
40  
41  
42  
43  
44  
45  
46  
47  
48  
49  
50  
51  
52  
53  
54  
55  
56  
57  
58  
59  
60  
61  
62  
63  
64  
65  
66  
67  
68  
69  
70  
71  
72  
73  
74  
75  
76  
77  
78  
79  
80  
81  
82  
83  
84  
85  
86  
87  
88  
89  
90  
91  
92  
93  
94  
95  
96  
97  
98  
99  
100

## SECTION II

### INSTALLATION & OPERATION

#### 2-1. INSTALLATION

Each instrument has been inspected and tested at the factory for full compliance with all specifications before packing. Notify the carrier and the factory immediately should any indication of shipping damage be apparent upon unpacking. It is recommended that the special packing materials be saved for use in the event that the instrument must be reshipped.

#### 2-2. OPERATING CONTROLS, INDICATORS AND CONNECTORS

All controls, indicators and connectors used during operation of the 72B are described in Table 2-1, below.

Table 2-1. Operating Controls, Indicators and Connectors

ITEM	FUNCTION
FULL SCALE pF switch	Selects full-scale range of instrument.
PWR switch	Turns line power on and off. LED is lit when power is "on".
ZERO control	Used to balance out capacitance across TEST terminals contributed by exposed terminations of connecting cables, test fixtures, etc.
METER	Indicates capacitance with two linear scales, reading 0 to 10 with 0.1 per division, and 0 to 30 with 0.5 per division.
ANALOG OUTPUT terminals	Provide a d.c. voltage proportional to the meter reading, adjustable $\pm 2\%$ .
BIAS terminals	External d.c. bias may be applied to the HI and LO Test Terminals via these posts.
LINE VOLTAGE switch	Permits selection of appropriate a.c. line voltage.
Fuse holder	Contains replaceable line fuse.
P102	A 22-pin edge connector for remote ranging and output connections. See Figure 4-4.
Test adapter	These banana plugs are used for storing the unused connection adapter: 72-4B or 72-5C.
	This safety-requirement symbol has been adopted by the International Electrotechnical Commission, Document 66 (Central Office) 3, ¶5.3, which directs that an instrument be so labeled, if, for the correct use of the instrument, it is necessary to refer to the Instruction Manual. In this case it is recommended that reference be made to the Instruction Manual when connecting the instrument to the proper power source.

### 2-3. OPERATING INSTRUCTIONS

A. See that the rear-panel voltage selector switch is set correctly for the line voltage used. Check also that the proper line fuse is installed: a 0.10-A fuse for 100 or 120 V; 0.06-A fuse for 220 or 240 V. If necessary, adjust the mechanical-zero screw of the meter. Plug the instrument into a power outlet and allow it to warm up for a few minutes.

B. Plug the appropriate test connection adapter into the front-panel receptacle. If remote or other coaxially connected components are to be measured, connect all cables and test fixtures to the TEST jacks of the connection adapter. The test adapter is held in place by a captive screw located in the center of the adapter.

C. Switch the instrument to its lowest range (1 pF, f.s.). Set the meter reading to zero, using the ZERO control.

NOTE: The ZERO control uses a dual-ratio vernier to drive a differential air capacitor having a full 360° of rotation. The ZERO control turns easily for about 270°, at which point the ratio shifts from 36:1 to 6:1 and the required torque increases abruptly.

The ZERO adjustment has sufficient range to compensate for approximately 5 pF of shunt capacitance across the TEST terminals. If this range is insufficient, a small capacitor (value determined experimentally), can be connected across the DIFF terminals to effect a zero setting within the range of the ZERO control.

D. The instrument is now ready for use. Once the zero setting has been made on the lowest range, it will hold on all other ranges.

### 2-4. REMOTE MEASUREMENTS

A. Cable Shunt Capacitance. When more than a few inches of coaxial cable is used to connect the instrument to a remote fixture, attention must be given to the shunt capacitance of the cable. To maintain the specified accuracy, the values shown in Table 2-2 should not be exceeded.

Table 2-2. Maximum Cable Shunt Capacitance

a. HI post to ground:		
	RANGE	MAX. C
	1 pF & 3 pF	200 pF
	10 to 3000 pF	500 pF
b. LO post to ground: 500 pF, maximum, on all ranges		

*1000 pF to 2100  
Relay B4  
IN - SH  
to ground*

B. Transmission-Line Effect. The remote measurement of capacitance via coaxial cables introduces a measurement error owing to the transmission-line effect on the test voltage transmitted from the LO terminal, and on the received current at the HI terminal. The combined effect is such that the ratio of measured capacitance to actual capacitance is

$$C_m/C = \frac{1 + j\omega Cr}{[\cos \beta l - \omega C Z_0 (\sin \beta l)]^2 [1 + j \frac{\omega Cr (\cos \beta l) + (\sin \beta l)r/Z_0}{\cos \beta l - \omega C Z_0 (\sin \beta l)}]}$$

where  $\beta l$  = the electrical length of each line, in degrees;  
 $Z_0$  = the characteristic impedance of the line, in ohms;  
 (NOTE: At 1 MHz,  $Z_0$  for RG-58/U is approximately 56.5 ohms and relative velocity is 63.5%)  
 and  $r$  = the equivalent resistance of the Capacitance Meter from HI terminal to ground--as shown in the following table.



Range	r
1 pF and 3 pF	140 ohms
10 pF and 30 pF	7 ohms
100 pF and above	1 ohm

For the 72B Capacitance Meter, the error is positive and its magnitude is shown in Figure 2-1 as a function of the measured capacitance,  $C_m$ , and the cable length,  $l$ .

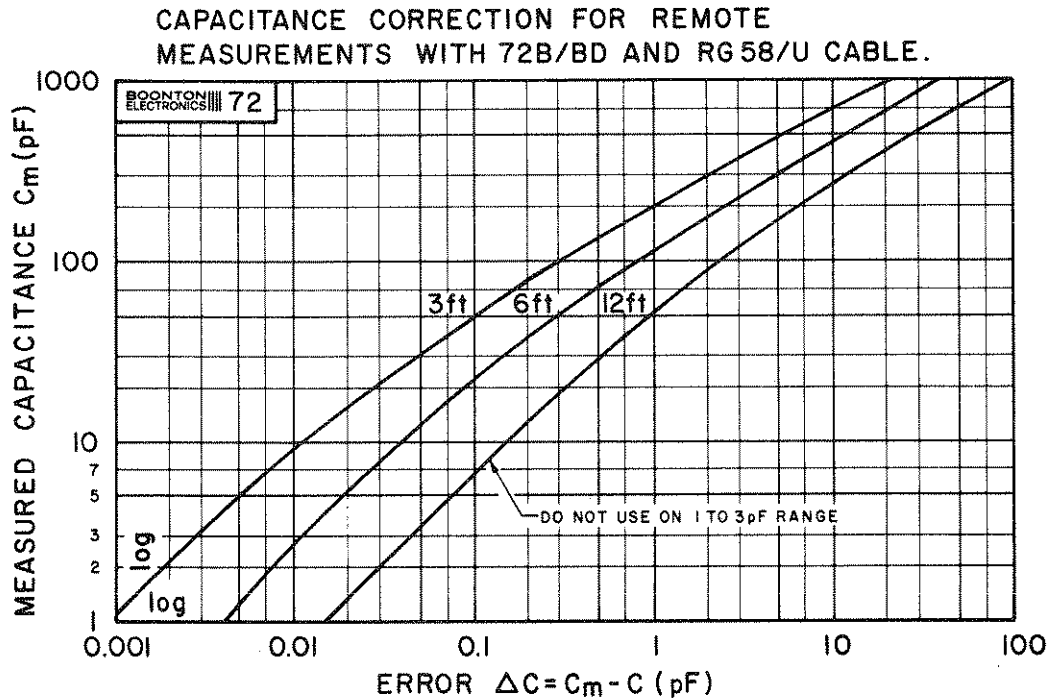

Figure 2-1. Capacitance Correction for Remote Measurements with RG-58/U

The error is not shown for the lower two ranges using 12-foot lengths of cable, as the capacitive loading of the HI test terminal is excessive for lengths of RG-58/U greater than about 3.5 feet, and lengths of about eight feet for the 10 pF and the 30 pF ranges.

When calculating  $\beta l$ , which is the electrical length in degrees of each of the two cables, it is necessary to know the velocity of propagation of the cable at 1 MHz. Tested samples of RG-58/U indicate a relative velocity of 63.5%. The impedance of the same cable measured 57.5 ohms at 1 MHz.

In order for the above correction curves and equation to be valid, it is imperative that the shields of both ends of the coaxial cables be tied together with a strap of low resistance and low inductance.

For short lengths of cable, a reasonable correction may be made based upon the effect of the series inductance of both lengths of cable. The measured capacitance,  $C_m$ , of a specimen will differ from the true capacitance,  $C_t$ ; the error will be seen as an apparent increase in capacitance as follows:

$$C_m = \frac{C_t}{1 - \omega^2 LC_t} = \frac{C_t}{1 - (X_L/X_{C_t})}$$

Or, if the true capacitance is required:

$$C_t = \frac{C_m}{1 + \omega^2 LC_m} = \frac{C_m}{1 + (X_L/X_{C_m})}$$

Where L = the combined series inductance of BOTH lengths of the con-

§2-4B, Continued.

necting cables and the inductance of the sample (generally small with respect to the cables' inductance).

As an approximation, the inductance/foot of RG-58/U cable (with shields common at both ends), is about 0.091  $\mu\text{H}$ .

### 2-5. DIFFERENTIAL TERMINALS

Measurement of the relative differential capacitance between two specimen capacitors can be made by connecting one capacitor to the DIFF terminals, and the other to the TEST terminals. (The capacitance that is connected to the DIFF terminals may be as large as the full-scale value of the selected range, without introducing serious error.) The display will indicate the difference in capacitance between the two; by switching down to the next lower range (but no lower), the resolution will be improved.

Although the 72B is not calibrated for absolute differential measurements, the relative differential can be of value. For example: in determining the change of capacitance of a specimen during heat cycling, the absolute difference between the specimen and a capacitor held at a fixed temperature is not as important as the percentage change between them.

In addition to permitting differential measurements, the DIFF terminals serve another purpose: excess fixture capacitance across the TEST terminals (i.e.: capacitance beyond the normal range of the ZERO control), can be balanced out by the addition of a capacitor to the DIFF terminals (§2-3C).

### 2-6. D.C. BIAS

D.c. bias voltages may be applied to either or both sides of the specimen via the rear-panel bias terminals or via the proper pins on the rear edge connector. The applied voltages should not exceed  $\pm 200$  volts from the HI terminal to ground, or  $\pm 400$  volts from the LO terminal to ground. When bias is applied to one side only, it is recommended that the other bias terminal be connected to ground.

The sum of the two voltages (600 V, d.c.) may be applied between the HI and the LO terminals. In this connection the bias supply should not be grounded (An internal voltage divider, of resistance values of 240  $\text{k}\Omega$  from HI to ground and 510  $\text{k}\Omega$  from LO to ground, establishes the ground point.) The bias lines are internally protected by 30 mA fuses.

2-7. PULSE BIAS (For specific applications contact the Application Engineering Department, Boonton Electronics.) The internal bias circuit of the 72B needs adequate bypassing of the 1 MHz test signal and therefore may be unsuitable for the application of pulses to bias the test specimen through the rear bias terminals.

In any event, pulse bias can be applied through external circuitry (Figure 2-2). If the impedance of the pulse-transformer secondary is small, relative to  $R_1$ , the test specimen may be considered to be in series with a

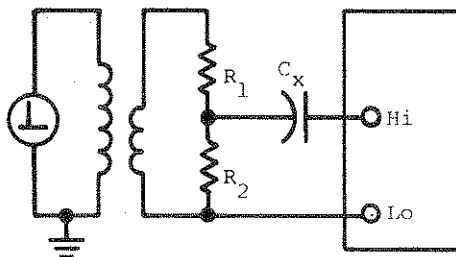

Figure 2-2. Application of Pulse Bias

§2-7, Continued.

resistance of  $R_1 R_2 / (R_1 + R_2)$  ohms. This value need only be less than about one-fifth of the reactance of the test capacitor, at 1 MHz, in order to be ignored by the phase detector in the capacitance meter. The ratio of the two resistors, and their absolute values, will depend upon the pulse transformer and its load-matching requirements, as well as the nature and the magnitude of the pulse needed for bias.

#### 2-8. DC OUTPUT RESPONSE TIME

The rise time of the analog output can be reduced by removing the bypass circuitry in this section of the instrument. The cost of this improvement is an increase in the residual noise at the output terminals.

The normal rise time is  $< 1$  ms and the r.m.s. noise is  $< 1$  mV. If C131 is removed, the rise time will be reduced to  $< 175$   $\mu$ s and the noise will be less than 3 mV. (Option -05A)

#### 2-9. APPLICATIONS

The Model 72B can be used to measure the small-signal capacitance and the forward-gain parameters of bipolar and unipolar transistors at 1 MHz. Capacitance and transconductance are measured with a test signal of 15 mV; beta is measured with a base signal current of approximately 100 nA. (Model 72B-03, the 100 mV test-signal-level option, is not recommended for these measurements.)

The principle of operation of the 72B is basically that of a transmission test set. That is, the test capacitance is interposed between a low-level signal generator of fixed, known, amplitude and phase, and a calibrated phase-sensitive detector. Likewise, the forward-gain parameters of transistors can be measured, provided that the phase of the output current is proper, or is suitably altered. The necessary external circuitry and components are described in the following text. The parameters that can be measured include the following:

##### A. Capacitance (Three Terminal). See Figures 2-3 and 2-4.

NOTE: When measuring the capacitance of transistors, it is imperative to remember that a signal applied to the input of the test device will appear amplified in some form at the output (and usually with a phase reversal). Capacitance measurements must be made with the output of the device connected to the low test terminal (generator), and the device's input connected to the high test terminal (detector).

1.  $C_{rss}$ : Reverse transfer capacitance between drain and gate, source guarded. Device under test is fully biased.  $V_{GS} = 0$ .
2.  $C_{eb}$ : Emitter-to-base capacitance, collector guarded; emitter is reverse biased.  $V_{CE} = 0$  (open circuit for d.c.).
3.  $C_{ce}$ : Collector-to-emitter capacitance, base guarded; collector is reverse biased.  $V_{BE} = 0$  (open circuit for d.c.).
4.  $C_{re}$ : Collector-to-base capacitance, emitter guarded. Device under test is fully biased.
5.  $C_{cb}$ : Collector-to-base capacitance, emitter guarded; collector is reverse biased.  $I_E = 0$  (open circuit for d.c.).

##### B. Capacitance (Two Terminal). See Figure 2-5.

1.  $C_{oss}$ : Output capacitance between drain and source, gate a.c. connected to the source. Device under test is fully biased.  $V_{GS} = 0$ .
2.  $C_{iss}$ : Input capacitance between gate and source with drain a.c. connected to the source. Device under test is fully biased.  $V_{GS} = 0$ .
3.  $C_{ob}$ : Collector-to-base capacitance. Emitter is open-circuited for both a.c. and d.c. Collector is reverse biased.

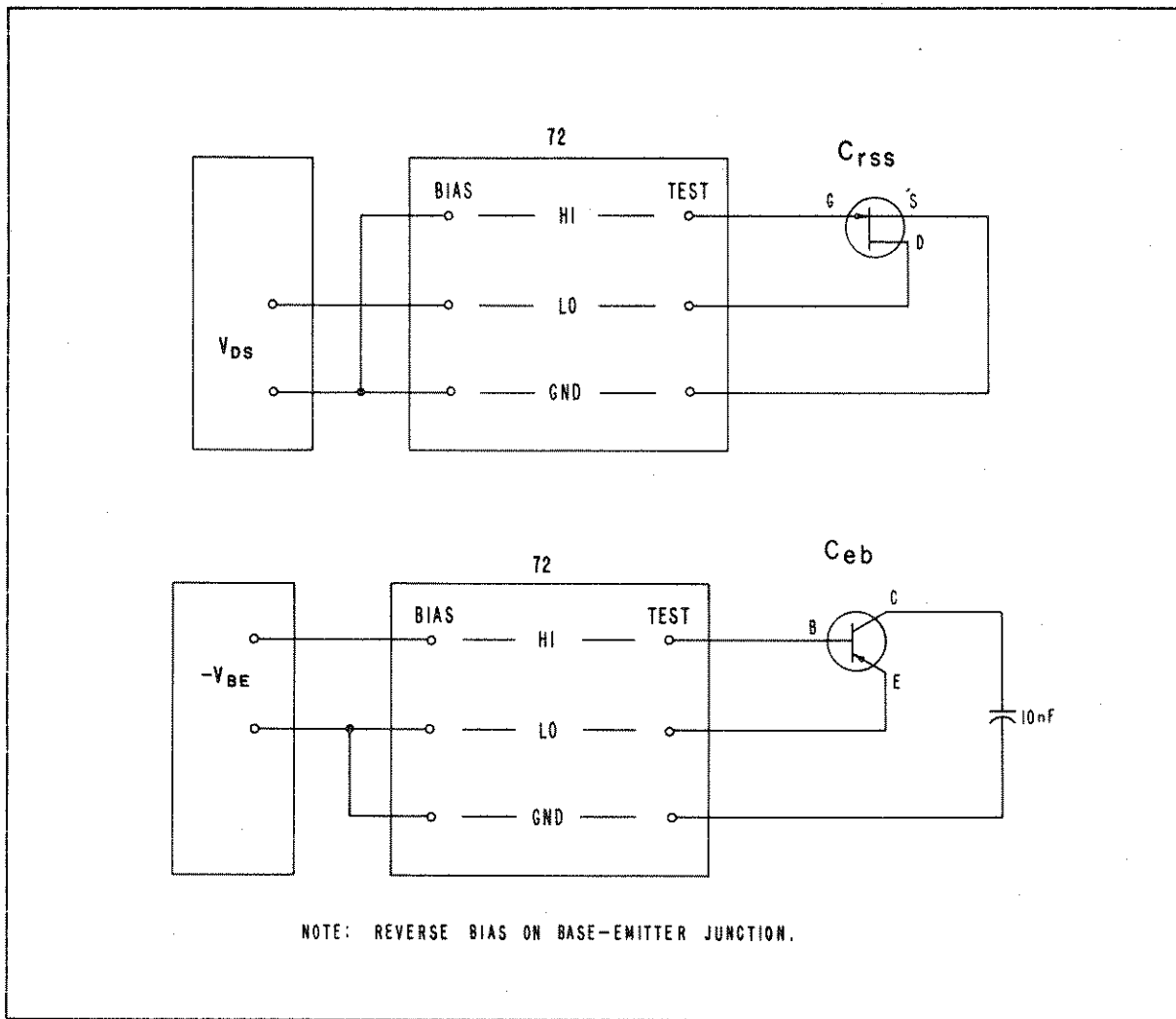

Figure 2-3. Transistor Capacitance Measurements:  $C_{rss}$  and  $C_{eb}$

C. Beta ( $h_{fe}$ ). See Figure 2-6.

A sensibly constant base current,  $i_b$ , of 94 nA can be generated with the aid of a 1.0 pF capacitor connected between the 72B's LO DIFF terminal and the base of the transistor under test. The collector current, which equals  $\beta i_b$ , is fed to the HI TEST terminal, and the instrument responds as though a capacitance of  $\beta \times 1.0$  pF were connected to its terminals. Beta ( $h_{fe}$ ) is equal to the indicated capacitance in picofarads.

The LO DIFF terminal is used for the current source in order to offset the 180° phase reversal of current in the transistor.

The measurement of beta should be made under full bias conditions. In this arrangement, the base current is independent (very nearly) of the input resistance of the transistor because of the quadrature relation between the reactance of the current source and the input resistance

The variable series capacitor in the base circuit (see Figure 2-6) must be adjusted for a value of 1.0 pF. This is easily accomplished by connecting a small jumper between the socket's base and collector terminals (a "unity-gain transistor"), permitting the direct measurement of this capacitance.

If the LO DIFF terminal is used, the reading should be adjusted to -1.0 pF, using the d.c. recorder output; or the LO TEST terminal may be temporarily used for a reading of +1.0 pF on the meter.

§2-9C, Continued.

If the transistor socket (and its circuitry) has excessive capacitance from the base terminal to ground, it can be absorbed with a simple parallel-resonant circuit, using a high L/C ratio to obtain maximum impedance.

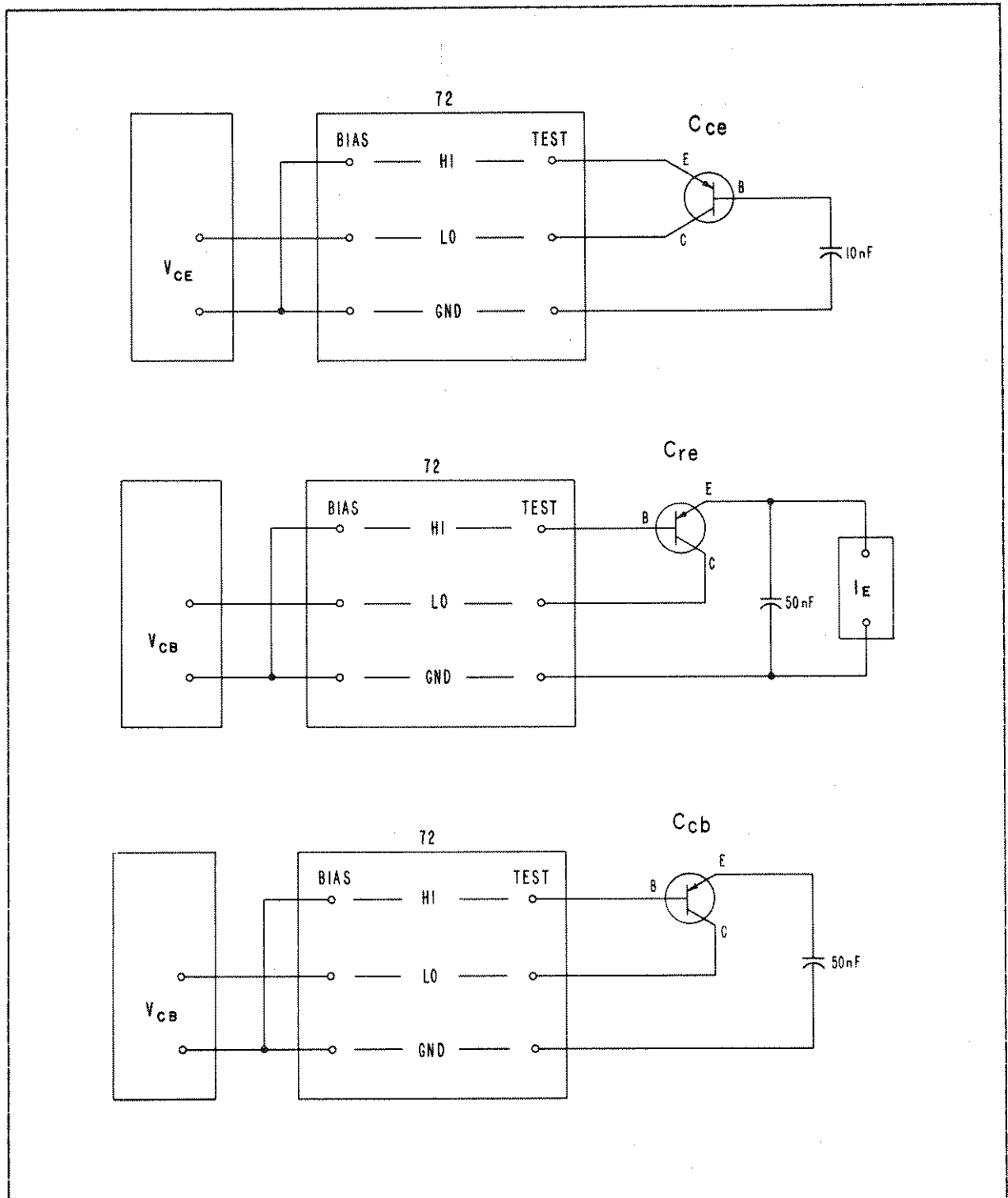

Figure 2-4. Transistor Capacitance Measurements:  $C_{ce}$ ,  $C_{re}$  and  $C_{cb}$

D. Forward Transconductance ( $g_{fs}$ ). See Figure 2-7. The 72B is calibrated for an input current of  $+je_g\omega C$ , where C is the full-scale value of capacitance for any given range. Connecting the gate of a unipolar transistor to the LO TEST terminal will, by definition, generate a drain current of  $eg_{fs}$ , provided that the external drain-circuit impedance

§2-9D, Continued.

is small. Unfortunately, the phase of the drain current lacks the required +90 degrees. A network is needed that presents a low impedance to the drain, and that provides the necessary phase shift of +90 degrees. The circuit shown in Figure 2-5 satisfies these conditions. The resistor, R, is the calibrating resistor for the full-scale value of  $g_{fs}$ . Its value is readily derived. The instrument is calibrated for a high-terminal current of:  $i_c = e_g \omega C / 90^\circ$

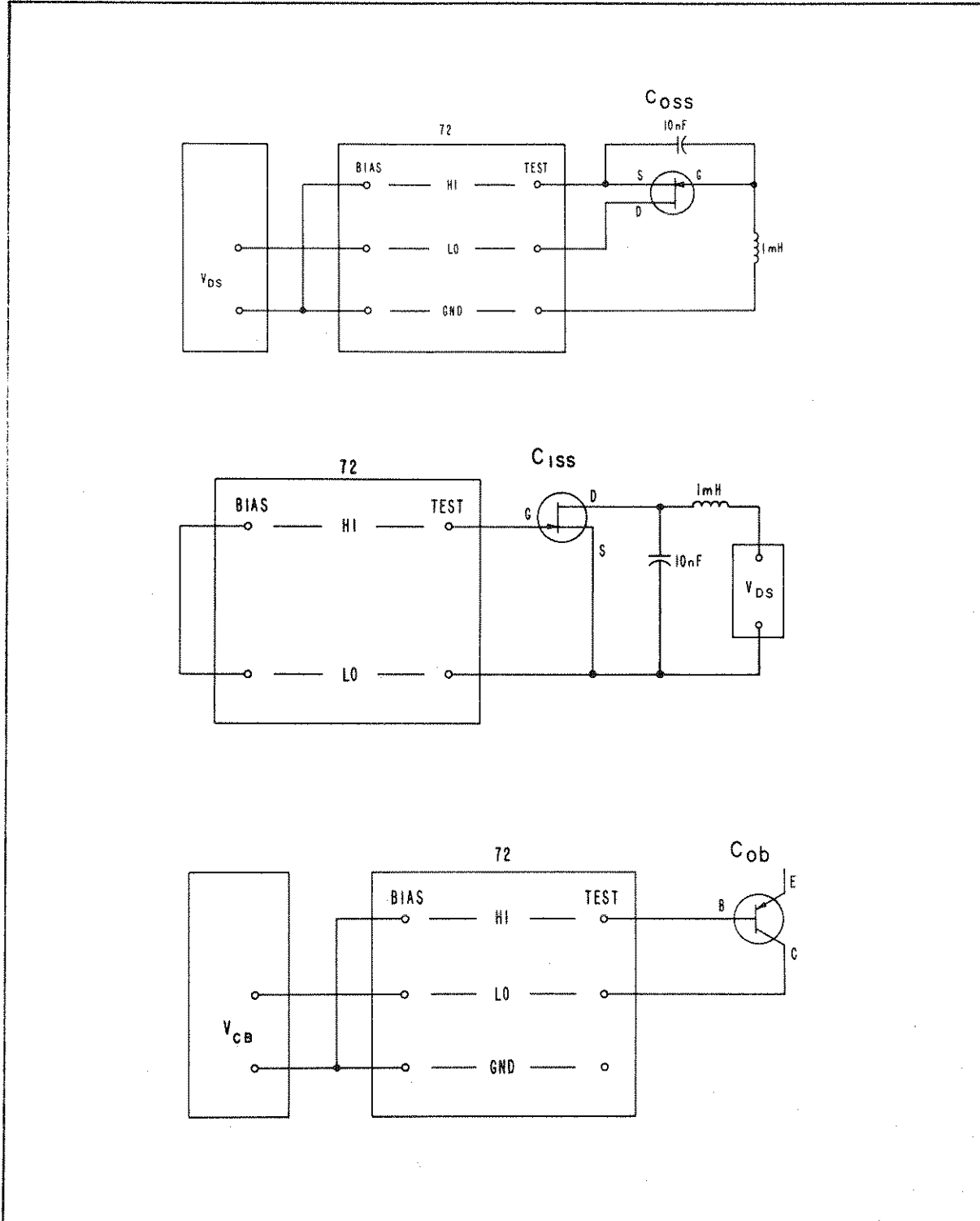

Figure 2-5. Transistor Capacitance Measurements: C<sub>oss</sub>, C<sub>iss</sub> and C<sub>ob</sub>

§2-9D, Continued.

The actual drain current is:

$$i_d = e_g g_{fs}$$

The voltage induced in the secondary of the transformer is:

$$e' = j i_d \omega M / 90^\circ \text{ (polarity arranged for +M)}$$

To achieve a full-scale indication for a given value of  $g_{fs}$  the resistor, R, must have the value:

$$R = e' / i_c = \frac{e_g g_{fs} \omega M / 90^\circ}{e_g \omega C / 90^\circ} = g_{fs} M / C$$

where  $R \gg \omega L_s$  for the current to have the correct phase; M is the mutual inductance of the transformer and equals

$$M = k \sqrt{L_p L_s}$$

The coefficient of coupling, k, may be determined easily by measuring the primary inductance with the secondary open-circuited, then short circuited:

$$k = \sqrt{1 - (L_{sc} / L_{oc})}$$

If the resistor is selected for a full-scale reading of 1000  $\mu S$  on the 100 pF range, the instrument will read:

<u>C Range</u>	<u><math>g_{fs}</math> Range</u>
100 pF	1000 $\mu S$
300 pF	3000 $\mu S$
1000 pF	10,000 $\mu S$
3000 pF	30,000 $\mu S$

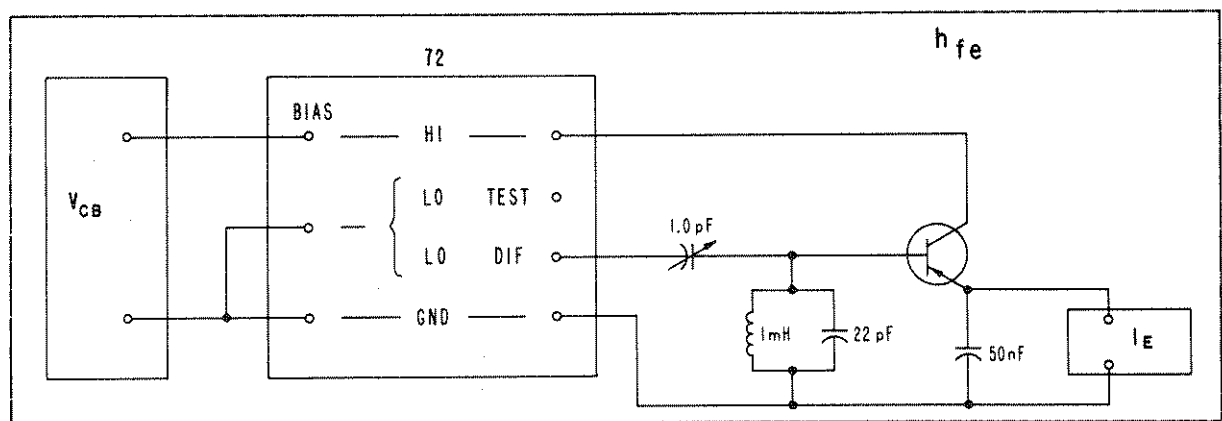

Figure 2-6. Transistor Beta Measurement

§2-9D, Continued.

A typical toroidal transformer might have the following circuit values:

$$\begin{aligned}L_p &= 250 \mu\text{H} \\L_s &= 5 \mu\text{H} \\k &= 0.935\end{aligned}$$

from which,

$$M = 33 \mu\text{H}$$

The series primary capacitance for resonance must equal 100 pF (approx.), and for a full-scale range of 1000  $\mu\text{S}$  on the 100 pF range, the calibrating resistor should equal:

$$R = (1000)(33/100) = 330 \Omega$$

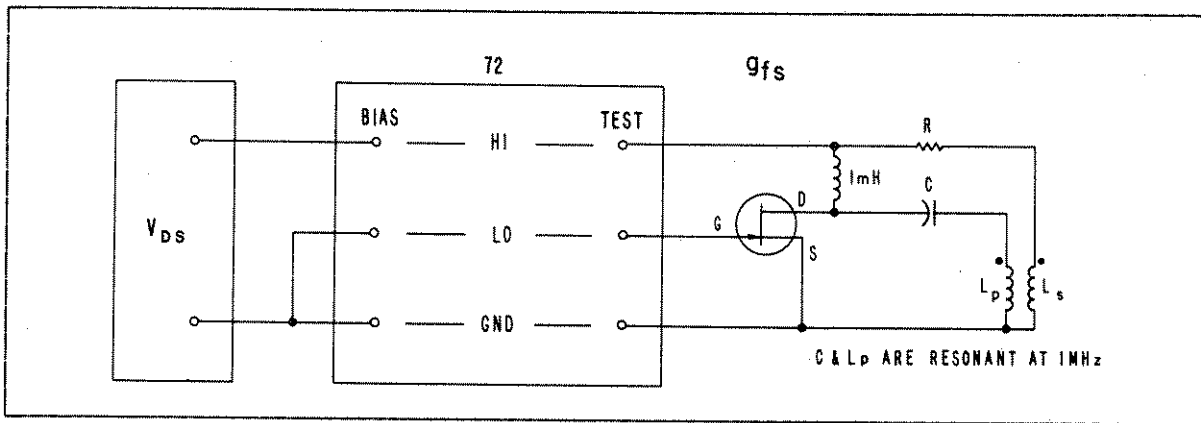

Figure 2-7. Transistor Transconductance Measurement



## SECTION III

### THEORY OF OPERATION

#### 3-1. GENERAL NOTE

Refer to Figure 3-1, a simplified schematic diagram of the Model 72B, in connection with this explanation of the instrument's operation.

#### 3-2. BRIDGE CIRCUITS

The output of the 1 MHz crystal-controlled oscillator appears across the secondary of the transformer, the center tap of which is at r.f. ground. One end of this secondary winding goes to the LO TEST terminal; the other end goes to the LO DIFF terminal. The HI terminals are connected together and lead to the measuring section. A differential capacitor (the ZERO control), has its stators connected across the transformer secondary winding, and its rotor connected to the common HI post connection.

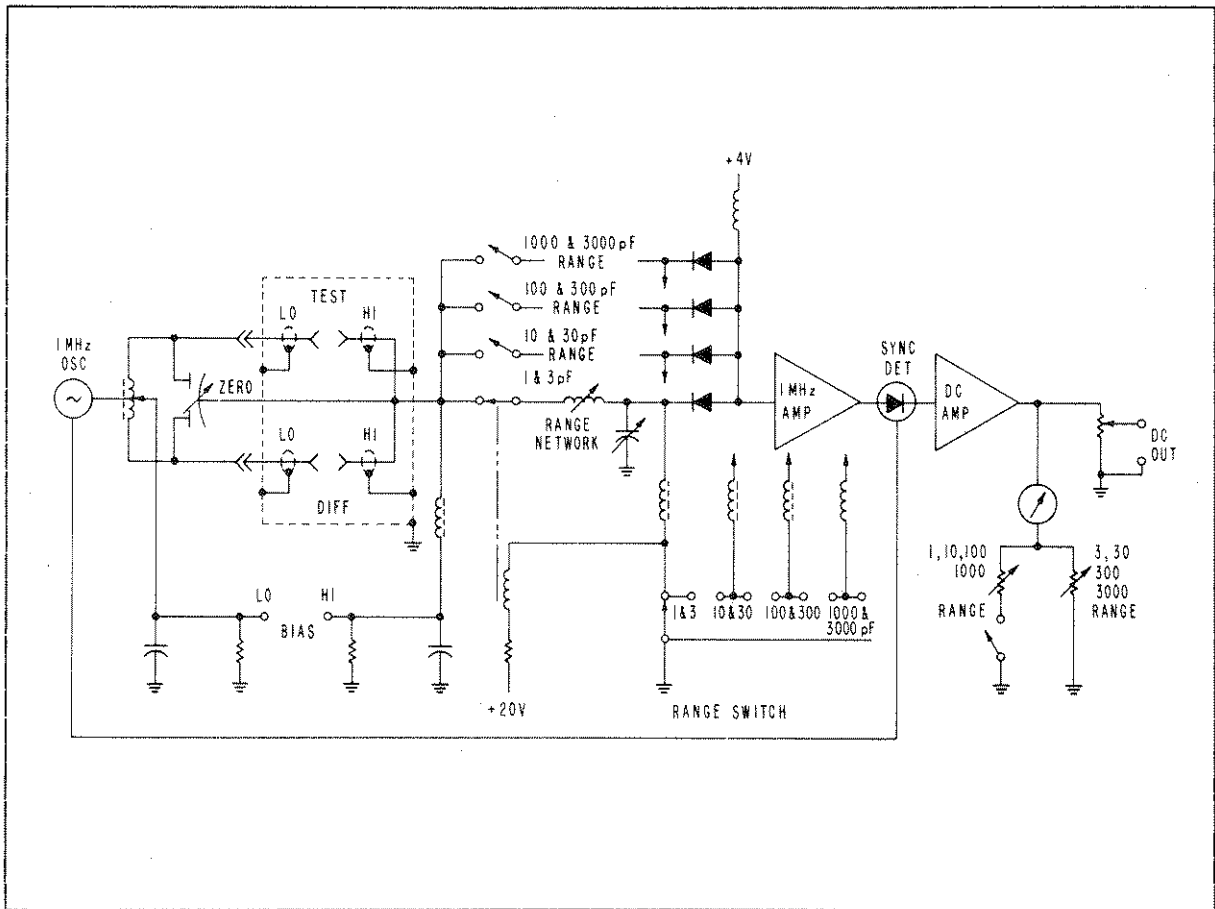

Figure 3-1. Simplified Schematic Diagram

With the instrument operating, and with both TEST and DIFF terminals open, the only signal appearing at the output of this section would be the result of the residual capacitances of the terminals and any fixtures connected to them. Adjustment of the differential capacitor (ZERO) balances out this signal, within the limits specified in §2-3C, resulting in zero output from the measuring section.

§3-2, Continued.

When a specimen capacitor is connected between the LO and HI TEST terminal a current directly proportional to its susceptance flows through the low-impedance series-resonant LC circuit to ground. (The appropriate resonant circuit is selected by the range-switching circuits.) The resultant voltage appearing across the capacitive part of the LC circuit is applied, through a tuned amplifier, to the synchronous detector.

The synchronous detector, gated by the crystal oscillator, converts the 1-MHz signal to d.c. and applies it to the d.c. amplifier section. The d.c. amplifier's output drives the panel meter; it also drives a voltage divider that supplies an adjustable analog output (both at the rear terminals and at the rear connector, P102), for external indication or control purposes.

### 3-3. RANGING CIRCUITS

Range switching in the 72B is accomplished by a combination of the panel range switch, switching diodes, and miniature reed relays. The panel switch handles only control voltages; no signal currents pass through it. This design eliminates a frequent source of errors, and improves reliability.

The switching diodes are biased "off" by the 2.4 V differential between the +6.6 V on the cathodes and the +4.2 V on the anodes. When contacts of the range switch are closed, the cathode of the appropriate diode is grounded for d.c. through an r.f. choke and a 10 k $\Omega$  resistor. As it then has a net positive bias on its anode, the diode is switched to the conducting state and thereby connects one end of its associated range network to the input of the 1 MHz amplifier. At the same time, the range switch energizes the associated reed relay through a logic circuit that then connects the other end of the range network to the output of the measuring section.

## SECTION IV

### MAINTENANCE

#### 4-1. GENERAL NOTES

A. The values and tolerances shown in this section are not specifications; they are provided only as guides to maintenance and calibration.

B. For all calibration checks, the 72B requires a warm-up of one hour, minimum.

#### 4-2. INTRODUCTION

The Model 72B is designed to operate within stated specifications over a long period. However, to achieve the maximum performance, it is desirable to check and adjust the instrument periodically. Basically, two adjustments are recommended:

A. A zero-balance check and adjustment every 500 hours of operation (three months of normal use).

B. A calibration check every 1000 hours of operation (six months of normal use).

In addition to these two periodic checks, complete adjustment procedures are described in §4-8 to §4-14. It is felt, however, that because of the complete calibration procedures performed at the BEC factory, these adjustments are not needed when the instrument is used in normal laboratory or factory environments. It is recommended they be performed only in case of accidental misadjustment, component failure and replacement, or when the instrument has been subjected to severe environmental stresses such as shock or vibration.

Complete schematics, a parts list, and component-location drawings are at the end of this manual and should be referred to for servicing.

#### 4-3. TEST EQUIPMENT REQUIRED

Test equipment required for maintenance and adjustment of the 72B is listed in Table 4-1. Other models of test equipment that meet or exceed critical specifications may be used instead.

#### 4-4. ZERO ADJUSTMENT

If, after the zero has been adjusted on the lowest range with the front-panel ZERO control, there is disagreement between the higher-range zeros, the following zero adjustment should be performed. No standards or test equipment are needed to perform this check and adjustment.

A. To check the zeros with no capacitance on the TEST terminal, set the 72B to its lowest range and adjust the front-panel ZERO control for zero indication. Now select all higher ranges and observe and record the meter indications on these ranges. The indications should not differ from zero by more than  $\pm 0.5\%$  f.s. If a zero indication does exceed these limits, proceed as follows:

B. Turn the instrument "off" and check the meter pointer with the 72B in its normal operating position. Adjust the meter zero (black screw below the dial) to indicate exactly zero.

C. Turn the 72B "on", connect the BNC adapter to the instrument, but use no capacitor, and adjust the front ZERO control on the 1 pF range until the 72B indicates zero.

D. Select the 1000 pF range and adjust R133 (at the rear of the 72B) until

§4-4D, Continued.

the instrument indicates zero on the 1000 pF range.

E. Set the instrument to the 1 pF range and adjust the front ZERO again. Now check all other ranges, which should be within the  $\pm 0.5\%$  f.s. limits.

If desired, the 1000 pF range zero (R133) may be reset slightly to make the maximum positive zero deviation equal to the maximum negative deviation. This procedure will minimize the zero error when the instrument is used on different ranges without front ZERO adjustment.

Table 4-1. Required Test Equipment for Maintenance and Adjustment

EQUIPMENT	CRITICAL SPECIFICATIONS	SUGGESTED MODEL
Digital D.C. Voltmeter	100 mV to 20 V. Minimum input resistance 1 M $\Omega$	Data Precision 1350
R.F. Millivoltmeter	1 mV to 1 V, 1 MHz minimum bandwidth	Boonton Electronics 92E with r.f. probe
High-Q/Low-Q Standard	100 pF $\pm 0.25\%$ , Q > 500 and Q = 3, at 1 MHz	(See Figure 4-3)
Capacitance Standards, 1 MHz	1000 pF $\pm 0.1\%$ 300 pF $\pm 0.1\%$ 100 pF $\pm 0.1\%$ 10 pF $\pm 0.1\%$ 1 pF $\pm 0.1\%$	BEC Model 953116 BEC Model 953115 BEC Model 953114 BEC Model 953112 BEC Model 953110
Loading Capacitor	200 pF $\pm 5\%$ , mica 500 pF $\pm 5\%$ , mica	

4-5. CALIBRATION CHECK

A. Allow a minimum of one hour warm-up. For the checks in the following paragraph, adjust the zero with the front ZERO control at every range prior to making measurements. Perform the Zero Adjustment (§4-4), if necessary.

B. Connect, one at a time, the 1, 10, 100, 300, and 1000 pF standards and check the errors on the corresponding ranges. These errors should not exceed 0.5% on any range. Record the indications.

C. Before making further adjustments, analyze the results. If all ranges have errors in the same direction and approximately by the same percentage, a simple test-level adjustment will correct the calibration. However, when ranges need adjustment in different directions (i.e., some have positive, some have negative errors), or by different amounts, they will have to be calibrated separately.

4-6. CALIBRATION ADJUSTMENT

A. Test-Level Adjustment. When all ranges have drifted by approximately the same amount, a single test-level adjustment may correct the calibra-

#### §4-6, Continued.

tion. For this adjustment, warm up the 72B, remove the top cover, select the 100 pF range, zero the range, and connect a 100 pF  $\pm 0.1\%$  standard to the TEST terminals. If the indication is not within 0.5% of the standard, adjust the ten-turn trimmer R202 on the amplifier plug-in board to obtain the correct reading within 0.1%. By this adjustment, indications on all ranges will be corrected by the same percentage. The test level is also changed by this adjustment, but this change usually is insignificant. The zeros of the ranges will not be affected.

The same result may be achieved by adjusting R142 on the 100 pF range (thus correcting all "1" ranges by the same percentage), and R146 on the 300 pF range (which corrects all "3" ranges by the same percentage).

**B. Range Adjustments.** For individual range adjustments, the instrument's bottom cover has to be removed in order to allow access to calibration adjustments C111, C117, and C121 on the lower left side of the instrument. To shield the instrument during these adjustments, the 72B should be set on a plain aluminum sheet; alternatively, use a test cover provided with the appropriate access holes.

1. The adjustments should always start with R202 (§4-6A) on the 100 pF range because this adjustment affects all other ranges.
2. For the 1000 pF range, connect the 1000 pF  $\pm 0.1\%$  standard to the TEST terminal and, using a 1/16" insulated screwdriver, adjust C121 for a reading within 0.1%.
3. For the 10 pF range, use a 10 pF standard and adjust C117.
4. For the 1 pF range, use a 1 pF standard and adjust C111.
5. For all "3" ranges, select the 300 pF range, use a 300 pF standard and adjust R146 (located at the rear of the instrument).

#### 4-7. NOTE: PERIODIC CALIBRATION

The procedures of §4-4 and 4-5 cover the recommended periodic calibration of the 72B. The adjustments in the following section are **not** recommended to be performed periodically.

#### 4-8. MAINTENANCE AND REPAIR ADJUSTMENTS

The following adjustments are factory adjustments that are not affected by aging or drift of the components, and are therefore expected to remain set during the life of the instrument. Furthermore, their influence on the 72B's accuracy is somewhat less than the influence of direct calibration adjustments. Therefore it is **not** recommended that the adjustments described below be made during periodic calibration routine. They have to be adjusted only in circumstances described in §4-2B, or when certain characteristics they affect are known to be out of specification. The characteristic that each adjustment affects, and the method of adjustment, are described below.

#### 4-9. POWER-SUPPLY ADJUSTMENTS R115 AND R118

Trimmer R115 should be adjusted to make the positive supply +15.0 V, within  $\pm 0.25$  V. Use R118 to adjust the negative supply to -15 V,  $\pm 0.25$  V.

#### 4-10. L102, L103, AND L104 LOADING ADJUSTMENT

The 72B is designed for three-terminal measurement; that is, it measures only the capacitive component between HI and LO terminals and ignores the "loading capacitance" from the HI terminal, or from the LO terminal, to ground. If fixtures or cables with high loading capacitances are used to connect the test capacitance to the 72B, and an error is introduced that is more than that specified due to capacitive loading, the loading adjustments L102, L103, and L104 have to be adjusted.

NOTE: When loading errors are intolerable (owing to inordinately large values of loading capacitance at either or both test terminals), the loading capacitance can be negated by means of a parallel in-

§4-10, Continued.

ductor connected between the center conductor and ground at the offended terminal(s). The combination of loading capacitance and shunt inductance should resonate at 1 MHz. Capacitance can be added in order to avoid non-standard inductance values.

A. Loading-Error Test. To test for loading error, special loading capacitors of 200 pF and 500 pF should be constructed according to Figure 4-1.

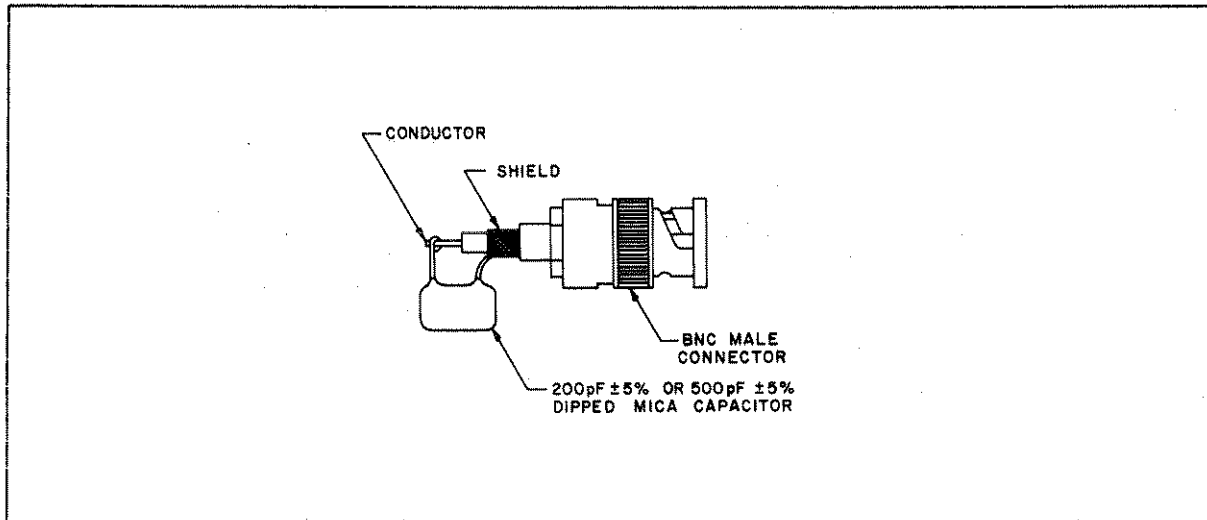

Figure 4-1. Special Loading Capacitor

To connect the loading capacitor and the test capacitor, use a BNC adapter with a BNC "Tee", as shown in Figure 4-2.

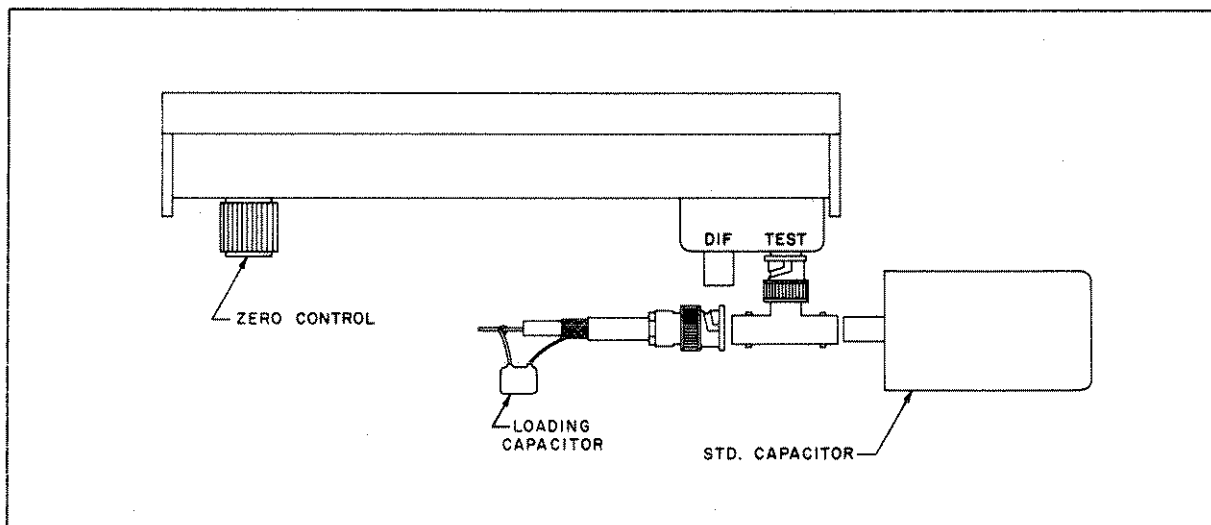

Figure 4-2. Loading Capacitor Test

For the loading test, select the desired range, connect the BNC Tee adapter as shown above, and zero the instrument with the front ZERO control.

Connect the standard capacitor to the right side of the Tee and record the instrument indication. Now disconnect the standard capacitor and connect the loading capacitor to the left side of the Tee on the HI terminal. Zero



§4-10A, Continued.

the instrument again, connect the standard capacitor to the right side of the Tee and measure the standard capacitor again. The difference between indications should be within the following limits:

<u>HI TERMINAL LOADING</u>	<u>RANGE</u>	<u>MAXIMUM DIFFERENCE</u>
200 pF	1 pF or 3 pF	0.5%
500 pF	10 pF and higher	0.25%

Should the HI terminal loading cause larger errors than those listed above, adjust the loading coils as follows.

B. L102, L103, and L104 Loading-Coil Adjustments. Select the proper range, proper standard, and proper loading capacitor. Only "1" ranges have to be checked, because the next higher "3" range uses the same input circuitry. Zero the 72B and measure the standard capacitor; record the result. Now remove the standard capacitor and connect the loading capacitor to the HI terminal. Zero the instrument again, then re-connect and re-measure the the standard capacitor. If the measured value does not agree with the previous measurement, adjust:

<u>LOADING ADJUSTMENT</u>	<u>RANGE</u>
L102	1, 3 pF
L103	10, 30 pF
L104	100, 300 pF

The 1000 pF range is adjusted with the 100 pF range adjustment.

The loading-coil adjustment may affect the calibration of the ranges to which it applies. Therefore, the calibration has to be checked (§4-5), and if required, adjusted (§4-6).

LO terminal loading should not change during the life of the instrument and should not have to be checked.

4-11. HIGH-Q/LOW-Q ADJUSTMENT C223, C228, AND T201

The 72B measures only the capacitive component, and ignores the resistive component, of the current between the HI and LO terminals. In order to accomplish this, the reference voltage to the phase detector should be in correct phase relationship to the signal voltage through the amplifier. Correct phase relationship is established by checking the instrument with high-Q and low-Q capacitors as follows.

A. High-Q/Low-Q Test. Set the 72B to the 100 pF range, zero, and connect the High-Q/Low-Q standard to the instrument. (The schematic diagram of a High-Q/Low-Q standard that is suitable for use at 1 MHz is shown in Figure 4-3.) Measure the capacitance in both the HI and LO Q position of the standard and compare the results. If they differ by more than 0.5%, the high-low Q adjustments need readjusting.

B. High-Low Q Adjustment. Set the 72B to its 100 pF range and zero with the front ZERO control. Connect the r.f. voltmeter to test point TP3 and measure the r.f. voltage, which is typically 10 - 30 mV. Adjust the phase-detector balance with C233 for a minimum indication on the r.f. voltmeter. Now connect the High-Q/Low-Q capacitance standard to the TEST terminal and make a measurement in the HI-Q position. Record the result. Make the same measurement in the standard's LO-Q position and adjust C228 until the HI and the LO Q measurements agree within 0.25%. If the range of C228 is not sufficient to bring the indications into agreement, the core of transformer T201 may be adjusted for the same purpose. In either case, take note that high-low Q adjustment may necessitate recalibration of the 100 pF range, as described in §4-6A.

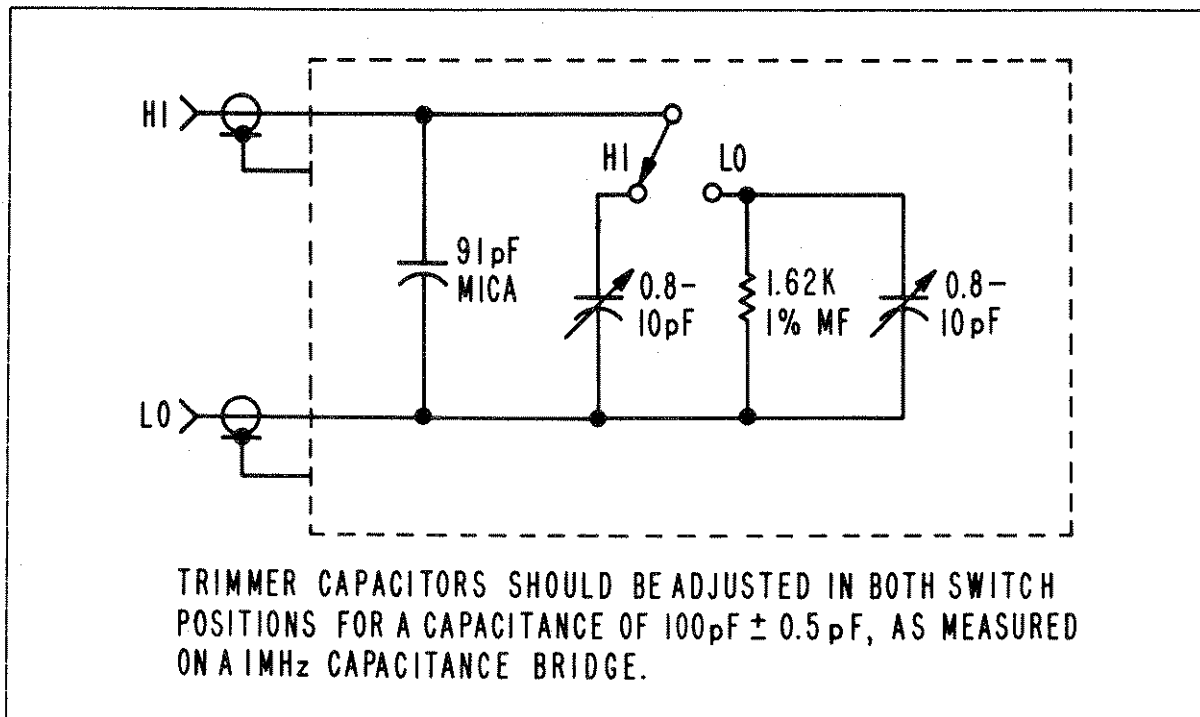

Figure 4-3. High-Q/Low-Q Standard

#### 4-12. T401, C202 TUNING

The input transformer, T401, should be tuned to the 1 MHz crystal for the proper operation of the oscillator. This may be accomplished by adjusting either the trimmer C202 or the transformer core. The core adjustment should be used only when the range of C202 is insufficient for proper adjustment.

To adjust the trimmer C202, remove the 72B's top cover and connect the d.c. voltmeter (10 V range), to TP1 on the amplifier plug-in board. Now adjust C202 for a maximum voltage, typically +7 to +12 V, d.c.

If the maximum cannot be reached by adjusting C202, the core of transformer T401 can be adjusted. This adjustment is available at the bottom of T401 by removing the bottom cover of the 72B. Set C202 to the midpoint of its range, and vary T401's core adjustment to achieve a maximum d.c. voltage as measured at TP1.

Following either of the above adjustments, the 72B should be calibrated as described in §4-6A.

#### 4-13. TEST-VOLTAGE SYMMETRY ADJUSTMENT

The single-turn secondary of transformer T401 has an adjustable center tap by which the test voltage on TEST and DIFF terminals can be adjusted to be equal. The equality of TEST and DIFF voltages is important when an external standard is connected to the DIFF terminals for differential measurements. Normally the TEST and DIFF voltages are adjusted to be equal within 0.25%.

To adjust the symmetry, remove the top and bottom covers. Connect the d.c. digital voltmeter to TP2 on the oscillator amplifier plug-in board. Adjust the front ZERO for zero indication on the DVM. Plug a 100 pF capacitance standard to the TEST and DIFF terminals and observe the voltmeter's indication. The voltmeter should indicate approximately +0.5 V at the TEST terminal, and -0.5 V at the DIFF terminal. Using a 1/16" screwdriver, adjust T401 (at the right side of the 72B), until the magnitude of both these voltages is exactly equal.



#### 4-14. 1 MHz AMPLIFIER TUNING (L201 ADJUSTMENT)

For accurate adjustment of L201, the 1 MHz amplifier should be operated without overall feedback by unsoldering the link between the two solder terminals next to the L201 coil. Now the amplifier gain is increased by about 30 dB and the frequency response is sharply peaked at 1 MHz.

To adjust L201, set the 72B to the 100 pF range, connect the r.f. voltmeter to TP3, and adjust the ZERO control until the voltmeter indicates 0.2 to 0.5 V. Adjust the core of L201 (from the rear of the amplifier board) with a 1/16" insulated screwdriver, to peak the voltmeter indication. Resolder the link removed above. Perform the test-level adjustment (§4-6A).

#### 4-15. TROUBLESHOOTING: GENERAL

Should the 72B fail or malfunction, a two-step approach to troubleshooting and repair is recommended: identify the defective section; and troubleshoot and repair the section.

The instruments listed in Table 4-1 will serve also for troubleshooting. The only point for attention is terminal D--input to the 1 MHz amplifier. The signal level there (under normal operating conditions), is 150  $\mu$ V at 1 MHz for a full-scale indication on every "1" range. This signal is too low to be measured accurately with the recommended instrumentation. Therefore, introduce a  $\times 10$  overload (100 pF test capacitor on the 10 pF range) to bring this level to a measurable range, for testing ranging circuitry.

#### 4-16. IDENTIFICATION OF DEFECTIVE SECTION

To identify the defective section, use the troubleshooting block diagram (Figure 6-1), and the simplified troubleshooting schematic diagram (Figure 6-2). These diagrams should be sufficient to guide you through a logical troubleshooting sequence.

#### 4-17. TROUBLESHOOTING DEFECTIVE SECTIONS

Figure 6-2 should be used to find the pertinent signal- and d.c.-voltage levels. This information, together with specific tests recommended in the following paragraphs, should enable an experienced troubleshooter to locate and repair defective components.

##### A. Power Supply. Normal output levels are as follows:

+15 V supply, (at the positive terminal of C128), +15 V  $\pm 0.25$  V;  
-15 V supply, (at the negative terminal of C129), -15 V  $\pm 0.25$  V.

When the output voltage cannot be set within the specified limit, check for an external "short" by checking the temperature of the series regulators (IC101, 102, and 103). High temperatures indicate external shorts; a cool regulator indicates trouble in the power supply--or normal operation.

##### B. 1 MHz Oscillator. Normal operating levels are

at LO terminal: 1 MHz, 15 mV  $\pm 2$  mV  
at TP1: +7.5 to +12 V, d.c.  
at J101, pin X: 3.4 V, r.m.s., 1 MHz

Check C202 or T401 tuning (§4-12). When grossly out of tune, the oscillator will not oscillate.

C. Ranging Circuitry. Ranges are selected by reed relays K101 to K103 and switching diodes CR109 to CR112. If a particular range is activated, that range's reed relay is closed and its associated switching diode is forward biased. Normal voltage levels are as follows:

	<u>Pin 3 or pin 5 of IC106 or IC107</u>	<u>Pin D of J101</u>
Range Activated	0 V	4.2 V
Range Not Activated	+20 V	4.2 V

§4-17C, Continued.

If the voltage on pin 3 or pin 5 of IC106 or IC107 is pulled down when the proper range is selected, but the range is not activated properly, look for trouble in the reed relays, diodes CR109-CR112, and associated circuitry.

If pin 3 or 5 voltage is not pulled down by range selection, the trouble is in the range switch, ranging lines, or in IC106 and/or IC107.

The "3" ranges are selected by decreasing indicator M101 current by opening K104 contact.

D. 1 MHz Amplifier. The amplifier is a tuned feedback amplifier with a closed-loop gain of approximately 70 dB. The open-loop gains by stages are

First Stage (Q203 and Q204):	54 dB
Second Stage (Q205):	23 dB
Third Stage (Q207):	23 dB

An output level of 0.5 V at TP3 is produced by an input level of 150  $\mu$ V at pin D of J201; the input level is too low to measure accurately with normal instrumentation.

To troubleshoot the amplifier, check d.c. operating voltages and signal levels as shown in Figure 6-2. Replace defective components, if necessary. If this does not restore normal gain, check L201's tuning (§4-14).

The condition in which the 72B operates normally in one or more ranges (but not in all ranges), indicates that the trouble is in the ranging circuitry. The amplifier should not be serviced in that case.

E. Phase-Sensitive Detector. The phase-sensitive detector circuitry consists of bridge circuit CR205-CR208, and overload detector Q208 and Q209. Normal operating levels at full scale (100 pF on the 100 pF range) are:

1 MHz Amplifier Output TP3:	500 mV, 1 MHz
Detector Output at TP2:	+0.5 V, d.c.
Phase-Reference Drive at C228:	10 V, 1 MHz

When the 72B is zeroed, the phase-detector output at TP2 should be 0 mV.

Normal overload sensor voltage on pin S, J101, is -15 V when indication is on-range (1 MHz amplifier output at TP3 of 1.5 V, 1 MHz). With an overload condition (TP3 voltage above 1.8 V), the pin-S voltage should change to +12 volts.

F. Phase-Reference Channel. The phase-reference channel consists of the reference amplifier Q206, and a voltage-divider and phase-shifting network. Normal operating levels are

Input (Q206 base):	4.8 V, 1 MHz
Output at T201 secondary:	10 V, 1 MHz

T201 is tuned for maximum output at 1 MHz, and finally adjusted for correct phase (§4-11).

G. Output Amplifier. Operational amplifier A101 drives the meter circuit and the analog output. Normal operating levels (with 100 pF on the 100 pF range), are

Input at pin 3:	+0.5 V
Output at pin 6:	+3.67 V

An overload signal causes the amplifier to clamp to a maximum positive output; the overload signal is then applied to pin 8, whose normal voltage (up to 1.5 V at pin 3) is 0, and whose overload voltage (above 1.8 V at pin 3) is up to +12 V.

The input and output voltage of the 72B's output amplifier will be zero if there is zero input to the 72B and the instrument is properly zeroed.

**4-18. EXTERNAL PIN ASSIGNMENTS**

Rear-panel connector P102 makes available +15 V and +5 V for use with BEC options; it also provides an analog output for a recorder. In addition, pins are available for the following purposes: (1) for the connection of external voltage supplies to bias the HI and/or LO terminal; (2) for remote ranging. See Table 4-2 and Figure 4-4 for pin locations and descriptions.

Table 4-2. External Pin Assignments

TERMINAL	FUNCTION	REMARKS
A	+15 V	Power for BEC-supplied options only
B	+5 V	" " " " " "
1	±HI terminal bias	±200 V, d.c., maximum
2	±LO terminal bias	±400 V, d.c., maximum
3	Ground	
4	+ Analog output	+1 V, f.s., 1-10-100-1000 range +3 V, f.s., 3-30-300-3000 range Z = 1 kΩ
5	Ground	
7	Manual disable	Connect to ground to disable front-panel programming
9	3000 pF range	Pins 9-16 are external range-programming inputs. Logic 0, or connection to common, selects corresponding range. These lines may be used as outputs to indicate current operating range: the range line corresponding to the operating range will be at logic 0 (logic 0 < +0.5 V).
10	1000 pF range	
11	300 pF range	
12	100 pF range	
13	30 pF range	
14	10 pF range	
15	3 pF range	
16	1 pF range	

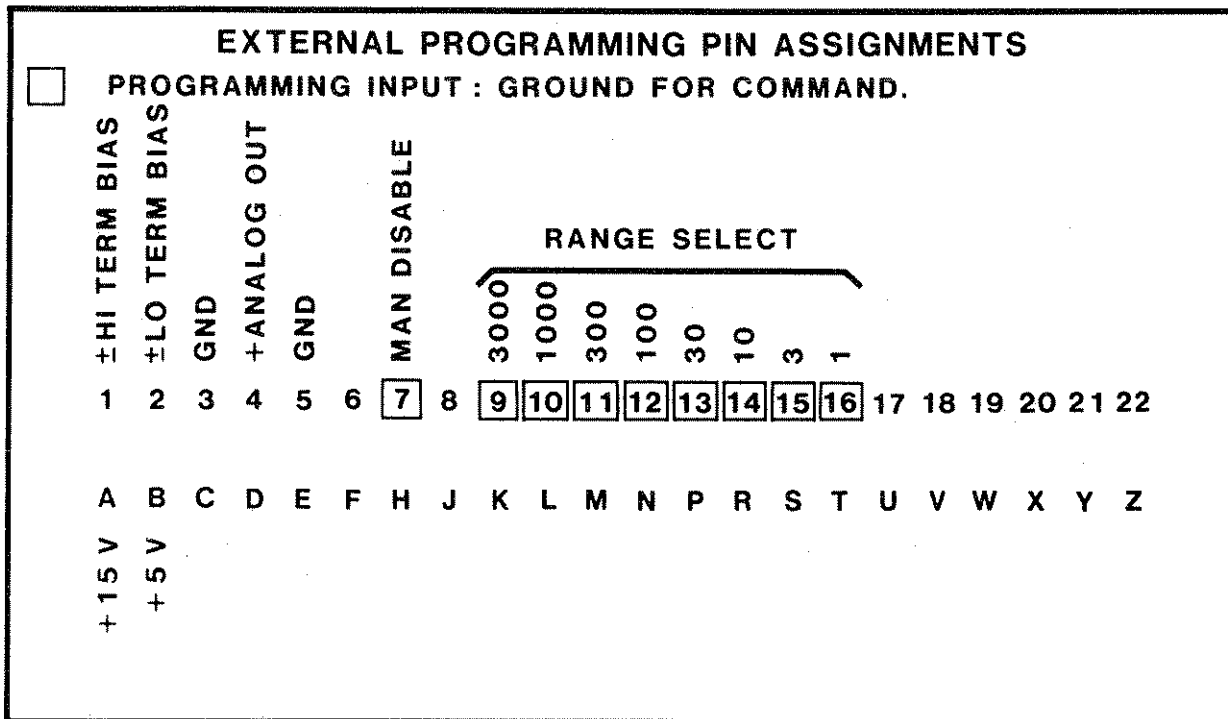

Figure 4-4. External Connections

## SECTION V

### REPLACEABLE PARTS

#### 5-1. INTRODUCTION

Table 5-2, Replaceable Parts, identifies the manufacturers of components by five-digit groups taken from the Federal Supply Code for Manufacturers. A list of the applicable code groups and manufacturers is given in Table 5-1.

The Table of Replaceable Parts begins with major assemblies, including PC boards complete with all their parts, followed by miscellaneous parts and components not mounted on PC boards. Then all the components of the individual assemblies (including PC boards) are listed.

To simplify ordering, please note the following:

- A. When ordering a component or an assembly, the BEC Part Number is all that we need. However, part numbers can suffer changes during transmission and it is safer to include also a brief description. Examples:
  - 1) BEC Part #200050: Mica Capacitor, 470 pF, 1%, 500V.
  - 2) BEC Part #102409: Oscillator PC Board Assembly.
- B. The number printed on a PC board is not an assembly number; it is the number for the bare board, alone. To order a complete assembly--the board with all its components installed--specify it by the BEC Part Number given in the Assemblies Section of this table.
- C. Unless otherwise identified, the number on a schematic diagram or on a parts-location diagram is not an assembly number; it is the number for just the diagram itself.

Table 5-1. Manufacturers' Federal Supply Code Numbers

NUMBER	NAME	NUMBER	NAME
00213	Nytronics	27735	F-Dyne Electronics
00241	Fenwal Electronics	32897	Erie
01121	Allen Bradley	32997	Bourns, Inc., Trimpot Div.
01295	Texas Instruments	33883	RMC
02660	Amphenol	34430	Monsanto
04222	AVX	54426	Buss Fuses
04713	Motorola Semiconductor	56289	Sprague Electric
04901	Boonton Electronics	57582	Kahgan Electronics
06776	Robinson Nugent	71450	CTS Corp.
07263	Fairchild Semiconductor	73138	Beckman Instr., Helipot Div.
14655	Cornell-Dubilier	74970	E.F. Johnson
16482	Belden	78526	Stanwyck
17117	Electronic Molding	81840	Ledex, Inc.
19701	Mepco Electronics	83330	H.H. Smith
20307	Arco (Micronics)	91637	Dale Electronics
27014	National Semiconductor	96804	J.W. Miller
27264	Molex, Inc.	98291	Sealectro Corp.

Replaceable Parts List for Front Sub Panel Assembly  
Reference

PL 072002-050

Symbol	Description	Mfr.	Mfr's Part No.	BEC Part No.
C404	Capacitor Var 1.8-8.7 pF	74970	160-0305-001	275138-000
CR401	Diode LED Red Diffused	34430	MV5025	536000-000
J411	Connector Female	27264	Reel #02-06-1231	479320-000
J412	Connector Female	27264	Reel #02-06-1231	479320-000
J413	Connector Female	27264	Reel #02-06-1231	479320-000
J414	Connector Female	27264	Reel #02-06-1231	479320-000
J415	Connector Female	27264	Reel #02-06-1231	479320-000
J416	Connector Female	27264	Reel #02-06-1231	479320-000
J417	Connector Female	27264	Reel #02-06-1231	479320-000
J418	Connector Female	27264	Reel #02-06-1231	479320-000
J424	Connector Female	27264	Reel #02-06-1231	479320-000
J425	Connector Female	27264	Reel #02-06-1231	479320-000
J426	Connector Female	27264	Reel #02-06-1231	479320-000
M101	Meter & Scale M/F 554247, 554248	04901	BEC	554249-000
P402A	Banana Plug with Stud 6/32 x 3/4	83330	416	477178-000
P402B	Banana Plug with Stud 6/32 x 3/4	83330	416	477178-000
S401	Switch Rocker (white) ON/OFF	04426	RSW-04-22-SD-BB-S-W1-BK	465203-000
T401	Oscillator Transformer Assembly	04901	BEC	072006-030

Replaceable Parts List for Rear Panel Assembly  
Reference

PL 072003-040

Symbol	Description	Mfr.	Mfr's Part No.	BEC Part No.
C402	Capacitor Cer 0.01 µF 20% 1000V	56289	C023A102J103M (5GA-S10)	224228-000
C403	Capacitor Cer 0.01 µF 20% 1000V	56289	C023A102J103M (5GA-S10)	224228-000
C406	Capacitor Cer 1000 pF 10% 200V	61637	C052C102K2X5CA (MIL CK05)	224289-000
F401	Fuse 0.1 A Slo-Blo	54426	MDL	545519-000
F401	Fuse 0.2 A	54426	MDL 0.2	545508-000
F402	Fuse 1/32 250V	54426	AGC	545525-000
F403	Fuse 1/32 250V	54426	AGC	545525-000
J401	Connector Female	27264	Reel #02-06-1231	479320-000
J406	Connector Female	27264	Reel #02-06-1231	479320-000
J407	Connector Female	27264	Reel #02-06-1231	479320-000
J408	Connector Female	27264	Reel #02-06-1231	479320-000
J409	Connector Female	27264	Reel #02-06-1231	479320-000
J410	Connector Female	27264	Reel #02-06-1231	479320-000
J427	Connector Female	27264	Reel #02-06-1231	479320-000
J428	Connector Female	27264	Reel #02-06-1231	479320-000
J429	Connector Female	27264	Reel #02-06-1231	479320-000
J430	Connector Female	27264	Reel #02-06-1231	479320-000
J431	Connector Female	27264	Reel #02-06-1231	479320-000
J432	Connector Female	27264	Reel #02-06-1231	479320-000
P401	Connector Line Cord	16482	17252	477281-000
R401	Resistor Comp 510k ohm 5%	01121	EB	344568-000
R402	Resistor Comp 240k ohm 5%	01121	EB	344537-000
S402	Switch	81840	Series 210	466230-000
T402	Transformer Power	04901	BEC	446071-000

Replaceable Parts List for Master Board Assembly  
Reference

PL 072021-000

Symbol	Description	Mfr.	Mfr's Part No.	BEC Part No.
*	* SELECTED PART			
A101	IC LM301AN Op Amp	27014	LM301AN	535012-000
C101	Capacitor PC 0.1 µF 10% 630V	19701	C280CG/A100K	234091-000
C102	Capacitor PC 0.15 µF 10% 630V	19701	C280MCG/A150K	234147-000
C103	Capacitor Mica 82 pF 1% 500V	15281	RDM15-ED820F03	200107-000
C104	Capacitor Mica 100 pF 5% 500V	20307	DM15-F101J	200001-000
C105	Capacitor Mica 910 pF 1% 100V	15281	RDM15-FA911F03	200075-000
C106	Capacitor Mica 0.01 µF 1% 300V	15281	RDM30-FD103F03	203017-000
C107	Capacitor Mica 5 pF ±1 pf 500V	20307	DM10-C050	200043-000
C107	Capacitor Mica 10 pF 5% 500V	20307	DM10-C100J	200022-000
C108	Capacitor EL 2200 µF -10%/+50% 35V	57582	KSMH-2200-35	283351-000
C109	Capacitor EL 2200 µF -10%/+50% 35V	57582	KSMH-2200-35	283351-000
C111	Capacitor Var Cer 2.0 - 6.0 pF (red)	52769	GKR6R000	281015-000
C112	Capacitor Mica 68 pF 5% 500V	20307	DM15-680J	200031-000
C113	Capacitor Mica 82 pF 1% 500V	15281	RDM15-ED820F03	200107-000
C114	Capacitor Mica 680 pF 1% 300V	20307	DM15-F681F	200015-000
C115	Capacitor Cer 0.001 µF 500V	33883	Z5U B-GP Short Dip	224114-000
C116	Capacitor Mylar 0.1 µF 10% 100V (only)	19701	C280MAH/A100K (only)	234080-000
C117	Capacitor Var 5.1-50 pF 250V	52769	GKR50000	281006-000
C118	Capacitor Mylar 0.1 µF 10% 100V (only)	19701	C280MAH/A100K (only)	234080-000
C119	Capacitor Cer 0.001 µF 500V	33883	Z5U B-GP Short Dip	224114-000
C120	Capacitor Mylar 0.1 µF 10% 100V (only)	19701	C280MAH/A100K (only)	234080-000
C121	Capacitor Var 5.1-50 pF 250V	52769	GKR50000	281006-000
C122	Capacitor Mylar 0.1 µF 10% 100V (only)	19701	C280MAH/A100K (only)	234080-000
C123	Capacitor Cer 0.001 µF 500V	33883	Z5U B-GP Short Dip	224114-000
C124	Capacitor Cer 0.001 µF 500V	33883	Z5U B-GP Short Dip	224114-000
C125	Capacitor Cer 0.001 µF 500V	33883	Z5U B-GP Short Dip	224114-000
C127	Capacitor Mylar 0.1 µF 10% 100V (only)	19701	C280MAH/A100K (only)	234080-000



Replaceable Parts List for Master Board Assembly  
Reference

PL 072021-000

Symbol	Description	Mfr.	Mfr's Part No.	BEC Part No.
C128	Capacitor EL 100 µF 25V	56289	TE-1211 (300107G025002)	283105-000
C129	Capacitor EL 100 µF 25V	56289	TE-1211 (300107G025002)	283105-000
C130	Capacitor Mica 30 pF 5% 500V	20307	DM10-300J	200073-000
C131	Capacitor Mylar 0.1 µF 10% 100V (only)	19701	C280MAH/A100K (only)	234080-000
C132	Capacitor PE 0.022 µF 20% 250V	19701	C280AE/P22K	234079-000
C135	Capacitor Cer 1.0 µF 20% 50V	04222	SR305E105MAA	224264-000
C136	Capacitor Cer 1.0 µF 20% 50V	04222	SR305E105MAA	224264-000
C137	Capacitor Tant 1 µF 10% 35V only	56289	1960105X9035HA1 only	283216-000
C138	Capacitor Tant 1 µF 10% 35V only	56289	1960105X9035HA1 only	283216-000
C134*	Capacitor Mica 3 pF ±0.5 pF 300V	20307	DM5-CC030D	205013-000
C134*	Capacitor Mica 5 pF 10% 300V	20307	DM5-CC050K	205000-000
CR101	Diode 1N914	01295	1N914	530058-000
CR102	Diode 1N914	01295	1N914	530058-000
CR103	Diode 1N914	01295	1N914	530058-000
CR104	Diode Bridge KBP-02	20307	KBP-02	532013-000
CR105	Diode Bridge KBP-02	20307	KBP-02	532013-000
CR107	Diode 1N914	01295	1N914	530058-000
CR108	Diode 1N914	01295	1N914	530058-000
CR109	Diode FDH-300	07263	FDH300 (WIV 125)	530052-000
CR110	Diode FDH-300	07263	FDH300 (WIV 125)	530052-000
CR111	Diode FDH-300	07263	FDH300 (WIV 125)	530052-000
CR112	Diode FDH-300	07263	FDH300 (WIV 125)	530052-000
CR113	Diode Zener 1N5230B 4.7V	04713	1N5230B	530103-000
CR114	Diode 1N914	01295	1N914	530058-000
CR115	Diode 1N914	01295	1N914	530058-000
IC101	IC µA7805UC Regulator	07263	µA7805UC	535011-000
IC102	IC µA7805UC Regulator	07263	µA7805UC	535011-000
IC104	IC LM723CN Regulator	27014	LM723CN	535037-000
IC105	IC LM723CN Regulator	27014	LM723CN	535037-000
IC106	IC SN75451AP	01295	SN75451AP	534006-000
IC107	IC SN75451AP	01295	SN75451AP	534006-000
IC108	IC SN75451AP	01295	SN75451AP	534006-000
IC110	IC N8471A	10324	N8471A	534005-000
J101	Connector 22 Pin	02660	143-022-07	479231-000
K101	Relay Coil M/F 802151	04901	BEC	470502-000
K102	Relay Coil M/F 802151	04901	BEC	470502-000
K103	Relay Coil M/F 802151	04901	BEC	470502-000
K104	Relay Coil M/F 802151	04901	BEC	470502-000
L101	Inductor 560 µH	7852G	DINK-560	400183-000
L102	Inductor Var 28-60 µH	96804	9054	400377-000
L103	Inductor Var 14-28 µH	96804	9053	400231-000
L104	Inductor Var 1.5-3 µH	96804	9050	400232-000
L105	Inductor 4.7 µH 10%	00213	WEE-4.7 µH	400113-000
L106	Inductor 2.2 mH	00213	WEE-2200	400141-000
L107	Inductor 2.2 mH	00213	WEE-2200	400141-000
L108	Inductor 2.2 mH	00213	WEE-2200	400141-000
L109	Inductor 2.2 mH	00213	WEE-2200	400141-000
L110	Inductor 2.2 mH	00213	WEE-2200	400141-000
L111	Inductor 2.2 mH	00213	WEE-2200	400141-000
L112	Inductor 220 µH 5%	59474	1315-20J	400319-000
P101	Connector Pin (male)	98291	229-1086-000-550	477240-000
P105	Connector Pin (male)	98291	229-1086-000-550	477240-000
P106	Connector Pin (male)	98291	229-1086-000-550	477240-000
P107	Connector Pin (male)	98291	229-1086-000-550	477240-000
P108	Connector Pin (male)	98291	229-1086-000-550	477240-000
P109	Connector Pin (male)	98291	229-1086-000-550	477240-000
P110	Connector Pin (male)	98291	229-1086-000-550	477240-000
P111	Connector Pin (male)	98291	229-1086-000-550	477240-000
P112	Connector Pin (male)	98291	229-1086-000-550	477240-000
P113	Connector Pin (male)	98291	229-1086-000-550	477240-000
P114	Connector Pin (male)	98291	229-1086-000-550	477240-000
P115	Connector Pin (male)	98291	229-1086-000-550	477240-000
P116	Connector Pin (male)	98291	229-1086-000-550	477240-000
P117	Connector Pin (male)	98291	229-1086-000-550	477240-000
P123	Connector Pin (male)	98291	229-1086-000-550	477240-000
P124	Connector Pin (male)	98291	229-1086-000-550	477240-000
P125	Connector Pin (male)	98291	229-1086-000-550	477240-000
P126	Connector Pin (male)	98291	229-1086-000-550	477240-000
P127	Connector Pin (male)	98291	229-1086-000-550	477240-000
P128	Connector Pin (male)	98291	229-1086-000-550	477240-000
P129	Connector Pin (male)	98291	229-1086-000-550	477240-000
P130	Connector Pin (male)	98291	229-1086-000-550	477240-000
P131	Connector Pin (male)	98291	229-1086-000-550	477240-000
R103	Resistor Comp 1.3k ohm 5%	01121	EB	344311-000
R104	Resistor Comp 100k ohm 5%	01121	EB	344500-000
R105	Resistor Comp 100k ohm 5%	01121	EB	344500-000
R106	Resistor Comp 5.1k ohm 5%	01121	EB	344368-000
R107	Resistor Comp 1.0k ohm 5%	01121	CB	343300-000
R108	Resistor Comp 1.0k ohm 5%	01121	CB	343300-000
R109	Resistor Comp 2.0k ohm 5%	01121	EB	344329-000
R110	Resistor Comp 10k ohm 5%	01121	FB	344400-000
R111	Resistor Comp 10k ohm 5%	01121	EB	344400-000
R112	Resistor Comp 10k ohm 5%	01121	EB	344400-000

Replaceable Parts List for Master Board Assembly

PL 072021-000

Reference

Symbol	Description	Mfr.	Mfr's Part No.	BEC Part No.
R113	Resistor Comp 10k ohm 5%	01121	EB	344400-000
R114	Resistor MF 3.32k ohm 1%	---	RN550-3321-F	341350-000
R115	Resistor Var 1k ohm 10% 0.5W	73138	72PR1K	311316-000
R116	Resistor MF 3.01k ohm 1%	---	RN550-3011-F	341346-000
R117	Resistor MF 3.32k ohm 1%	---	RN550-3321-F	341350-000
R118	Resistor Var 1k ohm 10% 0.5W	73138	72PR1K	311316-000
R119	Resistor MF 3.01k ohm 1%	---	RN550-3011-F	341346-000
R120	Resistor Comp 1.2k ohm 5%	01121	EB	344308-000
R121	Resistor Comp 3.9k ohm 5%	01121	CB	343357-000
R122	Resistor Comp 3.9k ohm 5%	01121	CB	343357-000
R123	Resistor Comp 3.9k ohm 5%	01121	CB	343357-000
R124	Resistor Comp 5.1k ohm 5%	01121	CB	343368-000
R125	Resistor Comp 5.1k ohm 5%	01121	CB	343368-000
R126	Resistor Comp 5.1k ohm 5%	01121	CB	343368-000
R127	Resistor Comp 5.1k ohm 5%	01121	CB	343368-000
R128	Resistor Comp 5.1k ohm 5%	01121	CB	343368-000
R129	Resistor Comp 5.1k ohm 5%	01121	CB	343368-000
R130	Resistor Comp 5.1k ohm 5%	01121	CB	343368-000
R131	Resistor Comp 5.1k ohm 5%	01121	CB	343368-000
R132	Resistor MF 10.0k ohm 1%	---	RN550-1002-F	341400-000
R133	Resistor Var 20k ohm 10% 1W	91637	*784	311266-000
R134	Resistor Comp 4.7M ohm 5%	01121	EB	344665-000
R135	Resistor Comp 10M ohm 5%	01121	CB	343700-000
R137	Resistor Comp 10k ohm 5%	01121	EB	344400-000
R138	Resistor MF 63.4k ohm 1%	---	RN550-6342-F	341477-000
R139	Resistor MF 10.0k ohm 1%	---	RN550-1002-F	341400-000
R140	Resistor MF 3.32k ohm 1%	---	RN550-3321-F	341350-000
R141	Resistor MF 26.1k ohm 1%	---	RN550-2612-F	341440-000
R142	Resistor Var 5k ohm 10% 1W	91637	*784	311268-000
R143	Resistor Comp 1.3k ohm 5%	01121	EB	344311-000
R144	Resistor Var 200 ohm 10% 1W	91637	*784	311269-000
R145	Resistor MF 54.9k ohm 1%	---	RN550-5492-F	341471-000
R146	Resistor Var 5k ohm 10% 1W	91637	*784	311268-000
R147	Resistor MF 1.21k ohm 1%	---	RN550-1211-F	341308-000
R148	Resistor Comp 4.7k ohm 5%	01121	EB	344365-000
R149	Resistor Comp 1.8k ohm 5%	01121	CB	343325-000
R150	Resistor Comp 1.8k ohm 5%	01121	CB	343325-000
R151	Resistor Comp 1.3k ohm 5%	01121	EB	344311-000
XA101	Socket IC 8 Pin	06776	ICN-083-S3-G	473041-000
XU104	Socket IC 14 Pin	06776	ICN-143-S3-G	473019-000
XU105	Socket IC 14 Pin	06776	ICN-143-S3-G	473019-000
XU106	Socket IC 8 Pin	06776	ICN-083-S3-G	473041-000
XU107	Socket IC 8 Pin	06776	ICN-083-S3-G	473041-000
XU108	Socket IC 8 Pin	06776	ICN-083-S3-G	473041-000
XU110	Socket IC 14 Pin	06776	ICN-143-S3-G	473019-000

Replaceable Parts List for Oscillator Amplifier Board Assembly

PL 072022-000

Reference

Symbol	Description	Mfr.	Mfr's Part No.	BEC Part No.
*	* SELECTED PART			
A201	IC LM301AN Op Amp	27014	LM301AN	535012-000
C201	Capacitor Cer 0.001 µF 500V	33883	Z5U B-GP Short Dip	224114-000
C202	Capacitor Var 5.1-50 pF 250V	52769	GKRS0000	281006-000
C204	Capacitor Cer 0.001 µF 500V	33883	Z5U B-GP Short Dip	224114-000
C205	Capacitor Mylar 0.1 µF 10% 100V (only)	19701	C280MAH/A100K (only)	234080-000
C206	Capacitor Cer 0.001 µF 500V	33883	Z5U B-GP Short Dip	224114-000
C207	Capacitor Mylar 0.1 µF 10% 100V (only)	19701	C280MAH/A100K (only)	234080-000
C209	Capacitor Mica 250 pF 5% 500V	20307	DM15-251J	200036-000
C210	Capacitor Mica 30 pF 5% 500V	20307	DM10-300J	200073-000
C211	Capacitor Cer 0.01 µF 100V	32897	805-000XSV0103Z	224119-000
C212	Capacitor Mylar 0.1 µF 10% 100V (only)	19701	C280MAH/A100K (only)	234080-000
C213	Capacitor Mica 160 pF 5% 500V	20307	DM15-161J	200048-000
C214	Capacitor Mica 82 pF ± 5% 500V	20307	DM15-820J	200074-000
C215	Capacitor Mylar 0.1 µF 10% 100V (only)	19701	C280MAH/A100K (only)	234080-000
C216	Capacitor Cer 0.001 µF 500V	33883	Z5U B-GP Short Dip	224114-000
C217	Capacitor Cer 0.01 µF 100V	32897	805-000XSV0103Z	224119-000
C218	Capacitor Mica 39 pF 5% 500V	20307	DM15-E390J	200025-000
C219	Capacitor Mica 39 pF 5% 500V	20307	DM15-E390J	200025-000
C220	Capacitor Cer 0.001 µF 500V	33883	Z5U B-GP Short Dip	224114-000
C221	Capacitor Mylar 0.1 µF 10% 100V (only)	19701	C280MAH/A100K (only)	234080-000
C222	Capacitor Mylar 0.1 µF 10% 100V (only)	19701	C280MAH/A100K (only)	234080-000
C223	Capacitor Mylar 0.1 µF 10% 100V (only)	19701	C280MAH/A100K (only)	234080-000
C224	Capacitor Mylar 0.1 µF 10% 100V (only)	19701	C280MAH/A100K (only)	234080-000
C225	Capacitor Mylar 0.1 µF 10% 100V (only)	19701	C280MAH/A100K (only)	234080-000
C226	Capacitor Mylar 0.1 µF 10% 100V (only)	19701	C280MAH/A100K (only)	234080-000
C227	Capacitor Mylar 0.1 µF 10% 100V (only)	19701	C280MAH/A100K (only)	234080-000
C228	Capacitor Var 2.5-2.0 pF 250V (blue)	52769	GKR20000	281005-000
C229	Capacitor Mylar 0.1 µF 10% 100V (only)	19701	C280MAH/A100K (only)	234080-000
C230	Capacitor Mica 680 pF 1% 300V	20307	DM15-F681F	200015-000
C231	Capacitor Mica 680 pF 1% 300V	20307	DM15-F681F	200015-000



Replaceable Parts List for Oscillator Amplifier Board Assembly

PL 072022-000

Reference

Symbol	Description	Mfr.	Mfr's Part No.	BEC Part No.
C232	Capacitor Mica 39 pF 5% 500V	20307	DM15-E390J	200025-000
C233	Capacitor Var 5.1-50 pF 250V	52769	GKRS0000	281006-000
C234	Capacitor PE 0.022 μF 20% 250V	19701	C280AE/P22K	234079-000
C235	Capacitor PE 0.022 μF 20% 250V	19701	C280AE/P22K	234079-000
C236	Capacitor Cer 0.001 μF 500V	33883	Z5U B-GP Short Dip	224114-000
C237	Capacitor PE 0.022 μF 20% 250V	19701	C280AE/P22K	234079-000
C238	Capacitor PE 0.022 μF 20% 250V	19701	C280AE/P22K	234079-000
C239	Capacitor Cer 0.01 μF 100V	32897	805-000X5V0103Z	224119-000
C243*	Capacitor Mica 39 pF 300V	20307	DM5-EC390J	205044-000
C243*	Capacitor Mica 75 pF 5% 300V	20307	DM5-EC750J	205043-000
C243*	Capacitor Mica 56 pF 5% 300V	20307	DM5-EC560J	205031-000
C243*	Capacitor Mica 130 pF 5% 100V	20307	DM5-FA131J	205011-000
C243*	Capacitor Mica 150 pF 5% 100V	20307	DM5-FA151J	205009-000
C243*	Capacitor Mica 100 pF 5% 300V	20307	DM5-FC101J	205006-000
CR201	Diode 1N914	01295	1N914	530058-000
CR202	Diode Zener 1N5240B 10V	04713	1N5240B	530077-000
CR203	Diode 1N914	01295	1N914	530058-000
CR204	Diode 1N914	01295	1N914	530058-000
CR205	Diode S/F 530058 (4)	04901	BEC	530131-000
CR206	Diode S/F 530058 (4)	04901	BEC	530131-000
CR207	Diode S/F 530058 (4)	04901	BEC	530131-000
CR208	Diode S/F 530058 (4)	04901	BEC	530131-000
CR209	Diode 1N914	01295	1N914	530058-000
CR210	Diode 1N914	01295	1N914	530058-000
CR211	Diode 1N914	01295	1N914	530058-000
CR212	Diode 1N914	01295	1N914	530058-000
L202	Inductor 2.2 mH	00213	WEE-2200	400141-000
L203	Inductor 2.2 mH	00213	WEE-2200	400141-000
L204	Inductor 2.2 mH	00213	WEE-2200	400141-000
Q201	Transistor FET 2N5949 N-Channel	04713	2N5949	528019-000
Q202	Transistor FET 2N5949 N-Channel	04713	2N5949	528019-000
Q203	Transistor JFET 2N5953	04901	BEC	528145-000
Q204	Transistor NPN 2N5088	04713	2N5088	528047-000
Q205	Transistor 40673 S/F 528054 Blue	04901	BEC	528119-000
Q206	Transistor NPN 2N2219	04713	2N2219	528014-000
Q207	Transistor 40673 S/F 528054 Blue	04901	BEC	528119-000
Q208	Transistor PNP 2N3905	04713	2N3905	528025-000
Q209	Transistor FET 3N161	01295	3N161	528132-000
R201	Resistor MF 1.21k ohm 1%	---	RN550-1211-F	341308-000
R202	Resistor Var 2k ohm 10% 1W	91637	*784	311264-000
R203	Resistor MF 8.25k ohm 1%	---	RN550-8251-F	341388-000
R204	Resistor MF 4.32k ohm 1%	---	RN550-4321-F	341361-000
R205	Resistor MF 33.2k ohm 1%	---	RN550-3322-F	341450-000
R206	Resistor Comp 100k ohm 5%	01121	EB	344500-000
R207	Resistor MF 100k ohm 1%	---	RN550-1003-F	341500-000
R208	Resistor Comp 12k ohm 5%	01121	EB	344408-000
R209	Resistor Comp 6.8k ohm 5%	01121	EB	344380-000
R210	Resistor Comp 560k ohm 5%	01121	EB	344572-000
R211	Resistor Comp 33 ohm 5%	01121	EB	344150-000
R212	Resistor Comp 1.0k ohm 5%	01121	EB	344300-000
R213	Resistor MF 10.0 ohm 1%	---	RN550-10R0-F	341100-000
R214	Resistor Comp 150k ohm 5%	01121	EB	344517-000
R215	Resistor Comp 100k ohm 5%	01121	EB	344500-000
R216	Resistor Comp 2.7k ohm 5%	01121	EB	344341-000
R217	Resistor Comp 1.0k ohm 5%	01121	EB	344300-000
R218	Resistor MF 590 ohm 1%	---	RN550-5900-F	341274-000
R219	Resistor Comp 6.2k ohm 5%	01121	EB	344376-000
R220	Resistor Comp 2.7k ohm 5%	01121	EB	344357-000
R221	Resistor Comp 120k ohm 5%	01121	EB	344508-000
R222	Resistor Comp 47k ohm 5%	01121	EB	344465-000
R223	Resistor Comp 2.2M ohm 5%	01121	EB	344633-000
R224	Resistor Comp 510 ohm 5%	01121	EB	344268-000
R226	Resistor Comp 270 ohm 5%	01121	EB	344241-000
R227	Resistor Comp 47 ohm 5%	01121	EB	344165-000
R228	Resistor Comp 56 ohm 5%	01121	EB	344172-000
R229	Resistor Comp 47k ohm 5%	01121	EB	344465-000
R230	Resistor Comp 2.4k ohm 5%	01121	EB	344337-000
R231	Resistor Comp 1.5k ohm 5%	01121	EB	344317-000
R232	Resistor Comp 100 ohm 5%	01121	EB	344200-000
R233	Resistor Comp 12k ohm 5%	01121	EB	344408-000
R234	Resistor MF 2.67k ohm 1%	---	RN550-2671-F	341341-000
R235	Resistor MF 49.9 ohm 1%	---	RN550-49R9-F	341167-000
R236	Resistor Comp 2.0k ohm 5%	01121	EB	344329-000
R237	Resistor Comp 2.7k ohm 5%	01121	EB	344341-000
R238	Resistor MF 5.23k ohm 1%	19701	5043 (RN60D)	325396-000
R239	Resistor MF 5.23k ohm 1%	19701	5043 (RN60D)	325396-000
R240	Resistor Comp 10M ohm 5%	01121	EB	344700-000
R241	Resistor MF 5.23k ohm 1%	19701	5043 (RN60D)	325396-000
R242	Resistor Var 100 ohm 10% 1W	32997	3005P-1-101	311338-000
R243	Resistor MF 5.23k ohm 1%	19701	5043 (RN60D)	325396-000
R244	Resistor MF 10.0k ohm 1%	---	RN550-1002-F	341400-000
R245	Resistor Comp 47k ohm 5%	01121	EB	344465-000

Replaceable Parts List for Oscillator Amplifier Board Assembly PL 072022-000

Reference Symbol	Description	Mfr.	Mfr's Part No.	BEC Part No.
R246	Resistor MF 100 ohm 1%	---	RN55D-1000-F	341200-000
R247	Resistor MF 10.0k ohm 1%	---	RN55D-1002-F	341400-000
RT201	Thermistor 50 ohm 10%	00241	CB15L1	325011-000
T201	Phase Sens. Det Transformer Assembly	04901	BEC	062011-000
XA201	Socket IC 8 Pin	06776	ICN-083-S3-G	473041-000
XQ205	Socket Transistor 4 Pin	17117	7004-265-5	473051-000
XQ207	Socket Transistor 4 Pin	17117	7004-265-5	473051-000

Replaceable Parts List for Oscillator Amplifier Board Assembly PL 072022-000

Reference Symbol	Description	Mfr.	Mfr's Part No.	BEC Part No.
Y201	Crystal 1 MHz	21821	1 MHz ± .01%	547029-000

Replaceable Parts List for Inductance Var Unit Assembly PL 062009-000

Reference Symbol	Description	Mfr.	Mfr's Part No.	BEC Part No.
L201	Inductor Var	04901	BEC	400227-000

Replaceable Parts List for Amplifier Output Transformer Assembly PL 062010-000

Reference Symbol	Description	Mfr.	Mfr's Part No.	BEC Part No.
T202	Inductor Amp Output Transformer	04901	BEC	400228-000

Replaceable Parts List for Phase Sens. Det Transformer Assembly PL 062011-000

Reference Symbol	Description	Mfr.	Mfr's Part No.	BEC Part No.
T201	Inductor Phase Sensor Det. Transformer	04901	BEC	400229-000

Replaceable Parts List for Switch Assembly PL 062013-030

Reference Symbol	Description	Mfr.	Mfr's Part No.	BEC Part No.
S403	Switch Rotary	81840	Series 208	466214-000

Replaceable Parts List for Oscillator Transformer Assembly PL 072006-030

Reference Symbol	Description	Mfr.	Mfr's Part No.	BEC Part No.
C401	Capacitor Mica 560 pF 1% 300V	20307	DM15-561F	200091-000
P402C	Banana Plug with Stud 6/32 x 3/4	83330	416	477178-000
P402D	Banana Plug with Stud 6/32 x 3/4	83330	416	477178-000

S E C T I O N VI  
SCHEMATIC DIAGRAMS

TABLE OF CONTENTS

Figure	Page
6-1 Troubleshooting Block Diagram (D830716A) .....	6-3
6-2 Troubleshooting Schematic Diagram (E830715B) .....	6-5
6-3 Master P.C. Board Schematic Diagram (E830651Z, Sheet 1 of 3) .....	6-7
6-4 Oscillator-Amplifier Schematic Diagram (D830651Y, Sheet 2 of 3) ..	6-9

www.valuetronics.com

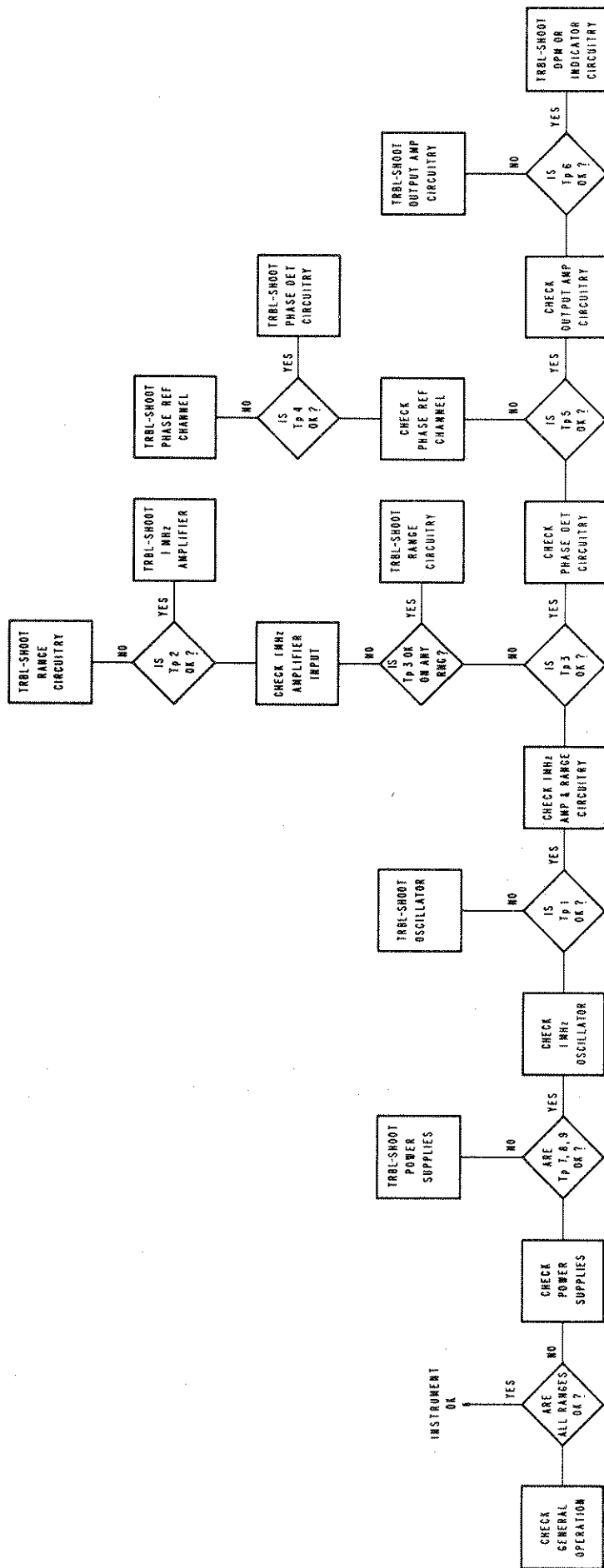
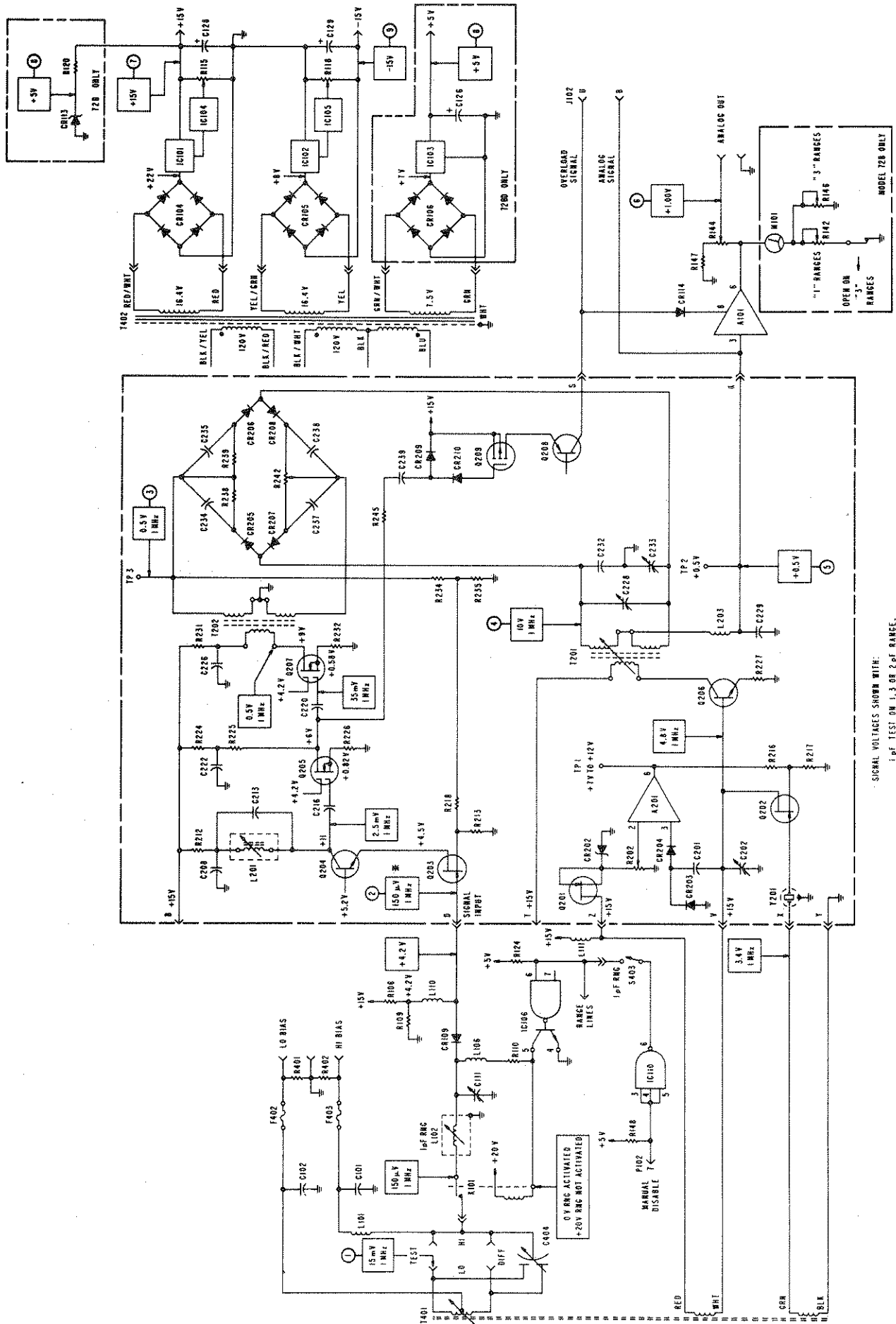

Figure 6-1.  
 Troubleshooting Block Diagram  
 (D830716A)  
 6-3/6-4

1  
2  
3  
4  
5  
6  
7  
8  
9  
10  
11  
12  
13  
14  
15  
16  
17  
18  
19  
20  
21  
22  
23  
24  
25  
26  
27  
28  
29  
30  
31  
32  
33  
34  
35  
36  
37  
38  
39  
40  
41  
42  
43  
44  
45  
46  
47  
48  
49  
50  
51  
52  
53  
54  
55  
56  
57  
58  
59  
60  
61  
62  
63  
64  
65  
66  
67  
68  
69  
70  
71  
72  
73  
74  
75  
76  
77  
78  
79  
80  
81  
82  
83  
84  
85  
86  
87  
88  
89  
90  
91  
92  
93  
94  
95  
96  
97  
98  
99  
100



SIGNAL VOLTAGES SHOWN WITH:  
 1 pF TEST ON 1.3 OR 2.5 RANGE.  
 10 pF TEST ON 10, 30 OR 200 pF RANGE.  
 100 pF TEST ON 100, 300 OR 200 pF RANGE.  
 1000 pF TEST ON 1000, 3000 OR 2000 pF RANGE.  
 \* TEST POINT 2 TEST 100 pF ON 10 (200 pF) RANGE.

Figure 6-2.  
 Troubleshooting Schematic Diagram  
 (E830715B)

1  
2  
3  
4  
5  
6  
7  
8  
9  
10  
11  
12  
13  
14  
15  
16  
17  
18  
19  
20  
21  
22  
23  
24  
25  
26  
27  
28  
29  
30  
31  
32  
33  
34  
35  
36  
37  
38  
39  
40  
41  
42  
43  
44  
45  
46  
47  
48  
49  
50  
51  
52  
53  
54  
55  
56  
57  
58  
59  
60  
61  
62  
63  
64  
65  
66  
67  
68  
69  
70  
71  
72  
73  
74  
75  
76  
77  
78  
79  
80  
81  
82  
83  
84  
85  
86  
87  
88  
89  
90  
91  
92  
93  
94  
95  
96  
97  
98  
99  
100