

**MODEL 5230 SERIES  
RF POWER METER / VOLTMETER  
INSTRUCTION MANUAL**

**BOONTON**

BOONTON ELECTRONICS CORPORATION ■ 25 EASTMANS ROAD ■ PARSIPPANY, NEW JERSEY 07054-0465

TELEPHONE: (973) 386-9696 ■ FAX: (973) 386-9191 ■ E-MAIL: [boonton@boonton.com](mailto:boonton@boonton.com)

---

MANUAL P/N 98202100A  
DATE 11/98

# SAFETY SUMMARY

The following general safety precautions must be observed during all phases of operation and maintenance of this instrument. Failure to comply with these precautions or with specific warnings elsewhere in this manual violates safety standards of design, manufacture, and intended use of the instruments. Boonton Electronics Corporation assumes no liability for the customer's failure to comply with these requirements.

## THE INSTRUMENT MUST BE GROUNDED.

To minimize shock hazard the instrument chassis and cabinet must be connected to an electrical ground. The instrument is equipped with a three conductor, three prong AC power cable. The power cable must either be plugged into an approved three-contact electrical outlet or used with a three-contact to a two-contact adapter with the (green) grounding wire firmly connected to an electrical ground at the power outlet.

## DO NOT OPERATE THE INSTRUMENT IN AN EXPLOSIVE ATMOSPHERE.

Do not operate the instrument in the presence of flammable gases or fumes.

## KEEP AWAY FROM LIVE CIRCUITS.

Operating personnel must not remove instrument covers. Component replacement and internal adjustments must be made by qualified maintenance personnel. Do not replace components with the power cable connected. Under certain conditions dangerous voltages may exist even though the power cable was removed; therefore, always disconnect power and discharge circuits before touching them.

## DO NOT SERVICE OR ADJUST ALONE.

Do not attempt internal service or adjustment unless another person, capable of rendering first aid and resuscitation, is present.

## DO NOT SUBSTITUTE PARTS OR MODIFY INSTRUMENT.

Do not install substitute parts or perform any unauthorized modification of the instrument. Return the instrument to Boonton Electronics for repair to ensure that the safety features are maintained.

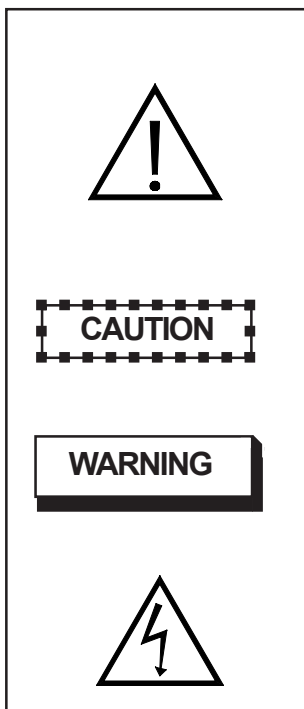

This safety requirement symbol has been adopted by the International Electrotechnical Commission, Document 66 (Central Office) 3, Paragraph 5.3, which directs that an instrument be so labeled if, for the correct use of the instrument, it is necessary to refer to the instruction manual. In this case it is recommended that reference be made to the instruction manual when connecting the instrument to the proper power source. Verify that the correct fuse is installed for the power available, and that the switch on the rear panel is set to the applicable operating voltage.

The CAUTION sign denotes a hazard. It calls attention to an operation procedure, practice, or the like, which, if not correctly performed or adhered to, could result in damage to or destruction of part or all of the equipment. Do not proceed beyond a CAUTION sign until the indicated conditions are fully understood and met.

The WARNING sign denotes a hazard. It calls attention to an operation procedure, practice, or the like, which, if not correctly performed or adhered to, could result in injury or loss of life. Do not proceed beyond a warning sign until the indicated conditions are fully understood and met.

This SAFETY REQUIREMENT symbol has been adopted by the International Electrotechnical Commission, document 66 (Central Office)3, Paragraph 5.3 which indicates hazardous voltage may be present in the vicinity of the marking.

# WARRANTY

Boonton Electronics Corporation (BEC) warrants its products to the original Purchaser to be free from defects in material and workmanship for a period of one year from date of shipment for instrument, and for one year from date of shipment for probes, power sensors and accessories. BEC further warrants that its instruments will perform within all current specifications under normal use and service for one year from date of shipment. These warranties do not cover active devices that have given normal service, sealed assemblies which have been opened or any item which has been repaired or altered without BEC's authorization.

BEC's warranties are limited to either the repair or replacement, at BEC's option, of any product found to be defective under the terms of these warranties.

There will be no charge for parts and labor during the warranty period. The Purchaser shall prepay shipping charges to BEC or its designated service facility and shall return the product in its original or an equivalent shipping container. BEC or its designated service facility shall pay shipping charges to return the product to the Purchaser. The Purchaser shall pay all shipping charges, duties and taxes if a product is returned to BEC from outside of the United States.

THE FOREGOING WARRANTIES ARE IN LIEU OF ALL OTHER WARRANTIES, EXPRESSED OR IMPLIED, INCLUDING, BUT NOT LIMITED TO, THE IMPLIED WARRANTIES OF MERCHANTABILITY AND FITNESS FOR A PARTICULAR PURPOSE. BEC shall not be liable to any incidental or consequential damages, as defined in Section 2-715 of the Uniform Commercial Code, in connection with the products covered by the foregoing warranties.

**BOONTON**

---

# SECTION I INTRODUCTION

## 1-1. INTRODUCTION.

The 5230 RF Power Meter Voltmeter family is a new innovation in RF measuring instruments. The functionality of two instruments, an RF power meter and a RF voltmeter have been seamlessly combined into a single instrument. The insertion of CW power or a voltmeter probe will cause the measurement channel to be automatically configured as a power meter or a voltmeter. Model 5231 has one measurement channel and Model 5232 has two. Each channel's configuration is determined solely by the type of sensor connected. Thus, the 5230 can behave as a Model 4230A RF Power Meter or as a Model 9230 RF Voltmeter or as a combination power meter and voltmeter. All of the features of both instruments are retained.

**1-2.** The INSTRUCTION MANUAL consists of the complete contents of the Model 4230A Instruction Manual and the Model 9230 Instruction Manual. Use the section which matches the type sensor in use. For operation with power sensors, refer to the Power Meter Section (Model 4230A); for operation with RF voltage probes, refer to the RF Voltmeter section (Model 9230).

**1-3.** When operating manually from the front panel menus, the choices displayed are appropriate for the sensor type in use. The built-in 0dBm, 50 MHz power reference is used with the voltmeter probe. Frequency cal factors are not used with the voltmeter function; they are used only with power sensors. The emulation mode for the HP437B and 438A Power Meters does not apply to voltmeter operation.

**1-4.** When operating remotely over the GPIB, the execution of a command which does not apply to the sensor type in use will result in a command error or a null operation. Sending the HPS or HPD emulation mode commands to a voltmeter channel returns an error.

One exception is the BN command used to set the native mode. It will not cause an error return if sent to a voltmeter channel, however, it may cause an unwanted channel configuration change. Avoid sending BN to a voltmeter channel.

**1-5.** The sensor related messages which appear in the display have the following meanings:

NO SENSOR means the 5230 does not recognize the presence of a sensor, even if one is physically plugged in.

INVALID means the 5230 can power up and read the sensor's EEPROM, but it does not recognize the data received and cannot use it to make measurements. This message will appear when a blank Data Adapter is plugged in. The sensor editor can be used to enter data into a Data Adapter from the panel menu. If the adapter is blank or contains an invalid model number, you will be asked if the data is for a voltage or power sensor.

**1-6.** The error control system will not allow power sensor data to be loaded into a voltage probe, or vice versa. If you want to re-use a data adapter for a different type sensor, it is best to re-initialize the adapter with the correct type before loading data. Old data will be lost.

# RF POWER METER SECTION

REF. MANUAL P/N 98102400A  
DATE 10/98

# **MODEL 4230A RF POWER METER INSTRUCTION MANUAL**

**BOONTON**

BOONTON ELECTRONICS

■ 25 EASTMANS ROAD ■ PARSIPPANY, NEW JERSEY 07054-0465

TELEPHONE: (973) 386-9696

■ FAX: (973) 386-9191

■ E-MAIL: [boonton@boonton.com](mailto:boonton@boonton.com)

---

MANUAL P/N 98102400A  
DATE 10/98

# TABLE OF CONTENTS

## SECTION I — GENERAL INFORMATION

| Paragraph |   | Page |
|-----------|---|------|
| 1-1       | Introduction .....                          | 1-1  |
| 1-3       | Description .....                           | 1-1  |
| 1-5       | Features .....                              | 1-1  |
| 1-6       | Power Sensors .....                         | 1-1  |
| 1-10      | Simple Instrument Setup and Operation ..... | 1-1  |
| 1-11      | Alphanumeric Displays .....                 | 1-1  |
| 1-12      | Selectable Ranging .....                    | 1-1  |
| 1-13      | Selectable Filtering .....                  | 1-1  |
| 1-14      | Zeroing .....                               | 1-2  |
| 1-15      | Built-In Precision Calibration .....        | 1-2  |
| 1-16      | Chart Recorder Output .....                 | 1-2  |
| 1-17      | Optional Interface .....                    | 1-2  |
| 1-18      | Accessories .....                           | 1-2  |
| 1-20      | Options .....                               | 1-2  |
| 1-21      | Option -01, Rear Input .....                | 1-2  |
| 1-22      | Option -02, Rear Calibrator .....           | 1-2  |
| 1-23      | Option -03, RS-232 .....                    | 1-2  |
| 1-24      | Option -30, Extended Warranty .....         | 1-2  |
| 1-25      | Specifications .....                        | 1-2  |

## SECTION II — INSTALLATION

|      |                          |     |
|------|--------------------------|-----|
| 2-1  | Introduction .....       | 2-1 |
| 2-2  | Unpacking .....          | 2-1 |
| 2-3  | Mounting .....           | 2-1 |
| 2-4  | Power Requirements ..... | 2-1 |
| 2-5  | Connections .....        | 2-1 |
| 2-6  | Sensor .....             | 2-1 |
| 2-7  | Recorder.....            | 2-2 |
| 2-8  | GPIB .....               | 2-2 |
| 2-9  | RS-232 .....             | 2-2 |
| 2-10 | Preliminary Check.....   | 2-2 |

## SECTION III — OPERATION

|       |   |      |
|-------|---|------|
| 3-1   | Introduction .....                                  | 3-1  |
| 3-3   | Operating Controls, Indicators and Connectors ..... | 3-1  |
| 3-5   | Operating the Instrument .....                      | 3-1  |
| 3-7   | Measurement Display .....                           | 3-1  |
| 3-9   | Menu Structure .....                                | 3-1  |
| 3-13  | Menu Key .....                                      | 3-7  |
| 3-16  | Channel Menu .....                                  | 3-7  |
| 3-18  | Setup Menu .....                                    | 3-7  |
| 3-20  | Programming Interfaces .....                        | 3-11 |
| 3-21a | IEEE Menu .....                                     | 3-11 |
| 3-21b | RS-232 Menu .....                                   | 3-11 |
| 3-22  | Diagnostics Menu .....                              | 3-13 |
| 3-23  | Sensor Key .....                                    | 3-13 |
| 3-31  | Edit Data Menu .....                                | 3-15 |
| 3-32  | Linearity Factors .....                             | 3-15 |
| 3-33  | FREQUENCY Calibration Factors .....                 | 3-16 |

|      |                     |      |
|------|---------------------|------|
| 3-36 | Save .....          | 3-16 |
| 3-37 | Freq Key .....      | 3-16 |
| 3-40 | Avg Key .....       | 3-16 |
| 3-43 | Zero/Cal Key .....  | 3-16 |
| 3-48 | Ref Level Key ..... | 3-18 |

## SECTION IV — APPLICATION NOTES

|      |  |      |
|------|--|------|
| 4-1  | Introduction .....                                 | 4-1  |
| 4-3  | Sensor Calibration .....                           | 4-1  |
| 4-4  | General.....                                       | 4-1  |
| 4-5  | 14-Point Linearity Data .....                      | 4-1  |
| 4-7  | High Frequency Calibration Points .....            | 4-1  |
| 4-9  | Zeroing .....                                      | 4-1  |
| 4-16 | Dynamic Range .....                                | 4-3  |
| 4-18 | Filtering .....                                    | 4-3  |
| 4-22 | Noise .....  | 4-4  |
| 4-23 | Noise Reduction .....                              | 4-4  |
| 4-25 | Error Computation .....                            | 4-5  |
| 4-27 | Noise Error Examples .....                         | 4-5  |
| 4-28 | Integration of Power .....                         | 4-5  |
| 4-29 | Clearing of Filter.....                            | 4-5  |
| 4-30 | Partial Results .....                              | 4-5  |
| 4-31 | Measurement Time .....                             | 4-5  |
| 4-32 | Step Response .....                                | 4-5  |
| 4-33 | Continuous Response .....                          | 4-5  |
| 4-34 | Overhead Time .....                                | 4-5  |
| 4-36 | Digital Filter .....                               | 4-5  |
| 4-37 | Default Filter Lengths .....                       | 4-5  |
| 4-38 | Settled Measurement Time .....                     | 4-5  |
| 4-39 | Fast Mode Measurement Time .....                   | 4-5  |
| 4-40 | High Frequency Accuracy .....                      | 4-10 |
| 4-43 | Waveform Sensitivity .....                         | 4-10 |
| 4-48 | Chart Recorder Operation .....                     | 4-13 |
| 4-50 | Bar Graph Operation .....                          | 4-13 |
| 4-52 | Watts Mode .....                                   | 4-13 |
| 4-53 | dBm Mode .....                                     | 4-13 |
| 4-54 | dBr Mode .....                                     | 4-14 |
| 4-55 | Remote (GPIB) Operation .....                      | 4-14 |
| 4-56 | Introduction .....                                 | 4-14 |
| 4-58 | Local Operation .....                              | 4-14 |
| 4-59 | Remote Operation .....                             | 4-14 |
| 4-60 | Bus Address .....                                  | 4-14 |
| 4-61 | Terminating Characters .....                       | 4-14 |
| 4-62 | Listen Operation .....                             | 4-14 |
| 4-63 | Talk Operation .....                               | 4-14 |
| 4-65 | IEEE-488 Command Support .....                     | 4-14 |
| 4-66 | Number Formatting .....                            | 4-15 |
| 4-67 | String Format .....                                | 4-17 |
| 4-68 | Listen Parameter Commands .....                    | 4-17 |
| 4-70 | Listen Action Commands .....                       | 4-17 |
| 4-71 | Listen Array Commands .....                        | 4-17 |
| 4-73 | Talk Modes .....                                   | 4-18 |
| 4-77 | Talk Mode 0 (Talk Measurement Floating Point)..... | 4-18 |
| 4-78 | Talk Mode 1 (Talk Measurement With Units).....     | 4-18 |
| 4-79 | Talk Mode 2 (Talk Error) .....                     | 4-18 |



|       |  |      |
|-------|--|------|
| 4-80  | Talk Mode 3 (Talk Both Channels) .....                     | 4-18 |
| 4-81  | Talk Mode 4 (Talk Channel Status) .....                    | 4-19 |
| 4-82  | Talk Mode 5 (Talk Instrument Status) .....                 | 4-19 |
| 4-83  | Talk Mode 6 (Talk Parameter) .....                         | 4-19 |
| 4-86  | Talk Mode 7 (Talk Array).....                              | 4-19 |
| 4-87  | IEEE-488 Bus Only Commands .....                           | 4-20 |
| 4-88  | General.....   | 4-20 |
| 4-89  | Talk Mode (TM) Command .....                               | 4-20 |
| 4-90  | SI Command .....   | 4-20 |
| 4-94  | SO Command .....   | 4-21 |
| 4-98  | FI Command .....   | 4-21 |
| 4-102 | FO Command .....   | 4-21 |
| 4-107 | DF Command .....   | 4-22 |
| 4-108 | DN Command .....   | 4-22 |
| 4-109 | SM (SRQ Mask) Command .....                                | 4-22 |
| 4-110 | Measured and Triggered Operation And Settled Reading ..... | 4-22 |
| 4-111 | General.....   | 4-22 |
| 4-112 | Measure Normal (MN) .....                                  | 4-23 |
| 4-113 | Measure Filtered (MF) .....                                | 4-23 |
| 4-114 | Measure Settled (MS) .....                                 | 4-23 |
| 4-115 | Measure Fast Single (MFS) .....                            | 4-23 |
| 4-116 | Measure Fast Dual (MFD) .....                              | 4-23 |
| 4-117 | Trigger Normal (TN) .....                                  | 4-23 |
| 4-118 | Trigger Filtered (TF).....                                 | 4-23 |
| 4-119 | Trigger Settled (TS) .....                                 | 4-23 |
| 4-120 | Trigger Fast Single (TFS) .....                            | 4-23 |
| 4-121 | Trigger Fast Dual (TFD) .....                              | 4-23 |
| 4-122 | IEEE Programming Examples .....                            | 4-23 |
| 4-125 | Example 1.....   | 4-23 |
| 4-126 | Example 2.....   | 4-24 |
| 4-127 | Error Messages .....                                       | 4-24 |
| 4-129 | HP Bus Emulation .....                                     | 4-24 |
| 4-131 | Turn-on Default Conditions .....                           | 4-24 |
| 4-132 | Sending the Data Message .....                             | 4-25 |
| 4-133 | Data Output Format .....                                   | 4-24 |
| 4-134 | Sending the Require Service Message .....                  | 4-25 |
| 4-135 | Service Request Mask .....                                 | 4-25 |
| 4-136 | Sending the Service Request Mask Value .....               | 4-25 |
| 4-137 | Event Status Register .....                                | 4-25 |
| 4-138 | HP Emulation Codes .....                                   | 4-26 |
| 4-139 | Remote Operation, RS-232 Interface .....                   | 4-26 |
| 4-140 | General.....   | 4-26 |
| 4-141 | Entering the Remote Mode .....                             | 4-26 |
| 4-142 | Returning to Local Mode .....                              | 4-26 |
| 4-143 | Talk Operations .....                                      | 4-26 |

# LIST OF FIGURES

| Figures |  | Page |
|---------|--|------|
| 1-1     | Model 4230A Series RF Powermeter .....                       | vi   |
| 1-2     | Outline Dimensions .....                                     | 1-2  |
| 2-1     | Packaging Diagram .....                                      | 2-1  |
| 3-1     | Model 4230A, Front Panel Controls and Connectors .....       | 3-3  |
| 3-2     | Model 4230A, Rear Panel Controls and Connectors .....        | 3-3  |
| 3-3     | Measurement Display, Local Mode .....                        | 3-5  |
| 3-4     | Measurement Display, Remote Mode .....                       | 3-5  |
| 3-5     | Model 4230A, Command Set .....                               | 3-6  |
| 3-6     | Main Menu Display .....                                      | 3-7  |
| 3-7     | Channels Menu Display .....                                  | 3-7  |
| 3-8     | Setup Menu Display, IEEE Installed .....                     | 3-9  |
| 3-9     | Setup Menu Display, RS-232 Installed .....                   | 3-10 |
| 3-10    | IEEE Menu Display .....                                      | 3-11 |
| 3-11    | RS-232 Menu Display .....                                    | 3-12 |
| 3-12    | Diagnostics Menu Display .....                               | 3-13 |
| 3-13    | Sensor Display Menu .....                                    | 3-13 |
| 3-14    | Access Code .....  | 3-14 |
| 3-15    | Edit Data Menu Display .....                                 | 3-14 |
| 3-16    | Cal Factor Menu Display .....                                | 3-14 |
| 3-17    | Calibration Data Example .....                               | 3-16 |
| 3-18    | Save Display .....   | 3-17 |
| 3-19    | Frequency Display .....                                      | 3-17 |
| 3-20    | Averaging Time Display .....                                 | 3-17 |
| 3-21    | Zero and Calibration Display .....                           | 3-17 |
| 3-22    | Reference Level Display .....                                | 3-17 |
| 4-1     | 14-Point Sensor Calibration .....                            | 4-2  |
| 4-2     | Diode Sensor Decay .....                                     | 4-2  |
| 4-3     | Thermal Sensor Decay .....                                   | 4-3  |
| 4-4     | Extended Hold Range Mode .....                               | 4-4  |
| 4-5     | Noise Reduction .....  | 4-6  |
| 4-6     | Typical Error Band Specifications .....                      | 4-7  |
| 4-7     | Probability of Falling within an Error Band .....            | 4-7  |
| 4-8     | Confidence Curves, 51013 Sensor with 2.8 Second Filter ..... | 4-8  |
| 4-9     | Confidence Curves, 51013 Sensor with 10 Second Filter .....  | 4-9  |
| 4-10    | Integration of Power .....                                   | 4-10 |
| 4-11    | Fast Mode Sampling Rate .....                                | 4-11 |
| 4-12    | Mismatch Uncertainties Chart .....                           | 4-12 |
| 4-13    | Error Due to AM Modulation (51013 Diode Sensor) .....        | 4-13 |

# LIST OF TABLES

| Table |  | Page |
|-------|--|------|
| 1-1   | Performance Specifications .....                     | 1-3  |
| 3-1   | Operating Controls, Indicators, and Connectors ..... | 3-1  |
| 3-2   | Channel Menu Functions .....                         | 3-8  |
| 3-3   | Setup Menu Functions .....                           | 3-10 |
| 3-4   | IEEE Menu Functions .....                            | 3-11 |
| 3-5   | RS-232 Menu Functions .....                          | 3-12 |
| 3-6   | Diagnostics Menu Functions .....                     | 3-13 |
| 3-7   | Edit Data Menu Functions .....                       | 3-15 |
| 3-8   | Sensor Calibration Menu Functions .....              | 3-16 |
| 3-9   | Reference Level Menu Functions .....                 | 3-18 |
| 4-1   | Listen Parameter Commands .....                      | 4-15 |
| 4-2   | Listen Action Commands .....                         | 4-16 |
| 4-3   | Listen Array Parameter Commands.....                 | 4-17 |
| 4-4   | Talk Array Commands .....                            | 4-17 |
| 4-5   | Talk Modes .....                                     | 4-17 |
| 4-6   | Error Messages .....                                 | 4-20 |
| 4-7   | SRQ Masks .....                                      | 4-22 |
| 4-8   | Status Byte and Service Request Mask.....            | 4-25 |
| 4-9   | Event Status Register.....                           | 4-25 |
| 4-10  | HP 437B Emulation GPIB Commands .....                | 4-27 |
| 4-11  | HP 438A Emulation GPIB Commands .....                | 4-30 |
| 4-12  | Boonton 4230A GPIB Commands .....                    | 4-32 |

# SECTION I

## GENERAL INFORMATION

### 1-1. INTRODUCTION.

**1-2.** This instruction manual provides general information, installation and operating instructions, and application notes for the Model 4230A Series of RF power meters. This series includes Model 4231A with a single measurement channel and Model 4232A with two measurement channels. The terms Model 4230A and 4230A used throughout this publication refer to both models unless otherwise noted. See Figures 1-1 and 1-2.

### 1-3. DESCRIPTION.

**1-4.** The Model 4230A Series is a DSP (digital signal processor) based family of single or dual channel, solid state RF power meters. They are capable of measuring RF power levels from -70 dBm to +44 dBm. The RF frequency range and power level range are sensor dependent. Boonton 51000 series sensors provide measurement capabilities for frequencies from 10 kHz to 100 GHz.

### 1-5. FEATURES.

**1-6. Power Sensors.** A wide range of diode and thermocouple power sensors for both coaxial and waveguide applications are available for use with the Model 4230A. Sensor data adapters are supplied with the Model 4230A, however, the power sensor must be ordered separately.

**1-7.** Diode sensors measure the voltage across a precision resistor, using specially selected diodes. Detection is square law (true RMS) over approximately the lower two-thirds of the sensor's dynamic range, and peak detecting over the upper portion. Because the instrument is calibrated for sine waves over the entire range, measurements at the top one-third of the sensor's dynamic range are valid only for non-modulated signals. In the RMS region, linearity is excellent, and any signal type can be measured. The diode range has been extended into the peak detecting region with the use of real time shaping for the diode curve. When coupled with the high sensitivity of the diode, such shaping allows a dynamic range of 90 dB. Diode sensors are rugged and have an overload headroom of more than 5 dB for continuous signals. The dynamic range in the RMS region can be extended further through use of an external attenuator.

**1-8.** Thermal sensors measure the voltage developed across a dissimilar metal junction caused by the thermal gradient generated by the RF power being measured. Because these sensors are heat detecting, they provide true RMS response over their entire range. Very high peak powers (15 to 30 watts)

can be accommodated for very short duty cycles and still provide valid results. The dynamic range is 50 dB. Thermal sensors are not as sensitive as diode sensors.

**1-9.** The sensor data adapter contains non-volatile memory for storage of the calibration data. In addition, calibration data for up to four sensors can be stored in the instrument's non-volatile memory. The user can enter both the linearity and high frequency sensor calibration correction data which are supplied with each sensor. For sensors ordered with the Model 4230A, the calibration data is loaded into the sensor data adapter prior to shipment. When the frequency of the RF signal to be measured by one of these sensors is entered, the instrument looks up the appropriate calibration factors, interpolates as necessary, and automatically applies the correction to the measured value. Calibration factors for sensors ordered with the instrument are stored in the plastic pouch attached to the inside of the instrument's top cover.

**1-10. Simple Instrument Setup and Operation.** In the operating mode the functions: Frequency, Averaging Time, Reference Level, Zeroing/Calibration are selected with a single keystroke. Values for these parameters are displayed and can be adjusted by using the arrow and enter keys. Additional operating parameters can be modified through the menu driven structure accessible via the <Menu> and <Sensor> keys.

**1-11. Alphanumeric Display.** The alphanumeric LCD provides clear, unambiguous readouts of the instrument's setup and measurement values. Simultaneous display of both channels is available in dual channel mode. A bar graph provides a display of the channel's measured value for nulling and peaking applications.

**1-12. Selectable Ranging.** Any of seven measurement ranges, or autoranging, can be selected during instrument setup. The selection will be held until it is changed, or until the instrument is turned off. When measuring signals with levels that fall within a narrow range, selecting one specific instrument range may reduce measurement time. Autoranging is useful if the RF signal level is unknown, or if RF signals with widely varying levels are to be measured.

**1-13. Selectable Filtering.** Measurement speed and display stability can be optimized through the use of selectable filtering. Filter times can be adjusted up to 20 seconds maximum in 50 millisecond increments.

**1-14. Zeroing.** Automatic zeroing (nulling of offsets for the

Section I  
General Information

sensor and input channel) is done independently on each range to eliminate zero carryovers.

**1-15. Built-In Precision Calibrator.** A built-in 50 MHz calibrator provides an accurate, stable, and convenient power source for calibration of the instrument to specified tolerances. The calibrator may be toggled on or off from the Setup menu. The connector is normally mounted for front panel access, however option-02 changes this to rear panel access.

**1-16. Chart Recorder Output.** A 0 to 10 volt dc output, proportional to the measurement values, is available for application to a chart recorder.

**1-17. Optional Interface.** A RS-232 option enables full service remote control of the Model 4230A. All instrument controls and values, except power on and off, are accessible to a bus controller in the remote operating mode.

**1-18. ACCESSORIES.**

**1-19.** A sensor data adapter, Model 95109001A, for each installed channel and an AC line cord are supplied with each instrument. One or more Boonton 51000 series power sensors are required. The power sensors are not supplied as part of the instrument, but must be ordered separately. A five-foot power sensor cable, Model 41-2A, is supplied with each sensor ordered. Additional available accessories include the following:

a. Model 41-2A/10 Sensor/Probe Interconnecting Cable (10 ft)

b. Model 41-2A/20 Sensor/Probe Interconnecting Cable (20 ft)

c. Model 41-2A/50 Sensor/Probe Interconnecting Cable (50 ft)

d. Model 41-2A/100 Sensor/Probe Interconnecting Cable (100 ft)

e. Model 95004701A F/F Adapter, 41-2A (for connecting Model 41-2A cables end to end)

f. Model 95004901A Bulkhead Connector F/F, 41-2A (for connecting Model 41-2A cables end to end)

g. Model 95403001A Rack Mounting Kit

h. Model 95109001A Additional Sensor Data Adapters

**1-20. OPTIONS.**

**1-21. Option-01.** Input connectors moved to rear panel.

**1-22. Option-02.** Calibrator type N connector moved to rear panel.

**1-23. Option-03.** Replaces the IEEE-488 Interface with a RS-232 Interface. The baud rate, data size, stop and parity bits are programmable.

**1-24. Option-30.** Warranty extended to 3 years.

**1-25. SPECIFICATIONS.** Performance specifications of the Model 4230A are listed in Table 1-1.

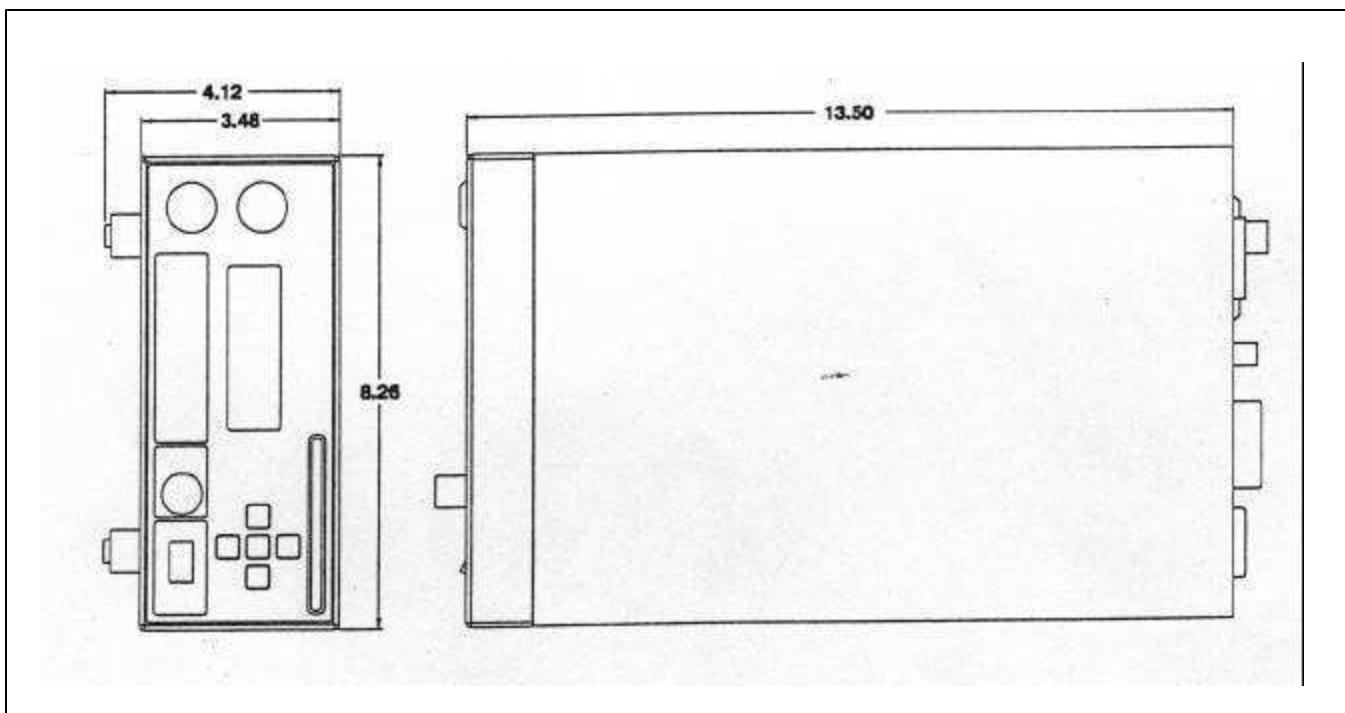

Figure 1-2. Outline Dimensions.

TABLE 1-1. PERFORMANCE SPECIFICATIONS

| Parameter                   | Specification   |
|-----------------------------|---|
| Frequency Range             | 10 kHz to 100 GHz, sensor dependent   |
| Power Range                 | -70 dBm to +44 dBm, sensor dependent  |
| Power Sensors               | Accepts sensor data adapter and is compatible with all Boonton diode and thermal sensors  |
| Dynamic Range               | Up to 90 dB with diode sensors; up to 50 dB with thermal sensors  |
| Inputs                      | Front or Rear panel sensor connector; rear panel IEEE-488 connector or optional RS-232 connector  |
| Outputs                     | Front panel or optional Rear panel PWR REF connector, 50 MHz, 0 dBm; rear panel recorder BNC connector, 9.06 kilohm impedance, 0 to 10 volts into 1 megohm (may be operated into 1 kilohm for 1V fs).                           |
| Display                     | Menu-driven 20 character x 4 line LCD   |
| Display Units               | MW, kW, W, mW, $\mu$ W, nW, dBm, dBr, %   |
| Display Resolution          | 0.001 (db,dBm, dBr) or 5 digits (nW, mW and W)  |
| Display Offset              | -99.99 dB to +99.99 dB in 0.01 dB steps   |
| Alarm                       | Individual high and low limit thresholds, -99.99 dB to +99.99 dB  |
| Peak Power Mode             | Programmable duty cycle from 0.01 to 100.00% in 0.01 steps  |
| Ranging                     | Autoranging or manual (7 ranges)  |
| Filtering                   | Filter times to 20.00 seconds in 0.05 second increments   |
| Zeroing                     | Automatic function; calculates, stores, and applies zero corrections to each range  |
| High Frequency Cal Factors  | +3 dB to -3 dB in 0.01 dB steps; cal factors for up to four power sensors with up to 60 frequencies each may be stored in the instrument's non-volatile memory; cal factors also stored in sensor data adapter                  |
| Reference Level             | -99.99 dB to +99.99 dB in 0.01 dB steps for dBr measurements  |
| Power Reference:            |   |
| Frequency                   | 50 MHz $\pm$ 1.5%   |
| Output Level                | 0 dBm   |
| Level Accuracy              | $\pm$ 0.7% ( $\pm$ 0.03 dB) (23 degrees C) for 90 days; $\pm$ 0.9% ( $\pm$ 0.04 dB) RSS, $\pm$ 1.2% ( $\pm$ 0.05 dB) worst case (0 to 55 degrees C) for 1 year  |
| Source Impedance            | 50 $\pm$ 1 ohm  |
| VSWR                        | < 1.05  |
| Harmonic Output             | < -50 dBc   |
| Measurement Accuracy        | Sum of following uncertainties (errors are $\pm$ worst case): instrument uncertainty, noise/signal percentage, power reference uncertainty, sensor shaping, temperature drift, mismatch, and high frequency calibration factors |
| Instrument Uncertainty      | .002% at full scale   |
| Noise/signal Percentage     | Refer to Power Sensor Manual, Table 2-1   |
| Power Reference Uncertainty | Refer to Table 1-1 Power Reference: Level Accuracy and for Waveguide sensors, refer to Power Sensor Manual, Table 2-2 Note 2  |
| Sensor Shaping              | Refer to Power Sensor Manual, Tables 3-1 and 3-2  |
| Temperature Drift           | Refer to Power Sensor Manual, Table 2-1   |
| Power Requirements          | 100, 120, 220, or 240 VAC ( $\pm$ 10%), 50-60 Hz or 400 Hz, 15 VA maximum   |
| Ventilation Requirements    | 1 1/2" clearance after installation, top, side, rear  |
| Temperature                 |   |
| Operating                   | 0 to 55°C   |
| Non-operating               | -40 - +75°C   |

**TABLE 1-1. PERFORMANCE SPECIFICATIONS (CONT.)**

| <b>Parameter</b>      | <b>Specification</b>   |
|-----------------------|--|
| Altitude<br>Operating | 10,000 ft.   |
| CE Mark:              | Declares conformity to European Community (EC) Council Directives:<br>89/336/EEC//93/68/EEC, 73/23/EEC//93/68/<br>EEC & Standards: EN61326-1, EN55022, EN61000-4/ -2,3,4,5,6,11, ENG1010-1 |
| Humidity              | 95% non-condensing   |
| Weight                | 7 lb (3.2 kg)  |
| Dimensions            | 8.26 in. (21.0 cm) wide 3.48 in. (8.9 cm) high, 13.5 in (34.3 cm) deep   |

## SECTION II INSTALLATION

### 2-1. INTRODUCTION.

This section contains the installation instructions for the Model 4230A Series RF Power Meter. It includes unpacking, mounting, power connections, cable connections and preliminary checkout procedures.

**2-2. UNPACKING.** The instrument is shipped complete and ready to use upon receipt. Unpack the instrument from its shipping container and inspect it for damage that may have occurred during shipment. Refer to figure 2-1.

#### NOTE

Save the packing material and container for possible use in re-shipment of the instrument.

**2-3. MOUNTING.** For bench use, choose a clean, dry and uncluttered surface. For rack mounting, an accessory kit is available which contains the necessary parts for mounting a single half-width Model 4230A or two side-by-side half-width Model 4230A's (or a compatible product) in a single 19 inch rack.

**2-4. POWER REQUIREMENTS.** The Model 4230A has a tapped transformer and a power entry module containing a line voltage selector switch and two fuses. Operation is permitted from 100, 120, 220 and 240 Volt  $\pm 10\%$ , 50 to 60 Hz, single phase AC power supplies.



Always make certain that the setting of the line voltage selector switch most nearly corresponds to the voltage of the AC power source, and that fuses of the correct rating according to the chart just above the power entry module, are installed.

To change the line voltage selector switch or the fuses, follow this procedure:

1. REMOVE the power cable from the power entry module.
2. To open the power entry module, place a small screwdriver or coin in the slot at the top of the module and gently pry the cover open.
3. Using a small screwdriver gently pry the voltage selector cylinder from the module. Turn the cylinder

so that when it is re-inserted into the module, the desired voltage will appear in the small window in the cover.

4. To remove the fuses, move the fuseholder tabs in the direction of the arrow and pull the holder out. Place a new fuse in the holder and put it back in the slot, restoring the tab to its original position.

5. After all changes are completed, close the cover. Make sure the alignment of the selector cylinder and window is correct and that the cover snaps into place.

| VOLTAGE  | FUSE   | IEC TYPE |
|----------|--------|----------|
| 100/120V | 0.315A | T        |
| 220/240V | 0.160A | T        |

**2-5. CONNECTIONS.** An AC power cable is supplied with the instrument and a standard interconnecting cable or cable/adaptor combination is supplied with each RF Sensor. Longer RF Sensor cables are available as accessories. All other cables required must be supplied by the user.

**2-6. Sensor.** Connect the RF Sensor that is to be used for measurement to the cable or Data Adapter-Cable combo supplied with the sensor. If the Data Adapter is a separate item, also connect the cable to the adapter. Make sure that the serial number on the Data Adapter matches the serial number of the RF Sensor. Insert the 10-pin adapter plug into one of the two sensor inputs. For Model 4231, only Sensor input number 1 is active.

**2-7. Recorder.** A data recorder or other similar device can be connected to the Recorder BNC connector on the rear panel. The output is a DC voltage proportional to the Channel 1 display value. The voltage range is 0 to 10 volts with an output impedance of approximately 9 kohms.

**2-8. GPIB.** The standard instrument is equipped with an IEEE-488 bus interface for remote operation. The connector is located on the rear panel.

**2-9. RS-232.** The optional RS-232 interface can be supplied in place of the standard IEEE-488 interface. This interface also provides remote operation using the same command strings. The DB-25 connector is located on the rear panel.



## 2-10. PRELIMINARY CHECK.

2-11. The following preliminary check verifies that the Model 4230A is operational. It should be performed before the instrument is placed in service. Proceed as follows:

- a. Ensure that the voltage selector switch and fuses correspond to the AC power source voltage to be used.
- b. Connect the AC power cable to the instrument and to the power source.
- c. Connect one or two RF Sensors to the instrument as described above.
- d. Set the front panel OFF/ON power switch to the ON position..
- e. Verify that  
BOONTON ELECTRONICS  
423XA RF POWER METER  
Rev. X.XX

is momentarily displayed.

- f. Verify that the measurement display showing "CH 1" only for Model 4231 or "CH 1" and "CH 2" for Model 4232. Other data on the display will depend upon previous settings.
- g. Press the <MENU> key and select DIAGNOSTICS with the down arrow key. Press <ENTER>. Verify the following sub-menu:

```
DIAGNOSTICS
RTN
SELFTTEST <
SWITCHES
RECORDER
```

- h. Press <ENTER> to execute the selftest. The items tested are:
  1. Processor
  2. SRAM Memory
  3. EEPROM

Each test will display the OK message if it passed. When the test is completed the menu will reappear.

- i. Use the <Down Arrow> key to move the "<" cursor to SWITCHES and press <ENTER>. Press each front panel key, avoiding <MENU> until last. Each key press will result in an identifying message; <MENU> will exit the test and return to the MENU.

- j. Use the <Down Arrow> key to select RECORDER and press <ENTER>. This test will sequentially send a DC voltage in 1 volt steps to the recorder output BNC connector on the rear panel. The test will continue until <MENU> is pressed. Use a DC voltmeter to verify correct operation.

- k. Press <MENU> to return to the measurement display.

- l. Press the <Sensor> key and verify that the RF Sensor serial number(s) appear under the channel heading(s). An active channel with no sensor installed will report a table number.

- m. Press the <AVG> key and verify that the filter time and number of samples appear for each active channel.

- n. Press the <REF Level> key and verify that a reference level and mode is shown for each active channel.

- o. With each installed sensor connected to the reference output, press the <ZERO/CAL> key and select ZERO/CAL function for the active channel. Verify the ZERO/CAL operation completes successfully. Repeat this operation for the other channel if installed.

- p. For standard instruments equipped with the IEEE-488 interface, connect a GPIB controller to the Model 4230A. Verify that the instrument can be addressed to Listen at its IEEE bus address, and set to Remote. The display must show the correct status on the bottom line of the display. For message passing, the line terminators for the controller and the Model 4230A must be compatible for both Listen and Talk. Use <MAIN> <SETUP> <IEEE> to set address and terminators for the 4230A. Address the Model 4230A to Listen/Remote and send the command "?ID" or "\*IDN?" EOL. Then address the Model 4230A to Talk (controller to listen) and verify that the correct identification string is returned.

- q. For instruments equipped with the optional RS-232 interface, connect a dumb terminal or PC serial terminal to the Model 4230A. Use a null modem if the terminal is wired as DCE. For message communication to take place, the parameters of the serial connection and message strings must agree between the terminal and the Model 4230A. Use <MAIN> <SETUP> <RS-232> to set parameters for the 4230A. Send the command "?ID" or "\*IDN?" EOL and verify that the correct identification string is returned.

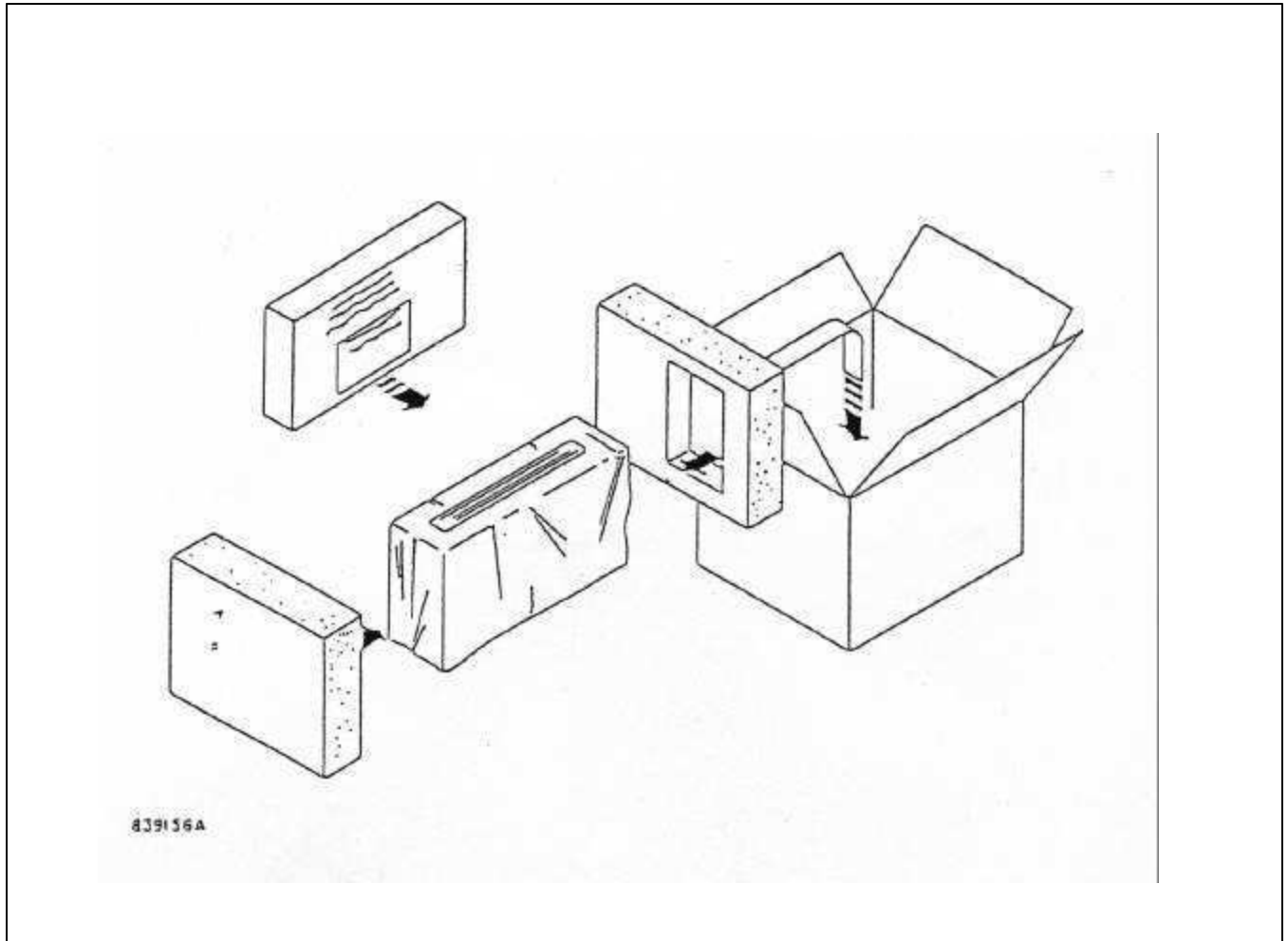

Figure 2-1. Packing and Unpacking Diagram

## SECTION III OPERATION

### 3-1. INTRODUCTION.

**3-2.** This section contains operating instructions for the Model 4230A. It is strongly recommended that the operator become familiar with all the material in this section and with the application notes in Section IV before attempting to operate the instrument; otherwise, the full capabilities of the instrument may not be realized.

### 3-3. OPERATING CONTROLS, INDICATORS, AND CONNECTORS.

**3-4.** See Figures 3-1 and 3-2 for the location of the operating controls and connectors. Refer to Table 3-1 for the function of each of these items.

### 3-5. OPERATING THE INSTRUMENT.

**3-6.** Energize the instrument by setting the POWER switch to the ON position. The instrument will perform a self test routine and initialize the operating parameters to the power-up values.

### 3-7. MEASUREMENT DISPLAY.

**3-8.** The measurement screen shown in Figure 3-3 can be configured to display one or two channels along with the corresponding bar graph. In alarm mode, the  $\wedge$  and the  $\vee$  symbols are displayed before the channel mode to indicate that the measured value is above or below the defined limits. An asterisk is displayed before the channel mode when in the manual range mode and the measured value is below the lower range limit indicating an uncalibrated measurement. The alarm indicators have precedence over the range limit display. In peak pulse mode, the  $P_K$  symbol is displayed after the measurement unit. The  $\Delta$  symbol is displayed when the measurement is associated with an offset. When the instrument is configured for remote operations over the IEEE-488 or RS-232 bus, the last line, as shown in Figure 3-4, is always used for the bus indicators.

### 3-9. MENU STRUCTURE.

**TABLE 3-1. OPERATING CONTROLS, INDICATORS, AND CONNECTORS**

| Index and Fig. No. | Nomenclature                | Function  |
|--------------------|-----------------------------|---|
| 1, 3-1             | Sensor Connector, Channel 2 | Provides the means for connecting the power sensor to channel 2 of the instrument.  |
| 2, 3-1             | Sensor Connector, Channel 1 | Provides the means for connecting the power sensor to channel 1 of the instrument.  |
| 3, 3-1             | Display                     | LCD readout of the measurements and user interface for editing of the instrument's operating parameters.  |
| 4, 3-1             | Left Arrow Key              | In entry mode, advances the cursor to the left.   |
| 5, 3-1             | Up Arrow Key                | In entry mode, advances the cursor upwards. In parameter entry mode, scrolls forward through the parameter list. In numerical entry mode, advances the value to the next higher digit.    |
| 6, 3-1             | Enter Key                   | In entry mode, initiates the procedure to change a parameter. In parameter entry mode, terminates the current command and changes the parameter to the last displayed value.              |
| 7, 3-1             | Right Arrow Key             | In entry mode, advances the cursor to the right.  |
| 8, 3-1             | Down Arrow Key              | In entry mode, advances the cursor downwards. In parameter entry mode, scrolls backwards through the parameter list. In numerical entry mode, advances the value to the next lower digit. |
| 9, 3-1             | Power Switch                | Turns the instrument off and on.  |
| 10, 3-1            | 0 dBm 50 MHz Connector      | Provides a 50 MHz, 0 dBm output for instrument calibration. When the calibrator is off, the connector serves as a 50 $\Omega$ termination to zero the instrument.                         |

**TABLE 3-1. OPERATING CONTROLS, INDICATORS, AND CONNECTORS (CONT)**

| <b>Index and Fig. No.</b> | <b>Nomenclature</b>                                 | <b>Function</b>   |
|---------------------------|---|---|
| 11, 3-1                   | <REF Level> Key                                     | Selects the reference level menu for relative measurements.   |
| 12, 3-1                   | <Zero/CAL> Key                                      | Selects the zeroing and 0 dBm reference level calibration functions.  |
| 13, 3-1                   | <AVG> Key   | Selects the filter averaging display for the measurement value.   |
| 14, 3-1                   | <FREQ> Key  | Selects the operating frequency display.  |
| 15, 3-1                   | <Sensor> Key  | Displays the serial number of the installed sensors and allows for editing of the sensor parameters.  |
| 16, 3-1                   | <Menu> Key  | Displays and allows editing of the instrument's operating parameters. Returns instrument to local mode when operating in the bus remote mode. Escapes back to measurement screen from any menu. |
| 17, 3-2                   | Power Receptacle                                    | Provides means for connecting the AC power cord to the instrument.  |
| 18, 3-2                   | Fuse  | Protects the power circuits from overload.  |
| 19, 3-2                   | Voltage Selector Switches                           | Switches the power circuits of the instrument to accommodate 100, 120, 220 or 240 volt AC power sources.  |
| 20, 3-2                   | Recorder Connector                                  | Provides a DC voltage proportional to the measured values for use by an external recorder   |
| 21, 3-2                   | GPIB Connector<br>or RS-232 Connector               | Provides means for connecting the instrument to the IEEE-488 or RS-232 bus for remote control   |
| 22, 3-2                   | Optional Location of<br>Sensor Connector, Channel 2 | Provides the means of connecting the power sensor to channel 2 of the instrument.   |
| 23, 3-2                   | Optional Location of<br>0 dBm 50 MHz Connector      | Provides 50 MHz, 0 dBm output for instrument calibration.   |
| 24, 3-2                   | Optional Location of<br>Sensor Connector, Channel 1 | Provides the means of connecting the power sensor to channel 1 of the instrument.   |

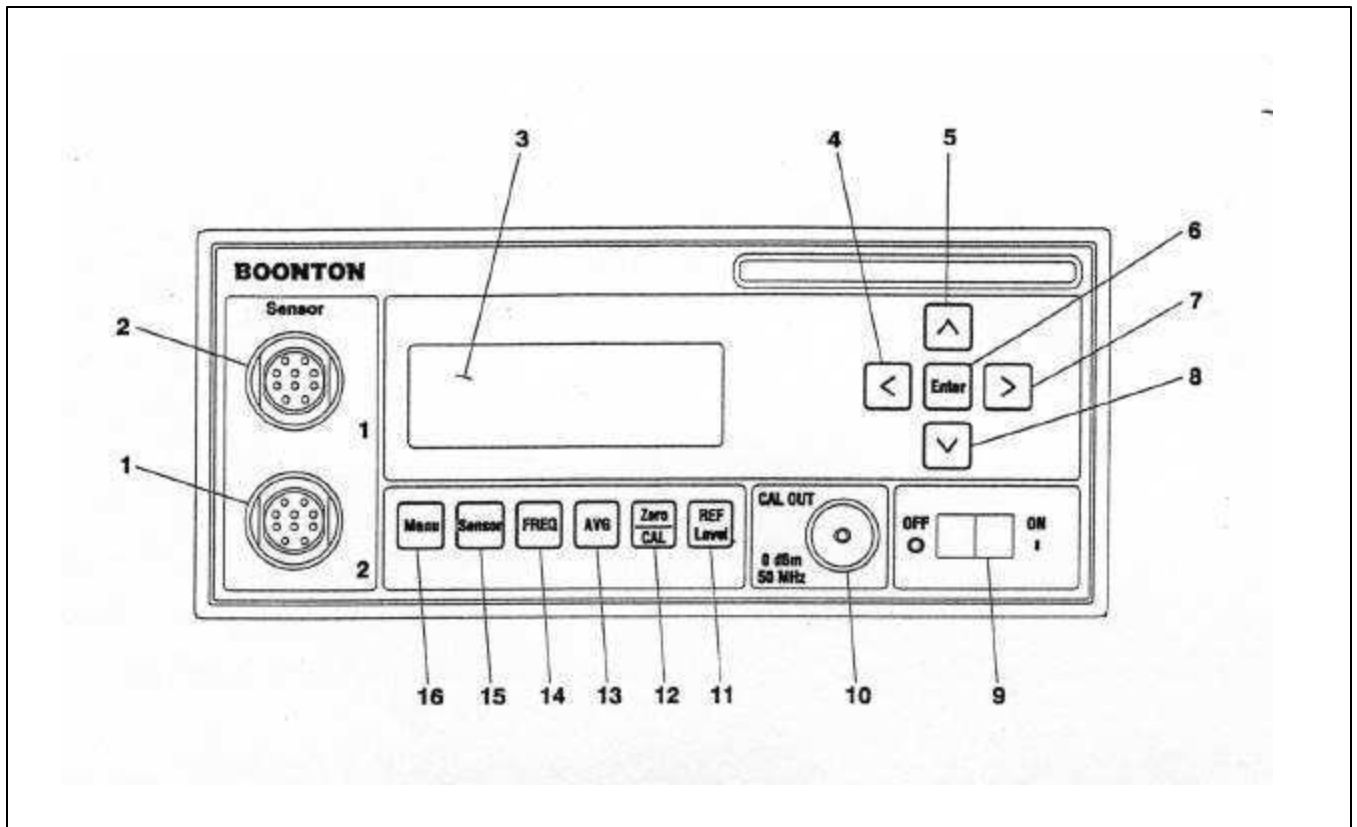

Figure 3-1. Model 4230A, Front Panel Controls and Connectors

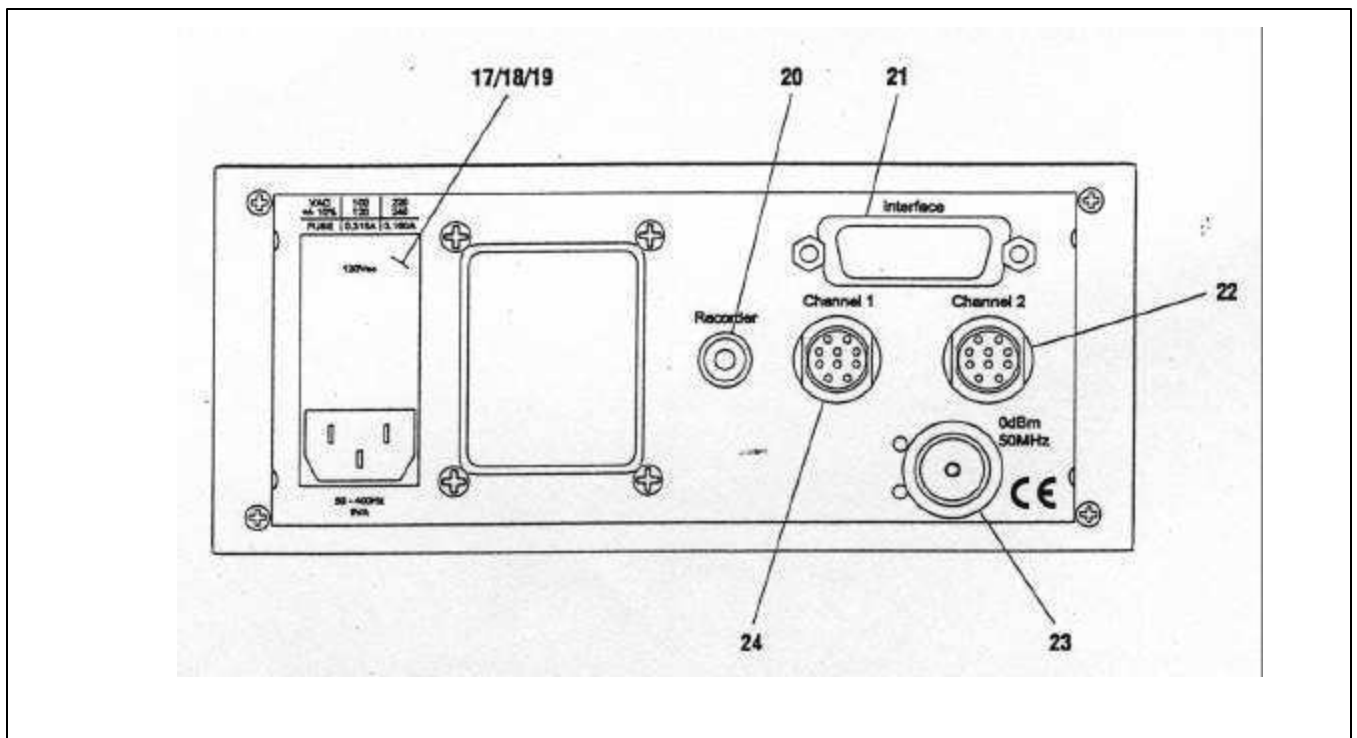

Figure 3-2. Model 4230A, Rear Panel Controls and Connectors

## Section III Operation

**3-10.** The Model 4230A can be configured for operation via the six switches on the front panel; <Menu>, <Sensor>, <FREQ>, <AVG>, <Zero/CAL> and <REF Level>. Pressing a key will bring the instrument to the next submenu. A flow chart of the instrument's command structure is shown in Figure 3-5. The <Menu> key also serves as an ESCAPE key to cancel the current operation from any point and return to the measurement screen.

**3-11.** To change a value, use the arrow keys to position the cursor to the desired parameter. Press the <Enter> key and then use the up/down arrow keys to scroll through the parameter list. When a number is to be entered, use the left/right arrow keys to position the cursor under the number that is to be changed, then use the up/down arrow keys to increment/decrement the number. Holding the up/down

arrow key will initiate repeat mode to allow rapid movement through the selections. The <Enter> key must be pressed to accept the current selection.

**3-12.** Within a submenu, the ^v indicators are displayed in the upper right portion of the display when the current screen has additional information that can be obtained by scrolling with the up/down arrow keys. Three conditions are possible:

a.^ Use the up arrow key to scroll the screen upward for additional information.

b.v Use the down arrow key to scroll the screen downward for additional information.

c.^v Use the up/down arrow keys to scroll the screen upward/downward for additional information.

**DUAL CHANNEL**

|   |   |   |   |   |   |   |   |   |   |   |   |   |   |   |   |   |  |                |   |
|---|---|---|---|---|---|---|---|---|---|---|---|---|---|---|---|---|--|----------------|---|
| L | M | M | M | M | M |   | ± | D | D | D | D | D | D | U | U | U |  | P <sub>K</sub> | Δ |
|   |   |   |   | ( | B | A | R |   | G | R | A | P | H | ) |   |   |  |                |   |
| L | M | M | M | M | M |   | ± | D | D | D | D | D | D | U | U | U |  | P <sub>K</sub> | Δ |
|   |   |   |   | ( | B | A | R |   | G | R | A | P | H | ) |   |   |  |                |   |

**SINGLE CHANNEL**

|   |   |   |   |   |   |   |   |   |   |   |   |   |   |   |   |   |  |                |   |
|---|---|---|---|---|---|---|---|---|---|---|---|---|---|---|---|---|--|----------------|---|
| L | M | M | M | M | M |   | ± | D | D | D | D | D | D | U | U | U |  | P <sub>K</sub> | Δ |
|   |   |   |   | ( | B | A | R |   | G | R | A | P | H | ) |   |   |  |                |   |
|   |   |   |   |   |   |   |   |   |   |   |   |   |   |   |   |   |  |                |   |
|   |   |   |   |   |   |   |   |   |   |   |   |   |   |   |   |   |  |                |   |

- Key:**
- O = 0 through 9 or a decimal point
  - L = ^, v, (alarm mode), \* (range hold-low)
  - MMMMM = CH1, CH2, CH1+2, CH1/2
  - UUU = nW, μW, mW, kW, MW, dBm, dBr, %

**Figure 3-3. Measurement Display, Local Mode**

|   |   |   |   |   |   |   |   |   |   |   |   |   |   |   |   |   |   |                |   |
|---|---|---|---|---|---|---|---|---|---|---|---|---|---|---|---|---|---|----------------|---|
| L | M | M | M | M | M |   | ± | D | D | D | D | D | D | U | U | U |   | P <sub>K</sub> | Δ |
|   |   |   |   | ( | B | A | R |   | G | R | A | P | H | ) |   |   |   |                |   |
| L | M | M | M | M | M |   | ± | D | D | D | D | D | D | U | U | U |   | P <sub>K</sub> | Δ |
|   | R | E | M |   |   | L | S | N |   |   | T | L | K |   |   | S | R | Q              |   |

- Key:**
- REM = Remote mode enabled
  - LSN = Listen addressed
  - TLK = Talker addressed
  - SRQ = Service request activated

**Figure 3-4. Measurement Display, Remote Mode**

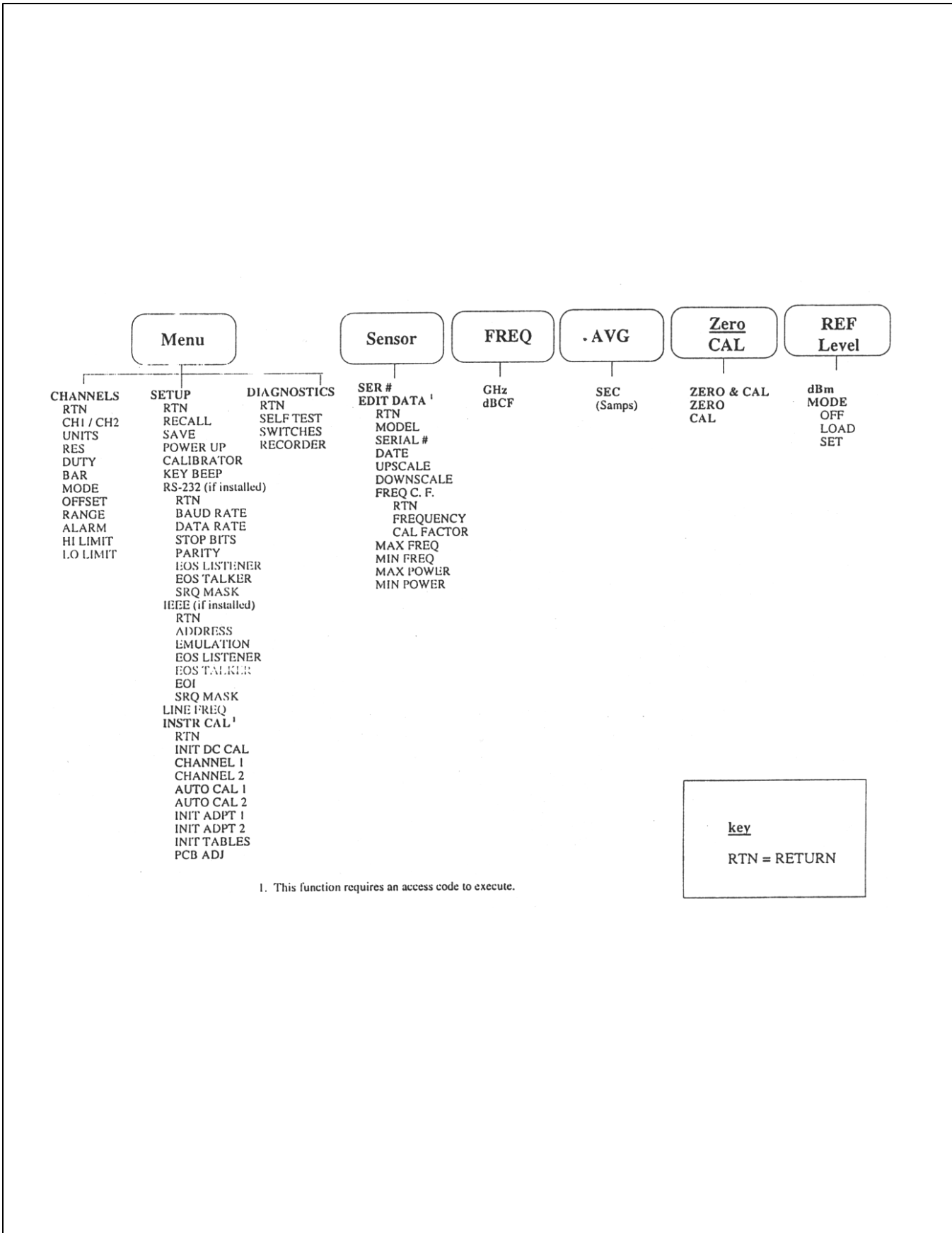

Figure 3-5. Model 4230A, Command Set



**3-13. MENU Key.**

**3-14.** The instrument's, CHANNELS, SETUP and DIAGNOSTIC commands are accessed when the <Menu> key is pressed.

**3-15.** Using the up/down arrow keys, the cursor can be positioned to select from the three submenus.

**3-16. Channel Menu.** An example of the display for the Channels menu, when two channels are installed in the Model 4230A, is shown in Figure 3-7. Although the figure shows eleven lines, the instrument can only display four at a time. Therefore, it will be necessary to use the up/down arrow keys to sequence through the commands. When viewing the commands, the instrument will retain the first line as a header and use the next three lines to scroll through the remaining commands.

**3-17.** Table 3-2 gives a description of the commands available from the Channels menu. The associated parameters, and factory default settings are also given.

**3-18. Setup Menu.** An example of the display for the Setup menu, when the Model 4230A is configured with an IEEE interface, is shown in Figure 3-8. Figure 3-9 is an example of the instrument when equipped with the RS-232 option. It will be necessary to use the up/down arrow keys to sequence through the commands since there are more than four lines of information to be displayed. When sequencing through the commands, the instrument will retain the first line as a header and use the next three lines to scroll through the command list.

|   |   |   |   |   |   |   |   |   |   |   |  |  |  |  |  |  |  |
|---|---|---|---|---|---|---|---|---|---|---|--|--|--|--|--|--|--|
|   |   |   |   |   |   |   |   |   |   |   |  |  |  |  |  |  |  |
| C | H | A | N | N | E | L | S |   |   | < |  |  |  |  |  |  |  |
| S | E | T | U | P |   |   |   |   |   |   |  |  |  |  |  |  |  |
| D | I | A | G | N | O | S | T | I | C | S |  |  |  |  |  |  |  |

**Figure 3-6. Main Menu Display**

|   |   |   |   |   |   |   |   |   |   |   |   |   |   |   |   |   |   |   |
|---|---|---|---|---|---|---|---|---|---|---|---|---|---|---|---|---|---|---|
| R | T | N |   |   |   |   | C | H | 1 |   |   | C | H | 2 |   | ∇ | ∧ |   |
| U | N | I | T | S |   | > | W | A | T | T | S |   | d | B | m |   |   |   |
| R | E | S |   |   |   |   | X | X | X | X |   |   | X | . | X | X |   |   |
| D | U | T | Y |   |   |   | 1 | 0 | 0 | . | 0 | 0 | 1 | 0 | 0 | . | 0 | 0 |
| B | A | R |   |   |   |   | O | F | F |   |   |   | O | N |   |   |   |   |
| M | O | D | E |   |   |   |   |   |   |   |   |   | C | H | 2 |   |   |   |
| O | F | F | S | E | T |   | 0 | . | 0 | 0 |   |   | 1 | 0 | . | 0 | 0 |   |
| R | A | N | G | E |   |   | A | U | T | O |   |   | 4 |   |   |   |   |   |
| A | L | A | R | M |   |   | O | N |   |   |   |   | O | F | F |   |   |   |
| H | I |   | L | M | T |   | 1 | 0 | . | 0 | 0 |   | 0 | . | 0 | 0 |   |   |
| L | O |   | L | M | T |   | 1 | . | 0 | 0 |   |   | 0 | . | 0 | 0 |   |   |

**Figure 3-7. Channels Menu Display**

**TABLE 3-2. CHANNEL MENU FUNCTIONS**

| <b>Function</b> | <b>Description</b>  | <b>Parameters</b>                                  | <b>Default</b> |
|-----------------|---|--|----------------|
| RTN             | Returns the instrument to the previous menu.  | n/a  | n/a            |
| UNITS           | Units used for measurement display.   | dBm, WATTS   | dBm            |
| RES             | Display resolution  | X.X, X.XX, X.XXX dBm or/<br>XXX, XXXX, XXXXX Watts | X.XX           |
| DUTY            | Duty cycle for pulse power applications; a value less than 100.00 enables pulse power mode.   | 0.01 to 100.00%                                    | 100.00         |
| BAR             | Enables the bar graph on the measurement display.   | ON, OFF  | ON             |
| MODE            | Sets the display mode for channel 2; only available when two channels are installed. The units for the sum and ratio modes track the units selected for Channel 2.                                | CH2, CH1+2, CH1/2,<br>OFF                          | CH2            |
| OFFSET          | Sets the offset added to the measured value.  | -99.99 to 99.99 dB                                 | 0.00           |
| RANGE           | Selects and holds the instrument's measurement range. If repetitive measurements are to be made over a narrow range of levels, selecting the appropriate instrument range may speed measurements. | Auto, 0,1,2,3,4,5,6                                | AUTO           |

**TABLE 3-2. CHANNEL COMMANDS (CONT)**

| Command | Description   | Parameters          | Default |
|---------|---|---------------------|---------|
| ALARM   | Enables alarm mode; the ∨ or ^ symbol is displayed before the channel mode designator on the measurement display to indicate when the upper or lower threshold limit is exceeded. | ON, OFF             | OFF     |
| HI LMT  | Upper threshold limit for the alarm function.   | -99.99 to 99.99 dBm | 0.00    |
| LO LMT  | Lower threshold limit for the alarm function.   | -99.99 to 99.99 dBm | 0.00    |

|   |   |   |   |   |   |   |   |   |   |   |   |  |   |   |   |   |   |   |   |   |
|---|---|---|---|---|---|---|---|---|---|---|---|--|---|---|---|---|---|---|---|---|
| R | T | N |   |   |   |   |   |   |   |   |   |  |   |   |   |   |   |   | ∨ | ^ |
| R | E | C | A | L | L |   |   |   |   | > | 1 |  |   |   |   |   |   |   |   |   |
| S | A | V | E |   |   |   |   |   |   |   | 2 |  |   |   |   |   |   |   |   |   |
| P | O | W | E | R | - | U | P |   |   |   |   |  | D | E | F | A | U | L | T |   |
| C | A | L | I | B | R | A | T | O | R |   |   |  | O | F | F |   |   |   |   |   |
| K | E | Y |   | B | E | E | P |   |   |   |   |  | O | F | F |   |   |   |   |   |
| I | E | E | E |   |   |   |   |   |   |   |   |  |   |   |   |   |   |   |   |   |
| I | N | S | T | R |   | C | A | L |   |   |   |  |   |   |   |   |   |   |   |   |

**Figure 3-8. Setup Menu Display, IEEE Installed**

|   |   |   |   |   |   |   |   |   |   |   |   |   |   |   |   |   |   |   |
|---|---|---|---|---|---|---|---|---|---|---|---|---|---|---|---|---|---|---|
| R | T | N |   |   |   |   |   |   |   |   |   |   |   |   |   |   | ∨ | ∧ |
| R | E | C | A | L | L |   |   |   |   |   | 1 |   |   |   |   |   |   |   |
| S | A | V | E |   |   |   |   |   |   | > | 2 |   |   |   |   |   |   |   |
| P | O | W | E | R | - | U | P |   |   |   |   | D | E | F | A | U | L | T |
| C | A | L | I | B | R | A | T | O | R |   |   | O | F | F |   |   |   |   |
| K | E | Y |   | B | E | E | P |   |   |   |   | O | F | F |   |   |   |   |
| R | S | - | 2 | 3 | 2 |   |   |   |   |   |   |   |   |   |   |   |   |   |
| I | N | S | T | R |   | C | A | L |   |   |   |   |   |   |   |   |   |   |

Figure 3-9. Setup Menu Display, RS-232 Installed

3-19. Table 3-3 gives a description of the commands, parameters and default settings of the Setup menu.

TABLE 3-3. SETUP MENU FUNCTIONS

| Command    | Description   | Parameters          | Default |
|------------|---|---------------------|---------|
| RTN        | Returns the instrument to the previous menu.  | n/a                 | n/a     |
| RECALL     | Recalls one of ten user defined instrument configurations or the factory setup.         | Default, 1-10       | Default |
| SAVE       | Saves the current instrument configuration to one of ten non-volatile memory locations. | 1-10                | 1       |
| POWER-UP   | Instructs the instrument to power-up to the specified configuration.                    | Default, 1, 2, 3, 4 | Default |
| CALIBRATOR | Turns on/off the internal 50 MHz 0 dBm calibrator.                                      | ON, OFF             | ON      |
| KEY BEEP   | Turns on/off the key beep.  | ON, OFF             | ON      |
| IEEE       | Brings the instrument to the IEEE menu. (if installed)                                  | see table 3-4       | n/a     |
| RS-232     | Brings the instrument to the RS-232 menu. (if installed)                                | see table 3-5       | n/a     |
| LINEFREQ   | Select line (mains) frequency.  | 50Hz, 60Hz          | n/a     |
| INSTRCAL   | Refer to Service Manual.  | n/a                 | n/a     |

**3-20. Programming Interfaces.** Either the IEEE-488 or RS-232 interface is installed, but not both. The appropriate setup menu will appear in the list.

**3-21a. IEEE Menu.** The IEEE submenu is used to configure the Model 4230A for communications over the GPIB. An example of the menu is shown in Figure 3-10 and the description of the commands, parameters and factory defaults is given in Table 3-4.

**3-21b. RS-232 Menu.** The RS-232 menu is used to configure the Model 4230A for serial communications over the RS-232 bus. An example of the submenu is shown in Figure 3-11 and an explanation of the commands, parameters and factory defaults is given in Table 3-5.

|   |   |   |   |   |   |   |   |   |   |  |   |   |   |   |  |  |   |   |
|---|---|---|---|---|---|---|---|---|---|--|---|---|---|---|--|--|---|---|
| R | T | N |   |   |   |   |   |   |   |  |   |   |   |   |  |  | ∨ | ∧ |
| A | D | D | R | E | S | S |   |   |   |  | 1 | 5 |   |   |  |  |   |   |
| E | M | U | L | A | T | I | O | N |   |  | 4 | 2 | 3 | 0 |  |  |   |   |
| E | O | S |   | L | S | T | N |   |   |  | L | F |   |   |  |  |   |   |
| E | O | S |   | T | A | L | K | E | R |  | C | R | L | F |  |  |   |   |
| E | O | I |   |   |   |   |   |   |   |  | O | F | F |   |  |  |   |   |
| S | R | Q |   | M | A | S | K |   |   |  | 0 |   |   |   |  |  |   |   |

Figure 3-10. IEEE Menu Display

TABLE 3-4. IEEE MENU FUNCTIONS (if installed)

| Command    | Description   | Parameters   | Default |
|------------|---|--|---------|
| RTN        | Returns the instrument to the previous menu.                        | n/a  | n/a     |
| ADDRESS    | GPIB address assigned to the instrument.                            | 0 to 30  | n/a     |
| EMULATION  | GPIB emulation mode.  | NONE, HP437B, HP438A   | 4230A   |
| EOS LSTN   | End of string indicator for received messages.                      | LF, CR, CRLF, NONE<br>Where:<br>LF = Line Feed<br>CR = Carriage Return<br>CRLF = Carriage Return and Line Feed | LF      |
| EOS TALKER | End of string character sent with transmitted messages.             | LF, CR, CRLF, NONE   | CRLF    |
| EOI        | Enables/disables the end or identify hardware control line.         | ON, OFF  | OFF     |
| SRQ MASK   | Service request interrupt mask. See Table 4-7 for bit descriptions. | 0 to 255<br>Where:<br>255 enables all interrupts   | 0       |

|   |   |   |   |   |   |   |   |   |   |   |   |  |  |  |   |   |   |   |
|---|---|---|---|---|---|---|---|---|---|---|---|--|--|--|---|---|---|---|
| R | T | N |   |   |   | < |   |   |   |   |   |  |  |  |   | ∨ | ∧ |   |
| B | A | U | D |   | R | A | T | E |   |   |   |  |  |  | 9 | 6 | 0 | 0 |
| D | A | T | A |   | B | I | T | S |   |   |   |  |  |  | 8 |   |   |   |
| S | T | O | P | S |   | B | I | T | S |   |   |  |  |  | 1 |   |   |   |
| P | A | R | I | T | Y |   |   |   |   |   |   |  |  |  | N | O | N | E |
| E | O | S |   | L | I | S | T | E | N | E | R |  |  |  | L | F |   |   |
| E | O | S |   | T | A | L | K | E | R |   |   |  |  |  | C | R | L | F |
| S | R | Q |   | M | A | S | K |   |   |   |   |  |  |  | 0 |   |   |   |

Figure 3-11. RS-232 Menu Display

TABLE 3-5. RS-232 MENU FUNCTIONS (if installed)

| Command    | Description   | Parameters   | Default |
|------------|---|--|---------|
| RTN        | Returns the instrument to the previous menu.                        | n/a  | n/a     |
| BAUD RATE  | Rate at which data is transferred over the bus.                     | 300, 1200, 2400, 9600<br>19200   | 9600    |
| DATA BITS  | Number of data bits in a message.                                   | 7, 8   | 8       |
| STOP BITS  | Number of stop bits in a message.                                   | 1, 2   | 1       |
| PARITY     | Parity bit mode in a message.                                       | ODD, EVEN, NONE  | NONE    |
| EOS        | End of string indicator for received messages.                      | LF, CR, CRLF, NONE   | LF      |
| LISTENER   |   | Where:<br>LF = Line Feed<br>CR = Carriage Return<br>CRLF = Carriage Return & Line Feed |         |
| EOS TALKER | End of string character sent with transmitted messages.             | LF, CR, CRLF, NONE   | CRLF    |
| SRQ MASK   | Service request interrupt mask. See Table 4-7 for bit descriptions. | 0 to 255<br>Where:<br>255 enables all interrupts                                       | 0       |

**3-22. Diagnostics Menu.** The Model 4230A can be directed to perform self-tests from the diagnostics menu. The Diagnostics menu is shown in Figure 3-12 and a description of each command is given in Table 3-6.

**3-23. SENSOR KEY.**

**3-24.** Pressing the <Sensor> key brings the instrument to the Sensor menu and facilitates viewing and editing of the power sensor's parameters. An access code is required to enter the editing mode (refer to Figure 3-14). A sample display of the Sensor menu is shown in Figure 3-13.

**3-25.** The instrument is capable of using sensor calibration data from either the sensor data adapters or from any one of four internal tables. The sensor calibration data contained within the sensor data adapter is only accessible to the installed channel. For example, Channel 1 can use the sensor calibration data from any of the internal tables or the sensor data adapter 1. Similarly, Channel 2 can use the sensor calibration data from any of the internal tables or the sensor data adapter 2.

**3-26.** Referring to Figure 3-13, the cursor can be positioned to three fields. The two fields below the 'CH1' and 'CH2' indicate the serial number of the sensor whose calibration data is

|   |   |   |   |   |   |   |   |  |  |  |  |  |   |  |  |  |  |  |  |  |
|---|---|---|---|---|---|---|---|--|--|--|--|--|---|--|--|--|--|--|--|--|
| R | T | N |   |   |   | < |   |  |  |  |  |  |   |  |  |  |  |  |  |  |
| S | E | L | F | T | E | S | T |  |  |  |  |  | < |  |  |  |  |  |  |  |
| S | W | I | T | C | H | E | S |  |  |  |  |  |   |  |  |  |  |  |  |  |
| R | E | C | O | R | D | E | R |  |  |  |  |  |   |  |  |  |  |  |  |  |

Figure 3-12. Diagnostics Menu Display

TABLE 3-6. DIAGNOSTICS MENU FUNCTIONS

| Command   | Description   | Parameters | Default |
|-----------|---|------------|---------|
| RTN       | Returns the instrument to the previous menu.  | n/a        | n/a     |
| SELF TEST | Instructs the instrument to perform internal diagnostics and the display test.  | n/a        | n/a     |
| SWITCHES  | Interactive test to verify proper operation of the front panel switches.  | n/a        | n/a     |
| RECORDER  | The recorder output DAC is exercised through its full range from 0 to 10 V.D.C. in 1V steps continuously until the <Menu> key is depressed. | n/a        | n/a     |

|   |   |   |   |  |   |   |   |   |   |   |   |   |   |   |   |   |   |   |  |  |
|---|---|---|---|--|---|---|---|---|---|---|---|---|---|---|---|---|---|---|--|--|
|   |   |   |   |  |   |   | C | H | 1 |   |   |   |   | C | H | 2 |   |   |  |  |
| S | E | R | # |  | > | 5 | 0 | 1 | 4 | 0 |   |   |   | 4 | 2 | 9 | 1 | 0 |  |  |
|   |   |   |   |  |   |   |   |   |   |   |   |   |   |   |   |   |   |   |  |  |
| E | D | I | T |  | D | A | T | A |   |   | 5 | 0 | 1 | 4 | 0 |   |   |   |  |  |

Figure 3-13. Sensor Display Menu

Section III  
Operation

selected for channels 1 and 2 respectively. The instrument uses this data for the linearity and high frequency correction data and automatically applies the correction to the measured value.

**3-27.** To change the current selection for channel 1, use the arrow keys to move to the SER# command line and position the cursor below the 'CH1' field. Press the <Enter> key and use the up/down arrow keys to scroll through the parameter list. The parameter list typically consists of serial numbers for each power sensor. Scroll through the list until the desired serial number is displayed and press <Enter> to accept. Move the cursor below the 'CH2' field and follow the same procedure used to change the table for channel 2.

**3-28.** The instrument detects the presence of the sensor data adapter and automatically down-loads the sensor calibration

data. This occurs when the power to the unit is first applied or after plugging the sensor data adapter into the instrument. The power sensor and corresponding sensor data adapter have matching serial numbers for maintaining them as a matched pair.

**3-29.** The parameter list will show TBLn (where n = 1, 2, 3, 4) when a serial number has not been entered for the corresponding internal table. For example, TBL3 will be displayed if the serial number has not been previously entered for internal table 3. In addition, the parameter list will show ADPTn (where n = 1, 2) if a serial number has not been entered for the table contained within the sensor data adapter. For

**EDIT DATA ACCESS CODE**

The access code to enter the Edit Data menu is as follows:  
Press the front panel switches in the following order:  
<FREQ> <AVG> <AVG> <FREQ> <Sensor> <Enter>

**Figure 3-14. Access Code**

|   |   |   |   |   |   |   |   |   |  |   |   |   |   |   |   |   |   |   |   |
|---|---|---|---|---|---|---|---|---|--|---|---|---|---|---|---|---|---|---|---|
| R | T | N |   |   |   |   |   |   |  |   |   |   |   |   |   |   |   | ∨ | ∧ |
| M | O | D | E | L |   |   |   |   |  | 5 | 1 | 0 | 7 | 5 |   |   |   |   |   |
| S | E | R | I | A | L |   | # |   |  | > | 4 | 2 | 9 | 1 | 0 |   |   |   |   |
| D | A | T | E |   |   |   |   |   |  | 0 | 7 | / | 2 | 9 | / | 9 | 6 |   |   |
| U | P | S | C | A | L | E |   |   |  | 0 | : | 4 | 0 | 6 | 5 |   |   |   |   |
| D | O | W | N | S | C | A | L | E |  | 0 | : | 0 | 0 | 0 | 0 |   |   |   |   |
| F | R | E | Q |   | C | . | F | . |  |   |   |   |   |   |   |   |   |   |   |
| M | A | X |   | F | R | E | Q |   |  | 1 | 8 | . | 0 | 0 |   |   |   |   |   |
| M | I | N |   | F | R | E | Q |   |  | 0 | . | 0 | 3 |   |   |   |   |   |   |
| M | A | X |   | P | O | W | E | R |  | + | 2 | 0 | . | 0 | 0 |   |   |   |   |
| M | I | N |   | P | O | W | E | R |  | - | 7 | 0 | . | 0 | 0 |   |   |   |   |

**Figure 3-15. Edit Data Menu Display**

|  |   |   |   |   |   |   |   |   |   |   |  |  |   |   |   |   |   |   |
|--|---|---|---|---|---|---|---|---|---|---|--|--|---|---|---|---|---|---|
|  | R | T | N |   |   |   | F | R | E | Q |  |  | C | A | L |   | ∨ | ∧ |
|  | 0 |   |   | > | 0 | 0 | 0 | . | 0 | 3 |  |  | + | 0 | 0 | . | 0 | 0 |
|  | 1 |   |   |   | 0 | 0 | 2 | . | 0 | 0 |  |  | + | 0 | 0 | . | 0 | 1 |
|  | 2 |   |   |   | 0 | 0 | 3 | . | 0 | 0 |  |  | + | 0 | 0 | . | 0 | 4 |

**Figure 3-16. Cal Factor Menu Display**



example, ADPT2 is displayed when the serial number has not been previously entered for sensor data adapter 2.

**3-30.** To edit the sensor calibration data, move the cursor to the EDIT DATA function and press <Enter>. Scroll through the power sensor serial numbers until the desired selection is displayed. Press <Enter> to proceed. Enter the access code to edit or depress the <Menu> key to escape. (See Figure 3-14.)

**3-31. Edit Data Menu.** An example of the Edit Data menu is shown in Figure 3-15. Table 3-7 contains a description of the commands and associated parameters.

**3-32. Linearity Factors.** Seven upscale and downscale

linearity factors are assigned to each power sensor. These values can be viewed or edited by moving the cursor to the UPSCALE or DOWNSCALE command and pressing the <Enter> key. The instrument will sequence through the linearity factors by pressing the up/down arrow keys. If a value is to be edited, scroll to the desired linearity factor, use the right arrow key to move the cursor to the first digit in value field and then use the up/down arrow keys to increment/decrement the number. Set the remaining digits in the same manner. If another value needs to be changed, move the cursor back to the range field and use the up/down arrow keys to display the next value to be modified. Press the <Enter> key when all of the changes have been entered.

**TABLE 3-7. EDIT DATA MENU FUNCTIONS**

| Command    | Description  | Parameters  | Default  |
|------------|--|---|----------|
| RTN        | Returns the instrument to the previous menu          | n/a   | n/a      |
| MODEL      | Power sensor model number                            | 0 to 99999  | 0        |
| SER #      | Power sensor serial number                           | 0 to 99999  | 0        |
| DATE       | Calibration date                                     | MM/DD/YY<br>Where:<br>MM = 01 to 12<br>DD = 01 to 31<br>YY = 00 to 99 | 01/01/01 |
| UPSCALE    | Upscale linearity factors                            | Range: Factor<br>[0 to 6] : [0 to 9999]                               | 5000     |
| DOWNSCALE  | Downscale linearity factors                          | Range : Factor<br>[0 to 6] : [-999 to 999]                            | 0        |
| CAL FACTOR | Brings the instrument to the calibration factor menu | n/a   | n/a      |
| MAX FREQ   | Power sensor's maximum frequency                     | 0, 100.00 GHz   | 18       |
| MIN FREQ   | Power sensor's minimum frequency                     | 0, 100.00 GHz   | 0.03     |
| MAX POWER  | Power sensor's maximum                               | [-99.99, 99.99] dBm   | 20       |
| MIN POWER  | Power sensor's minimum power input                   | [-99.99, 99.99] dBm   | -75      |

**3-33. FREQUENCY Calibration Factors.** Up to 60 sensor frequency calibration factors can be entered for each power sensor. Position the cursor to the **FREQ C.F.** command. Press the <Enter> key to advance to the Cal Factor menu. A sample of the display is shown in Figure 3-16. A sample of the display is shown in Figure 3-16 and an explanation of the commands is shown in Table 3-8.

**3-34.** The up/down arrow keys are used to scroll through the calibration factor table. Use the arrow keys to move to the desired field and press the <Enter> key to change a value. The up/down arrow keys increment/decrement the value and the left/right arrows keys select the digits. Press the <Enter> key when the desired value is displayed. Move the cursor to the RTN field or depress the <Menu> key to return to the Sensor menu.

**3-35.** The instrument scans the sensor calibration table for a value that matches the operating frequency. Linear interpolation is used if the operating frequency is between two

| Factor # | Frequency (GHz) | Cal Factor (dB) |
|----------|-----------------|-----------------|
| 0        | 1               | 0.00            |
| 1        | 2               | 0.08            |
| 2        | 3               | -0.02           |
| 3        | 4               | -0.15           |
| 4        | 5               | -0.08           |
| 5        | 6               | -0.08           |

| Factor # | Frequency (GHz) | Cal Factor (dB) |
|----------|-----------------|-----------------|
| 0        | 1               | 0.00            |
| 1        | 2               | 0.08            |
| 2        | 3               | -0.02           |
| 3        | 3.5             | -0.01           |
| 4        | 4               | -0.15           |
| 5        | 5               | -0.08           |
| 6        | 6               | -0.08           |

Figure 3-17. Calibration Data Example

TABLE 3-8. Sensor Calibration Menu Functions

| Command | Description                       | Parameters         | Default |
|---------|-----------------------------------|--------------------|---------|
| FREQ    | Frequency                         | 0.01 to 100.00 GHz | 0.05    |
| CAL     | High frequency calibration factor | -3.00 to 3.00 dB   | 0.00    |

of the table entries. To ensure proper operation, the calibration table must be entered in ascending order and terminated in the last table entry with a zero (0) value for both the **FREQ** and **CAL FACTOR**. In addition, new calibration values should be entered while adhering to the chronological order of the table. For example, to add the -0.01 dB calibration factor at 3.5 GHz to the example shown in Figure 3-17, the calibration factors for items four through six are re-entered.

**3-36. Save.** Exiting the **EDIT DATA** menu displays the confirmation menu as shown in Figure 3-18. Move the cursor to **YES** to save the edited parameters or **NO** to leave the data unchanged.

**3-37. FREQ Key.**

**3-38.** The frequency of the signal being measured must be entered in order to use the stored high frequency calibration factors. The instrument will then compute, display and apply the required correction factor to subsequent measurements.

**3-39.** The operating frequency is entered by pressing the <FREQ> key. The instrument will advance to the Frequency menu as shown in Figure 3-19. The frequency for Channel 1 is entered by positioning the cursor to the value field under the **CH1** heading and pressing the <Enter> key. A value between 0.01 GHz and 100 GHz can be entered. The power on default is 0.05 GHz. Once the frequency is entered, the corresponding Cal Factor is displayed in dB beneath the frequency.

**3-40. AVG Key.**

**3-41.** The averaging time may be adjusted to optimize measurement speed and display stability. Averaging time, in seconds, can be adjusted in 0.05 increments to a maximum of 20.00 seconds. The length of the filter in number of samples is shown on the display.

**3-42.** To adjust the averaging time, press the <AVG> key and the instrument will display the screen as shown in Figure 3-20. Position the cursor under the desired channel heading and press the <Enter> key. Use the arrow keys to set the desired value and then press <Enter> to accept. Entering 00.00 selects the auto filtering Mode. This menu can be accessed to show the filter setting in the auto mode.

**3-43. ZERO/CAL Key.**

**3-44.** Zeroing should be performed when the unit is first warmed-up, a sensor has been changed or the instrument has drifted a significant amount with respect to the signal level being measured. For large signals (measurements taken on

|   |   |   |   |   |   |   |  |   |   |   |   |  |  |  |  |   |       |
|---|---|---|---|---|---|---|--|---|---|---|---|--|--|--|--|---|-------|
| C | O | N | F | I | R | M |  | S | A | V | E |  |  |  |  |   |       |
|   |   |   |   |   |   |   |  |   |   |   |   |  |  |  |  | > | N O   |
|   |   |   |   |   |   |   |  |   |   |   |   |  |  |  |  |   | Y E S |
|   |   |   |   |   |   |   |  |   |   |   |   |  |  |  |  |   |       |

Figure 3-18. Save Display

|   |   |   |   |   |   |   |   |   |   |   |   |   |   |   |   |   |   |   |   |   |   |
|---|---|---|---|---|---|---|---|---|---|---|---|---|---|---|---|---|---|---|---|---|---|
| F | R | E | Q | U | E | N | C | Y |   |   |   |   |   |   |   |   |   |   |   |   |   |
|   |   |   |   |   |   |   | C | H | 1 |   |   |   |   | C | H | 2 |   |   |   |   |   |
| G | H | z |   |   |   |   | > | 0 | 1 | 8 | . | 0 | 0 |   |   | 0 | 0 | 2 | . | 5 | 0 |
| d | B | C | F |   |   |   |   | 0 | 0 | 0 | . | 1 | 0 |   |   | - | 0 | 0 | . | 0 | 2 |

Figure 3-19. Frequency Display

|   |   |   |   |  |  |  |   |   |   |   |   |   |  |   |   |   |   |   |   |  |
|---|---|---|---|--|--|--|---|---|---|---|---|---|--|---|---|---|---|---|---|--|
| T | I | M | E |  |  |  |   |   |   |   |   |   |  |   |   |   |   |   |   |  |
|   |   |   |   |  |  |  | C | H | 1 |   |   |   |  | C | H | 2 |   |   |   |  |
| S | E | C |   |  |  |  | > | 1 | 0 | . | 5 | 0 |  |   | 0 | 0 | . | 8 | 0 |  |
|   |   |   |   |  |  |  |   |   |   |   |   |   |  |   |   |   |   |   |   |  |

Figure 3-20. Averaging Time Display

|   |   |   |   |  |  |  |   |  |   |   |   |  |  |   |   |   |  |   |   |   |  |
|---|---|---|---|--|--|--|---|--|---|---|---|--|--|---|---|---|--|---|---|---|--|
|   |   |   |   |  |  |  |   |  |   |   |   |  |  | C | H | 1 |  | C | H | 2 |  |
| Z | E | R | O |  |  |  | & |  | C | A | L |  |  | > |   |   |  |   |   |   |  |
| Z | E | R | O |  |  |  |   |  |   |   |   |  |  |   |   |   |  |   |   |   |  |
| C | A | L |   |  |  |  |   |  |   |   |   |  |  |   |   |   |  |   |   |   |  |

Figure 3-21. Zero and Calibration Display

|   |   |   |   |   |   |   |   |   |   |   |   |   |   |   |   |   |   |   |   |   |  |
|---|---|---|---|---|---|---|---|---|---|---|---|---|---|---|---|---|---|---|---|---|--|
| R | E | F | E | R | E | N | C | E |   | L | E | V | E | L |   |   |   |   |   |   |  |
|   |   |   |   |   |   |   | C | H | 1 |   |   |   |   | C | H | 2 |   |   |   |   |  |
| d | B | m |   |   |   |   | + | 0 | 0 | . | 0 | 0 |   |   | + | 2 | 5 | . | 0 | 0 |  |
| M | O | D | E |   |   |   | L | O | A | D |   |   |   |   | S | E | T |   |   |   |  |

Figure 3-22. Reference Level Display

**TABLE 3-9. REFERENCE LEVEL MENU FUNCTIONS**

| Command | Description  | Parameters          | Default |
|---------|--|---------------------|---------|
| dBm     | Reference level value in Preset mode.  | -99.99 to 99.99 dBm | 0       |
| MODE    | Reference level mode. "LOAD" makes the current channel measurement as the reference level. The Set mode is used to select the entered reference level. The Off mode disables the reference level adjustment. | LOAD, SET, OFF      | OFF     |

range 4, 5, or 6), this may be done once every several hours. For small signals, (measurements taken on range 0, 1, 2, or 3), zeroing should be done before each measurement for optimum results. When zeroing is performed, the instrument calculates and stores zero corrections for each range, and applies the corrections to subsequent measurements.

**3-45.** The built-in 50 MHz calibrator provides a convenient means for calibrating the instrument. Calibration can be performed any time to assure accuracy.

**3-46.** The <Zero/CAL> key invokes three commands as shown in Figure 3-21.

**3-47.** The cursor can be positioned in any of the six fields that are indicated by the '>' symbol in Figure 3-21. To zero and calibrate Channel 1 of the Model 4230A, connect the power sensor to the internal 50 MHz 0 dBm calibrator, move to the ZERO & CAL command and position the cursor in the CH1 field and press <Enter>. The unit will display ZEROING:CHANNEL 1, Range#" followed by CALIBRATE:CHAN 1 and then return to the measurement display when complete. If a power level is detected during zeroing, the instrument will not zero and will display the error message "ZEROERROR:CHAN 1". If a 0 dBm signal is not detected during the Calibrate function, the display will indicate "CALIBRATOR:CHAN 1 -NOT CONNECTED-". The Zero and Calibrate functions can also be invoked individually with the ZERO and CAL commands.

**3-48. REF LEVEL Key.**

**3-49.** Press the <REF Level> key to enter a value or to use the current channel measurement for the reference level. The measurement units will automatically change to dBr for subsequent measurements. An example of the instrument's display is shown in Figure 3-22.

**3-50.** To set a reference level, depress the <REF Level> key to display the REFERENCE LEVEL sub-menu. Move the cursor to the reference value for the appropriate channel. (Channel 1 is default.) Depress the <Enter> key to initiate the editing process. Use the arrow keys to edit the reference value in dBm. Once the desired value has been selected, depress the <Enter> key to leave the editing function. To use this value as the reference, depress the <Down> arrow key to MODE, depress the <Enter> key for mode selection and using the <Up> or <Down> arrow keys, select SET. Depressing the <Enter> key will place the appropriate channel to the "dBr" mode of operation using the set value as the reference.

The instrument cal also load the current measured value as the reference level. To do this, depress the <REF Level> key to display the REFERENCE LEVEL sub-menu. Navigate the cursor using the arrow keys to the MODE selection of the desired channel. Depress the <Enter> key for mode selection and using the <Up> or <Down> arrow keys, select LOAD. Depressing the <Enter> key will place the appropriate channel to the dBr mode of operation using the measured value as the reference level.

## SECTION IV APPLICATION NOTES

### 4-1. INTRODUCTION.

**4-2.** This section provides detailed background information on various aspects of operation of the Model 4230A. It is assumed that the reader is familiar with the basic operating procedures covered in Section III. This section covers the following topics:

- a. Sensor calibration
- b. Zeroing
- c. Filtering
- d. Noise
- e. Dynamic range
- f. Measurement time
- g. High frequency accuracy
- h. Chart recorder operation
- i. Waveform sensitivity
- j. Remote operation

### 4-3. SENSOR CALIBRATION.

**4-4. General.** Two types of calibration are associated with the Model 4230A - instrument calibration and sensor calibration. The instrument (less sensors) must be calibrated using a stable and accurate DC source, such as the Boonton Model 2510, to ensure interchangeability of sensors. Instrument calibration procedures are covered in the Model 4230A Service Manual. Sensor calibration data is of two types: linearity and high frequency calibration factors. Sensor calibration data for up to four sensors can be stored in non-volatile EEPROM plus each sensor data adapter contains the data matched to the corresponding power sensor.

**4-5. 14-Point Linearity Data.** Linearity data, also referred to as AC reference frequency linearity data, is supplied with the sensor and can be manually entered into the non-volatile Tables or Adapters. For sensors ordered with the instrument, linearity data is stored in the sensor data adapter before the instrument is shipped.

**4-6.** At the reference frequency (50 MHz, or 40, 60, or 94 GHz), each sensor has two gain factors for each range: upscale and downscale points. Refer to Figure 4-1. The upscale points are in the range of 4000-7000, which is a gain correction factor. Upscale points are calibrated at the factory at about 70% of full scale. The downscale number is an offset correction at about 25% of full scale. Thus, for a diode sensor (7 ranges), there are 14 points; for thermal sensors there are eight points. Ranges 0 and 1 share the same data points.

**4-7. High Frequency Calibration Points.** In addition to linearity data, there are high frequency calibration points. Calibration points covering the entire sensor frequency range are supplied with each sensor. Below 1 GHz, the sensor response is flat, and frequency calibration points need not be entered.

**4-8.** The Model 4230A provides space for up to 60 points for each sensor table. Frequency calibration points need not be in equal frequency increments; however, the entry of data must be done in ascending order of frequency. For both diode and thermal sensors, a calibration factor of 0 dB is implied at 0.00 GHz so that the instrument may be operated below the first data point.

### 4-9. ZEROING.

**4-10.** The automatic zeroing routine of the instrument takes measurements on the lowest five ranges and applies these as correction factors on subsequent measurements. Offsets in the sensor and input amplifiers are linearly corrected in the internal software. Offsets on the highest ranges are below 0.02% of full scale, and do not need correction.

**4-11.** Input power to the sensor must be removed before the zeroing function is executed or an error message will be displayed. The instrument will perform zeroing, however, if the signal is less than full scale on range 0. This feature provides a great deal of offset capability for temperature effects without rezeroing the input amplifier hardware.

**4-12.** For full accuracy at low signal levels, power must be removed from the sensor several seconds before zeroing to allow the sensor to settle. This is especially true if a large signal had been applied to the sensor in the previous 20 seconds or so because of the dielectric absorption of the capacitors in diode sensors, and because of thermal retention in thermal sensors. The error resulting from different input conditions can be determined from Figure 4-2 or 4-3, as applicable. The curves in these figures show the decay of measured power after a large signal has been applied. The typical error that can be expected by zeroing too quickly after application of a large signal is equal to the offset power at the time of zeroing.

**4-13.** The Model 4230A initiates zeroing when the ZERO & CAL or ZERO commands are invoked. The user must delay zeroing according to system requirements when the sensors are used over a wide dynamic range. For example, if it is determined from the application that five seconds are required from power off to the zeroing operation, then the user should wait five seconds after removing power from the sensor before executing the zero command.

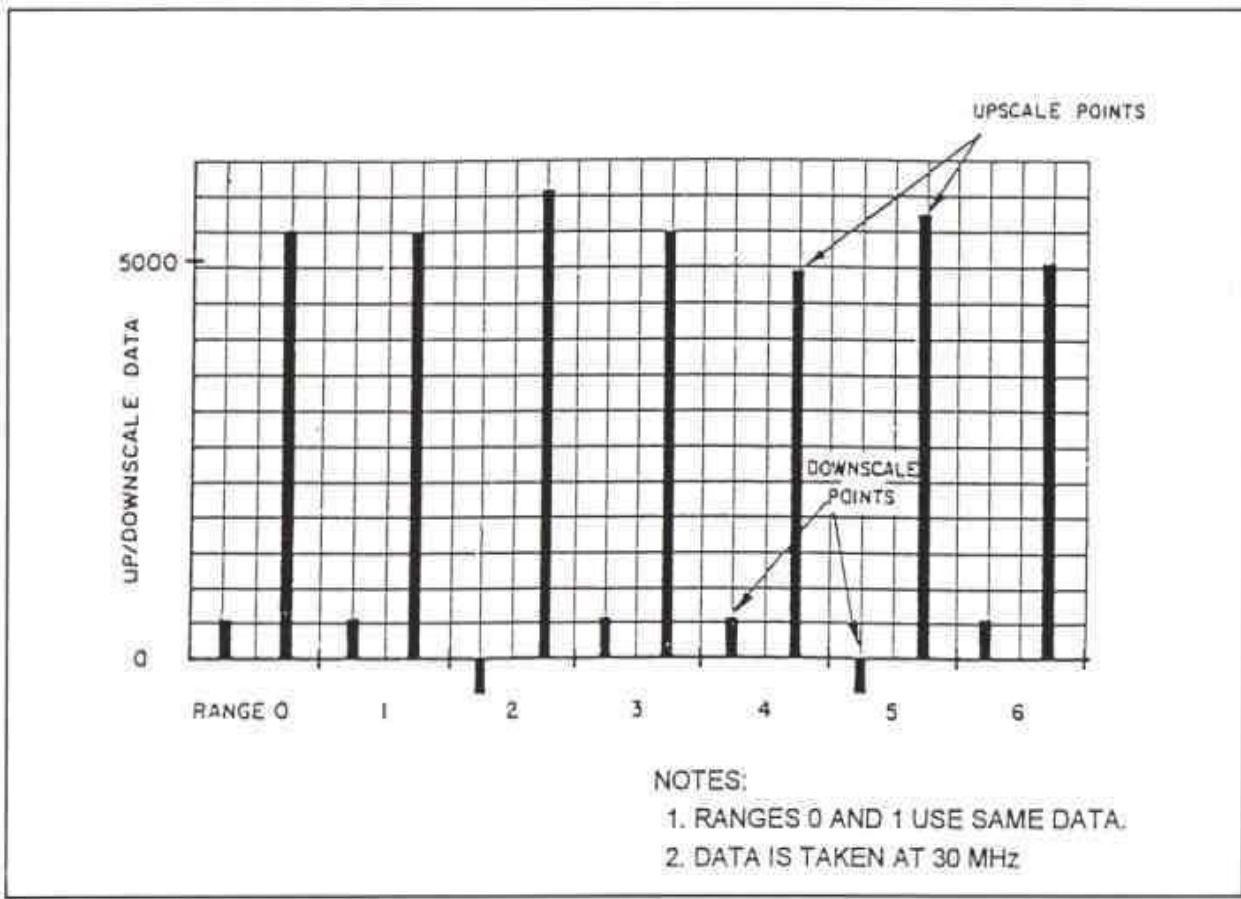

Figure 4-1. 14-Point Sensor Calibration

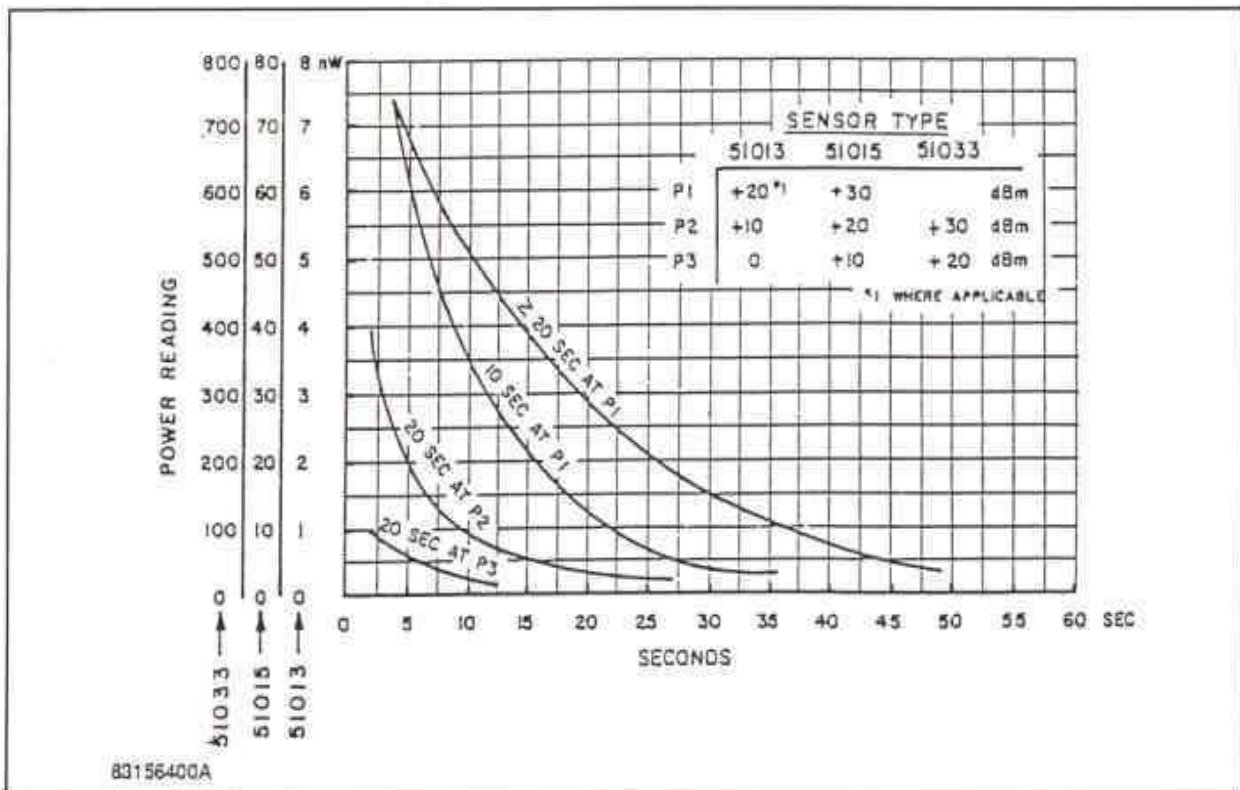

Figure 4-2. Diode Sensor Decay

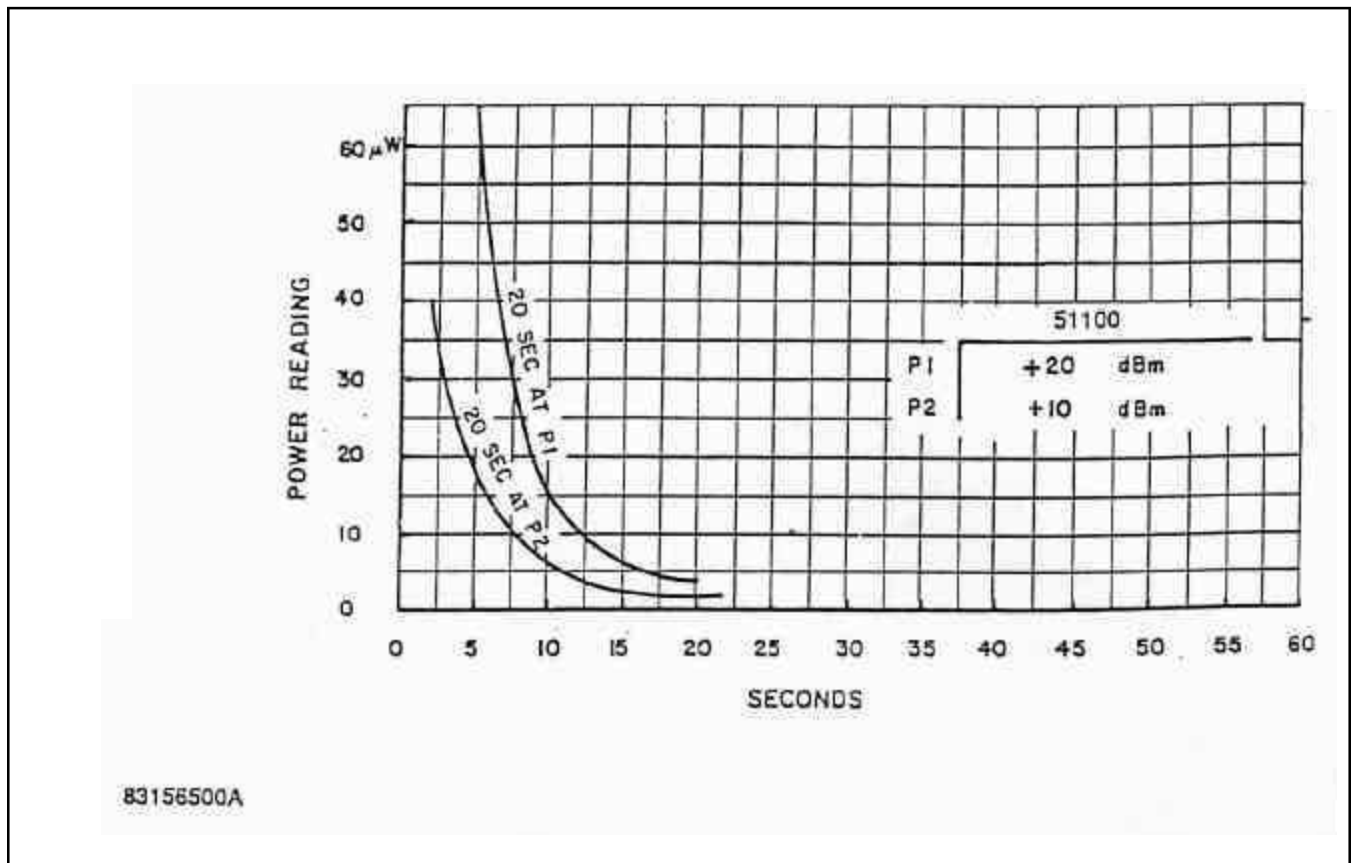

Figure 4-3. Thermal Sensor Decay

**4-14.** The zeroing time on each range has been optimized for speed and accuracy. Total zeroing time is approximately 30 seconds.

**4-15.** Zeroing should be done when the instrument is turned on, the sensor has been changed, or the instrument has drifted a significant amount with respect to the signal being measured. For large signals (range 4, 5, or 6), this may be once every several hours, if at all. For very small signals (range 0, 1, 2, or 3), for optimum results, zeroing be done immediately before each measurement.

**4-16. DYNAMIC RANGE.**

**4-17.** The hold range mode is useful when it is known that the signal will vary over a certain limited range. (The hold range mode is active when a specific instrument range, other than autorange, has been selected.) The dynamic range of this mode is limited by the zero offset and the resolution, as shown in Figure 4-4. It can be seen from this figure that the useful dynamic range is 20 dB if the error is to be kept below 0.1 dB. An asterisk is displayed before the channel when the measured value is below the lower range limit indicating an uncalibrated measurement.

**4-18. FILTERING.**

**4-19.** The Model 4230A employs digital filtering (averaging of measurements) to reduce the noise floor of the instrument and to stabilize measurements. The default values are optimized for speed and low noise under general conditions. Default values for normal and fast modes are as follows:

| <u>Range</u> | <u>Normal (sec.)</u> | <u>Fast (sec.)</u> |
|--------------|----------------------|--------------------|
| 0            | 2.8                  | 2.8                |
| 1            | 0.8                  | 0.8                |
| 2            | 0.8                  | 0                  |
| 3            | 0.8                  | 0                  |
| 4            | 0.8                  | 0                  |
| 5            | 0.8                  | 0                  |
| 6            | 0.8                  | 0                  |

**4-20.** The filtering technique used is digital pipeline filtering, also referred to as circular filtering or moving average filtering. The displayed measurement is simply an equally weighted average of the last  $x$  seconds worth of samples, where  $x$  is the filter length in seconds. For purposes of noise and settling time, the number of samples is not important, but the time is important. For example, if a three second filter is used, the noise is the same whether 60 or 600 samples are taken in that interval, provided that the samples are taken above a certain rate. For this reason, filter selection in the Model 4230A is done on the basis of seconds, rather than the number of samples.

**4-21.** The bottom end sensitivity of the instrument is limited by sensor noise. An RMS noise specification is valid since the sensor noise and the amplifier noise are band-limited and Gaussian. The noise level, specified in picowatts at a certain filter length, is sufficient to calculate the error due to noise at any signal level, for any filter, as shown in the discussion of noise that follows.

**4-22. NOISE.**

**4-23. Noise Reduction.** The amount of noise reduction that can be realized has no theoretical limitation, except that drift enters into the picture at filter lengths over 20 seconds. The digital filter has a bandwidth and rolloff curve just as any filter does; the bandwidth can be reduced arbitrarily. The effective noise bandwidth is  $0.469/t$ , where  $t$  is the filter length. For example, with a filter length of 4 seconds, the equivalent noise bandwidth is 0.12 Hz.

**4-24.** Figure 4-5 is a nomograph showing the noise reduction that applies for various filter lengths, given the sensor noise with 2.8 second filtering. (This is the time for which diode sensor noise is specified.) Noise power is inversely proportional to the square root of the filter length. Normally, noise power varies directly with filter bandwidth; however, because power sensors are square-law devices (detected voltage is proportional to power), the noise power is proportional to the square root of the bandwidth. This can be demonstrated

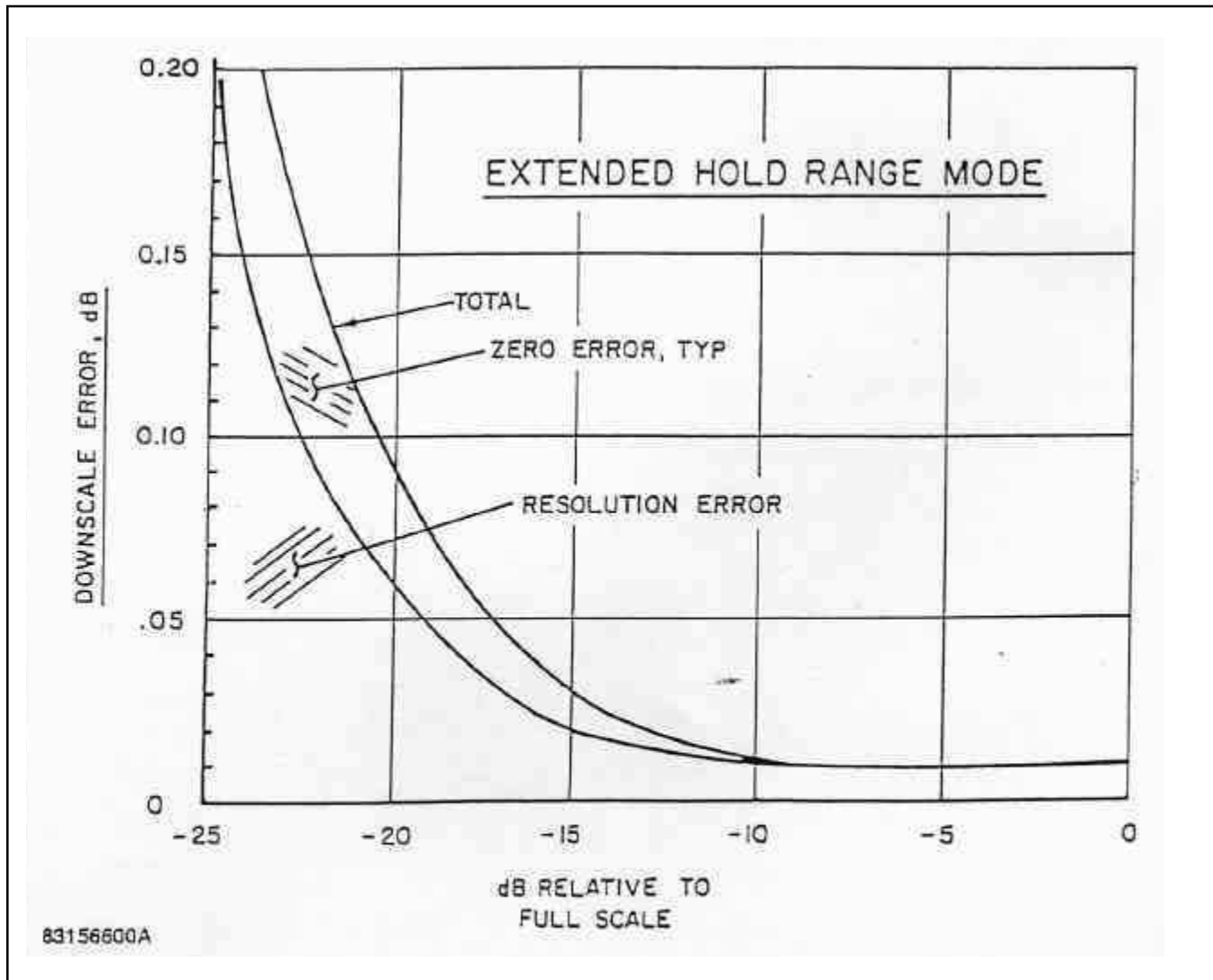

Figure 4-4. Extended Hold Range Mode



with noise measurements. At very low filter lengths (less than 150 milliseconds), however, the noise does not increase without bound for all sensors because the input amplifier noise is restricted with hardware filters. This additional filtering is not shown in the nomograph.

**4-25. Error Computation.** Since the noise is Gaussian, both before and after filtering, statistics show the level of confidence factor that can be associated with a given reading. (At medium and high power levels, the confidence factor is essentially unity.) Figure 4-6 shows a typical set of samples and a typical error band specification of 2 sigma. Under these conditions, 95.4% of the readings will fall within  $\pm 2$  sigma.

**4-26.** Figure 4-7 shows the confidence factor for other error bands. The error band is expressed in pW, regardless of the power level. (The percentage error band can also be calculated as shown below.) The RMS noise is taken from the sensor specifications and modified as necessary for filter lengths other than 2.8 seconds. Knowing any two of the three parameters (error band, RMS noise, and confidence factor), the third can be computed. For example, if the sensor RMS noise is 65 pW and the confidence factor is to be 95.4%, the error band is 130 pW, single sided ( $\pm 130$  pW). If this were the case, at a measurement level of 1300 pW the percent error band would be 10%, corresponding to about  $\pm 0.44$  dB.

**4-27. Noise Error Examples.** Figures 4-8 and 4-9 show the computed error for the 51013 diode sensor at different power levels, for 2.8 and 10 second filters. To attain these results, the sensor must be at a stable temperature, and zeroing must be done immediately before the measurement is taken.

**4-28. Integration of Power.** With long filtering, instrument readings may seem erroneous because the filter has not been cleared. For example, with a 20 second filter, if a 2 second RF pulse is applied, the instrument display will indicate a nonzero level for 18 seconds after the pulse has terminated. Additional pulses will be integrated along with the first until, by the process of selective deletion, the pulses are removed one at a time from the filter. Actually, measurement samples are deleted, not the pulses, giving rise to a ramping effect at the instrument display/output. This is shown in Figure 4-10. In all senses, the filter is a simple integrator.

**4-29. Clearing of Filter.** When long filter times are used, it may become troublesome at times to wait for the filter to clear. If the Auto filter function is selected, the filter is cleared after significant power changes, and filtering then resumes. Clearing can also be accomplished by changing the filter length to any different value and then resetting it using the interface bus; however, with bus operation, most of the trigger modes clear the filter at trigger time.

**4-30. Partial Results.** Measurement time is affected by the filter since valid readings to within a certain error band can be obtained only when the filter is full. If the filter has been cleared, data is available at reduced accuracy immediately after

the first 50 millisecond sample period. The filter uses the number of samples as a divisor when computing the average, and the output/display does not ramp but homes in on the result instead as the samples accumulate.

#### 4-31. MEASUREMENT TIME.

**4-32. Step Response.** The measurement time from a power input step is the sum of the overhead time and the length of the digital filter, where the overhead time is defined as the time delay due to sensor response time and measurement software (processing). The overhead time is given in paragraph 4-34 for certain conditions.

**4-33. Continuous Response.** Regardless of the overhead time or the digital filter length, the Model 4230A will output readings at a maximum rate of about 200/second with the display operating. As the sensor and the digital filter settle, readings will ramp up or down at that rate.

**4-34. Overhead Time.** Overhead time is <350 milliseconds for diode sensors and <450 milliseconds for thermal sensors under the following conditions:

- a. Settling to 99% or 0.04 dB of final power
- b. Power step of 10 dB
- c. Range does not change
- d. Digital filter set to minimum

**4-35.** The power step may be upward or downward. Smaller power steps will decrease this time slightly; larger power steps in the downward direction will increase the time significantly. A 40 dB downward step, for example, will take several seconds to settle to 0.04 dB.

**4-36. Digital Filter.** The digital filter is a moving average or pipeline filter which simply integrates the readings over the last x seconds, where x is the filter length. A step input to the filter will produce a linear ramp at the output, terminating when the filter is full.

**4-37. Default Filter Lengths.** Although any filter length from 0 to 20 seconds may be chosen, default filter lengths are programmed into the instrument for optimum general conditions. (Refer to paragraph 4-19.) For diode sensors, the range break-points are roughly in 10 dB steps, with the range 0 to 1 break-points at approximately -54 dBm.

**4-38. Settled Measurement Time.** In the free run settled mode, output data updates are held off until the measurements have settled.

**4-39. Fast Mode Measurement Time.** The Fast Mode can be invoked over the bus to put the instrument into its fastest sampling mode. Output data is taken after digital filtering and achieves sample rates that are dependent on the applied power level. Figure 4-11 shows this relationship.

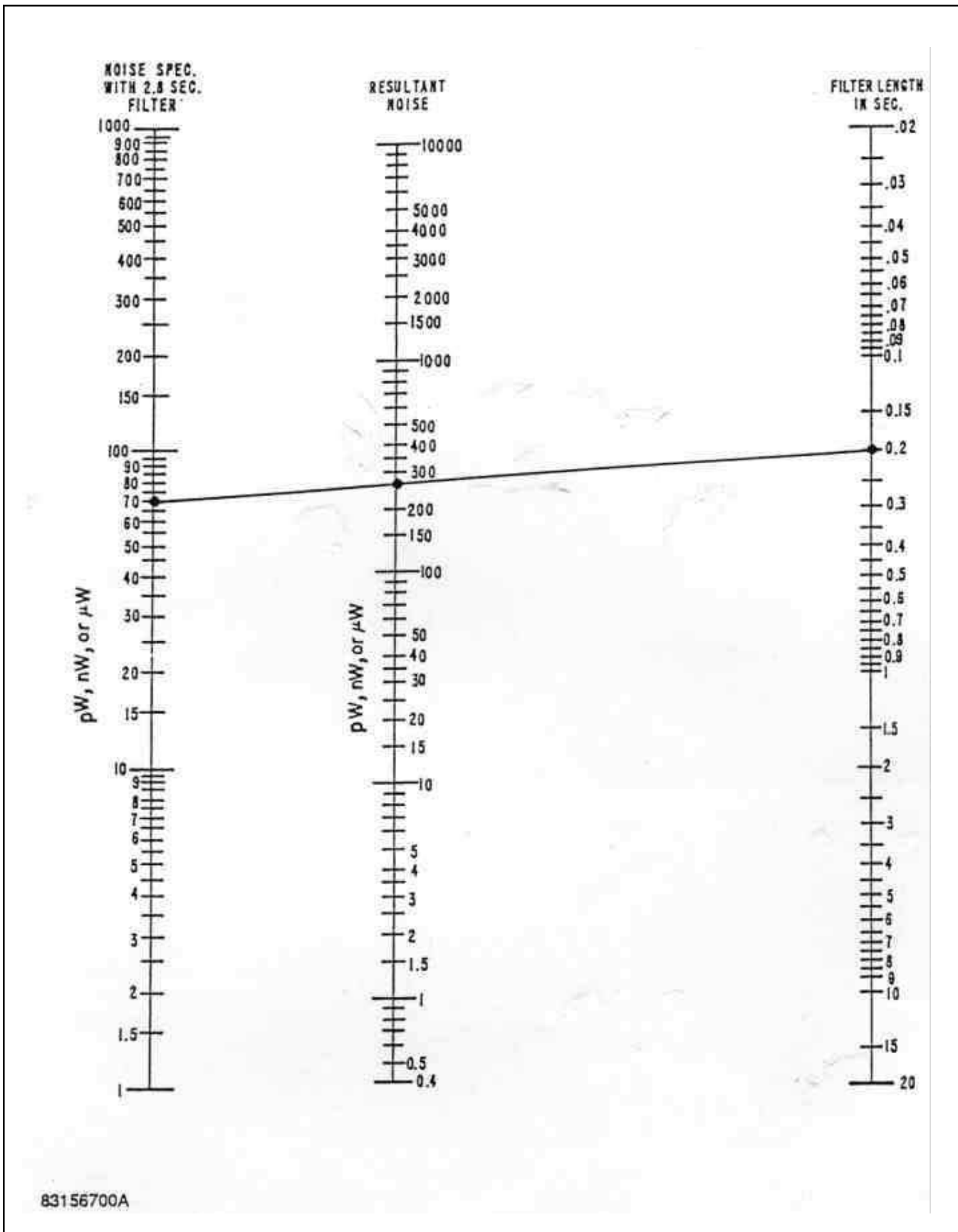

83156700A

Figure 4-5. Noise Reduction

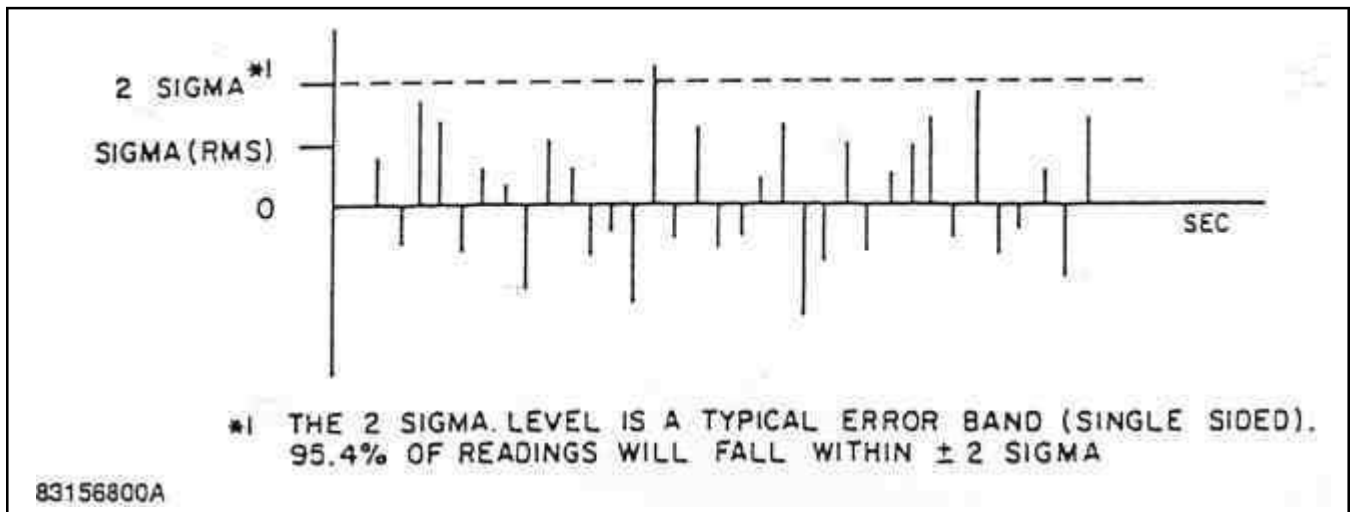

Figure 4-6. Typical Error Band Specifications

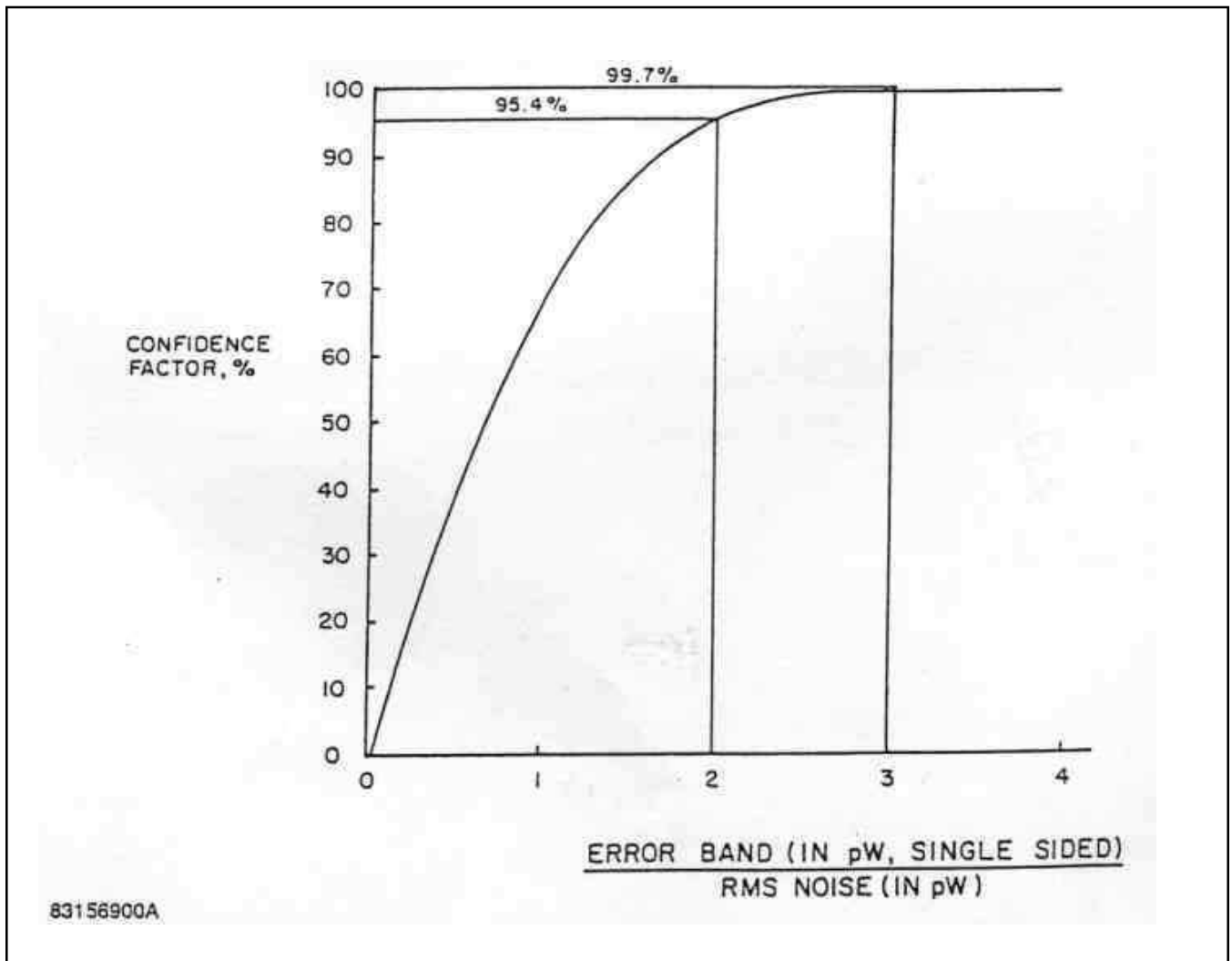
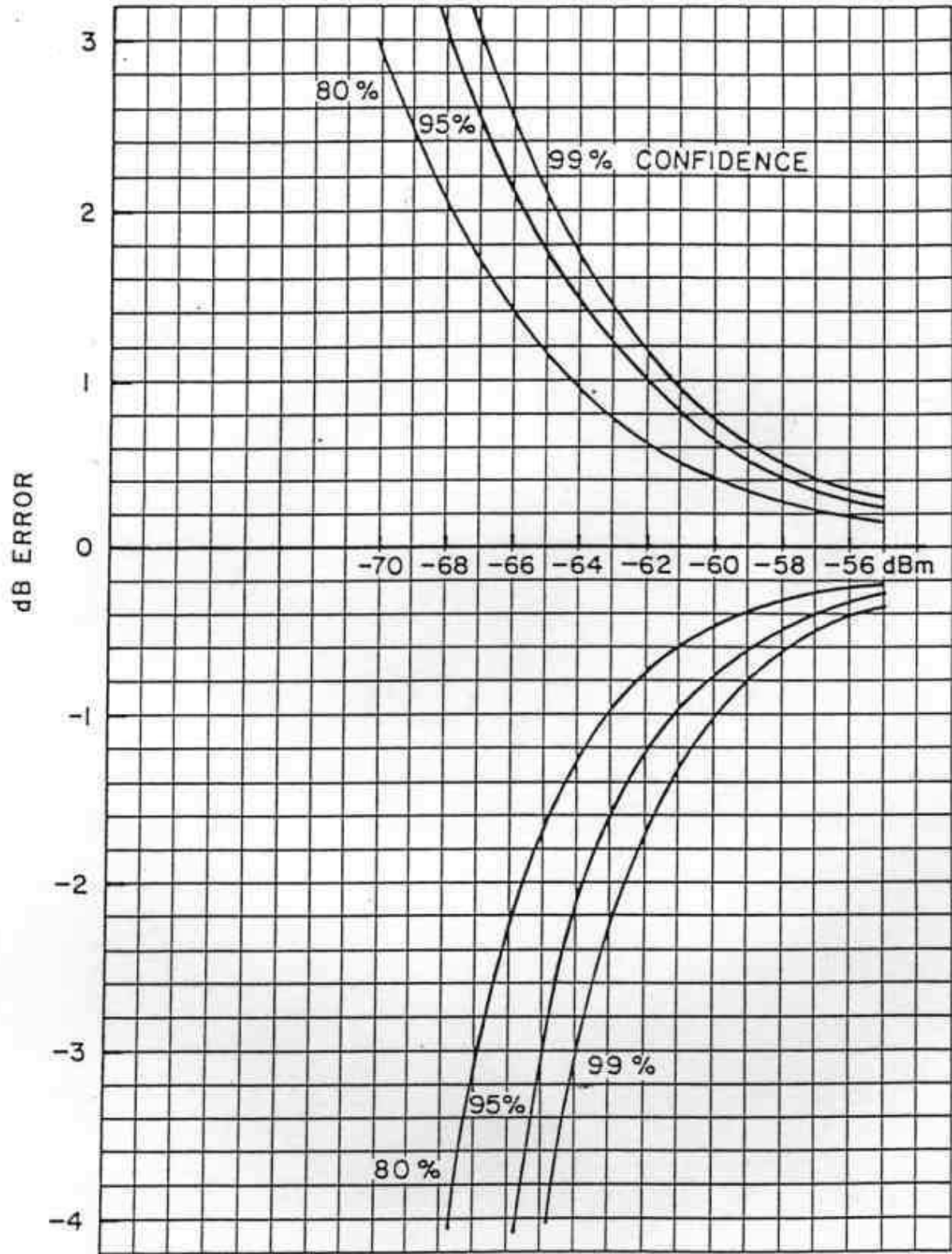
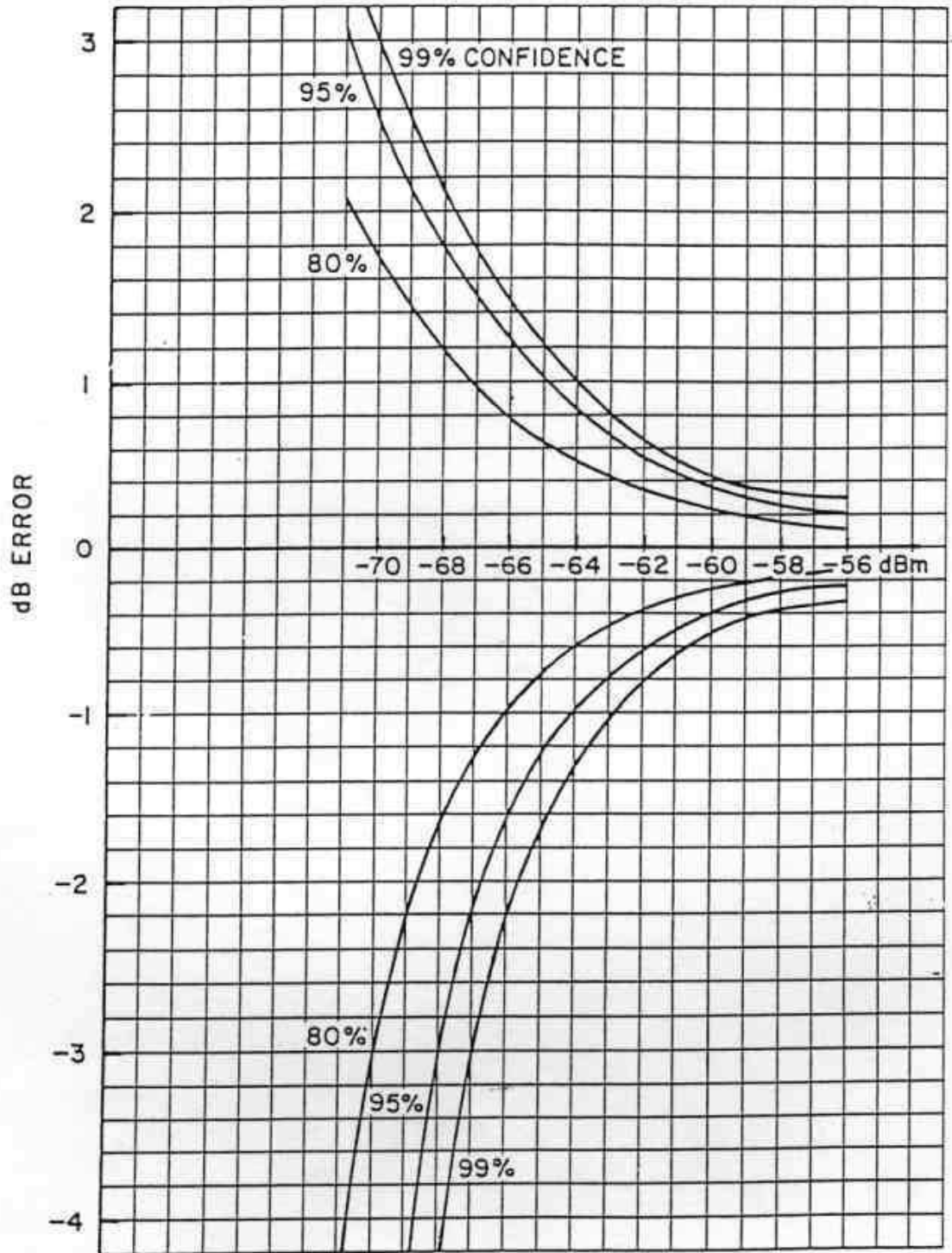

Figure 4-7. Probability of Falling within an Error Band



83157000A

Figure 4-8. Confidence Curves, 51013 Sensor with 2.8 Second Filter



83157100A

Figure 4-9. Confidence Curves, 51013 Sensor with 10 Second Filter

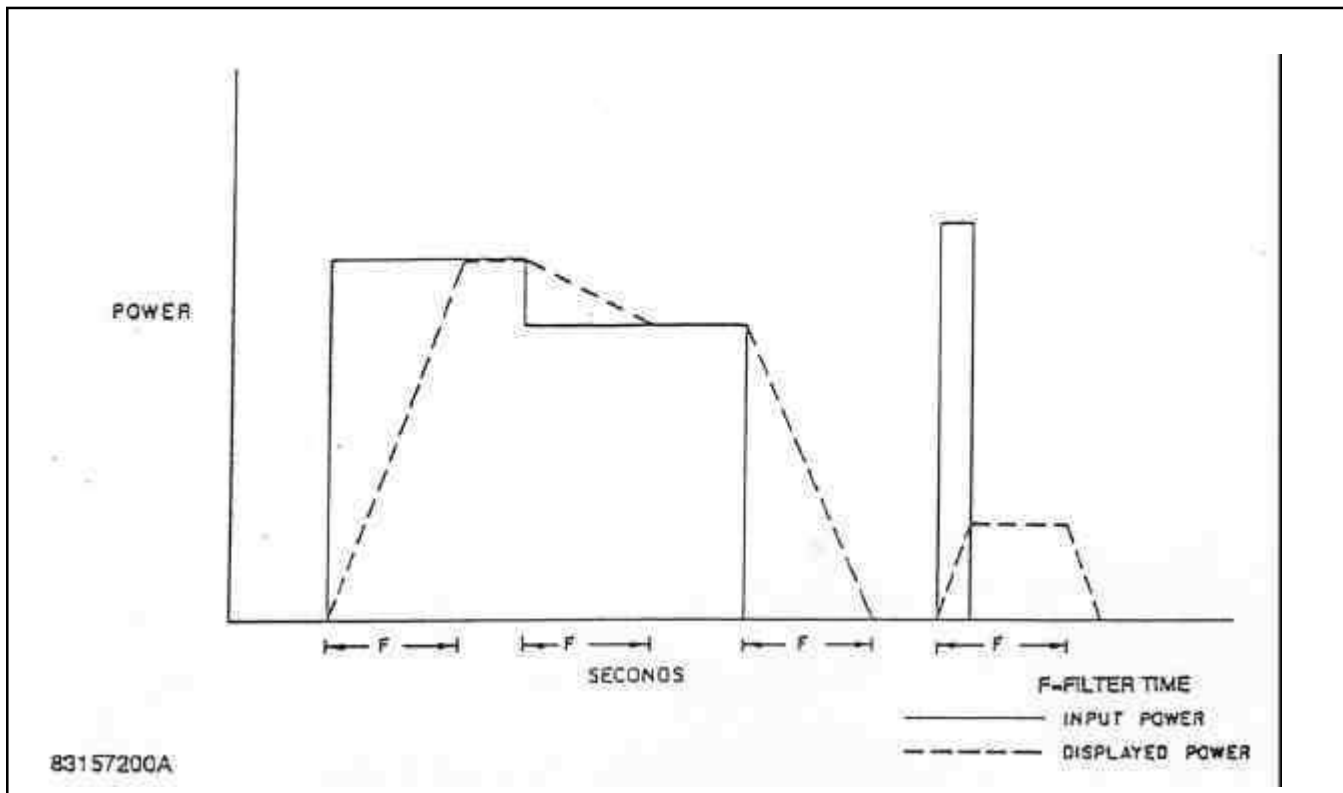

**Figure 4-10. Integration of Power**

**4-40. HIGH FREQUENCY ACCURACY.**

**4-41.** Power measurements, particularly at high frequencies, have a number of uncertainties which generally arise from imperfect SWRs. If all power sources and power meters had impedances that were resistive and equal to  $Z_0$  (the characteristic impedance of the measuring system), most problems would disappear. The incident, dissipated, and maximum available powers would all be equal, and the indicated power would differ only by the inefficiency of the power sensor in converting all dissipated power to indicated power. Tuning eliminates most of the SWR effects, but is cumbersome and is therefore seldom done. The use of attenuator pads can mask imperfect SWRs, as can the use of a directional coupler to level the source and reduce its reflection coefficient to a value equal to the directivity factor of the directional coupler. Boonton 51015 and 51033 power sensors have precision, built-in attenuators which improve the SWR over that of other power sensors.

**4-42.** When the complex coefficients of both an imperfect source and a power sensor are not known, but the maximum actual SWRs of both are known, the maximum positive and negative uncertainties of the measured power,  $P_m$ , can be determined from Figure 4-12. For example, if the SWR of the source is known to be 1.2 and the SWR of the power sensor is 1.25, the uncertainty derived from Figure 4-12 is 2%.

**4-43. WAVEFORM SENSITIVITY.**

**4-44.** Thermal sensors are insensitive to the waveform because they average RF power over many tens of milliseconds. Modulated signals, non-sinusoidal waveforms, and even pulses can be detected without distortion of the measurement. Thermal sensors are referred to as RMS responding.

**4-45.** Diode sensors are also RMS responding below about -20 dBm (-10 dBm and 0 dBm for attenuated models 51015 and 51033). This response characteristic is obtained because the sensors are dual diode types, and diodes respond in square-law fashion at low and medium levels. This is not an approximation, but rather an inherent effect. This effect results from the fact that the diodes do not turn on and off as switches, but behave as signal dependent resistors instead. Even with no signal input, the diodes have a finite conductance, and this conductance is modulated on a cycle by cycle basis to give a net DC offset proportional to the power.

**4-46.** The square-law response can be seen in Figure 4-13, where a 100% amplitude modulated signal is shown to have virtually no effect on the measured power at low levels. Of course, frequency modulated and phase modulated signals can be measured at any level, since the envelope of these modulated signals is flat. Frequency shift keyed (FSK) and quadrature modulated signals also have flat envelopes and can be measured at any power level.

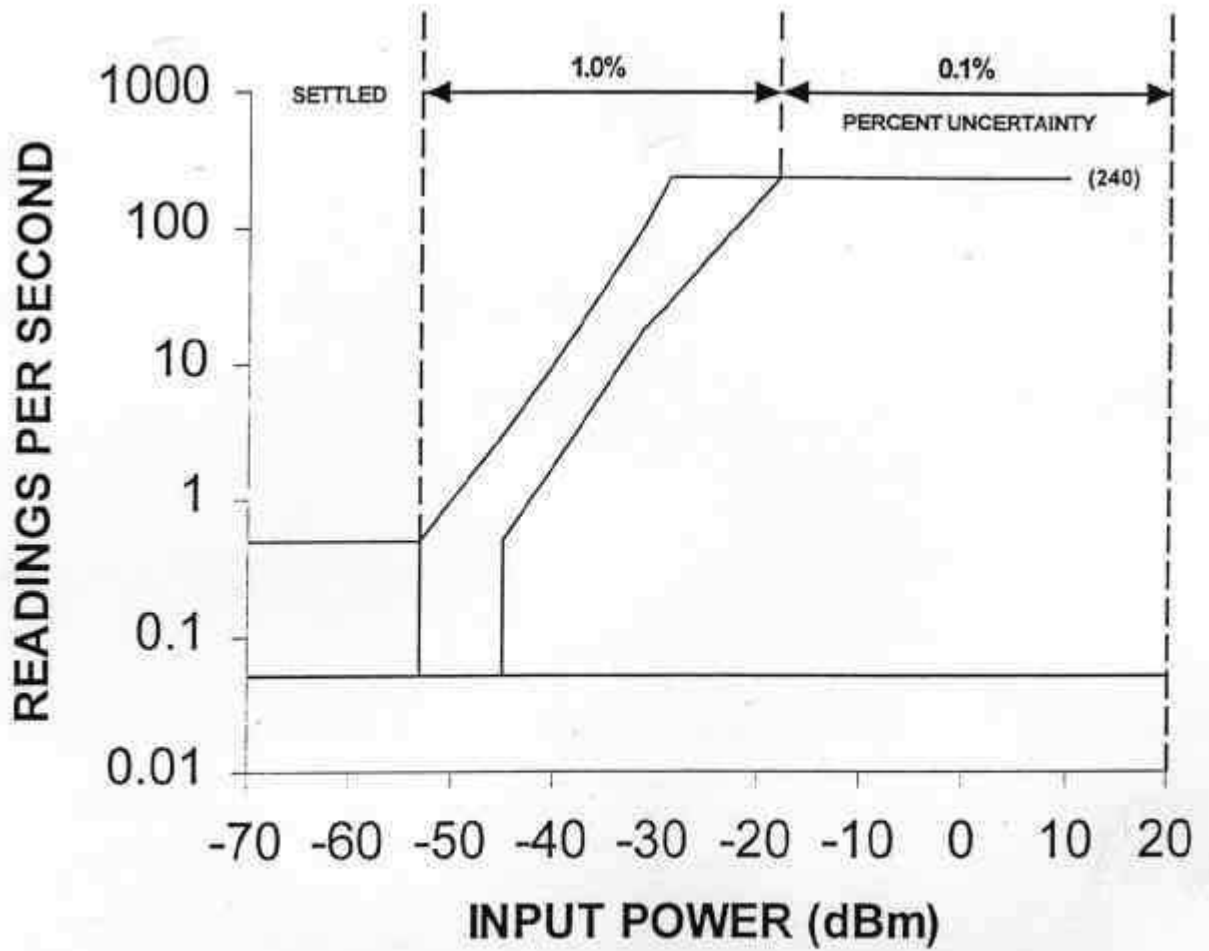

Fast mode measurement uncertainty due to settling time and noise as a function of the measurement rate in readings per second using optimal filter settings at various power levels.

Figure 4-11. Fast Mode Sampling Rate

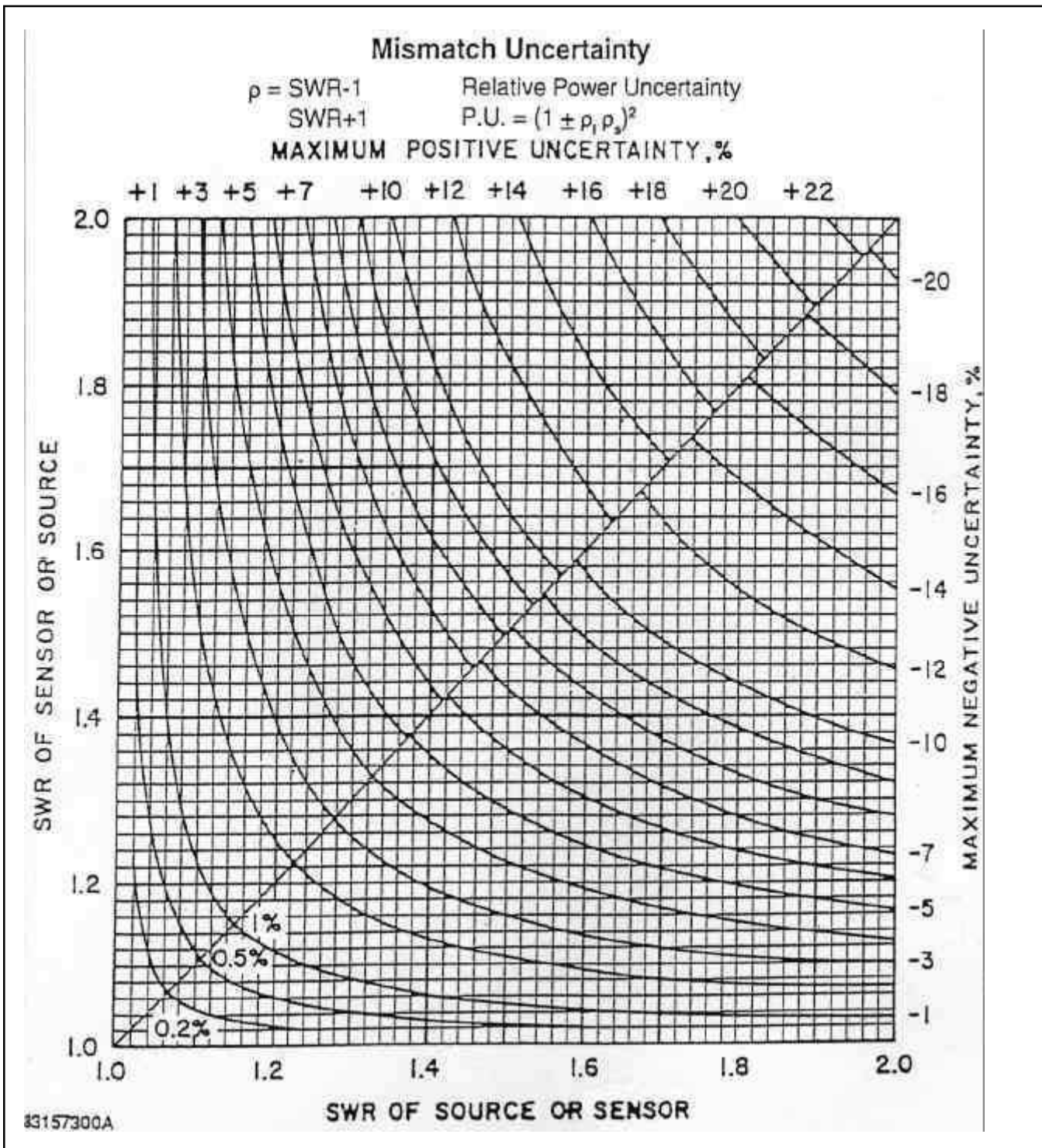

Figure 4-12. Mismatch Uncertainties Chart

4-47. At higher power levels (above approximately -10 dBm for the 51013 sensor), the diodes operate as peak detectors. The Model 4230A is software calibrated to calculate the RF power based on a shaping transfer function (RF to DC) for each sensor type. However, only measurements of RF signals with flat envelopes (CW, FM, PM, FSK, quadrature, etc.) are valid in this region and in

the transition region from -20 dBm to -10 dBm.

A special provision is made for the case of rectangular pulses where the duty cycle (on-time percentage) is known and the top level power of the pulse (pulse power) is to be measured. The duty cycle in percent is set into the DUTY entry in the CHANNELS menu. For example, if the signal consists of pulses with a duty cycle of 25%, set



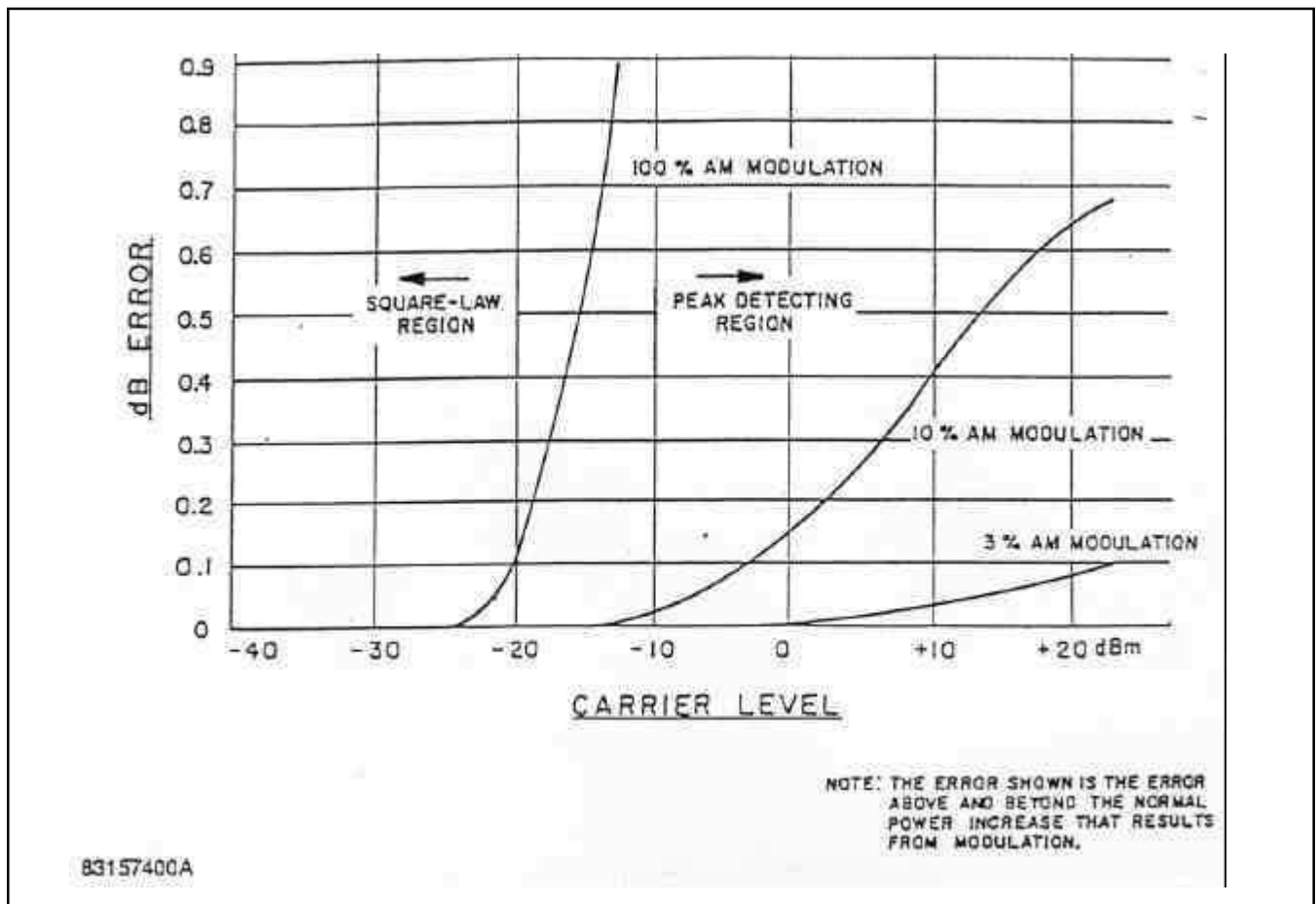

**Figure 4-13. Error Due to AM Modulation (51013 Diode Sensor)**

Only the display is affected by the duty cycle calculation. The measurement process is subject to the same criteria discussed above. For thermal sensor no correction is needed for level. However, pulse periods on the order of tens of milliseconds may result in unstable readings because of inadequate averaging. If the filter time constant is too short, it can be increased by use of the AVG function and menu.

For diode sensors, the RMS power region extends up to -30 dBm with a gradual change to peak voltage response. For accurate pulse power measurement, the power meter should read an average power of -30 dBm or less. This is the power indication when the duty cycle is set to 100%. Somewhat useful measurements can be made up to -20 dBm average power, but the uncertainty will typically be at least  $\pm 1$ dB.

Extra care should be taken when using the pulse power feature to avoid overload damage to power sensors. Pulses with small duty cycle have a very large peak to average power ratio. The average responding power meter has a small indicated power, but the peak signal at the sensor diode or thermal element may easily exceed the maximum ratings.

**4-48. CHART RECORDER OPERATION.**

**4-49.** The chart recorder output is a DC voltage from 0 to 10 volts. In the Watts mode, the output voltage is equal to the

digits displayed on the main data display divided by 1100. In the dBm or dB<sub>r</sub> modes, the output voltage is directly proportional to the level of the RF signal being measured. 0 dBm is at 8.0 volts with a sensitivity of 1.0 volt/10 dB overrange of the sensor. The output impedance is 9.06 kilohms, which gives the user the option of loading it with 1 kilohm, thereby reducing the full scale output to 1 volt. The normal 12-bit resolution is still maintained with this method. With a 1 megohm load, the circuit is essentially open and the error is small. Absolute accuracy is  $\pm 3\%$ .

**4-50. BARGRAPH OPERATION.**

**4-51.** The meter presents the power proportionally in the following manner.

**4-52. Watts Mode.** The meter follows the digital display as a percentage of the full scale. The bar graph consists of 100 segments resulting in a 1% resolution. A main data display of  $1100.0 \mu\text{W}$  drives the meter to 100 percent of full scale while a display of  $561.0 \mu\text{W}$  drives the meter to 51 percent of full scale. The meter reads full scale at 10 dB increments.

**4-53. dBm Mode.** The meter follows the digital display as a percentage of the full scale. The bar graph consists of 100 segments resulting in a resolution of 0.1 dB/segment. A main

Section IV  
Application Notes

DUTY to 25. This will add 6 dB to the displayed power and turn on the "Pk" indicator following the units.

data display of 0.00 dBm (or any 10 dB increment) drives the bar graph to zero percent of full scale while 5.00 dBm and 9.99 dBm drives the meter to 45 percent and 90 percent of full scale respectively. A value of -7 dBm would drive the meter to 27 percent of full scale while a value of -2 dBm would drive the meter to 72 percent of full scale.

**4-54. dBr Mode.** Selecting the dBr mode positions the bar graph to 50 percent of full scale when the digital display reads 0 dBr. The analog meter thereafter reads 100 percent of full scale at +5 dBr or more and zero percent of full scale at -5dBr or less.

**4-55. REMOTE(GPIB)OPERATION.**

**4-56. Introduction.** If the Model 4230A is equipped with the IEEE-488 option, the instrument can be operated remotely through an IEEE-488 interface. The IEEE-488 is a hardware standard which describes the communication and handshaking across the 8-bit parallel bus between a bus controller and up to 15 instruments.

**4-57.** The Model 4230A IEEE-488 capabilities are as follows:

|     |                   |  |
|-----|-------------------|--|
| C0  | NOCONTROLLER      | Capability                                   |
| SH1 | SOURCEHANDSHAKE   | Complete capability                          |
| AH1 | ACCEPTORHANDSHAKE | Complete capability                          |
| RL1 | REMOTELocal       | Complete capability                          |
| DC1 | DEVICECLEAR       | Complete capability                          |
| DT1 | DEVICETRIGGER     | Complete capability                          |
| RL1 | REMOTELocal       | Complete capability                          |
| DC1 | DEVICECLEAR       | Complete capability                          |
| DT1 | DEVICETRIGGER     | Complete capability                          |
| PP0 | PARALLEL POLL     | No capability                                |
| TE0 | EXTENDED TALKER   | No capability                                |
| T6  | BASICTALKER       | Complete capability except for talker only   |
| LE0 | EXTENDED LISTENER | No capability                                |
| L4  | BASICLISTENER     | Complete capability except for listener only |
| DMA |                   | Not supported                                |

**4-58. Local Operation.** This is the front panel operation of the instrument. The instrument initializes to the local mode on bus power on, and the remote mode becomes active only when the instrument is remote addressed by the bus controller. Once in the remote mode, the instrument can be returned to the local mode in any of three ways: by a GTL(go to local) command from

the bus controller, by turning off power to the instrument, or by pressing the front panel <Menu> key. The third method can be disabled by a local lockout (LLO) command issued by the bus controller.

**4-59. Remote Operation.** In the remote mode, all front panel key closures are ignored except for the <Menu> key (which may also be disabled by a LLO command from the bus controller). When the instrument is in the remote mode, the front panel REM annunciator is activated.

**4-60. Bus Address.** The IEEE-488 listen/talk address (MLTA) of the instrument can only be altered from the MENU-Setup-IEEE menu. Refer to paragraph 3-20.

**4-61. Terminating Characters.** To inform the instrument that a message has been completed, the bus controller must end all messages with a terminating character or EOI control signal. The Model 4230A can be programmed for several combinations of terminating characters as required by the controller employed. Selection of terminating characters is accomplished via the MENU-Setup-IEEE menu. There the instrument can be programmed for individual end of string characters in both listener and talker modes as well as independently enabling the end or initiate control signal.

**4-62. Listen Operation.** The instrument may be addressed as a listener without regard for remote or local mode. When the listener state is set by the bus controller, the instrument will receive bytes over the bus and place them in its input buffer. For listen operation, the input buffer is 150 characters long. Only one message can be entered into the input buffer at a time. A second message cannot be sent until the instrument has processed the previous message.

**4-63. Talk Operation.** When the instrument is requested to talk, the instrument response will depend on how it has been set up. The setup is either through talk modes or talk array commands. Talk modes are associated with making measurements; talk array commands are associated with the downloading of calibration data and instrument states. Refer to paragraph 4-73 for setup of the talk mode.

**4-64.** Only one instrument at a time can be addressed to talk, but many instruments can be addressed to listen simultaneously. When the Model 4230A is in the talk mode, the front panel TLK annunciator is illuminated. The format for each talk message is different and is explained in the paragraphs that follow.

**4-65. IEEE-488 Command Support.** The Model 4230A supports the following standard IEEE-488 commands:

a. Interface Clear Command. The interface clear (IFC) command forces all devices on the bus to clear their interfaces, and the bus to an initialized state, clearing the error condition. This command can only be issued by the bus controller in charge. The Model 4230A responds by clearing

the interface.

b. Device Clear. For this instrument, the device clear (DCL) command operates the same way as the IFC command described above.

c. Group Execute Trigger. The group execute trigger (GET) command allows the bus controller to issue a trigger to all instruments on the bus simultaneously. The Model 4230A will save the current reading at the time of the GET command and return it at the time of the next talk message mode. This is in essence a bus latch. The instrument must be set to one of its trigger modes. See paragraph 4-116.

d. SRQ. The service request (SRQ) allows an instrument to inform the bus controller that some special event has occurred. The instrument then expects the bus controller to

perform a serial poll to determine what event has occurred. Events that generate service requests include instrument error, measurement error, measurement is ready, and zeroing or calibration is completed. When the instrument SRQ is active, the front panel SRQ annunciator is illuminated.

e. Serial Poll. The serial poll (SP) command on the bus allows the bus controller to check the SRQ status byte of each instrument to determine which instrument is requesting service. The byte returned by the Model 4230A is composed of multiple bits that represent different status and error conditions. These conditions are individually maskable, as shown in Table 4-7.

f. Parallel Poll. The parallel poll (PP) command is not supported.

**4-66. Number Formatting.** Number formatting is shown

**TABLE 4-1. LISTEN PARAMETER COMMANDS**

| Mnemonic | Function and Limits  | Description   | Parameter No.   |
|----------|--|---|-----------------|
| CH#      | Channel select<br># 1, 2   | Sets channel  | 12,N            |
| DY#      | Duty cycle<br># 0.01 to 100.00 in 0.01 steps                                       | Sets duty cycle percent (sets pulse power mode when not=100%)                                     | 13,N            |
| FL#      | Filter time select<br># 0 to 20.00 in 0.05 steps                                   | Corresponds to AVG-Sec data entry (AUTO FILTER MODE when set to 0) (see FA command)               | 3,N             |
| FD#      | dB calibration factor<br># -3.00 to 3.00 in 0.01 steps                             | Changes the frequency CAL FACTOR to # . Original CAL FACTOR is restored by entering the frequency | 10,N            |
| FR#      | Frequency select<br># 0 - 100.00   | Corresponds to FREQ-GHz data entry  | 4, N            |
| LH#      | High limit select<br># -99.99 to 99.99 in 0.01 steps (or 0 to 99999 in Watts mode) | Corresponds to Menu -Channels-Hi Lmt data entry   | 14, N           |
| LL#      | Low limit select<br># -99.99 to 99.99 to 0.01 steps (or 0 to 99999 in Watts mode)  | Corresponds to Menu-Channels-Lo Lmt data entry  | 15, N           |
| LM#      | Alarm select<br># 0 disable<br># 1 enable  | Corresponds to Menu-Channels-Alarm command  | 17, N           |
| OS#      | Offset select<br># -99.99 to 99.99 in 0.01 steps                                   | Corresponds to Menu-Channels-Offset data entry  | 16, N           |
| RS#      | Range select<br># 0 to 6   | Corresponds to Menu-Channels-Range selection  | 5, N (-1 = RA)* |
| SM#      | SRQ Mask<br># 0 - 255  | Corresponds to the Menu-Setup-IEEE-SRQ Mask data entry  | 11, N           |
| SR#      | Set dBr reference<br># -99.99 to 99.99 in 0.01 steps                               | Corresponds to REF Level-dBm data entry with Mode=Set   | 6, N            |

**TABLE 4-1 LISTEN PARAMETER COMMANDS (Continued)**

| Mnemonic | Function and Limits  | Description                                | Parameter No. |
|----------|--|--|---------------|
| SS#      | Sensor data source<br># 1 - 6<br>Where:<br># 1 - 4 are internal tables<br># 5 is the sensor data adapter for channel 1<br># 6 is the sensor data adapter for channel 2 | Corresponds to Sensor-Ser# selection       | 1, N          |
| TM#      | Talk Mode<br># 0 to 6  | Sets talk mode for IEEE-488 bus operation. | 8, N          |

**TABLE 4-2. LISTEN ACTION COMMANDS**

| Mnemonic | Function         | Description  | Mnemonic | Function                  | Description  |
|----------|------------------|--|----------|---------------------------|--|
| CF       | Calibrator off   | Turns off 50 MHz calibrator  | MFD      | Measure Fast Dual         | Sets fast dual channels measurement mode             |
| CL       | Clear            | Clears error number and error  | MFS      | Measure Fast Single       | Sets fast single channel (CH1 only) measurement mode |
| CN       | Calibrator on    | Turns on 50 MHz calibrator   | MN       | Measure Normal (free run) | Sets normal free run measurement mode                |
| CP       | Calibrate        | Corresponds to Zero/CAL-CAL selection  | MS       | Measure Settled           | Sets settled measurement mode                        |
| DB       | dBm select       | Corresponds to Menu--Channel-Units-dBm selection   | TF       | Trigger Filtered          | Selects filtered trigger mode                        |
| DF       | Display off      | Turns off instrument display   | TFD      | Trigger Fast Dual         | Selects fast dual channels trigger mode              |
| DN       | Display on       | Turns on instrument display  | TFS      | Trigger Fast Single       | Selects fast single channel (CH1 only) trigger mode  |
| DR       | dBr select       | Corresponds to REF-Level-Mode equal to SET using the previous reference level                      | TN       | Trigger Normal            | Selects normal trigger mode                          |
| FA       | Auto filter      | Sets instrument to auto filter   | TR       | Bus trigger               | Bus trigger command                                  |
| LR       | Load Reference   | Loads the current measurement as the reference level. Corresponds to REF Level-Mode equal to LOAD. | TS       | Trigger Settled           | Selects settled trigger mode                         |
| MF       | Measure Filtered | Sets filtered measurement Mode   | ZR       | Instrument zero           | Corresponds to Zero/CAL-ZERO selection               |
|          |                  |  | ?ID      | Talk instrument ID        | Calls up instrument identification                   |
|          |                  |  | *IDN?    | Talk instrument ID        | Calls up instrument identification                   |

**TABLE 4-3. LISTEN ARRAY PARAMETER COMMANDS**

| Mnemonic | Function                                  | Description             |
|----------|---|-------------------------|
| SI       | Sensor ac calibration data in             | Refer to paragraph 4-90 |
| FI       | Sensor high frequency calibration data in | Refer to paragraph 4-98 |

**TABLE 4-4. TALK ARRAY COMMANDS**

| Mnemonic | Function                                   | Description              |
|----------|--|--------------------------|
| SO       | Sensor calibration data out                | Refer to paragraph 4-94  |
| FO       | Sensor high frequency calibration data out | Refer to paragraph 4-102 |

**TABLE 4-5. TALK MODES**

| Talk Mode | Description                     |
|-----------|---------------------------------|
| 0         | Talk measurement floating point |
| 1         | Talk measurement with units     |
| 2         | Talk error                      |
| 3         | Talk both channels              |
| 4         | Talk channel status             |
| 5         | Talk instrument status          |
| 6         | Talk parameter                  |
| 7         | Talk array                      |
| 8         | Not used                        |

for each of the commands in the paragraphs that follow, but general rules are as follows:

- a. Fixed or floating formats are accepted.
- b. The optional + or - may precede the mantissa and/ or the exponent.
- c. An optional decimal point may appear at any position within the mantissa. A decimal point in the exponent is ignored.
- d. The optional "E" for exponent may be upper or lower case.
- e. All ASCII characters below and including ";" (3Bh) are considered command delimiters. The ASCII characters " " (20h), ",", ";" (3Bh), and ":" (3Ah) are considered numeric delimiters.

**4-67. String Format.** String formatting is as follows:

- a. The programming sequence is in natural order, that is, a function mnemonic is sent first, followed by the argument value (parameter), if applicable.
- b. The data strings sent to the instrument are not case

sensitive. This means lower case and upper case are the same.

c. Spurious numbers occurring in the listen string are ignored.

d. All block modes have formatted data arrays or ASCII strings. See Tables 4-3 and 4-4 for commands and paragraphs 4-88 thru 4-112 for format.

**4-68. Listen Parameter Commands.** Listen parameter commands are listed in Table 4-1. These are commands, received by the instrument, that expect one numerical value to follow for setting a particular operating condition. Except as noted in the table, these commands correspond to specific front panel commands. Key commands correspond to single keystrokes; non-key commands are submodes or menu types of data entry.

**4-69.** The numeric value (parameter) can be sent in the next listen string if the listen parameter command was the last value of the previous string. If, for any reason, a command is sent without a parameter following the command, the CL command can be used to clear the active command, or a new command can be used. The parameter number listed in Table 4-1 is the number returned when the talk parameter mode (talk mode 6) is exercised.

**4-70. Listen Action Commands.** Listen action commands are listed in Table 4-2. These commands initiate an action without any parameters being sent.

**4-71. Listen Array Commands.** Listen array commands listed in Table 4-3 transfer arrays of data (more than one parameter) to the instrument. Sensor data and DC calibration data are typical data. The data array is formatted as in paragraphs 4-93, 4-100, and 4-110. The actual amount of data depends on the specific command being used. Listen

array commands are only operable over the bus, and have no application from the front panel.

**4-72.** The talk array commands listed in Table 4-4 build a talk string in the talk buffer for transmission. Not for general purpose measurement (the talk modes are used for that), the talk array commands are used for transmitting arrays of data (more than one parameter), such as sensor data and DC calibration data. The buffer contents are discarded at the time of the next instrument talk request. These commands automatically change the talk mode to talk mode 7, then reset the Model 4230A to its previously selected talk mode. This is the only time that the instrument uses the talk buffer or talk array mode. Talk array commands are operable only over the bus.

**4-73. Talk Modes.** When the Model 4230A is requested to talk, it responds according to how it has been set up. The talk setup is either through talk array commands or talk modes. Talk modes are associated with making measurements; talk array commands are associated with downloading of calibration data and instrument states. The talk modes are described in the following paragraphs.

**4-74.** The Model 4230A supports eight talk modes of operation, as listed in Table 4-5. Once the talk mode has been set, the bus controller need only tell the Model 4230A to talk and it will respond according to the talk mode.

**4-75.** Talk modes 0 through 6 can be set directly by use of the talk mode (TM) command. For these modes, the instrument will remain in the selected mode until the talk mode is changed or until a talk array command is received. Talk mode 7 is a temporary talk mode that is automatically enabled in response to a talk array command. This mode cannot be set by the bus controller directly. This temporary talk mode is disabled when the talk array operation is complete.

**4-76.** The default condition for the talk mode is 0. The talk modes are described individually in paragraphs 4-77 through 4-86.

**4-77. Talk Mode 0 (Talk Measurement Floating Point).** The talk mode 0 format is as follows:

#1,#2

where:

#1 is the error flag (1 = error, data invalid).

#2 is the measurement in floating point notation in the units selected (dBm, dBr, or milliwatts). In watts mode, the unit is fixed at mW.

Examples:

0,0.00E00 - No error, power is 0.00 dBm

1,0 - Under range error at -75.00 dBm

0,98.9E-6 - No error, power is 98.9 nW

**4-78. Talk Mode 1 (Talk Measurement with Units).** The format for talk mode 1 is as follows:

#1,\$1

where:

#1 is the error flag (1 = error).

\$1 is the measurement. The format is fixed point followed immediately by a three character string that indicates the unit of measurement. Possible units are "dBm", "dBr", "nW", "uW", "mW", and "W", "kW", and "MW". If needed, the string can be parsed externally into a number and a three character message.

Examples:

0,0.00dBm - No error at 0.00 dBm

1,0dBm - Under range error at -75.00 dBm

0,98.9uW - No error at 98.9 microwatts

**4-79. Talk Mode 2 (Talk Error).** The talk mode 2 format is as follows:

#1,#2,#3

where:

#1 is the instrument error number. A 0 will always be reported in this position.

#2 is the measurement error, from 0 to 99. A 0 indicates no error. Refer to Table 4-6 for error messages.

#3 is the channel reporting errors. A 1 is reported for channel 1 and a 2 is reported for channel 2.

Execution of this talk mode automatically clears the measurement error after it has been reported. If more than one error occurs, the instrument will indicate the first one that occurred.

Examples:

0,0,1 - No error is reported for channel 1

0,3,2 - Power level is underrange for channel 2

**4-80. Talk Mode 3 (Talk Both Channels).** The talk mode 3 format is as follows:

#1, #2, #3, #4

where:

#1 is the error flag for channel 1

(1 = error, data invalid)

#2 is the measurement in floating point notation in

the units selected (dBm, dBr, mW). In watts mode, the unit is fixed at mW.

#3 is the error flag for channel 2 (1 = error, data invalid)

#4 is the measurement in floating point notation in the units selected (dBm, dBr, mW). In watts mode, the unit is fixed at mW.

Examples:

0,0.00E00,0,1.00E00 - No error, power is 0.00 dBm on channel 1 and 1.00 dBm on channel 2.

1,0,0,1.00E00 - Channel 1 under range at -75 dBm and 1.00 dBm on channel 2.

0,90.1E-6,0,1.00E1 - No error, power is 90.1 nW on channel 1 and 10.00 dBm on channel 2.

**4-81. Talk Mode 4 (Talk with Channel Status).** The format for talk mode 4 is as follows:

#1,#2,#3,#4,#5,#6,#7

where:

#1 is always 1 in the 4230A

#2 is always 1 in the 4230A

#3 is the measurement units that the channel is set;

0 Power in watts, milliwatts, microwatts, or nanowatts

1 Power in dBm

2 Power in dBr

#4 indicates the trigger mode of operation;

0 Measure Normal (also known as free-run)

1 Measure Filtered

2 Measure Settled

3 Trigger Normal

4 Trigger Filtered

5 Trigger Settled

6 Reserved

7 Measured Fast Single

8 Measured Fast Dual

9 Reserved

10 Trigger Fast Single

11 Trigger Fast Dual

#5 is always 0 in the 4230A

#6 is always 0 in the 4230A

#7 is the software version number.

**4-82. Talk Mode 5 (Talk Instrument Status).** The format for talk mode 5 is as follows:

#1,#2,#3,#4

where:

#1 is always 0 in the 4230A

#2 indicates calibrator status;

0 off

1 on

#3 is always 0 in the 4230A

#4 is always 0 in the 4230A

**4-83. Talk Mode 6 (Talk Parameter).** The format for talk mode 6 is as follows:

#1,#2

where:

#1 is the active parameter number (0 = no parameter selected).

#2 is the active parameter value, for example “frequency”. The units are defaulted.

**4-84.** This command returns two numbers which describe the current “opened” or selected parameter in the instrument and its value. For example, the frequency to which the instrument is set can be read over the bus. To read a parameter, it must be “opened” first as described in paragraph 4-85. A parameter in the Model 4230A is defined as a front panel or bus command that allows or requires a numerical value to be entered into it. The parameters and parameter numbers are listed in Table 4-1. The data sent over the bus is the same as the data that would appear on the instrument's displays when the parameter is selected.

**4-85.** To use this talk mode, the instrument is first placed in talk mode 6 and a parameter is then opened (made active) by sending the bus command. No numeric value should follow and the clear command should not be used. Then, while the parameter is active, a talk command is issued to the instrument and the data for that parameter is sent out on the bus. A parameter can be deactivated by simply entering a number or sending another command.

Examples:

0,0 No parameter is active and the second value should be ignored

10,-3.00 The dB cal factor is currently set to -3.00 dB.

5,1 Range 1 is set.

4,1.23 The frequency is set to 1.23 GHz

**TABLE 4-6. ERROR MESSAGES**

| Error Message Code | Description  |
|--------------------|--|
| 0                  | No Errors  |
| 1                  | Number entry out of range for parameter set.   |
| 2                  | Unused   |
| 3                  | -LO- indication on display. Is caused by<br>a. Power level below amount allowed in dBm display during autorange<br>b. Power level below amount allowed for range set in watts or dBm display.                                    |
| 4                  | -HI- indication on display. Is caused by<br>a. Power level above amount allowed in dBm display during autorange.<br>b. Power level above amount allowed for range set in watts or dBm display.                                   |
| 5                  | Occurs when input channel attempts to autorange below the range 0. Caused by incorrect zeroing of channel or a sensor which is damaged or not connected.   |
| 6                  | Unable to zero instrument because power is applied to the sensor, the sensor is damaged, or the sensor is not connected.   |
| 7 thru 23          | Unused   |
| 24                 | Frequency out of range of entry. This error applies to sensors not calibrated at the frequency entered.  |
| 25 thru 29         | Unused   |
| 30                 | The message string has exceeded 150 characters. All commands sent are ignored.   |
| 31                 | The command string sent has not been recognized by the instrument. If more than one command has been sent, the commands occurring before the unrecognized command have been executed, while subsequent commands will be ignored. |
| 32 thru 38         | Unused   |
| 39                 | Calibration attempted when power exceeds $\pm 3$ dB of the 0 dBm reference, or when calibration is attempted at $\pm 3$ dB from -10 dBm, +10 dBm or +20 dBm.   |

**4-86. Talk Mode 7 (Talk Array).** Each of the different talk array commands has a different format. (Refer to the applicable section of paragraph 4-75.) This talk mode is not directly settable by the bus controller; it is set automatically by execution of one of the talk array commands. Talk mode 7 builds a data string in the talk buffer for a one time transmission. It is used to send an array of numerical data or a string of character data, such as sensor and/or calibration data. Once executed, this mode is automatically cleared to its previously selected value or default condition.

**4-87. IEEE-488 BUS ONLY COMMANDS.**

**4-88. General.** The following paragraphs cover commands that are available only under remote control on the bus.

**4-89. Talk Mode(TM) Command.** The talk mode command is used to change to a selected talk mode. The range of data for this command is from 0 to 6. Talk mode 7 can only be set indirectly by execution of a talk array command. The talk mode command is classified as a listen parameter command.

Example:

TM1 - Set talk mode 1 which is talk measurement with units.

**4-90. SI Command.** Used in conjunction with the SO command, this command is used to send a portion of the sensor calibration data to the Model 4230A in the form of an array of numeric data. In this way, sensor data can be transferred from one instrument to another, or stored on a disk.

**4-91.** The data is the sensor model, sensor S/N, and the 14 point linearity data (AC calibration data) for a selected sensor. This command complements the SO command over the bus, and the SO command would normally be the source of the data string for this command. The SI command is classified as a listen array command.

**4-92.** In addition to the 14 point linearity data, each sensor has high frequency calibration data, which is loaded with the FI command. (See paragraph 4-98.)

**4-93.** The format for the SI command is as follows:



SI sensor model, sensor serial number,  
U0,U1,U2,U3,U4,U5,U6,D0,D1,D2,D3,D4,D5,D6

where:

Sensor model is a number in the form 51XXX, where XXX is a three digit number sent to the instrument. Sensors must be resident in the instrument firmware.

Sensor serial number is from 0 to 99999, representing the last 5 digits of the sensor's full serial number.

U0 through U6 are the upscale gain factors (1000 to 9999, nominally 5000).

D0 through D6 are the downscale factors (-999 to +999).

Each numeric value must be separated by a valid delimiter.

Example:

SI13,1234,5012,5003,5032,5013,4995,5005,4891,  
-20,-21,2,-3,-14,15,6

**4-94. SO Command.** Used in conjunction with the SI command, this command is used to send sensor 14 point linearity data out to the bus controller. (Refer to the SI command description for the general use of these commands.) Sensor data also includes high frequency calibration data, but this data is handled with the FI command. See paragraph 4-98.

**4-95.** When executed, the SO command instructs the instrument to build an array of numeric data in the talk buffer for transmission by the next talk request. The array consists of sensor model, sensor S/N, and numeric data representing the 14 point linearity data (AC calibration data) for a selected sensor. This command complements the SI command over the bus, and the SI command would normally be the destination of the data string of this command. The SO command is classified as a talk array command.

**4-96.** The talk mode is set temporarily to talk mode 7 (talk array) when this command is executed. After execution, the talk mode is reset to the previous setting. A clear command will also reset the talk mode.

**4-97.** Formats are as follows:

- a. To the instrument in a listen string: SO
- b. From the instrument in the next talk string: sensor model, sensor serial number, U1,U2,U3,U4,U5,U6,D0,D1,D2,D3,D4,D5,D6, where the format descriptions are the same as in paragraph 4-93. Each numeric value must be separated by a valid delimiter.

Example:

To the instrument in a listen string: SO

From the instrument in the next talk string:  
51013,1234,5023,5001,5012,5010,4997,5005,  
5003,10,13,-2,-23,14,-15,6

**4-98. FI Command.** Used in conjunction with the FO command, this command is used to send sensor high frequency calibration data to the Model 4230A for a selected sensor in the form of an array. In this way, sensor data can be transferred from one instrument to another, or stored on a disk. In addition to the high frequency calibration data, there is 14 point calibration data for the sensor, but this is handled by the SI command.

**4-99.** The data is for a selected sensor. This command complements the FO command over the bus, and the FO command would normally be the source of the data string for this command. This command is classified as a listen array command. Data is loaded in blocks from 1 to 12 pairs.

**4-100.** The command format is as follows:

FI n, FRn, CRn, FRn+1, CFn+1, .... FRN+11, CFn+11

where:

n is the table number pointer, from 0 to 59.

FRn is the first frequency of this group, from 0.00 to 100 GHz in 0.01 GHz increments. It is sensor dependent.

CFn is the first dB cal factor for this group, from -3.00 to +3.00 dB in 0.01 dB increments.

Each numeric value must be separated by a valid delimiter.

**4-101.** The total number of frequency points is limited to 60 for sensor tables 1 through 6. The table number pointer is the beginning location for the frequency/dB cal factor pairs. Frequency cal points must be in numerical order of frequency. Generally, the first point is at 0 GHz, with a cal factor of 0.

Example:

FI0,0.00,0.00,1.00,-0.05,2.00,-0.07,3.00,0.10,4.00,  
-0.06,5.00,-0.05,6.00,0.00,7.00,0.13,8.00,0.42,  
9.00,0.34,10.00,0.00,11.00,0.15,

FI12,12,.12,13,-.13,14,1.14,15,.85

**4-102. FO Command.** Used in conjunction with the FI command, this command is used to send sensor high frequency calibration data out to the controller. Refer to the FI command description for the general use of these commands. Data points are loaded in blocks of 12.

**4-103.** When executed, this command instructs the instrument to build an array of numeric data in the talk buffer for transmission by the next talk request. The array consists of numeric data representing the dB cal factor information for a selected sensor table. The FO command is classified as

**TABLE 4-7. SRQ MASKS - NATIVE MODE**

| Bit | Description  |
|-----|--|
| 0   | Set bit indicates LO LIMIT alarm in Channel 1  |
| 1   | Set bit indicates that a measurement error has occurred  |
| 2   | Set bit indicates that either a Trigger Filtered or Trigger Settled measurement is ready             |
| 3   | Set bit indicates that a CAL/Zeroing command is complete   |
| 4   | Set bit indicates HI LIMIT alarm in Channel 1  |
| 5   | Set bit indicates LO LIMIT alarm in Channel 2  |
| 6   | Set bit indicates that an SRQ is active; this is a summary bit used in serial poll, not a masked bit |
| 7   | Set bit indicates HI LIMIT alarm in Channel 2  |

a talk array command.

**4-104.** The talk mode is temporarily set to talk mode 7 (talk array) when this command is executed. After the command has been executed, the talk mode is reset to the previous setting. A clear command will also reset the talk mode.

**4-105.** The format for the FO command is as follows:

- a. To the instrument in the listen string: FO n
- b. From the instrument in the next talk string: FRn, CRn, FRn+1, CRn+1, ..., FRn+11, CRn+11

where:

n is the table number pointer, from 0 to 60.

FRn is the first frequency of this group, from 0.00 to 100 GHz in 0.01 GHz increments. It is sensor dependent.

CRn is the first dB cal factor for this group, from -3.00 to +3.00 dB in 0.01 dB increments.

Each numeric value will be separated by a comma.

**4-106.** Refer to the FI command for limitations on the pointer and starting frequencies, and for general use of this command.

Example:

Command sent to the instrument: FO 0

Numeric array built into the talk buffer:

0.00,0.00,1.00,-0.05,2.00,-0.07,3.00,-0.10,4.00,  
-0.06,5.00,-0.05,6.00,0.00,7.00,0.13,8.00,0.42,  
9.00,0.34,10.00,0.00,11.00,0.15

Command sent to the instrument: FO 3

Numeric array built into talk buffer:

3.00,-0.10,4.00,-0.06,5.00,-0.05,6.00,0.00,7.00,  
0.13,8.00,0.42,9.00,0.34,10.00,0.00,11.00,0.15,  
12.00,0.32,13.00,0.25,14.00,0.43

**4-107. DF Command.** This command is classified as a

listen action command. Its functions are to blank the front panel display for secure ATE applications and to speed up operations by reducing the number of tasks that have to be performed by the Model 4230A. When the display is turned off, the display hardware is still functional, but it is not updated for certain types of information.

**4-108. DN Command.** This command enables the front panel display, complementing the DF command. This command is classified as a listen action command.

**4-109. SM (SRQ Mask) Command.** This command is used to set the SRQ mask which selectively enables service requests generated by the Model 4230A. This command is classified as a listen parameter command. The range of numeric entry is from 0 to 255. The SRQ mask is logically ANDed with the SRQ sources to determine if an SRQ should be generated. The SRQ bit map is shown in Table 4-7. For more information on SRQ and the related serial poll, refer to paragraph 4-65.

Examples:

- SM 0 - Disable all service requests
- SM 2 - Enable SRQ only on measurement errors
- SM 8 - Enable service request only when a zeroing operation is complete

**4-110. MEASURED AND TRIGGERED OPERATION AND SETTLED READING.**

**4-111. General.** Five measurement modes and five triggered modes are available over the bus. They are:

- a. Measure Normal (also known as free-run)
- b. Measure Filtered
- c. Measure Settled
- d. Measure Fast Single Channel
- e. Measure Fast Dual Channels
- f. Trigger Normal
- g. Trigger Filtered

- h. Trigger Settled
- i. Trigger Fast Single Channel
- j. Trigger Fast Dual Channels

The instrument must be in remote bus operation to invoke these modes of operation. When in local operation, only measure normal is available. The five measurement modes are each self triggering (free running) while the triggered modes require a bus trigger command. The operation of each mode is modified by filter selection and range selection. See paragraphs 4-16 and 4-18. The modes are described below.

**4-112. Measure Normal (MN).** This is the mode to which the instrument initializes at power up when the local command is issued in bus operation or when returning from a calibration mode.

**4-113. Measure Filtered (MF).** In this mode, the front panel display is self triggered and continuously updated. In response to a step change in power of approximately 0.02 dB or an internal range change, the front panel displays the "——.——" (dashes) message until the digital filter time constant has elapsed. This mode guarantees that the reading is filtered by holding off the display of partially filtered readings.

**4-114. Measure Settled (MS).** In the MS mode, the front panel display is self-triggered and continuously updated. In response to a step change in power or an internal range change, the front panel displays the "——" (dashes) message until the settled condition occurs. The minimum time for a settled reading is twice the selected filter time constant. The maximum time is unlimited, because the settled condition may never occur for noisy signals or constantly varying signals. This mode should not be used in a data acquisition system because the unsettled condition may holdoff the GPIB indefinitely.

**4-115. Measure Fast Single (MFS).** The measure fast single channel mode of operation provides the instrument's fastest measurement response when addressed to talk over the IEEE bus. Measurements at a rate of 240 readings per second can be obtained (see Figure 4-11). This mode only applies to channel 1 and will disable channel 2 when executed. The fast hardware filter for channel 1 is employed.

**4-116. Measure Fast Dual (MFD).** The measure fast dual channel mode of operation provides the instrument's fastest measurement response for both channels when addressed to talk over the IEEE bus. Measurements at a rate of 120 readings per second for each channel can be obtained. In this mode, the fast hardware filters for channel 1 and channel 2 are employed.

**4-117. Trigger Normal (TN).** In this mode, the front panel displays the -TRIG- message until the 4230A is triggered by a bus command. The instrument continuously measures power as in the measure normal mode but does not display the

reading. When triggered, the instrument captures the most recent measurement and displays the reading until another trigger command changes the display. This mode provides a quick response to trigger and the capability to hold a reading until required. However, the user is required to assure stability of the reading at the time of trigger.

**4-118. Trigger Filtered (TF).** When entering this mode, the front panel displays the "-TRIG-" message. When a bus trigger command is received, the instrument begins the measure filtered mode. The 4230A displays the "-TRIG-" message until the digital filter time constant has elapsed. The instrument displays and holds the filtered reading until another bus trigger command is received. In this mode, the digital filter guarantees a filtered reading upon trigger and the capability to hold a reading until required.

**4-119. Trigger Settled (TS).** When this mode is entered, the front panel displays the "-TRIG-" message. The measure settled mode begins when a bus trigger command (GET) is received. The "-TRIG-" message will continue to be displayed until the settled condition occurs. The minimum time for a settled reading is twice the selected filter time constant. The maximum time is unlimited, because the settled condition may never occur for noisy signals or constantly varying signals. In a data acquisition system this mode should be used only in connection with a bus service request (SRQ) to signal the controller when the measurement is complete. This allows the user's program to limit the time allowed for settling and take appropriate action if it is not achieved. Otherwise, an unsettled condition may holdoff the GPIB indefinitely.

**4-120. Trigger Fast Single (TFS).** When the TFS command is executed, the front panel displays the "-TRIG-" message. Once a bus trigger command is received, the instrument begins the fast single channel measurement mode of operation. The "-TRIG-" message is displayed until the completion of the measurement. Triggered response times of 5 ms may be obtained (see Figure 4-11). This mode only applies to channel 1 and will disable channel 2 when executed. The fast hardware filter for channel 1 is employed.

**4-121. Trigger Fast Dual (TFD).** When the TFD command is executed, the front panel displays the "-TRIG-" message. Once a bus trigger command is received, the instrument begins the fast single channel measurement mode of operation. The "-TRIG-" message is displayed until the completion of the measurement. Triggered response times of 10 ms may be obtained. In this mode, the fast hardware filters for channel 1 and channel 2 are employed.

#### 4-122. IEEE PROGRAMMING EXAMPLES.

**4-123.** The following programming examples demonstrate, bus operation of the 4230A. The examples are written in a general format of BASIC and are not an example of any specific implementation of the language. The examples assume that the 4230A is the only instrument connected to the bus so that all commands address the 4230A.

Section IV  
Application Notes

**4-124.** In the examples, “INPUT” refers to the case where the instrument is addressed as the talker; “OUTPUT” indicates that the controller is the talker.

**4-125. Example 1.** Zero the instrument and take a reading with channel 1 from a signal generator.

Setup conditions : Select channel 1 sensor data adapter  
Frequency of 5 Gigahertz  
Reading in milliwatts and also dBm  
Filter of 3 seconds  
Generator output is -17 dBm

OUTPUT "CH1": Select channel 1

OUTPUT "SS5" : use sensor data adapter

OUTPUT "FR5" : set frequency to 5 GHz

OUTPUT "FL3" : set filter to 3 seconds

OUTPUT "TM0" : set TALK MODE to "0"

disconnect sensor from generator

WAIT 1000 : wait one second

OUTPUT "ZR" : zero instrument

WAIT 30000 : wait for zero to complete

Reconnect sensor to generator

WAIT 3000 : the filter time constant

INPUT A,B : get reading from 4230A

PRINT A : print "0" which is the error code

PRINT B : print ".01995" which is the power in milliwatts

Change talk mode and take another reading in dBm

OUTPUT "TM1" : set TALK MODE to "1"

OUTPUT "DB" : set 4230A to dBm display

WAIT 3000 : the filter time constant

INPUT A\$ : get a reading from the 4230A

PRINT A\$ : print string variable "0,-17.00dBm"

**4-126. Example 2.** Take triggered readings with Channel 1 and 2 from signal generators.

Setup conditions : Select sensor data adapters  
Channel 1 power = 100 microwatts  
Channel 2 power = 350 microwatts  
Channel 1 frequency = 18 GHz  
Channel 2 frequency = 5 GHz  
Reading in milliwatts  
Autofilter

Setup channel 1

OUTPUT "CH1" : select channel 1

OUTPUT "SS5" : use sensor data adapter

OUTPUT "FR18" : set frequency to 18 GHz

OUTPUT "PW" : set WATTS display

OUTPUT "FA" : set filter to Autofilter

Setup channel 2

OUTPUT "CH2" : select channel 2

OUTPUT "SS6" : use sensor data adapter

OUTPUT "FR5" : set frequency to 5 GHz

OUTPUT "PW" : set Watts display

OUTPUT "FA" : set filter to Autofilter

Setup trigger mode

OUTPUT "TM3" : set TALK MODE to 3

OUTPUT "TS" : set Trigger Settled operation

Connect sensor to generator

TRIGGER : send Group Execute Trigger

INPUT A,B,C,D : get reading from Model 4230A

PRINT A,B : print channel 1 "0,100.00E-3"

PRINT C,D : print channel 2 "0,350.00E-3"

**4-127. ERROR MESSAGES.**

**4-128.** The error messages returned over the bus are described in Table 4-6. They are in numerical order as would be sent out over the IEEE-488 bus.

**4-129. HP 437B and 438A BUSEMULATION.**

**4-130.** The Model 4230A native mode is a superset of the mnemonics used for the Boonton Model 4220A RF Power Meter. Additional commands have been added to support dual channel operation, sensor data adapters and the high speed sampling modes. The Model 4230A is equipped to emulate the HP 437B and 438A bus mnemonics. These modes are available for users wanting to use the Model 4230A in existing systems who cannot re-write their application programs. Refer to paragraph 3-20 for configuring the Model 4230A for these modes of operation. The IEEE-488 capabilities in the HP emulation mode are the same as the native mode as described in paragraphs 4- 55 through 4- 65.

**4-131. Turn-on Default Conditions.** Several emulation parameters are reset at turn-on. The parameters and their default conditions are listed below.

Bus emulation mode = 4230A (factory default)

GPIB Local Mode

Unaddressed

Service Request Mask cleared  
 Status Byte cleared  
 Free Run Trigger Mode  
 GT2 (Trigger with Delay) response to Trigger message  
 Event Status Enable Mask = 0

**4-132. Sending the Data Message.**

**4-133. Data Output Format.** The output data is usually formatted as a real constant in exponential form. That is; first the sign, then a 5 digit number with the decimal point appropriately located followed by the letter E (signifying that an exponent follows). The letter E is followed by a signed power-of-ten multiplier. The string is terminated by the EOS character set via the Menu-Setup-IEEE-EOS talker/listener commands (refer to paragraph 3-20).

Exceptions to this format are the data output for the following functions:

- Identification
- Read Service Request Mask Value
- Read Event Status Register Mask Value
- Read Event Status Register Value

**Identification.** This function is used to identify the Power Meter's model number and the firmware version. After receiving the \*IDN? or ID (437B) or the ?ID (438A) mnemonic and when addressed to talk, the Power Meter sends the following string:

BOONTONELECTRONICS,4230A,,X.XX

4230A is the instrument model number and X.XX is the firmware version number.

**4-134. Sending the Require Service Message.** The Power Meter sends the Require Service message by setting the Service Request (SRQ) bus control line true. The front panel SRQ annunciator is enabled when the Status Byte has been set. The Require Service message is cleared when a serial poll is executed by the controller or when a "CS" (clear status byte) or "\*CLS" (clear all status bytes) mnemonic is received via a Data message.

There are five conditions that can be enabled to cause the Require Service message to be sent. These conditions, which are enabled by the Service Request Mask, are as follows:

**Data Ready:** When the Power Meter has a data point requested by a trigger command.

**Cal/Zero Completed:** When the Power Meter has completed a calibration or zeroing cycle.

**Entry Error:** When a number is entered via GPIB that is out of the allowable range for the selected parameter.

**Measurement Error:** When the power applied to the sensor is incorrect for the current instrument configuration.

**Event Status Register:** When a specified condition in the Event Status Register occurs and the corresponding bit in the Event Status Enable Register is enabled (via \*ESE), this bit will be set true.

**4-135. Service Request Mask.** This mask determines which bits can set the Status Byte's SRQ bit true (see Table 4-8). When this bit becomes true, the SRQ line is also true. To set the mask, use the \*SRE or "@1" mnemonic followed by an argument between the values of 0 and 255. The argument is determined by summing the weights of each bit to be checked.

**4-136. Sending the Service Request Mask Value.** The program mnemonics "\*SRE?" and "RV" will cause the Power Meter to respond when addressed to talk, with the present value of the Service Request Mask. This value is the summed weights of the bits that are set true. The bit pattern can be interpreted with the information in Table 4-8.

**TABLE 4-8. STATUS BYTE AND SERVICE REQUEST MASK (HP437B and 438A ONLY)**

| Bit | Value     |               | Description           |
|-----|-----------|---------------|-----------------------|
|     | (decimal) | (hexadecimal) |                       |
| 0   | 1         | 1             | Data Ready            |
| 1   | 2         | 2             | Cal/Zero Complete     |
| 2   | 4         | 4             | Entry Error           |
| 3   | 8         | 8             | Measurement Error     |
| 4   | 16        | 10            | Not supported         |
| 5   | 32        | 20            | Event Status Register |
| 6   | 64        | 40            | Require Service (RQS) |
| 7   | 128       | 80            | Not used; always zero |

**4-137. Event Status Register.** This register is a second status byte which extends the use of the Service Request Status Byte (see Table 4-9). The bits are set true when the specified event occurs provided the enable mask has been previously set. The mask is set by sending the "\*ESE" mnemonic followed by an argument, the summed value of the bits of the desired condition to request service.

When a bit in the Event Status Register is set true, bit 5 of the Status Byte will also be sent if so enabled. The value of this register can be read via the "\*ESR?" program code. After the instrument receives this command, the next time it is addressed to talk a number will be sent representing the weighted value of the bits set.

**TABLE 4-9. EVENT STATUS REGISTER  
(HP437B and HP438A ONLY)**

| <u>Bit</u> | <u>Value</u> | <u>Description</u>     |
|------------|--------------|------------------------|
| 0          | 1            | Not used; always zero  |
| 1          | 2            | Not used; always zero  |
| 2          | 4            | Not used; always zero  |
| 3          | 8            | Device Dependent Error |
| 4          | 16           | Execution Error        |
| 5          | 32           | Command Error          |
| 6          | 64           | Not used; always zero  |
| 7          | 128          | Power On               |

**Device Dependent Error:** This bit is set when a measurement error occurs.

**Execution Error:** This bit is set when improper data has been received by the instrument. For example, sending a negative value for frequency is considered an execution error.

**Command Error:** This bit is set when the instrument parses a GPIB mnemonic which is not recognized. For example, the program code "XX" would produce a command error.

**Power On.** This bit is set in the instrument's initialization sequences when the power is toggled from OFF (0) to ON (1).

**4-138. HP Emulation Codes.** The Model 4230A has the ability to emulate many of the HP 437B and HP 438A remote programming modes. Tables 4-10 and 4-11 summarizes the HP mnemonic set. In cases where the Model 4230A cannot execute the HP code, it is noted with the comment "NOT SUPPORTED". The Emulation Mode can be enabled either by the Menu-SETUP-IEEE-EMULATION command (437B or 438A option) or by sending the "HPS" or "HPD" program code via the bus. This mode is disabled by setting the Menu-SETUP-IEEE-EMULATION command to the "4230A" option or sending the "BN" mnemonic over the bus. The Boonton 4230A command set is listed in Table 4-12.

**4-139. REMOTE OPERATION, RS-232 INTERFACE.**

**4-140. General.** RS-232 interface is available for the Model 4230A in lieu of the IEEE-488. The command set and data transfer protocol are nearly identical to those for the GPIB option. The Menu-SETUP-RS-232 commands are used to configure the RS-232 interface to comply with the terminal in use. Setting the end-of-string character and SRQ Mask is accomplished by using the EOS Talker/Listener and SRQ Mask commands respectively.

**4-141. Entering the Remote Mode.** The Model 4230A enters the remote mode when the ASCII "SI" character (hexadecimal 0F/CTRL O) is received. In the remote state, the front panel keyboard is disabled, except for the <Menu>

key which serves as the return to local function. The display will show the REM indicator on the last line and enable the TLK, LSN and SRQ as appropriate.

**4-142. Returning to Local Mode.** The instrument will return to the local state when;

- a. The <Menu> key is pressed.
- b. The ASCII "SO" character (hexadecimal 0E/CTRL N) is received.

**NOTE**

The instrument must be placed in the remote state for it to respond to data messages. It is not possible to store data in the local state for execution in the remote state.

**4-143. Talk Operations.** The Model 4230A can be requested to talk in two ways. The "??" mnemonic is available for requesting data via the RS-232 port. Immediately after receiving this mnemonic, the instrument responds by transmitting data based on the current talk mode. For example, the following interactive sequence causes the Model 4230A to transmit the measurement with the associated units:

| <u>Terminal Sends</u>     | <u>Model 4230A Response</u>   |
|---------------------------|---|
| O (CTRL O/hexadecimal 0F) | REM annunciator illuminates, indicating remote operation.   |
| DB TM1 ??<ENTER>          | Set measurement to dBm, set the talk mode to 1 (talk measurement with units), talk.<br><br>0,-3.00 dBm - No error at -3 dBm |

**NOTE**

<ENTER> means transmit end-of-string as defined via the Menu-SETUP-RS 232-EOS Listener parameter (typically CR).

**4-144.** Additionally, the ASCII "DC2" character (hexadecimal 12/CTRL R) will cause the instrument to immediately transmit data based on the current talk mode. Continuing the above example:

| <u>Terminal Sends</u>     | <u>Model 4230A Response</u>  |
|---------------------------|--|
| TM0 <ENTER>               | Set the talk mode to send Floating Point Measurements.   |
| R (CTRL R/hexadecimal 12) | Talk the error flag and the measurement in floating point notation.<br><br>0,-3.00 - no error, power is -3 dBm |

**4-145.** The rules for number and data strings are the same as for the IEEE-488 interface. Number formats are free form and data strings are case insensitive.

**TABLE 4-10. HP 437B EMULATION GPIB COMMANDS**

| <b>437B Code</b> | <b>Description</b>                                      | <b>Comments</b> |
|------------------|---|-----------------|
| CL               | 0 dBm Calibration <sup>1</sup>                          |                 |
| *CLS             | Clear the status register <sup>3</sup>                  |                 |
| CS               | Clear the status byte                                   |                 |
| CT0 - CT9        | Clear sensor data tables 0 - 9 <sup>1</sup>             | NOT SUPPORTED   |
| DA               | All display segments on                                 |                 |
| DC0              | Duty cycle on ('DY' ARG # 100)                          | NOT SUPPORTED   |
| DC1              | Duty cycle off ('DY' ARG = 100)                         | NOT SUPPORTED   |
| DD, DF           | Display disable   |                 |
| DE               | Display enable  |                 |
| DN               | Down arrow key  |                 |
| DU               | Display user message                                    |                 |
| DY               | Duty cycle value <sup>1</sup>                           |                 |
| EN               | ENTER   |                 |
| ERR?             | Device error query                                      |                 |
| *ESE             | Set event status enable mask <sup>3</sup>               |                 |
| *ESE?            | Event status register query <sup>3</sup>                |                 |
| *ESR?            | Event status register (ESR) query <sup>3</sup>          |                 |
| ET0 - ET9        | Edit sensor calibration factor table 0 - 9 <sup>1</sup> | NOT SUPPORTED   |
| EX               | EXIT  |                 |
| FA               | Automatic filter selection                              |                 |
| FH               | Filter hold   |                 |
| FM               | Manual filter selection <sup>1</sup>                    |                 |
| FR               | Frequency entry <sup>1</sup>                            |                 |
| GT0              | Ignore group execute trigger (GET) bus command          |                 |
| GT1              | Trigger immediate response to GET command               |                 |
| GT2              | Trigger with delay response to GET command              |                 |
| GZ               | Gigahertz   |                 |
| HZ               | Hertz   |                 |
| ID               | GPIB identification query                               |                 |
| *IDN?            | GPIB identification query <sup>2</sup>                  |                 |
| KB               | calibration factor <sup>1</sup> in percent              |                 |

**TABLE 4-10. HP 437B EMULATION GPIB COMMANDS (CONT)**

| <b>437B Code</b> | <b>Description</b>                                     | <b>Comments</b> |
|------------------|--|-----------------|
| KZ               | Kilohertz  |                 |
| LG               | Log display  |                 |
| LH               | High limit <sup>1</sup>                                |                 |
| LL               | Low limit <sup>1</sup>                                 |                 |
| LM0              | Disable limits checking function                       |                 |
| LM1              | Enable limits checking function                        |                 |
| LN               | Linear display   |                 |
| LP               | Learn Mode   | NOT SUPPORTED   |
| LT               | Left arrow key   |                 |
| MZ               | Megahertz  |                 |
| OC0              | Reference oscillator off                               |                 |
| OC1              | Reference oscillator on                                |                 |
| OD               | Output display text                                    | NOT SUPPORTED   |
| OF0              | Offset off <sup>4</sup>                                | NOT SUPPORTED   |
| OF1              | Offset on <sup>4</sup>                                 | NOT SUPPORTED   |
| OS               | Offset value <sup>1</sup>                              |                 |
| PCT              | Percent  |                 |
| PR               | Preset   |                 |
| RA               | Autorange  |                 |
| RC               | RECALL <sup>1</sup>                                    | 1 - 4           |
| RE               | Resolution <sup>1</sup>                                | 1 - 3           |
| RF0 - RF9        | Enter sensor reference calibration factor <sup>1</sup> | NOT SUPPORTED   |
| RH               | Range hold   |                 |
| RL0              | Exit REL mode  |                 |
| RL1              | Enter REL mode using new REL value                     |                 |
| RL2              | Enter REL mode using old REF value                     |                 |
| RM               | Set range <sup>1</sup>                                 |                 |
| *RST             | Soft reset   |                 |
| RT               | Right arrow key  |                 |
| RV               | Read Service Request Mask value                        |                 |
| SE               | Sensor number <sup>1</sup>                             | 1-6 only        |



**TABLE 4-10. HP 437B EMULATION GPIB COMMANDS (CONT)**

| <b>437B Code</b> | <b>Description</b>                        | <b>Comments</b> |
|------------------|---|-----------------|
| SM               | Status message                            | NOT SUPPORTED   |
| SN0 - SN9        | Enter sensor serial number <sup>2</sup>   | NOT SUPPORTED   |
| SP - NOP         | SPECIAL                                   | NOT SUPPORTED   |
| *SRE             | Set the service request mask <sup>3</sup> |                 |
| *SRE?            | Service request mask query <sup>3</sup>   |                 |
| ST               | STORE <sup>1</sup>                        | 1 - 4           |
| *STB?            | Read the status byte                      |                 |
| TR0              | Trigger hold                              |                 |
| TR1              | Trigger immediate                         |                 |
| TR2              | Trigger with delay                        |                 |
| TR3              | Trigger-free run                          |                 |
| *TST?            | Self test query <sup>3</sup>              |                 |
| UP               | Up arrow key                              |                 |
| ZE               | ZERO                                      |                 |
| @1               | Set the service request mask              |                 |
| @2               | Learn mode prefix                         | NOT SUPPORTED   |
| %                | Percent                                   |                 |

- 1 A numeric entry is required by these GPIB codes, followed by the code EN (ENTER).
- 2 This GPIB code uses the next 6 characters (0 - 9, A - Z, or an underscore) as input data.
- 3 The \* must be included as part of the GPIB command string.
- 4 Offset value is always applied. Set the offset value to 0 dB for off condition. Any other value the offset is on.

**TABLE 4-11. HP 438A EMULATION GPIB COMMANDS**

| <b>438A Code</b> | <b>Description</b>  | <b>Comments</b>           |
|------------------|---|---------------------------|
| AD               | Measure A-B   |                           |
| AE               | Set A   |                           |
| AP               | Measure sensor A  |                           |
| AR               | Measure A/B   |                           |
| BD               | Measure B-A   |                           |
| BE               | Set B   |                           |
| BP               | Measure sensor B  |                           |
| BR               | Measure B/A   |                           |
| CL               | CAL ADJ <sup>1,2</sup>  |                           |
| CS               | Clear status byte <sup>1</sup>                                    |                           |
| DA               | Display all <sup>1</sup>  |                           |
| DD               | Display disable <sup>1</sup>                                      |                           |
| DE               | Display enable <sup>1</sup>                                       |                           |
| DO               | Measured offset entry   |                           |
| EN               | ENTER <sup>1</sup>  |                           |
| FA               | Set auto average filtering  | (precede with AE or BE)   |
| FH               | Hold present average number                                       | (precede with AE or BE)   |
| FM               | Set filter number <sup>1,2</sup>                                  | (precede with AE or BE)   |
| GT0              | Group execute trigger cancel <sup>1</sup>                         |                           |
| GT1              | Group execute trigger single measurement <sup>1</sup>             |                           |
| GT2              | Group execute trigger full measurement with settling <sup>1</sup> |                           |
| GZ               | Gigahertz <sup>1</sup>  |                           |
| HZ               | Hertz <sup>1</sup>  |                           |
| ?ID              | Ask of ID <sup>1</sup>  |                           |
| KB               | Calibration factor <sup>1,2</sup>                                 |                           |
| KZ               | Kilohertz <sup>1</sup>  |                           |
| LG               | Set log units   | (dB or dBm) <sup>1</sup>  |
| LH               | High limit <sup>1,2</sup>   |                           |
| LL               | Low limit <sup>1,2</sup>  |                           |
| LM0              | Disable limit checking <sup>1</sup>                               |                           |
| LM1              | Enable limit checking <sup>1</sup>                                |                           |
| LN               | Set linear units  | (Watts or %) <sup>1</sup> |
| LP1              | Set learn mode #1   | NOT SUPPORTED             |
| LP2              | Set learn mode #2   | NOT SUPPORTED             |

**TABLE 4-11. HP 438A EMULATION GPIB COMMANDS (CONT)**

| 438A Code | Description   | Comments                             |
|-----------|---|--------------------------------------|
| MZ        | Megahertz <sup>1</sup>                              |                                      |
| OC0       | Turn off calibrator source <sup>1</sup>             |                                      |
| OC1       | Turn on calibrator source <sup>1</sup>              |                                      |
| OS        | Offset <sup>1,2</sup>                               |                                      |
| PR        | Preset instrument to a known state <sup>1</sup>     |                                      |
| RA        | Resume autorange <sup>1</sup>                       |                                      |
| RC        | RECALL <sup>1,2</sup>                               | 1-4 only                             |
| RH        | Range hold <sup>1</sup>                             |                                      |
| RL0       | Relative mode off <sup>1</sup>                      |                                      |
| RL1       | Relative mode on <sup>1</sup>                       |                                      |
| RL2       | Relative mode with old REL value <sup>1</sup>       |                                      |
| RM        | Set manual range <sup>1,2</sup>                     |                                      |
| RV        | Ask for status request mask <sup>1</sup>            |                                      |
| SM        | Ask for status message <sup>1</sup>                 |                                      |
| ST        | STORE <sup>1,2</sup>                                | 1-4                                  |
| TR0       | Trigger hold mode <sup>1</sup>                      |                                      |
| TR1       | Trigger single measurement <sup>1</sup>             |                                      |
| TR2       | Trigger full measurement with settling <sup>1</sup> |                                      |
| TR3       | Free run trigger mode <sup>1</sup>                  |                                      |
| ZE        | Zero sensor   | (precede with AE or BE) <sup>1</sup> |
| @1        | Prefix for service request mask <sup>1</sup>        |                                      |

1 These commands are fully compatible with the HP437B Power Meter command codes.

2 Requires numeric entry followed by program code EN.

**TABLE 4-12. BOONTON 4230A GPIB COMMANDS**

| <b>Code</b> | <b>Description</b>                                  | <b>Comments</b>               |
|-------------|---|-------------------------------|
| AM          | Measure A-B   |                               |
| AP          | Measure A + B                                       |                               |
| AR          | Measure A/B   |                               |
| BD          | Measure B - A                                       |                               |
| BR          | Measure B/A   |                               |
| BN          | 4230A Native mode                                   | NOEMULATION                   |
| CH          | Channel select                                      | 1 - 2                         |
| CF          | Calibrator off                                      |                               |
| CL          | Clear   |                               |
| CN          | Calibrator on                                       |                               |
| CP          | Calibrate   |                               |
| DB          | dBm select  |                               |
| DF          | Display off   |                               |
| DN          | Display on  |                               |
| DR          | dBr select  |                               |
| DU          | Display user message                                |                               |
| DY          | Duty cycle value                                    | 0.01 - 100.00 in 0.01 steps   |
| FA          | Auto filter   |                               |
| FD          | dB calibration factor                               | -3.00 to 3.00 in 0.01 steps   |
| FI          | Send high frequency calibration data to instrument  |                               |
| FL          | Filter time select                                  | 0 to 20.00 in 0.05 steps      |
| FO          | Get high frequency calibration data from instrument |                               |
| FR          | Frequency select                                    |                               |
| HPS         | Enable HP 437B emulation mode                       |                               |
| HPD         | Enable HP 438A emulation mode                       |                               |
| ?ID         | Talk instrument ID                                  |                               |
| *IDN?       | Talk instrument ID                                  |                               |
| LH          | High limit  | -99.99 to 99.99 in 0.01 steps |
| LL          | Low limit   | -99.99 to 99.99 in 0.01 steps |
| LM0         | Disable limits checking function                    |                               |
| LM1         | Enable limits checking function                     |                               |
| LR          | Load reference                                      |                               |

**TABLE4-12. BOONTON 4230A GPIB COMMANDS (CONT)**

| <b>Code</b> | <b>Description</b>                 | <b>Comments</b>               |
|-------------|------------------------------------|-------------------------------|
| MF          | Measure filtered                   |                               |
| MFD         | Measure Fast Dual Channels         |                               |
| MFS         | Measure fast single channel        |                               |
| MN          | Measure normal, free run           |                               |
| MS          | Measure settled                    |                               |
| OS          | Offset value                       | -99.99 to 99.99 in 0.01 steps |
| PW          | Watts select                       |                               |
| RA          | Autorange                          |                               |
| RB          | Recorder bottom                    |                               |
| RC          | Recall instrument configuration    | 1 - 4                         |
| RE          | Resolution                         | 1 - 3                         |
| RN          | Recorder normal                    |                               |
| RS          | Range select                       | 0 - 6                         |
| RT          | Recorder top                       |                               |
| SI          | Send linearity data to instrument  |                               |
| SM          | Service request (SRQ) mask         | 0 - 255                       |
| SO          | Get linearity data from instrument |                               |
| SR          | Set dBr reference                  | -99.99 to 99.99 in 0.01 steps |
| SS          | Sensor select                      | 1 - 6                         |
| ST          | Store instrument configuration     | 1 - 4                         |
| TF          | Trigger filtered                   |                               |
| TFD         | Trigger fast dual channels         |                               |
| TFS         | Trigger fast single channel        |                               |
| TN          | Trigger normal                     |                               |
| TM          | Talk mode                          | 0 - 6                         |
| TR          | Bus trigger                        |                               |
| TS          | Trigger settled                    |                               |
| ZR          | Instrument zero                    |                               |

- 1 A numeric entry is required by these GPIB codes, followed by the code EN (ENTER).
- 2 This GPIB code uses the next 6 characters (0 - 9, A - Z, or an underscore) as input data.
- 3 The \* must be included as part of the GPIB command string.

# RF VOLTMETER SECTION

REF. MANUAL P/N 98202000A  
DATE 10/98

# MODEL 9230 SERIES RF VOLTMETER INSTRUCTION MANUAL

## **BOONTON**

BOONTON ELECTRONICS ■ 25 EASTMANS ROAD ■ PARSIPPANY, NEW JERSEY 07054-0465

TELEPHONE: (973) 386-9696 ■ FAX: (973) 386-9191 ■ E-MAIL: [boonton@boonton.com](mailto:boonton@boonton.com)

---

MANUAL P/N 98202000A  
DATE 10/98

# IMPORTANT NOTICE

JANUARY 22, 1999

INSTRUCTION MANUAL-ADDENDUM: MODEL 5230, RF VOLTMETER SECTION & 9230

Instruction manual addenda are issued to adapt the manual to changes and improvements made after this printing. Please review the following text and retain with your manual for future reference. These changes will be applied in the next printing of the manual.

**Thank you for selecting BOONTON ELECTRONICS for your Test and Measurement needs.**

## GENERAL INFORMATION

Page 1-1, Paragraph 1-2. Description. (sub-paragraph 1)

Replace "300 volts" with "10 volts RMS".

Page 1-1, Paragraph 1-3. Design Features. (sub-paragraph 3)

Replace "the voltage range can be extended to 300 V"  
with "the RF voltage range can be extended to 50 volts RMS"

Page 1-4, Table 1, Performance Specifications, Voltage Range

Replace "(20 mV to 300V with 100:1 Divider)" with

"(20 mV to 50 V with 100:1 Divider when applicable)"

Page 1-5, Table 1-1, Performance Specifications, Maximum AC Input

Replace "10 V, all frequencies and ranges" with

"Sensor dependent:

Model 952001B 10 V RMS 100 kHz to 1.2 GHz

Model 952016 10 V RMS 10 Hz to 100 MHz

Model 952009 2 V RMS 100 kHz to 2.5 GHz

Other - Refer to sensor specification."

98202001A, Model 9230 & 98202101A Model 5230 Voltmeter Section



Page 1-5, Table 1-1, Performance Specifications, Maximum DC Input

Replace "200 V, all ranges" with  
"Sensor dependent:  
Model 952001B 60 V  
Model 952016 60 V  
Model 952009 50 V  
Other - Refer to sensor specification."

Page 1-10, Table 1-1, Performance Specifications(cont'd), CE MARK  
Add: Installation Category II

#### SECTION IV APPLICATION NOTES

Page 4-1, Paragraph 4-3. Overload Limits.

Replace sub-paragraph 1. with the following:

1. The maximum voltage which can be applied to a voltage probe Model 952001B or Model 952016 is limited to 60 VDC and 10 VAC (RMS). If the applicable 100:1 Divider is attached to the probe, the maximum AC voltage is increased to 50 VAC (RMS).

**WARNING**

A safety hazard exists if voltage probes are connected to voltages which exceed the maximum ratings.

Page 4-1, Paragraph 4-3. Overload Limits, sub-paragraph 2.

Replace "10 volts" with "3 volts"

Page 4-1, Paragraph 4-3. Overload Limits, sub-paragraph 3.

Replace sub-paragraph 3 with the following:

3. When using the Model 952003 Tee Adapter and other 50 ohm accessories, do not exceed the power ratings of the 50 ohm terminations and attenuators.

98202001A. Model 9230 & 98202101A Model 5230 Voltmeter Section

# IMPORTANT NOTICE

September 17, 1999

OPERATION AND MAINTENANCE MANUAL-ADDENDUM: MODEL 9230

Operation and Instruction manual addenda are issued to adapt the manual to changes and improvements made after this printing. Please review the following text and retain with your manual for future reference. These changes will be applied in the next printing of the manual.

**Thank you for selecting BOONTON ELECTRONICS for your Test and Measurement needs.**

Page 4-13 ,Table 4-8, GPIB COMMANDS

DELETE: "PW-Watts select"

ADD:

| CODE | DESCRIPTION          |
|------|----------------------|
| DMV  | dBmV units selection |
| DV   | dBV units selection  |
| DW   | dBW units selection  |

# IMPORTANT NOTICE

June 10, 2004

INSTRUCTION MANUAL-ADDENDUM: MODEL 9230

Operation and Instruction manual addenda are issued to adapt the manual to changes and improvements made after this printing. Please review the following text and retain with your manual for future reference. These changes will be applied in the next printing of the manual.

**Thank you for selecting BOONTON ELECTRONICS for your Test and Measurement needs.**

Page 4-8, paragraph 4-41, line 6 – change text “paragraph 4-85” to “paragraph 4-42”.

Page 4-8, paragraph 4-43, line 3 – change text “paragraph 4-75” to “paragraph 4-32”.

98202003A

# TABLE OF CONTENTS

## SECTION I — GENERAL INFORMATION

| Paragraph |   | Page |
|-----------|---|------|
| 1-1       | Introduction .....                          | 1-1  |
| 1-2       | Description .....                           | 1-1  |
| 1-3       | Design Features .....                       | 1-1  |
| 1-4       | Simple Instrument Setup and Operation ..... | 1-1  |
| 1-5       | Display .....                               | 1-2  |
| 1-6       | Selectable Ranging .....                    | 1-2  |
| 1-7       | Selectable Filtering .....                  | 1-2  |
| 1-8       | Zeroing .....                               | 1-2  |
| 1-9       | Chart Recorder Output .....                 | 1-2  |
| 1-10      | Optional Interfaces .....                   | 1-2  |
| 1-11      | High/Low Limit Alarms .....                 | 1-2  |
| 1-12      | Accessories .....                           | 1-2  |
| 1-14      | Options .....                               | 1-3  |
|           | Option -01 .....                            | 1-2  |
|           | Option -03 .....                            | 1-2  |
|           | Option -30 .....                            | 1-2  |

## SECTION II — INSTALLATION

|      |                          |     |
|------|--------------------------|-----|
| 2-1  | Introduction .....       | 2-1 |
| 2-2  | Unpacking .....          | 2-1 |
| 2-3  | Mounting .....           | 2-1 |
| 2-4  | Power Requirements ..... | 2-1 |
| 2-5  | Connections .....        | 2-1 |
| 2-6  | Sensor .....             | 2-1 |
| 2-7  | Recorder .....           | 2-1 |
| 2-8  | GPIB .....               | 2-1 |
| 2-9  | RS-232 .....             | 2-1 |
| 2-10 | Preliminary Check .....  | 2-2 |

## SECTION III — OPERATION

|      |   |      |
|------|---|------|
| 3-1  | Introduction .....                                  | 3-1  |
| 3-3  | Operating Controls, Indicators and Connectors ..... | 3-1  |
| 3-5  | Operating the Instrument .....                      | 3-1  |
| 3-7  | Measurement Display .....                           | 3-1  |
| 3-9  | Menu Structure .....                                | 3-1  |
| 3-13 | Menu Key .....                                      | 3-7  |
| 3-16 | Channel Menu .....                                  | 3-7  |
| 3-18 | Setup Menu .....                                    | 3-7  |
| 3-20 | IEEE Menu .....                                     | 3-11 |
| 3-21 | RS-232 Menu .....                                   | 3-11 |
| 3-22 | Diagnostics Menu .....                              | 3-13 |
| 3-23 | Sensor Key .....                                    | 3-13 |
| 3-31 | Edit Data Menu .....                                | 3-14 |
| 3-32 | Linearity Factors .....                             | 3-14 |
| 3-34 | Saving the Edited Values .....                      | 3-15 |
| 3-35 | Freq Key .....                                      | 3-15 |
| 3-36 | Avg Key .....                                       | 3-15 |
| 3-39 | ZeroKey .....                                       | 3-16 |
| 3-40 | Ref Level Key .....                                 | 3-16 |

## SECTION IV — APPLICATION NOTES

|      |  |      |
|------|--|------|
| 4-1  | Zeroing .....  | 4-1  |
| 4-2  | Making Measurements .....                                  | 4-1  |
| 4-3  | Overload Limits .....                                      | 4-1  |
| 4-5  | Connection Recommendations .....                           | 4-1  |
| 4-6  | Low Level Measurements .....                               | 4-1  |
| 4-7  | Temperature Effects .....                                  | 4-1  |
| 4-8  | Hum, Noise and Spurious Pickup .....                       | 4-3  |
| 4-9  | Recorder Output .....                                      | 4-3  |
| 4-10 | Correction Curve for Model 952003 .....                    | 4-3  |
| 4-11 | Correction Curve for Model 952007 .....                    | 4-3  |
| 4-12 | RF Power Measurements .....                                | 4-3  |
| 4-13 | Remote (GPIB) Operation .....                              | 4-3  |
| 4-14 | Introduction .....   | 4-3  |
| 4-16 | Local Operation .....                                      | 4-4  |
| 4-17 | Remote Operation .....                                     | 4-4  |
| 4-18 | Bus Address .....  | 4-4  |
| 4-19 | Terminating Characters .....                               | 4-4  |
| 4-20 | Listen Operation .....                                     | 4-4  |
| 4-21 | Talk Operation .....                                       | 4-4  |
| 4-23 | IEEE-488 Command Support .....                             | 4-4  |
| 4-24 | Number Formatting .....                                    | 4-4  |
| 4-25 | String Format .....  | 4-5  |
| 4-26 | Listen Parameter Commands .....                            | 4-6  |
| 4-28 | Listen Action Commands .....                               | 4-6  |
| 4-29 | Listen Array Commands .....                                | 4-5  |
| 4-30 | Talk Modes .....   | 4-6  |
| 4-34 | Talk Mode 0 (Talk Measurement Floating Point) .....        | 4-6  |
| 4-35 | Talk Mode 1 (Talk Measurement With Units) .....            | 4-6  |
| 4-36 | Talk Mode 2 (Talk Error) .....                             | 4-6  |
| 4-37 | Talk Mode 3 (Talk Both Channels) .....                     | 4-6  |
| 4-38 | Talk Mode 4 (Talk Channel Status) .....                    | 4-8  |
| 4-39 | Talk Mode 5 (Talk Instrument Status) .....                 | 4-8  |
| 4-40 | Talk Mode 6 (Talk Parameter) .....                         | 4-8  |
| 4-43 | Talk Mode 7 (Talk Array) .....                             | 4-8  |
| 4-44 | Talk Mode (TM) Command .....                               | 4-8  |
| 4-45 | VSO Command .....  | 4-8  |
| 4-46 | VSI Command .....  | 4-9  |
| 4-47 | DF Command .....   | 4-9  |
| 4-48 | DN Command .....   | 4-9  |
| 4-49 | SM (SRQ Mask) .....  | 4-9  |
| 4-50 | Measured and Triggered Operation And Settled Reading ..... | 4-9  |
| 4-51 | General .....  | 4-9  |
| 4-52 | Measure Normal (MN) .....                                  | 4-9  |
| 4-53 | Measure Filtered (MF) .....                                | 4-10 |
| 4-54 | Measure Settled (MS) .....                                 | 4-10 |
| 4-55 | Measure Fast Single (MFS) .....                            | 4-10 |
| 4-56 | Measure Fast Dual (MFD) .....                              | 4-10 |
| 4-57 | Trigger Normal (TN) .....                                  | 4-10 |
| 4-58 | Trigger Filtered (TF) .....                                | 4-10 |
| 4-59 | Trigger Settled (TS) .....                                 | 4-10 |
| 4-60 | Trigger Fast Single (TFS) .....                            | 4-10 |
| 4-61 | Trigger Fast Dual (TFD) .....                              | 4-10 |

|      |  |      |
|------|--|------|
| 4-62 | IEEE Programming Examples .....          | 4-10 |
| 4-63 | Remote Operation, RS-232 Interface ..... | 4-10 |
| 4-64 | General .....                            | 4-10 |
| 4-65 | Entering the Remote Mode .....           | 4-10 |
| 4-66 | Returning to Local Mode .....            | 4-11 |
| 4-67 | Talk Operations .....                    | 4-11 |

# LIST OF FIGURES

| <b>Figures</b> |   | <b>Page</b> |
|----------------|---|-------------|
| 1-1            | Model 9230 Series RF Voltmeter .....  | vi          |
| 1-2            | Input Impedance .....   | 1-6         |
| 1-3            | Outline Dimensions .....  | 1-11        |
| 2-1            | Packaging Diagram .....   | 2-3         |
| 3-1            | Model 9230, Front Panel Controls and Connectors .....                         | 3-3         |
| 3-2            | Model 9230, Rear Panel Controls and Connectors .....                          | 3-3         |
| 3-3            | Measurement Display, Local Mode .....   | 3-5         |
| 3-4            | Measurement Display, Remote Mode .....  | 3-5         |
| 3-5            | Model 9230, Command Set .....   | 3-6         |
| 3-6            | Main Menu Display .....   | 3-7         |
| 3-7            | Channels Menu Display .....   | 3-7         |
| 3-8            | Setup Menu Display, IEEE Installed .....                                      | 3-9         |
| 3-9            | Setup Menu Display, RS-232 Installed .....                                    | 3-9         |
| 3-10           | IEEE Menu Display .....   | 3-11        |
| 3-11           | RS-232 Menu Display .....   | 3-12        |
| 3-12           | Diagnostics Menu Display .....  | 3-13        |
| 3-13           | Sensor Display Menu .....   | 3-13        |
| 3-14           | Edit Data Menu Display .....  | 3-14        |
| 3-15           | Averaging Time Display .....  | 3-16        |
| 3-16           | Zero and Calibration Display .....  | 3-16        |
| 3-17           | Reference Level Display .....   | 3-17        |
| 4-1            | Attachment of Model 952003 to Type N Tee Adapter to Model 952001B Probe ..... | 4-2         |
| 4-2            | Correction Curves for Model 952003 and 952007 .....                           | 4-2         |

# LIST OF TABLES

| <b>Table</b> |  | <b>Page</b> |
|--------------|--|-------------|
| 1-1          | Performance Specifications .....                     | 1-4         |
| 3-1          | Operating Controls, Indicators, and Connectors ..... | 3-1         |
| 3-2          | Channel Menu Functions .....                         | 3-8         |
| 3-3          | Setup Menu Functions .....                           | 3-10        |
| 3-4          | IEEE Menu Functions .....                            | 3-11        |
| 3-5          | RS-232 Menu Functions .....                          | 3-12        |
| 3-6          | Diagnostics Menu Functions .....                     | 3-13        |
| 3-7          | Edit Data Access Code .....                          | 3-14        |
| 3-8          | Edit Data Menu Functions .....                       | 3-15        |
| 3-9          | Reference Level Menu Functions .....                 | 3-17        |
| 4-1          | Listen Parameter Commands .....                      | 4-5         |
| 4-2          | Listen Action Commands .....                         | 4-7         |
| 4-5          | Talk Modes .....                                     | 4-9         |
| 4-6          | Error Messages .....                                 | 4-12        |
| 4-7          | SRQ Masks .....                                      | 4-12        |
| 4-8          | Boonton 9230A GPIB Commands .....                    | 4-13        |





# SECTION I

## GENERAL INFORMATION

### 1-1. INTRODUCTION.

This instruction manual provides general information, installation and operating instructions for the Model 9230 Series of RF Voltmeters. The 9230 Series includes single channel Model 9231 and dual channel Model 9232. The terms 9230 and Model 9230 used throughout this manual refer to both configurations unless otherwise noted.

### 1-2. DESCRIPTION.

The Model 9230 is a DSP (digital signal processor) based RF Voltmeter capable of measuring RF voltage levels from 200 microvolts to 300 volts (probe dependent) over a frequency range from 10 Hz to 2.5 GHz (probe dependent).

The voltage levels can be displayed in V, mV, dBV or dBmV. When the measured voltage is across a known impedance (5 ohms and 2500 ohms), the calculated power can be displayed in dBm or dBW.

### 1-3. DESIGN FEATURES.

**Wide Frequency Range.** The calibrated frequency range of the instrument is determined by the probe model used. The 952001B standard RF Probe provides calibrated measurements from 10 kHz to 1.2 GHz with usable indications beyond 4 GHz. The optional 952016 low frequency RF Probe provides calibrated response from 10 Hz to 100 MHz. The optional 952009 RF (50 ohm terminated) sensor provides calibrated a range from 100 kHz to 2.5 GHz.

Shaping and calibration data for each probe is contained in EEPROM within its 951090 Sensor Data Adapter. When the probe with its Data Adapter is plugged into the 9230 RF Voltmeter, the shaping and calibration data is downloaded and applied to the measurement automatically. It is not necessary to enter any data manually. Existing voltage probes can be used with the 9230 by loading a blank Data Adapter with calibration data. No further calibration of the probe is needed.

**Voltage Range.** The 9230 uses three internal hardware ranges to achieve a dynamic range of 90 dB. The input levels can range from less than 200 microvolts to 10 volts. Display resolution is selectable to 0.001 dB. Using the appropriate 100:1 Voltage Divider accessory, the voltage range can be extended to 300 Volts. For the 952001 RF Probe, use adapter Model 952005 to extend the voltage range to 300 V over a frequency range of 10 kHz to 20 MHz. The 100:1 divider cannot be used with the 952009 (50 ohm) RF Sensor.

For the purpose of compatibility with previous models and preexisting calibration procedures, the input range is divided into 9 virtual ranges which correspond to previous practice.

**True RMS Response.** The waveform response of the RF voltage probe is true RMS for voltages below 30 mV. This characteristic provides accurate measurements for all types of waveforms with levels up to 30 mV or 3 V with the appropriate 100:1 Voltage Divider. The waveform response of the probe gradually changes to a peak detecting response above 30 mV. Computer generated shaping allows the instrument to display RMS readings above 30 mV. This is valid for nearly sinusoidal waveforms.

For modulated signals, accurate results can be obtained at high levels if the modulation envelope is relatively flat, (e.g. FM, QPSK). For other modulation types (e.g. Am, Pulse, CDMA), accurate results can be obtained below 30 mV. The equivalent peak sinewave voltage can be displayed. It is 1.414 times the RMS voltage and 3.01 dB greater than the reading in decibel units.

**Low Noise.** The 9230 has been designed and constructed to minimize noise from all sources. A line filter and RF tight enclosure reject outside interference. The probe cables are a special low noise design; vigorous flexing causes only minor disturbances, even on low level measurements. Non-microphonic probes are used to lessen probe sensitivity to shock and vibration.

**1-4. Simple Instrument Setup and Operation.** The front panel membrane keypad provides access to menus which control instrument operation. The MENU key selects channel, setup and diagnostic menus.

The <SENSOR> key selects sensor related function.

The <AVG> key selects filter time averaging controls. Setting the filter time to zero will select the auto-filter mode. This selects an appropriate filter time without operator intervention.

The <REF LEVEL> key is used for making relative measurements in dB or percent. The values for these parameters are displayed and can be adjusted by using the arrow and enter keys.

Section I  
General Information

The <ZERO> key is used to zero the selected measurement channel. The <FREQ> key is not currently used.

**1-5. Display.** The backlit, 4 line, alphanumeric LCD display simultaneously displays both channels on Model 9232. A bar graph analog indication of level is also selectable.

**1-6. Selectable Ranging.** The normal mode of operation is Auto-Ranging. For special situations, any of the 8 measurement ranges can be held until the range setting is changed or the instrument is turned off. When measuring signals that fall within a narrow level range, holding at a specific range may reduce measurement time by eliminating range changes when test signals are switched. These 8 ranges are virtual ranges and only three hardware ranges are used.

**1-7. Selectable Filtering.** Measurement speed and display stability can be optimized by the use of the adjustable averaging filters. The averaging time, selected with the <AVG> key, can be increased to 20 seconds maximum in 50 millisecond increments. The number of stages in the filter is shown below the time setting, but cannot be set directly. Set the filter time to zero to activate the normal Auto-filtering mode.

**1-8. Zeroing.** The <ZERO> key independently controls the automatic zeroing of each probe and measurement channel. The RF probe must be disconnected from all signal sources during zeroing.

**1-9. Chart Recorder Output.** A 0 - 10 volt dc output proportional to the measurement is available for chart recorder or similar applications. The Chart Recorder Output is a BNC connector located on the rear panel.

**1-10. Interface Options.** The standard 9230 configuration includes an IEEE-488 (GPIB) bus interface for full programmable control of all instrument functions. The 9230 may be configured with an RS-232 interface which uses the same string commands as the GPIB. It is not possible to have both interfaces installed.

**1-11. HIGH/LOW Limit Alarms.** The ALARM function provides a means to monitor the power level in each channel independently. When the ALARM is "ON" (enabled) the level on the channel is continuously compared with the HI and LO Limit values. These limits are entered and treated as numerical values without regard to units. For example if you enter 10 for a limit while VOLT is selected in the units menu, the limit is 10 volts. If the units are then changed to dBm, the limit is now set at 10 dBm. The 9230 sets indicator flags (up and down arrows) on the channel display when the limit values are exceeded. There are 4 status bits in the service request byte which, when unmasked, can be used to request service over the IEEE-488 interface bus when the selected alarm condition occurs. Note that choosing overlapping limit

conditions is not an error, but may result in confusing alarm indications.

**1-12. ACCESSORIES.**

**1-13.** A Sensor Data Adapter for each installed channel along with the AC power cord is supplied with the 9230. One or more Boonton series 952000 series RF Voltage Probes is required and must be ordered separately. Probes are available with accessory kits and separately.

- a. 952063 Standard RF Probe Kit, 10 kHz to 1.2 GHz  
Includes: 952001 RF Probe  
95200201B 50 Ohm BNC(F) Adapter  
95200401A Probe tip  
95200501A 100:1 Voltage Divider  
41-2A Probe Cable, 5 ft (1.5m)
- b. 952064 Low Frequency Probe Kit, 10 Hz to 100 MHz  
Includes: 952016 Low Frequency RF Probe  
95200201B 50 Ohm BNC(F) Adapter  
95200401A Probe tip  
95205801A 100:1 Voltage Divider  
41-2A Probe Cable, 5 ft (1.5m)

- c. 952009 50 Ohm Voltage Sensor, 100 kHz to 2.5 GHz

Other available accessories include the following:

- d. Model 41-2A/10 Probe/Sensor Interconnecting Cable, 10 ft. (3m)
- e. Model 41-2A/20 Probe/Sensor Interconnecting Cable, 20 ft. (6m)
- f. Model 41-2A/50 Probe/Sensor Interconnecting Cable, 50 ft. (15m)
- g. Model 41-2A/100 Probe/Sensor Interconnecting Cable, 100 ft. (30m)
- h. Model 91-15A 50 Ohm Termination.
- i. Model 91-15A/1 75 Ohm Termination.
- j. 95004701A F/F Adapter, 41-2A, (for end-to-end connection of 41-2A Cables)
- k. 95004901A F/F Bulkhead Adapter (for end-to-end connection of 41-2A Cables)
- l. 95200301A 50 Ohm Type N Tee Adapter.
- m. 95200601B 75 Ohm BNC Adapter for use up to 500 MHz.

- n. 95200701A 75 Ohm Type N Tee Adapter.
- o. 95200801B Unterminated BNC Adapter (Female).
- p. 95201101A 50 Ohm Accessory Kit for 952001B RF Probe.  
Includes 95200301A, 95200501A, 95200801B,  
95201301A, 91-15A.
- r. 95201201A 75 Ohm Accessory Kit for 952001B RF Probe.  
Includes 95200501A, 95200701A, 95200801B,  
95201301A, 91-15A/1.
- s. 95201202A 75 Ohm Accessory Kit for 952001B Rf Probe.  
Includes 95200701A, 95200801B, 95201301A,  
91-15A/1.
- t. 95201301A Accessory Case.
- u. 95403001A Rack Mounting Kit for single or dual unit  
mounting.

**1-14. OPTIONS.** Applies to Model 9231 single channel and Model 9232 dual channel instruments with standard IEEE-488 interface.

- 01 Move sensor inputs to the rear panel location.
- 03 Replace the IEEE-488 interface with the RS-232 interface.
- 30 Extend the Warranty to 3 years.

**TABLE 1-1. PERFORMANCE SPECIFICATIONS**

| Parameter  | Specification  |                            |        |       |       |       |          |     |     |    |     |     |     |
|--|--|----------------------------|--------|-------|-------|-------|----------|-----|-----|----|-----|-----|-----|
| Voltage Range  | 200 $\mu$ V to 10 V in 8 ranges<br>(20 mV to 300V with 100:1 DIVIDER)  |                            |        |       |       |       |          |     |     |    |     |     |     |
| Voltage Display  | Voltage - 3 to 5 digits<br>Decibel   |                            |        |       |       |       |          |     |     |    |     |     |     |
| Decibel Range  | 90 dB in 8 ranges, measurements  |                            |        |       |       |       |          |     |     |    |     |     |     |
| Decibel Display  |  |                            |        |       |       |       |          |     |     |    |     |     |     |
| dBmV   | 0 dBmV=1 mV  |                            |        |       |       |       |          |     |     |    |     |     |     |
| dBV  | 0 dBV=1V   |                            |        |       |       |       |          |     |     |    |     |     |     |
| dBr  | Relative to any level, limited to $\pm 99.999$ dB  |                            |        |       |       |       |          |     |     |    |     |     |     |
| dBm  | 0 dBm=1mW calculated from $V^2/Z_0$ where $Z_0$ is the selected reference impedance  |                            |        |       |       |       |          |     |     |    |     |     |     |
| dBW  | 0 dBW= 1 W as above  |                            |        |       |       |       |          |     |     |    |     |     |     |
| $Z_0$ IMPEDANCE:   | Any selected reference value from 5 to 2500 $\Omega$   |                            |        |       |       |       |          |     |     |    |     |     |     |
| PEAK DISPLAY:  | 1.414 times VOLTAGE DISPLAY or 3.01 dB added to dB DISPLAY   |                            |        |       |       |       |          |     |     |    |     |     |     |
| RANGING:   | Autoranging, plus hold-on-range  |                            |        |       |       |       |          |     |     |    |     |     |     |
| REFERENCE dB OFFSET:   | Any offset can be selected to 0.001 dB resolution provided that the display range of $\pm 99.99$ dB is not exceeded  |                            |        |       |       |       |          |     |     |    |     |     |     |
| FREQUENCY RANGE:   | MODEL 952001B RF PROBE 100 kHz to 1.2 GHz<br>MODEL 952016 LF PROBE 10 Hz to 100 MHz<br>MODEL 952009 SENSOR 100 kHz to 2.5 GHz  |                            |        |       |       |       |          |     |     |    |     |     |     |
| WAVEFORM RESPONSE:   | RMS to 30 mV, calibrated in rms of a sinewave above 30 mV (RMS to 3V and 700 MHz with Divider)   |                            |        |       |       |       |          |     |     |    |     |     |     |
| CREST FACTOR:  | <table border="1"> <tr> <td><b>Direct Input:</b> Level</td> <td>300 mV</td> <td>1mV</td> <td>3mV</td> <td>10 mV</td> <td>30 mV</td> </tr> <tr> <td>CF</td> <td>140</td> <td>42</td> <td>14</td> <td>4.2</td> <td>1.4</td> </tr> </table> | <b>Direct Input:</b> Level | 300 mV | 1mV   | 3mV   | 10 mV | 30 mV    | CF  | 140 | 42 | 14  | 4.2 | 1.4 |
|  | <b>Direct Input:</b> Level   | 300 mV                     | 1mV    | 3mV   | 10 mV | 30 mV |          |     |     |    |     |     |     |
| CF   | 140  | 42                         | 14     | 4.2   | 1.4   |       |          |     |     |    |     |     |     |
| <table border="1"> <tr> <td><b>With Divider:</b> Level</td> <td>30 mV</td> <td>100 mV</td> <td>300mV</td> <td>1V</td> <td>3V</td> </tr> <tr> <td>100:1 CF</td> <td>140</td> <td>42</td> <td>14</td> <td>4.2</td> <td>1.4</td> </tr> </table> | <b>With Divider:</b> Level   | 30 mV                      | 100 mV | 300mV | 1V    | 3V    | 100:1 CF | 140 | 42  | 14 | 4.2 | 1.4 |     |
| <b>With Divider:</b> Level   | 30 mV  | 100 mV                     | 300mV  | 1V    | 3V    |       |          |     |     |    |     |     |     |
| 100:1 CF   | 140  | 42                         | 14     | 4.2   | 1.4   |       |          |     |     |    |     |     |     |
| INPUT IMPEDANCE:   | Refer to Fig. 1-2.   |                            |        |       |       |       |          |     |     |    |     |     |     |
| MAXIMUM AC INPUT:  | 10 V, all frequencies and ranges   |                            |        |       |       |       |          |     |     |    |     |     |     |

**TABLE 1-1. PERFORMANCE SPECIFICATIONS (CONT.)**

| <b>Parameter</b>                          | <b>Specification</b>  |
|---|---|
| MAXIMUM DC INPUT:<br><br>RECORDER OUTPUT: | 200 V, all ranges.<br><br>For linear voltage readout, 10 V full scale proportional to indicated voltage over each decade. Ranging occurs at 10% of full scale. For decibel readouts, scale factor is 1V per 10 dB change over the entire dynamic range. |

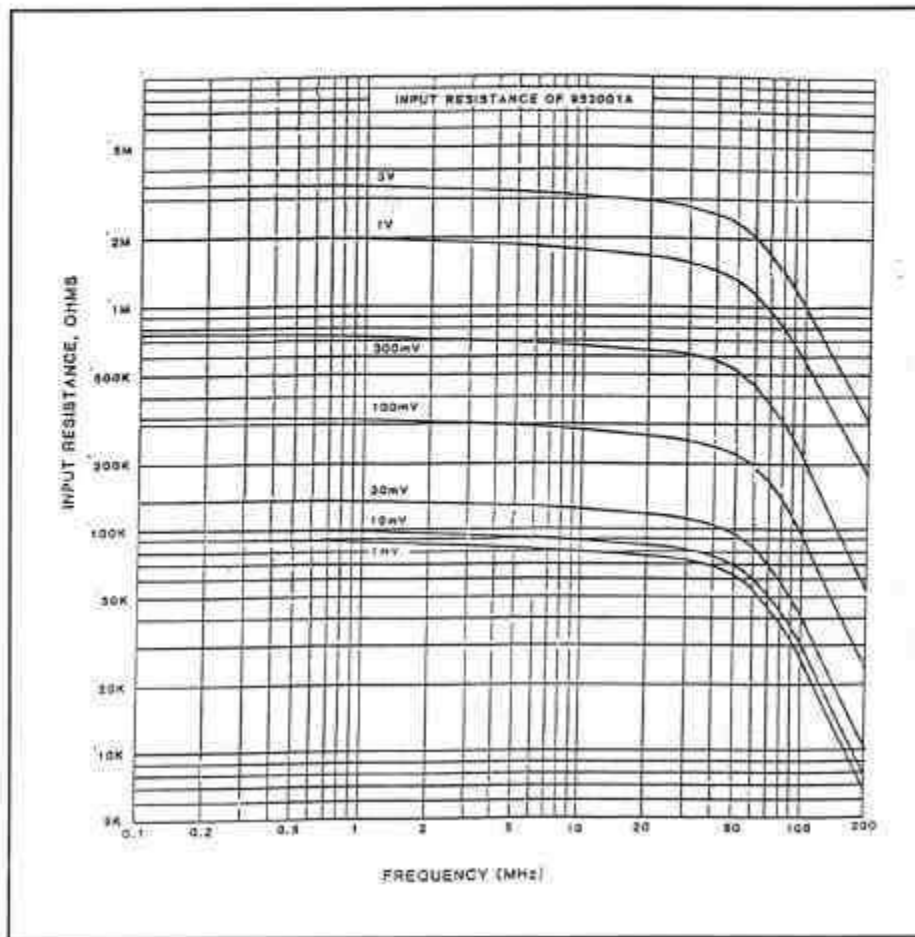

**INPUT RESISTANCE VS. FREQUENCY,  
MODEL 952001B**

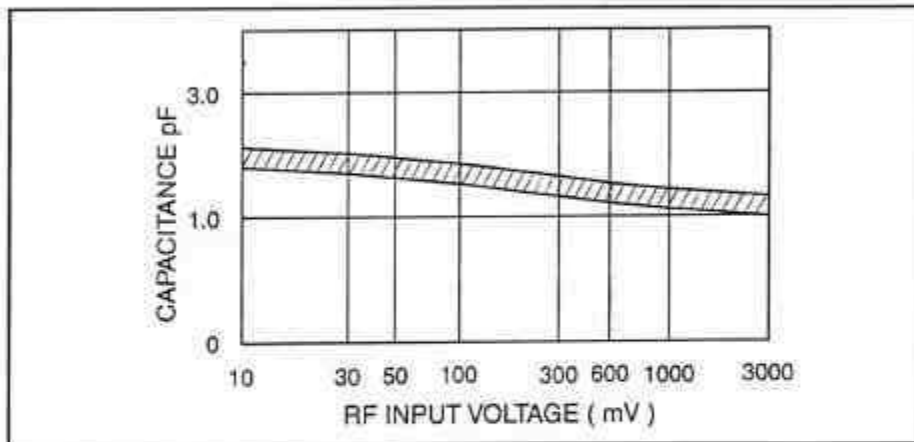

**INPUT CAPACITANCE VS. INPUT VOLTAGE,  
MODEL 952001B RF PROBE**

Figure1-2. Input Impedance

TABLE 1-1. PERFORMANCE SPECIFICATIONS (CONT.)

| Parameter  | Specification  |                   |     |     |     |     |     |     |    |    |    |    |     |     |     |     |     |     |     |     |   |    |    |     |     |     |     |     |     |    |   |    |    |    |     |     |     |     |     |     |     |     |     |    |    |           |    |                   |                  |   |   |                  |       |         |                 |       |         |                 |       |         |
|--|--|-------------------|-----|-----|-----|-----|-----|-----|----|----|----|----|-----|-----|-----|-----|-----|-----|-----|-----|---|----|----|-----|-----|-----|-----|-----|-----|----|---|----|----|----|-----|-----|-----|-----|-----|-----|-----|-----|-----|----|----|-----------|----|-------------------|------------------|---|---|------------------|-------|---------|-----------------|-------|---------|-----------------|-------|---------|
| <p><b>ACCURACY:</b></p> <p><b>1. Basic Uncertainty:</b></p> <p><b>2. Frequency Effect:</b></p> | <p>The maximum uncertainty is the sum of the</p> <ol style="list-style-type: none"> <li>1. BASIC UNCERTAINTY</li> <li>2. FREQUENCY EFFECT</li> <li>3. TEMPERATURE EFFECT</li> </ol> <p><b>UNCERTAINTY VS. INPUT LEVEL</b></p> <p>Voltage</p> <p>3 mV - 10 V    1%rdg ± 1 count</p> <p>1 mV - 3 mV    2%rdg ± 2 counts</p> <p>0.2 mV - 1 mV   3%rdg ± 3 counts</p> <p>FOR dBV, dBmV, dBm, and dBW</p> <div data-bbox="662 814 1455 1205" style="border: 1px solid black; padding: 5px;"> <table border="1" style="margin-top: 10px; width: 100%; text-align: center;"> <tr> <td>dBmV</td><td>-10</td><td>0</td><td>10</td><td>20</td><td>30</td><td>40</td><td>50</td><td>60</td><td>70</td><td>80</td> </tr> <tr> <td>dBV</td><td>-70</td><td>-60</td><td>-50</td><td>-40</td><td>-30</td><td>-20</td><td>-10</td><td>0</td><td>10</td><td>20</td> </tr> <tr> <td>dBm</td><td>-57</td><td>-47</td><td>-37</td><td>-27</td><td>-17</td><td>-7</td><td>3</td><td>13</td><td>23</td><td>33</td> </tr> <tr> <td>dBW</td><td>-87</td><td>-77</td><td>-67</td><td>-57</td><td>-47</td><td>-37</td><td>-27</td><td>-17</td><td>-7</td><td>+3</td> </tr> </table> </div> <p><b>MODEL 9230 UNCERTAINTY VS. INPUT LEVEL<br/>FOR dBV, dBmV, dBm, and dBW</b></p> <p>Model 952001B Probe with Model 952002 50Ω BNC Adapter or Model 952003 Tee Adapter.</p> <table border="1" style="width: 100%; text-align: center;"> <thead> <tr> <th>Frequency</th> <th>mV</th> <th>dBV,<br/>dBmV, dBm</th> </tr> </thead> <tbody> <tr> <td>1 MHz (cal freq)</td> <td>0</td> <td>0</td> </tr> <tr> <td>10 kHz - 100 MHz</td> <td>1%rdg</td> <td>0.09 dB</td> </tr> <tr> <td>100 MHz - 1 GHz</td> <td>3%rdg</td> <td>0.27 dB</td> </tr> <tr> <td>1 GHz - 1.2 GHz</td> <td>7%rdg</td> <td>0.63 dB</td> </tr> </tbody> </table> | dBmV              | -10 | 0   | 10  | 20  | 30  | 40  | 50 | 60 | 70 | 80 | dBV | -70 | -60 | -50 | -40 | -30 | -20 | -10 | 0 | 10 | 20 | dBm | -57 | -47 | -37 | -27 | -17 | -7 | 3 | 13 | 23 | 33 | dBW | -87 | -77 | -67 | -57 | -47 | -37 | -27 | -17 | -7 | +3 | Frequency | mV | dBV,<br>dBmV, dBm | 1 MHz (cal freq) | 0 | 0 | 10 kHz - 100 MHz | 1%rdg | 0.09 dB | 100 MHz - 1 GHz | 3%rdg | 0.27 dB | 1 GHz - 1.2 GHz | 7%rdg | 0.63 dB |
| dBmV   | -10  | 0                 | 10  | 20  | 30  | 40  | 50  | 60  | 70 | 80 |    |    |     |     |     |     |     |     |     |     |   |    |    |     |     |     |     |     |     |    |   |    |    |    |     |     |     |     |     |     |     |     |     |    |    |           |    |                   |                  |   |   |                  |       |         |                 |       |         |                 |       |         |
| dBV  | -70  | -60               | -50 | -40 | -30 | -20 | -10 | 0   | 10 | 20 |    |    |     |     |     |     |     |     |     |     |   |    |    |     |     |     |     |     |     |    |   |    |    |    |     |     |     |     |     |     |     |     |     |    |    |           |    |                   |                  |   |   |                  |       |         |                 |       |         |                 |       |         |
| dBm  | -57  | -47               | -37 | -27 | -17 | -7  | 3   | 13  | 23 | 33 |    |    |     |     |     |     |     |     |     |     |   |    |    |     |     |     |     |     |     |    |   |    |    |    |     |     |     |     |     |     |     |     |     |    |    |           |    |                   |                  |   |   |                  |       |         |                 |       |         |                 |       |         |
| dBW  | -87  | -77               | -67 | -57 | -47 | -37 | -27 | -17 | -7 | +3 |    |    |     |     |     |     |     |     |     |     |   |    |    |     |     |     |     |     |     |    |   |    |    |    |     |     |     |     |     |     |     |     |     |    |    |           |    |                   |                  |   |   |                  |       |         |                 |       |         |                 |       |         |
| Frequency  | mV   | dBV,<br>dBmV, dBm |     |     |     |     |     |     |    |    |    |    |     |     |     |     |     |     |     |     |   |    |    |     |     |     |     |     |     |    |   |    |    |    |     |     |     |     |     |     |     |     |     |    |    |           |    |                   |                  |   |   |                  |       |         |                 |       |         |                 |       |         |
| 1 MHz (cal freq)   | 0  | 0                 |     |     |     |     |     |     |    |    |    |    |     |     |     |     |     |     |     |     |   |    |    |     |     |     |     |     |     |    |   |    |    |    |     |     |     |     |     |     |     |     |     |    |    |           |    |                   |                  |   |   |                  |       |         |                 |       |         |                 |       |         |
| 10 kHz - 100 MHz   | 1%rdg  | 0.09 dB           |     |     |     |     |     |     |    |    |    |    |     |     |     |     |     |     |     |     |   |    |    |     |     |     |     |     |     |    |   |    |    |    |     |     |     |     |     |     |     |     |     |    |    |           |    |                   |                  |   |   |                  |       |         |                 |       |         |                 |       |         |
| 100 MHz - 1 GHz  | 3%rdg  | 0.27 dB           |     |     |     |     |     |     |    |    |    |    |     |     |     |     |     |     |     |     |   |    |    |     |     |     |     |     |     |    |   |    |    |    |     |     |     |     |     |     |     |     |     |    |    |           |    |                   |                  |   |   |                  |       |         |                 |       |         |                 |       |         |
| 1 GHz - 1.2 GHz  | 7%rdg  | 0.63 dB           |     |     |     |     |     |     |    |    |    |    |     |     |     |     |     |     |     |     |   |    |    |     |     |     |     |     |     |    |   |    |    |    |     |     |     |     |     |     |     |     |     |    |    |           |    |                   |                  |   |   |                  |       |         |                 |       |         |                 |       |         |



**TABLE 1-1. PERFORMANCE SPECIFICATIONS (CONT.)**

| Parameter   | Specification  |                          |                          |
|---|--|--------------------------|--------------------------|
| <b>2. Frequency Effect:<br/>(Continued)</b>                                     | <b>Model 952003 Tee Adapter</b><br>1.2 GHz - 2.0 GHz 7% $\pm$ .01% mV<br><br>SWR: 1.05 to 300MHz, 1.10 to 1GHz, 1.15 to 1.2GHz |                          |                          |
|   | <b>Model 952009 Terminated Voltage Sensor.</b>   |                          |                          |
|   | <b>Frequency</b>   | <b>mV</b>                | <b>dBV,<br/>dBmV,dBm</b> |
|   | 1 MHz (cal freq)   | 0                        | 0                        |
|   | 100kHz - 1 GHz   | 1%rdg                    | 0.09 dB                  |
|   | 1 GHz - 2GHz   | 3%rdg                    | 0.27 dB                  |
|   | 2GHz-2.5GHz  | 5%rdg                    | 0.45 dB                  |
|   | SWR: 1.05 to 2GHz, 1.10 to 2.5GHz  |                          |                          |
|   | <b>Model 952016 Low Frequency Probe with Model 952002 BNC Adapter.</b>   |                          |                          |
|   | <b>Frequency</b>   | <b>mV</b>                | <b>dBV,<br/>dBmV,dBm</b> |
| 1 MHz (cal freq)  | 0  | 0                        |                          |
| 50Hz - 20MHz  | 1%rdg  | 0.09 dB                  |                          |
| 20Hz - 50Hz   | 2%rdg  | 0.17 dB                  |                          |
| 10Hz - 100MHz   | 5%rdg  | 0.45 dB                  |                          |
| SWR: 1.05 to 100MHz   |  |                          |                          |
| <b>Model 952001B Probe with Model 952006 75<math>\Omega</math> BNC Adapter.</b> |  |                          |                          |
| <b>Frequency</b>  | <b>mV</b>  | <b>dBV,<br/>dBmV,dBm</b> |                          |
| 1 MHz (cal freq)  | 0  | 0                        |                          |
| 10kHz - 100mHz  | 1%rdg  | 0.09 dB                  |                          |
| 100MHz - 300MHz   | 3%rdg  | 0.27 dB                  |                          |
| 300MHz - 500MHz   | 6%rdg  | 0.54 dB                  |                          |
| SWR: 1.05 to 150MHz, 1.10 to 300MHz, 1.20 to 500MHz                             |  |                          |                          |

**TABLE 1-1. PERFORMANCE SPECIFICATIONS (CONT.)**

| Parameter   | Specification   |  |  |                  |  |  |    |  |                |  |                  |      |                  |      |                  |         |   |   |   |   |         |   |       |   |         |         |       |       |         |         |        |       |       |         |         |
|---|---|--|--|------------------|--|--|----|--|----------------|--|------------------|------|------------------|------|------------------|---------|---|---|---|---|---------|---|-------|---|---------|---------|-------|-------|---------|---------|--------|-------|-------|---------|---------|
| <b>2. Frequency Effect:<br/>(Continued)</b>   | <b>Model 952001B Probe with Model 952007 75Ω Tee Adapter.</b><br><b>dBV,<br/>mV, dBmV, dBm</b>  |  |  |                  |  |  |    |  |                |  |                  |      |                  |      |                  |         |   |   |   |   |         |   |       |   |         |         |       |       |         |         |        |       |       |         |         |
|   | <b>Frequency</b><br><br>1 MHz (cal freq)<br>10kHz - 100MHz<br>100MHz - 700MHz<br>700MHz - 1 GHz<br><br>SWR: 1.05 to 150MHz, 1.10 to 750MHz, 1.25 to 1 GHz | <b>mV</b><br><br>0<br>1%rdg<br>3%rdg<br>7%rdg                | <b>dBV,<br/>dBmV, dBm</b><br><br>0<br>0.09dB<br>0.27dB<br>0.63dB             |                  |  |  |    |  |                |  |                  |      |                  |      |                  |         |   |   |   |   |         |   |       |   |         |         |       |       |         |         |        |       |       |         |         |
| <b>3. Temperature Effect:</b>   | <b>Model 952016 Low Frequency Probe with Model 952058<br/>100:1 Divider.</b><br><b>dBV,<br/>mV, dBmV, dBm</b>   |  |  |                  |  |  |    |  |                |  |                  |      |                  |      |                  |         |   |   |   |   |         |   |       |   |         |         |       |       |         |         |        |       |       |         |         |
|   | <b>Frequency</b><br><br>1 MHz (cal freq)<br>1MHz - 20 MHz<br>50Hz - 1 MHz<br>20Hz - 50Hz<br>10Hz - 20Hz   | <b>mV</b><br><br>0<br>5%rdg<br>3.5%rdg<br>4.5%rdg<br>7.5%rdg | <b>dBV,<br/>dBmV, dBm</b><br><br>0<br>0.45 dB<br>0.31dB<br>0.40dB<br>0.68 dB |                  |  |  |    |  |                |  |                  |      |                  |      |                  |         |   |   |   |   |         |   |       |   |         |         |       |       |         |         |        |       |       |         |         |
| <b>Model 952001B Probe or Model 952009 Sensor at<br/>10 kHz to 1.2 GHz.</b>   |   |  |  |                  |  |  |    |  |                |  |                  |      |                  |      |                  |         |   |   |   |   |         |   |       |   |         |         |       |       |         |         |        |       |       |         |         |
| <table border="1"> <thead> <tr> <th data-bbox="760 1329 927 1381"></th> <th colspan="2" data-bbox="927 1329 1138 1381">mV</th> <th colspan="2" data-bbox="1138 1329 1541 1381">dBV, dBmV, dBm</th> </tr> <tr> <th data-bbox="760 1381 927 1455">Temp<br/>Degree C</th> <th data-bbox="927 1381 992 1455">Inst</th> <th data-bbox="992 1381 1138 1455">Probe/<br/>Sensor</th> <th data-bbox="1138 1381 1219 1455">Inst</th> <th data-bbox="1219 1381 1541 1455">Probe/<br/>Sensor</th> </tr> </thead> <tbody> <tr> <td data-bbox="760 1455 927 1497">21 - 25</td> <td data-bbox="927 1455 992 1497">0</td> <td data-bbox="992 1455 1138 1497">0</td> <td data-bbox="1138 1455 1219 1497">0</td> <td data-bbox="1219 1455 1541 1497">0</td> </tr> <tr> <td data-bbox="760 1497 927 1539">18 - 30</td> <td data-bbox="927 1497 992 1539">0</td> <td data-bbox="992 1497 1138 1539">1%rdg</td> <td data-bbox="1138 1497 1219 1539">0</td> <td data-bbox="1219 1497 1541 1539">0.09 dB</td> </tr> <tr> <td data-bbox="760 1539 927 1581">10 - 40</td> <td data-bbox="927 1539 992 1581">1%rdg</td> <td data-bbox="992 1539 1138 1581">3%rdg</td> <td data-bbox="1138 1539 1219 1581">0.09 dB</td> <td data-bbox="1219 1539 1541 1581">0.26 dB</td> </tr> <tr> <td data-bbox="760 1581 927 1623">0 - 55</td> <td data-bbox="927 1581 992 1623">2%rdg</td> <td data-bbox="992 1581 1138 1623">7%rdg</td> <td data-bbox="1138 1581 1219 1623">0.18 dB</td> <td data-bbox="1219 1581 1541 1623">0.63 dB</td> </tr> </tbody> </table> |   |  |  |                  |  |  | mV |  | dBV, dBmV, dBm |  | Temp<br>Degree C | Inst | Probe/<br>Sensor | Inst | Probe/<br>Sensor | 21 - 25 | 0 | 0 | 0 | 0 | 18 - 30 | 0 | 1%rdg | 0 | 0.09 dB | 10 - 40 | 1%rdg | 3%rdg | 0.09 dB | 0.26 dB | 0 - 55 | 2%rdg | 7%rdg | 0.18 dB | 0.63 dB |
|   | mV  |  | dBV, dBmV, dBm   |                  |  |  |    |  |                |  |                  |      |                  |      |                  |         |   |   |   |   |         |   |       |   |         |         |       |       |         |         |        |       |       |         |         |
| Temp<br>Degree C  | Inst  | Probe/<br>Sensor   | Inst   | Probe/<br>Sensor |  |  |    |  |                |  |                  |      |                  |      |                  |         |   |   |   |   |         |   |       |   |         |         |       |       |         |         |        |       |       |         |         |
| 21 - 25   | 0   | 0  | 0  | 0                |  |  |    |  |                |  |                  |      |                  |      |                  |         |   |   |   |   |         |   |       |   |         |         |       |       |         |         |        |       |       |         |         |
| 18 - 30   | 0   | 1%rdg  | 0  | 0.09 dB          |  |  |    |  |                |  |                  |      |                  |      |                  |         |   |   |   |   |         |   |       |   |         |         |       |       |         |         |        |       |       |         |         |
| 10 - 40   | 1%rdg   | 3%rdg  | 0.09 dB  | 0.26 dB          |  |  |    |  |                |  |                  |      |                  |      |                  |         |   |   |   |   |         |   |       |   |         |         |       |       |         |         |        |       |       |         |         |
| 0 - 55  | 2%rdg   | 7%rdg  | 0.18 dB  | 0.63 dB          |  |  |    |  |                |  |                  |      |                  |      |                  |         |   |   |   |   |         |   |       |   |         |         |       |       |         |         |        |       |       |         |         |

**TABLE 1-1. PERFORMANCE SPECIFICATIONS (CONT.)**

| Parameter              | Specification  |
|------------------------|--|
| <b>LINE STABILITY:</b> | Less than 0.2% rdg with $\pm 10\%$ line voltage change at reference line conditions of 115 to 120 V, 50 to 400 Hz  |
| <b>ZERO:</b>           | Automatic, operated by panel key switch.   |
| <b>DISPLAY:</b>        | 4 line by 20 character LCD with LED backlight.   |
| <b>ENVIRONMENTAL:</b>  | Conforms to the requirements of Mil-T28800C for Type 11, Class 5, Style E equipment  |
| <b>CE MARK</b>         | Conformity to European Community (EC)<br>Council Directives: 89/336/EEC//93/68/EEC, 73/23/EEC//93/68/EEC & Standards:<br>EN61326-1, EN61000-4/-2, 3, 4, 5, 6, 11, EN55022, EN61010-1 |
| <b>POWER:</b>          | 100, 120, 220, 240, V $\pm 10\%$ , 50-100 Hz, 15 VA  |
| <b>TEMPERATURE:</b>    | Operating: 0 to +55°C<br>Non-operating: -10 to -75 °C  |
| <b>ALTITUDE:</b>       | Operating: 10,000 ft   |
| <b>HUMIDITY:</b>       | 95% (Non-condensing)   |
| <b>WEIGHT:</b>         | 7 lbs (3.2 kg)   |
| <b>DIMENSIONS:</b>     | 8.26 in . (21.0 cm) wide, 3.48 in. (8.9 cm ) high, 13.5 in. (34.3 cm) deep   |

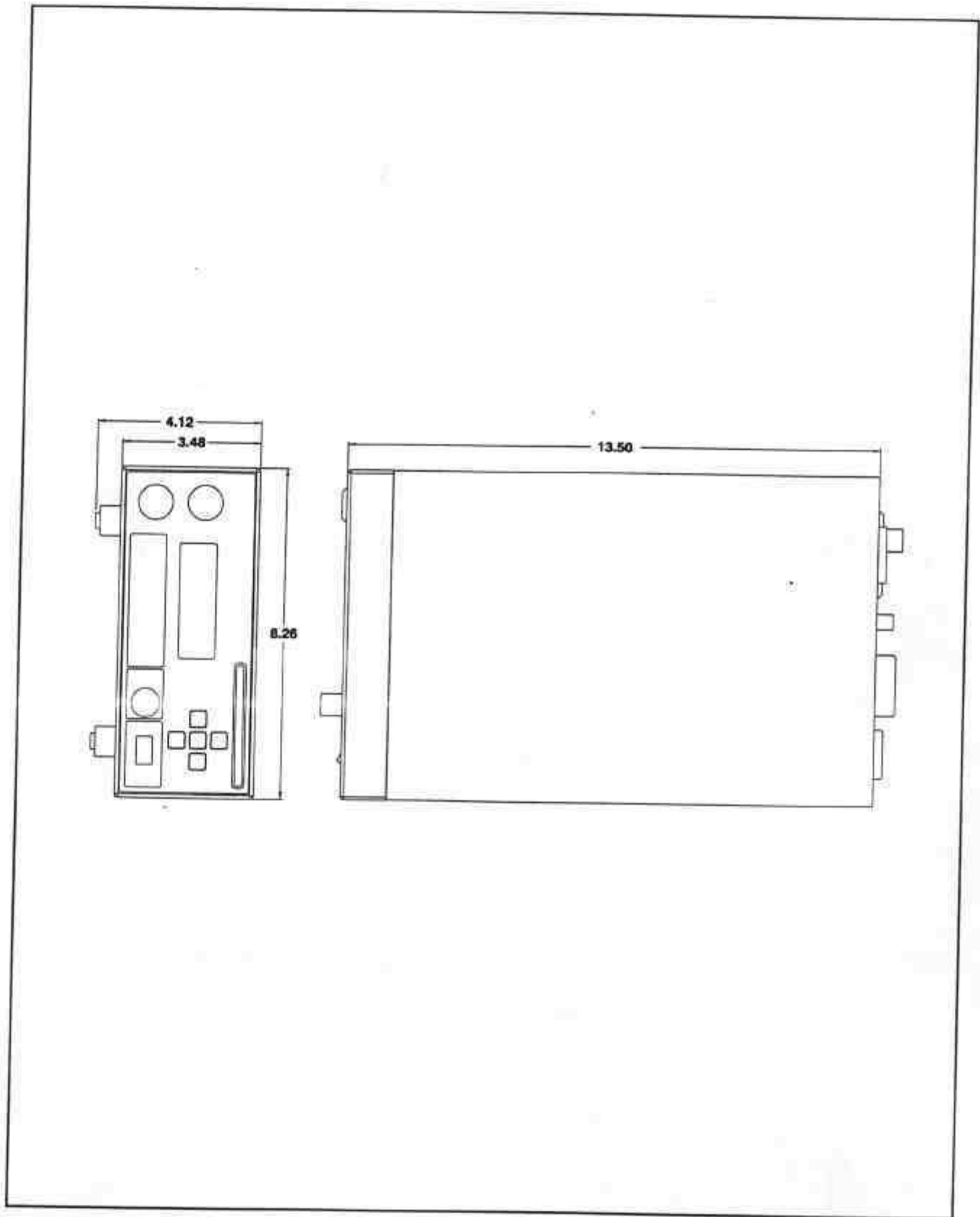

Figure 1-3. Outline Dimensions

## SECTION II INSTALLATION

### 2-1. INTRODUCTION.

This section contains the installation instructions for the Model 9230 Series RF Voltmeter. It includes unpacking, mounting, power connections, cable connections and preliminary checkout procedures.

**2-2. UNPACKING.** The instrument is shipped complete and ready to use upon receipt. Unpack the instrument from its shipping container and inspect it for damage that may have occurred during shipment. Refer to figure 2-1.

#### NOTE

Save the packing material and container for possible use in re-shipment of the instrument.

**2-3. MOUNTING.** For bench use, choose a clean, dry and uncluttered surface. For rack mounting, an accessory kit is available which contains the necessary parts for mounting a single half-width Model 9230 or two side-by-side half-width Model 9230's (or a compatible product) in a single 19 inch rack.

**2-4. POWER REQUIREMENTS.** The Model 9230 has a tapped transformer and a power entry module containing a line voltage selector switch and two fuses. Operation is permitted from 100, 120, 220 and 240 Volt  $\pm 10\%$ , 50 to 60 Hz, single phase AC power supplies.



Always make certain that the setting of the line voltage selector switch most nearly corresponds to the voltage of the AC power source, and that fuses of the correct rating according to the chart just above the power entry module, are installed.

To change the line voltage selector switch or the fuses, follow this procedure:

1. REMOVE the power cable from the power entry module.
2. To open the power entry module, place a small screwdriver or coin in the slot at the top of the module and gently pry the cover open.
3. Using a small screwdriver gently pry the voltage selector cylinder from the module. Turn the cylinder

so that when it is re-inserted into the module, the desired voltage will appear in the small window in the cover.

4. To remove the fuses, move the fuseholder tabs in the direction of the arrow and pull the holder out. Place a new fuse in the holder and put it back in the slot, restoring the tab to its original position.

5. After all changes are completed, close the cover. Make sure the alignment of the selector cylinder and window is correct and that the cover snaps into place.

| VOLTAGE  | FUSE   | IEC TYPE |
|----------|--------|----------|
| 100/120V | 0.315A | T        |
| 220/240V | 0.160A | T        |

**2-5. CONNECTIONS.** An AC power cable is supplied with the instrument and a standard interconnecting cable or cable/adaptor combination is supplied with each RF Probe. Longer RF Probe cables are available as accessories. All other cables required must be supplied by the user.

**2-6. Sensor.** Connect the RF Probe that is to be used for measurement to the cable or Data Adapter-Cable combo supplied with the sensor. If the Data Adapter is a separate item, also connect the cable to the adapter. Make sure that the serial number on the Data Adapter matches the serial number of the RF Probe. Insert the 10-pin adapter plug into one of the two sensor inputs. For Model 9231, only Sensor input number 1 is active.

**2-7. Recorder.** A data recorder or other similar device can be connected to the Recorder BNC connector on the rear panel. The output is a DC voltage proportional to the Channel 1 display value. The voltage range is 0 to 10 volts with an output impedance of approximately 9 kohms.

**2-8. GPIB.** The standard instrument is equipped with an IEEE-488 bus interface for remote operation. The connector is located on the rear panel.

**2-9. RS-232.** The optional RS-232 interface can be supplied in place of the standard IEEE-488 interface. This interface also provides remote operation using the same command strings. The DB-25 connector is located on the rear panel.

## 2-10. PRELIMINARY CHECK.

**2-11.** The following preliminary check verifies that the Model 9230 is operational. It should be performed before the instrument is placed in service. Proceed as follows:

a. Ensure that the voltage selector switch and fuses correspond to the AC power source voltage to be used.

b. Connect the AC power cable to the instrument and to the power source.

c. Connect one or two RF Probes to the instrument as described above.

d. Set the front panel OFF/ON power switch to the ON position..

e. Verify that

```
BOONTONELECTRONICS
923X RFLVOLTMMETER
Rev. X.XX
```

is momentarily displayed.

f. Verify that the measurement display showing "CH 1" only for Model 9231 or "CH 1" and "CH 2" for Model 9232. Other data on the display will depend upon previous settings.

g. Press the <MENU> key and select DIAGNOSTICS with the down arrow key. Press <ENTER>. Verify the following sub-menu:

```
DIAGNOSTICS
  RTN
  SELFTST <
  SWITCHES
  RECORDER
```

h. Press <ENTER> to execute the selftest. The items tested are:

1. Processor
2. SRAM Memory
3. EEPROM

Each test will display the OK message if it passed. When the test is completed the menu will reappear.

i. Use the <Down Arrow> key to move the "<" cursor to SWITCHES and press <ENTER>. Press each front panel key, avoiding <MENU> until last. Each key press will result in an identifying message; <MENU> will exit the test and return to the MENU.

j. Use the <Down Arrow> key to select RECORDER and press <ENTER>. This test will sequentially send a DC voltage in 1 volt steps to the recorder output BNC connector on the rear panel. The test will continue until <MENU> is pressed. Use a DC voltmeter to verify correct operation.

k. Press <MENU> to return to the measurement display.

l. Press the <Sensor> key and verify that the RF Probe serial number(s) appear under the channel heading(s). An active channel with no probe installed will report a table number.

m. Press the <AVG> key and verify that the filter time and number of samples appear for each active channel.

n. Press the <REF Level> key and verify that a reference level and mode is shown for each active channel.

o. With all installed RF Probes disconnected from any source of RF voltage, press the <ZERO> key and select the ZERO function for each active channel and probe in turn. Verify that the zeroing operation is successfully completed for each active channel and each RF Probe.

p. For standard instruments equipped with the IEEE-488 interface, connect a GPIB controller to the Model 9230. Verify that the instrument can be addressed to Listen at its IEEE bus address, and set to Remote. The display must show the correct status on the bottom line of the display. For message passing, the line terminators for the controller and the Model 9230 must be compatible for both Listen and Talk. Use <MAIN> <SETUP> <IEEE> to set address and terminators for the 9230. Address the 9230 to Listen/Remote and send the command "?ID" or "\*IDN?" EOL. Then address the Model 9230 to Talk (controller to listen) and verify that the correct identification string is returned.

q. For instruments equipped with the optional RS-232 interface, connect a dumb terminal or PC serial terminal to the Model 9230. Use a null modem if the terminal is wired as DCE. For message communication to take place, the parameters of the serial connection and message strings must agree between the terminal and the Model 9230. Use <MAIN> <SETUP> <RS-232> to set parameters for the 9230. Send the command "?ID" or "\*IDN?" EOL and verify that the correct identification string is returned.

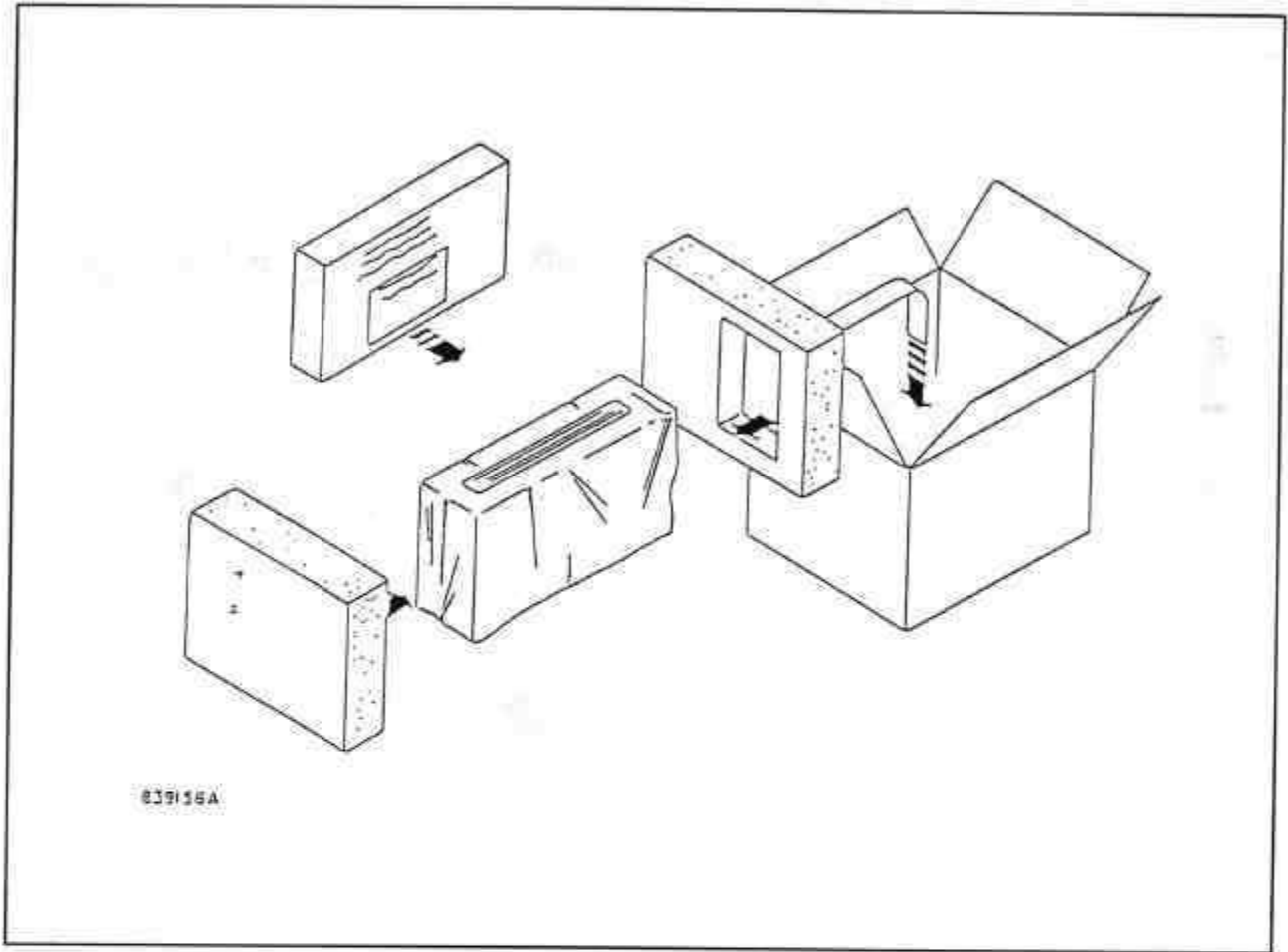

Figure 2-1. Packing and Unpacking Diagram

## SECTION III OPERATION

### 3-1. INTRODUCTION.

**3-2.** This section contains operating instructions for the Model 9230. It is strongly recommended that the operator become familiar with all the material in this section and with the application notes in Section IV before attempting to operate the instrument; otherwise, the full capabilities of the instrument may not be realized.

### 3-3. OPERATING CONTROLS, INDICATORS, AND CONNECTORS.

**3-4.** See Figures 3-1 and 3-2 for the location of the operating controls and connectors. Refer to Table 3-1 for the function of each of these items.

### 3-5. OPERATING THE INSTRUMENT.

**3-6.** Energize the instrument by setting the OFF/ON switch to the ON position. The instrument will perform a self test routine and initialize the operating parameters to the power-up values.

### 3-7. MEASUREMENT DISPLAY.

**3-8.** The measurement screen shown in Figure 3-3 can be configured to display one or two channels along with the corresponding bar graph. In alarm mode, the  $\wedge$  and the  $\vee$  symbols are displayed before the channel mode to indicate that the measured value is above or below the defined limits. An asterisk is displayed before the channel mode when in the manual range mode and the measured value is below the lower range limit indicating an uncalibrated measurement. The alarm indicators have precedence over the range limit display. In peak mode, the  $P_K$  symbol is displayed after the measurement unit. The  $\Delta$  symbol is displayed when the measurement is associated with an offset. When the instrument is configured for remote operations over the IEEE-488 or RS-232 bus, the last line, as shown in Figure 3-4, is always used for the bus indicators.

### 3-9. MENU STRUCTURE.

**TABLE 3-1. OPERATING CONTROLS, INDICATORS, AND CONNECTORS**

| Index and Fig. No. | Nomenclature                | Function  |
|--------------------|-----------------------------|---|
| 1, 3-1             | Sensor Connector, Channel 1 | Provides the means for connecting the voltage sensor to channel 1 of the instrument.  |
| 2, 3-1             | Sensor Connector, Channel 2 | Provides the means for connecting the voltage sensor to channel 2 of the instrument.  |
| 3, 3-1             | Display                     | LCD readout of the measurements and user interface for editing of the instrument's operating parameters.  |
| 4, 3-1             | Left Arrow Key              | In entry mode, advances the cursor to the left.   |
| 5, 3-1             | Up Arrow Key                | In entry mode, advances the cursor upwards. In parameter entry mode, scrolls forward through the parameter list. In numerical entry mode, advances the value to the next higher digit.    |
| 6, 3-1             | Enter Key                   | In entry mode, initiates the procedure to change a parameter. In parameter entry mode, terminates the current command and changes the parameter to the last displayed value.              |
| 7, 3-1             | Right Arrow Key             | In entry mode, advances the cursor to the right.  |
| 8, 3-1             | Down Arrow Key              | In entry mode, advances the cursor downwards. In parameter entry mode, scrolls backwards through the parameter list. In numerical entry mode, advances the value to the next lower digit. |
| 9, 3-1             | Power Switch                | Turns the instrument off and on.  |



**TABLE 3-1. OPERATING CONTROLS, INDICATORS, AND CONNECTORS (CONT.)**

| <b>Index and Fig. No.</b> | <b>Nomenclature</b>                              | <b>Function</b>   |
|---------------------------|--|---|
| 11, 3-1                   | <REF Level> Key                                  | Selects the reference level menu for relative measurements.   |
| 12, 3-1                   | <Zero> Key                                       | Selects the zeroing function.   |
| 13, 3-1                   | <AVG> Key  | Selects the filter averaging display for the measurement value.   |
| 14, 3-1                   | <FREQ> Key                                       | Not used.   |
| 15, 3-1                   | <Sensor> Key                                     | Displays the serial number of the installed sensors and allows for editing of the sensor parameters.  |
| 16, 3-1                   | <Menu> Key                                       | Displays and allows editing of the instrument's operating parameters. Returns instrument to local mode when operating in the bus remote mode. Escapes back to measurement screen from any menu. |
| 17,3-2                    | Power Entry Module with receptacle, and fuse     | Provides means for connecting the AC power cord to the instrument.  |
| 18,3-2                    | Fuse   | Protects the power circuits from overload.  |
| 19,3-2                    | Voltage Selector Switch                          | Switches the power circuits of the instrument to accommodate 100, 120, 220 or 240 volt AC power sources.  |
| 20, 3-2                   | GPIB Connector or RS-232                         | Provides means for connecting the instrument to the IEEE-488 or RS-232 bus for remote operation.  |
| 21, 3-2                   | Recorder Connector                               | Provides a DC voltage proportional to the measured values for use by an external recorder.  |
| 24,3-2                    | Optional location of Sensor Connector, Channel 1 | Provides the means for connecting the power sensor to channel 1 of the instrument.  |
| 25,3-2                    | Optional location of Sensor Connector, Channel 2 | Provides the means for connecting the power sensor to channel 2 of the instrument.  |

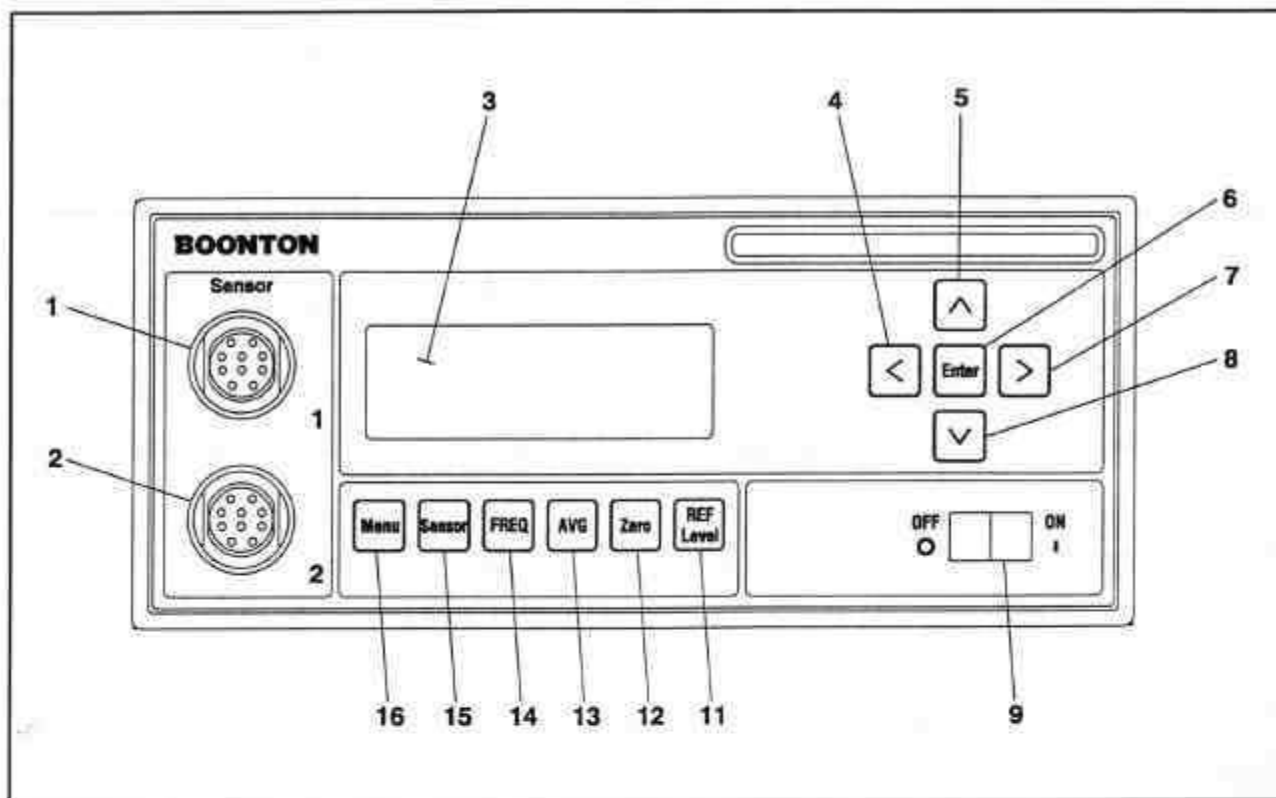

Figure 3-1. Model 9230, Front Panel Controls and Connectors.

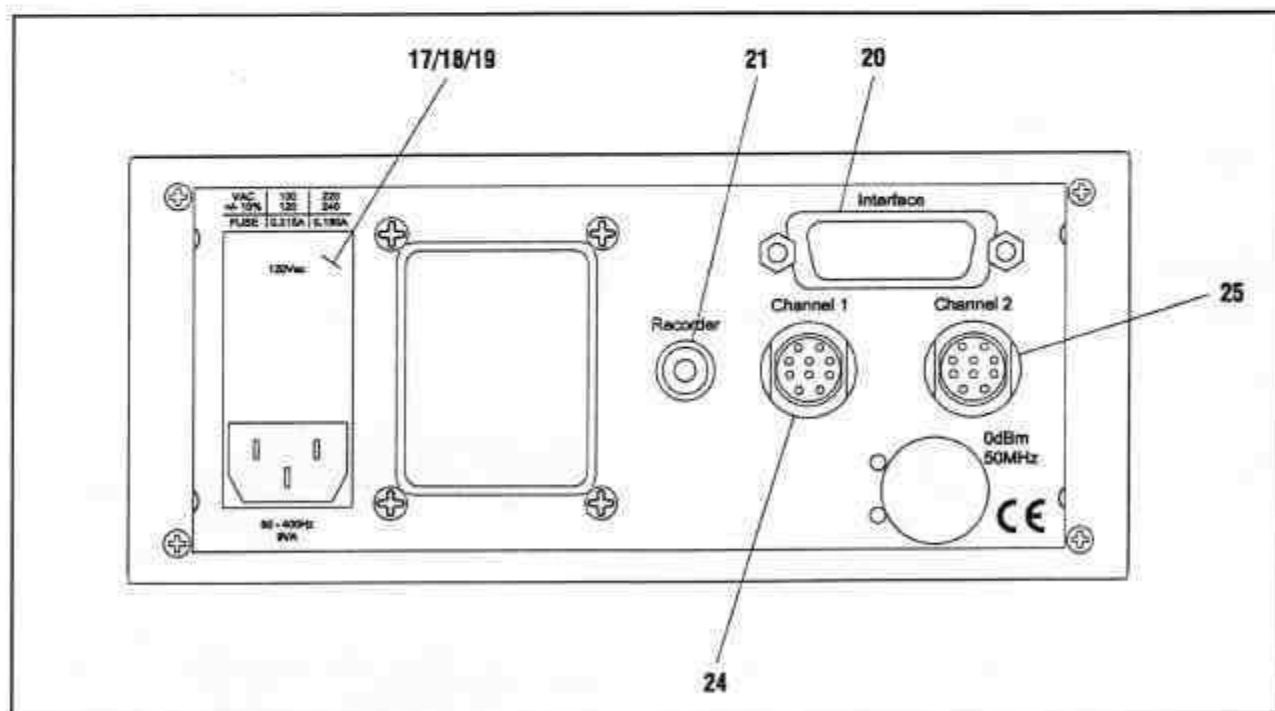

Figure 3-2. Model 9230, Rear Panel Controls and Connectors

## Section III Operation

**3-10.** The Model 9230 can be configured for operation via the six switches on the front panel; <Menu>, <Sensor>, <FREQ>, <AVG>, <Zero> and <REF Level>. Pressing a key will bring the instrument to the next submenu. A flow chart of the instrument's command structure is shown in Figure 3-5. The <Menu> key also serves as an ESCAPE key to cancel the current operation from any point and return to the measurement screen.

**3-11.** To change a value, use the arrow keys to position the cursor to the desired parameter. Press the <Enter> key and then use the up/down arrow keys to scroll through the parameter list. When a number is to be entered, use the left/right arrow keys to position the cursor under the number that is to be changed, then use the <Up/Down Arrow> keys to increment/decrement the number. Holding the up/down

arrow key will initiate repeat mode to allow rapid movement through the selections. The <Enter> key must be pressed to accept the current selection.

**3-12.** Within a submenu, the ^v indicators are displayed in the upper right portion of the display when the current screen has additional information that can be obtained by scrolling with the up/down arrow keys. Three conditions are possible:

a.^ Use the <Up Arrow> key to scroll the screen upward for additional information.

b.v Use the <Down Arrow> key to scroll the screen downward for additional information.

c.^v Use the <Up/Down Arrow> keys to scroll the screen upward/downward for additional information.

**DUAL CHANNEL**

|   |   |   |   |   |   |   |   |   |   |   |   |   |   |   |   |   |  |                |   |
|---|---|---|---|---|---|---|---|---|---|---|---|---|---|---|---|---|--|----------------|---|
| L | M | M | M | M | M |   | ± | D | D | D | D | D | D | U | U | U |  | P <sub>K</sub> | Δ |
|   |   |   |   | ( | B | A | R |   | G | R | A | P | H | ) |   |   |  |                |   |
| L | M | M | M | M | M |   | ± | D | D | D | D | D | D | U | U | U |  | P <sub>K</sub> | Δ |
|   |   |   |   | ( | B | A | R |   | G | R | A | P | H | ) |   |   |  |                |   |

**SINGLE CHANNEL**

|   |   |   |   |   |   |   |   |   |   |   |   |   |   |   |   |   |  |                |   |
|---|---|---|---|---|---|---|---|---|---|---|---|---|---|---|---|---|--|----------------|---|
| L | M | M | M | M | M |   | ± | D | D | D | D | D | D | U | U | U |  | P <sub>K</sub> | Δ |
|   |   |   |   | ( | B | A | R |   | G | R | A | P | H | ) |   |   |  |                |   |
|   |   |   |   |   |   |   |   |   |   |   |   |   |   |   |   |   |  |                |   |
|   |   |   |   |   |   |   |   |   |   |   |   |   |   |   |   |   |  |                |   |

- Key:**
- O = 0 through 9 or a decimal point
  - L = ^, v, (alarm mode), \* (range hold-low)
  - MMMMM = CH1, CH2, CH1+2, CH1/2
  - UUU = V, mV, μV, dBm, dBw, dBmV, dBV, %, dBr

**Figure 3-3. Measurement Display, Local Mode**

|   |   |   |   |   |   |   |   |   |   |   |   |   |   |   |   |   |   |                |   |
|---|---|---|---|---|---|---|---|---|---|---|---|---|---|---|---|---|---|----------------|---|
| L | M | M | M | M | M |   | ± | D | D | D | D | D | D | U | U | U |   | P <sub>K</sub> | Δ |
|   |   |   |   | ( | B | A | R |   | G | R | A | P | H | ) |   |   |   |                |   |
| L | M | M | M | M | M |   | ± | D | D | D | D | D | D | U | U | U |   | P <sub>K</sub> | Δ |
|   | R | E | M |   |   | L | S | N |   |   | T | L | K |   |   | S | R | Q              |   |

- Key:**
- REM = Remote mode enabled
  - LSN = Listen addressed
  - TLK = Talker addressed
  - SRQ = Service request activated

**Figure 3-4. Measurement Display, Remote Mode**

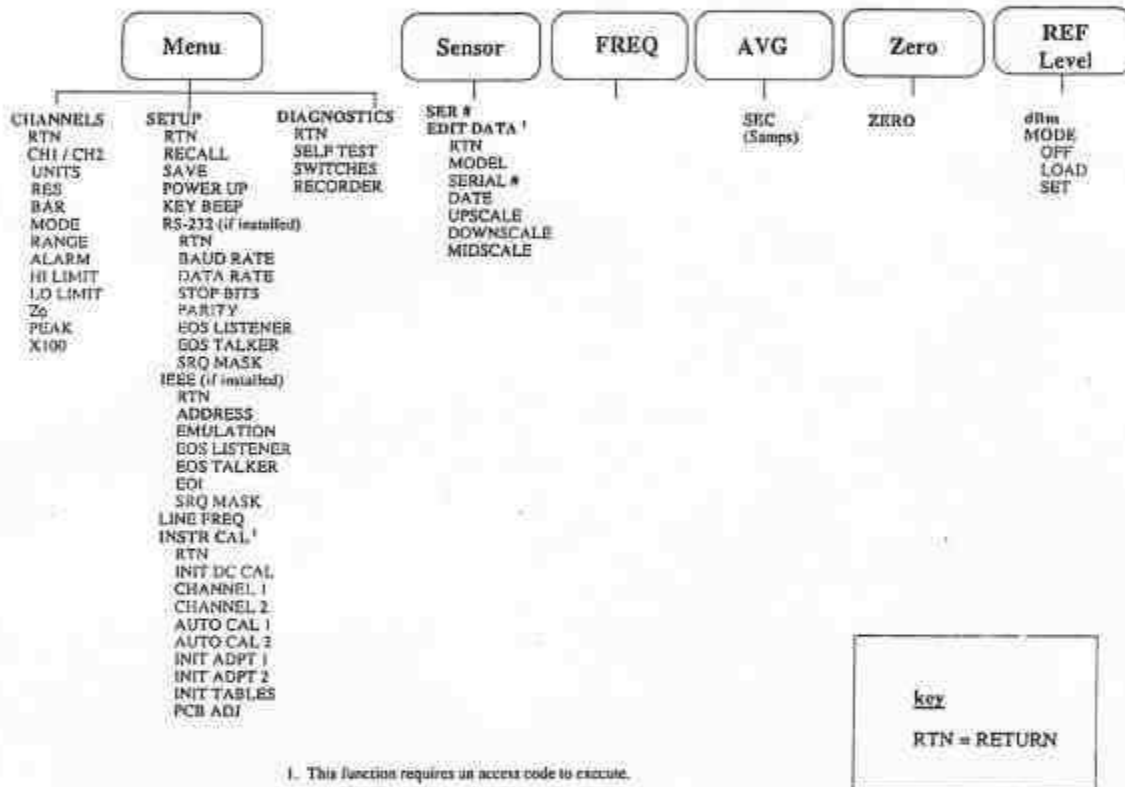

Figure 3-5. Model 9230, Command Set



**TABLE 3-2. CHANNEL MENU FUNCTIONS <MENU> < CHANNELS>**

| Function | Description   | Parameters   | Default |
|----------|---|--|---------|
| RTN      | Returns the instrument to the previous menu.  | n/a  | n/a     |
| UNITS    | Units used for measurement display.   | dBm, VOLTS, dBV, dBmV, dBW                         | dBm     |
| RES      | Display resolution  | X.X, X.XX, X.XXX decibel<br>XXX, XXXX, XXXXX VOLTS | X.XX    |
| BAR      | Enables the bar graph on the measurement display.   | ON, OFF  | ON      |
| MODE     | Sets the display mode for channel 2; only available when two channels are installed. The units for the sum and ratio modes track the units selected for Channel 2.                                | CH2, CH1+2, CH1/2,<br>OFF                          | CH2     |
| RANGE    | Selects and holds the instrument's measurement range. If repetitive measurements are to be made over a narrow range of levels, selecting the appropriate instrument range may speed measurements. | Auto, 0, 1, 2, 3, 4, 5, 6, 7                       | AUTO    |
| ALARM    | Enables alarm mode; the v or ^ symbol is displayed before the channel mode designator on the measurement display to indicate when the upper or lower threshold limit is exceeded.                 | ON, OFF  | OFF     |
| HI LIMIT | Upper threshold limit for the alarm function.   | -99.99 to 99.99 dBmV                               | 99.99   |
| LOLIMIT  | Lower threshold limit for the alarm function.   | -99.99 to 99.99 dBmV                               | -99.99  |
| Z0       | Characteristic impedance used to calculate power.   | 5 to 2500 Ohms                                     | 50 Ohms |
| PEAK     | Displays sinewave peak instead of RMS. Equal to a factor of 1.414 or + 3dB.   | ON, OFF  | OFF     |
| X100     | Used with 100:1 divider accessory   | ON, OFF  | OFF     |

|   |   |   |   |   |   |   |   |   |  |  |  |  |  |  |  |  |  |  |   |   |
|---|---|---|---|---|---|---|---|---|--|--|--|--|--|--|--|--|--|--|---|---|
| R | T | N |   |   |   |   |   |   |  |  |  |  |  |  |  |  |  |  | ∨ | ^ |
| R | E | C | A | L | L |   |   |   |  |  |  |  |  |  |  |  |  |  |   |   |
| S | A | V | E |   |   |   |   |   |  |  |  |  |  |  |  |  |  |  |   |   |
| P | O | W | E | R | - | U | P |   |  |  |  |  |  |  |  |  |  |  |   |   |
| K | E | Y |   | B | E | E | P |   |  |  |  |  |  |  |  |  |  |  |   |   |
| I | E | E | E |   |   |   |   |   |  |  |  |  |  |  |  |  |  |  |   |   |
| L | I | N | E | F | R | E | Q |   |  |  |  |  |  |  |  |  |  |  |   |   |
| I | N | S | T | R |   | C | A | L |  |  |  |  |  |  |  |  |  |  |   |   |

Figure 3-8. Setup Menu Display, (IEEE Installed)

|   |   |   |   |   |   |   |   |   |  |  |  |  |  |  |  |  |  |  |  |   |   |
|---|---|---|---|---|---|---|---|---|--|--|--|--|--|--|--|--|--|--|--|---|---|
| R | T | N |   |   |   |   |   |   |  |  |  |  |  |  |  |  |  |  |  | ∨ | ^ |
| R | E | C | A | L | L |   |   |   |  |  |  |  |  |  |  |  |  |  |  |   |   |
| S | A | V | E |   |   |   |   |   |  |  |  |  |  |  |  |  |  |  |  |   |   |
| P | O | W | E | R | - | U | P |   |  |  |  |  |  |  |  |  |  |  |  |   |   |
| K | E | Y |   | B | E | E | P |   |  |  |  |  |  |  |  |  |  |  |  |   |   |
| R | S | - | 2 | 3 | 2 |   |   |   |  |  |  |  |  |  |  |  |  |  |  |   |   |
| L | I | N | E | F | R | E | Q |   |  |  |  |  |  |  |  |  |  |  |  |   |   |
| I | N | S | T | R |   | C | A | L |  |  |  |  |  |  |  |  |  |  |  |   |   |

Figure 3-9. Setup Menu Display, (RS-232 Installed)



3-19. Table 3-3 gives a description of the commands, parameters and default settings of the Setup menu.

**TABLE 3-3. SETUP MENU FUNCTIONS <MENU> <SETUP>**

| Function             | Description   | Parameters          | Default |
|----------------------|---|---------------------|---------|
| RTN                  | Returns the instrument to the previous menu.  | n/a                 | n/a     |
| RECALL               | Recalls one of ten user defined instrument configurations or the factory setup.         | Default, 1-10       | Default |
| SAVE                 | Saves the current instrument configuration to one of ten non-volatile memory locations. | 1-10                | 1       |
| POWER-UP             | Instructs the instrument to power-up to the specified configuration.                    | Default, 1, 2, 3, 4 | Default |
| KEYBEEP              | Turns on/off the key beep.  | ON, OFF             | ON      |
| IEEE <sup>1)</sup>   | Brings the instrument to the IEEE menu. (if installed)                                  | see table 3-4       | n/a     |
| RS-232 <sup>1)</sup> | Brings the instrument to the RS-232 menu. (if installed)                                | see table 3-5       | n/a     |
| LINE FREQ            | Select line frequency.  | 50Hz, 60Hz          | 60 Hz   |
| INSTR CAL            | Access instrument calibration settings. For service only.                               | n/a                 | n/a     |

1) Either IEEE-488 or RS-232 interface installed, not both.

**3-20. IEEE Menu.** The IEEE submenu is used to configure the Model 9230 for communications over the GPIB. An example of the menu is shown in Figure 3-10 and the description of the commands, parameters and factory defaults is given in Table 3-4. This menu will appear only if the standard IEEE-488 interface is installed.

**3-21. RS-232 Menu.** The RS-232 menu is used to configure the Model 9230 for serial communications over the RS-232 bus. An example of the submenu is shown in Figure 3-11 and an explanation of the commands, parameters and factory defaults is given in Table 3-5. This menu will appear only if the optional RS-232 interface is installed.

|   |   |   |   |   |   |   |   |   |   |  |  |  |  |  |  |  |  |  |   |   |   |   |
|---|---|---|---|---|---|---|---|---|---|--|--|--|--|--|--|--|--|--|---|---|---|---|
| R | T | N |   |   |   |   |   |   |   |  |  |  |  |  |  |  |  |  | ∨ | ∧ |   |   |
| A | D | D | R | E | S | S |   |   |   |  |  |  |  |  |  |  |  |  | 1 | 5 |   |   |
| E | M | U | L | A | T | I | O | N |   |  |  |  |  |  |  |  |  |  | N | O | N | E |
| E | O | S |   | L | S | T | N |   |   |  |  |  |  |  |  |  |  |  | L | F |   |   |
| E | O | S |   | T | A | L | K | E | R |  |  |  |  |  |  |  |  |  | C | R | L | F |
| E | O | I |   |   |   |   |   |   |   |  |  |  |  |  |  |  |  |  | O | F | F |   |
| S | R | Q |   | M | A | S | K |   |   |  |  |  |  |  |  |  |  |  | 0 |   |   |   |

Figure 3-10. IEEE Menu Display

TABLE 3-4. IEEE MENU FUNCTIONS <MENU> <SETUP> <IEEE>

| Function   | Description   | Parameters   | Default |
|------------|---|--|---------|
| RTN        | Returns the instrument to the previous menu.                        | n/a  | n/a     |
| ADDRESS    | GPIB address assigned to the instrument.                            | 0 to 30  | n/a     |
| EMULATION  |   | n/a  | n/a     |
| EOS LSTN   | End of string indicator for received messages.                      | LF, CR, CRLF, NONE<br>Where:<br>LF = Line Feed<br>CR = Carriage Return<br>CRLF = Carriage Return and Line Feed | LF      |
| EOS TALKER | End of string character sent with transmitted messages.             | LF, CR, CRLF, NONE   | CRLF    |
| EOI        | Enables/disables the end or identify hardware control line.         | ON, OFF  | OFF     |
| SRQ MASK   | Service request interrupt mask. See Table 4-7 for bit descriptions. | 00 to 255<br>Where:<br>255 enables all interrupts  | 0       |

|   |   |   |   |   |   |   |   |   |   |   |   |  |  |  |   |   |   |   |
|---|---|---|---|---|---|---|---|---|---|---|---|--|--|--|---|---|---|---|
| R | T | N |   |   |   | < |   |   |   |   |   |  |  |  |   |   | ∨ | ∧ |
| B | A | U | D |   | R | A | T | E |   |   |   |  |  |  | 9 | 6 | 0 | 0 |
| D | A | T | A |   | B | I | T | S |   |   |   |  |  |  | 8 |   |   |   |
| S | T | O | P | S |   | B | I | T | S |   |   |  |  |  | 1 |   |   |   |
| P | A | R | I | T | Y |   |   |   |   |   |   |  |  |  | N | O | N | E |
| E | O | S |   | L | I | S | T | E | N | E | R |  |  |  | L | F |   |   |
| E | O | S |   | T | A | L | K | E | R |   |   |  |  |  | C | R | L | F |
| S | R | Q |   | M | A | S | K |   |   |   |   |  |  |  | 0 |   |   |   |

Figure 3-11. RS-232 Menu Display

TABLE 3-5. RS-232 MENU FUNCTIONS <MENU> <SETUP> <RS-232>

| Function  | Description   | Parameters  | Default |
|-----------|---|---|---------|
| RTN       | Returns the instrument to the previous menu.                        | n/a   | n/a     |
| BAUDRATE  | Rate at which data is transferred over the bus.                     | 300,1200,2400,9600<br>19200   | 9600    |
| DATA BITS | Number of data bits in a message.                                   | 7,8   | 8       |
| STOPBITS  | Number of stop bits in a message.                                   | 1,2   | 1       |
| PARITY    | Parity bit mode in a message.                                       | ODD,EVEN,NONE   | NONE    |
| EOS       | End of string indicator for received messages.                      | LF,CR,CRLF,NONE   | LF      |
| LISTENER  |   | Where:<br>LF = Line Feed<br>CR = Carriage Return<br>CRLF = Carriage Return<br>& Line Feed |         |
| EOSTALKER | End of string character sent with transmitted messages.             | LF,CR,CRLF,NONE   | CRLF    |
| SRQMASK   | Service request interrupt mask. See Table 4-7 for bit descriptions. | 0 to 255<br>Where:<br>255 enables all interrupts  | 0       |

**3-22. Diagnostics Menu.** The Model 9230 can be directed to perform self-tests from the diagnostics menu. The Diagnostics menu is shown in Figure 3-12 and a description of each command is given in Table 3-6.

**3-23. SENSOR KEY.**

**3-24.** Pressing the <Sensor> key brings the instrument to the Sensor menu and facilitates viewing and editing of the power sensor's parameters. An access code is required to enter the editing mode (refer to Table 3-7). A sample display of the Sensor menu is shown in Figure 3-13.

**3-25.** The instrument is capable of using sensor calibration data from either the sensor data adapters or from any one of four internal tables. The sensor calibration data contained within the sensor data adapter is only accessible to the installed channel. For example, Channel 1 can use the sensor calibration data from any of the internal tables or the sensor data adapter 1. Similarly, Channel 2 can use the sensor calibration data from any of the internal tables or the sensor data adapter 2.

|   |   |   |   |   |   |   |   |  |  |  |  |   |  |  |  |  |  |  |  |
|---|---|---|---|---|---|---|---|--|--|--|--|---|--|--|--|--|--|--|--|
| R | T | N |   |   |   | < |   |  |  |  |  |   |  |  |  |  |  |  |  |
| S | E | L | F | T | E | S | T |  |  |  |  | < |  |  |  |  |  |  |  |
| S | W | I | T | C | H | E | S |  |  |  |  |   |  |  |  |  |  |  |  |
| R | E | C | O | R | D | E | R |  |  |  |  |   |  |  |  |  |  |  |  |

Figure 3-12. Diagnostics Menu Display

TABLE 3-6. DIAGNOSTICS MENU FUNCTIONS <MENU> <DIAGNOSTICS>

| Command  | Description   | Parameters | Default |
|----------|---|------------|---------|
| RTN      | Returns the instrument to the previous menu.  | n/a        | n/a     |
| SELFTEST | Instructs the instrument to perform internal diagnostics and the display test results.  | n/a        | n/a     |
| SWITCHES | Interactive test to verify proper operation of the front panel switches. <MENU> escapes.  | n/a        | n/a     |
| RECORDER | The recorder output DAC is exercised through its full range from 0 to 10 V.D.C. in 1V steps continuously until the <Menu> key is depressed. | n/a        | n/a     |

|   |   |   |   |  |   |   |   |   |   |   |   |   |   |   |   |   |   |   |  |
|---|---|---|---|--|---|---|---|---|---|---|---|---|---|---|---|---|---|---|--|
|   |   |   |   |  |   | C | H | 1 |   |   |   |   |   | C | H | 2 |   |   |  |
| S | E | R | # |  | > | 5 | 0 | 1 | 4 | 0 |   |   |   | 4 | 2 | 9 | 1 | 0 |  |
|   |   |   |   |  |   |   |   |   |   |   |   |   |   |   |   |   |   |   |  |
| E | D | I | T |  | D | A | T | A |   |   | 5 | 0 | 1 | 4 | 0 |   |   |   |  |

Figure 3-13. Sensor Display Menu

Section III  
Operation

**3-26.** Referring to Figure 3-13, the cursor can be positioned to three fields. The two fields below the 'CH1' and 'CH2' indicate the serial number of the sensor whose calibration data is selected for channels 1 and 2 respectively. The instrument uses this data for the linearity and high frequency correction data and automatically applies the correction to the measured value.

**3-27.** To change the current selection for channel 1, use the arrow keys to move to the SER# command line and position the cursor below the 'CH1' field. Press the <Enter> key and use the <Up Arrow> and <Down Arrow> keys to scroll through the parameter list. The parameter list typically consists of serial numbers for each power sensor. Scroll through the list until the desired serial number is displayed and press <Enter> to accept. Move the cursor below the 'CH2' field and follow the same procedure used to change the table for channel 2.

**3-28.** The instrument detects the presence of the sensor data adapter and automatically down-loads the sensor calibration data. This occurs when the power to the unit is first applied or after plugging the sensor data adapter into the instrument. The power sensor and corresponding sensor data adapter have matching serial numbers for maintaining them as a matched pair.

**3-29.** The parameter list will show TBLn (where n = 1, 2, 3, 4) when a serial number has not been entered for the

corresponding internal table. For example, TBL3 will be displayed if the serial number has not been previously entered for internal table 3. In addition, the parameter list will show ADPTn (where n = 1, 2) if a serial number has not been entered for the table contained within the sensor data adapter. For example, ADPT2 is displayed when the serial number has not been previously entered for sensor data adapter 2.

**3-30.** To edit the sensor calibration data, use the <Down Arrow> key to move the cursor to the EDIT DATA function and press <Enter>. Use the <Up Arrow> and <Down Arrow> keys to scroll through the list of serial numbers, adapter numbers and table numbers to locate the desired data for editing. Press <Enter>. A message will request the ACCESS CODE. Enter the ACCESS CODE as described in Table 3-7.

**3-31. Edit Data Menu.** An example of the Edit Data Menu is shown in Figure 3-14. Table 3-8 contains a description of the functions and associated parameters.

**3-32. Linearity Factors.** Eight upscale and downscale linearity factors are assigned to each RF Voltage Probe sensor. These values are unique to each sensor and are the result of a calibration procedure. RF Voltage Probes which are purchased with a Model 9230 or with a Data Adapter will have

**TABLE 3-7. EDIT DATA ACCESS CODE**

The access code to enter the Edit Data menu is as follows:  
Press the front panel switches in the following order:  
<FREQ><AVG><AVG><FREQ><Sensor><Enter>

|   |   |   |   |   |   |   |   |   |  |   |   |   |   |   |   |   |   |   |
|---|---|---|---|---|---|---|---|---|--|---|---|---|---|---|---|---|---|---|
| R | T | N |   |   |   |   |   |   |  |   |   |   |   |   |   |   | ∨ | ^ |
| M | O | D | E | L |   |   |   |   |  | 9 | 5 | 2 | 0 | 0 | 1 |   |   |   |
| S | E | R | I | A | L | # |   |   |  | > | 4 | 2 | 9 | 1 | 0 |   |   |   |
| D | A | T | E |   |   |   |   |   |  | 0 | 7 | / | 2 | 9 | / | 9 | 6 |   |
| U | P | S | C | A | L | E |   |   |  | 0 | : | 4 | 0 | 6 | 5 |   |   |   |
| D | O | W | N | S | C | A | L | E |  | 0 | : | 0 | 0 | 0 | 0 |   |   |   |
| M | I | D | S | C | A | L | E |   |  | 0 | : | 0 | 0 | 0 | 0 |   |   |   |

**Figure 3-14. Edit Data Menu Display**

the linearity factors installed in the adapter at the factory. For probes purchased separately or for older probes undergoing calibration, the data is supplied in printed form. For existing printed linearity data which has only seven sets of factors, enter the data for range 6 into both range 6 and 7 of the 9230. In most cases this will not degrade accuracy.

**3-33.** The linearity factors can be edited by moving the cursor to UPSCALE, DOWNSCALE or MIDSCALE and pressing <Enter>. Press the <Up Arrow> and <Down Arrow> keys to scroll through the 8 values. To edit a value, use the <Right Arrow> and <Left Arrow> keys to position the underline cursor under a digit to be modified and use the <Up Arrow> and <Down Arrow> keys to increment/decrement the digit. Continue with each digit to be modified. If there are no changes to the other seven factors in the group, press <ENTER> to exit the group. Otherwise, move the cursor back to the entry number column on the left and continue editing. When the entire group of 8 factors is correct, press <ENTER>. Continue until all three groups of 8 are correct.

**3-34. Saving the edited values.** Editing the sensor data linearity

and other values in the menu does not automatically write the changes into the data adapter or tables. When exiting the menu either by use of the RTN function or by pressing another top level key, a confirmation message will appear, "CONFIRM SAVE" NO/YES. The default answer is NO. To cause the edited data to be written into the adapter or table, the "YES" answer must be selected and <ENTER> pressed. Any other action will cause the edit to be discarded and the data in the adapter or table will remain unchanged.

**3-35. FREQ Key.** The FREQ is not currently used for RF Voltmeter operation. The parameters which appear in the menu are not active.

**3-36. AVG Key.**

**3-37.** The averaging time may be adjusted to optimize measurement speed and display stability. Averaging time, in seconds, can be adjusted in 0.05 increments to a maximum of 20.00 seconds.

**3-38.** To adjust the averaging time, press the <AVG> key and the instrument will display the screen as shown in

**TABLE 3-8. EDIT DATA MENU FUNCTIONS**

<SENSOR> <V> <ENTER> [SELECT S/N or TBL n] <ENTER> [ACCESS CODE]

| Function  | Description                                 | Parameters  | Default  |
|-----------|---|---|----------|
| RTN       | Returns the instrument to the previous menu | n/a   | n/a      |
| MODEL     | Power sensor model number                   | 0 to 99999  | 0        |
| SER#      | Power sensor serial number                  | 0 to 99999  | 0        |
| DATE      | Calibration date                            | MM/DD/YY<br>Where:<br>MM = 01 to 12<br>DD = 01 to 31<br>YY = 00 to 99 | 01/01/01 |
| UPSCALE   | Upscale linearity factors                   | Range: Factor<br>[0 to 7]: [0 to 9999]                                | 5000     |
| DOWNSCALE | Downscale linearity factors                 | Range : Factor<br>[0 to 7]: [-999 to 999]                             | 0        |
| MIDSCALE  | Midscale linearity factors                  | Range: Factor<br>[0 to 7]: [-999 to 999]                              | 0        |

Section III  
Operation

Figure 3-15. Position the cursor under the desired channel heading and press the <Enter> key. Use the arrow keys to set the desired value and then press <Enter> to accept. Entering 00.00 selects the auto filtering Mode. This menu can be accessed to show the filter setting in the auto mode.

**3-39. ZERO Key.** Press the <ZERO> key to select CH1 or CH2 for zeroing. Zeroing must always be performed when the instrument is turned ON, preferably after a warm-up period of 5 to 15 minutes and when a sensor is changed. Periodic zeroing is required when low level voltages are measured. For critical applications perform a zero before each measurement. For measurements above 30 mV, intervals of several hours are practical provided the thermal environment is stable.

The instrument calculates and stores zero corrections for each hardware range and applies the corrections to subsequent measurements. The zero corrections are lost when the power is turned OFF.

The RF Probe sensor must be disconnected from all signal sources while the zeroing procedure takes place. In noisy RF environments, place a 50 Ohm termination on the probe during zeroing.

**3-40. REF LEVEL Key.**

**3-41.** Press the <REF Level> key to enter a value or to use

the current channel measurement for the reference level. The measurement units will automatically change to dBr for subsequent measurements. An example of the instrument's display is shown in Figure 3-17.

**3-42.** To set a reference level, depress the <REF Level> key to display the REFERENCE LEVEL sub-menu. Move the cursor to the reference value for the appropriate channel. (Channel 1 is default.) Depress the <Enter> key to initiate the editing process. Use the arrow keys to edit the reference value in dBm. Once the desired value has been selected, depress the <Enter> key to leave the editing function. To use this value as the reference, depress the <Down Arrow> key to MODE, depress the <Enter> key for mode selection and using the <Up> or <Down Arrow> keys, select SET. Depressing the <Enter> key will place the appropriate channel to the "dBr" mode of operation using the set value as the reference.

The instrument can also load the current measured value as the reference level. To do this, depress the <REF Level> key to display the REFERENCE LEVEL sub-menu. Navigate the cursor using the arrow keys to the MODE selection of the desired channel. Depress the <Enter> key for mode selection and using the <Up> or <Down Arrow> keys, select LOAD. Depressing the <Enter> key will place the appropriate channel to the dBr mode of operation using the measured value as the reference level.

To turn off relative measurements, select OFF as the MODE.

To turn off relative measurements, select OFF as the MODE.

|   |   |   |   |   |   |   |   |   |   |   |  |   |   |   |   |   |  |
|---|---|---|---|---|---|---|---|---|---|---|--|---|---|---|---|---|--|
| T | I | M | E |   |   |   |   |   |   |   |  |   |   |   |   |   |  |
|   |   |   |   |   | C | H | 1 |   |   |   |  | C | H | 2 |   |   |  |
| S | E | C |   | > | 1 | 0 | . | 5 | 0 |   |  | 0 | 0 | . | 8 | 0 |  |
| S | A | M | P | S |   |   | 2 |   | 1 | 0 |  |   |   |   | 1 | 6 |  |

Figure 3-15. Averaging Time Display

|   |   |   |   |  |  |  |  |  |  |  |  |   |   |   |  |   |   |   |  |  |
|---|---|---|---|--|--|--|--|--|--|--|--|---|---|---|--|---|---|---|--|--|
|   |   |   |   |  |  |  |  |  |  |  |  | C | H | 1 |  | C | H | 2 |  |  |
|   |   |   |   |  |  |  |  |  |  |  |  |   |   |   |  |   |   |   |  |  |
| Z | E | R | O |  |  |  |  |  |  |  |  |   | > |   |  |   |   |   |  |  |
|   |   |   |   |  |  |  |  |  |  |  |  |   |   |   |  |   |   |   |  |  |

Figure 3-16. Zero and Calibration Display

|   |   |   |   |   |   |   |   |   |   |   |   |   |   |   |   |   |   |   |
|---|---|---|---|---|---|---|---|---|---|---|---|---|---|---|---|---|---|---|
| R | E | F | E | R | E | N | C | E |   | L | E | V | E | L |   |   |   |   |
|   |   |   |   |   | C | H | 1 |   |   |   |   |   | C | H | 2 |   |   |   |
| d | B | m |   |   | + | 0 | 0 | . | 0 | 0 |   |   | + | 2 | 5 | . | 0 | 0 |
| M | O | D | E |   | L | O | A | D |   |   |   |   | S | E | T |   |   |   |

Figure 3-17. Reference Level Display

TABLE 3-9. REFERENCE LEVEL MENU FUNCTIONS

| Function | Description  | Parameters         | Default |
|----------|--|--------------------|---------|
| dB       | Reference level value in Preset mode.  | -99.99 to 99.99 dB | 0       |
| MODE     | Reference level mode. "LOAD" makes the current channel measurement as the reference level. The Set mode is used to select the entered reference level. The Off mode disables the reference level adjustment. | LOAD, SET, OFF     | OFF     |



## SECTION IV APPLICATION NOTES

### 4-1. ZEROING THE INSTRUMENT.

For greatest accuracy, especially on the more sensitive ranges, the instrument must be zeroed. To eliminate the need for tedious and often inaccurate manual zeroing, the instrument incorporates an automatic zeroing capability. When automatic zeroing is initiated, the microprocessor reads, averages and stores zero corrections for each measurement range of the instrument and applies the proper zero correction for the range in use for all subsequent measurements. Zero corrections are most important on the more sensitive ranges of the instrument. During instrument warm-up periods and during use in environments with varying ambient temperatures, the instrument should be zeroed frequently if measurements are being made on the lower ranges. To zero the instrument, proceed as follows:



Never press the ZERO key with a signal applied to the probe. To do so will result in erroneous zero corrections and inaccurate subsequent measurements. If the input exceeds normal zero offsets, an error message will be displayed when automatic zeroing is initiated; remove the input signal and rezero the instrument.

**1. Remove All Input Signal to the Probe.** This can be done by unscrewing the probe tip until the tip just breaks contact with the internal connection, leaving the metal shell engaged with the probe body threads. Alternatively, the probe tip can be removed and a Model 952002 50  $\Omega$  adapter connected in its place.

**2. Press the ZERO key.** The automatic zeroing cycle takes approximately 9 seconds; the microprocessor computes and stores zero corrections during this period. When zeroing is complete, the instrument display typically shows -99.99 in all dB modes, indicating input underrange. In the mV mode, the underrange indication does not appear; the instrument display shows the "zero condition". This is composed of residual noise and offsets and, ideally, should show + and - excursions of similar amplitude less than 100  $\mu$ V.

**4-2. MAKING MEASUREMENTS.** Once the instrument has been programmed and zeroed, it is ready for voltage or dB level measurements. Merely connect the probe to the source whose voltage or dB level is to be measured; the measured level will be displayed directly.

### 4-3. OVERLOAD LIMITS.

1. The Model 952001B RF Probe supplied with the

instrument is overload protected to 10 volts AC and 200 volts DC. Exceeding these limits may result in permanent damage.

2. The Model 952002 50  $\Omega$  BNC Adapter supplied with the instrument should not be subjected to continuous overload of more than 10 volts (DC + RMS AC) in order to avoid excessive heating of the terminating resistor.

3. Where voltages above the specified overload limits are likely to be encountered, use the Model 952005 100:1 Voltage Divider. Maximum rating of the voltage divider is 1000 volts (DC + peak AC).

**4-4.** The terminated Model 952009 RF Probe should not be subjected to continuous overload of more than 4 volts (DC + rms AC) in order to avoid excessive heating of the terminating resistor. Exceeding these limits may result in permanent damage.

### 4-5. CONNECTION RECOMMENDATIONS.

1. The Model 952001B probe is equipped with a detachable tip and ground lead. For measurement of signals below approximately 100 MHz, this tip provides a convenient means for making both signal and ground connections.

2. For frequencies above 100 MHz, the probe tip should not be used because the series impedances of the connection will affect the voltage level at the probe and cause an error in measurement. For high impedance voltage measurements, connection should be made directly to the center contact of the RF probe, with the ground connection kept as short as possible. For matched impedance measurements, one of the various terminated adapters, tee adapter or Model 952009 Probe should be used. Refer to Figure 4-1.

**4-6. LOW LEVEL MEASUREMENTS.** The instrument will provide reliable, repeatable measurements of signal levels as low as 200 microvolts. Useful indications extend down to 50  $\mu$  V. Zeroing of the instrument is essential when using the lower ranges in order to achieve the specified accuracy. Zeroing is also strongly recommended for all ranges up to 30 millivolts. Refer to paragraph 4-1 for the zeroing procedure.

### 4-7. TEMPERATURE EFFECTS.

1. The accuracy specifications for the instrument apply over a temperature range of 0°C to 50°C. Outside these limits, operation of the instrument is possible, but appreciable inaccuracies can be expected; however, no permanent change in probe characteristics will result from any reasonably high or low temperature exposure.

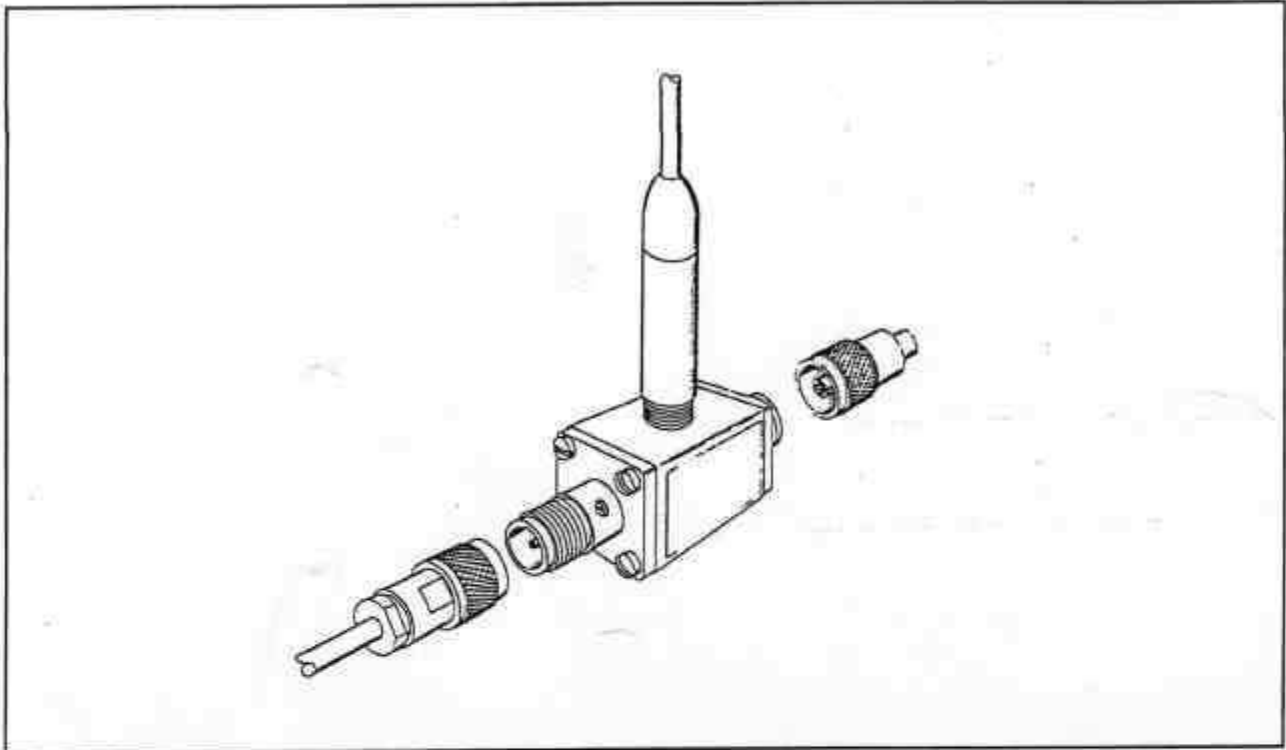

Figure 4-1. Attachment of Model 952003 to (Type N) Tee Adapter to Model 952001B Probe and Model 952014 50 Ohm Termination

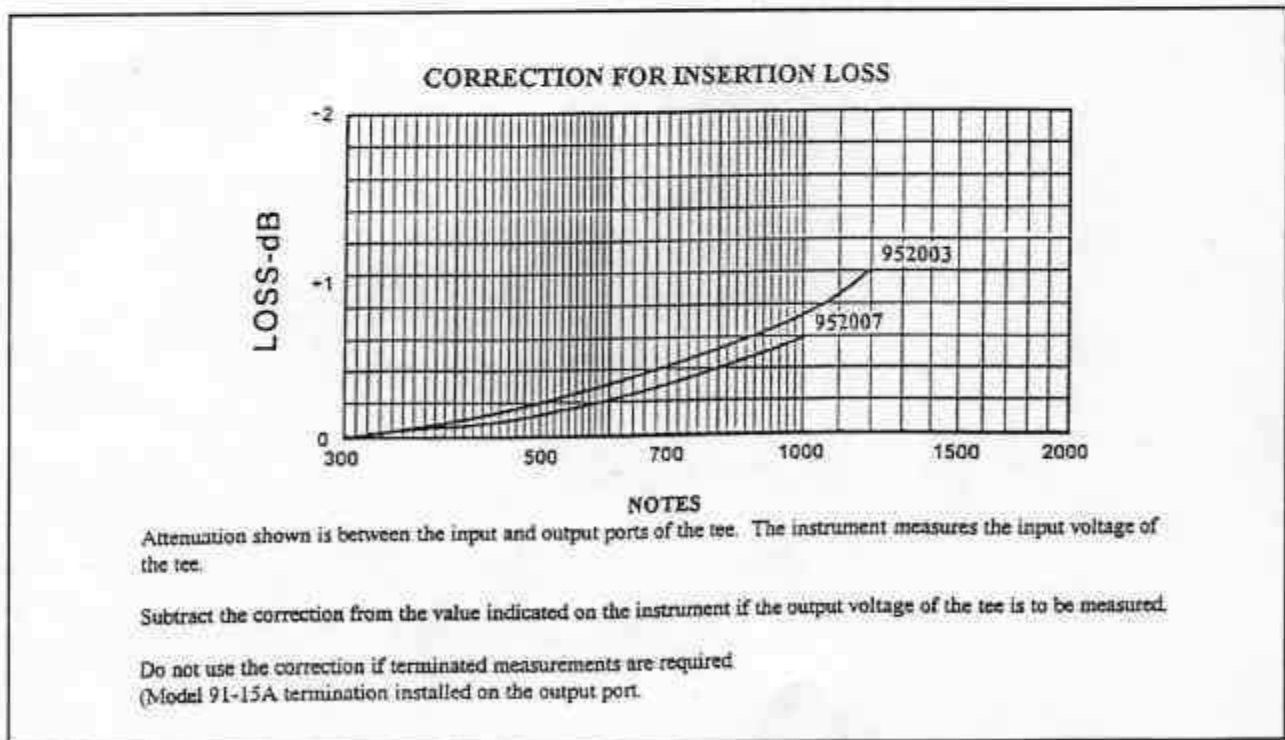

Figure 4-2. Correction Curves for Model 952003 and 952007 (Type N) Tee Adapters

2. It should be noted that inaccuracies of measurement resulting from temperature effects may occur when measuring with the probe in the vicinity of heat sources such as resistors, heat sinks and so forth.

3. When making low level measurements (below approximately 2 millivolts), it is important to make sure that the probe has attained a uniform temperature throughout its body. A temperature gradient between the inside and outside of the probe can generate a small thermal voltage that may add to the DC output of the detector diodes.

**4-8. HUM, NOISE AND SPURIOUS PICKUP.** When measuring low level signals, precautions should always be taken to avoid the possibility of measurement errors resulting from hum, noise or stray RF pickup. Although all low frequency hum and noise are attenuated at the input, unwanted high level signals could still possibly cause error. In some cases it may be necessary to provide extra shielding around the probe connection to reduce stray pickup. Some typical sources of spurious radiation are dielectric heating units, diathermic machines and transmitters.

**4-9. RECORDER OUTPUT.** The DC output provided at the rear panel RECORDER connector may be used to drive an XY recorder for swept measurements, or a strip chart recorder for monitoring applications. Refer to Section 2, paragraph 2-7.

**4-10. CORRECTION CURVE for MODEL 952003 50 Ohm Type N Tee Adapter.** When using the optional Model 952003 Tee Adapter, the input voltage to the adapter is indicated directly on the instrument. To obtain the correct output voltage from the adapter, subtract the correction shown in Figure 4-2 from the input voltage, in dB, indicated on the instrument. Corrections are not required if the Model 952003 is terminated with 50 Ω .

**4-11. CORRECTION CURVE for MODEL 952007 75 Ohm Type N Tee Adapter.** When using the optional Model 952007 Tee Adapter, the input voltage to the adapter is indicated directly on the instrument. To obtain the correct output voltage from the adapter, subtract the correction shown in Figure 4-2 from the input voltage, in dB, indicated on the instrument. Corrections are not required if the Model 952007 is terminated with 75Ω .

**4-12. RF Power Measurements.** The Z<sub>0</sub> function in the CHANNELS sub-menu enables the user to set a characteristic impedance to be used for power calculations. The default value is 50 ohms; however, values from 5 to 2500 ohms may be used. This value is used only in association with the dBm and dBW units. The power level is calculated using the expression:

$$P=V^2/Z_0 \text{ where } V \text{ is in volts}$$

Z<sub>0</sub> is in ohms

P is in watts

For dBm units, the result is the ratio in decibels of the calculated power to 1 milliwatt (0 dBm = 1 milliwatt). For dBW units, the result is the ratio in decibels of the calculated power to 1 watt (0 dBW = 1 watt). This capability is useful for determining the power dissipated in a non-standard load impedance or in a load which is not part of a coaxial transmission line. The accuracy of this method depends upon the ability to measure the effective voltage across the load. The RF Probe enables the user to reach components mounted on circuit boards.

#### 4-13. REMOTE (GPIB) OPERATION.

**4-14. Introduction.** If the Model 9230 is equipped with the IEEE-488 interface, the instrument can be operated remotely through an IEEE-488 interface. The IEEE-488 is a hardware standard which describes the communication and handshaking across the 8-bit parallel bus between a bus controller and up to 15 instruments.

**4-15.** The Model 9230 IEEE-488 capabilities are as follows:

|     |                    |  |
|-----|--------------------|--|
| C0  | NO CONTROLLER      | Capability                                   |
| SH1 | SOURCE HANDSHAKE   | Complete capability                          |
| AH1 | ACCEPTOR HANDSHAKE | Complete capability                          |
| RL1 | REMOTE LOCAL       | Complete capability                          |
| DC1 | DEVICE CLEAR       | Complete capability                          |
| DT1 | DEVICE TRIGGER     | Complete capability                          |
| RL1 | REMOTE LOCAL       | Complete capability                          |
| DC1 | DEVICE CLEAR       | Complete capability                          |
| DT1 | DEVICE TRIGGER     | Complete capability                          |
| PP0 | PARALLEL POLL      | No capability                                |
| TE0 | EXTENDED TALKER    | No capability                                |
| T6  | BASIC TALKER       | Complete capability except for talker only   |
| LE0 | EXTENDED LISTENER  | No capability                                |
| L4  | BASIC LISTENER     | Complete capability except for listener only |
| DMA |                    | Not supported                                |

**4-16. Local Operation.** This is the front panel operation of the instrument. The instrument initializes to the local mode on bus power on, and the remote mode becomes active only when the instrument is remote addressed by the bus controller. Once in the remote mode, the instrument can be returned to the local mode in any of three ways: by a GTL (go to local) command from the bus controller, by turning off power to the instrument, or by pressing the front panel <Menu> key. The third method can be disabled by a local lockout (LLO) command issued by the bus controller.

**4-17. Remote Operation.** In the remote mode, all front panel key closures are ignored except for the <Menu> key (which may also be disabled by a LLO command from the bus controller). When the instrument is in the remote mode, the front panel REM annunciator is activated.

**4-18. Bus Address.** The IEEE-488 listen/talk address (MLTA) of the instrument can only be altered from the MENU-Setup-IEEE menu. Refer to paragraph 3-20.

**4-19. Terminating Characters.** To inform the instrument that a message has been completed, the bus controller must end all messages with a terminating character or EOI control signal. The Model 9230 can be programmed for several combinations of terminating characters as required by the controller employed. Selection of terminating characters is accomplished via the MENU-Setup-IEEE menu. There the instrument can be programmed for individual end of string characters in both listener and talker modes as well as independently enabling the end or initiate control signal.

**4-20. Listen Operation.** The instrument may be addressed as a listener without regard for remote or local mode. When the listener state is set by the bus controller, the instrument will receive bytes over the bus and place them in its input buffer. For listen operation, the input buffer is 150 characters long. Only one message can be entered into the input buffer at a time. A second message cannot be sent until the instrument has processed the previous message.

**4-21. Talk Operation.** When the instrument is requested to talk, the instrument response will depend on how it has been set up. The setup is either through talk modes or talk array commands. Talk modes are associated with making measurements; talk array commands are associated with the downloading of calibration data and instrument states. Refer to paragraph 4-30 for setup of the talk mode.

**4-22.** Only one instrument at a time can be addressed to talk, but many instruments can be addressed to listen simultaneously. When the Model 9230 is in the talk mode, the front panel TLK annunciator is illuminated. The format for each talk message is different and is explained in the paragraphs that follow.

**4-23. IEEE-488 Command Support.** The Model 9230 supports the following standard IEEE-488 commands:

a. Interface Clear Command. The interface clear (IFC) command forces all devices on the bus to clear their interfaces, and the bus to an initialized state, clearing the error condition. This command can only be issued by the bus controller in charge. The Model 9230 responds by clearing the interface.

b. Device Clear. For this instrument, the device clear (DCL) command operates the same way as the IFC command described above.

c. Group Execute Trigger. The group execute trigger (GET) command allows the bus controller to issue a trigger to all instruments on the bus simultaneously. The Model 9230 will save the current reading at the time of the GET command and return it at the time of the next talk message mode. This is in essence a bus latch. The instrument must be set to one of its trigger modes. See paragraph 4-56.

d. SRQ. The service request (SRQ) allows an instrument to inform the bus controller that some special event has occurred. The instrument then expects the bus controller to perform a serial poll to determine what event has occurred. Events that generate service requests include instrument error, measurement error, measurement is ready, and zeroing or calibration is completed. When the instrument SRQ is active, the front panel SRQ annunciator is illuminated.

e. Serial Poll. The serial poll (SP) command on the bus allows the bus controller to check the SRQ status byte of each instrument to determine which instrument is requesting service. The byte returned by the Model 9230 is composed of multiple bits that represent different status and error conditions. These conditions are individually maskable, as shown in Table 4-7.

f. Parallel Poll. The parallel poll (PP) command is not supported.

**4-24. Number Formatting.** Number formatting is shown for each of the commands in the paragraphs that follow, but general rules are as follows:

a. Fixed or floating formats are accepted.

b. The optional + or - may precede the mantissa and/or the exponent.

c. An optional decimal point may appear at any position within the mantissa. A decimal point in the exponent is ignored.

d. The optional "E" for exponent may be upper or lower case.

e. All ASCII characters below and including ";" (3Bh) are considered command delimiters. The ASCII characters " " (20h), ",", ";" (3Bh), and ":" (3Ah) are considered numeric delimiters.

**4-25. String Format.** String formatting is as follows:

- a. The programming sequence is in natural order, that is, a function mnemonic is sent first, followed by the argument value (parameter), if applicable.
- b. The data strings sent to the instrument are not case sensitive. This means lower case and upper case are the same.
- c. Spurious numbers occurring in the listen string are ignored.
- d. All array modes have formatted data or ASCII strings. See paragraph 4-43.

**4-26. Listen Parameter Commands.** Listen parameter commands are listed in Table 4-1. These are commands, received by the instrument, that expect one numerical value to follow for setting a particular operating condition. Except as noted in the table, these commands correspond to specific front panel commands. Key commands correspond to single

keystrokes; non-key commands are submodes or menu types of data entry.

**4-27.** The numeric value (parameter) can be sent in the next listen string if the listen parameter command was the last value of the previous string. If, for any reason, a command is sent without a parameter following the command, the CL command can be used to clear the active command, or a new command can be used. The parameter number listed in Table 4-1 is the number returned when the talk parameter mode (talk mode 6) is exercised.

**4-28. Listen Action Commands.** Listen action commands are listed in Table 4-2. These commands initiate an action without any parameters being sent.

**4-29. Listen Array Commands.** Listen array commands listed in Table 4-3 transfer arrays of data (more than one parameter) to the instrument. Sensor data and DC calibra-

**TABLE 4-1. LISTEN PARAMETER COMMANDS**

| Mnemonic | Function and Limits  | Description  | Parameter No.   |
|----------|--|--|-----------------|
| CH#      | Channel select<br># 1, 2   | Sets channel   | 12,N            |
| FL#      | Filter time select<br># 0 to 20.00 in 0.05 steps   | Corresponds to AVG-Sec data entry<br>(AUTO FILTER MODE when set to 0)<br>(see FA command)  | 3,N             |
| LH#      | High limit select<br># -99.99 to 99.99 in 0.01 steps<br>(or 0 to 99999 in Watts mode)  | Corresponds to Menu -Channels-Hi Lmt data entry  | 14,N            |
| LL#      | Low limit select<br># -99.99 to 99.99 to 0.01 steps<br>(or 0 to 99999 in Watts mode)   | Corresponds to Menu-Channels-Lo Lmt data entry   | 15, N           |
| LM#      | Alarm select<br># 0 disable<br># 1 enable  | Corresponds to Menu-Channels-Alarm command   | 17, N           |
| RS#      | Range select<br># 0 to 7   | Corresponds to Menu-Channels-Range selection   | 5, N (-1 = RA)* |
| SM#      | SRQ Mask<br># 0 - 255  | Corresponds to the Menu-Setup-IEEE-SRQ Mask data entry   | 11, N           |
| SR#      | Set dBr reference<br># -99.99 to 99.99 in 0.01 steps   | Corresponds to REF Level-dB data entry with Mode=Set   | 6,N             |
| Z0       | #5 - 2500 ohms   | Impedance for power calculation  | 19,N            |
| SS#      | Sensor data source<br># 1 - 6<br>Where:<br># 1 - 4 are internal tables<br># 5 is the sensor data adapter for channel 1<br># 6 is the sensor data adapter for channel 2 | Corresponds to Sensor-Ser# selection. Use CH# to select channel before using SS#. (Selection of an invalid table may cause malfunction.) | 1,N             |
| TM#      | Talk Mode<br># 0 to 6  | Sets talk mode for IEEE-488 bus operation.   | 8,N             |

tion data are typical data. The data array is formatted as in paragraph 4-93. The actual amount of data depends on the specific command being used. Listen array commands are only operable over the bus, and have no application from the front panel.

**4-30. Talk Modes.** When the Model 9230 is requested to talk, it responds according to how it has been set up. The talk setup is either through talk array commands or talk modes. Talk modes are associated with making measurements; talk array commands are associated with downloading of calibration data and instrument states. The talk modes are described in the following paragraphs.

**4-31.** The Model 9230 supports eight talk modes of operation, as listed in Table 4-5. Once the talk mode has been set, the bus controller need only tell the Model 9230 to talk and it will respond according to the talk mode.

**4-32.** Talk modes 0 through 6 can be set directly by use of the talk mode (TM) command. For these modes, the instrument will remain in the selected mode until the talk mode is changed or until a talk array command is received. Talk mode 7 is a temporary talk mode that is automatically enabled in response to a talk array command. This mode cannot be set by the bus controller directly. This temporary talk mode is disabled when the talk array operation is complete.

**4-33.** The default condition for the talk mode is 0. The talk modes are described individually in paragraphs 4-77 through 4-86.

**4-34. Talk Mode 0 (Talk Measurement Floating Point).** The talk mode 0 format is as follows:

#1,#2

where:

#1 is the error flag (1 = error, data invalid).

#2 is the measurement in floating point notation in the units selected (dBV, dBmV, dBW, dBm or dBr). In volts mode, the unit is fixed at mV.

Examples:

0,1.5E3 - No error, voltage is 1.5 volts.

1,0 - Under range error at <100µV.

0,98.9 - No error, power is 98.9 millivolts.

**4-35. Talk Mode 1 (Talk Measurement with Units).** The format for talk mode 1 is as follows:

#1,\$1

where:

#1 is the error flag (1 = error).

\$1 is the measurement. The format is fixed point followed immediately by a string that indicates the unit of measurement. Possible units are mV, dBV, dBmV, dBW, %, dBm. If needed, the string can be parsed externally into a number and a three character message.

Examples:

0,0.00dBV - No error at 0.00 dBV

1,0dBV - Under range error at dBV

0,98.9mV - No error at 98.9 millivolts

**4-36. Talk Mode 2 (Talk Error).** The talk mode 2 format is as follows:

#1,#2,#3

where:

#1 is the instrument error number. A 0 will always be reported in this position.

#2 is the measurement error, from 0 to 99. A 0 indicates no error. Refer to Table 4-6 for error messages.

#3 is the channel reporting errors. A 1 is reported for channel 1 and a 2 is reported for channel 2.

Execution of this talk mode automatically clears the measurement error after it has been reported. If more than one error occurs, the instrument will indicate the first one that occurred.

Examples:

0,0,1 - No error is reported for channel 1

0,3,2 - Measurement level is underrange for channel 2

**4-37. Talk Mode 3 (Talk Both Channels).** The talk mode 3 format is as follows:

#1, #2, #3, #4

where:

#1 is the error flag for channel 1

(1 = error, data invalid)

#2 is the measurement in floating point notation in the units selected.

#3 is the error flag for channel 2 (1 = error, data invalid)

#4 is the measurement in floating point notation in the units selected.

**TABLE 4-2. LISTEN ACTION COMMANDS**

| <b>Mnem-<br/>onic</b> | <b>Function</b>           | <b>Description</b>   | <b>Menum-<br/>onic</b> | <b>Function</b>     | <b>Description</b>                                  |
|-----------------------|---------------------------|--|------------------------|---------------------|---|
| CL                    | Clear                     | Clears error number and error  | MS                     | Measure Settled     | Sets settled measurement mode                       |
| DB                    | dBmselect                 | Corresponds to Menu--Channel-Units-dBm selection   | TF                     | Trigger Filtered    | Selects filtered trigger mode                       |
| DF                    | Display off               | Turns off instrument display   | TFD                    | Trigger Fast Dual   | Selects fast dual channels trigger mode             |
| DN                    | Display on                | Turns on instrument display  | TFS                    | Trigger Fast Single | Selects fast single channel (CH1 only) trigger mode |
| DR                    | dBr select                | Corresponds to REF-Level-Mode equal to SET using the previous reference level                      | TN                     | Trigger Normal      | Selects normal trigger mode                         |
| FA                    | Auto filter               | Sets instrument to auto filter   | TR                     | Bus trigger         | Bus trigger command                                 |
| LR                    | Load Reference            | Loads the current measurement as the reference level. Corresponds to REF Level-Mode equal to LOAD. | TS                     | Trigger Settled     | Selects settled trigger mode                        |
| MF                    | Measure Filtered          | Sets filtered measurement Mode   | ZR                     | Instrument zero     | Corresponds to Zero/CAL-ZERO selection              |
| MFD                   | Measure Fast Dual         | Sets fast dual channels measurement mode   | ?ID                    | Talk instrument ID  | Calls up instrument identification                  |
| MFS                   | Measure Fast Single       | Sets fast single channel (CH1 only) measurement mode   | *IDN?                  | Talk instrument ID  | Calls up instrument identification                  |
| MN                    | Measure Normal (free run) | Sets normal free run measurement mode  |                        |                     |   |

**4-38. Talk Mode 4 (Talk with Channel Status).** The format for talk mode 4 is as follows:

#1,#2,#3,#4,#5,#6,#7

where:

#1 is always 1 in the 9230

#2 is always 1 in the 9230

#3 is the measurement units that the channel is set;

2 - mV

3 - dBr, %

4 - -dBmV

5 - -dBV, dBm

6 - -dBW

#4 indicates the trigger mode of operation;

0 Measure Normal (also known as free-run)

1 Measure Filtered

2 Measure Settled

3 Trigger Normal

4 Trigger Filtered

5 Trigger Settled

6 Reserved

7 Measured Fast Single

8 Measured Fast Dual

9 Reserved

10 Trigger Fast Single

11 Trigger Fast Dual

#5 is always 0 in the 9230

#6 is always 0 in the 9230

#7 is the software version number.

**4-39. Talk Mode 5 (Talk Instrument Status).** Not used for 9230.

#1,#2,#3,#4

Always returns 0,1,00

**4-40. Talk Mode 6 (Talk Parameter).** The format for talk mode 6 is as follows:

#1,#2

where:

#1 is the active parameter number (0 = no parameter selected).

#2 is the active parameter value, for example

“frequency”. The units are defaulted.

**4-41.** This command returns two numbers which describe the current “opened” or selected parameter in the instrument and its value. For example, the frequency to which the instrument is set can be read over the bus. To read a parameter, it must be “opened” first as described in paragraph 4-85. A parameter in the Model 9230 is defined as a front panel or bus command that allows or requires a numerical value to be entered into it. The parameters and parameter numbers are listed in Table 4-1. The data sent over the bus is the same as the data that would appear on the instrument’s displays when the parameter is selected.

**4-42.** To use this talk mode, the instrument is first placed in talk mode 6 and a parameter is then opened (made active) by sending the bus command. No numeric value should follow and the clear command should not be used. Then, while the parameter is active, a talk command is issued to the instrument and the data for that parameter is sent out on the bus. A parameter can be deactivated by simply entering a number or sending another command.

Examples:

0,0 No parameter is active and the second value should be ignored

14,-3.00 The High Limit Value is currently set to -3.00 dB.

5,1 Range 1 is set.

**4-43. Talk Mode 7 (Talk Array).** Each of the different talk array commands has a different format. (Refer to the applicable section of paragraph 4-75.) This talk mode is not directly settable by the bus controller; it is set automatically by execution of one of the talk array commands. Talk mode 7 builds a data string in the talk buffer for a one time transmission. It is used to send an array of numerical data or a string of character data, such as sensor and/or calibration data. Once executed, this mode is automatically cleared to its previously selected value or default condition.

**4-44. Talk Mode (TM) Command.** The talk mode command is used to change to a selected talk mode. The range of data for this command is from 0 to 6. Talk mode 7 can only be set indirectly by execution of a talk array command. The talk mode command is classified as a listen parameter command.

Example:

TM1 - Set talk mode 1 which is talk measurement with units.

**4-45. VSO Command.** The VSO command is used to request sensor data from the Model 9230. The data is read from the active sensor data adapter or table and formatted



as described below. Before using the VSO command, select the channel using the CH command. If the sensor data source desired is not selected, select it using the SS command. The data string returned is made up of the

Model\_number, Serial\_number,  
U0,...,U7,D0,...,D7,M0,...,M7

Sensor Model number in the form 95XXXX where XXXX is 4 digits which complete the RF Probe model number, e.g. 952001.

Sensor Serial number between 0 and 99999, e.g. 309321.

U0-U7 Upscale calibration factors, 1000 to 9000.

D0-D7 Downscale calibration factors, -999 to +999.

M0-M7 Midscale calibration factors, -999 to 999.

**4-46. VSI Command.** The VSI command is used to send sensor data to the Model 9230. If valid data is received it will be loaded into the active sensor data adapter or data table. Before using the VSO command, select the channel using the CH command. If the sensor data destination desired is not selected, select it using the SS command. The data string format is identical to that for the VSO command.

VSI Model\_number,Serial\_number,U0,...,U7,D0,...,D7,  
M0,...M7

Example:

VSI952001,23456,5011,5026,4998,5001,5030,5066,5500,6000,0,0,  
-11,21,19,-1,0,0,44,21,-21,5,0,0,9,-8

The model number must be valid and the number of entries must be correct or the data will be discarded. Always use the VSO command to read back the data and verify successful operation.

**4-47. DF Command.** This command blanks the front panel display for secure ATE applications and speeds up operations by reducing the number of tasks that have to be performed by the Model 9230. When the display is turned off, the display hardware is still functional, but it is not updated for certain types of information.

**4-48. DN Command.** This command enables the front panel display, complementing the DF command.

**4-49. SM (SRQ Mask) Command.** This command is used to set the SRQ mask which selectively enables service requests generated by the Model 9230. The range of numeric entry is from 0 to 255. The SRQ mask is logically ANDed with the SRQ sources to determine if an SRQ should be generated. The SRQ bit map is shown in Table 4-7. For more information on SRQ and the related serial poll, refer to paragraph 4-23.

Examples:

SM 0 - Disable all service requests

SM 2 - Enable SRQ only on measurement errors

SM 8 - Enable service request only when a zeroing operation is complete

#### 4-50. MEASURED AND TRIGGERED OPERATION AND SETTLED READING.

**4-51. General.** Five measurement modes and five triggered modes are available over the bus. They are:

- a. Measure Normal (also known as free-run)
- b. Measure Filtered
- c. Measure Settled
- d. Measure Fast Single Channel
- e. Measure Fast Dual Channels
- f. Trigger Normal
- g. Trigger Filtered
- h. Trigger Settled
- i. Trigger Fast Single Channel
- j. Trigger Fast Dual Channels

The instrument must be in remote bus operation to invoke these modes of operation. When in local operation, only measure normal is available. The five measurement modes are each self triggering (free running) while the triggered modes require a bus trigger command. The operation of each mode is modified by filter selection and range selection. See paragraphs 4-16 and 4-18. The modes are described below.

**4-52. Measure Normal (MN).** This is the mode to which the instrument initializes at power up when the local

TABLE 4-5. TALK MODES

| Talk Mode | Description                     |
|-----------|---------------------------------|
| 0         | Talk measurement floating point |
| 1         | Talk measurement with units     |
| 2         | Talk error                      |
| 3         | Talk both channels              |
| 4         | Talk channel status             |
| 5         | Talk instrument status          |
| 6         | Talk parameter                  |
| 7         | Talk array (Indirect only)      |

command is issued in bus operation or when returning from a calibration mode.

**4-53. Measure Filtered (MF).** In this mode, the front panel display is self triggered and continuously updated. In response to a step change in power of approximately 0.02 dB or an internal range change, the front panel displays the " - - -" (dashes) message until the digital filter time constant has elapsed. This mode guarantees that the reading is filtered by holding off the display of partially filtered readings.

**4-54. Measure Settled (MS).** In the MS mode, the front panel display is self-triggered and continuously updated. In response to a step change in power or an internal range change, the front panel displays the " \_ \_ \_" (dashes) message until the settled condition occurs. The minimum time for a settled reading is twice the selected filter time constant. The maximum time is unlimited, because the settled condition may never occur for noisy signals or constantly varying signals. This mode should not be used in a data acquisition system because the unsettled condition may hold off the GPIB indefinitely.

**4-55. Measure Fast Single (MFS).** The measure fast single channel mode of operation provides the instrument's fastest measurement response when addressed to talk over the IEEE bus. Measurements at a rate of 240 readings per second can be obtained (see Figure 4-11). This mode only applies to channel 1 and will disable channel 2 when executed. The fast hardware filter for channel 1 is employed.

**4-56. Measure Fast Dual (MFD).** The measure fast dual channel mode of operation provides the instrument's fastest measurement response for both channels when addressed to talk over the IEEE bus. Measurements at a rate of 120 readings per second for each channel can be obtained. In this mode, the fast hardware filters for channel 1 and channel 2 are employed.

**4-57. Trigger Normal (TN).** In this mode, the front panel displays the -TRIG- message until the 9230 is triggered by a bus command. The instrument continuously measures power as in the measure normal mode but does not display the reading. When triggered, the instrument captures the most recent measurement and displays the reading until another trigger command changes the display. This mode provides a quick response to trigger and the capability to hold a reading until required. However, the user is required to assure stability of the reading at the time of trigger.

**4-58. Trigger Filtered (TF).** When entering this mode, the front panel displays the "-TRIG-" message. When a bus trigger command is received, the instrument begins the measure filtered mode. The 9230 displays the "-TRIG-" message until the digital filter time constant has elapsed. The instrument displays and holds the filtered reading

until another bus trigger command is received. In this mode, the digital filter guarantees a filtered reading upon trigger and the capability to hold a reading until required.

**4-59. Trigger Settled (TS).** When this mode is entered the front panel displays the "-TRIG-" message. The measure settled mode begins when a bus trigger command (GET) is received. The "-TRIG-" message will continue to be displayed until the settled condition occurs. The minimum time for a settled reading is twice the selected filter time constant. The maximum time is unlimited, because the settled condition may never occur for noisy signals or constantly varying signals. In a data acquisition system this mode should be used only in connection with a bus service request ((SRQ) to signal the controller when the measurement is complete. This allows the user's program to limit the time allowed for settling and take appropriate action if it is not achieved. Otherwise, an unsettled condition may hold off the GPIB indefinitely.

**4-60. Trigger Fast Single (TFS).** When the TFS command is executed, the front panel displays the "-TRIG-" message. Once a bus trigger command is received, the instrument begins the fast single channel measurement mode of operation. The "-TRIG-" message is displayed until the completion of the measurement. Triggered response times of 5 ms may be obtained (see Figure 4-11). This mode only applies to channel 1 and will disable channel 2 when executed. The fast hardware filter for channel 1 is employed.

**4-61. Trigger Fast Dual (TFD).** When the TFD command is executed, the front panel displays the "-TRIG-" message. Once a bus trigger command is received, the instrument begins the fast dual channel measurement mode of operation. The "-TRIG-" message is displayed until the completion of the measurement. Triggered response times of 10 ms may be obtained. In this mode, the fast hardware filters for channel 1 and channel 2 are employed.

#### 4-62. IEEE PROGRAMMING EXAMPLES.

#### 4-63. REMOTE OPERATION, RS-232 INTERFACE.

**4-64. General.** RS-232 interface is available for the Model 9230 in lieu of the IEEE-488. The command set and data transfer protocol are nearly identical to those for the GPIB option. The Menu-SETUP-RS-232 is used to configure the RS-232 interface to comply with the terminal in use. Setting the end-of-string character and SRQ Mask is accomplished by using the EOS Talker/Listener and SRQ Mask commands respectively.

**4-65. Entering the Remote Mode.** The Model 9230 enters the remote mode when the ASCII "SI" character (hexadecimal 0F/CTRL O) is received. In the remote state, the front panel keyboard is disabled, except for the

<Menu> key which serves as the return to local function. The display will show the REM indicator on the last line and enable the TLK, LSN and SRQ as appropriate.

**NOTE**

Do not confuse the ASCII control characters "SI" and "SO" with the Sensor command strings SI and S 0 . The former are non-printing control codes, the latter 2 character literal strings.

**4-66. Returning to Local Mode.** The instrument will return to the local state when;

- a. The <Menu> key is pressed.
- b. The ASCII "SO" character (hexadecimal 0E/CTRL N) is received.

**NOTE**

The instrument must be placed in the remote state for it to respond to data messages. It is not possible to store data in the local state for execution in the remote state.

**4-67. Talk Operations.** The Model 9230 can be requested to talk in two ways. The "??" mnemonic is available for requesting data via the RS-232 port. Immediately after receiving this mnemonic, the instrument responds by transmitting data based on the current talk mode. For example, the following interactive sequence causes the Model 9230 to transmit the measurement with the associated units:

| <u>Terminal Sends</u>     | <u>Model 9230 Response</u>  |
|---------------------------|---|
| O (CTRL O/hexadecimal 0F) | REM annunciator illuminates, indicating remote operation.   |
| DB TM1 ??<ENTER>          | Set measurement to dBm, set the talk mode to 1 (talk measurement with units), talk.<br><br>0,-3.00 dBm - No error at -3 dBm |

**NOTE**

<ENTER> means transmit end-of-string as defined via the Menu-SETUP-RS 232-EOS Listener parameter (typically CR).

**4-68.** Additionally, the ASCII "DC2" character (hexadecimal 12/CTRL R) will cause the instrument to immediately transmit data based on the current talk mode. Continuing the above example:

| <u>Terminal Sends</u>     | <u>Model 9230 Response</u>   |
|---------------------------|--|
| TM0 <ENTER>               | Set the talk mode to send Floating Point Measurements.   |
| R (CTRL R/hexadecimal 12) | Talk the error flag and the measurement in floating point notation.<br><br>0,-3.00 - no error, power is -3 dBm |

**4-69.** The rules for number and data strings are the same as for the IEEE-488 interface. Number formats are free form and data strings are case insensitive.

**TABLE 4-6. ERROR MESSAGES**

| Error Message Code | Description  |
|--------------------|--|
| 0                  | No Errors  |
| 1                  | Number entry out of range for parameter set.   |
| 2                  | Unused   |
| 3                  | -LO- indication on display. Is caused by<br>a. Power level below amount allowed in dBm display during autorange<br>b. Power level below amount allowed for range set in watts or dBm display.                                    |
| 4                  | -HI- indication on display. Is caused by<br>a. Power level above amount allowed in dBm display during autorange.<br>b. Power level above amount allowed for range set in watts or dBm display.                                   |
| 5                  | Occurs when input channel attempts to autorange below the range 0. Caused by incorrect zeroing of channel or a sensor which is damaged or not connected.   |
| 6                  | Unable to zero instrument because power is applied to the sensor, the sensor is damaged, or the sensor is not connected.   |
| 7 thru 24          | Unused   |
| 25 thru 29         | Unused   |
| 30                 | The message string has exceeded 150 characters. All commands sent are ignored.   |
| 31                 | The command string sent has not been recognized by the instrument. If more than one command has been sent, the commands occurring before the unrecognized command have been executed, while subsequent commands will be ignored. |
| 32 thru 39         | Unused   |

**TABLE 4-7. SRQ MASK BITS**

| Bit | Description  |
|-----|--|
| 0   | Set bit indicates LOLIMIT alarm in CH1   |
| 1   | Set bit indicates that a measurement error has occurred  |
| 2   | Set bit indicates that either a Trigger Filtered or Trigger Settled measurement is ready             |
| 3   | Set bit indicates that a Zeroing command is complete   |
| 4   | Set bit indicates HI LIMIT alarm in CH1  |
| 5   | Set bit indicates LOLIMIT alarm in CH2   |
| 6   | Set bit indicates that an SRQ is active; this is a summary bit used in serial poll, not a masked bit |
| 7   | Set bit indicates HI LIMIT alarm in CH2  |

**TABLE 4-8. BOONTON 9230 GPIB COMMANDS**

| Code  | Description                                   | Comments                      |
|-------|---|-------------------------------|
| AM    | Measure CH1 - CH2                             | (dBmodes <=-99.99)            |
| AR    | Measure CH1/CH2                               |                               |
| BD    | Measure CH2-CH1                               | (dB modes <=-99.99)           |
| BR    | Measure CH2/CH1                               |                               |
| CH    | Channel select                                | 1 - 2                         |
| CL    | Clear   |                               |
| DB    | dBm select                                    |                               |
| DF    | Display off                                   |                               |
| DN    | Display on                                    |                               |
| DR    | dBr select                                    |                               |
| DU    | Display user message                          | (Use DN to cancel)            |
| FA    | Auto filter                                   |                               |
| FL    | Filter time select                            | 0 to 20.00 in 0.05 steps      |
| ?ID   | Talk instrument ID                            |                               |
| *IDN? | Talk instrument ID                            |                               |
| LH    | High limit                                    | -99.99 to 99.99 in 0.01 steps |
| LL    | Low limit                                     | -99.99 to 99.99 in 0.01 steps |
| LM0   | Disable limits checking function              |                               |
| LM1   | Enable limits checking function               |                               |
| LR    | Load reference                                |                               |
| PK0   | Disable peak readout.                         |                               |
| PK1   | Peak sinewave voltage                         | (x.1414 or +3dB)              |
| VOLT  | Volts units select                            | ( $\mu$ V, mV)                |
| MF    | Measure filtered                              |                               |
| MFD   | Measure Fast Dual Channels                    | (9232 only)                   |
| MFS   | Measure fast single channel                   |                               |
| MN    | Measure normal, free run                      |                               |
| MS    | Measure settled                               |                               |
| PW    | Watts select                                  |                               |
| RA    | Autorange                                     |                               |
| RB    | Recorder bottom                               |                               |
| RC    | Recall instrument configuration               | 1 - 4                         |
| RE    | Resolution - select bus number decimal places | 1 - 3                         |

**TABLE 4-8. BOONTON 9230 GPIB COMMANDS (CONT.)**

| <b>Code</b> | <b>Description</b>                 | <b>Comments</b>               |
|-------------|------------------------------------|-------------------------------|
| RN          | Recorder normal                    |                               |
| RS          | Range select                       | 0-07                          |
| RT          | Recorder top (use RN to cancel)    |                               |
| VSI         | Send linearity data to instrument  |                               |
| SM          | Service request (SRQ) mask         | 0-255                         |
| VSO         | Get linearity data from instrument |                               |
| SR          | Set dBr reference                  | -99.99 to 99.99 in 0.01 steps |
| SS          | Sensor select                      | 1 - 6                         |
| ST          | Store instrument configuration     | 1 - 4                         |
| TF          | Trigger filtered                   |                               |
| TFD         | Trigger fast dual channels         | (9232 Only)                   |
| TFS         | Trigger fast single channel        |                               |
| TN          | Trigger normal                     |                               |
| TM          | Talk mode                          | 0 - 6                         |
| TR          | Bus trigger                        |                               |
| TS          | Trigger settled                    |                               |
| ZR          | Instrument zero                    |                               |
| Z0          | Set characteristic impedance       | 5-2500                        |
| XT0         | X100 Divider not used              |                               |
| XT1         | x100 divider installed             |                               |