

**Instruction Manual
for**



**Model 1660A
Triple Output
DC POWER SUPPLY**



BK PRECISION®

MAXTEC INTERNATIONAL CORP.

6470 W. Cortland St. • Chicago, IL 60635

TABLE OF CONTENTS

	page
TEST INSTRUMENT SAFETY	inside front cover
INTRODUCTION.....	3
FEATURES	5
SPECIFICATIONS	6
CONTROLS AND INDICATORS	7
General Controls And Indicators	7
4-6.5 V Supply Controls And Indicators	7
Master Supply Controls And Indicators	7
Slave Supply Controls And Indicators	9
Rear Panel Controls	10
OPERATING INSTRUCTIONS	11
Safety Precautions	11
Equipment Precautions	11
Independent Use Of "Master" Or "Slave" Supply	11
Series Tracking Operation	15
Parallel Tracking Operation	16
4-6.5 V Power Supply Operation	18
APPLICATIONS	22
General	22
Electronics Servicing	22
Electronics Manufacturing	22
Electronics Design Lab	22
Electronics Education	23
Battery Charging	23
Split Supply	23
MAINTENANCE	27
Fuse Replacement	27
Line Voltage Conversion	27
Adjustments	28
Master Supply and Master Metering Adjustments	28
4-6.5 V Supply and 4-6.5 V Metering Adjustments	30
Slave Supply and Metering Adjustments	30
Slave Series Tracking Adjustment	31
Tracking Parallel Current Adjustment	31
Instrument Repair Service	31
WARRANTY SERVICE INSTRUCTIONS	32
LIMITED ONE-YEAR WARRANTY	33

INTRODUCTION

The **B+K Precision Model 1660A Triple Output DC Power Supply** is a high quality, general purpose dc power source. It provides two supplies with a 0-30 volt dc output and one with a 4-6.5 volt dc output. The 0-30 V supplies are adjustable with both coarse and fine voltage controls for precise settability and are capable of current output of 0-2 amps. The 4-6.5 V supply has a current output of 0-5 amps, allowing it to handle extensive digital logic circuitry. Two large panel-mounted LED meter displays can monitor either the output current or output voltage of each supply.

The two 0-30 volt supplies can be operated independently or in one of two tracking modes. In the series tracking mode, the Slave supply tracks the voltage of the Master supply. Maximum current setting of the two supplies can still be set independently when in the series tracking operating mode. In the series tracking mode the Master and Slave supplies are connected in series, allowing a single output of 0-60 V at up to 2 amps. In the parallel tracking mode, the two supplies are connected together in parallel, allowing a single 0-30 V output at up to 4 amps.

Both 0-30 volt supplies may be used in constant voltage or constant current applications. The crossover from constant voltage to constant current modes is smooth and automatic. LED's indicate the "CV" (constant voltage) or "CC" (constant current) mode of operation. In constant voltage applications, a current limit may be preset. When load variations cause the current to reach the preset limit, the unit then regulates output current rather than output voltage. Current limits are adjustable from 0 to 100% of maximum. In constant current applications, the maximum voltage may be preset. When load variations cause current to drop below the regulated value, the unit reverts to regulated voltage operation at the preset value.

The 4-6.5 V supply is ideal for powering digital logic circuitry. The 0-5 amp capacity allows the supply to be used for large circuits. Built-in overload protec-

tion automatically limits to current output to a maximum of 5 amps. An indicator lights when the supply is overloaded.

The Model 1660A exhibits excellent regulation and low ripple characteristics. The circuit design incorporates a pre-regulator, which greatly reduces internal power dissipation at low output voltages.

Reverse polarity protection prevents accidental damage to the power supply from improper connection to an external voltage, and current limiting protects the equipment being powered, as well as the power supply.

The output is isolated from chassis and earth ground, which permits full flexibility of connections. When needed, the (+) or (-) polarity may be strapped to ground, or either polarity may be floated to an external voltage. Additionally, the two 0-30 volt supplies can be used as a "split supply" with two positive voltages and a common negative, two negative voltages and a common positive, or one positive, one negative, and a common. All of these configurations can be used with either matching (tracking) or differing (independent) voltages.

The features and versatility of the unit, especially the triple output and tracking features, make it an ideal general purpose power supply for engineering lab applications. It can serve as a single or multi-voltage power source, including the bias supply, for breadboard and prototype circuits and equipment. It can provide single or simultaneously varying voltages for circuit evaluation. It can provide tracking (+) and (-) voltages for evaluating differential amplifiers. It may be used as a battery eliminator, or to power individual circuit boards or cards while removed from the system. Its output can be evaluated while powering a breadboard or prototype circuit to determine the circuit's power supply requirements. Its laboratory quality specifications will meet most engineering laboratory requirements.

INTRODUCTION

The same features that make the Model 1660A a good choice for an engineering lab also make it a good choice for most other solid state electronic applications. These applications include service

shops; industrial production testing of components, assemblies, and complete equipment; for school laboratories, and home use by electronic hobbyists.

FEATURES

TRIPLE OUTPUT

Operates as three separate power supplies. Each has floating output and is completely isolated from the other two.

ONE 4 TO 6.5 V SUPPLY

Husky 0-to-5 amp 4-to-6.5 volt supply is ideal for use with most digital logic circuitry. Adequate current capacity for extensive circuitry.

TWO 0-30 VOLT SUPPLIES

Master and Slave supply are continuously variable over 0-to-30 volt range with coarse and fine controls. Each supply has a 2 amp current capacity.

UNIQUE TRACKING FEATURE

The two 0-to-30 V supplies can be operated so that the Slave supply tracks the Master supply. Outputs can be strapped for two positive voltages with a common negative, two negative voltages with a common positive, or one positive and one negative with a neutral common.

SINGLE 0-60 V SUPPLY

Series tracking feature allows use of Master and Slave supplies as one 0-to-60 V, 2 amp supply.

SINGLE 0-30 V 4 AMP SUPPLY

Parallel tracking feature allows use of Master and Slave supply as a 0-to-30 V supply with a 4 amp current capacity (through Master output terminals).

CONSTANT VOLTAGE OR CONSTANT CURRENT

The Master and Slave supplies provide regulated dc voltage output or regulated dc current output. Cross-over is smooth and automatic.

LED DISPLAY

Two large, easy-to-read LED 3-1/2 digit displays monitor output voltage or output current of all three supplies. Use of two meters allows simultaneous current and voltage metering when use Master and Slave supplies in tracking operation. Good visibility in bright or low light. Meter allows resolution of 0.1 volt or 0.01 amp.

LABORATORY QUALITY

Excellent regulation, low ripple.

LED INDICATORS

Identify mode of operation.

PRE-REGULATOR

Limits internal dissipation for higher reliability and efficiency.

ISOLATED OUTPUT

Either polarity may be floated or grounded.

OVERLOAD PROTECTION

Fully adjustable current limiting (from 0 to 100% of maximum output current) for Master and Slave supplies protects circuit under test and the power supply.

REVERSE POLARITY PROTECTION

Prevents damage to power supply from external voltage of reverse polarity.

HOOK-UP CABLES

Supplied with three sets of red and black hook-up leads.

SPECIFICATIONS

MASTER AND SLAVE SUPPLIES

Output Voltage Range:

0 V (+0/-30 mV) to 30 V + (3% to 7%).

Output Current Limit Range:

0 A (+0/-30 mA) to 2 A +(3% to 7%).

Load Regulation (Constant Voltage):

$\leq 0.01\% + 3 \text{ mV}$.

Line Regulation 108 - 132 V (Constant Voltage):

$\leq 0.01\% + 3 \text{ mV}$.

Ripple (Constant Voltage):

$\leq 1 \text{ mV RMS}$.

Recovery Time (Constant Voltage):

$\leq 100 \mu\text{s}$.

Temp. Coefficient (Constant Voltage):

$\leq 300 \text{ ppm}/^\circ\text{C}$.

Load Regulation (Constant Current):

$\leq 0.2\% + 3 \text{ mA}$.

Line Regulation 108 - 132 V (Constant Current):

$\leq 0.2\% + 3 \text{ mA}$.

Ripple Current (at 108 V for Constant Current):**Current):**

$\leq 3 \text{ mA RMS}$.

Tracking (Series):

$\pm 0.2\% + 10 \text{ mV}$.

Panel Meter Accuracy (Volts):

$\pm 0.5\% + 2 \text{ digits}$.

Panel Meter Accuracy (Current):

$\pm 0.5\% + 2 \text{ digits}$.

4-6.5 V SUPPLY

Output Voltage Range:

4 V $\pm 5\%$ to 6.5 V $\pm 5\%$.

Load Regulation (Constant Voltage):

$\leq 10 \text{ mV}$ (0 to 5 A load).

Line Regulation 108 - 132 V (Constant Voltage):

$\leq 10 \text{ mV}$.

Ripple And Noise:

$\leq 2 \text{ mV RMS}$.

Overvoltage Protection Threshold:

6.8 V to 7.3 V.

Panel Meter Accuracy:

Same as Master Supply Meter.

GENERAL

Power Requirements:

110/120/220/240 VAC $\pm 10\%$, 50/60 Hz.

Power Consumption (Fully Loaded):

Approximately 320 W.

Protection:

Reverse polarity protection and current limiting.

Dimensions (H x W x D):

165 x 315 x 381 mm (12.4 x 15 x 6.5").

Weight:

10 kg (22 lbs).

Accessories Supplied:

Three sets of hook-up leads, 1 red, 1 black.

Two earth ground bus straps.

Two 5A, 250V fuses (spares).

Optional Accessories:

FP-10 10-amp hook-up leads (1 red, 1 black).

CONTROLS AND INDICATORS

GENERAL CONTROLS AND INDICATORS

1. **POWER Switch.** Turns power on and off. When power is on, switch is internally illuminated to serve as a pilot light.
2. **TRACKING Mode Switches.** Two pushbutton switches that select **INDEP**endent mode, series tracking mode, or parallel tracking mode as follows:
 - a. When both switches are disengaged (out), the unit is in the **INDEP**endent mode and the **MASTER** and **SLAVE** power supplies are completely independent from one another.
 - b. When the left switch is engaged (in) and the right switch is disengaged (out), the unit is in the **TRACKING SERIES** mode. In this mode, maximum voltage of both supplies is set using the **MASTER VOLTAGE** controls (voltage at output terminals of the **SLAVE** supply tracks the voltage at the output terminals of the **MASTER** supply). Also, in this mode of operation the positive terminal (red) of the **SLAVE** supply is connected to the negative terminal (black) of the **MASTER** supply. This allows the two supplies to be used as one 0-to-60 volt supply.
 - c. When both switches are engaged (in), the unit is in the **TRACKING PARALLEL** mode. In this mode the **MASTER** and **SLAVE** supplies are wired together in parallel and both the maximum current and voltage are set using the **MASTER** controls. The **MASTER** and **SLAVE** outputs can be used as two individual (but tracking) power supplies or just the **MASTER** output can be used as a 0-to-30 volt supply with a 4 A capability.
3. **0-30 V/4-6.5 V Switch.** Controls **MASTER/4-6.5 V LED Display**. When this switch is in the **0-30 V** position, the LED display monitors the **MASTER** (0-30 V) supply. When this switch is in the **4-6.5 V** position, the LED display monitors the 4-6.5 V supply.
4. **A/V Switch.** Selects current or voltage metering mode for the **MASTER** 0-30 V supply or the **4-6.5 V** supply (depending on setting of **0-30 V/4-6.5 V** switch). When in the **A** (amps) position, current is read from the **MASTER/4-6.5 V LED Display**. When in the **V** (volts) position, voltage is read from the **MASTER/4-6.5 V LED Display**.
5. **MASTER/4-6.5 V LED Display.** Digital display indicates voltage or current at the 0-30 V **MASTER** supply or the 4-6.5 V supply (depending on the setting of the **MASTER A/V** and **0-30 V/4-6.5 V** switches).

4-6.5 V SUPPLY CONTROLS AND INDICATORS

6. **“-” Terminal (Black).** Negative polarity output terminal for 4-6.5 V supply.
7. **“+” Terminal (Red).** Positive polarity output terminal for 4-6.5 V supply.
8. **Voltage Level Control.** Adjusts output voltage for 4-6.5 V supply. Fully counterclockwise rotation adjusts output voltage to 4 V. Clockwise rotation increases voltage to a maximum of 6.5 V (full clockwise rotation).
9. **5 A OVERLOAD Indicator.** Lights when load on 4-6.5 Volt supply becomes too large.

MASTER SUPPLY CONTROLS AND INDICATORS

10. **C.C. (Constant Current) Indicator.** Red LED lights when **MASTER** supply is in the Constant Current mode. The Power Supply regulates the output current at the value set by the **MASTER CURRENT** control. In the Parallel Tracking mode, when this indicator is lit, both the **MAS-**

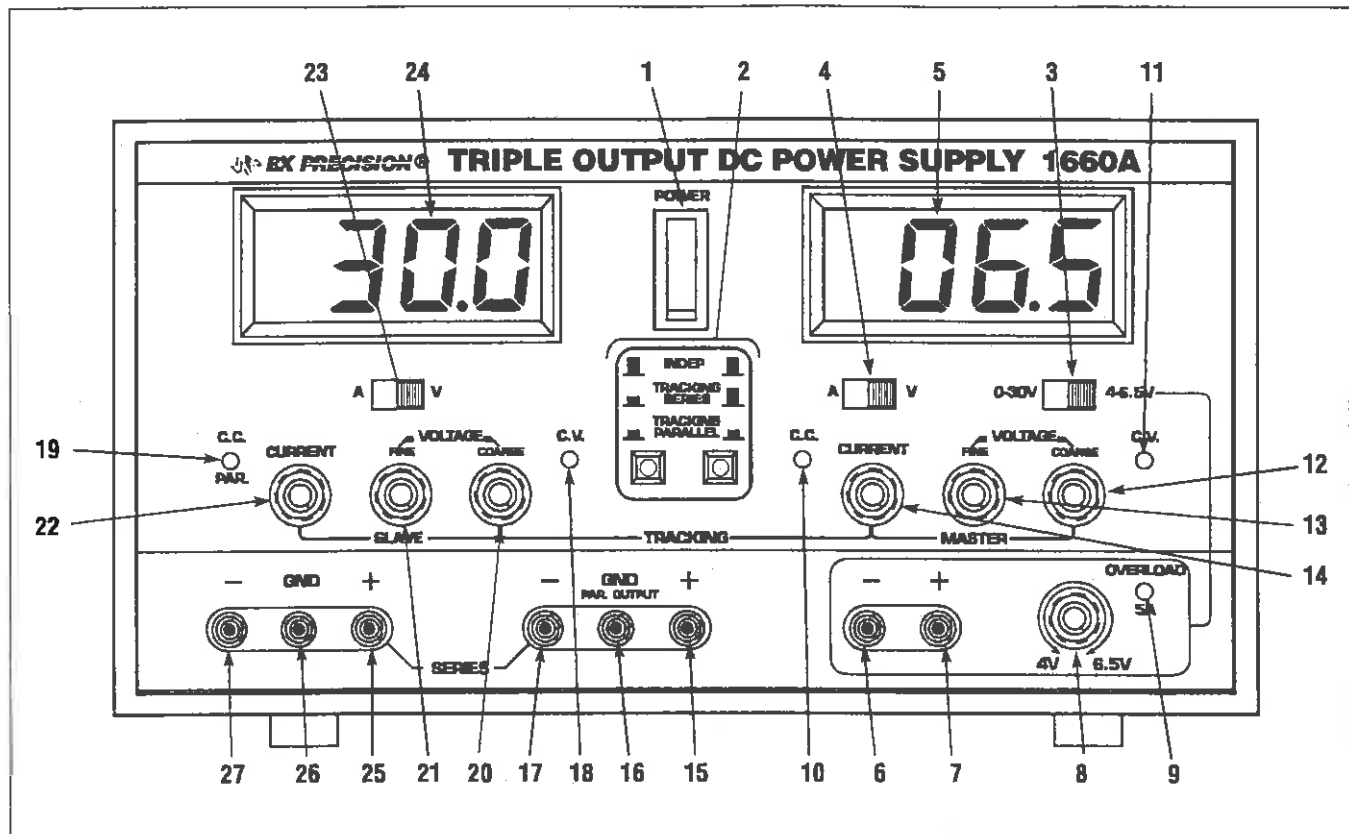

Fig. 1. Front Panel Controls And Indicators.

TER and SLAVE supplies are in the Constant Current mode.

11. **C.V. (Constant Voltage) Indicator.** Green LED lights when the MASTER supply is in the Constant Voltage mode. The Power Supply regulates the output voltage at the value set by the MASTER VOLTAGE controls. In either the Series or Parallel Tracking mode, when this indicator is lit, both the MASTER and SLAVE supplies are in the Constant Voltage mode.
12. **COARSE VOLTAGE Control.** Coarse adjustment of the output voltage of the MASTER supply. Also functions as coarse adjustment control for the maximum output voltage of the SLAVE supply when either parallel or series tracking mode is selected. Read the value on the MASTER/4-6.5 V LED Display when the voltage (V) and master (0-30 V) metering modes are selected.
13. **FINE VOLTAGE Control.** Fine adjustment of output voltage of the MASTER supply. Also func-

tions as fine adjustment control for the maximum output voltage of the SLAVE supply when either parallel or series tracking mode is selected. Read the value on the MASTER/4-6.5 V LED Display when the voltage (V) and master (0-30 V) metering modes are selected.

14. **CURRENT Control.** Adjusts current limit of MASTER supply in constant voltage mode. Adjusts constant current value of MASTER supply in constant current mode. Current can be read from the MASTER/4-6.5 V LED Display when the current (A) and master (0-30 V) metering modes are selected.
15. **“+” Terminal (Red).** Positive polarity output terminal for the MASTER supply. Also serves as the positive polarity terminal for 4 A parallel and 0-to-60 V series tracking operation.
16. **GND Terminal (Green).** Earth and Chassis Ground.

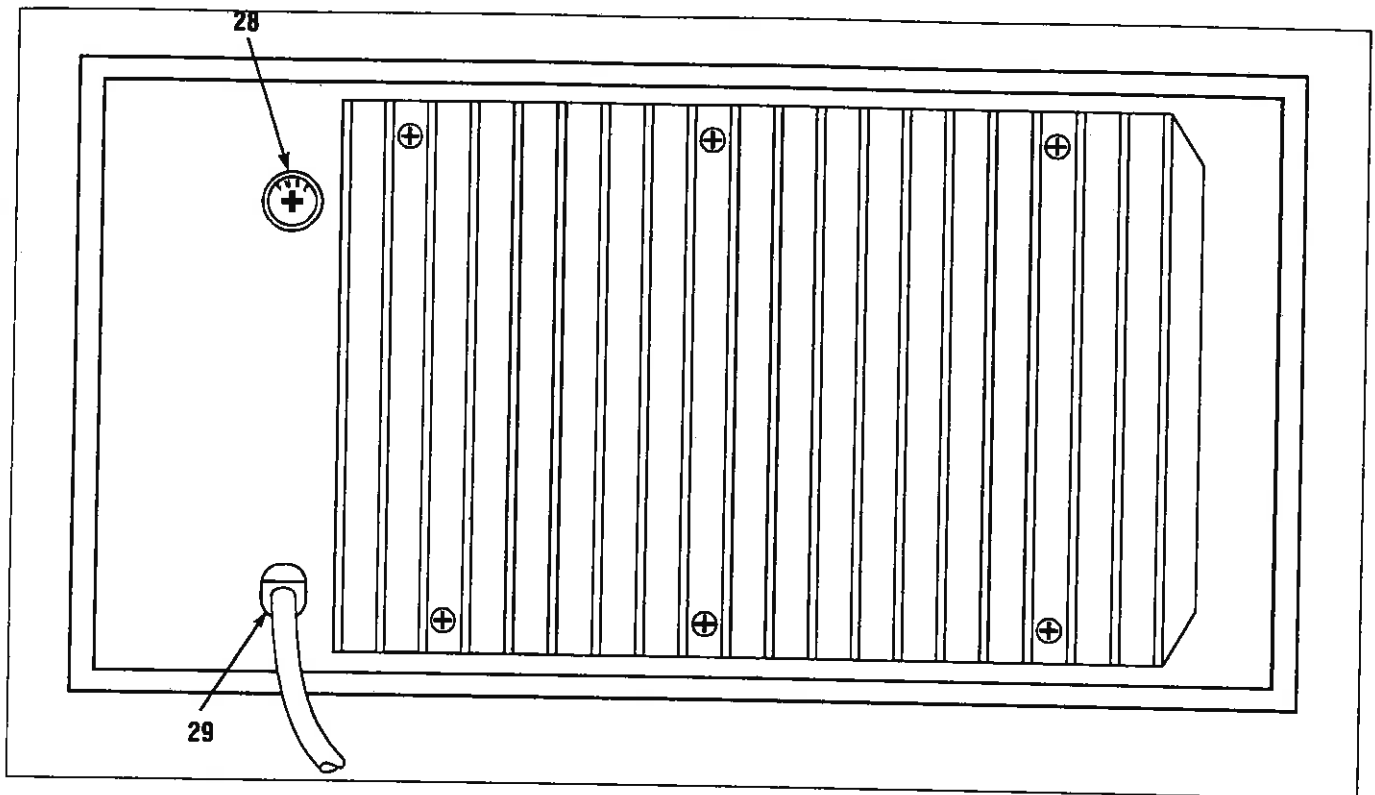

Fig. 2. Rear Panel Controls.

17. “-” Terminal (Black). Negative polarity output terminal for the **MASTER** supply. Also serves as the negative polarity terminal for 4 A parallel tracking operation. In series tracking operation, this terminal is internally tied to the (+) positive terminal of the **SLAVE** supply.

SLAVE SUPPLY CONTROLS AND INDICATORS

18. **C.V. (Constant Voltage) Indicator.** Green LED lights when the **SLAVE** supply is in the Constant Voltage mode. The Power Supply regulates the output voltage at the value set by the **SLAVE VOLTAGE** controls.
19. **C.C. (Constant Current)/PARAllel Indicator.** Red LED lights when **SLAVE** supply is in the Constant Current mode. The Power Supply regulates the output current at the value set by the **SLAVE CURRENT** control when in the series tracking or **INDEPendent** modes. Also lights when the **TRACKING PARALLEL** mode is selected.
20. **COARSE VOLTAGE Control.** Coarse adjustment of the output voltage of the **SLAVE** supply when the **INDEPendent** mode is selected. Read the value on the **SLAVE LED Display** when the voltage (V) metering mode is selected.
21. **FINE VOLTAGE Control.** Fine adjustment of output voltage of the **SLAVE** supply when the **INDEPendent** mode is selected. Read the value on the **SLAVE LED Display** when the voltage (V) metering mode is selected.
22. **CURRENT Control.** Adjusts current limit of **SLAVE** supply in constant voltage mode. Adjusts constant current value of **SLAVE** supply in constant current mode. Current can be read from the **SLAVE LED Display** when the current (A) metering mode is selected.
23. **A/V Switch.** Selects current or voltage metering mode for the 0-30 V **SLAVE** supply. When in the **A** (amps) position, current is read from the **SLAVE LED Display**. When in the **V** (volts) position, voltage is read from the **SLAVE LED Display**.

CONTROLS AND INDICATORS

24. **SLAVE LED Display.** Digital display indicates voltage or current at the 0-30 V **SLAVE** supply (depending on the setting of the **A/V** switch).
25. **“+” Terminal (Red).** Positive polarity output terminal for the **SLAVE** supply. In series tracking operation, this terminal is connected to the negative terminal of the **MASTER** supply.
26. **GND Terminal (Green).** Earth and Chassis Ground.
27. **“-” Terminal (Black).** Negative polarity output terminal for the **SLAVE** supply. Also serves as the negative polarity terminal for 0-to-60 V series tracking operation.

REAR PANEL CONTROLS

28. **Fuse.**
29. **Line Cord.**

OPERATING INSTRUCTIONS

SAFETY PRECAUTIONS

CAUTION

Avoid contacting the heat sink at the rear of the power supply. When the unit is providing large amounts of current at any or all of its outputs, the heat sink can become very hot. Contacting the heat sink when it is hot could result in skin burns or damage to the equipment in contact with them.

Use only a polarized 3-wire ac outlet. This assures that the power supply chassis, case, and ground terminal are connected to a good earth ground and reduces danger from electrical shock.

There may be great danger of electrical shock if the power supply output is connected to an external high voltage. Some equipment being powered may contain high voltage and present a shock hazard. Observe caution. If the power supply output is floated (referenced to a voltage rather than earth ground) turn off the power supply and the equipment under test when making connections. Never float the power supply to a potential greater than 100 volts peak with respect to earth ground.

EQUIPMENT PRECAUTIONS

Avoid using the power supply in ambient temperatures above +40° C. Always allow sufficient air space around the heat sink at the rear of the power supply for effective radiation to prevent internal heat build-up.

Although the power supply is protected against reverse polarity damage, the circuit being powered may not include such protection. Always carefully observe polarity; incorrect polarity may damage the equipment under test.

Do not exceed the voltage rating of the circuit being powered. Many transistors and integrated circuits will not withstand voltage of 30 volts.

There is no need to worry about voltage spikes or overshoot damaging the equipment under test. The voltage between the output terminals of the power supply never exceeds the preset value as the **POWER** switch is turned on or off.

INDEPENDENT USE OF "MASTER" OR "SLAVE" SUPPLY

The "**MASTER**" and "**SLAVE**" supplies each provide a 0-to-30 volt output at up to 2.0 amps. This procedure covers the use of the **MASTER** and **SLAVE** supplies only when they are used independently from one another. When used in the **INDEPENDENT** operating mode, the operating controls of the two power supplies are completely independent and either supply can be used individually or both can be used simultaneously. Basic operation is covered here. Several variations are covered in the **APPLICATIONS** section of this manual.

Hook-up

1. Disengage both **TRACKING** mode switches (both switches out) so that the power supply is in the **INDEPENDENT** operating mode.
2. Turn off the power supply and the equipment to be powered during hook-up.
3. Connect the positive polarity of the device being powered to the red (+) terminal of the power supply.
4. Connect the negative polarity of the device being powered to the black (-) terminal of the power supply.
5. Fig. 3 illustrates the grounding possibilities when used in the **INDEPENDENT** mode.

OPERATING INSTRUCTIONS

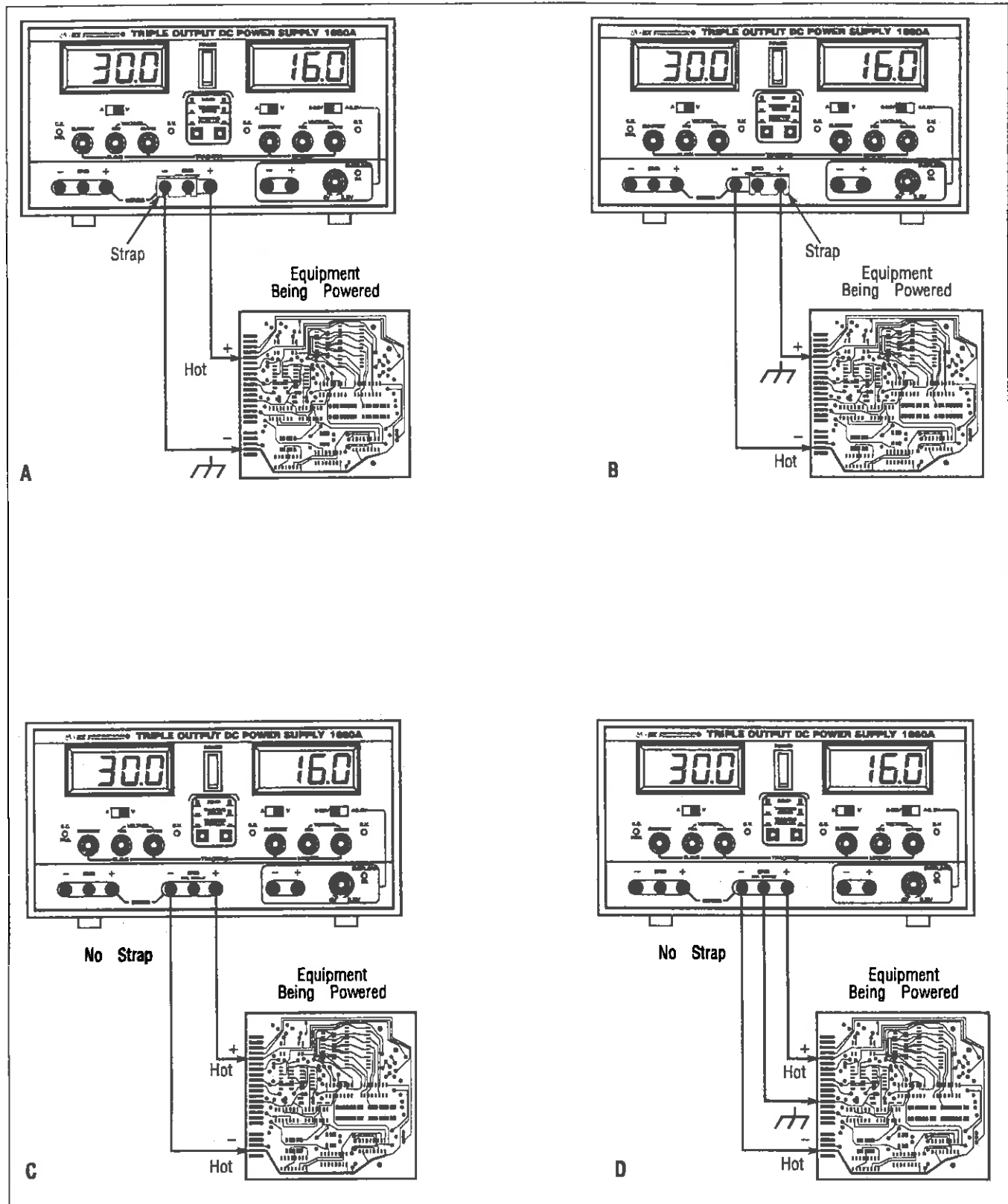

Fig. 3. Independent Operation Grounding Possibilities.

- a. If the negative polarity of the equipment or circuit being powered is also the chassis or common, it may be grounded to earth by strapping the black (-) terminal to the green (GND) terminal as shown in Fig. 3A.
 - b. Similarly, the positive polarity can be grounded by strapping the red (+) terminal to the green (GND) terminal as shown in Fig. 3B.
 - c. If an earth ground reference is not required, the configuration of Fig. 3C may be used. The scheme in Fig. 3C should also be used where it is not known whether the chassis is common with either the positive or negative polarity.
 - d. If the chassis or common of the equipment being powered is separate from both the positive and negative polarity power inputs, use the connection shown in Fig. 3D.
6. Observe proper polarity. If the circuit being powered is not equipped with reverse polarity protection, damage to the circuit can result from reverse polarity. Use color coded hook-up leads, such as the sets supplied with the power supply, for convenience in identifying polarity, red for (+) and black for (-).
 7. Make sure that the hook-up leads offer sufficient current capability and low resistance between the power supply and the circuits being powered. The hook-up leads supplied with the power supply are rated for 3 amps.

Typical Constant Voltage Operation

1. Before connecting the device to be powered to the power supply, determine the maximum safe load current for the device to be powered and set the current limit value (see "Setting Current Limit" procedure in this section).
2. Set **FINE VOLTAGE** control to center and **COARSE VOLTAGE** control to minimum (fully counterclockwise).

3. Turn off power supply and connect it to the device to be powered (see "Hook-Up" procedure in this section).
4. Turn on **POWER** switch. The **CV** indicator should light.
5. Set the meter selection switch to the **V** position to select the voltage metering mode.
6. Increase the **VOLTAGE** setting until the LED display reads the desired value. The **FINE** control permits easier setting to a specific value.
7. Set the meter selection switch to the **A** position to select the current metering mode and note the load current on the display.
8. If the load current exceeds the preset current limit, the **CV** indicator will go off and the **CC** indicator will light. In this case, the power supply automatically switches to the constant current mode and further rotation of the **VOLTAGE** control will not increase the output voltage.

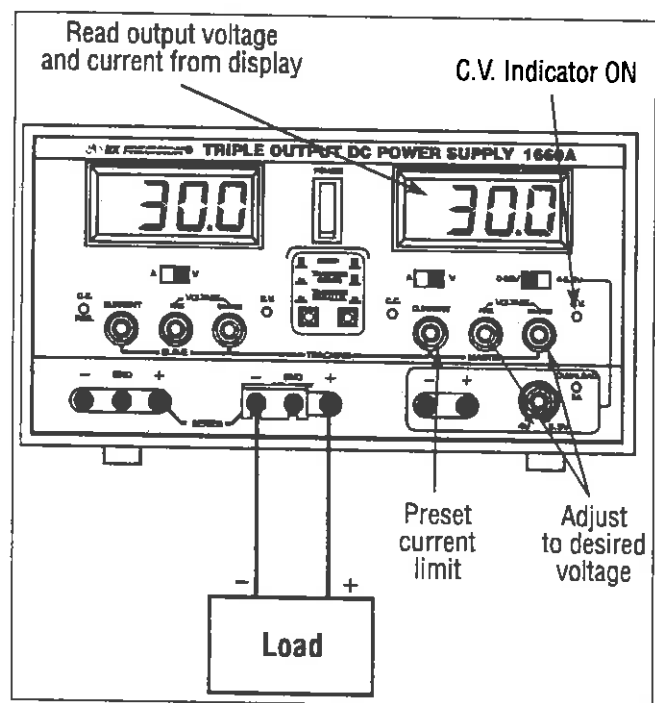

Fig. 4. Typical Constant Voltage Operation.

OPERATING INSTRUCTIONS

Setting Current Limit

1. Determine the maximum safe current for the device to be powered.
2. Temporarily short the (+) and (-) terminals of the power supply together with a test lead.
3. Rotate the **COARSE VOLTAGE** control away from zero sufficiently for the **CC** indicator to light.
4. Set the meter selection switch to the **A** position to select the current metering mode.
5. Adjust the **CURRENT** control for the desired current limit. Read the current value on the LED display.
6. The current limit (overload protection) has now been preset. Do not change the **CURRENT** control setting after this step.
7. Remove the short between the (+) and (-) terminals and hook up for constant voltage operation.

Typical Constant Current Operation

1. Before connecting the device to be powered to the power supply, determine the maximum safe voltage to be applied, set the meter selection switch to the **V** position, and set the **VOLTAGE** controls to obtain that voltage reading on the LED display.

2. Determine the desired constant current value.
3. Set the **CURRENT** control to minimum (fully counterclockwise).
4. Turn off the power supply and connect it to the device to be powered.
5. Turn on the power supply. The **CC** indicator should light.
6. Set the meter selection switch to the **A** position to obtain the current metering mode.
7. Increase the **CURRENT** control setting until the desired constant current value is read on the display, or set the current limit in advance (before connecting the load) as prescribed earlier in the "Setting Current Limit" procedure
8. If the load current drops below the constant current value, the **CC** indicator will go off and the **CV** indicator will light. In this case, the power supply automatically switches to the constant voltage mode, and further rotation of the **CURRENT** control will not increase the output current.

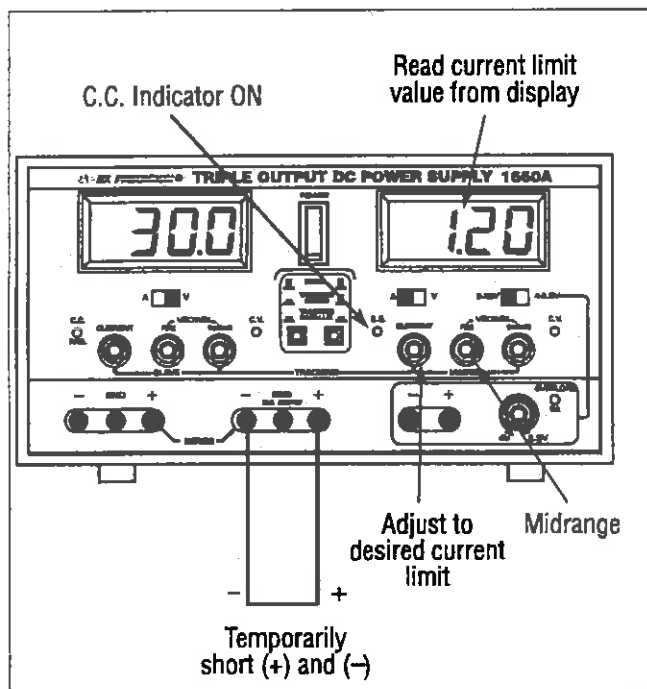

Fig. 5. Setting Current Limit.

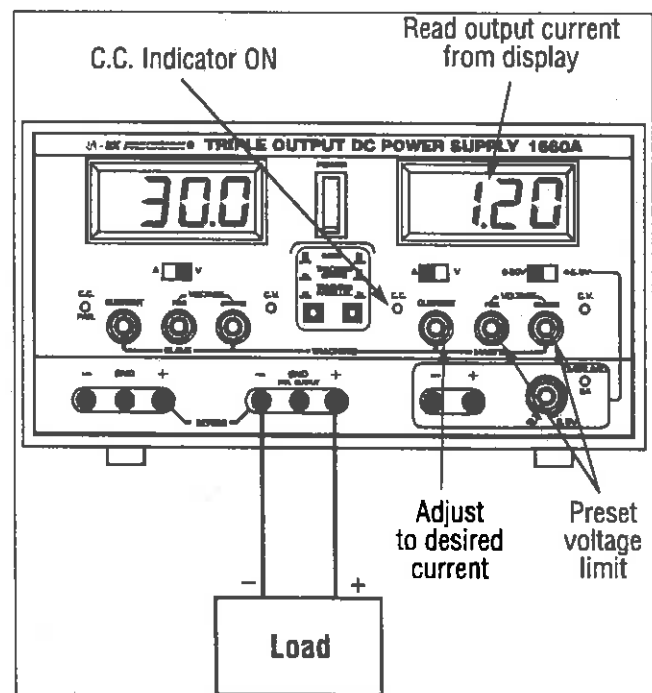

Fig. 6. Typical Constant Current Operation.

Constant Voltage/Constant Current Characteristic

The working characteristic of this power supply is called a constant voltage/constant current automatic crossover type. This permits continuous transition from constant current to constant voltage modes in response to the load change. The intersection of constant voltage and constant current modes is called the crossover point. Fig. 7 shows the relationship between this crossover point and the load.

For example, if the load is such that the power supply is operating in the constant voltage mode, a regulated output voltage is provided. The output voltage remains constant as the load increases, up until the point where the preset current limit is reached. At that point, the output current becomes constant and the output voltage drops in proportion to further increases in load. The crossover point is indicated by the front panel LED indicators. The crossover point is reached when the CV indicator goes off and the CC indicator comes on.

Similarly, crossover from the constant current to the constant voltage mode automatically occurs from a decrease in load. A good example of this would be seen when charging a 12-volt battery. Initially, the open circuit voltage of the power supply may be preset for 13.8 volts. A low battery will place a heavy load on the supply and it will operate in the constant current mode, which may be adjusted for a 1 amp charging rate. As the battery becomes charged, and

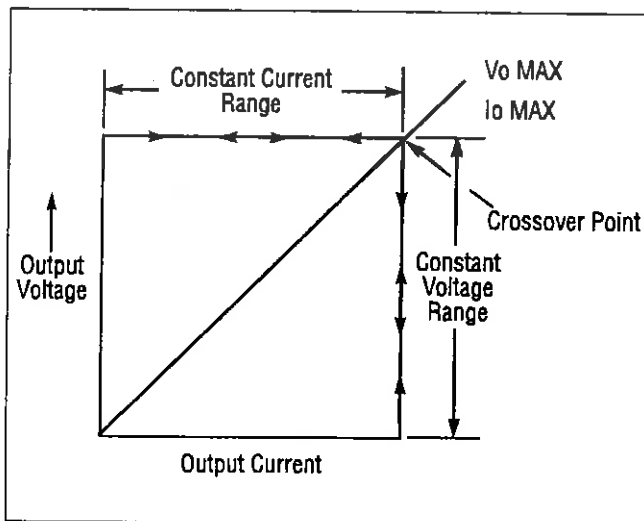

Fig. 7. Constant Voltage/Constant Current Characteristics.

its voltage approaches 13.8 volts, its load decreases to the point where it no longer demands the full 1 amp charging rate. This is the crossover point where the power supply goes into the constant voltage mode.

SERIES TRACKING OPERATION

When the series tracking mode of operation is selected, the positive (red) terminal of the **SLAVE** supply output is internally connected to the negative (black) terminal of the **MASTER** supply. This allows the power supply to be used as a single 0-to-60 volt power supply simply by using the negative (black) terminal of the **SLAVE** supply and the positive (red) terminal of the **MASTER** supply.

In the series tracking mode, the maximum output voltage of both the **MASTER** and **SLAVE** supplies can be simultaneously varied with one control. The maximum **SLAVE** supply voltage is automatically set to the same value as the **MASTER** supply by using the **MASTER VOLTAGE** controls.

Simultaneous metering of both current and voltage can be obtained in this mode of operation by setting one of the displays for current metering and one for voltage metering. In this case, the output voltage (across the two supplies) is actually double the displayed value. For example, if the **MASTER** display is set for voltage metering and the **SLAVE** display for current metering, the output voltage across the **MASTER** positive (red) terminal and the **SLAVE** negative (black) terminal would be double the reading on the **MASTER LED Display** (since both supplies are putting out the same voltage). The actual output current would be the value read from the **SLAVE LED Display** (since the two supplies are wired in in series, current flowing through each supply must be equal).

1. Set the power supplies to the **TRACKING SERIES** mode by engaging the left **TRACKING** switch and release the right **TRACKING** switch.
2. Set the **0-30 V/4-6.5 V** switch to the **0-30 V** position, the **MASTER A/V** switch to the **V** (voltage metering) position, and the **SLAVE A/V** switch to the **A** (current metering) position.
3. Set the **SLAVE CURRENT** control to the fully clockwise position. The maximum current is set

OPERATING INSTRUCTIONS

using the **MASTER CURRENT** control. Follow the instructions for "Setting Current Limit" (**INDEPENDENT USE OF "MASTER" OR "SLAVE" SUPPLY** section of this manual) using the **MASTER CURRENT** control.

NOTE

Because the supplies are being used in series, either **CURRENT** control can be used to set maximum current. If desired, the **MASTER CURRENT** control can be rotated fully clockwise and the **SLAVE CURRENT** control can be used to adjust the maximum current value. Because current through the two supplies must be equal when they are being used in series, the lowest **CURRENT** control setting will set the maximum output current.

4. Adjust the output voltage to the desired level using the **MASTER VOLTAGE** controls (remember that the actual output voltage is double the reading on the **MASTER LED Display**).
5. Turn off the power supply and the equipment to be powered during hook-up.
6. Connect the positive polarity of the device being powered to the red (+) terminal of the **MASTER** power supply.
7. Connect the negative polarity of the device being powered to the black (-) terminal of the **SLAVE** power supply.
8. Fig. 8 illustrates the grounding possibilities when the unit is used as a 0-to-60 volt supply.
 - a. If the negative polarity of the equipment or circuit being powered is also the chassis or common, it may be grounded to earth by strapping the black (-) terminal of the **SLAVE** supply to the green (**GND**) terminal of the **SLAVE** supply as shown in Fig. 8A.
 - b. Similarly, the positive polarity can be grounded by strapping the red (+) terminal of the **MASTER** supply to the green terminal of the **MASTER** supply as shown in Fig. 8B.

- c. If "split supply" operation is desired, a positive and negative voltage with a center ground can be achieved by strapping the black (-) terminal of the **MASTER** supply to the green (**GND**) of the **MASTER** supply as shown in Fig. 8C. See the **APPLICATIONS** section of this manual for more information on "split supply" operation.

NOTE

If one of the supplied ground straps is to be used, only use it in one of these three ways. Connecting two ground straps could ground both the positive and negative terminals and load down the power supply, causing improper operation.

- d. If an earth ground reference is not required, the configuration of Fig. 8D may be used. The scheme in Fig. 8D should also be used where it is not known whether the chassis is common with either the positive or negative polarity.
 - e. If the chassis or common of the equipment being powered is separate from both the positive and negative polarity power inputs, use the connection shown in Fig. 8E.
9. Observe proper polarity. If the circuit being powered is not equipped with reverse polarity protection, damage to the circuit can result from reverse polarity. Use color coded hook-up leads, such as the sets supplied with the power supply, for convenience in identifying polarity, red for (+) and black for (-).
 10. Make sure that the hook-up leads offer sufficient current capability and low resistance between the power supply and the circuits being powered. The hook-up leads supplied with the power supply are rated for 3 amps.

PARALLEL TRACKING OPERATION

In the parallel tracking mode of operation, both supplies are strapped together (in parallel). This allows for a 0-30 V supply with a 4 amp current capability. Only the **MASTER** output terminals are used for parallel tracking operation. In the parallel tracking mode, the **SLAVE** supply output voltage

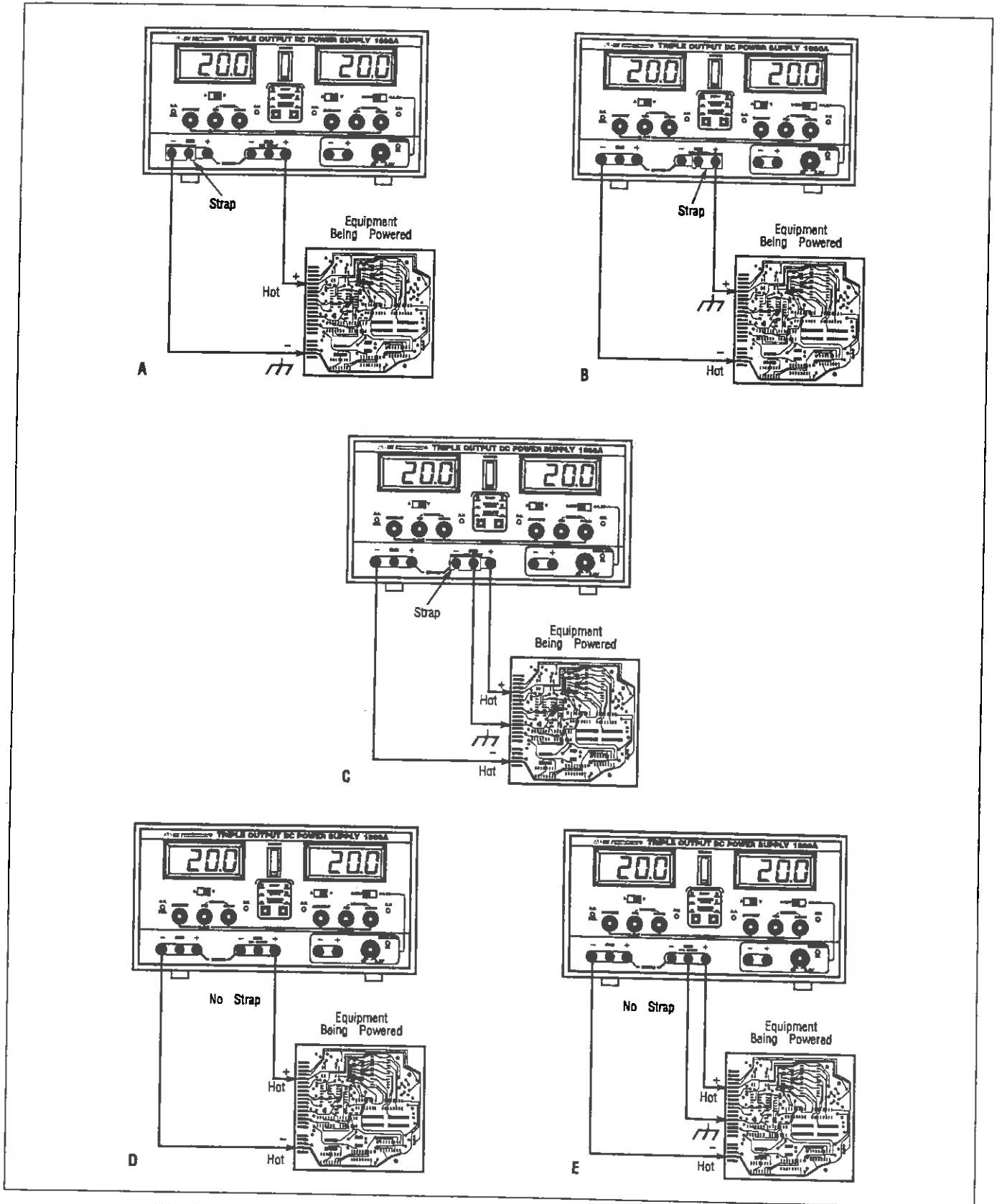

Fig 8. Series Tracking (0-to-60 V) Operation Grounding Possibilities.

OPERATING INSTRUCTIONS

and current track the **MASTER** supply output voltage and current.

1. Set the power supplies to the **TRACKING PARALLEL** mode by engaging both **TRACKING** switches.
2. Set the **0-30 V/4-6.5 V** switch to the **0-30 V** position, the **MASTER A/V** switch to the **V** (voltage metering) position, and the **SLAVE A/V** switch to the **A** (current metering) position. Output voltage will now be read from the **MASTER LED Display**. Output current is exactly double the value read from the **SLAVE LED Display** (because each supply is providing the same amount of current).
3. Because both voltage and current of the **SLAVE** supply track the **MASTER** supply, the maximum current and voltage are set using the **MASTER** controls. Using the **MASTER** supply output jacks, follow the instructions for "Setting Current Limit" (INDEPENDENT USE OF "MASTER" OR "SLAVE" SUPPLY paragraph of this section). Remember that the actual current output at the **MASTER** supply output jacks is double the reading on the **SLAVE LED Display**.
4. Adjust the output voltage to the desired level using the **MASTER VOLTAGE** controls.
5. Turn off the power supply and the equipment to be powered during hook-up.
6. Connect the positive polarity of the device being powered to the red (+) terminal of the **MASTER** power supply.
7. Connect the negative polarity of the device being powered to the black (-) terminal of the **MASTER** power supply.
8. Fig. 9 illustrates the grounding possibilities when used in the **TRACKING PARALLEL** mode.
 - a. If the negative polarity of the equipment or circuit being powered is also the chassis or common, it may be grounded to earth by strapping the black (-) terminal to the green (**GND**) terminal as shown in Fig. 9A.
 - b. Similarly, the positive polarity can be grounded by strapping the red (+) terminal to the green (**GND**) terminal as shown in Fig. 9B.
 - c. If an earth ground reference is not required, the configuration of Fig. 9C may be used. The scheme in Fig. 9C should also be used where it is not known whether the chassis is common with either the positive or negative polarity.
 - d. If the chassis or common of the equipment being powered is separate from both the positive and negative polarity power inputs, use the connection shown in Fig. 9D.
9. Observe proper polarity. If the circuit being powered is not equipped with reverse polarity protection, damage to the circuit can result from reverse polarity. Use color coded hook-up leads, such as the sets supplied with the power supply, for convenience in identifying polarity, red for (+) and black for (-).
10. Make sure that the hook-up leads offer sufficient current capability and low resistance between the power supply and the circuits being powered. The hook-up leads supplied with the power supply are rated for 3 amps. 10-amp test leads are available as an optional accessory.

4-6.5 V POWER SUPPLY OPERATION

The **4-6.5 V** supply provides a 4.0 to 6.5 V DC output with a 5 amp current capacity. The supply is ideal for use with TTL circuits.

1. Set the **0-30 V/4-6.5 V** switch to the **4-6.5 V** position and the **MASTER A/V** switch to the **V** position. This sets the **MASTER/4-6.5 V Display** to show output voltage of the **4-6.5 V** supply.
2. Using the **Voltage Level Control** to adjust the output voltage of the 4-6.5 V supply to the desired level.
3. Turn off the power supply and the equipment to be powered during hook-up.
4. Connect the positive polarity of the device being powered to the red (+) terminal of the **4-6.5 V** supply.

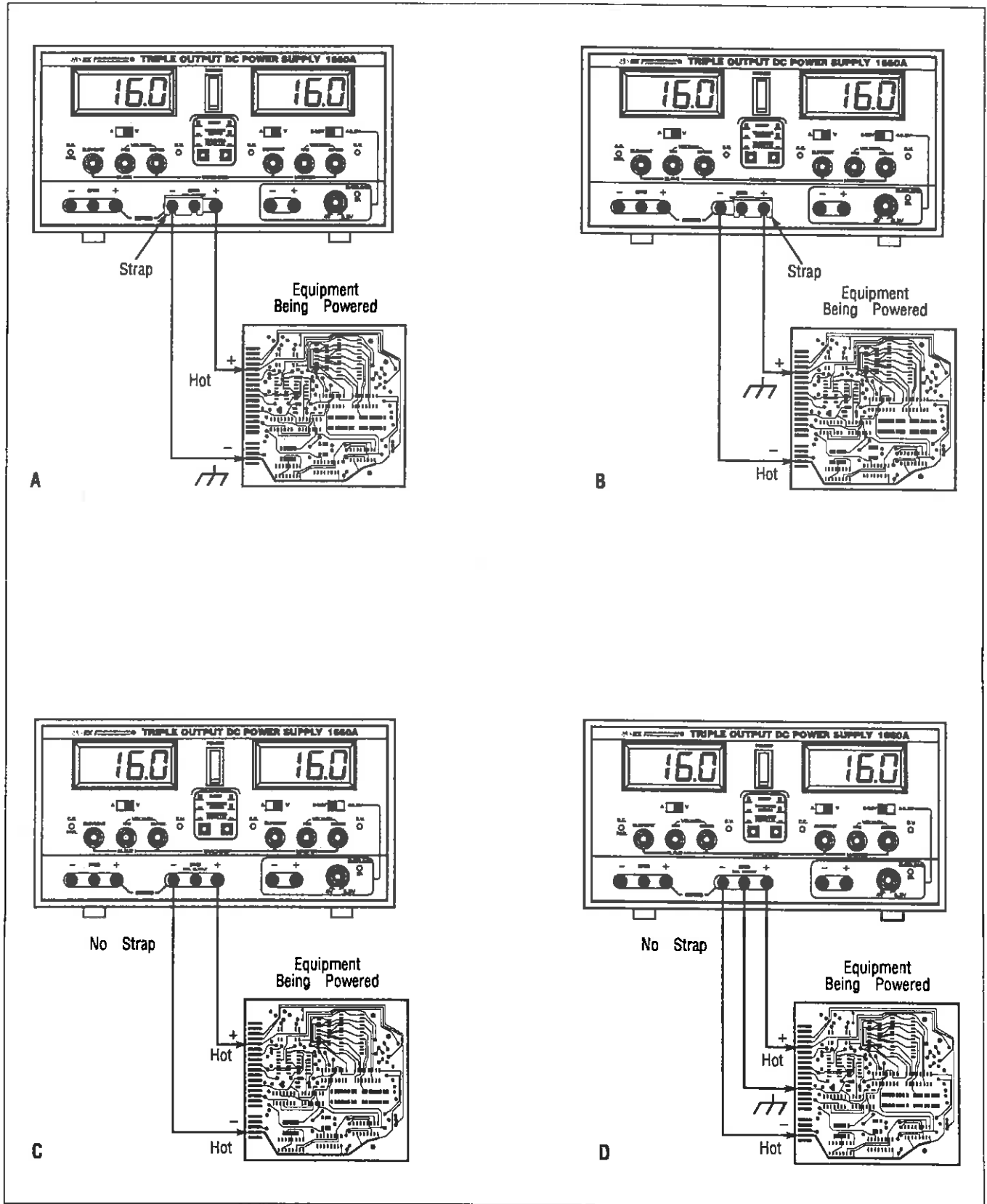

Fig. 9. Parallel Tracking Operation Grounding Possibilities.

OPERATING INSTRUCTIONS

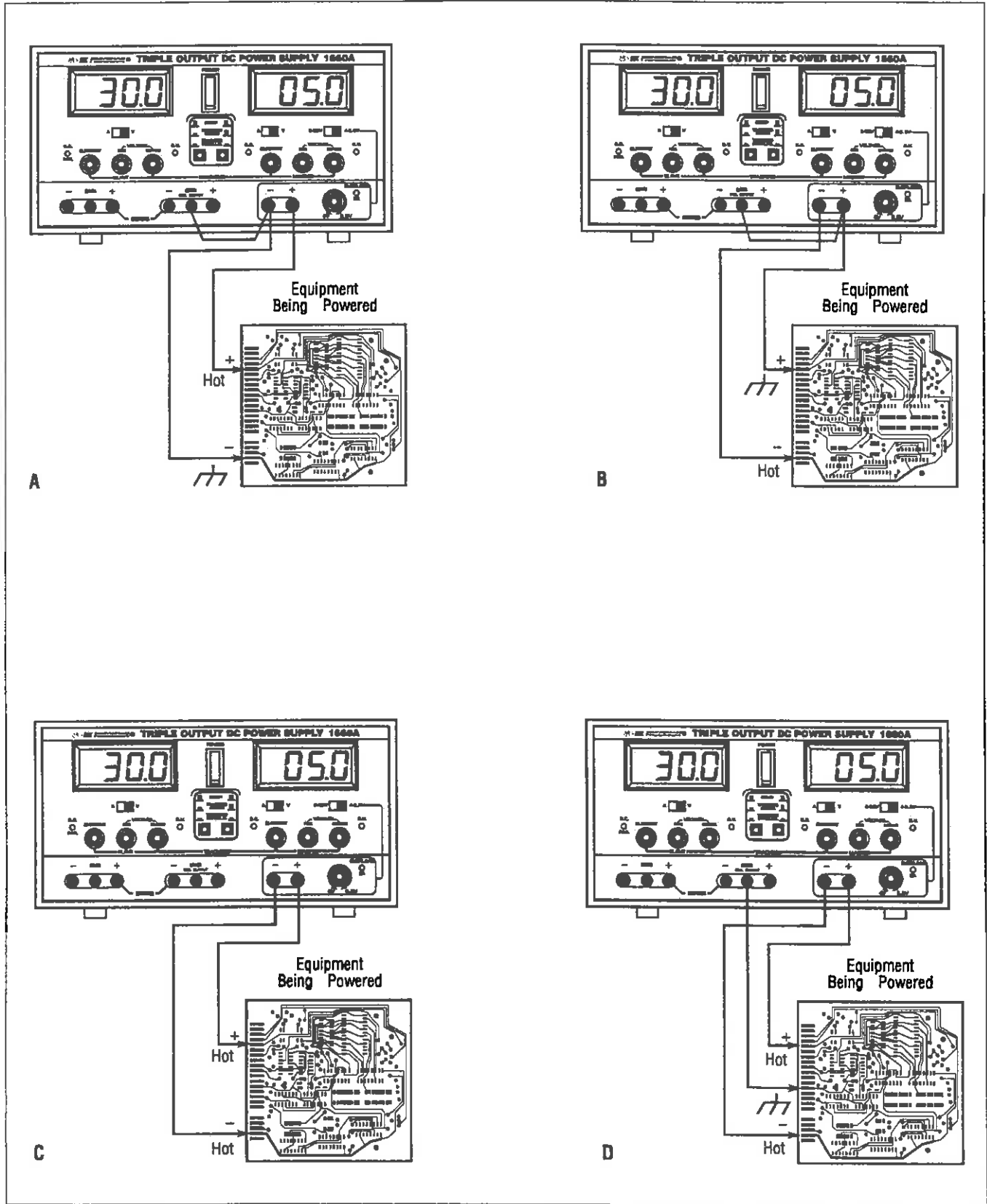

Fig. 10. Grounding Possibilities for 4-6.5 V Power Supply.

5. Connect the negative polarity of the device being powered to the black (–) terminal of the **4-6.5 V** supply.
6. Fig. 10 illustrates the grounding possibilities of the the **4-6.5 V** supply.
 - a. If the negative polarity of the equipment or circuit being powered is also the chassis or common, it may grounded to earth by connecting a jumper from the black (–) terminal to either green (**GND**) terminal as shown in Fig. 10A.
 - b. Similarly, the positive polarity can be grounded by connecting a jumper between the red (+) terminal and either green (**GND**) terminal as shown in Fig. 10B.
 - c. If an earth ground reference is not required, the configuration of Fig. 10C may be used. The scheme in Fig. 10C should also be used where it is not known whether the chassis is common with either the positive or negative polarity.
 - d. If the chassis or common of the equipment being powered is separate from both the positive and negative polarity power inputs, use the connection shown of Fig. 10D.
7. Observe proper polarity. If the circuit being powered is not equipped with reverse polarity protection, damage to the circuit can result from reverse polarity. Use color coded hook-up leads, such as the sets supplied with the power supply, for convenience in identifying polarity, red for (+) and black for (–).
8. Make sure that the hook-up leads offer sufficient current capability and low resistance between the power supply and the circuits being powered. The hook-up leads supplied with the power supply are rated for 3 amps. 10-amp hook-up leads are available as an optional accessory.
9. If the red **OVERLOAD** indicator lights, too much load has been placed on the supply. This will cause voltage and current to drop and prevent proper operation of the **4-6.5 V** supply. To correct this situation, the load on the supply must be decreased so that no more than 5 amps of current are required.

NOTE

If decreasing the load does not cause the overload indicator to turn off, the overvoltage protection circuitry has turned on. In order to return the supply to normal operation, the output voltage must be decreased (or the external voltage source must be removed) **and the power must be momentarily shut off.**

APPLICATIONS

GENERAL

The Model 1660A power supply has a very wide variety of applications in electrical and electronics servicing, engineering laboratories, manufacturing and testing facilities, schools, and home hobbying. The Master and Slave power supply outputs are fully adjustable from 0-to-30 volts and 0-to-2 amps and the 4-6.5 V supply is fully adjustable from 4-to-6.5 V with a current capability of 0-to-5 amps. This flexibility makes it suitable for most applications requiring a dc power source.

ELECTRONICS SERVICING

Most electronics troubleshooting and repair is performed on a test bench. This power supply can provide the dc power source to operate a module or circuit board on the test bench when it is removed from its parent equipment. It can be used to power portable, battery-operated equipment and check the effect of low battery voltage. It can power vehicular equipment such as tape players, auto sound systems, CB radios, etc. on the test bench. Parallel tracking supplies up to 4 amps, adequate surge current for most vehicular equipment.

Most automobiles and other vehicles use 12-volt electrical systems. Although the electrical system is normally referred to as a 12-volt system, actual battery voltage when fully charged is approximately 14 volts. The power supply may be set to 14 volts for servicing equipment from vehicles with 12-volt electrical systems. Some trucks use a 24-volt electrical system; bench testing of equipment from these systems should be performed at 28 volts.

Some servicing applications require the injection of a variable dc voltage for certain tests, such as checking the effect of AGC bias in a television receiver. This requires an isolated dc power supply, such as the Model 1660A. The equipment being tested may contain its own power supply and operate from ac power. A dc voltage may already be present in the circuit. One polarity of the power supply output is floated to an appropriate point in the circuit, such as

the emitter of a transistor. The other polarity of the power supply output is then applied to another point in the circuit, such as the base of that transistor. Varying the power supply voltage then varies the dc bias on the stage, and the effects may be noted. A series limiting resistor is often used to protect the circuits from overdissipation.

ELECTRONICS MANUFACTURING

In electronics manufacturing facilities, the power supply is often used as a dc power source while testing and adjusting modules, subassemblies, and complete units in the production and assembly area or in the quality control area. The instrument can be used in incoming inspection as a dc power source for testing purchased components and subassemblies.

This power supply is particularly well suited for manufacturing applications because of its ease of operation and its continuous duty rating. When load current or total power dissipation are among the main characteristics to be measured, the total load current and voltage are easily displayed on the LED display. The current limit can be set so that all units which do not meet the load current specification will cause the CC indicator to light, and the unit can be rejected.

ELECTRONICS DESIGN LAB

The technician or engineer working in an engineering laboratory requires a dc power supply to power breadboard and prototype circuits. This power supply is ideal because it monitors output current and voltage, limits current to protect the circuit, is adjustable over a wide range, and has excellent regulation and very low ripple.

Use of the instrument in an engineering laboratory is very similar to that described for servicing electronics equipment and modules, except that lower currents may be prevalent when powering individual circuits. The current limiting feature is very valuable in this application because it can protect unproven circuits from damage.

ELECTRONICS EDUCATION

The student in an electronics curriculum may use the power supply for powering equipment and circuits as previously described for all other applications. In addition, the power supply can be used in the classroom laboratory to conduct experiments in fundamental electronics. In learning Ohm's law, for example, the relationships of resistance, current, and voltage are easily demonstrated by the use of a power supply.

BATTERY CHARGING

The power supply can be used as a battery charger to restore the charge in rechargeable batteries such as lead-acid, nickel-cadmium, and some alkaline types. Refer to the battery manufacturer's charging specifications for proper voltage and current settings. Charging information is sometimes printed on the batteries. Battery charging, at least initially, requires the constant current mode of operation. Before connecting the power supply to the battery, preset the **VOLTAGE** controls to the fully charged terminal voltage specified by the battery manufacturer. Turn off the power supply while connecting the battery. Observe proper polarity and connect as for constant current operation. Adjust the **CURRENT** control for the maximum charging current specified by the battery manufacturer. (If the maximum charging current is greater than the power supply's maximum load current, set the **CURRENT** control to maximum). The **CC** indicator will light and the battery will charge at the preset current limit. As the battery approaches full charge, its terminal voltage will approach that of the power supply output and the charging current will taper off. The power supply may automatically switch to **CV** (constant voltage) operation. When this occurs, the power supply will continue to provide a trickle charge.

SPLIT SUPPLY

Frequently, "split power supplies" are required for amplifier and other electronic circuits. The Model 1660A is ideally suited for "split power supply" operation. This supply can be configured to provide two positive voltages with a common negative, two negative voltages with a common positive, or one positive and one negative with a common ground. In

addition, each of these configurations can be obtained with identical or differing voltages.

Two Identical Positive Voltages With a Common Negative (Refer To Fig. 11)

Some electronic equipment requires two identical positive voltages with a common negative. A good example of this would be a digital car clock where there are two +12 volt inputs and a common negative. Using both supplies in the parallel tracking mode would provide the simplest hook-up and operation. This type of "split supply" operation is obtained as follows:

1. Connect a ground strap between the **MASTER** supply's negative terminal and ground.
2. Set the desired voltage and maximum current using the **MASTER VOLTAGE** and **CURRENT** controls.
3. Turn off the power supply and the equipment to be powered during hook-up.
4. Connect the positive polarity inputs of the circuit to be powered to the positive (red) terminals of the supplies and connect the common negative input of the circuit to be powered to the **MASTER**

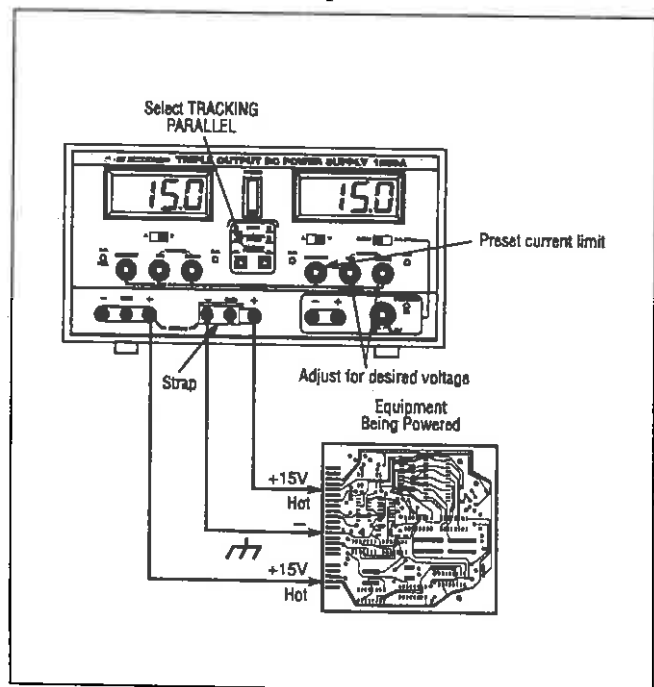

Fig. 11. Typical Hook-Up Using Two Identical Positive Voltages and a Common Negative.

supply's negative (black) or ground (green) terminal.

Two Differing Positive Voltages With a Common Negative

(Refer To Fig. 12)

Many electronic circuits require two different positive voltages with a common negative. A typical example of this would be a device that uses both TTL (+5 V) and analog (typically +15 V) circuitry. Using both supplies, two differing positive voltages with a common negative are obtained as follows:

1. Select the **INDEP**endent operating mode and set up the LED displays so that both displays monitor voltage.
2. Connect the ground straps between each supplies' negative terminal and ground.
3. Independently set the desired voltage and maximum current for the **MASTER** and **SLAVE** supplies using the **MASTER VOLTAGE** and **CURRENT** controls and the **SLAVE VOLTAGE** and **CURRENT** controls respectively.
4. Turn off the power supply and the equipment to be powered during hook-up.

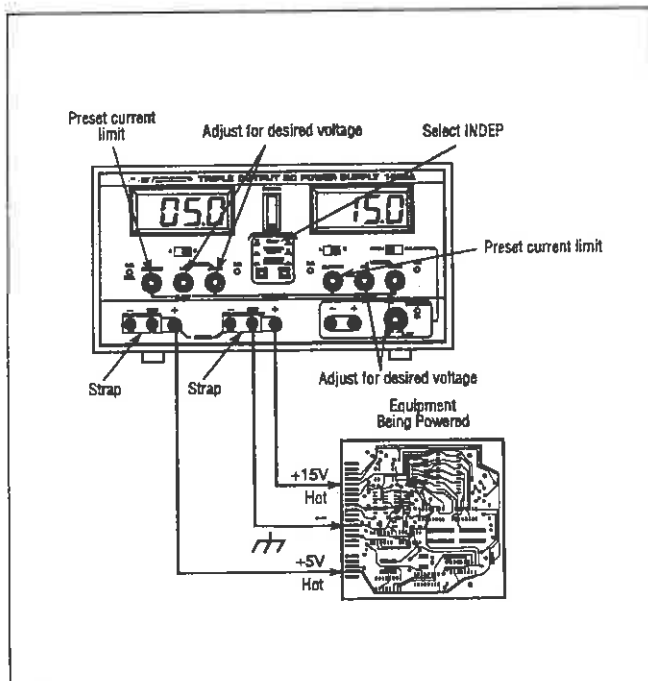

Fig. 12. Typical Hook-Up Using Two Differing Positive Voltages and a Common Negative.

5. Connect the positive polarity inputs of the circuit to be powered to the positive (red) terminal of the supply. Connect the common negative input of the circuit to be powered to either of the supply's negative (black) or ground (green) terminal.

6. If desired, set the LED displays to monitor current.

Two Identical Negative Voltages With a Common Positive

(Refer To Fig. 13)

When the same negative voltage is required at two points in the same circuit and a common positive is needed, perform the following:

1. Connect the ground strap between the positive terminal and the ground of the **MASTER** supply.
2. Set the desired voltage and maximum current using the **MASTER VOLTAGE** and **CURRENT** controls.
3. Turn off the power supply and the equipment to be powered during hook-up.
4. Connect the negative polarity inputs of the circuit to be powered to the negative (black) terminals of the supplies. Connect the common positive input of the circuit to be powered to the **MASTER** supply's positive (red) or ground (green) terminal.

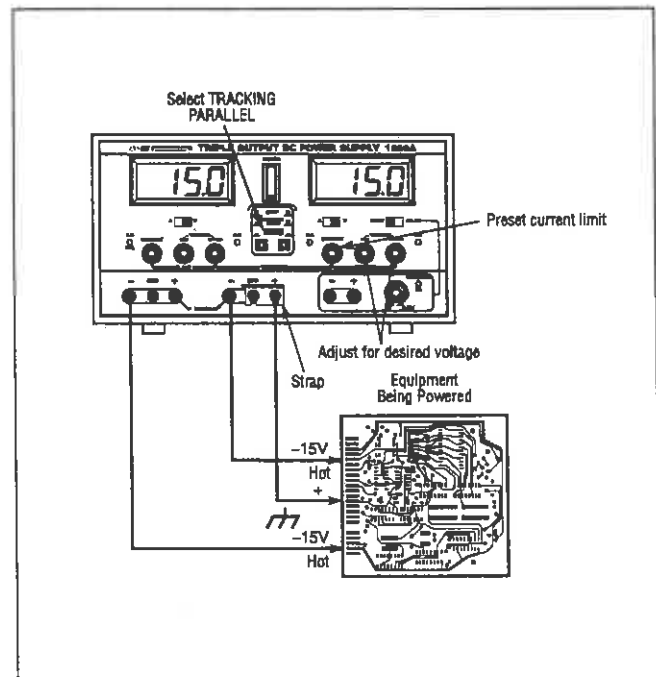

Fig. 13. Typical Hook-Up Using Two Identical Negative Voltages and a Common Positive.

**Two Differing Negative Voltages With a Positive Common
(Refer To Fig. 14)**

Using both supplies, two differing negative voltages with a common positive are obtained as follows:

1. Select the **INDEP**endent operating mode and set up the LED displays so that both displays monitor voltage.
2. Connect the ground straps between each supplies' positive terminal and ground.
3. Independently set the desired voltage and maximum current for the **MASTER** and **SLAVE** supplies using the **MASTER VOLTAGE** and **CURRENT** controls and the **SLAVE VOLTAGE** and **CURRENT** controls respectively.
4. Turn off the power supply and the equipment to be powered during hook-up.
5. Connect the negative polarity inputs of the circuit to be powered to the negative (black) terminals of the supplies. Connect the common positive input of the circuit to be powered to either supplies positive (red) or ground (green) terminal.
6. If desired, set the LED displays to monitor current.

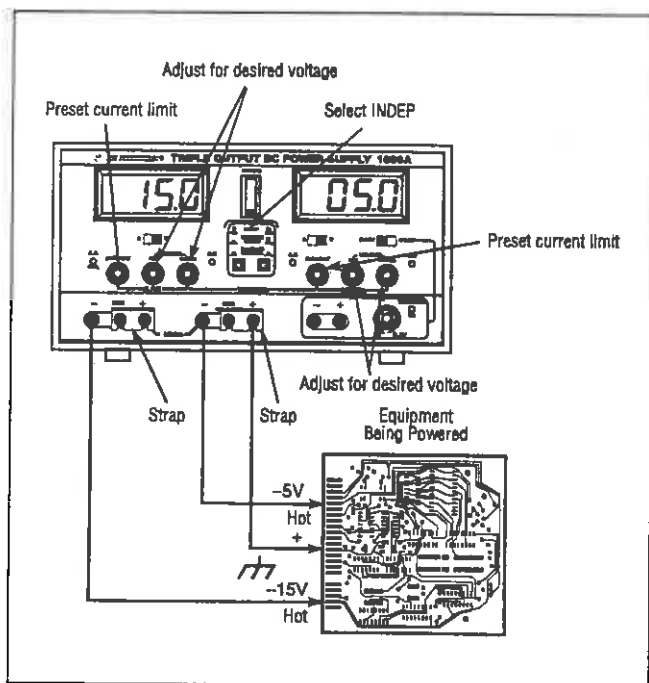

Fig. 14. Typical Hook-Up Using Two Different Negative Voltages and a Common Positive.

**Identical Positive and Negative Voltages With a Separate Common
(Refer To Fig. 15)**

Another typical "split supply" application is when a circuit uses operational amplifiers (op-amps). Typically, identical positive and negative voltages are required to power op-amp circuits. Using both supplies and the series tracking mode of operation, identical positive and negative voltages with a separate common are obtained as follows:

1. Select the **TRACKING SERIES** operating mode and set up the LED displays so that at least one of the displays monitors voltage.
2. Connect the ground strap between the ground terminal and the negative terminal of the **MASTER** supply.
3. Set the desired voltage using the **MASTER VOLTAGE** controls. Independently set the maximum current for the **MASTER** and **SLAVE** supplies using the **MASTER CURRENT** and **SLAVE CURRENT** controls respectively.
4. Turn off the power supply and the equipment to be powered during hook-up.

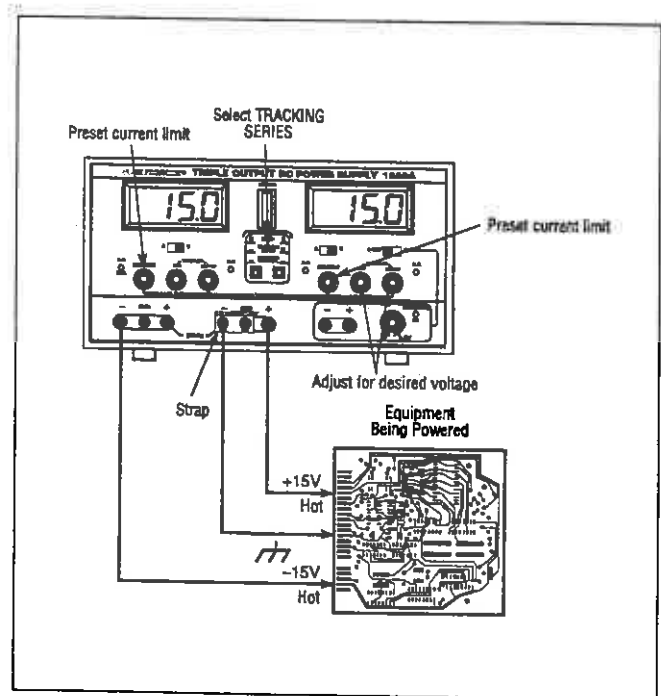

Fig. 15. Typical Hook-Up Using Identical Positive and Negative Voltages with a Separate Common.

APPLICATIONS

5. Connect the positive polarity input of the circuit to be powered to the positive (red) terminal of the **MASTER** supply and connect the negative polarity of the circuit to the negative terminal of the **SLAVE** supply. Connect the circuit ground to the ground terminal of the **MASTER** supply.
6. If desired, set one, or both of the LED displays to monitor current. Although often balanced, there can be different load current for each of the supplies in this configuration.

Differing Positive and Negative Voltages With a Separate Common (Refer To Fig. 16)

Using both supplies and the independent tracking mode of operation, different positive and negative voltages with a separate common are obtained as follows:

1. Select the **INDEP**endent operating mode and set up the LED displays to monitor voltage.
2. Connect one ground strap between the ground terminal and the negative terminal of the **MASTER** supply and the other between the ground terminal and the positive terminal of the **SLAVE** supply.
3. Set the desired voltage for each supply using the **VOLTAGE** controls. Set the maximum current using the **CURRENT** controls.
4. Turn off the power supply and the equipment to be powered during hook-up.

5. Connect the positive polarity input of the circuit to be powered to the positive (red) terminal of the **MASTER** supply and connect the negative polarity of the circuit to the negative terminal of the **SLAVE** supply. Connect the circuit ground to the ground terminal of either the **MASTER** or **SLAVE** supply.
6. If desired, set the LED displays to monitor current. The load current will usually be different for each of the supplies in this configuration.

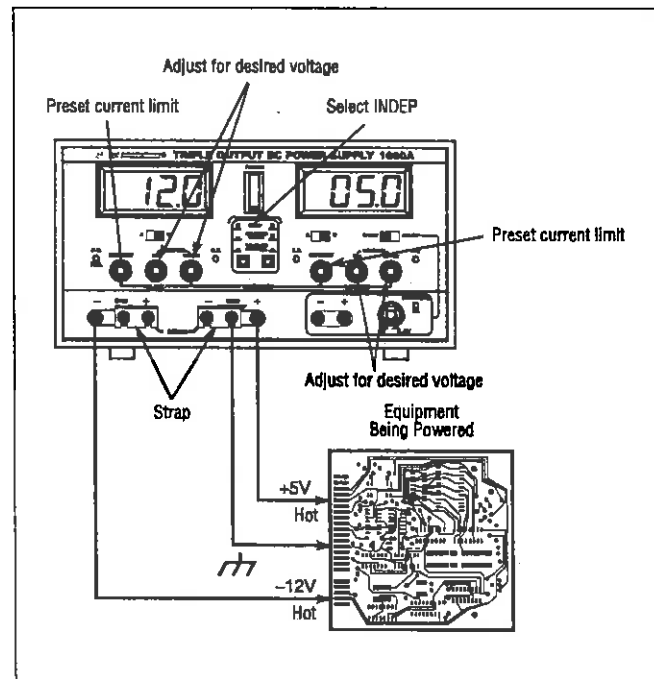

Fig. 16. Typical Hook-Up Using Differing Positive and Negative Voltages and a Separate Common.

MAINTENANCE

WARNING

The following instructions are for use by qualified personnel only. To avoid electrical shock, do not perform any servicing other than contained in the operating instructions unless you are qualified to do so.

FUSE REPLACEMENT

If the fuse blows, the switch, the LED displays, and all other indicators will not light and the power supply will not operate. The fuse should not normally open unless a problem has developed in the unit. Try to determine and correct the cause of the

blown fuse, then replace only with a fuse of the correct rating. For 110 or 120 V operation a 5 A, 250 V, fuse should be used and for 220 or 240 V operation a 2.5 A, 250 V, fuse should be used. The fuse is located on the rear panel (see Fig. 2).

LINE VOLTAGE CONVERSION

The primary winding of the power transformer is tapped to permit operation from 110, 120, 220, or 240 VAC, 50/60 Hz line voltage. Conversion from one line voltage to another is done by a simple wiring change as shown in Fig. 17.

A label on the rear panel identifies the line voltage to which the unit was factory wired.

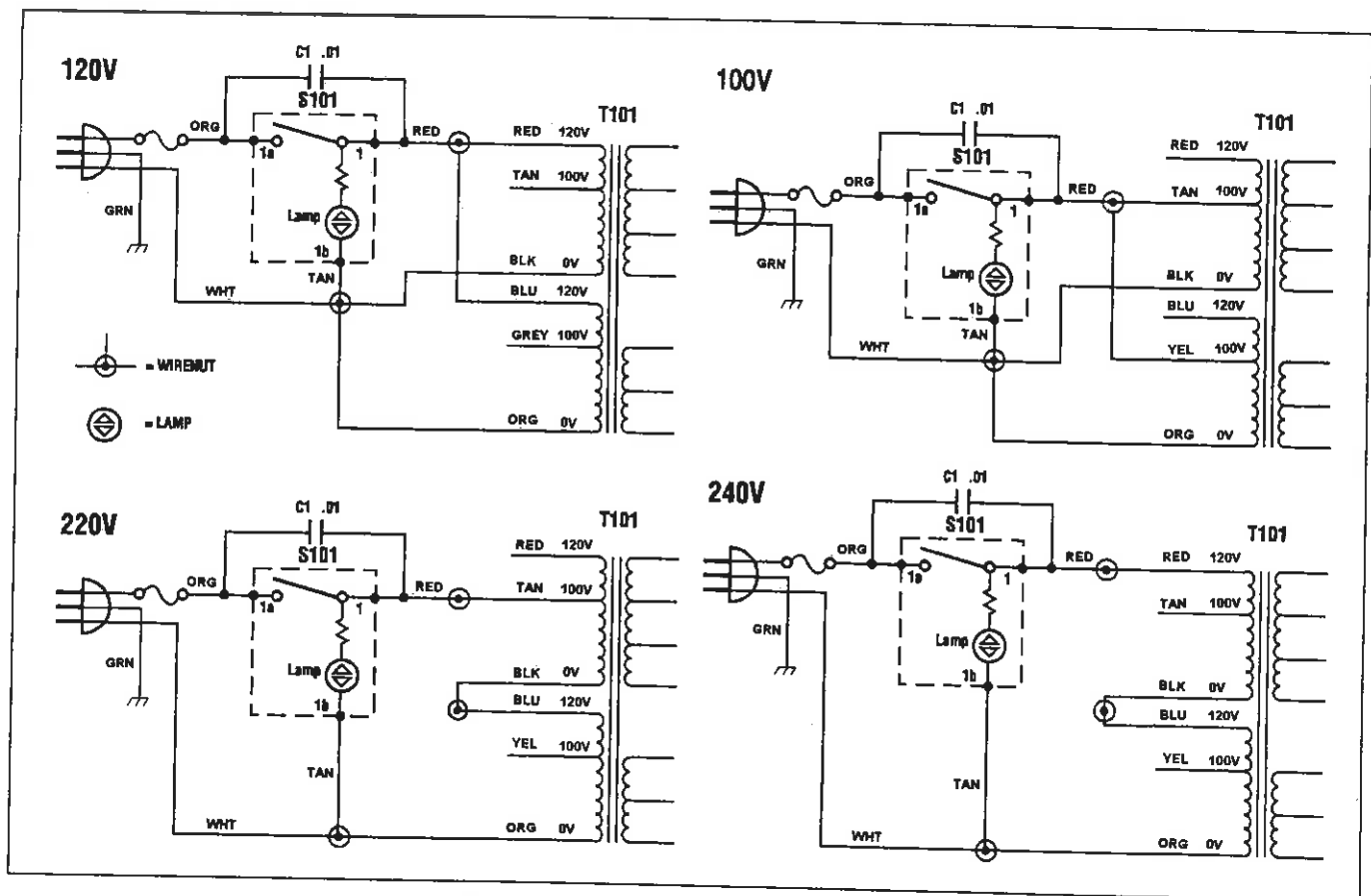

Fig. 17. Line Voltage Conversion.

MAINTENANCE

To convert to a different line voltage, perform the following procedure:

1. Make sure the power cord is unplugged.
2. Remove the case and locate the power transformer.
3. Rewire the power transformer to the desired line voltage as shown in Fig. 17. Insulate the ends of the unused transformer tap wires.
4. A change in line voltage may also require a corresponding change of fuse value. Install the correct fuse value as listed in the **FUSE REPLACEMENT** section.
5. Replace the cover.
6. Affix a label showing the correct line voltage and fuse value (if changed) for the unit after conversion. Place this label directly over the factory label.

ADJUSTMENTS

This unit was accurately adjusted at the factory before shipment. Readjustment is recommended only if repairs have been made in a circuit affecting adjustment accuracy, or if you have a reason to believe the unit is out of adjustment. However, ad-

justments should be attempted only if a 4-1/2 digit multimeter with an accuracy of $\pm 0.1\%$ dcv or better is available (**B+K Precision Model 391** or equivalent).

If readjustment is required, use the following procedure. All references to left and right are correct when facing the front of the supply. The functions of the adjustments are shown in Table 1 and their locations are shown in Fig. 18.

MASTER SUPPLY AND MASTER METERING ADJUSTMENTS

1. Connect an accurate (0.1%) external 4-1/2 digit multimeter to measure the dc voltage at the output terminals of the **MASTER SUPPLY**.
2. Disengage both **TRACKING** mode switches (both switches out) so that the power supply is in the **INDEPENDENT** operating mode.
3. Set the **MASTER VOLTAGE** controls (both **COARSE** and **FINE**) to minimum (fully counter-clockwise).
4. Adjust **SVR102 (MIN VOLT ADJ)**, if installed, on the main circuit board (located on the right side

<u>ADJUSTMENT</u>	<u>FUNCTION OF ADJUSTMENT</u>	<u>LOCATION OF ADJUSTMENT</u>
SVR101	MASTER MAX VOLT	MAIN BOARD
SVR102	MASTER MIN VOLT	MAIN
SVR103	MASTER AMPS	MAIN
SVR201	SLAVE MAX VOLT	MAIN
SVR202	SLAVE MIN VOLT	MAIN
SVR203	SLAVE AMPS	MAIN
SVR301	SERIES MIN VOLT	MAIN
SVR302	PARALLEL AMPS	MAIN
SVR303	SERIES TRACKING ERROR	CONTROL
SVR401	4V SET	MAIN
SVR402	4V A METER & A LIMIT	MAIN
SVR501	MASTER V METER	MASTER PANEL
SVR502	4-6.5V V METER	MASTER PANEL
SVR503	MASTER A METER	MASTER PANEL
SVR601	SLAVE V METER	SLAVE PANEL
SVR602	SLAVE A METER	SLAVE PANEL

Table 1. Function of Calibration Adjustments.

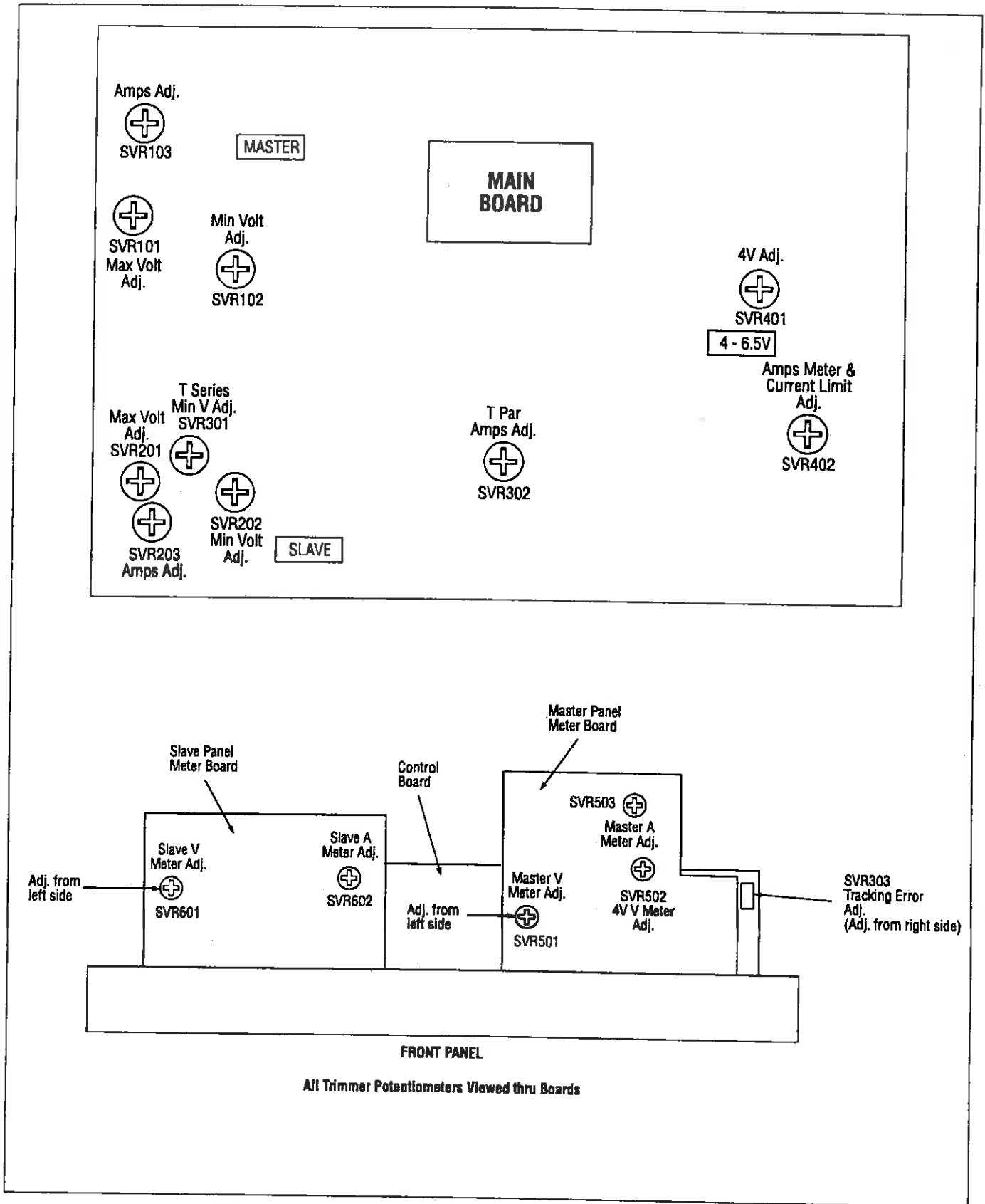

Fig. 18. Location of Adjustments (Main Circuit Boards).

MAINTENANCE

- of the supply) for a reading of $-10\text{mV} \pm 10\text{mV}$ on the multimeter.
5. Set the **MASTER VOLTAGE** controls (both **COARSE** and **FINE**) to maximum (fully clockwise).
 6. Adjust **SVR101 (MAX VOLTAGE ADJ)** on the main circuit board (located on the right side of the supply) for a reading as close to **31.50** volts (on the multimeter) as possible.
 7. Set the **0-30V/4-6.5V** switch to the **0-30V** position and the **MASTER A/V** switch to the **V** position.
 8. Adjust **SVR501 (MASTER V METER ADJ)** on the master panel meter board (located on the right side of the supply behind the **MASTER LED Display**) for a reading of **31.50** volts on the **MASTER LED Display**.
 9. Set the **MASTER A/V** switch to the **A** position.
 10. Connect the external multimeter across the **MASTER SUPPLY** output terminals to read the output current (so that the meter causes a short circuit across the terminals) and adjust the **MASTER CURRENT** control so that **2.00** amps is read on the multimeter.
 11. Adjust **SVR503 (MASTER A METER ADJ)** so that the **MASTER LED Display** also reads **2.00** amps.
 12. Rotate the **MASTER CURRENT** control fully clockwise (maximum).
 13. Adjust **SVR103 (AMPS ADJ)** on the main board (located on the right side of the supply) to obtain an output current of **2.05** amps (read on the **MASTER LED Display**).

4-6.5V SUPPLY AND 4-6.5V METERING ADJUSTMENTS

1. Set the **0-30V/4-6.5V** switch to the **4-6.5V** position and the **MASTER A/V** switch to the **V** position.
2. Connect an accurate ($\pm 0.1\%$) external 4-1/2 digit multimeter across the output terminals of the **4-6.5V SUPPLY** to read output voltage and adjust the **4-6.5V** front panel voltage level control to minimum (4V, fully counterclockwise).
3. Adjust **SVR401 (4V ADJ)** located on the main board for a reading of **4.00** volts on the external multimeter.
4. Adjust **SVR502 (4V V METER ADJ)** located on the master panel board behind the **MASTER LED Display** so that the **MASTER/4-6.5V LED Display** reads **4.0** volts.
5. Set the **MASTER A/V** switch to the **A** position.
6. Turn **SVR402 (AMPS METER AND CURRENT LIMIT ADJ)** located on the main board fully clockwise.
7. Connect a 1Ω load (rated at 30W or more) across the output terminals of the **4-6.5V SUPPLY** and connect the multimeter to read the output current.
8. Adjust the **4-6.5V** voltage level control to obtain an output of **5.30** amps (read on the multimeter).
9. Adjust **SVR402 (AMPS METER AND CURRENT LIMIT ADJ)** so that the **MASTER/4-6.5V LED Display** also reads **5.30** amps.

SLAVE SUPPLY AND METERING ADJUSTMENTS

1. Connect an accurate ($\pm 0.1\%$) external 4-1/2 digit multimeter to measure the dc voltage at the output terminals of the **SLAVE SUPPLY**.
2. Disengage both **TRACKING** mode switches (both switches out) so that the power supply is in the **INDEPENDENT** operating mode.
3. Set the **SLAVE VOLTAGE** controls (both **COARSE** and **FINE**) to minimum (fully counterclockwise).
4. Adjust **SVR202 (MIN VOLT ADJ)**, if installed, on the main board (located on the right side of the supply) for a reading of $-10\text{mV} \pm 10\text{mV}$ on the multimeter.
5. Set the **SLAVE VOLTAGE** controls (both **COARSE** and **FINE**) to maximum (fully clockwise).
6. Adjust **SVR201 (MAX VOLT ADJ)** on the main board for as close to **31.50** volts (on the multimeter) as possible.

7. Set the **SLAVE A/V** switch to the **V** position.
8. Adjust **SVR601 (SLAVE V METER ADJ)** on the slave panel board (located on the left side of the supply behind the **SLAVE LED Display**) for a reading of **31.50** volts on the **SLAVE LED Display**.
9. Set the **SLAVE A/V** switch to the **A** position.
10. Connect the external multimeter across the **SLAVE SUPPLY** output terminals to read the output current (so that the meter causes a short circuit across the terminals) and adjust the **SLAVE CURRENT** control so that **2.00** amps is read on the multimeter.
11. Adjust **SVR602 (SLAVE A METER ADJ)** so that the **SLAVE LED Display** also reads **2.00** amps.
12. Rotate the **SLAVE CURRENT** control fully clockwise (maximum).
13. Adjust **SVR203 (AMPS ADJ)** on the main board to obtain a reading of **2.05** amps on the **SLAVE LED Display**.

SLAVE SERIES TRACKING ADJUSTMENT

1. Set the supply to the **TRACKING SERIES** mode by engaging the left **TRACKING** switch and releasing the right **TRACKING** switch.
2. Set the **SLAVE CURRENT** control to midrange.
3. Set the **MASTER VOLTAGE** controls (both **COARSE** and **FINE**) to minimum (fully counterclockwise).
4. Connect the multimeter to the **MASTER SUPPLY** outputs and measure the voltage.
5. Disconnect the multimeter from the **MASTER SUPPLY** outputs and connect it across the **SLAVE SUPPLY** outputs.
6. Adjust **SVR301 (T SER MIN V ADJ)** on the main board to obtain the exact same reading for the **SLAVE SUPPLY** output as was present at the **MASTER SUPPLY** output (e.g., if the minimum **MASTER SUPPLY** output voltage is **-10.31mV**, adjust **SVR301** to obtain an output voltage as close to **-10.31mV** at the **SLAVE SUPPLY** as possible.

7. Set the **MASTER VOLTAGE** controls (both **COARSE** and **FINE**) to maximum (fully clockwise).
8. Connect the multimeter to the **MASTER SUPPLY** outputs and measure the voltage.
9. Disconnect the multimeter from the **MASTER SUPPLY** outputs and connect it to the **SLAVE SUPPLY** outputs.
10. Adjust **SVR303 (TRACKING ERROR ADJ)** (located on the right edge of the control board on the right side of the supply) until the voltage read from the multimeter is the same as it was across the **MASTER SUPPLY** output terminals. Return the multimeter to the **MASTER SUPPLY** output terminals and verify that the output voltage is identical. If not, repeat this step.

TRACKING PARALLEL CURRENT ADJUSTMENT

1. Set the supply to the **TRACKING PARALLEL** mode by engaging both the left and right **TRACKING** switches.
2. Set the **0-30V/4-6.5V** switch to the **0-30V** position, the **MASTER A/V** switch to the **A** position, and the **SLAVE A/V** switch to the **A** position.
3. Connect the external multimeter across the **MASTER SUPPLY** output terminals to read the output current (so that the meter causes a short circuit across the terminals) and adjust the **MASTER CURRENT** control so that **2.00** amps is read on the **MASTER LED Display**.
4. Adjust **SVR302 (T PARAMPS ADJ)** on the main board so that the external multimeter reads **4.00** amps and the **SLAVE SUPPLY Display** reads **2.00** amps.

INSTRUMENT REPAIR SERVICE

Because of the specialized skills and test equipment required for instrument repair and calibration, many customers prefer to rely upon **B+K Precision** for this service. We maintain a network of **B+K Precision** authorized service agencies for this purpose. To use this service, even if the oscilloscope is no longer under warranty, follow the instructions given in the **WARRANTY SERVICE INSTRUCTION** portion of this manual. There is a nominal charge for instruments out of warranty.

WARRANTY SERVICE INSTRUCTIONS

(For U.S.A. and its Overseas Territories)

1. Refer to the MAINTENANCE section of your **B+K Precision** instruction manual for adjustments that may be applicable.
2. If the above-mentioned does not correct the problem you are experiencing with your unit, pack it securely (preferably in the original carton or double-packed).
3. Enclose a letter describing the problem and include your name and address.
4. Enclose proof of purchase date; that is, a dated copy of the sales receipt.
5. Deliver to, or ship PREPAID (UPS preferred in U.S.A.) to the nearest **B+K Precision** authorized service agency (see list enclosed with unit).

If your list of authorized **B+K Precision** service agencies has been misplaced, contact your distributor for the name of your nearest service agency, or write to:

B+K Precision, Maxtec International Corp.
Factory Service Operations
6470 West Cortland Street
Chicago, Illinois 60635
Tel (312) 889-1448
Fax (312) 794-9740

Also use this address for technical inquiries and replacement parts orders.

LIMITED ONE-YEAR WARRANTY

MAXTEC INTERNATIONAL CORPORATION warrants to the original purchaser that its **B + K Precision** product, and the component parts thereof, will be free from defects in workmanship and materials for a period of one year from the date of purchase.

MAXTEC will, without charge, repair or replace, at its option, defective product or component parts upon delivery to an authorized **B + K Precision** service contractor or the factory service department, accompanied by proof of the purchase date in the form of a sales receipt.

To obtain warranty coverage in the U.S.A., this product must be registered by completing and mailing the enclosed warranty registration card to **B + K Precision**, 6470 West Cortland Street, Chicago, Illinois 60635 within fifteen (15) days from the date of purchase.

Exclusions: This warranty does not apply in the event of misuse or abuse of the product or as a result of unauthorized alterations or repairs. It is void if the serial number is altered, defaced or removed.

MAXTEC shall not be liable for any consequential damages, including without limitation damages resulting from loss of use. Some states do not allow limitation of incidental or consequential damages, so the above limitation or exclusion may not apply to you.

This warranty gives you specific rights and you may also have other rights which vary from state to state.

For your convenience we suggest you contact your **B+K Precision** distributor, who may be authorized to make repairs or can refer you to the nearest service contractor. If warranty service cannot be obtained locally, please send the unit to **B+K Precision** Service Department, 6470 West Cortland Street, Chicago, Illinois 60635, properly packaged to avoid damage in shipment.

B+K Precision Test Instruments warrants products sold only in the U.S.A. and its overseas territories. In other countries, each distributor warrants the **B+K Precision** products which it sells.

NOTES

NOTES

NOTES