

**OPERATION AND SERVICE MANUAL**

**MODEL 7620 HypotULTRA®III**  
**MODEL 7650 HypotULTRA®III**  
Electrical Safety Compliance Analyzer

**AC/DC HIPOT WITH INSULATION RESISTANCE TESTER, CONTINUITY TESTER,  
AND RS-232 INTERFACE on 7650**  
**AC HIPOT WITH CONTINUITY TESTER AND RS-232 INTERFACE on 7620**

**SERIAL NUMBER**

--	--	--	--	--	--	--	--

**Models**  
**7620, 7650**

*Item 38363 Ver 2.07*

© Associated Research, Inc. 2005  
13860 West Laurel Drive  
Lake Forest, Illinois, 60045-4546  
U.S.A.  
Printed June 28, 2005



## DECLARATION OF CONFORMITY

**Manufacturer:** Associated Research, Inc.  
**Address:** 13860 W. Laurel Dr.  
Lake Forest, IL 60045 USA  
**Product Name:** Electrical Safety Compliance  
Analyzer  
**Model Number:** 7620/7650

### Conforms to the following Standards:

**Safety:** EN 61010-1:2001  
EN 61010-2-031:1994

**EMC:** EN 55011:1998 Group I Class A  
EN 31623:1997+A1:1998  
(EN 61000-4-2:1995, EN 61000-4-3:1996,  
EN 61000-4-4:1995, EN 61000-4-5:1995,  
EN 61000-4-6:1996, EN 61000-4-8:1993,  
EN 61000-4-11:1994)

### Supplementary Information

*The product herewith complies with the requirements of the Low Voltage Directive 73/23/EEC as amended by 93/68/EEC and the EMC Directive 89/336/EEC as amended by 92/31/EEC.*

*The CE marking has been affixed on the device according to article 10 of the EMC Directive 8/336/EEC.*

*The technical file and other documentation are on file with Associated Research, Inc.*

Joseph Guerriero  
Vice President / General Manager

Associated Research, Inc.  
Lake Forest, Illinois USA  
July 28, 2003

## TABLE OF CONTENTS

<b>1. Introduction.....</b>	<b>1</b>
1.1. Warranty.....	1
1.2. Safety Symbols.....	2
1.2.1. Product Marking Symbols.....	2
1.2.2. Caution and Warning Symbols.....	2
1.3. Glossary of Terms.....	3
1.4. Safety.....	4
1.4.1. Service and Maintenance.....	4
1.4.2. Test Station.....	5
1.4.3. Test Operator.....	6
1.4.4. Instrument Connections.....	6
1.4.5. Device Under Test.....	7
1.4.6. Key Safety Points to Remember.....	7
1.5. Introduction to Product Safety Testing.....	8
1.5.1. The Importance of Safety Testing.....	8
1.6. The Different Types of Safety Tests.....	8
1.6.1. Principles and Uses of Dielectric Withstand Testing.....	8
1.6.2. Insulation Resistance Test.....	11
1.6.3. Ground Bond Test.....	11
1.6.4. Run Test.....	12
1.6.5. Line Leakage Test.....	12
1.7. Key Features and Benefits.....	14
<b>2. Getting Started.....</b>	<b>17</b>
2.1. Unpacking and Inspection.....	17
2.1.1. Packaging.....	17
2.1.2. Contents of Carton.....	17
2.1.3. Returning the Instrument for Service or Calibration.....	17
2.2. Installation.....	18
2.2.1. Work Area.....	18
2.2.2. Power Requirements.....	18
2.2.3. Basic Connections.....	18
2.2.4. Environmental Conditions.....	19
<b>3. Specifications and Controls.....</b>	<b>20</b>
3.1. Specifications.....	20
3.2. Instrument Controls.....	26
3.2.1. Front Panel Controls.....	26
3.2.2. Rear Panel Controls.....	28
3.3. Quickstart.....	30

www.valuetronics.com

<b>4. Programming Instructions.....</b>	<b>34</b>
4.1. Setup System .....	34
4.1.1. Setup System Soft keys .....	35
4.1.2. System Parameters .....	36
4.1.3. Cal Alert (Calibration Alert) .....	41
4.2. Setup Tests Menu .....	45
4.2.1. Selecting a Memory .....	45
4.2.2. Naming a Memory .....	45
4.2.3. Selecting a Step .....	46
4.2.4. Reviewing Test Parameters .....	46
4.2.5. Editing Test Parameters .....	46
4.2.6. Prompt .....	48
4.3. Test Parameters .....	49
4.3.1. Description of Test Parameters .....	49
4.3.2. AC Withstand .....	51
4.3.3. DC Withstand .....	52
4.3.4. Insulation Resistance .....	53
4.3.5. Continuity .....	55
4.3.6. Default Parameters .....	56
4.4. Memory, Step, and Default System Parameter Initialization.....	57
<b>5. Operating Instructions .....</b>	<b>58</b>
5.1. Instrument Connections .....	58
5.1.1. Adapter Box Connections.....	58
5.2. Perform Tests Screen .....	59
5.2.1. Connected Step Indicator .....	59
5.2.2. Single Step .....	60
5.2.3. Fail Stop .....	60
5.2.4. Results .....	61
5.3. Perform Tests Metering .....	61
5.3.1. Real Current Display .....	61
5.4. Performing a Test .....	62
5.4.1. Manual Voltage Adjustment .....	62
5.5. Displayed Messages .....	63
5.5.1. Test Status Messages .....	63
<b>6. Instrument Verification .....</b>	<b>66</b>
6.1. Verification Initialization .....	66
6.2. Verification Menu .....	66
6.2.1. Continuity Verification .....	67
6.2.2. AC Hipot Verification .....	68
6.2.3. DC Hipot Verification .....	69
6.2.4. IR Verification .....	70



<b>7. Remote Control .....</b>	<b>71</b>
7.1. Signal Outputs on Remote I/O .....	71
7.2. Signal Inputs of Remote I/O and Programmed Test Files.....	72
<b>8. Bus Remote Interface GPIB / RS-232 .....</b>	<b>75</b>
8.1. A Brief History of IEEE-488.....	75
8.2. GPIB Messages .....	75
8.3. Functions .....	75
8.4. Signals and Lines .....	75
8.5. GPIB Connector .....	76
8.6. GPIB Address.....	77
8.7. Interface Functions.....	77
8.8. RS-232 Interface.....	78
8.9. HypotULTRA III, GPIB / RS-232 Interface Command List .....	78
8.9.1. Test Execution Commands .....	79
8.9.2. File Editing Commands .....	79
8.9.3. Test Parameter Editing Commands and Companion Queries .....	81
8.9.4. System Parameter Editing Commands and Companion Queries.....	83
8.9.5. Query Commands.....	84
8.9.6. IEEE 488.2 Common Commands .....	87
8.9.7. Status Reporting .....	89
8.9.8. GPIB Service Request.....	90
8.10. Example of Communicating Over the GPIB Bus .....	90
8.11. Non Volatile Memory .....	91
<b>9. Options .....</b>	<b>92</b>
<b>10. Calibration Procedure.....</b>	<b>101</b>
10.1. Warranty Requirements.....	101
10.2. Calibration Initialization .....	102
10.3. Selecting Specific Calibration points.....	102
10.4. Calibration of Parameters .....	102
10.4.1. Calibration of AC Hipot Voltage .....	103
10.4.2. Calibration of DC Hipot Voltage .....	103
10.4.3. Calibration of IR DC Voltage .....	104
10.4.4. Calibration of 30mA AC Total Current Range .....	104
10.4.5. Calibration of 3.5mA AC Total Current Range .....	105
10.4.6. Calibration of 200W/30mA AC Real Current Range.....	105
10.4.7. Calibration of 20W/30mA AC Real Current Range.....	106
10.4.8. Calibration of 20W/3.5mA AC Real Current Range.....	106
10.4.9. Calibration of 2W/3.500mA AC Real Current Range.....	107
10.4.10. Calibration of 10mA DC Current Range.....	107
10.4.11. Calibration of 3.500mA DC Current Range.....	108

CC BY-NC-SA



10.4.12. Calibration of 350uA DC Current Range.....	108
10.4.13. Calibration of 999.99MΩ IR Range.....	109
10.4.14. Calibration of 9999.9MΩ IR Range.....	109
10.4.15. Calibration of 50000MΩ IR Range.....	110
10.4.16. Calibration of Continuity 20Ω.....	110
10.4.17. Calibration of Continuity 200Ω.....	111
10.4.18. Calibration of Continuity 2000Ω.....	111
<b>11. Replacement Parts List .....</b>	<b>113</b>
<b>12. Schematic Index .....</b>	<b>115</b>

**Index is located at the back of the Manual.**

1  
2  
3  
4  
5  
6  
7  
8  
9  
10  
11  
12  
13  
14  
15  
16  
17  
18  
19  
20  
21  
22  
23  
24  
25  
26  
27  
28  
29  
30  
31  
32  
33  
34  
35  
36  
37  
38  
39  
40  
41  
42  
43  
44  
45  
46  
47  
48  
49  
50  
51  
52  
53  
54  
55  
56  
57  
58  
59  
60  
61  
62  
63  
64  
65  
66  
67  
68  
69  
70  
71  
72  
73  
74  
75  
76  
77  
78  
79  
80  
81  
82  
83  
84  
85  
86  
87  
88  
89  
90  
91  
92  
93  
94  
95  
96  
97  
98  
99  
100

1  
2  
3  
4  
5  
6  
7  
8  
9  
10  
11  
12  
13  
14  
15  
16  
17  
18  
19  
20  
21  
22  
23  
24  
25  
26  
27  
28  
29  
30  
31  
32  
33  
34  
35  
36  
37  
38  
39  
40  
41  
42  
43  
44  
45  
46  
47  
48  
49  
50  
51  
52  
53  
54  
55  
56  
57  
58  
59  
60  
61  
62  
63  
64  
65  
66  
67  
68  
69  
70  
71  
72  
73  
74  
75  
76  
77  
78  
79  
80  
81  
82  
83  
84  
85  
86  
87  
88  
89  
90  
91  
92  
93  
94  
95  
96  
97  
98  
99  
100

## 1. Introduction

### 1.1. Warranty Policies

Associated Research, Inc., certifies that the instrument listed in this manual meets or exceeds published manufacturing specifications. This instrument was calibrated using standards that are traceable to the National Institute of Standards and Technology (NIST).

Your new instrument is warranted to be free from defects in workmanship and material for a period of (1) year from date of shipment. You must complete the on-line registration at [www.asresearch.com/register](http://www.asresearch.com/register) or call 1-800-858-TEST ext. 210 to register over the phone

#### 5-Year Program

AR recommends that your instrument be calibrated on a twelve-month cycle. Instruments purchased and used in North America only, may have their warranty extended in one year increments to a maximum of **(5) years** provided they are returned to AR at least **annually** for calibration and inspection. The annual calibration and inspection must be performed annually every year following receipt of instrument. Any instrument not calibrated and inspected annually will not be eligible for extended warranty status. This extended warranty is non-transferable and is offered only to the original purchaser. A return material authorization (RMA) must be obtained from AR before returning this instrument for warranty service. Please contact our Customer Support Center at 1-800-858-TEST (8378) to obtain an RMA number. It is important that the instrument is packed in its original container for safe transport. If the original container is not available please contact our customer support center for proper instructions on packaging. Damages sustained as a result of improper packaging will not be honored. Transportation costs for the return of the instrument for warranty service must be prepaid by the customer. AR will assume the return freight costs when returning the instrument to the customer. The return method will be at the discretion of Associated Research.

#### 3-Year Program

A 3-Year warranty is also available for instruments purchased and used in North America. All costs for this warranty are paid with the initial purchase and include warranty coverage, annual calibration and standard ground return freight for three years. However, unlike our 5-year program annual calibration and inspection by Associated Research is not required.

Except as provided herein, Associated Research makes no warranties to the purchaser of this instrument and all other warranties, express or implied (including, without limitation, merchantability or fitness for a particular purpose) are hereby excluded, disclaimed and waived.

Any non-authorized modifications, tampering or physical damage will void your warranty. Elimination of any connections in the earth grounding system or bypassing any safety systems will void this warranty. This warranty does not cover batteries or accessories not of Associated Research manufacture. Parts used must be parts that are recommended by AR as an acceptable specified part. Use of non-authorized parts in the repair of this instrument will void the warranty.

## 1.2. Safety Symbols

### 1.2.1. Product Marking Symbols

 Product will be marked with this symbol when it is necessary to refer to the operation and service manual in order to prevent injury or equipment damage.

 Product will be marked with this symbol when hazardous voltages may be present.

 Product will be marked with this symbol at connections that require earth grounding.

### 1.2.2. Caution and Warning Symbols

**WARNING** Calls attention to a procedure, practice, or condition that could possibly cause bodily injury or death.

**CAUTION** Calls attention to a procedure, practice, or condition that could possibly cause damage to equipment or permanent loss of data

### 1.3. Glossary of Terms

(As used in this manual)

**Alternating Current, AC:** Current that reverses direction on a regular basis, commonly in the U.S.A. 60 per second, in other countries 50 times per second.

**Breakdown:** The failure of insulation to effectively prevent the flow of current sometimes evidenced by arcing. If voltage is gradually raised, breakdown will begin suddenly at a certain voltage level. Current flow is not directly proportional to voltage. Once breakdown current has flown, especially for a period of time, the next gradual application of voltage will often show breakdown beginning at a lower voltage than initially.

**Conductive:** Having a volume resistivity of no more than  $10^3$  ohm-cm or a surface resistivity of no more than  $10^5$  ohms per square.

**Conductor:** A solid or liquid material which has the ability to let current pass through it, and which has a volume resistivity of no more than  $10^3$  ohm-cm.

**Current:** The movement of electrons through a conductor. Current is measured in amperes, milliamperes, microamperes, nanoamperes, or picoamperes. Symbol = I

**Dielectric:** An insulating material that is positioned between two conductive materials in such a way that a charge or voltage may appear across the two conductive materials.

**Direct Current, DC:** Current that flows in one direction only. The source of direct current is said to be polarized and has one terminal that is always at a higher potential than the other.

**Hipot Tester:** Common term for dielectric-withstand test equipment.

**Hypot®:** Registered trademark of Associated Research, Inc., for its dielectric-withstand test equipment.

**Insulation:** Gas, liquid or solid material which has a volume resistivity of at least  $10^{12}$  ohm-cm and is used for the purpose of resisting current flow between conductors.

**Insulation Resistance Tester:** An instrument or a function of an instrument capable of measuring resistance's in excess of 200 megohms. Usually employs a higher voltage power supply than used in ohmmeters measuring up to 200 megohms.

**Leakage:** AC or DC current flow through insulation and over its surfaces, and AC current flow through a capacitance. Current flow is directly proportional to voltage. The insulation and/or capacitance are thought of as a constant impedance, unless breakdown occurs.

**Resistance:** That property of a substance that impedes current and results in the dissipation of power, in the form of heat. The practical unit of resistance is the *ohm*. Symbol = R

**Trip Point:** A minimum or maximum parameter set point that will cause an indication of unacceptable performance during a run test.

**Voltage:** Electrical pressure, the force which causes current through an electrical conductor.  
Symbol = V

## 1.4. Safety

This product and its related documentation must be reviewed for familiarization with safety markings and instructions before operation.

This product is a Safety Class I instrument (provided with a protective earth terminal). Before applying power, verify that the instrument is set to the correct line voltage (110 or 220) and the correct fuse is installed.

### **WARNING**

A Hipot produces voltages and currents that can cause **harmful or fatal electric shock**. To prevent accidental injury or death, these safety procedures must be strictly observed when handling and using the test instrument.

### 1.4.1. Service and Maintenance

#### User Service

To prevent electric shock do not remove the instrument cover. There are no user serviceable parts inside. Routine maintenance or cleaning of internal parts is not necessary. Avoid the use of cleaning agents or chemicals on the instrument; some chemicals may damage plastic parts or lettering. Any external cleaning should be done with a clean dry or slightly damp cloth. Schematics, when provided, are for reference only. Any replacement cables and high voltage components should be acquired directly from Associated Research, Inc. Refer servicing to an Associated Research, Inc. authorized service center.

ASSOCIATED RESEARCH, INC.  
13860 WEST LAUREL DRIVE  
LAKE FOREST, IL 60045-4546 U.S.A.

PHONE: 1 (847) 367-4077  
1 (800) 858-TEST (8378)  
FAX: 1 (847) 367-4080  
E-MAIL : [info@asresearch.com](mailto:info@asresearch.com)  
[www.asresearch.com](http://www.asresearch.com)

#### Service Interval

The instrument, its power cord, test leads, and accessories must be returned at least once a year to an Associated Research authorized service center for calibration and inspection of safety related components. Associated Research will not be held liable for injuries suffered if the instrument is not properly maintained and safety checked annually.

#### User Modifications

Unauthorized user modifications will void your warranty. Associated Research will not be responsible for any injuries sustained due to unauthorized equipment modifications or use of parts not specified by Associated Research. Instruments returned to Associated Research with unsafe modifications will be returned to their original operating condition at the customer's expense.

#### 1.4.2. Test Station

##### Location

Select an area away from the main stream of activity that employees do not walk through in performing their normal duties. If this is not practical because of production line flow, then the area should be roped off and marked for **HIGH VOLTAGE TESTING**. No employees other than the test operators should be allowed inside.

If benches are placed back-to-back, be especially careful about the use of the bench opposite the test station. Signs should be posted: "**DANGER - HIGH VOLTAGE TEST IN PROGRESS - UNAUTHORIZED PERSONNEL KEEP AWAY.**"

##### Work Area

Perform the tests on a non-conducting table or workbench, if possible. If you cannot avoid using a conductive surface, be certain that it is connected to a good earth ground and the high voltage connection is insulated from the grounded surface.

There should not be any metal in the work area between the operator and the location where products being tested will be positioned. Any other metal in the work area should be connected to a good ground, never left "floating".

Position the tester so the operator does not have to reach over the product under test to activate or adjust the tester. If the product or component being tested is small, it may be possible to construct guards or an enclosure around the device to be tested. Construct the guards of a non-conducting material such as clear acrylic, so that the item being tested is within the guards or enclosure during the test. If possible, the guards or enclosure should also contain safety switches that will not allow the tester to operate unless the guards are in place or the enclosure closed.

Keep the area clean and uncluttered. All test equipment and test leads not necessary for the test should be removed from the test bench and put away. It should be apparent to both the operator and to any observers, the product that is being tested and the product that is waiting to be tested, or has already been tested.

Do not perform Hipot tests in a combustible atmosphere or in any area where combustible materials are present.

##### Power

Dielectric Voltage-Withstand Test Equipment must be connected to a good ground. Be certain that the power wiring to the test bench is properly polarized and that the proper low resistance bonding to ground is in place.

Power to the test station should be arranged so that it can be shut off by one prominently marked switch located at the entrance to the test area. In case of an emergency, anyone can cut off the power before entering the test area to offer assistance.

### 1.4.3. Test Operator

#### Qualifications

This instrument generates voltages and currents that can cause **harmful or fatal electric shock** and must only be operated by a skilled worker trained in its use.

The operator should understand the electrical fundamentals of voltage, current, and resistance. They should recognize that the test instrument is a variable high-voltage power supply with the return circuit directly connected to earth ground; therefore, current from the high-voltage output will flow through any available ground path.

#### Rules

Operators should be thoroughly trained to follow all of the aforementioned rules, in addition to any other applicable safety rules and procedures. Defeating any safety system should be considered a serious offense with severe penalties such as removal from the Hipot testing job. Allowing unauthorized personnel in the area during a test should also be dealt with as a serious offense.

#### Dress

Operators should not wear jewelry that could accidentally complete a circuit.

#### Medical Restrictions

Personnel with heart ailments or devices such as pacemakers should be informed that the voltages and currents generated by the instrument are very dangerous. If contacted it may cause heart-related problems that a person of good health may not experience. Please have the test operator consult their physician for recommendations.

### 1.4.4. Instrument Connections

**WARNING** Never perform a Hipot test on energized circuitry or equipment.

 The instrument is equipped with a safety ground connection, be sure that this is connected to a good earth ground.

Always connect the return lead first, regardless of whether the item under test is a sample of insulating material, a component tested with the high voltage test lead, or a cord-connected device with a two or three prong plug. The return lead should be connected first for any type of hipot testing.

Plug in the high voltage test lead only when it is being used. Handle its clip only by the insulator---**never touch the clip directly**. Be certain that the operator has control over any remote test switches connected to the Hipot. Double-check the return and high voltage connections from the Hipot and the Line to be certain that they are proper and secure.



#### 1.4.5. Device Under Test

**WARNING** Never touch the Device Under Test (DUT) or anything connected to it while high voltage is being applied by the Hipot.

When testing with DC, always discharge the capacitance of the item under test and anything the high voltage may have contacted--such as test fixtures--before handling it or disconnecting the test leads.

**HOT STICK** probes can be used to discharge any capacitance in the device under test as a further safety precaution. A hot stick is a non-conducting rod about two feet long with a metal probe at the end that is connected to a wire. To discharge the device under test, two hot sticks are required. First, connect both probe wires to a good earth ground. Then touch one probe tip to the same place that the return lead was connected. While holding the first probe in place, touch the second probe tip to the same place where the high voltage lead was connected.

#### 1.4.6. Key Safety Points to Remember

- Keep unqualified and unauthorized personnel away from the test area.
- Arrange the test station in a safe and orderly manner.
- Never touch the product or connections during a test.
- In case of any problem, turn off the high voltage first.
- Properly discharge any item tested with DC before touching connections.

## 1.5. Introduction to Product Safety Testing

### 1.5.1. The Importance of Safety Testing

Product Safety Tests are specified during the design and development stages of a product as well as in the production of the products to insure that it meets basic safety requirements. These tests are designed to verify the safety of the electrical products in that they do not jeopardize the safety of the people, domestic animals, and property of anyone who may come in contact with these products. In an era of soaring liability costs, original manufacturers of electrical and electronic products must make sure every item is as safe as possible. All products must be designed and built to prevent electric shock, even when users abuse the equipment or by-pass built in safety features.

To meet recognized safety standards, one common test is the "dielectric voltage-withstand test". Safety agencies which require compliance safety testing at both the initial product design stage and for routine production line testing include: Underwriters Laboratories, Inc. (UL), the Canadian Standards Association (CSA), the International Electrotechnical Commission (IEC), the British Standards Institution (BSI), the Association of German Electrical Engineers (VDE) and (TÜV), the Japanese Standards Association (JSI). These same agencies may also require that an insulation resistance test and high current ground bond test be performed.

## 1.6. The Different Types of Safety Tests

### 1.6.1. Dielectric Withstand Test

The principle behind a dielectric voltage - withstand test is simple. If a product will function when exposed to extremely adverse conditions, it can be assumed that the product will function in normal operating circumstances.

#### Common Applications of the Dielectric Withstand Test:

- Design (performance) testing: Determining design adequacy to meet service conditions.
- Production Line testing: Detecting defects in material or workmanship during processing.
- Acceptance testing: Proving minimum insulation requirements of purchased parts.
- Repair Service testing: Determine reliability and safety of equipment repairs.

The specific technique used to apply the dielectric voltage - withstand test to each product is different. During a dielectric voltage - withstand test, an electrical device is exposed to a voltage significantly higher than it normally encounters, for a specified duration of time.

During the test, all current flow from the high voltage output to the return is measured. If, during the time the component is tested, the current flow remains within specified limits, the device is assumed safe under normal conditions. The basic product design and use of the insulating material will protect the user against electrical shock.

The equipment used for this test, a dielectric-withstand tester, is often called a "Hipot" (for high potential tester). The "rule of thumb" for testing is to subject the product to twice its normal operating voltage, plus 1,000 volts.

However, specific products may be tested at much higher voltages than 2X operating voltages + 1,000 volts. For example, a product designed to operate in the range between 100 to 240 volts can be tested between 1,000 to 4,000 volts or higher. Most "double insulated" products are tested at voltages much higher than the "rule of thumb".

Testing during development and prototype stages is more stringent than production run tests because the basic design of the product is being evaluated. Design tests usually are performed on only a few samples of the product. Production tests are performed on every item as it comes off the production line.

The Hipot tester must also maintain an output voltage between 100% and 120% of specification. The output voltage of the Hipot must have a sinusoidal waveform with a frequency between 40 to 70 Hz and has a peak waveform value that is not less than 1.3 and not more than 1.5 times the root-mean-square value.

#### **Types of Failures only detectable with a Hipot test**

- Weak Insulating Materials
- Pinholes in Insulation
- Inadequate Spacing of Components
- Pinched Insulation

#### **Dielectric Withstand Test; AC versus DC**

Please check with the Compliance Agency you are working with to see which of the two types of voltages you are authorized to use. In some cases, a Compliance Agency will allow either AC or DC testing to be done. However, in other cases the Compliance Agency only allows for an AC test. If you are unsure which specification you must comply with please contact our CUSTOMER SUPPORT GROUP at 1-800-858-TEST (8378).

Many safety agency specifications allow either AC or DC voltages to be used during the Hipot test. When this is the case, the manufacturer must make the decision on which type of voltage to utilize. In order to do this it is important to understand the advantages and the disadvantages of both AC and DC testing.

#### **AC testing characteristics**

Most items that are Hipot tested have some amount of distributed capacitance. An AC voltage cannot charge this capacitance so it continually reads the reactive current that flows when AC is applied to a capacitive load.

### **AC testing advantages**

AC testing is generally much more accepted by safety agencies than DC testing. The main reason for this is that most items being Hipot tested will operate on AC voltages. AC Hipot testing offers the advantage of stressing the insulation alternately in both polarities, which more closely simulates stresses the product will see in real use.

Since AC testing cannot charge a capacitive load, the current reading remains consistent from initial application of the voltage to the end of the test. Therefore, there is no need to gradually bring up the voltage since there is no stabilization required to monitor the current reading. This means that unless the product is sensitive to a sudden application of voltage the operator can immediately apply full voltage and read current without any wait time.

Another advantage of AC testing is that since AC voltage cannot charge a load there is no need to discharge the item under test after the test.

### **AC testing disadvantages**

One of the disadvantages of AC testing occurs when testing capacitive products. Again, since AC cannot charge the item under test, reactive current is constantly flowing. In many cases, the reactive component of the current can be much greater than the real component due to actual leakage. This can make it very difficult to detect products that have excessively high leakage current.

Another disadvantage of AC testing is that the Hipot has to have the capability of supplying reactive and leakage current continuously. This may require a current output that is actually much higher than is really required to monitor leakage current and in most cases is usually much higher than would be needed with DC testing. This can present increased safety risks as operators are exposed to higher currents.

### **DC testing characteristics**

During DC Hipot testing, the item under test is charged. The same test item capacitance that causes reactive current in AC testing, results in initial charging current which exponentially drops to zero in DC testing.

### **DC testing advantages**

Once the item under test is fully charged, the only current flowing is true leakage current. This allows a DC Hipot tester to clearly display only the true leakage of the product under test.

Another advantage to DC testing is that the charging current only needs to be applied momentarily. This means that the output power requirements of the DC Hipot tester can typically be much less than what would be required in an AC tester to test the same product.

### **DC testing disadvantages**

Unless the item being tested has virtually no capacitance, it is necessary to raise the voltage gradually from zero to the full test voltage. The more capacitive the item the more slowly the voltage must be raised. This is important since most DC Hipots have failure shut off circuitry

which will indicate failure almost immediately if the total current reaches the leakage threshold during the initial charging of the product under test.

Since a DC Hipot does charge the item under test, it becomes necessary to discharge the item after the test.

DC testing unlike AC testing only charges the insulation in one polarity. This becomes a concern when testing products that will actually be used at AC voltages. This is an important reason that some safety agencies do not accept DC testing as an alternative to AC.

When performing AC Hipot tests the product under test is actually tested with peak voltages that the Hipot meter does not display. This is not the case with DC testing since a sinewave is not generated when testing with direct current. In order to compensate for this most safety agencies require that the equivalent DC test be performed at higher voltages than the AC test. The multiplying factor is somewhat inconsistent between agencies that can cause confusion concerning exactly what equivalent DC test voltage is appropriate.

#### **1.6.2. Insulation Resistance Test**

Some dielectric analyzers today come with a built in insulation resistance tester. Typically, the IR function provides test voltages from 500 to 1,000 volts DC and resistance ranges from kilohms to gigaohms. This function allows manufacturers to comply with special compliance regulations. BABT, TÜV and VDE are agencies that may under certain conditions, require an IR test on the product before a Hipot test is performed. This typically is not a production line test but a performance design test.

The insulation resistance test is very similar to the Hipot test. Instead of the go/no go indication that you get with a Hipot test the IR test gives you an insulation value usually in Megohms. Typically, the higher the insulation resistance value, the better the condition of the insulation. The connections to perform the IR test are the same as the Hipot test. The measured value represents the equivalent resistance of all the insulation that exists between the two points and any component resistance that might also be connected between the two points.

Although the IR test can be a predictor of insulation condition it does not replace the need to perform a dielectric withstand test.

#### **1.6.3. Ground Bond Test**

The Ground Bonding test determines whether the safety ground circuit of the product under test can adequately handle fault current if the product should ever become defective. A low impedance ground system is critical in ensuring that in case of a product failure, a circuit breaker on the input line will act quickly to protect the user from any serious electrical shock.

International compliance agencies such as CSA, IEC, TÜV, VDE, BABT and others, have requirements calling out this test. This test should not be confused with low current continuity tests that are also commonly called out in some safety agency specifications. A low current test merely indicates that there is a safety ground connection. It does not completely test the

integrity of that connection.

Compliance agency requirements vary on how different products are to be tested. Most specifications call for test currents of between 10 and 30 amps. Test voltages at these currents are typically required to be less than 12 volts. Maximum allowable resistance readings of the safety ground circuit are normally between 100 and 200 milliohms.

If you are testing a product that is terminated in a three-prong plug, you are required to perform a continuity or ground bond test on the ground conductor to the chassis or dead metal of the product.

#### **1.6.4. Run Test**

All manufacturers of a product that runs on line power normally need to run the DUT (Device Under Test) after final safety testing so that they can verify the functionality of their products. In addition to running the DUT to test its basic functionality, many customers also require some basic test data to be recorded while the DUT is powered up. A Run Test System allows the product to be powered up immediately after the safety tests are completed with a single connection to the DUT. Measurements that are commonly made while the DUT is running can include Amperage, Voltage, Watts and Power Factor.

#### **1.6.5. Line Leakage Test**

The Line Leakage test is one of many product safety tests that are normally specified for electrical products by safety testing agencies such as Underwriters Laboratories (UL) and the International Electrotechnical Committee (IEC). The line leakage specifications vary as well as the method in which the measurements are taken depending upon the application or function of a product and the standard to which the product is being tested.

Current Leakage or Line Leakage tests are general terms that actually describe three different types of tests. These tests are Earth Leakage Current, Enclosure Leakage Current, and Applied Part Leakage Current. The main differences in these tests are in the placement of the probe for the measuring device. The Earth Leakage Current is the leakage current that flows through the ground conductor in the line cord back to earth. The Enclosure Leakage Current is the current that flows from any enclosure part through a person back to ground if it were contacted by a person. The Applied Part Leakage Current or Patient Lead Leakage Current is any leakage that flows from an applied part, between applied parts or into an applied part. The Applied Part Leakage Current test is required only for medical equipment. All of these tests are used to determine if products can be safely operated or handled without posing a shock hazard to the user.

Line Leakage Testers provide the capability of meeting the line leakage test specified in the following standards; UL 544, IEC 950, UL 1950, IEC 601-1, UL 2601, UL 1563, UL 3101, IEC 1010 and others. The Line Leakage test, is a test which measures the leakage current of a product, through a circuit that is designed to simulate the impedance of the human body. The simulation circuit is called the Measuring Device (MD). The instrument has five different MD circuits, selectable through the menu, which are representative circuits designed to simulate the impedance of the human body under different conditions. The impedance of the human body

will vary depending upon point of contact, the surface area of the contact and the path the current flows. For these reasons, the specifications of the Measuring Devices are different depending upon the type of test being performed as well as the maximum allowable leakage current. Leakage current measurements are performed on products under normal conditions and single fault conditions as well as reversed polarity. This simulates possible problems, which could occur if the product under test is faulted or misused while the product is operating under high line conditions (110% of the highest input voltage rating of the product).

Line Leakage tests are normally specified as "Type Tests" or "Design Tests" which are performed during the development of the product. This helps verify that the design is safe but it does not guarantee the safety of the products being produced on the production line. The only way to be sure you are shipping safe products is to test each product at the end of the production line. The user may perform a Leakage Current test along with other common safety test such as Dielectric Withstand, Insulation Resistance, and Ground Bond on the production line with a single connection to the device under test.

**IF YOU SHOULD HAVE ANY QUESTIONS RELATING TO THE OPERATION OF  
YOUR INSTRUMENT CALL 1-800-858-TEST(8378) IN THE U.S.A.**

### 1.7. Key Features and Benefits: HypotULTRA III

<ul style="list-style-type: none"> <li>▪ <b>A complete all-in-one system includes AC Hipot, DC Hipot, Insulation Resistance and Ground Continuity tests in a 2U single 19 inch rack mount cabinet</b></li> </ul>	<p>HypotULTRA III combines four of the most common electrical safety tests required by safety agencies (AC Hipot, DC Hipot, IR test, Ground Continuity test) into a single instrument that takes up less rack space and enables a single DUT connection.</p>
<ul style="list-style-type: none"> <li>▪ <b>Enhanced graphic LCD display with analog bar graph for monitoring test results</b></li> </ul>	<p>This provides the operator with complete test setup and results in an easy-to-use interface. Analog bar graph can be used to monitor test results versus limit settings. The graphic display makes testing safer, easier, and more reliable than ever before.</p>
<ul style="list-style-type: none"> <li>▪ <b>Built-in CAL-ALERT™ function</b></li> </ul>	<p>This feature automatically alerts the user when the instrument is due for re-calibration. This eliminates the need for manual tracking of calibration dates.</p>
<ul style="list-style-type: none"> <li>▪ <b>Two Continuity test modes</b></li> </ul>	<p>The user can select whether to perform a low current continuity test simultaneously with the Hipot test, or use the separate continuity test mode to perform an independent continuity test. In this mode, the range is adjustable from 0.01 to 10 ohms. In addition, point-to-point continuity test can be run through the optional built-in scanner.</p>
<ul style="list-style-type: none"> <li>▪ <b>Exclusive SmartGFI™ function</b></li> </ul>	<p>The SmartGFI (patent pending) provides maximum operator protection to the user. If the circuit detects excessive leakage to ground it shuts down the high voltage in less than 1 millisecond. SmartGFI is automatically activated if the DUT is not grounded. The operator does not need to make the decision whether to activate the SmartGFI.</p>
<ul style="list-style-type: none"> <li>▪ <b>Optional printer port</b></li> </ul>	<p>This option allows direct connection of HypotULTRA III to a printer. The user can select between several different print modes and all printouts are date stamped. This is a real benefit for those requiring hard copies of test data.</p>
<ul style="list-style-type: none"> <li>▪ <b>Built-in Security settings</b></li> </ul>	<p>This allows the instrument to be setup to allow for different levels of access to the instruments setup programs. Users can setup passwords for restricting access to certain parts of the menu.</p>



<ul style="list-style-type: none"> <li>▪ <b>Storage of up to 50 setups with 30 steps per setup</b></li> </ul>	<p>A real benefit for manufacturers that test different products. Each setup can store up to 30 steps, which can be configured to perform any of the safety tests. Each setup can be stored and named any combination of alphanumeric characters so it can be easily identified for recall.</p>
<ul style="list-style-type: none"> <li>▪ <b>Real Current measurement</b></li> </ul>	<p>HypotULTRA III allows for simultaneous monitoring of Real and Total current in AC Hipot mode. This allows the user to monitor total and real current on a single screen.</p>
<ul style="list-style-type: none"> <li>▪ <b>Exclusive prompt and hold function</b></li> </ul>	<p>HypotULTRA III allows users to setup prompts in the test cycle so that the test can be paused. During the pause, a user-configured message is displayed instructing the test operator on the action they need to perform before continuing with the test. This is a very convenient feature for applications where test leads need to be moved or when DUT switches need to be activated as part of the test cycle.</p>
<ul style="list-style-type: none"> <li>▪ <b>Exclusive CHARGE LO and RAMP HI testing features allow for more effective DC Hipot testing</b></li> </ul>	<p>The RAMP HI feature allows the user to set a higher trip rate during the ramp to allow for quick charging of the product without nuisance tripping thereby increasing throughput when testing with DC. The CHARGE LO provides the user with the capability to ensure that the device under test is connected correctly.</p>
<ul style="list-style-type: none"> <li>▪ <b>Line and Load regulation</b></li> </ul>	<p>Maintains the output voltage to within 1% of setting even if the load or the line voltage varies. This ensures that the test results remain consistent and within safety agency requirements.</p>
<ul style="list-style-type: none"> <li>▪ <b>PLC remote inputs &amp; outputs</b></li> </ul>	<p>This allows the instruments to be remotely monitored and set up completely through simple PLC control. Recall of up to 10 different setups is possible through these remotes.</p>
<ul style="list-style-type: none"> <li>▪ <b>Up to 30mA of current is available in AC Hipot mode and 10 mA in DC Hipot mode with resolutions of 1 microamps in AC and 0.1 microamps in DC</b></li> </ul>	<p>This makes HypotULTRA III a true Hipot tester with enough output current to test even highly capacitive loads while allowing it to be versatile enough to monitor leakage current of items with very low leakage measurement requirements.</p>

<ul style="list-style-type: none"> <li>▪ <b>Digitally controlled arc detection system</b></li> </ul>	<p>Allows the operator to select whether low-level arcs should be detected and provides the operator with the ability to digitally select and program multiple sensitivity levels.</p>
<ul style="list-style-type: none"> <li>▪ <b>Electronic ramping (up and down)</b></li> </ul>	<p>Provides a gradual and timed method to increase or decrease output voltage to the DUT, minimizing any damage from quick high voltage changes to sensitive DUT's.</p>
<ul style="list-style-type: none"> <li>▪ <b>Built in VERI-CHEK™ self verification system</b></li> </ul>	<p>Some safety agencies require that the Hipot tester be checked and verified at various intervals. VERI-CHEK is a menu driven process by which the instruments failure detectors are proven to be functioning properly, "Verifying" the functionality of the electrical safety tester and connected accessories.</p>
<ul style="list-style-type: none"> <li>▪ <b>Extended IR measurement range</b></li> </ul>	<p>The Insulation Resistance measurement range of the HypotULTRA III allows for measurements up to 50 Gigohms.</p>
<ul style="list-style-type: none"> <li>▪ <b>Remote Interlock</b></li> </ul>	<p>The remote interlock utilizes a set of closed contacts to enable the instruments output. The system employs a fail-safe interlock, if the interlock is open, the output of the instrument is disabled. This input can be wired to a protective device to prevent activation of high voltage unless a safe test condition is detected.</p>

## 2. Getting Started

### Introduction

This section contains information for the unpacking, inspection, preparation for use and storage of your Associated Research, Inc., product.

### 2.1. Unpacking and Inspection

#### 2.1.1. Packaging

Your instrument was shipped in a custom foam insulated container that complies with ASTM D4169-92a Assurance Level II Distribution Cycle 13 Performance Test Sequence

If the shipping carton is damaged, inspect the contents for visible damage such as dents, scratches, or broken display. If the instrument is damaged, notify the carrier and Associated Research's customer support department. Please save the shipping carton and packing material for the carrier's inspection. Our customer support department will assist you in the repair or replacement of your instrument. Please do not return your product without first notifying us and receiving an RMA (return material authorization) number. To receive an RMA number, please contact our customer support department at (1-800-858-8378).

- Please retain all of the original packaging materials.

#### 2.1.2. Contents of the Carton

Inside the carton should be the following:

Description	AR Part Number
HypotULTRA III Instrument	7650 or 7620
High Voltage Cable	04040A-08
Return Cable	02100A-13 (Qty.2)
Fuse	38388
Line Cord*	33189 Standard
Adapter Box*	36544 Standard
2U Rack Mount Handle	37563 (Qty 2)
2U Rack Mount Bracket	37564 (Qty 2)
Screw M4 x 12mm FHMS	38549 (Qty 4) For Rack Mount Handle

\*The Adapter Box and Line Cord listed are American. Other combinations of Line Cord and Adapter Box are available upon request.

#### 2.1.3. Returning the Instrument

When it is necessary to return the instrument for servicing or calibration, repackage the instrument in its original container, please include all accessories and test leads. Indicate the nature of the problem or type of service needed. Also, please mark the container "FRAGILE" to insure proper handling. Upon receipt, your instrument will be issued an AR service number. Please refer to this number in all correspondence.

If you do not have the original packaging materials, please follow these guidelines:

- Wrap the instrument in a bubble pack or similar foam. Enclose the same information as above.

- Use a strong double-wall container that is made for shipping instrumentation. 350 lb. test material is adequate.
- Use a layer of shock-absorbing material 70 to 100 mm (3 to 4 inch) thick around all sides of the instrument. Protect the control panel with cardboard.
- Seal the container securely.
- Mark the container "FRAGILE" to insure proper handling.
- Please refer in all correspondence to your AR service number.

## 2.2. Installation

### 2.2.1. Work Area

**WARNING** Locate a suitable testing area and be sure you have read all safety instructions for the operation of the instrument and suggestions on the test area set-up in the Safety section. Make sure the work area you choose has a three-prong grounded outlet. Be sure the outlet has been tested for proper wiring before connecting the instrument to it.

### 2.2.2. Power Requirements

This instrument requires a power source of 115 volts AC  $\pm$  10%, 50/60 Hz single phase or 230 volts AC  $\pm$  10%, 50/60 Hz single phase. For operation at 115 and 230 Volts AC, use a 4 A, 250VAC slow-blow fuse.

### 2.2.3. Basic Connections

#### Power Cable

**WARNING** Before connecting power to this instrument, the protective ground (Earth) terminals of this instrument must be connected to the protective conductor of the line (mains) power cord. The main plug shall only be inserted in a socket outlet (receptacle) provided with a protective ground (earth) contact. This protective ground (earth) **must not be defeated** by the use of an extension cord without a protective conductor (grounding).

The instrument is shipped with a three-wire power cable. When the cable is connected to an appropriate AC power source, the cable will connect the chassis to earth ground. The type of power cable shipped with each instrument depends on the country of destination.

**CAUTION** The output power supplies of this instrument are referenced directly to earth ground. Any conductor that completes a path between the high voltage and earth ground will form a completed circuit.

### **Return Connection**

When the instrument Return is grounded, any internal and external stray leakage will be monitored due to currents that flow from High Voltage to earth ground (such as from HV to the chassis of the instrument). This current is inherent and will cause errors when trying to monitor very low leakage currents in the microampere range.

It is important to note that grounding the return lead will disable the Smart GFI function. Smart GFI allows the user to automatically configure the instruments return configuration. When the Return lead is earth grounded, the GFI circuit is disabled and the instrument operates in a grounded return mode of operation.

Please refer to section **4.1.2 System Parameters** for a complete explanation of the GFI function.

### **2.2.4. Environmental Conditions**

This equipment is intended for indoor use only. The equipment has been evaluated according to Installation Category II and Pollution Degree 2 as specified in IEC 664.

This instrument may be operated in temperatures from 32° - 104° F (0° - 40° C).  
Relative humidity of 0 to 80%.  
Altitude up to 6,560 feet (2,000 meters).

### **Storage and Shipping Environment**

This instrument may be stored or shipped in environments with the following limits:

Temperature.....-40° - 167° F ( -40° - 75°C)

Altitude .....50,000 feet (15,240 meters)

The instrument should also be protected against temperature extremes that may cause condensation within the instrument.

### 3. Specifications and Controls

#### 3.1. HypotULTRA III Functional Specifications, 7620 and 7650

INPUT	
Voltage	115 / 230 VAC $\pm$ 10 %, automatically selected
Frequency	50/60 Hz $\pm$ 5%
Fuse	4 Amp 250V Slo-Blo

DIELECTRIC WITHSTAND TEST MODE	
Output Rating	5 KV @ 30 mA AC 5 KV @ 10 mA DC for 7650 only
Output Adjustment	Range: 0 – 5000V AC 0 – 5000V DC for 7650 only Resolution: 1 Volt Accuracy: $\pm$ (2% of setting + 5 volts) (Can be adjusted during operation. Disabled when key lockout is active.)
Ramp-HI	12mA peak maximum, ON/OFF selectable
Charge-LO	Range: 0.0 – 350.0 $\mu$ A DC or Auto set
Max and Min-Limit	
AC Total	Range 1: 0.000 – 9.999mA Resolution: 0.001mA Range 2: 10.00 – 30.00 mA Resolution: 0.01 mA Accuracy: $\pm$ (2% of setting + 2 counts)
AC Real	Range 1: 0.000 – 9.999mA Resolution: 0.001mA Range 2: 10.00 – 30.00 mA Resolution: 0.01 mA Accuracy: $\pm$ (3% of setting + 0.05mA) All Ranges PF > 0.1 V > 250VAC

<b>DIELECTRIC WITHSTAND TEST MODE</b>	
DC	Range 1: 0.0 – 999.9 $\mu$ A for 7650 only Resolution: 0.1 $\mu$ A Range 2: 1000 – 10000 $\mu$ A for 7650 only Resolution: 1 $\mu$ A Accuracy: $\pm$ (2% of setting + 2 counts)
Arc Detection	Range: 1 – 9
Failure Detector	Audible and Visual
Voltage Display	Range: 0.00 – 5.00 KV Full Scale Resolution: 10 volts Accuracy: $\pm$ (2% of setting + 2 counts)
Current Display	Auto Range
AC Total	Range 1: 0.000mA – 3.500mA Resolution: 0.001mA Range 2: 3.00 – 30.00 mA Resolution: 0.01 mA Accuracy: $\pm$ (2% of reading + 2 counts)
AC Real	Range : 0.000mA – 30.00mA Resolution: 0.001mA or 0.01mA Accuracy: $\pm$ (3% of reading + 0.05mA) All Ranges PF > 0.1 V > 250VAC
DC	Range 1: 0.0 $\mu$ A – 350.0 $\mu$ A for 7650 only Resolution: 0.1 $\mu$ A Range 2: 0.300 mA – 3.500 mA for 7650 only Resolution: 0.001mA Range 3: 3.00 mA – 9.99 mA for 7650 only Resolution: 0.01mA Accuracy: $\pm$ (2% of reading + 2 counts)
DC Output Ripple	$\leq$ 4% Ripple RMS at 5 KV DC @ 10 mA, Resistive Load
Discharge Time	$\leq$ 200 ms

DIELECTRIC WITHSTAND TEST MODE	
Maximum Capacitive Load in DC Mode	1uF----< 1KV      0.08uF----< 4KV 0.75uF----< 2KV      0.04uF----< 5KV 0.5uF----< 3KV
AC Output Wave Form	Sine Wave, Crest Factor = 1.3 – 1.5
Output Frequency	Range: 60 or 50 Hz, User Selection Accuracy: ± 0.1%
Output Regulation	± (1 % of output + 5 V) From no load to full load and over input voltage range
Dwell Timer	Range: 0.0, 0.4 – 999.9 sec (0 = Continuous) Resolution: 0.1 sec Accuracy: ± (0.1% + 0.05 sec)
Ramp Timer	Range: Ramp-Up: 0.1 – 999.9 sec Ramp-Down: AC 0.0 – 999.9 sec DC 0.0, 1.0 – 999.9 sec 0.0=OFF Resolution: 0.1 sec Accuracy: ± (0.1% + 0.05 sec)
Ground Continuity	Current: DC 0.1 A ± 0.01A, fixed Max. ground resistance: 1 Ω ± 0.1Ω, fixed
Ground Fault Interrupt	GFI Trip Current: 450 μA max (AC or DC) HV Shut Down Speed: < 1ms

INSULATION RESISTANCE TEST MODE, MODEL 7650 ONLY	
Output Voltage	Range: 50 – 1000 Volts DC Resolution: 1 Volt Accuracy: ± (2% of reading + 2 volts)
Short Circuit Current	Maximum: 12mA peak
Voltage Display	Range: 0 – 1000 V Resolution: 1 Volt Accuracy: ± (2% of reading + 2 counts)



INSULATION RESISTANCE TEST MODE, MODEL 7650 ONLY																
Resistance Display	Range: 0.05MΩ – 50000 MΩ (5 Digit, Auto Ranging) Resolution: 500VDC 1000VDC <table border="1"> <thead> <tr> <th>MΩ</th> <th>MΩ</th> <th>MΩ</th> </tr> </thead> <tbody> <tr> <td>0.001</td> <td>0.050 – 9.999</td> <td>0.100 – 9.999</td> </tr> <tr> <td>0.01</td> <td>1.00 – 99.99</td> <td>1.00 – 99.99</td> </tr> <tr> <td>0.1</td> <td>10.0 – 999.9</td> <td>10.0 – 999.9</td> </tr> <tr> <td>1</td> <td>100 – 50000</td> <td>100 – 50000</td> </tr> </tbody> </table> Accuracy: 50 – 499V 0.05MΩ – 999.9MΩ, ± (7% of reading + 2 counts) 500 – 1000V 0.10MΩ – 999.9MΩ, ± (2% of reading + 2 counts) 1000MΩ – 9999MΩ, ± (5% of reading + 2 counts) 10000MΩ – 50000MΩ, ± (15% of reading + 2 counts)	MΩ	MΩ	MΩ	0.001	0.050 – 9.999	0.100 – 9.999	0.01	1.00 – 99.99	1.00 – 99.99	0.1	10.0 – 999.9	10.0 – 999.9	1	100 – 50000	100 – 50000
MΩ	MΩ	MΩ														
0.001	0.050 – 9.999	0.100 – 9.999														
0.01	1.00 – 99.99	1.00 – 99.99														
0.1	10.0 – 999.9	10.0 – 999.9														
1	100 – 50000	100 – 50000														
Charge-LO	Range: 0.000 – 3.500μA or Auto Set															
Maximum and Minimum Limits	Range: 0.0, 0.05MΩ – 99.99MΩ Resolution: 0.01MΩ Range: 100.0MΩ – 999.9MΩ Resolution: 0.1MΩ Range: 1000MΩ – 50000MΩ Resolution: 1MΩ (Max Limit: 0 = OFF) Accuracy: Same as Resistance Display Accuracy															
Ramp Timer	Range: Ramp-Up: 0.1 – 999.9 sec Ramp-Down: 0.0, 1.0 – 999.9 sec Resolution: 0.1 sec Accuracy: ± (0.1% + 0.05 sec)															
Delay Timer	Range: 0.0, 1.0 – 999.9 sec 0 = Continuous Resolution: 0.1 sec Accuracy: ± (0.1% + 0.05 sec)															
Ground Fault Interrupt	GFI Trip Current: 450 μA max HV Shut Down Speed: < 1ms															

CONTINUITY TEST MODE	
Output Current	DC 0.1A ± 0.01A      Total Resistance*: 0.00-33.0 Ω DC 0.01A ± 0.001A      Total Resistance*: 31.0-330 Ω DC 0.001A ± 0.0001A      Total Resistance*: 310-2000 Ω
Resistance Display	Range 1: 0.00 – 19.99 Ω Resolution: 0.01 Ω Accuracy: ± (1 % of reading + 0.05 Ω) Range 2: 20.0 – 199.9 Ω Resolution: 0.1 Ω Accuracy: ± (1 % of reading + 0.2 Ω) Range 3: 200 – 2000 Ω Resolution: 1 Ω Accuracy: ± (1 % of reading + 2 Ω)
Maximum and Minimum Limits	Range 1: 0.00 – 99.99 Ω Resolution: 0.01 Ω Accuracy: ± (1% of setting+0.05 Ω) Range 2: 100.0 – 999.9 Ω Resolution: 0.1 Ω Accuracy: ± (1% of setting+0.2 Ω) Range 3: 1000 – 2000 Ω Resolution: 1 Ω Accuracy: ± (1% of setting+2 Ω) (Max Limit: 0 = OFF)
Dwell Timer	Range: 0.0, 0.3 – 999.9 sec (0 = Continuous) Resolution: 0.1 sec Accuracy: ± (0.1% + 0.05 sec)
Milliohm Offset	Range: 0.00 – 10.00Ω Resolution: 0.01 Ω Accuracy: ± (1 % of reading + 0.05 Ω)

\* - Total Resistance includes resistance of Test leads, Fixture, and DUT.

GENERAL SPECIFICATIONS	
PLC Remote Control	Input: Test, Reset, Interlock, Recall Memory 1 through 10 Output: Pass, Fail, Test-in-Process, Reset
Remote Output Relays	125VAC@1AAC, 30VDC@ 0.5ADC
Safety	Built-in Smart GFI circuit
Memory	50 memories, 30 steps/memory
Interface	Standard RS-232, Optional Printer Port with Date and Time Stamp or GPIB.
Security	Programmable password lockout capability to avoid unauthorized access to test set-up program.
Graphic Display	240 x 64 dot resolution. Monographic LCD
Alarm Volume	Range: 0 – 9; 0 = OFF, 1 is softest volume, 9 is loudest volume.
Contrast	Range: 1 – 9; 1 is lightest character, 9 is darkest character.
Calibration	Adjustments are made through the front panel. Built-in Verification program. Automatic Calibration alert function to signal operator when calibration is due.
Environmental	Temperature: 0 – 40°C Humidity: 0 – 80%
Mechanical	Bench or rack mount (2U height) with tilt up front feet Dimensions:(w x h x d) 16.92x3.50x15.75in (430x89x400mm)
Weight	31.38 Lbs (14.23 kgs) variable with options

OPTIONS	
Scanning Matrix	4 or 8 port high voltage switching matrix with continuity.

## 3.2. Instrument Controls

### 3.2.1. Front Panel Controls

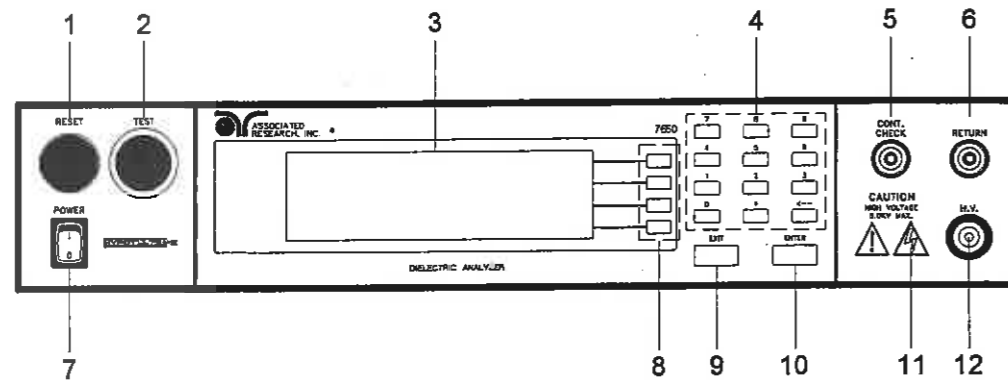

1. **RESET BUTTON:** Momentary contact switch used to reset the instrument. If a failure condition occurs during a test, you will need to reset the system to shut off the alarm and signal the system that you are aware of a failure condition. The reset button must be pressed before you can proceed to the next test or change any of the set-up parameters. This switch also serves as an abort signal to stop any test in progress controlled by the HypotULTRA III.
2. **TEST BUTTON:** Momentary contact switch used to start tests. Press the green button to activate the test that is set up in the test buffer shown on the display.
3. **GRAPHIC LCD:** 240 X 64 Monographic LCD.
4. **NUMERIC DATA ENTRY:** Keys used to enter numeric data.
5. **CONTINUITY OUTPUT JACK:** Connection for the low current return lead or three-prong receptacle adapter box used for continuity testing.
6. **RETURN OUTPUT JACK:** Connector used to attach the Return test lead or test fixture return lead to the instrument. This connection provides the return current path for the high voltage and continuity tests.
7. **POWER SWITCH:** Rocker style power switch with international ON (I) and OFF (O) markings.
8. **SOFT KEYS:** Multifunction parameter selection keys. Keys used to select screens and change parameters.
9. **EXIT KEY:** Key used to escape from parameter editing and returning to prior screens.
10. **ENTER KEY:** Key used to finalize parameter entries. The ENTER key may also be used to scroll the highlighted area to different parameters in the parameter setting screens.

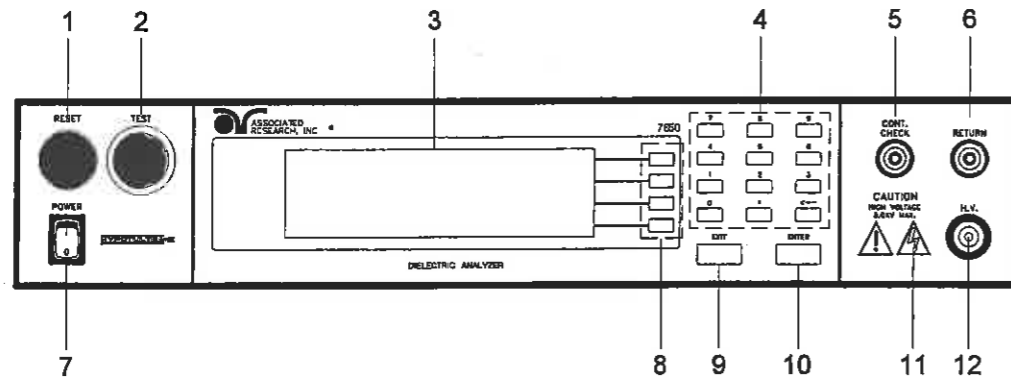

- 11. HIGH VOLTAGE ON INDICATOR:** This indicator flashes to warn the operator that high voltage is present at the high voltage terminal.
- 12. HIGH VOLTAGE OUTPUT JACK:** Connector used to attach the High Voltage test lead, adapter box high voltage lead, or test fixture high voltage lead to the instrument. The connector is recessed for safety when not being used.

### 3.2.2. Rear Panel Controls

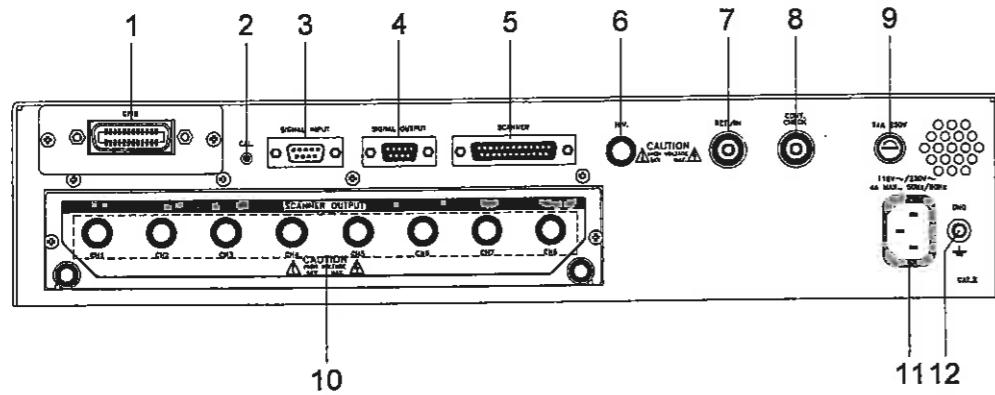

1. **BUS INTERFACE:** Standard connector for interconnection to the RS-232 Bus interface. Optional IEEE 488 interface may be substituted for the RS-232.
2. **CALIBRATION BUTTON:** To put the instrument into the calibration mode, push this button and turn on the power switch simultaneously.
3. **REMOTE SIGNAL INPUT:** 9-Pin D subminiature male connector for remote control of TEST, RESET, and INTERLOCK functions, as well as remote memory selection.
4. **REMOTE SIGNAL OUTPUT:** 9-Pin D sub-miniature female connector for monitoring PASS, FAIL, RESET, and PROCESSING output relay signals.
5. **SCANNER CONNECTOR:** For connection of optional Scanning External Matrix.
6. **HIGH VOLTAGE OUTPUT JACK:** Connector used to attach the High Voltage test lead, adapter box high voltage lead, or test fixture high voltage lead to the instrument. The connector is recessed for safety.
7. **RETURN OUTPUT JACK:** Connector used to attach the Return test lead or test fixture return lead to the instrument. This connection provides the return current path for the high voltage and continuity tests.
8. **CONTINUITY OUTPUT JACK:** Connection for the low current return lead or three-prong receptacle adapter box used for continuity testing.
9. **FUSE RECEPTACLE:** To change the fuse, unplug the power (mains) cord and turn the fuse receptacle counter-clockwise. The fuse compartment will be exposed. Please replace the fuse with one of the proper rating.
10. **SCANNER OUTPUTS:** Optional scanner matrix that provides 8 HV/Continuity/Return connections. Please refer to the Options section of this manual for additional connection information.

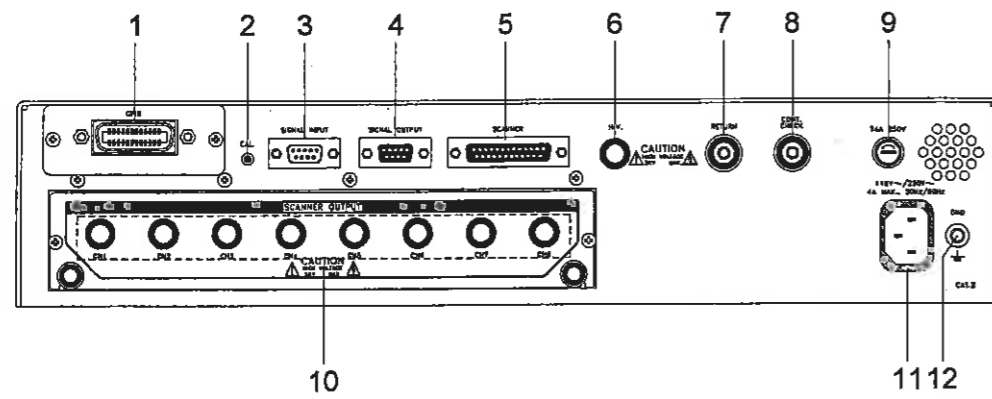

- 11. INPUT POWER RECEPTACLE:** Standard IEC 320 connector for connection to a standard NEMA style line power (mains) cord.
- 12. CHASSIS GROUND (EARTH) TERMINAL:** This terminal should be connected to a good earth ground before operation.

### 3.3. Quickstart

This quick start guide assumes the operator has some familiarity with automated Electrical Safety testing.

**WARNING** Locate a suitable testing area and be sure you have read all safety instructions for the operation of the instrument and suggestions on the test area set-up in the Safety section. Locate a three prong grounded outlet. Be sure the outlet has been tested for proper wiring before connecting the instrument to it.

**CAUTION** Connect the power-input plug into its socket on the rear panel of the instrument. Connect the male end of the plug to the outlet receptacle. Please be sure that the safety ground on the power line cord is not defeated and that you are connecting to a grounded power source.

Turn on the POWER switch located on the lower left-hand side of the front panel. The HypotULTRA III Information screen will appear with a message at the bottom indicating Press TEST for Verification. You now have the option to press the TEST button and activate the Verification Menu (Refer to the **section 7. Instrument Verification**). The option to activate the Verification expires approximately 3 seconds after power-up. If you do not press the TEST button within the 3-second window, the initialization screen will disappear. The initialization screen will appear as follows:

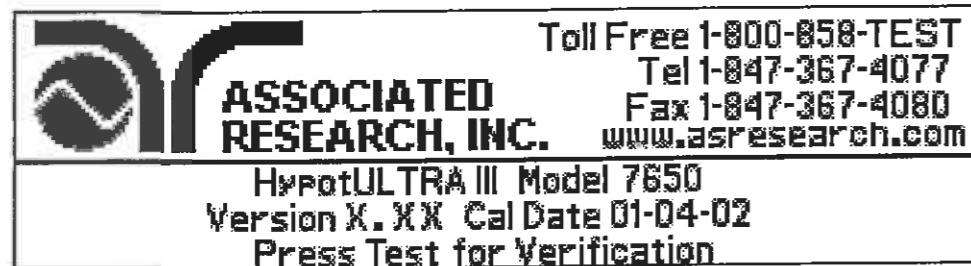



The Perform Tests screen will now be displayed. The Perform Test screen will appear as follows:

ACW Total M50-8_P	Settings 999.9s	Mem Name** 10.00mAR	Memory
<div style="display: flex; justify-content: space-around;"> <span>4.36 kV</span> <span>12.89 mA</span> </div>			Step
			Edit
			<more>

ACW Total M50-8_P	Settings 999.9s	10.00mAR	Result
<div style="display: flex; justify-content: space-around;"> <span>4.36 kV</span> <span>12.89 mA</span> </div>			System
			<top>

The HypotULTRA III comes with the Memories/Steps and System loaded with the factory defaults. The factory defaults are as follows:

Test Type	Parameter	Value
ACW	Voltage	1240V
	Max Lmt T	10.00mA
	Min Lmt T	0.000mA
	Max Lmt R	10.00mA
	Min Lmt R	0.000mA
	Display	Total
	Ramp UP	0.1s
	Dwell	1.0s
	Ramp DN	0.0s
	Connect	OFF
	Frequency	60Hz
	Arc Detect	OFF
	Arc Sense	5
	Continuity	OFF
	Scanner	00000000
	Prompt	

System Presets		
Setup Sys.	PLC Remote	OFF
	Single Step	OFF
	Fail Stop	ON
	Alarm	5
	Contrast	5

System Presets		
	Results	Last
	Lock	OFF
	Mem Lock	ON
	Address (GPIB only)	8
	Smart GFI	ON
	Results	Last
	Cal Alert	ON
	Date	mdy
Security	Password from Factory	0
	Security based on Password	OFF

The initial test loaded for use is Memory 1, Step 1. If the ACW defaults are unacceptable for your DUT then refer to the section **4.2 Setting Up a Test**, for instructions on how to program tests into the instrument.

If these parameters are acceptable, then connect an appropriate set of test leads to the device under test (DUT) or test fixture. Connect the return lead (Black) to the DUT or test fixture followed by the high voltage output lead (Red). Make sure the safety ground of this instrument is connected to a known good ground.

Refer to section **4.1.2 System Parameters**, Smart GFI, for an explanation of DUT grounding configurations.

**WARNING** DO NOT TOUCH THE DEVICE UNDER TEST ONCE THE TEST HAS BEEN STARTED.

#### Remote Interlock

HypotULTRA III is equipped with a feature referred to as “Remote Interlock”. Remote Interlock is a feature that utilizes a set of closed contacts to enable the instruments output. In other words, if the Interlock contacts open, the output of the instrument will be disabled. Remote Interlock could also be referred to as a remote system lockout, utilizing “Fail When Open” logic.

If the Interlock contacts are open and the Test button is pushed, a pop-up message will be displayed on the screen for two seconds. The message will appear as follows:

**Interlock is Open**

If the Interlock contacts are opened during a test, the pop-up message will be displayed and the test will abort. The hardware has been configured to provide the interlock connections on pins 4 and 5 of the Remote Interface, Signal Input port. The instrument can still be used without the external interlock device as long as the Interlock Connector (38075 provided with unit) is plugged into the Remote Interface, Signal Input port. If there is nothing connected to

the Remote Interface, Signal Input port to provide a connection to the interlock, the instrument will not perform tests.

Please check your connections to be sure they are making good contact. Clear the area of any debris that may create a hazardous situation and ask any unnecessary personnel to leave the area. To initiate the test, press the GREEN TEST button on the front panel. This is a momentary button and does not need to be held in the pressed position during the test. The instrument will then initiate the test presently loaded from the selected memory.

If the DUT passes the step, you will hear a short audible beep. If a failure occurs during a step, you will hear a long audible alarm and the red failure indicator will light up. If the fail stop is set to OFF and the Connect is set to ON, then the next step in the sequence will begin. If a failure occurs during any step of the test sequence, a continuous alarm will sound and the red indicator light in the Reset button will illuminate at the end of the last step.

To stop the alarm you must press the illuminated RED button marked RESET. This will silence the alarm. Pressing the RESET again will clear the red fail light, and reset the instrument for the next test. The RESET button may also be used to quickly ABORT a test and cut off the power to the DUT.

When a test is being performed, a red lightning bolt indicator located in the lower right side of the front panel will illuminate and flash until the test is finished. If the DUT passed the entire test sequence, you will hear a brief beep indicating the DUT passed and that the tests are complete.

## 4. Programming Instructions

### 4.1. Setup System (Refer to FIG.1).

1. From the Perform Test screen, press the "<more>" soft key. A second set of soft key selections will now be displayed.
2. From the secondary soft keys, press the "System" soft key. The Setup System parameters will now be displayed.
3. At the Setup System menu, you may scroll to all of the parameters by using the arrow keys.
4. If the printer card is installed, Scrolling to <more> will display the second page of System Parameters that contain the printer functions.

From the Setup System selections, sixteen different Hardware and Software controls may be accessed; PLC Remote, Single Step, Fail Stop, Alarm, Contrast, Lock, Mem Lock, GPIB Address, Smart GFI, Results, Cal Alert, Cal Date, Cal Due, Alert, Date, and Time. Pressing the EXIT key at any time will return you to the Perform Test screen.

FIG.1

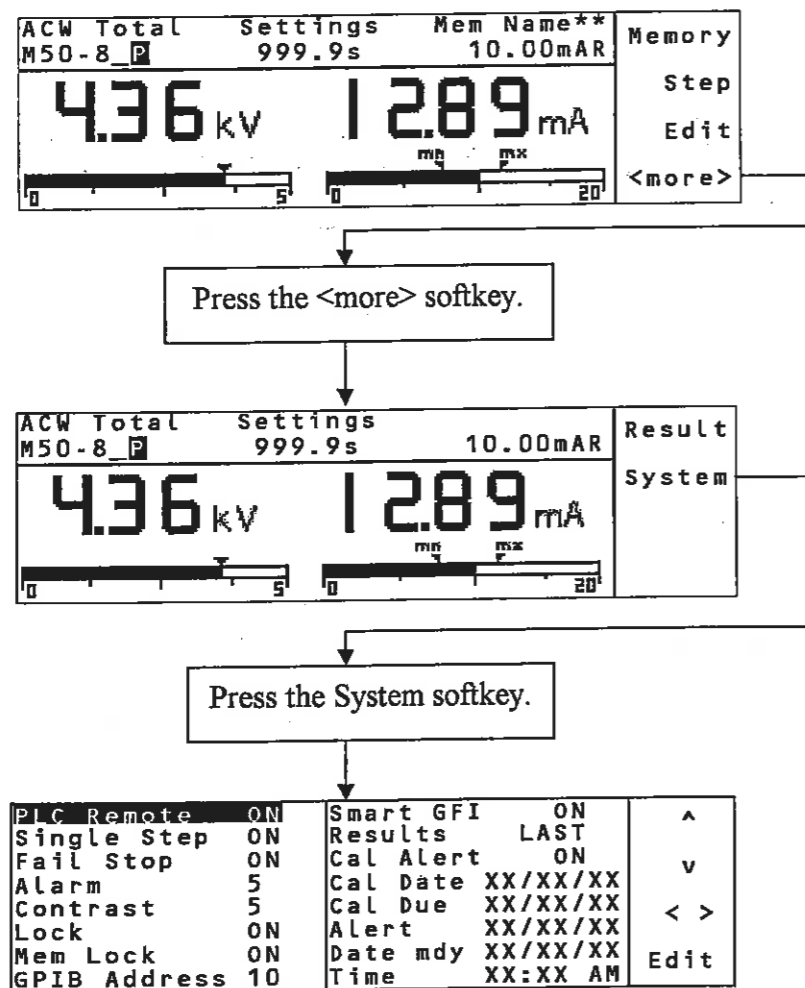

#### 4.1.1. Setup System Soft keys

##### Directional soft keys <, >, ^, v

The “< >, ^, v” soft keys are used to scroll the cursor to the different system parameters.

##### Edit

The “Edit” soft key is used to access the highlighted parameter and activates the Editing Menu.

An example of one of the editing menus is as follows:

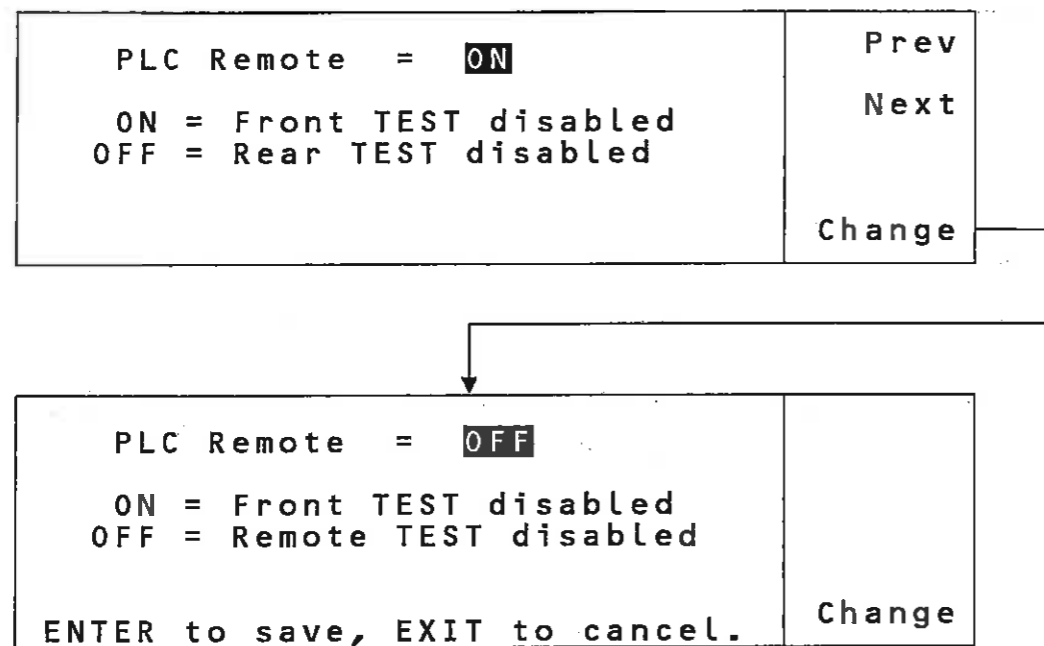

If the selected parameter is a toggle selection, as shown in the example above, the bottom soft key will have the word “Change” next to it. After the “Change” soft key is pressed, the parameter will toggle and you will be prompted to press ENTER to save or EXIT to cancel the edit.

If the parameter is numeric, you may type in a new number using the numeric keypad. Once you begin typing a new number, the parameter will blank and the cursor will begin blinking. This indicates that the parameter is being edited. Once a parameter is edited, it is necessary to complete the edit either by pressing the ENTER key to accept the new number or the EXIT key to cancel the edit and return to the original number.

##### Prev and Next

Once the Editing Menus are active, you may scroll through all of the different editing menus by pressing the “Prev and Next” soft keys.

### Change

The “Change” soft key is used to toggle parameters in the edit menus.

### EXIT

The “EXIT” key is used to return to the Perform Tests screen from the Setup System Menu or will bring you back to the Setup System Menu from the Editing Menus.

#### 4.1.2. System Parameters

Once the “Edit” soft key has been pressed from the System parameter listing you may scroll to and edit all of the parameters by pressing the “Prev and Next” soft keys.

Once a parameter is edited, it is necessary to complete the edit either by pressing the ENTER key to accept the change or the EXIT key to escape from the edit and return to the original setting.

### PLC Remote

Highlight the PLC Remote parameter using the “ < >, ^, v ” soft keys. When PLC Remote parameter is highlighted, press the “Edit” soft key.

The PLC Remote, editing menu will now be displayed. You may turn the PLC remote function ON and OFF by pressing the “Change” soft key. Accept the change by pressing ENTER or cancel the edit by pressing EXIT. Refer to the section **6.Connection of Remote I/O** for details.

When the PLC remote is turned “ON”, the front panel Test button is disabled and a test may only be started through the rear panel I/O. If you attempt to start a test from the front panel Test button when the PLC Remote function is turned “ON”, a pop-up message will be displayed. The pop-up message will appear as follows:



### Single Step

Highlight the Single Step parameter using the “ < >, ^, v ” soft keys. When Single Step parameter is highlighted, press the Edit key.

The Single Step, editing menu will now be displayed. You may turn the Single Step function ON and OFF by pressing the “Change” soft key. Accept the change by pressing ENTER or cancel the edit by pressing EXIT.

This function is used to temporarily override the automatic connection feature. When the Single Step function is ON the instrument will pause after each step is completed. To continue

the test sequence, press the Test button to execute the next connected step. Each time the Test button is pressed the next connected step will execute. If you press the Reset button before completing all connected steps, it will return you to the original starting step. If a step fails and you wish to continue to the next step, do not press Reset.

### **Fail Stop**

Highlight the Fail Stop parameter using the “< >, ^, v” soft keys. When Fail Stop parameter is highlighted, press the Edit key.

The Fail Stop, editing menu will now be displayed. You may turn the Fail Stop function ON and OFF by pressing the “Change” soft key. Accept the change by pressing ENTER or cancel the edit by pressing EXIT.

Fail Stop is a function that will stop a sequence of tests at the step if a failure occurs. If this function is turned off, the sequence of tests will continue to the end of the sequence regardless of whether or not a failure has occurred. If the Fail stop is off and a failure occurs during the test sequence, the RESET button will light and a short alarm will sound but the sequence will continue to the end. At the end of the test sequence, the RESET button will light and alarm will sound indicating failure during the sequence. Pressing the RESET button will silence the alarm and reset the instrument. Turn the Fail Stop function ON and OFF by pressing the “Change” soft key. Accept the change by pressing ENTER or cancel the edit by pressing EXIT.

### **Alarm Volume**

Highlight the Alarm parameter using the “< >, ^, v” soft keys. When the Alarm parameter is highlighted, press the “Edit” soft key.

The Alarm Volume, editing menu will now be displayed. To change the volume of the alarm, type in a numeric value between 0 and 9. Press the ENTER key to accept the new number or the EXIT key to escape from the edit and return to the original number.

The numbers corresponding to the different volume settings are 0 through 9, 0 meaning the volume is off, and 9 being the loudest setting. After the number is entered, a momentary alarm chirp will occur to indicate the volume of the new setting.

### **LCD Contrast**

Highlight the Contrast parameter using the “< >, ^, v” soft keys. When the Contrast parameter cursor is highlighted, press the “Edit” soft key.

The Contrast, editing menu will now be displayed. To change the Contrast of the display, type in a numeric value between 0 and 9. Press the ENTER key to accept the new number or the EXIT key to escape from the edit and return to the original number.

The numbers corresponding to the different contrast settings are 0 through 9, 0 meaning the lightest color of displayed characters and 9 meaning the darkest color of displayed characters. After the number is entered, the display will automatically adjust to the new display setting.

**Results**

Highlight the Results parameter using the “< >, ^, v” soft keys. When the Results parameter is highlighted, you may use the “Change” soft key to select what type of results you would preferred displayed at the end of a test or sequence of connected steps. The available selections are: All, P/F and Last. Press the ENTER key to accept the new setting or the EXIT key to cancel and return to the original setting.

When All is selected, a Results summary screen will be displayed at the end of the test or sequence of connected steps, displaying the results of all of the steps. The Results summary screen will appear as follows:

01-7	ACW	Pass		x.xxkV	xx.xxmA	^
01-8	DCW	Max Lmt		x.xxkV	xx.xxmA	
02-1	ACW	Max Lmt R		x.xxkV	xx.xxmA	v
02-2	DCW	Pass		x.xxkV	xx.xxmA	
02-3	IR	Pass		xxxxV	xx.xxMΩ	
02-4	Cont	Pass			xx.xxΩ	

When P/F is selected, a Pass or Fail screen will be displayed at the end of the test. The Pass and Fail screens will appear as follows:

**PASS**

**FAIL**



When P/F is selected, it is not possible to directly see the results of the test. In order to review the test results refer to section 4.2.3 **Reviewing Test Results**.

When Last is selected, the results of the last step performed will be displayed on the Perform Tests screen. There will not be a change in appearance or special screen displayed in this mode.

## Security

### Creating a Password

The main reason for the creation of a password is to prevent unauthorized access of Lock parameters in the system menu and unauthorized disabling of the Calibration Alert function. Once a password has been created both the lock functions and the Calibration Alert Screen disable will require the password to access.

Press and hold the top soft key while powering up the instrument, the Edit Password screen should now be displayed. The display will appear as follows:

EDIT PASSWORD	
New Password=	<input type="text" value="XXXXXX"/>
Confirm Password=	<input type="text" value="XXXXXX"/>
Set the Password to 0 to disable.	

You may now type in the new password using the numeric keypad, press the ENTER key to accept the new password or press the EXIT key to escape. After you type in your new password, you will be required to confirm your new password by typing it again into the "Confirm Password" field. Press the ENTER key to confirm the new password or press the EXIT key to escape.

If the Password is set to 0, the Lock and Mem Lock parameters may be accessed by simply pressing the "Lock and Mem Lock" soft keys. If the password has been set to anything but 0, a password entry pop-up screen will appear to access the Lock and Mem Lock parameters. The Password default is preset to 0 at the factory.

Please refer to the Calibration Alert section of the manual for an explanation of how the password affects the Calibration Alert Disable.

### Forgotten Password

If you have forgotten your password, you may access all security functions by typing in the number "7600" into the password field. The old password cannot be recovered. A new password should be entered or enter "0" to disable the password.

### Secure Lock and Mem Lock Access

If a password has been created, when you press the “Lock or Mem Lock” soft key, a password pop-up screen will appear. The pop-up message will appear as follows:

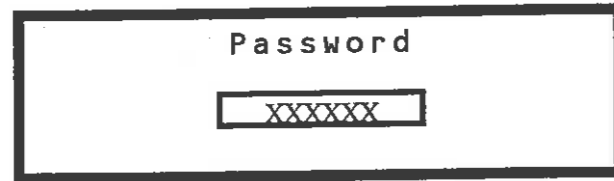

In order for you to access the Lock or Mem Lock parameters, you will now have to enter the proper password. If you have forgotten the password, please refer to the **Forgotten Password** instructions in the Security section.

### Lock

Highlight the Lock parameter using the “< >, ^, v” soft keys. When the Lock parameter is highlighted, you may turn the function ON and OFF by pressing the “Change” soft key. Press the ENTER key to accept the new setting or the EXIT key to cancel and return to the original setting. When the ENTER key is pressed, the new security setting will take immediate effect. Selecting Lock “ON” restricts access to parameter and system settings. The level of security is determined by the Mem Lock function.

### Mem Lock

Highlight the Mem Lock parameter using the “< >, ^, v” soft keys. When the Mem Lock parameter is highlighted, you may turn the function ON and OFF by pressing the “Change” soft key. Press the ENTER key to accept the new setting or the EXIT key to cancel and return to the original setting.

Mem Lock is a sub-function of the Lock setting. In order for the Mem Lock function to work, the Lock must first be turned “ON”. Selecting the Mem Lock “OFF” will allow the user to access all available Memory locations and steps but restricts access to memory and step editing capabilities. Selecting the Mem Lock “ON” will allow the user to only run the currently loaded memory.

### Smart GFI

Highlight the Smart GFI parameter using the “< >, ^, v” soft keys. When the Smart GFI parameter cursor is highlighted, you may turn the function ON and OFF by pressing the “Change” soft key. Press the ENTER key to accept the new setting or the EXIT key to cancel and return to the original setting.

The High Voltage power supply of the instrument is internally referenced to earth ground. The leakage current measuring circuits monitor only currents that flow through the Return lead. Therefore, the possibility exists for current to flow directly from the High Voltage output to earth ground that typically would not be monitored.

GFI is a circuit that monitors the current between the High Voltage output and earth ground. The GFI's main purpose is to protect the operator from prolonged exposure to High Voltage in the case of an accidental contact with the High Voltage lead and earth ground. If the operator accidentally touches the High Voltage lead and earth ground, the High Voltage will be shut off immediately and the test aborted. If the GFI threshold is exceeded, the display will indicate a GFI Fail.

Smart GFI allows the user to automatically configure the instruments return configuration. When the Return lead is earth grounded, the GFI circuit is disabled and the instrument operates in a grounded return mode of operation. Grounded Return allows the user to perform tests on devices that have their chassis earth grounded by the test fixture or test environment. The standard configuration of HypotULTRA III is a floating return connection that is not directly connected to Earth ground. The standard configuration allows monitoring of very low-level leakage current without internal or external stray earth ground leakage currents being measured and thereby causing errors in the reading. Grounding the return will create some amount of leakage current that is proportional to the High Voltage output and can cause small amounts of error depending on the test voltage and physical environment.

#### **4.1.3. Cal Alert (Calibration Alert)**

Calibration Alert is a feature that allows the instrument to give an advanced alert that the calibration for the instrument is coming due. Highlight the Cal Alert parameter using the “< >”, “^, v” soft keys. When the Cal Alert parameter is highlighted, you may turn the function ON and OFF by pressing the “Change” soft key. Press the ENTER key to accept the new setting or the EXIT key to cancel and return to the original setting.

Turning this parameter “ON” will activate the Cal Alert function and when the date matches the Alert Date, the instrument will display the Calibration Alert Warning screen upon power up. If the “Show this screen again?” function has been turned “OFF” at the Calibration Alert Warning screen, this parameter will automatically be set to “OFF”.

#### **Cal Date (Calibration Date)**

Calibration Date is a non-editable parameter that indicates the Date when calibration was last performed on the instrument. This parameter automatically updates after calibrating the instrument.

#### **Cal Due (Calibration Due Date)**

It is recommended that calibration should be performed at least once a year. It is recommended that the Calibration Due date not be set greater than one year from the Calibration Date displayed. After a calibration is performed, the Calibration Due Date is automatically set 1 year after the calibration date.

This parameter defaults to one year after the calibration date but may be overwritten to any advanced date desired. Within the Calibration Due Date parameter are three separate fields, month, day, and year. Use the “< >” soft keys to select the field within the date you want to

edit. Use the numeric keypad to change the values in the Date fields and press ENTER to accept the new number or press EXIT to cancel and return to the original number.

#### **Alert (Alert Date)**

The Alert date is like an alarm clock that will warn you in advance of the actual calibration due date. After a calibration is performed, the Alert Date is automatically set 11 months after the calibration date. For example, if the calibration is performed on 12/15/2003 the Alert Date will automatically be set to 11/15/2004.

This parameter defaults to 11 months after the calibration date but may be overwritten to any advanced date desired. Within the Alert Date parameter are three separate fields, month, day, and year. Use the “< >” soft keys to select the field within the date you want to edit. Use the numeric keypad to change the values in the Date fields and press ENTER to accept the new number or press EXIT to cancel and return to the original number.

#### **Date**

Highlight the Date parameter using the “< >, ^, v” soft keys.

Within the Set Date parameter are four fields, date format (mdy / dmy), month, day, and year. Use the “< >” soft keys to select the field within the date you want to edit. Use the “Change” soft key for toggling the date format parameter or use the numeric keypad to change the values in the Date fields. Press ENTER to accept the new number or press EXIT to cancel and return to the original number.

#### **Time**

Scroll the cursor to the Time parameter using the “< >, ^, v” soft keys.

Within the Set Time parameter are three fields, hours, minutes, and Military or Standard time setting. Use the “< >” soft keys to select the field within the date you want to edit. Use the numeric keypad to change the values in the Date fields and press ENTER to accept the new number or press EXIT to cancel and return to the original number.

### Calibration Alert Screen

The Calibration Alert Warning screen appears as follows:

With all security settings set to off.

<b>CALIBRATION ALERT</b> Model 7650 is due for calibration on 10/16/05. Contact Associated Research to arrange for calibration.	
Show this screen again?	Yes
Call 1-800-858-8378	OK

With security set to ON and password enabled.

<b>CALIBRATION ALERT</b> Model 7650 is due for calibration on 10/16/05. Contact Associated Research to arrange for calibration.	
Password <div style="border: 1px solid black; width: 100px; height: 20px; margin: 0 auto;">           XXXXXX         </div>	
Show this screen again?	Yes
Call 1-800-858-8378	OK

At the Calibration Alert Warning screen, there are two options, "Show screen again?", Yes or No". "Show screen again?" is asking if you would like to continue seeing the Calibration Alert Warning screen every time you power up the instrument. The question must be answered by toggling between the word "Yes" and "No" using its corresponding softkey and then pressing the OK softkey. You may turn this screen "OFF" by toggling to the word "No" using the soft key next to this parameter and pressing the "OK" soft key. Selecting the "Show this screen again" parameter "No" will disable the Calibration Alert function. You may leave this screen "ON" by toggling to the word "Yes" using the soft key next to this parameter and then pressing the "OK" soft key. Selecting the "Show this screen again" parameter "Yes" will exit the Calibration Alert Warning screen and go to the Perform Test screen without disabling the Calibration Alert function.

If the security is enabled without a password (password set to 0), you will not see the question "Show screen again" or the "Yes/No" soft key. The only option available is to press the "OK" soft key. This guarantees that while the security is enabled that the Calibration alert once tripped cannot be disabled with out going to the Systems menu and turning it off.

If the security is enabled with a password, the Password pop-up screen will appear over the Calibration alert screen. The instrument while in this state will be virtually unusable until the password is entered. Once the password is entered, the security at the Calibration Alert screen will be bypassed and the "Show screen again", Yes or No, options will be available as described previously.

#### 4.1.4. System Presets

HypotULTRA III comes from the factory with the following system presets:

System Presets		
Setup Sys.	PLC Remote	OFF
	Single Step	OFF
	Fail Stop	ON
	Alarm	5
	Contrast	5
	Results	Last
	Lock	OFF
	Mem Lock	ON
	Address (GPIB only)	8
	Smart GFI	ON
	Results	Last
	Cal Alert	ON
	Security	Password from Factory
Security based on Password		OFF

The system presets may be reinitialized by following the instructions given in section 4.4 **Memory, Step, and Default System Parameter Initialization.**

## 4.2. Setting Up a Test (Refer to FIG.2).

### 4.2.1. Selecting a Memory

From the Perform Tests screen, press the "Memory" soft key. The Memory Recall screen will now be displayed.

Memory = 12	Name
Name =	List
Range: 0 - 50	
ENTER to recall, EXIT to cancel.	

Two methods may be used to select a Memory.

1. Type in the number of the Memory that you would like to use. As with all of the parameters, once you begin typing a new number, the parameter will blank and the cursor will begin blinking. This indicates that the parameter is being edited. Once a parameter is edited, it is necessary to complete the edit either by pressing the ENTER key to accept the new number or the EXIT key to escape from the edit and return to the original number.
2. Press the "List" soft key and scroll the highlighted area to the desired Memory, then press the ENTER key. An example of the list display is as follows:

01 OUTLET	^
02 PIECEPART	
03 TOASTER 12	v
04 OVEN	
05 FAN	Page ^
06 MACHINE	
07 123	Page v
08 456	

Once you press the ENTER key, the Memory location and all of its steps will be loaded into the instruments active memory for use. Once the Memory is loaded, the Perform Test screen will once again be displayed.

### 4.2.2. Naming a Memory

At the Memory recall screen, press the "Name" soft key. The character map screen will now be displayed.

ABCDEFGHI JKLMNOPQR STUVWXYZ * - _ ~ space	PRODUCT 99	< > v
ENTER to save, EXIT to cancel.		Select

Use the “< >, ^, v” soft keys to navigate through the character map and use the bottom soft key to select a character. The backspace key may be used to delete the last character. Press ENTER to save or EXIT to cancel changes. The memory name can be no more than 10 characters in length.

#### 4.2.3. Selecting a Step

From the Perform Tests screen, press the “Step” soft key. The soft keys will now change to Step -, Step +, and Edit. The display will appear as follows:

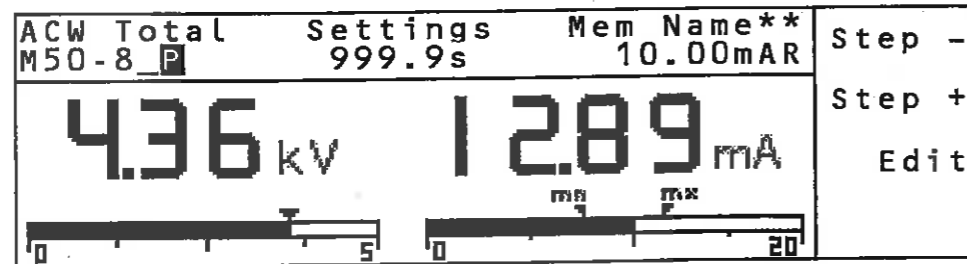

You may now select a step by using the “+” and “-” step keys. Once you have located the desired step, you may access the step’s parameters by pressing the “Edit” soft key.

#### 4.2.4. Reviewing Test parameters

From the Perform Tests screen, press the “Edit” soft key. The Test parameter review screen will now be displayed for the selected memory location and step (For the example an AC withstand test is displayed). You may now review the test parameters by scrolling the highlighted area with the arrow keys. It is important to note that there may be two screens of parameters for the selected test and the additional parameters may be accessed using the “<more>” soft key.

#### 4.2.5. Editing Test Parameters (Refer to FIG.2)

From Test Parameter edit screen, you may set your own custom set of parameters for the test or choose the ACW, DCW, IR, and Continuity defaults. All of the individual parameters for the test may be accessed using the “Prev and Next” soft keys. As the “Prev and Next” soft keys are pressed, the screen will change for the different parameters. The ENTER key may also be used to scroll to the different parameters. For a detailed explanation of the Scanner parameter and how this feature works, refer to the **section 9 Options**.

1. From the Test parameter review screen (refer to section 4.2.4), scroll the highlighted area to the test parameter you wish to edit using the “< >, ^, v” soft keys.
2. Press the “Edit” soft key. The Test Parameter edit screen will now be displayed.
3. To change numeric parameters, simply type the new number in using the numeric keys. Once you begin typing a new number, the parameter will blank and the cursor will begin blinking. This indicates that the parameter is being edited. Once a parameter is edited, it is necessary to complete the edit either by pressing the ENTER key to accept the new number or the EXIT key to cancel the edit and return to the original number. The one exception to this rule is the scanner parameter. The scanner parameter will not blank when being edited.



To change toggle parameters, simply press the "Change" soft key. Once a parameter is edited, it is necessary to complete the edit either by pressing the ENTER key to accept the new setting or the EXIT key to cancel the edit and return to the original number.

FIG.2

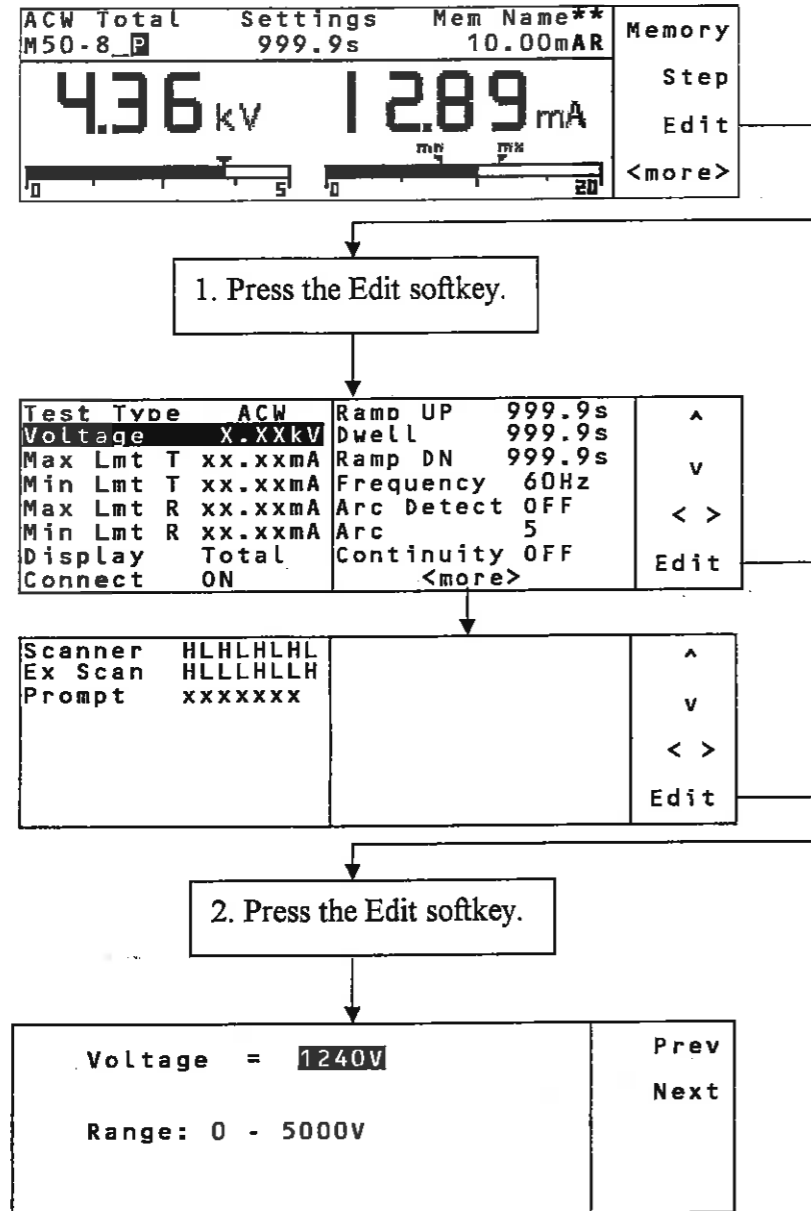

When you are done modifying test parameters, press the EXIT key twice to return to the Perform Test screen.

The instrument is now ready to perform tests with the modified parameters.

**4.2.6. Prompt**

The Prompt function allows you to insert a short line of text in a step. The Prompt will appear on the screen before the step is initiated and remains on the screen until the TEST button is pressed. After the TEST button is pressed, the Prompt will clear and the step will initialize.

At the Perform Test screen, use the “Memory and Step” soft key functions to select the desired test step that you would like the prompt to appear before.

At the Perform Test screen, press the “Edit” soft key.

Scroll the highlighted area to the “Prompt” parameter and press ENTER.

The character map screen will now be displayed. The character map will appear as follows:

ABCDEFGHI JKLMNOPQR STUVWXYZ * - _ ~ space	THIS IS A PROMPT MESSAGE.	Prev  Next
		Edit

This screen will only show when scrolling one parameter at a time through the parameter list with “Prev and Next” soft keys. Press the “Edit” soft key to Edit or insert a Prompt.

ABCDEFGHI JKLMNOPQR STUVWXYZ * - _ ~ space	THIS IS A PROMPT MESSAGE.	<  >  v
ENTER to save, EXIT to cancel.		Select

To enter a text prompt, use the arrow keys to scroll the highlighted area to the character (or enter a number from the numeric keypad) you wish to use and then press the “Select” soft key, the letter or symbol will be inserted at the point where the cursor is flashing. The cursor will then increment to the next position and wait for an additional character insertion. If you make a mistake or want to change the character, press the backspace key in the numeric keypad. The cursor will decrement and erase the character. When you have finished editing the prompt press the ENTER key. After a prompt is inserted in a step, a “P” will appear within the step parameters below the step number.

### 4.3. Test Parameters

#### Test Parameter Notes

- Once you begin typing a new number, the parameter will blank and the cursor will begin blinking. This indicates that the parameter is being edited. Once a parameter is edited, it is necessary to complete the edit either by pressing the ENTER key to accept the new number or the EXIT key to escape from the edit and return to the original number. The one exception to this rule is the scanner parameter. The scanner parameter will not blank when being edited.
- When the ENTER key is pressed to accept a parameter change, the instrument will automatically bring up the next Test Parameter edit screen.
- The Test Parameter edit screen displays the “Range” of the parameter that is highlighted. Use this as a guide when setting your parameters.
- The “Change” softkey in the parameter menus selects different conditions and no data entry is required i.e. The “Change” softkey in the AC withstand toggles between 50Hz and 60Hz. It is necessary to press the ENTER key to accept the new parameter or press EXIT to cancel from the edit.
- Selecting the test type (ACW, DCW, and IR) automatically loads the default parameters for that particular type of test. Refer to section 4.3.6 for the preset default parameters.
- Scanner and External scanner parameters will only appear in the parameter screens if the options are installed.

#### 4.3.1. Description of Test Parameters

##### Description of Test Parameters

**Voltage:** The Voltage that is applied to the High Voltage and Return terminals or the Cont. Check and Return terminals during a test.

**Max Lmt:** A maximum current or resistance threshold that when exceeded triggers a failure. A “T” or an “R” designator is shown in AC withstand parameters and means, “T” total current or “R” real current.

**Min Lmt:** A minimum current or resistance threshold that when not exceeded triggers a failure. A “T” or an “R” designator is shown in AC withstand parameters and means, “T” total current or “R” real current.

**Ramp Up:** A length of time that is allowed for the test voltage to climb from 0 to the voltage set point.

**Dwell:** A length of time that is allowed for the set point voltage to be applied.

**Delay:** A length of time that the set point voltage is applied but no judgment of the set parameters is made. A judgment of the parameters is not made until the end of the delay time.

**Ramp DN:** A length of time that is allowed for the test voltage to decay from set point to 0.

**Arc Sense:** During Hipot testing some low current arcing may be allowable. Arc sense is a maximum allowable threshold for arcing.

The numbers corresponding to the different arc sensitivity levels are 0 through 9, 1 meaning the maximum threshold of allowable arcing, 9 meaning the minimum threshold of allowable arcing and 0=OFF.

**Frequency:** This parameter is available in AC tests only and is selectable between 50 and 60Hz.

**Continuity:** This function checks for a connection between the cont. check and return lead.

**Connect:** This function when turned ON will connect or link the current step to the next step. When step 30 connect is turned "ON", it will be linked to the first step of the next memory. For example, memory 1, step 30 will be connected to memory 2, step 1. It is possible to connect all 1500 steps together when the connect parameter of all steps has been turned "ON".

**Scanner or EX Scanner:** (This parameter will only be seen on units equipped with a scanner). This multiple parameter allows for set up of the scanner channels. The three different selectable scanner states are L (scanner channel set to the return point), H (scanner set to the high voltage point) and O (OFF).

### 4.3.2. AC Withstand, Models 7620 and 7650

From the Test Parameter review screen, scroll the highlighted area to the Test Type and press the “Edit” soft key.

The Test Parameter edit screen will now be displayed. Now press the “Change” soft key until the letters ACW appear in the parameter field. Press the ENTER key to select the ACW test. The AC Withstand parameter-review screen will appear as follows:

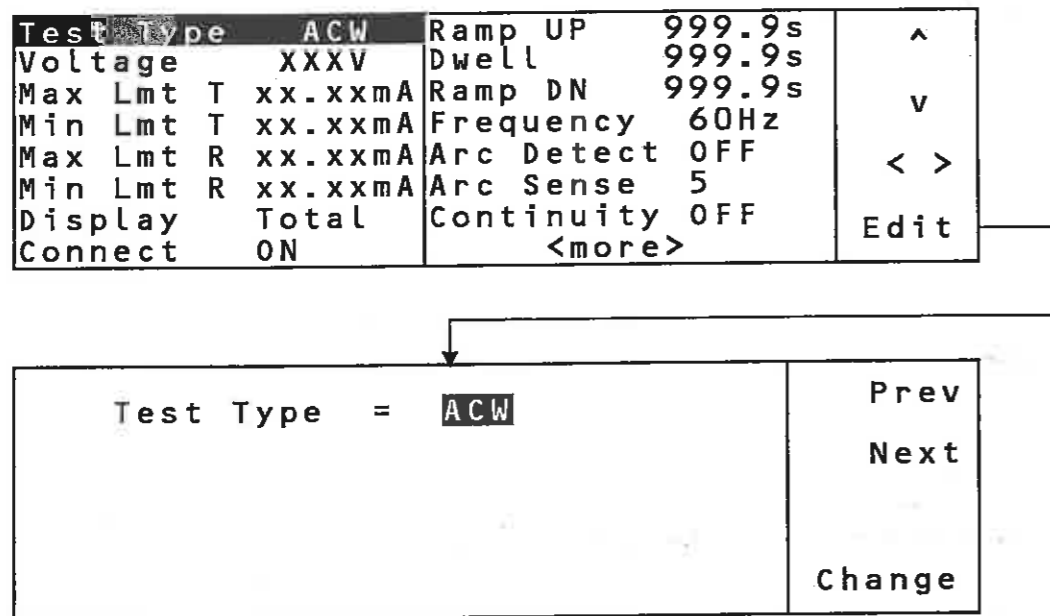

The second or <more> screen will only appear if there is a scanner selection in the menu. The Scanner selections will only appear if there is a scanner installed or an external scanner connected to the instrument. This is an auto detect feature in hardware.

From the AC Withstand setting screen the following parameters may be selected for editing: Voltage, Max-Lmt T, Min-Lmt T, Max-Lmt R, Min-Lmt R, Display Total/Real, Connect, Ramp Up, Dwell Time, Ramp Down, Frequency, Arc Detect (ON/OFF), Arc Sense, Continuity selection (DC continuity or OFF), Prompt and Scanner Channel selections (if there is a scanner installed).

#### Real Current

The AC Real Current function allows the user to monitor only the real portion of the leakage current and ignore any reactive components due to capacitance in the device under test. It is important to recognize that the total current is the vector sum of the reactive and real current, not the direct addition of the two components. As in a right triangle, the total current is the square root of the sum of the squares of the real and reactive currents.

Since the real component is usually much smaller than the reactive current, a doubling of the real current increases the total current by only a small amount. Unless the two components are

separated, a doubling of the real leakage current can go virtually undetected by a total current measurement.

Because Real Current is installed in HypotULTRA III, additional parameter selections are added to the ACW test parameters. The additional test parameters are Max Lmt R (Real Current Maximum limit), Min Lmt R(Real Current Minimum Limit) and Display. The standard total current limits have a "T" next to them indicating total current.

The AC Real Current function allows the operator to view both real and total current simultaneously. The Display parameter allows you to select which meter will display the real and total current. When the display parameter is set for Total, the large current meter will display the total current and the real current will be displayed in the small current meter below the Memory name. The opposite is true when the display parameter is set for Real.

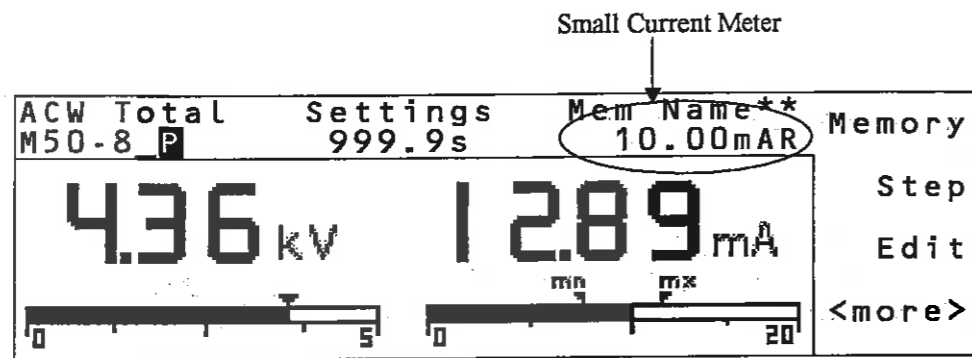

#### 4.3.3. DC Withstand, Model 7650 Only

From the Test Parameter-review screen, scroll the highlighted area to the Test Type and press the "Edit" soft key.

The Test Parameter edit screen will now be displayed. Now press the "Change" soft key until the letters DCW appear in the parameter field. Press the ENTER key to select the DCW test. The DC Withstand parameter-review screen will appear as follows:

Test Type	DCW	Ramp HI	OFF	^
Voltage	XXXXV	Charge LO	XXX.XuA	
Max Lmt	xxxxxuA	Arc Detect	OFF	v
Min Lmt	x.xuA	Arc Sense	5	
Ramp UP	999.9s	Continuity	OFF	< >
Dwell	999.9s	Scanner	HLHLHLHL	
Ramp DN	999.9s	Ex Scan	HLLLHLLH	Edit
Connect	ON	Prompt	xxxxxxx	

The Scanner selections will only appear if there is a scanner installed or an external scanner connected to the instrument. This is an auto detect feature in hardware.

From the DC Withstand parameter review screen the following parameters may be selected for editing: Voltage, Max-Lmt, Min-Lmt, Ramp Up, Dwell Time, Ramp Down, Connect, Ramp-

HI, Charge LO, Arc Detect (ON/OFF), Arc Sense, Continuity selection (DC continuity or OFF), Scanner Channel selections if installed, and Prompt.

### Ramp-HI

The Ramp-HI function is active during the Ramp period only. Ramp-HI will allow current higher than the normal Max-Lmt current setting of the DC Withstand Voltage test to avoid false failure due to charging current.

### Charge-LO

The Charge-LO function is used to check if the cables are connected properly at the beginning of a test. A capacitive DUT will draw charging current on the DC Withstand Voltage test when the Output is activated. If the charging current is lower than the setting, the test cables may not be connected properly. The instrument can set the Charge-LO parameter manually or automatically. To manually set the Charge-LO current, use the up and down arrow keys or the ENTER key and scroll the highlighted area to the Charge-LO current parameter. Enter the new Charge-LO current via the numeric keypad and then press the ENTER key to accept the new parameter or press the EXIT key to escape from the edit. To automatically set the Charge-LO current, use the up and down arrow keys or the ENTER key and scroll the highlighted area to the Charge-LO current parameter. Set the voltage and ramp times to the values that will be used on the DUT and connect the test cables or test fixture between the instrument and DUT. Press the test button.

**WARNING** Please be aware that the program will activate high voltage on the output connector while the Test button is pressed.

The program will read the charging current of DUT and set the Charge-LO current at approximately one half (1/2) of the reading. The instrument will beep and the new value will automatically be updated in the field and does not allow an escape to the original value or require that the ENTER key be used to accept the new parameter.

#### 4.3.4. Insulation Resistance, Model 7650 Only

From the Test Parameter-review screen, scroll the highlighted area to the Test Type and press the "Edit" soft key.

The Test Parameter edit screen will now be displayed. Now press the "Change" soft key until the letters IR appear in the parameter field. Press the ENTER key to select the IR test. The IR parameter-review screen will appear as follows:

Test Type	IR	Charge LO	X.XXXuA	^
Voltage	XXXXV	Scanner	HLHLHLHL	
Max Lmt	xxxxxMΩ	Ex Scan	HLLLHLLH	v
Min Lmt	xxxxxMΩ	Prompt	xxxxxxx	< >
Ramp UP	999.9s			
Delay	999.9s			
Ramp DN	999.9s			
Connect	ON			Edit

The Scanner selections will only appear if there is a scanner installed or an external scanner connected to the instrument. This is an auto detect feature in hardware.

From the Insulation Resistance parameter review screen, the following parameters may be selected for editing: Voltage, Max-Lmt, Min-Lmt, Ramp Up, Delay Time, Ramp Down, Connect, Charge-LO, Scanner Channel Output Select if installed and Prompt.

#### Charge-LO

The Charge-LO function is used to check if the cables are connected properly at the beginning of a test. A capacitive DUT will draw charging current on the DC Withstand Voltage test when the Output is activated. If the charging current is lower than the setting, the test cables may not be connected properly. The instrument can set the Charge-LO parameter manually or automatically. To manually set the Charge-LO current, use the up and down arrow keys or the ENTER key and scroll the highlighted area to the Charge-LO current parameter. Enter the new Charge-LO current via the numeric keypad and then press the ENTER key to accept the new parameter or press the EXIT key to escape from the edit. To automatically set the Charge-LO current, use the up and down arrow keys or the ENTER key and scroll the highlighted area to the Charge-LO current parameter. Make sure that the voltage and ramp times are set to the values that will be used on the DUT and connect the test cables or test fixture between the instrument and DUT. Press the test button.

**WARNING** Please be aware that the program will activate high voltage on the output connector while the Test button is pressed.

The program will read the charging current of DUT and set the Charge-LO current at approximately one half (1/2) of the reading. The instrument will beep and the new value will automatically be updated in the field and does not allow an escape to the original value or require that the ENTER key be used to accept the new parameter.



#### 4.3.5. Continuity, Model 7620 and 7650

Continuity test is generally used to test the ground conductor of a line cord. If the resistance exceeds Max-Lmt trip point or drops below the Min-Lmt trip point the HypotULTRA III will signal a continuity failure. If you are testing products with two prong plugs, do not activate the continuity circuit.

From the Test Parameter-review screen, scroll the highlighted area to the Test Type and press the “Edit” soft key.

The Test Parameter edit screen will now be displayed. Now press the “Change” soft key until the letters CONT appear in the parameter field. Press the ENTER key to select the CONT test. The CONT parameter-review screen will appear as follows:

Test Type	CONT	Scanner	HLHLHLHL	^
Max Lmt	xx.xxΩ	Ex Scan	HLLLHLLH	v
Min Lmt	xx.xxΩ	Prompt	xxxxxxx	< >
Dwell	999.9s			Edit
Offset	x.xxΩ			
Connect	ON			

The Scanner selections will only appear if there is a scanner installed or an external scanner connected to the instrument. This is an auto detect feature in hardware.

From the Continuity parameter setting screen, the following parameters may be controlled: Max-Lmt, Min-Lmt, Dwell, Offset, Connect, Scanner Channel Output Select if installed, and Prompt.

#### Offset

This function allows the instrument to compensate for lead and test fixture resistance during a continuity test. Using the up and down arrow keys or the ENTER key, scroll the highlighted area to the Offset parameter. You may now manually or automatically set the Offset value.

To manually set an Offset value enter a milliohm value via the numeric keypad and then press the ENTER key to accept the new value or press the EXIT key to escape from the edit.

To automatically set an Offset value, set the output voltage, current, and frequency to the values that will be used on the DUT and connect the test cables, test fixture, or scanner channel with fixturing to the instrument. Next, short the ends of the test cables and press the “TEST” button. The instrument will beep and the new value will automatically be updated in the field and does not allow an escape to the original value or require that the ENTER key be used to accept the new parameter.

#### 4.3.6. Default Parameters

Each of the test types (AC withstand, DC withstand and IR) have specific default test parameters that automatically load when test type is selected from the parameter edit screen. The following table is a listing of the Default Parameters for each of the different types of tests that are available in the HypotULTRA III. The Default Parameters are as follows:

##### Default Parameters.

Test Type	Parameter	Value
ACW	Voltage	1240V
	Max Lmt T	10.00mA
	Min Lmt T	0.000mA
	Max Lmt R	10.00mA
	Min Lmt R	0.000mA
	Display	Total
	Ramp UP	0.1s
	Dwell	1.0s
	Ramp DN	0.0s
	Connect	OFF
	Frequency	60Hz
	Arc Detect	OFF
	Arc Sense	5
	Continuity	OFF
	Scanner	00000000
Prompt		
DCW 7650 only	Voltage	1500V
	Max Lmt	10000uA
	Min Lmt	0.0uA
	Ramp UP	0.1s
	Dwell Time	1.0s
	Ramp DN	0.0s
	Connect	OFF
	Ramp-HI	OFF
	Charge-LO	0.0uA
	Arc Detect	OFF
	Arc Sense	5
	Continuity	OFF
	Scanner	00000000
	Prompt	
	IR 7650 only	Voltage
Max Lmt		0.00M $\Omega$
Min Lmt		0.05M $\Omega$
Ramp UP		0.1s
Delay		1.0s
Ramp DN		0.0s
Connect		OFF

Test Type	Parameter	Value
	Charge-LO	0.000uA
	Scanner	00000000
	Prompt	
CONT.	Max-Lmt	10.00Ω
	Min-Lmt	0.00Ω
	Dwell	1.0s
	Offset	0.00Ω
	Connect	OFF
	Scanner	00000000

#### 4.4. Memory, Step, and Default System Parameter Initialization

**Warning** Initializing the instrument will overwrite all memories and steps with ACW default parameters!

Press the 0 and 1 numeric keys and power the instrument at the same time, then press the soft key next to the word "Yes". All memories and steps will be loaded with the ACW default parameters and the System parameters will be set to the factory defaults. The default system parameters are as follows:

Setup Sys.	PLC Remote	OFF
	Single Step	OFF
	Fail Stop	ON
	Alarm	5
	Contrast	5
	Results	Last
	Lock	OFF
	Mem Lock	ON
	Address (GPIB only)	8
	Smart GFI	ON
	Results	Last
	Cal Alert	ON
	Date	mdy

The following System parameters will not be affected by the system initialization:

Setup Sys.	Cal Date	No change
	Cal Due	No change
	Alert	No change
	Date	No chnage
	Time	No change
Security	Password	No change
	Security	No change

## 5. Operating Instructions

### 5.1. Instrument Connections

#### 5.1.1. Adapter Box Connections

The adapter box provides an easy way to connect a DUT to the HypotULTRA III that is terminated in a two or three-prong line cord. The following diagram shows how to connect the adapter box to the HypotULTRA III to the device under test.

#### Adapter Box Connections

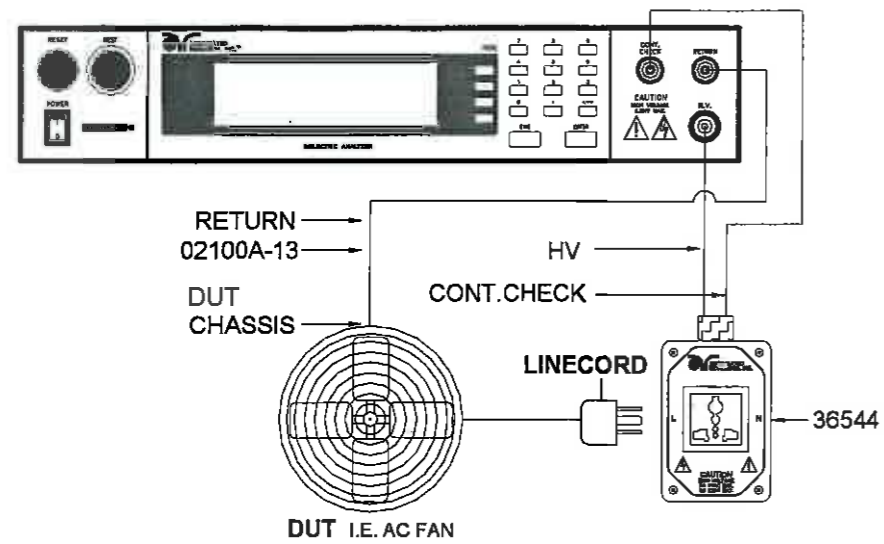

The rear output connections may be used for connecting the adapter box as well.

*L. Lestarge*

### 5.2. Perform Tests Screen

The HypotULTRA III automatically defaults to the Perform Tests screen upon power up. The Perform Tests screen will appear as follows:

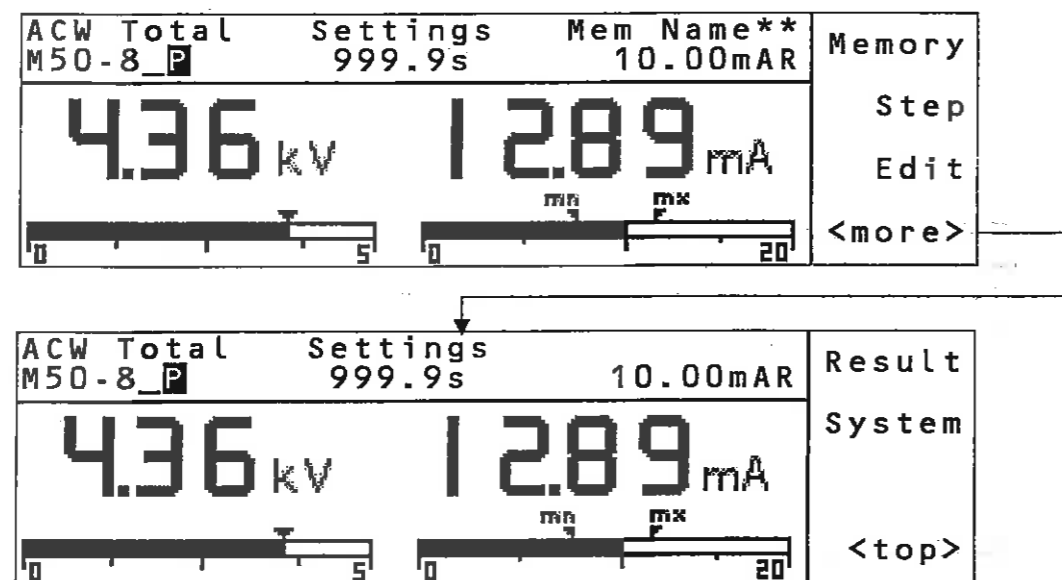

The Perform Tests screen is the main operational screen of instrument. From this screen, test parameters are monitored while the test is being performed.

The Perform Tests screen provides the Menus that allow access to all of the functions of the instrument. All system and test parameters may be accessed from the soft keys at these screens.

#### 5.2.1. Connected Step indicator

The connected step indicator is an under score symbol located directly next to the Memory and Step number and only will be displayed when the connect function has been turned "ON" in the Test parameters.

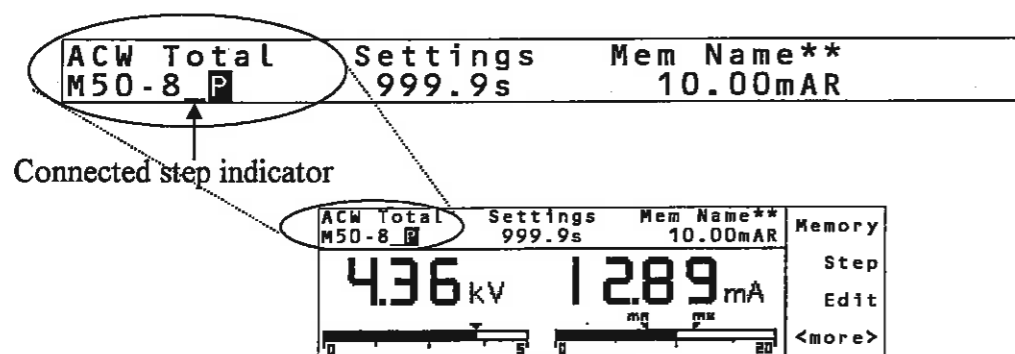

### 5.2.2. Analog Meters

A new feature unique to HypotULTRAI is analog bar graph meters. The bar graphs represent voltage and current and are located directly below their corresponding digital meter.

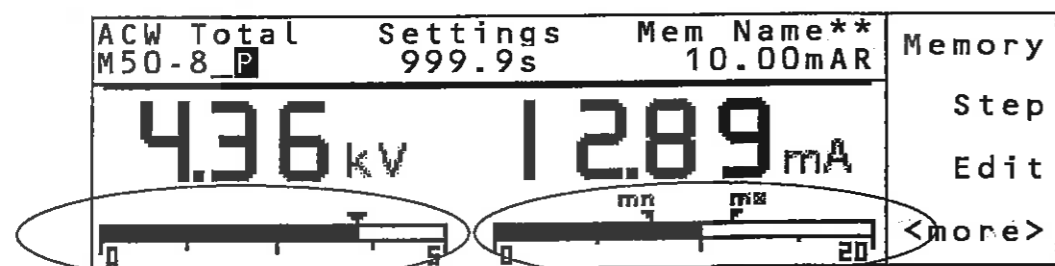

Analog Meters

Along with the bar graph display are arrows that point to voltage setting in the case of the analog voltmeter and the Min Lmt and Max Lmt settings in the case of the current meter.

### 5.2.3. Single Step

Single step is a function that allows you to run one step at a time from a sequence of tests. At the Perform Tests screen, use the up and down arrow keys or the ENTER key to scroll the highlighted area to the step you wish to perform. Press the TEST button and the instrument will initiate the single step and stop when finished without continuing to the next step. If you press Test again without first pressing Reset, the next step will initiate, run to completion and then stop. If a step fails and you wish to continue to the next step do not press Reset, if you press Reset it will return you to the original starting step.

You may single step through an entire sequence in this way as long as you do not press Reset. Once Reset is pressed, the instrument will return to the originally selected step.

To turn the Single Step function ON and OFF you must access the System parameters, please refer to section 4.1 Setup System.

### 5.2.4. Fail Stop

Fail Stop is a function that will stop a sequence of tests at the step if a failure occurs. If the fail stop is turned "ON" and a failure occurs (stopping the test), pressing the Test button again will start the test sequence at the next step. If a step fails and you wish to continue to the next step do not press Reset, if you press Reset it will return you to the original starting step. If this function is turned off the sequence of tests will continue to the end of the sequence regardless of whether or not a failure has occurred. If the Fail stop is off and a failure occurs during the test sequence, the RESET button will light and a short alarm will sound but the sequence will continue to the end. At the end of the test sequence, the RESET button will light and alarm will sound indicating failure during the sequence. Pressing the RESET button will silence the alarm and reset the instrument.

To turn the Single Step function ON and OFF you must access the System parameters, please refer to section 4.1 Setup System.

### 5.2.5. Results

At the end of a test sequence or single step test, you may review the measurements of each test by pressing "<more>" and then pressing "Results". The Results screen will appear as follow:

01-7	ACW	F		FAIL		^
01-8	DCW	P		Max Limit		
02-1	ACW	F	Settings	Results		v
02-2	DCW	F	1.00kV	1.00kV		
02-3	IR	F	10.00mAT	10.45mAT		
02-4	Cont	A	1.00mAT	1.00mAR		
			1.0S	1.0s		

Using the up and down arrow keys, scroll the highlighted area to the step results you wish to review. When the highlighted area is on the step you are reviewing, the test settings and results will appear on the right half of the display.

### 5.3. Perform Tests Metering

Each test performed by the HypotULTRA III contains a unique set of parameters and therefore requires specialized metering for each test. The following table describes what meters will be displayed for each of the different test types.

Test Type	Real Current	Total Current	Voltage	Time	Resistance
AC Withstand	X	X	X	X	NA
DC Withstand	NA	X	X	X	NA
IR	NA	NA	X	X	X
Continuity	NA	NA	NA	X	X

#### 5.3.1. Real Current Display

The AC Real Current function allows the operator to view both real and total current simultaneously. The Display parameter (refer to 4.3.2 AC Withstand parameter section of this manual) allows you to select which meter will display the real and total current. When the display parameter is set for Total, the large current meter will display the total current and the real current will be displayed in the small current meter below the Memory name. The opposite is true when the display parameter is set for Real.

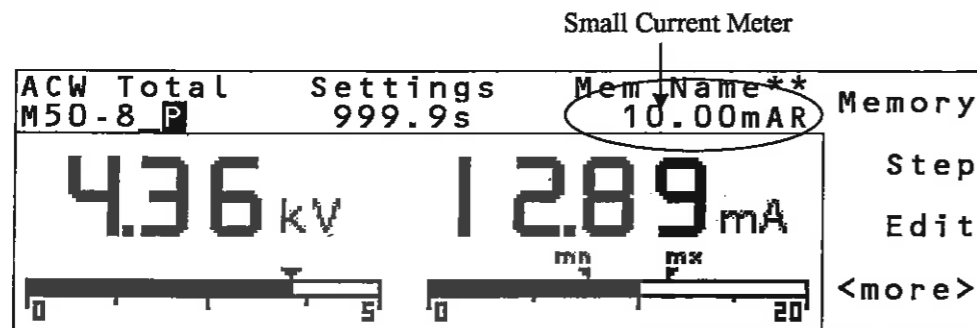

### 5.4. Performing a Test

1. As instructed in section 4.2., select a memory and step that is suitable for the test you would like to perform.
2. Attach the appropriate load or DUT to the instrument (refer to section 5.1 for instrument connections).
3. Press the TEST button.
4. The instrument will now perform the test or connected sequence of tests. If the Test is started from any other step than 01, when you push Reset or Test buttons, it will always return to the originally selected step.
5. If a prompt is embedded within a step, the test will pause at that step and display the prompt as a pop-up message. An example of a prompt will appear as follows:

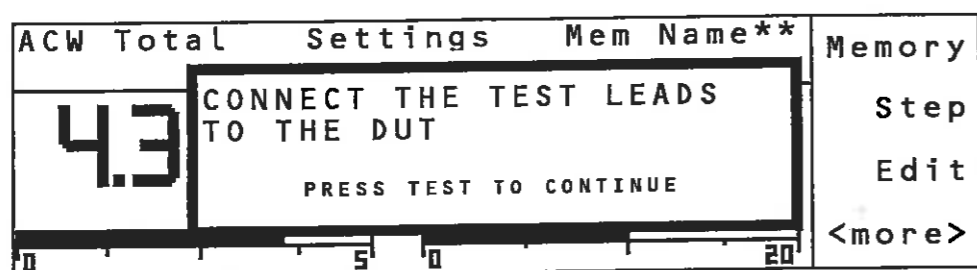

6. In order to clear the prompt and continue the test, push the Test button.
7. During a test, the appropriate metering will be display for the type of test that is being performed (Refer to section 5.3.). At the end of the test sequence, the top field of the display will indicate PASS if all the tests have completed successfully or indicate FAIL if any of the tests did not complete successfully.

#### 5.4.1. Manual Voltage Adjustment

The test voltage may be adjusted up and down during a test by pressing the “+ and -” soft keys.

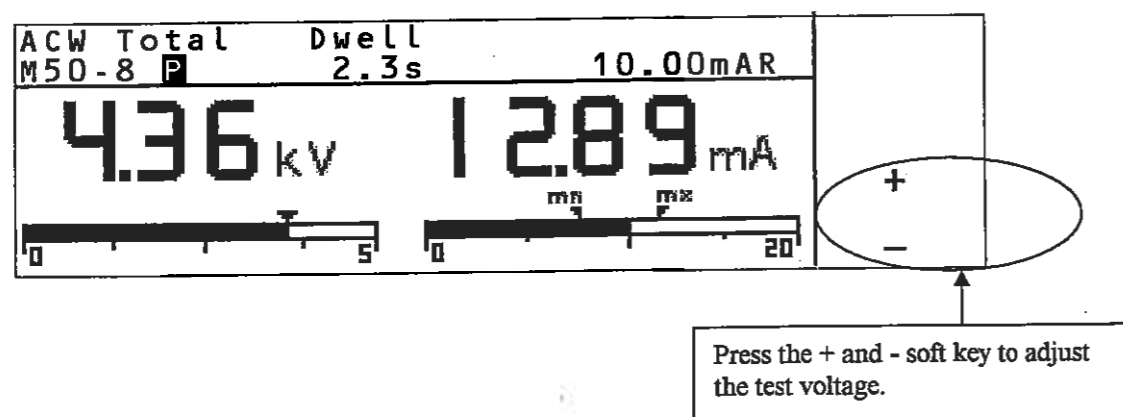

When the Lock parameter is selected “On” in the system menu, manual voltage adjustment is disabled. Therefore, you will not see the “+” and “-” symbols next to the bottom soft keys.



## 5.5. Displayed Messages

Directly above the Metering screens is the Test status display. This portion of the display is active during the test and allows you to view the type of test being performed and status of the test step. At the end of a test, the Test status display will inform you either that the test has passed or failed. The following is an example of the Test status display:

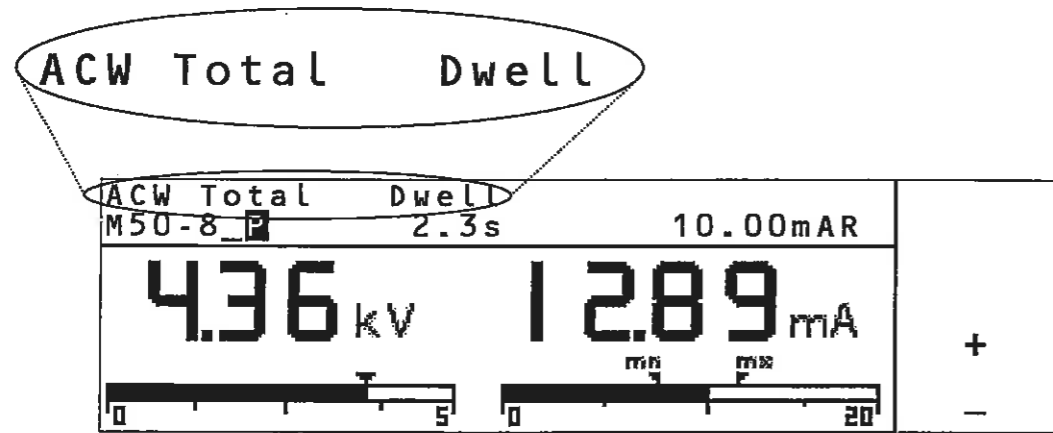

### 5.5.1. Test Status Messages

The following is a complete listing of the messages that appear in the Test status display and an explanation for each.

#### Dwell

This message appears on the display while a test is in process, the values update in real time.

#### Delay

This message appears on the display while a test is in process, the values update in real time.

#### Ramp Up

This message appears on the display at the beginning of the test, when the output voltage is ramping up.

#### Ramp Down

This message appears on the display at the end of the dwell cycle, when the output voltage is ramping down.

#### Pass

This message appears on the display when the test process is complete and the DUT passed the test.

**Abort**

This message appears on the display if the test in process is aborted with the RESET button or remote Reset control.

**Max-Lmt**

This message appears on the display if the DUT measurement exceeds the Max-Lmt setting of any parameter.

**Min-Lmt**

This message appears on the display if the DUT measurement drops below the Min-Lmt.

**CONT-Fail**

This message appears on the display if the DUT fails the basic continuity check performed during an AC/DC Withstand test (if Continuity is selected "ON").

**Arc-Fail**

This message appears on the display if the DUT arcing current exceeds the Arc Sense limit and Arc function is active (Arc Sense = 1...9) of the AC/DC Withstand test.

**Short**

This message appears on the display if the DUT current is well beyond the metering range of the test.

**Charge-LO**

This message appears on the display if the leakage current during Ramp-up falls below the Charge -LO setting.

**Breakdown**

This message appears on the display if the DUT current is well beyond the metering range of the test and the arcing condition beyond the arc sense limit.

**GND-Fault**

This message appears on the display if the GFI threshold is exceeded during the test.

### Output Error

This message appears on the display, if the instruments output reading does not match the setting. This message will only be seen if the EXIT key is press at the Output Error screen. If the instrument has an output problem when the TEST button is pressed, the Output Error screen will appear as follows:

```
          OUTPUT ERROR!  
The instrument has malfunctioned!  
  
      Setting: x.xxkV  
      Reading: x.xxkV  
  
Press EXIT to continue or call  
1-800-858-8378
```

The RESET button is not active in this situation. Only the EXIT key will allow you to return to the Perform Test screen.

### Fatal Error

If the instrument has a Fatal Error failure then the following screen will appear:

```
          FATAL ERROR 900X  
  
The instrument has malfunctioned!  
  
Please call 1-800-858-8378
```

All of the buttons and keys are not active in this situation. The customer should contact Associated Research, Inc to receive further instruction.

Fatal Error identification number will represent type of the failure that occurs.

**Error number of 9002** will appears on the display, if the instrument's System data or Model/Option/Serial Number data are corrupted and does not match the setting.

**Error number of 9003** will appears on the display, if the instrument's Calibration data is corrupted.

## 6. Instrument Verification

Verification is a process by which an instruments fail detectors are proven to be functioning properly and thereby “Verifying” the functionality of the electrical safety tester and connected accessories. Verification of failure detect circuitry of the electrical safety tester is required by safety agencies such as CSA, UL, and TÜV.

### 6.1. Verification Initialization

Turn on the POWER switch located on the lower left-hand side of the front panel. The initialization screen will appear with a message at the bottom indicating Press Test for Verification. You now have the option to press the TEST button and activate the Verification Menu (Refer to the section 6. Instrument Verification). The option to activate the Verification expires approximately 4 seconds after power-up. The Initialization screen will appear as follows:

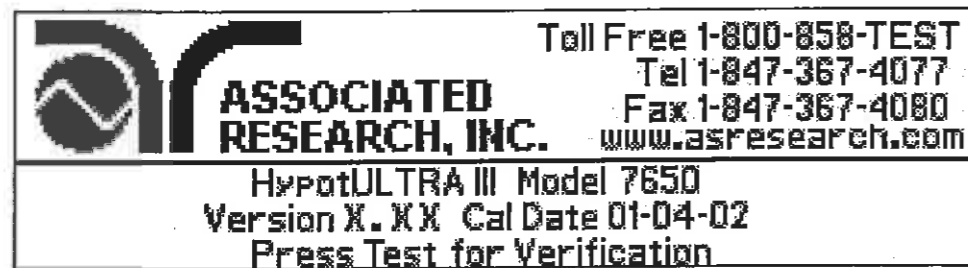

### 6.2. Verification Menu

From the Initialization screen (First start up screen), press the TEST button.

VERIFICATION	^
CONTINUITY	v
AC HIPOT	
DC HIPOT	
IR	
Choose mode then press Select. Press EXIT to cancel.	Select

The Verification Menu will now be displayed. If you have a Model 7650, four different Verification processes may be accessed; Continuity, AC Hipot, DC Hipot, and IR. If you have a Model 7620, two different Verification processes may be accessed; Continuity and AC Hipot.

### 6.2.1. Continuity Verification, Models 7620 and 7650

From the Verification screen, press the Up or Down arrow keys to select "Continuity", then press the "Select" soft key. An instructional prompt will now be displayed. The prompt will appear as follows:

```
CONTINUITY VERIFICATION

Open the DUT connection between Cont.
Check and Return. Unplug HV from the
Instrument.

Press TEST to begin Verification.
Press RESET to cancel.
```

Follow the instructions given in the prompt and then press TEST to begin the verification process.

At the end of the Verification process, a message will appear indicating the outcome of the process. If the instrument passes the Verification, (test failure, indicating the fail detectors are working properly) the RESET button will illuminate, the alarm will sound, and the following message will appear:

```
CONTINUITY VERIFICATION

VERIFICATION OK
Continuity failure detected.

Press RESET to clear message and return
to the Verification menu.
```

If the instrument fails the Verification (test pass, indicating the fail detectors are not working properly) the following message will appear:

```
CONTINUITY VERIFICATION

VERIFICATION ERROR
Continuity failure not detected.
Check leads or call 1-800-858-8378

To retest Continuity, press TEST.
Press RESET to cancel.
```

### 6.2.2. AC Hipot Verification, Models 7620 and 7650

From the Verification screen, press the Up or Down arrow keys to select "AC HIPOT", then press "Select" soft key. An instructional prompt will now be displayed. The prompt will appear as follows:

```
AC HIPOT VERIFICATION

Short the DUT connection between HV and
Return. Do not touch the leads during
the Test.

Press TEST to begin Verification.
Press RESET to cancel.
```

Follow the instructions given in the prompt and then press TEST to begin the verification process.

At the end of the Verification process, a message will appear indicating the outcome of the process. If the instrument passes the Verification, (test failure, indicating the fail detectors are working properly) the RESET button will illuminate, the alarm will sound, and the following message will appear:

```
AC HIPOT VERIFICATION

VERIFICATION OK
AC Hipot failure detected.

Press RESET to clear message and return
to the Verification menu.
```

If the instrument fails the Verification (test pass, indicating the fail detectors are not working properly) the following message will appear:

```
AC HIPOT VERIFICATION

VERIFICATION ERROR
AC Hipot failure not detected.
Check leads or call 1-800-858-8378

To retest AC Hipot, press TEST.
Press RESET to cancel.
```

### 6.2.3. DC Hipot Verification, Model 7650 Only

From the Verification screen, press the Up or Down arrow keys to select "DC HIPOT", then press "Select" soft key. An instructional prompt will now be displayed. The prompt will appear as follows:

```
DC HIPOT VERIFICATION
Short the DUT connection between HV and
Return. Do not touch the leads during
the Test.
Press TEST to begin Verification.
Press RESET to cancel.
```

Follow the instructions given in the prompt and then press TEST to begin the verification process.

At the end of the Verification process, a message will appear indicating the outcome of the process. If the instrument passes the Verification, (test failure, indicating the fail detectors are working properly) the RESET button will illuminate, the alarm will sound, and the following message will appear:

```
DC HIPOT VERIFICATION
VERIFICATION OK
DC Hipot failure detected.
Press RESET to clear message and return
to the Verification menu.
```

If the instrument fails the Verification (test pass, indicating the fail detectors are not working properly) the following message will appear:

```
DC HIPOT VERIFICATION
VERIFICATION ERROR
DC Hipot failure not detected.
Check leads or call 1-800-858-8378
To retest DC Hipot, press TEST.
Press RESET to cancel.
```

#### 6.2.4. IR Verification, Models 7650 Only

From the Verification screen, press the Up or Down arrow keys to select "IR", then press "Select" soft key. An instructional prompt will now be displayed. The prompt will appear as follows:

```
IR VERIFICATION

Short the DUT connection between HV and
Return. Do not touch the leads during
the Test.

Press TEST to begin Verification.
Press RESET to cancel.
```

Follow the instructions given in the prompt and then press TEST to begin the verification process.

At the end of the Verification process, a message will appear indicating the outcome of the process. If the instrument passes the Verification, (test failure, indicating the fail detectors are working properly) the RESET button will illuminate, the alarm will sound, and the following message will appear:

```
IR VERIFICATION

VERIFICATION OK
IR failure detected.

Press RESET to clear message and return
to the Verification menu.
```

If the instrument fails the Verification (test pass, indicating the fail detectors are not working properly) the following message will appear:

```
IR VERIFICATION

VERIFICATION ERROR
IR failure not detected.
Check leads or call 1-800-858-8378

To retest IR, press TEST.
Press RESET to cancel.
```



## 7. Connection of Remote I/O

Two 9-pin "D" type connectors are mounted on the rear panel that provides REMOTE-INPUT-OUTPUT control and information. These connectors mate with standard 9 pin D-sub-miniature connector provided by the user. The output mates to a male (plug) connector while the input mates to a female (receptacle) connector. For best performance, a shielded cable should be used. To avoid ground loops the shield should not be grounded at both ends of the cable. Suggested AMP part numbers for interconnecting to the Remote I/O are shown below:

205204-4	PLUG SHELL WITH GROUND INDENTS
205203-3	RECEPTACLE SHELL
745254-7	CRIMP SNAP-IN PIN CONTACT (for plug)
745253-7	CRIMP SNAP-IN SOCKET CONTACT (for receptacle)
745171-1	SHIELDED CABLE CLAMP (for either plug or receptacle)
747784-3	JACKSCREW SET (2)

### Remote Interface Rear Panel:

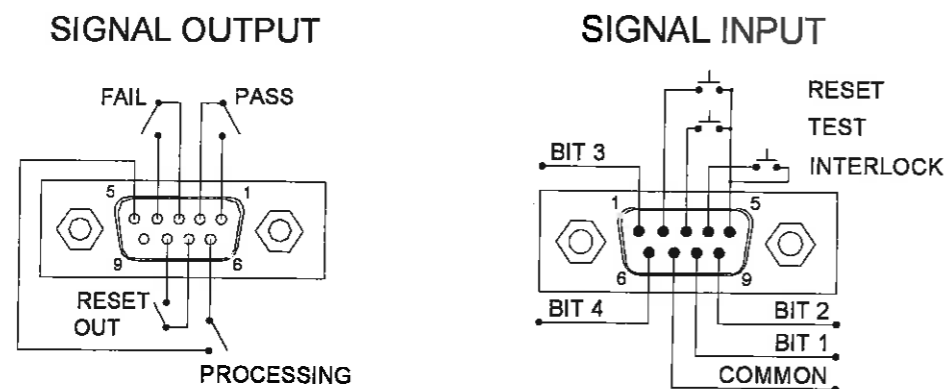

### 7.1. Signal Outputs on Remote I/O

The rear panel connector provides three output signals to remotely monitor PASS, FAIL, RESET, and PROCESSING conditions. The monitoring signals are provided by four normally open internal relays that switch on to indicate the current condition of the tester. These are normally open free contacts and will not provide any voltage or current. The ratings of the contacts are 1A / 125 VAC ( 0.5 ADC ). The signal outputs are provided on the 9-pin female D connector. Below is a listing that indicates what conditions activate each pin. When a terminal becomes active, the relay closes thereby allowing the external voltage to operate an external device.

- Pins 1 and 2 provide the PASS signal.
- Pins 3 and 4 provide the FAIL signal.
- Pins 5 and 6 provide the PROCESSING signal.
- Pins 7 and 8 provide the RESET signal.

The following describes how the relays operate for each test condition.

**PROCESSING** - The relay contact closes the connection between pin (5) and pin (6) while the instrument is performing a test. The connection is opened at the end of the test.

**PASS** - The relay contact closes the connection between pin (1) and pin (2) after detecting that the item under test passed all tests. The connection is opened when the next test is initiated or the reset function is activated.

**FAIL** - The relay contact closes the connection between pin (3) and pin (4) after detecting that the item under test failed. The connection will open when the next test is initiated or the reset function activated.

**RESET** - The relay contact closes the connection between pin (7) and pin (8) when the RESET button is pressed. The connection will close when the Reset button is pressed and will remain closed until the RESET button is released.

## 7.2. Signal Inputs of Remote I/O and Programmed Test Files

The HypotULTRA III remote connector enables remote operation of the TEST, RESET, and REMOTE INTERLOCK functions, and allows the operator to select one of 10 pre-programmed test files.

When the PLC Remote mode is on, the HypotULTRA III will respond to simple switch or relay contacts closures. A normally open momentary switch can be wired across pins 3 and 5 to allow remote operation of the TEST function. A minimum pulse width or contact closure of 20mS is required to guarantee a test start. A normally open momentary switch can be wired across pins 2 and 5 to allow remote operation of the RESET function. A minimum pulse width or contact closure of 50mS is required to guarantee that a running test will abort. When the PLC remote function is (ON) the TEST switch on the front panel will be disabled to prevent a test from being activated through this switch. For safety, the front panel RESET switch remains active even when a remote reset switch is connected so that high voltage can be shut down from either location.

The Remote File Select function gives the user the capability to quickly change parameters and initiate a test remotely. Ten pre-programmed test files can be accessed by connecting pins 1,6,8, and 9 to the common pin 7, in different combinations. The memory select bits should be set simultaneously and remain set for a minimum of 20ms to guarantee that the correct memory will be selected. However, the memory select bits may be set in sequential manner, provided that the time delay between each bit is less than 4ms. When the desired bit pattern has been established it should remain set for a minimum of 20ms to guarantee that the correct memory will be selected. The **Remote File Select Truth Table** (binary) shows the different combinations of momentary switch (relay) closures, and which memory programs that will be selected as the result. It may be necessary to "OR" the momentary switches (relay contacts) to prevent incorrect program selection due to timing errors.

REMOTE FILE SELECT TRUTH TABLE				
BIT 4	BIT 3	BIT 2	BIT 1	FILE #
0	0	0	1	01
0	0	1	0	02
0	0	1	1	03
0	1	0	0	04
0	1	0	1	05
0	1	1	0	06
0	1	1	1	07
1	0	0	0	08
1	0	0	1	09
1	0	1	0	10

1= Momentary Contact closure between BIT and COMMON  
0= No Contact closure between BIT and COMMON

**WARNING** Activating file program functions through the remote connector selects the file and starts the test that is pre-programmed into that file.

**CAUTION** Do not connect voltage or current to the signal inputs. Applying voltage to the signal input could result in damage to the control circuitry.

**Remote Interlock**

HypotULTRA III is equipped with a feature referred to as "Remote Interlock". Remote Interlock is a feature that utilizes a set of closed contacts to enable the instruments output. In other words, if the Interlock contacts open, the output of the instrument will be disabled. Remote Interlock could also be referred to as a remote system lockout, utilizing "Fail When Open" logic. If the Interlock contacts are open and the Test button is pushed, a pop-up message will be displayed on the screen for two seconds. The message will appear as follows:

**Interlock is Open**

If the Interlock contacts are opened during a test, the pop-up message will be displayed and the test will abort. The hardware has been configured to provide the interlock connections on pins 4 and 5 of the Remote Interface, Signal Input port. The instrument can still be used without the external interlock device as long as the Interlock Connector (38075 provided with unit) is plugged into the Remote Interface, Signal Input port. If there is nothing connected to the Remote Interface, Signal Input port to provide a connection to the interlock, the instrument will not perform tests.

**PLC Remote Pop-up message**

If you attempt to start a test from the front panel Test button and the PLC remote function is turned "ON", a pop-up message will be displayed. The pop-up message will appear as follows:

**PLC Remote ON**

## 8. Bus Remote Interface GPIB / RS-232

This section provides information on the proper use and configuration of bus remote interface. The RS-232 remote interface is standard on model 76XX but the GPIB (IEEE-488) interface option can be substituted for the RS-232 interface. Please refer to the Option section of this manual for details on the HypotULTRA III options. The RS-232 interface also uses the same command set as the GPIB interface for setting of test parameters. However, many functions of the GPIB 488.2 interface are not available through RS-232. The IEEE-488 interface included with HypotULTRA III conforms to the requirements of the IEEE-488.2 standard.

### 8.1. A Brief History of IEEE-488

Hewlett-Packard designed in 1965 the Hewlett-Packard Interface Bus (HP-IB) to connect their line of programmable instruments to computers. This bus had high transfer rates (nominally 1 Mbytes/s), and thus quickly gained acceptance. Later, it was accepted as the IEEE Standard 488-1975 and has then evolved into ANSI/IEEE Standard 488.1-1987. An enhancement to this standard was the IEEE standard 728-1982 and evolved into IEEE Std 488.2-1987. The new standard 488.2 was created and intended to be used with the existing 488.1 standard. The 488.2 standard defines issues related to standard codes, formats, protocols, and common commands.

IEEE-488 has expanded over the years and is used with many more types of computers and instruments than just HP. Because of this, it is usually referred to as the General Purpose Interface Bus, (GPIB).

### 8.2. GPIB Messages

There are typically two types of messages that GPIB devices use to communicate with other interconnected GPIB devices;

**Interface messages:** Often called commands or command messages and Device dependent messages often called data or data messages.

**Data Messages:** Contain information such as programming instructions or measurement results. Command Messages perform functions such as initializing the bus and addressing and unaddressing devices.

### 8.3. Functions

A GPIB device can be a Listener, Talker, and/or Controller. A Talker sends data messages to one or more Listeners, which receive data. A Controller manages the information flow on the GPIB by sending commands to all devices. The GPIB bus is much like a computer bus except a computer has circuit cards connected via a backplane and the GPIB has stand-alone devices connected via a cable.

### 8.4. Signals and Lines

The GPIB consists of 16 signal lines and 8 ground-return or shield drain lines. The 16 signal lines are grouped into 8 data lines, 3 handshake lines, and 5 interface management lines.

**Data Lines:** The eight data lines, DI01 through DI08 carry data and command messages. The 7-bit ASCII or ISO code set is used and the eighth bit DI08 is unused.

**Handshake Lines:** The transfer of message bytes between devices is done via three asynchronous control lines. Referred to as three-wire interlocked handshake. This guarantees that message bytes on the data lines are sent and received without transmission error.

**NRFD** (not ready for data) indicates when a device is ready or not ready to receive a message byte.

**NDAC** (not data accepted) indicates when a device has or has not accepted a message byte.

**DAV** (data valid) tells when the signals on the data lines are stable (valid) and can be accepted safely by devices.

**Interface Management Lines:** Five lines are used to manage the flow of information across the interface.

**ATN** (attention) ATN is driven true by the controller when it uses the data lines to send commands, and drivers ATN false when a Talker can send data messages.

**IFC** (interface clear) IFC is driven by the system controller to initialize the bus and become CIC.

**REN** (remote enable) The REN line is driven by the controller that is used to place devices in remote or local program mode.

**SRQ** (service request) The SRQ line can be driven by any device to asynchronously request service from the Controller.

**EOI** (end or identify) This line has two purposes- the Talker uses this line to mark the end of a message string, and the Controller uses it to tell devices to identify their response in a parallel poll.

### 8.5. GPIB Connector

Connection is usually accomplished with a 24-conductor cable with a plug on one end and a connector at the other end. Devices may be connected in a linear, star or a combination configuration.

The standard connector is the Amphenol or Cinch Series 57 Microribbon or AMP CHAMP type. The GPIB uses negative logic with standard transistor-transistor logic (TTL) levels. When DAV is true, for example, it is a TTL low level ( $\leq 0/8$  V), and when DAV is false, it is a TTL high level ( $\geq 2.0$  V).

#### Restrictions and Limitations on the GPIB

---

A maximum separation of 4 m between any two devices and an average separation of 2 m over the entire bus. A maximum total cable length of 20 m.

No more than 15 device loads connected to each bus, with no less than two-thirds powered on. For example 1 GPIB controller and a maximum of 14 GPIB instruments.

*Note:* A bus extender, which is available from numerous manufacturers, is available to overcome these limitations.

### 8.6. GPIB Address

This interface is optional on the HypotULTRA III. Each device on the GPIB (IEEE-488) interface must have a unique address. You can set the address of the HypotULTRA III to any value between 0 and 30. The address is set to 8 when the instrument is shipped from the factory. The address can only be set from the front panel. The address is stored in non-volatile memory and does not change when the power has been off or after a remote reset.

### 8.7. Interface Functions

The capability of a device connected to the bus is specified by its interface functions. These functions provide the means for a device to receive, process, and send messages over the bus. The interface functions are listed in the chart below.

#### GPIB 488.1 INTERFACE FUNCTIONS

Interface Function	Subset	Description
Source Handshake	SH1	Complete Source handshake capability
Acceptor Handshake	AH1	Complete Acceptor handshake capability
Talker	T6	Talker functions (unaddress if MLA)
Listener	L4	Listener functions (unaddress if MTA)
Service Request	SR1	Complete Service request capability
Remote Local	RL0	No remote/local capability
Parallel Poll	PP0	No parallel poll capability
Device Clear	DC1	Complete Device clear capability
Device Trigger	DT0	No device trigger capability
Controller	C0	No controller capability
Electrical Interface	E2	Three-state drivers

Controllable Items	Test and Reset control. Setting of test parameters for tests. Reading of instrument status and test results.
Data Codes	ASCII
Delimiter	NL (+ EOI)

## 8.8. RS-232 Interface

This interface is standard on HypotULTRA III. This interface provides all of the control commands and parameter setting commands of the GPIB interface with the exception of some of the 488.2 Common Commands and SRQ capability. All commands can be found in the command list, section 8.9.1 to 8.9.6 of this manual. The identification command \*IDN and the Status Reporting commands are also available through RS-232.

The RS-232 cabling should be configured as follows for a 9-pin serial port interface:

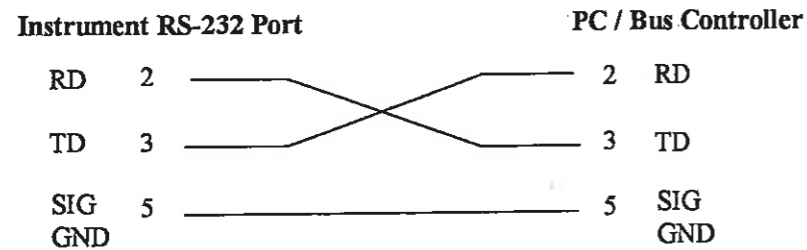

The COM port should have the following configuration. 9600 baud, 8 data bits, 1 stop bit, no parity. This interface does not support XON/XOFF protocol or any hardware handshaking. The controller should be configured to ignore the handshaking lines DTR (pin 4), DSR (pin 6) CTS (pin 8) and RTS (pin 7). If the port cannot be configured through software to ignore the lines then the handshake lines should be jumpered together in two different sets. Pins 4 and 6 jumpered together and pins 7 and 8 jumpered together at the controller end of the cable.

When sending command over the RS232 bus the instrument will send a response string of 06 hex or 6 decimal, the Acknowledge (ACK) ASCII control code if the transfer was recognized and completed by the instrument. If there is an error with the command string that is sent, the instrument will respond with 15 hex or 21 decimal, the Not Acknowledge (NAK) ASCII control code. The ACK or NAK response allows for software handshaking, to monitor and control data flow. When requesting data from the instrument, it will automatically send the data back to the controller input buffer. The controller input buffer will accumulate data being sent from the instrument including the ACK and NAK response strings, until it has been read by the controller.

## 8.9. GPIB / RS-232 Interface Command List

A GPIB read command must be sent after the command strings, to retrieve any data from a query command (?). The HypotULTRA III GPIB bus will not send any data to the controller without being queried. The RS-232 bus will automatically send any response back to the controller's input buffer. Each command string should be terminated by the ASCII control code, New Line <NL>, OAh or the end of line EOL message for GPIB.

The following conventions are used to describe the commands syntax for HypotULTRA III. Braces ( { } ) enclose each parameter for a command string. Triangle brackets ( < > ) indicate that you must substitute a value for the enclosed parameter. The Pipe ( | ) is used to separate different parameter options for a command. The command and the parameter data must be separated with a space.



All commands that end with a question mark (?) are query commands and required an IEEE-488 read command to retrieve the data from the device's output buffer.

### 8.9.1. Test Execution Commands

The following commands are used to control actual output voltage and current from the instrument. Please observe all safety precautions.

Command	Description
TEST	Execute a Test
RESET	Abort a test in Process or Reset Failures
SAO	Set Auto-Offset
SACG	Set Auto-Charge-LO

#### TEST

Starts the test sequence at the selected step loaded into memory (RAM).

#### RESET

Stop or abort a test. Also used to reset a latched failure condition.

#### SAO

Set the offset for the Continuity test. The cables and any test fixture should be connected before executing the command. This command will perform an actual test and all safety precautions should be observed when using this command.

#### SACG

Set the Charge-LO parameter for the DCW or IR test. The cables and any test fixture should be connected before executing the command. The test parameters that are set for the step will be used when performing the auto setting. This command will perform an actual test and all safety precautions should be observed when using this command.

### 8.9.2. File Editing Commands

The following commands are used to create or modify Test Setup Files.

Command	Description	Value
FL <memory number>	File Load	<i>memory number</i> = 1-50
FN <file name>	File Name	<i>file name</i> = Valid ASCII (1) maximum 11 characters
SS <step number>	Step Select step number	<i>step number</i> = 1-30
SAA	Step Add ACW test	
SAD	Step Add DCW test	
SAI	Step Add IR test	

Command	Description	Value
SAC	Step Add CONT test	
ADD <test,p1,p2,p3...>	Add all parameters of a test	
SP <prompt message>	Step Prompt Create	prompt message = Valid ASCII (1) maximum 32 characters
SP	Step Prompt Delete	
SF {1 0}	Step Fail Stop	1=On, 0=Off

(1) "Valid ASCII" is the character set that is available from the front panel LCD user interface. Consisting of upper case alphabet (A-Z), numbers (0-9) and decimal point (.), asterisk (\*), dash (-), under bar ( \_ ), tilde (~) and space (SP).

#### FL <memory number>

Load a file by memory number from non-volatile memory into random access memory RAM.

#### FN < file name>

Creates a new file name for the active memory loaded into RAM.

#### SS <step number>

Selects the active selected step to load into RAM. The step must first be selected before any specific parameters can be edited.

#### SAA, SAD, SAI, SAC

These commands add the appropriate test type within the memory at the step location that has been selected. The parameters of the previous test type will be deleted and the default values for the new test type will be recalled. If the same test type is selected that already exists, the default values will replace the previous parameters.

#### ADD <test,p1,p2,p3...>

This command edits all parameters in a step. Parameters will be edited at the step location that has been selected. See the command summary tables to see the specific test type for each of these commands

The parameter <test> indicated the test type. The values ACW, DCW, IR, or CONT must be used. The parameters <p1,p2> etc. indicate the individual settings for each test. All parameters must be included with the command and should appear in the same order that is shown in the table below. Also, like the individual parameter editing commands, the unit should not be included with the value. Only the numeric value should be included in the command string. When the scanners are being used they should be appended to the end of the string, with the internal scanner first if installed, followed by the external scanner if connected the rear panel scanner control port. The list of parameters can also be found in the default parameters section of the manual, or refer to the Test Parameter Editing commands section for the proper values.

The parameter values should use complete text and not use the coded values that are associated with the individual parameter setting commands such as "ON" and "OFF" for toggle field or words such as "Real" or "Total". The LS? companion command will also list all parameters in complete text in the order as they appear in the following table, preceded by the step number.

	ACW	DCW	IR	CONT
1	Voltage	Voltage	Voltage	Max-Limit
2	Max-Lmt T	Max-Lmt	Max-Lmt	Min-Lmt
3	Min-Limit T	Min-Limit	Min-Limit	Dwell
4	Ramp Up	Ramp Up	Ramp Up	Offset
5	Dwell Time	Dwell Time	Delay Time	Connect
6	Ramp Down	Ramp Down	Ramp Down	Internal Scanner (opt)
7	Arc Sense	Charge-LO	Charge-LO	External Scanner
8	Max-Lmt Real	Arc Sense	Connect	
9	Min-Lmt Real	Ramp-HI (ON/OFF)	Internal Scanner (opt)	
10	Frequency (50/60)	Arc Detect (ON/OFF)	External Scanner	
11	Arc Detect (ON/OFF)	Continuity (ON/OFF)		
12	Continuity (ON/OFF)	Connect		
13	Display (Real/Total)	Internal Scanner (opt)		
14	Connect	External Scanner		
15	Internal Scanner (opt)			
16	External Scanner			

**SP <prompt message>**

Adds or edits a prompt message for the active step.

**SP**

Removes or deletes the prompt that had been created for the active step.

**8.9.3. Test Parameter Editing Commands and Companion Queries**

These commands are used to modify the test parameter within each step. These commands require a parameter value to be included with the command. The companion query command will read the parameter. The writing of the parameter requires that the unit not be included with the value, only the numeric value should be included with the command. Also, when the query commands are used the response will not include the unit's characters. Many of the commands will function the same way for multiple test types; however, the input range may be different and therefore used a different possible set of values.

Command	Name	Test Types	Value
ECC {1 0} ECC?	Edit Connect	ALL	1= On, 0=Off
ED {1 0} ED?	Edit Current Meter Display	ACW	1 = Real, 0 = Total
EV <value> EV?	Edit Voltage	ACW DCW IR	0 - 5000V 0 - 5000V 50 - 1000V
ECG < value > ECG?	Edit Charge-Lo	DCW IR	0.0 - 350.0uA 0.000 - 3.500uA
ECT {1 0} ECT?	Edit Continuity	ACW DCW	1= On, 0=Off
ERU < value > ERU?	Edit Ramp-Up	ACW DCW IR	0.1 - 999.9s
ERD <value > ERD?	Edit Ramp-Down	ACW DCW IR	0.0 - 999.9s 0, 1.0 - 999.9s 0, 1.0 - 999.9s
ERH {1 0} ERH?	Edit Ramp-HI	DCW	1= On, 0=Off
EDW < value > EDW?	Edit Dwell	ACW DCW CONT	0, 0.4 - 999.9s 0, 0.4 - 999.9s 0, 0.3 - 999.9s
EDE < value > EDE?	Edit Delay	IR	0, 1.0 - 999.9s
EO < value > EO?	Edit Offset	CONT	0.00 - 10.00Ω
EA < value > EA?	Edit Arc	ACW DCW	1 - 9
EAD {1 0} EAD?	Edit Arc-Detect	ACW DCW	1= On, 0=Off
EHT < value > EHT?	Edit Max-Lmt-T	ACW	0.000 - 30.00mA
EHR < value > EHR?	Edit Max-Lmt-R	ACW	0.000 - 30.00mA
EH < value > EH?	Edit Max-Lmt	DCW IR CONT	0.0 - 10000uA 0, 0.05 - 50000MΩ 0, 0.00 - 2000Ω
ELT < value > ELT?	Edit Min-Lmt-T	ACW	0.000 - 30.00mA
ELR < value > ELR?	Edit Min-Limit-R	ACW	0.000 - 30.00mA

Command	Name	Test Types	Value
EL < value > EL?	Edit Min-Lmt	DCW IR CONT	0.0 - 10000uA 0.05 - 50000MΩ 0.0 - 2000 Ω
EF {1 0} EF?	Edit Frequency	ACW	1=60Hz, 0=50Hz
EIS <scanner string> EIS?	Edit Internal Scanner	ACW DCW IR CONT	scanner string = 1-16 element ASCII string consisting of H, L, or O. H=HV or Cont. , L=RETURN, O=OPEN
EES EES?	Edit External Scanner	ACW DCW IR CONT	scanner string = 1-16 element ASCII string consisting of H, L, or O. H=HV or Cont., L=RETURN, O=OPEN

#### 8.9.4. System Parameter Editing Commands and Companion Queries

These commands are used to modify the system parameters for the instrument. These commands require a parameter value to be included with the command. The companion query command will read the parameter using the same value that is used for setting the parameter.

Command	Name	Value
SPR {1 0} SPR?	PLC Remote	1= On, 0=Off
SSI {1 0} SSI?	Single Step	1= On, 0=Off
SF {1 0} SF?	Fail Stop	1= On, 0=Off
SAL < value > SAL?	Alarm Volume	0-9
SC < value > SC?	Contrast	1-9
SL {1 0} SL?	Lock	1= On, 0=Off
SML {1 0} SML?	Memory Lock	1= On, 0=Off
SSG {1 0} SSG?	Smart GFI	1= On, 0=Off
SR {2 1 0} SR?	Results	0=ALL, 1=P/F, 2=LAST
SCA {1 0}	Cal Alert	1= On, 0=Off

Command	Name	Value
SCA?		
SCDA < value > SCDA?	Cal Date	mm,dd,yy or yy,mm,dd or dd,mm,yy according to SDF setting
SCDU < value > SCDU?	Cal Due	mm,dd,yy or yy,mm,dd or dd,mm,yy according to SDF setting
SA < value > SA?	Alert Date	mm,dd,yy or yy,mm,dd or dd,mm,yy according to SDF setting
SD < value > SD?	Date	mm,dd,yy or yy,mm,dd or dd,mm,yy according to SDF setting
SDF < value > SDF?	Date Format	0=yy,mm,dd, 1=mm,dd,yy, 2=dd,mm,yy
ST < value > ST?	Time	hh,mm (24hr) hh,mm,AM or hh,mm,PM (12hr) according to STF setting
STF {1 0} STF?	Time Format	0=12hr, 1=24hr
SD1 < value > SD1?	Device ID	0 - 9999999
SD2 {1 0} SD2?	Device ID	1= On, 0=Off
SPM {2 1 0} SPM?	Print Mode	0=AUTO, 1=MANUAL, 2=OFF
SPRE {1 0} SPRE?	Prn Result n	1=FAIL, 0=ALL
SPS {1 0} SPS?	Prn Setting n	1= On, 0=Off
SFF {1 0} SFF?	Form Feed n	1= On, 0=Off

### 8.9.5. Query Commands

These query commands will retrieve data from the instrument. The GPIB bus application requires an IEEE-488 read command to be sent after the query command. These commands include functions for retrieving test data, test results and remote hardware status as well as setup file information.

Command	Name	Value
TD?	List Testing Data	Test In Process
RD <step number>?	List Results Data	<i>step number</i> = 1-30
RR?	Read Remote Reset	1=Open, 0=Closed
RI?	Read Remote Interlock	1=Open, 0=Closed
RS?	Read Scanner Status	0 = None, 1 = Internal 2 = External, 3 = Both

Command	Name	Value
LF?	List File Name	Active selected memory
LFN?	List Memory (File) Number	Active selected memory
LF <memory number>?	List File Name by memory number	<i>memory number = 1-50</i>
LP?	List Prompt	Active selected Step
LP <step number>?	List Prompt by step number	<i>step number = 1-30</i>
LS?	List Step Parameters	
LS <step number>?	List Step Parameters by step number	<i>step number = 1-30</i>

#### TD?

Read the active data being displayed on the LCD display while the test is in process. Will also read the last data taken when the test sequence has completed. Each parameter is separated by commas and includes step number, test type, test status, and metering. The syntax for this command response is {step, test type, status, meter 1, meter 2, meter 3}. ACW test displays 4 meters. Each meter will contain only the value and not the units. In the case of DCW current where both uA and mA are used on the display, the command response will always indicate the current in uA for example 2.0mA will respond with 2000 for 2000uA.

#### RD <step number>?

Read the results for an individual step. The step number is the actual step number that has been saved within the file, not the order of which the steps were executed. For example if the test was executed starting from step 3 and ending with step 5 then the first step test results will be found in location 3 not in location 1. Each parameter is separated by commas and includes step number, test type, test status, and metering. The syntax for this command response is {step, test type, status, meter 1, meter 2, meter 3}. ACW test displays 4 meters. Each meter will contain only the value and not the units. In the case of DCW current where both uA and mA are used on the display the command response will always indicate the current in uA for example 2.0mA will respond with 2000 for 2000uA.

#### RR?

Read the remote Reset input signal. When the remote reset has be activated by closing the contacts the query will return a value of 1 to indicate the instrument is being Reset.

#### RI?

Read the remote Interlock input signal. When the remote Interlock has be activated by opening the contacts the query will return a value of 0 to indicate the instrument is in the Interlock state and will not be able to generate output voltage or current.

**RS?**

Read Scanner Status command will respond with a value that identifies the number scanners installed or connected to the instrument. Values 0 – 4 will indicate if there are no scanners connected, one Internal or External scanner, or if both an Internal and an External scanner are connected.

**LF?**

Lists the file name of the memory loaded into active memory (RAM).

**LFN?**

Lists the memory number of the active memory file loaded into active memory (RAM).

**LF <memory number>?**

List the file name of any of the 50 memories.

**LP?**

Lists the prompt that is created for the individual step that has been selected within active memory (RAM).

**LP <step number>?**

Lists the prompt that has been created for of one of the steps of the file within active memory (RAM).

**LS?**

Lists all the Parameters for the individual step that is currently selected. See the ADD command for the list of parameters. A comma (,) will separate each parameter and will be preceded with the step number.

**LS <step number>?**

Lists all the Parameters for the individual step indicated by *step number* = 1-30. See the ADD command for the list of parameters. A comma (,) will separate each parameter and will be preceded with the step number.



### 8.9.6. IEEE 488.2 Common Commands

These commands are required by the IEEE-488.2 standard with the exception of \*PSC, \*PSC?. Most of these commands are not available over the RS-232 bus except for the \*IDN? command which can be used to retrieve the instrument identification information, and the four status reporting commands \*ESR?, \*ESE, \*ESE? and \*STB?

Command	Name	Description
*IDN?	Identification Query	Associated Research Inc., Model Number, Serial Number, Firmware Revision
*RST	Reset Command	Resets HYPOTULTRA III
*TST?	Self-Test Query	00H=OK 01H=TEST EEPROM ERROR
*CLS	Clear Status Command	Clear Standard Event Status Register Clear Service Request Register
*OPC	Operation Complete Command	When all selected pending operations complete, ESR BIT0=1
*OPC?	Operation Complete Query	When all selected pending operations complete, Output Queue=1
*WAI	Wait-to-Continue Command	
*PSC {1 0}	Power-on Status Clear Command	1 = Power-on clear enable registers 0 = Power-on load previous enable registers
*PSC?	Power-on Status Clear Query	
*ESR?	Standard Event Status Register Query	0 - 255
*ESE <value>	Standard Event Status Enable Command	value = 0 - 255
*ESE?	Standard Event Status Enable Query	0 - 255
*STB?	Read Status Byte Query	Read Status Byte
*SRE <value>	Service Request Enable Command	value = 0 - 255
*SRE?	Service Request Enable Query	0 - 255

#### \*IDN?

Read the instrument identification string. Company =Associated Research Inc.

#### \*RST

Reset the instrument to original power on configuration. Does not clear Enable register for Standard Summary Status or Standard Event Registers. Does not clear the output queue. Does not clear the power-on-status-clear flag.

#### \*TST?

Performs a self-test of the instrument data memory. Returns 0 if it is successful or 1 if the test fails.

**\*CLS**

Clears the Status Byte summary register and event registers. Does not clear the Enable registers.

**\*OPC**

Sets the operation complete bit (bit 0) in the Standard Event register after a command is completed successfully.

**\*OPC?**

Returns an ASCII "1" after the command is executed.

**\*WAI**

After the command is executed, it prevents the instrument from executing any further query or commands until the no-operation-pending flag is TRUE.

**\*PSC {1|0}**

Sets the power-on status clear bit. When set to 1 the Standard Event Enable register and Status Byte Enable registers will be cleared when power is turned ON. 0 setting indicates the Enable registers will be loaded with Enable register masks from non-volatile memory at power ON.

**\*PSC?**

Queries the power-on status clear setting. Returns 0 or 1.

**\*ESR?**

Queries the Standard Event register. Returns the decimal value of the binary-weighted sum of bits.

**\*ESE <value>**

Standard Event enable register controls which bits will be logically OR'd together to generate the Event Summary bit 5 (ESB) within the Status Byte.

**\*ESE?**

Queries the Standard Event enable register. Returns the decimal value of the binary-weighted sum of bits.

**\*STB?**

Read the Status Byte. Returns the decimal value of the binary-weighted sum of bits.

**\*SRE <value>**

Service Request enable register controls which bits from the Status Byte should be use to generate a service request when the bit value = 1.

**\*SRE?**

Queries the Service Request enable register. Returns the decimal value of binary-weighted sum of bits.

**8.9.7. Status Reporting**

Status reporting system is configured using two types of registers. An Event Register and a Summary register. The summary register is known as the Status Byte register and records high-level summary information acquired by the event registers.

An Event register report defined conditions or messages at each bit. The bits are latched and remain at an active state until the register is either Read or Cleared. Reading the event register automatically clears the register and sets all bits to inactive state or 0. When querying an event register the information is returned as a decimal number representing the binary-weighted sum of all bits within the register.

The Enable registers bits represent the selection of bits that will be logically-ORed together to form the summary bit in the status byte. The \*CLS command will not clear the enable registers and if you wish to clear the register you must set it to a value of 0. Like the event register, the enable register is represented as a decimal number that equals the binary-weighted sum of all bits.

The enable register will clear to value of 0 at power up unless the \*PSC 0 command had been executed before power-off. The \*PSC command tells the device whether or not it should clear the enable registers at power-on. Using this command will allow SQRs to function immediately after power-on.

		Standard Event Register		Status Byte Register	
Bit	Binary weight	Event Register	Enable Register	Summary Register	Enable Register
0	1	Operation Complete		ALL PASS	
1	2	not used		FAIL	
2	4	Query Error		ABORT	
3	8	Device Error		TEST IN PROCESS	
4	16	Execution Error		Message Available (MAV)	
5	32	Command Error		Event Summary Bit (ESB)	
6	64	not used		Request Service (RQS) or Master Summary Status (MSS)	not used
7	128	Power On		PROMPT	

\*ESR?

\*ESE  
\*ESE?

\*STB? | SPOLL

\*SRE  
\*SRE?

### 8.9.8. GPIB Service Request

The service request capability is not available with the RS-232 interface. The SRQ line will be activated only after one or more of the service request functions have been enabled using the Status Byte Enable Register command \*SRE.

The status byte bit assignments are as described in the previous section for status reporting. When the instrument has requested service, the enabled bit or bits and the RQS bit 6 will be active or 1. Bit 4, 5, and 7 are not used and will be set to false, or 0 for all status byte reads.

After the serial poll (SPOLL) is executed the RQS bit will be cleared to 0, and the remaining bits will remain unchanged. The status byte will not change value until the event register is read and cleared for the corresponding status byte bit.

For example after the All Pass SRQ has been enabled, when the test(s) have finished with pass indications the instrument will set the hardware SRQ line and output the status byte of 41 hex. This means that bit 6 and bit 0 are set to a value of 1. After reading the status byte the status byte value will change to 01 hex.

### 8.10. Example of Communicating Over the GPIB Bus

To write commands over the IEEE bus you must enter the code that is specific to the software language you are using. Then follow the example below:

To set the output voltage across the IEEE bus at 1240 volts do the following. First select the ACW step for example by sending the string for step one "SS 1" then send the string "EV 1240": This tells the instrument to set the AC voltage at 1240 volts. A string is a list of ASCII characters, octal or hex bytes or special symbols, enclosed in double quotes.

If the step has already been selected to ACW mode and you wish to set the Ramp Up time of the ACW test across the IEEE bus at 10 seconds, do the following, send the string "ERU 10.00". This tells the instrument to set the AC Ramp Up time at 10.00 seconds.

To set outputs 1 & 2 of the internal scanner to High, outputs 3 & 4 to Low and outputs 4-8 to Off type in the following string, "EIS HHLLOOOO", after the ACW Test Function has been selected. All channels not being specifically set will automatically be set to "O" open.

To read the live testing data, first send the string "TD?" then send the GPIB command to read. For RS-232 the response will be sent automatically to the controller. The instrument will send a string of parameters separated by commas for each meter on the display example the data for an ACW test might be as follows: "01,ACW,Dwell,3.00,1.25,0.00,2.5" this represents an ACW test at step 1, 3.00KV output voltage, 1.25mA total current, 0.00mA real current and the elapsed time for Dwell cycle is 2.5 seconds.

### **8.11. Non Volatile Memory**

The instrument saves each parameter in non-volatile memory when the parameters are sent to the instrument. The non-volatile memory has a limited write cycle life, therefore for programmers who wish to send all parameters before executing each test, should use Memory 50 step 30. The parameters will be stored in the CPU's Random Access Memory (RAM) until another memory location is selected. However, settings written to RAM from GPIB/RS-232 mode will be lost when power is shut down. Parameter changes to RAM are unlimited and will not affect the life of the internal non-volatile memory chip.

#### **FOR MORE INFORMATION ON IEEE (GPIB) PLEASE CONTACT**

The Institute of Electrical and Electronic Engineers, Inc.  
345 East 47th Street,  
New York, NY 10017  
☎ 1-212-705-7018 (Communications Society of IEEE)  
Internet: [www.ieee.org](http://www.ieee.org)

## 9. Options

### Introduction

This section contains a list and descriptions of available factory installed options at the time of this printing. The list of options contains an option code number that can be referenced on the data plate on the rear panel of the unit.

### Option Label

On the rear panel of the instrument, you will find a label that contains the option code.

For example, your options code would appear as follows:

Fitted with option 01 ..... OPT: 01  
 Fitted with option 01 and 08..... OPT: 0108

### HypotULTRA III Options

Option List

Code	Description
01	Internal 8 Channel Scanner with Continuity
02	Internal 4 Channel Scanner with Continuity
06	Dual Remote Test Switches
08	Printer Card
10	GPIB
14	3mA AC Output

#### 01 8 Channel Scanner with Continuity

The Scanner option provides 8 high voltage/continuity channels on the rear panel. The High Voltage/Continuity channels can be set to a High (Continuity) or Low level giving the capability to test from one channel to another channel or from any channel to a common Low or Return point. The channels can be connected in parallel if desired but there is only one leakage current measurement for all channels.

The scanner will provide output to multiple test points and will have the same operation specifications that apply to the standard instrument.

#### Setting up the scanner channels

1. From the Test parameter review screen (refer to section 4.2.4), scroll the highlighted area to the scanner parameter using the “< >, ^, v” soft keys.
2. Press the “Edit” soft key. The Scanner channel edit screen will now be displayed.
3. Use the “< >” soft keys to select which scanner channel you want to edit then press the change key to select H, L, O. The three different selectable scanner states are L (scanner channel set to the return point), H (scanner set to the high voltage point or continuity output) and O (OFF). Once the channel is set, press ENTER to accept the new setting or EXIT to cancel.

**Reviewing the scanner settings**

From the Perform Tests screen, press the "Step" soft key. The soft keys will now change to Step -, Step +, and Edit. The display will appear as follows:

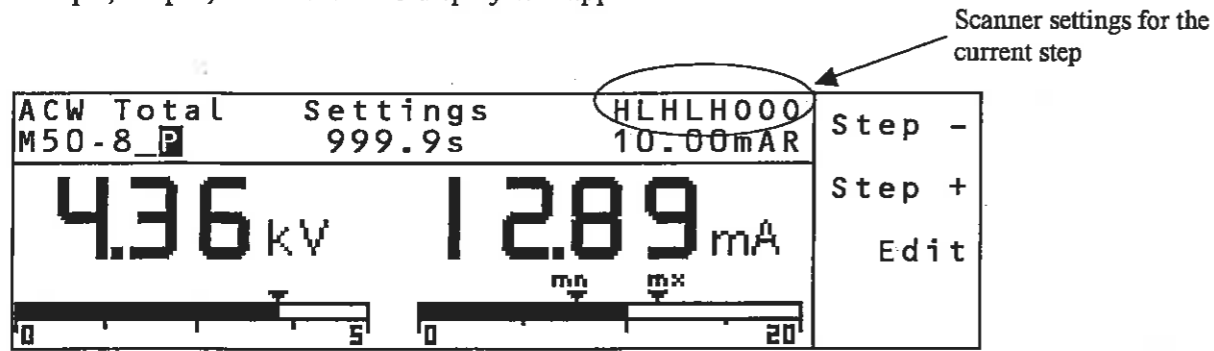

When the scanner is installed, a scanner status display will replace the memory name. This feature allows you to quickly review the scanner settings of the individual steps by pressing the "Step + and Step-" soft keys.

**Running Scanner Status**

When the scanner is installed, a live scanner status will appear in the upper right corner of the display while a test is being performed.

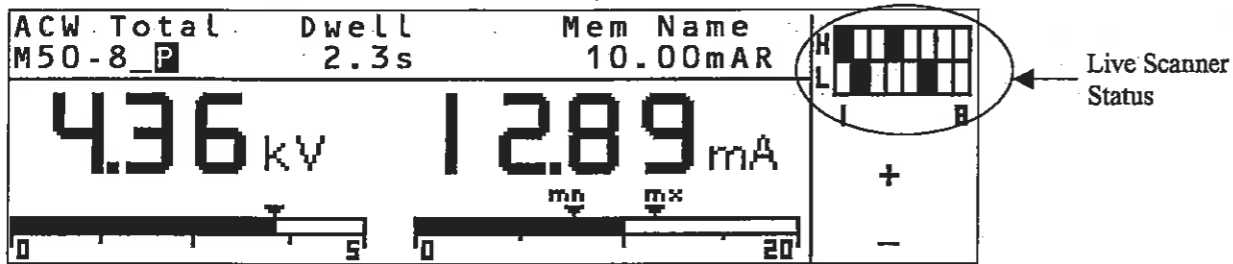

The Live Scanner Status gives direct visual feedback of the state of all eight of the scanner channels. The numbers indicate the channel numbers from left to right and the blocks represent channels 1-8. A darkened "H" block indicates that channel is set to be a High Voltage/Continuity output. A darkened "L" block indicates the channel is set to be a return connection. An open block indicates that the scanner channel is set to OFF. For the example illustrated below the channels are set as follows: Channel 1= High Voltage, Channel 2= Return, Channel 3= OFF, Channel 4 =High Voltage, Channel 5=OFF, Channel 6= Return, Channel 7 = OFF, Channel 8= OFF.

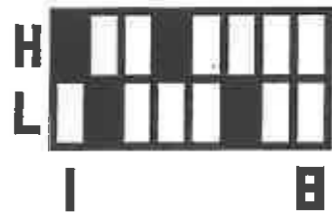

#### 02 4 Channel Scanner with Continuity

This option is the same as Option 01, 8 Channel Scanner with Continuity, with the exception that the numbers of channels are limited to 4. The scanner functions the same as the 8-channel option but the scanner status display will only indicate the status of channels 1-4, even though all 8 channel indicators are displayed.

#### 06 Dual Remote Test Switches

The Dual Remote Test Switch option allows the user to configure dual palm switches for safe production line operation.

To activate the option, press the System key to open the System menu. The System screen will appear as follows:

PLC Remote	OFF	Results	LAST	^
Single Step	OFF	Cal Alert	ON	
Fail Stop	ON	Cal Date	XX/XX/XX	v
Alarm	5	Cal Due	XX/XX/XX	
Contrast	5	Alert	XX/XX/XX	< >
Lock	OFF	Date mdy	XX/XX/XX	
Mem Lock	ON	Time	XX:XX AM	
Smart GFI	ON	Dual Test	OFF	Edit

**NOTE:** If the GPIB or Printer Options are installed, the System menu will look differently, and will consist of two pages with the Dual Test parameter appearing on the second page.

Scroll through the System Menu using the ^ (up)/v (down) keys and change PLC Remote to ON and Dual Test to ON.

The rear panel remote interface is reconfigured to allow two test switches instead of the standard reset and test inputs. The two test switches have to be pressed within 0.5 seconds to activate the test process. The two test switches must remain closed to continue the test. If either of the test switches is released, the process will be shut down immediately. The functions of the Test and Reset switches on the front panel will be disabled if the dual test switches are enabled. When the Dual Test parameter is turned OFF, the Test and Reset switches on the front and rear panel behave the same as the standard instrument, and are controlled by the PLC Remote On/Off selection.

#### 08 Printer Port Option

This option allows the instrument to generate a hardcopy printout of the test results. The printout can be configured to print automatically with each test or manually by pressing a front panel key. There is also capability to enter a device ID number to each test that increments automatically after each test is performed. The test can be further configured to print only results from tests that have failed or to print all test results from every test performed.

The Printer Port is a parallel interface and should be compatible with most parallel printers. The printer port output uses simple ASCII characters and control codes. Simply connect the printer



to the HypotULTRA III and configure the printer output using the Setup Systems menu. At the System Setup screen, scroll the highlighted area to <more>. The Print Format setting screen will now be displayed. From the Print Format setting screen, six different parameters may be accessed; Device ID number, Mode, Test Result, Test Setting, Device ID, and Form Feed. The Print Format setting screen will appear as follows:

PLC Remote	ON	Results	LAST	^
Single Step	ON	Cal Alert	ON	
Fail Stop	ON	Cal Date	XX/XX/XX	v
Alarm	5	Cal Due	XX/XX/XX	
Contrast	5	Alert	XX/XX/XX	< >
Lock	ON	Date mdy	XX/XX/XX	
Mem Lock	ON	Time	XX:XX AM	Edit
Smart GFI	ON		<more>	



Device ID	XXXXXXX			^
Device ID	ON			
Prn Mode	UTO			v
Prn Result	ALL			
Prn Setting	ON			< >
Form Feed	ON			Edit

**Mode**

From the Print Format setting screen, press the “Mode” soft key. As the soft key is pressed, the mode will change between three available print modes Auto, Manual and OFF.

In the Auto mode, the HypotULTRA III will automatically send the test results to the printer at the end of every complete test. The ENTER key may also be used from the end of test summary screen or the results screen to create additional printouts as needed.

In the manual mode, there are three different ways to create a printout. The first method is to press the ENTER key at the end of a test. The second method is to press the ENTER key from the Results screen. The third way is to press the Print Results softkey from the Perform test screen.

In the OFF mode, the printer card and printer menuing are disabled.

**Test Result**

From the Print Format setting screen, press the “Test Result” soft key. As the soft key is pressed, the display will toggle between the words “All” and “Fail only”. This command selects which test results will be printed, “All”, selects printing all test results and “Fail only”, selects printing only failed test results.

### Test Setting

From the Print Format setting screen, you may turn the Test Setting print enable ON and OFF by pressing the "Test Setting" soft key. This command selects printing the test parameters as well as the test results.

### Device ID

The Device ID number is a counter that increments once every time a test is performed. The number can be set to match the exact serial number or some portion of actual serial number of the item under test or just used as an identifier or tracking number. From the Print Format setting screen, use the numeric keypad to select the initial Device ID. Finish by pressing the ENTER key. This number is not saved as part of the non-volatile system parameters; therefore, each time the power to the instrument is turned off the number will be reset to 1.

### Form Feed

From the Print Format setting screen, you may turn the Form Feed ON and OFF by pressing the "Form Feed" soft key. This command forces a form feed after each complete test sequence. When the form feed is turned off, the signature line will not appear. When the form feed is turned off the pages will break whenever the page is determined to be full by the printer.

**Sample Printer Outputs**

The following is a sample print of a two-step test with the Print Format settings as follows:

Test Results: All, Test Setting: ON, Device ID: ON, Form Feed: ON

```
=====
Model: 7650                      Time: 14:23:18  Date: 03/30/01
Device ID: 0123456789           Test Memory: 02  Name: ARTEST1
=====
```

TEST 01 Setting: ACW

```
Voltage  xxxxV                Max-Lmt T  xx.xxmA                Min-Lmt T
xx.xxmA

Ramp UP   xxx.xs                Dwell Time xxx.xs                Ramp Down
xxx.xs

Arc Sense  xx                  Max-Lmt R  xx.xxmA                Min-Lmt R
xx.xxmA

Frequency 60Hz                Arc Detect  ON  Continuity ON

Scanner  HHHLLLHLHL
```

TEST 01 Result: Pass

```
Voltage  xxxxV                Current T   xx.xxmA                Current R
xx.xxmA

Time      1.0s
```

-----

TEST 02 Setting: IR

```
Voltage  xxxxV                Max-Lmt    x.xx Mohms                Min-Lmt
x.xxMohms

Ramp Up  xxx.xs                Delay xxx.xs                Ramp DN xxx.xs

Charge LO 0.000uA

Connect  ON                    Scanner 00000000
```

TEST 02 Result: Fail

Fail Type: Max-Lmt

```
Voltage  xxxV                Resistance  xx.xGohms                Time
0.0s
```

-----

Tested By: \_\_\_\_\_

The following is a sample print of a two-step test with the Print Format settings as follows:

Test Results: Fail Only, Test Setting: OFF, Device ID: OFF, Form Feed: ON. The failure occurred in the second step only.

```
=====
Model: 7650                               Time: 14:23:18   Date: 03/30/01
Device ID: 0123456789                     Test Memory: 02   Name: ARTEST1
```

TEST 02 Setting: CONT

```
Max Lmt    xx.xxohms      Min Lmt    xohms      Dwell      1.0s
Offset     x.xxohms
Connect    OFF                 Scanner    00000000
```

Test02 Result: Fail      Fail Type: Max-Lmt

Tested By: \_\_\_\_\_

The following is a sample print of a single step test ( performed repeatedly) with the Print Format settings as follows:

Mode: Auto, Test Results: All, Test Setting: OFF, Device ID: ON, Form Feed: OFF

```
=====
Model: 7650                               Time: 14:23:18   Date: 03/30/01
Device ID: 01                             Test Memory: 02   Name: ARTEST1
```

TEST 01 Result: Pass

```
Voltage  xxxxV      Total I  xx.xxmA     Real I   xx.xxmA     Time x.xs
```

```
=====
Model: 7650                               Time: 14:23:18   Date: 03/30/01
Device ID: 02                             Test Memory: 02   Name: ARTEST1
```

TEST 01 Result: Pass

```
Voltage  xxxxV      Total I  xx.xxmA     Real I   xx.xxmA     Time x.xs
```

```

-----
=====
Model: 7650                Time: 14:23:18   Date: 03/30/01
Device ID: 03             Test Memory: 02   Name: ARTEST1
=====

```

TEST 01 Result: Pass

```

Voltage  xxxxV      Total I  xx.xxmA      Real I  xx.xxmA      Time x.xs
-----

```

The page will break whenever the printer determines the page is full and will not display a signature line. The device ID will continue to increment every time the test is performed until the instrument is powered down.

#### 10 GPIB Interface

This option may be substituted for the RS232 interface. This option provides all of the function control of the RS232 interface with the addition of SRQ functions. All commands can be found in section 7. **Bus Remote Interface GPIB/RS-232** of this manual.

#### 14 3 mA AC Output

The 3 mA AC Output option limits the AC Dielectric Withstand Mode output current with software control. The trip points are adjusted to a maximum of 3 mA and the software has been modified so the high-speed maximum current shutdown is fixed at 3 mA.

The revised Dielectric Withstand Test Mode specifications are as follows.

DIELECTRIC WITHSTAND TEST MODE	
Output Rating	5 KV @ 3 mA AC 5 KV @ 10 mA DC for 7650 only
Max and Min-Limit	
AC Total	Range 1: 0.000 – 3.000 mA Resolution: 0.001mA Accuracy: ± (2% of setting + 2 counts)
AC Real	Range 1: 0.000 – 3.000mA Resolution: 0.001mA Accuracy: ± (3% of reading + 0.05mA) PF > 0.1 V > 250VAC

DIELECTRIC WITHSTAND TEST MODE	
DC	Range 1: 0.0 – 999.9 $\mu$ A for 7650 only Resolution: 0.1 $\mu$ A Range 2: 1000 – 10000 $\mu$ A for 7650 only Resolution: 1 $\mu$ A Accuracy: $\pm$ (2% of setting + 2 counts)
Current Display	Auto Range
AC Total	Range 1: 0.000mA – 3.000mA Resolution: 0.001mA Accuracy: $\pm$ (2% of setting + 2 counts)
AC Real	Range : 0.000mA – 3.000mA Resolution: 0.001mA Accuracy: $\pm$ (3% of reading + 0.05mA) PF > 0.1 V > 250VAC
DC	Range 1: 0.0 $\mu$ A – 350.0 $\mu$ A for 7650 only Resolution: 0.1 $\mu$ A Range 2: 0.300 mA – 3.500 mA for 7650 only Resolution: 0.001mA Range 3: 3.00 mA – 9.99 mA for 7650 only Resolution: 0.01mA Accuracy: $\pm$ (2% of reading + 2 counts)

## 10. Calibration Procedure

This instrument has been fully calibrated at the factory in accordance to our published specifications. It has been calibrated with standards traceable to the National Institute Standards & Technology (NIST). You will find in this manual a copy of the "Certificate of Calibration". It is recommended that you have this instrument re-calibrated and a safety check done at least once per year. AR recommends you use "Calibration Standards" that are NIST traceable, or traceable to agencies recognized by NIST to keep this instrument within published specifications.

End user metrology standards or practices may vary. These metrology standards determine the measurement uncertainty ratio of the calibration standards being used. Calibration adjustments can only be made in the Calibration mode and calibration checks or verifications can only be made while operating in Test mode.

### 10.1. Warranty Requirements

AR offers a standard one-year manufacture's warranty. Customers are only required to go through the owner registration procedures to be eligible. This warranty can be extended an additional four years provided that the instrument is returned each year to Associated Research, Inc. for its annual calibration. In order to be eligible for the extended warranty instruments must be purchased and used in North America and returned to Associated Research, Inc. for calibration service at least once every twelve months. A 3-Year warranty is also available for instruments purchased and used in North America. All costs for this warranty are paid with the initial purchase and include warranty coverage, annual calibration and standard ground return freight for three years. However, unlike our 5-year program annual calibration and inspection by Associated Research is not required.

A return material authorization number (RMA) must be obtained from AR before returning this instrument for calibration. To obtain an RMA number or for information regarding our warranty please contact our Customer Support Representatives at 800-858-TEST.

#### Required Calibration Equipment

- 0 - 5 KV AC/DC Metered Voltage Divider.
- 30 mA AC, 10 mA DC Ammeter.
- 20 $\Omega$ , 0.25 watt resistor, 250 volt.
- 200 $\Omega$ , 0.25 watt resistor, 250 volt.
- 2000 $\Omega$ , 0.25 watt resistor, 250 volt.
- 50M $\Omega$ , 0.25 watt resistor, 1000 volt.
- 500M $\Omega$ , 0.25 watt resistor, 1000 volt.
- 100K $\Omega$ , 250 watt resistor, 5000 volt.
- 1M $\Omega$ , 20 watt resistor, 5000 volt.

## 10.2. Calibration Initialization

Press and hold the calibration key on the rear panel with a pen, pencil, or small screwdriver while powering ON the HypotULTRA III. The HypotULTRA III enters calibration mode after the power on sequence is complete. The Initial Calibration screens will appear as follows:

CALIBRATION		^
AC 5000V	ACR 20W/30mA	v
DC 5000V	ACR 20W/3.5mA	< >
IR 1000V	ACR 2W/3.5mA	
ACT 30.00mA	DC 9.99mA	Select
ACT 3.500mA	DC 3.500mA	
ACR 200W/30mA	<More>	

↓

CALIBRATION		^
DC 350.0uA	CONT 2000Ω	v
IR 999.99MΩ		< >
IR 9999.9MΩ		
IR 50000MΩ		Select
CONT 20.00Ω		
CONT 200.0Ω		

## 10.3. Selecting Specific Calibration points

When the calibration is initialized, the first calibration point is automatically selected. The calibration is set up so that as each calibration point is completed the highlighted area will automatically scroll to the next calibration point.

To manually select calibration points, use the up and down arrows to scroll the highlighted area to the desired calibration point.

## 10.4. Calibration of Parameters

From the Calibration screens, use the arrow keys to scroll the Cursor to the parameter you wish to calibrate. Once the cursor is pointing to the parameter you wish to calibrate, press the "Select" soft key. A calibration prompt screen will now appear that describes the necessary load and connection information for the parameter being calibrated.

The following is a list of the calibration parameters and an example of the prompt screen with the details that will be displayed for each parameter (screen shown at top). Once you press TEST, the Calibration data entry screen will appear for the selected parameter (screen shown at bottom). Read the measurement from your standard and enter it using the numeric keypad. You may now store the new calibration number by pressing the ENTER key or escape by pressing the EXIT key or the RESET button.



#### 10.4.1. Calibration of AC Hipot Voltage

CALIBRATION

Connect the standard 5kVAC kilovolt meter from H.V to Return.

When the voltmeter is connected, press TEST to start the calibration process. Press EXIT or RESET to cancel.

CALIBRATION

Enter the standard voltage reading.

Voltage=

Press RESET to cancel.

#### 10.4.2. Calibration of DC Hipot Voltage

CALIBRATION

Connect the standard 5kVDC kilovolt meter from H.V to Return.

When the voltmeter is connected, press TEST to start the calibration process. Press EXIT or RESET to cancel.

CALIBRATION

Enter the standard voltage reading.

Voltage=

Press RESET to cancel.

10.4.11. Calibration of 3.500mA DC Current Range

CALIBRATION

Connect the 100k $\Omega$  load in series with  
3.5mADC current meter.

When the load and meter are connected,  
press TEST to start the calibration  
process. Press EXIT or RESET to cancel.

CALIBRATION

Enter the standard current reading.

Current=

Press RESET to cancel.

10.4.12. Calibration of 350uA DC Current Range

CALIBRATION

Connect the 1Meg $\Omega$  load in series with  
350uADC current meter.

When the load and meter are connected,  
press TEST to start the calibration  
process. Press EXIT or RESET to cancel.

CALIBRATION

Enter the standard current reading.

Current=

Press RESET to cancel.

#### 10.4.13. Calibration of 999.99MΩ IR Range

CALIBRATION
Connect the standard 50MegΩ load from HV to Return.  When the standard load is connected, press TEST to start the calibration process. Press EXIT or RESET to cancel.

CALIBRATION
Automatic calibration process.

#### 10.4.14. Calibration of 9999.9MΩ IR Range

CALIBRATION
Connect the standard 50MegΩ load from HV to Return.  When the standard load is connected, press TEST to start the calibration process. Press EXIT or RESET to cancel.

CALIBRATION
Automatic calibration process.

10.4.15. Calibration of 50000M $\Omega$  IR Range

CALIBRATION
Connect the standard 500Meg $\Omega$ load from HV to Return.  When the standard load is connected, press TEST to start the calibration process. Press EXIT or RESET to cancel.

CALIBRATION
Automatic calibration process.

10.4.16. Calibration of DC Continuity 20 $\Omega$

CALIBRATION
Step 1: Short the Cont. Check and Return leads together.  When the leads are shorted, press TEST to start the calibration process. Press EXIT or RESET to cancel.

CALIBRATION
Step 2: Connect the standard 20 $\Omega$ from Cont. Check to Return.  When the load is connected, press TEST to start the calibration process. Press EXIT or RESET to cancel.

This screen will appear after both steps 1 and 2.

CALIBRATION
Automatic calibration process.

10.4.17. Calibration of DC Continuity 200Ω

CALIBRATION
Step 1: Short the Cont. Check and Return leads together.
When the leads are shorted, press TEST to start the calibration process. Press EXIT or RESET to cancel.

CALIBRATION
Step 2: Connect the standard 200Ω from Cont. Check to Return.
When the load is connected, press TEST to start the calibration process. Press EXIT or RESET to cancel.

This screen will appear after both steps 1 and 2.

CALIBRATION
Automatic calibration process.

10.4.18. Calibration of DC Continuity 2000Ω

CALIBRATION
Step 1: Short the Cont. Check and Return leads together.
When the leads are shorted, press TEST to start the calibration process. Press EXIT or RESET to cancel.

CALIBRATION
Step 2: Connect the standard 2000Ω from Cont. Check to Return.
When the load is connected, press TEST to start the calibration process. Press EXIT or RESET to cancel.

This screen will appear after both steps 1 and 2.

CALIBRATION
Automatic calibration process.

## 11. Replacement Parts List

Rev: E 4-14-2005 ECO 5110

Part Number	Qty.	Ref. Designator	Description
<b>Supplied Accessories</b>			
37563	2	-	2U Rack Mount Handle
37564	2	-	2U Rack Mount Bracket
38549	4	-	Screw for Rack Mount Handle/Bracket
38388	1	-	Fuse 4A 250V Slow Blow 20mm
04040A-08	1	-	High Voltage Cable
02100A-13	2	-	Cable Assembly Return
37863	1	-	RS232 Cable
33189	1	-	Cable Input Cordset USA
38075	1	-	Interlock Connector
36544	1	-	Adapter Box
<b>Panel Components</b>			
35999	1	-	Black Banana Jack
37478	2	-	High Voltage Connector
38069	1	-	Power Switch 2P 15A
37571	1	-	Earth Connector
37806	1	TEST	Test Switch Green Lighted
37807	1	RESET	Reset Switch Red Lighted
37854	1	Test/Pass	Replacement Bulb 28V
37605	1	Reset/Fail	Replacement Bulb 33V
38364	1	-	Fuse Holder 5 x 20 PCB Mount
38101	1	-	Feet Kit w/o Rubber Inserts
38102	4	-	Rubber Insert for Feet
38407	1	-	Graphic LCD Display
<b>PCB Assemblies</b>			
38394	1	CON7650	Main Control Board
38194	1	REA7500	Real Current Board
38478	1	HV7650 (7650 only)	High Voltage Control Board
38479	1	HV7650 (7620 only)	High Voltage Control Board
38390	1	AMP7650	Amplifier Board
38396	1	KEYU3	Key Board
38401	1	CSU7650	8 Channel Scanner Board
38402	1	CSU7650	4 Channel Scanner Board
37814	1	RS232	RS232 Interface Board
38305	1	CGP-03	GPIB Interface Board
38311	1	CPR-01	Printer Card

Part Number	Qty.	Ref. Designator	Description
<b>Internal Components</b>			
38235	1	IC 27	IC 29C020 EEPROM DIP
38424	1	IC 31	IC BQ3287 Real-Time Clock
38298	1	IC 40	IC ATF16V8B 20pin PLCC
38427	1	IC 41	IC 29C020 EEPROM PLCC
38428	1	IC 51	IC XA-G30 Microcontroller
38391	1	T1	Input Transformer
38393	1	T2	High Voltage Output Transformer

- For safety tester interconnect cables, refer to INSTRUMENT CONNECTIONS; section 1.3 Specific Integrated System Connections



## 12. Schematic Index

Drawing Number	Description	Reference Designator	Pages
S07650	Wiring Diagram	-	1
S38394	Main Control Board	CON7650	7
S38194	Real Current Board	REA7500	1
S38478	HV Control Board	HV7650	2
S38390	Amplifier Board	AMP7650	2
S38392	Connector Transfer Board	CNR7650	1
S38396	Keypad Board	KEYU3	1
S38401	Scanner Control Board	CSU7650	1
S37745	GPIB Interface Board	CGP-03	1
S37814	RS-232 Interface Board	RS232	1
S38311	Printer Card	CPR-01	1

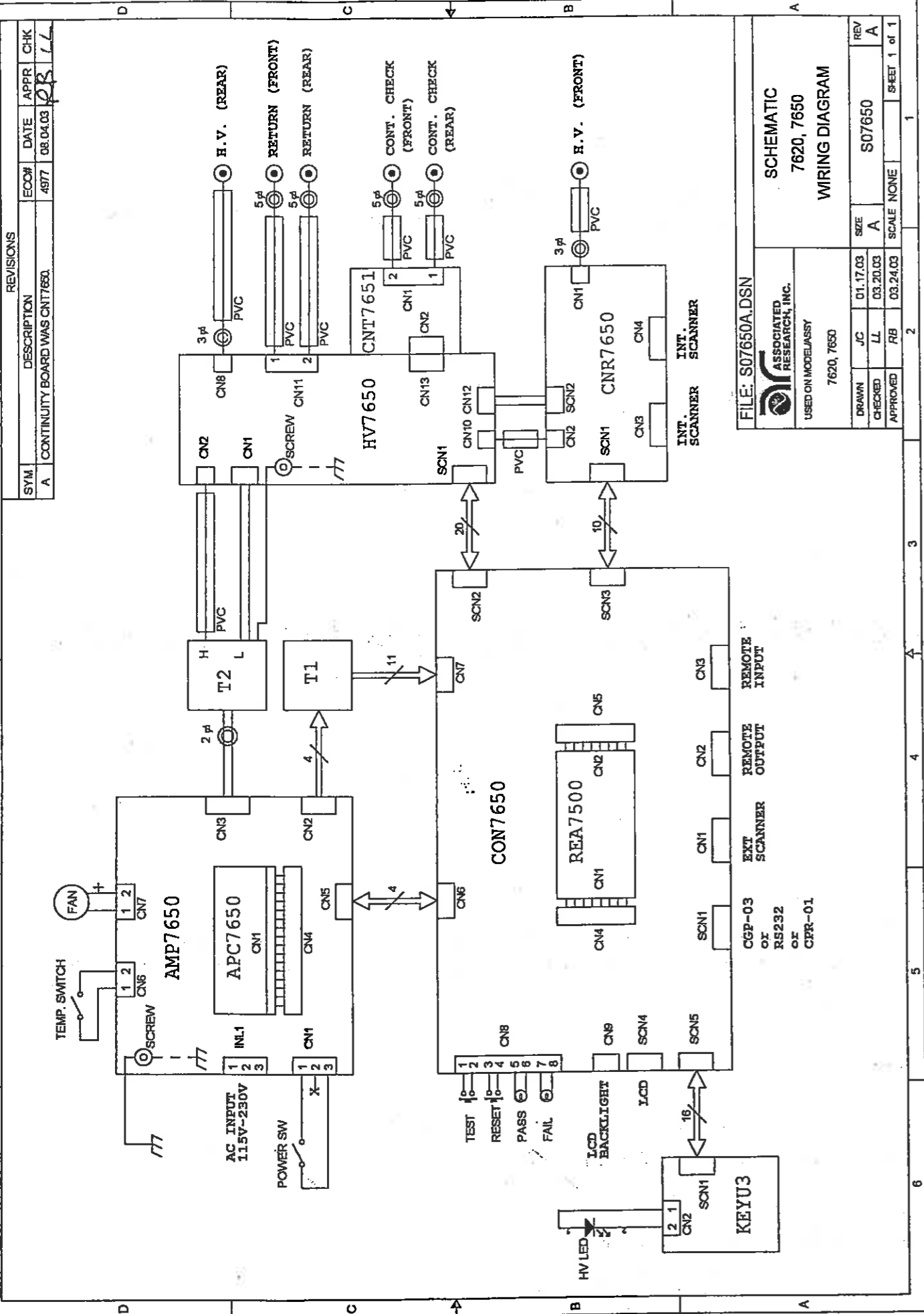

SYM	DESCRIPTION	ECC#	DATE	APPR	CHK
A	CONTINUITY BOARD WAS CNT7650	4977	08.04.03	BB	LL

REVISIONS					
SYM	DESCRIPTION	ECC#	DATE	APPR	CHK
A	CONTINUITY BOARD WAS CNT7650	4977	08.04.03	BB	LL

FILE: S07650A.DSN  
 ASSOCIATED RESEARCH, INC.  
 USED ON MODEL/ASSY  
 7620, 7650

DRAWN	JC	SIZE	REV
CHECKED	LL	A	A
APPROVED	RB	SCALE NONE	SHEET 1 of 1

SCHEMATIC  
 7620, 7650  
 WIRING DIAGRAM

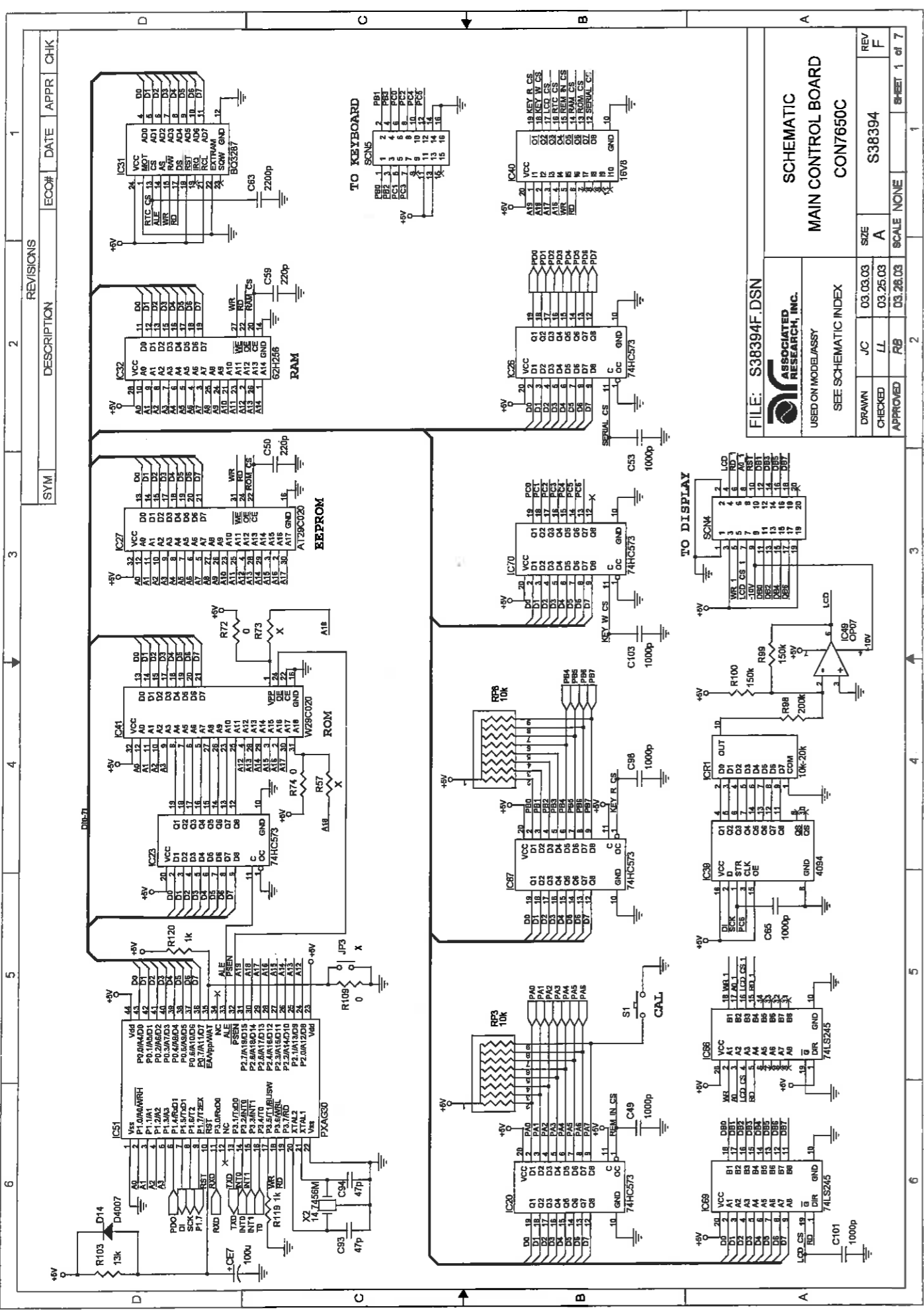

FILE: S38394F.DSN  
 ASSOCIATED RESEARCH, INC.  
 USED ON MODEL/ASSY:  
 SEE SCHEMATIC INDEX

SCHEMATIC INDEX  
 MAIN CONTROL BOARD  
 CON7650C

DRWN	JC	03.03.03	SIZE	A	REV	F
CHECKED	LL	03.25.03	SCALE	NONE		
APPROVED	RB	03.26.03				SHEET 1 of 7

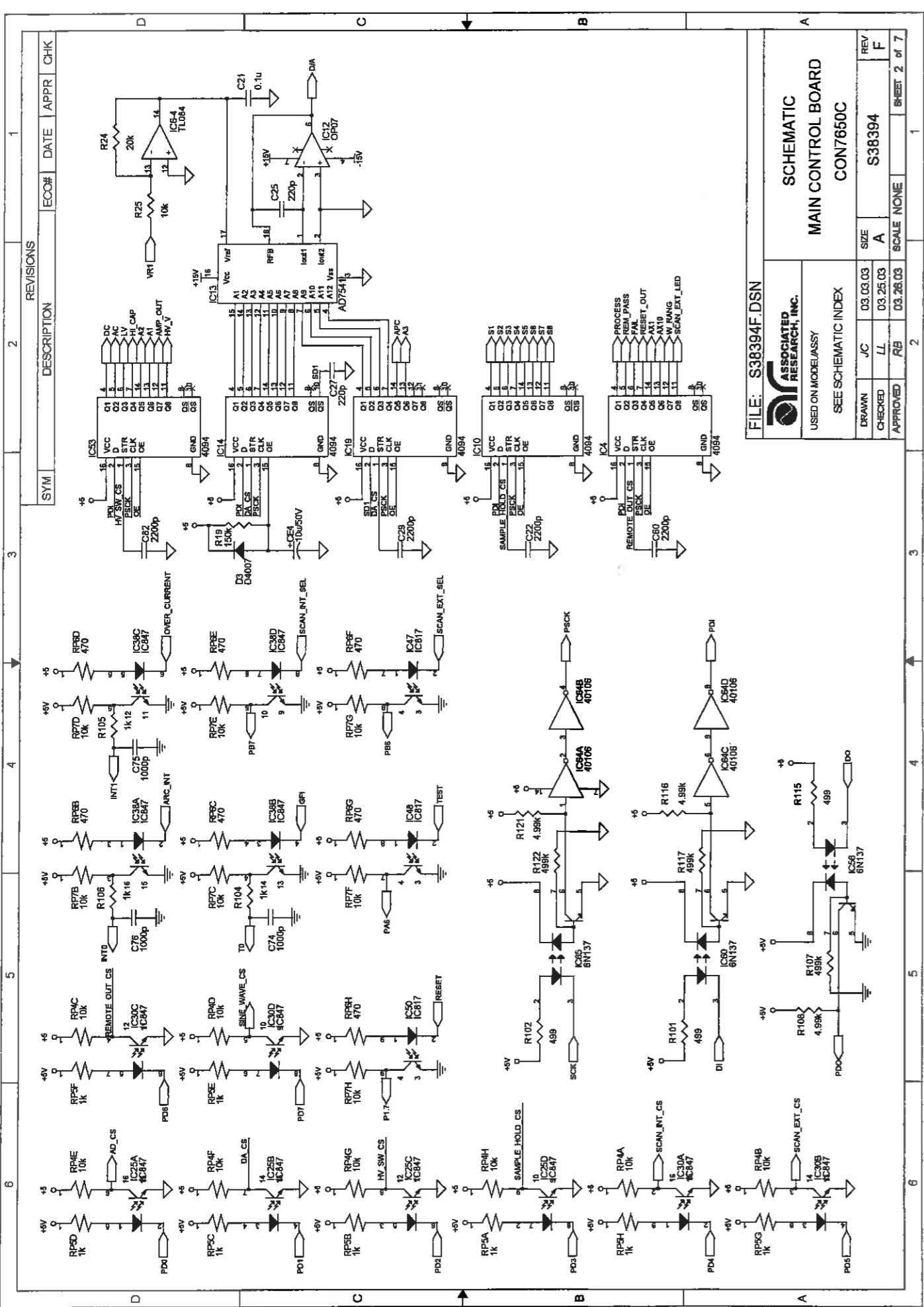

FILE: S38394F.DSN



USED ON MODEL/ASSY

SEE SCHEMATIC INDEX

SCHEMATIC  
MAIN CONTROL BOARD  
CON7650C

REV	DATE	BY	CHK
F	03.03.03	A	F
E	03.03.03	A	F
D	03.03.03	A	F
C	03.03.03	A	F
B	03.03.03	A	F
A	03.03.03	A	F

SYMBOL	DESCRIPTION	ECO#	DATE	APPROVED	CHK
DC	DC				
AC	AC				
LV	LV				
HI CAP	HI CAP				
AT	AT				
AMP OUT	AMP OUT				
AMP HV_V	AMP HV_V				
CS3	CS3				
VCC	VCC				
D	D				
STR	STR				
CLK	CLK				
OE	OE				
GND	GND				
4094	4094				
IC14	IC14				
VCC	VCC				
D	D				
STR	STR				
CLK	CLK				
OE	OE				
GND	GND				
4094	4094				
IC19	IC19				
VCC	VCC				
D	D				
STR	STR				
CLK	CLK				
OE	OE				
GND	GND				
4094	4094				
IC20	IC20				
VCC	VCC				
D	D				
STR	STR				
CLK	CLK				
OE	OE				
GND	GND				
4094	4094				
IC4	IC4				
VCC	VCC				
D	D				
STR	STR				
CLK	CLK				
OE	OE				
GND	GND				
4094	4094				

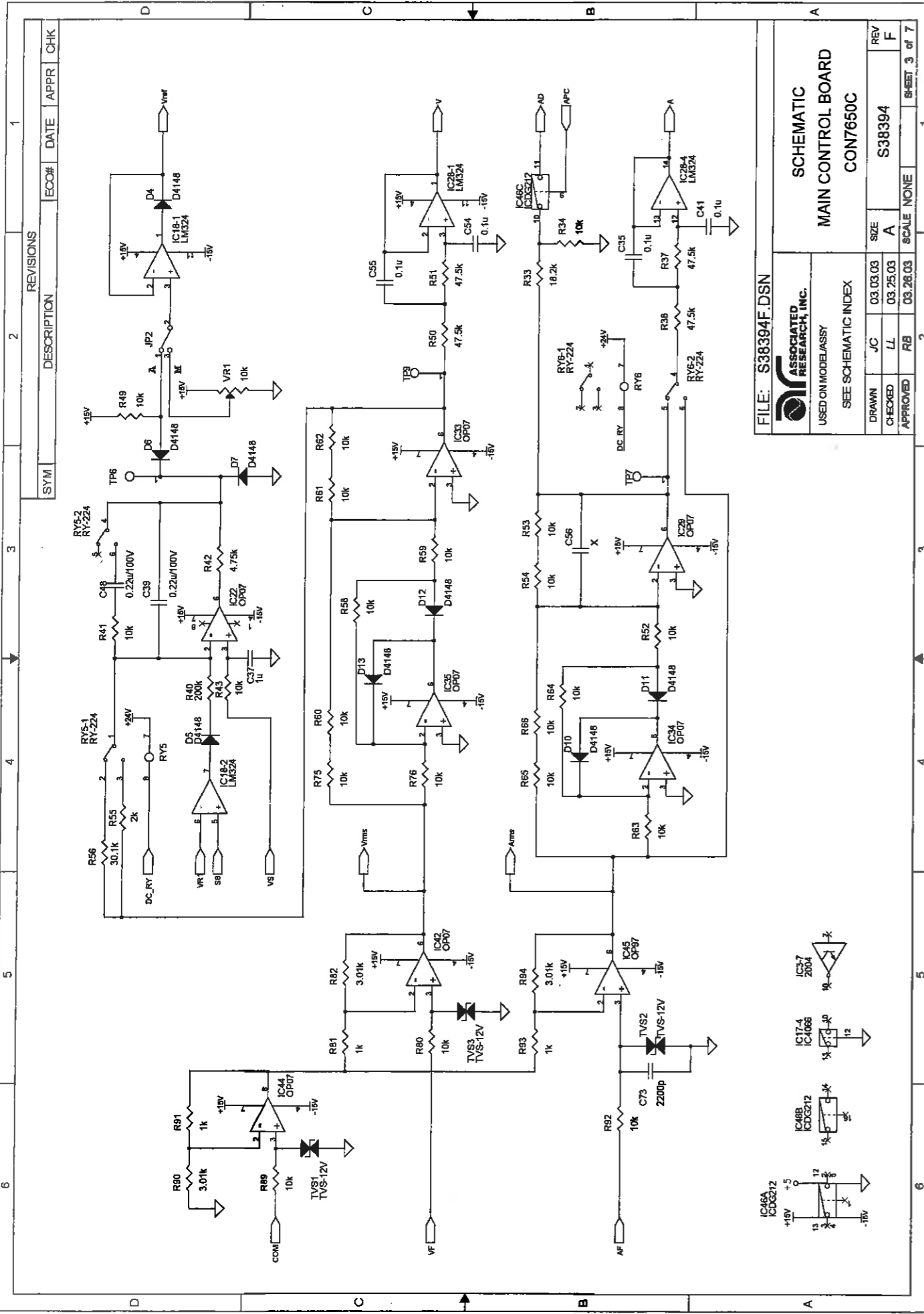

FILE: S38394F.DSN  
**ASSOCIATED RESEARCH, INC.**  
 USED ON MODEL/ASSY  
 SEE SCHEMATIC INDEX

**SCHEMATIC  
 MAIN CONTROL BOARD  
 CON7650C**

DRWN	JC	SIZE	REV
CHECKED	LL	03.25.03	A
APPROVED	RB	03.26.03	F

SCALE: NONE  
 SHEET 3 of 7

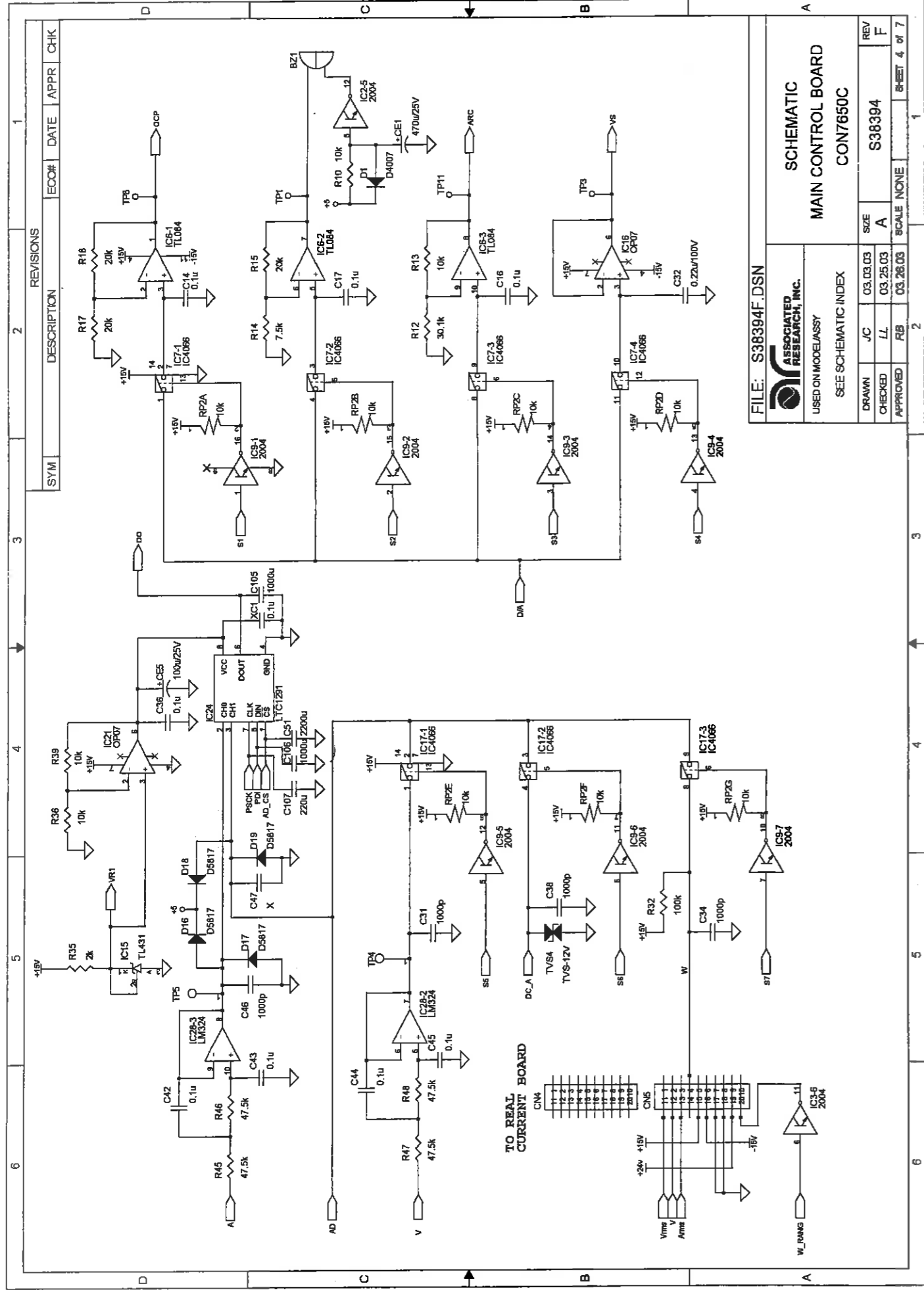

FILE: S38394F.DSN

ASSOCIATED RESEARCH, INC.

USED ON MODEL/ASSY

SEE SCHEMATIC INDEX

SCHEMATIC  
MAIN CONTROL BOARD  
CON7650C

REV	REV	SCALE	SCALE	SCALE	SCALE
JC	03.03.03	A	A	A	A
LL	03.25.03	A	A	A	A
FB	03.26.03	A	A	A	A
REV	S38394	SCALE	NONE	SCALE	NONE
REV	F	SCALE	NONE	SCALE	NONE
REV	F	SCALE	NONE	SCALE	NONE

SHEET 4 of 7

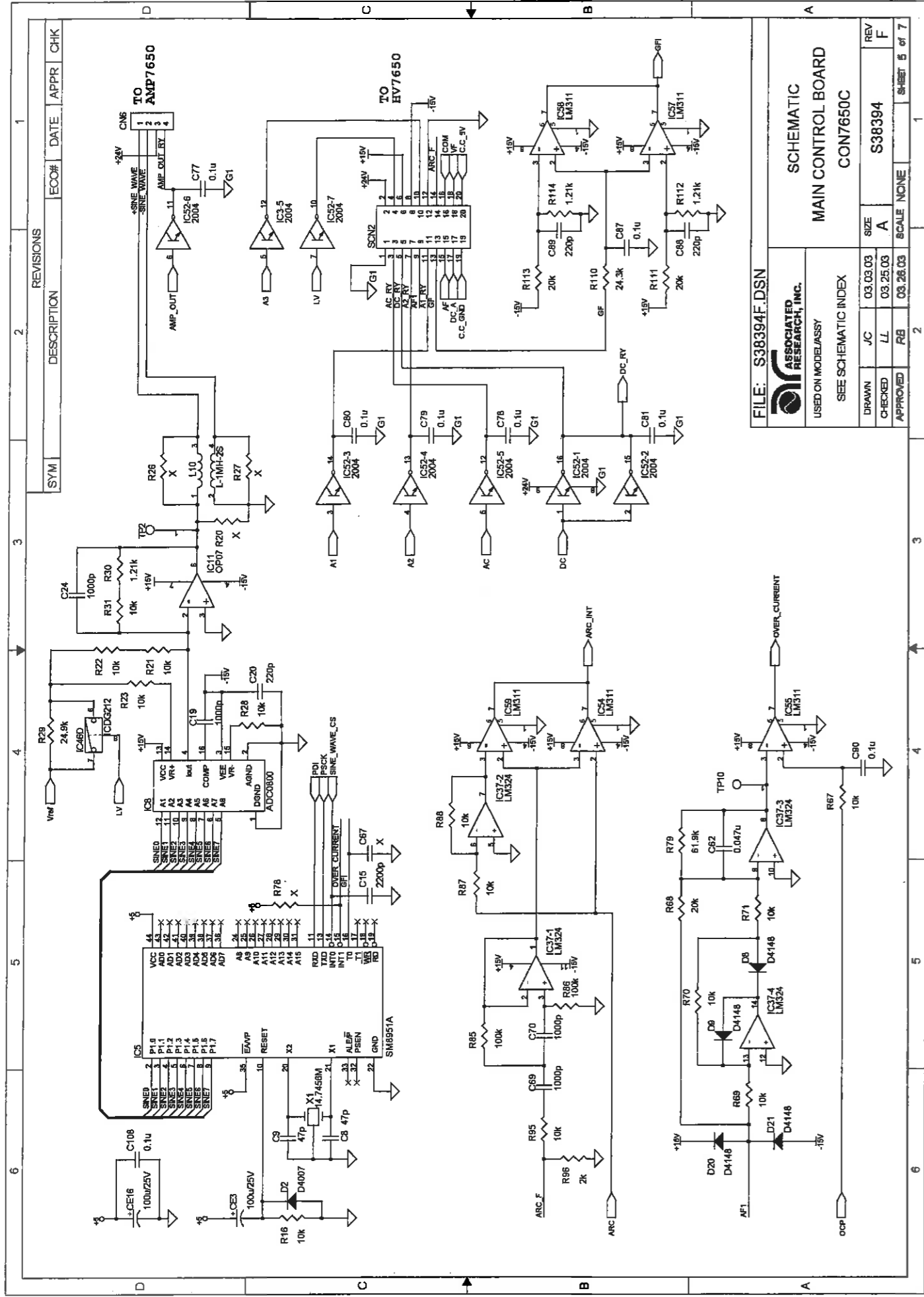

FILE: S38394F.DSN

ASSOCIATED RESEARCH, INC.

USED ON MODEL/ASSY

SEE SCHEMATIC INDEX

APPROVED	RB	03.26.03	SCALE	NONE
CHECKED	LL	03.25.03	SIZE	A
DRAWN	JC	03.03.03		

SCHEMATIC  
MAIN CONTROL BOARD  
CON7650C

REV	F
DATE	
APPR	
CHK	

SHEET 5 of 7

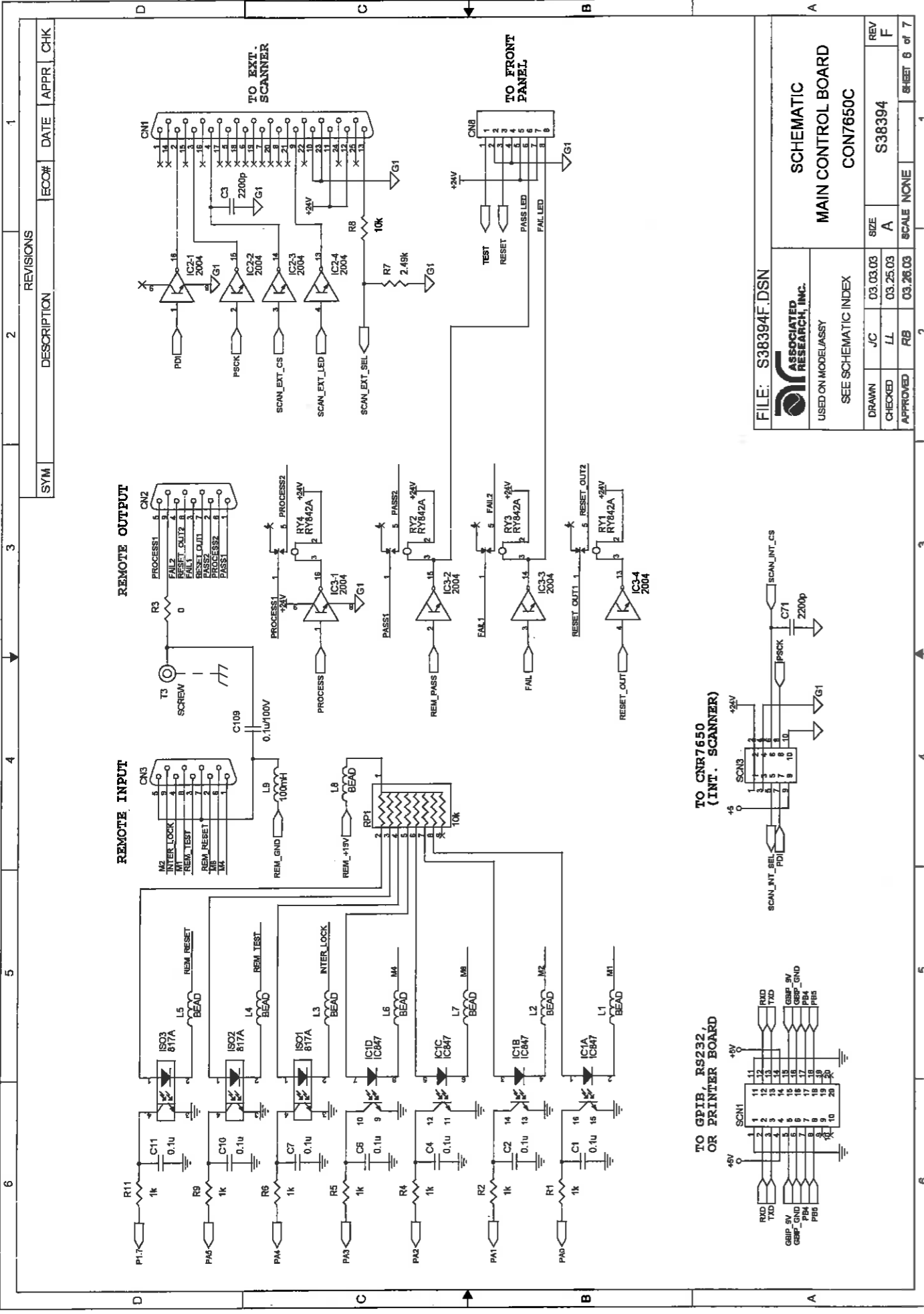

FILE: S38394F.DSN

**ASSOCIATED RESEARCH, INC.**  
USED ON MODEL/ASSY

SEE SCHEMATIC INDEX

DRAWN	JC	03.03.03	SIZE	A	REV	F
CHECKED	LL	03.25.03	SCALE	NC/NE	SHEET 6 of 7	
APPROVED	RB	03.26.03				

**SCHEMATIC MAIN CONTROL BOARD CON7650C**





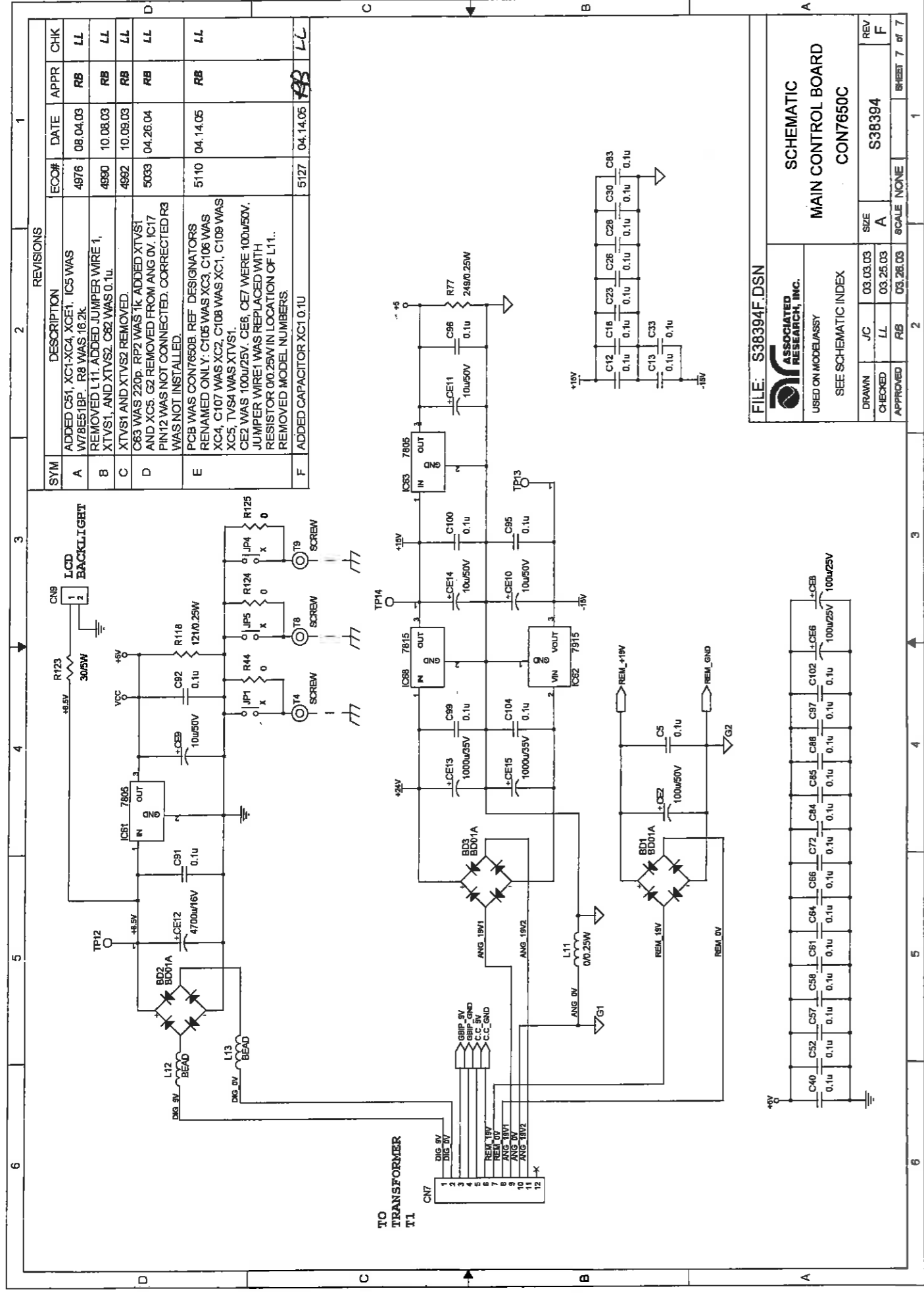

FILE: S38394F.DSN

ASSOCIATED RESEARCH, INC.

USED ON MODEL/ASSY

SEE SCHEMATIC INDEX

SCHEMATIC MAIN CONTROL BOARD CON7650C

DRAWN	JC	03.03.03	SIZE	A	S38394	REV
CHECKED	LL	03.25.03	SCALE	NONE		F
APPROVED	RB	03.26.03	SCALE	NONE		F

SHEET 7 of 7

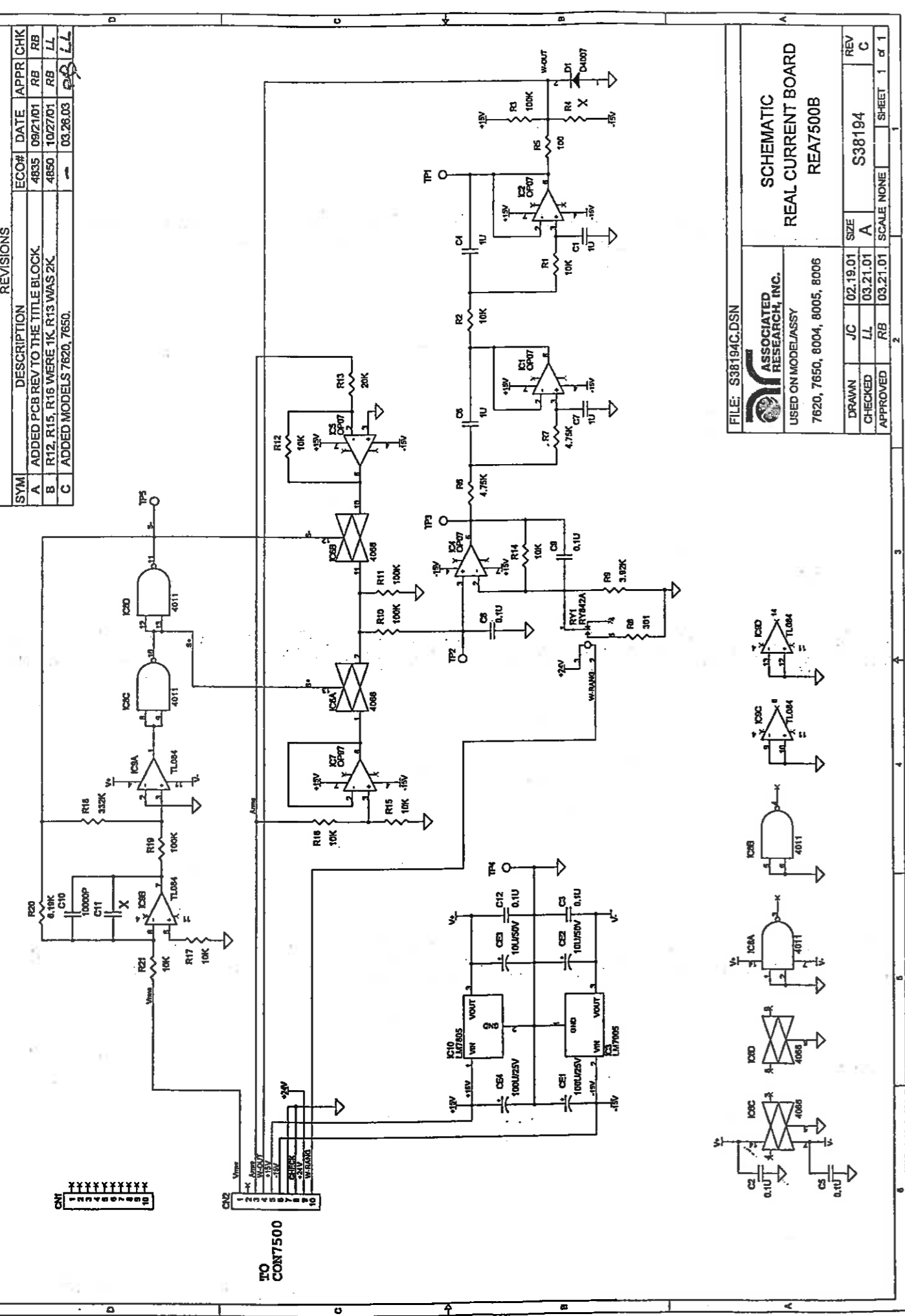

SYM	DESCRIPTION	ECO#	DATE	APPR	CHK
A	ADDED PCB REV TO THE TITLE BLOCK.	4835	09/21/01	RB	RB
B	R12, R15, R16 WERE TK, R13 WAS 2K.	4850	10/27/01	RB	LL
C	ADDED MODELS 7620, 7650.		03/26/03	RB	LL

REVISIONS

FILE: S38194C.DSN

**ASSOCIATED RESEARCH, INC.**  
USED ON MODEL/ASSY  
7620, 7650, 8004, 8005, 8006

**SCHEMATIC  
REAL CURRENT BOARD  
REA7500B**

DRAWN	JC	02.19.01	SIZE	A	REV	C
CHECKED	LL	03.21.01	SCALE	NONE	SHEET	1 of 1
APPROVED	RB	03.21.01				

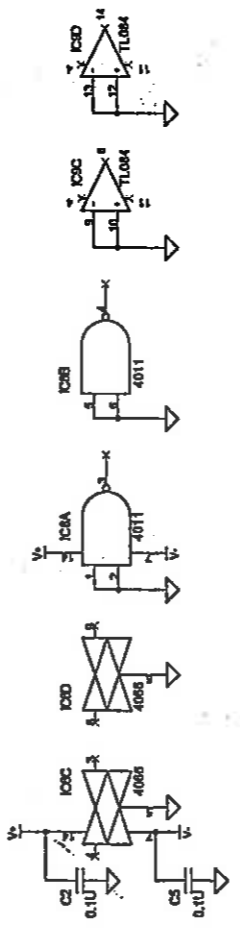

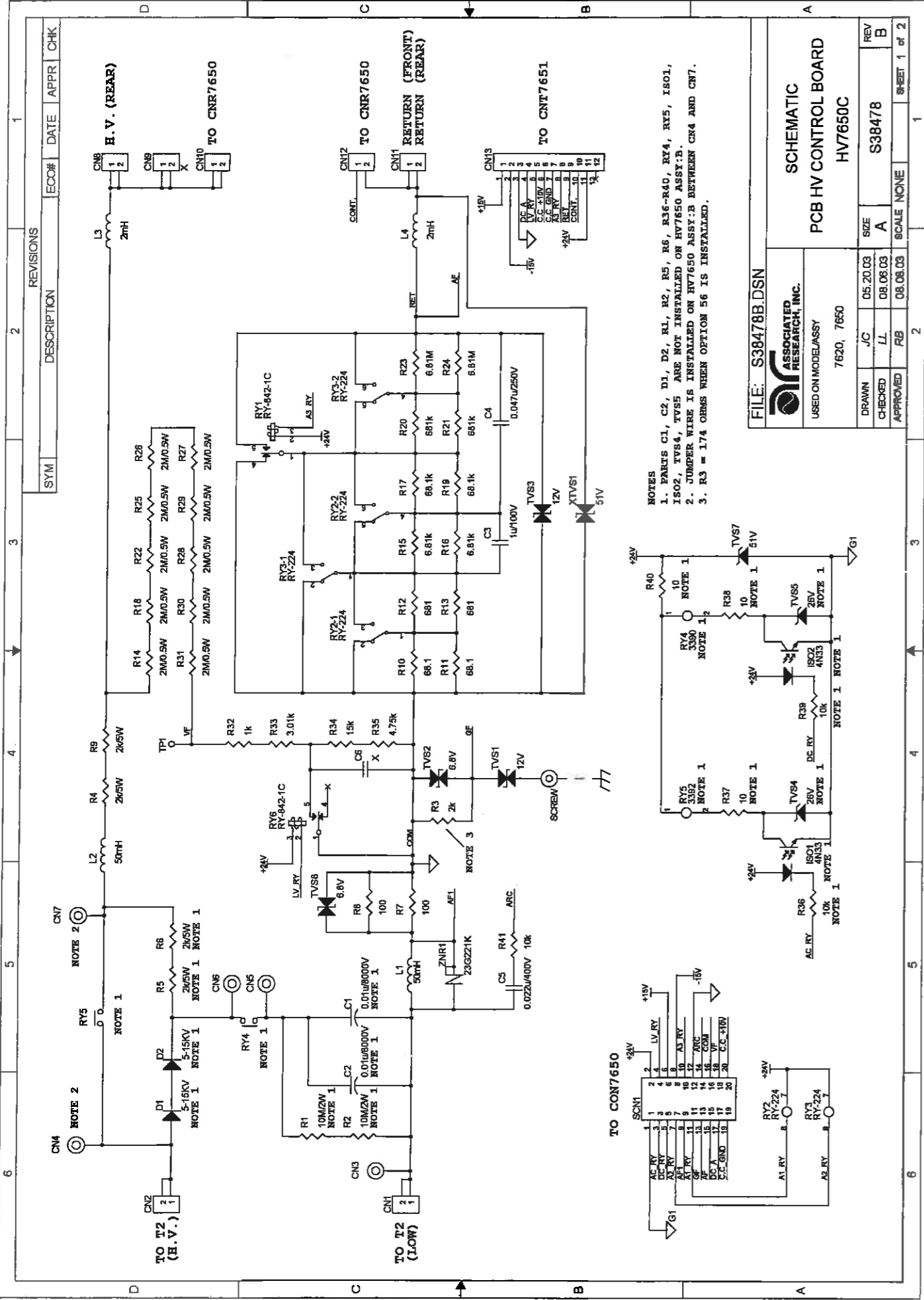

**NOTES**  
 1. PARTS C1, C2, D1, D2, R1, R2, R5, R6, R36-RA0, RY4, RY5, IS01, IS02, TVS4, TVS5 ARE NOT INSTALLED ON HV7650 ASSY:B.  
 2. JUMPER WIRE IS INSTALLED ON HV7650 ASSY:B BETWEEN CN4 AND CN7.  
 3. R3 = 17A OHMS WHEN OPTION 56 IS INSTALLED.

FILE: S38478B.DSN  
**ASSOCIATED RESEARCH, INC.**  
 USED ON MODEL/ASSY  
 7620, 7650

**SCHEMATIC**  
**PCB HV CONTROL BOARD**  
**HV7650C**

DRAWN	JC	DATE	05.20.03	SIZE	A	REV	B
CHECKED	LL	DATE	08.06.03	SCALE	NONE	SHEET	1 of 2
APPROVED	RB	DATE	08.08.03				

TO CN7650

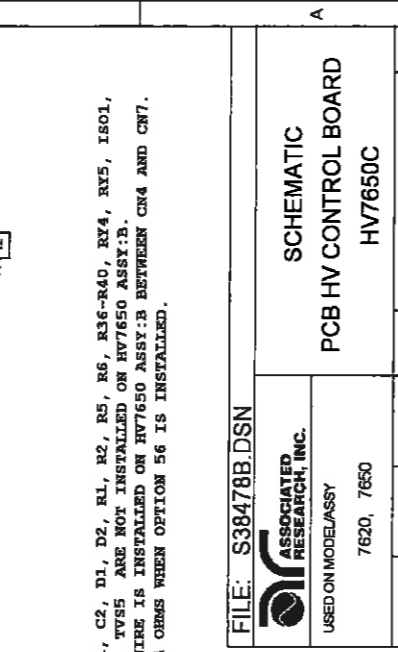
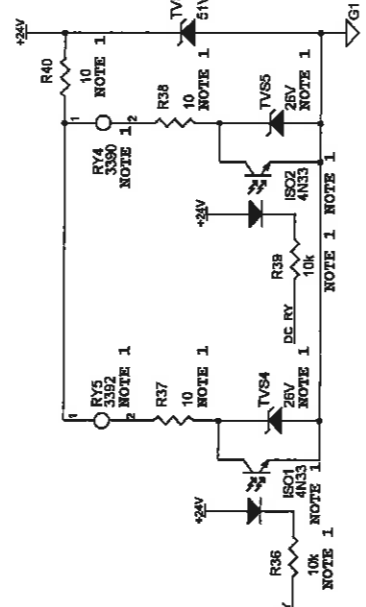
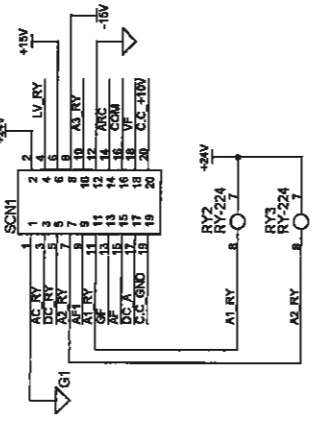

SYM	DESCRIPTION	REVISIONS	ECC#	DATE	APPR	CHK

1  
 2  
 3  
 4  
 5  
 6

1  
 2  
 3  
 4  
 5  
 6

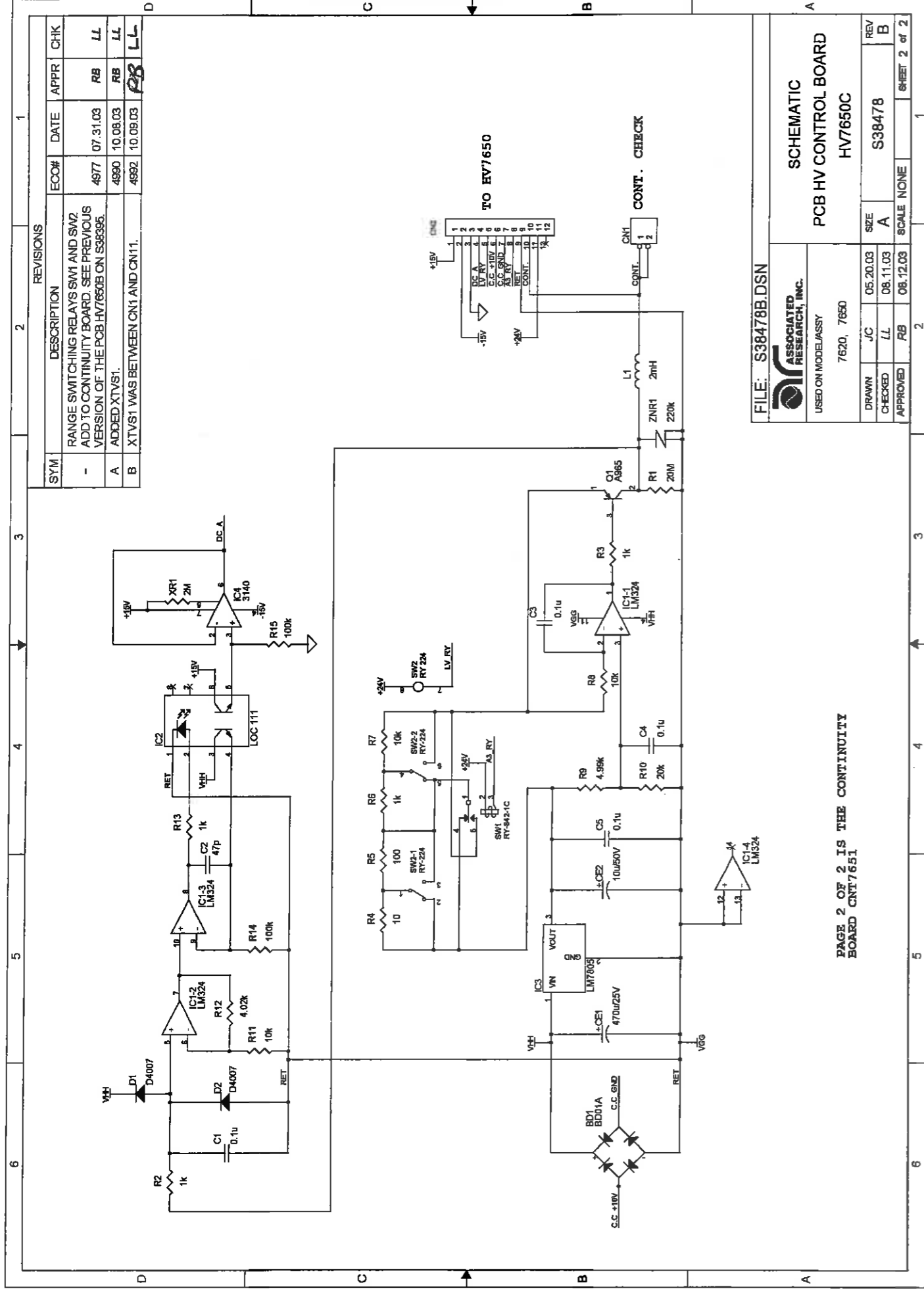

PAGE 2 OF 2 IS THE CONTINUITY BOARD CNT7651

FILE: S38478B.DSN



USED ON MODEL/ASSY

7620, 7650

DRAWN	JC	05.20.03	SIZE	A	REV	B
CHECKED	LL	08.11.03	SCALE	NONE		
APPROVED	RB	08.12.03				

### SCHEMATIC PCB HV CONTROL BOARD HV7650C

SYM	DESCRIPTION	ECO#	DATE	APPR	CHK
-	RANGE SWITCHING RELAYS SW1 AND SW2 ADD TO CONTINUITY BOARD. SEE PREVIOUS VERSION OF THE PCB HV7650C ON S38395.	4977	07.31.03	RB	LL
A	ADDED XTVS1.	4990	10.08.03	RB	LL
B	XTVS1 WAS BETWEEN CN1 AND CN11.	4992	10.09.03	RB	LL

REVISIONS	
1	

REVISIONS	
2	

REVISIONS	
3	

REVISIONS	
4	

REVISIONS	
5	

REVISIONS	
6	

REVISIONS	
1	

REVISIONS	
2	

REVISIONS	
3	

REVISIONS	
4	

REVISIONS	
5	

REVISIONS	
6	

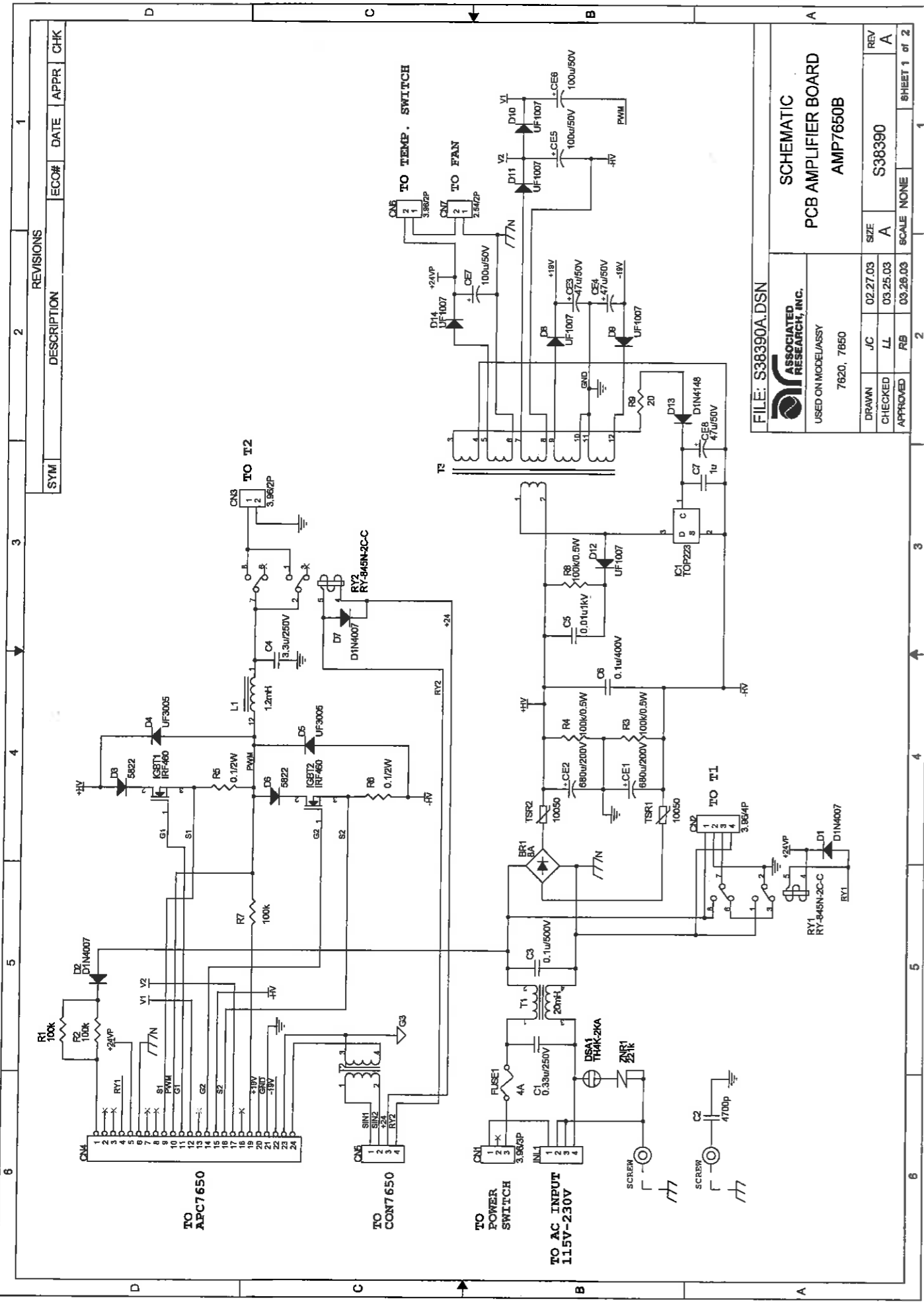

FILE: S38390A.DSN

**ASSOCIATED RESEARCH, INC.**

USED ON MODEL/ASSY  
7620, 7650

**SCHEMATIC  
PCB AMPLIFIER BOARD  
AMP7650B**

DRAWN	JC	02.27.03	SIZE	A	REV	A
CHECKED	LL	03.25.03	SCALE	NONE		
APPROVED	RB	03.28.03			SHEET	1 of 2

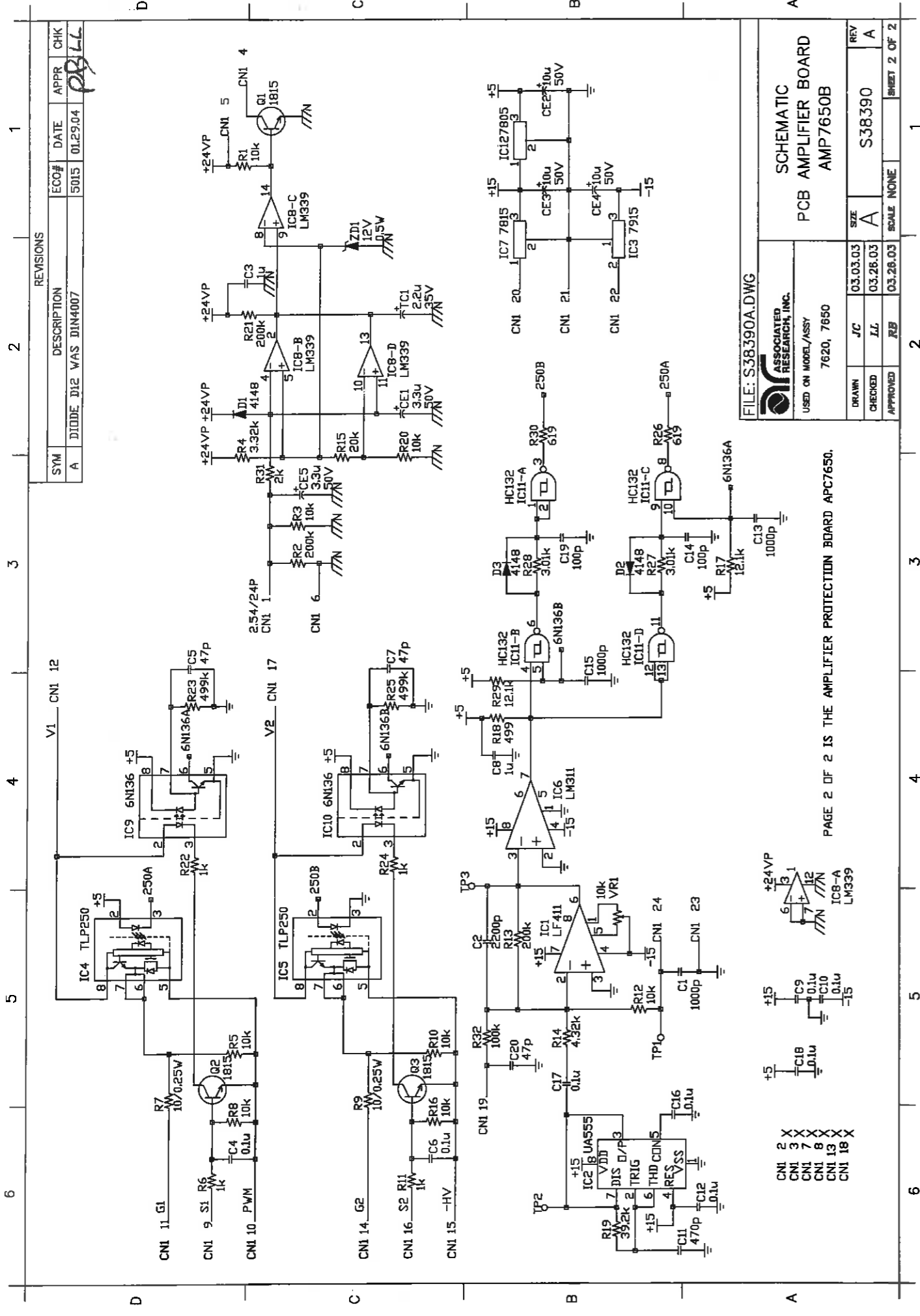

- CNI 2 X
- CNI 3 X
- CNI 7 X
- CNI 8 X
- CNI 13 X
- CNI 18 X

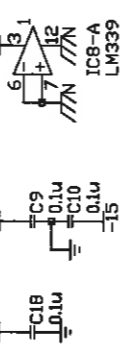

PAGE 2 OF 2 IS THE AMPLIFIER PROTECTION BOARD APC7650.

FILE: S38390A.DWG  
 ASSOCIATED RESEARCH, INC.  
 USED ON MODEL/ASSY  
 7620, 7650

SCHEMATIC  
 PCB AMPLIFIER BOARD  
 AMP7650B

DRAWN	JC	SIZE	REV
CHECKED	LZ	A	A
APPROVED	RJB	SCALE NONE	SHEET 2 OF 2

SYM	DESCRIPTION	ECO#	DATE	APPR	CHK
A	DIDDE D12 WAS DIN4007	5015	01.29.04		PRILL

REVISIONS

1

2

3

4

5

6

1

2

3

4

5

6

SYM	DESCRIPTION	ECO#	DATE	APPR	CHK

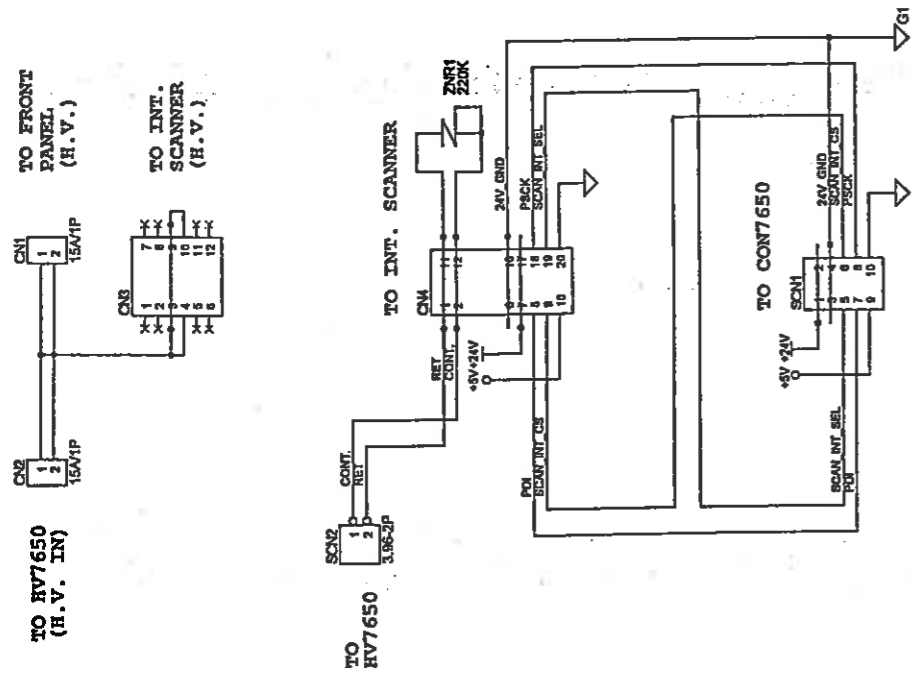

FILE: S38392.DSN

ASSOCIATED RESEARCH, INC.

USED ON MODEL ASSY  
7620, 7650

SCHMATIC  
CONNECTOR TRANSFER  
CNR7650A

DRAWN	JC	DL15.02	SIZE	A	REV	-
CHECKED	LL	3.00.03	SCALE	NONE	SHEET 1 of 1	
APPROVED	RB	3.24.03				

3

4

5

6

SYMBOL	DESCRIPTION	ECO#	DATE	APPR	CHK

REVISIONS

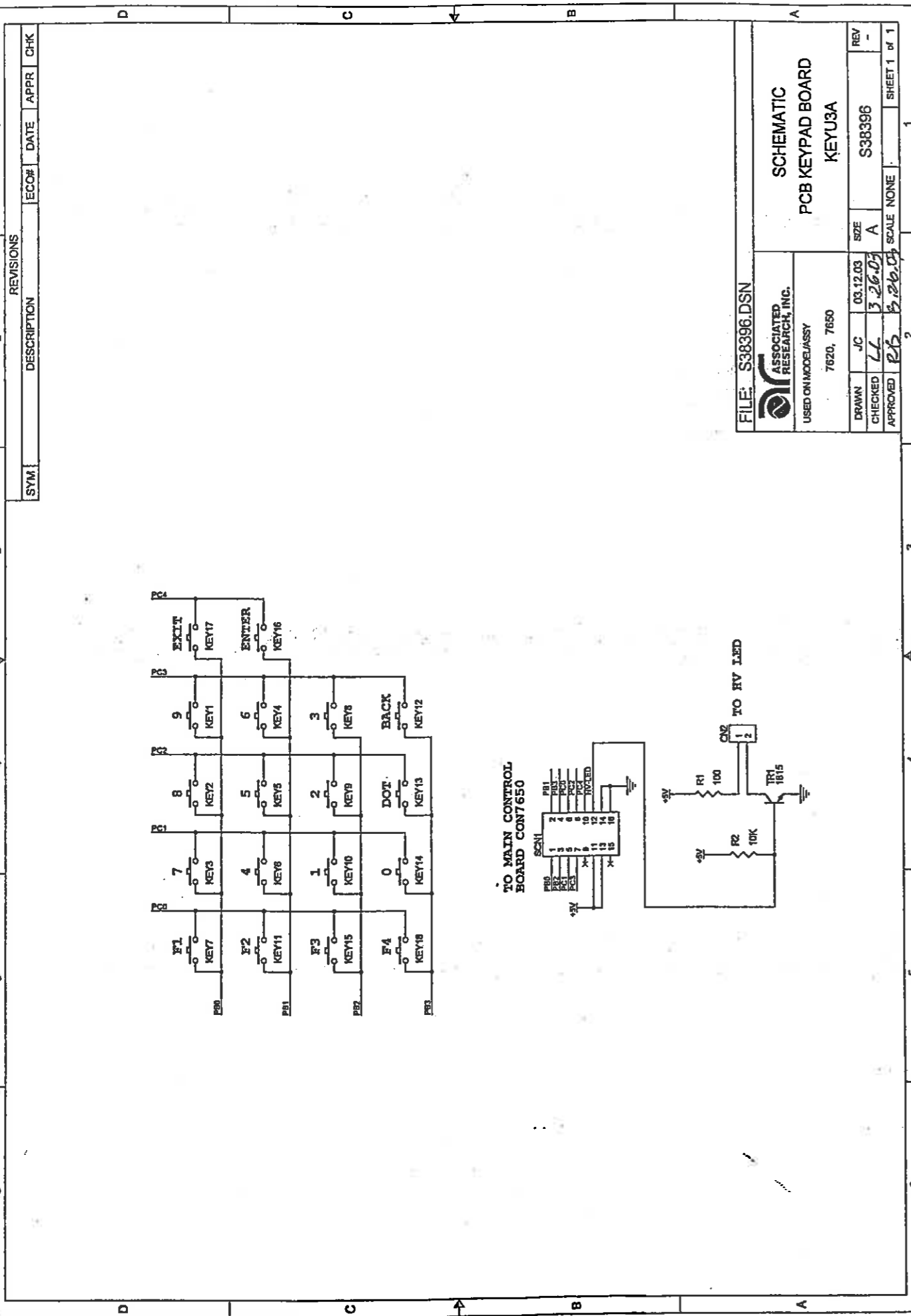

FILE: S38396.DSN

ASSOCIATED RESEARCH, INC.  
USED ON MODEL/ASSY  
7620, 7650

**SCHEMATIC  
PCB KEYPAD BOARD  
KEYU3A**

DRAWN	JC	03.12.03	SIZE	REV
CHECKED	LL	3.26.03	A	-
APPROVED	RB	5.26.03	SCALE NONE	SHEET 1 of 1

1

2

3

4

5

6





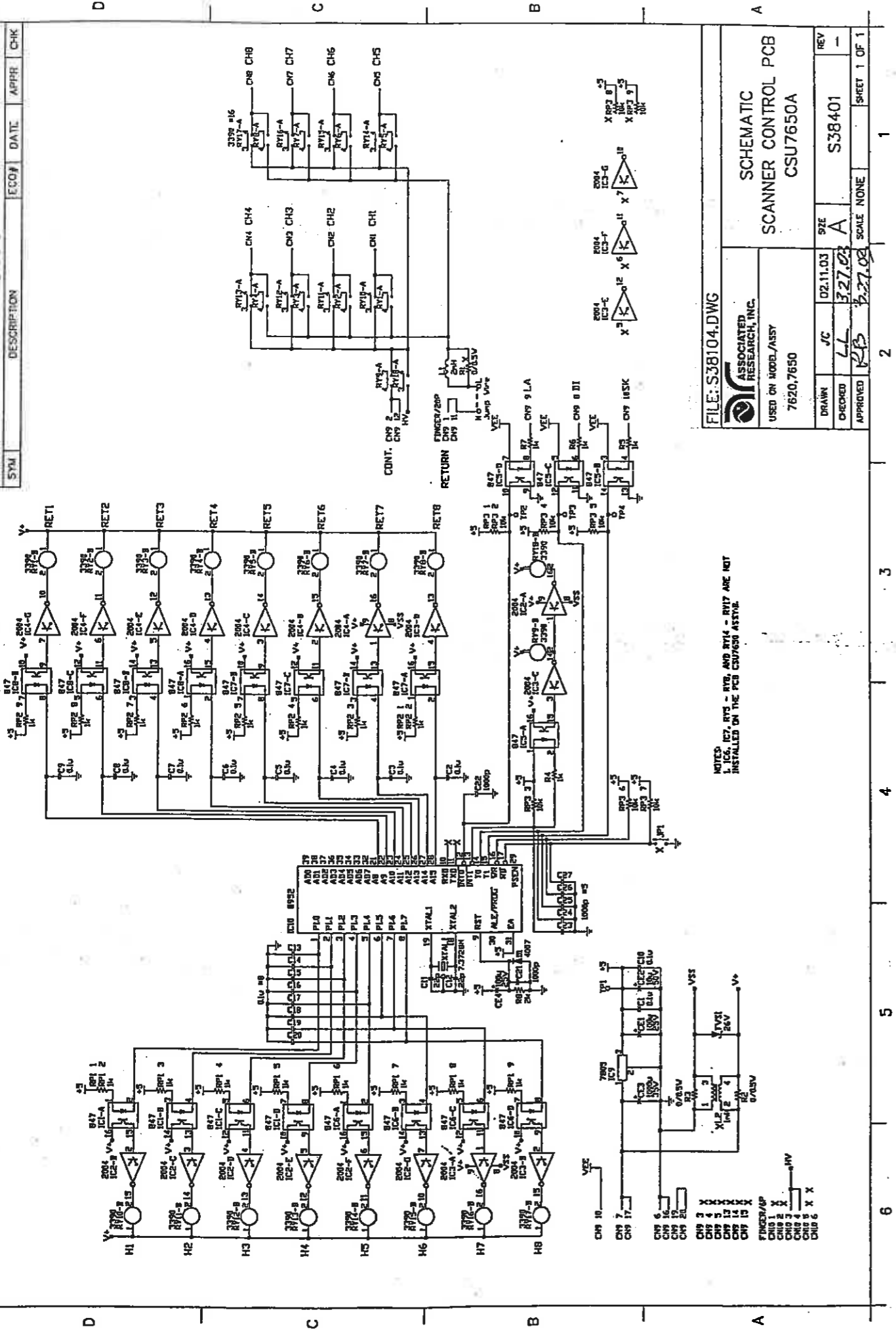

FILE: S38104.DWG  
 ASSOCIATED RESEARCH, INC.  
 USED ON MODEL/ASSY 7620, 7650

NOTES  
 1. IC6, IC7, IC5 - RV5, AND RV14 - RV17 ARE NOT INSTALLED ON THE PCB CSU7650 ASSY.

SCHEMATIC		SIZE	REV
SCANNER CONTROL PCB		A	S38401
CSU7650A		SCALE	NONE
DRAWN	JC	02.11.03	
CHECKED	LL	02.27.03	
APPROVED	RP	03.27.03	
		SHEET	1 OF 1

1 2 3 4 5 6

REVISIONS					
SYM	DESCRIPTION	ECO#	DATE	APPR	CHK
A	IC4 WAS 89C52. EXPANDED MODEL #.	4686	11.19.98	RB	LL
B	ADDED MODEL 905D.	4734	11.03.99	RB	LL
C	PCB WAS CGP-03. ADD CAPACITORS C2-C17, XC1 ADD BEED L1-L17. L18 WAS L1. R4, R7 WERE 475. R5, R6 WERE 1K. RENAME DESIGNATORS OF CAPACITORS.	4748	01.18.00	RB	LL
D	ADDED MODELS 800X AND NOTE1.	4850	10.27.01	RB	LL
E	ADDED MODELS 76XX.	-	03.26.03	RB	LL
F	CORRECTED NOTE1.	5016	01.29.04	RB	LL

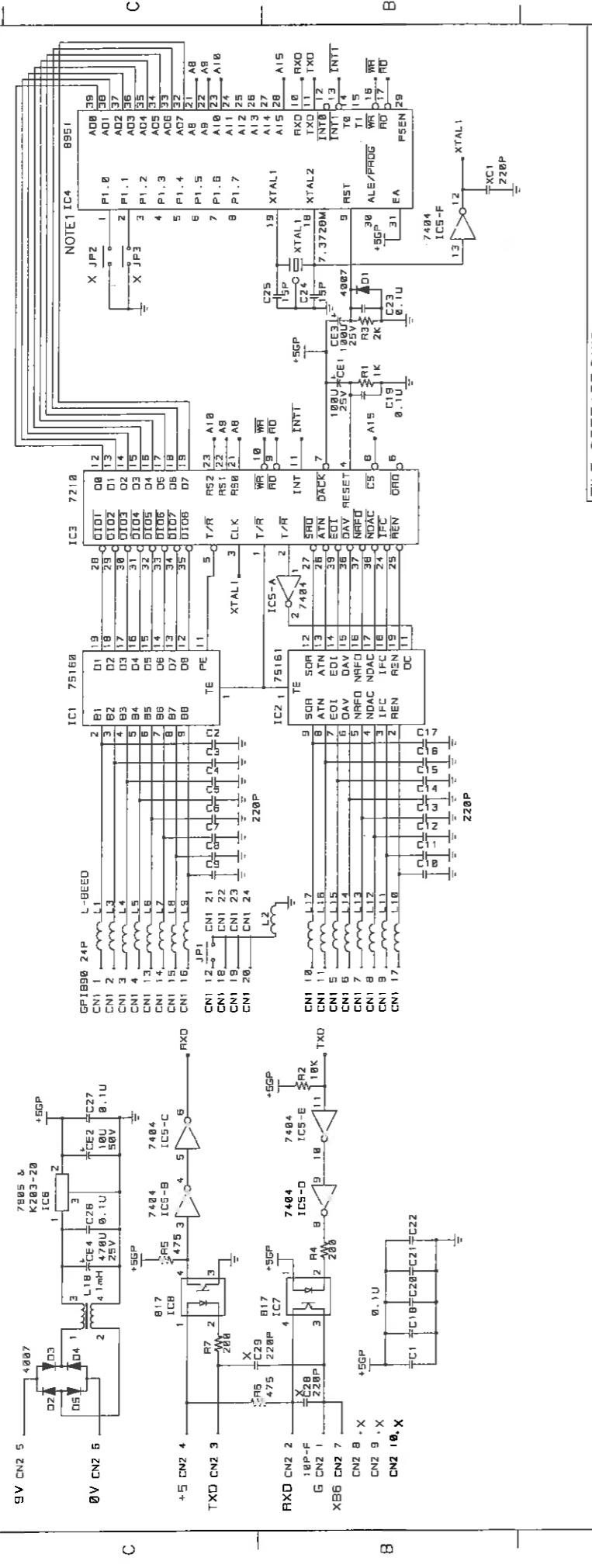

FILE: S37745F.DWG

**ASSOCIATED RESEARCH, INC.**

USED ON MODEL/ASSY  
510/20L,905D,75XX,76XX,800X

**SCHEMATIC GPIB INTERFACE CGP-03A**

DRAWN	CPY	04.11.97	SIZE	A	REV	F
CHECKED	NLT	06.04.97				
APPROVED	RB	06.04.97	SCALE	NONE	SHEET	1 OF 1

NOTES:

1. THE PCB ASSY:B USES IC 78E516B IN LOCATION OF IC4.

SYM	DESCRIPTION	ECO#	DATE	APPR	CHK
A	R4, R9 WERE 10K. EXPANDED MODEL #.	4686	11.19.98	RB	LL
B	ADDED MODEL 905D	4734	11.03.99	RB	LL
C	ADDED MODELS 800X	4850	10.27.01	RB	LL
D	ADDED MODELS 76XX		03.26.03	RB	LL

REVISIONS

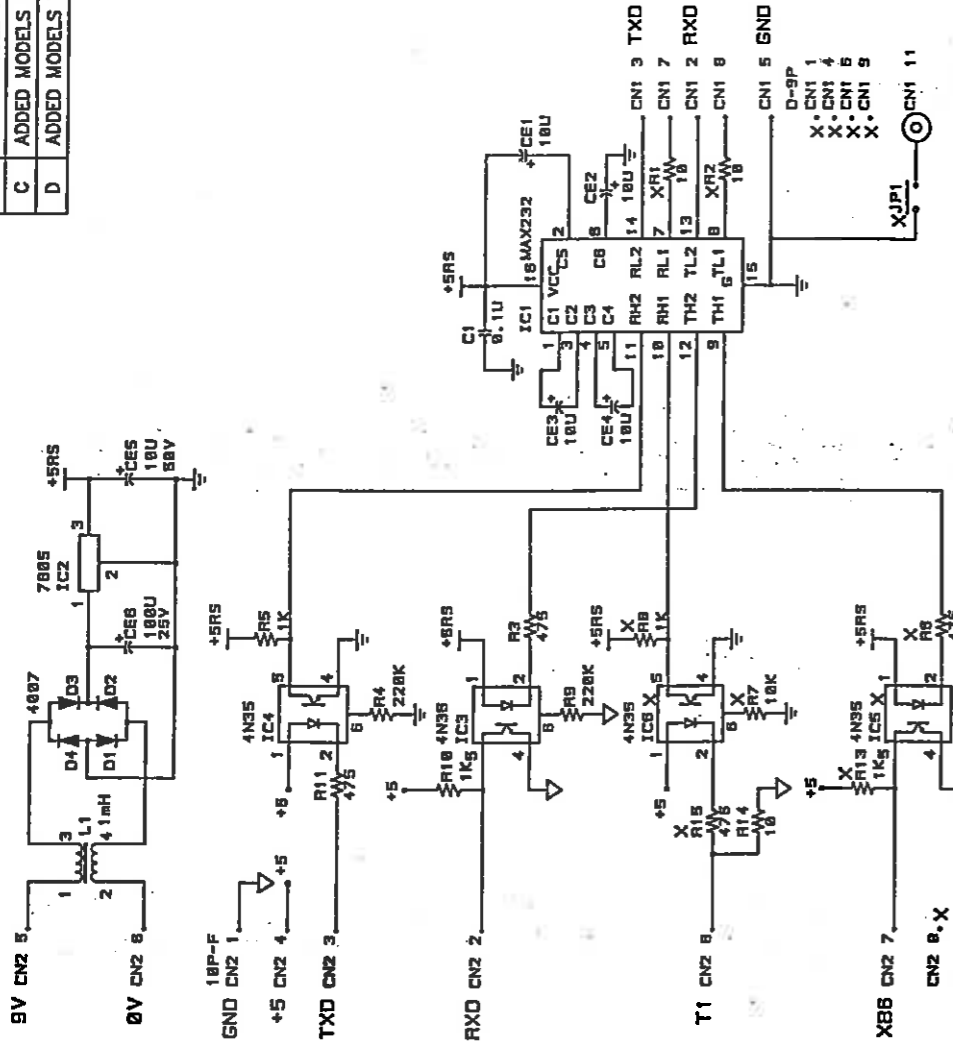

FILE: S37814D.DWG



USED ON MODEL/ASST  
510/20L, 905D, 75XX, 76XX, 800X

SCHEMATIC  
RS232 INTERFACE  
RS232A

DRAWN	CPT	DATE	SIZE	REV
		05.12.97	A	D
CHECKED	NTZ	DATE	SCALE	SHEET
		06.04.97	NONE	1 OF 1
APPROVED	RB	DATE	SCALE	SHEET
		06.04.97	NONE	1 OF 1

D C B A

1 2 3 4 5 6

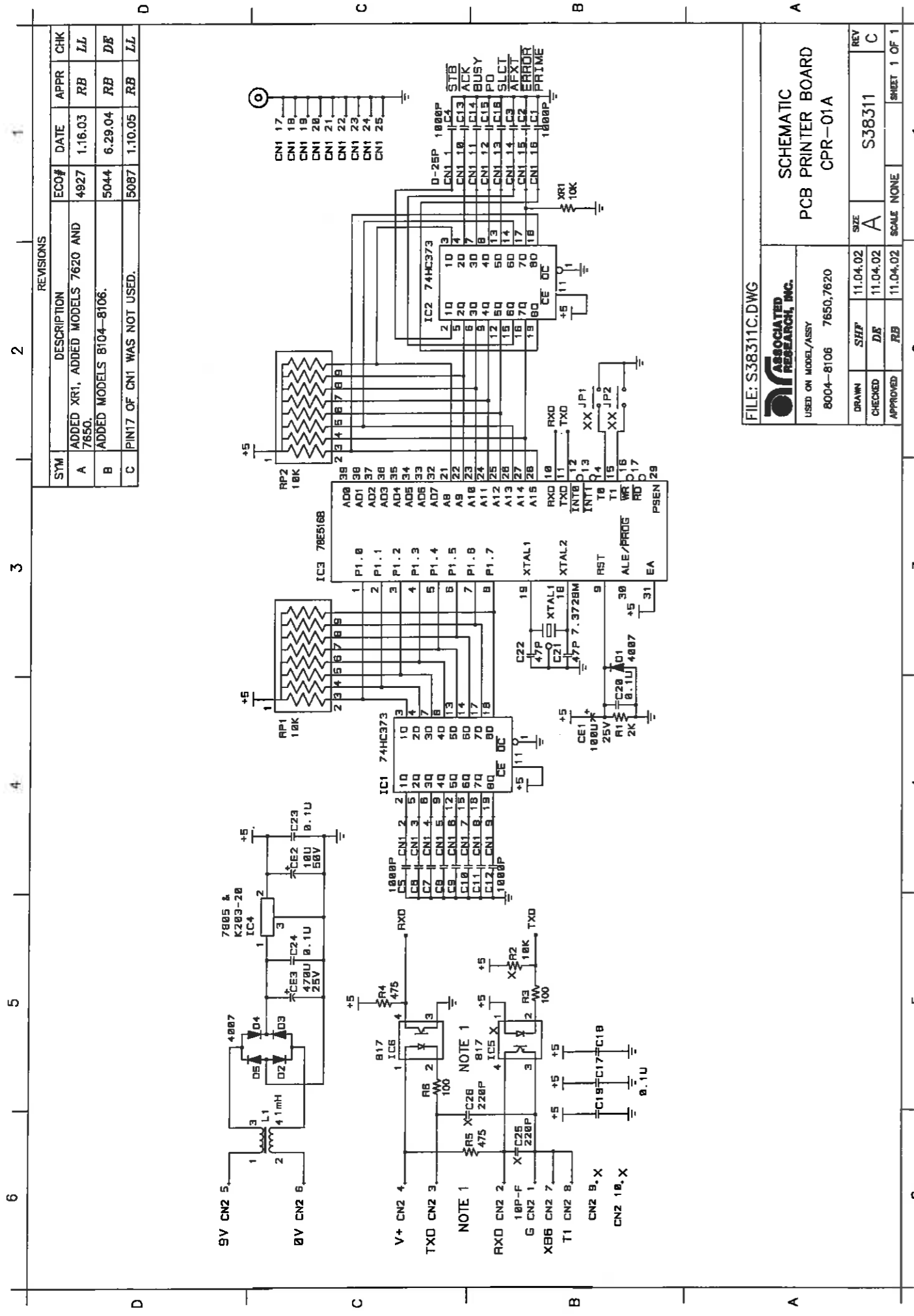

REVISIONS						
SYM	DESCRIPTION	ECO#	DATE	APPR	CHK	
A	ADDED XRI, ADDED MODELS 7620 AND 7650.	4927	1.16.03	RB	LL	
B	ADDED MODELS 8104-8106.	5044	6.29.04	RB	DE	
C	PIN17 OF CN1 WAS NOT USED.	5087	1.10.05	RB	LL	

FILE: S38311C.DWG

ASSOCIATED RESEARCH, INC.

USED ON MODEL/ASSY 8004-8106 7650,7620

DRAWN	CHKD	APPROVED	SIZE	SCALE	REV
SHP	DE	RB	A	NONE	C
					1 OF 1

SCHEMATIC  
PCB PRINTER BOARD  
CPR-01A

## Index

AC Withstand.....	46, 49, 51, 52, 53, 55, 56
Adapter Box.....	17, 26, 27, 28, 58, 113
Alarm Parameter .....	37
Arc.....	16, 31, 51, 53, 56, 64, 81, 82, 97
Benefits.....	14
Breakdown.....	3, 64
Calibration Alert.....	14
Calibration Procedure.....	101
Charge-LO.....	53, 54, 56, 57, 64, 79, 81
Connected Steps.....	33, 37, 38, 60, 61, 62, 79, 80, 85, 96, 102
Continuity Test.....	11, 14, 26, 55, 79
Contrast.....	31, 34, 37, 38, 44, 57
Controls.....	20, 26, 28, 34, 88
DC Withstand.....	52, 53, 54, 56, 64
Default Parameters.....	56, 80
Delay.....	54, 56, 63, 81, 82
Dielectric Withstand Test.....	8, 9, 31, 56, 79, 80, 81, 82, 83, 85, 90, 97
Discharge.....	7, 10, 11
Dwell.....	31, 51, 52, 56, 57, 63, 81, 82, 90, 97
Edit Parameters.....	42, 46, 48, 49, 53, 54, 55, 56, 82, 83, 92
Exit Key.....	39, 65
Fail Stop.....	37, 60, 80
Features.....	8, 14, 15
Frequency.....	9, 31, 49, 51, 55, 56, 81, 83, 97
Front Panel Controls.....	26
Glossary.....	3
GPIB.....	32, 44, 57, 75, 76, 77, 78, 84, 90, 91, 92, 99, 113, 115
Ground Bond Test.....	11
Hypot.....	3
Insulation Resistance Test.....	3, 11
Interlock.....	28, 32, 73, 84, 85, 113
LCD.....	14, 26, 37, 80, 85, 113
Leakage.....	40, 41
Applied Part.....	12
Earth.....	12
Enclosure.....	12
Line.....	12, 13, 14
Line Leakage Test.....	12
Lock.....	40
Mem Lock.....	40
Lockout.....	32, 73
Max-Lmt.....	31, 51, 52, 53, 54, 55, 56, 57, 64, 81, 82, 97, 98
Measuring Device.....	12
Medical Restrictions.....	6
Memory.....	40, 72, 77, 79, 80, 86, 87, 88, 91

Menu.....	12, 14, 30, 34, 45, 46, 66, 95
Min-Lmt.....	31, 51, 52, 54, 55, 56, 57, 64, 81, 82, 83, 97
Offset.....	16, 79
Operator.....	5, 6, 10, 14, 15, 16, 27, 30, 41, 72
Options.....	28, 43, 75, 78, 92
Parameters	
System Parameters.....	96
Test Parameters.....	49, 56, 75, 77, 79, 96
<b>Password</b> .....	39, 40, 43
PLC.....	15, 31, 34, 36, 44, 57, 72, 74
Power Factor.....	12
Programming.....	34, 75
Quickstart.....	30
Ramp-HI.....	53, 56, 81, 82
Ramping.....	63
Real Current.....	51, 61
Rear Panel Controls.....	28
Receptacle.....	18, 30, 71
Regulation.....	15
Remote.....	6, 15, 28, 31, 32, 34, 36, 44, 57, 64, 71, 72, 73, 74, 75, 76, 77, 84, 85, 99
Remote Interlock.....	32, 73, 84
Reviewing Test Results.....	39
RS-232.....	i, 28, 75, 78, 87, 90, 91, 99, 115
Run Test.....	12, 14
Safety.....	i, 2, 4, 7, 8, 18, 30
Safety Symbols.....	2
Scanner.....	14, 28, 31, 56, 57, 83, 90, 92, 97
Channel.....	51, 53, 54, 55
Internal.....	92
Option.....	92, 94
Parameter.....	49
Schematic.....	115
Setup.....	50
Status.....	93
Schematic.....	115
Schematic Index.....	115
Security.....	14, 32, 39, 40, 43, 44, 57
Sequence.....	37, 38
Service Interval.....	4
Setup.....	31, 34, 35, 44, 57
AC Withstand.....	51
DC Withstand.....	52
File.....	79, 84
Ground Continuity.....	55
Insulation Resistance.....	53
Scanner.....	50, 92, 94
System.....	95

11  
12  
13  
14  
15  
16  
17  
18  
19  
20  
21  
22  
23  
24  
25  
26  
27  
28  
29  
30  
31  
32  
33  
34  
35  
36  
37  
38  
39  
40  
41  
42  
43  
44  
45  
46  
47  
48  
49  
50  
51  
52  
53  
54  
55  
56  
57  
58  
59  
60  
61  
62  
63  
64  
65  
66  
67  
68  
69  
70  
71  
72  
73  
74  
75  
76  
77  
78  
79  
80  
81  
82  
83  
84  
85  
86  
87  
88  
89  
90  
91  
92  
93  
94  
95  
96  
97  
98  
99  
100  
101  
102  
103  
104  
105  
106  
107  
108  
109  
110  
111  
112  
113  
114  
115  
116  
117  
118  
119  
120  
121  
122  
123  
124  
125  
126  
127  
128  
129  
130  
131  
132  
133  
134  
135  
136  
137  
138  
139  
140  
141  
142  
143  
144  
145  
146  
147  
148  
149  
150  
151  
152  
153  
154  
155  
156  
157  
158  
159  
160  
161  
162  
163  
164  
165  
166  
167  
168  
169  
170  
171  
172  
173  
174  
175  
176  
177  
178  
179  
180  
181  
182  
183  
184  
185  
186  
187  
188  
189  
190  
191  
192  
193  
194  
195  
196  
197  
198  
199  
200

---

Test.....	45, 46
Short.....	33, 37, 48, 55, 60, 64
Single Step.....	31, 34, 36, 37, 44, 57, 60, 61, 98
Smart GFI.....	19, 32, 34, 40, 41, 44, 57
Specifications.....	20
System Parameters.....	34, 35, 46
Test Parameters.....	34, 35, 46
Test Screen.....	95
Test Station.....	5, 7
Trip Point.....	3
UL.....	8, 12, 66
Unpacking.....	17
Verification.....	30, 66, 67, 68, 69, 70
AC Hipot.....	68
Continuity.....	67
DC Hipot.....	69
IR.....	70
Warranty.....	1, 4, 101

---

