

OPERATION AND SERVICE MANUAL

HypotPLUS[®] II

MODEL 5500DT (AC ONLY HIPOT WITH GROUND CONTINUITY CHECK)
MODEL 5560DT (AC/DC HIPOT WITH GROUND CONTINUITY CHECK)

SERIAL NUMBER

--	--	--	--	--	--	--

Models
5500DT/5560DT

Item 37545

Ver 1.45

© Associated Research, Inc., 2003
13860 West Laurel Drive
Lake Forest, Illinois, 60045-4546
U.S.A.

Printed Oct 16, 2003



DECLARATION OF CONFORMITY

Manufacturer: Associated Research, Inc.
Address: 13860 W. Laurel Dr.
Lake Forest, IL 60045
USA
Product Name: HypotPLUS® II Dielectric Withstand
Voltage Tester
Model Number: 5500DT, 5560DT

Conforms to the following Standards:

Safety: EN 61010-1: 1993 + A2
EN 61010-031: 1994
EMC: EN 50082-1: 1992, EN 50081-1: 1992,
IEC 801-2: 1984, EN 55022: 1994,
IEC 801-3: 1984, EN 60555-2: 1987,
IEC 801-4: 1988

Supplementary Information

*The product herewith complies with the requirements of the **Low Voltage Directive 73/23/EEC as amended by 93/68/EEC** and the **EMC Directive 89/336/EEC as amended by 92/31/EEC**.*

The CE marking has been affixed on the device according to article 10 of the EMC Directive 8/336/EEC.

The technical file and other documentation are on file with Associated Research, Inc.

Joseph Guerriero
Vice President / General Manager

Associated Research, Inc.
Lake Forest, Illinois USA
May 19, 1998

WarrantyPolicies

Associated Research, Inc., certifies that the instrument listed in this manual meets or exceeds published manufacturing specifications. This instrument was calibrated using standards that are traceable to the National Institute of Standards and Technology (NIST).

Your new instrument is warranted to be free from defects in workmanship and material for a period of (1) year from date of shipment. You must complete the on-line registration at www.asresearch.com/register or call 1-800-858-TEST ext. 210 to register over the phone

5-Year Program

AR recommends that your instrument be calibrated on a twelve-month cycle. Instruments purchased and used in North America only, may have their warranty extended in one year increments to a maximum of **(5) years** provided they are returned to AR at least **annually** for calibration and inspection. The annual calibration and inspection must be performed annually every year following receipt of instrument. Any instrument not calibrated and inspected annually will not be eligible for extended warranty status. This extended warranty is non-transferable and is offered only to the original purchaser. A return material authorization (RMA) must be obtained from AR before returning this instrument for warranty service. Please contact our Customer Support Center at 1-800-858-TEST (8378) to obtain an RMA number. It is important that the instrument is packed in its original container for safe transport. If the original container is not available please contact our customer support center for proper instructions on packaging. Damages sustained as a result of improper packaging will not be honored. Transportation costs for the return of the instrument for warranty service must be prepaid by the customer. AR will assume the return freight costs when returning the instrument to the customer. The return method will be at the discretion of Associated Research.

3-Year Program

A 3-Year warranty is also available for instruments purchased and used in North America. All costs for this warranty are paid with the initial purchase and include warranty coverage, annual calibration and standard ground return freight for three years. However, unlike our 5-year program annual calibration and inspection by Associated Research is not required.

Except as provided herein, Associated Research makes no warranties to the purchaser of this instrument and all other warranties, express or implied (including, without limitation, merchantability or fitness for a particular purpose) are hereby excluded, disclaimed and waived.

Any non-authorized modifications, tampering or physical damage will void your warranty. Elimination of any connections in the earth grounding system or bypassing any safety systems will void this warranty. This warranty does not cover batteries or accessories not of Associated Research manufacture. Parts used must be parts that are recommended by AR as an acceptable specified part. Use of non-authorized parts in the repair of this instrument will void the warranty.

TABLE OF CONTENTS

SECTION I OPERATORS MANUAL.....	1
SAFETY	2
INTRODUCTION	6
SPECIFICATIONS	11
WHAT'S NEW	16
CONTROLS	18
INSTALLATION.....	23
QUICKSTART	26
OPERATION.....	29
OPTIONS	43
SECTION II SERVICE MANUAL	51
CALIBRATION.....	52
PARTS LIST.....	54
SCHEMATICS	55

SECTION 1
OPERATORS MANUAL

SAFETY PRECAUTIONS REQUIRED FOR HIGH VOLTAGE TESTING!

GENERAL:

This product and its related documentation must be reviewed for familiarization with safety markings and instructions before operation.

This product is a Safety Class I instrument (provided with a protective earth terminal).

Before applying power verify that the instrument is set to the correct line voltage (115 or 230) and the correct fuse is installed.



INSTRUCTION MANUAL SYMBOL. PLEASE REFER TO THE INSTRUCTION MANUAL FOR SPECIFIC WARNING OR CAUTION INFORMATION TO AVOID PERSONAL INJURY OR DAMAGE TO THE PRODUCT.



INDICATES HAZARDOUS VOLTAGES MAY BE PRESENT.



CHASSIS GROUND SYMBOL.



CALLS ATTENTION TO A PROCEDURE, PRACTICE, OR CONDITION, THAT COULD POSSIBLY CAUSE BODILY INJURY OR DEATH.



CALLS ATTENTION TO A PROCEDURE, PRACTICE, OR CONDITION, THAT COULD POSSIBLY CAUSE DAMAGE TO EQUIPMENT OR PERMANENT LOSS OF DATA.

A Hipot produces voltages and currents which can cause **harmful or fatal electric shock**. To prevent accidental injury or death, these safety procedures must be strictly observed when handling and using the test instrument.

SERVICE AND MAINTENANCE

User Service

To prevent electric shock do not remove the instrument cover. There are no user serviceable parts inside. Routine maintenance or cleaning of internal parts is not necessary. Any external cleaning should be done with a clean dry or slightly damp cloth. Avoid the use of cleaning agents or chemicals to prevent any foreign liquid from entering the cabinet through ventilation holes or damaging controls and switches, also some chemicals may damage plastic parts or lettering. Schematics, when provided, are for reference only. Any replacement cables and high voltage components should be acquired directly from Associated Research, Inc. Refer servicing to an Associated Research, Inc. authorized service center.

ASSOCIATED RESEARCH, INC.
13860 WEST LAUREL DRIVE
LAKE FOREST, IL., 60045 -4546 U.S.A.

☎PHONE: 1 (847) 367-4077
1 (800) 858-TEST (8378)
FAX: 1 (847) 367-4080
E-MAIL : info@asresearch.com
www.asresearch.com

Service Interval

The instrument and its power cord, test leads, and accessories must be returned at least once a year to an Associated Research authorized service center for calibration and inspection of safety related components. Associated Research will not be held liable for injuries suffered if the instrument is not returned for its annual safety check and maintained properly.

User Modifications

Unauthorized user modifications will void your warranty. Associated Research will not be responsible for any injuries sustained due to unauthorized equipment modifications or use of parts not specified by Associated Research. Instruments returned to Associated Research with unsafe modifications will be returned to their original operating condition at your expense.

TEST STATION

Location

Select an area away from the main stream of activity which employees do not walk through in performing their normal duties. If this is not practical because of production line flow, then the area should be roped off and marked for **HIGH VOLTAGE TESTING**. No employees other than the test operators should be allowed inside.

If benches are placed back-to-back, be especially careful about the use of the bench opposite the test station. Signs should be posted: "**DANGER - HIGH VOLTAGE TEST IN PROGRESS - UNAUTHORIZED PERSONNEL KEEP AWAY.**"

Power

Dielectric Voltage-Withstand Test Equipment must be connected to a good ground. Be certain that the power wiring to the test bench is properly polarized and that the proper low resistance bonding to ground is in place.

Power to the test station should be arranged so that it can be shut off by one prominently marked switch located at the entrance to the test area. In the event of an emergency, anyone can cut off the power before entering the test area to offer assistance.

Work Area

Perform the tests on a nonconducting table or workbench, if possible.

There should not be any metal in the work area between the operator and the location where products being tested will be positioned.

Position the tester so the operator does not have to reach over the product under test to activate or adjust the tester. If the product or component being tested is small, it may be possible to construct guards or an enclosure, made of a non-conducting material such as clear acrylic, such that the item being tested is within the guards or enclosure during the test, and fit them with switches so that the tester will not operate unless the guards are in place or the enclosure closed.

Keep the area clean and uncluttered. All test equipment and test leads not absolutely necessary for the test should be removed from the test bench and put away. It should be clear to both the operator and to any observers which product is being tested, and which ones are waiting to be tested or have already been tested.

Do not perform Hipot tests in a combustible atmosphere or in any area where combustible materials are present.

TEST OPERATOR

Qualifications

This instrument generates voltages and currents which can cause **harmful or fatal electric shock** and must only be operated by a skilled worker trained in its use.

The operator should understand the electrical fundamentals of voltage, current, and resistance.

Safety Procedures

Operators should be thoroughly trained to follow these and all other applicable safety rules and procedures before they begin a test. Defeating any safety system should be treated as a serious offense and should result in severe penalties, such as removal from the Hipot testing job. Allowing unauthorized personnel in the area during a test should also be dealt

with as a serious offense.

Dress

Operators should not wear jewelry which could accidentally complete a circuit.

Medical Restrictions

This instrument should not be operated by personnel with heart ailments or devices such as pacemakers.

TEST PROCEDURES

!NEVER PERFORM A HIPOT TEST ON ENERGIZED CIRCUITRY OR EQUIPMENT!

If the instrument has an external safety ground connection be sure that this is connected. Then Connect the return lead **first** for any test regardless of whether the item under test is a sample of insulating material tested with electrodes, a component tested with the high voltage test lead, or a cord-connected device with a two or three prong plug.

Plug in the high voltage test lead only when it is being used. Handle its clip only by the insulator---**never touch the clip directly**. Be certain that the operator has control over any remote test switches connected to the Hipot. Double check the return and high voltage connections to be certain that they are proper and secure.

NEVER TOUCH THE ITEM UNDER TEST OR ANYTHING CONNECTED TO IT WHILE HIGH VOLTAGE IS PRESENT DURING THE HIPOT TEST.

WARNING

When testing with DC, always discharge the capacitance of the item under test and anything the high voltage may have contacted--such as test fixtures--before handling it or disconnecting the test leads.

HOT STICK probes can be used to discharge any capacitance in the item under test as a further safety precaution. A hot stick is a nonconducting rod about two feet long with a metal probe at the end which is connected to a wire. To discharge the device under test, two hot sticks are required. First connect both probe wires to a good earth ground. Then touch one probe tip to the same place the return lead was connected. While holding the first probe in place, touch the second probe tip to the same place where the high voltage lead was connected.

KEY SAFETY POINTS TO REMEMBER:

- Keep unqualified and unauthorized personnel away from the test area.
- Arrange the test station in a safe and orderly manner.
- Never touch the product or connections during a test.
- In case of any problem, turn off the high voltage first.
- Properly discharge any item tested with DC before touching connections.

GLOSSARY OF TERMS

(as used in this manual)

Alternating Current, AC: Current which reverses direction on a regular basis, commonly in the U.S.A. 60 times per second, in other countries 50 times per second.

Breakdown: The failure of insulation to effectively prevent the flow of current, sometimes evident by arcing. If voltage is gradually raised, breakdown will begin suddenly at a certain voltage level. Current flow is not directly proportional to voltage. Once breakdown current has flown, especially for a period of time, a repeated application of voltage will often show breakdown beginning at a lower voltage than initially.

Conductive: Having a volume resistivity of no more than 10^3 ohm-cm or a surface resistivity of no more than 10^5 ohms per square.

Conductor: A solid or liquid material which has the ability to let current pass through it, and which has a volume resistivity of no more than 10^3 ohm-cm.

Current: The movement of electrons through a conductor. Current is measured in amperes, milliamperes, microamperes, nanoamperes, or picoamperes. Symbol = **I**

Dielectric: An insulating material which is positioned between two conductive materials in such a way that a charge or voltage may appear across the two conductive materials.

Direct Current, DC: Current which flows in one direction only. The source of direct current is said to be polarized and has one terminal which is always at a higher potential than the other.

Hipot Tester: Common term for dielectric-withstand test equipment.

Hypot®: Registered trademark of Associated Research, Inc., for its dielectric-withstand test equipment.

Insulation: Gas, liquid or solid material which has a volume resistivity of at least 10^{12} ohm-cm and is used for the purpose of resisting current flow between conductors.

Insulation Resistance Tester: An instrument or a function of an instrument capable of measuring resistance's in excess of 200 megohms. Usually employs a higher voltage power supply than used in ohmmeters measuring up to 200 megohms.

Leakage: AC or DC current flow through insulation and over its surfaces, and AC current flow through a capacitance. Current flow is directly proportional to voltage. The insulation and/or capacitance is thought of as a constant impedance, unless breakdown occurs.

Resistance: That property of a substance which impedes current and results in the dissipation of power in the form of heat. The practical unit of resistance is the *ohm*. Symbol = **R**

Trip Point: The minimum current flow required to cause an indication of unacceptable performance during a dielectric voltage-withstand test.

Voltage: Electrical pressure, the force which causes current through an electrical conductor. Symbol = **V**

INTRODUCTION

The importance of testing... User safety

In an era of soaring liability costs, original manufacturers of electrical and electronic products must make sure every item is as safe as possible. All products must be designed and built to prevent electric shock, even when users abuse the equipment or by-pass built in safety features.

To meet recognized safety standards, one common test is the "dielectric voltage-withstand test". Safety agencies which require compliance safety testing at both the initial product design stage and for routine production line testing include: Underwriters Laboratories, Inc. (UL), the Canadian Standards Association (CSA), the International Electrotechnical Commission (IEC), the British Standards Institution (BSI), the Association of German Electrical Engineers (VDE), the Japanese Standards Association (JSI). These same agencies may also require that an insulation resistance test and high current ground bond test be performed.

The Dielectric Withstand (Hipot) Test....

The principle behind a dielectric voltage - withstand test is simple. If a product will function when exposed to extremely adverse conditions, it can be assumed that the product will function in normal operating circumstances.

The most common applications of the dielectric-withstand test are:

- Design (performance) Testing.... determining design adequacy to meet service conditions.
- Production Line Testing.... detecting defects in material or workmanship during processing.
- Acceptance Testing.... proving minimum insulation requirements of purchased parts.
- Repair Service Testing.... determine reliability and safety of equipment repairs.

The specific technique varies with each product, but basically, during a dielectric voltage - withstand test, an electrical device is exposed to a voltage significantly higher than it normally encounters. The high voltage is continued for a given period of time.

If, during the time the component is tested, stray current flow remains within specified limits, the device is assumed to be safe under normal conditions. The basic product design and use of the insulating material will protect the user against electrical shock.

The equipment used for this test, a dielectric-withstand tester, is often called a "hipot" (for high potential tester). The "rule of thumb" for testing is to subject the product to twice its normal operating voltage, plus 1,000 volts.

However, specific products may be tested at much higher voltages than 2X operating

voltages + 1,000 volts. For example, a product designed to operate in the range between 100 to 240 volts, can be tested between 1,000 to 4,000 volts or higher. Most "double insulated" products are tested at voltages much higher than the "rule of thumb".

Testing during development and prototype stages is more stringent than production run tests because the basic design of the product is being evaluated. Design tests usually are performed on only a few samples of the product. Production tests are performed on each and every item as it comes off the production line.

The hipot tester must also maintain an output voltage between 100% and 120% of specification. The output voltage of the hipot must have a sinusoidal waveform with a frequency between 40 to 70 Hz and has a peak waveform value that is not less than 1.3 and not more than 1.5 times the root-mean-square value.

Advantages and Disadvantages of AC Testing and DC Testing....

Please check with the Compliance Agency you are working with to see which of the two type of voltages you are authorized to use. In some cases a Compliance Agency will allow either AC or DC testing to be done. However in other cases the Compliance Agency only allows for an AC test. If you are unsure which specification you must comply with please contact our **CUSTOMER SUPPORT GROUP at 1-800-858-TEST (8378)**.

Many safety agency specifications allow either AC or DC voltages to be used during the hipot test. When this is the case the manufacturer must make the decision on which type of voltage to utilize. In order to do this it is important to understand the advantages and the disadvantages of both AC and DC testing.

AC testing characteristics

Most items that are hipot tested have some amount of distributed capacitance. An AC voltage cannot charge this capacitance so it continually reads the reactive current that flows when AC is applied to a capacitive load.

AC testing advantages

1. AC testing is generally much more accepted by safety agencies than DC testing. The main reason for this is that most items being hipot tested will operate at AC voltages and AC hipot testing offers the advantage of stressing the insulation alternately in both polarities which more closely simulates stresses the product will see in real use.
2. Since AC testing cannot charge a capacitive load the current reading remains consistent from initial application of the voltage to the end of the test. Therefore, there is no need to gradually bring up the voltage since there is no stabilization required to monitor the current reading. This means that unless the product is sensitive to a sudden application of voltage the operator can immediately apply full

voltage and read current without any wait time.

3. Another advantage of AC testing is that since AC voltage cannot charge a load there is no need to discharge the item under test after the test.

AC testing disadvantages

1. A key disadvantage of AC testing surfaces when testing capacitive products. Again, since AC cannot charge the item under test, reactive current is constantly flowing. In many cases the reactive component of the current can be much greater than the real component due to actual leakage. This can make it very difficult to detect products that have excessively high leakage current.
2. Another disadvantage of AC testing is that the hipot has to have the capability of supplying reactive and leakage current continuously. This may require a current output that is actually much higher than is really required to monitor leakage current and in most cases is usually much higher than would be needed with DC testing. This can present increased safety risks as operators are exposed to higher currents.

DC testing characteristics

During DC hipot testing the item under test is charged. The same test item capacitance that causes reactive current in AC testing results in initial charging current which exponentially drops to zero in DC testing.

DC testing advantages

1. Once the item under test is fully charged the only current flowing is true leakage current. This allows a DC hipot tester to clearly display only the true leakage of the product under test.
2. The other advantage to DC testing is that since the charging current only needs to be applied momentarily the output power requirements of the DC hipot tester can typically be much less than what would be required in an AC tester to test the same product.

DC testing disadvantages

1. Unless the item being tested has virtually no capacitance it is necessary to raise the voltage gradually from zero to the full test voltage. The more capacitive the item the more slowly the voltage must be raised. This is important since most DC hipots have failure shut off circuitry which will indicate failure almost immediately if the total current reaches the leakage threshold during the initial charging of the product under test.
2. Since a DC hipot does charge the item under test it becomes necessary to discharge

the item after the test.

3. DC testing unlike AC testing only charges the insulation in one polarity. This becomes a concern when testing products that will actually be used at AC voltages. This is a key reason that some safety agencies do not accept DC testing as an alternative to AC.
4. When performing AC hipot tests the product under test is actually tested with peak voltages that the hipot meter does not display. This is not the case with DC testing since a sinewave is not generated when testing with direct current. In order to compensate for this most safety agencies require that the equivalent DC test be performed at higher voltages than the AC test. The multiplying factor is somewhat inconsistent between agencies which can cause confusion concerning exactly what equivalent DC test voltage is appropriate.

IF YOU SHOULD HAVE ANY QUESTIONS RELATING TO THE OPERATION OF YOUR INSTRUMENT CALL 1-800-858-TEST(8378) IN THE U.S.A.
--

Model 5500DT and 5560DT Functional Specifications

DIELECTRIC WITHSTAND TEST MODE

Unless otherwise stated, accuracies are relative to a laboratory standard measurement.

Descriptions	Specifications
INPUT VOLTAGE	115 / 230V selectable, $\pm 15\%$ variation 47 - 63 Hz
FUSE	115 VAC, 230VAC -- 5A slow-blo 250VAC
OUTPUT	Rating AC 0 - 5000V, 2V / step, 20mA DC 0 - 6000V, 2V / step, 6mA (5560DT only) Regulation : $\pm (1\% \text{ of output} + 5V)$
VOLTAGE SETTING	0V - Max output rating, 10 volts/step Accuracy : $\pm (2\% \text{ of Setting} + 5V)$ (relative to displayed output) Can be adjusted during operation via UP and DOWN arrow keys.
OUTPUT FREQUENCY	Model 5500DT : 50 / 60 Hz selectable 5560DT : DC and 50 / 60 Hz selectable
WAVE FORM	Sinewave, Distortion : $<1\%$ THD
RIPPLE	$<4\%$ at 6KVDC / 6mA (for model 5560DT DC mode only)
DWELL TIME SETTING	0 and 0.5 - 999.9 seconds, 0.1 second / step "0" for continuous running
RAMP TIME SETTING	0 and 0.5 - 999.9 seconds, 0.1 second / step 0 setting = .2 seconds
FAILURE SETTINGS	AC mode High limit : 0.05 - 20.00 mA, 0.01 mA / step Low limit : 0.00 and 0.05 - 20.00 mA, 0.01 mA / step Accuracy : $\pm (2\% \text{ of setting} + 0.02 \text{ mA})$ DC mode High limit : 0.02 - 6.00 mA, 0.01 mA / step Low limit : 0.00 and 0.02 - 6.00 mA, 0.01 mA / step Accuracy : $\pm (2\% \text{ of setting} + 0.02 \text{ mA})$ Arc for AC and DC mode Sensitivity range : 0-9 Arc detection : minimum duration $\leq 10 \mu\text{s}$

METERING	<p>Voltmeter (4 digits)</p> <p>Range : AC 0.00 - 5.00 KV : DC 0.00 - 6.00 KV</p> <p>Resolution : 0.01 KV</p> <p>Accuracy : \pm (2 % of reading + 10 V)</p> <p>Ammeter (4 digits)</p> <p>Range : AC 0.05 - 20.00 mA : DC 0.02 - 6.00 mA</p> <p>Resolution : 0.01 mA</p> <p>Accuracy : \pm (2 % of reading + 0.02mA)</p>						
TIMER DISPLAY	<p>Range : 0.0 - 999.9 seconds</p> <p>Resolution : 0.1 second</p> <p>Accuracy : \pm (0.1 % of reading + 0.05 seconds)</p> <p>Ramp = 0 : 0.2 seconds</p>						
DISCHARGE TIME	\leq 200 ms						
MAXIMUM CAPACITIVE LOAD DC MODE	<table> <tr> <td>1uF < 1KV</td> <td>0.08uF < 4KV</td> </tr> <tr> <td>0.75uF < 2KV</td> <td>0.04uF < 5KV</td> </tr> <tr> <td>0.5uF < 3KV</td> <td>0.01uF < 6KV</td> </tr> </table>	1uF < 1KV	0.08uF < 4KV	0.75uF < 2KV	0.04uF < 5KV	0.5uF < 3KV	0.01uF < 6KV
1uF < 1KV	0.08uF < 4KV						
0.75uF < 2KV	0.04uF < 5KV						
0.5uF < 3KV	0.01uF < 6KV						
GROUND CONTINUITY CHECK	<p>Current : DC 0.1 A \pm 0.01A, fixed</p> <p>Max. ground resistance : 1 Ω \pm 0.1Ω, fixed</p>						
PROGRAM MEMORY	10 sets						
REMOTE CONTROL AND SIGNAL OUTPUT	<p>The following input and output signals are provide through two 9 pin D type connectors;</p> <ol style="list-style-type: none"> 1. Remote control : test and reset 2. Remote recall of memory program #1, #2 and #3 3. Outputs : pass, fail and test in process 						
SECURITY	Password lockout capability to avoid unauthorized access to test set-up program.						
LINE CORD	Detachable 7 ft. (2.13m) power cable terminated in a three prong grounding plug.						
TERMINATIONS	5ft.(1.52m) high voltage and return leads (2) with clips and a standard U.S. style (NEMA 5-15) remote receptacle box for testing items terminated with a line cord. International receptacles also available.						
MECHANICAL	<p>Bench or rack mount (2U height) with tilt up front feet</p> <p>Dimensions: (w x h x d) 17 x 3.5 x 16.5in. (432 x 88 x 419mm)</p> <p>Weight: 5500DT: 20 lbs (9kgs) 5560DT: 24 lbs (11Kgs)</p>						
ENVIRONMENTAL	<p>Operating Temperature : 32° - 113°F (0° - 45°C)</p> <p>Relative Humidity - 0 to 95%</p>						
CALIBRATION	Traceable to National Institute of Standards and Technology (NIST). Calibration controlled by software. Adjustments are made through front panel keypad in a restricted access calibration mode. Calibration information stored in non-volatile memory.						

KEY FEATURES & BENEFITS OF HypotPLUS II

1. No load setup of trip current and output voltage.
This provides the operator with an easy and safe way to set trip currents and output voltages since parameters are set without the high voltage activated.
2. Storage of up to 10 different test programs.
A real benefit for manufacturers that test different products. This makes it possible to store all the various test parameters required and quickly recall them for each of the different products that needs to be tested. Program memories can also be accessed through the remote control (PLC) port so that a manufacturer can quickly toggle through the various programs without going into the set up menu.
3. All parameters for the setups can be adjusted through a simple menu driven program by using quick access front panel keys.
The easy to follow setup screens ensure that the operator correctly sets up all test parameters.
4. Tamper proof front panel controls.
This makes it possible to limit user access to the setup screens so that only authorized personnel with a security password can change test parameters. Passwords are programmable, this ensures that the required test parameters can not be tampered with.
5. Line and load regulation.
This system maintains the output voltage to within 1% from no load to full load and over the line voltage range to ensure that test results remain consistent and within safety agency requirements..
6. Posi-Test™ current sensing system.
This capability makes it possible to ensure that a test item was properly connected since the HypotPLUS II can be set to monitor minimum and maximum levels of current during a hipot test.
7. The LCD display allows monitoring of current down to 50 microamps AC and 20 microamps DC.
Many tests only allow a very low level of acceptable leakage current.
8. Electronic ramp and dwell settings.
The electronic ramp control helps keep test results consistent as well as reduces damage to sensitive products by providing a method to gradually bring up the test voltage and eliminate high voltage spikes. The dwell timer also has a count down feature so the operator can clearly see how much time is left on a test.

9. PLC remote inputs and outputs.
The standard 9 pin interfaces provide outputs for Pass, Fail, and Test in Process. Inputs include Test, Reset and Program Select. This gives the user all the basic remotes required to configure the HypotPLUS II through simple PLC relay control.
10. Front panel LCD displays test parameters and results.
A front panel LCD allows the operator to monitor the test. The display holds the results after a test item failure so that the operator can easily review the test results. Indications of short, breakdown, low fail, high fail, arc fail and continuity failure are clearly displayed.
11. Maximum output current 20 milliamps AC and 6 milliamps DC.
*This makes this instrument a **true** hipot tester with enough output current to test capacitive loads in AC mode and allows the instrument to comply with the UL “120 K ohm” requirements.*
12. Digitally controlled arc detection system.
Many tests require the monitoring of arcing levels even if they do not exceed the maximum trip current level. HypotPLUS II allows the operator to select whether low level arcs should be detected and provides the operator with the ability to digitally select and program multiple sensitivity levels. This makes HypotPLUS II flexible enough to test any product.
13. Software calibration control.
HypotPLUS II is calibrated through the front panel keypad. All calibration information is stored in non-volatile memory. This allows HypotPLUS II to be completely calibrated without removing any covers and exposing the technician to hazardous voltages.
14. User selectable output voltage frequencies of 50 or 60 hertz.
HypotPLUS II was designed for the global market. This feature makes it simple for the user to select the output frequency in the AC hipot mode so that products can be tested at the same frequency they will be used at.
15. Output voltage fine adjustment.
To make HypotPLUS II usable in all types of applications, the operator can manually bring the voltage up or down in 10 volt increments by simply pressing the up and down arrow keys. This makes it very easy to adjust the output voltage even while HypotPLUS II is in the dwell mode so you can analyze test results at different voltages.
16. Built-in Continuity test mode.
HypotPLUS II meets ground continuity test requirements called out by UL and other safety agencies.

17. Flashing high voltage indicator.
A flashing LED located directly over the high voltage terminal clearly indicates when high voltage is active to provide maximum operator safety.

18. Easily configurable into an automated test system.
HypotPLUS II comes standard with rear output connectors and rack mount handles to make it simple to build into an automated system.

19. Comes complete with a test box for products terminated in a line cord.
The standard US style receptacle box allows easy testing of hipot and continuity on line cord terminated products. As an additional benefit, termination boxes are available for testing products with line cords configured for other countries.

WHAT'S NEW IN HypotPLUS II vs. HypotPLUS

STORAGE OF UP TO 10 DIFFERENT TEST SETUPS

Allows users who test many different products to access various test setups through the keypad or through PLC remote.

MICROPROCESSOR CONTROLLED

The easy to follow menu screens ensure that the user will set all parameters through the keypad correctly. Also dedicated HOT keys for fast direct access to most parameter settings.

PLC REMOTES

Two 9 pin interfaces provide the user with all the necessary remotes required to configure HypotPLUS II through simple PLC control. Outputs include Pass, Fail, Test in Process. Inputs include Test, Reset and Program Select.

NO LOAD SETUP

This feature gives the user the ability to safely set the output voltage and trip currents without the high voltage activated.

DWELL TIMER COUNTDOWN

The countdown timer allows the user to clearly see how much time is left on the test.

TAMPER-PROOF CONTROLS

With the user programmable password, access to setup screens can be limited to authorized personnel only.

METER MEMORY

This standard feature holds results of failed tests on the LCD, allowing the user to further review test results.

DIGITALLY CONTROLLED ARC DETECTION

This provides the user with the ability to select whether low level arcs should be detected. With a range of 2-20mA peak, the HypotPLUS II can be

set to multiple sensitivity levels.

HIGHER OUTPUT CURRENT

Increased output current of 20mA in AC and 6mA in DC provide the HypotPLUS II with enough output to meet most applications.

FRONT PANEL LCD WITH ADJUSTABLE DIMMER

HypotPLUS II utilizes an enhanced LCD to display setups and test results. For easier reading of the screen, the user can set the contrast to 10 different levels using the keypad.

ALARM VOLUME CONTROL

The user can change the volume of the failure alarm to fit a variety of environments. From level 1 through 9, 0 = OFF.

FREQUENCY SELECTION

This feature allows the user to toggle between 50hz and 60hz so products can be tested at the same frequency they will be used.

FRONT PANEL CALIBRATION

By going into the restricted access calibration mode the user can calibrate the unit through the keypad with out the need to remove any panels or covers which could expose the technician to hazardous voltages.

STANDARD ACCESSORIES

A set of rack mount handles, rear output jacks and a receptacle box for testing products terminated with a line cord are standard.

10 MICROAMP READING RESOLUTION

The reading resolution on the HypotPLUS II allows the user to monitor and set trip points down to 10 microamps.

ADVANCED DIAGNOSTICS

The LCD provides the user with more information on test results. The display indicates whether the DUT failed due to Arcing, Breakdown, Excessive Leakage or a Short Circuit.

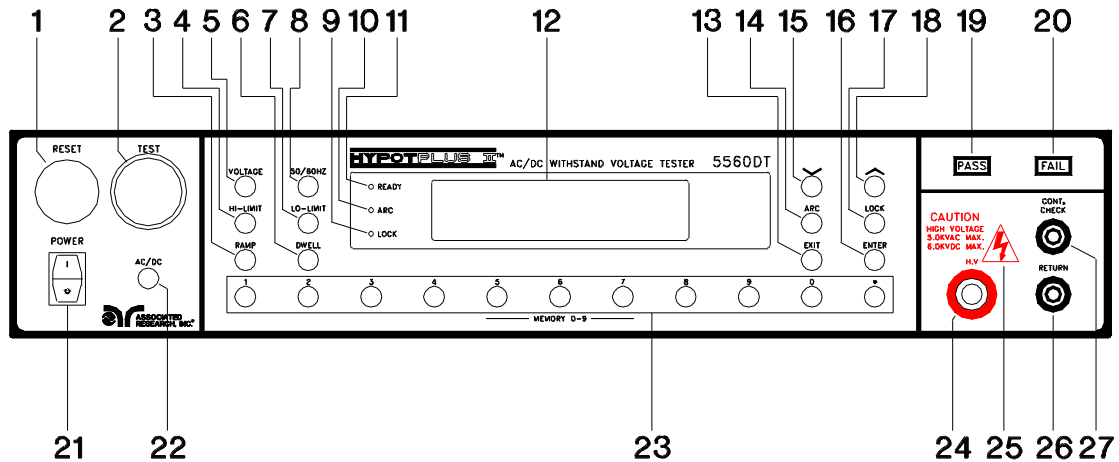
FRONT PANEL CONTROLS

1. **RESET SWITCH:** This is a momentary contact switch. If out-of-range leakage current, or an arc breakdown is detected during the hipot test or continuity failure occurs, the red Failure lamp (20) will light. To reset the system for the next test, press and release the red Reset switch (1). This switch may also be used to abort a Test in Progress.
2. **TEST SWITCH:** This is a momentary contact switch. Press the green switch to turn on the high voltage output when in test mode.
3. **RAMP KEY:** Dedicated key used to select voltage Ramp time entry. The numeric keypad (23) is used to enter the value. The Enter key (16) is used to save the new value.
4. **HI-LIMIT KEY:** Dedicated key used to select Upper leakage limit threshold entry. The numeric keypad (23) is used to enter the value. The Enter key (16) is used to save the new value.
5. **VOLTAGE KEY:** Dedicated key used to select output voltage mode entry. The numeric keypad (23) is used to enter the value. The Enter key (16) is used to save the new value.
6. **DWELL KEY:** Dedicated key used to select Test Voltage time duration entry. The numeric keypad (23) is used to enter the value. The Enter key (16) is used to save the new value.
7. **LO-LIMIT KEY:** Dedicated key used to select Lower leakage limit threshold entry. The numeric keypad (23) is used to enter the value. The Enter key (16) is used to save the new value.
8. **50/60 KEY:** Dedicated key used to enter 50/60 Hz select mode. Active only when AC mode is selected. The enter key (16) toggles from 50 to 60 Hz.

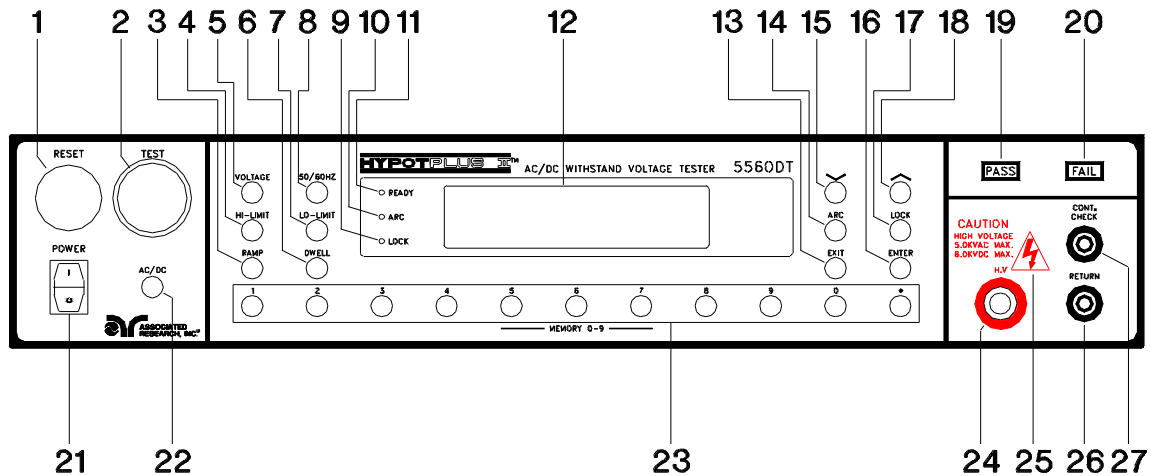
FRONT PANEL CONTROLS

9. **KEY LOCKOUT LED:** When the Key Lockout light is ON the "password" software lockout has been enabled. This means that the operator will be unable to access the "program" mode of the instrument to change any settings.
10. **ARC LED:** The Arc LED always illuminates when arcing events exceed the Arc threshold during a test.
11. **READY LED:** LED will illuminate when the system is ready to execute the next test. When the Continuity Check feature is enabled this LED will illuminate when continuity is present on the DUT.
12. **LCD DISPLAY:** The Liquid Crystal Display is the main readout for the operator and programmer of the test settings and test result.
13. **EXIT KEY:** Use this key when you desire to enter the **Run Mode** to initiate a test or use this key when you enter numeric data during a **Setup** routine and you wish to clear the information.
14. **ARC MENU KEY:** Used to enter arc menu for Arc threshold settings. Exit key moves to Arc On/Off selection mode.
15. **DOWN ARROW** ⬇: (FUNCTION KEY) Use this key to advance forward through the setup menus (continuity, remote, volume, contrast). Also may be used to decrease output voltage during a test in 10 volt increments.
16. **ENTER KEY:** Use the enter key after entering new data through the keypad to save it. This key also used to toggle ON/OFF functions.

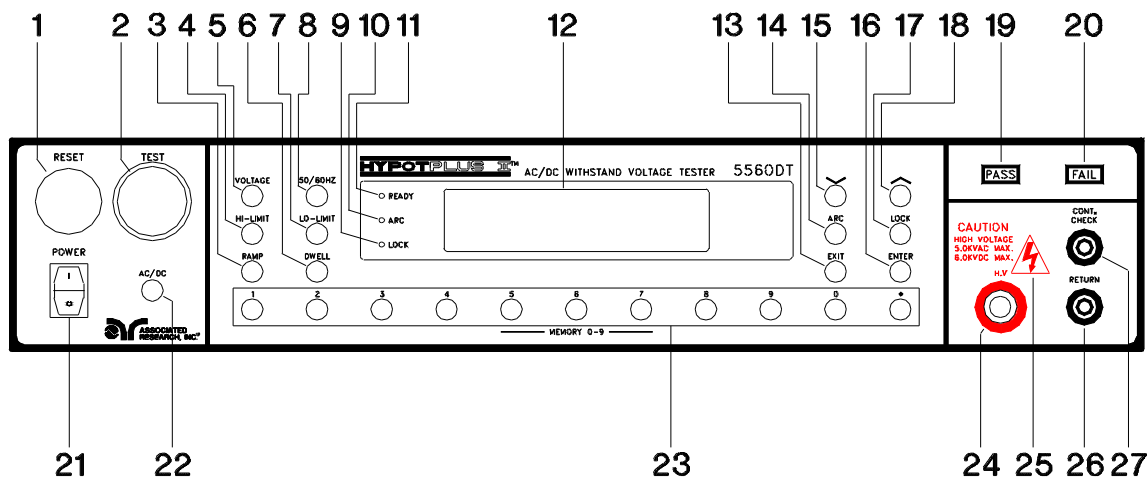
FRONT PANEL CONTROLS

17. **LOCK KEY:** Used to enter the security lock menu. This menu may or may not ask for a password depending on how the Lock function was configured in the calibration mode.
18. **UP ARROW ↑: (FUNCTION KEY)** Use this key to advance backwards through the setup menus (continuity, remote, volume, contrast). Also may be used to increase output voltage during a test in 10 volt increments.
19. **PASS LED INDICATOR:** This indicator lights at the end of a hipot test if no failure has occurred during the test.
20. **FAIL LED INDICATOR:** When a failure occurs during a hipot test or ground continuity test this indicator will light and the LCD meter will display the type of failure present such as High Current Failure, Low Current Failure, Breakdown, Short, Continuity and Arc Failure.
21. **POWER SWITCH:** Rocker-style switch with international ON (|) and OFF (0) markings.
22. **AC/DC KEY:** Dedicated key used to enter AC/DC select mode. This key available on 5560DT only. The enter key toggles from AC to DC mode.
23. **DATA ENTRY NUMERIC KEYPAD:** For numeric entry or change of testing parameters during the "Setup" mode. Keypad entry is unavailable if the "Key Lockout" indicator on the front panel is on. Press and hold one of these keys (until the second tone is heard) to store parameters in memory. Also used to recall test parameters stored in memory.

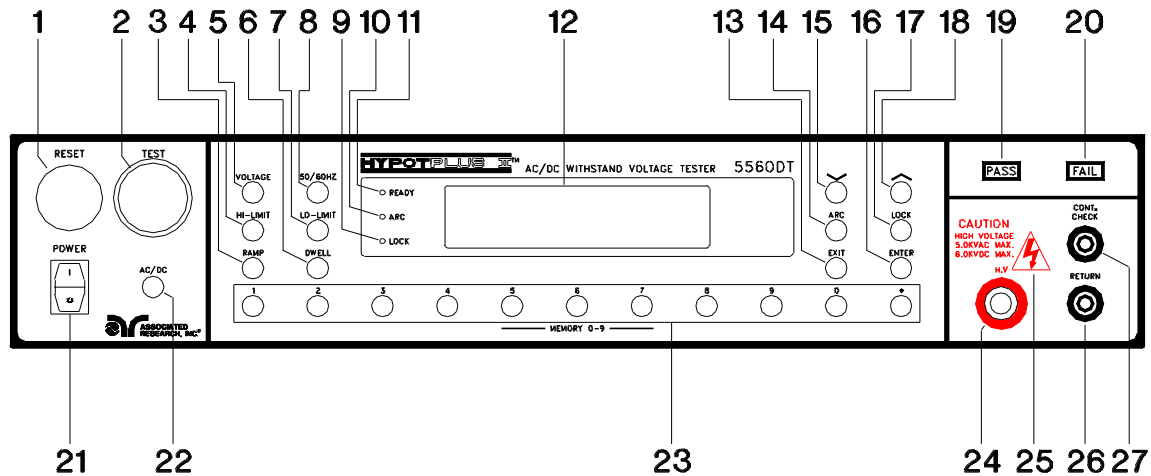
FRONT PANEL CONTROLS

24. **HIGH VOLTAGE OUTPUT JACK:** For the connection of the detachable 5 foot (1.52 m) red high voltage test lead. The silicone rubber insulation is flexible for easy handling and is rated at 30KVDC. The jack is recessed for safety when this lead is not being used.
25. **HIGH VOLTAGE ARROW (LED INDICATOR):** This indicator flashes to warn the operator that high voltage is present at the high voltage output terminal.
26. **RETURN OUTPUT JACK:** For the connection of the detachable 5 foot (1.52 m) black return test lead. This lead is always used when performing a test.
27. **CONTINUITY CHECK OUTPUT JACK:** For the connection of the detachable 5 foot (1.52 m) black return test lead. This lead is always used when performing a continuity test.

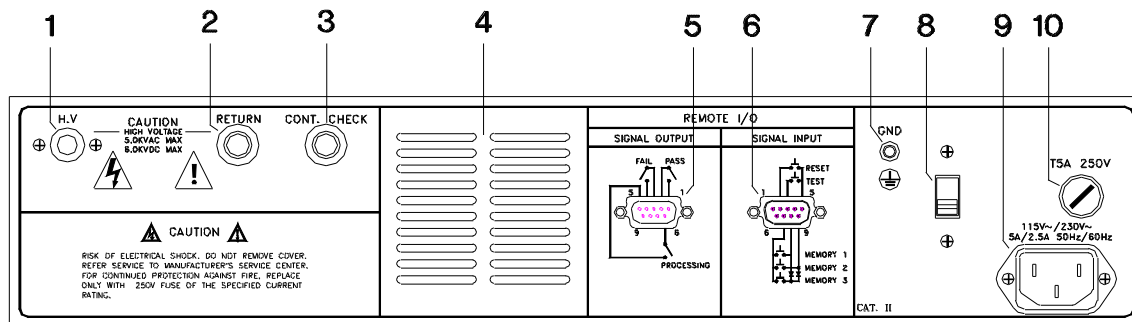
REAR PANEL CONTROLS

1. **HIGH VOLTAGE OUTPUT JACK:** For the connection of the detachable 5 foot (1.52 m) red high voltage test lead. The silicone rubber insulation is flexible for easy handling and is rated at 30KVDC. The jack is recessed for safety when this lead is not being used.
2. **RETURN OUTPUT JACK:** For the connection of the detachable 5 foot (1.52 m) black return test lead. This lead is always used when performing a test.
3. **CONTINUITY CHECK OUTPUT JACK:** For the connection of the detachable 5 foot (1.52 m) return test lead. This lead is always used when performing a continuity test.
4. **THERMAL FAN:** Runs continuously to cool the instrument.
5. **REMOTE OUTPUT:** 9 pin D subminiature female connector for monitoring PASS, FAIL, and PROCESSING output relay signals.
6. **REMOTE INPUT:** 9 pin D subminiature male connector for remote control of test and reset functions as well as program memory selection 1, 2, or 3.
7. **CHASSIS GROUND (EARTH) TERMINAL:** This safety terminal should be connected to a good earth ground before operation.
8. **INPUT POWER SWITCH:** Line voltage selection is set by the position of the switch. In the down position it is set for 115 volt operation, in the up position it is set for 230 volt operation.
9. **INPUT POWER RECEPTACLE:** Standard IEC 320 connector for connection to a standard NEMA style line power (mains) cord.
10. **FUSE RECEPTACLE:** To change the fuse unplug the power (mains) cord and turn the fuse cap counter clockwise to remove the fuse.

INSTALLATION

Introduction

This section contains information for the unpacking, inspection, preparation for use and storage of your Associated Research, Inc., product.

Unpacking and Inspection

Your instrument was shipped in a custom foam insulated container that complies with ASTM D4169-92a Assurance Level II Distribution Cycle 13 Performance Test Sequence.

If the shipping carton is damaged, inspect the contents for visible damage such as dents, scratches or broken meters. If the instrument is damaged, notify the carrier and the Associated Research customer support department immediately. Please save the shipping carton and packing material for the carriers inspection. Our customer support department will assist you in the repair or replacement of your instrument. Please do not return your product without first notifying us and receiving an RGA (return goods authorization) number.

Preparation for Use

Power Requirements and Line Voltage Selection



This instrument requires a power source of either 115 volts AC \pm 15%, 47-63 Hz single phase or 230 volts AC \pm 15%, 47-63 Hz single phase. Please check the rear panel to be sure the proper switch setting is selected for your line voltage requirements before turning your instrument on. In addition, please be sure the correct fuse is selected and installed while the instrument is in the off position.

Do not switch the line voltage selector switch located on the rear panel while the instrument is on or operating. This may cause internal damage and represents a safety risk to the operator.

NOTE

For operation at 115 Volts AC and 230 Volts AC use a 5A slow-blo fuse.

Power Cable

BEFORE CONNECTING POWER TO THIS INSTRUMENT, THE PROTECTIVE GROUND (EARTH) TERMINALS OF THIS **WARNING** INSTRUMENT MUST BE CONNECTED TO THE PROTECTIVE CONDUCTOR OF THE LINE (MAINS) POWER CORD. THE MAIN PLUG SHALL ONLY BE INSERTED IN A SOCKET OUTLET (RECEPTACLE) PROVIDED WITH A PROTECTIVE GROUND (EARTH) CONTACT. THIS PROTECTIVE GROUND (EARTH) MUST NOT BE DEFEATED BY THE USE OF AN EXTENSION CORD (POWER CABLE) WITHOUT A PROTECTIVE CONDUCTOR (GROUNDING).

This instrument is shipped with a three-wire power cable. When this cable is connected to an appropriate AC power source, this cable connects the chassis to earth ground. The type of power cable shipped with each instruments depends on the country of destination.

Test Leads

The test leads provided are designed specifically for use with this instrument. The Red High Voltage lead will mate with the white front panel connector and should only be installed when the user is completely familiar with the operation of the instrument and is ready to perform a test. The black test leads will install into the black Return and Continuity jacks. The Return lead will be used for all test but the Continuity lead is only necessary for continuity testing.

The test lead ratings are as follows:

Description	Part Number	Rating
HV output lead	04040A-08	10 KVAC, 1A
Black test leads	02100A-13	2 KVAC, 1A

Operating Environment

This instrument may be operated in temperatures from 32° - 113° F (0° - 45° C).

Relative humidity of 0 to 95%.

Altitude up to 15,000 feet (4,600 meters).

Ventillation: When choosing a bench location, or in rack mount applications, insure that there is at least 6 inches (15 cm) of space from the rear panel to any wall or obstruction behind the unit.

STORAGE AND SHIPMENT

Environment

This instrument may be stored or shipped in environments with the following limits:

Temperature..... -40° to +75°C

Altitude..... 7,620 meters (25,000 feet)

The instrument should also be protected against temperature extremes which may cause condensation within the instrument.

Packaging

Original Packaging: Please retain all original packaging materials if you do not have an alternate method of repackaging. If you are returning your instrument to us for servicing please repackage the instrument in its original container or use an alternate packaging solution. Please do not reuse the original packing material if there appears to be damage or missing packing material. Contact our customer support department (1-800-858-8378) for an RGA (return goods authorization) number. Please enclose the instrument with all options, accessories and test leads. Indicate the nature of the problem or type of service needed. Also, please mark the container "FRAGILE" to insure proper handling. Upon receipt your instrument will be issued an AR service number. Please refer to this number in all correspondence.

Other Packaging: If you do not have the original packaging materials please follow these guidelines:

- 1). Wrap the instrument in a bubble pack or similar foam. Enclose the same information as above.
- 2). Use a strong double-wall container that is made for shipping instrumentation. 350 lb. test material is adequate.
- 3). Use a layer of shock-absorbing material 70 to 100 mm (3 to 4 inch) thick around all sides of the instrument. Protect the control panel with cardboard.
- 4). Seal the container securely.
- 5). Mark the container "FRAGILE" to insure proper handling.
- 6). Please ship models 5500DT and 5560DT via Federal Express or UPS air.
- 7). Please refer in all correspondence to your AR service number.

Field Installation Of Options

There are no field installable options on the model 5500DT or 5560DT.

QUICK START

This quick start guide assumes the operator has some familiarity with automated hipot testing and desires to use the "**default**" settings on the instrument. The default settings shown will remain in memory unless you choose to override them with your own test program. The instrument default settings are as follows:

DEFAULTS

- **Input Voltage:** 115 volts AC (rear panel switch selectable)
- **Communications:** local (front panel key selectable)
- **Mode:** set-up
- **Voltage Output:** 1,240 volts AC
- **Current Trip:** W-UPPER: 10 mA
W-LOWER: 0.00 mA
- **Dwell Timer:** 1 second
- **Ramp Time:** 1 second
- **Voltage Type:** AC
- **AC Output Frequency:** 60Hz
- **Arc detection:** ON
- **Arc sensitivity:** 5
- **Continuity:** OFF
- **Buzzer:** Volume Level 5
- **Contrast:** LCD contrast level 5
- **Remote:** OFF
- **Lock:** OFF

a). Unpack this instrument from its special shipping container. Be sure to save all packaging materials in case you need to return it to the factory for service.

WARNING

b). Locate a suitable testing area and be sure you have read all safety instructions for the operation of the instrument and suggestions on the test area set-up in the SAFETY section of this manual. Locate a three prong grounded outlet. Be sure the outlet has been tested for proper wiring before connecting the instrument to it.

CAUTION

c). Check to be sure the correct input line voltage has been selected on the rear panel. Either 115 volts AC or 230 volts AC. Connect the power input plug into its socket on the rear panel of the instrument. Connect the male end of the plug to the outlet receptacle.

Please be sure that the safety ground on the power line cord is not defeated and that you are connecting to a grounded power source.

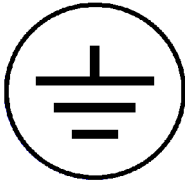

d). Turn on the POWER switch located on the lower left hand side of the front panel. Upon powering the instrument up a POWER ON SELF TEST (POST) will automatically be performed. This test will check for the condition of the ram chips, led indicators, pcb's and other critical components. All of the front panel led's will light temporarily then go out. In addition, you will see the Associated Research name and Model Number briefly appear on the LCD readout and then clear itself.

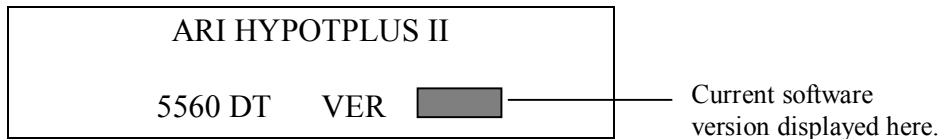

You should then see the default parameters on the LCD meter as follows:



for the following:

- SET:** This is the parameter settings review screen.
- M 1:** The instrument is using the default set ups contained in memory 1.
- 1.0 S:** The dwell timer is set to a test duration of 1 second.
- 1.24KVAC:** The test voltage is set to 1,240 volts AC.
- 10.00 mA:** The high leakage current trip point is set to 10 milliamps.

If you wish to not use any one of these parameters you must overwrite the memory 1 position or change your parameters and save them in a different memory such as memory position 2.

e). If the instrument defaults are acceptable then be sure to connect the appropriate test leads to the device under test (DUT) or test fixture. Be sure to connect this safety ground to a suitable known good ground before energizing this instrument, Then connect the return lead first (black) to the test fixture or item followed by the high voltage output lead (red).

WARNING f). Please check your connections to be sure they are making good contact and that the test station or area is clear of debris and other personnel. **DO NOT TOUCH THE DEVICE UNDER TEST ONCE THE TEST HAS BEEN STARTED.** To initiate the test press the **GREEN** test button on the front panel. This is a momentary button and does not need to be held in the pressed position during the test. The instrument will then cycle ON and begin the automated test sequence using the defaults. If a failure occurs you will **HEAR** an audible alarm go off. To stop the alarm you must depress the **RED** button marked **RESET**. This will silence the alarm and reset the instrument to begin another test. This **RESET** button may also be used as a safety button to quickly **ABORT** a test and cut off the **HIGH VOLTAGE**.

When **HIGH VOLTAGE** is present a **RED** flashing indicator located above the HV receptacle will remain flashing until the **HIGH VOLTAGE** is OFF. If the device under test **PASSED** the test then no audible alarm will sound. You will hear a brief **BEEP** to let you know the item was successfully tested and it **PASSED**. In the case of a **FAIL** condition the instrument will provide a memory of the test condition results on the LCD display that will remain until the next test is initiated. Depressing the reset button will reset the instrument alarm while keeping the last test results on the display. Depressing the reset button a second time will clear the display.



OPERATION INSTRUCTIONS FOR HypotPLUS II Model 5500DT and 5560DT

A. POWER UP:

CAUTION Check to be sure the correct input line voltage has been selected on the rear panel. Either 115 volts AC or 230 volts AC. Connect the power input plug into its socket on the rear panel of the instrument. Connect the male end of the plug to the outlet receptacle.

Please be sure that the safety ground on the power line cord is not defeated and that you are connecting to a grounded power source. Also connect the rear panel chassis ground for additional safety.

Turn on the POWER switch located on the lower left hand side of the front panel. Upon powering the instrument up a POWER ON SELF TEST (POST) will be automatically performed. This test will check for the condition of the ram chips, led indicators, pcb's and other critical components. All of the front panel led's will light temporarily then go out. In addition the display will show the following message.

```
ARI HYPOTPLUS II  
5500DT VER: X.X
```

or

```
ARI HYPOTPLUS II  
5560DT VER: X.X
```

The instrument will recall the last memory program which was active and the display will show the parameters which were programmed into that memory. The instrument is now ready for operation.

B. SETUP PROCEDURE:

1. To set the output test voltage

Please press the "Voltage" key, the display will show:

```
V o l t a g e =   X X X X   V
```

Please use the "Numerical" keys to enter the desired test voltage, then press the "Enter" key to store the voltage setting. If an incorrect value is entered, press the "Exit" key, then the correct value may be re-entered. The maximum voltage which may be entered is 5000 volts AC or 6000 volts DC. Any value above these will produce an ERROR message.

2. To set the high leakage current limit

Please press the “HIGH LIMIT” key, the display will show:

HI - L M T = XX.XX mA

Use the “Numerical” keys to enter the leakage current high limit setting, then press the “Enter” key to store the setting. The unit of measure is in milliamperes with 0.05 AC and 0.02 DC milliamperes as the minimum setting.

3. To set the low leakage current limit

Please press the “LO-Limit” key, the display will show:

LO - L M T = XX.XX mA

Please use the “Numerical” keys to enter the leakage current low limit setting, then press the “Enter” key to store the setting. If set for “0”, the low leakage current limit will be disabled. The unit of measure is in milliamperes with with 0.05 AC and 0.02 DC milliamperes as the minimum low limit current setting without disabling the low limit detector.

4. To set the dwell time

Please press the “Dwell” key the display will show:

D w e l l - T = XXX.X s

Use the “Numerical” keys to enter the dwell time setting, then press the “Enter” key to store the dwell time setting. If the dwell time is set to “0”, the instrument will operate in a continuous ON mode when the test button is depressed and released. It will stop when the DUT (Device Under Test) goes into failure or the manual reset button is pressed.

5. To set the ramp time

Please press the “Ramp” key, the display will show:

R a m p - T = XXX.X s

Use the “Numerical” keys to enter the ramp time setting then press the “Enter” key to store the ramp time setting. If the ramp time is set to “0”, the ramp up function is disabled. The minimum ramp time setting is 0.5 seconds with 0.1 second resolution.

6. To set the sensitivity of the arc detection circuit

Please press the “Arc” key, the display will show:

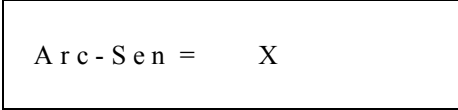

Arc-Sen = X

Use the “Numerical” keys to enter the arc sensitivity setting, then press the “Enter” key to store the arc sensitivity setting. There are ten Arc detector sensitivity settings from 0 through 9. 0 is the minimum sensitivity and 9 is the maximum sensitivity. After the “Enter” key is pressed, the display will show the following message:

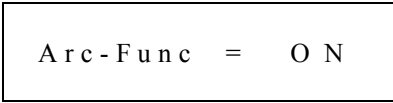

Arc-Func = ON

or

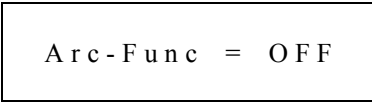

Arc-Func = OFF

Press the “Enter” key to toggle the judgment function of arc leakage current from “ON” to “OFF”, then press the “Exit” key to exit from the set mode and to go to the test mode.

If the arc sensitivity setting is satisfactory and you only want to change the judgment function, press the “Exit” key directly, then press the “Enter” key to toggle between ARC ON and ARC OFF.

In the arc “ON” position excessive arcing (over your setting) will stop the test and light the “Arc” indicator on the front panel and the alarm will sound. In the arc “OFF” position an arcing condition will light the “Arc” led indicator only, and no alarm will be indicated if the arcing was over your setting.

7. To lock or unlock the keyboard of the front panel

The HypotPLUS II is equipped with two lockout modes; one requires a password to deactivate the lockout feature the other does not require a password. Within each mode you can selectively lockout all front panel control functions except TEST and RESET or you may allow the operator to select from the pre-programmed memories.

(A). Setup of Password and Lock Functions:

To setup a PASSWORD or change the MEMORY LOCK functions you must power up the instrument in the calibration mode. To do this you must do the following:

1. Place the power switch in the off position.
2. Press and hold in the “0” key, then turn on the power switch. The display will indicate the following:

Calibration Mode
2:KV 3:mA 7:Lock

3. Press the “7” key, the display will show:

P . W . # = X X X X

or

P . W . # = 0

4. If the password is not to be changed, please press the “Exit” key. The program will go to the Memory Lock Function setting. Please refer to item “7”, listed below.

5. If a password for the Lock Function is not required, please use the numerical key to enter “0” and press the “Enter” key. The program will go to the Memory Lock Function setting.

6. If a password for Lock Function is required, please use the numerical keys to enter a four digit “Numerical Code” and press the “Enter” key. The program will go to the Memory Lock Function. Once the password is set, the password has to be entered to activate or deactivate the “Lock” function.

7. After setting the password, press the “Exit” key, the display will show:

MR - Lock = O N

or

MR - Lock = O F F

Press the “Enter” key to select Memory Lock “ON” or “OFF”.

If the MR-Lock is in the “ON” position, all the memory programs will be locked along with keyboard functions. The operator will be locked out of recalling memory programs while in the lock mode.

If the MR-Lock is in the “OFF” position, the instrument will not lock the memory programs even if the keyboard is locked. The memory programs may be recalled while in the lock mode but the test parameters within each setup cannot be changed.

- (B.) Turning the LOCK function ON or OFF with no password activated:
Press the “Lock” key, the display will show:

L o c k = O N or L o c k = O F F

Press the “Enter” key to select the “Lock (ON)” or “Unlock (OFF)” mode, then press the “Exit” key to exit and return to the test mode.

If the “Lock” mode is selected, the “Lock” indicator on the front panel will light and the keyboard will be locked. If the “Lock” indicator is not lit, the keyboard will be operational.

- (C.) Turning the LOCK function “ON” or “OFF” with a “Password”:

Press the “Lock” key, the display will show:

P . W . # = _ _

Please use the “Numerical” keys to enter the four numeral password.

If the current position of the lock function is “OFF”, the status will be changed to “ON” and the “Lock” indicator on the front panel will be illuminated. In the reverse case, the status will be changed to “OFF” and the “Lock” indicator will be off.

8. To set the AC / DC mode for MODEL 5560DT

Press the “AC / DC” key, the display will show:

M o d e = A C or M o d e = D C

Press the “Enter” key to toggle the output function; AC or DC, then press the “Exit” key to exit from the setting mode, and to return to the test mode.

9. To setup the Ground Continuity Check, Remote Control, LCD Contrast, and Alarm Volume

(A). Ground Continuity Check

Press the “UP” or “DOWN” arrow key to toggle the programs until the display shows:

C o n t i n u i t y = O N	o r	C o n t i n u i t y = O F F
-------------------------------	-----	---------------------------------

Press the “Enter” key to select the “ON” or “OFF” function of the Ground Continuity Check mode, the display will show the set status immediately.

Press the “Exit” key to exit to the test mode or toggle to another setting using the arrow keys.

If the Continuity Function is set to “ON”, the Ground Continuity cable has to be connected between the “Cont. Check” connector on the instrument panel and the chassis of the DUT. The instrument will test the ground connection of the DUT automatically. If continuity is present the “Ready” indicator will be illuminated and the operator may proceed with the hipot test. The HypotPLUS II will continue to test the ground connection of the DUT during other tests. If no continuity is present while the operator tries to initiate a test, the instrument will signal a continuity failure.

(B). Status of Remote Control setting

Press the “UP” or “DOWN” arrow key to toggle the programs until the display shows:

R e m o t e = O N	o r	R e m o t e = O F F
-----------------------	-----	-------------------------

Press the “Enter” key to select the “ON” or “OFF” function of the Remote Control mode, the display will show the status immediately.

Press the Exit key to exit to the test mode or toggle to another setting using the arrow keys.

If the Remote Control is set to “ON”, the “Test” function will be controlled by the “Remote Control” via the remote connectors located on the rear panel. The

“Test” switch on the front panel is locked out, but the “Reset” switch will still be functional. If the Remote Control is set to “OFF”, the operation will be controlled by the “Test” and “Reset” switches on the front panel.

(C). LCD Contrast setting

Press the “UP” or “DOWN” arrow keys to toggle the programs to the display shown:

C o n t r a s t = X

Please use the “Numerical” keys to enter the range of Contrast, from “0” to “9”. Then press the “Enter” key to store the Contrast range. A total of 10 ranges are available. The LCD will change the Contrast immediately and the display will show the set value on the screen. The Contrast number “0” is the weakest and “9” is the strongest. Toggle the arrow keys to another setting or press the “Exit” key to exit from the setting mode and enter the testing mode.

(D). Alarm volume setting

Press the “UP” or “DOWN” key to toggle the programs until the display shows:

B u z z e r = X

Use the “Numerical” keys to enter the range of alarm volume from “0” to “9”. A total of 10 levels. Then press the “Enter” key to store the selected alarm volume setting. The instrument will emit a tone signal as a sample of the alarm volume selected and the LCD screen will show the set point immediately. Level

“0” will turn off the alarm. Level “1” produces the lowest volume and level “9” is the loudest.

Press the “EXIT” key to exit to the test mode or toggle to another program using the arrow keys.

10. To store and recall the memory programs

HypotPLUS II is equipped with a total of 10 memory programs numbered 0 to 9. This makes it possible to store all the various test parameters required, and quickly recall them for each of the different products that need to be tested. Program memories can also be accessed through the remote control (PLC) port so that a manufacturer can quickly toggle through the various programs without going into the setup menu.

(A). Storage of Memory Program

Once you have entered all the test parameters such as Voltage, HI Limit Trip Current, Ramp Time , Dwell Time, etc., as outlined in the above procedures you may store your setup into one of the 10 memories. The display will show:

S e t M _ _ X X X . X s X . X X K V A C X X . X X m A
--

Select one of the memory positions “0” to “9” to store the data which was just entered. This is done by pressing and holding a “Numerical” key in for approx., 2 seconds. HypotPLUS II will respond with two beep tones, one short tone when you select the key and one longer tone when the data is stored into that memory position. Please select the correct memory position as you may inadvertently overwrite a previously stored program.

The display will show:

S e t M X X X X . X s X . X X K V A C X X . X X m A
--

(B). Recall of a Memory Program

Please press the “Numerical” key of the Memory Program that you wish to recall. The instrument will respond with a short beep tone and the display will indicate the test parameters stored in that program. To start a test press the “TEST” key.

C. OPERATING PROCEDURES:

1. Please follow the **Setup Procedures** to set the general status of Ground Continuity, Remote Control, LCD Contrast and the Alarm Volume.

If the instruments defaults are acceptable then be sure to connect the appropriate test leads to the device under test (DUT) or test fixture. Be sure to connect the safety ground (on the rear panel) to a suitable known good ground before energizing this instrument. Then connect the return lead first to the test fixture or the DUT followed by the high voltage lead.

Check your connections to be sure they are making good contact and that the test station or area is clear of debris or other personnel. **DO NOT TOUCH THE DEVICE UNDER TEST ONCE THE TEST HAS BEEN STARTED.**

WARNING

2. If you are performing a Ground Continuity Check the Ground Continuity must be set to the “ON (Enabled)” position. The ground check cable has to be connected properly to the chassis of the DUT and the “Cont. Check” indicator (READY LIGHT) should be illuminated before activating the “Test”

switch. Otherwise, the instrument will signal a *continuity failure* when the test switch is activated.

The display will show:

C O N T . M X X X X . X s - - - - K V A C - - - - m A

If you are not performing a “Ground Continuity Check” the Ground Continuity must be set to the “OFF” (Disabled) position. It is not necessary to connect the “Cont.Check” cable since this test will not be performed if the circuit is disabled. The instrument will proceed with the Hipot Test when the “Test” switch is activated.

3. Please follow the setup procedures to set or recall setups from memory programs. The display will show the number of the “Memory Program”, time of “Dwell”, value of “Test Voltage” and the value of the “High Limit Leakage Current” as follows:

S e t M _ X X X . X s X . X X K V A C X X . X X m A	or	S e t M X X X X . X s X . X X K V A C X X . X X m A
---	----	---

If the set data is to be stored in the memory program, please follow the procedure outlined in the setup procedures on **Storage of Memory Program**.

4. To initiate a test press the “Test” switch on the front panel. If the ramp time is set, the red “High Voltage” symbol will flash and the display will immediately show:

R a m p M X X X X . X s X . X X K V A C X X . X X m A

The instrument will output the set voltage from 0V to the set voltage according to the ramp time selected. The instrument starts to test the DUT from ramp up. When the ramp up cycle is completed, the instrument will go directly to dwell.

5. If the ramp time is set for “0”, the display will show:

D w e l l M X X X X . X s X . X X K V A C X X . X X m A

The instrument will continue to output the set dwell voltage for the duration of the selected dwell time. The count down timer will display the time remaining on the test.

NOTE: If the alarm volume is set to “0” (OFF), no audible alarm will be heard

during a failure condition.

6. If there is a short circuit in the DUT during the test, the red “FAIL” symbol will illuminate and an alarm will sound. The display will show:

```
Short   M X  XXX.X s  
X.XX K V A C  O F L  m A
```

7. If a flash over occurs in the DUT during the test, which results in an OFL condition due to the current exceeding the maximum metering range, Breakdown will be indicated as follows. The red “FAIL” symbol will illuminate and the alarm will sound. The display will show:

```
BRKDWN M X  XXX.X s  
X.XX K V A C  O F L  m A
```

8. If the leakage current exceeds the metering range and neither a short circuit nor flash over occurred, the red “FAIL” symbol will illuminate and the alarm will be activated. The display will show:

```
HI-LMT M X  XXX.X s  
X.XX K V A C  O F L  m A
```

9. If the leakage current exceeds the high limit setting, but does not exceed the metering range, the red “FAIL” symbol will illuminate and the alarm will sound. The display will show:

```
HI-LMT M X  XXX.X s  
X.XX K V A C  XX.XX m A
```

10. If the leakage current does not exceed the low limit setting, the red “FAIL” symbol will illuminate and the alarm will sound. The display will show:

```
LO-LMT M X  XXX.X s  
X.XX K V A C  XX.XX m A
```

11. If there is an arcing condition over the Arc sensitivity limit, the red “FAIL” symbol will illuminate and the alarm will sound. The display will show:

Arc	MX	XXX.Xs
X.XXK V A C	XX.XX	mA

12. To stop the alarm, please press the “RESET” switch once. The alarm will stop and the display will retain the failure information. If the “Reset” switch is pressed again, the data on the display screen will be cleared and the display will indicate the setting data from the last test. The instrument is now ready for the next test.

13. If the DUT passed all of the tests, the green “PASS” symbol on the front panel will illuminate and the instrument will output a short audible beep tone to indicate the DUT has passed the tests. The “Ready” light will also illuminate and the display will show:

Pass	MX	XXX.Xs
X.XXK V A C	XX.XX	mA

The instrument is now ready to perform another test.

14. If the operator elects to abort a test in process this can be accomplished by pressing the “Reset” switch at anytime. The instrument will stop the test process immediately and the display will show:

Abort	MX	XXX.Xs
X.XXK V A C	XX.XX	mA

Please press the “Test” switch to initiate another test.

D. CONNECTION OF REMOTE I/O:

Two 9 pin “D” type connectors are mounted on the rear panel which provide REMOTE-INPUT-OUTPUT control and information. These connectors mate with standard 9 pin “D” subminiature connector provided by the user. The output mates to a male (plug) connector while the input mates to a female (receptacle) connector. For best performance a shielded cable should be used. To avoid ground loops the shield should not be grounded at both ends of the cable. Suggested AMP part numbers for interconnecting to the Remote I/O are shown below.

205204-4 PLUG SHELL WITH GROUND INDENTS

205203-3 RECEPTACLE SHELL

745254-7 CRIMP SNAP-IN PIN CONTACT (for plug)

745253-7 CRIMP SNAP-IN SOCKET CONTACT (for receptacle)

745171-1 SHIELDED CABLE CLAMP (for either plug or receptacle)

747784-3 JACKSCREW SET (2)

REMOTE INTERFACE REAR PANEL:

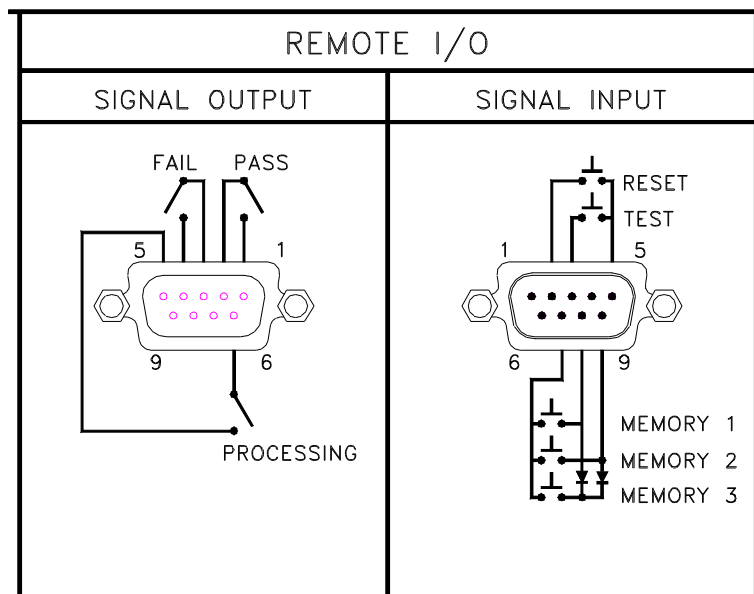
1. SIGNAL OUTPUTS ON REMOTE I/O

The rear panel connector provides output signals to remotely monitor PASS, FAIL, and PROCESSING conditions. These signals are provided by three normally open internal relays that switch on to indicate the current condition of the tester. These are normally open free contacts and will not provide any voltage or current. The ratings of the contacts are 1A / 250 VAC (0.5 ADC). The signal outputs are provided on the 9 pin female type D connector. Below is a listing that indicates what conditions activate each pin. When a terminal becomes active the relay closes thereby allowing the external voltage to operate an external device.

Pins 1 and 2 provide the PASS signal.
Pins 3 and 4 provide the FAIL signal.
Pins 5 and 6 provide the PROCESSING signal.
Pins 7, 8, and 9 are blank.

The following describes how the relays operate for each test condition.

PROCESSING - The relay contact closes the connection between pin (5) and pin (6) while the instrument is performing a test. The connection is opened at the end of the test.

PASS - The relay contact closes the connection between pin (1) and pin (2) after detecting that the item under test passed all tests. The connection is opened when the next test is initiated or the reset function is activated.

FAIL - The relay contact closes the connection between pin (3) and pin (4) after detecting that the item under test failed any test. The connection is opened when the next test is initiated or the reset function activated.

2. SIGNAL INPUTS OF REMOTE I/O AND MEMORY PROGRAMS

The HypotPLUS II remote connector enables remote operation of the TEST and RESET functions or allows the operator to select one of three pre-programmed test. When the remote function is (ON) the test switch on the front panel will be disabled to prevent a test from being activated through the test switch. A normally open momentary switch can then be wired across pins 3 and 5 to allow remote operation of the TEST function. A normally open momentary switch can also be wired across pins 2 and 5 which allows remote operation of the RESET function. For safety the front panel RESET switch remains active even when a remote reset switch is connected so that high voltage can be shut down from either location.

The HypotPLUS II also allows access to three MEMORY PROGRAMS through the remote control connector. This gives the user the capability to quickly change parameters and initiate a test remotely. The HypotPLUS II basically operates in a PLC mode by responding to simple switch or relay contact closures, the built in memory programs of the instrument are used to accomplish this. Three internal memory programs can be accessed, by connecting terminals 7, 8 and 9 in different combinations the user can select the correct memory program.

ACTIVATING MEMORY PROGRAM FUNCTIONS THROUGH THE REMOTE CONNECTOR, SELECTS THE PROGRAM, AND STARTS THE TEST THAT IS PREPROGRAMMED INTO THAT MEMORY

WARNING

DO NOT CONNECT VOLTAGE OR CURRENT TO THE SIGNAL INPUTS, THIS COULD RESULT IN DAMAGE TO THE CONTROL CIRCUITRY.

CAUTION

MEMORY ONE - Momentarily connecting terminal 7 to 8 signals the instrument to immediately begin the test program that is stored in memory one.

MEMORY TWO - Momentarily connecting terminal 7 to 9 signals the instrument to immediately begin the test program that is stored in memory two.

MEMORY THREE - Momentarily connecting terminal 7 to terminals 8 and 9 signals the instrument to immediately begin the test program that is stored in memory three.

E. ADAPTER BOX CONNECTION:

The following diagram shows how to connect the adapter box to the HypotPLUS II and to the device under test.

5500DT and 5560DT

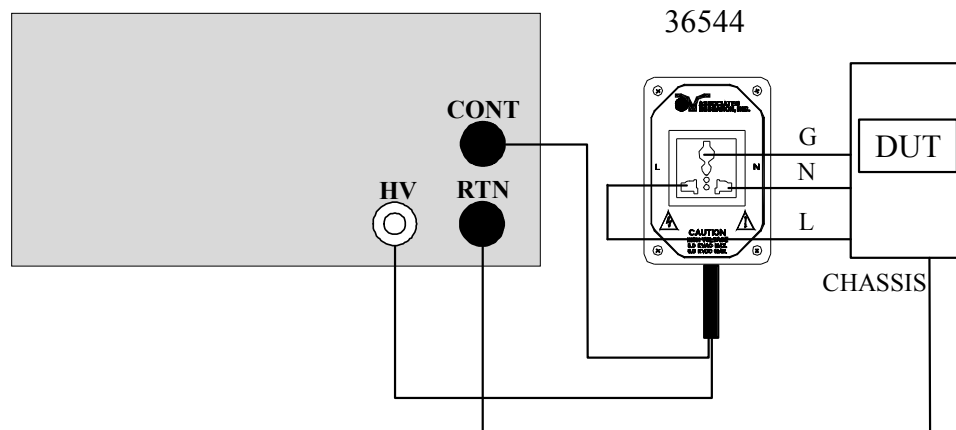

Test Connections

The adapter box allows you an easy way to connect an item which is terminated in a two or three prong line cord. If you are testing a product which is terminated in a three prong plug, you are also required to perform a continuity or ground bond test on the ground conductor of the DUT to the chassis or dead metal of the product. With the HypotPLUS II, you can perform both the hipot and continuity tests at the same time by activating the continuity function on the instrument.

When the HypotPLUS II tests the ground conductor of the line cord, if the resistance of the ground conductor exceeds 1Ω , the hipot will signal a continuity failure. If continuity is present, high voltage is applied to both conductors of the line cord to insure that all current carrying conductors in the primary circuit are tested. When testing products with two prong plugs, do not activate the continuity circuit.

MODEL 5500DT / 5560DT OPTIONS

Introduction

This section contains a list and descriptions of available factory installed options at the time of this printing.

Option Label

If your instrument has been modified with options, there will be an option label on the rear panel of the unit. The option label contains an option(s) code that may be cross-referenced to the Options List.

For example your options code would appear as follows:

fitted with option 01 OPT: 01
fitted with option 01 and 02..... OPT: 0102

5500DT / 5560DT Options

Option List

Code	Description
01	10 Volt Analog Interface
02	5mA Output
03	Real Current (AC ONLY)
04	8KVAC @ 10mA (AC ONLY)
07	Remote Interlock
08	7 Remote Memories Select

Description

01 10 Volt Analog Interface (For a description of standard remote I/O see page 40).

The 10 Volt Analog Interface option allows the user to remotely set the Voltage applied to the item under test and measure the actual test voltage and leakage current during the test.

Voltage Input

When the V-Set select contacts (pins 4 and 6) are connected menu driven voltage setting is disabled. The output voltage is controlled by the voltage applied to the Remote Voltage Set inputs (pins 1 and 6). A 0 to 10 VDC input will set the high voltage from 0V to its maximum rated output level. The input impedance is approximately 20KΩ.

Meter Outputs

The remote meter outputs generate a DC voltage proportional to the actual test voltage (pins 7 and 9) and leakage current (pins 8 and 9) present at the item under test. These outputs are used to monitor actual test conditions in a computer controlled test system. These outputs are floating relative to the hipot chassis. The input resistance of the measuring device should be at least 100KΩ.

Remote Interface Pinouts
(bold for 10 Volt Option)

SIGNAL OUTPUTS		SIGNAL INPUTS	
PIN	DESCRIPTION	PIN	DESCRIPTION
1	PASS	1	V SET (+)
2	PASS	2	REM RESET
3	FAIL	3	REM TEST
4	FAIL	4	V SET SELECT
5	PROCESS	5	TEST/ RESET COM
6	PROCESS	6	V SET COM
7	VOLTAGE (+)	7	PRGM COM
8	CURRENT (+)	8	PRGM1
9	VOLT/CURRENT COM	9	PRGM2

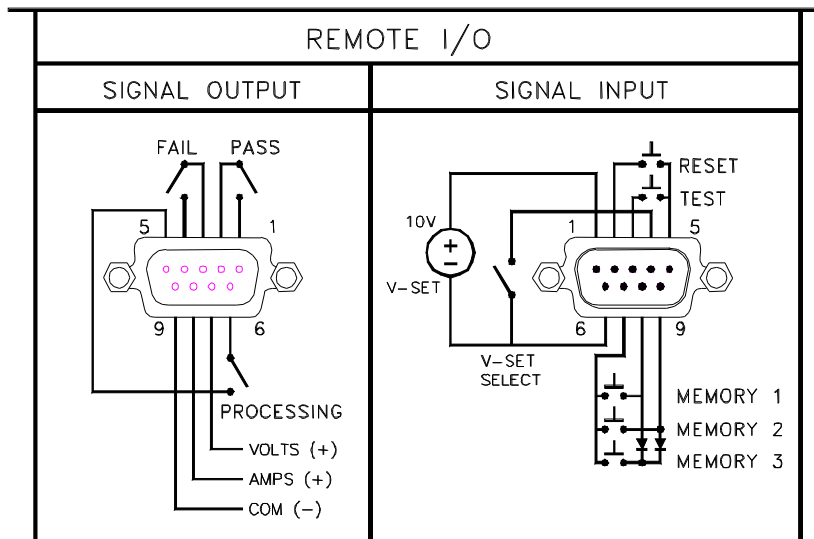

Analog Interface Specifications:

Descriptions	Specifications (Ratios are relative to the display)
V-Set Input	Range: 0 - 10VDC Ratio: 10V = 5 KVAC or 6 KVDC Accuracy: $\pm 2\%$ of Reading
KV Meter Output	Range: 0 - 10VDC Ratio: 10V = 6KV Accuracy: $\pm 2\%$ of Reading
mA Meter Output	Range: 0 - 10VDC Ratio: 10V = 20 mA Accuracy: $\pm 2\%$ of Reading

Note: Specifications subject to change with other installed options. See appropriate options section.

02 5mA Output

The 5mA Output option limits the output current with both hardware and software control. The trip points are adjusted to a maximum of 5mA and the hardware has been modified so the high-speed maximum current shutdown is fixed at 5mA. All other specifications remain the same.

If this option is installed with option 01 10 Volt Analog option. The following specifications apply to the 10Volt Analog option.

10Volt Analog Option with 5 mA Option

Descriptions	Specifications (Ratios are relative to the display)
V-Set Input	Range: 0 - 10VDC Ratio: 10V = 5 KVAC or 6 KVDC Accuracy: $\pm 2\%$ of Reading
KV Meter Output	Range: 0 - 10VDC Ratio: 10V = 6KV Accuracy: $\pm 2\%$ of Reading
mA Meter Output	Range: 0 - 10VDC Ratio: 10V = 5 mA Accuracy: $\pm 2\%$ of Reading

03 Real Current

The Real Current option allows the user to monitor only the real portion of the leakage current and ignore any reactive components due to capacitance in the device under test. It is important to recognize that the total current is the vector sum of the reactive and real current, not the direct addition of the two components. As in a right triangle, the total current is the square root of the sum of the squares of the real and reactive currents.

Since the real component is usually much smaller than the reactive current, a doubling of the real current increases the total current by only a small amount. Unless the two components are separated, a doubling of the real leakage current can go virtually undetected by a total current measurement.

The Associated Research Real Current option allows the operator to view either real or total current. The real current and total current cannot be measured or monitored simultaneously. Independent failure settings for Real and Total current are provided but only one fail detector is active depending on the metering mode of operation. The selection must be made in the menu before the test is run.

To make the selection of Real or Total current press the up arrow key to scroll through the menu. You will see:

Meter =Real	or	Meter =Total
-------------	----	--------------

Press the Enter key to toggle between Real and Total mode. After you have made the selection press the Exit key to return to the run mode. You will see:

Set M_ X.Xs X.XXKV XX.XXmAR	or	Set M_ X.Xs X.XXKV XX.XXmAT
--------------------------------	----	--------------------------------

The letter R or T after the current reading XX.XXmA indicates whether the Hypot PLUS II is in Real or Total current reading mode. All other operation remains the same please refer to the Operation section page 29.

The specifications for the Real Current option are as follows:

Descriptions	Specifications
Voltmeter	Range : 0.00 - 3.00 KVAC Resolution : .01 KV Accuracy : \pm (2 % of reading + 10 V)
Current Meter	Total mode Range : 0.05 - 35.00mA Resolution : .01 mA Accuracy : \pm (2% of reading + .02mA) Real mode Range : 0.05 - 10.00mA Resolution : .01 mA Accuracy : \pm (3% of reading + .05mA)
Failure Settings	Total mode High limit : 0.05 - 35.00 mA, 0.01 mA / step Low limit : 0.00 and 0.05 - 35.00 mA, 0.01 mA / step Accuracy : \pm (2 % of setting + 0.02 mA) Real mode High limit : 0.05 - 10.00 mA, 0.01 mA / step Low limit : 0.00 and 0.05 - 10.00 mA, 0.01 mA / step Accuracy : \pm (2 % of setting + 0.02 mA)

Please allow a ten minute warm up time after power up before operation. A 30 minute warm up time is necessary to guarantee these accuracy's.

If the Real Current option is installed with option 01 10 Volt Analog option. The following specifications apply to the 10 Volt analog option.

10Volt Analog Option with Real Current

Descriptions	Specifications (Ratios are relative to the display)
V-Set Input	Range: 0 - 10VDC Ratio: 10V = 3 KVAC Accuracy: \pm 2% of Reading
KV Meter Output	Range: 0 - 10VDC Ratio: 10V = 3KVAC Accuracy: \pm 2% of Reading
mA Meter Output	Range: 0 - 10VDC Ratio: 10V = 40 mA Total 10V = 10 mA Real Accuracy: \pm (2% of Reading +5mV)

04 8KVAC @ 10mA (AC Only)

The 8KVAC option increases the output voltage of the unit to 8KVAC but reduces the output current to 10mA with both hardware and software control. The trip points are adjusted to a maximum of 10mA and the hardware has been modified so the high speed maximum current shutdown is fixed at 10mA. All other specifications remain the same.

The specifications for the 8KVAC option are as follows:

Descriptions	Specifications
OUTPUT	Rating AC 0 - 8000V, 2V / step, 10mA
FAILURE SETTINGS	AC mode High limit : 0.05 - 10.00 mA, 0.01 mA / step Low limit : 0.00 and 0.05 - 10.00 mA, 0.01 mA / step
METERING	Voltmeter (4 digits) Range : AC 0.00 - 8.00 KV Resolution : 0.01 KV Accuracy : \pm (2 % of reading + 10 V) Ammeter (4 digits) Range : AC 0.05 - 10.00 mA Resolution : 0.01 mA Accuracy : \pm (2 % of reading + 0.02mA)

07 Remote Interlock

Option 07 is a Remote Interlock feature that inverts the present reset logic on the instrument from normally opened (must close contacts to activate the reset) to normally closed (must open contacts to activate the reset). Hardware and software have been reconfigured to provide the interlock connections on pins 2 and 5 of the Remote Interface, Signal Input port. This reset scheme is designed for use with an external safety interlock device that utilizes a "Fail-When-Open" configuration on its output interface. The instrument can still be used without the external reset device as long as the Interlock Connector 38037 (provided with unit) is plugged into the Remote Interface, Signal Input port. If there is nothing connected to the Remote Interface, Signal Input port to provide a connection to the interlock (reset), then the instrument will not function. Please refer to page 40 for further information about the remote interface.

08 7 Remote Memories Select

The 7 Remote Memories Select option increases the number of memory programs that may be accessed through the remote control connector from 3, to 7. This gives the user the capability to quickly change parameters and initiate a test remotely. The HypotPLUS II basically operates in a PLC mode by responding to simple switch or relay contacts closures, the built in memory programs of the instrument are used to accomplish this. Seven internal memory programs can be accessed by connecting terminals 3,7,8, and 9 in different combinations. The binary truth table shows the different combinations of momentary switch (relay) closures, and which memory programs that will be selected as the result. It may be necessary to "OR" the momentary switches (relay contacts) to prevent incorrect program selection due to timing errors.

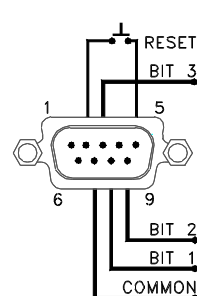
7 MEMORIES SELECT TRUTH TABLE				REMOTE I/O
BIT 3	BIT 2	BIT 1	MEMORY PROGRAM #	SIGNAL INPUT
0	0	1	1	
0	1	0	2	
0	1	1	3	
1	0	0	4	
1	0	1	5	
1	1	0	6	
1	1	1	7	
1= Momentary Contact closure between BIT and COMMON				
0= No Contact closure between BIT and COMMON				

ACTIVATING MEMORY PROGRAM FUNCTIONS THROUGH THE REMOTE CONNECTOR, SELECTS THE PROGRAM, AND STARTS THE TEST THAT IS PREPROGRAMMED INTO THAT MEMORY.

NOTE: The remote "Test" switch **CAN NOT** be used (but is no longer necessary) if this option has been installed. The remote "Reset" switch **CAN** still be used in this configuration.

WARNING DO NOT CONNECT VOLTAGE OR CURRENT TO THE SIGNAL INPUTS, THIS COULD RESULT IN DAMAGE TO THE CONTROL CIRCUITRY.

This page is intentionally left blank.

SECTION 2
SERVICE MANUAL

CALIBRATION PROCEDURES

This instrument has been fully calibrated at the factory in accordance to our published specifications. It has been calibrated with standards traceable to NIST. You will find in this manual a copy of the "Certificate of Calibration". It is recommended that you have this instrument recalibrated and a safety check done at least once per year. AR recommends you use "Calibration Standards" that are NIST traceable, or traceable to agencies recognized by NIST to keep this instrument within published specifications. End user metrology standards or practices may vary. These metrology standards determine the measurement uncertainty ratio of the calibration standards being used. Calibration adjustments can only be made in the Calibration mode, calibration checks can only be made in the Test mode of operation.

Calibration Equipment Required:

The following equipment will be needed to properly calibrate your instrument.

- 1). Digital Multimeter with the minimum ranges;
ac voltage: 5,000 volts
ac current: 25mA range.
- 2). 500K Ω /50Watt resistor

CALIBRATION PROCEDURE:

To enter the calibration mode the instrument must be in the OFF position. Press and hold the "0" key, then turn on the Input Power Switch. The display will show:

Calibration Mode 2:KV 3:mA 7:Lock

Press "2" for kilovolts calibration, "3" for milliamps and "7" for the password and lock mode settings.

1. Calibration of Voltage

Equipment needed: STANDARD AC VOLTMETER capable of measuring 5000VAC.

Please connect a standard ac voltmeter with 5000V minimum full scale range to the high voltage and return connectors. Then press the "2" key on the front panel. The instrument will provide around 5000VAC on the output connectors and the display will show:

Voltage = __ V

Please use the numerical keys to enter the reading off the ac voltmeter into the instrument. Then press the “Enter” key to store the voltage setting. If an incorrect value is entered, press the “EXIT” key. Then the correct value may be re-entered.

2. Calibration of Current

Equipment needed: STANDARD AC MILLIAMMETER with a range of 25mA and a fixed Resistor 500K Ohms, 50 watts.

Please connect a 500K Ω resistor in series with the standard ac milliammeter and connect these across the output leads of the instrument. Press the “3” key. The instrument will provide around 5000VAC on the output and the display will show:

Current = __ mA

Please use the numerical keys to enter the reading of the standard ac milliammeter into the instrument. Then press the “Enter” key to store the current setting. If an incorrect value is entered, press the “EXIT” key. The correct value may be re-entered.

3. Setup of the Password and Lock Function

Please refer to the setup procedures section of this manual.

Replacement Parts List HYPOTPLUS II

Model 5500DT 5560DT

Rev. F 12/07/99 ECO 4742

Part Number	Qty.	Reference Designator	Description
37547	1	AMP-100	Main Power Amplifier Board
37548	1	CGC-01	Ground Continuity Check Board
37570	1	CHV-03-AC	High Voltage Control Board (5500DT only)
37549	1	CHV-03	High Voltage Control Board (5560DT only)
37550	1	CKB-01	Key Board Assembly
37515	1	CSW-01	Input Protection Board
37546	1	CW7020	Main Control Board
37571	1	-	Earth Connector
35999	4	-	Black Banana Jacks
37478	2	-	High Voltage Connector
38101	1	-	Feet Kit w/o Rubber Inserts
38102	4	-	Rubber Insert
37857	1	-	Fuse 5A 250V Slo-Blo 5x20mm
37781	1	-	Fuse Holder 5x20mm
37554	1	-	LCD Display 16 x 2 Characters
37555	1	-	Power Switch 2P 10A/250V
37556	1	-	Test Switch, Green
37557	1	-	Reset Switch, Red
37886	1	T2	Output High Voltage Transformer
37782	1	T1	Input Transformer Toroid
37561	1	-	RS-232 Cable, 20 cm/RS-232 Female One End and Ribbon Female on Other End
37562	1	-	RS-232 Cable, 23 cm/RS-232 Male One End and Ribbon Female on Other End
37563	2	-	Handle for Mounting Bracket 2U
37564	2	-	19" Mounting Bracket
33189	1	-	Input Power Cable 10A/7Ft.
04040A-08	1	-	High Voltage Output cable
02100A-13	1	-	Return cable
37487	7	Q1-Q7	Power Transistors D1148
37783	1	RY1	Relay Gunther 3390-1290-246
37784	1	RY2	Relay Gunther 3392-1290-246
37566	2	R22	Resistor Fixed 2K, 5W, 5%
37567	1	IC25	12 Bit D/A Converter 7237
37697	1	IC31	IC 89C52 Microcontroller 8 Bit
37569	1	IC21	8 Bit D/A Converter DAC 1408

SCHEMATIC INDEX

Drawing Number	Description	Pages
S05500DTBD	Block Diagram	2
S37546	Main Control Board	5
S37570	HV Control Board AC only (5500DT)	1
S37549	HV Control Board AC/DC (5560DT)	1
S37547	Main Power Amplifier Board	1
S37548	Ground Continuity Check Board	1
S37550	Keypad Board	1
S37515	Input Protection Board	1
S38220	ROM Conversion Board	1

Alternate or Additional Schematics						
(note: These schematics apply only to HypotPLUS II with installed options. Some optional hardware changes are referred to on standard schematics)						
Drawing Number	Description	Options				Pages
		01	03	0102	0103	
S05500DT-25	10 Volt Analog Option	x		x	x	2
S37546-01	10 Volt Main Control (replace S37546)	x		x		5
S05500DT-37	Real Current		x		x	1
S37546-03	Real Current Main Control (replace S37546)		x			5
S37546-0103	Real Current/ 10 Volt Main Control (replace S37546)				x	5