

OPERATION AND SERVICE MANUAL

HYAMP<sup>®</sup> jr.

MODEL 3030D GROUND BOND TESTER

SERIAL NUMBER

|  |  |  |  |  |  |  |
|--|--|--|--|--|--|--|
|  |  |  |  |  |  |  |
|--|--|--|--|--|--|--|

***Model 3030D***

*Item 37952*

*Ver 1.05*

© Associated Research, Inc., 2000  
13860 West Laurel Drive  
Lake Forest, Illinois, 60045-4546  
U.S.A.

Printed Nov 17, 2000

## 5 YEAR WARRANTY POLICY

Associated Research, Inc., certifies that the instrument listed in this manual meets or exceeds published manufacturing specifications. This instrument was calibrated using standards that are traceable to the National Institute of Standards and Technology (NIST).

Your new instrument is warranted to be free from defects in workmanship and material for a period of (1) year from date of shipment. Options and accessories that are external to the instrument are warranted for a period of (90) days from the date of shipment. You must return the "Owners Registration Card" provided within (15) days from receipt of your instrument.

AR recommends that your instrument be calibrated on a twelve-month cycle. Instruments purchased and used in North America only, may have their warranty extended in one-year increments to a maximum of **(5) years** provided they are returned to AR at least **annually** for calibration and inspection. The annual calibration and inspection must be performed annually each and every year following receipt of instrument. Any instrument not calibrated and inspected annually will not be eligible for extended warranty status. This extended warranty is non-transferable and is offered only to the original purchaser.

A return material authorization (RMA) must be obtained from AR before returning this instrument for warranty service. Please contact our Customer Support Center at 1-800-858-TEST (8378) to obtain an RMA number. It is important that the instrument is packed in its original container for safe transport. If the original container is not available please contact our customer support center for proper instructions on packaging. Damages sustained as a result of improper packaging will not be honored. Transportation costs for the return of an instrument for warranty service must be prepaid by the customer. AR will assume the return freight costs when returning the instrument to the customer during the first year of ownership. All freight charges after the first year are the customer's responsibility. The return method will be at the discretion of Associated Research.

Except as provided herein, Associated Research makes no warranties to the purchaser of this instrument and all other warranties, express or implied (including, without limitation, merchantability or fitness for a particular purpose) are hereby excluded, disclaimed and waived.

Any non-authorized modifications, tampering or physical damage will void your warranty. Elimination of any connections in the earth grounding system or bypassing any safety systems will void this warranty. This warranty does not cover batteries or accessories not of Associated Research manufacture. Parts used must be parts that are recommended by AR as an acceptable specified part. Use of non-authorized parts in the repair of this instrument will void the warranty.

# TABLE OF CONTENTS

|  |           |
|--|-----------|
| <b>SECTION I OPERATORS MANUAL.....</b> | <b>1</b>  |
| SAFETY.....                            | 2         |
| INTRODUCTION.....                      | 5         |
| SPECIFICATIONS.....                    | 8         |
| CONTROLS.....                          | 12        |
| INSTALLATION.....                      | 15        |
| QUICK START.....                       | 18        |
| OPERATION.....                         | 22        |
| OPTIONS.....                           | 32        |
| <b>SECTION II SERVICE MANUAL.....</b>  | <b>35</b> |
| CALIBRATION.....                       | 36        |
| PARTS LIST.....                        | 38        |
| SCHEMATICS.....                        | 39        |

**SECTION 1**  
**OPERATORS MANUAL**

## **SAFETY PRECAUTIONS**

### **GENERAL:**

This product and its related documentation must be reviewed for familiarization with safety markings and instructions before operation.

This product is a Safety Class I instrument (provided with a protective earth terminal).

Before applying power verify that the instrument is set to the correct line voltage (115 or 230) and the correct fuse is installed.



INSTRUCTION MANUAL SYMBOL. PLEASE REFER TO THE INSTRUCTION MANUAL FOR SPECIFIC WARNING OR CAUTION INFORMATION TO AVOID PERSONAL INJURY OR DAMAGE TO THE PRODUCT.



INDICATES HAZARDOUS VOLTAGES MAY BE PRESENT.



CHASSIS GROUND SYMBOL.



CALLS ATTENTION TO A PROCEDURE, PRACTICE, OR CONDITION, THAT COULD POSSIBLY CAUSE BODILY INJURY OR DEATH.



CALLS ATTENTION TO A PROCEDURE, PRACTICE, OR CONDITION THAT COULD POSSIBLY CAUSE DAMAGE TO EQUIPMENT OR PERMANENT LOSS OF DATA.

## SERVICE AND MAINTENANCE

### User Service

To prevent electric shock do not remove the instrument cover. There are no user serviceable parts inside. Routine maintenance or cleaning of internal parts is not necessary. Any external cleaning should be done with a clean dry or slightly damp cloth. Avoid the use of cleaning agents or chemicals to prevent any foreign liquid from entering the cabinet through ventilation holes or damaging controls and switches, also some chemicals may damage plastic parts or lettering. Schematics, when provided, are for reference only. Any replacement cables and high voltage components should be acquired directly from Associated Research, Inc. Refer servicing to an Associated Research, Inc. authorized service center.

ASSOCIATED RESEARCH, INC.  
13860 WEST LAUREL DRIVE  
LAKE FOREST, IL 60045-4546 U.S.A.

PHONE: 1 (847) 367-4077

1 (800) 858-TEST (8378)

FAX: 1 (847) 367-4080

E-MAIL : info@asresearch.com

www.asresearch.com

### Service Interval

The instrument and its power cord, test leads, and accessories must be returned at least once a year to an Associated Research authorized service center for calibration and inspection of safety related components. Associated Research will not be held liable for injuries suffered if the instrument is not returned for its annual safety check and maintained properly.

### User Modifications

Unauthorized user modifications will void your warranty. Associated Research will not be responsible for any injuries sustained due to unauthorized equipment modifications or use of parts not specified by Associated Research. Instruments returned to Associated Research with unsafe modifications will be returned to their original operating condition at your expense.

## TEST STATION

### Location

Select an area away from the main stream of activity which employees do not walk through in performing their normal duties. If this is not practical because of production line flow, then the area should be roped off and marked for **TESTING**. No employees other than the test operators should be allowed inside.

If benches are placed back-to-back, be especially careful about the use of the bench opposite the test station. Signs should be posted: "**DANGER - TEST IN PROGRESS - UNAUTHORIZED PERSONNEL KEEP AWAY.**"

### Power

Ground Bond Test Equipment must be connected to a good ground. Be certain that the power wiring to the test bench is properly polarized and that the proper low resistance bonding to ground is in place.

Power to the test station should be arranged so that it can be shut off by one prominently marked switch located at the entrance to the test area. In the event of an emergency, anyone can cut off the power before entering the test area to offer assistance.

### Work Area

Perform the tests on a nonconducting table or workbench, if possible.

There should not be any metal in the work area between the operator and the location where products being tested will be positioned.

Position the tester so the operator does not have to reach over the product under test to activate or adjust the tester. If the product or component being tested is small, it may be possible to construct guards or an enclosure, made of a non-conducting material such as clear acrylic. The item being tested is then within the guards or enclosure during the test, and may be fitted with switches so that the tester will not operate unless the guards are in place or the enclosure closed.

Keep the area clean and uncluttered. All test equipment and test leads not absolutely necessary for the test should be removed from the test bench and put away. It should be clear to both the operator and to any observers what product is being tested, and which products are waiting to be tested or have already been tested.

Do not perform Ground Bond Tests in a combustible atmosphere or in any area where combustible materials are present.

## **TEST OPERATOR**

### Qualifications

The operator should understand the electrical fundamentals of voltage, current, and resistance.

### Safety Procedures

Operators should be thoroughly trained to follow these and all other applicable safety rules and procedures before they begin a test. Defeating any safety system should be treated as a serious offense and should result in severe penalties, such as removal from the Ground Bond Testing job. Allowing unauthorized personnel in the area during a test should also be dealt with as a serious offense.

### Dress

Operators should not wear jewelry that could accidentally complete a circuit.

### Medical Restrictions

Personnel with heart ailments or devices such as pacemakers should not operate this instrument.

## GLOSSARY OF TERMS

(As used in this manual)

**Alternating Current, AC:** Current that reverses direction on a regular basis, commonly in the U.S.A. 60 times per second, in other countries 50 times per second.

**Conductive:** Having a volume resistivity of no more than  $10^3$  ohm-cm or a surface resistivity of no more than  $10^5$  ohms per square.

**Conductor:** A solid or liquid material which has the ability to let current pass through it, and which has a volume resistivity of no more than  $10^3$  ohm-cm.

**Current:** The movement of electrons through a conductor. Current is measured in amperes, milliamperes, microamperes, nanoamperes, or picoamperes. Symbol = **I**

**Dielectric:** An insulating material that is positioned between two conductive materials in such a way that a charge or voltage may appear across the two conductive materials.

**Direct Current, DC:** Current that flows in one direction only. The source of direct current is said to be polarized and has one terminal that is always at a higher potential than the other.

**Hipot Tester:** Common term for dielectric-withstand test equipment.

**Hypot®:** Registered trademark of Associated Research, Inc., for its dielectric-withstand test equipment.

**HYAMP®:** Registered trademark of Associated Research for its Ground Bond test equipment.

**Insulation:** Gas, liquid or solid material which has a volume resistivity of at least  $10^{12}$  ohm-cm and is used for the purpose of resisting current flow between conductors.

**Resistance:** That property of a substance that impedes current and results in the dissipation of power in the form of heat. The practical unit of resistance is the *ohm*. Symbol = **R**

**Trip Point:** The minimum resistance required causing an indication of unacceptable performance during a ground bond test.

**Voltage:** Electrical pressure, the force which causes current through an electrical conductor.  
Symbol = **V**



## INTRODUCTION

### **The importance of testing... User safety**

In an era of soaring liability costs, original manufacturers of electrical and electronic products must make sure every item is as safe as possible. All products must be designed and built to prevent electric shock, even when users abuse the equipment or by-pass built in safety features.

To meet recognized safety standards, one common test is the "dielectric voltage-withstand test". Safety agencies which require compliance safety testing at both the initial product design stage and for routine production line testing include: Underwriters Laboratories, Inc. (UL), the Canadian Standards Association (CSA), the International Electrotechnical Commission (IEC), the British Standards Institution (BSI), the Association of German Electrical Engineers (VDE), the Japanese Standards Association (JSI). These same agencies may also require that an insulation resistance test and high current ground bond test be performed.

### **The Dielectric Withstand (Hipot) Test...**

The principle behind a dielectric voltage - withstand test is simple. If a product will function when exposed to extremely adverse conditions, it can be assumed that the product will function in normal operating circumstances.

The most common applications of the dielectric-withstand test are:

- Design (performance) Testing.... determining design adequacy to meet service conditions.
- Production Line Testing.... detecting defects in material or workmanship during processing.
- Acceptance Testing.... proving minimum insulation requirements of purchased parts.
- Repair Service Testing.... determine reliability and safety of equipment repairs.

The specific technique varies with each product, but basically, during a dielectric voltage withstand test, an electrical device is exposed to a voltage significantly higher than it normally encounters. The high voltage is continued for a given period of time.

If, during the time the component is tested, stray current flow remains within specified limits, the device is assumed to be safe under normal conditions. The basic product design and use of the insulating material will protect the user against electrical shock.

The equipment used for this test, a dielectric-withstand tester, is often called a "hipot" (for high potential tester). The "rule of thumb" for testing is to subject the product to twice its normal operating voltage, plus 1,000 volts.

However, specific products may be tested at much higher voltages than 2X operating voltages + 1,000 volts. For example, a product designed to operate in the range between 100 to 240 volts can be tested between 1,000 to 4,000 volts or higher. Most "double insulated" products are tested at voltages much higher than the "rule of thumb".

Testing during development and prototype stages is more stringent than production run tests because the basic design of the product is being evaluated. Design tests usually are performed on only a few samples of the product. Production tests are performed on each and every item as it comes off the production line.

The hipot tester must also maintain an output voltage between 100% and 120% of specification. The output voltage of the hipot must have a sinusoidal waveform with a frequency between 40 to 70 Hz and has a peak waveform value that is not less than 1.3 and not more than 1.5 times the root-mean-square value.

#### **Why Perform a Ground Bond Test .....**

Ground bond testing is done to insure that a low resistance path exists between the safety ground pin of a three-wire line cord and exposed metal of the item under test. If a live wire inside the item under test came loose and contacted the chassis, the fault current would flow through the low resistance safety ground, and protect the user.

The need for high current bonding (i.e. 10A or 30A) as apposed to low current go-no go type testers, results from the nature of line voltage breakers' high current characteristics. Safety Grounding circuits must withstand the line voltage breaker' current rating in order to maintain a safe voltage potentials on the chassis of the faulty device. Verifying the integrity of the grounding circuit at high currents insures that the line breaker will open before the grounding circuit wires fail. This insures that the power will be de-energized at the device while maintaining safe voltage levels on the chassis.

**IF YOU SHOULD HAVE ANY QUESTIONS RELATING TO THE OPERATION  
OF YOUR INSTRUMENT CALL 1-800-858-TEST (8378) IN THE U.S.A.**

## Model 3030D Functional Specifications

### GROUND BOND TEST MODE

Unless otherwise stated, accuracies are relative to a laboratory standard measurement.

| Descriptions       | Specifications  |
|--------------------|---|
| INPUT VOLTAGE      | 115 / 230V selectable, $\pm 15\%$ variation<br>47 - 63 Hz   |
| FUSE               | 6.3A slow blow 250VAC   |
| OUTPUT             | Current: AC 3 - 30Amps, 0.1 Amp / step<br>Regulation: $\pm(2\%$ of Setting + 0.02 A)<br>Voltage: AC 6 Volts fixed   |
| OUTPUT FREQUENCY   | 50 / 60 Hz selectable   |
| DWELL TIME SETTING | 0 and 0.5 - 999.9 seconds, 0.1 second / step<br>0 for continuous running<br>Accuracy: $\pm(0.1\%$ of Setting + 0.05 seconds)  |
| FAILURE SETTINGS   | High limit: 0 - 120m $\Omega$ for 3 - 30 Amps, 1m $\Omega$ / step<br>0 - 510m $\Omega$ for 3 - 10 Amps, 1m $\Omega$ / step<br>Accuracy: $\pm(2\%$ of setting + 2m $\Omega$ )  |
| MILLIOHM OFFSET    | Max. Offset Capability: 100m $\Omega$ , 1m $\Omega$ / step<br>Accuracy: $\pm(2\%$ of setting + 2m $\Omega$ )  |
| METERING           | Ammeter (3 digits)<br>Range: 0 - 30 Amps<br>Resolution: 0.1 Amp / step<br>Accuracy: $\pm(3\%$ of Reading + 0.03A)<br><br>Ohmmeter (3 digits)<br>Range: 0 - 510m $\Omega$<br>Resolution: 1 m $\Omega$ / step<br>Accuracy: $\pm(2\%$ of Reading + 2m $\Omega$ )<br><br>Timer (4 digits)<br>Range: 0 - 999.9 seconds<br>Resolution: 0.1 seconds / step<br>Accuracy: $\pm(0.1\%$ of Reading + 0.05 seconds) |

|                                  |   |
|----------------------------------|---|
| REMOTE CONTROL AND SIGNAL OUTPUT | The following input and output signals are provide through two 9 pin D type connectors;<br>1. Remote control: Test, Reset and Withstand Processing<br>2. Outputs: Pass, Fail, Test in Process, Start Out, and Reset Out                                 |
| SECURITY                         | Key Lock capability to avoid unauthorized access to <u>all</u> test parameters. Memory Lock capability to avoid unauthorized access to Memory locations.  |
| LINE CORD                        | Detachable 7 ft. (2.13m) power cable terminated in a three prong grounding plug.  |
| TERMINATIONS                     | 5ft. (1.52m) high current and return leads with clips.  |
| MECHANICAL                       | Bench style with tilt up front feet<br>Dimensions:<br>(w x h x d) 11 x 3.5 x 14.56 in. (280 x 89 x 370mm)<br>Weight:<br>20 lbs. (9 kg)  |
| ENVIRONMENTAL                    | Operating Temperature: 32° - 113°F (0° - 45°C)<br>Relative Humidity: 0 to 95%   |
| CALIBRATION                      | Traceable to National Institute of Standards and Technology (NIST). Calibration controlled by software. Adjustments are made through front panel keypad in a restricted access calibration mode. Calibration information stored in non-volatile memory. |
| PROGRAM MEMORY                   | 5 sets  |

**KEY FEATURES & BENEFITS OF HYAMP jr.**

1. All parameters for the setups can be adjusted through a simple menu driven program by using front panel keys.  
*The easy to follow setup screens ensure that the operator correctly sets up all test parameters.*
2. Tamper proof front panel controls.  
*This makes it possible to limit user access to the setup screens.*
3. Milliohm offset capability.  
*The milliohm offset function allows the use of longer test leads and test fixtures without compromising the test results.*
4. Storage of up to 5 different test programs.  
*A real benefit for manufacturers that test different products. This makes it possible to store all the various test parameters required and quickly recall them for each of the different products that needs to be tested.*
5. Versatile PLC control.  
*Interconnection of the HYAMP jr. and the Hypot II makes these two instruments a true semi-automated test system. The test system can be configured to test Ground Bond first and then advance to the Dielectric Withstand test and Insulation Resistance tests.*
6. Line and load regulation.  
*This system maintains the output voltage to within 1% from no load to full load and over the line voltage range to ensure that test results remain consistent and within safety agency requirements.*
7. User selectable output voltage frequencies of 50 or 60 hertz.  
*HYAMP jr. was designed for the global market. This feature makes it simple for the user to select the output frequency in the Ground Bond mode so that products can be tested at the same frequency they will be used at.*
8. Adjustable output current and milliohm trip ranges.  
*This capability makes the HYAMP jr. versatile enough to meet all safety agency specifications for ground bond test requirements.*
9. Front panel LCD displays test parameters and results.  
*A front panel LCD allows the operator to monitor the test. The display holds the results after a test item failure so that the operator can easily review the test results.*
10. PLC remote inputs and outputs.  
*The standard 9 pin interfaces provide outputs for Pass, Fail, and Test in Process, Start Out and Reset Out. Inputs include Test, Reset, and Withstand Processing.*

11. Test indicator.

*An LED located directly over the high current terminal clearly indicates when high current is active to provide maximum operator safety.*

12. Withstand processing indicator.

*The front panel display indicates when the high voltage from the Hypot II is being applied to the item under test for greater operator safety.*

13. Software calibration control.

*HYAMP jr. is calibrated through the front panel keypad. All calibration information is stored in non-volatile memory. This allows HYAMP jr. to be completely calibrated without removing any covers and exposing the technician to hazardous voltages.*

FRONT PANEL CONTROLS

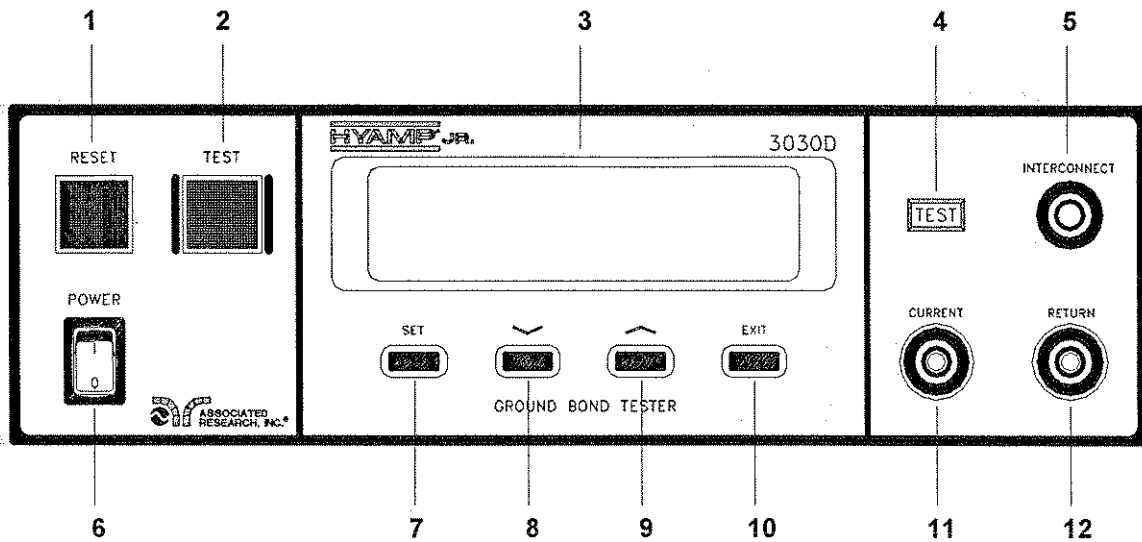

1. **RESET SWITCH:** This is a momentary contact switch. To reset the system for the next test, press and release the red Reset switch (1). This switch may also be used to abort a Test in Progress.
2. **TEST SWITCH:** This is a momentary contact switch. Press the green switch to turn on the high current output when in the test mode.
3. **LCD DISPLAY:** The Liquid Crystal Display is the main readout for the operator and programmer of the test settings and test results.
4. **TEST LED INDICATOR:** This red LED lights to indicate to the operator that a test is in process.
5. **INTERCONNECT JACK:** For the connection of the return lead from the hipot tester used when performing both Hipot and Ground Bond tests on the same test item.
6. **POWER SWITCH:** Rocker-style switch with international ON (I) and OFF (O) markings.
7. **SET KEY:** Use this key to advance forward through the setup menus.
8. **DOWN ARROW (∨):** Use this key to decrement numeric values in the setup mode. This key may also be used to toggle ON/OFF functions.
9. **UP ARROW (∧):** Use this key to increment numeric values in the setup mode. This key may also be used to toggle ON/OFF functions.

FRONT PANEL CONTROLS

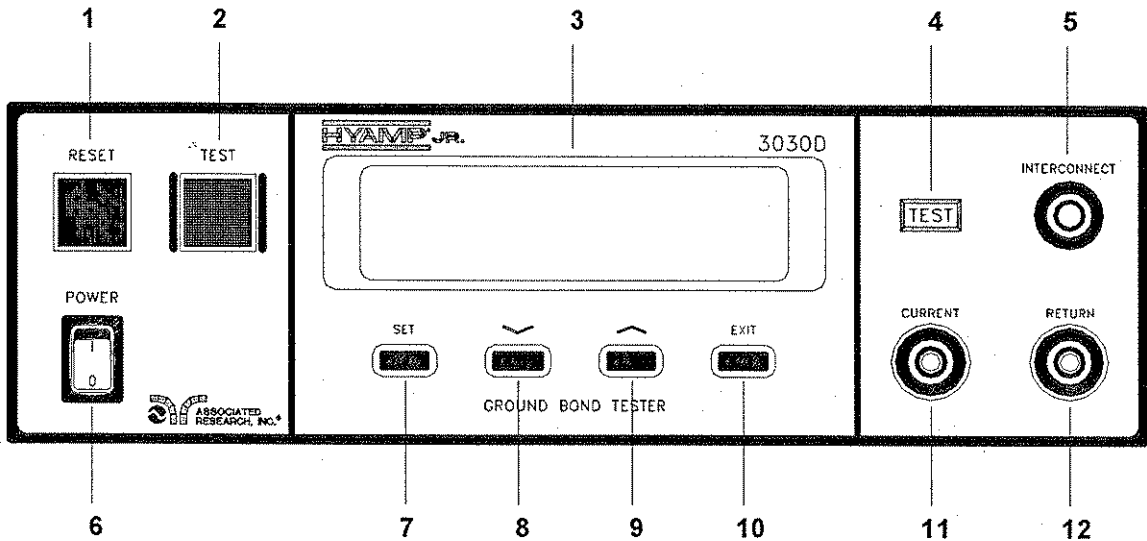

**10. EXIT KEY:** Use this key when you desire to enter the **Run Mode** to initiate a test. This key may also be used to save settings into memory.

**11. CURRENT OUTPUT JACK:** For the connection of the detachable 5-foot (1.52 m) red high current test lead. This jack is always used when performing a Ground Bond test.

**12. RETURN OUTPUT JACK:** For the connection of the detachable 5-foot (1.52 m) black return test lead. This jack is always used when performing a test.



REAR PANEL CONTROLS

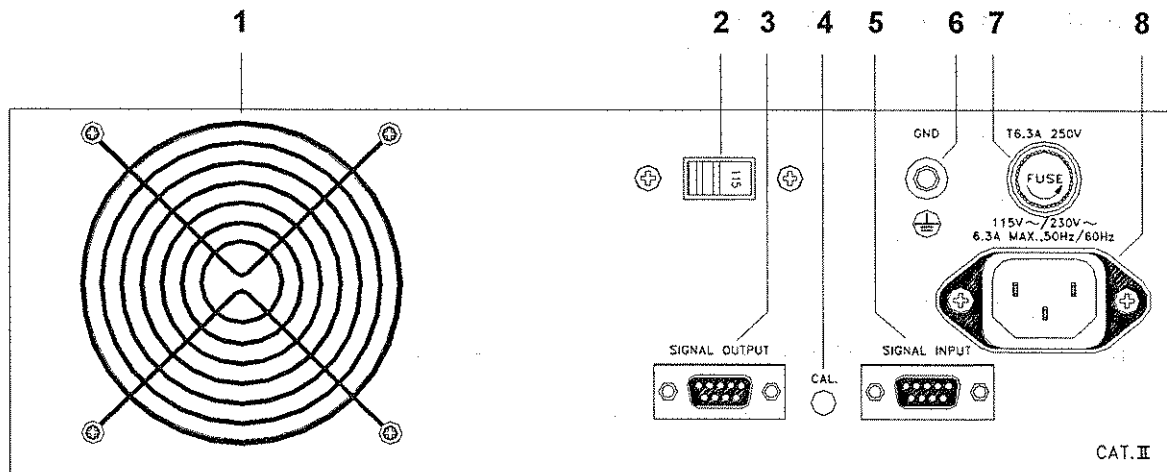

1. **THERMAL FAN:** Runs continuously to cool the instrument.
2. **INPUT POWER SWITCH:** Line voltage selection is set by the position of the switch. In the left position it is set for 115-volt operation, in the right position it is set for 230-volt operation.
3. **REMOTE OUTPUT:** 9 pin D subminiature female connector for monitoring PASS, FAIL, and PROCESSING output relay signals, as well as remote START and RESET outputs.
4. **CALIBRATION ENABLE:** This recessed switch when depressed allows access to the calibration control program.
5. **REMOTE INPUT:** 9 pin D subminiature male connector for remote control of test and reset functions as well as withstand processing input.
6. **CHASSIS GROUND (EARTH) TERMINAL:** This safety terminal should be connected to a good earth ground before operation.
7. **FUSE RECEPTACLE:** To change the fuse unplug the power (mains) cord and unscrew the fuse cap counter clockwise to remove the fuse.
8. **INPUT POWER RECEPTACLE:** Standard IEC 320 connector for connection to a standard NEMA style line power (mains) cord.

---

## INSTALLATION

### Introduction

This section contains information for the unpacking, inspection, preparation for use and storage of your Associated Research, Inc., product.

### Unpacking and Inspection

Your instrument was shipped in a custom foam insulated container that complies with ASTM D4169-92a Assurance Level II Distribution Cycle 13 Performance Test Sequence.

If the shipping carton is damaged, inspect the contents for visible damage such as dents, scratches or broken meters. If the instrument is damaged, notify the carrier and the Associated Research customer support department immediately. Please save the shipping carton and packing material for the carriers inspection. Our customer support department will assist you in the repair or replacement of your instrument. Please do not return your product without first notifying us and receiving an RGA (return goods authorization) number.

### Preparation for Use

#### Power Requirements and Line Voltage Selection

This instrument requires a power source either 115 volts AC  $\pm$  15%, 47-63 Hz single phase or 230 volts AC  $\pm$  15%, 47-63 Hz single phase. Please check the rear panel to be sure the proper switch setting is selected for your line voltage requirements before turning your instrument on. In addition, please be sure the correct fuse is selected and installed while the instrument is in the off position.

|                |
|----------------|
| <b>CAUTION</b> |
|----------------|

Do not switch the line voltage selector switch located on the rear panel while the instrument is on or operating. This may cause internal damage and represents a safety risk to the operator.

#### NOTE

For operation at 115 Volts AC and 230 Volts AC use a 6.3A 250VAC slow blow fuse.

**Power Cable**

**WARNING** BEFORE CONNECTING POWER TO THIS INSTRUMENT, THE PROTECTIVE GROUND (EARTH) TERMINALS OF THIS INSTRUMENT MUST BE CONNECTED TO THE PROTECTIVE CONDUCTOR OF THE LINE (MAINS) POWER CORD. THE MAIN PLUG SHALL ONLY BE INSERTED IN A SOCKET OUTLET (RECEPTACLE) PROVIDED WITH A PROTECTIVE GROUND (EARTH) CONTACT. THIS PROTECTIVE GROUND (EARTH) MUST NOT BE DEFEATED BY THE USE OF AN EXTENSION CORD (POWER CABLE) WITHOUT A PROTECTIVE CONDUCTOR (GROUNDING).

This instrument is shipped with a three-wire power cable. When this cable is connected to an appropriate AC power source, this cable connects the chassis to earth ground. The type of power cable shipped with each instrument depends on the country of destination.

**Test Leads**

The test leads provided are designed specifically for use with this instrument. The red High Current lead will mate with the red Current jack. The black Return lead will connect to the black Return jack.

The test lead ratings are as follows:

| Description       | Part Number | Rating     |
|-------------------|-------------|------------|
| Return lead       | 37953       | 30 A, 600V |
| High Current lead | 37954       | 30 A, 600V |

**Operating Environment**

This instrument may be operated in temperatures from 32° - 113° F (0° - 45° C).

Relative humidity of 0 to 95%.

Altitude up to 15,000 feet (4,600 meters).

Ventilation: When choosing a bench location, or in rack mount applications, insure that there is at least 6 inches (15 cm) of space from the rear panel to any wall or obstruction behind the unit.

**STORAGE AND SHIPMENT**
**Environment**

This instrument may be stored or shipped in environments with the following limits:

Temperature..... -40° to +75°C

Altitude..... 7,620 meters (25,000 feet)

The instrument should also be protected against temperature extremes, which may cause condensation within the instrument.

**Packaging**

Original Packaging: Please retain all original packaging materials if you do not have an alternate method of repackaging. If you are returning your instrument to us for servicing

please repackage the instrument in its original container or use an alternate packaging solution. Please do not reuse the original packing material if there appears to be damage or missing packing material. Contact our customer support department (1-800-858-8378) for an RMA (return materials authorization) number. Please enclose the instrument with all options, accessories and test leads. Indicate the nature of the problem or type of service needed. Also, please mark the container "FRAGILE" to insure proper handling. Upon receipt your instrument will be issued an AR service number. Please refer to this number in all correspondence.

**Other Packaging:** If you do not have the original packaging materials please follow these guidelines:

- 1). Wrap the instrument in a bubble pack or similar foam. Enclose the same information as above.
- 2). Use a strong double-wall container that is made for shipping instrumentation. 350-lb. test material is adequate.
- 3). Use a layer of shock-absorbing material 70 to 100 mm (3 to 4 inch) thick around all sides of the instrument. Protect the control panel with cardboard.
- 4). Seal the container securely.
- 5). Mark the container "FRAGILE" to insure proper handling.
- 6). Please ship model 3030D via Federal Express or UPS air.
- 7). Please reference in all your correspondence your AR service number.

### **Field Installation of Options**

There are no field installable options on the model 3030D.

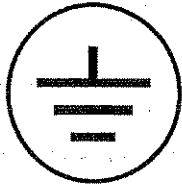
**QUICK START**

This quick start guide assumes the operator has some familiarity with automated Ground Bond testing and desires to use the **default** settings on the instrument. The default settings shown will remain in memory unless you choose to override them with your own test program. The instrument default settings are as follows:

**DEFAULTS**

- **Memory Position:** 1
- **Input Voltage:** 115 volts AC (rear panel switch selectable)
- **Current Output:** 25.00 Amps
- **Resistance Trip (High):** 100m $\Omega$
- **Dwell Timer:** 1 second
- **Frequency:** 60Hz
- **Offset:** 20m $\Omega$
- **Lock:** Key Unlock

a). Unpack this instrument from its special shipping container. Be sure to save all packaging materials in case you need to return it to the factory for service.

**WARNING**

b). Locate a suitable testing area and be sure you have read all safety instructions for the operation of the instrument and suggestions on the test area set-up in the SAFETY section of this manual. Locate a three prong grounded outlet. Be sure the outlet has been tested for proper wiring before connecting the instrument to it.

**CAUTION**

c). Check to be sure that the correct input line voltage has been selected on the rear panel, either 115 volts AC or 230 volts AC. Connect the power-input plug into its socket on the rear panel of the instrument. Connect the male end of the plug to the outlet receptacle.

Please be sure that the safety ground on the power line cord is not defeated and that you are connecting to a grounded power source.

d). Turn on the POWER switch located on the lower left hand side of the front panel. Upon powering the instrument up a POWER ON SELF TEST (POST) will automatically be performed. This test will check for the condition of the ram chips, led indicators, PCB's and other critical components. In addition, you will see the Associated Research name and Model Number briefly appear on the LCD readout and then clear itself.

|                                   |
|-----------------------------------|
| ARI HYAMP JR.<br>3030D      VERXX |
|-----------------------------------|

You should then see the default parameters on the LCD meter as follows:

|        |    |       |
|--------|----|-------|
| Set    | M1 | 1.0s  |
| 25.00A |    | 100mΩ |

These abbreviated parameters stand for the following:

**Set:** This is the parameter settings review screen.  
**M1:** The instrument is using the default set ups contained in memory 1.  
**1.0s:** The dwell timer is set to test duration of 1 second.  
**25.00A:** The test current is set to 25.00 Amps.  
**100mΩ:** The high resistance trip point is set to 100 milliohms.

If you wish to not use any one of these parameters you must overwrite the memory 1 position or change your parameters and save them in a different memory such as memory position 2.

e). If the instrument defaults are acceptable then be sure to connect the appropriate test leads to the device under test (DUT) or test fixture. Be sure to connect this safety ground to a suitable known good ground before energizing this instrument, then connect the Return lead first (black) to the test fixture or item followed by the High Current output lead (red).

**WARNING** f). Please check your connections to be sure they are making good contact and that the test station or area is clear of debris and other personnel. **DO NOT TOUCH THE DEVICE UNDER TEST ONCE THE TEST HAS BEEN STARTED.** To initiate the test press the GREEN test button on the front panel. This is a momentary button and does not need to be held in the pressed position during the test. The instrument will then cycle ON and begin the automated test sequence using the defaults. If a failure occurs you will HEAR an audible alarm. To stop the alarm you must depress the RED button marked RESET. This will silence the alarm and reset the instrument to begin another test. This RESET button may also be used as a safety button

to quickly ABORT a test and cut off the HIGH CURRENT.

**TEST** When HIGH CURRENT is present a green TEST indicator located to the left of the CURRENT receptacle will light until the HIGH CURRENT is shut OFF. If the device under test PASSED, then a single beep will sound. In the case of a FAIL condition, the RESET SWITCH will illuminate and the LCD will display a failure condition along with an audible alarm. The instrument will provide a memory of the test condition results on the LCD display that will remain until the next test is initiated. Depressing the reset button will reset the instrument alarm while keeping the last test results on the display. Depressing the reset button a second time will clear the display.

**Quick Guide to Interconnecting HYAMP jr. to Hypot II  
Using the Supplied Interface Cable Kit HAJA-01.**

1. Connect the double ended banana plug cable from the Hypot II front RETURN jack to the HYAMP jr. INTERCONNECT jack. Determine whether you want to run the Ground Bond and Hipot test simultaneously or sequentially then select the appropriate cable assembly for your needs, using the descriptions in the table below.

| Cable number | Method       | Operation                                |
|--------------|--------------|--|
| 3030D-22     | Sequential   | HYAMP jr. first then Hypot II.           |
| 3030D-23     | Simultaneous | HYAMP jr. and Hypot II at the same time. |

Note: The cables are identified on the cable label.

2. Attach the male connector with two cables coming from it, to the female output connector of the HYAMP jr.. Attach the shorter of the two remaining cables with female connectors, to the male input connector of the HYAMP jr. and the longer cable to the male signal input/output connector on the rear panel of the Hypot II
3. Connect the spade lug of the high current lead (red) from the (optional) receptacle adapter box (37893) to the HYAMP jr. jack marked CURRENT (red), and the high voltage plug (white) to the Hypot II jack marked HV (white).
4. Connect the RETURN lead with the alligator clip (black) to the HYAMP jr. jack marked RETURN (black). The alligator clip should be connected to the DUT chassis.
5. Check the test parameters and initiate the tests by pressing the HYAMP jr. test button. The Reset buttons on both instruments are active to disable the tests or for failure reset.

- For a more detailed description on interconnecting your system, see page 28.

NOTE: When interconnecting HYAMP jr. to a model in the Hypot II family, HYAMP jr. will automatically sense when high voltage is active. The display on the HYAMP jr. will change to show a “W-On” indicating that the Dielectric Withstand test is processing. An example of this display is shown below. The initialization of the AC or DC Dielectric Withstand test will now be controlled by the HYAMP jr. through the interconnect cables.

|        |      |      |
|--------|------|------|
| Set    | M1   | 1.0s |
| 25.00A | W-On | 0mΩ  |



OPERATION INSTRUCTIONS FOR HYAMP jr.  
Model 3030D

**A. POWER UP:****CAUTION**

Check to be sure that the correct input line voltage has been selected on the rear panel, either 115 volts AC or 230 volts AC. Connect the power-input plug into its socket on the rear panel of the instrument. Connect the male end of the plug to the outlet receptacle.

Please be sure that the safety ground on the power line cord is not defeated and that you are connecting to a grounded power source. Also connect the rear panel chassis ground for additional safety.

Turn on the POWER switch located on the lower left-hand side of the front panel. Upon powering the instrument up a POWER ON SELF-TEST (POST) will be automatically performed. This test will check for the condition of the ram chips, led indicators, PCBs and other critical components. In addition the display will show the following message.

|  |
|--|
| ARI    HYAMP JR.<br>3030D    VER : X.X |
|--|

The instrument will recall the last memory program that was active and the display will show the parameters that were programmed into that memory. The instrument is now ready for operation.

**B. SETUP PROCEDURE:****1. Output Current Setting**

Please press the SET key, the display will show:

|                 |
|-----------------|
| CURRENT = XX.XA |
|-----------------|

Please use the Up (^) or Down (v) arrow keys to adjust the Current setting, then press the EXIT key to store the current setting and return to the Run mode, or press the SET key to advance to the next parameter. The maximum current which may be entered is 30.0 Amps. Any value above this will produce an ERROR message.

**2. High Limit Setting**

Please press the SET key until arriving at the HI-LMT setting. The display will show:

|                 |
|-----------------|
| HI-LMT = XXX mΩ |
|-----------------|

Please use the Up (^) or Down (v) arrow keys to adjust the value of the High Limit resistance trip point then press the EXIT key to store the setting and return to the Run

mode, or press the SET key to advance to the next parameter. The unit of measure is in milliohms with a range from 0-510mΩ.

### 3. Dwell Time Setting

Please press the SET key until arriving at the Timer setting. The display will show:

Timer = XXX.Xs

Use the Up (^) or Down (v) arrow keys to adjust the Timer setting, then press the EXIT key to store the Timer setting and return to the Run mode, or press the SET key to advance to the next parameter. The range is 0 to 999.9 seconds; if the Timer is set to 0, the instrument will operate in a continuous ON mode when the test button is depressed and released. It will stop when the DUT (Device Under Test) goes into failure or the manual reset button is pressed.

### 4. Frequency Setting

Please press the SET key until arriving at the Frequency setting. The display will show:

Freq = 50 HZ

or

Freq = 60 HZ

Use the Up (^) or Down (v) arrow keys to change the Frequency setting to 50Hz or 60Hz, then press the EXIT key to store the frequency setting and return to the Run mode, or press the SET key to advance to the next parameter.

### 5. Offset Setting

Please press the SET key until arriving at the Offset setting. The display will show:

Offset = XXX mΩ  
TEST to Auto Set

Please use the Up (^) or Down (v) arrow keys to adjust the setting of the offset manually, then press the EXIT key to store the setting and return to the Run mode, or press the SET key to advance to the next parameter. To automatically set the Offset, press the TEST button when the test leads or test fixture is connected across the Hyamp jr. outputs. The HYAMP jr. will measure the resistance that is present and enter this value into the Offset setting. This offset will be automatically subtracted from the actual resistance reading before the reading is displayed. The unit of measure is in milliohms with a range from 0-100mΩ.

## 6. Memory Storage and Recall

HYAMP jr. is equipped with a total of 5 memory programs numbered 1 through 5. This makes it possible to store all the various test parameters required, and quickly recall them for each of the different products that need to be tested.

### (A). Storage of a Memory Program

Please press the SET key until the display shows

Memory = X

Use the Up (^) or Down (v) arrow keys to select memory locations 1 through 5. After selecting the memory press the Set key to view the settings that have been recalled from memory or to make any changes to these settings. Once you have entered all the test parameters such as Current, Hi-Limit Trip Resistance, Dwell Time, etc., as outlined in the above procedures, press the Exit key to store any changes to the settings. The parameters are automatically updated into the memory location that was selected, when exiting to the test mode.

|       |    |        |
|-------|----|--------|
| Set   | MX | XXX.Xs |
| XX.XA |    | XXX mΩ |

### (B). Recall of a Memory Program

Please press the SET key until the Memory Program is displayed then press the Up (^) or Down (v) arrow keys until the specific memory you wish to recall is displayed. Pressing the EXIT key will activate this memory position. To start a test press the TEST button.

## 7. To Set Key Lock or Memory Lock

The HYAMP jr. is equipped with two different lockout selections. The first selection is Key Lock. Within this selection, you can lockout all front panel control functions except TEST and RESET. The second selection is Memory lock and is used in conjunction with the Key Lock. Within this selection, you can lockout all front panel control functions except TEST, RESET and memory select.

You can toggle this selection only from a power OFF state. Please turn the power switch to the off position then press and hold the SET key, then turn the power ON.

Momentarily you will see one of the following screens to indicate if the keys are locked or unlocked:

Key Lock = ON

or

Key Lock = OFF

To toggle the Key Lock function on and off use the up or down arrow keys, then press exit to select, or press the set key again to reach the Memory Lock screens.

The memory lock screens appear as follows:

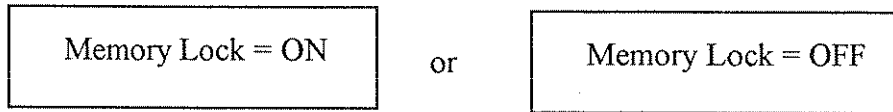

To toggle the Memory Lock function on and off use the up or down arrow keys, then press exit to select, or press the set key again to reach the Key Lock screens.

Use the following chart to set the Key Lock and Memory Lock for your application.

| Key Lock | Memory Lock | Accessible keys                                      |
|----------|-------------|--|
| Off      | Off         | All  |
| Off      | On          | All  |
| On       | Off         | TEST, RESET, and up-down arrows for memory selection |
| On       | On          | TEST and RESET                                       |

### C. OPERATING PROCEDURES:

1. If the defaults are acceptable then be sure to connect the appropriate test leads to the device under test (DUT) or test fixture. Be sure to connect the safety ground (on the rear panel) to a suitable known good ground before energizing this instrument. Then connect the return lead first to the test fixture or the DUT followed by the high current lead. Check your connections to be sure they are making good contact and that the test station or area is clear of debris or other personnel.

**DO NOT TOUCH THE DEVICE UNDER TEST ONCE THE TEST HAS BEEN STARTED.**

**WARNING** 2. Please follow the setup procedures to set or recall setups from memory programs. The display will show the number of the Memory Program and the value of Dwell time, Test Current and High Limit resistance trip point as follows:

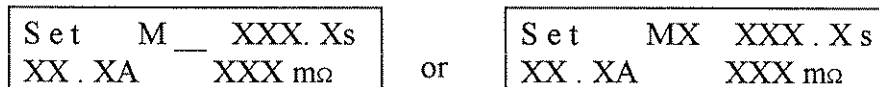

If the set data is to be stored in the memory program, please follow the procedure outlined in the setup procedures on **Storage of Memory Program**.

3. To initiate a test press the TEST switch on the front panel. The instrument will output the set current for the length of time set on the dwell timer. The display will show:

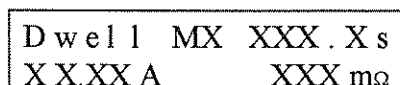

4. If the resistance exceeds the high limit trip setting but does not exceed the metering range, the red RESET switch will illuminate and the alarm will be activated.

The display will show:

|          |    |           |
|----------|----|-----------|
| HI - LMT | MX | XXX . X s |
| XX . XA  |    | XXX mΩ    |

If the resistance exceeds the high limit trip setting and exceeds the metering range, the red RESET switch will illuminate and the alarm will sound. The display will show:

|          |    |           |
|----------|----|-----------|
| HI - LMT | MX | XXX . X s |
| XX . XA  |    | OFL mΩ    |

To stop the alarm, please press the RESET switch once. The alarm will stop and the display will retain the failure information. If the RESET switch is pressed again, the data on the display screen will be cleared and the display will indicate the setting data from the last test. The instrument is now ready for the next test.

5. If the test leads are left open or the resistance is so large that the test current generates more than the maximum limit of 6VAC, then red RESET switch will illuminate and the alarm will sound. The display will show:

|         |    |           |
|---------|----|-----------|
| V-OVLD  | MX | XXX . X s |
| XX . XA |    | >6VAC     |

To stop the alarm, please press the RESET switch once. The alarm will stop and the display will retain the failure information. If the RESET switch is pressed again, the data on the display screen will be cleared and the display will indicate the setting data from the last test. The instrument is now ready for the next test.

6. If the DUT passed all of the tests, the LCD will indicate a pass condition and the instrument will output a short audible beep tone to indicate the DUT has passed the tests. The instrument is now ready to perform another test.

The display will show:

|         |    |           |
|---------|----|-----------|
| Pass    | MX | XXX . X s |
| XX . XA |    | XXX mΩ    |

7. If the operator elects to abort a test in process this can be accomplished by pressing the RESET switch at anytime. The instrument will stop the test process immediately.

The display will show:

|         |    |           |
|---------|----|-----------|
| Abort   | MX | XXX . X s |
| XX . XA |    | XXX mΩ    |

Please press the TEST switch to initiate another test.

**D. CONNECTION OF REMOTE I/O:**

Two 9 pin D type connectors are mounted on the rear panel that provide REMOTE-INPUT-OUTPUT control and information. These connectors mate with standard 9 pin D subminiature connector provided by the user. The output mates to a male (plug) connector while the input mates to a female (receptacle) connector. For best performance a shielded cable should be used. To avoid ground loops the shield should not be grounded at both ends of the cable. Suggested AMP part numbers for interconnecting to the Remote I/O are shown below.

- 205204-4 PLUG SHELL WITH GROUND INDENTS
- 205203-3 RECEPTACLE SHELL
- 745254-7 CRIMP SNAP-IN PIN CONTACT (for plug)
- 745253-7 CRIMP SNAP-IN SOCKET CONTACT (for receptacle)
- 745171-1 SHIELDED CABLE CLAMP (for either plug or receptacle)
- 747784-3 JACKSCREW SET (2)

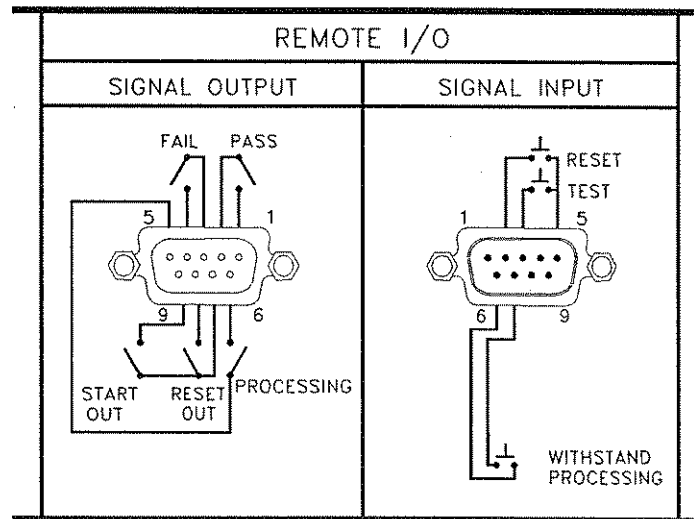
**REMOTE INTERFACE REAR PANEL:**

**SIGNAL OUTPUTS ON REMOTE I/O**

The rear panel connector provides three output signals to remotely monitor PASS, FAIL, and PROCESSING conditions, and it also provides a RESET OUT pulse signal and a START OUT pulse signal. The monitoring signals are provided by three normally open internal relays that switch on to indicate the current condition of the tester. The RESET OUT signal and the START OUT pulse signal are also provided by a normally open internal relay. The RESET OUT gives a signal whenever the reset function is activated. This can be used to abort a Dielectric Withstand test while the units are interfaced as a test system. The START OUT gives a momentary output pulse at the end of the Ground Bond test that can be used to start the Hipot test. These are normally open free contacts and will not provide any voltage or current. The ratings of the contacts are 1A / 250 VAC

(0.5 ADC). The signal outputs are provided on the 9 pin female type D connector. Below is a listing that indicates what conditions activate each pin. When a terminal becomes active the relay closes thereby allowing the external voltage to operate an external device.

Pins 1 and 2 provide the PASS signal.

Pins 3 and 4 provide the FAIL signal.

Pins 5 and 6 provide the PROCESSING signal.

Pins 7 and 8 provide the RESET OUT signal.

Pins 7 and 9 provide the START OUT pulse signal.

The following describes how the relays operate for each test condition.

**PROCESSING** - The relay contact closes the connection between pin (5) and pin (6) while the instrument is performing a test. The connection is opened at the end of the test.

**PASS** - The relay contact closes the connection between pin (1) and pin (2) after detecting that the item under test passed all tests. The connection is opened when the next test is initiated or the reset function is activated.

**FAIL** - The relay contact closes the connection between pin (3) and pin (4) after detecting that the item under test failed any test. The connection is opened when the next test is initiated or the reset function is activated.

**RESET OUT** - The relay contact closes the connection between pin (7) and pin (8) while the reset function is activated. This is only a continuous closure dependent on the length of time the reset button is held in an active state.

**START OUT** - The relay contact closes the connection between pin (7) and pin (9) momentarily after the completion and pass of the Ground Bond test. This is only a momentary closure, and therefore, the contact does not stay closed.

With the HYAMP jr. and the Hypot II being used as a test system, the processing signal from the Hipot tester will be sent across pin (6) and pin (7) of the HYAMP jr. remote input. This signal will add to the LCD display a W-On Withstand Processing indicator that notifies the operator that high voltage is enabled.

#### **E. HYAMP jr. AND Hypot II INTERCONNECTION:**

The two instruments have been designed to interface and work as one test system. The tests may be performed in sequence, where the Ground Bond test is run to verify the ground integrity and then the Hipot test is run after a good ground is indicated. The two tests can also be run simultaneously. Instructions regarding connections are provided in the next section. Also, refer to the end of section E for a complete diagram of a basic test setup.

After configuring the required test parameters for both instruments and connecting the cables, the test cycle can be initiated by activating the front panel test button on HYAMP

jr.. The Hipot test will be controlled by the Hyamp jr. automatically, through the interconnecting control cables.

**1. INSTRUCTIONS FOR USER-FABRICATED INTERCONNECT CABLES.**

The following diagrams show how to connect to the Remote I/O of both units. The associated pin numbers are given for the connectors on both units and the pins to be wired together. Refer to section **D** of this manual for the required parts to make these cables.

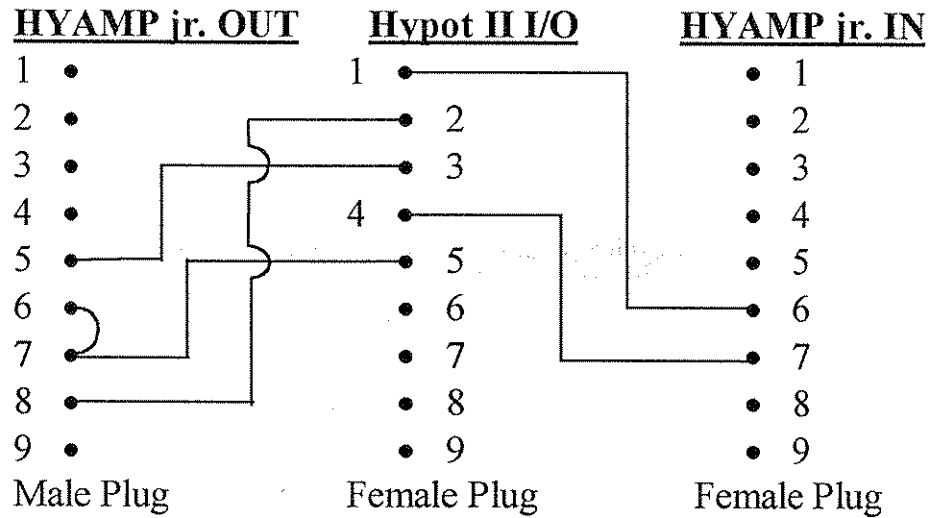

**A. Sequential Testing**

HYAMP jr. \ Hypot II Sequential Connection

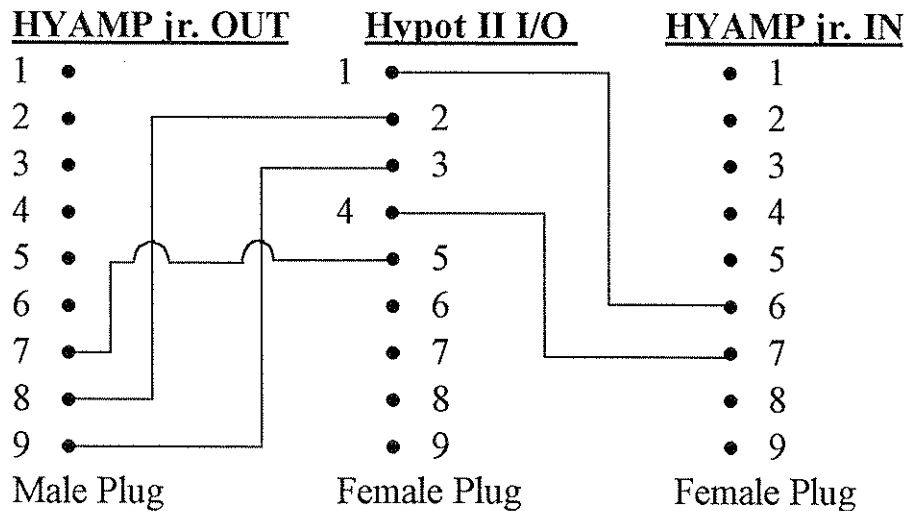

**B. Simultaneous Testing**

HYAMP jr. \ Hypot II Simultaneous Connections



**RETURN CABLE CONNECTION**

For the return cable connection, it is suggested that two insulated banana plugs be used with 18AWG stranded wire. For proper connection, one end of the return cable should be connected to the RETURN jack on the front panel of the Hypot II and the other end connected to the INTERCONNECT jack on the front panel of the HYAMP jr. The suggested E.F. Johnson part number for the banana plug is as follows:

108-0303-001      Banana Plug Insulated (2)

**2. INTERCONNECTING WITH THE HAJA-01 ACCESSORY CABLE**

Accessory kit HAJA-01 includes the rear interface cables needed for interfacing the HYAMP jr. with the Hypot II . The following table lists the kit contents.

| Part Number | Description                               | Qty. |
|-------------|---|------|
| HS-8-11     | Cable Assembly Return Interconnect        | 1    |
| 3030D-22    | Cable Assembly R/P Interface Sequential   | 1    |
| 3030D-23    | Cable Assembly R/P Interface Simultaneous | 1    |
| 37893       | Adapter Box High Voltage High Current     | 1    |

The following sections describe the procedures for interconnecting your units. Please refer to the test method you require for specific cable connection instructions.

**Cable Connections.**

First locate the HS-8-11 return cable, identified by its double banana plug connectors. Connect one end to the RETURN jack on the front panel of the Hypot II and the other end to the INTERCONNECT jack on the front panel of the HYAMP jr.

Determine whether you want to run the Ground Bond and Hipot test simultaneously or sequentially then select the appropriate cable assembly for your needs, using the descriptions in the table above. Attach the male connector with two cables coming from it, to the female output connector of the HYAMP jr. Attach the shorter of the two remaining cables with female connectors, to the male input connector of the HYAMP jr. and the longer cable to the male signal input/output connector on the rear panel of the Hypot II.

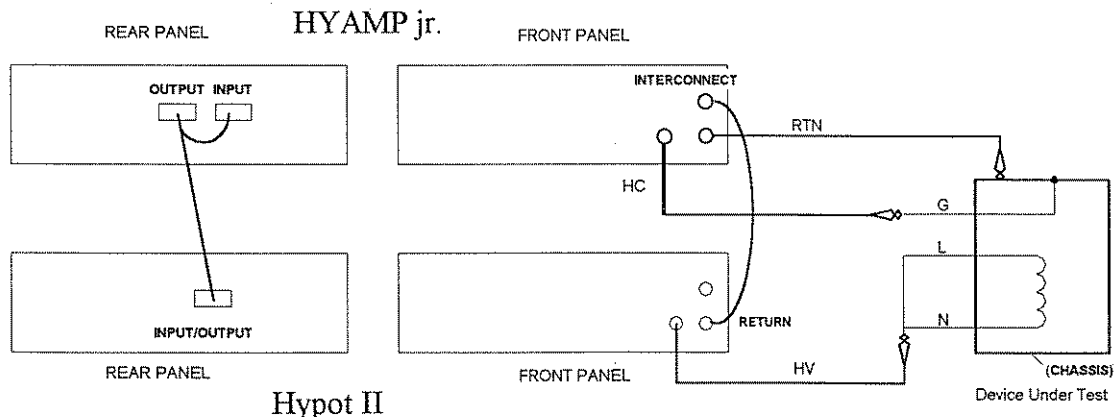

***Basic Test Setup***

**F. ADAPTER BOX CONNECTION**

The following diagram shows how to connect the adapter box to the HYAMP jr. and the Device Under Test. This adapter box allows the user an easy way to connect an item that is terminated in a three-prong line cord. The high current is wired to the ground pin of the receptacle box and from there the test is performed on the ground conductor of the DUT to the chassis or dead metal of the product. If the high voltage lead is not used, it should be secured out of the way.

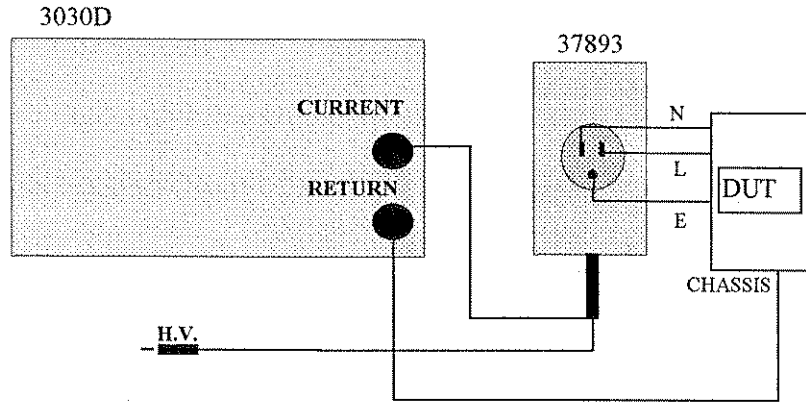

**Test Connections**

If the HYAMP jr. and the Hypot II are being used as a test system, the high voltage lead should be plugged into the high voltage jack on the front panel of the Hypot II. The return lead from the Hypot II should be connected to the HYAMP jr. as described in the previous section (Cable Connections). This configuration would allow you to do both the Ground Bond and Hipot tests by pushing a single test button on the HYAMP jr. once all connections are made and the test parameters are set up.

**MODEL 3030D OPTIONS**

**Introduction**

This section contains a list with descriptions of available factory installed options at the time of this printing.

**Option Label**

If your instrument has been modified with options, there will be an option label on the rear panel of the unit. The option label contains an option(s) code that may be cross-referenced to the 3030D Options List.

The option(s) code would appear as follows:

fitted with option 02 ..... OPT: 02  
 fitted with option 02 and 03..... OPT: 0203

**3030D Options List**

| Code | Description  |
|------|--------------|
| 01   | Rear Outputs |
| 02   | TBA          |
| 03   | TBA          |

**Description**

**01 Rear Outputs**

The Rear Outputs option gives the user the capability to access the High Current, Return and Interconnect outputs from the rear panel for use in automated systems. The configuration and descriptions are as follows.

**OPTIONAL REAR PANEL CONTROLS**

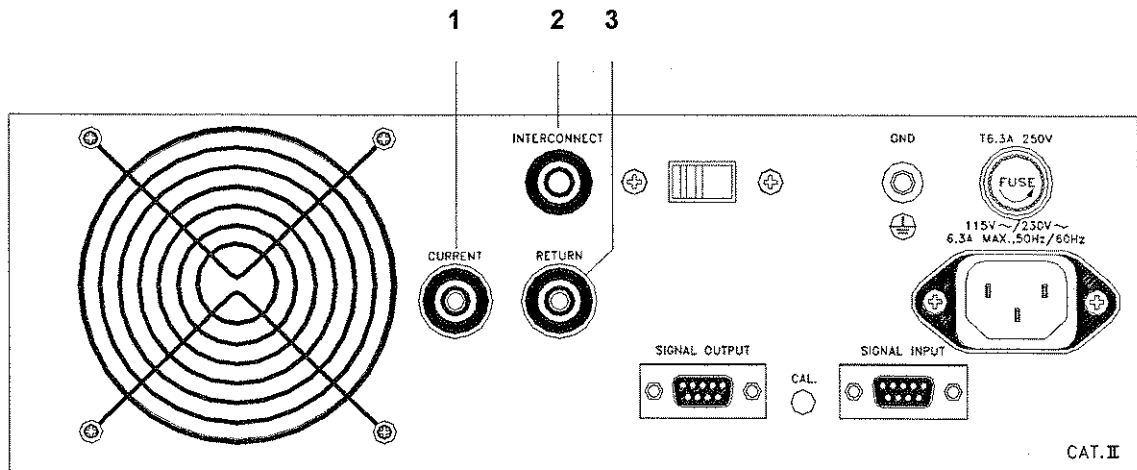

**1. CURRENT OUTPUT JACK:** For the connection of the detachable 5-foot (1.52 m)

1. **CURRENT OUTPUT JACK:** For the connection of the detachable 5-foot (1.52 m) red test lead. This jack is always used when performing a Ground Bond test.
2. **INTERCONNECT JACK:** For the connection of the return lead from the Hipot tester used when performing both Hipot and Ground Bond tests on the same test item.
3. **RETURN OUTPUT JACK:** For the connection of the detachable 5-foot (1.52 m) black return test lead. This jack is always used when performing a test.

This page left intentionally blank.

**SECTION 2**  
**SERVICE MANUAL**

## **CALIBRATION PROCEDURES**

This instrument has been fully calibrated at the factory in accordance to our published specifications. It has been calibrated with standards traceable to NIST. You will find in this manual a copy of the Certificate of Calibration. It is recommended that you have this instrument recalibrated and a safety check done at least once per year. AR recommends you use Calibration Standards that are NIST traceable, or traceable to agencies recognized by NIST to keep this instrument within published specifications. End user metrology standards or practices may vary. These metrology standards determine the measurement uncertainty ratio of the calibration standards being used. Calibration adjustments can only be made in the Calibration mode, calibration checks can only be made in the Test mode of operation.

### **Calibration Equipment Required:**

The following equipment will be needed to properly calibrate your instrument.

Digital Multimeter with the minimum ranges;

ac voltage: 10 VAC

ac current: 30 AAC.

### **CALIBRATION PROCEDURE:**

To enter the calibration mode the instrument must be in the OFF position. Using a pen or small screw driver, press and hold the rear panel recessed calibration key, then turn on the Input Power Switch. The display will show:

Calibration Mode  
Set: V v: A

Press the SET key for volts calibration or the Down (v) arrow key for amps.

#### **1. Calibration of Voltage**

Equipment needed: STANDARD AC VOLTMETER capable of measuring 10VAC.

Please connect a standard ac voltmeter with 10V minimum full-scale range to the current and return connectors. Then press the SET key on the front panel. The instrument will provide approximately 6.0VAC on the output connectors and the display will show:

Voltage = \_\_ V

Please use the Up (^) or Down (v) arrow keys to enter the reading from the ac voltmeter into the instrument, then press the SET key to store the voltage setting. To exit without changing the calibration, press the EXIT key.

## 2. Calibration of Current

Equipment needed: STANDARD AC AMMETER with a range of 30A.

Please connect the standard ac ammeter across the output leads of the instrument. Press the Down (v) arrow key. The instrument will provide around 30A on the output and the display will show:

Current = \_      A

Please use the Up (^) or Down (v) arrow keys to enter the reading of the standard ac ammeter into the instrument, then press the SET key to store the current setting. To exit without changing the calibration, press the EXIT key.

## 3. Exit Calibration Mode

After the calibration is complete, turn the input power switch to OFF (O) to exit the Calibration Mode. Turn the power switch to ON (I) to return to standard operating test mode for calibration verification.



## Replacement Parts List HYAMP jr.

Model 3030D

Rev. B 2-4-99 ECO 4697

| Part Number | Qty | Reference Designator | Description                         |
|-------------|-----|----------------------|-------------------------------------|
| 37515       | 1   | CSW-01               | PCB Assy Input Protection Board     |
| 37593       | 1   | CKB-02               | PCB Assy Keyboard Assembly          |
| 37955       | 1   | 3030                 | PCB Assy Main Control Board         |
| 37956       | 1   | AMP-260              | PCB Assy Main Power Amplifier Board |
| 37957       | 1   | REC-18               | PCB Assy Rectifier Board            |
| 37571       | 1   |                      | Earth Connector                     |
| 37631       | 2   |                      | Diode Rectify Bridge 50V/50A        |
| 37697       | 1   |                      | IC 89C52 Microcontroller 8-bit      |
| 37698       | 4   |                      | Foot Plastic Molded                 |
| 37699       | 2   |                      | Foot Metal Wire Frame               |
| 37700       | 4   |                      | Foot Pad Rubber Adhesive            |
| 37554       | 1   |                      | LCD Display 16 x 2 Characters       |
| 33189       | 1   |                      | Line Cord (Mains)                   |
| 37555       | 1   |                      | Power Switch 2P 10A/250V            |
| 35999       | 1   |                      | Return Connector Black Banana Jack  |
| 37673       | 1   |                      | Switch Reset, Red                   |
| 37497       | 1   |                      | Switch Test, Green                  |
| 38017       | 1   | T1                   | Transformer Input, Toroidal         |
| 37780       | 1   | -                    | Fuse 6.3A 250V, Slow Blow, 20mm     |
| 37781       | 1   | -                    | Fuse Holder, 20mm                   |
| 37953       | 1   |                      | Cable Assy High Current Return Lead |
| 37954       | 1   |                      | Cable Assy High Current Output Lead |
| 37882       | 1   |                      | High Current Return Jack            |
| 37883       | 1   |                      | High Current Output Jack            |

### Accessories

| Part Number | Qty. | Description                               |
|-------------|------|---|
| HS-8-11     | 1    | Cable Assembly Return Interconnect        |
| 3030D-22    | 1    | Cable Assembly R/P Interface Sequential   |
| 3030D-23    | 1    | Cable Assembly R/P Interface Simultaneous |
| 37893       | 1    | Adapter Box High Voltage High Current     |

**SCHEMATIC INDEX**

| <b>Drawing Number</b> | <b>Description</b>     | <b>Reference Designator</b> | <b>Pages</b> |
|-----------------------|------------------------|-----------------------------|--------------|
| S03030D               | Wiring Diagram         | -                           | 1            |
| S37955                | Main Control Board     | 3030                        | 3            |
| S37956                | Power Amplifier Board  | AMP-260                     | 1            |
| S37593                | Keypad Board           | CKB-02                      | 1            |
| S37515                | Input Protection Board | CSW-01                      | 1            |
| S37957                | Rectifier Board        | REC-18                      | 1            |
| S38220                | ROM Conversion Board   | 82147                       | 1            |

1 2 3 4 5 6

| REVISIONS |             | ECO# | DATE | APPR | CHK |
|-----------|-------------|------|------|------|-----|
| SYM       | DESCRIPTION |      |      |      |     |

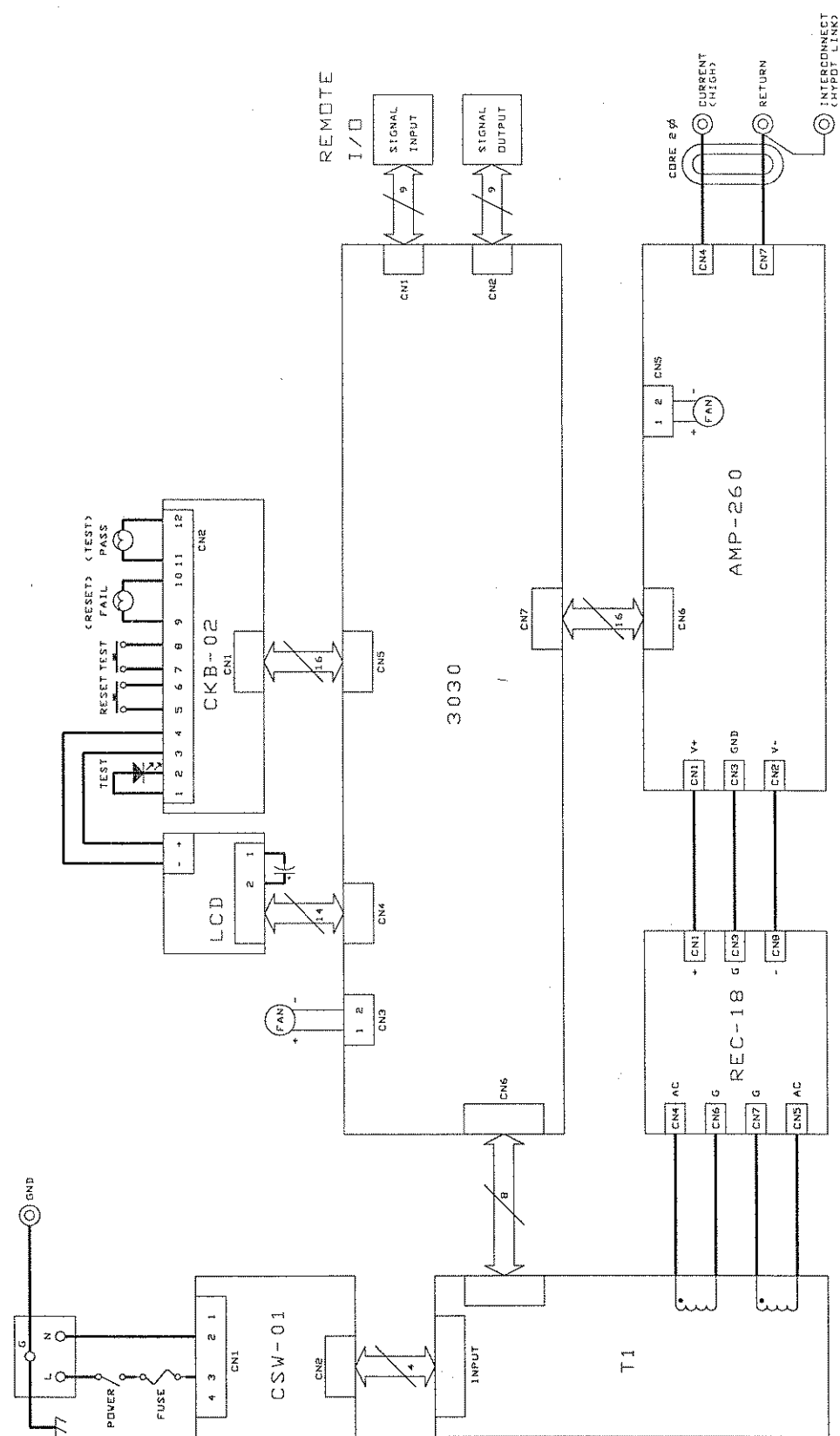

FILE: S3030D.DWG



USED ON MODEL/ASSY  
3030D

SCHEMATIC  
3030D  
WIRING DIAGRAM

|          |     |          |       |              |
|----------|-----|----------|-------|--------------|
| DRAWN    | CPY | 04.13.98 | SIZE  | REV          |
| CHECKED  | LL  | 6.30.98  | A     | S3030D       |
| APPROVED | RB  | 6.30.98  | SCALE | NONE         |
|          |     |          |       | SHEET 1 OF 1 |

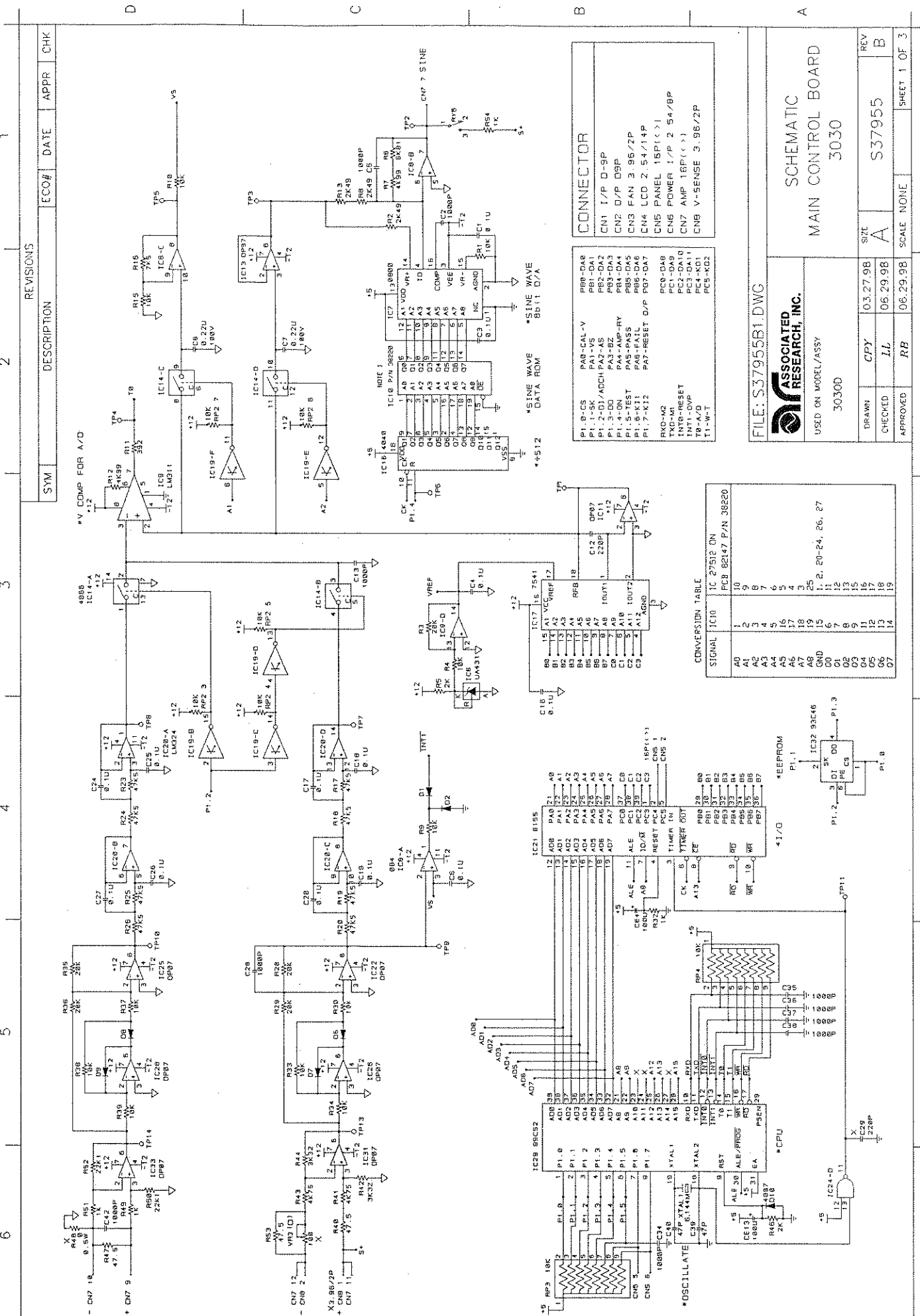

| REV | DATE | APPR | CHK |
|-----|------|------|-----|
| 1   |      |      |     |

| SYM | DESCRIPTION | ECO# |
|-----|-------------|------|
|     |             |      |

| REV | DATE | APPR | CHK |
|-----|------|------|-----|
| 1   |      |      |     |

| REV | DATE | APPR | CHK |
|-----|------|------|-----|
| 1   |      |      |     |

| REV | DATE | APPR | CHK |
|-----|------|------|-----|
| 1   |      |      |     |

| REV | DATE | APPR | CHK |
|-----|------|------|-----|
| 1   |      |      |     |

| REV | DATE | APPR | CHK |
|-----|------|------|-----|
| 1   |      |      |     |

| REV | DATE | APPR | CHK |
|-----|------|------|-----|
| 1   |      |      |     |

| REV | DATE | APPR | CHK |
|-----|------|------|-----|
| 1   |      |      |     |

| REV | DATE | APPR | CHK |
|-----|------|------|-----|
| 1   |      |      |     |

| REV | DATE | APPR | CHK |
|-----|------|------|-----|
| 1   |      |      |     |

| REV | DATE | APPR | CHK |
|-----|------|------|-----|
| 1   |      |      |     |

| REV | DATE | APPR | CHK |
|-----|------|------|-----|
| 1   |      |      |     |

| REV | DATE | APPR | CHK |
|-----|------|------|-----|
| 1   |      |      |     |

| REV | DATE | APPR | CHK |
|-----|------|------|-----|
| 1   |      |      |     |

| REV | DATE | APPR | CHK |
|-----|------|------|-----|
| 1   |      |      |     |

| REV | DATE | APPR | CHK |
|-----|------|------|-----|
| 1   |      |      |     |

| REV | DATE | APPR | CHK |
|-----|------|------|-----|
| 1   |      |      |     |

| REV | DATE | APPR | CHK |
|-----|------|------|-----|
| 1   |      |      |     |

| REV | DATE | APPR | CHK |
|-----|------|------|-----|
| 1   |      |      |     |

| REV | DATE | APPR | CHK |
|-----|------|------|-----|
| 1   |      |      |     |

| REV | DATE | APPR | CHK |
|-----|------|------|-----|
| 1   |      |      |     |

| REV | DATE | APPR | CHK |
|-----|------|------|-----|
| 1   |      |      |     |

| REV | DATE | APPR | CHK |
|-----|------|------|-----|
| 1   |      |      |     |

| REV | DATE | APPR | CHK |
|-----|------|------|-----|
| 1   |      |      |     |

| REV | DATE | APPR | CHK |
|-----|------|------|-----|
| 1   |      |      |     |

| REV | DATE | APPR | CHK |
|-----|------|------|-----|
| 1   |      |      |     |

| REV | DATE | APPR | CHK |
|-----|------|------|-----|
| 1   |      |      |     |

| REV | DATE | APPR | CHK |
|-----|------|------|-----|
| 1   |      |      |     |

| REV | DATE | APPR | CHK |
|-----|------|------|-----|
| 1   |      |      |     |

FILE: S37955B1.DWG



USED ON MODEL/ASSY  
3030D

| DRAWN | COPY | CHECKED | APPROVED | DATE     | SCALE | SHEET | OF |
|-------|------|---------|----------|----------|-------|-------|----|
| REV   | CPY  | CHK     | APP      | DATE     | SCALE | SHEET | OF |
| B     | A    | IL      | RB       | 06.29.98 | NONE  | 1     | 3  |

SCHEMATIC  
MAIN CONTROL BOARD  
3030

CONNECTOR

|     |                   |
|-----|-------------------|
| CN1 | I/P D-9P          |
| CN2 | D/P D9P           |
| CN3 | FAN 3.95/2P       |
| CN4 | LCD 2.54/114P     |
| CN5 | POWER I/P 2.54/2P |
| CN6 | AMP 18P(<>)       |
| CN7 | AMP 18P(<>)       |
| CN8 | V-SENSE 3.95/2P   |

| IC    | DESCRIPTION |
|-------|-------------|
| IC1   | PAR-CAL-V   |
| IC2   | PAR-VS      |
| IC3   | PA3-BZ      |
| IC4   | PA3-BZ      |
| IC5   | PA3-BZ      |
| IC6   | PA3-BZ      |
| IC7   | PA3-BZ      |
| IC8   | PA3-BZ      |
| IC9   | PA3-BZ      |
| IC10  | PA3-BZ      |
| IC11  | PA3-BZ      |
| IC12  | PA3-BZ      |
| IC13  | PA3-BZ      |
| IC14  | PA3-BZ      |
| IC15  | PA3-BZ      |
| IC16  | PA3-BZ      |
| IC17  | PA3-BZ      |
| IC18  | PA3-BZ      |
| IC19  | PA3-BZ      |
| IC20  | PA3-BZ      |
| IC21  | PA3-BZ      |
| IC22  | PA3-BZ      |
| IC23  | PA3-BZ      |
| IC24  | PA3-BZ      |
| IC25  | PA3-BZ      |
| IC26  | PA3-BZ      |
| IC27  | PA3-BZ      |
| IC28  | PA3-BZ      |
| IC29  | PA3-BZ      |
| IC30  | PA3-BZ      |
| IC31  | PA3-BZ      |
| IC32  | PA3-BZ      |
| IC33  | PA3-BZ      |
| IC34  | PA3-BZ      |
| IC35  | PA3-BZ      |
| IC36  | PA3-BZ      |
| IC37  | PA3-BZ      |
| IC38  | PA3-BZ      |
| IC39  | PA3-BZ      |
| IC40  | PA3-BZ      |
| IC41  | PA3-BZ      |
| IC42  | PA3-BZ      |
| IC43  | PA3-BZ      |
| IC44  | PA3-BZ      |
| IC45  | PA3-BZ      |
| IC46  | PA3-BZ      |
| IC47  | PA3-BZ      |
| IC48  | PA3-BZ      |
| IC49  | PA3-BZ      |
| IC50  | PA3-BZ      |
| IC51  | PA3-BZ      |
| IC52  | PA3-BZ      |
| IC53  | PA3-BZ      |
| IC54  | PA3-BZ      |
| IC55  | PA3-BZ      |
| IC56  | PA3-BZ      |
| IC57  | PA3-BZ      |
| IC58  | PA3-BZ      |
| IC59  | PA3-BZ      |
| IC60  | PA3-BZ      |
| IC61  | PA3-BZ      |
| IC62  | PA3-BZ      |
| IC63  | PA3-BZ      |
| IC64  | PA3-BZ      |
| IC65  | PA3-BZ      |
| IC66  | PA3-BZ      |
| IC67  | PA3-BZ      |
| IC68  | PA3-BZ      |
| IC69  | PA3-BZ      |
| IC70  | PA3-BZ      |
| IC71  | PA3-BZ      |
| IC72  | PA3-BZ      |
| IC73  | PA3-BZ      |
| IC74  | PA3-BZ      |
| IC75  | PA3-BZ      |
| IC76  | PA3-BZ      |
| IC77  | PA3-BZ      |
| IC78  | PA3-BZ      |
| IC79  | PA3-BZ      |
| IC80  | PA3-BZ      |
| IC81  | PA3-BZ      |
| IC82  | PA3-BZ      |
| IC83  | PA3-BZ      |
| IC84  | PA3-BZ      |
| IC85  | PA3-BZ      |
| IC86  | PA3-BZ      |
| IC87  | PA3-BZ      |
| IC88  | PA3-BZ      |
| IC89  | PA3-BZ      |
| IC90  | PA3-BZ      |
| IC91  | PA3-BZ      |
| IC92  | PA3-BZ      |
| IC93  | PA3-BZ      |
| IC94  | PA3-BZ      |
| IC95  | PA3-BZ      |
| IC96  | PA3-BZ      |
| IC97  | PA3-BZ      |
| IC98  | PA3-BZ      |
| IC99  | PA3-BZ      |
| IC100 | PA3-BZ      |

CONVERSION TABLE

| SIGNAL | IC  | IC 27512 ON         |
|--------|-----|---------------------|
| A0     | 1   | PCB 82147 P/N 38220 |
| A1     | 2   |                     |
| A2     | 3   |                     |
| A3     | 4   |                     |
| A4     | 5   |                     |
| A5     | 6   |                     |
| A6     | 7   |                     |
| A7     | 8   |                     |
| A8     | 9   |                     |
| A9     | 10  |                     |
| A10    | 11  |                     |
| A11    | 12  |                     |
| A12    | 13  |                     |
| A13    | 14  |                     |
| A14    | 15  |                     |
| A15    | 16  |                     |
| A16    | 17  |                     |
| A17    | 18  |                     |
| A18    | 19  |                     |
| A19    | 20  |                     |
| A20    | 21  |                     |
| A21    | 22  |                     |
| A22    | 23  |                     |
| A23    | 24  |                     |
| A24    | 25  |                     |
| A25    | 26  |                     |
| A26    | 27  |                     |
| A27    | 28  |                     |
| A28    | 29  |                     |
| A29    | 30  |                     |
| A30    | 31  |                     |
| A31    | 32  |                     |
| A32    | 33  |                     |
| A33    | 34  |                     |
| A34    | 35  |                     |
| A35    | 36  |                     |
| A36    | 37  |                     |
| A37    | 38  |                     |
| A38    | 39  |                     |
| A39    | 40  |                     |
| A40    | 41  |                     |
| A41    | 42  |                     |
| A42    | 43  |                     |
| A43    | 44  |                     |
| A44    | 45  |                     |
| A45    | 46  |                     |
| A46    | 47  |                     |
| A47    | 48  |                     |
| A48    | 49  |                     |
| A49    | 50  |                     |
| A50    | 51  |                     |
| A51    | 52  |                     |
| A52    | 53  |                     |
| A53    | 54  |                     |
| A54    | 55  |                     |
| A55    | 56  |                     |
| A56    | 57  |                     |
| A57    | 58  |                     |
| A58    | 59  |                     |
| A59    | 60  |                     |
| A60    | 61  |                     |
| A61    | 62  |                     |
| A62    | 63  |                     |
| A63    | 64  |                     |
| A64    | 65  |                     |
| A65    | 66  |                     |
| A66    | 67  |                     |
| A67    | 68  |                     |
| A68    | 69  |                     |
| A69    | 70  |                     |
| A70    | 71  |                     |
| A71    | 72  |                     |
| A72    | 73  |                     |
| A73    | 74  |                     |
| A74    | 75  |                     |
| A75    | 76  |                     |
| A76    | 77  |                     |
| A77    | 78  |                     |
| A78    | 79  |                     |
| A79    | 80  |                     |
| A80    | 81  |                     |
| A81    | 82  |                     |
| A82    | 83  |                     |
| A83    | 84  |                     |
| A84    | 85  |                     |
| A85    | 86  |                     |
| A86    | 87  |                     |
| A87    | 88  |                     |
| A88    | 89  |                     |
| A89    | 90  |                     |
| A90    | 91  |                     |
| A91    | 92  |                     |
| A92    | 93  |                     |
| A93    | 94  |                     |
| A94    | 95  |                     |
| A95    | 96  |                     |
| A96    | 97  |                     |
| A97    | 98  |                     |
| A98    | 99  |                     |
| A99    | 100 |                     |

KEEPROM

|      |       |
|------|-------|
| IC32 | 93C46 |
| IC33 | 93C46 |
| IC34 | 93C46 |
| IC35 | 93C46 |
| IC36 | 93C46 |
| IC37 | 93C46 |
| IC38 | 93C46 |
| IC39 | 93C46 |
| IC40 | 93C46 |
| IC41 | 93C46 |
| IC42 | 93C46 |
| IC43 | 93C46 |
| IC44 | 93C46 |
| IC45 | 93C46 |
| IC46 | 93C46 |
| IC47 | 93C46 |
| IC48 | 93C46 |
| IC49 | 93C46 |
| IC50 | 93C46 |
| IC51 | 93C46 |
| IC52 | 93C46 |
| IC53 | 93C46 |
| IC54 | 93C46 |
| IC55 | 93C46 |
| IC56 | 93C46 |
| IC57 | 93C46 |
| IC58 | 93C46 |
| IC59 | 93C46 |
| IC60 | 93C46 |
| IC61 | 93C46 |
| IC62 | 93C46 |
| IC63 | 93C46 |
| IC64 | 93C46 |
| IC65 | 93C46 |
| IC66 | 93C46 |
| IC67 | 93C46 |
| IC68 | 93C46 |
| IC69 | 93C46 |
| IC70 | 93C46 |
| IC71 | 93C46 |
| IC72 | 93C46 |
| IC73 | 93C46 |
| IC74 | 93C46 |
| IC75 | 93C46 |
| IC76 | 93C46 |
| IC77 | 93C46 |
| IC78 | 93C46 |
| IC79 | 93C46 |
| IC80 | 93C46 |
| IC81 | 93C46 |
| IC82 | 93C46 |
| IC83 | 93C46 |
| IC84 | 93C46 |
| IC85 | 93C   |

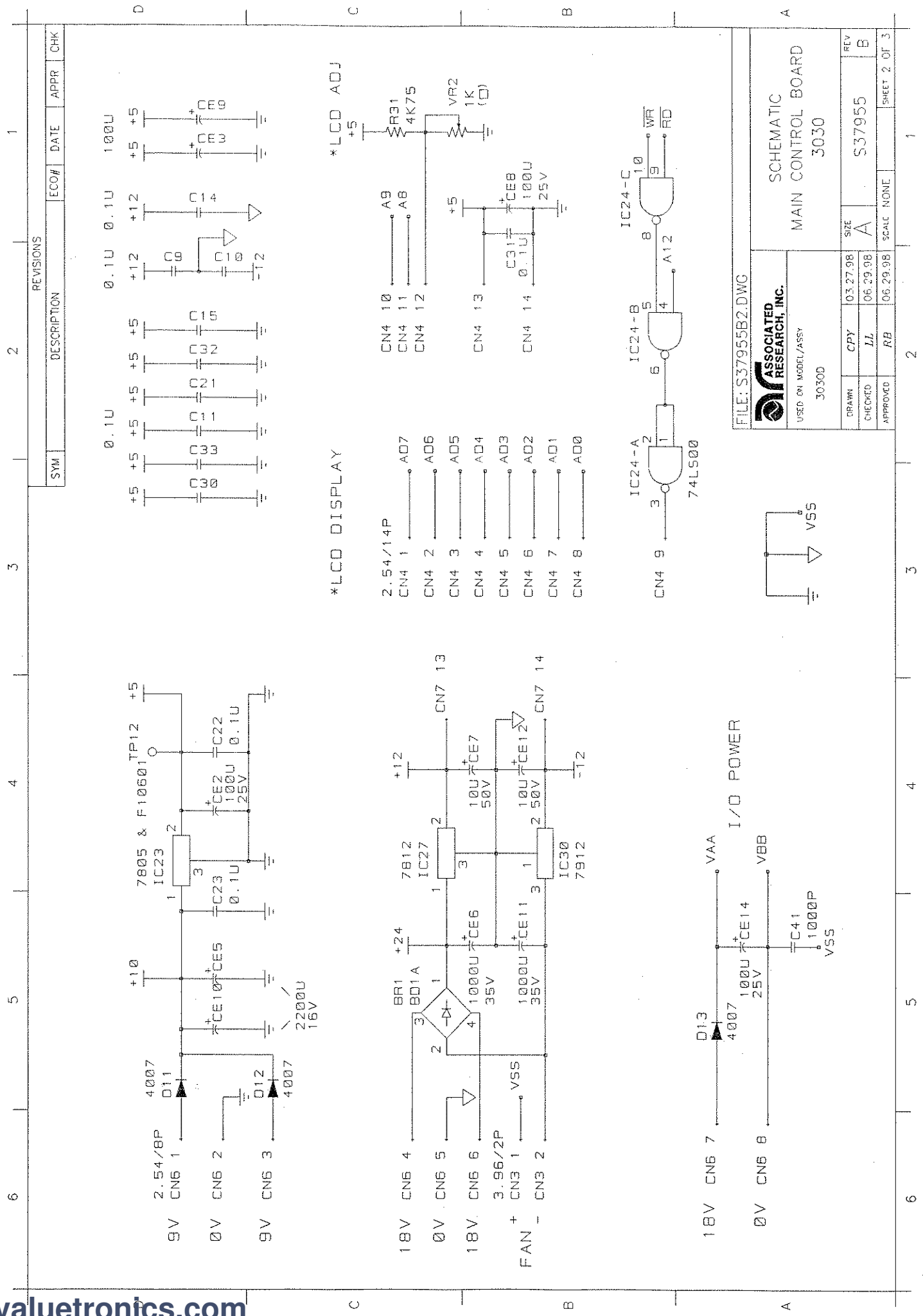

| REVISIONS |             |      |      |      |     |
|-----------|-------------|------|------|------|-----|
| SYM       | DESCRIPTION | ECO# | DATE | APPR | CHK |
|           |             |      |      |      |     |

FILE: S37955B2.DWG



USED ON MODEL/ASSY  
3030D

SCHEMATIC  
MAIN CONTROL BOARD  
3030

| DRAWN | CPY | SIZE | REV |
|-------|-----|------|-----|
| LL    | LL  | A    | B   |

| APPROVED | SCALE | NONE | SHEET 2 OF 3 |
|----------|-------|------|--------------|
| RB       | RB    | NONE | SHEET 2 OF 3 |

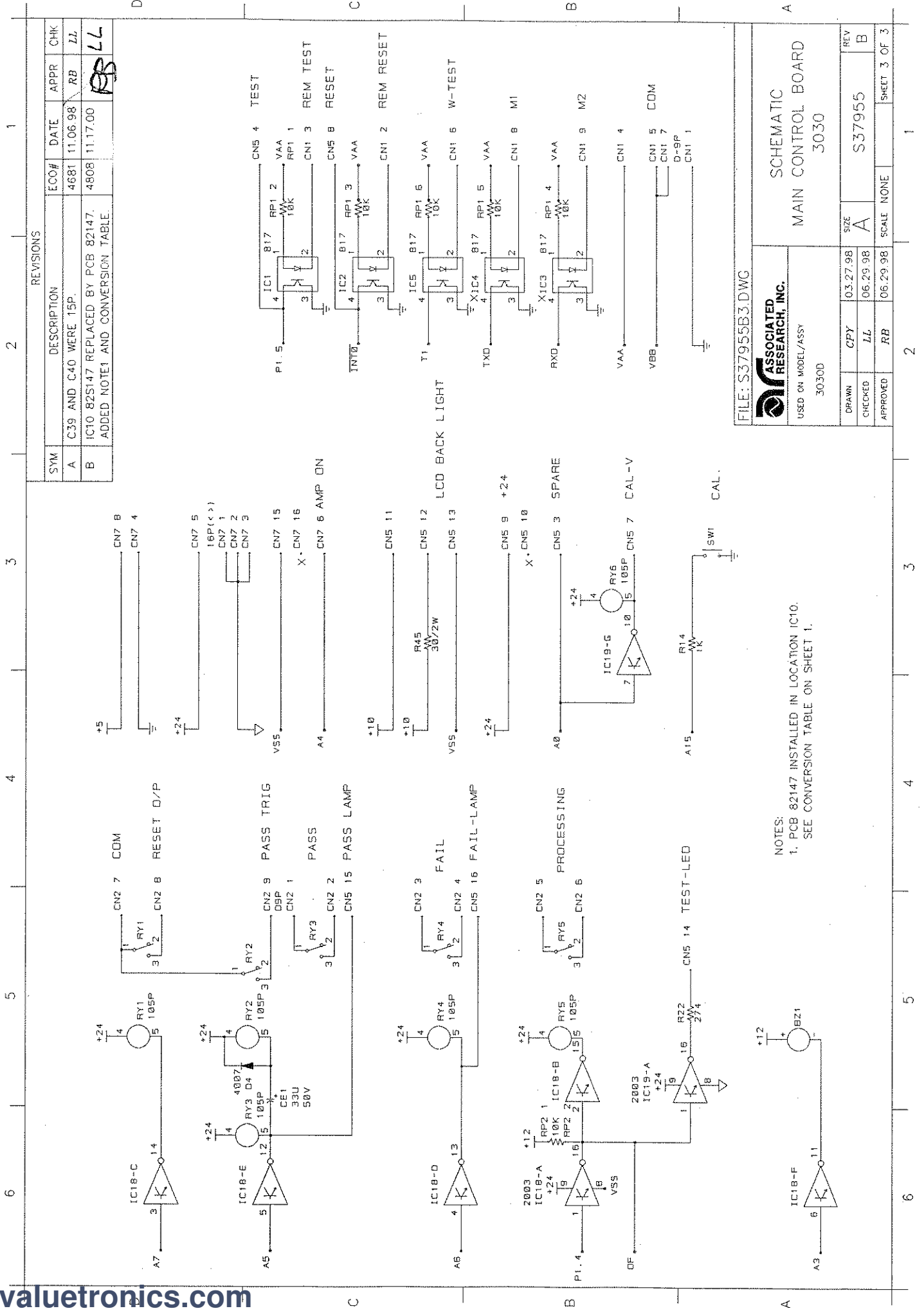

NOTES:  
 1. PCB 82147 INSTALLED IN LOCATION IC10.  
 SEE CONVERSION TABLE ON SHEET 1.

FILE: S37955B3.DWG



SCHEMATIC  
 MAIN CONTROL BOARD  
 3030

3030D

1 2 3 4 5 6

1 2 3 4 5 6

6 5 4 3 2 1

| SYM | DESCRIPTION | ECO# | DATE | APPR | CHK |
|-----|-------------|------|------|------|-----|
|     |             |      |      |      |     |

REVISIONS

| SYM | DESCRIPTION | ECO# | DATE | APPR | CHK |
|-----|-------------|------|------|------|-----|
|     |             |      |      |      |     |



6 5 4 3 2 1

REVISIONS

| SYM | DESCRIPTION   | ECO# | DATE     | APPR | CHK |
|-----|---|------|----------|------|-----|
| A   | CONT WAS PASS, ADDED 205D AND NOTE 1.   | 4635 | 12.06.96 | RB   | NLT |
| B   | ADDED 3505D AND 3565D.  | 4636 | 12.19.96 | RB   | NLT |
| C   | PCB WAS CKB-02, REMOVED 3560D. ADDED 3570D, CN1 5 WAS P1.6, CN1 6 WAS P1.7.                     | 4671 | 05.23.98 | LL   | NLT |
| D   | ADDED MODEL 3030D AND TABLE 1. DELETED: A10(R119), A11(R118), HV-LED, CONT LAMP NOTE 1, NOTES.. | -    | 06.29.98 | RB   | LL  |
| E   | ADDED MODEL 4500D. REVISED TABLE 1. REDRAWN.  | -    | 12.17.99 | RB   | LL  |

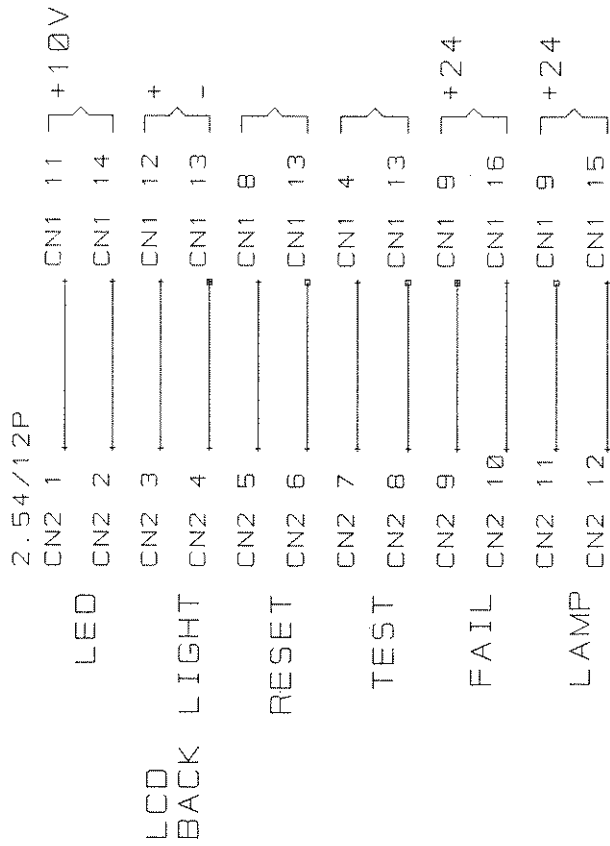
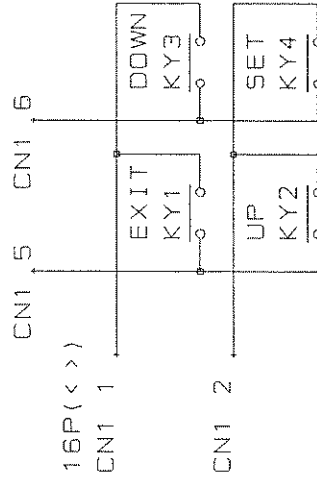

TABLE 1

| REFERENCE | MODEL     |           |            |
|-----------|-----------|-----------|------------|
|           | 205D      | 3030D     | 3500-70D   |
| CN1 1     | C4        | C4        | C4         |
| CN1 2     | C5        | C5        | C5         |
| CN1 4     | P1.5      | P1.5      | P1.5       |
| CN1 5     | P1.6      | P1.6      | A10 (R119) |
| CN1 6     | P1.7      | P1.7      | A11 (R118) |
| CN1 8     | INT0      | INT0      | INT0       |
| CN1 13    | G         | G         | G          |
| CN1 14    | HV-LED    | TEST-LED  | HV-LED     |
| CN1 15    | X         | PASS LAMP | CONT LAMP  |
| CN1 16    | FAIL LAMP | FAIL LAMP | FAIL LAMP  |



FILE: S37593E.DWG



USED ON MODEL/ASSY  
205D 3030D 3500-70D 4500D

SCHEMATIC  
PCB KEYPAD  
CKB-02A

|          |     |            |              |
|----------|-----|------------|--------------|
| DRAWN    | CPY | SIZE       | REV          |
| CHECKED  | NLT | A          | S37593       |
| APPROVED | RB  | SCALE NONE | SHEET 1 OF 1 |

6

6



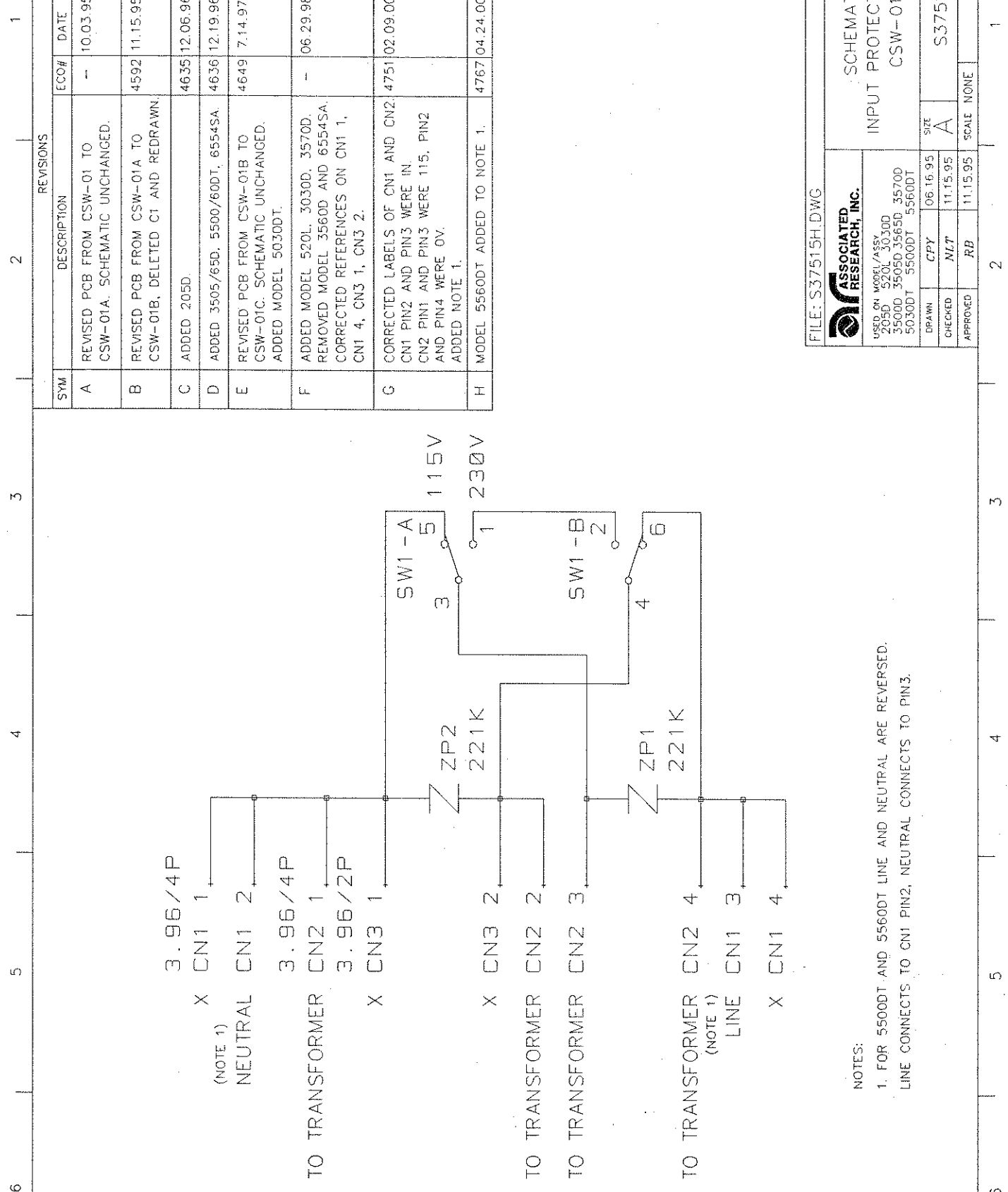

| SYM | DESCRIPTION  | ECO# | DATE     | APPR | CHK |
|-----|--|------|----------|------|-----|
| A   | REVISED PCB FROM CSW-01 TO CSW-01A. SCHEMATIC UNCHANGED.   | -    | 10.03.95 | RB   | NLT |
| B   | REVISED PCB FROM CSW-01A TO CSW-01B, DELETED C1 AND REDRAWN.   | 4592 | 11.15.95 | RB   | NLT |
| C   | ADDED 205D.  | 4635 | 12.06.96 | RB   | NLT |
| D   | ADDED 3505/65D, 5500/60DT, 6554SA.   | 4636 | 12.19.96 | RB   | NLT |
| E   | REVISED PCB FROM CSW-01B TO CSW-01C. SCHEMATIC UNCHANGED. ADDED MODEL 5030DT.  | 4649 | 7.14.97  | RB   | NLT |
| F   | ADDED MODEL 520L, 3030D, 3570D. REMOVED MODEL 3560D AND 6554SA. CORRECTED REFERENCES ON CN1 1, CN1 4, CN3 1, CN3 2.          | -    | 06.29.98 | RB   | LL  |
| G   | CORRECTED LABELS OF CN1 AND CN2. CN1 PIN2 AND PIN3 WERE IN. CN2 PIN1 AND PIN3 WERE 115, PIN2 AND PIN4 WERE OV. ADDED NOTE 1. | 4751 | 02.09.00 | RB   | LL  |
| H   | MODEL 5560DT ADDED TO NOTE 1.  | 4767 | 04.24.00 | RB   | LL  |

FILE: S37515H.DWG



|  |            |
|--|------------|
| USED ON MODEL/ASSY:<br>205D<br>520L 3030D<br>3500D 3505D 3565D 3570D<br>5030DT 5500DT 5560DT |            |
| DRAWN  | CPY        |
| CHECKED  | NLT        |
| APPROVED   | RB         |
| DATE   | SIZE       |
| 06.16.95   | A          |
| 11.15.95   | S37515     |
| 11.15.95   | SCALE NONE |
| SHEET 1 OF 1   |            |

SCHEMATIC  
INPUT PROTECTION PCB  
CSW-01C

NOTES:  
1. FOR 5500DT AND 5560DT LINE AND NEUTRAL ARE REVERSED.  
LINE CONNECTS TO CN1 PIN2, NEUTRAL CONNECTS TO PIN3.

6 5 4 3 2 1

REVISIONS

| SYM | DESCRIPTION              | ECO# | DATE     | APPR      | CHK       |
|-----|--------------------------|------|----------|-----------|-----------|
| A   | CE1 AND CE2 WERE 56000U. | 4681 | 11.06.98 | <i>RL</i> | <i>LL</i> |

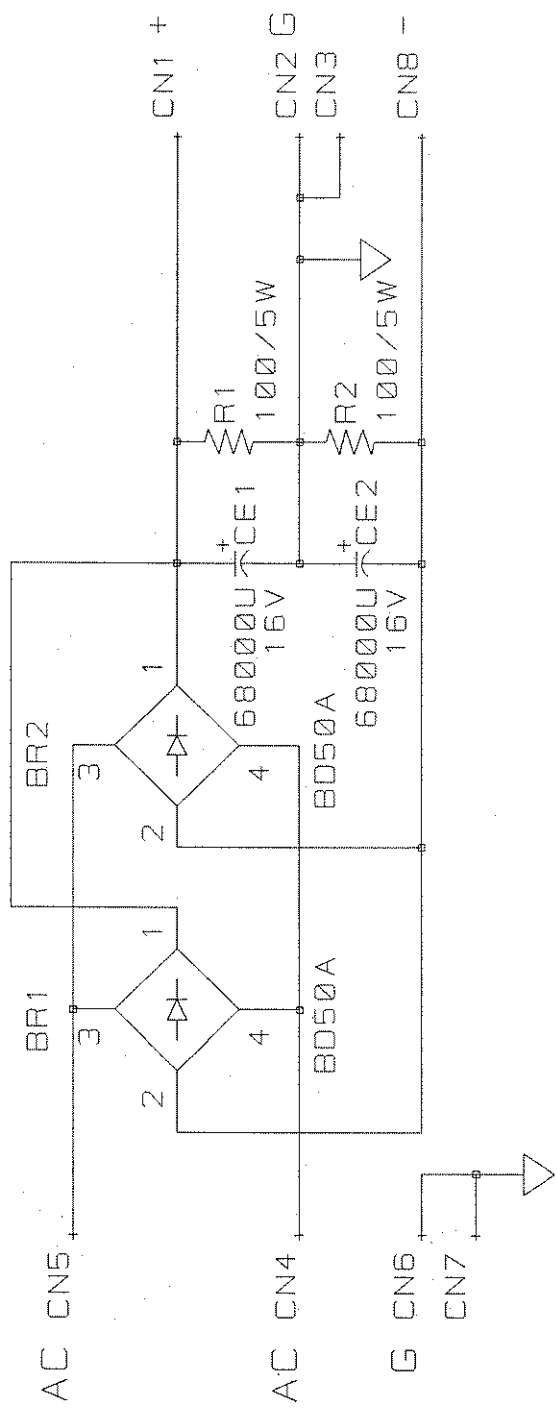

FILE: S37957A.DWG



USED ON MODEL/ASSY

30300

SCHEMATIC  
RECTIFIER BOARD  
REC-18A

| DRAWN     | CPY       | SIZE | REV          |
|-----------|-----------|------|--------------|
| <i>LL</i> | <i>LL</i> | A    | A            |
| APPROVED  | SCALE     | NONE | SHEET 1 OF 1 |
| <i>RB</i> |           |      |              |

6 5 4 3 2 1

| REVISIONS |             |      |      |
|-----------|-------------|------|------|
| SYM       | DESCRIPTION | ECO# | DATE |
|           |             |      |      |
|           |             |      |      |

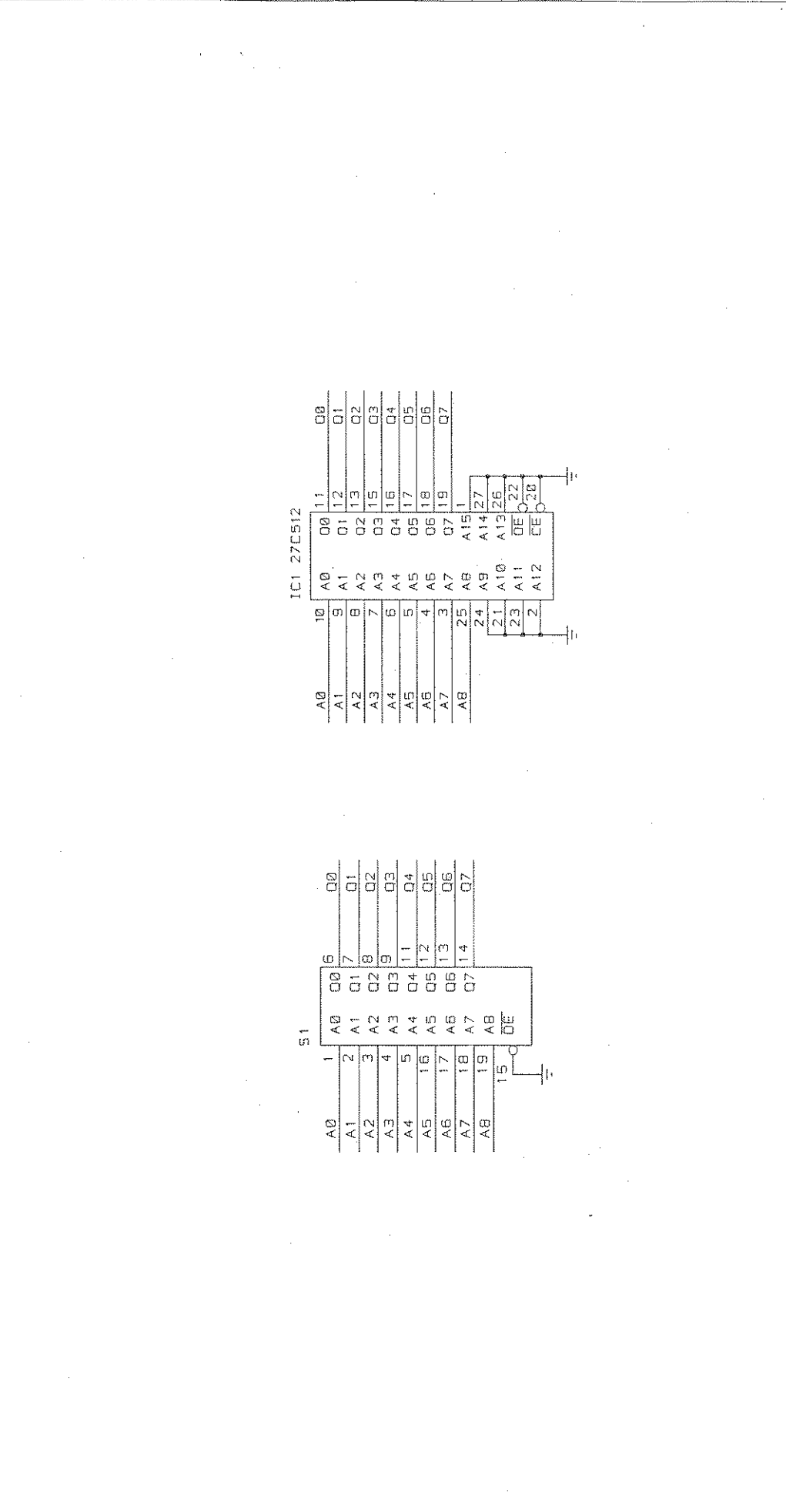

FILE: S38220.DWG

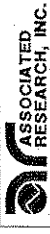

USED ON MODEL/ASSY  
35xxD, 3030D, 55xxDT, 50300T

SCHEMATIC  
ROM CONVERSION BOARD  
82147

| DRAWN    | COPY | SIZE | REV |
|----------|------|------|-----|
|          |      |      |     |
| CHECKED  |      |      |     |
| APPROVED |      |      |     |

| SCALE | NONE | SHEET | 1 OF 1 |
|-------|------|-------|--------|
|       |      |       |        |

6 5 4 3 2 1