

Anritsu

Site Master™
S810A, S818A
Antenna and
Coax/Waveguide Analyzer

User's Guide



**Hand-Held Tester For Antennas, Transmission Lines
And Other RF Components**

Color Cover P/N: 00986-00019

WARRANTY

The ANRITSU product(s) listed on the title page is (are) warranted against defects in materials and workmanship for one year from the date of shipment.

ANRITSU's obligation covers repairing or replacing products which prove to be defective during the warranty period. Buyers shall prepay transportation charges for equipment returned to ANRITSU for warranty repairs. Obligation is limited to the original purchaser. ANRITSU is not liable for consequential damages.

LIMITATION OF WARRANTY

The foregoing warranty does not apply to ANRITSU connectors that have failed due to normal wear. Also, the warranty does not apply to defects resulting from improper or inadequate maintenance by the Buyer, unauthorized modification or misuse, or operation outside the environmental specifications of the product. No other warranty is expressed or implied, and the remedies provided herein are the Buyer's sole and exclusive remedies.

TRADEMARK ACKNOWLEDGEMENTS

MS-DOS, Windows, Windows for Workgroups, Windows NT, and Windows 95 are registered trademarks of the Microsoft Corporation. **Site Master** and **Cable Mate** are trademarks of ANRITSU Company.

NOTICE

ANRITSU Company has prepared this manual for use by ANRITSU Company personnel and customers as a guide for the proper installation, operation and maintenance of ANRITSU Company equipment and computer programs. The drawings, specifications, and information contained herein are the property of ANRITSU Company, and any unauthorized use or disclosure of these drawings, specifications, and information is prohibited; they shall not be reproduced, copied, or used in whole or in part as the basis for manufacture or sale of the equipment or software programs without the prior written consent of ANRITSU Company.

MANUAL ERRATA

MANUAL:

Title: Site Master S810A, S818A Antenna and Coax/
Waveguide Analyzer User's Guide

Part Number: 10580-00014

Rev. Ltr/Date: A / November 1997



ERRATA PACKET

Part Number: 10901-00133

INSTRUCTIONS

1. Make the manual change listed below.

ERRATA 1, December 1997

1. Page 1-3

Delete the following items from the Optional Accessories list:

- Armoured Test Port Extension Cable, 3.0 meter, N(m) to N(f), Part No. 15NNF50-3.0B
- Armoured Test Port Extension Cable, 5.0 meter, N(m) to N(f), Part No. 15NNF50-5.0B

DECLARATION OF CONFORMITY

Manufacturer's Name: ANRITSU COMPANY

Manufacturer's Address: Microwave Measurements Division
490 Jarvis Drive
Morgan Hill, CA 95037-2809
USA

declares that the product specified below:

Product Name: Site Master

Model Number: S810A, S818A

conforms to the requirement of:

EMC Directive 89/336/EEC as amended by Council Directive 92/31/EEC & 93/68/EEC
Low Voltage Directive 73/23/EEC as amended by Council directive 93/68/EEC

Electromagnetic Interference:

Emissions: CISPR 11:1990/EN55011:1991 Group 1 Class A

Immunity: IEC 1000-4-2:1995/prEN50082-1:1995 - 4kV CD, 8kV AD
IEC 1000-4-3:1993/ENV50140:1994 - 3V/m
IEC 1000-4-4:1995/prEN50082-1:1995 - 0.5kV SL, 1kV PL

Electrical Safety Requirement:

Product Safety: The Product Complies when used with Company supplied Power
Supply (tested to EN 60950)

Morgan Hill, CA



Manager of Corporate Quality

17-OCT-97
Date

European Contact: For Anritsu product EMC & LVD information, contact Anritsu LTD, Rutherford Close,
Stevenage Herts, SG1 2EF UK, (FAX 44-1438-740202)

Table of Contents

General Information	1-1
Introduction.	1-1
Description	1-1
Standard Accessories	1-2
Options	1-3
Optional Accessories	1-3
Performance Specifications	1-5
Operation	2-1
Introduction.	2-1
Control Descriptions	2-1
Test Panel.	2-1
Keypad	2-2
Soft Keys	2-6
Operating Procedures.	2-24
Making Common Function Selections	2-25
Applying Power	2-25
Performing a Calibration.	2-25
Setting Options	2-27
Setting Markers	2-28
Setting Scale/Limits.	2-28
Determining Remaining Battery Life	2-29
Making Frequency-Domain Measurements	2-30
Return Loss or SWR Measurement	2-30
Selecting a Frequency Range.	2-30
Performing a Calibration.	2-31
Making a Measurement	2-32
Scaling the Display	2-32
Adjusting Markers	2-33
Adjusting a Limit	2-33
Saving a Setup.	2-34
Recalling a Setup	2-34
Storing a Display	2-34
Recalling a Display	2-35

Coax/Waveguide Loss Measurement . . .	2-35
Selecting a Frequency Range.	2-35
Performing a Calibration.	2-36
Making a Measurement	2-37
Scaling the Display	2-38
Adjusting Markers	2-38
Adjusting a Limit	2-39
Saving a Setup.	2-39
Recalling a Setup	2-39
Storing a Display	2-40
Recalling a Display	2-40
Making Distance-Domain Measurements .	2-41
Selecting a Frequency Range.	2-41
Performing a Calibration.	2-43
Performing a DTF Measurement	2-44
Scaling the Display	2-45
Adjusting Markers	2-45
Adjusting a Limit	2-46
Saving a Setup.	2-47
Recalling a Setup	2-47
Storing a Display	2-47
Recalling a Display	2-48
Making Power Measurements	2-48
Entering Power Monitor Mode	2-48
Zeroing the Power Monitor	2-48
Measuring High Input Power Levels	2-48
Displaying Power in dBm and Watts	2-49
Displaying Relative Power	2-49
Printing.	2-50
Printer Switch Settings	2-50
Printing a Screen	2-51
Symbols	2-52
Self Test	2-52
Error Codes	2-52
Self Test Errors	2-52
Range Errors	2-52
Replacing the Battery	2-52
Using the Soft Carrying Case.	2-57

Software Tools Program	3-1
Description	3-1
Requirements	3-1
Communication Port Setting.	3-2
Changing COM Port Settings–Windows 3.1	3-2
Changing COM Port Settings–Windows 95	3-4
Software Installation	3-5
Plot Capture.	3-6
Capture multiple to database	3-7
Capture multiple traces to PC screen.	3-8
Single trace capture	3-8
Program Operation.	3-9
Fault Location Software	3-10
Smith Chart Software.	3-10
Saving a Plot as a Windows Metafile.	3-11
Saving Data to a Spreadsheet.	3-11
Saving Data to a Data Base	3-12
“Drag-n-Drop”	3-12
Printing.	3-12
Appendix A Reference Data	A-1
Description	A-1

How to Use this Manual

The operation of the **Site Master**™ is straightforward and intuitive. However, you may find it helpful to review the operation of the keys and menus prior to first-time use.

Descriptions of the keys and menus, along with measurement procedures, are provided in Chapter 2.

First-time users and maintenance supervisors will benefit from perusing the material in Chapter 1. This chapter describes the instrument and provides listings of options and performance specifications.

Please Recycle

This product contains a rechargeable nickel-cadmium battery. Spent nickel-cadmium batteries are valuable resources, do not throw them away. Arrange for proper return for recycling in your locality. If you do not have access to proper disposal methods, return the battery to your ANRITSU service center. Service centers will dispose of the unit at no charge. ANRITSU service centers are listed in Table 2-4 (page 2-58).



NiCd

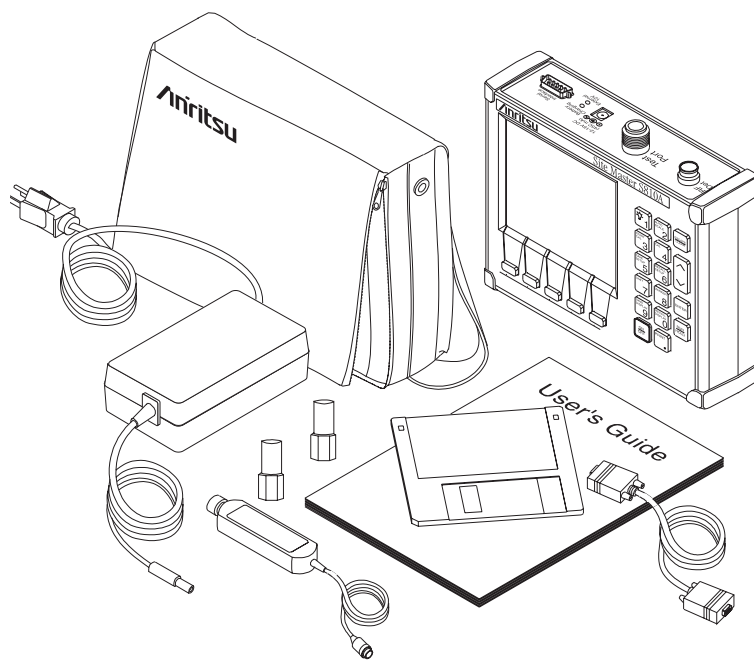

Figure 1-1. Site Master System

1 - 0

Chapter 1

General Information

Introduction

This chapter provides description, specification, and optional accessories for the **Site Master** Series instruments. This series has two members, as shown below. Throughout this manual, the term **Site Master** will refer to the series; whereas, the terms Site Master **S810A** and **S818A** will refer to the applicable individual models.

Model	Frequency Range
S810A	3.3 to 10.5 GHz
S818A	3.3 to 18.0 GHz

Description

The **Site Master** (Figure 1-1) is a hand held SWR/RL(standing wave ratio/return loss) and Distance-To-Fault measurement instrument that includes a built-in synthesized signal source and an optional power monitor. It uses a keypad to enter data and a liquid crystal display (LCD) to provide a graphical indication of SWR or RL over the selected frequency range. The **Site Master** has a built-in distance-to-fault capability. The **Site Master** is capable of up to two hours of continuous operation from a fully charged internal battery. It can also be operated from a 12.5 dc source (which will also simultaneously charge the battery). Built-in energy conservation features can be used to extend battery life over an eight-hour work day.

The **Site Master** is designed for measuring SWR, return loss, or coax/waveguide insertion loss and locating faulty RF components in antenna systems. Power monitoring capability is available as an option. The displayed trace can be scaled and/or enhanced with settable frequency markers and/or a limit line. A menu option provides for an audible



“beep” when the limit value is exceeded. To permit use in low-light environments, the LCD can be back lit using a front panel key.

Standard Accessories

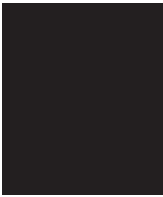

A PC based software program (called Software Tools) provides an on-line database record for storing measurement data. **Site Master** Software Tools can also convert the **Site Master** display to a Microsoft Windows 95 or Windows 3.x graphic. Measurements stored in the **Site Master** internal memory are down-loaded to the PC using the included serial cable. This null-modem serial cable connects between the Serial Interface connector on the **Site Master** and a Com Port on a DOS/Windows-based PC. Once stored, the graphic trace can then be displayed, scaled, and/or enhanced with markers and limit lines. Historical graphs can be overlaid with current data by using the PC's mouse in “drag-n-drop” fashion. The underlying data can be extracted and used in spreadsheets or for other analytical tasks.

The Software Tools program also performs DTF (Distance To Fault) or Fault Location and Smith Chart by clicking on the appropriate icon.

The following items are supplied with the basic hardware.

- Soft Carrying Case
- AC-DC Adapter
- Automotive Cigarette Lighter 12 Volt DC Adapter
- 3 1/2-inch floppy disk containing the Software Tools program. This program contains Fault Location (DTF) and Smith Chart functions
- Serial Interface Cable (Null Modem Type)
- One year Warranty (includes battery, firmware, and software)
- User's Guide

Options

- Option 5 — Add RF Wattmeter Power Monitor

Optional Accessories

- Precision N (m) Short/Open, Part No. 22N50
- Precision N (f) Short/Open, Part No. 22NF50
- Precision N (m) Load, 40 dB, Part No. 28N50-2
- Precision N (f) Load, 40 dB, Part No. 28NF50-2
- Adapter, Precision N (m) to N (m), Part No. 34NN50A
- Adapter, Precision N (f) to N (f), Part No. 34NFNF50
- Armoured Test Port Extension Cable, 1.5 meter, N (m) to N (f), Part No. 15NNF50-1.5B
- ~~Armoured Test Port Extension Cable, 3.0 meter, N (m) to N (f), Part No. 15NNF50-3.0B~~
- ~~Armoured Test Port Extension Cable, 5.0 meter, N (m) to N (f), Part No. 15NNF50-5.0B~~
- Precision Universal Waveguide Calibration Components, see Table A-1
- Precision Coaxial-to-Universal Waveguide Adapters, see Table A-2
- RF Detector, 10 MHz to 20 GHz, N(m) input connector, 50 Ohms, Part No. 560-7N50B
- Transit Case for Site Master, Part No. 760-213



Chapter 1 General Information

- HP Deskjet 340 Printer, Part No. 2000-766
- Serial-to-Parallel Converter Cable (use with the HP 340 Printer), Part No. 2000-753
- Seiko DPU-411 Thermal Printer, Part No. 2000-754 (U.S.) or 2000-761 (Europe)
- Serial Interface Cable (use with the DPU-411 Printer), Part No. 2000-756
- Thermal Paper (use with the DPU-411 Printer), Part No. 2000-755

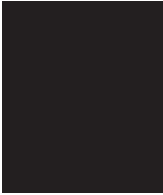

Performance Specifications

Performance specifications are provided in Table 1-1.

Table 1-1. Performance Specifications (1 of 2)

Specifications are valid when the unit is calibrated at ambient temperature after a 5 minute warmup.

<u>Description</u>	<u>Value</u>
Frequency Range:	
Site Master S810A	3.3 to 10.5 GHz
Site Master S818A	3.3 to 18.0 GHz
Frequency Accuracy	75 parts per million @ 25°C*
Frequency Resolution	1 MHz
SWR:	
Range	1.00 to 65.00
Resolution	0.01
Return Loss:	
Range	0.0 to 54.00 dB
Resolution	0.01 dB
Coax/Waveguide Insertion Loss:	
Range	0.0 to 54.00 dB
Resolution	0.01 dB
**Distance-To-Fault (DTF):	
Range	0 to (Resolution x 128)
Coax:	
Resolution (in meters)	$\frac{(15 \times 10^8)(V_f)}{\Delta\text{Frequency}}$
(Rectangular Windowing)	<i>Where V_f is the cable's relative propagation velocity.</i>
Waveguide:	
Resolution (in meters)	$\frac{(15 \times 10^8)(\sqrt{1 - (f_c/f_1)^2})}{\Delta\text{Frequency}}$
(Rectangular Windowing)	<i>Where f_c is the waveguide's cut-off frequency and f_1 is the start frequency of the sweep.</i>



Chapter 1 General Information

Table 1-1. Performance Specifications (2 of 2)

Wattmeter Power Monitor:	
Range	-80.0 to +80 dBm <i>or</i> 10.0 pW to 100.0 KW
Offset Range	0 to +60.0 dB
Resolution	0.1 dB <i>or</i> 0.1 xW
Test Port, Type N	50 Ohms
***Immunity to Interfering signals up to the level of	-15 dBm
Maximum Input (Damage Level):	
Test Port, Type N	+22 dBm
RF Detector	+20 dBm
Measurement Accuracy: Measurement accuracy depends on calibration components. Precision calibration components have a directivity of 40 dB.	
Temperature:	
Storage	-20° C to 75° C
Operation	0° C to 50° C
Weight:	3.0 pounds
Size:	8x7x2¼ inches

* ± 2 ppm/ Δ° C from 25°C

** Fault location is accomplished by inverse Fourier Transformation of data taken with the **Site Master**. Resolution and maximum range depend on the number of frequency data points, frequency sweep range and relative propagation velocity of the cable or group velocity of the waveguide being tested.

*** Immunity measurement is made in CW mode with incoming interfering signal exactly at the same frequency (worst case situation). Typical immunity is better when swept frequency is used.



This page is intentionally blank.

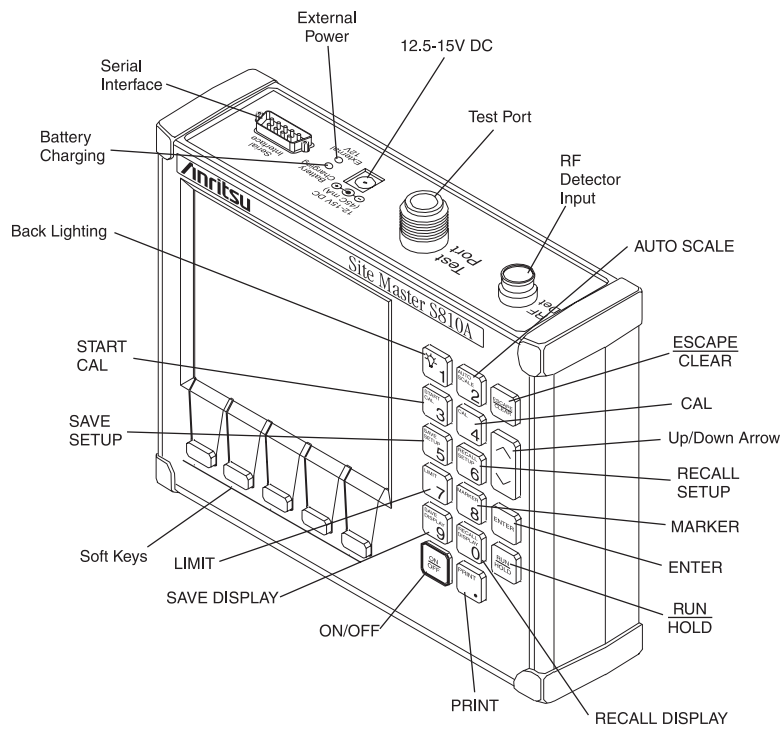

Figure 2-1. Site Master Controls and Connectors

2 - 0

Chapter 2

Operation

Introduction

This chapter provides a description of each control and describes how to calibrate the **Site Master** and make a measurement.

Control Descriptions

Control descriptions are given below; the test panel controls and connectors are listed first. The keypad controls follow and are listed alphabetically. Then, the soft keys and menu structure are described using Figure 2-3 (page 2-8).



Test Panel

12.5-15VDC (600 mA) Provides input for battery charging the unit. Input is 12.5 to 15 Vdc @ 600 mA.

Battery Charging Indicator light to show that the battery is being charged. (Indicator automatically shuts off when the battery is fully charged.)

External Power Indicator light to show that the **Site Master** is being powered by the external charging unit.

Serial Interface Provides an RS232 DB9 interface with a Com Port on a personal computer (for use with the ANRITSU Software Tools program). Also provides an interface to a HP Deskjet 340 printer or a Seiko DPU-411 Thermal printer.

Test Port Provides RF output, 50Ω impedance.

RF Det Provides RF detector input for the Power Monitor.

2 - 1

Keypad



Turns the liquid crystal display (LCD) back-lighting ON or OFF. (Leaving back lighting off conserves battery power.)

AUTO SCALE

Automatically scales the display for optimum resolution.

CAL

Displays the calibration configuration—the type of calibration, the frequency range, the valid temperature range of the calibration, and the current temperature.

ENTER

Implements certain menu and key selections.

ESCAPE CLEAR

Exits the present operation and/or clears the display. If a parameter is being edited, pressing this key will clear the value currently being entered and restore the last valid entry. Pressing this key again will close the parameter. During normal sweeping, pressing this key will move up one menu level.

LIMIT

Calls up the Scale Menu, described on page 2-12.

MARKER

Calls up the Markers Menu, described on page 2-21.

ON OFF

Turns the **Site Master** on or off. When turned on, the system state at the last turn-off is restored. If the **ESCAPE/CLEAR** key is held down, the factory preset state is restored.

PRINT

Prints the current display to the selected printer.

RECALL DISPLAY

Recalls a previously saved trace from memory location 1 through 70. When the key is pressed, “Recall display:” appears on the display. Select an appropriate number from the keypad and press the **ENTER** key to implement.

RECALL SETUP

Recalls a previously saved setup from memory location 0 through 6. When the key is pressed, “Recall Setup:” appears on the display. Select an appropriate

number using the Up/Down Arrow key and press the ENTER key to implement. Setup 0 recalls the factory preset state.

**RUN
HOLD**

When in the Hold mode, this key starts the **Site Master** sweeping and provides a Single Sweep Mode trigger; when in the Run mode, it pauses the sweep. When in the Hold mode, the hold symbol (Table 2-1, page 2-54) appears on the left side of the LCD. (HOLD conserves considerable battery power.)

**SAVE
DISPLAY**

Saves the displayed trace to 1 of 70 internal non-volatile memory locations. When the key is pressed, the next available empty memory location appears on the display (i.e. "Save display 3"). Press ENTER to save to the current empty memory location or select an appropriate number from the keyboard or use the Up/Down Arrow key and press the ENTER key to implement.

To erase saved displays select 0 and press ENTER. Individual displays may be selected and erased by entering the display number and pressing ENTER. Selecting display 0 will erase all saved displays.

CAUTION: *The selected memory location will be overwritten by the SAVE DISPLAY operation. No warning is given.*
When the Site Master is cycled on/off, the memory location increment resets to the lowest memory location (1).

**SAVE
SETUP**

Saves the current system setup to 1 of 6 internal non-volatile memory locations. When the key is pressed, "Save Setup:" appears on the display. Select an appropriate number using the Up/Down Arrow key and press the ENTER key to implement.

CAUTION: *The selected memory location will be overwritten by the SAVE SETUP operation. No warning is given.*

**START
CAL**

Opens a calibration menu. Use the Up/Down Arrow key and ENTER key to select either COAX or WAVEGUIDE calibration. Then select the desired setup configuration from the next menu screen.

For Coax Calibration, follow the text in the message area that instructs you to do the following:

- Connect OPEN, Press ENTER.
The **Site Master** will measure the calibration “open” that you must attach to the end of the test port .
- Connect SHORT, Press ENTER
The **Site Master** will measure the calibration “short” that you must attach to the end of the test port.
- Connect LOAD, Press ENTER
The **Site Master** then measures the 50Ω termination (load) that you must attach to the end of the test port.

For Waveguide Calibration, follow the text in the message area that instructs you to do the following:

- Connect SHORT 1, Press ENTER
The **Site Master** will measure the calibration “short” that you must attach to the end of the test port.
- Connect SHORT 2, Press ENTER
The **Site Master** will measure the calibration “short” that you must attach to the end of the test port.

- ❑ Connect LOAD, Press ENTER

The **Site Master** will measure the 50Ω termination (load) that you must attach to the end of the test port.

NOTE:

The combined measurements of an open, a short, and a known-impedance load in coax calibration and of known-offset shorts and known-impedance load in waveguide calibration normalizes the measurement system, to account for uncertainties introduced by measurement-system components (e.g., cables, connectors, etc.).

Up/Down Arrow Key Increments or decrements a parameter value.

NOTE:

At turn on, before any other keys are pressed, the Up/Down Arrow Key may be used to adjust display contrast.



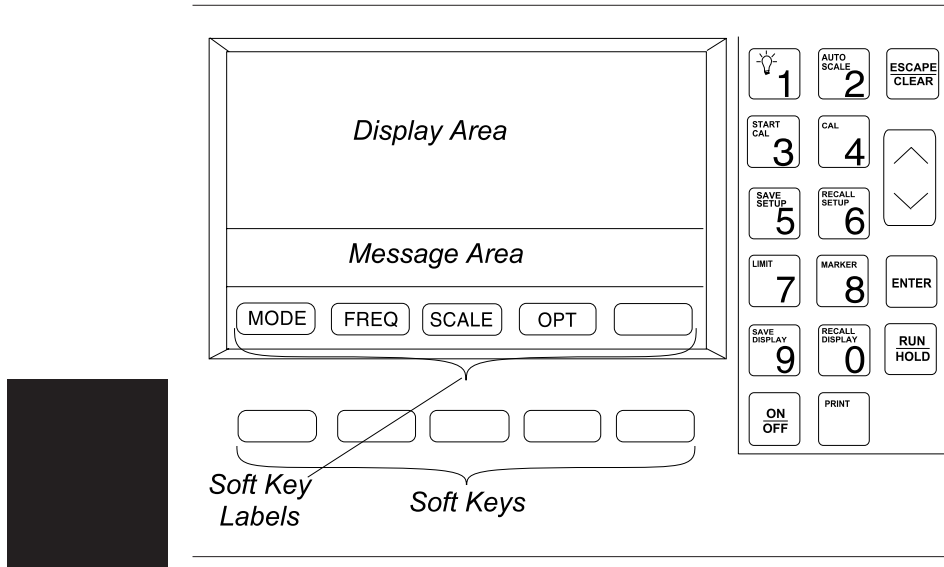
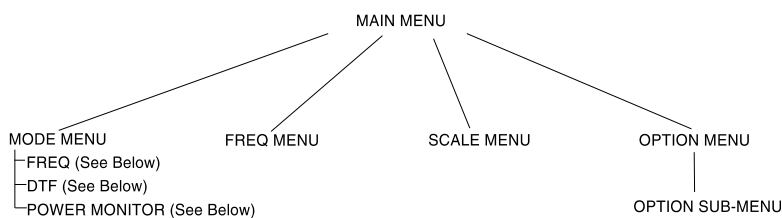

Figure 2-2. Site Master Front Panel Display Layout

Soft Keys

Each of the soft keys has a corresponding soft key label area on the display. The label identifies the function of the soft key for the current menu selection.

Figure 2-3, on the following page, shows the menu structure, the soft key labels for each menu selection, and the page where a description of the menu can be found.



MODE	MENU TITLE	SOFT KEY LABELS					PAGE
FREQ (Default Mode)	MAIN MENU	MODE	FREQ	SCALE	OPT		2-8
	FREQUENCY MENU	F1	F2			MAIN	2-11
	SCALE MENU	TOP	BOTTOM	LIMIT		MAIN	2-12
	OPTION MENU	B1	B2	B3	B4	MORE	2-13
	OPTION SUB-MENU	B5	B6	B7		MAIN	2-14
DTF	MAIN MENU	MODE	DIST	SCALE	OPT		2-9
	DISTANCE MENU	D1	D2	DTF AID		MORE	2-15
	DISTANCE SUB-MENU 1	LOSS	PROP V	CABLE	WINDW	MAIN	2-16
	DISTANCE SUB-MENU 2	LOSS	CUTOFF	WAVE G	WINDW	MAIN	2-17
	SCALE MENU	TOP	BOTTOM	LIMIT		MAIN	2-12
	OPTION MENU	B1	B2	B3	B4	MORE	2-13
	OPTION SUB-MENU	B5	B6	B7		MAIN	2-14
POWER MONITOR	MAIN MENU	UNITS	REL	OFFSET	ZERO	MAIN	2-10

Figure 2-3. Site Master Menu Structure

Main Menu At turn on, the Main Menu soft keys, below, are displayed, and the Marker status is shown in the message area.



These soft keys provide the following menu selections:

- ❑ **MODE** — Selects the type of measurement. Use the Up/Down Arrow key and ENTER key to select the type of measurement in the FREQ, DTF, and POWER MONITOR measurement modes.
- ❑ **FREQ** — Selects the Frequency Menu, described on page 2-11.
- ❑ **SCALE** — Selects the Scale Menu, described on page 2-12.
- ❑ **OPT** — Selects the Option Menu, described on page 2-13.



DTF Main Menu When the DTF measurement mode is selected, the Main Menu soft keys, below, are displayed, and the Marker status is shown in the message area.



These soft keys provide the following menu selections:

- ❑ **MODE** — Selects the type of measurement. Use the Up/Down Arrow key and ENTER key to select the type of measurement in the **FREQ**, **DTF**, and **POWER MONITOR** measurement modes.
- ❑ **DIST** — Selects the Distance Menu, described on page 2-15.
- ❑ **SCALE** — Selects the Scale Menu, described on page 2-12.
- ❑ **OPT** — Selects the Option Menu, described on page 2-13.



Power Monitor Main Menu When the Power Monitor measurement mode is selected, the Main Menu soft keys, below, are displayed, and the units, relative, offset, and zero adjust status are shown in the message area.



- ❑ UNITS — Toggles between dBm and Watts.
- ❑ REL — Turns relative mode OFF, if currently ON. If relative mode is currently OFF, turns it ON and causes the power level to be measured and saved as the base level. Subsequent measurements are then displayed relative to this saved value. With units of dBm, relative mode displays dB_r; with units of Watts, relative mode displays % (percent).
- ❑ OFFSET — Turns Offset OFF, if currently ON. If Offset is currently OFF, turns it ON and opens the Offset parameter for data entry. Press ENTER when data entry is complete. Offset is the attenuation (in dB) inserted in the line between the DUT and the RF detector. The attenuation is added to the measured input level prior to display.
- ❑ ZERO — Turns Zero OFF, if currently ON. If Zero is currently OFF, turns it ON and initiates collection of a series of power level samples, which are averaged and saved. This saved value is then subtracted from subsequent measurements prior to display.
- ❑ MAIN — Returns to the Main Menu.



Frequency Menu (FREQ) Provides for setting sweep frequency end-points. Selected frequency values may be changed using the keypad or Up/Down Arrow key. All frequency entries are in GHz.

Choosing FREQ causes the soft keys, below, to be displayed and the corresponding values to be shown in the message area.



- ❑ F1 — Opens the F1 parameter for data entry. This is the start value for the frequency sweep. Press ENTER when data entry is complete.
- ❑ F2 — Opens the F2 parameter for data entry. This is the stop value for the frequency sweep. Press ENTER when data entry is complete.
- ❑ MAIN — Returns to the Main Menu.



Scale Menu (SCALE) Provides for changing the display scale. Selected values may be changed using the keypad or Up/Down Arrow key.

Choosing **SCALE** causes the soft keys, below, to be displayed and the corresponding values to be shown in the message area.

Pressing the **LIMIT** key on the keypad will also call up this menu.



- ❑ **TOP** — Opens the **TOP** parameter for data entry and provides for setting the top scale value. Press **ENTER** when data entry is complete.
- ❑ **BOTTOM** — Opens the **BOTTOM** parameter for data entry and provides for setting the bottom scale value. Press **ENTER** when data entry is complete.
- ❑ **LIMIT** — Turns Limit **OFF**, if currently **ON**. If Limit is currently **OFF**, turns it **ON** and opens the Limit parameter for data entry. Press **ENTER** when data entry is complete.
- ❑ **MAIN** — Returns to the Main Menu.

Option Menu (OPT)

Provides for selecting **Site Master** options.

Choosing OPT causes the soft keys, below, to be displayed and the corresponding values to be shown in the message area.

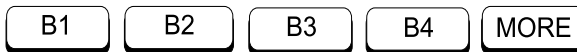

- ❑ B1 MATH — Opens a menu of trace math operation modes; OFF, TRACE - MEMORY. Use the Up/Down Arrow key and ENTER key to make a selection.
- ❑ B2 LIMIT BEEP ON/OFF — Toggles the limit beeping sound on or off. When on, the **Site Master** sounds a beep when the measured value is above the limit line.
- ❑ B3 KEYBD LOCK ON/OFF — Toggles the keyboard locking feature on or off. When on, the keyboard (except for the keys listed below) is locked to prevent inadvertent data entry.

When locked, pressing any key (except ON/OFF, RUN/HOLD, MORE, MAIN, OPT, and B3) will cause the lock-out symbol (Table 2-1, page 2-53) to display along the left edge of the LCD and an error beep to sound.
- ❑ B4 SINGLE SWP ON/ OFF — Toggles the single sweep function on or off. When on, the **Site Master** will have to be manually triggered using the RUN/HOLD key on the keypad for each sweep.
- ❑ MORE — Selects the Option Sub-Menu, described below.



**Option
Sub-Menu**

Provides for selecting additional **Site Master** options.

Choosing **MORE** causes the soft keys, below, to be displayed and the corresponding values to be shown in the message area.

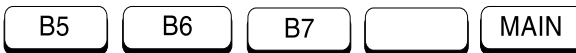

- B5 UNITS** — Toggles between **ENGLISH** and **METRIC** units.
- B6 PRINTER** — Displays a menu of supported printers—None, Seiko DPU-411, and HP Deskjet 340. Use the Up/Down Arrow key and **ENTER** key to make the selection.
- B7 CONTRAST** — Enables adjustment of the LCD contrast. Use the Up/Down Arrow key and **ENTER** key to set the contrast.
- MAIN** — Returns to the Main Menu.



Distance Menu (DIST)

Provides for setting Distance to Fault parameters. Selected distance values may be changed using the keypad or Up/Down Arrow key. Entry can be in feet or meters, depending on the setting of the B5 soft key in the Option Sub-Menu (page 2-15).

Choosing DIST causes the soft keys, below, to be displayed and the corresponding values to be shown in the message area.



- ❑ D1 — Opens the start distance (D1) parameter for data entry. This is the start value for the distance range. Press ENTER when data entry is complete.
- ❑ D2 — Opens the end distance (D2) parameter for data entry. This is the end value for the distance range. Press ENTER when data entry is complete.
- ❑ DTF AID — Provides interactive help to optimize DTF set up parameters. User is prompted for system parameter values of maximum distance, center frequency, cable or waveguide type, or propagation velocity or group velocity. Frequency parameters are then calculated to optimize both range and resolution.
- ❑ MORE — For coaxial cable, selects the Distance Sub-Menu 1, described on page 2-16. For waveguide, selects the Distance Sub-Menu 2, described on page 2-17.



NOTE: Refer to Appendix A for coaxial cable and waveguide technical data.

Distance Sub-Menu 1 Provides for setting the cable loss and relative propagation velocity of the coaxial cable. Selected values may be changed using the keypad or Up/Down Arrow key.

Choosing MORE causes the soft keys, below, to be displayed and the corresponding values to be shown in the message area.



- ❑ LOSS — Opens the Cable Loss parameter for data entry. Enter the loss per foot (or meter) for the type of transmission line being tested. Press ENTER when data entry is complete. (Range is 0.000 to 5.000 dB/m)
- ❑ PROP V (relative propagation velocity) — Opens the Propagation Velocity parameter for data entry. Enter the propagation velocity for the type of transmission line being tested. Press ENTER when data entry is complete. (Range is 0.010 to 1.000)
- ❑ CABLE — Opens a menu of common coaxial cables. Use the Up/Down Arrow key and ENTER key to make a selection. This feature is provided as a rapid means of setting both cable loss and propagation velocity.
- ❑ WINDW — Opens a menu of FFT windowing types for the DTF calculation. Use the Up/Down Arrow key and ENTER key to make a selection.
- ❑ MAIN — Returns to the Main Menu.

Distance Sub-Menu 2 Provides for setting waveguide loss and cutoff frequency of the waveguide. Selected values may be changed using the keypad or Up/Down Arrow key.

Choosing MORE causes the soft keys, below, to be displayed and the corresponding values to be shown in the message area.



- ❑ **LOSS** — Opens the Waveguide Loss parameter for data entry. Enter the loss per foot (or meter) for the type of waveguide being tested. Press ENTER when data entry is complete. (Range is 0.000 to 5.000 dB/m)
- ❑ **CUTOFF** — Opens the Cutoff Frequency parameter for data entry. Enter the cutoff frequency for the type of waveguide being tested. Press ENTER when data entry is complete.
- ❑ **WAVE G** — Opens a menu of common waveguides. Use the Up/Down Arrow key and ENTER key to make a selection. This feature is provided as a rapid means of setting both waveguide loss and cutoff frequency.
- ❑ **WINDW** — Opens a menu of FFT windowing types for DTF calculation. Use the Up/Down Arrow key and ENTER key to make a selection.
- ❑ **MAIN** — Returns to the Main Menu.



NOTE: Using Windowing

The theoretical requirement for inverse FFT is for the data to extend from zero frequency to infinity. Side lobes appear around a discontinuity due to the fact that the spectrum is cut off at a finite frequency. Windowing reduces the side lobes by smoothing out the sharp transitions at the beginning and end of the frequency sweep. As the side lobes are reduced the main lobe widens thereby reducing the resolution.

In situations where there may be a small discontinuity close to a large one, side lobe reduction Windowing should be used. When distance resolution is critical Windowing can be reduced. The types of Windowing in order of increasing side lobe reduction are: rectangular, nominal side lobe, low side lobe, minimum side lobe. Figures 2-4 thru 2-7, on pages 2-19 and 2-20, are examples of the types of Windowing.



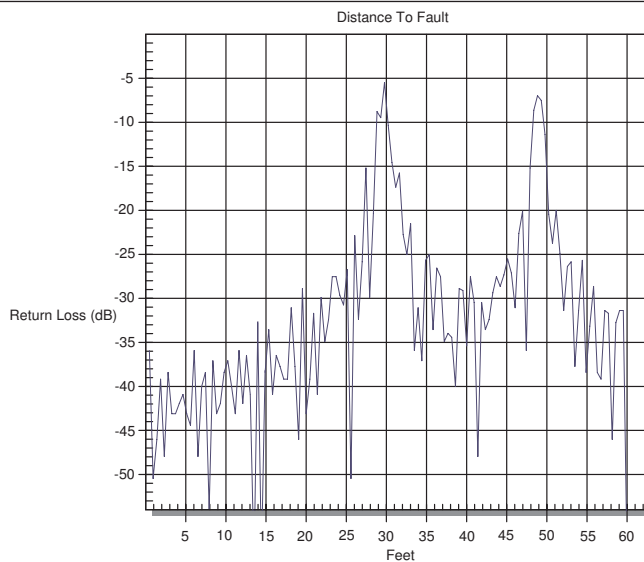

Figure 2-4. Rectangular Windowing Example

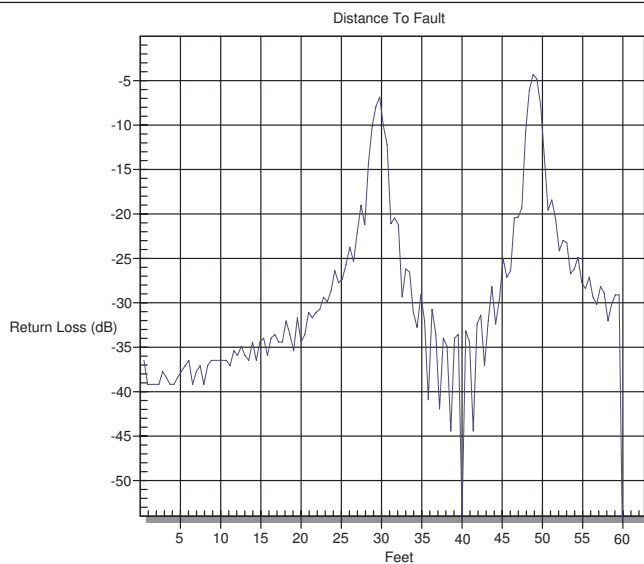

Figure 2-5. Nominal Side Lobe Windowing Example

Chapter 2 Operation

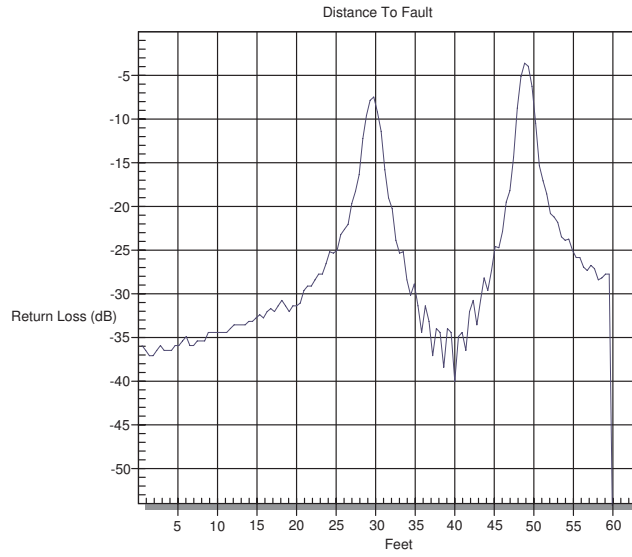

Figure 2-6. Low Side Lobe Windowing Example

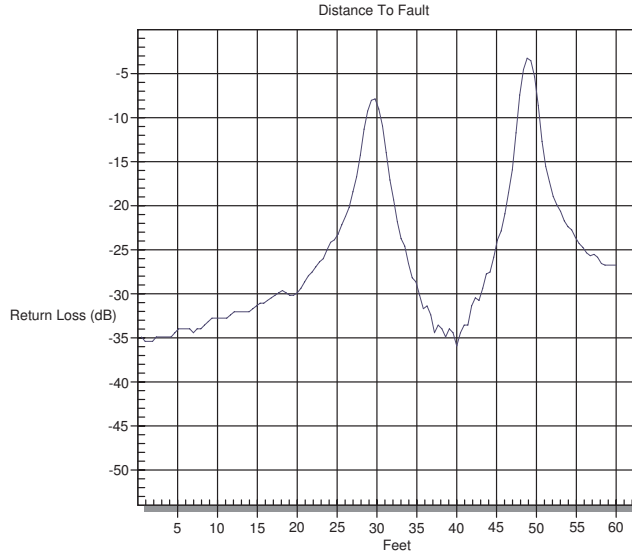
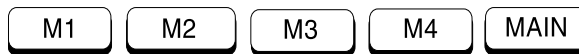

Figure 2-7. Minimum Side Lobe Windowing Example

**Markers
Menu
(MKRS)**

Provides for setting marker values. Selected frequency marker or distance marker values may be changed using the keypad or Up/Down Arrow key.

Pressing the MARKER key causes the soft keys, below, to be displayed and the corresponding values to be shown in the message area.



- ❑ M1 — Selects the M1 marker parameter, displaying either frequency or distance and the corresponding SWR, RL, or CWL and opens the Markers 2nd Level Menu, described on page 2-22.
- ❑ M2 — Selects the M2 marker parameter, displaying either frequency or distance and the corresponding SWR, RL, or CWL and opens the Markers 2nd Level Menu, described on page 2-22.
- ❑ M3 — Selects the M3 marker parameter, displaying either frequency or distance and the corresponding SWR, RL, or CWL and opens the Markers 2nd Level Menu, described on page 2-22.
- ❑ M4 — Selects the M4 marker parameter, displaying either frequency or distance and the corresponding SWR, RL, or CWL and opens the Markers 2nd Level Menu, described on page 2-22.
- ❑ MAIN — Returns to the Main Menu.



Markers Menu (2nd Level) Provides for turning the selected marker on and off and for setting marker values. Selected frequency marker and distance marker values can be changed using the keypad or Up/Down Arrow key.

Choosing M1 causes the soft keys, below, to be displayed and the corresponding values to be shown in the message area.



Choosing M2, M3, or M4 causes the soft keys, below, to be displayed and the corresponding values to be shown in the message area.



- ON/OFF — Turns the selected marker on or off.
- EDIT — Opens the selected marker parameter for data entry. Press ENTER when data entry is complete.
- DELTA — Displays delta SWR, RL, or CWL as well as delta frequency or distance for the selected marker with respect to the M1 marker.
- MORE — Selects the Markers 3rd Level Menu, described on page 2-23.
- BACK — Returns to Main Markers Menu.

Markers Menu (3rd Level) Provides selections for placing the selected marker at the frequency or distance with the maximum or minimum SWR, RL or CWL.

Choosing MORE causes the soft keys, below, to be displayed and the corresponding values to be shown in the message area.



- PEAK — Places the selected marker at the frequency or distance with the maximum SWR, RL, or CWL.
- VALLEY — Places the selected marker at the frequency or distance with the minimum SWR, RL, or CWL.
- BACK — Returns to the Markers 2nd Level Menu.
- MKRS — Returns to the Main Markers Menu.



Operating Procedures

Site Master operation can be divided into four functional areas: common functions, frequency domain, distance domain, and power monitor.

- Common functions are calibration, options, markers, and scale functions that are common to both frequency- and distance-domain measurements.
- Frequency domain measurements consist of Standing Wave Ratio (SWR), Return Loss (RL), and Coax/Waveguide Loss (CWL) made over a selectable frequency range. SWR and RL characterize the magnitude of reflections present in a device or transmission line. CWL measurements display the insertion loss of a coaxial or a waveguide transmission line over frequency.
- Distance domain measurements—commonly known as distance-to-fault (DTF)—are made over a selectable distance range. They include RL or SWR, but they also return information that can help locate discontinuities in a transmission line. CWL cannot be measured and Trace Math function is inoperative in the distance domain.
- Power monitor measurements can be either absolute or relative to some base power level, and can be displayed in either dBm or Watts. To allow measurement and display of power levels above the unit's specified input, the user may attenuate the signal and enter the corresponding offset. The offset is added to the measured input power prior to display. Finally, a zero adjust function is provided to allow subtraction of an inherent "noise" level prior to display.

CAUTION: The measurement system **MUST** be calibrated at the ambient temperature prior to making a measurement. You must calibrate when the setup frequency is changed. Calibrations and setups are not independent; they are tied together. The instrument can store up to six calibration/setup. When you recall a stored setup, perform a new calibration only if the test setup has been altered.

Making Common Function Selections

Common functions are calibration, options, markers, and scale functions that are common to both frequency- and distance-domain measurements.

Applying Power

- Step 1.** Turn the **Site Master** on using the ON/OFF key.
- Step 2.** Observe that the **Site Master** opening screen appears and that it performs a self test. The firmware version and model number are shown in the opening screen.

Performing a Calibration

- Step 3.** Perform a measurement calibration using the **START CAL** key. Select either **COAX** or **WAVEGUIDE** calibration type. Select the desired setup configuration from the following menu. Once setup is complete, select **START CALIBRATION** from the menu and press **ENTER**.

For COAX:

Follow the ensuing “Connect OPEN, Press ENTER,” “Connect SHORT, Press ENTER,” and “Connect LOAD, Press ENTER” instructions that appear in the message area. Connect the respective Open, Short, and Load components to the end of the

Chapter 2 Operation

Test Port Extension Cable (Figure 2-8) prior to pressing ENTER.

After each selection, the message “Measuring OPEN,” “Measuring SHORT,” or “Measuring LOAD” appears while the measurement is in progress.

For WAVEGUIDE:

Follow the ensuing “Connect SHORT 1, Press ENTER,” “Connect SHORT 2, Press ENTER,” and “Connect LOAD, Press ENTER” instructions that appear in the message area. Connect the respective Short 1, Short 2, and Load components to the end of the Test Port Extension Cable (Figure 2-8) prior to pressing ENTER.

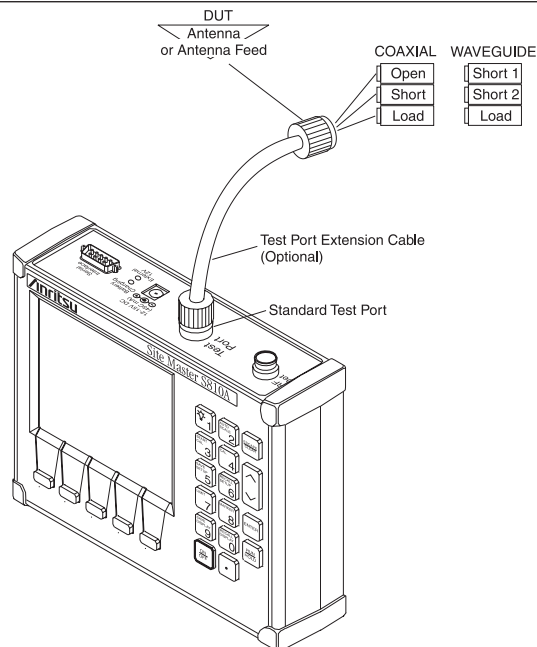

Figure 2-8. One-Port Measurement/Calibration Test Setup

After each selection, the message “Measuring SHORT 1,” “Measuring SHORT 2,” or “Measuring LOAD” appears while the measurement is in progress.

NOTES:

For best calibration results — compensation for all measurement system uncertainties — ensure that the Open/Short/Load (Short 1/Short 2/Load for waveguide) is at the end of the test port or optional extension cable; that is, at the same point that you will connect the antenna or device to be tested.

*For best results, use a phase stable Test Port Extension Cable (see Optional Accessories). If you use a typical laboratory cable to extend the **Site Master** test port to the device-under-test, cable bending subsequent to the Open/ Short/Load calibration will cause uncompensated phase reflections inside the cable. Thus, cables which are **NOT** phase stable may cause measurement errors that are more pronounced as the test frequency increases.*

For optimum calibration, ANRITSU recommends using precision calibration components.

Setting Options

- Step 4.** Press the **OPT** soft key, from the Main Menu (page 2-8).
- Step 5.** Accept or change the settings of the **B1** through **B7** options. Refer to pages 2-13 and 2-14 for a description of each option.

Setting Markers

- Step 6.** Press the **MARKER** key on the keypad.
- Step 7.** Accept or change the settings. To change, press the applicable **M1**, **M2**, **M3**, or **M4** soft key and either:
- Enter a numeric value from the keypad and press the **ENTER** key.
 - Or press the Up/Down Arrow key and press the **ENTER** key.



Setting Scale/Limits

- Step 8.** Press the **LIMIT** key on the keypad or the **SCALE** soft key, from the Main Menu.
- Step 9.** Accept or change the settings. To change, press the applicable **TOP**, **BOTTOM**, or **LIMIT** soft key and either:
- Enter a numeric value from the keypad and press the **ENTER** key.
 - Or press the Up/Down Arrow key and press the **ENTER** key.

Determining Remaining Battery Life

When the AC-DC adapter is disengaged from the Site Master, a battery indicator symbol is continuously displayed at the top-right corner of the display (Figure 2-9). A totally black bar indicates a fully charged battery.

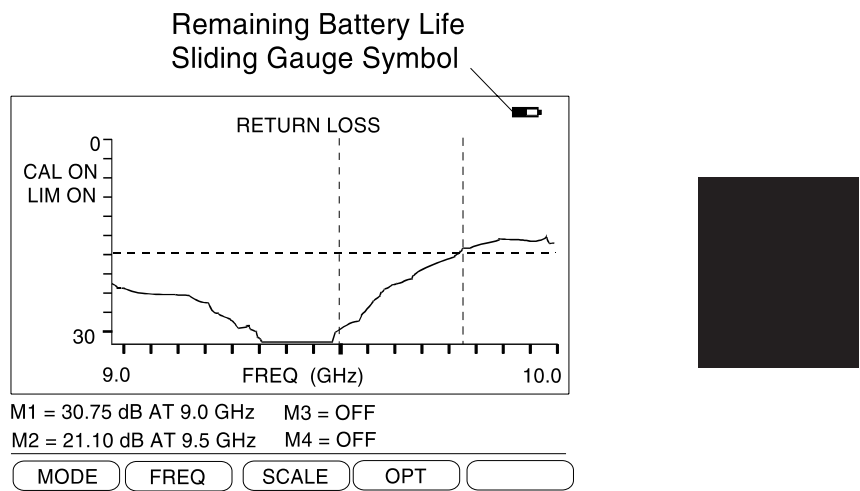



Figure 2-9. Battery Monitor

Making Frequency-Domain Measurements

Frequency domain measurements consist of Standing Wave Ratio (SWR), Return Loss (RL), or Coax/Waveguide Loss (CWL) measurements made over a selectable frequency range.

Return Loss or SWR Measurement

Selecting a Frequency Range

- 
- Step 1.** Press the **MODE** soft key, from the Main Menu (page 2-8).
 - Step 2.** Select SWR or Return Loss measurement using the Up/Down Arrow key. Press **ENTER** when selection is complete.
 - Step 3.** Press the **FREQ** soft key, from the Main Menu (page 2-8).
 - Step 4.** Press the **F1** soft key from the Frequency Menu (page 2-11).
 - Step 5.** Enter the desired numerical value using the keypad or the Up/Down Arrow key (Figure 2-1, page 2-0). Press **ENTER** when data entry is complete.
 - Step 6.** Press the **F2** soft key.
 - Step 7.** Enter the desired numerical value using the keypad or the Up/Down Arrow key. Press **ENTER** when data entry is complete.
 - Step 8.** Check that the **FREQ** (GHz) scale in the display area indicates the new frequency start and stop values.

Performing a Calibration

- Step 9.** Perform a measurement calibration using the START CAL key. Select either COAX or WAVEGUIDE calibration type. Select the desired setup configuration from the following menu. Once setup is complete, select START CALIBRATION from the menu and press ENTER.

For COAX:

Follow the ensuing “Connect OPEN, Press ENTER,” “Connect SHORT, Press ENTER,” and “Connect LOAD, Press ENTER” instructions that appear in the message area. Connect the respective Open, Short, and Load components to the end of the Test Port Extension Cable (Figure 2-8, page 2-26) prior to pressing ENTER.

After each selection, the message “Measuring OPEN,” “Measuring SHORT,” or “Measuring LOAD” appears while the measurement is in progress.

For WAVEGUIDE:

Follow the ensuing “Connect SHORT 1, Press ENTER,” “Connect SHORT 2, Press ENTER,” and “Connect LOAD, Press ENTER” instructions that appear in the message area. Connect the respective Short 1, Short 2, and Load components to the end of the Test Port Extension Cable (Figure 2-8) prior to pressing ENTER.

After each selection, the message “Measuring SHORT 1,” “Measuring SHORT 2,” or “Measuring LOAD” appears while the measurement is in progress.



NOTES:

For best calibration results — compensation for all measurement system uncertainties — ensure that the Open/Short/Load (Short 1/Short 2/Load for waveguide) is at the end of the test port or optional extension cable; that is, at the same point that you will connect the antenna or device to be tested.

*For best results, use a phase stable Test Port Extension Cable (see Optional Accessories). If you use a typical laboratory cable to extend the **Site Master** test port to the device-under-test, cable bending subsequent to the Open/ Short/Load calibration will cause uncompensated phase reflections inside the cable. Thus, cables which are NOT phase stable may cause measurement errors that are more pronounced as the test frequency increases.*

For optimum calibration, ANRITSU recommends using precision calibration components.

Making a Measurement

- Step 10.** Connect the device-under-test to the **Site Master** Test Port or the Test Port Extension Cable.
- Step 11.** Observe the displayed waveform.

Scaling the Display

- Step 12.** The display can be scaled using either of the following methods:
 - Automatically scale the display using the **AUTO SCALE** key (Figure 2-1, page 2-0).
 - Manually scale the display using the **LIMIT** key or the **SCALE** soft key—from the Main Menu—and the **TOP** and **BOTTOM** soft keys from the ensuing soft key menu (page 2-12).

Adjusting Markers

- Step 13.** Press the **MARKER** key (Figure 2-1, page 2-0) to call up the Markers Menu. (Maximum of 4 available markers)
- Step 14.** Press the **M1** soft key on the Markers Menu to select Marker 1. This will open the Markers 2nd Level Menu. Press the **ON/OFF** soft key to turn M1 on. Press the **EDIT** soft key to open the M1 parameter for data entry. Enter the desired numerical value using the keypad or the Up/Down Arrow key (Figure 2-1, page 2-0). Press **ENTER** when the data entry is complete.
- Step 15.** Press the **BACK** soft key to return to the Markers Menu.
- Step 16.** Press the **M2** soft key on the Markers Menu to select Marker 2. This will open the Markers 2nd Level Menu. Press the **ON/OFF** soft key to turn M2 on. Press the **EDIT** soft key to open the M2 parameter for data entry. Enter the desired numerical value using the keypad or the Up/Down Arrow key (Figure 2-1, page 2-0). Press **ENTER** when the data entry is complete.
- Step 17.** Press the **DELTA** soft key to display the difference between M2 and M1 in SWR (dB) and in frequency. The delta function displays the difference of M2, M3, or M4 with respect to M1.
- Step 18.** Press the **BACK** and the **MAIN** soft key to return to the Main Menu.

Adjusting a Limit

- Step 19.** Press the **LIMIT** key (Figure 2-1, page 2-0) to call up the Scale Menu.

- Step 20.** If the Limit needs to be turned OFF, press the **LIMIT** soft key on the Scale Menu. If the Limit needs to be turned ON, press the **LIMIT** soft key again. This will open the Limit parameter for entry. If needed, enter the desired numerical value using the keypad or the Up/Down Arrow key (Figure 2-1, page 2-0). Press ENTER when the data entry is complete.
- Step 21.** If you wish to have an audible beep when the trace is above the limit line, press the **OPT** soft key from the Main Menu (page 2-8).
- Step 22.** Press the **B2** soft key from the Option Menu (page 2-13) to toggle the limit beep indicator ON.



Saving a Setup

- Step 23.** Press the SAVE SETUP key (Figure 2-1, page 2-0).
- Step 24.** Enter the desired numerical value (1 to 6) using the Up/Down Arrow key. Press ENTER when data entry is complete.

Recalling a Setup

- Step 25.** Press the RECALL SETUP key.
- Step 26.** Enter the desired numerical value (1 to 6) using the Up/Down Arrow key. Press ENTER when data entry is complete. To restore the factory defaults, enter 0, then press ENTER.

Storing a Display

- Step 27.** Press the SAVE DISPLAY key and it will display the next available memory location.
- Step 28.** Press ENTER to store the display in the current empty memory location or enter the desired numerical value using the keypad (1 to 70) or the Up/Down Arrow key. Press ENTER when entry is complete.

- Step 29.** Enter the current time in *HHMM* format. Press ENTER when entry is complete.
- Step 30.** Enter the current date in *DDMMYY* format. Press ENTER when entry is complete.
- Step 31.** Enter an 8-digit reference designator. Press ENTER when entry is complete.

Recalling a Display

- Step 32.** Press the RECALL DISPLAY key.
- Step 33.** Enter the desired numerical value using the keypad (1 to 70) or the Up/Down Arrow key. Press ENTER when data entry is complete.



Coax/Waveguide Loss Measurement

Selecting a Frequency Range

- Step 1.** Press the **MODE** soft key, from the Main Menu (page 2-8).
- Step 2.** Select Coax/Waveguide Loss measurement using the Up/Down Arrow key. Press ENTER when selection is complete.
- Step 3.** Press the **FREQ** soft key, from the Main Menu (page 2-8).
- Step 4.** Press the **F1** soft key from the Frequency Menu (page 2-11).
- Step 5.** Enter the desired numerical value using the keypad or the Up/Down Arrow key (Figure 2-1, page 2-0). Press ENTER when data entry is complete.
- Step 6.** Press the **F2** soft key.

Step 7. Enter the desired numerical value using the keypad or the Up/Down Arrow key. Press ENTER when data entry is complete.

Step 8. Check that the **FREQ (GHz)** scale in the display area indicates the new frequency start and stop values.

Performing a Calibration

Step 9. Perform a measurement calibration using the **START CAL** key. Select either **COAX** or **WAVEGUIDE** calibration type. Select the desired setup configuration from the following menu. Once setup is complete, select **START CALIBRATION** from the menu and press **ENTER**.



For COAX:

Follow the ensuing “Connect OPEN, Press ENTER,” “Connect SHORT, Press ENTER,” and “Connect LOAD, Press ENTER” instructions that appear in the message area. Connect the respective Open, Short, and Load components to the end of the Test Port Extension Cable (Figure 2-8, page 2-26) prior to pressing ENTER.

After each selection, the message “Measuring OPEN,” “Measuring SHORT,” or “Measuring LOAD” appears while the measurement is in progress.

For WAVEGUIDE:

Follow the ensuing “Connect SHORT 1, Press ENTER,” “Connect SHORT 2, Press ENTER,” and “Connect LOAD, Press ENTER” instructions that appear in the message area. Connect the respective Short 1, Short 2, and Load components to the end of the Test Port Extension Cable (Figure 2-8) prior to pressing ENTER.

After each selection, the message “Measuring SHORT 1,” “Measuring SHORT 2,” or “Measuring LOAD” appears while the measurement is in progress.

NOTES:

For best calibration results — compensation for all measurement system uncertainties — ensure that the Open/Short/Load (Short 1/Short 2/Load for waveguide) is at the end of the test port or optional extension cable; that is, at the same point that you will connect the antenna or device to be tested.

*For best results, use a phase stable Test Port Extension Cable (see Optional Accessories). If you use a typical laboratory cable to extend the **Site Master** test port to the device-under-test, cable bending subsequent to the Open/ Short/Load calibration will cause uncompensated phase reflections inside the cable. Thus, cables which are **NOT** phase stable may cause measurement errors that are more pronounced as the test frequency increases.*

For optimum calibration, ANRITSU recommends using precision calibration components.

Making a Measurement

- Step 10.** Connect the cable to be tested to the **Site Master** Test Port or the end of the Test Port Extension Cable (if used).
- Step 11.** Place an Open or Short at the other end of the cable.
- Step 12.** Observe the displayed cable loss vs frequency.

Scaling the Display

- Step 13.** The display can be scaled using either of the following methods:
- ❑ Automatically scale the display using the **AUTO SCALE** key (Figure 2-1, page 2-0).
 - ❑ Manually scale the display using the **LIMIT** key or the **SCALE** soft key—from the Main Menu—and the **TOP** and **BOTTOM** soft keys from the ensuing soft key menu (page 2-12).



Adjusting Markers

- Step 14.** Press the **MARKER** key (Figure 2-1, page 2-0) to call up the Markers Menu (Maximum of 4 available markers).
- Step 15.** Press the **M1** soft key on the Markers Menu to select Marker 1. This will open the Markers 2nd Level Menu. Press the **ON/OFF** soft key to turn M1 on. Press the **EDIT** soft key to open the M1 parameter for data entry. Enter the desired numerical value using the keypad or the Up/Down Arrow key (Figure 2-1, page 2-0). Press **ENTER** when the data entry is complete.
- Step 16.** Press the **BACK** soft key to return to the Markers Menu.
- Step 17.** Press the **M2** soft key on the Markers Menu to select Marker 2. This will open the Markers 2nd Level Menu. Press the **ON/OFF** soft key to turn M2 on. Press the **EDIT** soft key to open the M2 parameter for data entry. Enter the desired numerical value using the keypad or the Up/Down Arrow key (Figure 2-1, page 2-0). Press **ENTER** when the data entry is complete.

- Step 18.** Press the **DELTA** soft key to display the difference between M2 and M1 in dB and frequency. (The delta function only displays the difference of M2, M3, or M4 with respect to M1.)
- Step 19.** Press the **BACK** and the **MAIN** soft key to return to the Main Menu.

Adjusting a Limit

- Step 20.** Press the **LIMIT** key (Figure 2-1, page 2-0) to call up the Scale Menu.
- Step 21.** If the Limit needs to be turned OFF, press the **LIMIT** soft key on the Scale Menu. If the Limit needs to be turned ON, press the **LIMIT** soft key again. This will open the Limit parameter for entry. If needed, enter the desired numerical value using the keypad or the Up/Down Arrow key (Figure 2-1, page 2-0). Press **ENTER** when the data entry is complete.
- Step 22.** If you wish to have an audible beep when the trace is above the limit line, press the **OPT** soft key from the Main Menu (page 2-8).
- Step 23.** Press the **B2** soft key from the Option Menu (page 2-13) to toggle the limit beep indicator ON.



Saving a Setup

- Step 24.** Press the **SAVE SETUP** key (Figure 2-1, page 2-0).
- Step 25.** Enter the desired numerical value (1 to 6) using the Up/Down Arrow key. Press **ENTER** when data entry is complete.

Recalling a Setup

- Step 26.** Press the **RECALL SETUP** key.

- Step 27.** Enter the desired numerical value (1 to 6) using the Up/Down Arrow key. Press ENTER when data entry is complete. To restore the factory defaults, enter 0, then press ENTER.

Storing a Display

- Step 28.** Press the SAVE DISPLAY key. This will display the next available empty memory location.
- Step 29.** Press ENTER to store the display in the current empty memory location or enter the desired numerical value using the keypad (1 to 70) or the Up/Down Arrow key. Press ENTER when entry is complete.
- Step 30.** Enter the current time in *HHMM* format. Press ENTER when entry is complete.
- Step 31.** Enter the current date in *DDMMYY* format. Press ENTER when entry is complete.
- Step 32.** Enter an 8-digit reference designator. Press ENTER when entry is complete.

Recalling a Display

- Step 33.** Press the RECALL DISPLAY key.
- Step 34.** Enter the desired numerical value using the keypad (1 to 70) or the Up/Down Arrow key. Press ENTER when data entry is complete.

Making Distance-Domain Measurements

Distance domain measurements—commonly known as distance-to-fault (DTF)—are made over a selectable distance range. They return information that can help locate discontinuities in a transmission line.

Selecting a Frequency Range

NOTE FOR COAX:

The maximum distance range is determined by the frequency span, number of data points, and relative propagation velocity:

$$\text{Maximum Unaliased Range (meters)} = \frac{(15 \cdot 10^8) (128) (V_f)}{F_2 - F_1}$$

Where: F_1 is start frequency (in Hz)
 F_2 is stop frequency (in Hz)
 V_f is relative propagation velocity

NOTE FOR WAVEGUIDE:

The maximum distance range is determined by the frequency span, number of data points, and group velocity:

$$\text{Maximum Unaliased Range (meters)} = \frac{(15 \cdot 10^8) (128) (V_G)}{F_2 - F_1}$$

Where: F_1 is start frequency (in Hz)
 F_2 is stop frequency (in Hz)
 V_G is group velocity
 $V_G = \sqrt{1 - (F_c/F_1)^2}$
 F_c is cutoff frequency (in Hz)

- Step 1.** Press the **MODE** soft key, from the Main Menu (page 2-8).
- Step 2.** Select DTF-SWR or Return Loss measurement using the Up/Down Arrow key (Figure 2-1, page 2-0). Press **ENTER** when selection is complete.

Step 3. For COAX:

Use the Up/Down Arrow key and press ENTER to select DTF table parameters—D1, D2, CF, CABLE, PROP VEL, or LOSS. For each parameter selected, enter the desired numerical value using the keypad or the Up/Down Arrow key. Press ENTER when data entry is complete.

For WAVEGUIDE:

Use the Up/Down Arrow key and press ENTER to select DTF table parameters—D1, D2, CF, WAVEGUIDE TYPE, CUTOFF, or LOSS. For each parameter selected, enter the desired numerical value using the keypad or the Up/Down Arrow key. Press ENTER when data entry is complete.



NOTE:

*The DTF table will not automatically display if the current calibration is valid. To display DTF table parameters, press the **DIST** soft key from the Main Menu and then press the **DTF AID** soft key from the ensuing soft key menu. Changing CF, Media Type, or D2 will require a new calibration.*

Performing a Calibration

- Step 4.** Perform a measurement calibration using the START CAL key. Select either COAX or WAVEGUIDE calibration type. Select the desired setup configuration from the following menu. Once setup is complete, select START CALIBRATION from the menu and press ENTER.

For COAX:

Follow the ensuing "Connect OPEN, Press ENTER," "Connect SHORT, Press ENTER," and "Connect LOAD, Press ENTER" instructions that appear in the message area. Connect the respective Open, Short, and Load components to the end of the Test Port Extension Cable (Figure 2-8, page 2-26) prior to pressing ENTER.

After each selection, the message "Measuring OPEN," "Measuring SHORT," or "Measuring LOAD" appears while the measurement is in progress.

For WAVEGUIDE:

Follow the ensuing "Connect SHORT 1, Press ENTER," "Connect SHORT 2, Press ENTER," and "Connect LOAD, Press ENTER" instructions that appear in the message area. Connect the respective Short 1, Short 2, and Load components to the end of the Test Port Extension Cable (Figure 2-8) prior to pressing ENTER.

After each selection, the message "Measuring SHORT 1," "Measuring SHORT 2," or "Measuring LOAD" appears while the measurement is in progress.



NOTES:

For best calibration results — compensation for all measurement system uncertainties — ensure that the Open/Short/Load (Short 1/Short 2/Load for waveguide) is at the end of the test port or optional extension cable; that is, at the same point that you will connect the antenna or device to be tested.

For best results, use a phase stable Test Port Extension Cable (see Optional Accessories). If you use a typical laboratory cable to extend the Site Master test port to the device-under-test, cable bending subsequent to the Open/Short/Load calibration will cause uncompensated phase reflections inside the cable. Thus, cables which are NOT phase stable may cause measurement errors that are more pronounced as the test frequency increases.

For optimum calibration, ANRITSU recommends using precision calibration components.

Performing aDTF Measurement

- Step 5.** Connect the device-under-test to the Site Master Test Port or the end of the Test Port Extension Cable (if used).
- Step 6.** Observe the displayed waveform.

NOTES:

Changing D1, D2, Cable Type, Waveguide Type, Cutoff Frequency, Propagation Velocity, and Loss within the valid range will not invalidate the calibration. However; changing CF and/or D2 beyond its maximum calibrated range or changing media type will require a new calibration.

*Press the **B5** soft key from the Option Sub-Menu (page 2-14) to toggle between feet and meters. Values entered in either will freely convert to the other.*

Loss and relative propagation velocity values for many common cable types and cutoff frequency and mid-band loss for many common waveguide types are listed in the tables in Appendix A.



Scaling the Display

- Step 7.** The display can be scaled using either of the following methods:
- Automatically scale the display using the **AUTO SCALE** key (Figure 2-1, page 2-0).
 - Manually scale the display using the **LIMIT** key or the **SCALE** soft key—from the Main Menu—and the **TOP** and **BOTTOM** soft keys from the ensuing soft key menu (page 2-12).

Adjusting Markers

- Step 8.** Press the **MARKER** key (Figure 2-1, page 2-0) to call up the Markers Menu (Maximum of 4 available markers).
- Step 9.** Press the **M1** soft key on the Markers Menu to select Marker 1. This will open the Markers 2nd Level Menu. Press the **ON/OFF** soft key to turn M1 on.

Press the **EDIT** soft key to open the M1 parameter for data entry. Enter the desired numerical value using the keypad or the Up/Down Arrow key (Figure 2-1, page 2-0). Press **ENTER** when the data entry is complete.

- Step 10.** Press the **BACK** soft key to return to the Markers Menu.
- Step 11.** Press the **M2** soft key on the Markers Menu to select Marker 2. This will open the Markers 2nd Level Menu. Press the **ON/OFF** soft key to turn M2 on. Press the **EDIT** soft key to open the M2 parameter for data entry. Enter the desired numerical value using the keypad or the Up/Down Arrow key (Figure 2-1, page 2-0). Press **ENTER** when the data entry is complete.
- Step 12.** Press the **DELTA** soft key to display the difference between M2 and M1 in SWR (dB) and in distance. The delta function displays the difference of M2, M3, or M4 with respect to M1.
- Step 13.** Press the **BACK** and the **MAIN** soft key to return to the Main Menu.

Adjusting a Limit

- Step 14.** Press the **LIMIT** key (Figure 2-1, page 2-0) to call up the Scale Menu.
- Step 15.** If the Limit needs to be turned OFF, press the **LIMIT** soft key on the Scale Menu. If the Limit needs to be turned ON, press the **LIMIT** soft key again. This will open the Limit parameter for entry. If needed, enter the desired numerical value using the keypad or the Up/Down Arrow key (Figure 2-1, page 2-0). Press **ENTER** when the data entry is complete.

- Step 16.** If you wish to have an audible beep when the trace is above the limit line, press the **OPT** soft key from the Main Menu (page 2-8).
- Step 17.** Press the **B2** soft key from the Option Menu (page 2-13) to toggle the limit beep indicator ON.

Saving a Setup

- Step 18.** Press the SAVE SETUP key (Figure 2-1, page 2-0).
- Step 19.** Enter the desired numerical value (1 to 6) using the Up/Down Arrow key. Press ENTER when data entry is complete.

Recalling a Setup

- Step 20.** Press the RECALL SETUP key.
- Step 21.** Enter the desired numerical value (1 to 6) using the Up/Down Arrow key. Press ENTER when data entry is complete. To restore the factory defaults, enter 0, then press ENTER.

Storing a Display

- Step 22.** Press the SAVE DISPLAY key. This will display the next available empty memory location.
- Step 23.** Press ENTER to store the display in the current empty memory location or enter the desired numerical value using the keypad (1 to 70) or the Up/Down Arrow key. Press ENTER when entry is complete.
- Step 24.** Enter the current time in *HHMM* format. Press ENTER when entry is complete.
- Step 25.** Enter the current date in *DDMMYY* format. Press ENTER when entry is complete.
- Step 26.** Enter an 8-digit reference designator. Press ENTER when entry is complete.

Recalling a Display

- Step 27.** Press the **RECALL DISPLAY** key.
- Step 28.** Enter the desired numerical value using the keypad (1 to 70) or the Up/Down Arrow key. Press **ENTER** when data entry is complete.

Making Power Measurements

Power measurement is accomplished using an ANRITSU broadband (10 MHz to 20 GHz) RF detector, P/N 560-7N50B. The power monitor displays the measured power in dBm or Watts.



Entering Power Monitor Mode

- Step 1.** Press the **MODE** soft key, from the Main Menu (page 2-8)
- Step 2.** Select **POWER MONITOR** using the Up/Down Arrow key. Press **ENTER** when selection is complete.

Zeroing the Power Monitor

- Step 3.** With no power applied to the DUT, press the **ZERO** soft key from the Power Monitor menu (page 2-10). Wait a few seconds while the **Site Master** accumulates samples of the quiescent power level. When complete, **ZERO ADJ: ON** is displayed in the message area.

Measuring High Input Power Levels

- Step 4.** Insert an attenuator between the DUT and the RF detector, sufficient to insure that the input power to the **Site Master** is no greater than 20 dBm.
- Step 5.** Press the **OFFSET** soft key.
- Step 6.** Enter the attenuation in dB using the keypad. Press **ENTER** to complete the entry. The message area will

show OFFSET is ON along with the entered value in dB.

Displaying Power in dBm and Watts

Step 7. Press the **UNITS** soft key to display power in Watts.

Displaying Relative Power

Step 8. With the desired base power level input to the **Site Master**, press the **REL** soft key. The message area will show REL: ON and the power reading will indicate 100%.

Step 9. Press the **UNITS** soft key to display power in dBm. Since REL is ON, the power reading will be in dB_r, relative to the base power level.



Printing

Printing is accomplished with either of two printers: the Seiko DPU-411 thermal printer or the Hewlett Packard DeskJet 340 ink jet printer. Figure 2-11 shows a setup diagram for these two printers.

Printer Switch Settings

Set the switches, SW1 and SW2, on the Seiko DPU-411 thermal printer as follows:

<u>Switch</u>	<u>1</u>	<u>2</u>	<u>3</u>	<u>4</u>	<u>5</u>	<u>6</u>	<u>7</u>	<u>8</u>
SW1	OFF	ON	ON	ON	ON	OFF	ON	ON
SW2	ON	ON	ON	OFF	OFF	OFF		

Set the switches on the serial-to-parallel interface cable to the HP Desk-jet 340 ink jet printer as follows:

<u>SW1</u>	<u>SW2</u>	<u>SW3</u>	<u>SW4</u>	<u>SW5</u>	<u>SW6</u>	<u>SW7</u>	<u>SW8</u>
OFF	ON	OFF	OFF	OFF	OFF	OFF	OFF

Printing a Screen

- Step 1.** Connect the printer as shown in Figure 2-11.
- Step 2.** Obtain a SWR, RL, CWL, or Distance-to-Fault measurement display.
- Step 3.** Select the printer using the **B6** soft key from the Option Sub-Menu (page 2-14).
- Step 4.** Press the PRINT key (Figure 2-1, page 2-0).

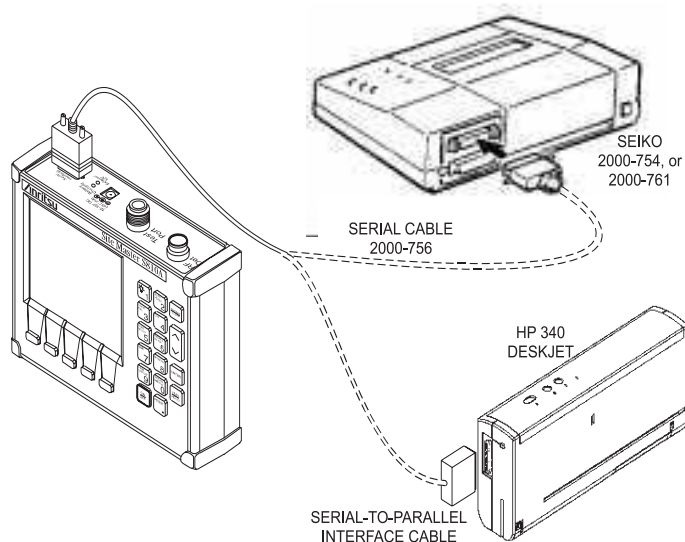

Figure 2-11. Printer Setup

Symbols

Table 2-1 provides a listing of the symbols used as condition indicators on the LCD display.

Self Test

At turn-on, the **Site Master** runs through a series of quick checks to ensure the system is functioning properly. Note that the battery voltage and temperature are displayed in the lower left corner below the self test message. If the battery is low, or if the ambient temperature is not within the specified operational range, Self Test will fail. If Self Test fails AND the battery is fully charged AND the **Site Master** is within the specified operating range, call your ANRITSU Service Center.



Error Codes

Self Test Errors

A listing of Self Test Error messages is given in Table 2-2.







Range Errors

A listing of Range Error messages is given in Table 2-3.

Replacing the Battery

Replacing the battery is the only recommended field-level maintenance action. If your battery fails, contact your ANRITSU Sales Office or Service Center. Table 2-4, on page 2-58, provides a listing of current service centers.

Table 2-2. LCD Icon Symbols

<u>Icon</u>	<u>Symbol</u>
	Site Master is in Hold or Power Conservation mode. To resume sweeping, press the RUN/HOLD key. After 10 minutes without a key press, the Site Master will automatically enter into its power conservation mode.
	Site Master is in keypad lockout mode. To turn off keypad lockout, use the B3 soft key (page 2-13).
	Lock fail indication. Check battery. (If Site Master fails to lock with a fully charged battery, call your ANRITSU Service Center.)
	Processor timeout failure. Symbol appears at the frequency that causes an input RF overload; it then disappears as the sweep continues past that point.
	When calibration is performed, the Site Master stores the ambient temperature. If the temperature drifts outside the specified range, this indicator will flash. A recalibration at the current temperature is recommended.
	Indicates the remaining charge on the battery. The inner white rectangle grows longer as the battery charge depletes.



Chapter 2 Operation

Table 2-3. Self Test Error Messages

<u>Error Message</u>	<u>Description</u>
BATTERY LOW	Battery voltage is less than 12.5 volts. Charge battery. If condition persists, call your ANRITSU Service Center.
EXTERNAL POWER LOW	External supply voltage is less than 12.5 volts. Call your ANRITSU Service Center
PLL FAILED	Phase-locked loops failed to lock. Charge battery. If condition persists with a fully charged battery, call your ANRITSU Service Center
INTEGRATOR FAILED	Integration circuit could not charge to a valid level. Charge battery. If condition persists with a fully charged battery, call your ANRITSU Service Center.
EEPROM R/W FAILED	Non-volatile memory system has failed. Call your ANRITSU Service Center.
OUT OF TEMP. RANGE	Ambient temperature is not within the specified operating range. Return temperature to specified operating range. If condition persists, call your ANRITSU Service Center.

Note: A listing of current ANRITSU service centers is given in Table 2-4.

Table 2-4. Range Error Messages (1 of 2)

Error Message	Description
RANGE ERROR:F1 > F2	The start (F1) frequency is greater than the stop (F2) frequency.
RANGE ERROR:D1 > D2	The start (D1) distance is greater than the stop (D2) distance.
RANGE ERROR:D2 > DMax=xx.x ft (m)	The stop distance (D2) exceeds the maximum unaliased range. This range is determined by the frequency span, number of points, and relative propagation velocity or group velocity: COAX: $\text{Max Unaliased Range (meters)} = \frac{(1.5 \times 10^8) (128) (V_f)}{F2 - F1}$ WAVEGUIDE: $\text{Max Unaliased Range (meters)} = \frac{(1.5 \times 10^8) (128) (V_g)}{F2 - F1}$ <p>Where: F1 is start frequency (in Hz) F2 is stop frequency (in Hz) Vf is relative propagation velocity Vg is group velocity.</p>
RANGE ERROR: TOP<=BOTTOM	The SWR scale parameter top value is less than or equal to its bottom value.
RANGE ERROR: TOP>=BOTTOM	The RL scale parameter top value is greater than or equal to its bottom value.
CAL INCOMPLETE	A complete open, short, and load calibration must be performed before calibration can be turned on.
CAL VALID FROM: xxx.x to xxx.x MHz	The calibration was performed at a frequency range that is different from the current range.
DIST REQUIRES F1 < F2	Valid distance to fault plots require a non-zero frequency span.



Chapter 2 Operation

Table 2-3. Range Error Messages (2 of 2)

Error Message	Description
DIST REQUIRES CAL	Distance-to-fault measurements do not provide usable data with CAL OFF.
NO STORED SWEEP AT THIS LOCATION	Attempting to recall a display from a location that has not been previously written to. That is, the location does not contain stored sweep.
USE OPTIONS MENU TO SELECT A PRINTER	Attempting to print a display with no printer selected. Select a printer, then retry.
DISTANCE AND COAX/WAVEGUIDE LOSS MODE ARE INCOMPATIBLE	DTF measurements only display RL or SWR versus distance.
CANNOT ZERO NO DETECTOR INSTALLED	Attempting to perform a Power Monitor zero adjust function with no RF detector connected to the Site Master .
CANNOT ZERO INPUT SIGNAL TOO HIGH	Attempting to perform a Power Monitor zero adjust function with an input of greater than -20 dBm.
POWER MONITOR OPTION NOT INSTALLED	Attempting to enter Power Monitor mode with no option 5 installed.

Using the Soft Carrying Case

The soft carrying case has been designed such that the strap can be un-snapped to allow the case to be easily oriented horizontally; thus allowing the **Site Master** controls to be more easily accessed (Figure 2-12).

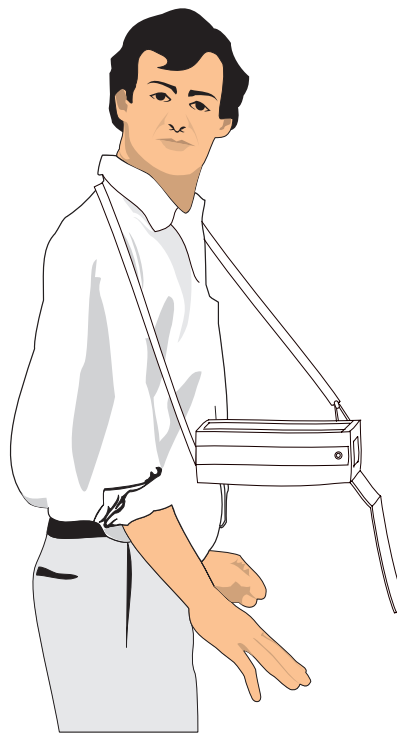

Figure 2-12. Using Soft Carrying Case

Chapter 2 Operation

Table 2-4. ANRITSU Service Centers (1 of 2)

UNITED STATES

ANRITSU COMPANY
685 Jarvis Drive
Morgan Hill, CA 95037-2809
Telephone: (408) 776-8300
FAX: 408-776-1744

ANRITSU COMPANY
10 Kingsbridge Road
Fairfield, NJ 07004
Telephone: (201) 227-8999
FAX: 201-575-0092

AUSTRALIA

ANRITSU PTY. LTD.
Unit 3, 170 Foster Road
Mt. Waverly, VIC 3149
Australia
Telephone: 03-9558-8177
Fax: 03-9558-8255

BRAZIL

ANRITSU ELECTRONICA LTDA.
Praia de Botafogo 440, Sala 2401
CEP 22250-040, Rio de Janeiro, RJ, Brasil
Telephone: 021-28-69-141
Fax: 021-53-71-456

CANADA

ANRITSU INSTRUMENTS LTD.
215 Stafford Road, Unit 102
Nepean, Ontario K2H 9C1
Telephone: (613) 828-4090
FAX: (613) 828-5400

CHINA

ANRITSU BEIJING SERVICE CENTER
Beijing Fortune Building
416W, 5 Dong San Huan Bei Lu
Chaoyang qu
Beijing 100004, China
Telephone: 010-501-7559
FAX: 010-501-7558

FRANCE

ANRITSU S.A
9 Avenue du Quebec
Zone de Courtaboeuf
91951 Les Ulis Cedex
Telephone: 016-44-66-546
FAX: 016-44-61-065

GERMANY

ANRITSU GmbH
Grafenberger Allee 54-56
D-40237 Dusseldorf
Germany
Telephone: 0211-67 97 60
FAX: 0211-68 33 53

INDIA

MEERA AGENCIES (P) LTD
A-23 Hauz Khas
New Delhi 110 016
Telephone: 011-685-3959
FAX: 011-686-6720

ISRAEL

TECH-CENT, LTD
Haarad St. No. 7, Ramat Haahayal
Tel-Aviv 69701
Telephone: (03) 64-78-563
FAX: (03) 64-78-334

ITALY

ANRITSU Sp.A
Rome Office
Via E. Vittorini, 129
00144 Roma EUR
Telephone: (06) 50-22-666
FAX: (06) 50-22-4252

JAPAN

ANRITSU CORPORATION
1800 Onna Atsugi-shi
Kanagawa-Prf. 243 Japan
Telephone: 0462-23-1111
FAX: 0462-25-8379

Table 2-4. ANRITSU Service Centers (2 of 2)

KOREA

ANRITSU KOREA (AWK)
#901 Daeo Bldg. 26-5
Yeoido Dong, Youngdeungpo
Seoul Korea 150 010
Telephone: 02-782-7156
FAX: 02-782-4590

SINGAPORE

ANRITSU (SINGAPORE) PTE LTD
3 Shenton Way #24-03
Shenton House
Singapore 0106
Telephone: 2265206
FAX: 2265207

SOUTH AFRICA

ETESCSA
1st Floor Montrose Place
Waterfall Park, Becker Road
MIDRAND
SOUTH AFRICA
Telephone: 011-315-1366
Fax: 011-315-2175

SWEDEN

ANRITSU ANRITSU AB
Box 247
S-127 25 Skarholmen
Telephone: (08) 74-05-840
FAX: (08)71-09-960

TAIWAN

ANRITSU CO., LTD.
8F, No. 96, Section 3
Chien Kuo N. Road
Taipei, Taiwan, R.O.C.
Telephone: (02) 515-6050
FAX: (02) 509-5519

UNITED KINGDOM

ANRITSU LTD.
200 Capability Green
Luton, Bedfordshire
LU1 3LU, England
Telephone: 015-82-41-88-53
FAX: 015-82-31-303



Chapter 3

Software Tools

Program

Description

The **Site Master** Software Tools program provides the means for transferring the measured trace, along with any applied markers and/or a limit, to the screen of an MS-DOS based personal computer (PC) running Windows, Windows for Workgroups 3.xx, Windows NT, or Windows 95.

Requirements

The **Site Master** Software Tools program is a standard Windows 3.x program and will run on any computer that will run Windows, Windows for Workgroups 3.xx, Windows NT, or Windows 95. Typically, this means having a PC with the following characteristics:

- 386 or better microprocessor running enhanced mode (386DX, 33 MHz or better, recommended).
- 8 MBytes of memory, minimum.
- Hard Disk Drive, with approximately 3 MBytes of available space.



Communication Port Setting

The **Site Master** Software Tools communicates with the **Site Master** through a standard COM port on the PC. It is important that your Windows COM port settings conform to the actual hardware settings. Table 3-1 provides a listing of standard COM port settings for most IBM AT-Compatible computers.

Table 3-1. Standard COM Port Settings

Port	IRQ	Address
COM1	4	3F8
COM2	3	2F8
COM3	4	3E8
COM4	3	2E8

Since various add-in devices such as sound cards, modems, and network cards use IRQ (Interrupts), it is possible that your computer has non-standard COM port settings. Please consult your computer vendor for COM port address and IRQ information.

Changing COM Port Settings—Windows 3.1

Refer to Figure 3-1 while performing the following procedure.

- Step 1.** Open the **Windows Control Panel**.
- Step 2.** Double click on the **Ports** icon. The Ports dialog box appears.
- Step 3.** Click on the icon for the COM Port whose communications settings you wish to specify, then click the **Settings...** button. The Settings dialog box appears.
- Step 4.** Change to the following settings if necessary:
 - Baud Rate: 9600
 - Data Bits: 8
 - Parity: None
 - Stop Bits: 1
 - Flow Control: None

3 - 2

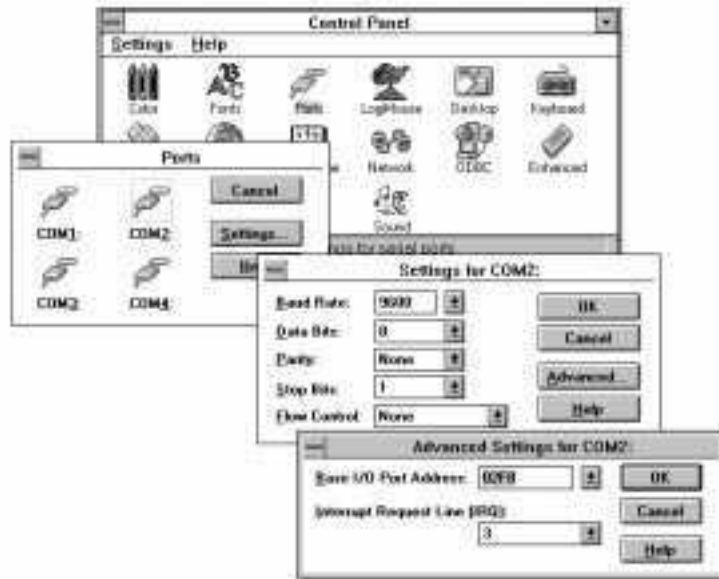

Figure 3-1. Windows 3.1 COM Port Setting Dialog Boxes

- Step 5.** Click on the **Advanced...** button. At the Advanced Settings dialog box verify the COM Port Base Address and IRQ. Click **OK** when done.
- Step 6.** Click **OK** again and then **Close** to close the COM Port Setting Windows.

Note:
If you changed the COM Port Base Address and/or IRQ, you will need to restart Windows.

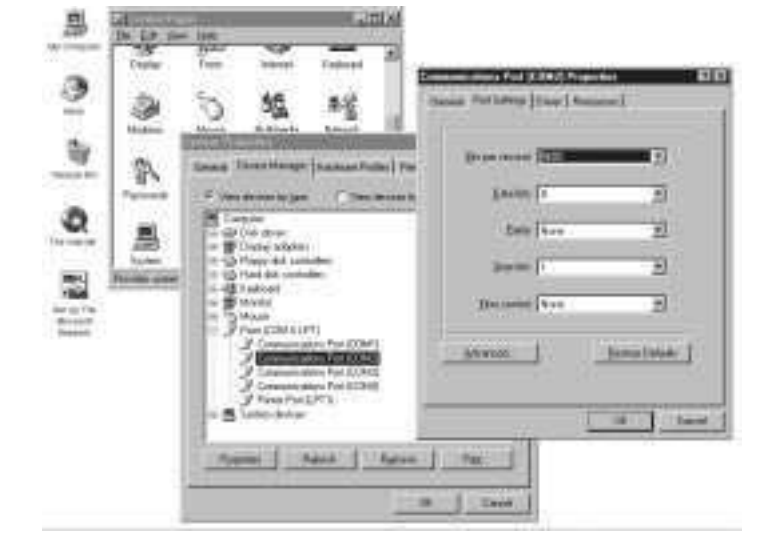

Figure 3-2. Windows 95 COM Port Setting Dialog Boxes

Changing COM Port Settings—Windows 95

Refer to Figure 3-2 while performing the following procedure.

- Step 1.** Open the **Windows Control Panel**.
- Step 2.** Double click on the **SYSTEM** icon. The System Properties window appears.
- Step 3.** Select **Device Manager**. The Device List appears.
- Step 4.** Double click on the item **Ports (COM & LPT)** in the device list.
- Step 5.** Double click on the **Communications Port** you want to set. The Communications Port Properties window appears.

NOTE:

If Windows doesn't show any available COM Ports, consult your computer manufacturer.

3 - 4

- Step 6.** Choose **Port Settings**, then change to the following settings if necessary.
- Baud Rate: 9600
 - Data Bits: 8
 - Parity: None
 - Stop Bits: 1
 - Flow Control: None
- Step 7.** Choose **Resource** and verify the COM Port Base Address and IRQ. Click **OK** when done.
- Step 8.** Click **OK** again to close the System Properties window.

Note:
If you changed the COM Port Base Address and/or IRQ, you will need to restart Windows.

Software Installation

The **Site Master** Software Tools program is a conventional Microsoft Windows 3.x program. Installation is similar to all other such programs. For users new to Windows 3.x, a detailed procedure is given below.

- Step 1.** Insert the ANRITSU **Site Master** Software Tools For Windows disk in floppy drive A:\ or B:\.
- Step 2.** In the Windows Program Manager, pull down the File menu and select Run. (For Windows 95 users, select Run under the Start menu.)
- Step 3.** Type A: (or B:)\SETUP, when the dialog box appears.
- Step 4.** Press the Enter key to select the default directory, C:\SITEMSTR, and begin the Setup routine.

- Step 5.** When the Setup program prompts, select “OK” or press the Enter key to restart Windows.

NOTE: The Setup routine will create a new Program Manager Group named “Site Master Software Tools.” This group will contain three file icons, “Read Me,” “Site Master Help,” and “Site Master Software Tools.”

- Step 6.** Double-click on the “Read Me” icon to read about (1) recent changes that did not get into this manual and/or (2) important features or problems that you should know about.
- Step 7.** Double-click on the “Site Master Help” icon to acquaint yourself with the comprehensive on-line manual. This manual provides descriptive narrative for the various program features and controls.
- Step 8.** Double-click on the “Site Master Software Tools” icon to open the Software Tools program.
- Step 9.** Click on Settings, in the top menu bar, and select COM Port. Enter the appropriate COM port number for the serial interface cable (null modem type).

Plot Capture

Plots (traces) can be captured either singly from the **Site Master** display or in multiples from one or more stored-display locations. Both methods are described below.

The recommended method is the **Capture Multiple Traces** option in the **Capture** pull-down menu. Using this method, you can download to the Software Tools program in one operation all of the data residing in the up-to-70 Stored Display memory locations. The downloaded traces will appear in a database or in cascade on the PC screen.

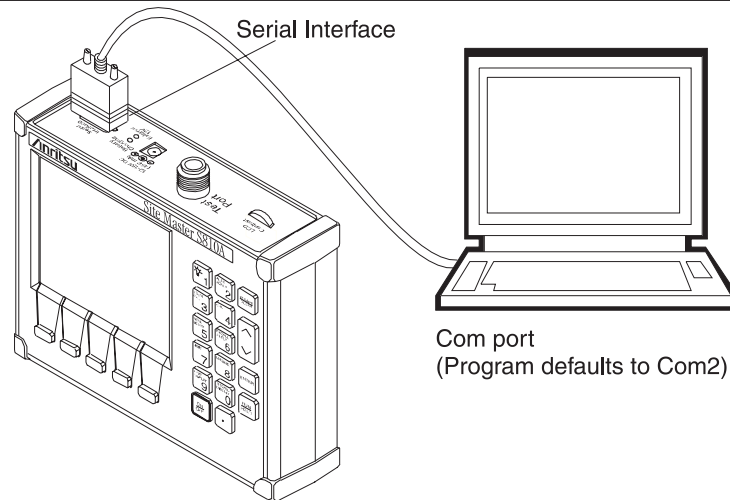

Figure 3-3. Equipment Setup for Site Master Tools Operation

NOTE: Trace scale can be captured as per **Site Master** or as autoscale by the capture program. To select per **Site Master** or autoscaling, click on **Settings** and **Default Plot Settings** from the top menu bar and pull-down menu.

Capture multiple to database

- Step 1.** Connect the supplied cable as shown in Figure 3-3.
- Step 2.** Open the “**Site Master Software Tools**” group, in the Windows Program Manager.
(Select the **Windows** pull-down menu from the Program Manager menu bar, and select **Site Master Software Tools**.)
- Step 3.** Double-click on the “**Site Master Software Tools**” icon to open the program.
- Step 4.** Click on **Capture**, in the top menu bar, and select **Capture Multiple To Database** from the drop-down menu.

- Step 5.** Follow the database instructions to download the plot(s) to either a new database or an existing database.
- Step 6.** Enter the number(s) of the stored-display memory location(s) (1 to 70) from which you wish to store to the database, and click “OK.”
- Step 7.** Observe that the “Acquiring Control” box appears on the screen, then disappears as traces are automatically acquired. The “Database” box appears when the plot(s) has been completely captured into the database.

Capture multiple traces to PC screen

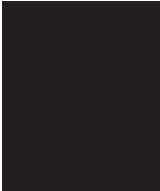
- 
- Step 1.** Perform steps 1, 2, and 3 of the capture-multiple-to-database procedure.
 - Step 2.** Click on “**Capture Multiple Traces**” icon or click on **Capture**, in the top menu bar, and select **Capture Multiple Traces** from the drop-down menu.
 - Step 3.** Enter the number (or numbers) of the stored-display memory location(s) (1 to 70) from which you wish to display traces in **Site Master Software Tools**.
 - Step 4.** Select “OK.”
 - Step 5.** Observe that the “Acquiring Control” box appears on the screen, then disappears as the traces are automatically acquired.

Single trace capture

- Step 1.** Perform steps 1, 2, and 3 of the capture-multiple-to-database procedure.
- Step 2.** Click on “**Start a Plot Capture**” icon or click on **Capture**, in the top menu bar, and select **Start Capture** from the drop-down menu.

3 - 8

Chapter 3 Screen Capture Program

- Step 3.** Observe that a “Waiting for Data” box appears on the screen.
- Step 4.** On the **Site Master**,
- Capture a new trace and store it to a memory location.
 - Recall the stored plot to the screen.
 - Press the ENTER key (on the **Site Master**) to start the screen capture.

*NOTE: The ENTER key on the **Site Master** must be pressed while the PC screen shows “Waiting for Data” for the transfer of information to be complete.*

- Step 5.** On the PC, observe that the “Waiting for Data” box disappears and the trace capture process begins. Within a short time, the **Site Master** trace will appear.

Program Operation

The captured trace on the PC can be scaled and have its limit line, markers, and properties changed. (Select **Plot Properties** under the **View** menu to make these changes.) The operation of the various menus that allow these operations to be accomplished is straightforward. To read about the operation of the menus, refer to the on-line help screens. They can be accessed from the **Help** menu, in the top menu bar.



Fault Location Software

A captured RL or SWR trace can be transformed to a Distance to Fault display. This is useful for determining the location of faults, connections, and other discontinuities within the cable.

To transform a plot, select **Fault Find** from the **Tools** menu (or click the toolbar button). A drop down menu will appear that asks you if the DUT is coaxial cable or waveguide. If coaxial cable, it asks you to supply start and stop distances along with propagation velocity and insertion loss values. If waveguide, it asks you to supply start and stop distances along with cutoff frequency and insertion loss values. Tables in Appendix A provide these values for some of the more popular coaxial cables and waveguides. If values are needed at a different frequency, or if you need the exact values for more accurate measurement, please contact the coaxial cable or waveguide manufacturer. Coaxial cables may be added to the list by editing the `cables.lst` file; waveguides may be added to the list by editing the `wvguides.lst` file. Follow the existing format to enter the data to the list. The distance may be entered in feet or meters. Propagation velocity or dielectric constant may be used for coaxial cable. The units may be changed by selecting **Default Plot Settings** under the **Settings** menu and changing “Distance Units.”

After supplying the needed information and clicking OK, a new plot will open showing coax/waveguide match vs. distance.

Smith Chart Software

After obtaining a frequency SWR or RL plot on the computer display, click the Smith Chart icon. Read the Help file to see how this feature functions (under Smith Chart and Data Readout).

Saving a Plot as a Windows Metafile

Plots can be saved as Windows Metafiles (.WMF). The metafile may be imported into other graphic programs, but cannot be reloaded into the Site Master Software Tools program.

To save a plot as a Windows Metafile, click on **File**, in the top menu bar, and select **Save as Metafile** from the drop down menu.

Saving Data to a Spreadsheet

The data points from a plot can be exported to a spreadsheet via the clipboard. To transfer data to a Windows spreadsheet program:

- Step 1.** Select **Settings** and **Clipboard Format** from the top menu bar and pull-down menu and choose **Formatted Text**.
- Step 2.** Capture or load the desired plot.
- Step 3.** Copy the data to the clipboard by selecting the “**Copy to Clipboard**” icon or **Copy** from the Edit menu.
- Step 4.** Open the spreadsheet program and place the cursor where the first data point should appear.
- Step 5.** Select **Paste** from the spreadsheet program’s Edit menu.



Saving Data to a Data Base

Plots can be saved to a database. Comments can be added to the plot data saved. Queries of the data base provide a means of comparing plots in the data base. Refer to the on-line help screens for operating instructions.

To save a plot to a database, click on **File**, in the top menu bar, and select **Save Plot to Database** from the drop-down menu.

“Drag-n-Drop”

Site Master Software Tools is Windows based. Graphs can “Drag-n-Drop” onto each other. **Site Master Software Tools** allows quick comparison of “before” and “after” Distance-To-Fault measurements. Recent data is compared to a historical PC database record, which is usually recorded during site installation/commissioning.

Each cable/antenna tends to have a unique Distance-To-Fault (DTF) “Signature” because differing cable electrical lengths, cable types, dielectric thickness variations, and the positions of components (connectors, adapters, and lightning arrestors) will cause different reflections at differing positions in the transmission line. Variations in the “signature” between maintenance intervals offer a good indication of damage or damage causing conditions.

Printing

Captured traces may be printed from a PC using **Site Master** Software Tools. Once a captured trace has been downloaded choose **Print** under the **File** menu for printing options. The printer setup can be altered, plots can be scaled, and multiple plots can be printed from the Print dialog box.

Appendix A

Reference Data

Description

The following pages contain tables of waveguide and coaxial cable reference data that are necessary for proper operation of the **Site Master**. The data tables are organized as follows:

Table	Title	Page
A-1	Universal Waveguide Calibration Component Part Numbers	A-2
A-2	Coaxial to Universal Waveguide Adapters	A-3
A-3	Flange Compatibility	A-5
A-4	Waveguide Offset Short Specifications	A-8
A-5	Waveguide Technical Data	A-9
A-6	Coaxial Cable Technical Data	A-11



Appendix A Reference Data

Table A-1. Universal Waveguide Calibration Component Part Numbers

% Offset Short	% Offset Short	Precision Load	Tunable Load	Flange Type
23UM40	24UM40	26UM40	26UM40T	UnivM-229
23UM48	24UM48	26UM48	26UM48T	UnivM-187
23UM58	24UM58	26UM58	26UM58T	UnivM-159
23UM70	24UM70	26UM70	26UM70T	UnivM-137
23UM84	24UM84	26UM84	26UM84T	UnivM-112
23UM100	24UM100	26UM100	26UM100T	UnivM-90
23UM120	24UM120	26UM120	26UM120T	UnivM-75
23UM140	24UM140	26UM140	26UM140T	UnivM-62
23UM220	24UM220	26UM220	26UM220T	UnivM-42
23UA229	24UA229	26UA229	26UA229T	UnivUS-229
23UA187	24UA187	26UA187	26UA187T	UnivUS-187
23UA159	24UA159	26UA159	26UA159T	UnivUS-159
23UA137	24UA137	26UA137	26UA137T	UnivUS-137
23UA112	24UA112	26UA112	26UA112T	UnivUS-112
23UA90	24UA90	26UA90	26UA90T	UnivUS-90
23UA75	24UA75	26UA75	26UA75T	UnivUS-75
23UA62	24UA62	26UA62	26UA62T	UnivUS-62
23UA42	24UA42	26UA42	26UA42T	UnivUS-42
23CMR229	24CMR229	26CMR229	26CMR229T	CMR229
23CMR187	24CMR187	26CMR187	26CMR187T	CMR187
23CMR159	24CMR159	26CMR159	26CMR159T	CMR159
23CMR137	24CMR137	26CMR137	26CMR137T	CMR137
23CMR112	24CMR112	26CMR112	26CMR112T	CMR112
23CMR90	24CMR90	26CMR90	26CMR90T	CMR90
23UER40	24UER40	26UER40	26UER40T	UER40
23UER48	24UER48	26UER48	26UER48T	UER48
23UER58	24UER58	26UER58	26UER58T	UER58
23UER70	24UER70	26UER70	26UER70T	UER70
23UER84	24UER84	26UER84	26UER84T	UER84
23UER100	24UER100	26UER100	26UER100T	UER100

Appendix A Reference Data

Table A-2. Coaxial to Universal Waveguide Adapters (1 of 2)

Coaxial Adapter P/N	Start Frequency (GHz)	Stop Frequency (GHz)	Flange Type	Coaxial Connector	Waveguide Type
35UM40N	3.300	4.900	UnivM-229	Nm	WR229 WG11A
35UM48N	3.950	5.850	UnivM-187	Nm	WR187 WG12
35UM58N	4.900	7.050	UnivM-159	Nm	WR159 WG13
35UM70N	5.850	8.200	UnivM-137	Nm	WR137 WG14
35UM84N	7.050	10.000	UnivM-112	Nm	WR112 WG15
35UM100N	8.200	12.400	UnivM-90	Nm	WR90 WG16
35UM120N	10.000	15.000	UnivM-75	Nm	WR75 WG17
35UM140N	12.400	18.000	UnivM-62	Nm	WR62 WG18
35UM220K	17.000	26.500	UnivM-42	Km	WR42 WG20
35UA229N	3.300	4.900	UnivUS-229	Nm	WR229 WG11A
35UA187N	3.950	5.850	UnivUS-187	Nm	WR187 WG12
35UA159N	4.900	7.050	UnivUS-159	Nm	WR159 WG13
35UA137N	5.850	8.200	UnivUS-137	Nm	WR137 WG14
35UA112N	7.050	10.000	UnivUS-112	Nm	WR112 WG15
35UA90N	8.200	12.400	UnivUS-90	Nm	WR90 WG16
35UA75N	10.000	15.000	UnivUS-75	Nm	WR75 WG17
35UA62N	12.400	18.000	UnivUS-62	Nm	WR62 WG18
35UA42K	17.000	26.500	UnivUS-42	Km	WR42 WG20
35CMR229N	3.300	4.900	CMR229	Nm	WR229 WG11A
35CMR187N	3.950	5.850	CMR187	Nm	WR187 WG12
35CMR159N	4.900	7.050	CMR159	Nm	WR159 WG13



Appendix A Reference Data

Table A-2. Coaxial to Universal Waveguide Adapters (2 of 2)

Coaxial Adapter P/N	Start Frequency (GHz)	Stop Frequency (GHz)	Flange Type	Coaxial Connector	Waveguide Type
35CMR137N	5.850	8.200	CMR137	Nm	WR137 WG14
35CMR112N	7.050	10.000	CMR112	Nm	WR112 WG15
35CMR90N	8.200	12.400	CMR90	Nm	WR90 WG16
35UER40N	3.300	4.900	UER40	Nm	WR229 WG11A
35UER48N	3.950	5.850	UER48	Nm	WR187 WG12
35UER58N	4.900	7.050	UER58	Nm	WR159 WG13
35UER70N	5.850	8.200	UER70	Nm	WR137 WG14
35UER84N	7.050	10.000	UER84	Nm	WR112 WG15
35UER100N	8.200	12.400	UER100	Nm	WR90 WG16



Appendix A Reference Data

Table A-3. Universal Flange Compatibility (1 of 3)

Calibration Component P/N	Start Frequency (GHz)	Stop Frequency (GHz)	Waveguide Type	Flange Type	Compatible Flanges
xxUM40	3.300	4.900	WR229 WG11A	UnivM-229	PDR40
xxUM48	3.950	5.850	WR187 WG12	UnivM-187	CAR48 PAR48 UAR48 PDR48
xxUM58	4.900	7.050	WR159 WG13	UnivM-159	CAR58 PAR58 UAR58 PDR58
xxUM70	5.850	8.200	WR137 WG14	UnivM-137	CAR70 PAR70 UAR70 PDR70
xxUM84	7.050	10.000	WR112 WG15	UnivM-112	CBR84 UBR84 PBR84 PDR84
xxUM100	8.200	12.400	WR90 WG16	UnivM-90	CBR100 UBR100 PBR100 PDR100
xxUM120	10.000	15.000	WR75 WG17	UnivM-75	CBR120 UBR120 PBR120 PDR120
xxUM140	12.400	18.000	WR62 WG18	UnivM-62	CBR140 UBR140 PBR140 PDR140
xxUM220	17.000	26.500	WR42 WG20	UnivM-42	CBR220 UBR220 PBR220 PDR220
xxUA229	3.300	4.900	WR229 WG11A	UnivUS-229	CPR229F CPR229G UG-1350/U UG-1351/U UG-1726/U UG-1727/U
xxUA187	3.950	5.850	WR187 WG12	UnivUS-187	CPR187F CPR187G UG-1352/U UG-1353/U UG-1728/U UG-1729/U UG-148/U UG-149A/U



Appendix A Reference Data

Table A-3. Universal Flange Compatibility (2 of 3)

Calibration Component P/N	Start Frequency (GHz)	Stop Frequency (GHz)	Waveguide Type	Flange Type	Compatible Flanges
xxUA159	4.900	7.050	WR159 WG13	UnivUS-159	CPR159F CPR159G UG-1354/U UG-1355/U UG-1730/U UG-1731/U
xxUA137	5.850	8.200	WR137 WG14	UnivUS-137	CPR137F CPR137G UG-1356/U UG-1357/U UG-1732/U UG-1733/U UG-343B/U UG-344/U UG-440B/U UG-441/U
xxUA112	7.050	10.00	WR112 WG15	UnivUS-112	CPR112F CPR112G UG-1358/U UG-1359/U UG-1734/U UG-1735/U UG-52B/U UG-51/U UG-137B/U UG-138/U
xxUA90	8.200	12.400	WR90 WG16	UnivUS-90	CPR90F CPR90G UG-1360/U UG-1361/U UG-1736/U UG-1737/U UG-40B/U UG-39/U UG-135/U UG-136B/U
xxUA75	10.000	15.000	WR75 WG17	UnivUS-75	WR75
xxUA62	12.400	18.000	WR62 WG18	UnivUS-62	UG-541A/U UG-419/U UG-1665/U UG-1666/U
xxUA42	17.000	26.500	WR42 WG20	UnivUS-42	UG-596A/U UG-595/U UG-597/U UG-598A/U
xxCMR229	3.300	4.900	WR229 WG11A	CMR229	CMR229
xxCMR187	3.950	5.850	WR187 WG12	CMR187	CMR187 UG-1475/U UG-1480/U

A-6

Appendix A Reference Data

Table A-3. Universal Flange Compatibility (3 of 3)

Calibration Component P/N	Start Frequency (GHz)	Stop Frequency (GHz)	Waveguide Type	Flange Type	Compatible Flanges
xxCMR159	4.900	7.050	WR159 WG13	CMR159	CMR159
xxCMR137	5.850	8.200	WR137 WG14	CMR137	CMR137 UG-1476/U UG-1481/U
xxCMR112	7.050	10.000	WR112 WG15	CMR112	CMR112 UG-1477/U UG-1482/U
xxCMR90	8.200	12.400	WR90 WG16	CMR90	CMR90 UG-1478/U UG-1483/U
xxUER40	3.300	4.900	WR229 WG11A	UER40	UER40
xxUER48	3.950	5.850	WR187 WG12	UER48	UER48
xxUER58	4.900	7.050	WR159 WG13	UER58	UER58
xxUER70	5.850	8.200	WR137 WG14	UER70	UER70
xxUER84	7.050	10.000	WR112 WG15	UER84	UER84
xxUER100	8.200	12.400	WR90 WG16	UER100	UER100



Appendix A Reference Data

Table A-4. Waveguide Offset Short^① Specifications

Offset Short P/N	Frequency (GHz)	Length (mm)
24UM40	4.021	36,419 ±.14
24UM48	4.807	30,979 ±.11
24UM58	5.878	24,664 ±.09
24UM70	6.926	20,710 ±.08
24UM84	8.396	17,040 ±.05
24UM100	10.084	14,675 ±.05
24UM120	12.247	11,978 ±.04
24UM140	14.940	9,742 ±.04
24UM220	21.225	7,067 ±.03
24UA229	4.021	36,419 ±.14
24UA187	4.807	30,979 ±.11
24UA159	5.878	24,664 ±.09
24UA137	6.926	20,710 ±.08
24UA112	8.396	17,040 ±.05
24UA90	10.084	14,675 ±.05
24UA75	12.247	11,978 ±.04
24UA62	14.940	9,742 ±.04
24UA42	21.225	7,067 ±.03
24CMR229	4.021	36,419 ±.14
24CMR187	4.807	30,979 ±.11
24CMR159	5.878	24,664 ±.09
24CMR137	6.926	20,710 ±.08
24CMR112	8.396	17,040 ±.05
24CMR90	10.084	14,675 ±.05
24UER40	4.021	36,419 ±.14
24UER48	4.807	30,979 ±.11
24UER58	5.878	24,664 ±.09
24 UER70	6.926	20,710 ±.08
24UER84	8.396	17,040 ±.05
24UER100	10.084	14,675 ±.05

^① Offset Shorts are $\frac{1}{8}$ wave at the geometric mean frequency of the waveguide band; dimensionally accurate to <0.5 degree at the maximum operating frequency of the corresponding waveguide.

Appendix A Reference Data

Table A-5. Waveguide Technical Data (1 of 2)

Waveguide Type/Model	Start Frequency (GHz)	Stop Frequency (GHz)	Cutoff Frequency (GHz)	Mid-Band Loss (dB/ft, GHz)
WR229 WG11A	3.300	4.900	2.577	0.0114
WR187 WG12	3.950	5.850	3.156	0.0157
WR159 WG13	4.900	7.050	3.705	0.0180
WR137 WG14	5.850	8.200	4.285	0.0225
WR112 WG15	7.050	10.000	5.260	0.0312
WR102	7.000	11.000	5.786	0.0330
WR90 WG16	8.200	12.400	6.560	0.0481
WR75 WG17	10.000	15.000	7.847	0.0583
WR67	11.000	17.000	8.578	0.0658
WR62 WG18	12.400	18.000	9.490	0.0735
WR51	15.000	22.000	11.540	0.1125
WR42 WG20	17.000	26.500	14.080	0.1585
Andrew				
EW34	3.100	4.200	2.376	0.0068
EW37	3.300	4.300	2.790	0.0089
EW43	4.400	5.000	2.780	0.0088
EW52	4.600	6.425	3.650	0.0120
EW63	5.580	7.125	4.000	0.0138
EW64	5.300	7.750	4.320	0.0146
EW77	6.100	8.500	4.720	0.0178
EW85	7.700	9.800	6.460	0.0331
EW90	8.300	11.700	6.500	0.0308
EW127	10.000	13.250	7.670	0.0385
EW132	11.000	15.350	9.220	0.0482
EW180	14.000	19.700	11.150	0.0591
EW220	17.000	23.600	13.340	0.086



Appendix A Reference Data

Table A-5. Waveguide Technical Data (2 of 2)

Waveguide Type/Model	Start Frequency (GHz)	Stop Frequency (GHz)	Cutoff Frequency (GHz)	Mid-Band Loss (dB/ft, GHz)
Cablewave				
WE37	3.600	4.200	2.830	0.0082
WE46	4.400	5.000	3.000	0.0108
WE61	5.925	6.425	3.600	0.0119
WE65	6.425	7.125	4.000	0.0138
WE70	7.125	7.750	4.300	0.0123
WE78	7.125	8.500	4.670	0.0136
WE108	10.500	11.700	6.570	0.0298
WE130	11.700	13.250	7.430	0.0348
WE150	14.000	15.350	8.600	0.0426
WE191	17.700	19.700	10.680	0.0595
Hanover				
E38	3.100	4.200	2.320	0.0074, 3.6
EH46	4.400	5.000	3.080	0.0110
E54	5.000	6.000	3.870	0.0143, 5.4
E60	5.600	6.425	3.600	0.0108
E65	5.925	7.125	3.990	0.0139
E70	6.425	7.750	4.290	0.0146
EH78	7.700	8.500	4.650	0.0211, 8.2
E100	8.500	10.000	6.440	0.0271, 9.5
E105	10.700	11.700	6.600	0.0277
E130	10.950	13.250	8.400	0.0344
E150	14.000	15.350	10.490	0.0422
E185	17.300	19.700	11.100	0.0588
E220	21.200	23.600	12.900	0.0915, 22.5

Appendix A Reference Data

Table A-6. Coaxial Cable Technical Data

Cable Type	Maximum Frequency (GHz)	Relative Propagation Velocity (V_r)	Nominal Attenuation dB/100 ft @ 6 GHz
FSJ1-50A	20.4	0.84	16.2
FSJ2-50	13.4	0.83	11.4
FSJ4-50B	10.2	0.81	10.6
EFX2-50	13.5	0.85	10.4
LDF1-50	15.8	0.86	9.34
LDF2-50	13.5	0.88	9.85
LDF4-50A	8.8	0.88	6.64
HJ4-50	10.9	0.914	7.84
HJ4.5-50	6.6	0.92	4.5



A-11/A-12



Anritsu

Color Cover P/N: 00986-00019