

**Anritsu** envision : ensure

# Wireless Connectivity Test Set

## MT8862A



H a v e y o u  
m e a s u r e d m e u p ?





# MT8862A

## Ideal for RF TRx Tests of WLAN Devices

Wireless communications over WLAN are increasing rapidly due to the widespread use of mobile terminals, such as smartphones, as well as integration of network-connected TVs, cleaners, automobiles, industrial equipment, sensors, and more, into the Internet of things (IoT). Makers of these equipment are anticipating more end-user enquiries related to WLAN performance, including network coverage, reception sensitivity, etc.

Anritsu's Wireless Connectivity Test Set is ideal for measuring the RF TRx characteristics at design and manufacturing inspection of WLAN devices. It has a built-in Network Mode for measuring the performance of the WLAN DUT under realistic operation conditions to play a key role in quality evaluation and improvement.

11ax

### Supports Latest Standards

As well as supporting IEEE802.11a/b/g/n/ac, the MT8862A supports the latest WLAN IEEE802.11ax standard to evaluate a broader range of WLAN-device RF TRx characteristics including Tx power, Rx sensitivity, and more.

Network Mode

### Measurement under Realistic Operation Conditions

The MT8862A uses standard WLAN protocol messaging with a built-in Network Mode to establish a connection with the WLAN device and measure the RF TRx characteristics under realistic operation conditions. Also the MT8862A supports Direct Mode.



Smartphone  
Tablet



Smart appliances



Wearable device



Gateway



Automotive



Smart grid

# Wireless Connectivity Test Set MT8862A

## RF TRx Measurements of WLAN Equipment

The Wireless Connectivity Test Set MT8862A is designed for measuring the RF TRx characteristics of WLAN equipment. It has standard WLAN protocol messaging (WLAN signalling) to connect with the device under test (DUT) for measuring the TRx performance items as Network Mode. It is the biggest feature of MT8862A. MT8862A gives manifold inspections for WLAN equipment because it also supports Direct Mode.

## Supported Communications Standards • Security encryption

WLAN IEEE802.11a/b/g/n/ac/ax (2.4 GHz and 5 GHz bands) [AP/STA]  
WEP, WPA-Personal, and WPA2-Personal



Wireless Connectivity Test Set  
**MT8862A**

## RF Performance Measurement under Actual Operation Conditions (Network Mode)

By using the MT8862A Network Mode, RF TRx characteristics, such as Tx power, modulation accuracy (EVM), etc., can be measured with the WLAN device in actual operation conditions. It is not necessary to put the DUT into dedicated test mode and directly control the DUT. The DUT RF performance can be quantified under the firmware conditions at actual shipment.

## Easy Measurement Environment Configuration

The MT8862A can simulate access points (AP) and station (STA) to establish the DUT network connection using IEEE802.11a/b/g/n/ac/ax WLAN protocol messaging. Each WEP, WPA-Personal and WPA2-Personal secure connection method is supported, and TKIP and AES encryption schemes can be selected by combination with each standard. When the connection is established, RF measurements can be made using general WLAN communications procedures without requiring special tools and control procedures, eliminating the need for configuring a special measurement environment.

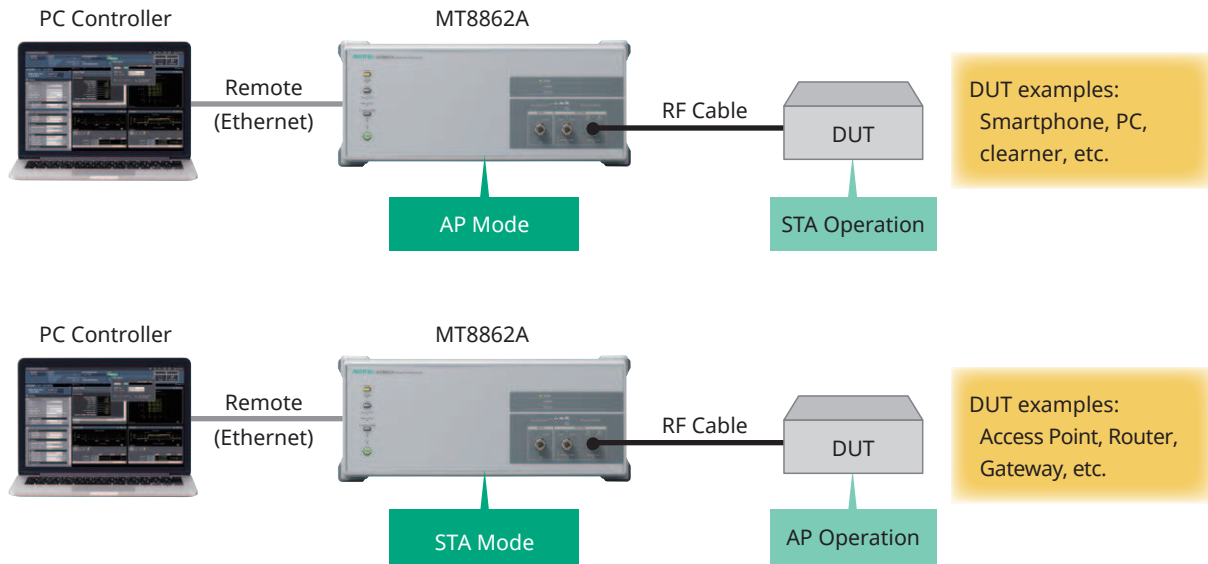



# WLAN Measurement Software MX886200A Features

## ICMP Echo Request for Tx Measurement

With the ICMP echo request, the MT8862A can measure RF Tx characteristics of reply packets from the DUT. The measurement targets are both data frames and ACK frames.

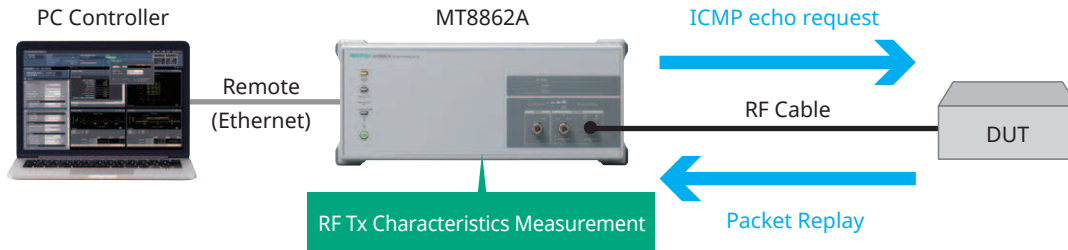

## Rx Sensitivity Measurements using ACK Frame Count for Bathtub Curve Generation

The MT8862A supports Rx sensitivity measurements using the ACK frame count; counting the ACK frames sent by the DUT versus the test packets sent from the MT8862A supports calculation of the packet error rate (PER). Packets can be sent while lowering the power level by setting the power level range (0 to -120 dBm) and step size, and the Rx sensitivity Bathtub curve can be generated automatically. Packets including MAC address and payload length can be configured in real-time for measurement at various data rates.

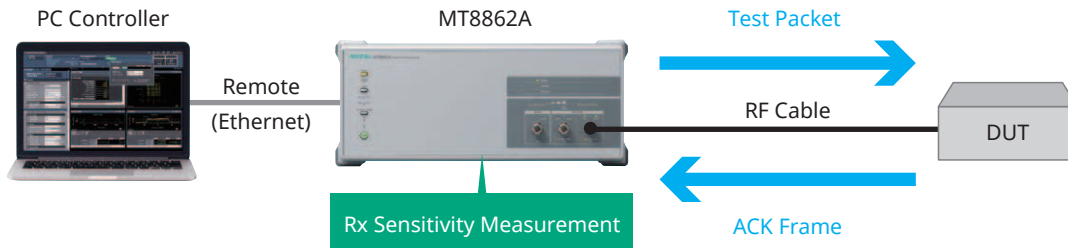

## Web Browser GUI Operation Immediately after Connection

Connect the MT8862A to the external PC using an Ethernet cable for instant access from the Web browser to complete setup of the GUI operation environment without requiring test setup operation.

The Web-browser based GUI eliminates usage worries about version matching with the main frame firmware. Additionally, the MT8862A remote control port supports the DHCP client function and both host and domain name settings offer easy control simply by connecting the PC controller and MT8862A to the same network.

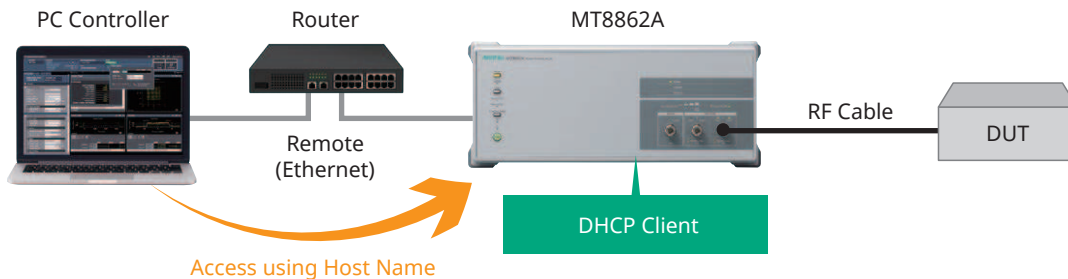

# WLAN Measurement Software MX886200A Features

## Function Test

### Frame Capture Logging for Troubleshooting Connection Problems

With built-in frame capture logging function, the MT8862A can capture and save frame logs for troubleshooting DUT connection problems. Captured logs are in the \*.pcap format for viewing by supported applications, making it easier to analyze DUT connection problems.

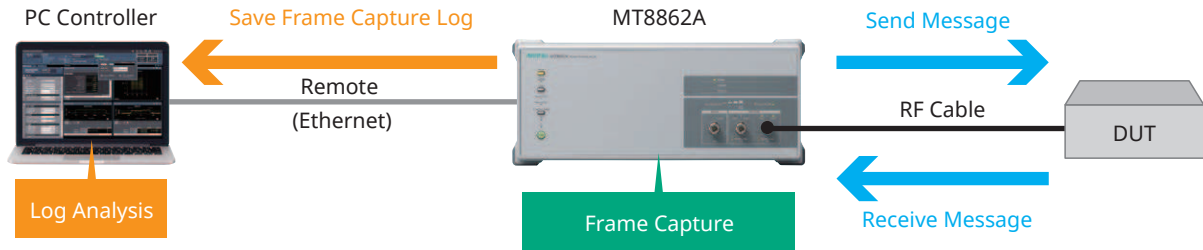

### IP Data Transfer using Connection Verification Test

The Ethernet port on the back panel of the MT8862A can be used for exchanging IP data with an external server; IP connections between the client PC connected to the DUT and the external server connected to the MT8862A can be checked using the ping function, etc.

\* This function does not support MIMO, does not support 802.11ax.

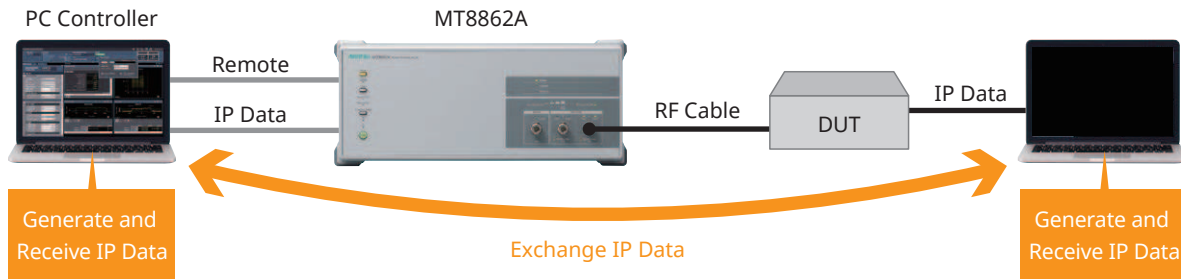

### Receiver Sensitivity and Transmit Power Measurement Function for 2x2 MIMO

Receiver sensitivity and transmit power measurement under 2x2 MIMO communication can be tested by using 2 sets of MT8862A. This is suitable for RF performance evaluation for completed products.

\* This function supports IEEE802.11n/ac only.

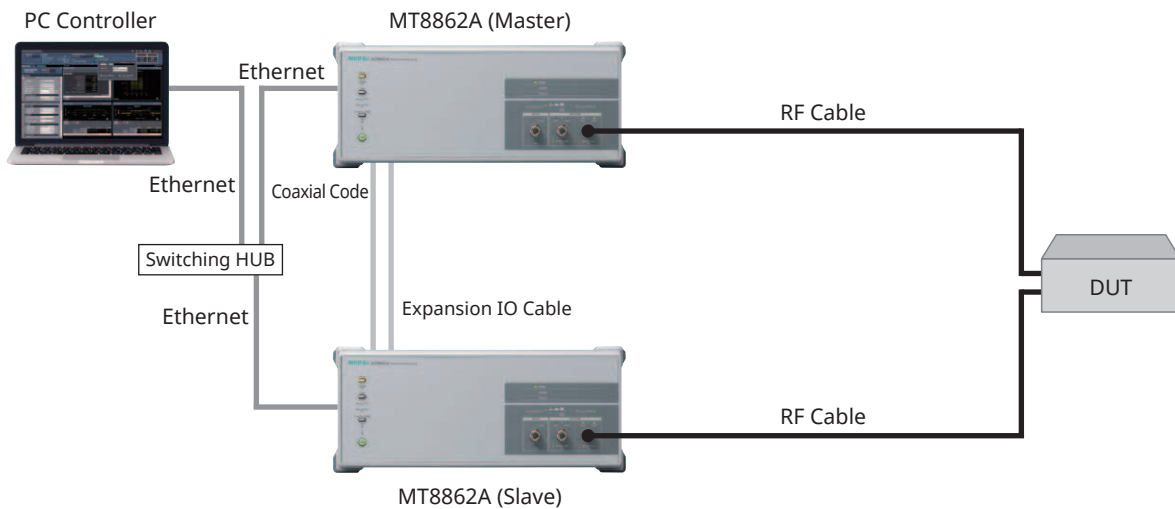

# WLAN Measurement Software MX886200A Features

## Application Test

### Network Mode for Over The Air (OTA) Test

The TRx performance of wireless terminals is affected by factors such as the terminal form and antenna characteristics. The OTA test measures the general TRx performance of the wireless terminal using actual radio waves. The WLAN OTA test measures RF performance specifications in accordance with the recommendations of CTIA\* and the Converged Wireless Group (CWG) of the Wi-Fi Alliance, including Total Radiated Power (TRP), Total Isotropic Sensitivity (TIS), System integrators have test solution using MT8862A.

\*: Cellular Telecommunications & Internet Association; international non-profit organization composed of wireless-communications-related businesses, manufacturers, service providers, etc.

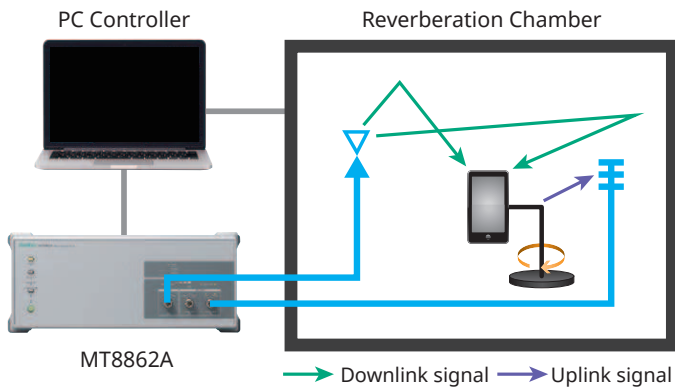
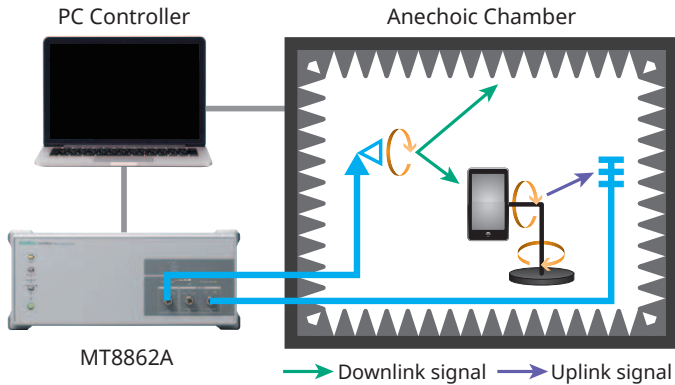

### Auto-ID information display

MT8862A displays header information of packets used for transmit measurement as Auto-ID Information.

Auto-ID Information	
Auto-ID Standard	AC
Guard Interval	LONG
PPDU Type	VHT80
MCS Index	9
Coding Type	BCC
PSDU Length	1096
L-SIG Parity Status	PASS
VHT-SIG CRC	PASS
Number of Space Time Streams	2
STBC	0

# WLAN Measurement Software MX886200A Key Functions

## RF Tx Test

### Tx Power Measurement and Power Profile Display

The MT8862A measures the Tx power and displays the average and peak power. The crest factor indicating the difference between the average power and peak power and the power-on ramp time and power-off ramp time indicating the time of ringing and falling are also displayed. The power profile is displayed as a graph of the power vs time for the signal.

Output Power Measurements

Transmit Power			
	Average	Maximum	Minimum
Gate1 Average Power [dBm]	0.38	0.38	0.38
Gate1 Peak Power [dBm]	9.21	9.21	9.21

Crest Factor			
	Average	Maximum	Minimum
Gate1 [dB]	8.83	8.83	8.83

Power Ramp			
	Average	Maximum	Minimum
Power-on Ramp Time [us]	0.09	0.09	0.09
Power-down Ramp Time [us]	0.11	0.11	0.11



### Frequency and Modulation Analysis/IQ Constellation Display/Spectrum Display

The MT8862A performs frequency and modulation analyses to measure the Error Vector Magnitude (EVM), which is a good of overall indicator of transmitter quality. When the numerical EVM is bad, the Packet Error Rate (PER) is usually high at WLAN connection. The RMS EVM and Peak EVM for DSSS- and OFDM-modulated carrier waves are expressed as % and dB values, respectively.

In case of OFDM modulation, in addition to EVM, Center Frequency Leakage, Center Frequency Tolerance, Symbol Clock Frequency Tolerance, IQ Imbalance, and Spectral Flatness are also displayed. In case of DSSS modulation, in addition to EVM, Center Frequency Tolerance, IQ Offset, Phase & Magnitude Error, IQ Imbalance, Chip Clock Frequency Tolerance, and Carrier Suppression from IQ Offset are also displayed. Furthermore, the IQ constellation, spectrum flatness, and spectrum analysis results are displayed as graphs.

Frequency / Modulation Measurements

EVM			
	Average	Maximum	Minimum
RMS [dB]	-33.99	-33.99	-33.99
RMS [%]	2.00	2.00	2.00
Peak [dB]	-27.30	-27.30	-27.30
Peak [%]	4.32	4.32	4.32

Center Frequency Leakage			
	Average	Maximum	Minimum
Center Frequency Leakage [dB]	-41.21	-41.21	-41.21

Center Frequency Tolerance			
	Average	Maximum	Minimum
Center Frequency Tolerance [ppm]	0.3	0.3	0.3
Center Frequency Tolerance [Hz]	672	672	672

Symbol Clock Frequency Tolerance			
	Average	Maximum	Minimum
Symbol Clock Frequency Tolerance [ppm]	0.4	0.4	0.4
Symbol Clock Frequency Tolerance [Hz]	0	0	0

IQ Imbalance			
	Average	Maximum	Minimum
Amplitude Imbalance [dB]	0.07	0.07	0.07
Phase Imbalance [degrees]	-0.06	-0.06	-0.06
Phase Error [degrees]	0.39	0.39	0.39

Spectral Flatness: Pass / Fail **FAIL**



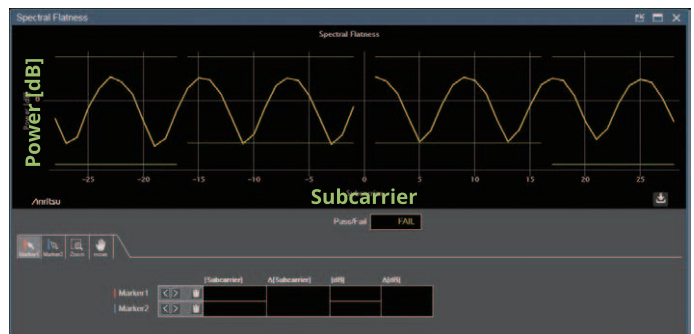
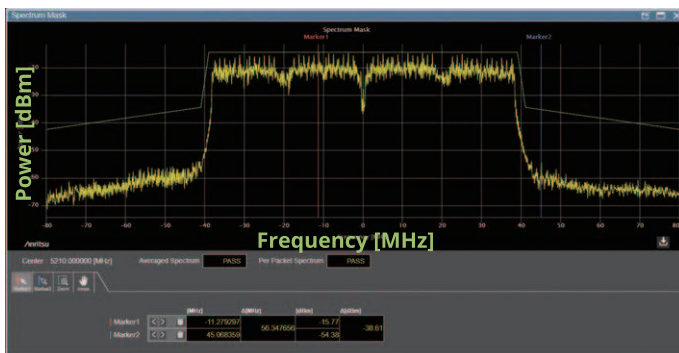
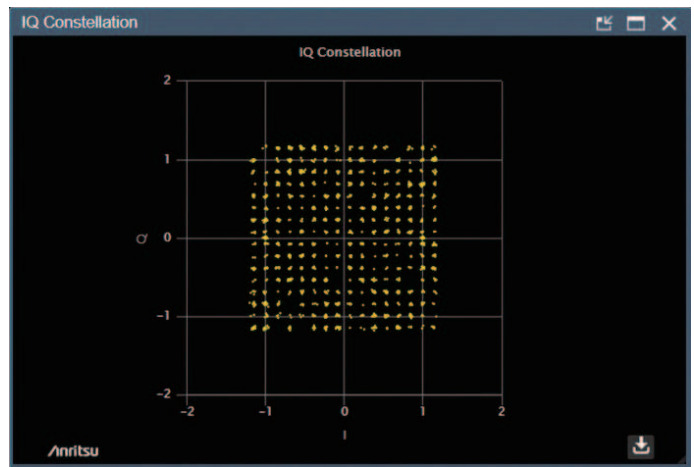

# WLAN Measurement Software MX886200A Key Functions

## RF Rx Test

### Packet Error Rate (PER)

The MT8862A Network Mode is a unique function that can use general communication method and instead automatically implements the 802.11a/b/g/n/ac/ax device sensitivity search measurement to output the Bathtub curve. By using this function, the device performance can be analyzed at high speed for each data rate, offering a convenient measurement solution for verifying compliance with the 802.11b minimum receiver sensitivity test specifications. This is a flexible test solution because the number of packets sent at each power level can be specified both as the start and stop search level and as step size.

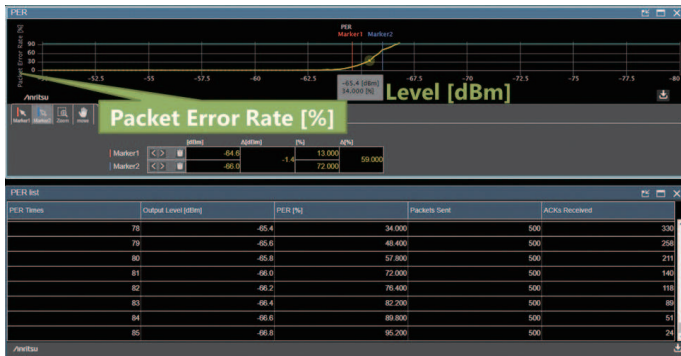

### Frame Rx rate (FRR)

The Frame Rx Rate can be displayed instead of displaying the Packet Rx Error Rate (PER).

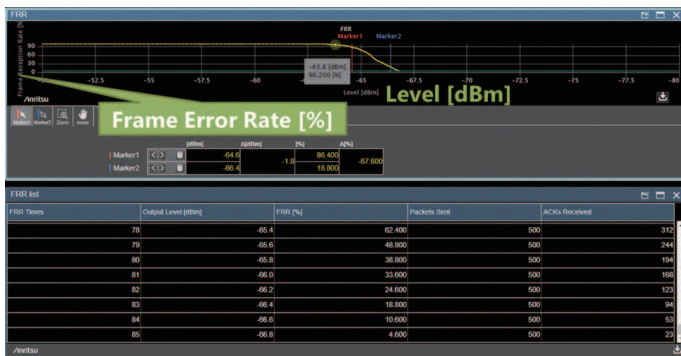

# WLAN Measurement Software MX886200A Key Functions

## Connectivity

	802.11a
Frequency Range	5180 MHz to 5825 MHz
Operation Mode	—
Modulation	OFDM (BPSK, QPSK, 16QAM, 64QAM)
Data Rate	6, 9, 12, 18, 24, 36, 48, 54 Mbps
Security*2	WEP, WPA-Personal, WPA2-Personal

	802.11b	802.11g
Frequency Range	2412 MHz to 2484 MHz	
Operation Mode	—	ERP-OFDM
Modulation	DSSS, CCK	OFDM (BPSK, QPSK, 16QAM, 64QAM)
Data Rate	1, 2, 5.5, 11 Mbps	6, 9, 12, 18, 24, 36, 48, 54 Mbps
Security*2	WEP, WPA-Personal, WPA2-Personal	

	802.11n	802.11ac*1
Frequency Range	2412 MHz to 2484 MHz and 5180 MHz to 5825 MHz	5180 MHz to 5825 MHz
Bandwidth	20 MHz, 40 MHz	20, 40, 80 MHz
MCS	MCS0 to MCS7, MCS0 to MCS15*3	MCS0 to MCS9*5
FEC	BCC	BCC
PPDU Format	HT-mixed, HT-greenfield*4	VHT
Guard Interval Type	Long, Short	Long, Short
RF Chain	Single (SISO), 2×2MIMO*3	Single (SISO), 2×2MIMO*3
Security*2	WPA-Personal, WPA2-Personal	

	802.11ax*6
Frequency Range	2412 MHz to 2484 MHz, 5180 MHz to 5825 MHz
Bandwidth	20 MHz, 40 MHz (2.4 GHz Bands) 20, 40, 80 MHz (5 GHz Bands)
MCS	MCS0 to MCS11
FEC	BCC, LDPC
PPDU Format	Tx measurement: HE SU, HE TB
Guard Interval Type	Rx measurement: HE SU
Guard interval and HE-LTF type	HE SU 0.8 μs GI, 1xHE-LTF 0.8 μs GI, 2xHE-LTF 1.6 μs GI, 2xHE-LTF 0.8 μs GI, 4xHE-LTF 3.2 μs GI, 4xHE-LTF HE TB 1.6 μs GI, 2xHE-LTF 3.2 μs GI, 4xHE-LTF
RF Chain	Single (SISO)
Security	WPA-Personal, WPA2 -Personal

\*1: 802.11ac connection requires MX886200A-001

\*2: Secure connections require the MX886200A-020

\*3: Available when measure 2×2MIMO receiver sensitivity using MX886200A-010.

\*4: Only receiver sensitivity testing is supported in 2×2MIMO.

\*5: MCS9 is only available on 40 MHz or 80 MHz bandwidth.

\*6: 802.11ax connection requires MX886200A-002

# WLAN Measurement Software MX886200A Measurement Items

## Tx Measurements

### Items by Standards

IEEE 802.11-2012: 802.11b

802.11b	Measurement Items
17.4.7.2	Transmit power levels
17.4.7.4	Transmit spectral mask
17.4.7.5	Transmit center frequency tolerance
17.4.7.6	Chip clock frequency tolerance
17.4.7.7	Transmit power-on and power-down ramp
17.4.7.9	Transmit modulation accuracy

IEEE802.11-2012: 802.11a/g/n Tx Measurements, IEEE802.11ac-2013: 802.11ac Tx Measurements\*1

802.11a	802.11g	802.11n	802.11ac	Measurement Items
18.3.9.2	19.4.8.2	20.3.20.3	N/A	Transmit power levels
18.3.9.3	19.5.5	20.3.20.1	22.3.18.1	Transmit spectrum mask*2
18.3.9.5	19.4.8.3	20.3.20.4	22.3.18.3	Transmit center frequency tolerance
18.3.9.6	19.4.8.4	20.3.20.6	22.3.18.2	Symbol clock frequency tolerance
18.3.9.7.2	18.3.9.7.2	20.3.20.7.2	22.3.18.4.2	Transmitter center frequency leakage
18.3.9.7.3	18.3.9.7.3	20.3.20.2	22.3.18.2	Transmitter spectral flatness
18.3.9.7.4	18.3.9.7.4	20.3.20.7.3	22.3.18.4.3	Transmitter constellation error
18.3.9.8	18.3.9.8	20.3.20.7.4	22.3.18.4.4	Transmitter modulation accuracy test

IEEE802.11ax/D4.0: 802.11ax Tx Measurements\*3

802.11ax	Measurement Items
27.3.14.3	Pre-correction accuracy requirements*4
27.3.18.1	Transmit spectral mask*5
27.3.18.2	Spectral flatness
27.3.18.3	Transmit center frequency and symbol clock frequency tolerance
27.3.18.4.2	Transmit center frequency leakage
27.3.18.4.3	Transmitter constellation error
27.3.18.4.4	Transmitter modulation accuracy (EVM) test

\*1: 802.11ac Tx measurement requires MX886200A-001

\*2: Frequency SPAN of 802.11ac supports up to ±80 MHz

\*3: 802.11ax Tx measurement requires MX886200A-002

\*4: Measure the error between DUT transmission power and TargetRSSI.

\*5: Frequency SPAN of 802.11ax supports up to ±80 MHz

### Measurement Items

MT8862A 11b Measurement Items
Transmit power
Crest factor
Power ramp
EVM (Transmit modulation accuracy)
Center frequency tolerance
IQ offset
Phase error
Magnitude error
Amplitude imbalance
Phase imbalance
Chip clock frequency tolerance
Carrier suppression from IQ offset
Spectrum mask

MT8862A 11a/g/n/ac Measurement Items
Transmit power
Crest factor
Power ramp
EVM (Transmit modulation accuracy)
Center frequency leakage
Center frequency tolerance
Symbol clock frequency tolerance
Amplitude imbalance
Phase imbalance
Phase error
Spectrum flatness
Spectrum mask

MT8862A 11ax HE SU (Single User) Measurement Items
Transmit power
Crest factor
Power ramp
EVM (Transmit modulation accuracy)
Center frequency leakage
Center frequency tolerance
Symbol clock frequency tolerance
Amplitude imbalance
Phase imbalance
Phase error
Spectrum flatness
Spectrum mask

MT8862A 11ax HE TB (Multi User) Measurement Items
Transmit power
Power pre-correction accuracy
Crest factor
Power ramp
EVM (Transmit modulation accuracy)
Unused tone error
Center frequency leakage
Center frequency tolerance
Center frequency offset
Amplitude imbalance
Phase imbalance
Phase error
Spectrum flatness
Spectrum mask

# WLAN Measurement Software MX886200A Measurement Items

## Tx Measurements

### Graph Display Items

MT8862A 11b Graph Display Items
IQ Constellation
Power Profile
Spectrum Mask

MT8862A 11a/g/n/ac Graph Display Items
IQ Constellation
Power Profile
Spectrum Mask
Spectrum Flatness

MT8862A 11ax Graph Display Items
IQ Constellation
Power Profile
Spectrum Mask
Spectrum Flatness
Carrier Frequency Offset Error (CCDF)□
Unused Tone Error

\*: Available on HETB format.

## Rx Measurements

### IEEE802.11-2012: 802.11b Rx Measurements

802.11b	Measurement Item
17.4.8.2	Receiver minimum input level sensitivity
17.4.8.3	Receiver maximum input level
17.4.8.4	Receiver adjacent channel rejection*1

### IEEE802.11-2012: 802.11a/g/n Rx Measurements; IEEE802.11ac-2013: 802.11ac Rx Measurements\*2

802.11a	802.11g	802.11n	802.11ac	Measurement Item
18.3.10.2	19.5.2	20.3.21.1	22.3.19.1	Receiver minimum input level sensitivity
18.3.10.3	19.5.3	20.3.21.2	22.3.19.2	Adjacent channel rejection*1
18.3.10.4	18.3.10.4	20.3.21.3	22.3.19.3	Nonadjacent channel rejection*1
18.3.10.5	19.5.4	20.3.21.4	22.3.19.4	Receiver maximum input level

### IEEE802.11ax/D4.0: 802.11ax Rx Measurements\*3

802.11ax	Measurement Item
27.3.19.2	Receiver minimum input sensitivity
27.3.19.3	Adjacent channel rejection*1
27.3.19.4	Nonadjacent channel rejection*1
27.3.19.5	Receiver maximum input level

### Graph Display

Measurement Item
Packet Error Rate (PER)
Frame Reception Rate (FRR)

\*1: Sold separately; requires signal generator

\*2: 802.11ac Rx measurement requires MX886200A-001

\*3: 802.11ax Rx measurement requires MX886200A-002

## Wireless Connectivity Test Set MT8862A Configuration

### System Configurations/Options/Software/PC Controller Operation Environment

System	Wireless LAN
Main Frame	Wireless Connectivity Test Set MT8862A
Basic Configuration (Hardware)	RF Frequency 2.4 GHz, 5 GHz MT8862A-001
Basic Configuration (Software)	WLAN Measurement Software MX886200A
Options	WLAN 802.11ac Option MX886200A-001 WLAN 802.11ax Option MX886200A-002 2x2MIMO Measurement Software MX886200A-010 WLAN Security Function MX886200A-020

#### Verified PC Operation Environment

PC	Software OS: Windows 10 Browser: Chrome CPU: Intel Core i5 processor Clock: 2.5 GHz Memory: 1 GB minimum Hard Disk: 500 MB minimum free space LAN: 100 Base-T LAN (1000-base T preferred)
Peripherals	Display: WXGA 1024 × 768 minimum



# Wireless Connectivity Test Set MT8862A Panel Layout

## Front Panel



**1 Power switch**

Turns the power On or Off.  
Off: Power is Off, Green: Power is On.

**2 Standby lamp**

The power is supplied to the AC inlet and the power switch can be turned On.

**3 Access lamp**

Green: Accessing the built-in storage device.

**4 IP Address Reset key**

Long-pressing this switch resets the network settings such as IP address to defaults.

**5 External Ref. lamp**

Indicates status of external reference signal.

**6 System Error lamp**

Indicates errors of the unit.

**7 Local key**

Reset the remote control state by Ethernet to local and enable panel setting.

**8 Remote lamp**

Off: Local control.  
Green: Remote control.

**9 Preset key**

Long-pressing this switch resets the parameter settings to defaults.

**10 Ready lamp/Connect lamp/ Measure lamp**

Ready lamp: Indicates the MT8862A startup state.  
Connect lamp: Indicates the connection state between MT8862A and DUT.  
Measure lamp: Indicates the MT8862A measurement state.

**11 Input Signal Level lamp**

Indicates the input signal level.

**12 RF Output On/Off lamp**

Indicates setting state of RF output.

**13 Main In/Out 1, 2 connector/Aux Out connector/ Output lamp/Input lamp**

Main In/Out 1, 2 connector: Inputs or outputs RF signal.  
Aux Out connector: Outputs RF signal.  
Output lamp: Indicates the connector's setting state.  
Input lamp: Indicates the connector's setting state.

# Wireless Connectivity Test Set MT8862A Panel Layout

## Rear Panel

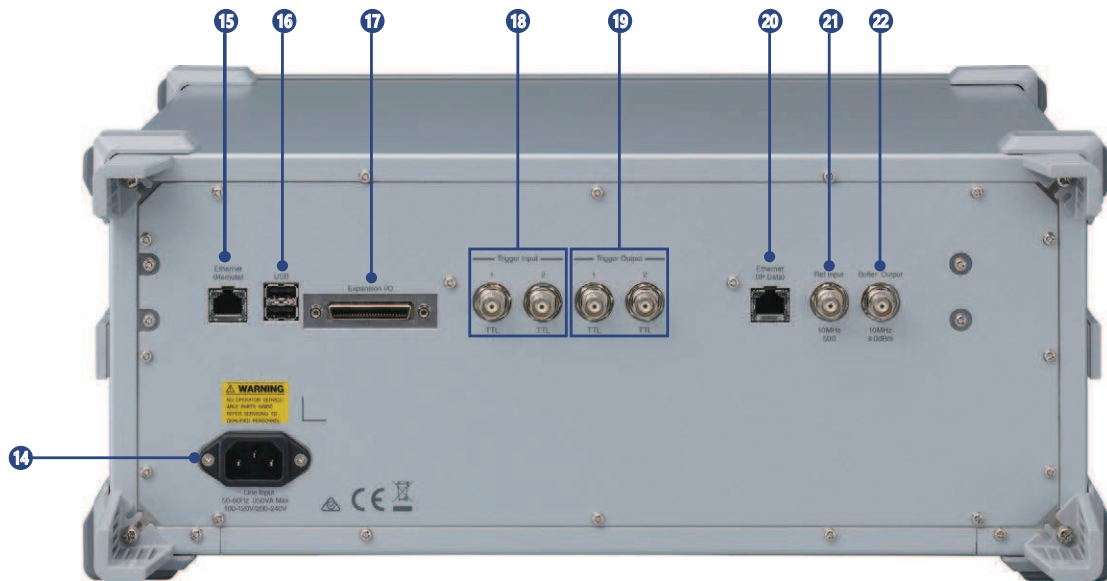

**14 AC inlet**

AC power inlet for the power cable.

**15 Ethernet (Remote) connector**

Connect a personal computer (PC) or Ethernet network for remote control.

**16 USB connector (A type)**

Connector for feature expansion.  
Currently not supported.

**17 Expansion I/O connector**

Connector for synchronization of MT8862A Master/Slave for MIMO Measurement.

**18 Trigger Input**

Inputs external trigger signals (TTL).  
(BNC connector)

**19 Trigger Output**

Outputs trigger signals (TTL).  
(BNC connector)

**20 Ethernet (IP Data) connector**

Connects a PC or Ethernet network for IP Data input/output.

**21 Reference Input connector**

Inputs an external reference frequency signal (10 MHz). (BNC connector)

**22 Buffer Output connector**

Outputs the reference frequency signal (10 MHz).  
(BNC connector)

# Wireless Connectivity Test Set MT8862A Specifications

Receiver	<p>Frequency            Range: 2.4 GHz to 2.5 GHz, 5.0 GHz to 6.0 GHz (with MT8862A-001 installed)            Setting Resolution: 1 Hz            Accuracy: Depends on reference oscillator accuracy</p> <p>Level            Setting Range: -65 to +25 dBm            Setting Resolution: 0.1 dB            Accuracy</p> <p>Measurement Conditions: CW, Measurement Bandwidth: 300 kHz, 20°C to 30°C, Input signal lower than setting level and excluded influence of linearity error, after calibration</p> <p>2.4 GHz ≤ Frequency ≤ 2.5 GHz            ±0.7 dB (-30 dBm ≤ Setting Level ≤ +25 dBm)            ±0.9 dB (-55 dBm ≤ Setting Level &lt; -30 dBm)            ±1.1 dB (-65 dBm ≤ Setting Level &lt; -55 dBm)</p> <p>5.0 GHz ≤ Frequency ≤ 6.0 GHz            ±0.7 dB (-30 dBm ≤ Setting Level ≤ +25 dBm)            ±0.9 dB (-55 dBm ≤ Setting Level &lt; -30 dBm)            ±1.1 dB (-65 dBm ≤ Setting Level &lt; -55 dBm)</p> <p>Measurement Conditions: CW, Measurement Bandwidth: 160 MHz, 20°C to 30°C, Input signal lower than setting level and excluded influence of linearity error, after calibration</p> <p>2.4 GHz ≤ Frequency ≤ 2.5 GHz            ±0.7 dB (-30 dBm ≤ Setting Level ≤ +25 dBm)            ±1.0 dB (-50 dBm ≤ Setting Level &lt; -30 dBm)</p> <p>5.0 GHz ≤ Frequency ≤ 6.0 GHz            ±0.7 dB (-30 dBm ≤ Setting Level ≤ +25 dBm)            ±1.0 dB (-50 dBm ≤ Setting Level &lt; -30 dBm)</p> <p>Linearity            Measurement Conditions: CW, Measurement Bandwidth: 300 kHz, 0 to -40 dB of setting level            ±0.2 dB (-55 dBm ≤ Input Level)            ±0.4 dB (-65 dBm ≤ Input Level &lt; -55 dBm)</p> <p>Measurement Conditions: CW, Measurement Bandwidth: 160 MHz, 0 to -40 dB of setting level            ±0.4 dB (-40 dBm ≤ Input Level)</p>
Transmitter	<p>Frequency            Output Frequency Range: 2.4 GHz to 2.5 GHz, 5.0 GHz to 6.0 GHz (with MT8862A-001 installed)            Setting Resolution: 1 Hz            Accuracy: Depends on reference oscillator accuracy</p> <p>Level            Setting Range: -120 to 0 dBm            Setting Resolution: 0.1 dB            Accuracy</p> <p>Output Setting: CW            20°C to 30°C, Output Level: ≥-110 dBm, after Calibration            ±1.0 dB, ±0.7 dB (typ.) (2.4 GHz ≤ Frequency ≤ 2.5 GHz)            ±1.3 dB, ±1.0 dB (typ.) (5.0 GHz ≤ Frequency ≤ 6.0 GHz)</p> <p>Signal Purity            Harmonic: ≤-25 dBc</p>
Reference Oscillator	<p>At Start: <math>\pm 5 \times 10^{-7}</math> (2 minutes after power-on, at 25°C referenced to frequency at 24 hour after power-on)  <math>\pm 5 \times 10^{-8}</math> (5 minutes after power-on, at 25°C referenced to frequency at 24 hour after power-on)</p> <p>Aging Rate: <math>\pm 1 \times 10^{-7}</math>/year</p> <p>Temperature Characteristics: <math>\pm 2 \times 10^{-8}</math> (5°C to 45°C)</p> <p>Shipped Frequency Accuracy: <math>\pm 2.2 \times 10^{-8}</math> (1 hour after power-on at 20°C to 30°C)</p>

## Wireless Connectivity Test Set MT8862A Specifications

Front Panel Connectors	<p>RF Input/Output Main1, 2 Connector: N-J, 50Ω (nominal) VSWR: <math>\leq 1.5</math> (2.4 GHz <math>\leq</math> Frequency <math>\leq</math> 2.5 GHz) <math>\leq 1.7</math> (5.0 GHz <math>\leq</math> Frequency <math>\leq</math> 6.0 GHz)</p> <p>Aux Out Connector: N-J, 50Ω (nominal) VSWR: <math>\leq 1.5</math> (2.4 GHz <math>\leq</math> Frequency <math>\leq</math> 2.5 GHz) <math>\leq 1.6</math> (5.0 GHz <math>\leq</math> Frequency <math>\leq</math> 6.0 GHz)</p>
Back Panel Connectors	<p>Reference Signal External Reference Input Connector: BNC-J Frequency: 10 MHz, Impedance: 50Ω Operation range: <math>\pm 1</math> ppm, Input Level: <math>-15</math> dBm <math>\leq</math> Level <math>\leq +20</math> dBm, 50Ω (AC coupled)</p> <p>Reference Signal Output Connector: BNC-J Frequency: 10 MHz, Impedance: 50Ω Output Level: <math>\geq 0</math> dBm (AC coupled))</p> <p>External Trigger Trigger Input 1/2 Connector: BNC 1/2, Input Level: TTL</p> <p>Trigger Output 1/2 Connector: BNC 1/2, Output Level: TTL</p> <p>External Interfaces Ethernet (Remote): Required for remote control from external controller Connector: RJ-45, Speed: 1000BASE-T</p> <p>USB: General Purpose, USB 2.0 Connector: USB-A, 2 Ports</p> <p>Expansion I/O: Connector for function expansion Connector: 50 pin (DX10A-50S)</p> <p>Ethernet (IP Data): IP Data Transfer Connector: RJ-45, Speed: 1000BASE-T</p>
Dimensions and Mass	426 (W) $\times$ 177 (H) $\times$ 390 (D) mm (excluding projections), $\leq 14$ kg
Power Supply	<p>Rated voltage: 100 V(ac) to 120 V(ac) or 200 V(ac) to 240 V(ac)</p> <p>Rated frequency: 50 Hz/60 Hz</p> <p>Power consumption: <math>\leq 350</math> VA</p>
Operating Conditions	<p>Temperature Operating: <math>+5^{\circ}\text{C}</math> to <math>+45^{\circ}\text{C}</math>, Storage: <math>-20^{\circ}\text{C}</math> to <math>+60^{\circ}\text{C}</math></p>
CE	<p>EMC: EN61326-1, EN61000-3-2</p> <p>LVD: EN61010-1</p> <p>RoHS: EN50581</p>

# WLAN Measurement Software MX886200A Specifications

Frequency Range	2.4 GHz Band: 2412 MHz to 2484 MHz 5 GHz Band: 5180 MHz to 5825 MHz
Amplitude Measurement	Input Level Range: -50 to +25 dBm Input Level Accuracy: After calibration at 20°C to 30°C ±0.7 dB (-30 dBm ≤ Input Level ≤ +25 dBm) ±1.0 dB (-50 dBm ≤ Input Level < -30 dBm) Linearity: ±0.4 dB (-40 dBm ≤ Input Level, 0 to -30 dB range compared to setting level) Bandwidth: 40 MHz/20 MHz (802.11n), 20 MHz (802.11a/b/g), 80/40/20 MHz (802.11ac, with MX886200A-001 installed)
Spectrum Measurement	Input Level Range: -10 to +25 dBm
EVM (Modulation Accuracy)	EVM Measurement Range: -20 to +25 dBm Residual EVM DSSS: <-28 dB (-20 dBm ≤ Input Level, Average of 20 Packets) OFDM (802.11a/g/n): <-40 dB (-20 dBm ≤ Input Level, Average of 20 Packets, Channel Estimate: Full Packets) OFDM (802.11ac, with MX886200A-001 installed): <-38 dB (-10 dBm ≤ Input Level, Average of 20 Packets, Channel Estimate: Full Packets) OFDM (802.11ax, MX886200A-002 installed): <-42 dB (nom.) (-10 dBm ≤ Input level, Average of 20 Packets, Channel Estimate: Full packet) EVM Data Format: % or dB Measurement Resolution: 0.01% or 0.01 dB
Carrier Frequency Measurement	Measurement Level Range: -20 to +25 dBm Carrier Frequency Accuracy 802.11b: ± (Setting Frequency × Reference Oscillator Accuracy + 1 kHz) (Average of 20 Packets) 802.11a/g/n/ac: ± (Setting Frequency × Reference Oscillator Accuracy + 1 kHz) (Average of 20 Packets, Channel Estimate: Full Packets) 802.11ax: ± (Setting Frequency × Reference Oscillator Accuracy + 5 Hz) (nom.) (more than 100 symbol and 242 tones, and Channel Estimate: Full Packets, Frequency error range: Full packet)
RF Signal Generator	EVM: Packet Length 1472 byte 802.11b: ≤-38 dB rms (2412 MHz to 2484 MHz, Long Preamble, Gaussian Filter BT0.5, 5°C to 45°C) 802.11g (OFDM): ≤-40 dB rms (2412 MHz to 2484 MHz, 20°C to 30°C) 802.11a: ≤-38 dB rms (5180 MHz to 5825 MHz, 20°C to 30°C) 802.11n: ≤-40 dB rms (2412 MHz to 2484 MHz, Long GI, HT-mixed format, Channel Bandwidth 40 MHz, 20°C to 30°C) ≤-38 dB rms (5180 MHz to 5825 MHz, Long GI, HT-mixed format, Channel Bandwidth 40 MHz, 20°C to 30°C) 802.11ac (with MX886200A-001 installed): ≤-37 dB rms (5180 MHz to 5825 MHz, Long GI, Channel Bandwidth 80 MHz, 20°C to 30°C) 802.11ax (MX886200A-002 installed): -40 dB rms (nom.) (5210 MHz, 0.8 μs GI, Channel Bandwidth 80 MHz, 20°C to 30°C)
Functions	Network Functions Connection: Network Connection using Messages defined by IEEE802.11 Role: Access Point (AP/STA) Frame Capture: 1, 2, 4, 8, 16, 32, 64, 128, 256 MB Tx Test Measurement Type: Data, ACK Rx Test Measurement Type: Packet Error Rate (PER), Frame Reception Rate (FRR) Payload Type: All 0's, 0101, 1010, PN7, PN9, Random, Counting MIMO signal transmission (with MX886200A-010) – MIMO signals available for receiver testing. Spatial stream N <sub>SS</sub> : 1 to 2 Space-time-stream N <sub>STS</sub> : 1 to 2 RF chain N <sub>TX</sub> : 2 STBC: Supported only with N <sub>SS</sub> =1 and N <sub>STS</sub> =2 Spatial mapping: Direct mapping Beamforming: Not supported Security encryption (with MX886200A-020 installed) WEP, WPA-Personal, WPA2-Personal

Typical (typ.): Performance not warranted. Most products meet typical performance.  
Nominal (nom.): Values not warranted. Included to facilitate application of product.



## Wireless Connectivity Test Set MT8862A Ordering Information

Please specify the model/order number, name and quantity when ordering.

The names listed in the chart below are Order Names. The actual name of the item may differ from the Order Name.

Model/Order No.	Name
MT8862A	<b>Main Frame</b> Wireless Connectivity Test Set
J0017F	<b>Standard Accessories</b> Power Code: 1 DVD (Operation Manual): 1
W3901AE	MT8862A Operation Manual (Operation) [DVD]
W3902AE	MT8862A Operation Manual (Remote Control) [DVD]
W3903AE	MX886200A WLAN Measurement Software Manual (Operation) [DVD]
W3904AE	MX886200A WLAN Measurement Software Manual (Remote Control) [DVD]
MT8862A-001	<b>RF Options</b> RF Frequency 2.4 GHz, 5 GHz
MX886200A	<b>Software Options</b> WLAN Measurement Software (Requires MT8862A-001)
MX886200A-001	WLAN 802.11ac Option
MX886200A-002	WLAN 802.11ax Option
MX886200A-010	2×2MIMO Measurement Software
MX886200A-020	WLAN Security Function
MT8862A-ES210	<b>Options</b> 2 Years Extended Warranty Service
MT8862A-ES310	3 Years Extended Warranty Service
MT8862A-ES510	5 Years Extended Warranty Service
J0127A	<b>Application Parts</b> Coaxial Cord, 1 m (BNC-P, RG-58A/U, BNC-P)
J0127B	Coaxial Cord, 2 m (BNC-P, RG-58A/U, BNC-P)
J0127C	Coaxial Cord, 0.5 m (BNC-P, RG-58A/U, BNC-P)
J0576B	Coaxial Cord, 1 m (N-P, 5D-2W, N-P)
J0576D	Coaxial Cord, 2 m (N-P, 5D-2W, N-P)
J0322A	Coaxial Cord, 0.5 m (SMA-P, SMA-P)
J0322B	Coaxial Cord, 1.0 m (SMA-P, SMA-P)
J0322C	Coaxial Cord, 1.5 m (SMA-P, SMA-P)
J0322D	Coaxial Cord, 2.0 m (SMA-P, SMA-P)
J0004	Coaxial Adapter (N-P, SMA-J)
J1261A	Ethernet Cable (Straight, 1 m)
J1261B	Ethernet Cable (Straight, 3 m)
J1261C	Ethernet Cable (Cross, 1 m)
J1261D	Ethernet Cable (Cross, 3 m)
J1777A	Expansion IO Cable
B0635A	Rack Mount Kit (EIA)
B0657A	Rack Mount Kit (JIS)
B0636C*	Carrying Case (Hard type, with a front cover and casters)
B0671A	Front Cover (1MW4U)

\*: The Carrying Case B0636C includes a Front Panel Protective Cover (B0671A).

- **United States**

- **Anritsu Americas Sales Company**

450 Century Parkway, Suite 190, Allen,  
TX 75013 U.S.A.  
Phone: +1-800-Anritsu (1-800-267-4878)

- **Canada**

- **Anritsu Electronics Ltd.**

700 Silver Seven Road, Suite 120, Kanata,  
Ontario K2V 1C3, Canada  
Phone: +1-613-591-2003  
Fax: +1-613-591-1006

- **Brazil**

- **Anritsu Eletronica Ltda.**

Praça Amadeu Amaral, 27 - 1 Andar  
01327-010 - Bela Vista - Sao Paulo - SP, Brazil  
Phone: +55-11-3283-2511  
Fax: +55-11-3288-6940

- **Mexico**

- **Anritsu Company, S.A. de C.V.**

Bldv Miguel de Cervantes Saavedra #169 Piso 1, Col. Granada  
Mexico, Ciudad de Mexico, 11520, MEXICO  
Phone: +52-55-4169-7104

- **United Kingdom**

- **Anritsu EMEA Ltd.**

200 Capability Green, Luton, Bedfordshire, LU1 3LU, U.K.  
Phone: +44-1582-433200  
Fax: +44-1582-731303

- **France**

- **Anritsu S.A.**

12 avenue du Québec, Bâtiment Iris 1- Silic 612,  
91140 VILLEBON SUR YVETTE, France  
Phone: +33-1-60-92-15-50  
Fax: +33-1-64-46-10-65

- **Germany**

- **Anritsu GmbH**

Nemetschek Haus, Konrad-Zuse-Platz 1  
81829 München, Germany  
Phone: +49-89-442308-0  
Fax: +49-89-442308-55

- **Italy**

- **Anritsu S.r.l.**

Via Elio Vittorini 129, 00144 Roma, Italy  
Phone: +39-6-509-9711  
Fax: +39-6-502-2425

- **Sweden**

- **Anritsu AB**

Isafjordsgatan 32C, 164 40 KISTA, Sweden  
Phone: +46-8-534-707-00

- **Finland**

- **Anritsu AB**

Teknobulevardi 3-5, FI-01530 VANTAA, Finland  
Phone: +358-20-741-8100  
Fax: +358-20-741-8111

- **Denmark**

- **Anritsu A/S**

c/o Regus Fairway, Arne Jacobsens Allé 7, 5th floor,  
2300 Copenhagen S, Denmark  
Phone: +45-7211-2200

- **Russia**

- **Anritsu EMEA Ltd.**

- **Representation Office in Russia**

Tverskaya str. 16/2, bld. 1, 7th floor.  
Moscow, 125009, Russia  
Phone: +7-495-363-1694  
Fax: +7-495-935-8962

- **Spain**

- **Anritsu EMEA Ltd.**

- **Representation Office in Spain**

Paseo de la Castellana, 141. Planta 5, Edificio Cuzco IV  
28046, Madrid, Spain  
Phone: +34-91-572-6761

- **United Arab Emirates**

- **Anritsu EMEA Ltd.**

- **Dubai Liaison Office**

902, Aurora Tower,  
P O Box: 500311- Dubai Internet City  
Dubai, United Arab Emirates  
Phone: +971-4-3758479  
Fax: +971-4-4249036

- **India**

- **Anritsu India Private Limited**

6th Floor, Indiqube ETA, No.38/4, Adjacent to EMC2,  
Doddanekundi, Outer Ring Road, Bengaluru - 560048, India  
Phone: +91-80-6728-1300  
Fax: +91-80-6728-1301

- **Singapore**

- **Anritsu Pte. Ltd.**

11 Chang Charn Road, #04-01, Shriro House  
Singapore 159640  
Phone: +65-6282-2400  
Fax: +65-6282-2533

- **P.R. China (Shanghai)**

- **Anritsu (China) Co., Ltd.**

Room 2701-2705, Tower A,  
New Caohejing International Business Center  
No. 391 Gui Ping Road Shanghai, 200233, P.R. China  
Phone: +86-21-6237-0898  
Fax: +86-21-6237-0899

- **P.R. China (Hong Kong)**

- **Anritsu Company Ltd.**

Unit 1006-7, 10/F., Greenfield Tower, Concordia Plaza,  
No. 1 Science Museum Road, Tsim Sha Tsui East,  
Kowloon, Hong Kong, P.R. China  
Phone: +852-2301-4980  
Fax: +852-2301-3545

- **Japan**

- **Anritsu Corporation**

8-5, Tamura-cho, Atsugi-shi, Kanagawa, 243-0016 Japan  
Phone: +81-46-296-6509  
Fax: +81-46-225-8352

- **Korea**

- **Anritsu Corporation, Ltd.**

5FL, 235 Pangyoyeok-ro, Bundang-gu, Seongnam-si,  
Gyeonggi-do, 13494 Korea  
Phone: +82-31-696-7750  
Fax: +82-31-696-7751

- **Australia**

- **Anritsu Pty. Ltd.**

Unit 20, 21-35 Ricketts Road,  
Mount Waverley, Victoria 3149, Australia  
Phone: +61-3-9558-8177  
Fax: +61-3-9558-8255

- **Taiwan**

- **Anritsu Company Inc.**

7F, No. 316, Sec. 1, NeiHu Rd., Taipei 114, Taiwan  
Phone: +886-2-8751-1816  
Fax: +886-2-8751-1817