

MT8801B
Radio Communication Analyzer

MX880115A
GSM Measurement Software
Operation Manual

Second Edition

Read this manual before using the equipment.
Keep this manual with the equipment.

Measuring Instruments Division
Measurement Group
ANRITSU CORPORATION

Document No.: M-W1328AE-2.0

Safety Symbols

To prevent the risk of personal injury or loss related to equipment malfunction, Anritsu Corporation uses the following safety symbols to indicate safety-related information. Insure that you clearly understand the meanings of the symbols BEFORE using the equipment.

(Some or all of the following symbols may not be used on all Anritsu equipment. In addition, there may be other labels attached to products which are not shown in the diagrams in this manual.)

Symbols used in manual

DANGER  This indicates a very dangerous procedure that could result in serious injury or death if not performed properly.

WARNING  This indicates a hazardous procedure that could result in serious injury or death if not performed properly.

CAUTION  This indicates a hazardous procedure or danger that could result in light-to-severe injury, or loss related to equipment malfunction, if proper precautions are not taken.

Safety Symbols Used on Equipment and in Manual

The following safety symbols are used inside or on the equipment near operation locations to provide information about safety items and operation precautions. Insure that you clearly understand the meanings of the symbols and take the necessary precautions BEFORE using the equipment.



This indicates a prohibited operation. The prohibited operation is indicated symbolically in or near the barred circle.



This indicates an obligatory safety precaution. The obligatory operation is indicated symbolically in or near the circle.



This indicates warning or caution. The contents are indicated symbolically in or near the triangle.



This indicates a note. The contents are described in the box.



These indicate that the marked part should be recycled.

MT8801B Radio Communication Analyzer
MX880115A GSM Measurement Software
Operation Manual

18 July 1997 (First Edition)

19 September 1997 (Second Edition)

- The contents of this manual may be changed without prior notice.
- No part of this manual may be reproduced without the prior written permission of Anritsu Corporation.

Copyright © 1997, ANRITSU CORPORATION.

Printed in Japan

For Safety

WARNING



1. ALWAYS refer to the operation manual when working near locations at which the alert mark shown on the left is attached. If the operation, etc., is performed without heeding the advice in the operation manual, there is a risk of personal injury. In addition, the equipment performance may be reduced.

Moreover, this alert mark is sometimes used with other marks and descriptions indicating other dangers.



2. When supplying power to this equipment, connect the accessory 3-pin power cord to a 3-pin grounded power outlet. If a grounded 3-pin outlet is not available, before supplying power to the equipment, use a conversion adapter and ground the green wire, or connect the frame ground on the rear panel of the equipment to ground. If power is supplied without grounding the equipment, there is a risk of receiving a severe or fatal electric shock.

Repair

WARNING 

3. This equipment cannot be repaired by the user. DO NOT attempt to open the cabinet or to disassemble internal parts. Only Anritsu-trained service personnel or staff from your sales representative with a knowledge of electrical fire and shock hazards should service this equipment. There are high-voltage parts in this equipment presenting a risk of severe injury or fatal electric shock to untrained personnel. In addition, there is a risk of damage to precision parts.

Falling Over

4. This equipment should be used in the correct position. If the cabinet is turned on its side, etc., it will be unstable and may be damaged if it falls over as a result of receiving a slight mechanical shock.

For Safety

WARNING

Battery fluid

5. DO NOT short the battery terminals and never attempt to disassemble it or dispose of it in a fire. If the battery is damaged by any of these actions, the battery fluid may leak.

This fluid is poisonous.

DO NOT touch it, ingest it, or get in your eyes. If it is accidentally ingested, spit it out immediately, rinse your mouth with water and seek medical help. If it enters your eyes accidentally, do not rub your eyes, irrigate them with clean running water and seek medical help. If the liquid gets on your skin or clothes, wash it off carefully and thoroughly.

LCD

6. This instrument uses a Liquid Crystal Display (LCD); DO NOT subject the instrument to excessive force or drop it. If the LCD is subjected to strong mechanical shock, it may break and liquid may leak.

This liquid is very caustic and poisonous.

DO NOT touch it, ingest it, or get in your eyes. If it is ingested accidentally, spit it out immediately, rinse your mouth with water and seek medical help. If it enters your eyes accidentally, do not rub your eyes, irrigate them with clean running water and seek medical help. If the liquid gets on your skin or clothes, wash it off carefully and thoroughly.

For Safety

CAUTION

Changing Fuse

CAUTION 

1. Before changing the fuses, ALWAYS remove the power cord from the poweroutlet and replace the blown fuses. ALWAYS use new fuses of the type and rating specified on the fuse marking on the rear panel of the cabinet.

T□□□A indicates a time-lag fuse.

□□□A or F□□□A indicates a ordinary melt type fuse.

There is risk of receiving a fatal electric shock if the fuses are replaced with the power cord connected.

Cleaning

2. Keep the power supply and cooling fan free of dust.
 - Clean the power inlet regularly. If dust accumulates around the power pins, there is a risk of fire.
 - Keep the cooling fan clean so that the ventilation holes are not obstructed. If the ventilation is obstructed, the cabinet may over-heat and catch fire.
3. Use two or more people to lift and move this equipment, or use a trolley. There is a risk of back injury, if this equipment is lifted by one person.

Heavy weight



Check Terminal



4. Never input a signal of more than the specified voltage between the measured terminal and ground. Input of an excessive signal may damage the equipment.
5. Do not take out the floppy disk if LED lamp of the floppy disk drive is on. If it is taken out, the contents of the storage medium will be damaged, resulting in floppy disk drive failure.

For Safety

CAUTION

Memory Back-up Battery

6. The power for memory back-up of the MT8801B is supplied by a poly-carbomonofluoride lithium battery. this battery should only be replaced by a battery of the same type; since replacement can only be made by Anritsu, contact the nearest Anritsu representative when replacement is required.

At the end of it's life, the battery should be recycled or disposed properly.

Note: The Battery life is about 7 years. Early battery replacement is recommended.

Storage Medium

7. The MT8801B stores data and programs using a floppy disk (FD), memory card (MC), and backed-up memories.

Data and programs may be lost due to improper use or failure.

Anritsu therefore recommends that you back up the memory.

ANRITSU CANNOT COMPENSATE FOR ANY MEMORY LOSS.

Please pay careful attention to the following points. Do not remove the floppy disk from the equipment being accessed.

(FD)

- Do not touch the FD directly or by using any object.
- Do not place the equipment where dirty and dusty.
- Isolate the FD and memory card from static electricity.
- Avoid to placing the FD in direct sunlight or near heating sources.
- Store under temperature of 40° to 54°C, humidity of 8 to 90% (No condensation).

(Memory card)

- Isolate the memory card from static electricity.

(Backed-up memory)

- Isolate the memory from ststic electricity.

Disposing of The Product

8. The MT8801B uses chemical compound semiconductor including arsenic.

At the end of its life, the MT8801B should be recycled or disposed properly according to the local disposal regulations.

Equipment Certificate

Anritsu Corporation certifies that this equipment was tested before shipment using calibrated measuring instruments with direct traceability to public testing organizations recognized by national research laboratories including the Electrotechnical Laboratory, the National Research Laboratory and the Communication Research laboratory, and was found to meet the published specifications.

Anritsu Warranty

Anritsu Corporation will repair this equipment free-of-charge if a malfunction occurs within 1 year after shipment due to a manufacturing fault.

When this software alone is purchased, Anritsu will repair or exchange this software free-of-charge at the company's own discretion if it provides defective within 1 year after purchase when used as described in the operation manual.

This warranty is rendered void under any or all of the following conditions.

- The fault is outside the scope of the warranty conditions described in the operation manual.
- The fault is due to misoperation, misuse, or unauthorized modification or repair of the equipment by the customer.
- The fault is due to severe usage clearly exceeding normal usage.
- The fault is due to improper or insufficient maintenance by the customer.
- The fault is due to natural disaster including fire, flooding and earthquake, etc.
- The fault is due to use of non-specified peripheral equipment, peripheral parts, consumables, etc.
- The fault is due to use of a non-specified power supply or in a non-specified installation location.

In addition, this warranty is valid only for the original equipment purchaser. It is not transferable if the equipment is resold.

Anritsu Corporation will not accept liability for equipment faults due to unforeseen and unusual circumstances, nor for faults due to mishandling by the customer.

Anritsu Corporation Contact

If this equipment develops a fault, contact Anritsu Corporation or its representatives at the address in this manual.

Software License Agreement

Please read this Software License Agreement before using the accompanying software program (hereafter this software).

You are authorized to use this software only if you agree to all the terms of this License.

By opening the sealed package containing this software, you are agreeing to be bound by the terms of this License.

If you do not agree to these terms, return the unopened software package to Anritsu Corporation (hereafter Anritsu).

1. License

- (1) This License gives you the right to use this software on one MT8801B Radio Communication Analyzer (hereafter computer system).
- (2) To use this software on one computer system, this License allows you to make one copy of this software on the storage device of your computer system.
- (3) You must obtain a site license to use this software on more than one computer system even if such computer systems are not operating simultaneously.

2. Copyright

- (1) Although you are licensed to use this software, Anritsu retains the copyright.
- (2) Although you have purchased this software, rights other than those specified in this License are not transferred to you.
- (3) You may not print, copy, modify, create derivative works, incorporate in other software programs, decompile or disassemble this software in whole or in part, without obtaining prior written permission from Anritsu.

3. Copying

Notwithstanding item (3) of section 2 above, you may make one copy of this software for backup purposes only. In this case, you may only use either the backup copy or the original copy of this software.

4. Termination

- (1) Anritsu will deem this License to be automatically terminated if you fail to comply with any provision of this License. Upon termination, you will lose all rights to this software.
- (2) Either party (Anritsu or yourself) to this Software License Agreement may terminate this Agreement by giving 1 months notice in writing to the other party.
- (3) Upon termination of this License for any reason, you must either immediately destroy this software and related documentation, or return it to Anritsu.

Front Panel Power Switch

To prevent malfunction caused by accidental touching, the front power switch of this equipment turns on the power if it is pressed continuously for about one second in the standby state. If the switch is pressed continuously for one second in the power-on state, the equipment enters the standby state.

In the power-on state, if the power plug is removed from the outlet, then reinserted into it, the power will not be turned on. Also, if the lines is disconnected due to momentary power supply interruption or power failure, the power will not be turned on (enters the standby state) even if the line is recovered.

This is because this equipment enters the standby state and prevents incorrect data from being acquired when the line has to be disconnected and reconnected.

For example, if the data acquisition requires a long time at the BER measurement, momentary power supply interruption (power failure) might occur during measurement and the line could be recovered automatically to power-on. In such a case, the equipment may mistake incorrect data for correct data without recognizing the momentary power supply interruption.

If this equipment enters the standby state due to momentary power supply interruption or power failure, check the state of the measuring system and press the front power switch to restore power to this equipment.

Further, if this equipment is built into a system and the system power has to be disconnected then reconnected, the power for this equipment must also be restored by pressing the front power switch.

Consequently, if this equipment is built into remote monitoring systems that use MODEMs, the standby function of this equipment must be modified.

Trade Mark

[IBM] is a registered trademark of the IBM Corporation.

[HP] is a registered trademark of the Hewlett-Packard Company.

[MS-DOS] is a registered trademark of the Microsoft Corporation.

[NEC] is a registered trademark of the NEC Corporation.

CE Marking

Anritsu affix the CE Conformity Marking on the following product (s) accordance with the Council Directive 93/68/EEC to indicate that they conform with the EMC directive of the European Union (EU).

CE Conformity Marking



1. Product Name/Model Name

Product Name: Radio Communication Analyzer
Model Name: MT8801B

2. Applied Directive

EMC : Council Directive 89/336/EEC
Safety: Council Directive 73/23/EEC

3. Applied Standards

EMC:

Electromagnetic radiation:

EN55011(ISM, Group 1, Class A equipment)

Immunity:

EN50082-1

	Performance Criteria*
IEC801-2 (ESD) 4 kVCD, 8 kVAD	B
IEC801-3 (Rad.) 3 V/m	A
IEC801-4 (EFT) 1 kV	B

*: Performance Criteria

A: No performance degradation or function loss

B: Self-recovered temporary degradation of performance or temporary loss of function

Safety: EN61010-1 (Installation Category II, Pollution Degree 2)

3

3

3

ABOUT THIS MANUAL

- (1) This manual describes the operation of the MT8801B Radio Communication Analyzer using the measurement software installed.
- (2) MX880115A Operation Manual
The MT8801B Radio Communication Analyzer and MX880115A GSM Measurement Software operation manuals consist of the following two manuals. Use the manuals matching the usage objective.

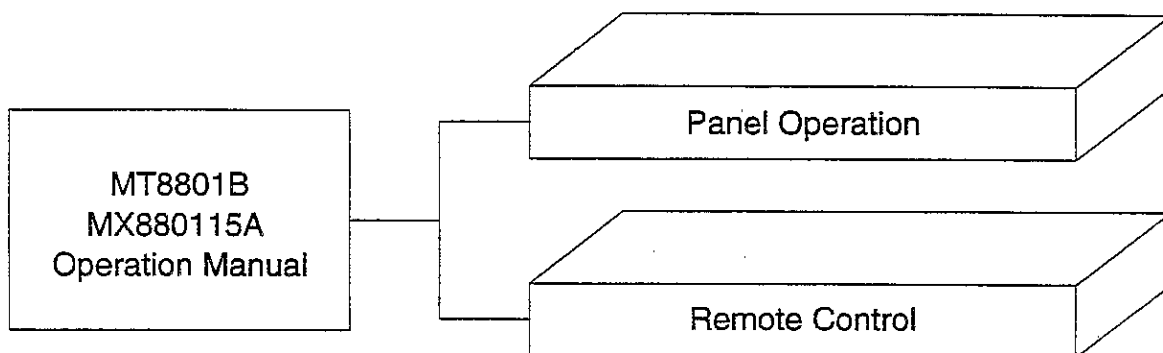

Panel operation: Outlines the MT8801B and describes its preparations, panel explanations, operations, performance text, calibrations, storage and transportation.

Remote Control: Describes RS-232C/GPIB remote control and the sample programs etc. .

MT8801B
Radio Communication Analyzer

MX880115A
GSM Measurement Software
Operation Manual
(Panel Operation)

TABLE OF CONTENTS

For Safety	iii
ABOUT THIS MANUAL	I
SECTION 1 GENERAL	1-1
1.1 General	1-3
1.2 Manual Composition	1-4
1.3 Equipment Configuration	1-5
1.3.1 Standard configuration	1-5
1.3.2 Option	1-5
1.3.3 Software	1-6
1.4 Optional Accessories and Peripherals	1-7
1.5 Specifications	1-8
SECTION 2 PREPARATIONS BEFORE USE	2-1
2.1 Installation Site and Environmental Conditions	2-3
2.2 Safety Measures	2-4
2.2.1 Safety measures for power supply	2-4
2.2.2 Maximum power to connector	2-5
2.3 Preparations before Power-on	2-5
2.3.1 Protective grounding	2-6
2.3.2 Replacing fuse	2-7
2.4 Installation	2-8
2.4.1 Rack mounting	2-8
2.4.2 Stacking	2-8
2.5 Precautions for Handling Storage Media	2-9
2.5.1 Floppy disk	2-9
SECTION 3 PANEL LAYOUT AND OVERVIEW OF OPERATION	3-1
3.1 Panel Layout	3-3
3.1.1 Front panel layout	3-3
3.1.2 Rear panel layout	3-6
3.1.3 Panel layout	3-7
3.2 Overview of Operation	3-8
3.2.1 Overview of functions	3-8
3.2.2 Overview of operation	3-9
(1) Main menu selection	3-9
(2) Selection of measurement items	3-9
(3) Item input	3-9

(4) Outline of screen configuration	3-10
SECTION 4 OPERATION.....	4-1
4.1 Turning on and off the Power	4-3
4.1.1 Turning on the Power.....	4-4
4.1.2 Turning off the Power.....	4-6
(1) Normal power-off procedures	4-6
(2) Power-off procedures for storage or long stop	4-6
4.1.3 Setup state after power-on	4-6
4.2 Screen Descriptions	4-7
(1) Screen layout	4-7
(2) Function keys	4-10
(3) Entering the data	4-12
4.3 GSM Transmitter and Receiver Test --- TX and RX Tester Mode	4-14
4.3.1 Preparations	4-14
(1) Setup	4-14
(2) Calibration before measurement.....	4-15
(a) Power meter function	4-15
(b) Burst-power measurement function	4-15
(3) Correcting RF cable loss when conducting the transmitter test (TX Measure mode): Setting User Cal Factor	4-16
(4) Correcting RF cable loss when conducting the receiver test (RX Measure mode): Setting Offset Value	4-16
4.3.2 Selecting and changing the measurement system: Change System screen	4-17
(1) Changing the built-in measuring system	4-17
(2) Loading measuring systems from an external floppy disk.....	4-17
4.3.3 Setting the measurement system conditions: Instrument Setup screen	4-18
4.3.4 Setting the screen display color: Change Color menu	4-23
4.3.5 Setting the common measurement parameters: Setup Common Parameter screen.....	4-25
4.3.6 Transmitter test: TX Measure mode	4-33
(1) Setting the parameters: Setup TX Measure Parameter screen	4-33
(a) Setting the parameters: Setup TX Measure Parameter screen	4-34
(b) Setting items for all item measurement of the transmitter: Select All Measure Item screen	4-36
(2) Transmitter all item measurement: All Measure screen	4-41
(3) Modulation analysis: Modulation Analysis screen (value display) Constellation screen, Eye Diagram screen, Phase Error screen, Magnitude Error screen (waveform display: 4 screens)	4-45
(a) Modulation analysis (value display): Modulation Analysis screen	4-45
(b) Modulation analysis (waveform display): Constellation screen, Eye Diagram screen, Phase Error screen, Magnitude Error screen	4-48

(4) RF power (burst magnitude) measurement: RF Power screen, Setup Template screen	4-53
(a) Measuring the power: RF Power screen	4-53
(b) Setting the template: Setup Template screen	4-60
(5) Output RF spectrum measurement: Output RF Spectrum screen	4-62
(6) RF power (average) measurement: Power Meter screen	4-66
4.3.7 Receiver test: RX Measure mode	4-69
(1) Setting parameters: Setup RX Measure Parameter screen	4-69
(2) Measuring the bit error rate: Bit Error Rate screen	4-72
4.3.8 Connection test: Call Processing mode	4-76
4.3.9 Saving and recalling parameter data:	
Save Parameter screen, Recall Parameter screen	4-81
4.3.10 Operating the file: File Operation screen	4-87
4.3.11 Screen hard copy...Copy	4-90
4.3.12 Settings relating to remote control and panel key control	4-91

SECTION 5 PERFORMANCE TEST 5-1

5.1 Requirement for Performance Tests	5-3
5.2 Instruments Required for Performance Test	5-4
5.3 Performance Tests	5-5
5.3.1 Reference oscillator frequency stability	5-5
(1) Specifications	5-5
(2) Test instruments	5-5
(3) Setup	5-5
(4) Procedure	5-6
5.3.2 Frequency/modulation measurement accuracy	5-7
(1) Specifications	5-7
(2) Test instruments	5-7
(3) Setup	5-7
(4) Test procedure: frequency/modulation accuracy	5-8
5.3.3 Transmission power measurement accuracy	5-9
(1) Specification	5-9
(2) Test instrument	5-9
(3) Setup	5-9
(4) Test procedure: transmission power measurement accuracy	5-10
5.3.4 Signal-generator frequency accuracy	5-11
(1) Specifications	5-11
(2) Test instrument	5-11
(3) Notes on test	5-11
(4) Setup	5-11
(5) Procedure	5-11

5.3.5	Signal-generator output level accuracy	5-12
(1)	Specifications	5-12
(2)	Test instruments	5-12
(3)	Notes on test	5-12
(4)	Setup	5-12
(5)	Procedure	5-13
5.3.6	Signal-generator modulation accuracy	5-14
(1)	Specification	5-14
(2)	Test instrument	5-14
(3)	Setup	5-14
(4)	Procedure	5-14
5.3.7	Example of performance test result entry sheet	5-15
SECTION 6 CALIBRATION		6-1
6.1	Calibration Requirements	6-3
6.2	Equipment Required for Calibration	6-3
6.3	Calibration 6-4	
6.3.1	Calibrating the reference crystal oscillator	6-4
(1)	Specifications	6-4
(2)	Instruments required for calibration	6-4
(3)	Setup	6-4
(4)	Calibration procedure	6-5
SECTION 7 STORAGE AND TRANSPORTATION		7-1
7.1	Cleaning the Cabinet	7-3
7.2	Storage Precautions	7-3
7.2.1	Precautions before storage	7-3
7.2.2	Recommended storage conditions	7-3
7.3	Repacking and Transportation	7-4
7.3.1	Repacking	7-4
7.3.2	Transportation	7-4
APPENDIXES		Appendix-I

SECTION 1 GENERAL

TABLE OF CONTENTS

1.1	General	1-3
1.2	Manual Composition	1-4
1.3	Equipment Configuration	1-5
1.3.1	Standard configuration	1-5
1.3.2	Option	1-5
1.3.3	Software	1-6
1.4	Optional Accessories and Peripherals	1-7
1.5	Specifications	1-8

1.1 General

The MT8801B Radio Communication Analyzer is a measuring-instrument platform that consists of the hardware components necessary for testing digital mobile telecommunication terminals. Using the MT8801B along with the available measurement software allows you to evaluate the performance of mobile telecommunication equipment with efficiency.

By using measurement software MX880115A, you can use the MT8801B as an integrated measuring instrument (hereafter called this analyzer) that can evaluate the functions and performance of the mobile telecommunication equipment conforming to GSM (Global System for Mobile Telecommunication: European standard for digital portable telephones).

This analyzer is provided with measurement functions such as mobile-station (MS) control, transmission measurement, error rate (reception) measurement, and sequence monitor. Only this analyzer is adequate to test the GSM mobile stations for transmission and reception.

Measurement functions offered by this analyzer are as follows:

- Mobile station control: A mobile station can be placed in a GSM-specified measurement state by performing call processing. Normally, the transmission and reception are measured with a mobile station set in this state.
- Transmission measurement: GSM-specified RF-modulated signals (e.g., carrier frequency, signal level, and modulation accuracy) can be measured.
- Reception measurement: A BER (Bit Error Rate) can be measured by demodulating the RF-modulated signal from a mobile station, allowing the receiving sensitivity of the mobile station to be measured based on the measured BER.
- Sequence monitoring: A performance test can be conducted for origination, termination, disconnection, hand-over, and voice echo-back.

This analyzer is equipped with a high-speed digital signal processing technology, allowing you to carry out transmission and reception measurements quickly and with high accuracy.

1.2 Manual Composition

This manual is made up of the following sections.

Section 1 General

Describes the introduction, composition, function specifications and performance of this instrument.

Section 2 Preparations before Use

Explains various work to be performed before using this instrument.

Section 3 Panel Layout and Overview of Operation

Explains the basic items for operating this equipment.

Section 4 Operation

Explains basic operation and how to operate for each measurement item.

Section 5 Performance Test

Explains the performance test method for this instrument.

Section 6 Calibration

Describes calibration items and methods for the periodical calibration of this equipment.

Section 7 Storage and Transportation

Describes how to store and transport this equipment.

Appendix A Screens and Function Key Transition Diagrams

1.3 Equipment Configuration

This paragraph describes the configuration of the MX880115A standard accessories.

1.3.1 Standard configuration

The table below shows the configuration of the MX880115A with the standard accessories.

Table 1-1 MX880115A Standard Accessories

Item	Order No.	Name	Qty	Remarks
Software	MX880115A	GSM Measurement Software	1	
Accessories	W1328AE	Operation manual	1	For GSM system

The table below shows the configuration of the MT8801B with the standard accessories.

Table 1-2 MT8801B Standard Accessories

Item	Order No.	Name	Qty	Remarks
Main instrument	MT8801B	Radio communication analyzer	1	
Accessories	J0576B	Coaxial cord	1	N-P-5D-2W-N-P, 1m
	J0768	Coaxial adapter	2	N-J-TNC-P
	J0017F	Power cord	1	2.6m
	J0266	Adapter	1	3 poles to 2 poles plug conversion adapter
	F0014	Fuse	2	6.3A for 100V/200V system

1.3.2 Option

The table below shows the MT8801B options.

These are sold separately.

Table 1-3 Options

Option No.	Name
01	Analog measurement
02	SG local
07	Spectrum analyzer

1.3.3 Software

The table below shows the MT8801B softwares.

Table 1-4 Softwares

Model/Order No.	Name	Remarks
MX880113A	IS-136A Measurement Software	Sequence Monitor provided. Options 01 and 02 are required.
MX880115A	GSM Measurement Software	Sequence Monitor provided. Option 02 is required.
MX880116A	PDC Measurement Software with Call Processing.	Sequence Monitor provided. Option 02 is required.
MX880117A	PHS Measurement Software with Call Processing.	Sequence Monitor provided. Option 02 is required.
MX880131A	PDC Measurement Software	
MX880132A	PHS Measurement Software	

1.4 Optional Accessories and Peripherals

The following table shows the optional accessories and peripherals for the MT8801B which are all sold separately.

Table 1-5 Optional Accessories and Peripherals

<Optional accessories>

Model*/Order No.	Name*	Remarks
J0127C	Coaxial cord	BNC-P•RG-58A/U•BNC-P, 0.5m
J0769	Coaxial adapter	BNC-J•TNC-P
J0040	Coaxial adapter	N-P•BNC-J
J0007	GPIB connection cable	408JE-101, 1m
J0008	GPIB connection cable	408JE-102, 2m
J0742A	RS-232C cable	1m, D-sub 25pins, for PC-9800 Series personal computer of NEC Corp.
J0743A	RS-232C cable	1m, D-sub 9pins, for IBM PC/AT personal computer
MN1607A	Coaxial switch	DC to 3GHz, 50Ω, externally controllable
MA1612A	4-Port junction pad	5 to 3000MHz
J0395	Attenuator for high power	30dB, 30W, DC to 9GHz
B0329D	Protective cover	
B0331D	Front handle kit	2 pcs/set
B0332	Coupling plate	4 pcs/set
B0333D	Rack mounting kit	
B0334D	Carrying case	With casters and protective cover

* Please specify the model/order number, name, and quantity when ordering.

<Peripherals and applicable units>

Model*/Order No.*	Name*
MS8604A	Digital mobile radio transmitter tester
MD1620B	Signaling tester (PDC)
MD1620C	Signaling tester (PHS)
MD6420A	Data transmission analyzer
MS2602A	Spectrum analyzer
MG3670B	Digital modulation signal generator

* Please specify the model/order number, name, and quantity when ordering.

1.5 Specifications

The MT8801B specifications are listed in Tables 1-6 to 1-7 below.

Table 1-6 MT8801B Specifications

General	Frequency range		300 kHz to 3 GHz
	Maximum input level		+40 dBm(10 W) (MAIN connector) +20 dBm (100 mW) (auxiliary input connector)
	Input/output connector	MAIN I/O connector	N-type connector Impedance 50 Ω , VSWR \leq 1.2 (Frequency \leq 2.2 GHz) VSWR \leq 1.3 (Frequency $>$ 2.2 GHz)
		Auxiliary input connector, Auxiliary output connector	TNC connector
	Reference oscillator	Frequency	10 MHz
		Starting characteristic	$\leq 5 \times 10^{-8}$ /day After 10 minutes of warm-up, referred to frequency after 24 hours of warm-up
		Aging rate	$\leq 2 \times 10^{-8}$ /day $\leq 1 \times 10^{-7}$ /year Referred to frequency after 24 hours of warm-up,
		Temperature characteristic	5×10^{-8} (0 to 50°C) Referred to frequency at 25°C,
	External standard input		10 MHz or 13 MHz(within ± 1 ppm), Input level : 2 to 5 Vp-p
	Power meter	Frequency range	
Level range		0 to +40 dBm	
Measurement accuracy		$\pm 10\%$ after zero point calibration	
Signal generator	Frequency	Frequency range	300 kHz to 3 GHz
		Resolution	1 Hz
		Accuracy	Accuracy of reference frequency ± 100 mHz
	Output level	Level range	-143 to -28 dBm (MAIN connector) -143 to -3d Bm (Auxiliary output connector)
		Level accuracy	10 MHz to 1 GHz : ± 1.5 dB (≥ -123 dBm), ± 3 dB (≥ -133 dBm) > 1 GHz : ± 2 dB (≥ -123 dBm), ± 4 dB (≥ -133 dBm)
	Signal purity	Spurious	≤ -50 dBc (at CW), offset frequency: 100 kHz to 50 MHz Where Carrier frequency: Other than 1300 MHz to 1400 MHz, and 2000 MHz to 2100 MHz ≤ 40 dBc for all band
Harmonics		≤ -25 dBc (at CW)	
Others	Display		Color TFT LCD display Size: 7.8 inches Number of dots: 640 x 480
	Hard copy		Enables data hard copy on the display through a parallel interface. (applicable only for EPSON VP-series or equivalent)
	External control	GPIOB	Function: This equipment is specified as a device, can be controlled from external controller. (excluding power switch and FD ejection key) No controller function Interface function: SH1, AH1, T6, L4, SR1, RL1, PP0, DC1, DT1, C0, and E2
		Parallel	Function: Conforms to the Centronics. Outputs printing data to a printer. Data line exclusive for output: 8 Control line: 4 (BUSY, DTSB, ERROR, PE) Connectors: D-sub 25 pins, Female (Equivalent to the connector of IBM-PC/AT built-in printer)
		RS-232C	Controlled from an external controller (except for the power switch) Baud rate: 1200, 2400, 4800, or 9600 bps
Dimensions Mass	Dimensions	221.5 mm (H) X 426 mm (W) X 451 mm (D)	
	Mass	≤ 22 kg	
Power supply	Power supply	85 to 132 V, 170 to 250 V 47.5 to 63 Hz, ≤ 300 VA Automatic voltage switch system	
	Operating temperature range	0 to 50°C	

Table 1-7 MX880115A: GSM Measurement Software Specifications

Transmission measurement	Modulation/frequency measurement	Frequency range	10 MHz to 2.2 GHz	
		Input level range	-5 to +40 dBm (Average power within burst) : MAIN connector -30 to +15 dBm (Average power within burst) : AUX Input connector	
		Carrier frequency	Accuracy: \pm (accuracy of the reference frequency +10 Hz)	
		Residual phase error	Accuracy: \leq 0.5 degrees rms, \leq 2 degrees peak	
		Waveform display	Eye Pattern display, Phase Error vs Bit No. display, Magnitude Error vs Bit No. display, IQ Diagram display	
	Amplitude measurement	Frequency range	10 MHz to 2.2 GHz	
		Input level range	+10 to +40 dBm (Average power within burst): MAIN connector	
		Transmission power	Accuracy: \pm 10% (MAIN connector) (after calibration by using built-in power meter)	
		Carrier-off power	Normal mode	Measurement range: \geq 55 dB (compared with burst average power)
			Wide dynamic range mode	Measurement range: \geq 80 dB (compared with 1 W of burst average power) Measurement limit is decided by average noise level \leq -50 dBm, 100 MHz to 2.1 GHz).
	Rise/fall characteristic	Displays rising/falling edges while synchronizing to modulation data of signal to be measured. Standard line display possible. Raising/falling time measurement (measured by 100 MHz bandwidth)		
	Output RF spectrum measurement	Frequency range	100 MHz to 2.2 GHz	
		Input level range	+10 to +40 dBm (Average power within burst): MAIN connector	
		Modulation portion measurement range	\geq 50 dB (\geq 200 kHz offset) \geq 66 dB (\geq 250 kHz offset)	
		Transient portion measurement range	\geq 57 dB (\geq 400 kHz offset)	
		Measurement point	\pm 100 kHz, \pm 200 kHz, \pm 250 kHz, \pm 400 kHz, \pm 600 kHz, \pm 800 kHz, \pm 1000 kHz, \pm 1200 kHz, \pm 1400 kHz, \pm 1600 kHz, \pm 1800 kHz, \pm 2000 kHz	
	All measurement items	Frequency range	Same as each the measurement item.	
		Input level range	Same as each the measurement item.	
		Measurement item	Transmission frequency Transmission frequency error Phase error(rms,peak) Transmission power Carrier off power Carrier on/off ratio Pass/Fail judgement for response time specification of transmission output Burst position Transmission power vs time Reception level report from mobile station (only at DUT Control : Call Proc) Reception quality report from mobile station (only at DUT Control : Call Proc) Transmission power report from mobile station (only at DUT Control : Call Proc) Timing advance report from mobile station (only at DUT Control : Call Proc) Output spectrum	
		Measurement time	When DUT Control = None \leq 2.0 s (When amplitude measurement at normal mode) \leq 2.5 s (When amplitude measurement at wide dynamic range mode) When DUT Control = Call Proc \leq 3.0 s (When amplitude measurement at normal mode) \leq 3.5 s (When amplitude measurement at wide dynamic range mode) (The time from the start to completion (SRQ signal generation) of measurement by GPIB control)	

Table 1-7 MX880115A: GSM Measurement Software Specifications

(Cont.)

Reception measurement	Signal generator	Frequency range	10 MHz to 3 GHz
		Level range	-143 to -28 dBm (MAIN connector) -143 to -3 dBm (Auxiliary Output connector)
		Modulation system	GMSK, BbT=0.3 (Gaussian filter)
		Phase error	≤2 degrees rms
		Burst repeat period	4.515ms Note that one burst is outputted in one frame.
		Modulation data	Continuous waveform output: • PN9 and PN15 pseudo-random patterns and arbitrary 4-bit data repetitive patterns Burst waveform output: • Communication-channel 10 test patterns selectable
	Error rate measurement	Function	FER/Cib/CII error rate measurement is done by receiving RF modulated signal for error rate measurement conformed to GSM specification.
		Measurement pattern	10 test patterns selectable
		Number of measurement samples	FER : 1 to 99 999 999 Cib : 1 to 99 999 999 CII : 1 to 99 999 999
	Call Processing	Pass/Fail judgement of registration/origination/termination/communication/hand-over/disc from network/disc from mobile station	

SECTION 2 PREPARATIONS BEFORE USE

TABLE OF CONTENTS

- 2.1 Installation Site and Environmental Conditions 2-3
- 2.2 Safety Measures 2-4
 - 2.2.1 Safety measures for power supply 2-4
 - 2.2.2 Maximum power to connector 2-5
- 2.3 Preparations before Power-on 2-5
 - 2.3.1 Protective grounding 2-6
 - 2.3.2 Replacing fuse 2-7
- 2.4 Installation 2-8
 - 2.4.1 Rack mounting 2-8
 - 2.4.2 Stacking 2-8
- 2.5 Precautions for Handling Storage Media 2-9
 - 2.5.1 Floppy disk 2-9

SECTION 2 PREPARATIONS BEFORE USE

2.1 Installation Site and Environmental Conditions

The MT8801B Radio Communication Analyzer operates normally at temperatures from 0° to 50°C. However, for the best performance, the following locations should be avoided.

- Where there is severe vibration
- Where the humidity is high
- Where the equipment will be exposed to direct sunlight
- Where the equipment will be exposed to active gases

To insure long-term trouble-free operation, the equipment should be used at room temperature and in a location where the power supply voltage does not fluctuate greatly.

CAUTION

- Prevention of failure due to condensation

If the MT8801B is used at normal temperatures after it has been used or stored for a long time at low temperature, there is a risk of short-circuiting caused by condensation.

To prevent this risk, do not turn the power on until the MT8801B has been allowed to dry out sufficiently.

Fan clearance:

To suppress any internal temperature increase, the MT8801B has a fan on the rear panel as shown in the diagram below. Leave a gap of at least 10 cm between the rear panel and the wall, nearby equipment or obstructions so that fan ventilation is not blocked.

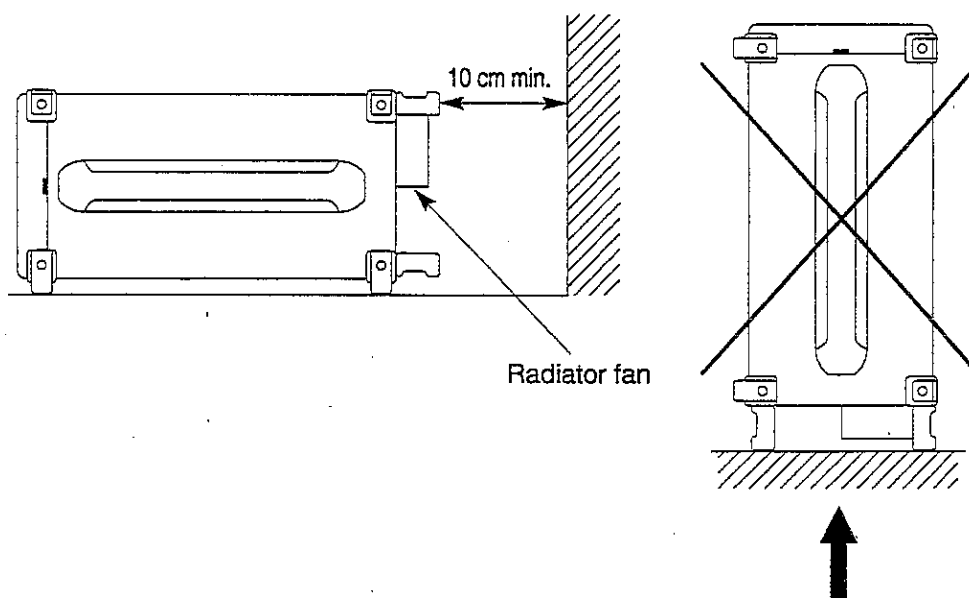

Do not use the equipment on its side.

2.2 Safety Measures

This paragraph explains the safety procedures which should be followed under all circumstances to counter the risk of an accidental electric shock, damage to the equipment or a major operation interruption.

2.2.1 Safety measures for power supply

WARNING

-
- Before power-on:
- Protective grounding
The MT8801B must be connected to ground. If the power is turned on without taking this countermeasure, there is a risk of receiving an accidental electric shock.
 - Power supply voltage
In addition, it is essential to check the power supply voltage. If an abnormal voltage that exceeds the specified value is input, there is an accidental risk of damage to the MT8801B and fire.
- During power on:
- To maintain the MT8801B, sometimes it is necessary to make internal checks and adjustments with the top, bottom or side covers removed while power is supplied. Very-high, dangerous voltages are used in the MT8801B; if insufficient care is taken, there is a risk of an accidental electric shock being received or of damage to the equipment. To maintain the MT8801B, request service by service personnel who has received the required training.
-

In the following, special notes on safety procedures are explained for sections other than Section 2. To prevent accidents, read this section together with the related sections before beginning operation.

2.2.2 Maximum power to connector

The allowable maximum power to the MT8801B connectors are as follows.

Connector	Allowable maximum power
Main Input/Output	10 W (40 dBm)
AUX Input	100 mW (20 dBm)
AUX Output	Exclusive output connector, 0.5 mW (-3 dBm)
AF Input	30 Vrms
AF Output	Dedicated output connector, 5 Vrms (output impedance : 600 Ω), 0.5 Vrms (output impedance : 50 Ω)
DUT Interface	TTL level
Reference Input	2 to 5 Vp-p
10MHz Buffered Output	Dedicated output connector, TTL level
Detector Output	Dedicated output connector, TTL level
BER Input connectors	TTL level
Ext Trig Input	TTL level
Ext Trig Output	Dedicated output connector, TTL level
Ext FM Input	± 10 Vp-p
Demod Output	Dedicated output connector, ± 8 Vp-p

CAUTION

- Excessive power protection
Never apply power more than the allowable maximum power. Also, do not input external signal to the output connector.

2.3 Preparations before Power-on

The MT8801B operates normally when connected to 85 to 135 Vac, 47.5 to 63 Hz, or 170 to 250 Vac, 47.5 to 63 Hz AC power supply via the power inlet.

To prevent the following problems, take the necessary procedures described on the following pages before power is supplied.

- Accidental electric shock
- Damage caused by abnormal voltage
- Ground current problems

To protect the operator, the following WARNING and CAUTION notices are attached to the rear panel of the MT8801B.

WARNING 
NO OPERATOR SERVICE-
ABLE PARTS INSIDE.
REFER SERVICING TO
QUALIFIED PERSONNEL.

WARNING
Disassembly, adjustment, maintenance, or other access inside this instrument by unqualified personnel should be avoided. Maintenance of this instrument should be performed only by Anritsu trained service personnel who are familiar with the risks involved of fire and electric shock.

CAUTION 
FOR CONTINUED FIRE
PROTECTION REPLACE
ONLY WITH SPECIFIED
TYPE AND RATED FUSE.

CAUTION
Replace only with fuses of the specified type and rating. The use of improper fuses may cause fire.

2.3.1 Protective grounding

(1) Grounding with 3-pole power outlet

The power supply polarity of the 3-pole (grounded, 2-pole type) matches that of the 3-core power cord plug. Therefore, the MT8801B is connected to ground potential when the power cord is connected to the plug. As a result, it is not necessary to connect the FG terminal to ground.

(2) Grounding with conversion adapter

If a 3-pole power socket is not provided, use the 3-pole to 2-pole conversion adapter as shown in the figure below. Connect the green wire protruding from the 3 to 2 conversion adapter to ground.

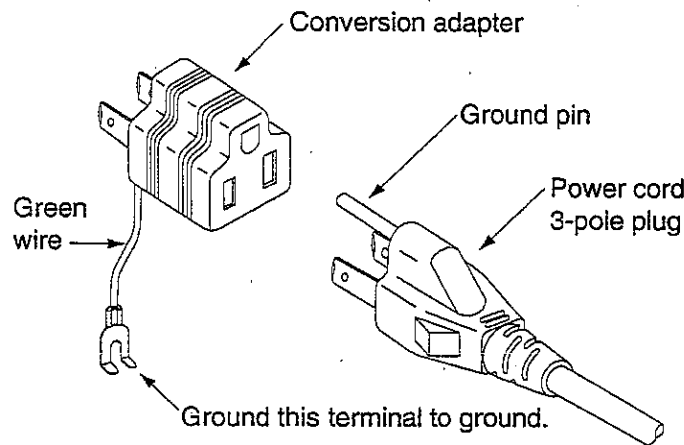

(3) Grounding with frame ground (FG) terminal

If a 3-pole ac power supply outlet is not available and the green wire cannot be grounded, the protective frame ground (FG) terminal on the rear panel must be connected directly to ground potential.

WARNING ⚠

- Prevention of danger using protective ground terminal
- If power is supplied without protective grounding, there is a risk of accidental electric shock. If a 3-pole power supply outlet is not available and the green wire cannot be grounded, the protective frame-ground (FG) terminal on the rear panel must be connected to ground potential before power is supplied to the MT8801B.

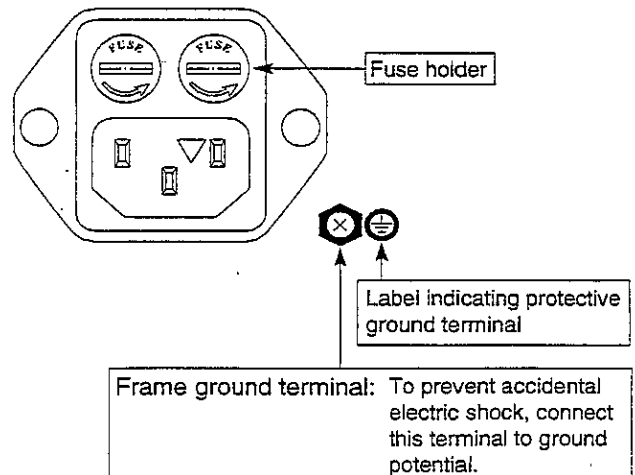

2.3.2 Replacing fuse

The MT8801B with standard accessories has two spare fuses (T6.3A250V). Use these fuses to replace the blown fuses. If the fuses must be replaced, locate and remedy the cause before replacing the blown fuses.

Power supply system	Voltage range	Fuse rating plate	Fuse rating	Fuse name	Model/Order No.
100 Vac	100 – 120V	T6.3A	6.3A, 250V	T6.3A 250V	F0014
200 Vac	200 – 240V	T6.3A			

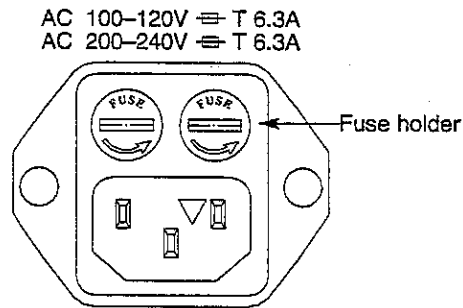

WARNING ⚠

- Prevention of electric shock

Before replacing the fuses, turn the power switch off and remove the power cord from the power outlet. If the fuses are replaced while power is being supplied, there is a serious risk of electric shock.

- Confirmation before turning the power on

After replacing fuses, the protective grounding mentioned above must be provided before turning the power on again, and the proper AC power supply voltage must be confirmed. If the AC power supply voltage is improper, there is a risk of the internal circuits of the MT8801B being damaged.

CAUTION ⚠

- Check on replacing fuses

If the replacement fuses are not provided, obtain replacement fuses of the same rated voltage and current as the fuses in the fuse holders.

If the replacement fuses are not of the same type, they may not fit correctly, and failure will occur due to melting of the fuse.

When the rated voltage and current are over-sufficient, the fuses may not blow even if there is a risk of damage to the equipment by fire.

After performing the safety procedures, replace the fuses according to the following procedure.

Step	Procedure
1	Turn off the power switches on the front and rear panels, then remove the power cord from the power supply outlet.
2	Use a screwdriver to turn the fuse holder cap shown in the figure counterclockwise. The cap and fuse are removed together as a unit from the AC inlet.
3	Remove the fuse from the fuse cap and replace it with a spare fuse.
4	Return the fuse cap with the fuse to the fuse holder, then fasten it by turning it clockwise with the screwdriver.

* Contact the Anritsu service department for fuses by specifying the model name, order number, name, and quantity.

2.4 Installation

2.4.1 Rack mounting

The B0333D Rack Mounting Kit (sold separately, Table 1-3) is required to mount the MT8801B in a rack.

The installation method is included in the rack mount kit diagram.

2.4.2 Stacking

When stacking several MT8801Bs or stacking the MT8801B with equipment of the same width as the MT8801B, the B0332 Coupling Plate (sold separately, Table 1-3) are required.

2.5 Precautions for Handling Storage Media

2.5.1 Floppy disk

The following explains how to handle the floppy disk media of this instrument.

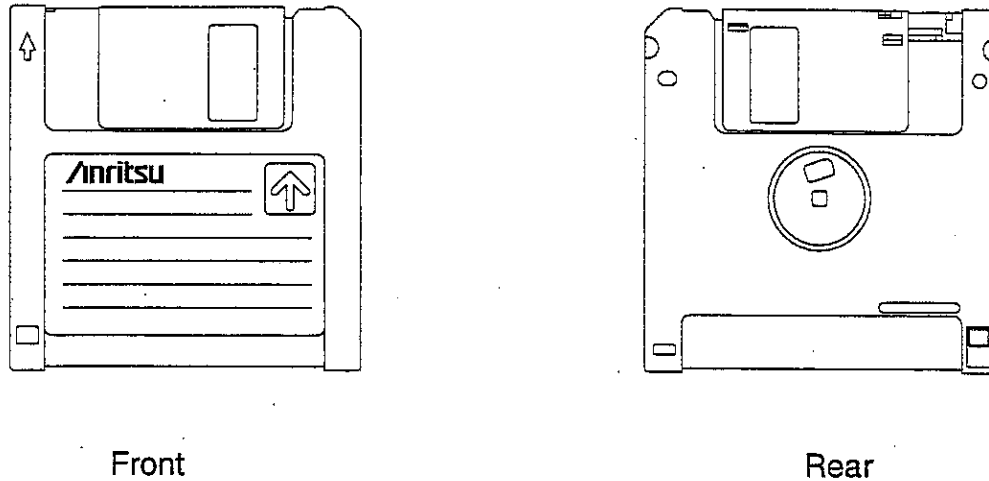

Fig. 2-1 3.5-inch Floppy Disk

(1) Precautions

The plastic case of the 3.5-inch floppy disk has a shutter to protect the disk inside. When the disk is inserted into the disk drive, the shutter opens to expose part of the disk. Do not touch the shutter.

The following care must be taken for handling the disk.

- When a floppy disk is inserted, and LED lamp on the disk drive lights, do not eject the disk. Otherwise, the memory contents may be damaged, resulting in disk drive failure.
- Do not directly touch the magnetic surface with your hand or any object.
- Do not expose the disk to dust.
- Do not place the disk near any magnetic objects.
- Do not place the disk in direct sunlight or near heater.
- Store the disk under a temperature range of 4° to 53°C, and humidity of 8 to 90% (no condensation).

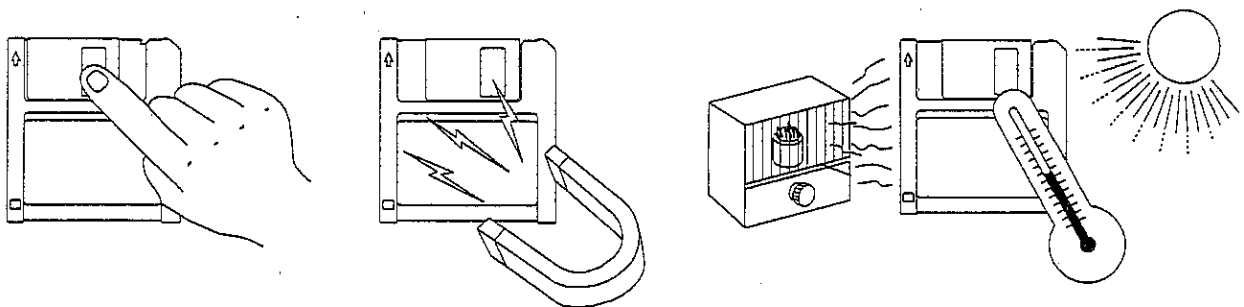

(2) Write-protection tab

A write-protection tab is provided on the 3.5-inch floppy disk.

Sliding this tab downward in the arrow direction beforehand prevents accidental writing and deletion. (A write operation is disabled in this state.)

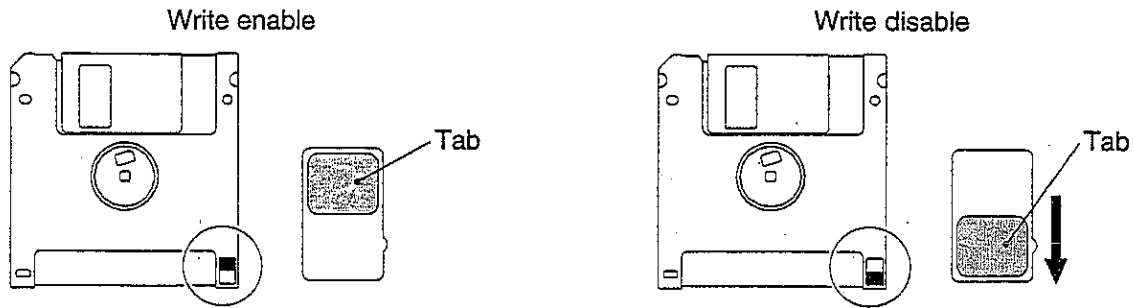

Fig. 2-2 Write-protection Tab for 3.5-inch Floppy Disk

(3) Inserting and ejecting the floppy disk

With the front surface of the floppy disk facing up, fully insert the disk in the arrow direction until a clicking sound is heard.

To eject, press the eject button on the right side of the disk drive. Remove the disk after confirming that the LED lamp is off.

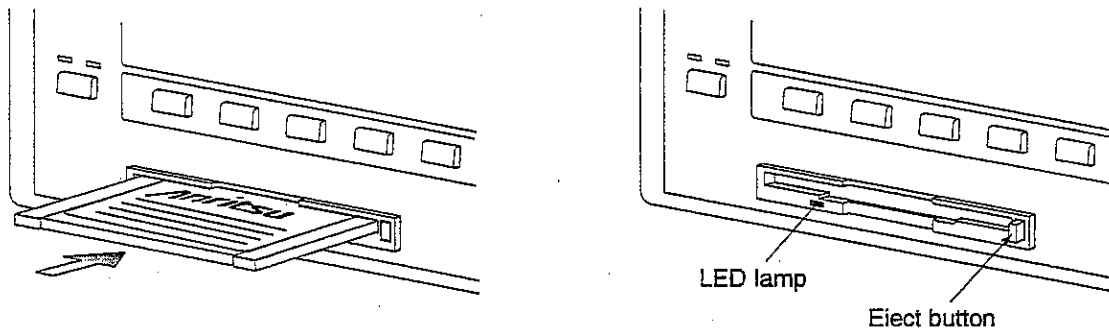

Fig. 2-3 Inserting and Ejecting the 3.5-inch Floppy Disk

SECTION 3

PANEL LAYOUT AND OVERVIEW OF OPERATION

TABLE OF CONTENTS

3.1	Panel Layout	3-3
3.1.1	Front panel layout	3-3
3.1.2	Rear panel layout	3-6
3.1.3	Panel layout	3-7
3.2	Overview of Operation	3-8
3.2.1	Overview of functions	3-8
3.2.2	Overview of operation	3-9
	(1) Main menu selection	3-9
	(2) Selection of measurement items	3-9
	(3) Item input	3-9
	(4) Outline of screen configuration	3-10

3.1 Panel Layout

This paragraph describes the keys, switches, LEDs, and connectors on the front and rear panels of the MT8801B Radio Communication Analyzer.

3.1.1 Front panel layout

This paragraph describes the keys, switches, LED, connectors, and the rotary knob on the front panel.

No.	Display	Function
1	F1,F2,F3,F4,F5,F6	<p>Main function keys</p> <p>Group of keys that select and execute the corresponding menus displayed on the LCD screen.</p> <p>When the [Main Func] F6 key is on, the menus for F1 to F5 are placed in MT8801B measurement mode.</p> <p>When the [Main Func] F6 key is off, the menus of F1 to F5 are displayed for the currently used screen function.</p>
2	F7,F8,F9,F10,F11,F12	<p>Function keys</p> <p>Group of keys that select and execute the corresponding menus displayed on the LCD screen. These screen functions are related to the current operation.</p>
3	Next Menu	
	▲	Displays the next page of the function key menu.
	◀	Displays the next page of the main function key menu.

No.	Display	Function outline
4		Key group for entering data.
	Shift	Switches the function of keys with a shift function. When the shift key is pressed, the key's LED goes on. Subsequent operation must be started with this LED on.
	BS	Back space key used to correct input data.
	0,..-/+ ,1,2,3, A/4,B/5,C/6,D/7,E/8,F/9	Numeric keys (ten-keypad) used for data input. These keys become alphanumeric keys at shift function activation.
	(Definition key group)	The data input using the numeric keys is defined with these keys.
	W/GHz/dBm/dB	Validates data when W/GHz/dBm/dB unit system data is input.
	mW/MHz/dB μ /sec	Validates data when mW/MHz/dB μ /sec unit system data is input.
	μ W/kHz/mV/ms	Validates data when μ W/kHz/mV/ms unit system data is input.
	nW/Hz/ μ V/ μ s/Enter	Validates data when nW/Hz/ μ V/ μ s unit system data or non-unit system data is input.
5	Measure	Key group used to start measurement.
	Single	Key used to execute measurement once.
	Continuous	Key used to execute measurement continuously.
6	Copy	Outputs display screen to the specified printer.(Hard copy function)
7	Cursor	Key group used to control the cursor on the LCD screen.
	Set	Opens the input window for data in the item pointed to by the cursor. After the completion of data entry, the window is closed.
	Cancel	Closes the window. The input data becomes invalid.
	^ < > v	Moves the cursor.
8	Step	Key group increment or decrement numeric data.
	^	Increments numeric data by the specified step value.
	v	Decrements numeric data by the specified step value.
		Entry using these keys is always validated every time the data incremented or decremented.
9	(Rotary knob)	Knob used for data input. When this knob is turned clockwise, the value increases and when it is turned counterclockwise, the value decreases. For input by the rotary knob, data is validated each time it is incremented/decremented. This knob is also used in item selection.

No.	Display	Function outline
10	Main Input/Output	Input/output connector for RF signal.(N type connector)
11	AUX	Auxiliary input/output connectors for RF signal.(TNC connector)
	Input	Auxiliary input connector for RF signal. This is used when the output level of DUT is too low.
	Output	Auxiliary output connector for RF signal. This is used when the sensitivity of DUT is too low.
12	AF Input	AF signal input connector for Option 01(Analog), (BNC connector)
	AF Output	AF signal output connector for Option 01(Analog), (BNC connector)
13	DUT Interface	Multi-pole connector used to control the DUT and measure the BER (D-SUB connector, 25-pin, female).
14	(Floppy disk drive)	Slot in which the floppy disk is loaded for saving and recalling data, and loading system program.
15	Stby On	Change-over switch to turn the standby power supply on when the Line Input on/off switch on the rear of this instrument is turned on. In Standby mode, power is only supplied to the reference crystal oscillator.
16	Panel Lock	Invalidates all key operations except the Panel Lock key and the Stby On power supply switch on the front panel. In lock mode, the LED on this key goes on.
17	Remote Local	Resets GPIB remote mode and returns to local mode. In GPIB remote mode, the LED (Remote) goes on.
18	Preset	Initializes measurement parameters.

3.1.2 Rear panel layout

This paragraph describes the switch and connectors on the rear panel.

No.	Display	Function
19	O I	Input switch for AC power supply. If this switch is turned off, the Power switch on the front panel cannot be turned on.
20	(Fuses)	Power supply fuses. For safety, always use fuses of the specified rating.
21		Frame grounding terminal. For safety, always ground this terminal.
22	(Memory card cover)	The memory card is built-in. Close the cover for card use.
23	(Power supply inlet)	For safety, always use a power supply of the rated voltage.
24	GPIB	GPIB interface connector.
25	Parallel	Parallel interface connector (conforms to Centronics type). Used to connect printer (D-SUB connector, 25-pin, female).
26	Serial	RS232C interface connector (D-SUB connector, 9-pin, female).
27	10MHz Buffered Output	10 MHz reference signal (TTL level) for internal use is output (BNC connector).
28	10MHz/13MHz Reference Input	10 MHz or 13 MHz reference signal (2 to 5 Vp-p) is input (BNC connector).
29	Detector Output	RF burst signal detection output connector (BNC connector).
30	BER Input	Signal input connectors for measuring bit error rate (BNC connector).
	Data	Input connector for measurement data of bit error rate (BNC connector). TTL level signal is input.
	Clock	Input connector for clock of bit error rate (BNC connector). TTL level signal is input.
31	Ext FM Input	External FM modulation signal input connector for Option 01(Analog), (BNC connector)
32	Demod Output	FM demodulated signal output connector for Option 01(Analog), (BNC connector)
33	Ext Trig Input	Input connector for external trigger signal (BNC connector). TTL level signal is input.
34	Ext Trig Output	Output connector for external trigger signal (BNC connector). TTL level signal is output.
35	(Fan)	Instrument internal air cooling fan.

3.1.3 Panel layout

The front panel and rear panel layouts are shown in Figs. 3-1 and 3-2, respectively.

The numbers in the diagram correspond to those in paragraphs 3.1.1 and 3.1.2.

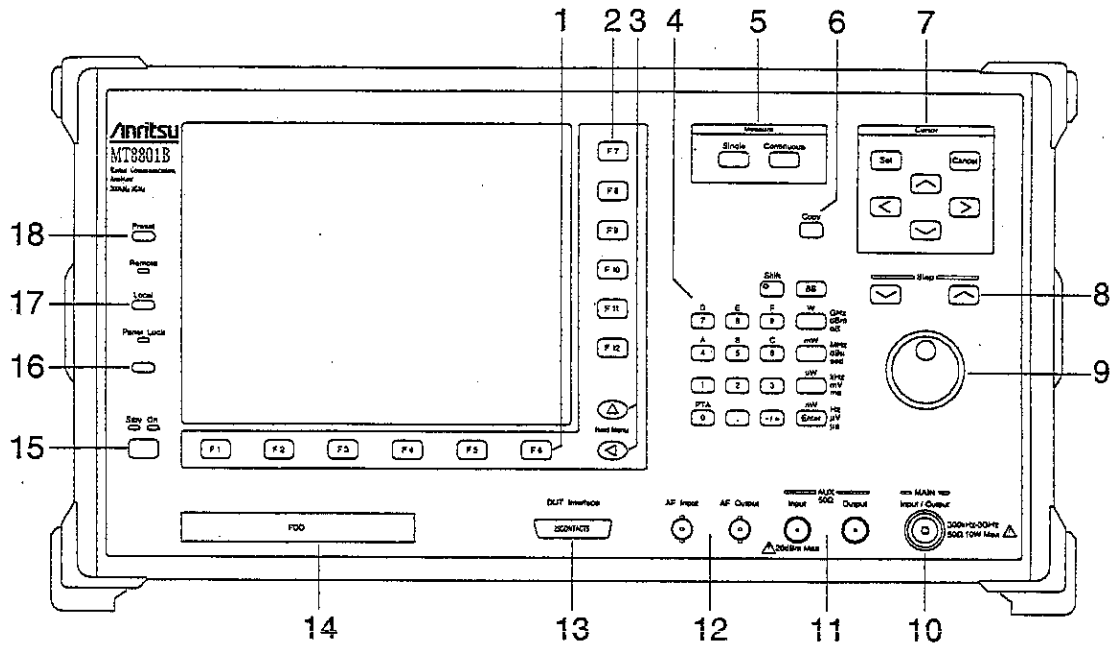

Fig. 3-1 Front Panel

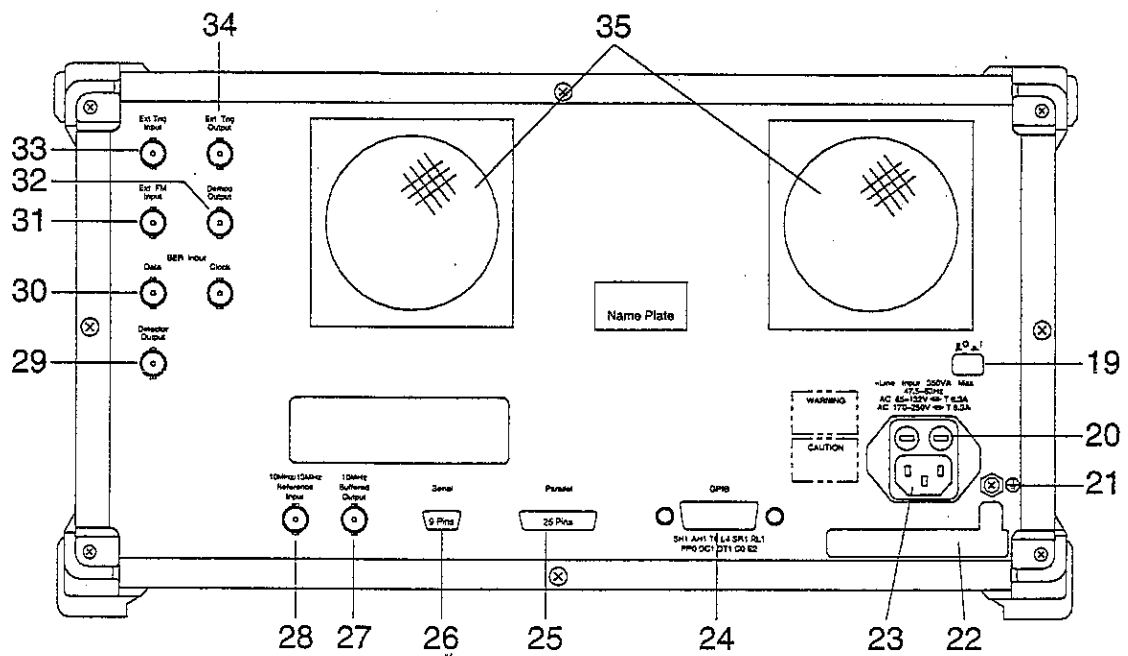

Fig. 3-2 Rear Panel

3.2 Overview of Operation

3.2.1 Overview of functions

With measurement software MX880115A installed, the MT8801B can test a GSM mobile station (MS) for transmission and reception performance.

- GSM transmission/reception measurements: TX & RX Tester mode

Using the function menu displayed on the screen, carry out the following measurements:

1. Mobile station control

The MT8801B originates a call to a mobile station or it receives a call originated by the mobile station, then places the mobile station in the state where transmission and reception measurements can be conducted.

2. Transmission measurement: TX Measure mode

The MT8801B receives an RF signal from the mobile station to make measurements with respect to the following items:

- Modulation analysis:

Carrier frequency, carrier frequency error, phase error: RMS value/maximum value, magnitude error, constellation, I-Q diagram

- RF power (burst magnitude with magnitude standard-line template) measurement

Magnitudes at slot/frame/leading-edge/trailing-edge

- Output RF spectrum

- Power meter

Average power using power sensor

- Automatic all TX selected-item measurement

3. Reception measurement: RX Measure mode

In the measurement state, a mobile station receives an RF signal (for measurement) from the MT8801B and loops this signal back to the MT8801B. The MT8801B receives the loop-backed RF signal to measure the data BER (Bit Error Rate). A receiving sensitivity can be tested by measuring the error rate at the specified reception level of the mobile station.

4. Call processing: Call Processing mode

The MT8801B monitors the call processing sequence (origination, termination, disconnection, hand-over) to judge the pass/fail of the sequence.

In addition to the above functions, the MT8801B also supports the following functions:

- Save/recall

A maximum of 100 measurement conditions (parameters) can be saved on, or recalled from, a 3.5-inch floppy disk.

- Copy

The screen display can be printed out on the external printer via a parallel interface (Centronics).

- GPIB

The MT8801B can be remotely controlled using an external controller via a GPIB interface.

- RS232C

3-8 The MT8801B can be remotely controlled using an external controller via a serial interface (RS232C).

3.2.2 Overview of operation

At power-on operation begins in "TX&RX Tester" (Transmitter and Receiver test) status (Setup Common Parameter screen).

(1) Main menu selection

If measurement is to be started from another mode, or from other than a measurement mode, first select one of the main menu items, as shown below.

TX&RX Tester (Transmitter and Receiver test)

Recall (Parameter file recall)

Save (Parameter file save)

File Operation (File retrieval/deletion/protect, FD initialization)

Change System (Measurement system change)

Instrument Set (MT8801B main-frame setting)

Change Color (Selection of screen color)

First press the [Main Func On/Off] F6 key to ON, then select the desired function by using main function keys F1 to F5 and the Next Menu key [◀].

(2) Selection of measurement items

Items are set by using cursor keys ([↖], [↘], [←], [→]), and other function keys while observing the screen menu.

Press the [Set] key to open the input window.

(3) Item input

For selection items displayed: Select the required value by using the cursor keys or rotary knob.

For numeric values: Input data using the numeric keys, and validate by pressing a unit key, [Enter] key, or [Set] key.

The window closes.

(4) Outline of screen configuration

The screen configuration is shown below. A tree-shaped Hierarchical configuration of items below each the main menu is indicated. (Details of operation are explained in Section 4. The screens, setup items and function key flowchart for each screen are summarized in Appendix A, "Screen and Function Key Transition Diagrams.")

[Overview of screens]

- TX&RX Tester mode
 - Setup Common Parameter screen
(Measurement Condition Set screen common to TX and RX Measure modes)
 - TX Measure mode
 - Setup TX Measure Parameter screen
(TX Measurement Condition Set screen)
 - Select All Measure Item screen
(TX All Measurement-Value-List Item Set screen)
 - All Measure screen
(TX All Measurement-Value-List Measure screen)
 - Modulation Analysis screen
(TX Modulation-Analysis screen --- Numeric display)
 - Constellation screen, Eye Diagram screen, Phase Error screen, Magnitude Error screen
(TX Modulation Analysis screens --- 4 waveform displays)
 - RF Power screen
(TX RF Power (Burst Magnitude) Measure screen)
 - Setup Template screen
(Template Set screen)
 - Output RF Spectrum screen
(RF Output Spectrum Measure screen)
 - Power Meter screen
(TX RF Power (Average) Measure screen)
 - RX Measure mode
 - Setup RX Measure Parameter screen
(RX Measurement Condition Set screen)
 - Bit Error Rate screen
(RX Bit Error Rate (BER) Measure screen)
 - Call Processing mode
 - Setup Call Processing Parameter screen (Call Processing Test Condition Set screen)
 - Sequence Monitor screen (Call Processing Operation Sequence Display screen)

- Recall mode
 - └ Recall Parameter screen
(Screen for recalling parameter-file)
- Save mode
 - └ Save Parameter screen
(Screen for saving parameter-file)
- File Operation mode
 - └ File Operation screen
(Screen for file retrieval/deletion/protection-setup in FD, and FD initialization)
- Change System mode
 - └ Change System screen
(Screen for changing TX&RX Tester mode measurement system)
- Instrument Setup mode
 - └ Instrument Setup screen
(Screen for setting up RS232C/GPIB, etc. for MT8801B main frame)

Note: Change Color mode (Selection for screen display color) is setup using the function key menu. There is no screen in Change Color mode.

SECTION 4 OPERATION

TABLE OF CONTENTS

4.1	Turning on and off the Power	4-3
4.1.1	Turning on the Power	4-4
4.1.2	Turning off the Power	4-6
	(1) Normal power-off procedures	4-6
	(2) Power-off procedures for storage or long stop	4-6
4.1.3	Setup state after power-on	4-6
4.2	Screen Descriptions	4-7
	(1) Screen layout	4-7
	(2) Function keys	4-10
	(3) Entering the data	4-12
4.3	GSM Transmitter and Receiver Test -- TX and RX Tester Mode	4-14
4.3.1	Preparations	4-14
	(1) Setup	4-14
	(2) Calibration before measurement	4-15
	(a) Power meter function	4-15
	(b) Burst-power measurement function	4-15
	(3) Correcting RF cable loss when conducting the transmitter test (TX Measure mode): Setting User Cal Factor	4-16
	(4) Correcting RF cable loss when conducting the receiver test (RX Measure mode): Setting Offset Value	4-16
4.3.2	Selecting and changing the measurement system: Change System screen	4-17
	(1) Changing the built-in measuring system	4-17
	(2) Loading measuring systems from an external floppy disk	4-17
4.3.3	Setting the measurement system conditions: Instrument Setup screen	4-18
4.3.4	Setting the screen display color: Change Color menu	4-23
4.3.5	Setting the common measurement parameters: Setup Common Parameter screen	4-25

4.3.6	Transmitter test: TX Measure mode	4- 33
(1)	Setting the parameters: Setup TX Measure Parameter screen	4-33
(a)	Setting the parameters: Setup TX Measure Parameter screen	4-34
(b)	Setting items for all item measurement of the transmitter: Select All Measure Item screen	4-36
(2)	Transmitter all item measurement: All Measure screen	4-41
(3)	Modulation analysis: Modulation Analysis screen (value display) Constellation screen, Eye Diagram screen, Phase Error screen, Magnitude Error screen (waveform display: 4 screens)	4-45
(a)	Modulation analysis (value display): Modulation Analysis screen	4-45
(b)	Modulation analysis (waveform display): Constellation screen, Eye Diagram screen, Phase Error screen, Magnitude Error screen	4-48
(4)	RF power (burst magnitude) measurement: RF Power screen, Setup Template screen	4-53
(a)	Measuring the power: RF Power screen	4-53
(b)	Setting the template: Setup Template screen	4-60
(5)	Output RF spectrum measurement: Output RF Spectrum screen	4-62
(6)	RF power (average) measurement: Power Meter screen	4-66
4.3.7	Receiver test: RX Measure mode	4- 69
(1)	Setting parameters: Setup RX Measure Parameter screen	4-69
(2)	Measuring the bit error rate: Bit Error Rate screen	4-72
4.3.8	Connection test: Call Processing mode	4-76
4.3.9	Saving and recalling parameter data: Save Parameter screen, Recall Parameter screen	4-81
4.3.10	Operating the file: File Operation screen	4-87
4.3.11	Screen hard copy...Copy	4-90
4.3.12	Settings relating to remote control and panel key control	4-91

4.1 Turning on and off the Power

The MT8801B has two power switches: The Stby/On switch on the front panel and $\uparrow \circ \downarrow$ (main power) switch on the rear panel.

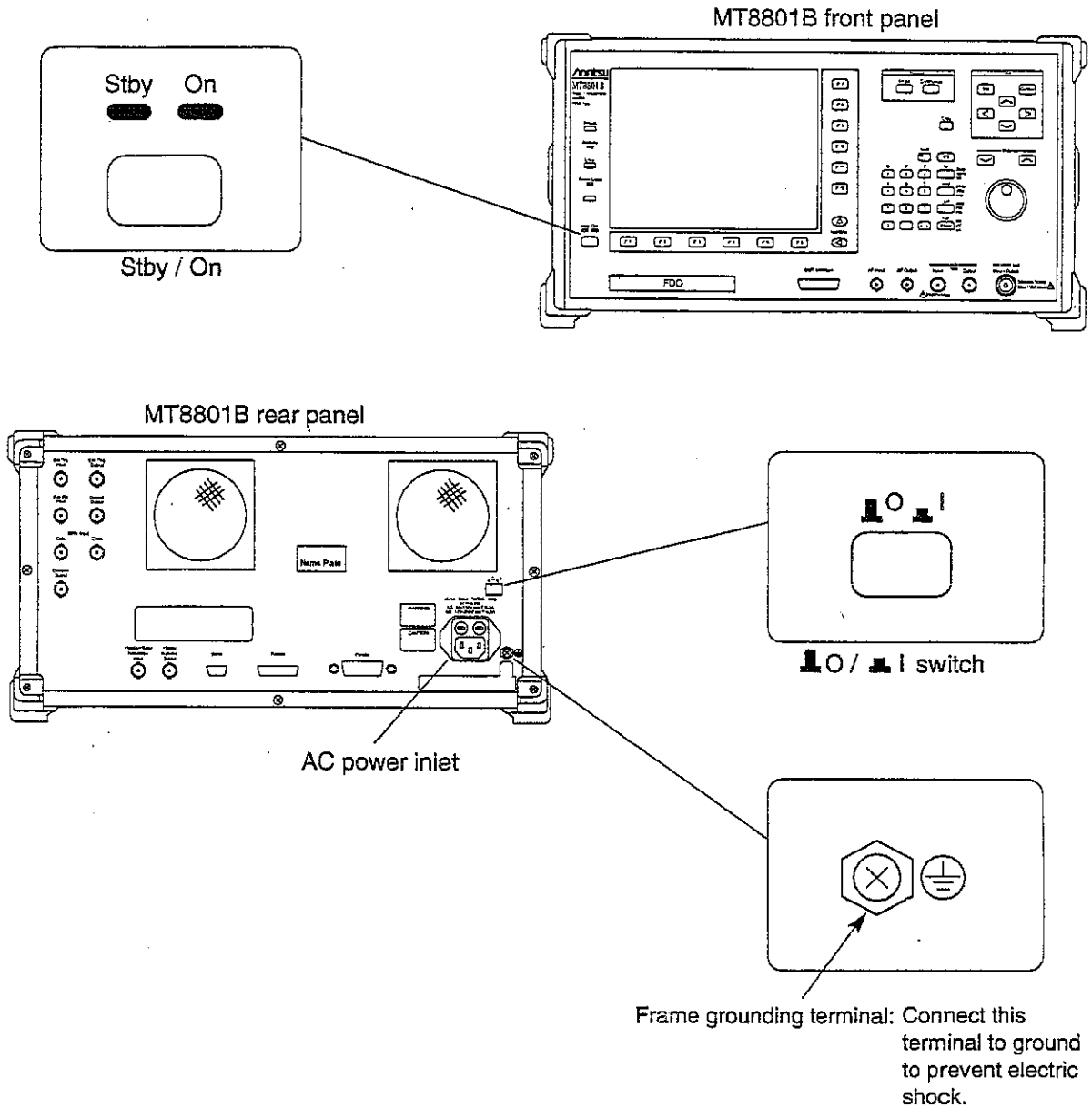

WARNING

• Protective grounding

If the power is turned on without protective grounding, operator runs the risk of electric shock. If the MT8801B does not have a three-pole (grounding type two-pole) power outlet, be sure to connect the frame grounding (FG) terminal on the rear panel or ground terminal of the accessory power cable to ground before turning on the MT8801B power.

CAUTION 

- Checking the power supply voltage

If the AC power supply voltage is improper, abnormal voltage may damage the mechanism inside the equipment. Confirm that the AC power supply voltage is within the specified rating before turning on the MT8801B power.

The following shows the specified power supply voltage and frequency:

Voltage: 85 to 132 Vac or 170 to 250 Vac (Because an automatic input voltage rating switching system is used, the rating need not be switched.)

Frequency: 47 to 63 Hz

For normal MT8801B operation, leave the power switch on the rear panel set to on when the AC power inlet is connected to the power outlet, and only use the Stby/On switch on the front panel to turn the power on and off.

Check the power display lamps at the lower-left part of the front panel as listed in the table below to confirm the power supply state.

Table 4.1 Power Display Lamp Indications and Power Supply States

Display lamp State	Power standby display lamp (green) (Stby)	Power on display lamp (orange) (On)
Main power off	Off	Off
Only main power on	On	Off
All power supplies on	Off	On

4.1.1 Turning on the Power

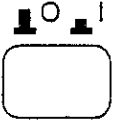

Perform the power-on procedure through warming up the internal reference oscillator to normal MT8801B operation in order of the following steps:

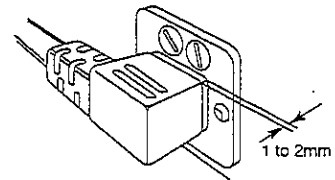
Step	Operation	Description
1.	Connect the frame grounding terminal on the rear panel to ground.	<ul style="list-style-type: none"> • When using a three-pole power cable with a grounding terminal, the MT8801B need not be grounded.
2.	 Set the O switch on the rear panel to O (Off).	<ul style="list-style-type: none"> • When the button is pressed down and set, it is (On). Press the button again to release it. When the button is set Off, the AC power is turned off even if the power switch on the front panel is set On.
3.	Connect the power cable jack to the AC power inlet on the rear panel.	<ul style="list-style-type: none"> • Fully insert the power cable jack so that there is a gap of 1 to 2 mm as shown in the figure below.
4.	Connect the power cable plug to the AC power outlet.	



Step	Operation	Description
------	-----------	-------------

5. Set the O I switch on the rear panel to I (On)

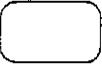

- The Stby lamp on the front panel power switch lights.  
- The reference crystal oscillator circuit built in the MT8801B starts to warm up. Before operating the MT8801B under low temperatures, warm up the crystal oscillator for 24 hours. The table below lists the stability of the crystal oscillator based on the warm-up time. 

Crystal oscillator stability

Item		Stability
Starting characteristics	After 30-minute operation	5×10^{-8} /day or less
Aging rate (after 24-hour operation)		2×10^{-8} /day or less
Stability at ambient temperature change of crystal oscillator ($25^{\circ}\text{C} \pm 25^{\circ}\text{C}$)		$\pm 5 \times 10^{-8}$ or less

6.  

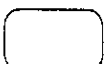

- The On lamp on the front panel power switch lights and the Stby lamp goes off.  
- Power is supplied to all circuits in the MT8801B, then the MT8801B becomes operable. 

Hold down the Stby/On switch on the front panel for a few seconds to set it On.

Notes: If neither power display lamp lights, check the following:

- Are the power cables properly connected to the power inlet and power plug?
- Are the specified fuses set in the fuse holders?
- Is the power supply voltage correct?

10MHz/13MHz
Reference
Input



10MHz
Buffered
Output



Notes: The left figure shows the reference signal input/output connectors on the MT8801B rear panel. The internal 10 MHz reference signal is output from the 10 MHz OUTPUT connector at TTL level. When the internal reference signal is not used, input an external reference signal satisfying the following conditions to the 10 MHz/13 MHz Reference Input connector:

- Frequency: 10 MHz ± 1 ppm, signal level: 2 to 5 Vp-p
- Frequency: 13 MHz ± 1 ppm, signal level: 2 to 5 Vp-p





Set the reference frequency on the Instrument Setup screen (see paragraph 4.3.1) according to the external reference signal used as described in i) and ii) above.

Warm up the external reference signal equipment separately from warming up the MT8801B.



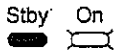

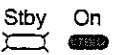
4.1.2 Turning off the Power

Turn off the power as described below.

(1) Normal power-off procedures

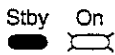
Step	Operation	Result check
1.	  Press the Stby/On switch on the front panel for a few seconds to set it to Stby state.	<ul style="list-style-type: none"> The On lamp of the Power switch on the front panel goes off, and the Stby lamp lights. Only the internal reference crystal oscillator is turned on.  

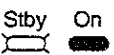
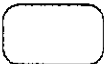
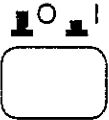
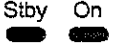
(2) Power-off procedures for storage or long stop

Step	Operation	Result check
1.	  Press the Stby/On switch on the front panel for a few seconds to set it to Stby state.	<ul style="list-style-type: none"> The On lamp of the power switch on the front panel goes off and the Stby lamp lights. Only the internal reference crystal oscillator is turned on.  
2.	 Set the O I switch on the rear panel to the I (off) position.	<ul style="list-style-type: none"> The AC power is turned off. Both the Stby and On lamps of the Power switch on the front panel go off. Only the internal reference crystal oscillator is turned on.  

4.1.3 Setup state after power-on

- The Setup Common Parameter screen is displayed shortly after power-on. At this time, parameters can be set by specifying Power-On Initial on the Instrument Setup screen.(See paragraph 4.3.3.)
- If a short power failure occurs, the power switch on the front panel goes Off. In this case, press the power switch On again.

4.2 Screen Descriptions

This paragraph describes the common items displayed on the screen.

(1) Screen layout

The composition of the measurement screen is described below.

- **Title display area**
The type MT8801B, and date (**_**_**) time (**:**:**), or user-defined character string (title) are displayed on the top left line. These are set on the Instrument Setup Screen.
- **Screen name display area**
The screen name (paragraph 3.2.2 (4)) and measurement system name(GMS) are displayed on the second line from the top left.
- **Measurement error messages display area**
Messages for errors generated during measurement are reverse displayed on the third line from the top left. There are 8 measurement error messages as follows. TX messages are shown in high priority order.

[TX measurement]

Priority

High	Input Level Over	RF input level exceeded the hardware limit.
↑	Level Over	Level too high
↓	Level Under	Level too low
↓	Signal Abnormal	Measurements cannot be carried out.
Low	Unique Word Not Found	Sync word cannot be detected

[RX measurement]

Pattern Sync Being Established

Pattern Sync Loss

Over Flow

Mesured data is over flowed.

- **RF input/output display**
"M" or "A" displayed on the first line from the top center indicates the RF connector used.
M: Main Input/Output
A: AUX Input/Output
- **Calibrated display**
If the MT8801B is already calibrated, "C" is displayed on the second line from the top center. This is appeared after executing calibration on the Modulation Analysis screen etc..
C: Calibrated
- **User calibration factor setting display**
If a user calibration coefficient is being set, "U" is displayed on the third line from the top center. This is appeared when the user Cal. factor is set to any value other than 0.00 dB at the Setup TX Measure Parameter screen.
U: User Cal. Factor

- Measurement mode display area

The measurement mode is displayed on the first line from the top center.

This is appeared depending on the Measure key (Continuous/Single).

Measure:	Continuous:	Continuous measurement
Measure:	Single:	Single (one time) measurement

In average storage mode, nothing is displayed in this area.

- Storage mode display area

The displayed value or waveform storage mode is displayed on the second line from the top right.

This is the setting value of the storage mode on the current measurement screen.

Storage:

Normal:	Normal display
Overwrite:	Trace data overwriting
Average :	Averaging
(order of storage operations performed and total number of operations)	
Wide dynamic range:	Wide dynamic range
Max Hold:	Maximum value held
Min Hold:	Minimum value held
Cumulative:	Dot data accumulation display

- Call Processing status display area

The current Call Processing status is displayed in the third line on the top right.

Call Processing:

Off:	Indicates that the DUT Control of the MT8801B is set to None on the Setup Common Parameter screen.
Stop:	Indicates that the DUT Control of the MT8801B is set to Call Proc on the Setup Common Parameter screen and that the Call Processing status is stopped.
Idle:	Indicates that the DUT Control of the MT8801B is set to Call Proc on the Setup Common Parameter screen and that the Call Processing status is ready.

Paging:

Radio Link:

Registration:

Originaton:

Termination:

Communication:	Indicates that the DUT Control of the MT8801B is set to Call Proc on the Setup Common Parameter screen and that the Call Processing status is Communication.
----------------	--

Hand Over

Disc from MS

Disc from NT

Radio Disc

- Menu display area

The titles of up to six main function keys (F1 to F6) are displayed horizontally along the bottom.

When the [Main Func on off] (F6) key on the right is set On, the main function menu is displayed.

When the [Main Func on off] (F6) key is set Off, the menu is displayed according to the screen contents.

Use the Next Menu [◀] key to display the next page.

The display of 1 (first page), 2 (second page), or later above the F6 menu indicates the current page.

The titles of up to six function keys (F7 to F12) are displayed vertically along the right side.

The display of 1 (first page), 2 (second page), or later under function key F12 indicates the menu page number.

The current page is reverse displayed. If there are multiple pages, use the Next Menu [▲] key to display the next page under the F12 key.

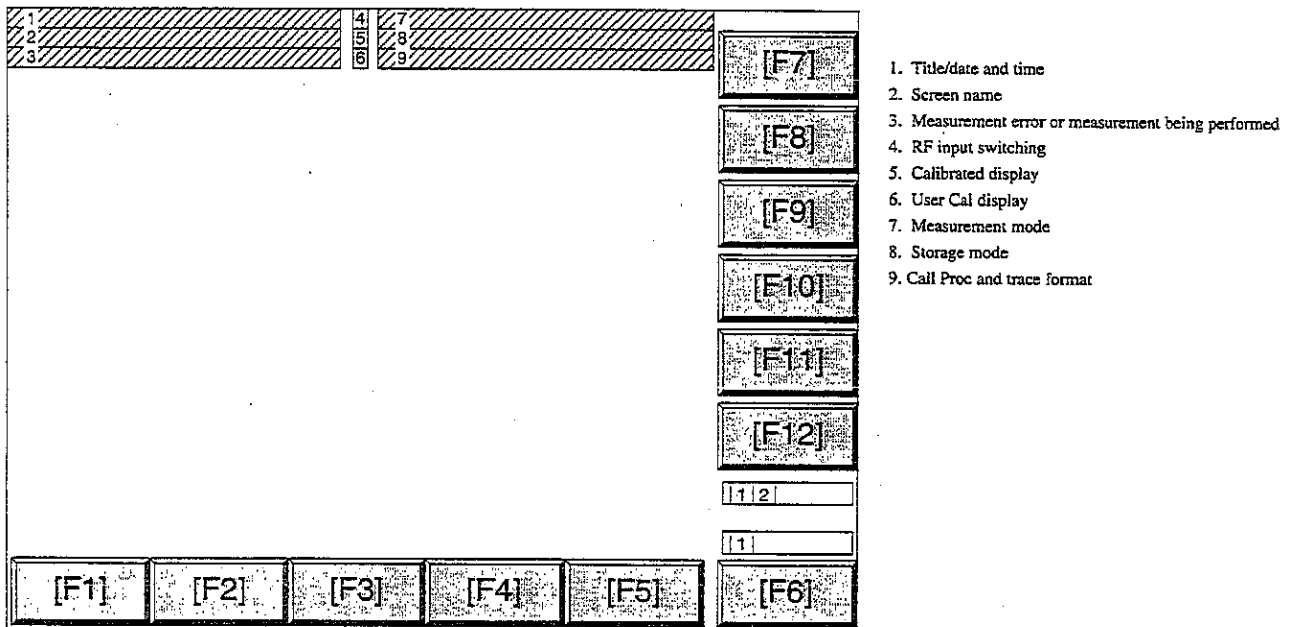

Fig. 4-1 Screen Layout

(2) Function keys

The symbols displayed on the top right of the function keys indicate the following functions:

*: Indicates a lower level function key is displayed when this function key is pressed.

->: Indicates the screen is changed by pressing this function key.

#: Indicates a window is opened to set a value using the ten-keypad, Step key, or rotary knob when this function key is pressed.

(a) Menu for transition to lower hierarchy screen

(The Back screen key switches the current screen to the higher hierarchy screen.)

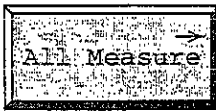

(b) Menu for transition to lower hierarchy menu



(c) Menu for opening the value setting window

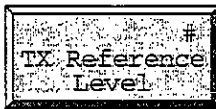

- Function key menu that select setting item:

One of the multiple selection keys (displayed in the same menu hierarchy) can be selected. The top and right frames of the selected key are reverse displayed. (See para. (e) below.)

The setting values displayed in a key are changed alternately. When such a key is selected, the set value is reverse displayed. (See para. (d) below.)

- (d) Menu on which set items are switched alternately (alternate key menu)



- (e) Menu on which a set item is selected

[Example of the function key menu]

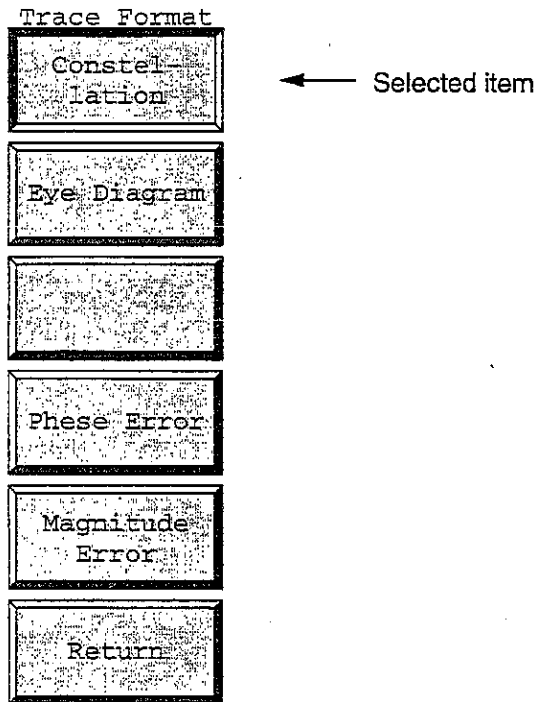

[Example of the main function key menu]



↑
Selected item

(3) Entering the data

(a) Entering numeric data by opening/closing the window

(i) Entering numeric data by moving the cursor and opening/closing the window

Move the cursor to the brackets enclosing the item to be set, then press the Set key. The value setting window shown below is opened and numeric data can be set.

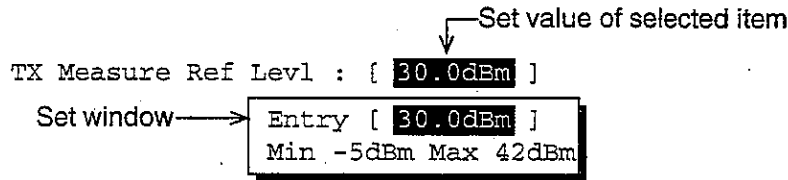

When a value is entered using the ten-keypad, Step key, or encoder, then press the unit or Set key, the numeric data is defined and the window is closed

If the Cancel key, a function key or main function key is pressed while the window is open, the window is closed and the previously set value is displayed.

(ii) Entering numeric data by pressing a function key or main function key

When the key marked # on the top right of the menu is pressed, the value setting window shown below is opened and numeric data can be set.

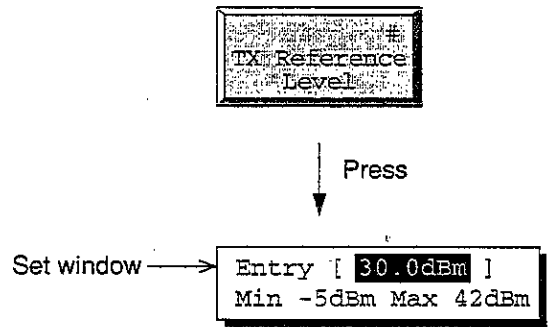

When a value is entered using the ten-key pad, Step key, or encoder, then press the unit or Set key, the numeric data is defined and the window is closed.

If the Cancel key, a function key or main function key is pressed while the window is open, the window is closed and the previously set value is displayed.

(b) Entering selection item by opening/closing the window

Move the cursor to the brackets enclosing the item to be set, then press the Set key. The selected item setting window shown below is opened and the selected item can be set.

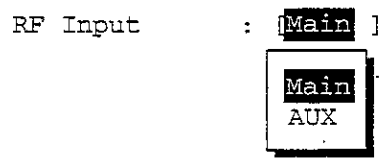

When an item in the window is selected using the cursor keys and the Set key is pressed, the set value is defined and the window is closed.

(c) Entering selected items using alternate keys

Selection items are displayed on the function key menu. Each time one of these keys is pressed, set values are switched alternately. The currently selected item is reverse displayed.



(d) Entering selected items using function keys with lower hierarchy

When the key marked * on the top right of the menu is pressed, the menu set of the lower hierarchy shown below is displayed.

Select an item from the menu set and press the corresponding function key. The menu display of the selected item is changed. When the return function key is pressed, display returns to the menu set of the higher hierarchy.

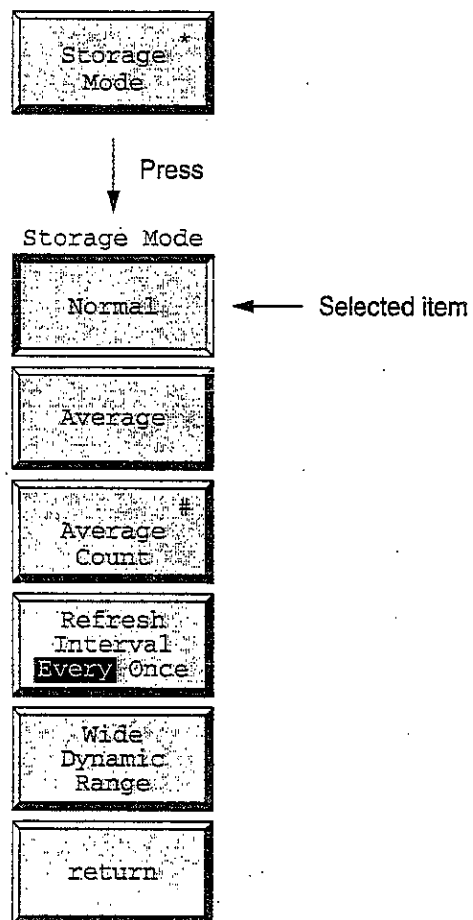

(e) Entering the title

See paragraph 4.3.3, "Instrument Setup screen."

4.3 GSM Transmitter and Receiver Test --- TX and RX Tester Mode

This paragraph describes operation when using the MT8801B in which MX880115A measurement software (GMS) is installed to measure the GSM transmitter and receiver.

4.3.1 Preparations

This paragraph describes the setup, zero-point calibration of the power meter, and RF cable loss correction when measuring the DUT.

(1) Setup

This following explains how to set the MT8801B and device under test (DUT) when conducting tests.

Setup:

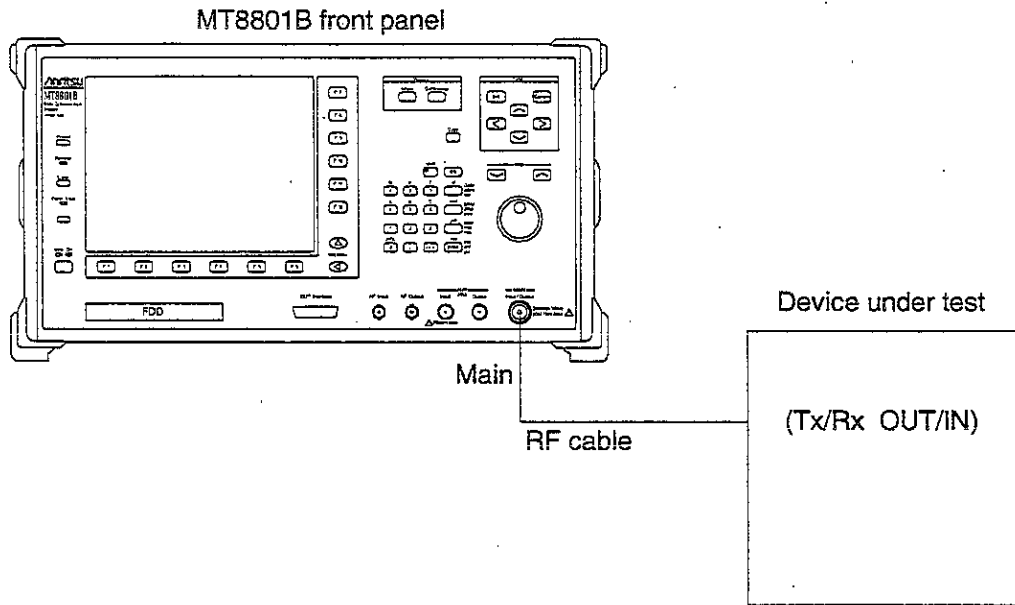

Fig. 4-2

[DUT Interface connector]

The DUT Interface connector is equipped on the bottom of the MT8801B front panel to transmit and receive signals for control and measurement. However, in the GSM system, the MT8801B controls the DUT using the Call Processing function, so does not use this connector.

(2) Calibration before measurement

The MT8801B has two types of power measurement functions.

For high precision measurements, calibrate the MT8801B as shown below.

(a) Power meter function

Press the [Power Meter] F12 key in TX/RX Tester mode to set the power meter function.

The power meter function uses a thermo-couple to measure the average power with high precision.

Calibrate the MT8801B at the zero power point for high-precision measurements.

Zero-point calibration: Disconnect anything from the Main Input/Output connector to set no input power, and press the [Zero Set] F11 key to automatically calibrate the power meter at the zero power point.

For details on operation, see Paragraph 4.3.6, (6) "Power Meter."

Note: The power meter function is effective only when the Main connector is used.

(b) Burst-power measurement function

Press the [RF Power] F9 key in TX/RX Tester mode to set the burst-power measurement function.

This function measures the on/off power, rise/fall times etc. of burst signals. For high precision measurement, internal calibration is required.

There are two types of internal calibrations of the Adjust Range and Manual Calibration, as described below.

Adjust Range: Optimizes the internal RF ATT, A/D input level, and power meter range of the MT8801B for the signal to be measured. This function can increase the measurement range for the on/off ratio and adjacent channel leak power.

Manual Calibration: Calibrates the measured power value in the RF Power screen using the MT8801B built-in power meter.

Pressing the Calibration Cancel key clears the calibration factor to 0 dB.

The calibration factor may become incorrect when the internal temperature rises, the ambient temperature changes, the measurement frequency changes etc.. For precise measurement of the TX power, perform Manual Calibration at that time.

For details on operation, see Paragraph 4.3.6 "Transmitter Test."

Notes:

1. Manual Calibration is effective only when the Main connector is used.
2. The Adjust Range and Manual Calibration run a common internal process in all TX measurement screens.
Once calibration is performed in any TX measurement screen, no more calibration is required in any other screen.
3. If the MT8801B input level is small or the input frequency does not match the setup frequency, the Adjust Range and Manual Calibration may not be performed properly.
4. Execute Adjust Range and Manual Calibration while the measurement signals are input stationary.
5. When performing Manual Calibration results in an error (corrected data cannot be generated), calibration factor of the Manual Calibration (held before the execution) is lost.

(3) Correcting RF cable loss when conducting the transmitter test (TX Measure mode): Setting User Cal Factor

When conducting the transmitter test (TX Measure mode), set the loss of the RF cable connecting the MT8801B and transmitter under test as a correction value (User Cal Factor) to measure RF power in the transmitter under test.

Step	Key operation	Description
1.	[Main Func on off]F6	Sets Main Func on to display the Main Menu at the bottom of the screen.
2.	[TX&RX Tester]F1	Sets TX&RX Tester mode. The Setup Common Parameter screen appears.
3.	[TX Measure]F1	Displays the first page of the TX Measure menu.
	Next Menu [▲]	Displays the second page of the TX Measure menu.
	[Setup TX Parameter]F9	Displays the Setup TX Measure Parameter screen.
4.	Cursor [↖] [↘]	Moves the cursor to User Cal Factor.
5.	[Set][-/+][0][1] to [F/9] [BS]	Enter the RF cable loss. Example: For 5dB loss, enter 5.00 dB.
6.	[Enter]	Defines the entered value.
7.	[Back Screen]F12	Returns to the Setup Common Parameter screen.

(4) Correcting RF cable loss when conducting the receiver test (RX Measure mode): Setting Offset Value

When conducting the receiver test (RX Measure mode), use the loss of the RF cable connecting the MT8801B and receiver under test as a correction value (Offset Value) to measure RF power in the receiver under test as follows.

Step	Key operation	Description
1.	[Main Func on off]F6	Sets the Main Func on to display the Main Menu at the bottom of the screen.
2.	[TX&RX Tester]F1	Sets the TX&RX Tester mode. The Setup Common Parameter screen appears.
3.	[RX Measure]F2	Displays the RX Measure menu.
	[Bit Error Rate]F7	Displays the Bit Error Rate screen.
4.	[Level]F3	Displays the first page of the Level menu.
	Next Menu [▲]	Displays the second page of the Level menu.
5.	[Offset Value]F7	Opens the Offset Value window.
6.	[-/+][0][1] to [F/9] [Shift/o] [BS]	Enter the RF cable loss. Example: For 5 dB loss, enter -5.00 dB.
7.	[Enter]	Defines the entered value.
8.	[Offset On Off]F8	Sets Offset On. Offset is displayed in the RF output level display field.
9.	[Back Screen]F12	Returns to the Setup Common Parameter screen.

4.3.2 Selecting and changing the measurement system: Change System screen

Change the measurement system according to the following steps.

For measurement after change, refer to the manual of the selected measurement system.

Step	Key operation	Description
1.	[Main Func on off]F6	Sets the Main Func on. The Main Menu appears at the bottom of the screen.
	Next Menu [◀]	Displays the second page of the Main Menu.
2.	[Change System]F1	Sets Change System mode. The Change System screen and System menu appear.

This screen is used to select anyone of measuring systems and to upgrade the system software.

Note: Changing any measuring system in this screen initializes the corresponding measurement parameters. Save the parameters before changing if necessary.

(1) Changing the built-in measuring system

This paragraph describes how to exchange the measuring system used when more than one measuring systems are built in the MT8801B.

Step	Key operation	Description
1.		Make sure that "Current System" shows the system currently selected and that "Application Memory" contains a new measuring system to select.
2.	[Change System] F7	Sets Change System mode. Displays one of the measuring system softwares in the "Application Memory" in reverse display.
3.	Cursor [^] [v]	Select one of the measuring system softwares in the "Application Memory".
4.	Set	Confirms the measuring system software.

(2) Loading measuring systems from an external floppy disk

This paragraph describes how to load measuring systems from an external floppy disk.

(This function is effective only when the measuring software floppy disk is used.)

Step	Key operation	Description
1.		Set the floppy disk containing measuring system files in the floppy disk driver of the MT8801B.
2.	[Floppy Disk Dir] F8	Displays measuring system files on the floppy disk. Here, confirm the "Unused area" under "Application Memory", and also the size of the measuring systems on the floppy disk. The measuring systems can be loaded when the value in "Unused area" is greater than size of measuring systems to be loaded.
3.	[Install system form FD] F10	Loads measuring system from the floppy disk to "Application Memory."
4.	Set	Make sure that the measuring systems are displayed(saved) in "Application Memory."

4.3.3 Setting the measurement system conditions: Instrument Setup screen

Set the standard frequency of the measurement system (10 MHz or 13 MHz), RF connector (Main or AUX), screen title/date/time display, interface (GPIB or RS232C), printer (ESC/P), and alarm (on or off) on this screen.

Procedure for transition to the Instrument Setup screen

Step	Key operation	Description
1.	[Main Func on off]F6	Set Main Func on. The Main Menu appears at the bottom of the screen.
	Next Menu [◀]	Displays the second page of the Main Menu.
2.	[Instrument Setup]F2	Sets Instrument Setup mode. The Instrument Setup screen appears. The Instrument Setup function key menu appears on F7 to F12.

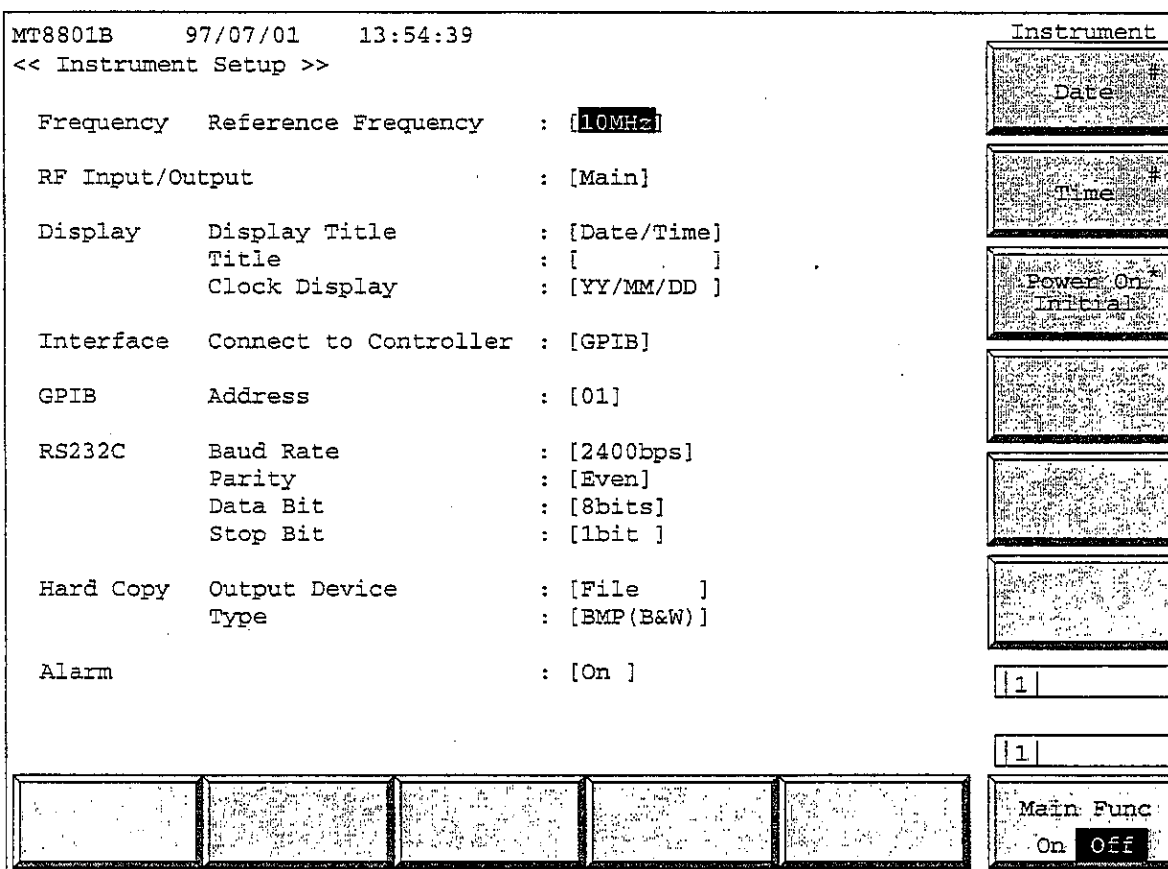

Fig. 4-3 Instrument Setup Screen

- Set the following items:

Item	Range	Initial value
Frequency		
Reference Frequency	10MHz, 13MHz	10MHz
RF Input/Output	Main, AUX	Main
Display		
Display Title	User Define, Date/Time, Off	User Define
Title	User Define, Date/Time, Off (32 alphanumeric characters) (*1)	
Clock Display	YY/MM/DD (year, month, day) MM-DD-YY (month, day, year) DD-MM-YY (day, month, year)	YY/MM/DD (year, month, day)
Interface		
Connect to Controller	GPIB, RS232C	GPIB
GPIB		
Address	00 to 30	01
RS232C		
Baud Rate	1200, 2400, 4800, 9600(bps)	2400
Parity	Even, Odd, Off	Even
Data Bit	7 bits, 8 bits	8 bits
Stop Bit	1 bit, 2 bits	1 bit
Hard Copy		
Output device	Printer (Parallel), File	Printer (Parallel)
Type	ESC/P, HP2225... for Printer (Parallel) BMP (B&W)... for File	ESC/P
Alarm	On, Off	On

*1 Entering the title:

A title up to 32 characters can be entered in the title display area. (User Define)

MT8801B**_**_**(date)**:**:(time) is displayed as an initial value. (Date/Time)

Enter a title according to the following steps. (User Define)

Step	Key operation	Description
1.	Cursor [^] [v]	Moves the cursor to the Title entry area.
2.	[Set]	Opens the Title entry window.
3.	Step [^] [v]	Moves the cursor into position in the Title entry area to enter character.
4.	Cursor [<] [>]	Select a character.
5.	[Enter]	Defines the character.
6.	[BS]	Correct any incorrect character.
7.		Repeat steps 3 to 6 to enter all characters in the Title entry area.
8.	[Set]	Defines the entered character string.

- Function keys

Main function key: None

Function keys:

[Date]F7: Opens the date entry window.

[Time]F8: Opens the time entry window.

[Power On Initial]F9: Displays the Power On menu to select Initialization modes, which are classified into Previous Status and Recall File.

Initial value: Previous Status

When Previous Status mode is selected, the parameters after power-on retain the status held before the previous power-off.

When Recall File mode is selected, the parameters after power-on are set by reading the specified file.

[Previous Status]F7: Sets the parameters after power-on to the status held before the previous power-off.

[Recall File]F8: Accesses the floppy disk to call the parameter file list.

[File No.]F9: Opens the parameter-file setting-location (number) entry window.

File No.: 0 to 99, Initial value: 0

[return]F12: Returns to the previous menu.

- Selecting Power On Initial mode

The following describes how to select parameter initialization mode after power-on.

1. Selecting Previous Status mode

Step	Operation
1.	Press the [Power On Initial] F9 key.
2.	Press the [Previous Status] F7 key.
3.	Press the [return] F12 key to define the parameters then return to the previous menu.

2. Selecting Recall File mode (being developed)

Step	Operation
1.	Press the [Power On Initial] F9 key.
2.	Set the floppy disk (on which parameters to be read before power-on are written) in the floppy disk drive.
3.	Press the [Recall File] F8 key. (Access the floppy disk to call the parameter list file.)
4.	Display the parameter file to be set on the screen.
5.	Press the [File No.] F9 key. (Open the parameter-file setting-location [number] window.)
6.	Enter the number of the parameter file to be set.
7.	Press the [Set] key to define the parameters, then press the [return] F12 key to return to the previous menu.

- Notes:
- If no floppy disk is set before power-on or a floppy disk other than that used at setting is used, parameters may be set in Previous Status mode or different parameters may be set.
 - The ambient temperature range of the floppy disk is specified as 5 to 45 °C. If a set temperature is outside the specified range, operation is not guaranteed.

- Changing the time and date of the built-in clock

1. Changing the date

Step	Operation
1. [Date] F7	Opens the date setting window. Displays the current date and time of the built-in clock.
2. Cursor [^] [v]	Moves the cursor to the part to be changed.
3. [Set]	Opens the setting window.
4. 0 to 9, [BS]	Sets the data.
5. [Set]	Closes the setting window and establishes the set value.

2. Changing the time and date of the built-in clock

Step	Operation
1. [Date] F7	Opens the time setting window. Displays the current time of the built-in clock.
2. Cursor [^] [v]	Moves the cursor to the part to be changed.
3. [Set]	Opens the setting window.
4. 0 to 9, [BS]	Sets the data.
5. [Set]	Closes the setting window and establishes the set value.

Note: To stop changing the date or time of the built-in clock

To stop changing the date or time after opening the setting window of the built-in clock, press the [Cancel] key in the above Step 4 or 5 (do not use the [Set] key). If the [Set] key is pressed again after the date and time window is opened, the value on the setting window is set again. The date and time window remains in the state when the window was opened. Therefore, if the [Set] key is pressed without changing the display on the window, the date and time of the built-in clock are delayed.

4.3.4 Setting the screen display color: Change Color menu

To set a screen color, display the Change Color menu as follows.

(The F7 to F12 function keys menu changes to the Change Color menu, but the screen does not change.)

Step	Key operation	Description
1.	[Main Func on off]F6	Sets Main Func on. The Main Menu appears at the bottom of the screen.
	Next Menu [◀]	Displays the second page of the Main Menu.
2.	[Change Color]F3	Sets Change Color mode. The Change Clr. function key menu appears on F7 to F12.
3.		Use the function key on the next page to set a color.
4.	[return]F12	Returns to the previous menu.

• Function keys

Main function key:	None
Function keys:	
Change Color menu:	Initial value: Color Pattern 1
[Color Pattern 1] F7:	Selects Anritsu-specified color 1.
[Color Pattern 2] F8:	Selects Anritsu-specified color 2.
[Color Pattern 3] F9:	Selects Anritsu-specified color 3.
[Color Pattern 4] F10:	Selects Anritsu-specified color 4.
[Define User Color] F11:	Displays the Define Clr. menu to set a user-specified color.
[Copy Color Ptn from] F7	Displays the [Copy from] menu to select an Anritsu-specified color as an original color to set a user-specified color.
[Color Pattern 1] F7:	Selects Anritsu-specified color 1 as an original color.
[Color Pattern 2] F8:	Selects Anritsu-specified color 2 as an original color.
[Color Pattern 3] F9:	Selects Anritsu-specified color 3 as an original color.
[Color Pattern 4] F10:	Selects Anritsu-specified color 4 as an original color.
[return] F12:	Returns to the previous menu.
[Select Item frame **] F8:	Selects the screen configuration field to set a display color. Use a number ** from 0 to 16 for this setting. The number increases in step of one by pressing this key.
[Red *] F9:	Set red intensity of the item frame selected by F8.
[Green *] F10:	Set green intensity of the item frame selected by F8.
[Blue *] F11:	Set blue intensity of the item frame selected by F8.
[return] F12:	Returns to the previous menu.
[return] F12:	Returns to the previous menu.

• Relation between screen assignment and number ** in [Select Item Frame **] F8 key

[Select Item Frame 0]	Back-screen of function keys
[Select Item Frame 1]	Back-screen of the main function keys
[Select Item Frame 2]	Display frame of function and main function keys
[Select Item Frame 3]	Characters and display frame of function and main function keys
[Select Item Frame 4]	Back-screen of waveform display
[Select Item Frame 5]	Scale line and frame of waveform display
[Select Item Frame 6]	Waveform display (1)
[Select Item Frame 7]	Waveform display (2)
[Select Item Frame 8]	Display other than function and main function keys
[Select Item Frame 9]	Characters right over the main function keys
[Select Item Frame 10]	Measurement execution error display
[Select Item Frame 11]	Template and zone frames
[Select Item Frame 12]	Marker
[Select Item Frame 13]	Window back-screen
[Select Item Frame 14]	Window shade and characters
[Select Item Frame 15]	(Not used)
[Select Item Frame 16]	Back-screen

4.3.5 Setting the common measurement parameters: Setup Common Parameter screen

- Switch to the Setup Common Parameter screen according to the following steps.

Set common measurement conditions on this screen.

Step	Key operation	Description
1.	[Main Func on off]F6	Sets the Main Func on to display the Main Menu at the bottom of the screen.
2.	[TX&RX Tester]F1	Sets TX&RX Tester mode The Setup Common Parameter screen appears.
3.	[TX Measure]F1 [RX Measure]F2 [Call Processing]F3	The TX Measure (for transmitter test) function keys appear on F1 to F12. The RX Measure (for receiver test) function keys appear on F1 to F12. The Call Processing (for Sequence Monitor) function keys appears on F1 to F12.

The screenshot displays the 'Setup Common Parameter (GSM)' screen. The top status bar shows 'MT8801B 97/07/01 11:37:00 Call Proc: Stop'. The main area contains the following settings:

- System Combination : [GSM]
- DUT Control : [Call Proc]
- Frequency
 - Control Channel : [1CH] (=935.200000MHz)
 - Channel & Frequency : [1CH] = TX Meas. [890.200000MHz]
 - RX Meas. [935.200000MHz]
- Level
 - MS Power Level : [8]
 - TX Measure Ref Level : [30.0dBm]
 - RX Measure Output Level : [-55.0dBm] [Off]
- Signal
 - Measuring Object : [MS-NB]
 - TCH Slot : [2]
 - TS : [TSC0] (=0970897)
 - Timing Advance : [0bit]

At the bottom, there are two rows of function keys. The left row includes 'TX Measure', 'RX Measure', 'Call Processing', and two empty keys. The right row includes 'Main Func On Off' (with 'Off' selected) and another 'Main Func On Off' (with 'Off' selected). A large 'GSM' logo is centered at the bottom of the screen.

Fig. 4-4 (1/3) Setup Common Parameter Screen (TX Measure)

- The 2nd page of the main function keys on the Setup Common Parameter screen (TX Measure)

(1) When the MT8801B is the Call Processing status of Stop:

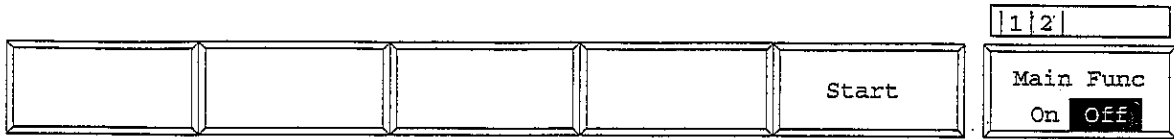

(2) When the MT8801B is the Call Processing status of Start, and the MS is the Call Processing status of Idle:

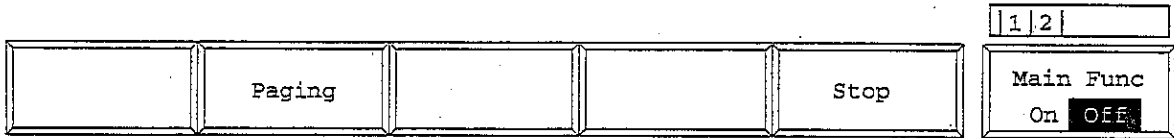

(3) When the MT8801B is the Call Processing status of Start, and the MS is the Call Processing status of Paging, Radio Link, Registration, Origination, Termination, Hand Over, Disc from MS or Radio Disc.

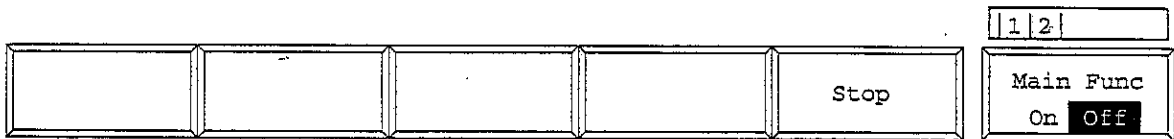

(4) When the MT8801B is the Call Processing status of Start, and the MS is the Call Processing status of Communication:

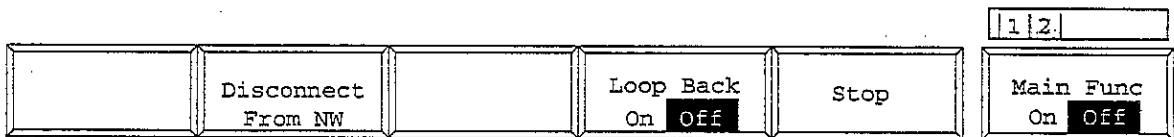

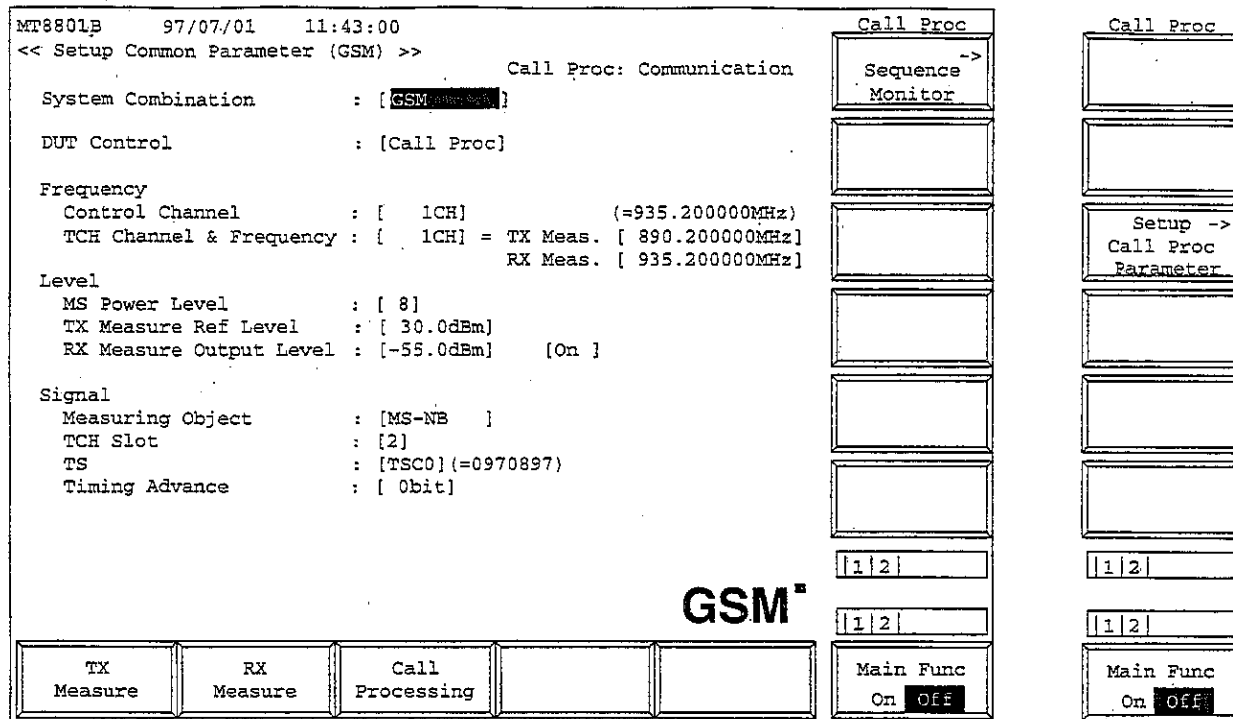
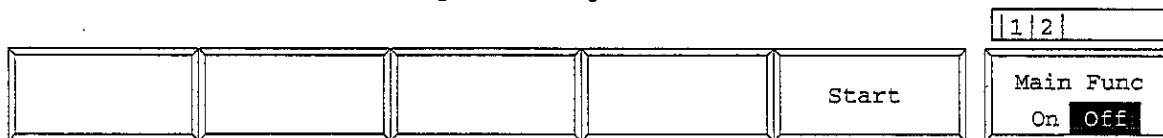

Fig. 4-4 (3/3) Setup Common Parameter Screen (Call Processing)

- The 2nd page of the main function keys on the Setup Common Parameter screen (Call Processing)

(1) When the MT8801B is the Call Processing status of Stop:



(2) When the MT8801B is the Call Processing status of Start, and the MS is the Call Processing status of Idle:

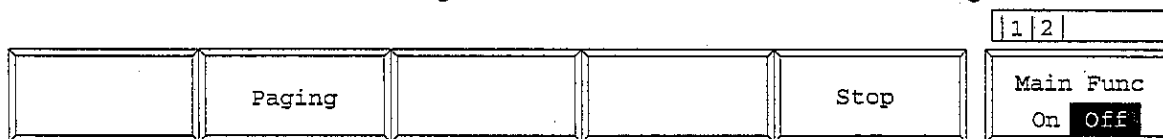

(3) When the MT8801B is the Call Processing status of Start, and the MS is the Call Processing status of Paging, Radio Link, Registration, Origination, Termination, Hand Over, Disc from MS or Radio Disc.

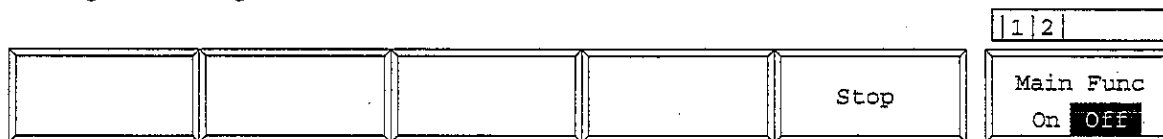

(4) When the MT8801B is the Call Processing status of Start, and the MS is the Call Processing status of Communication:

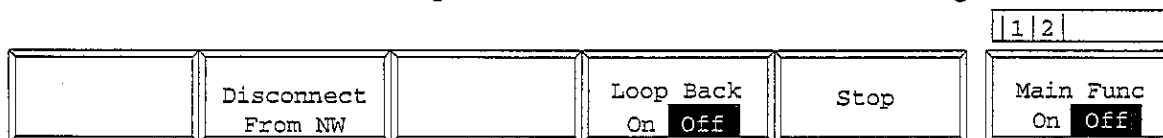

Note: The setup items for Signal (TCH Slot, TS and Timing Advance) do not appear when the Measuring Object is set to CONTINUOUS.

- Set the following items:

Item	Range	Initial value	
System Combination	GSM, GSM/DCS1800, GSM/PCS1900	GSM	
DUT Control	Call proc, None	None	
Channel & Frequency			
Control Channel	0 to 9999	1	
TCH Channel & Frequency			*1
TCH Channel	0 to 9999	1	
TX Meas. (Frequency)	0.3 to 3000MHz	890.200 000 MHz	*1
RX Meas. (Frequency)	0.3 to 3000MHz	935.200 000 MHz	*1
Level			
MS Power Level	0 to 31	8	*2
TX Measure Ref Level	-5.0 to +42.0 dBm(Main) -30.0 to +22.0 dBm(AUX)	+30.0 dBm +22.0 dBm	
RX Measure Output Level	-143.0 to -28.0 dBm(Main) -143.0 to -3.0 dBm(AUX)	-55.0 dBm -55.0 dBm	*1,*3
Signal			
Measuring Object	MSNB, CONTINUOUS	MSNB	*1
TCH Slot	0 to 7	0	
TS	TSC0,TSC1,TSC2,TSC3, TSC4,TSC5,TSC6,TSC7	TSC0	*5
Timing Advance	0 to 63 bits	0 bits	

*1: When the DUT Control is set to Call Proc, the Measuring Object is MS-NB and the TX Measure Frequency and RX Measure Frequency is set to the values corresponding to the CH (channel). The TCH Slot can be set to a value between 2 and 6.

*2: The MS Power Level setting value and the output level (dBm) from the MS

MS Power Level	Output Level from MS (dBm)		
	GSM	DCS1800	PCS1900
0	-	30	30
1	-	28	28
2	39	26	26
3	37	24	24
4	35	22	22
5	33	20	20
6	31	18	18
7	29	16	16
8	27	14	14
9	25	12	12
10	23	10	10
11	21	8	8
12	19	6	6
13	17	4	4
14	15	2	2
15	13	0	0
16	11	-	-
17	9	-	-
18	7	-	-
19	5	-	-
20	-	-	-
21	-	-	-
22	-	-	-
23	-	-	-
24	-	-	-
25	-	-	-
26	-	-	-
27	-	-	-
28	-	-	-
29	-	36	-
30	-	34	-
31	-	32	-

*3: When the main function key [Stop]F5 is pressed to stop the MT8801B, the RX Measure Output Level is set to OFF. Further, when the main function key [Start]F5 is pressed to set the MT8801B Call Processing to the Idle state, the RX

Measure Output Level (set value when the MT8801B is in the Stop state) is actually output from the MT8801B.

*4: The setup items for Signal (TCH Slot, TS and Timing Advance) do not appear when the Measuring Object is set to CONTINUOUS.

*5: The following shows the actual values for TSC0 to TSC7.

TSC0 0970897
TSC1 0B778B7
TSC2 10EE90E
TSC3 11ED11E
TSC4 06B906B
TSC5 13AC13A
TSC6 29F629F
TSC7 3BC4BBC

The following shows the cases where the setup is enabled or disabled depending on the Call Processing status.

- List of settable items for each status

O: enabled X: disabled and opens error-message window.

	DUT Control/None	DUT Control/Call proc MT8801 Stop	DUT Control/Call proc Status 0	DUT Control/Call proc Status 1	DUT Control/Call proc Status 2
System Combination	O	O	X	X	X
DUT Control (Call proc/None)	O	O	O	O	O
Contrl Channel	O	O	O	X	X
TCH Channel	O	O	O	X	O
TCH TX Meas.Freq.	O	X	X	X	X
TCH RX Meas.Freq.	O	X	X	X	X
MS Power Level	O	O	O	X	O
TX Ref Level	O	O	O	X	O
RX Output Level	O	O	O	X	O
RX Level On/Off	O	X	X	X	X
Measuring Object	O	X	X	X	X
TCH Slot	O	O	O	X	O
TS	O	O	X	X	O
Timing Advance	O	O	O	X	O

status0 = Idle

status1 = Paging, RadioLink, Registration, Origination, Termination, Hand Over, Disc from NT,
Disk from MS, Radio Disc

status2 = Communication

- 1st Page of main function keys

[TX Measure]F1

Displays the TX Measure (for transmitter test) function keys for F1 to F12.

[RX Measure]F2

Displays the RX Measure (for receiver test) function keys for F1 to F12.

[Call Processing]F3

Displays the Call Processing (for call-processing sequence monitor) function keys for F1 to F12.

- 2nd Page of TX Measure main function keys

[Paging]F2

Pages the MS.

[Disconnect from NT]F2

Disconnects the MS from network side (MT8801B).

[Loop Back On Off]F4

Turns on/off the MS loop-back state.

[Start]F5

Changes the MT8801B from Stop state to Start state.

[Stop]F5

Changes the MT8801B from Start state to Stop state.

- 2nd Page of Call Processing main function keys

[Paging]F2

Pages the MS.

[Disconnect from NT]F2

Disconnects the MS from network side (MT8801B).

[Loop Back On Off]F4

Turns on/off the MS loop-back state.

[Start]F5

Changes the MT8801B from Stop state to Start state.

[Stop]F5

Changes the MT8801B from Start state to Stop state.

SECTION 4 OPERATION

- TX Measure function keys

1st page

- [All Measure→]F7 Displays the All Measure screen.
- [Modulation Analysis→]F8 Displays the Modulation Analysis screen.
- [RF Power→]F9 Displays the RF Power screen.
- [Output RF Spectrum→]F11 Displays the Output RF Spectrum screen.
- [Power Meter→]F12 Displays the Power Meter screen.

2nd page

- [Select All Measure Item→]F7 Displays the Select All Measure Item screen.
- [Setup TX Parameter→]F9 Displays the Setup TX Parameter screen.

- RX Measure function keys

1st page

- [Bit Error Rate→]F7 Displays the Bit Error Rate screen.

2nd page

- [Setup RX Parameter→]F9 Displays the Setup RX Parameter screen.

- Call Processing function keys

1st page

- [Sequence Monitor→]F7 Displays the Sequence Monitor screen.

2nd page

- [Setup Call Proc Parameter→]F9 Displays the Setup Call Processing Parameter screen.

4.3.6 Transmitter test: TX Measure mode

This paragraph describes the following transmitter test items:

1. Setting parameters (Setup TX Measure Parameter screen) and all item measurement (All Measure screen) items (Select All Measure Item screen)
2. All item measurement (All Measure screen)
3. Modulation analysis [1] (Modulation Analysis screen: Value display)
Modulation analysis [2] (Constellation screen, Eye Diagram screen, Phase Error screen, Magnitude Error screen: Waveform display of 4 screens)
4. TX RF power (burst amplitude) measurement (RF Power screen, Setup Template screen)
5. RF output spectrum measurement (Output RF Spectrum screen)
6. TX RF power (average) measurement (Power Meter screen)

(1) Setting the parameters: Setup TX Measure Parameter screen

This paragraph describes how to set parameters (Setup TX Measure Parameter screen) to conduct the transmitter test (TX Measure mode).

(a) Setting the parameters: Setup TX Measure Parameter screen

- Switch to the Setup TX Measure Parameter screen according to the following steps:

Step	Key operation	Description
1.	[Main Func on off]F6	Sets Main Func on to display the Main Menu at the bottom of the screen.
2.	[TX&RX Tester]F1	Sets the TX&RX Tester mode. The Setup Common Parameter screen appears.
3.	[TX Measure]F1	Displays the first page of the TX Measure menu.
4.	Next Menu [▲]	Displays the second page of the TX Measure menu.
5.	[Setup TX Parameter]F9	Displays the Setup TX Measure Parameter screen.

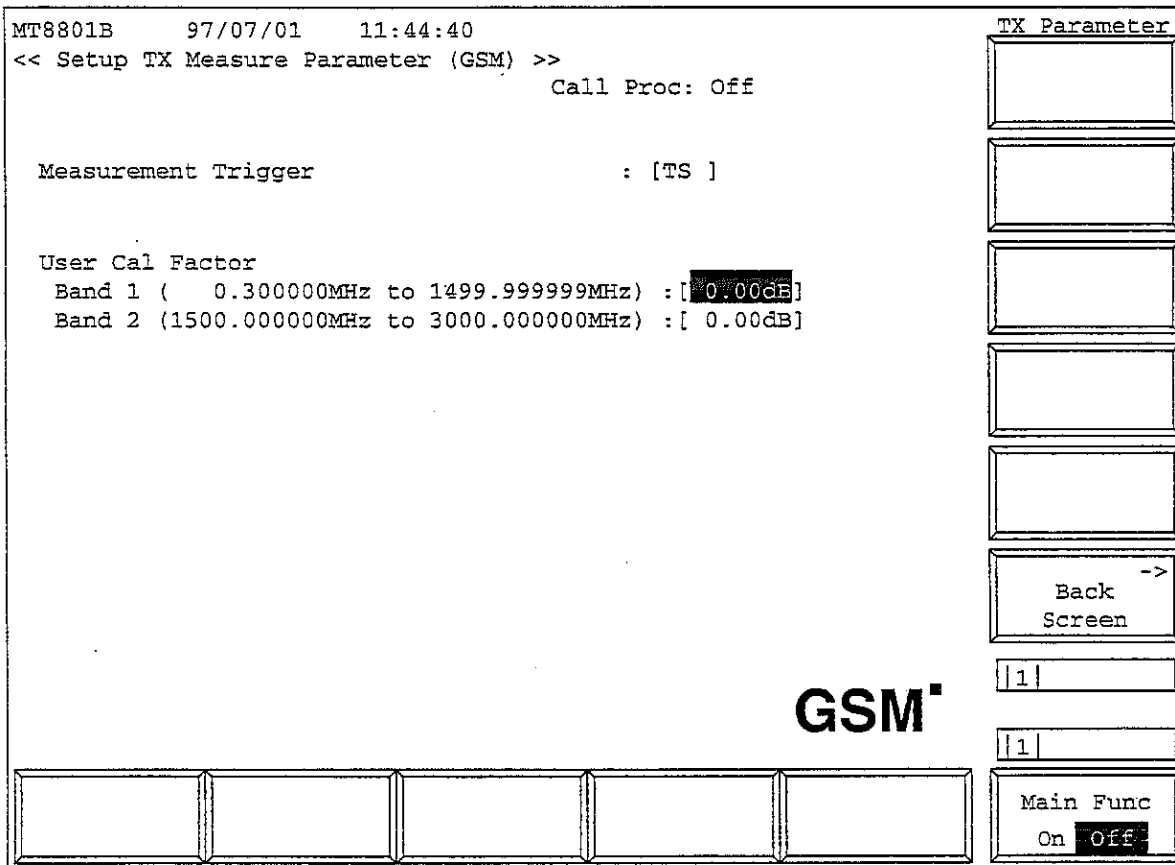

Fig. 4-5 Setup TX Measure Parameter Screen

Note: The setup item of Measurement Trigger does not appear when the DUT Control is set to Call Proc.

- Set the following items:

Item	Range	Resolution	Initial value
Measurement Trigger	TS, VIDEO		TS
User Cal Factor (User-level calibration value)			
Band 1 (0.3 MHz to 1499.999999 MHz)	-30.00 to 30.00 dB	0.01 dB	0.00 dB (*1)
Band 2 (500 MHz to 3000 MHz)	-30.00 to 30.00 dB	0.01 dB	0.00 dB (*1)

- *1 The value obtained from the following equation is displayed as an RF level measurement result:
 Displayed measurement result value = Measured value + User Cal Factor
 For User Cal Factor, the loss in the RF cable connecting the MT8801B and device under test is set as a correction value. (See paragraph 4.3.1, (2))

- Function keys

Main function key:	None
Function key:	TX Parameter
[Back Screen] (F12):	Displays the previous screen.

(b) Setting items for all item measurement of the transmitter: Select All Measure Item screen

- Switch to the Select All Measure Item screen according the following steps:
Set all item measurement (All Measure screen) items on this screen.

Step	Key operation	Description
1.	[Main Func on off]F6	Sets the Main Func on to display the Main Menu at the bottom of the screen.
2.	[TX&RX Tester]F1	Sets TX&RX Tester mode. The Setup Common Parameter screen appears.
3.	[TX Measure]F1	Displays the first page of the TX Measure menu.
4.	Next Menu [▲]	Displays the second page of the TX Measure menu.
5.	[Select All Measure Item]F7	Displays the first page of the Select All Measure Item screen.
6.	[Next Page]F8	Displays the second page of the Select All Measure Item screen.

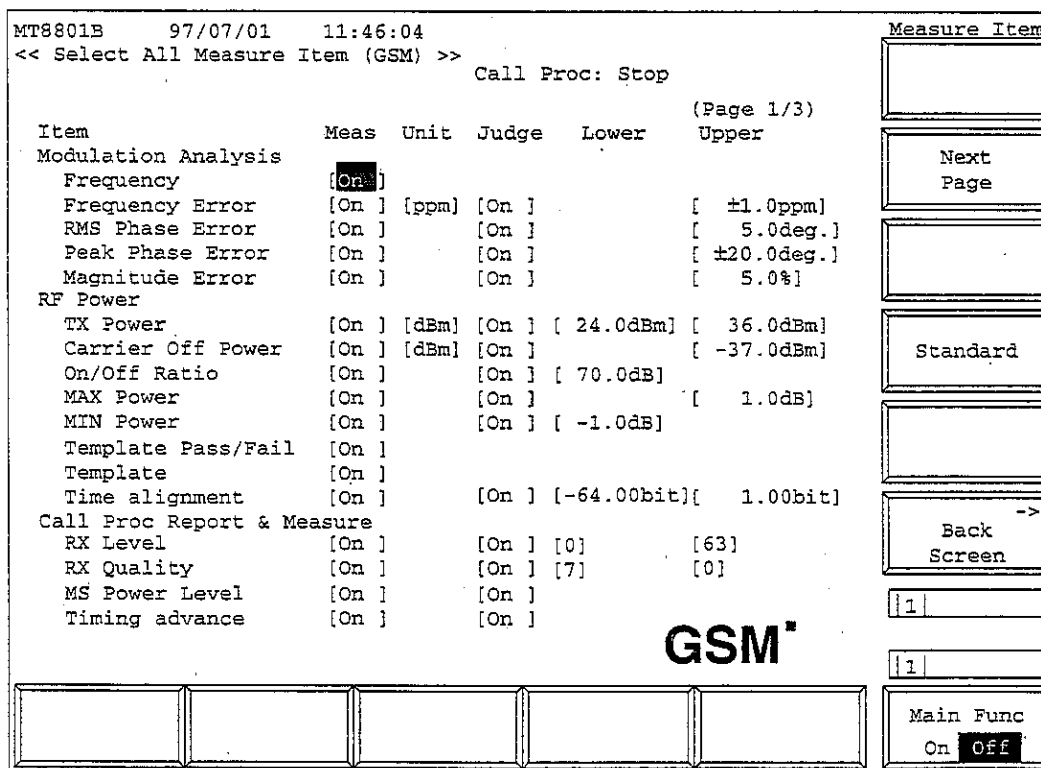

Fig. 4-6 Select All Measure Item Screen (First Page)

Note: The setup items of Call Proc Report & Measure (RX Level, RX Quality and Timing Advance) do not appear when the Call Proc is set to None.

MT8801B 97/07/01 11:46:26
 << Select All Measure Item (GSM) >> Call.Proc: Stop

(Page 2/3)

Item	Meas	Unit	Judge	Lower	Upper
RF Power vs Time (MS-NB)					
Time					
-28.0µs	[On]		[On]	[-110.0dB]	[-70.0dB]
-18.0µs	[On]		[On]	[-110.0dB]	[-30.0dB]
-10.0µs	[On]		[On]	[-110.0dB]	[-6.0dB]
-5.0µs	[On]		[On]	[-110.0dB]	[4.0dB]
0.0µs	[On]		[On]	[-1.0dB]	[1.0dB]
542.8µs	[On]		[On]	[-110.0dB]	[1.0dB]
547.8µs	[On]		[On]	[-110.0dB]	[1.0dB]
552.8µs	[On]		[On]	[-110.0dB]	[-6.0dB]
560.8µs	[On]		[On]	[-110.0dB]	[-30.0dB]
570.8µs	[On]		[On]	[-110.0dB]	[-70.0dB]

GSM

Measure Item
 Previous Page
 Next Page
 Standard
 Back -> Screen
 1
 1
 Main Func
 On Off

Fig. 4-7 Select All Measure Item Screen (Second Page)

MT8801B 97/07/01 11:46:43
 << Select All Measure Item (GSM) >>

(Page 3/3)

Item	Meas	Unit	Judge	Lower	Upper
Output RF Spectrum					
Modulation					
Switching Transients (dB)					
Offset Frequency (dBm)					
0 kHz	[On]		[On]		[30.0dB]
± 100 kHz	[On]	(dBm)	[On]	[0.5dB]	[30.0dB]
± 200 kHz	[On]		[On]	[-30.0dB]	[10.0dB]
± 250 kHz	[On]		[On]	[-33.0dB]	[0.0dB]
± 400 kHz	[On]		[On]	[-60.0dB]	[-17.0dB]
± 600 kHz	[On]		[On]	[-60.0dB]	[-26.0dB]
± 800 kHz	[On]		[On]	[-60.0dB]	[-26.0dB]
±1000 kHz	[On]		[On]	[-60.0dB]	[-26.0dB]
±1200 kHz	[On]		[On]	[-60.0dB]	[-32.0dB]
±1400 kHz	[On]		[On]	[-60.0dB]	[-32.0dB]
±1600 kHz	[On]		[On]	[-60.0dB]	[-32.0dB]
±1800 kHz	[On]		[On]	[-60.0dB]	[-36.0dB]
±2000 kHz	[On]		[On]	[-60.0dB]	[-36.0dB]

GSM

Measure Item
 Previous Page
 Standard
 Back -> Screen
 1
 1
 Main Func
 On Off

Fig. 4-8 Select All Measure Item Screen (Third Page)

Note: If the unit of Upper (Switch) is set to dB, the indications of Meas, Judge and Upper(Switch) at 0-kHz Offset Frequency do not appear (non-definable).

SECTION 4 OPERATION

- Set items in the following ranges: (* indicates the initial value.)

Item	Measurement On/Off	Unit (*1)	Judge On/Off	Lower lower limit value	Upper upper limit value
1st page					
Modulation Analysis					
Frequency	On*, Off	(MHz)			
Frequency Error	On*, Off	kHz,ppm*	On*, Off		±0.000 to 100.000 kHz(Unit: kHz) (* 2) ±0.0 to 100.0 ppm, 0.1 ppm*(Unit: ppm)
RMS Phase Error	On*, Off	(deg)	On*, Off		0.0 to 100.0 deg., 5.0 deg.*
Peak Phase Error	On*, Off	(deg)	On*, Off		±0.0 to 100.0 deg., ±20.0 deg.*
Magnitude Error	On*, Off	(%)	On*, Off		0.0 to 100.0 %, 5.0 %*
RF Power					
TX Power	On*, Off	DBM*,WATT	On*, Off	0 to 20,(Unit: WATT) -80.0 to 43.0, 24.0*(Unit: DBM)	0 to 20(Unit: WATT) -80.0 to 43.0, 36.0*(Unit: DBM)
Carrier Off Power	On*, Off	DBM*,WATT	On*, Off		0 to 20, (Unit: WATT) -80.0 to 43.0, -37.0*(Unit: DBM)
On/Off Ratio	On*, Off	(dB)	On*, Off	0 to 100 dB, 70*	
MAX Power	On*, Off		On, Off		0.0 to 10.0 dB, 1.0 dB*
MIN Power	On*, Off		On, Off	-110.0 dB to 0.0 dB, -1.0 dB*	
Template Pass/Fail					
Template	On*, On&Off				
Time Alignment	On*, Off	On*, Off		-64.00 to 1.00 bit, -64*	-64.00 to 1.00 bit, 1.00*
Call Processing Report & Measure					
RX Level	On*, Off		On*, Off	0*	63*
RX Quality	On*, Off		On*, Off	0 to 7, 7*	0 to 7, 0*
MS Power Level	On, Off		On, Off		
Timing Advance	On*, Off*				
2nd page					
RF Power vs Time(MS-NB)	On*, Off		On*, Off	-110.00 dB to 10.00 dB, (-28.0 us:-110 dB* (-18.0 us:-110 dB* (-10.0 us:-110 dB* (-5.0 us:-110 dB* (-0.0 us:-1.0 dB* (542.8 us:-110 dB* (547.8 us:-110 dB* (552.8 us:-110 dB* (560.8 us:-110 dB* (570.8 us:-110 dB*	-110.00 dB to 10.00 dB -70.0 dB* -30.0 dB* -6.0 dB* 4.0 dB* 1.0 dB* 1.0 dB* 1.0 dB* -6.0 dB* -30.0 dB* -70.0 dB*

- *1 Values in parentheses are fixed units.
- *2 The set judgment upper limit value is considered both the upper and lower limit values. (Judgment is made using the absolute value of an error from the reference value.)
- *3 Template On: A signal waveform is applied to measurement only in a section with a burst.
 Template On&Off: A signal waveform is applied to measurement in both sections with and without a burst. (See the figure below.)

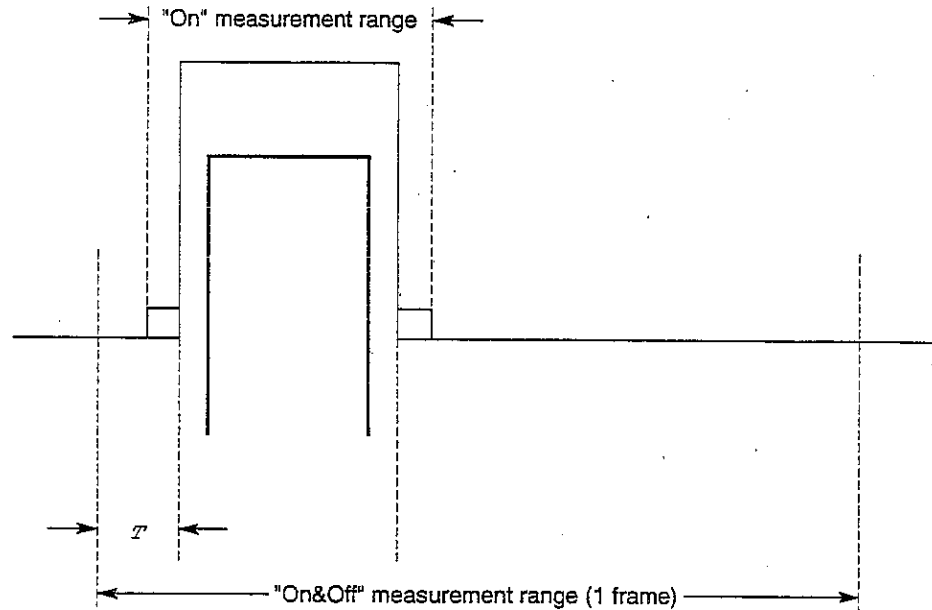

(Cont.)

Item	Measurement On/Off	Unit (Note1)	Judge On/Off	Lower lower limit value	Upper upper limit value
3rd page Output RF Spectrum	On*, Off		On*, Off	-100 to 10 dB (+/-100 kHz: 0.5 dB*) (+/-200 kHz: -30.0 dB*) (+/-250 kHz: -33 dB*) (+/-400 kHz to 2000 kHz : -60 dB*)	-100 to 10 dB -100 to 40 dBm --Switching Transients:dB-- (+/-100 kHz: 0.5 dB*) (+/-200 kHz: -30.0 dB*) (+/-250 kHz: -33 dB*) (+/-400 kHz to 2000 kHz : -60 dB*) --Switching Transients:dBm-- (+/-100 kHz: 30.0 dBm*) (+/-200 kHz: 10.0 dBm*) (+/-250 kHz: 0.0 dBm*) (+/-400 kHz: -17 dBm*) (+/-600 to 1000 kHz: -26 dBm*) (+/-1200 to 1600 kHz: -32 dBm*) (+/-1800 to 2000 kHz: -36 dBm*)

Note: If the unit of the Upper(Switch) is set to dB, the indications of Meas, Judge and Upper(Switch) at 0-kHz Offset Frequency do not appear (non-definable).

- When the [Standard]F10 function key is pressed, items in the all measurement value list (All Measure screen) are set to the initial values.

• Function keys

Main function key:	None
Function key:	Measure Item
1st page	
[Next Page] (F8):	Displays the second page.
[Standard] (F10):	Sets the standard value.
[Back Screen] (F12):	Displays the previous screen.
2nd page	
[Previous Page] (F7):	Displays the first page.
[Next Page]F8:	Displays the third page.
[Standard] (F10):	Sets the standard value.
[Back Screen] (F12):	Displays the previous screen.
3rd page	
[Previous Page]F7:	Displays the second page.
[Standard]F10:	Sets the standard value.
[Back Screen]F12:	Displays the previous screen.

(2) Transmitter all item measurement: All Measure screen

Use the parameters set on the Setup Common Parameter screen (see paragraph 4.3.5) and Setup TX Measure Parameter screen (see paragraph 4.3.6, (1), (a)) to measure and display the items (see paragraph 4.3.6, (1), (b)) set on the Select All Measure Item screen.

- Display the All Measure screen according to the following steps:

Step	key operation	Description
1.	[Main Func on off]F6	Sets the Main Func on to display the Main Menu at the bottom of the screen.
2.	[TX&RX Tester]F1	Sets TX&RX Tester mode. The Setup Common Parameter screen appears.
3.	[TX Measure]F1	Displays the first page of the TX Measure menu.
4.	[All Measure]F7	Displays the first page of the All Measure screen.
5.	[Next Page]F8	Displays the second page of the All Measure screen.
6.	[Next Page]F8	Displays the third page of the All Measure screen.
7.	[Next Page]F8	Displays the fourth page of the All Measure screen.

MT8801B 97/07/01 11:49:24 M Measure : Single				All Measure
<< All Measure (GSM) >>				
Storage : Normal				
Call Proc: Communication				
Page (1/4)				
Pass/Fail				
Frequency				Next Page
Carrier Frequency	: 890.199 996 8 MHz			
Carrier Frequency Error	: 0.0 ppm	Pass		Storage *
Modulation				Mode
RMS Phase Error	: 3.38 deg. (rms)	Pass		Calibration *
Peak Phase Error	: 10.91 deg.	Pass		
Magnitude Error	: 0.15 % (rms)	Pass		Adjust Range
RF Power				
TX Power	: 25.57 dBm	Pass		Back Screen
Carrier Off Power	: -47.68 dBm	Pass		
On/Off Ratio	: 73.25 dB	Pass		
MAX Power	: 0.05 dB	Pass		
MIN Power	: -0.10 dB	Pass		
Template		Pass		
Time Alignment	: 0.61 bit	Pass		
Total Judgment				
PASS				
GSM				1
Channel : 1CH Frequency : 890.200000MHz Level : 21dBm				1 2
Channel #		TX Reference # Level	MS Power # Level	Timing # Advance
				Main Func On Off

Fig. 4-9 Example of All Measure screen (First Page)

Note: When all measurement items are Pass, Total Judgment becomes "PASS." If any one item is Fail, Total Judgment becomes "FAIL."

SECTION 4 OPERATION

The 2nd page of the main function keys on the TX measurement screen (DUT Control: Call Proc)

					1 2
		RX Output # Level	Loop Back On Off		Main Func On Off

The main function keys on the TX measurement screen (DUT Control: None)

					1 2
Channel #	TX Frequency #	TX Reference # Level			Main Func On Off

					1 2
	RX Output # Frequency	RX Output # Level			Main Func On Off

MT8801B 97/07/01 11:50:20 M Measure : Single << All Measure (GSM) >> Storage : Normal Call Proc: Communication Page (2/4) Pass/Fail				All Measure Previous Page Next Page Storage * Mode Calibration * Adjust Range Back -> Screen	
Call Proc report & Measure RX Level : 51 Pass RX Quality : 0 Pass MS Power Level : 8 Pass Timing Advance : 0 Pass					
Total Judgment PASS				GSM[®]	
Channel : 1CH Frequency : 890.200000MHz Level : 21dBm				1 2	
Channel #		TX Reference # Level	MS Power # Level	Timing # Advance	Main Func On Off

Fig. 4-10 Example of All Measure screen (Second Page)

Note: The setup items of Call Proc Report & Measure (RX Level, RX Quality, Timing Advance and Time Alignment) do not appear when the DUT Control is set to None.

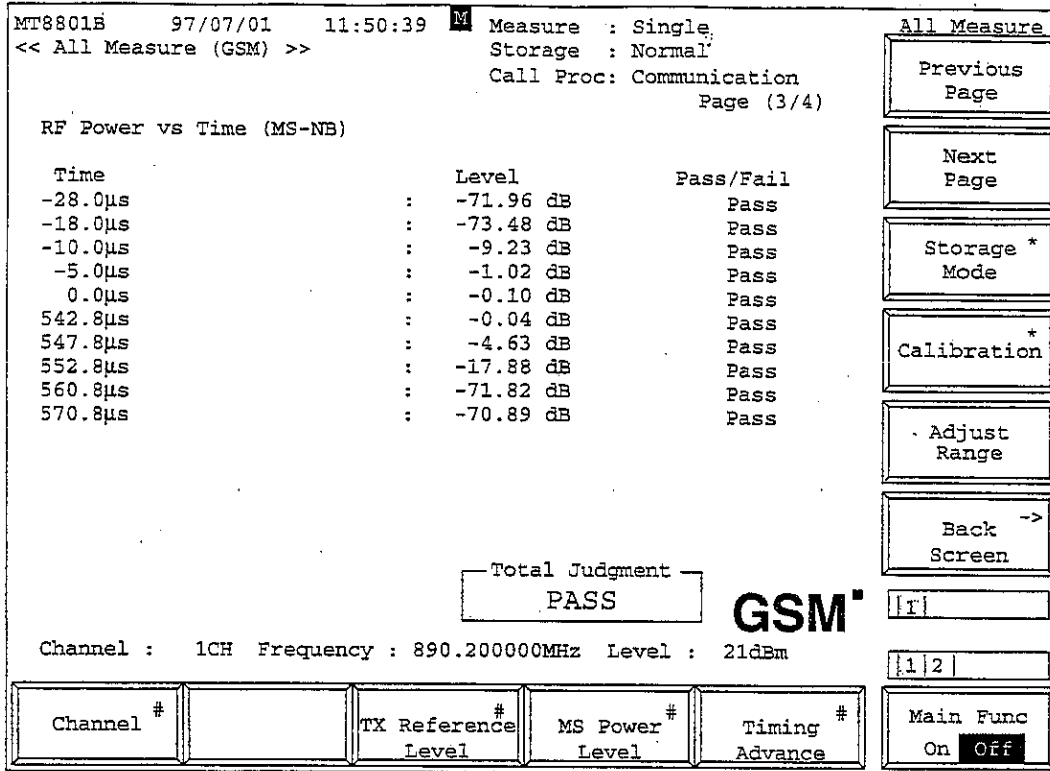

Fig. 4-11 Example of All Measure screen (Third Page)

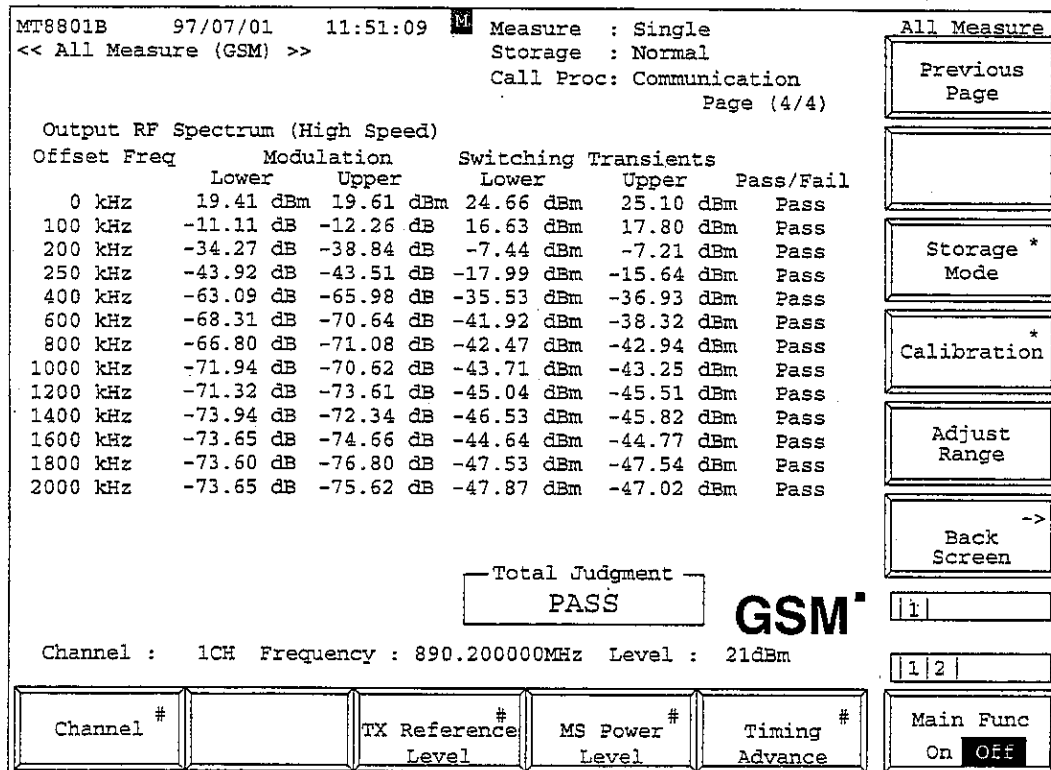

Fig. 4-12 Example of All Measure screen (Fourth Page)

Note: The Pass/Fail result at 0 kHz is displayed when the unit of Switching Transients is set to dBm.

SECTION 4 OPERATION

• Main Function keys

1st page

[Channel]F1

Changes channel number.
When DUT Control is Call Proc, TX Frequency and RX Output Frequency become the values corresponding to the channel number.

[TX Frequency]F2

Changes the transmission frequency of MS(mobile station to be measured) (reception frequency of the MT8801B).
Disappeared when DUT Control is Call Proc, and becomes the value corresponding to the channel number.

[TX Reference Level]F3

Changes the MT8801B reference level to measure the transmission level from MS.

[MS Power Level]F4

Changes the transmission level from MS.
Disappeared when DUT Control is None. (Para. 4.3.5)

[Timing Advance]F5

Changes Time Advance of MS.
Disappeared when DUT Control is None. (Para. 4.3.5)

2nd page

[RX Output Frequency]F2

Changes the reception frequency of MS (output frequency from the MT8801B).
Disappeared when DUT Control is Call Proc, and becomes the value corresponding to the channel number.

[RX Output Level]F3

Changes the reception level of MS (output level from the MT8801B).

[Loop Back On Off]F4

Turns the loop-back state of MS on or off.
Disappeared when DUT Control is None.

• Function keys: All Measure

[Previous Page]F7

Displays the previous page.

[Next Page]F8

Displays the next page.

[Storage Mode]F9:

Displays the storage mode setup menu.

[Normal]F7:

Sets normal mode. (Initial value)

[Average]F8:

Sets averaging mode.

Measure mode is set to Single. (No screen is displayed.)

[Average Count]F9:

Sets an averaging count.

2 to 9999 (Initial value: 10)

[Refresh Interval]F10:

Sets the update time of the averaged-measurement data display.

Every: after every single measurement

Once: after the specified-count-measurement averaging processing

[return]F12:

Returns to the previous menu.

[Calibration]F10:

Displays the level calibration menu.

[Manual Calibration]F7:

Performs level calibration.

During calibration, the window indicating calibration in progress is displayed on the screen.

[Calibration Cancel]F8:

Deletes level calibration data.

[return]F12:

Returns to the previous menu.

[Adjust Range]F11:

Sets the measurement level ranges (RF power meter range and reference level) to the status appropriate for measurement signal.(See paragraph 4.3.1(2))

[Back Screen]F12:

Displays the previous screen.

- (3) Modulation analysis: Modulation Analysis screen (value display) Constellation screen, Eye Diagram screen, Phase Error screen, Magnitude Error screen (waveform display: 4 screens)

Use the parameters set on the Setup Common Parameter screen (see paragraph 4.3.5) and Setup TX Measure Parameter screen (see paragraph 4.3.6, (1), (a)) to analyze a modulated signal from the transmitter, and display a measured value or waveform.

There is one value-display screen. A waveform display screen can be used to select and display one of five measured waveforms (Constellation, Eye Diagram, Vector Error, Phase Error, or Magnitude Error).

- (a) Modulation analysis (value display): Modulation Analysis screen

- Display the Modulation Analysis screen according to the following steps:

Step	key operation	Description
1.	[Main Func on off]F6	Sets the Main Func on to display the Main Menu at the bottom of the screen.
2.	[TX&RX Tester]F1	Sets TX&TR Tester mode. The Setup Common Parameter screen appears.
3.	[TX Measure]F1	Displays the first page of the TX Measure menu.
4.	[Modulation Analysis]F8	Displays the Modulation Analysis screen.

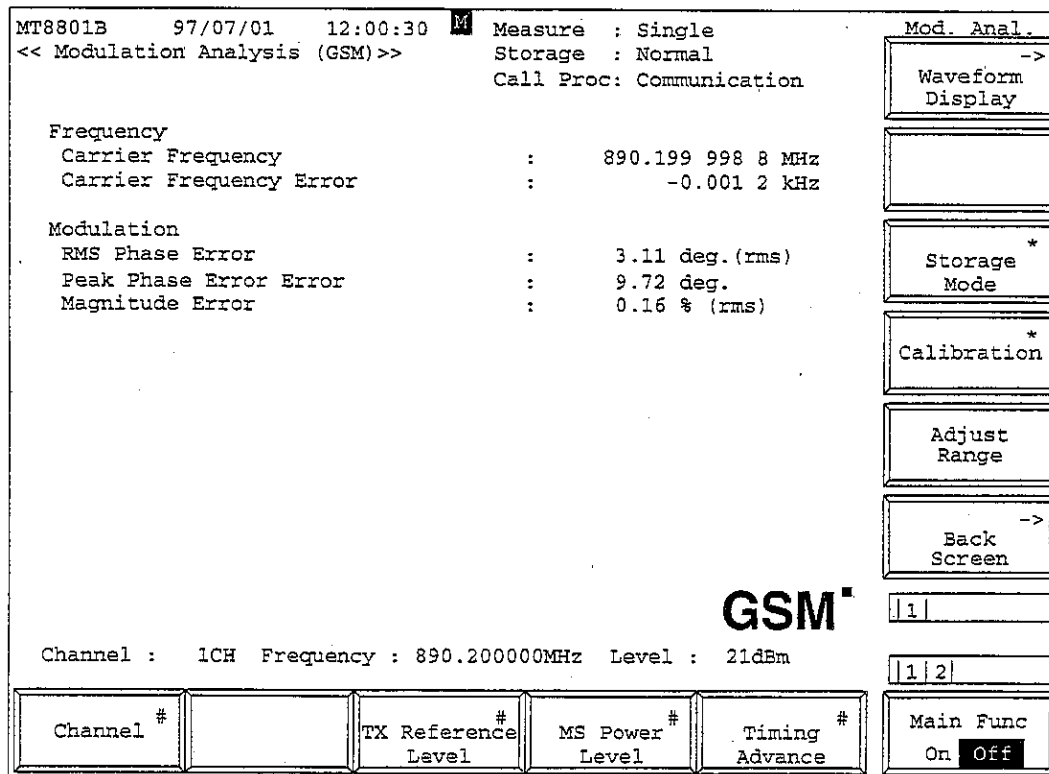
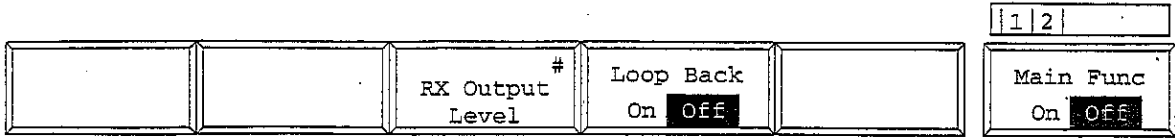
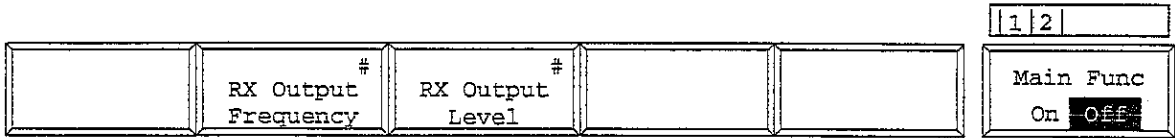
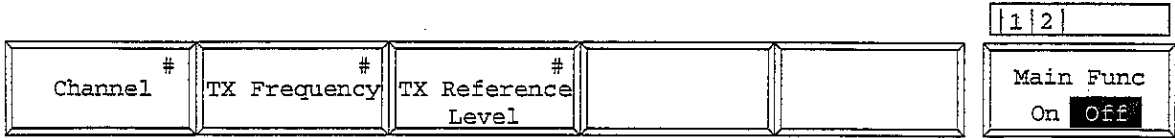

Fig. 4-13 Modulation Analysis Screen

The 2nd page of the main function keys on the TX measurement screen (DUT Control: Call Proc)



The main function keys on the TX measurement screen (DUT Control: None)



- Main Function keys
 - 1st page
 - [Channel]F1
Changes channel number.
When DUT Control is Call Proc, TX Frequency and RX Output Frequency become the values corresponding to the channel number.
 - [TX Frequency]F2
Changes the transmission frequency of MS(mobile station to be measured) (reception frequency of the MT8801B).
Disappeared when DUT Control is Call Proc, and becomes the value corresponding to the channel number.
 - [TX Reference Level]F3
Changes the MT8801B reference level to measure the transmission level from MS.
 - [MS Power Level]F4
Changes the transmission level from MS.
Disappeared when DUT Control is None. (Para. 4.3.5)
 - [Timing Advance]F5
Changes Time Advance of MS.
Disappeared when DUT Control is None. (Para. 4.3.5)
 - 2nd page
 - [RX Output Frequency]F2
Changes the reception frequency of MS (output frequency from the MT8801B).
Disappeared when DUT Control is Call Proc, and becomes the value corresponding to the channel number.
 - [RX Output Level]F3
Changes the reception level of MS (output level from the MT8801B).
 - [Loop Back On Off]F4
Turns the loop-back state of MS on or off.
Disappeared when DUT Control is None.
- Function keys:
 - [Waveform Display]F7:
Displays the Waveform Display screen.
(See paragraph 4.3.6, (3), (b).)
 - [Storage Mode]F9:
Displays the storage mode setup menu.
 - [Normal]F7:
Sets normal mode (initial value).
 - [Average]F8:
Sets averaging mode.
Measure mode is set to Single.
 - [Average Count]F9:
Sets an averaging count.
2 to 9999 (Initial value: 10)
 - [Refresh Interval]F10:
Sets the update time of the averaged-measurement data display.
Every: after every single measurement
Once: after the specified-count-measurement averaging processing
 - [return]F12:
Returns to the previous menu.
 - [Calibration]F10:
Displays the level calibration menu.
 - [Manual Calibration]F7:
Performs level calibration.
During calibration, the window indicating calibration in progress is displayed on the screen.
 - [Calibration Cancel]F8:
Deletes level calibration data.
 - [return]F12:
Returns to the previous menu.
 - [Adjust Range]F11:
Sets the measurement level ranges (RF power meter range and reference level) to the status appropriate for measurement signal. (See paragraph 4.3.1(2))
 - [Back Screen]F12:
Displays the previous screen.

(b) Modulation analysis (waveform display): Constellation screen, Eye Diagram screen, Phase Error screen, Magnitude Error screen

- Display the following four Waveform Display screens according to the steps described below:

Constellation: I to Q constellation
 Eye Diagram: Symbol to I and Symbol to Q eye patterns
 Phase Error: Symbol to phase error
 Magnitude Error: Symbol to magnitude error

Step	key operation	Description
1.	[Main Func on off]F6	Sets the Main Func on to display the Main Menu at the bottom of the screen.
2.	[TX&RX Tester]F1	Sets TX&RX Tester mode. The Setup common Parameter screen appears.
3.	[TX Measure]F1	Displays the first page of the TX Measure menu.
4.	[Modulation Analysis]F8	Displays the Modulation Analysis screen.
5.	[Waveform Display]F7	Displays the Waveform Display screen (initial value: Constellation).
6.	[Constellation] F7	Displays the Constellation screen.
	[Eye Diagram] F8	Displays the Eye Diagram screen.
	[Phase Error] F10	Displays the Phase Error screen.
	[Magnitude Error]F11	Displays the Magnitude Error screen.

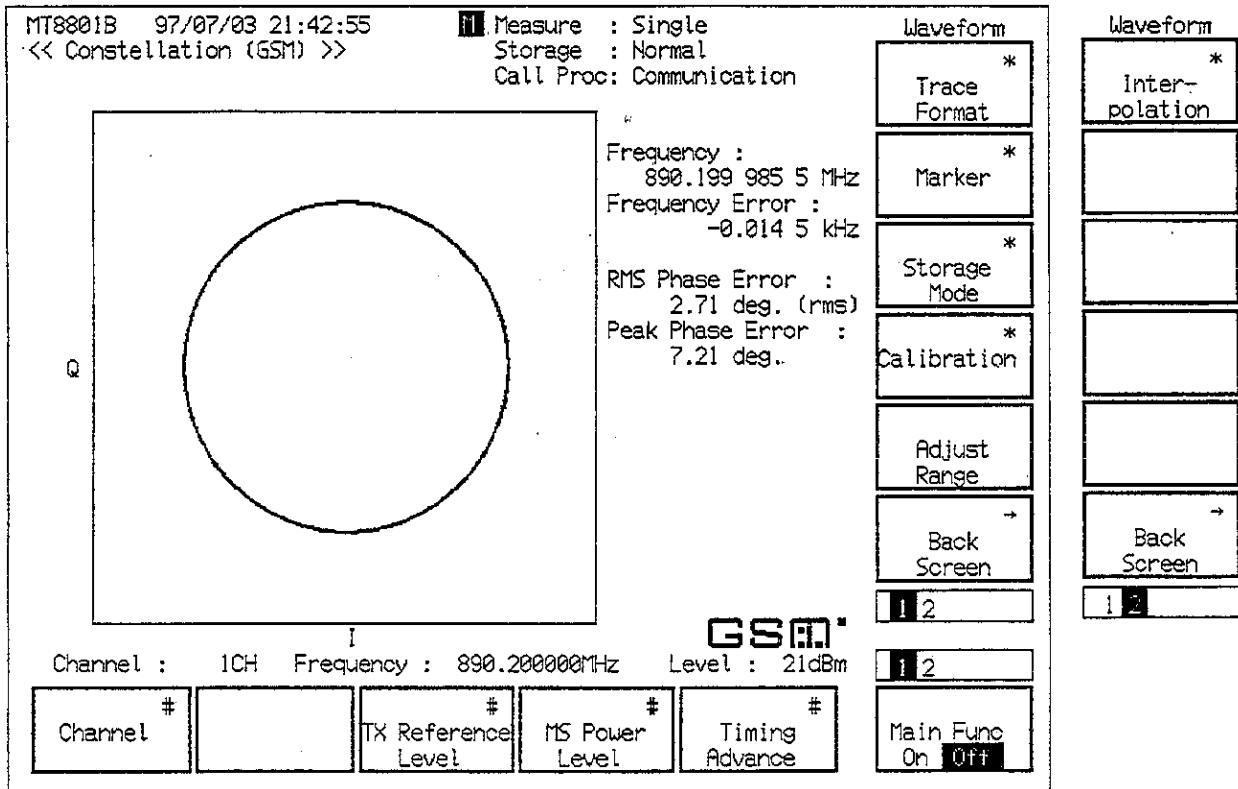
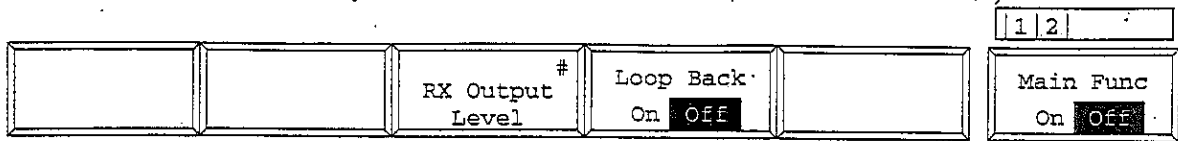

Fig. 4-14 Constellation Screen

The 2nd page of the main function keys on the TX measurement screen (DUT Control: Call Proc)



The main function keys on the TX measurement screen (DUT Control: None)

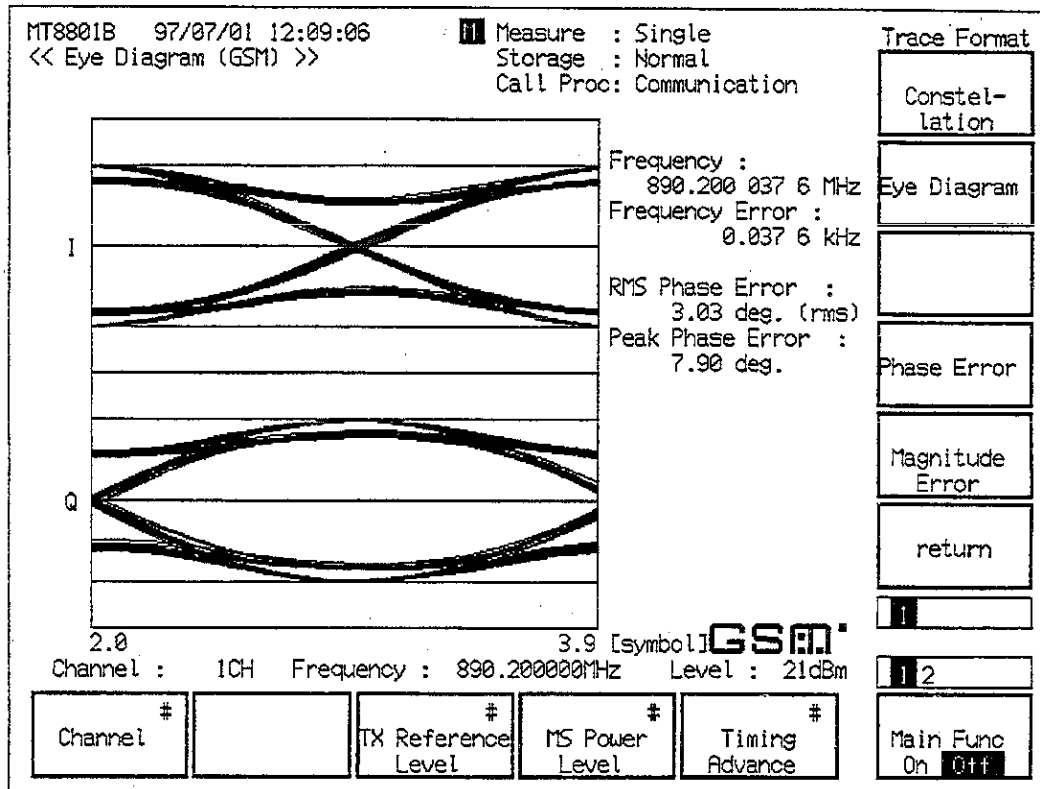
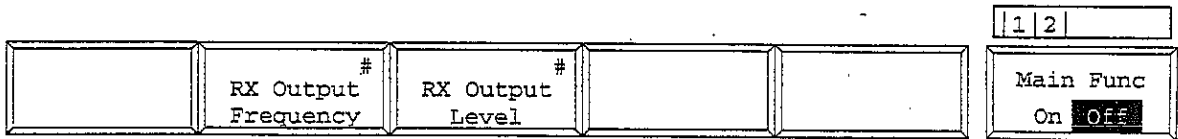
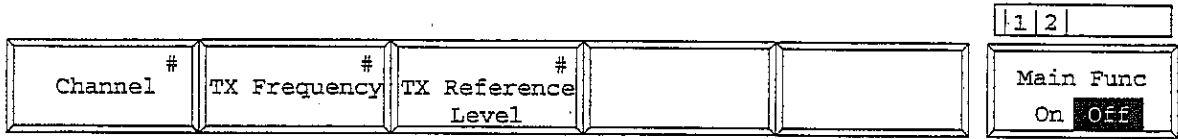

Fig. 4-15 Eye Diagram Screen

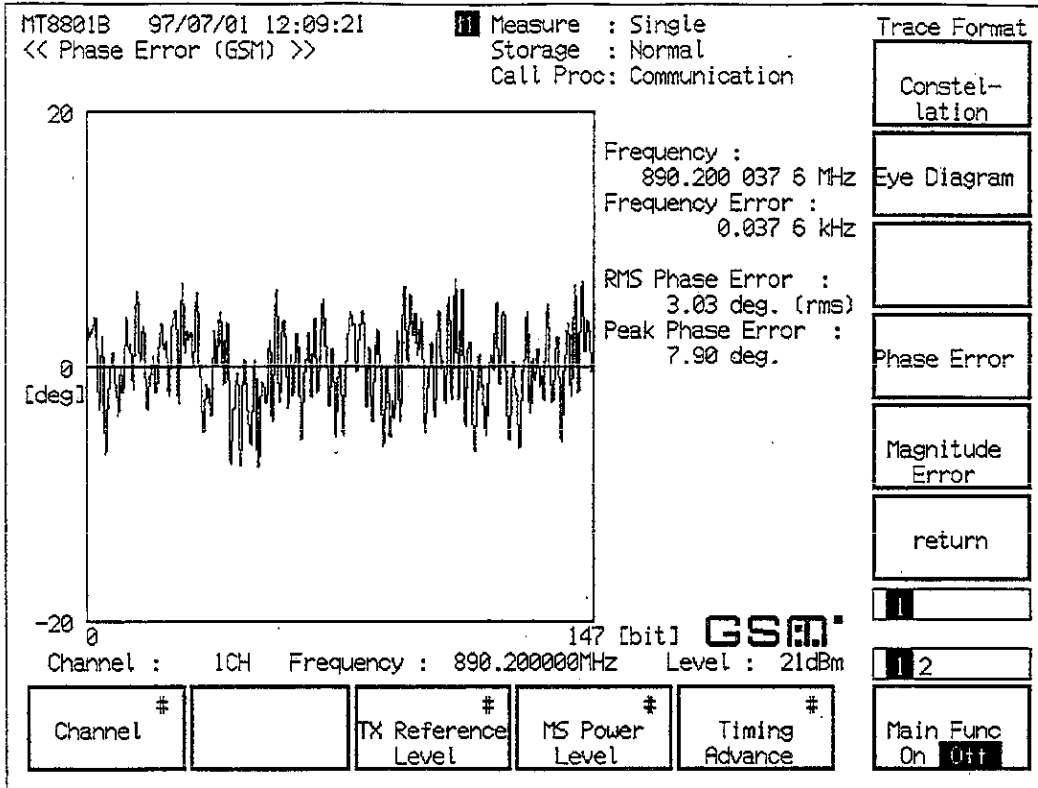

Fig. 4-16 Phase Error Screen

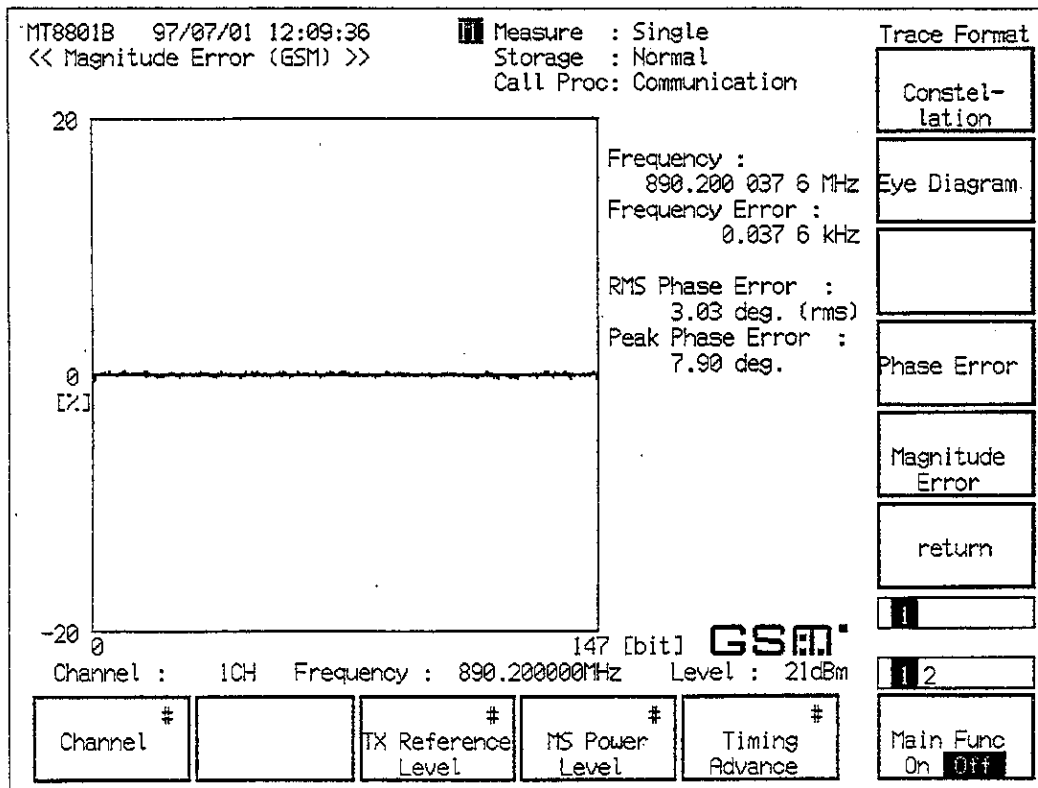

Fig. 4-17 Magnitude Error Screen

- Main Function keys

1st page

[Channel]F1

Changes channel number.

When DUT Control is Call Proc, TX Frequency and RX Output Frequency become the values corresponding to the channel number.

[TX Frequency]F2

Changes the transmission frequency of MS(mobile station to be measured) (reception frequency of the MT8801B).

Disappeared when DUT Control is Call Proc, and becomes the value corresponding to the channel number.

[TX Reference Level]F3

Changes the MT8801B reference level to measure the transmission level from MS.

[MS Power Level]F4

Changes the transmission level from MS.

Disappeared when DUT Control is None. (Para. 4.3.5)

[Timing Advance]F5

Changes Time Advance of MS.

Disappeared when DUT Control is None. (Para. 4.3.5)

2nd page

[RX Output Frequency]F2

Changes the reception frequency of MS (output frequency from the MT8801B).

Disappeared when DUT Control is Call Proc, and becomes the value corresponding to the channel number.

[RX Output Level]F3

Changes the reception level of MS (output level from the MT8801B).

[Loop Back On Off]F4

Turns the loop-back state of MS on or off.

Disappeared when DUT Control is None.

- Function keys:

1st page (common for all waveform screens)

[Trace Format]F7:

Displays the Trace Format menu.

[Constellation]F7:

Displays the Constellation screen (initial value).

[Eye Diagram]F8:

Displays the Eye Diagram screen.

[Phase Error]F10:

Displays the Phase Error screen.

[Magnitude Error]F11:

Displays the Magnitude Error screen.

[return]F12:

Returns to the previous menu.

[Marker]F8:

Displays the Marker menu.

[Normal]F7:

Sets the normal marker mode.

The screen enters the marker-position input wait state.

Resolution:

0.1 symbols (when Interpolation on Constellation display is 10 Points)

1 symbol (under other than the condition above)

[Off]F8:

Sets marker mode off and clears a marker display (initial value).

[return]F12:

Returns to the previous menu.

[Storage Mode]F9:

Displays the storage mode setup menu.

[Normal]F7:

Sets normal mode (initial value).

[Over Write]F8:

Sets overwriting mode.

[return]F12:

Returns to the previous menu.

- [Calibration]F10: Displays the level calibration menu.
- [Manual Calibration]F7: Performs level calibration.
During calibration, the window indicating calibration in progress is displayed on the screen.
- [Calibration Cancel]F8: Deletes level calibration data.
- [return]F12: Returns to the previous menu.
- [Adjust Range]F11: Sets the measurement level range (RF power meter range and reference level) to the status appropriate for measurement signal. (See paragraph 4.3.1 (2))
- [Back Screen]F12: Displays the previous screen.
- 2nd page (when a Constellation screen is displayed)
- [Interpolation]F7: Displays the interpolation mode menu.
- [Non]F7: Sets interpolation mode to no (initial value).
(Symbol points are displayed with dots.)
- [Linear]F8: Sets interpolation mode to linear interpolation.
(Symbol points are connected by a straight line.)
- [10 Points]F9: Sets interpolation mode to 10-point interpolation.
(Symbol points are connected with interpolation of ten divisions.)
- [return]F12: Returns to the previous menu.
- [Back Screen]F12: Displays the previous screen.
- 2nd page (when a Phase Error or Magnitude Error screen is displayed)
- [Vertical Scale]F7: Displays the vertical scale menu.
- (Magnitude Error)
- [5%]F7: Displays the 5% scale.
- [10%]F8: Displays the 10% scale.
- [20%]F9: Displays the 20% scale.
- [50%]F10: Displays the 50% scale.
- [100%]F11: Displays the 100% scale.
- [return]F12: Returns to the previous menu.
- (Phase Error)
- [5deg.]F7: Displays the 5-degree scale.
- [10deg.]F8: Displays the 10-degree scale.
- [20deg.]F9: Displays the 20-degree scale.
- [50deg.]F10: Displays the 50-degree scale.
- [100deg.]F11: Displays the 100-degree scale.
- [return]F12: Returns to the previous menu.
- [Back Screen]F12: Displays the previous screen.
- 2nd page (when an Eye Diagram screen is displayed): No function key is displayed.

(4) RF power (burst magnitude) measurement: RF Power screen, Setup Template screen

Use the parameters set on the Setup Common Parameter screen (see paragraph 4.3.5) and Setup TX Measure Parameter screen (see paragraph 4.3.6, (1), (a)) to measure the RF power of the send signal from the transmitter.

For the burst signal measurement, the template (magnitude standard line) of the RF power waveform can be set (on Setup Template screen).

Note that a template can be displayed only when a relative level mode is set at burst signal measurement.

Note: On the RF Power screen, the power sensor is not used; the internal IF level is used to measure the power.

(a) Measuring the power: RF Power screen

- Display the RF Power screens according to the following steps:

Step	key operation	Description
1.	[Main Func on off]F6	Sets the Main Func on to display the Main Menu at the bottom of the screen.
2.	[TX&RX Tester]F1	Sets TX&RX Tester mode. The Setup Common Parameter screen appears.
3.	[TX Measure]F1	Displays the first page of the TX Measure menu.
4.	[RF Power]F9	Displays the RF Power screen. The first page of the RF Power menu appears.

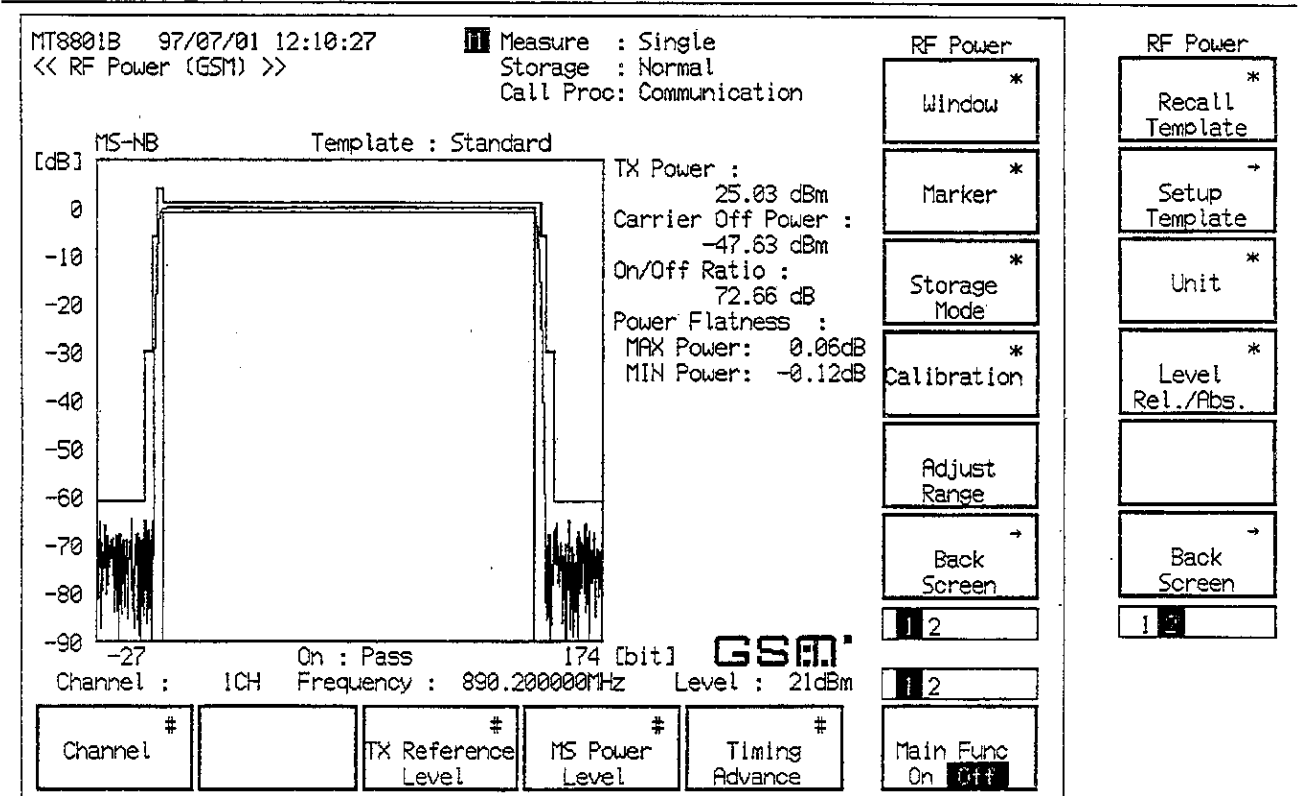
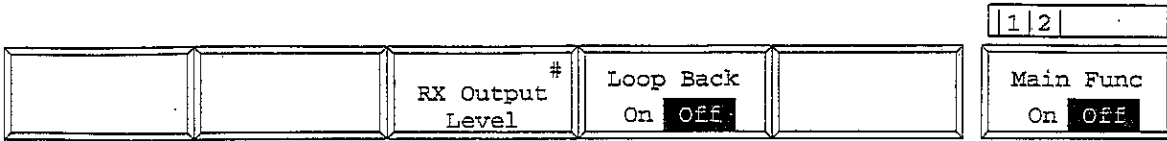

Fig. 4-18 RF Power Screen

The 2nd page of the main function keys on the TX measurement screen (DUT Control: Call Proc)



The main function keys on the TX measurement screen (DUT Control: None)

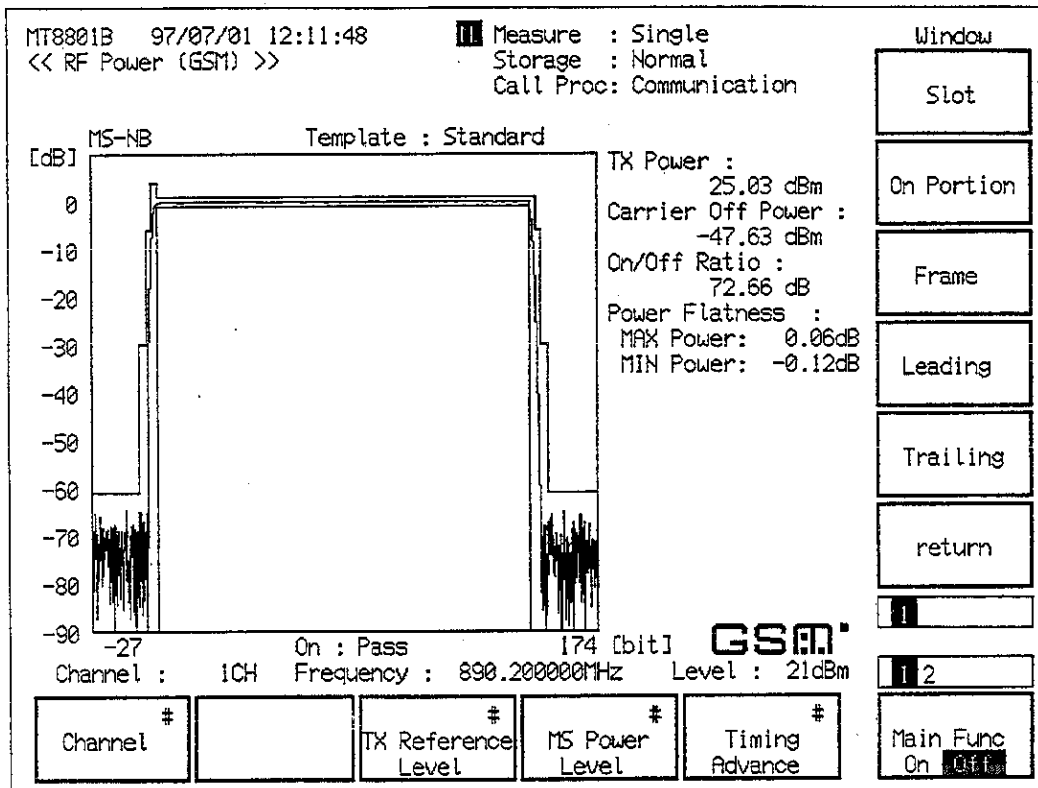
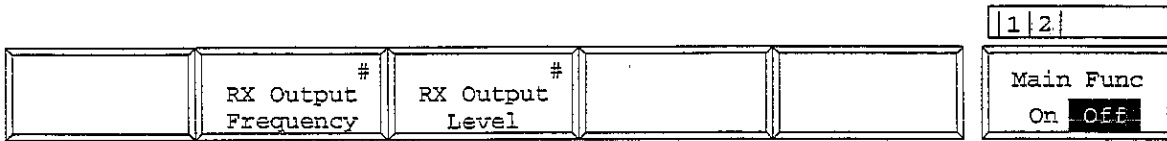
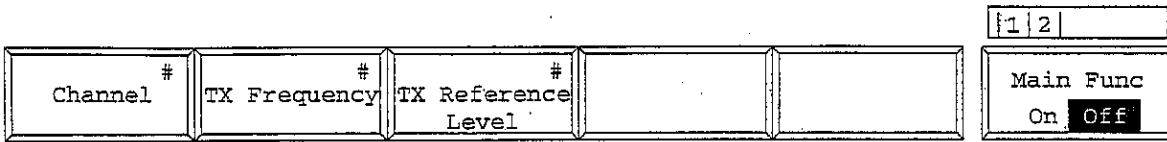

Fig. 4-19 RF Power Screen (Slot Window)

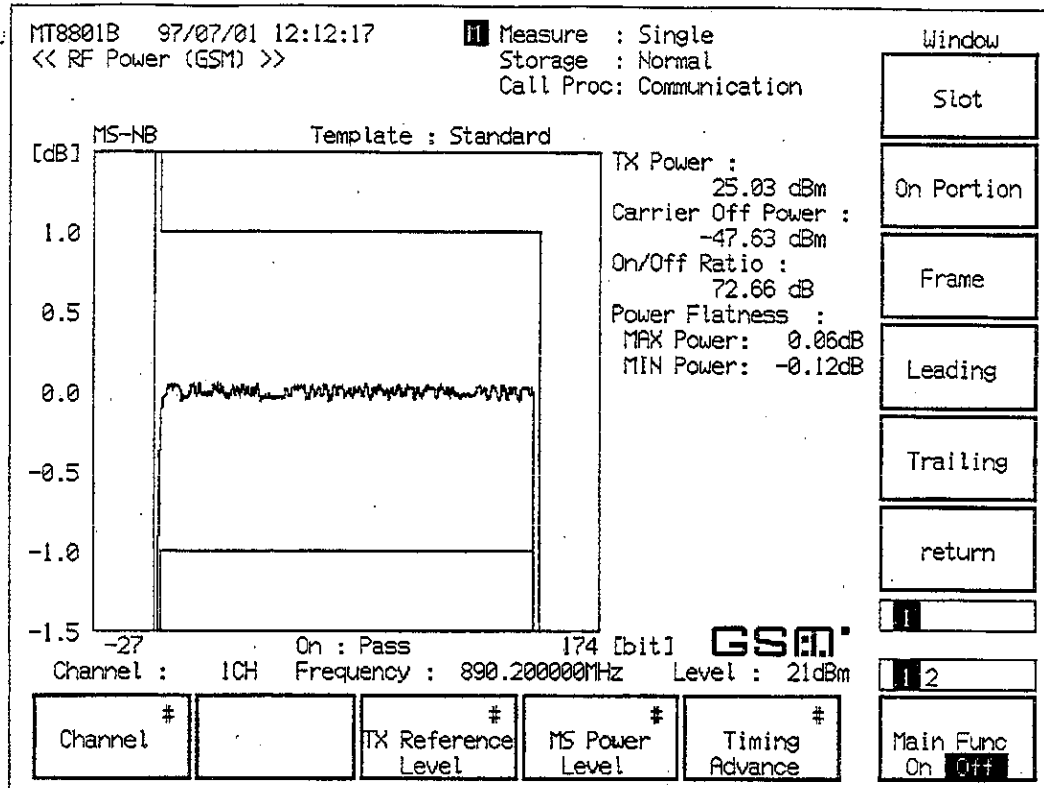

Fig. 4-20 RF Power Screen (On-Portion Window)

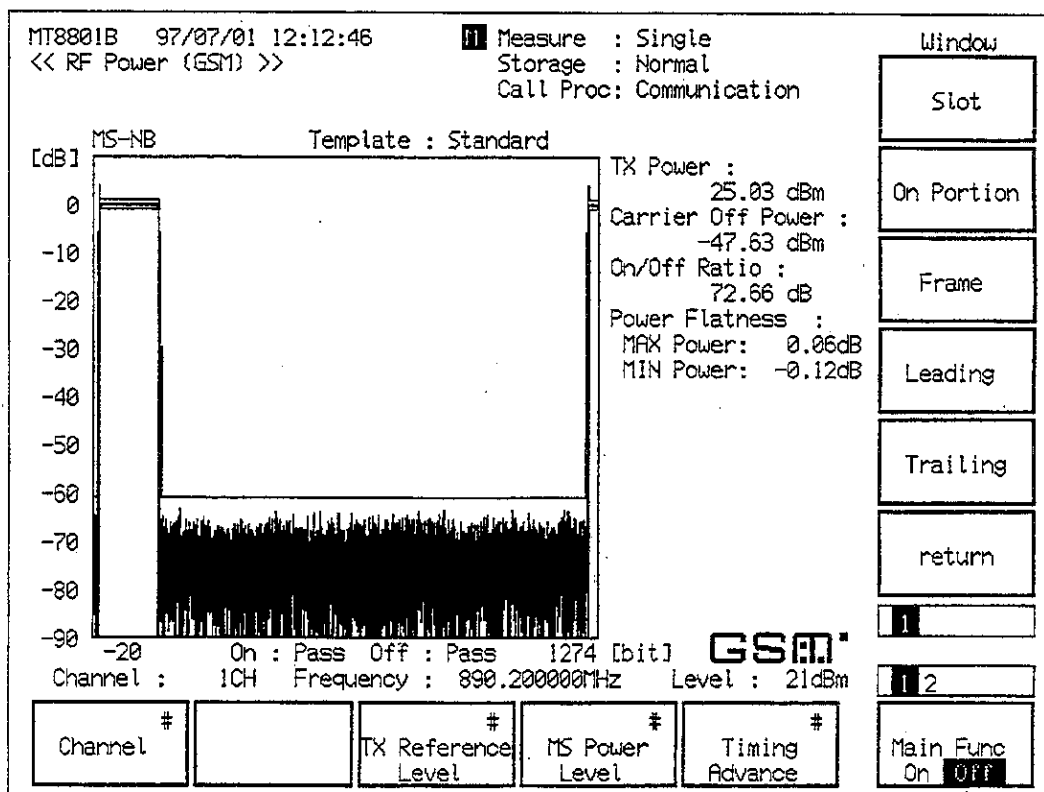

Fig. 4-21 RF Power Screen (Frame Window)

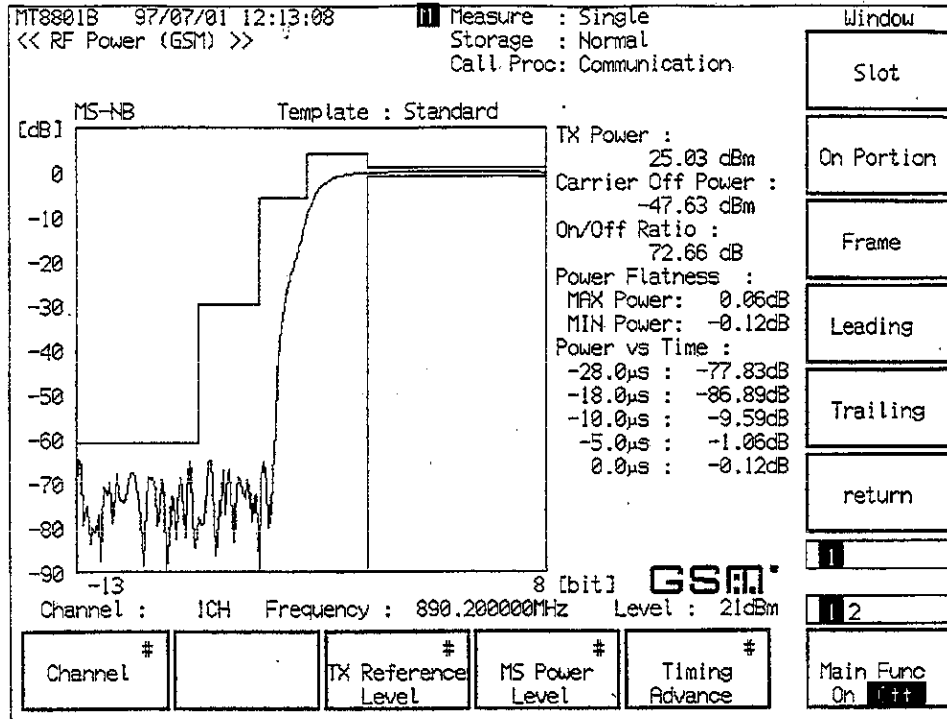

Fig. 4-22 RF Power Screen (Leading Window)

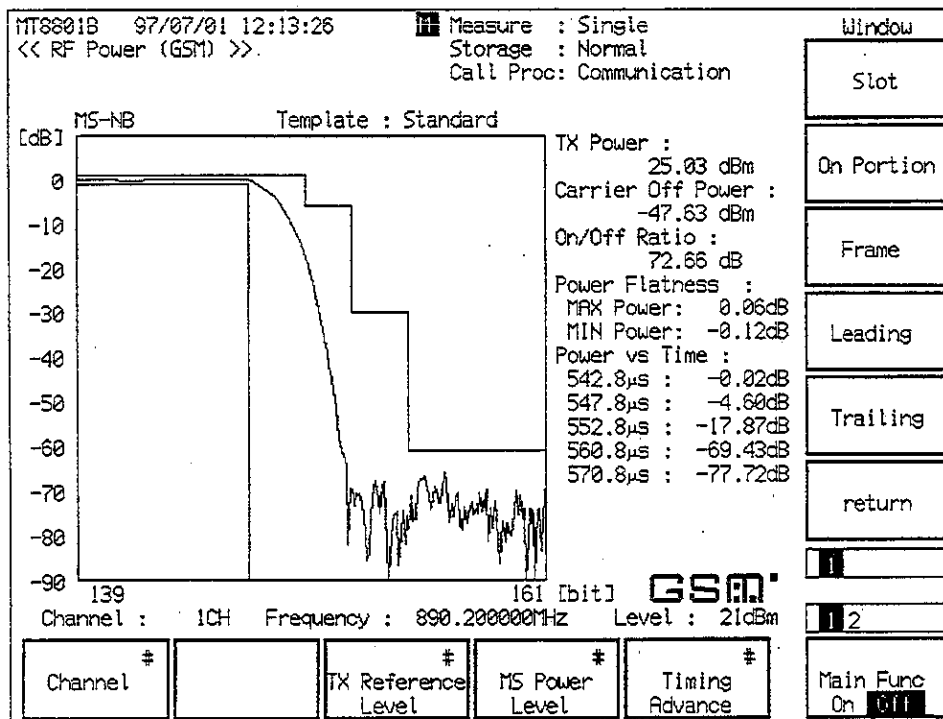

Fig. 4-23 RF Power Screen (Trailing Window)

- Notes:
- When measuring the burst signal while the relative level of the magnitude measurement waveform is displayed, a template (magnitude standard line) can also be displayed.
 - TX Power: Displays the average power in the burst .
 - Carrier Off Power: Displays an average power when transmission is not performed. Carrier Off Power is displayed when the burst signal is measured.

- Main Function keys

1st page

[Channel]F1

Changes channel number.

When DUT Control is Call Proc, TX Frequency and RX Output Frequency become the values corresponding to the channel number.

[TX Frequency]F2

Changes the transmission frequency of MS (mobile station to be measured) (reception frequency of the MT8801B).

Disappeared when DUT Control is Call Proc, and becomes the value corresponding to the channel number.

[TX Reference Level]F3

Changes the MT8801B reference level to measure the transmission level from MS.

[MS Power Level]F4

Changes the transmission level from MS.

Disappeared when DUT Control is None. (Para. 4.3.5)

[Timing Advance]F5

Changes Time Advance of MS.

Disappeared when DUT Control is None. (Para. 4.3.5)

2nd page

[RX Output Frequency]F2

Changes the reception frequency of MS (output frequency from the MT8801B).

Disappeared when DUT Control is Call Proc, and becomes the value corresponding to the channel number.

[RX Output Level]F3

Changes the reception level of MS (output level from the MT8801B).

[Loop Back On Off]F4

Turns the loop-back state of MS on or off.

Disappeared when DUT Control is None.

- Function keys:

1st page

[Window]F7:

Displays a waveform-window setup menu.

[Slot]F7:

Displays a waveform corresponding to one slot.

[On Portion]F8:

Displays a expanded waveform at the burst-on portion.

[Frame]F9:

Displays a waveform corresponding to one frame.

[Leading]F10:

Displays a waveform at the leading edge of the burst signal.

[Trailing]F11:

Displays a waveform at the trailing edge of the burst signal.

[return]F12:

Returns to the previous menu.

[Marker]F8:

Displays the Marker menu.

If this key is pressed when Off is selected, Normal is selected.

[Normal]F7:

Sets normal marker mode. Enters the marker-position input wait status.

Range: Lower limit to upper limit of horizontal display scale
(unit: symbol)

Resolution: 0.1 symbol

Initial value: Center of the screen

[Off]F8:

Sets marker mode to off and clear the marker (initial value).

[return]F12:

Returns to the previous menu.

[Storage Mode]F9:	Displays the storage mode setup menu. Either of the following items can be selected:
1st page	
[Normal]F7:	Displays the normal waveform storage mode setup menu.
[Average]F8:	Sets averaging mode. Measure mode is set to Single.
[Average Count]F9:	Sets the averaging count. 2 to 9,999, Resolution: 1, Initial value: 10
[Refresh Interval]F10:	Sets the update time of the averaged-measurement data display. Every: after every single measurement Once: after the specified-count-measurement averaging processing
[Wide Dynamic Range]F11:	Increases the vertical axis display range by 20 dB to make it 120 dB. Measure mode is set to Single. This item can be selected when RF Input is set to MAIN on the Instrument Setup screen and the measurement signal is a burst signal with a synchronous word.
[return]F12:	Returns to the previous menu.
The 2nd page	
[Max Hold]F7:	Compares new and old waveform data items each time a measurement is performed, and displays the larger data item. (Maximum value holding)
[Min Hold]F8:	Compares new and old data items each time a measurement is performed, and displays the smaller data item. (Minimum value holding)
[Cumulative]F9:	Sets waveform dot data accumulation display mode.
[Over Write]F10:	Sets the waveform overwriting mode.
[return]F12:	Returns to the previous menu.
[Calibration]F10:	Displays the level calibration menu.
[Manual Calibration]F7:	Performs level calibration. During calibration, the window indicating calibration in progress is displayed on the screen.
[Calibration Cancel]F8:	Deletes level calibration data.
[return]F12:	Returns to the previous menu.
[Adjust Range]F11:	Sets the measurement level ranges (RF power meter range and reference level) to the status appropriate for measurement signals. (See paragraph 4.3.1 (2))
[Back Screen] (F12):	Displays the previous screen.

2nd page

[Recall Template]F7:	Displays the template calling menu. (See paragraph 4.3.9)
[Setup Template]F8:	Displays the template setup (Setup Template) screen. (See paragraph 4.3.6, (4), (b).)
[Unit]F9:	Displays the power measurement unit menu.
[dBm]F7:	Sets the power measurement value unit to dBm (initial value)
[nW/ μ W/mW/W]F8:	Switches the power measurement value unit to the watt system.
[return]F12:	Returns to the previous menu.
[Level Rel./Abs.]F10:	Displays the menu for selecting absolute or relative display of the waveform vertical axis scale.
[Relative]F7:	Sets the waveform vertical axis scale to relative display (dB). This function key displays a relative value from the average power at burst-on (initial value).
[Absolute]F8:	Sets the waveform vertical scale to absolute display (dBm). No template is displayed.
[return]F12:	Returns to the previous menu.
[Back Screen]F12:	Displays the previous screen.

(b) Setting the template: Setup Template screen

- Display the Setup Template according to the following steps:

Step	key operation	Description
1.	[Main Func on off]F6	Sets the Main Func on to display the Main Menu at the bottom of the screen.
2.	[TX&RX Tester]F1	Sets TX&RX Tester mode. The Setup Common Parameter screen appears.
3.	[TX Measure]F1	Displays the first page of the TX Measure menu.
4.	[RF Power]F9	Displays the RF Power screen. The first page of the RF Power menu appears.
5.	Next Menu [▲]	Displays the second page of the RF Power menu.
6.	[Setup Template]F8	Displays the Setup Template screen.

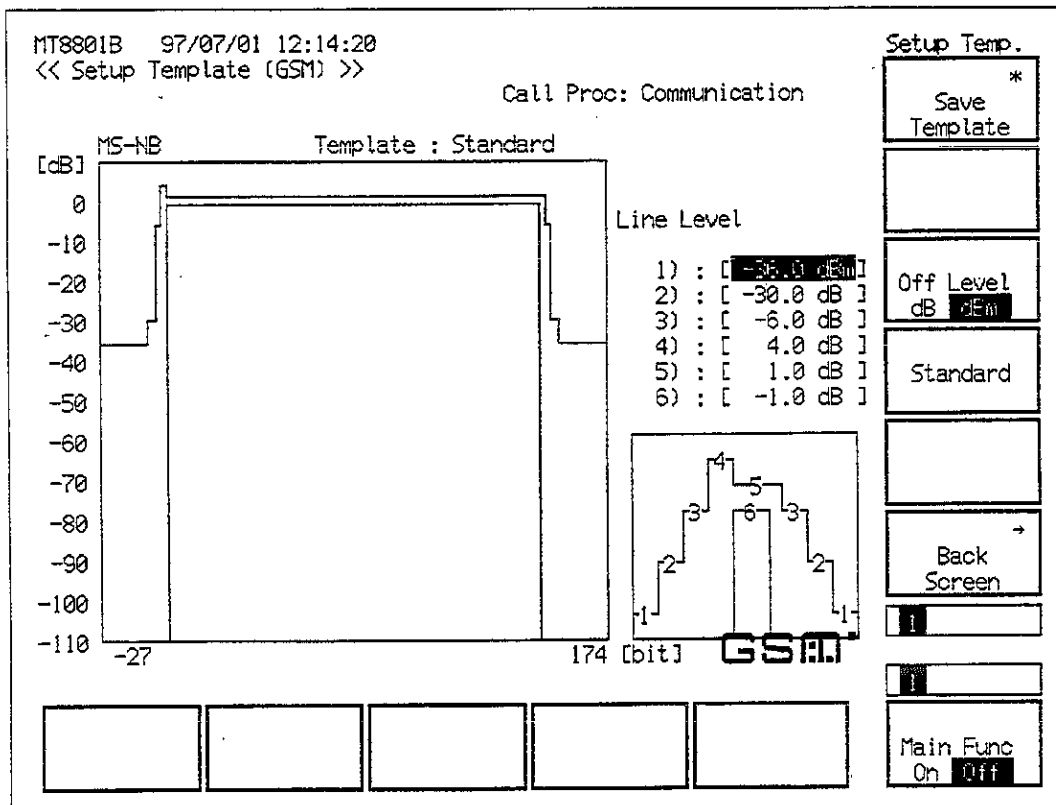

Fig. 4-24 Setup Template Screen (Standard)

Note: When the template to be called is modified, the template name becomes "Not Selected" indicating that the template is not saved in internal memory.

- Set the following items on the Setup Template screen.

Item	Range	Resolution	Initial value
Line Level			
1	-110.0 to 10.0 dB/dBm	0.1 dB	standard value
2	-110.0 to 10.0 dB	0.1 dB	standard value
3	-110.0 to 10.0 dB	0.1 dB	standard value
4	-110.0 to 10.0 dB	0.1 dB	standard value
5	-110.0 to 10.0 dB	0.1 dB	standard value
6	-110.0 to 10.0 dB	0.1 dB	standard value

- Function keys

Main function key:

None.

Function keys:

[Save Template]F7:

Displays the template calling menu. (See paragraph 4.3.9)

[Off Level dB dBm]F9:

Selects a template level-1 unit (dB or dBm). (Initial value: dB)

[Standard]F10:

Sets the standard template.

[Back Screen]F12:

Displays the previous screen.

(5) Output RF spectrum measurement: Output RF Spectrum screen

Use the parameters set on the Setup Common Parameter screen (see paragraph 4.3.5) and Setup TX Measure Parameter screen (see paragraph 4.3.4, (1), (a)) to measure the spectrum at the upper and lower offset frequencies of a send signal from the transmitter.

- Display the Output RF Spectrum screen according to the following steps:

Step	key operation	Description
1.	[Main Func on off]F6	Sets the Main Func on to display the Main Menu at the bottom of the screen.
2.	[TX&RX Tester]F1	Sets TX&RX Tester mode. The Setup Common Parameter screen appears.
3.	[TX Measure]F1	Displays the first page of the TX Measure menu.
4.	[Output RF Spectrum]F10	Displays the Output RF Spectrum screen.

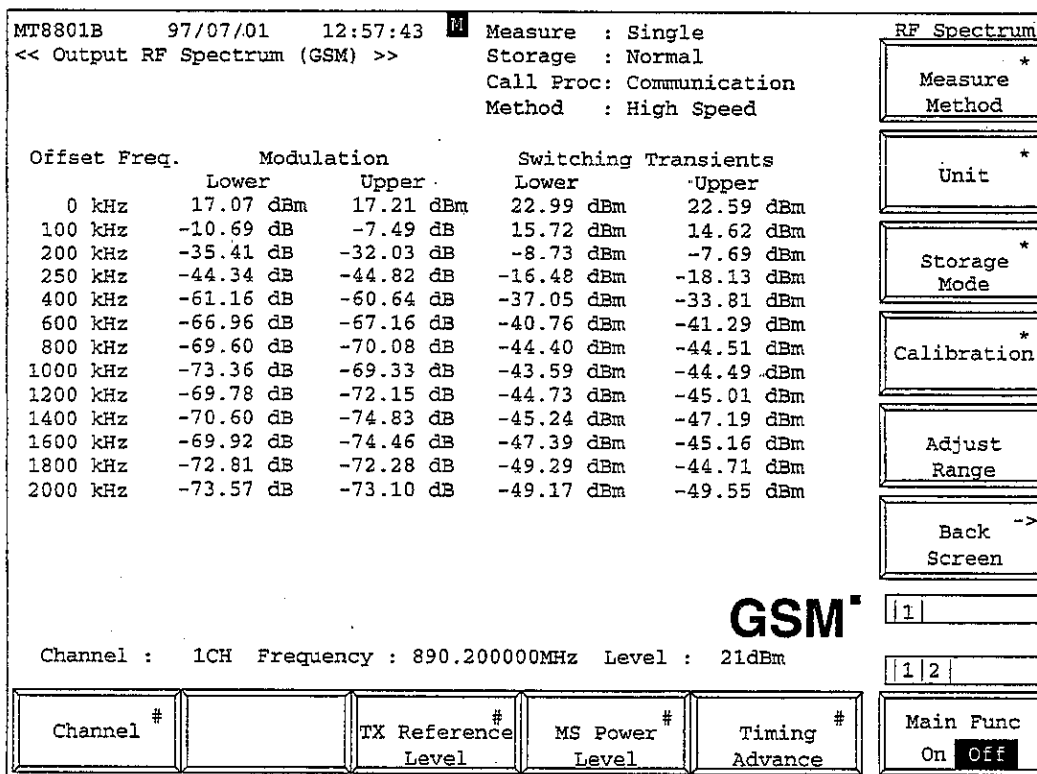

Fig. 4-25 Output RF Spectrum Screen

The 2nd page of the main function keys on the TX measurement screen (DUT Control: Call Proc)

		RX Output # Level	Loop Back On Off		1 2
					Main Func On Off

The main function keys on the TX measurement screen (DUT Control: None)

					1 2
Channel #	TX Frequency #	TX Reference # Level			Main Func On Off

					1 2
	RX Output # Frequency	RX Output # Level			Main Func On Off

Note: The Switching Transient is displayed in the unit (dBm/dB) set on the Select All Measure Item screen.

- Main Function keys

1st page

[Channel]F1

Changes channel number.

When DUT Control is Call Proc, TX Frequency and RX Output Frequency become the values corresponding to the channel number.

[TX Frequency]F2

Changes the transmission frequency of MS(mobile station to be measured) (reception frequency of the MT8801B).

Disappeared when DUT Control is Call Proc, and becomes the value corresponding to the channel number.

[TX Reference Level]F3

Changes the MT8801B reference level to measure the transmission level from MS.

[MS Power Level]F4

Changes the transmission level from MS.

Disappeared when DUT Control is None. (Para. 4.3.5)

[Timing Advance]F5

Changes Time Advance of MS.

Disappeared when DUT Control is None. (Para. 4.3.5)

2nd page

[RX Output Frequency]F2

Changes the reception frequency of MS (output frequency from the MT8801B).

Disappeared when DUT Control is Call Proc, and becomes the value corresponding to the channel number.

[RX Output Level]F3

Changes the reception level of MS (output level from the MT8801B).

[Loop Back On Off]F4

Turns the loop-back state of MS on or off.

Disappeared when DUT Control is None.

- Function keys:
 - [Measure Method]F7: Displays the measure method setup menu.
 - [High Speed]F9: Sets High Speed method.
 - [return]F12: Returns to previous menu.
 - [Unit]F8: Displays the switching transients measurement value unit menu.
 - [dBm]F7: Sets the switching transients measurement value unit to dBm. (initial value)
 - [dB]F8: Sets the switching transients measurement value unit to dB.
 - [return]F12: Returns to previous menu.
 - [Storage Mode]F9: Displays the storage mode setup menu.
 - [Normal]F7: Sets normal mode (initial value).
 - [Average]F8: Sets averaging mode.
The Measure mode is set to Single.
 - [Average Count]F9: Sets the averaging count.
2 to 9999, Resolution: 1, Initial value: 10
 - [Refresh Interval]F10: Sets the update time of the averaged-measurement data display.
Every: after every single measurement
Once: after the specified-count-measurement averaging processing
 - [return]F12: Returns to the previous menu.
 - [Calibration]F10: Displays the level calibration menu.
 - [Manual Calibration]F7: Performs level calibration.
During calibration, the window indicating that calibration in progress is displayed on the screen.
 - [Calibration Cancel]F8: Deletes the level calibration data.
 - [return]F12: Returns to the previous menu.
 - [Adjust Range]F11: Sets the measurement level range (RF power meter range and reference level) to the status appropriate for measurement signals. (See paragraph 4.3.1 (2))
 - [Back Screen]F12: Displays the previous screen.

(6) RF power (average) measurement: Power Meter screen

Use the power sensor to measure the average power on the Power Meter screen.

- Display the Power Meter screen according to the following steps:

Step	key operation	Description
1.	[Main Func on off]F6	Sets the Main Func on to display the Main Menu at the bottom of the screen.
2.	[TX&RX Tester]F1	Sets TX&RX Test mode. The Setup Common Parameter screen appears.
3.	[TX Measure]F1	Displays the first page of the TX Measure menu.
4.	[Power Meter]F12	Displays the Power Meter screen.

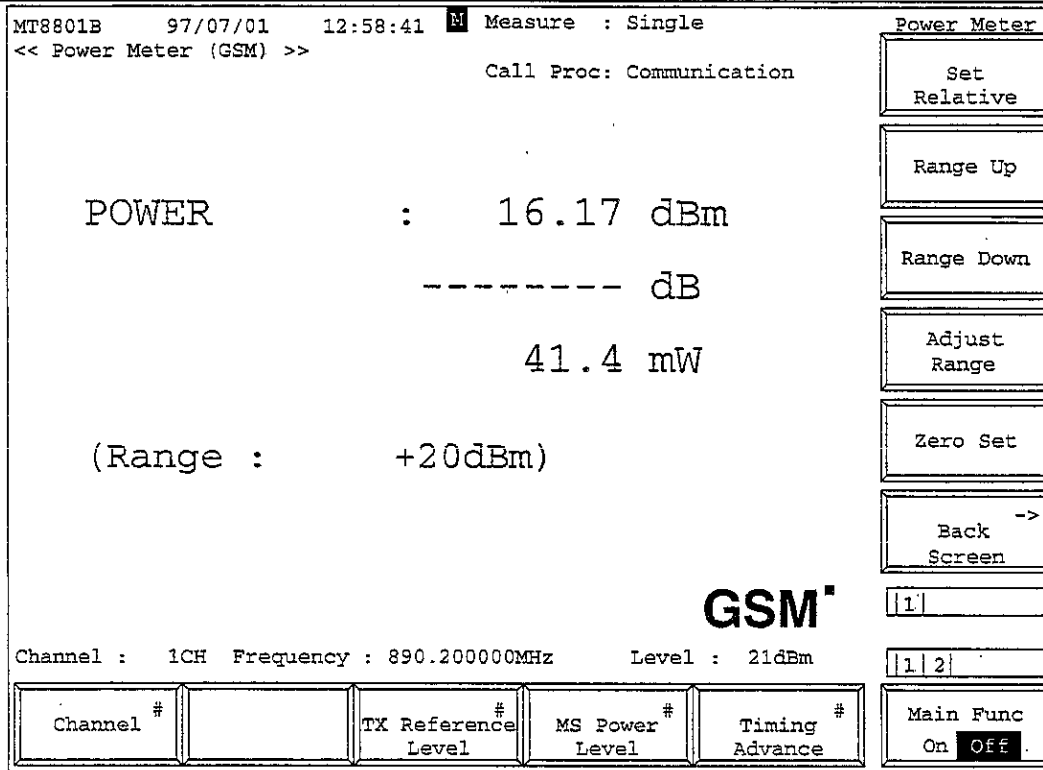
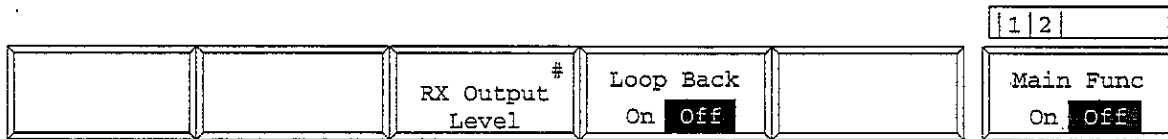
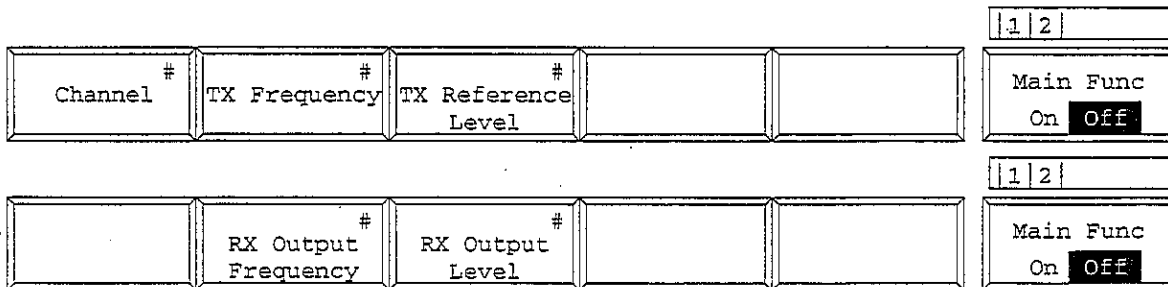

Fig. 4-26 Power Meter Screen

The 2nd page of the main function keys on the TX measurement screen (DUT Control: Call Proc)



The main function keys on the TX measurement screen (DUT Control: None)



Note: The measured results are displayed in units of dBm/dB (relative display)/W in this order.

- Main Function keys

1st page

[Channel]F1

Changes channel number.

When DUT Control is Call Proc, TX Frequency and RX Output Frequency become the values corresponding to the channel number.

[TX Frequency]F2

Changes the transmission frequency of MS(mobile station to be measured) (reception frequency of the MT8801B).

Disappeared when DUT Control is Call Proc, and becomes the value corresponding to the channel number.

[TX Reference Level]F3

Changes the MT8801B reference level to measure the transmission level from MS.

[MS Power Level]F4

Changes the transmission level from MS.

Disappeared when DUT Control is None. (Para. 4.3.5)

[Timing Advance]F5

Changes Time Advance of MS.

Disappeared when DUT Control is None. (Para. 4.3.5)

2nd page

[RX Output Frequency]F2

Changes the reception frequency of MS (output frequency from the MT8801B).

Disappeared when DUT Control is Call Proc, and becomes the value corresponding to the channel number.

[RX Output Level]F3

Changes the reception level of MS (output level from the MT8801B).

[Loop Back On Off]F4

Turns the loop-back state of MS on or off.

Disappeared when DUT Control is None.

- Function keys:

[Set Relative]F7:

Enables to display the power measurement result using a relative value.

The reference value is the power measurement value immediately before setting the relative value display.

If the Power Meter screen is switched to another screen or the power is turned off, the screen enters absolute value display mode and the set reference value is invalid.

[Range Up]F8:

Increases the measurement range.

[Adjust Range]F10:

Sets the measurement level ranges (RF power meter range and reference level) to the status appropriate for measurement signal.

(See paragraph 4.3.1, (2))

[Zero Set]F11:

Adjusts zero-point of the power meter, as described below.

[Back Screen]F12:

Displays the previous screen.

- Power meter zero calibration

To make accurate RF power measurement in transmitter measurement (TX Measure mode), calibrate the zero position of the power meter as described below.

Step	Key operation	Description
1.		Remove any signal input to the RF input connector (Main).
2.	[Main Func on off]F6	Sets the Main Func on to display the Main Menu at the bottom of the screen.
3.	[TX&RX Tester]F1	Sets the TX&RX Tester mode. The Setup Common Parameter screen appears.
4.	[TX Measure]F1	Displays the first page of the TX Measure menu.
5.	[Power Meter]F12	Displays the Power Meter screen.
6.	[Zero Set]F11	Zero-calibrates the power meter. During zero calibration, the window indicating that calibration is being performed is displayed on the screen.
7.	[Back Screen]F12	Returns to the Setup Common Parameter screen.

4.3.7 Receiver test: RX Measure mode

This paragraph describes how to set parameters (Setup RX Measure Parameter) and measure the bit error rate (on Bit Error Rate screen).

(1) Setting parameters: Setup RX Measure Parameter screen

The following describes how to set parameters (Setup RX Measure Parameter screen) when conducting the receiver test (RX Measure mode).

- Display the Setup RX Measure Parameter according to the following steps, then set the RX parameters.

Step	key operation	Description
1.	[Main Func on off]F6	Sets the Main Func on to display the Main Menu at the bottom of the screen.
2.	[TX&RX Tester]F1	Sets TX&RX Tester mode. The Setup Common Parameter screen appears.
3.	[RX Measure]F2	Displays the RX Measure menu.
4.	Next Menu[▲]	Displays the 2nd page of the RX Measure menu.
5.	[Setup RX Parameter]F8	Displays the Setup RX Measure Parameter screen.

MF8801B 97/07/03 21:40:44
 << Setup RX Measure Parameter (GSM) >>
 Call Proc: Stop

Output Signal
 TCH Test Pattern : [PAT1]
 SACCH MS Power Level : [8]

BER

Measure	Judge	Sample	Event Limit
FER / CRC	: [Off]	[500]	[1]
CIb	: [Off]	[66000]	[270]
CII	: [Off]	[39000]	[950]

User Cal Factor
 Band 1 (0.300000MHz to 1499.999999MHz) : [0.0dB]
 Band 2 (1500.000000MHz to 3000.000000MHz) : [0.0dB]

Output Level Correction : [TCH]

GSM

Back ->
Screen

1

1

Main Func
On Off

Fig. 4-27 Setup RX Measure Parameter Screen

```
PAT3 : +-----+-----+-----+---
        FFFFFFFFFFFFFFFFFFFFFFFFFFFFFFFF
        FFFFFFFFFFFFFFFFFFFFFFFFFFFFFFFF
        F
```

```
PAT4 : +-----+-----+-----+---
        4EC3029E7DF836AC53DC1A8D69E820B7
        44CD0E9776F039A55ED4118462E02CBA
        4
```

```
PAT5 : +-----+-----+-----+---
        65E729BC4CC1009C7EFB34AF51DF188E
        6AEB23B547CE0C9574F33AA65CD71287
        6
```

```
PAT6 : +-----+-----+-----+---
        D0178065E729BC4CC1009C7EFB34AF51
        DF188E6AEB23B547CE0C9574F33AA65C
        D
```

```
PAT7 : +-----+-----+-----+---
        A75DD6138661E22EB948C707997AFC30
        AA56DA1F8B6CEC25B043CB089070F43C
        A
```

```
PAT8 : +-----+-----+-----+---
        34AF51DF188E6AEB23B547CE0C9574F3
        3AA65CD7128760E32FB849C606987BFD
        3
```

```
PAT9 : +-----+-----+-----+---
        997AFC30AA56DA1F8B6CEC25B043CB08
        9070F43CA358D2148267E42BBE4EC302
        9
```

2. For the actual values of the SACCH MS Power Level: 0 to 31, see para. 4.3.5.
The set values in this screen are also set at the MS Power Level in other screens.
3. Set them so that Event Limit \leq Sample.
4. The actual RX Output Level is set according to following equation
Actual RX Output Level = RX Output Level setting + User Cal Factor
For User Cal Factor, the loss in the RF cable connecting the MT8801B and device under the test is set as a correction value.
5. When the MS's Call Processing Status is Communication, the RX Output Level Correction is applied to either CCH or TCH.
The Output Level of selected channel meets the level accuracy in MT8801B's specifications. (Para 1.5)

- Function keys

Main function key: None

Function keys:

[Back Screen]F12: Displays the previous screen

(2) Measuring the bit error rate: Bit Error Rate screen

The following describes how to measure the bit error rate (on Bit Error Rate screen) of the receiver by using the parameters set on the Setup RX Measure Parameter screen (see paragraph 4.3.7, (1)).

Some set items can be changed by using the function keys.

- Display the Bit Error Rate screen according to the following steps to measure the bit error rate.

Step	key operation	Description
1.	[Main Func on off]F6	Sets the Main Func on to display the Main Menu at the bottom of the screen.
2.	[TX&RX Tester]F1	Sets TX&RX Tester mode. The Setup Common Parameter screen appears.
3.	[RX Measure]F2	Displays the RX Measure menu.
4.	[Bit Error Rate]F7	Displays the Bit Error Rate screen.

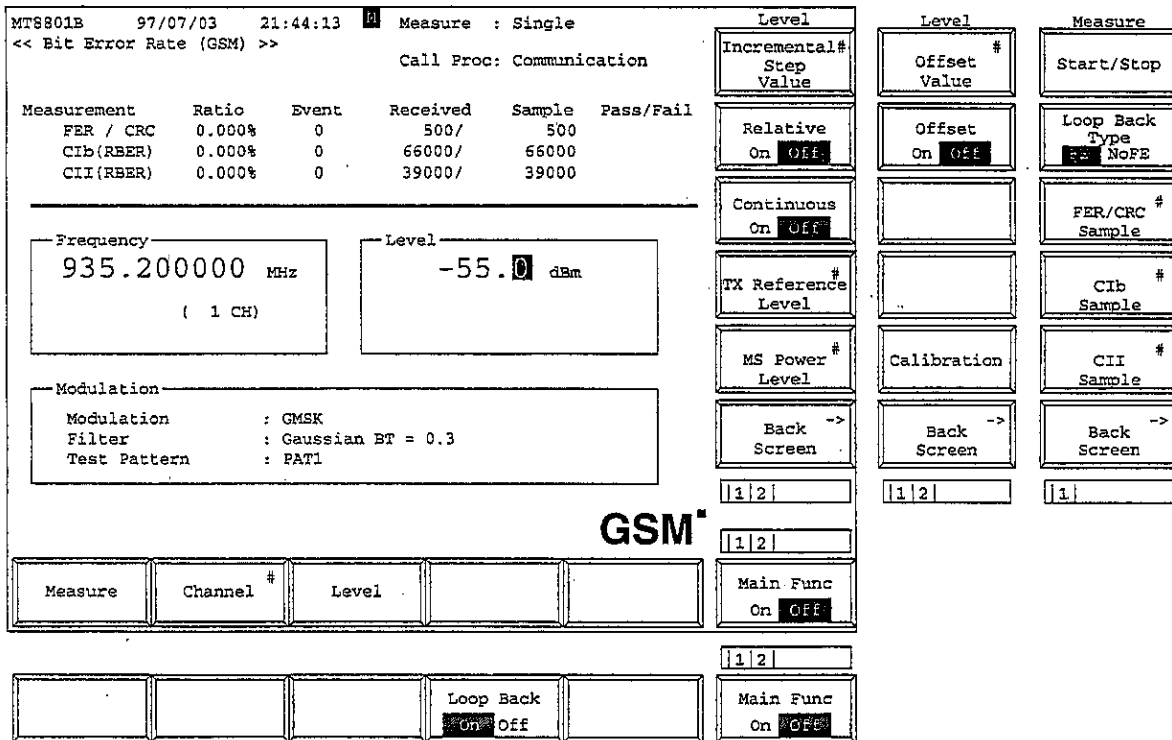

Fig. 4-28 Bit Error Rate Screen

When the DUT Control is set to None, the main function key [Channel]F2 changes to [Frequency]F2.

Additionally, [RF Level On Off]F4 and [Modulation On Off]F5 appear.

There is no 2nd page for the main function keys.

Frequency					
Incremental# Step Value					
Relative On Off					
Channel #					
Back → Screen					
i					
i					
Measure	Frequency	Level	RF Level On Off	Modulation On Off	Main Func On Off

Notes: 1. If synchronization failure occurs at start of or during measurement, Pattern Sync Loss is displayed. In this case, measurement stops until synchronization is established. When synchronization is established, measurement starts.

2. When the Measure mode is set to Single:

The intermediate measurement result is updated and displayed. When the number of data items reaches the specified number, measurement terminates.

When Measure mode is set to Continuous:

The measurement result is updated when measurement of the specified number of data items terminates. Measurement is then restarted.

• Main Function keys:

1st page

- [Measure]F1: Displays the Measure menu on F7 to F12.
- [Channel]F2: Displays a channel setting window.
When the DUT Control is set to None, this changes to [Frequency]F2.
- [Frequency]F2: The output frequency setup menu appears on F7 to F12.
When the DUT Control is set to Call Proc, this changes to [Channel]F2.
- [Level]F3: The output level setup menu appears on F7 to F12.
- [RF Level On Off]F4: Sets the output level On or Off. Initial value: Off
When the DUT Control is set to Call Proc, this is not displayed. (Always set to On.)
- [Modulation On Off]F5: Sets Modulation On or Off. Initial value: Off
When the DUT Control is set to Call Proc, this is not displayed. (Always set to On.)

2ndpage

- [Loop Back On Off]F4: Turns MS(mobile station to be tested) loop-back state On and Off.
When the DUT Control is set to None, this is not displayed.

• Function keys:

--- Measure menu ---

- [Start/Stop]F7: Starts (restarts) or stops measurement.
- [Loop Back Type]F8: Starts (restarts) or stops measurement.
- [FER/CRC Sample]F9: Changes the number of FER-measurement samples.
- [CIb Sample]F10: Changes the number of CIb-measurement samples.
- [CII Sample]F11: Changes the number of CII-measurement samples.
- [Back Screen]F12: Displays the previous screen.

-- Frequency menu --

When the DUT Control is set to None, Frequency menu is not displayed, and the Channel changing window appears.

- [Incremental Step Value]F7: Sets a step value when incrementing or decrementing an output frequency value by using the Step keys.
Range: 1 Hz to 3 GHz
Resolution: 1 Hz
Initial value: 1 MHz
- [Relative On Off]F8: Displays the relative output frequency based on the reference value immediately before setting Relative On.
Range: On, Off Initial value: Off
Note: If a frequency is set using a numeric key when this item is On, the value becomes the real output frequency.
Relative display value =
Value set by numeric key - Value before setting On

- [Channel]F9: Sets the channel number.
- [Back Screen]F12: Displays the previous screen.

--- Level menu ---

1st page

[Incremental Step Value]F7:

Sets a step value when incrementing or decrementing an output level by using the Step keys.

Range: 0.1 to 80 dB

Resolution: 0.1 dB

Initial value: 1 dB

[Relative On Off]F8:

Displays a relative output level based on the reference value (dB unit) immediately before setting Relative On.

Range: On, Off Initial value: Off

Note: If a level is set using a numeric key when this item is set On, the value becomes the real output level.

Relative display value =

Value set using a numeric key - Value before setting On

[Continuous On Off]F9:

Sets a mode in which an output level can be changed without an interrupt in the range of 20 dB. If a value immediately before setting Continuous On is assumed to be L0 dBm, the level can be changed by using the rotary knob without an interrupt in the range of 20 dB. (The Step and numeric keys are invalid.)

$(L0 - 20) \text{ dBm} \leq \text{Output level} \leq L0 \text{ dBm}$

[TX Reference Level]F10

Changes the reference level of the MT8801B to measure the transmission level of the MS.

[MS Power Level]F11

Changes the transmission level of the MS.

Not displayed when the DUT Control is set to None (See Paragraph 4.3.5).

[Back Screen]F12:

Displays the previous screen.

2nd page

[Offset Value]F7:

Sets an offset value in output level offset display mode. The loss in the RF cable connecting the MT8801B and receiver under test can be corrected by using this key. (See paragraph 4.3.1, (4).)

Range: -55.0 to 55.0 dB

Resolution: 0.1 dB

Initial value: 0 dB

[Offset On Off]F8:

Increases or decreases the real output level to display.

Displayed value = Real output level value + Offset value.

Range: On, Off Initial value: Off

Note: If a level is set using a numeric key when this item is On, the value becomes the displayed value.

Real output level value = Displayed value - Offset value

[Back Screen]F12:

Displays the previous screen.

4.3.8 Connection test: Call Processing mode

This paragraph describes the parameter setup (Setup Call Processing Parameter screen) and the connection test (Sequence Monitor screen).

(1) Setting parameters: Setup Call Processing Parameter screen

The following describes the parameter setup (Setup Call Processing Parameter screen) to conduct the connection test (Call Processing mode).

- Display the Setup Call Processing Parameter screen and set the parameters as shown below.

Step	Key operation	Description
1.	[Main Func On Off]F6	Sets Main Func to ON to display the main menu at the bottom of the screen.
2.	[TX&RX Tester]F1	Sets TX&RX Tester mode. The Setup Common Parameter screen appears.
3.	[Call Processing]F3	Displays the Call Processing menu.
4.	Next Menu[^]	Displays the 2nd page of the Call Processing menu.
5.	[Setup Call Proc Parameter]F7	Displays the Setup Call Processing Parameter screen.

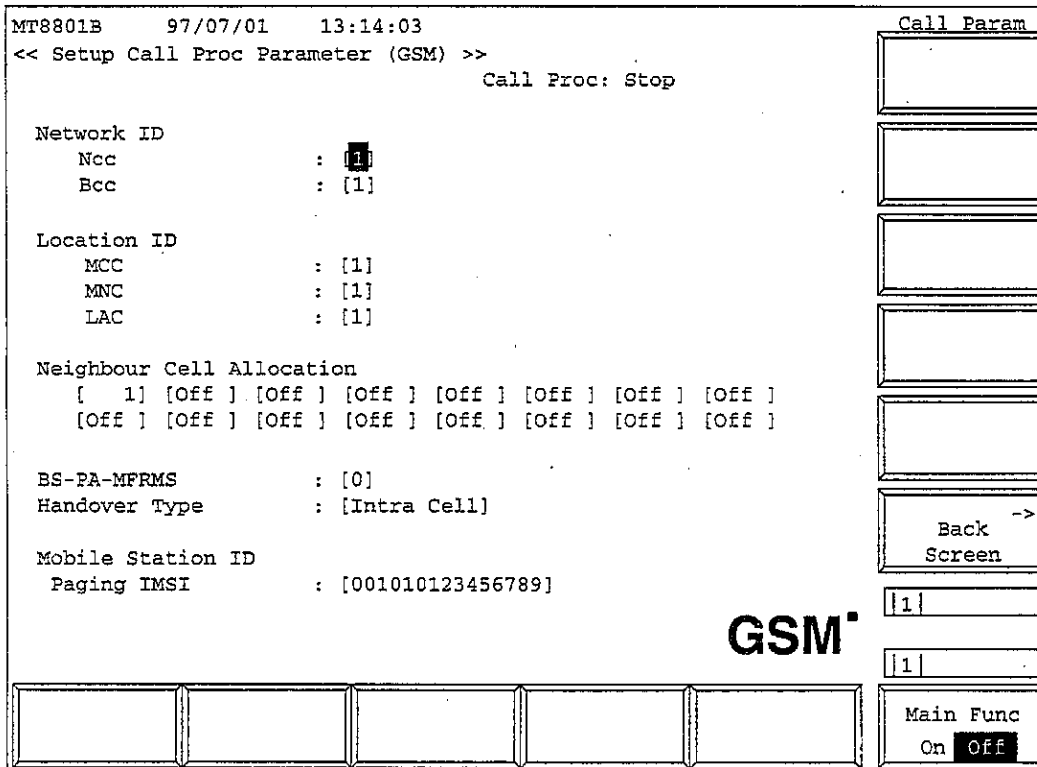

Fig. 4-29 Setup Call Processing Parameter Screen

- Set the following items:

Item	Range	Initial value
Network ID		
Ncc	0 to 7	1
Bcc	0 to 7	1
Location ID		
MCC	0 to 999	1
MNC	0 to 99	1
LAC	0 to 65535	1
Neighbour Cell Allocation		
	-1 to 124 (GSM)	-1 (off)
	-1 to 1023 (GSM/DCS1800, GSM/PCS1900)	
BS-PA-MFRMS	0 to 7	0
Handover Type	Intra Cell/Inter Cell (Sync)	Intra Cell
Mobile Station ID		
Paging IMSI	0 to 9999999999999999	

Note: The following shows the cases where the setup is enabled or disabled depending on the Call Processing status.

- List of settable items for each status

O: enabled X: disabled and opens error-message window.

	DUT Control:None	DUT Control:Call Proc MT8801 Stop	DUT Control:Call Proc Status 0	DUT Control:Call Proc Status	DUT Control:Call Proc Status 0
Ncc	O	O	X	X	X
Bcc	O	O	X	X	X
MCC	O	O	X	X	X
MNC	O	O	X	X	X
LAC	O	O	X	X	X
Paging IMSI	O	O	X	X	X
TMSI	O	O	X	X	X

status0 = Idle

status1 = Paging, RadioLink, Registration, Origination, Termination, Hand Over, Disc from NT,
Disk from MS, Radio Disc

status2 = Communication

- Main function keys: None
- Function keys
[Back Screen]F12 Displays the previous screen.

(2) Connection test --- Sequence Monitor screen

The following describes the connection test conducted according to the parameters set on the Setup CallProcessing Parameter screen.

- Display the Sequence Monitor screen and conduct the connection test.

Step	Key operation	Description
1.	[Main Func On Off]F6	Sets Main Func to ON to display the main menu at the bottom of the screen.
2.	[TX&RX Tester]F1	Sets TX&RX Tester mode. The Setup Common Parameter screen appears.
3.	[Call Processing]F3	Displays the Call Processing menu.
4.	[Sequence Monitor]F7	Displays the Sequence Monitor screen.

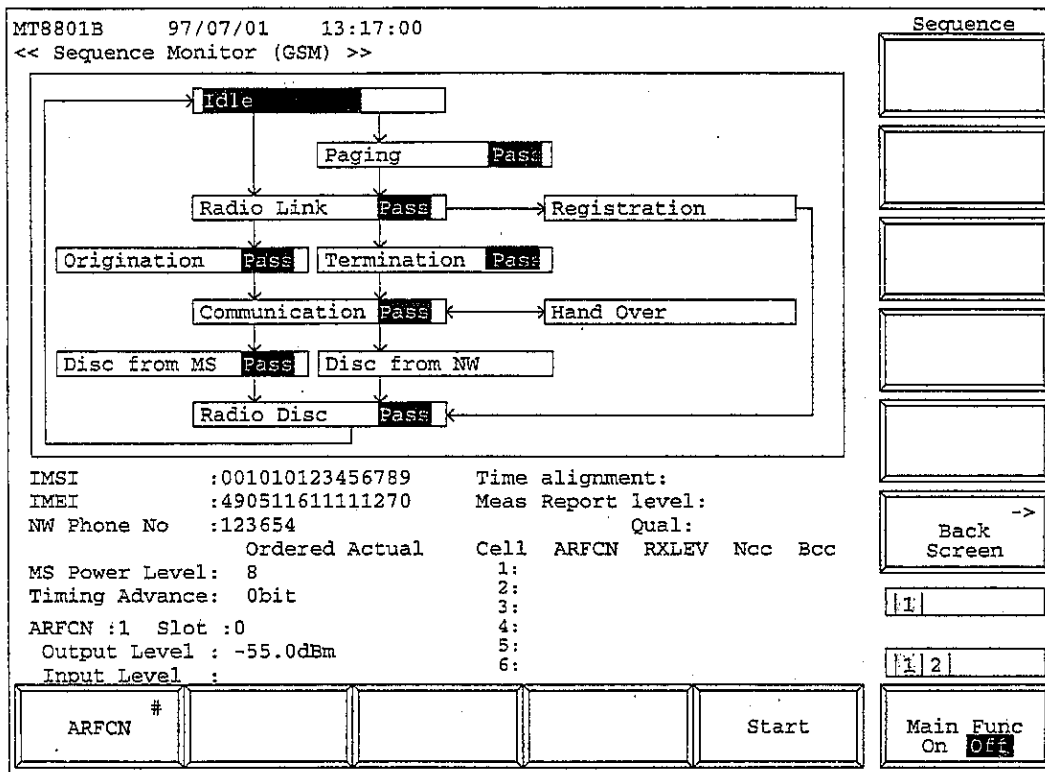
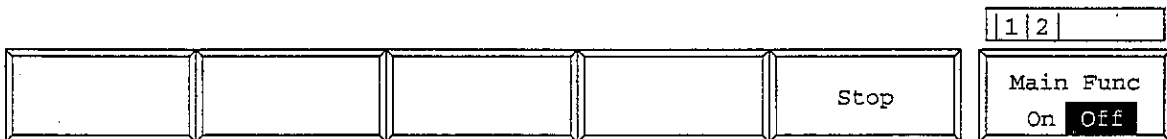

Fig. 4-30 Sequence Monitor screen

- 1st page of the main function keys on the Sequence Monitor screen

(1) When the MT8801B is the Call Processing status of Stop



(2) When the MT8801B is the Call Processing status of Start, and the MS is the Call Processing status of Idle

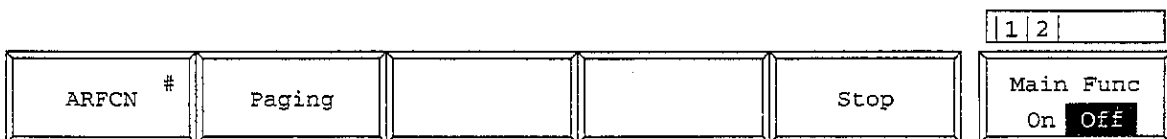

(3) When the MT8801B is the Call Processing status of Start, and the MS is the Call Processing status of Paging, Radio Link, Registration, Origination, Termination, Hand Over, Disc from MS or Radio Disc.

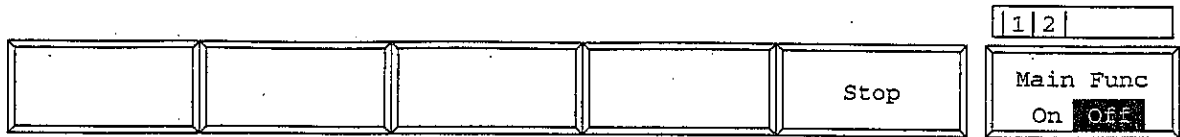

(4) When the MT8801B is the Call Processing status of Start, and the MS is the Call Processing status of Communication

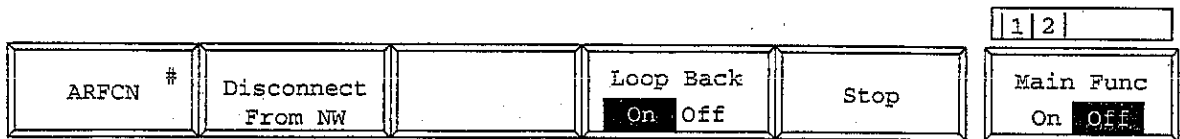

• 2nd page of the main function keys on the Sequence Monitor screen

(1) When the MT8801B is the Call Processing status of Stop

- The set value of the RX Output Level is executed when the [Start]F5 key on the first page of the main function keys is pressed.

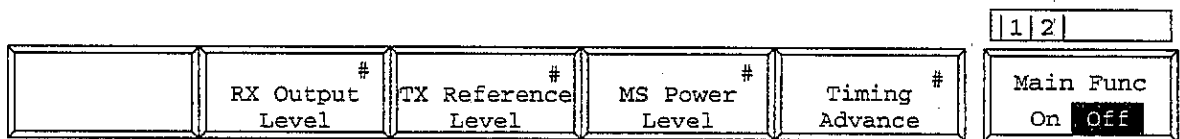

(2) When the MT8801B is the Call Processing status of Start, and the MS is the Call Processing status of Idle

- The set value of the RX Output Level is executed, immediately.

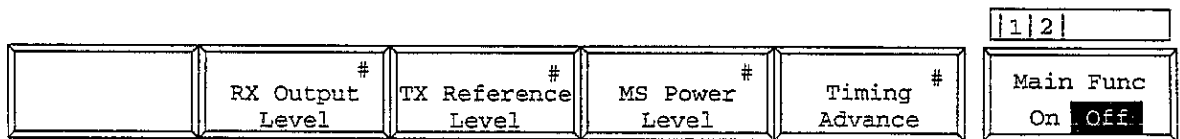

(3) When the MT8801B is the Call Processing status of Start, and the MS is the Call Processing status of Paging, Radio Link, Registration, Origination, Termination, Hand Over, Disc from MS or Radio Disc.

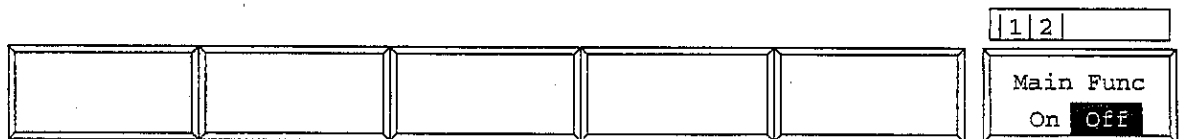

(4) When the MT8801B is the Call Processing status of Start, and the MS is the Call Processing status of Communication

- The set value of the RX Output Level is executed, immediately.

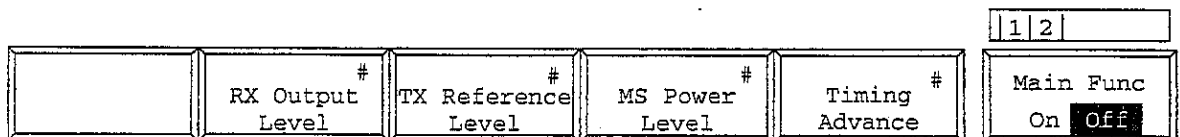

Notes: 1. Only the Time Alignment is a measured value, and others are the data from the MS.
 2. "Actual" indicates the actual data from the MS; "Ordered" indicates the setting values.

SECTION 4 OPERATION

• Main function keys

1st page

[ARFCN]F1

Opens the channel-number changing window to change the channel (ARFCN: Air RF Channel).

Appears when the MT8801B is the Call Processing status of Start, and the MS is the Call Processing status of Idle or Communication.

[Paging]F2

Pages the MS (mobile system under test).

Appears when the MT8801B is the Call Processing status of Start, and the MS is the Call Processing status of Idle.

[Disconnect From NT]F2

Disconnects the MS from the network.

Appears when the MT8801B is the Call Processing status of Start, and the MS is the Call Processing status of Communication.

[Loop Back On Off]F4

Turns on/off the loop-back (output) signal from the MS.

Appears when the MT8801B is the Call Processing status of Start, and the MS the Call Processing status of Communication.

[Start]F5

Changes the MT8801B status from Stop to start.

Appears when the MT8801B is the Call Processing status of Stop.

[Stop]F5

Changes the MT8801B status from Start to stop.

Appears when the MT8801B is the Call Processing status of Start.

2nd page Appears when the MT8801B is the Call Processing status of Stop. Also appears when the MT8801B is the Call Processing status of Start and then the MS is the Call Processing status of Idle or Communication.

[RX Output Level]F2

Changes the reception level of the MS (i.e. the output level of the MT8801B).

[TX Reference Level]F3

Changes the reference level of the MT8801B to measure the transmission level of the MS (i.e. the reception level of the MT8801B).

[MS Power Level]F4

Changes the transmission level of the MS.

[Timing Advance]F5

Changes the Timing Advance of the MS.

• Function keys:

None

4.3.9 Saving and recalling parameter data:

Save Parameter screen, Recall Parameter screen

Display the Save Parameter and Recall Parameter screens according to the following steps to save or recall parameters set for the transmitter and receiver test.

Step	key operation	Description
1.	[Main Func on off]F6	Sets the Main Func on. The first page of the Main Menu appears at the bottom of the screen.
2.	[Recall]F4	Sets Recall Parameter mode. The Recall Parameter screen appears. The Recall function key menu appears on F7 to F12.
2'	[Save]F5	Sets Save Parameter mode. The Save Parameter screen appears. The Save function key menu appears on F7 to F12.

MT8801B 97/07/01 13:31:29			Recall														
<< Recall Parameter >>			Previous Page														
<table border="1"> <thead> <tr> <th>Name</th> <th>Date</th> <th>Time</th> </tr> </thead> <tbody> <tr> <td>GSMTEST1.P00</td> <td>97-07-01</td> <td>13:26:20</td> </tr> <tr> <td>GSMTEST2.P01</td> <td>97-07-01</td> <td>13:27:10</td> </tr> </tbody> </table>		Name	Date	Time	GSMTEST1.P00	97-07-01	13:26:20	GSMTEST2.P01	97-07-01	13:27:10	<table border="1"> <thead> <tr> <th>Recall File</th> </tr> </thead> <tbody> <tr> <td>Directory : GSM Tester</td> </tr> <tr> <td>Recall Item : Parameter</td> </tr> </tbody> </table>		Recall File	Directory : GSM Tester	Recall Item : Parameter	Display Dir./Next Page	
Name	Date	Time															
GSMTEST1.P00	97-07-01	13:26:20															
GSMTEST2.P01	97-07-01	13:27:10															
Recall File																	
Directory : GSM Tester																	
Recall Item : Parameter																	
				File No. #													
		<table border="1"> <thead> <tr> <th>FD Information</th> </tr> </thead> <tbody> <tr> <td>Volume Label : *****</td> </tr> <tr> <td>Unused Area : 881152bytes</td> </tr> <tr> <td>Total Area : 1474560bytes</td> </tr> </tbody> </table>		FD Information	Volume Label : *****	Unused Area : 881152bytes	Total Area : 1474560bytes										
FD Information																	
Volume Label : *****																	
Unused Area : 881152bytes																	
Total Area : 1474560bytes																	
				1 2													
				1													
				Main Func On Off													

Fig. 4-31 Recall Parameter Screen

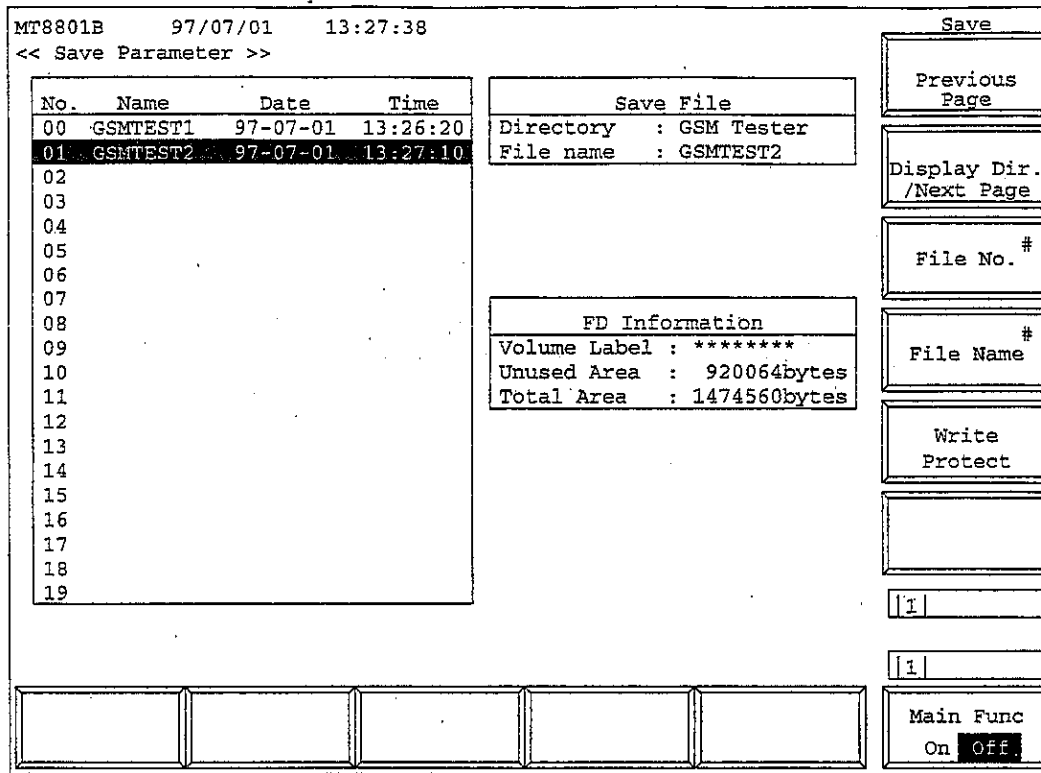

Fig. 4.32 Save Parameter Screen

- Floppy disk to be used:
 For saving and loading parameters and data, use the floppy disk described in Section 3. When the floppy disk is required to be formatted, use the File Operation screen in Paragraph 4.3.10.
- Notes when displaying the Save Parameter screen and Recall Parameter screen:
 Before pressing the [Save]F5 or [Recall]F4 function key, insert a floppy disk(FD) in the FD driver of the MT8801B. Then press the key. The MT8801B automatically starts the FD-driver operation.
- Screen display and function key display:
 Pressing the [Save]F5 or [Recall]F4 function key changes only the display of the F7 to F12 function keys. The screens (Figs. 4-31, 4-32) appear when the [Display Dir./Next Page] F8 key is pressed to display the contents of the FD. These screens also display the function keys used to select any directory and any file.
- Information to be saved and recalled:
 The [Save] and [Recall] keys on the main function keys saves and recalls the measurement parameters.

- Function keys on the Recall Parameter screen

Main function key: None

Recall function keys:

[Display Dir.]F8: Accesses the floppy disk and displays the directory of the parameter data file. The lower-order Recall menu appears. (This menu consists of two pages. Use the Next Menu [▲] key to scroll to the next page.)

**** 1st page****

[Previous Page]F7: Displays the previous page of the directory.

[Display Dir./Next Page]F8: Accesses the floppy disk and displays the next page of the directory.

[File No.]F9: Opens the window for entering the recall position (number) of the setup parameter data file.

0 to 99, Resolution: 1, Initial value: 0

[Back Screen]F12: Displays the previous screen.

**** 2nd page ****

[Select Display Mode]F7: Displays the Display Mode menu to select a display mode.

 [Wide]F7: Displays file numbers in ascending order from 0 regardless of whether all files are saved.

 [Narrow]F8: Skips the numbers of files not saved and displays only the numbers of saved files in ascending order.

 [return]F12: Returns to the previous menu.

[Back Screen]F12: Displays the previous screen.

[File No.]F9: Opens the window for entering the recall position (number) of the setup parameter file.

0 to 99, Resolution: 1, Initial value: 0

[return]F12: Returns to the previous menu.

SECTION 4 OPERATION

- Function keys on the Save Parameter screen

Main function key: None

Save function keys:

[Display Dir.]F8:	Accesses the floppy disk and displays the directory of the parameter data file. The low-order Save menu appears.
[Previous Page]F7:	Displays the previous page of the directory.
[Display Dir./Next Page]F8:	Accesses the floppy disk and displays the next page of the directory.
[File No.]F9:	Opens the window for entering the save position (number) of the setup parameter data file. 0 to 99, Resolution: 1, Initial value: 0
[File Name]F10:	Opens the window for entering the name of the parameter data file to be saved. The data file name consists of up to eight characters.
[Write Protect]F11:	Write-protects the specified parameter data file. An asterisk (*) is displayed at the end of the name of the write-protected file. If the specified parameter data file is already write-protected, this key cancels write protect. Note: This function can only be executed through panel operation.
[Back Screen]F12:	Displays the previous screen.
[return]F12:	Returns to the previous menu.

- Saving parameters and data

This paragraph describes how to save the measurement parameters of the MT8801B to a floppy disk.

Step	key operation	Description
1.		Insert a saving floppy disk(FD) into the FD driver on the bottom left of the MT8801B.
2.	[Main Func on off]F6	Sets Main Func to on. The Main Menu is displayed on the main function keys.
3.	[Save] F5	Changes to Save parameter mode. Displays the Save function keys in F7 to F12, and then moves to the Save screen for parameter and data.
4.		Searches the FD for parameter and data files, and displays them on the screen. Proceed to Step 5 below.
(Under state where the Save menu is displayed)		
5.	[Display Dir./Next Page]F8	Displays existing files to check the number of the file to be saved.
6.	[File Name]F10	Sets the file name used for save within 8 alphanumeric characters if necessary.
7.		Check the number of the file to be saved and the file status (whether the file exists and whether the file is write-enabled). To write-enable the file, proceed to Steps 8a and later. Otherwise, proceed to Step 9.
8a.	Cursor [^] and [v]	Select the file to be write-enabled.
8b.	[Write Protect] F11	Write-enables the file for over-writing.
9.	[File No.] F9	Specify the number of the file to be saved.
10.	[Set]	Saves the file.
11.	[Back Screen]F12	Returns to the previous screen.

- Write-protecting or write-enabling the file to be saved

This paragraph describes how to write-protect or write-enable the file containing data in the Save screen.

Step	key operation	Description
1.		Execute the Steps 1 to 4 of the saving procedure in the previous paragraph to display the Save menu.
2.	[Display Dir./Next Page]F8	Displays the existing files. Check the number of the file to be saved.
3.	Cursor [^], [v]	Select the file to be write-enabled.
4.	[Write Protect]F11	Write-protects or write-enables the file to be saved.
5.	[Back Screen]F12	Returns to the previous screen.

- Recalling parameters and data

This paragraph describes how to recall measurement parameters from the floppy disk.

Step	key operation	Description
1.		Insert a recall floppy disk(FD) into the FD driver at the bottom left of the MT8801B.
2.	[Main Func on off]F6	Sets Main Func to on. Displays Main Menu on the main function keys.
3.	[Recall]F5	Changes to Recall Parameter mode. Displays the Recall function keys in F7 to F12, and moves to the Recall screen for parameter and data. Searches the FD for parameter and data files, and displays them on the screen.
4.		Proceed to Step 5 below.

(Under state where the Recall menu is displayed)

5.	[Display Dir./Next Page]F8	Displays the directory containing the file to be recalled. Check the file to be recalled.
6.	Cursor[^][v]	Select the file to be recalled.
7.	[File No.]F9 (The file to be recalled can be specified by the file number, too.)	Sets the number of any file to be recalled.
8.	[Set]	Confirms the file to be recalled. The MT8801B reads the specified file. Then, returns to the previous screen automatically.

- Changing the recall-file display format(WIDE/NARROW)

This paragraph describes how to change the recall-file display format(WIDE/NARROW).

Step	key operation	Description
1.		Execute the Steps 1 to 5 of the recalling procedure in the previous paragraph to display the recalled file.
2.	Next Menu [^]	Displays the second page of the function keys.
3.	[Select Display Mode]F7	Displays the file display format selection menu.
4.	[Wide]F7 or [Narrow]F8	Specify the display format.
5.	[return]F12	Returns to the previous menu.

4.3.10 Operating the file: File Operation screen

To access the floppy disk and display the parameter file directory, delete or write-protect the parameter file, and initialize the floppy disk; display the File Operation screen according to the following steps.

Note: This function can only be executed through panel operation.

Step	key operation	Description
1.	[Main Func on off]F6	Sets the Main Func on. The Main Menu appears at the bottom of the screen
	Next Menu [◀]	Displays the second page of the Main Menu.
2.	[File Operation]F4	Sets File Operation mode. The File Operation screen appears. The File function key menu appears on F7 to F12.

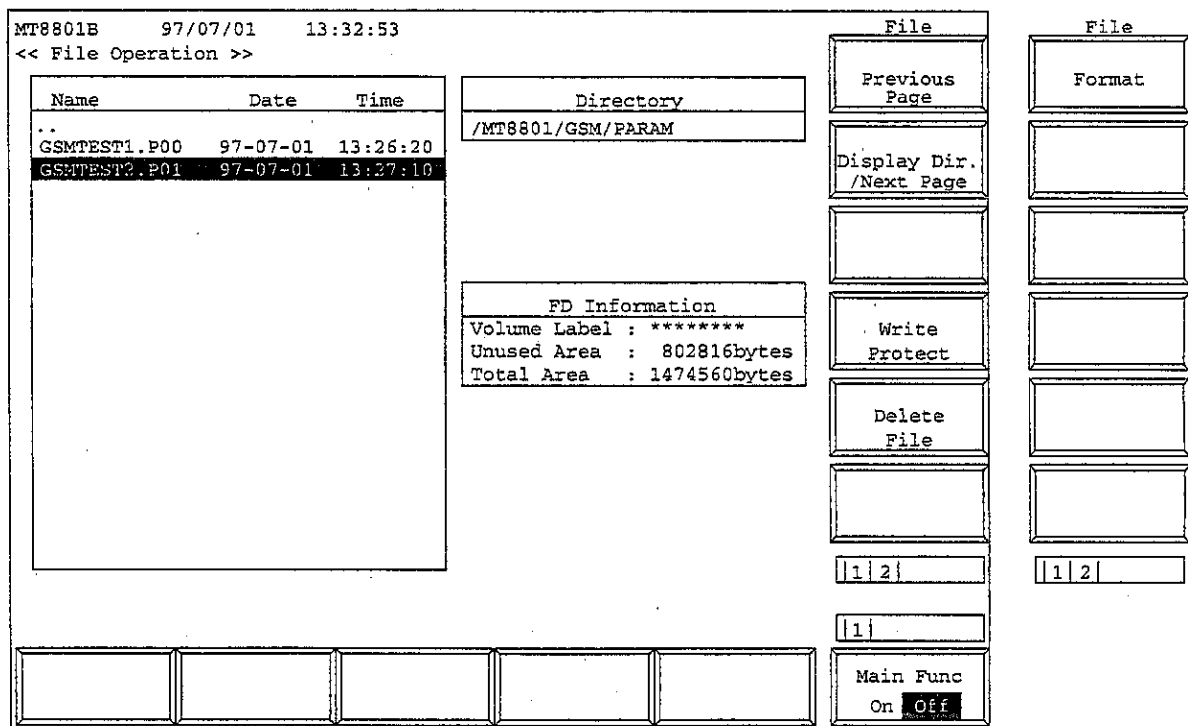

Fig. 4-33 File Operation Screen

Note: Use the floppy disk described in Section 3.

• Functions keys on the File Operation screen

Main function key: None

Function keys: 2 pages. Use the Next Menu [▲] key to scroll to the next page.

** 1st page **

[Previous Page]F7: Displays the previous page of the directory.

[Display Dir./Next Page]F8: Accesses the floppy disk and displays the next page of the directory.

[Write Protect]F10: Write-protects the specified parameter data file.
 An asterisk (*) is displayed at the end of the name of the write-protected file.
 If the specified parameter data file is already protected, write protect can be canceled by pressing this key.
 Note: This function can only be executed through panel operation.

[Delete File]F11: Opens the window for entering the position (number) of the parameter data file to be deleted.
 Setup range: 0 to 99 (integer)
 Initial value: 0

** 2nd page **

[Format]F7: Initializes the floppy disk to the specified type. The initialization format is MS-DOS 1.44 MB or 720 kB.
 Note: The format is MS-DOS 1.44 MB or 720 kB. Use the 2HD or 2DD type of 3.5-inch floppy disk.

• Displaying files

This paragraph describes how to display the files in FD.

Step	key operation	Description
1.		Insert a floppy disk(FD) into the FD driver at the bottom left of the MT8801B.
2.	[Main Func on off]F6	Turn the Main Func on to display the main function keys.
3.	Next Menu [◀]	Displays the second page of the main function keys.
4.	[File Operation]F4	Moves to the File Operation screen. Accesses the FD to display the root directory.
5.	Cursor [^] [v]	Specify the directory to be required.
6.	[Set] or [Enter]	Moves to the specified directory to display its contents.
7.		Repeat the Steps 5 and 6 above to display the required directory.

Note: The sub-directories and file name under the selected directory are displayed in the frame on the left of the screen.
 For directories, only their names are displayed in the "Name" field.
 For files, Name/Date/Time are displayed.
 The Directory field at the upper right of the screen displays the layer and location of the selected directory.

- Write-enabling/write-protecting files

This paragraph describes how to change the file write mode between the write-protected and write-enabled modes.

Step	key operation	Description
1.		Select the directory of the desired file by the displaying-file procedure above.
2.	Cursor [^] [v]	Specify the file.
3.	[Write Protect]F10	Changes the file write mode.

- Deleting files

This paragraph describes how to delete the parameter/data files.

Step	key operation	Description
1.		Select the directory of the desired file by the displaying-file procedure above.
2.	Cursor [^] [v]	Specify the file.
3.	[Delete File]F11	Opens the confirmation window.
4.	Cursor [^] [v]	Select Yes or No. "Yes" deletes the specified file.

Note: Once a file is deleted, it cannot be restored.

- Initializing(formatting) floppy disk

This paragraph describes how to initialize a floppy disk.

Step	key operation	Description
1.		Insert a floppy disk(FD) into the FD driver at the lower left of the MT8801B. The acceptable FD is the 2HD(1.44 M-bytes) or 2DD(720 k-bytes) type.
2.	Next Menu [^]	Displays the second page of the function keys.
3.	[Format]F7	Initializes the floppy disk. During initialization, a window indicating initialization appears on the screen.
4.	Next Menu [^]	Returns to the first page of the function keys.

Note: Once a floppy disk is initialized, the data recorded on the disk is all lost.

4.3.11 Screen hard copy ... Copy

The copy function transfers a screen display to the printer or floppy disk. Specify a transfer destination and mode on the Instrument Setup screen. Press the Copy key on the front panel to activate the Copy function. While the Copy function is operating, operations (including remote control) such as measurement or internal setting are disabled.

(1) Transfer to the printer

If Copy is set to the printer on the Instrument Setup screen, screen display can be printed via the Parallel interface on the rear panel. Printers using the ESC/P command system can be used.

(2) Transfer to the floppy disk

If Copy is set to BMP on the Instrument Setup screen, the floppy disk driver on the front panel can be used to store data displayed on the screen in the floppy disk. Paragraph 4.3.10 describes the floppy disks that can be used. Data created on the floppy disk is the image file of the monochrome BMP data format. While the Copy is being executed, the name of the created file "RCA_***.BMP" is displayed on the bottom of the screen (***) is a number beginning with 000).

(Reference) Number of storable BMP files

2DD (720K bytes): Up to 18

2HD (1.44M bytes): Up to 37

4.3.12 Settings relating to remote control and panel key control

1. Remote control interfaces

The remote control interfaces of the MT8801B are classified into the GPIB interface and serial interface (RS-232C interface). Select an interface used on the Instrument Setup screen (see paragraph 4.3.3).

2. Remote control and panel control keys

The keys and lamps described in this section are assigned on the front panel as exclusive keys and lamps.

1) REMOTE lamp and LOCAL key

The REMOTE lamp indicates that the MT8801B is controlled remotely using the GPIB interface. When the MT8801B is controlled remotely from an external controller via the GPIB interface, the REMOTE lamp lights. While the REMOTE lamp is on, key entry and rotary encoder entry from the front panel are disabled. The LOCAL key is used to cancel the remote control status of the GPIB interface. When the LOCAL key is pressed, the REMOTE lamp goes off and key entry and rotary encoder entry from the front panel are enabled.

2) PANEL LOCK key

The PANEL LOCK key is used to enable and disable key entry and rotary encoder entry from the front panel. Use the PANEL LOCK key to prevent an incorrect operation on the front panel for automatic measurement or status holding. When the panel is locked, the red lamp on the PANEL LOCK key lights.

3. Remote control status

There are the following differences between control statuses of the two remote control interfaces that can be used with the MT8801B:

1) Remote control status by GPIB

If GPIB is used for remote control, the REMOTE lamp on the left of the front panel lights. While the REMOTE lamp is on, key entry and rotary encoder entry from the front panel are disabled. To change the GPIB control status to the front panel entry status, execute the following steps:

1-1) Halt the GPIB control.

1-2) If the REMOTE lamp is on, press the LOCAL key to cancel the REMOTE status.

2) Remote control status by RS-232C

If RS-232C is used for remote control, the REMOTE lamp on the left of the front panel does not light. During the remote control using RS-232C, key entry and rotary encoder entry from the front panel are enabled (remote control operations can be known by the change of display on the LCD screen). Therefore, during a remote control operation using RS-232C, be careful of incorrect operation caused by entry from the front panel.

SECTION 5

PERFORMANCE TESTS

This section lists the equipment used in performing the MT8801B performance tests, and explains the setup and the performance test items.

TABLE OF CONTENTS

5.1	Requirement for Performance Tests	5-3
5.2	Instruments Required for Performance Test	5-4
5.3	Performance Tests	5-5
5.3.1	Reference oscillator frequency stability	5-5
	(1) Specifications	5-5
	(2) Test instruments	5-5
	(3) Setup	5-5
	(4) Procedure	5-6
5.3.2	Frequency/modulation measurement accuracy	5-7
	(1) Specifications	5-7
	(2) Test instruments	5-7
	(3) Setup	5-7
	(4) Test procedure: frequency/modulation accuracy	5-8
5.3.3	Transmission power measurement accuracy	5-9
	(1) Specification	5-9
	(2) Test instrument	5-9
	(3) Setup	5-9
	(4) Test procedure: transmission power measurement accuracy	5-10
5.3.4	Signal-generator frequency accuracy	5-11
	(1) Specifications	5-11
	(2) Test instrument	5-11
	(3) Notes on test	5-11
	(4) Setup	5-11
	(5) Procedure	5-11

5.3.5	Signal-generator output level accuracy	5- 12
(1)	Specifications	5-12
(2)	Test instruments	5-12
(3)	Notes on test	5-12
(4)	Setup	5-12
(5)	Procedure	5-13
5.3.6	Signal-generator modulation accuracy	5-1 4
(1)	Specification	5-14
(2)	Test instrument	5-14
(3)	Setup	5-14
(4)	Procedure	5-14
5.3.7	Example of performance test result entry sheet	5-15

5.1 Requirement for Performance Tests

The performance tests are carried out as a part of preventive maintenance to prevent deterioration of the MT8801B.

Use the performance test procedures at acceptance inspection, periodic inspection, and after repair of the MT8801B.

Do the important parts of preventive maintenance periodically. This section explains the following test procedures:

- Reference oscillator frequency stability
- Frequency/modulation measurement accuracy
- Transmission power measurement accuracy
- Signal-generator frequency accuracy
- Signal-generator output level accuracy
- Signal-generator modulation accuracy

For important evaluation items, execute the performance tests at regular intervals for preventive maintenance. We recommend that the performance be inspected regularly once or twice a year.

If the specifications are not met in the performance tests, please contact the Service Department of Anritsu Corporation.

5.2 Instruments Required for Performance Test

The instruments required for performance tests are shown below.

Instruments Required for Performance Test

Recommended instrument name (model name)	Required performance†	Test item
Synthesized signal generator (MG3633A)	<ul style="list-style-type: none"> • Frequency range: 100 MHz to 1 GHz 1 Hz resolution • Output level range: -20 to +10 dBm Resolution of 0.1 dB possible • SSB phase noise ≤ -130 dBc/Hz (at 10 kHz offset) • Second harmonic ≤ -130 dBc • External reference input (10 MHz) 	Frequency/modulation accuracy Transmission power measurement accuracy
Power Meter (ML4803A)	<ul style="list-style-type: none"> • Main-frame accuracy: ± 0.02 dB • Frequency range: 100 kHz to 8.5 GHz (depending on the power sensor type) 	Frequency/modulation accuracy Output level accuracy
Power Sensor (MA4601A)	<ul style="list-style-type: none"> • Frequency range: 10 MHz to 3 GHz • Measurement power range: -30 to +20 dBm • Input connector: N type 	Frequency/modulation accuracy
Power Sensor (MA4602A)	<ul style="list-style-type: none"> • Frequency range: 10 MHz to 3 GHz • Measurement power range: -70 to -20 dBm • Input connector: N type 	Frequency/modulation accuracy Output level accuracy
Fixed attenuator (MP721B)	<ul style="list-style-type: none"> • Att: 6 dB • VSWR: < 1.2 	Transmission power measurement accuracy
Frequency counter (MF1603A)	<ul style="list-style-type: none"> • 100 kHz to 3 GHz • Number of display digits: 10 • Resolution: 1 Hz • External reference input: (10 MHz) possible 	Reference oscillator frequency accuracy Carrier frequency
Digital mobile radio transmitter tester (MS8604A)	<ul style="list-style-type: none"> • Residue phase error: 0.5 degrees rms 	Modulation accuracy
Frequency standard	<ul style="list-style-type: none"> • Frequency: 10 MHz • Stability: $\leq 1 \times 10^{-9}$ 	Reference-oscillator frequency stability

†Extracts part of performance which can cover the measurement range of the test item.

5.3 Performance Tests

Do not start the performance tests until the equipment to be tested and the measuring instruments have warmed up for at least 30 minutes and the MT8801B completely stabilized. Conduct the test at room temperature. Keep AC supply voltage fluctuations, noise, vibration, dust, humidity and any other factor which can affect results to a minimum.

5.3.1 Reference oscillator frequency stability

This test tests the frequency stability of the 10 MHz crystal oscillator used as the reference oscillator. Measure the frequency changes after 24-hour operation at 25°C (aging rate) and at 0 and 50°C (temperature characteristics).

(1) Specifications

Reference oscillator

- Frequency: 10 MHz
- Aging rate: $\leq 2 \times 10^{-8}/\text{day}$ (After 24-hour operation, 25°C \pm 5°C)
- Temperature stability: $\pm 5 \times 10^{-8}$ (0°C to 50°C, reference at 25°C)

(2) Test instruments

- Frequency counter: MF1603A
- Frequency standard: with stability of $\leq \pm 1 \times 10^{-9}$

(3) Setup

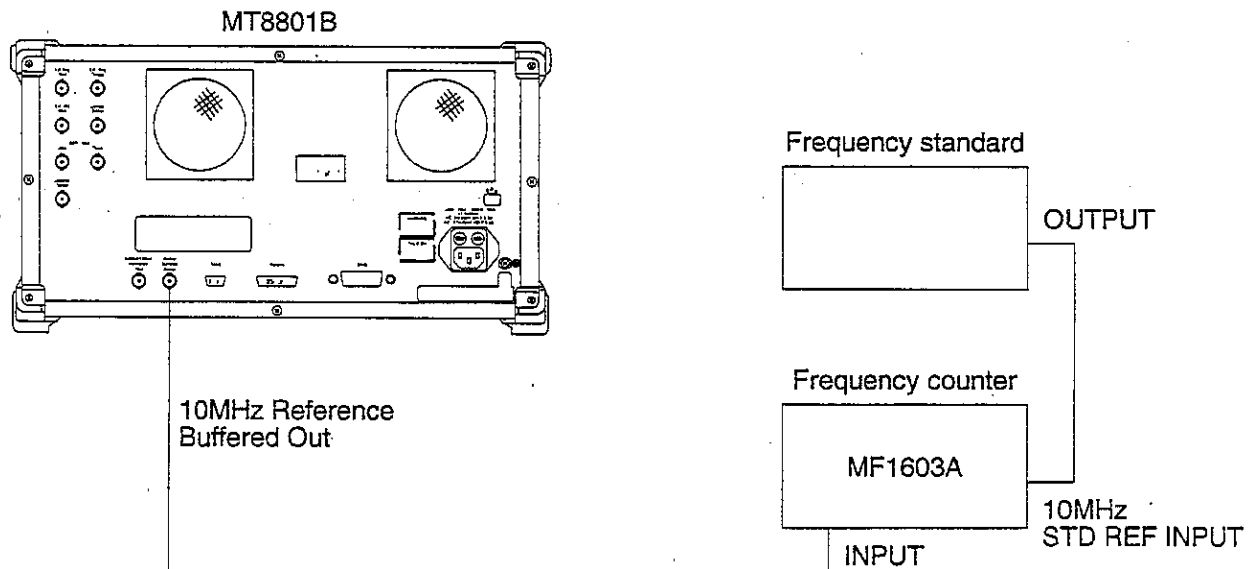

Reference Oscillator Frequency Stability Test

(4) Procedure

Aging rate: Test this at an ambient temperature change less than $\pm 2^{\circ}\text{C}$ in a vibration-free place.

Step	Procedure
1.	Set the reference signal changeover switch (FREQ STD:INT/EXT) on the MF1603A rear panel to EXT.
2.	Set the power supply switch on the MT8801B rear panel to On. Then, set the Power switch on the MT8801B front panel to On.
3.	Measure the frequency of the output from the 10 MHz Reference Buffered Out connector using the MF1603A after 24-hour operation with 0.001 Hz digit resolution.
4.	Measure the frequency of the same output using the MF1603A after 24 hours from the measurement in step 3.
5.	Calculate the stability using the following equation
	$\text{Frequency stability} = \frac{(\text{MF1603A reading in step 4}) - (\text{MF1603A reading in step 3})}{(\text{MF1603A reading in step 3})}$

Temperature stability: Test this in a vibration-free constant-temperature chamber.

Step	Procedure
1.	Set up the MT8801B in a constant-temperature chamber at 25°C .
2.	Set the Power switches on the MT8801B rear and front panels to On, and wait until the MT8801B internal temperature stabilizes, and wait approx. 1.5 hours after the chamber temperature stabilizes.
3.	When the internal temperature stabilizes, measure the frequency of the output from the 10 MHz Reference Buffered Out connector of the MT8801B using the MF1603A with 0.001 Hz digit resolution.
4.	Change the chamber temperature to 50°C .
5.	When the chamber temperature and the MT8801B internal temperature re-stabilize, measure the frequency using the MF1603A.
6.	Calculate the stability using the following equation:
	$\text{Frequency stability} = \frac{(\text{MF1603A reading at } 50^{\circ}\text{C}) - (\text{MF1603A reading at } 25^{\circ}\text{C})}{(\text{MF1603A reading at } 25^{\circ}\text{C})}$
7.	Change the chamber temperature to 0°C and repeat steps 5 and 6

5.3.2 Frequency/modulation measurement accuracy

Input an unmodulated signal from signal generator 1 with a shifted frequency, and use it as a signal pseudo-modulated with data "11".

(1) Specifications

- Carrier frequency accuracy: $\pm(\text{Reference crystal oscillator accuracy} + 10 \text{ Hz})$
- residue phase error accuracy: $\leq 0.5 \text{ degrees rms}, \leq 2 \text{ degrees peak}$

(2) Test instruments

- Synthesized signal generator: MG3633A

(3) Setup

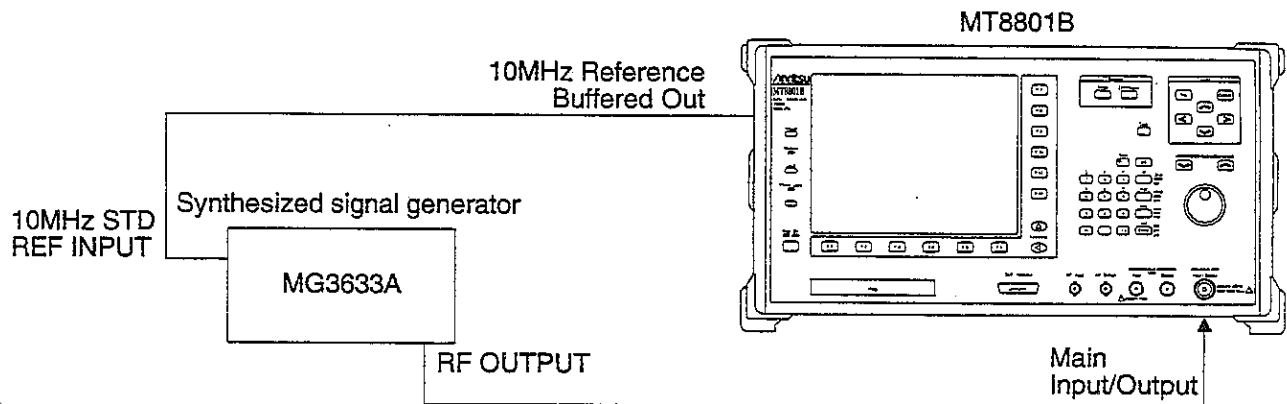

(4) Test procedure: frequency/modulation accuracy

Step	Procedure
1.	Set the MG3633A* ¹ Signal Generator as shown below: FREQUENCY: Frequency shown in the table* ² + 67.70833 kHz* ³ Unmodulated LEVEL: +10 dBm
2.	Set the MT8801B as shown below: RF Input/Output: Main: Specify this item on the Instrument Setup screen. DUT Control: None: Set this item on the Setup Common Parameter screen. Tx Measure Ref level: +10 dBm: Set this item on the Setup Common Parameter screen. Measuring Object: CONTINUOUS: Set this item on the Setup Common Parameter screen. Tx Measure Frequency: Frequency shown in the table: Set this item on the Setup common Parameter screen.
3.	Connect the MG3633A output to the MT8801B Main connector.
4.	Press the [Modulation Analysis] (F7) key of the MT8801B to read the indicated carrier frequency error and RMS phase error and peak phase error. The read RMS phase error and peak phase error represents the residual phase error of the MT8801B.

*1 The typical residue phase error of the MG3633A is 0.2 degree rms and 0.5 degree peak.

*2 See section 5.16.

*3 The frequency deviation when the modulation data is all-1 is calculated, as below:

$$67.70833 \text{ kHz} = \text{Bit rate}/4 = 270.833 \text{ kHz}/4$$

*Unit w/ system set to IS136 (ALL MEASURE)
 Had to be set to GSM*

5.3.3 Transmission power measurement accuracy

This test tests the power measurement function using the unmodulated, continuous wave supplied from the signal generator.

(1) Specification

- Transmission power accuracy: $\pm 10\%$

(2) Test instrument

- Signal generator: MG3633A

(3) Setup

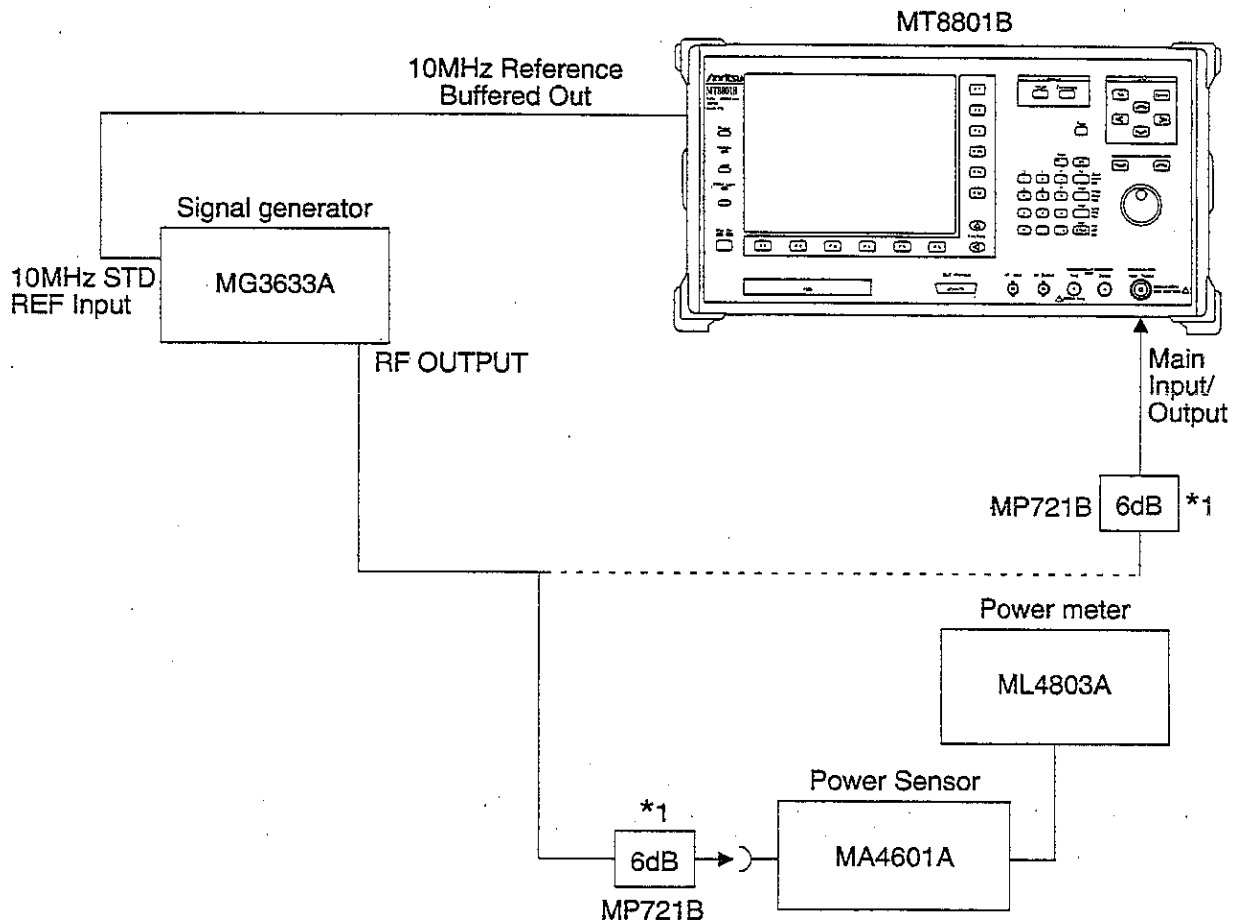

*1 The MP721B is used to improve the impedance matching of the MG3633A

(4) Test procedure: transmission power measurement accuracy

Step	Procedure
1.	Set the MG3633A Signal Generator as shown below: FREQUENCY 1,000 MHz OUTPUT LEVEL +16 dBm
2.	Connect the MG3633A output to the MA4601A Power Sensor, and measure the output level of the MG3633A with the ML4803A Power Meter.
3.	Set the MT8801B as shown below: RF Input/Output: Main Set in the Instrument Setup screen. DUT Control: None Set in the Setup Common Parameter screen. TX Measure REF Level: +10 dBm Set in the Setup Common Parameter screen. TX Measure Frequency: 1000 MHz Set in the Setup Common Parameter screen. Measuring Object: Continuous Set in the Setup Common Parameter screen.
4.	Press the [Power Meter]F12 key of the MT8801B to display the Power Meter screen.
5.	Press the [Zero Set]F11 key to calibrate the zero point.
6.	Connect the MG3633A output to the MT8801B Main connector.
7.	Press the [Adjust Range]F10 key, then read the measured value.
8.	Display the Setup Common Parameter screen on the MT8801B, and press the [RF Power]F9 key to change to the RF Power screen.
9.	Press the [Manual Calibration]F7 key to calibrate the MT8801B on the RF Power screen.
10.	Read the measured results(TX power).

5.3.4 Signal-generator frequency accuracy

Check the carrier frequency accuracy.

(1) Specifications

- Accuracy: Accuracy of reference frequency ± 100 mHz

(2) Test instrument

- Frequency counter: MF1603A

(3) Notes on test

The value indicated on the counter may contain an error of ± 1 count.

(4) Setup

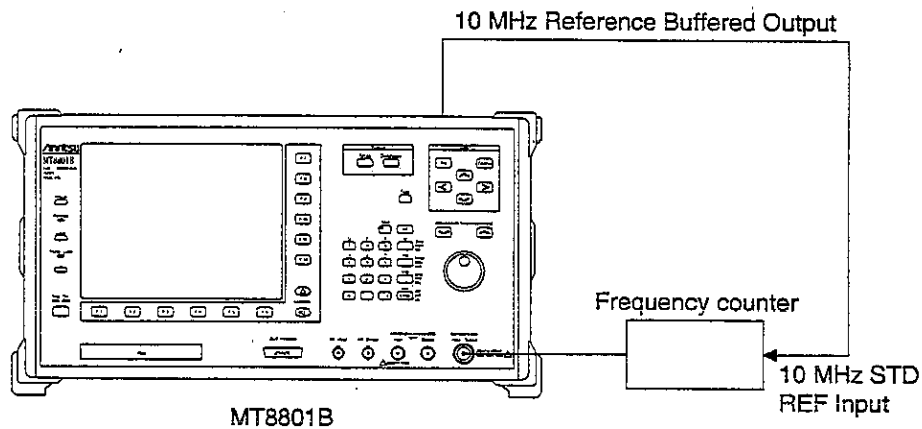

(5) Procedure

Step	Procedure
1.	Set the DUT Control to None on the Setup Common Parameter screen of the MT8801B.
2.	Set the MT8801B to RX Measure mode.
3.	Press the [BER Measure] (F6) key of the MT8801B.
4.	Set the MT8801B frequency to 10 MHz, and set the output level to -28 dBm, and the modulation to Off.
5.	Confirm that the frequency counter reading indicates $10 \text{ MHz} \pm 100 \text{ mHz}$

5.3.5 Signal-generator output level accuracy

(1) Specifications

Connector	Output level	10 MHz to 1 GHz	>1 GHz
Main Input/Output	-123 to -28 dBm -133 to -123.1 dBm	±1.5 dB ±3 dB	±2 dB ±4 dB

(2) Test instruments

- Power meter: ML4803A
- Power sensors: MA4602A

(3) Notes on test

Connect the MA4602A Power Sensor directly to the Main Input/Output connector.

(4) Setup

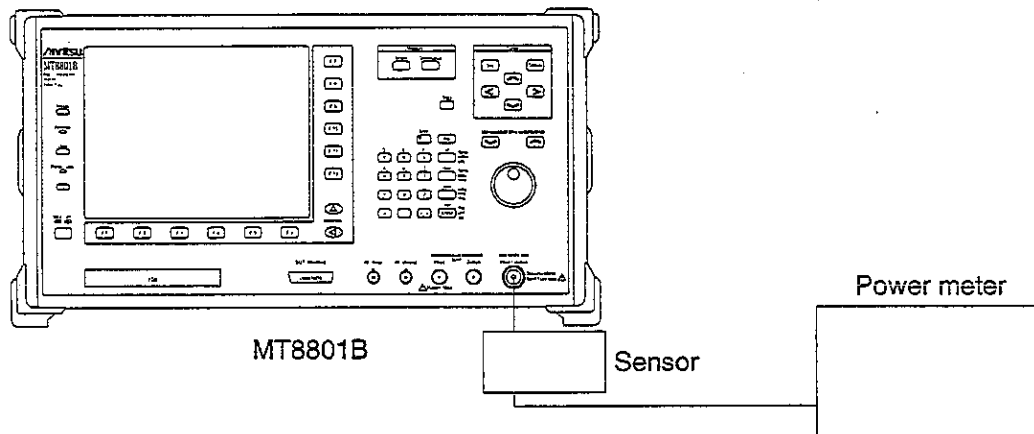

(5) Procedure

Step	Procedure
1.	Set the DUT Control to None on the Setup Common Parameter screen of the MT8801B.
2.	Press the [BER Measure]F6 key of the MT8801B.
3.	Press the [BER Measure]F6 key of the MT8801B.
4.	Set the [RF Off] key of the MT8801B to OFF.
5.	Adjust the zero point of power meter ML4803A and calibrate the sensor sensitivity.

Frequency (MHz)	0.3	1.0	3.0	10.0	30.0	100	300	1000	1500	2000	3000
Measured output level (dBm)											
Difference from -30 dBm (dB)											
Measurement uncertainty (dB)	± 0.18	± 0.18	± 0.18	± 0.18	± 0.18	± 0.18	± 0.18	± 0.18	± 0.18	± 0.18	± 0.18

6. Set the output level of the MT8801B to a measurement value (e.g. -30 dBm).
7. Press the F5 key of the MT8801B to set the modulation to OFF.
8. Set the MT8801B to the required frequency (e.g. one of the frequency shown in the above table).
9. Set the sensor calibration coefficient of the power meter, and measure the output level of the MT8801B.
10. Record the difference between the read value and -30 dBm.
11. Repeat steps 8 to 9, and check that the difference between the output level and the set value is within the specified range.

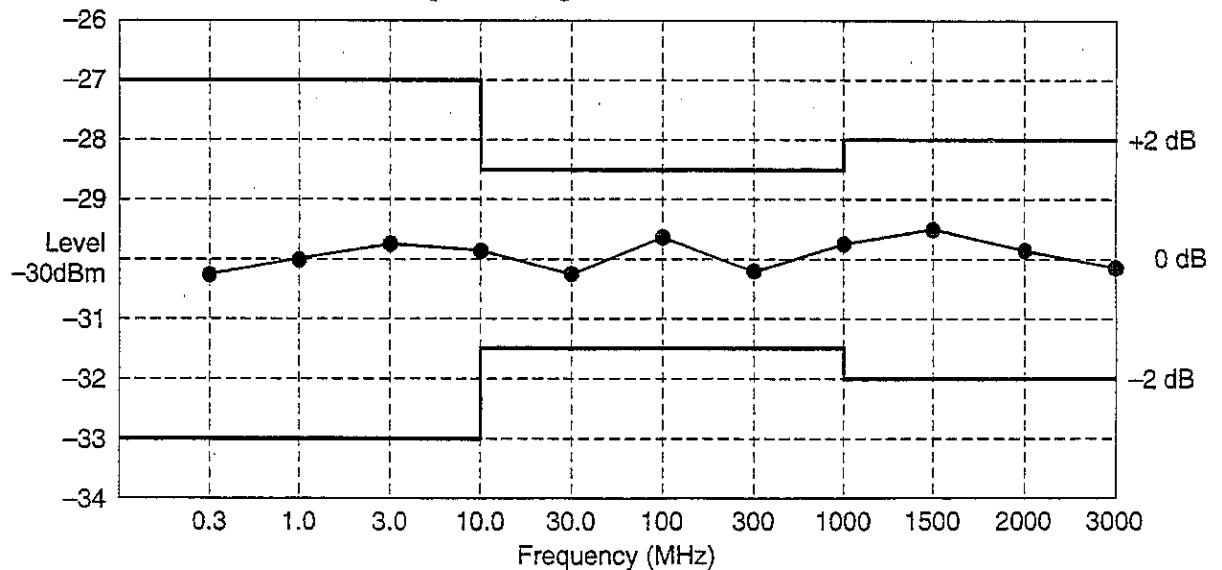

5.3.6 Signal-generator modulation accuracy

(1) Specification

- Modulation accuracy: Phase error: ≤ 2 degrees rms

(2) Test instrument

- Digital mobile radio transmitter tester: MS8604A

(3) Setup

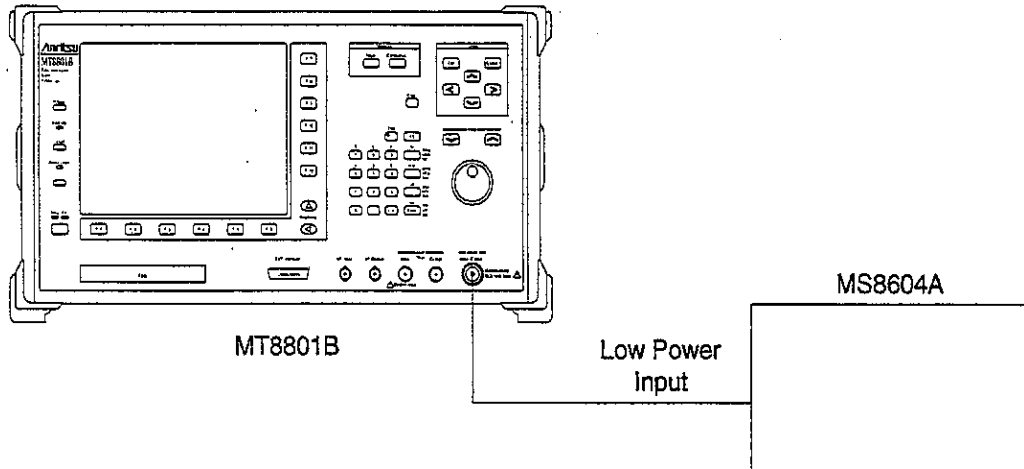

(4) Procedure

Step	Procedure
1.	Set the DUT Control to None on the Setup Common Parameter screen of the MT8801B.
2.	Set the MT8801B to RX Measure mode, and set parameters of the signal etc.
3.	Set the MT8801B to the Setup RX parameter mode, set parameters, and press the F12 key.
4.	Set the MT8801B to BER Measure mode.
5.	Set the output level of the MT8801B to -30 dBm, and set the carrier frequency to the measurement frequency.
6.	Set the modulation of the MT8801B to ON.
7.	Connect the RF output of the MT8801B to the RF input of the MS8604A.
8.	Operate the MS8604A to measure the modulation accuracy.

Notes: • For how to operate the MS8604A, refer to the MS8604A Operation Manual.
 • Option 15 (for GMSK) is required for the MS8604A.

5.3.7 Example of performance test result entry sheet

This paragraph gives an example of sheets used to summarize the results of a performance test on the MT8801B Radio Communication Analyzer.

Use a copy of this sheet for the performance test.

1. Reference oscillator frequency stability

Aging rate

Measurement item	Measured value	Measurement uncertainty
Reference oscillator frequency after 24-hour operation (F1) [MHz]		Frequency standard accuracy $\pm 10^{-10}$
Reference oscillator frequency after 48-hour operation (F2) [MHz]		
Difference between reference oscillator frequencies (F2 - F1) [MHz]		
Frequency stability = $(F2 - F1)/F1 \times 10^6$ [ppm]		

Temperature stability

Measurement item	Measured value	Measurement uncertainty
Reference oscillator frequency at ambient temperature of 25°C (F25) [MHz]		Frequency standard accuracy $\pm 10^{-10}$
Reference oscillator frequency at ambient temperature of 50°C (F50) [MHz]		
Reference oscillator frequency at ambient temperature of 0°C (F0) [MHz]		
Difference between reference oscillator frequencies (F50 - F25) [MHz]		
Frequency stability = $(F50 - F25)/F25 \times 10^6$ [ppm]		
Difference between crystal oscillator frequencies (F0 - F25) [MHz]		
Frequency stability = $(F0 - F25)/F25 \times 10^6$ [ppm]		

SECTION 5 PERFORMANCE TESTS

2. Frequency/modulation measurement accuracy

Frequency [MHz]	Carrier Frequency Error				Residue Phase Error					
	Frequency measurement accuracy [kHz]				RMS Phase Error (degree)			Peak Phase Error (degree)		
	Minimum	Actual	Maximum	Measurement uncertainty	Minimum	Actual	Maximum	Minimum	Actual	Maximum
10.0	-0.010	_____	+0.01	±0.000*1	0.00	_____	0.50	0.00	_____	2.00
100.0	-0.010	_____	+0.01	±0.000*1	0.00	_____	0.50	0.00	_____	2.00
1000.0	-0.010	_____	+0.01	±0.000*1	0.00	_____	0.50	0.00	_____	2.00
2000.0	-0.010	_____	+0.01	±0.000*1	0.00	_____	0.50	0.00	_____	2.00
3000.0	-0.010	_____	+0.01	±0.000*1	0.00	_____	0.50	0.00	_____	2.00

*1 Since the measurement-system synchronization is established by the 10 MHz standard signal, the measurement uncertainty is ±0.000 kHz.

3. Transmission power measurement accuracy

Actual power meter reading (dBm)	MT8801B TX power measured value (dBm) on Power Meter screen	MT8801B TX power measured value (dBm) on RF Power screen	Measurement uncertainty (dB)
			±0.15

60 to +40 dBm ±10% @ -10 to +40 ±10%

4. Signal-generator frequency accuracy

Carrier frequency (F1) [MHz]	Carrier frequency measured value (F2) [MHz]	(F2-F1) [Hz]	Measurement uncertainty (Hz)
10.000 000	_____	_____	±0.001

5. Signal-generator output level accuracy

Frequency [MHz]	0.3	1.0	3.0	10.0	30.0	100	300	1000	1500	2000	3000
Output level measured value (dBm)											
Deviation from set level (dB)											
Measurement uncertainty (dB)	± 0.18	± 0.18	± 0.18	± 0.18	± 0.18	± 0.18	± 0.18	± 0.18	± 0.18	± 0.18	± 0.18

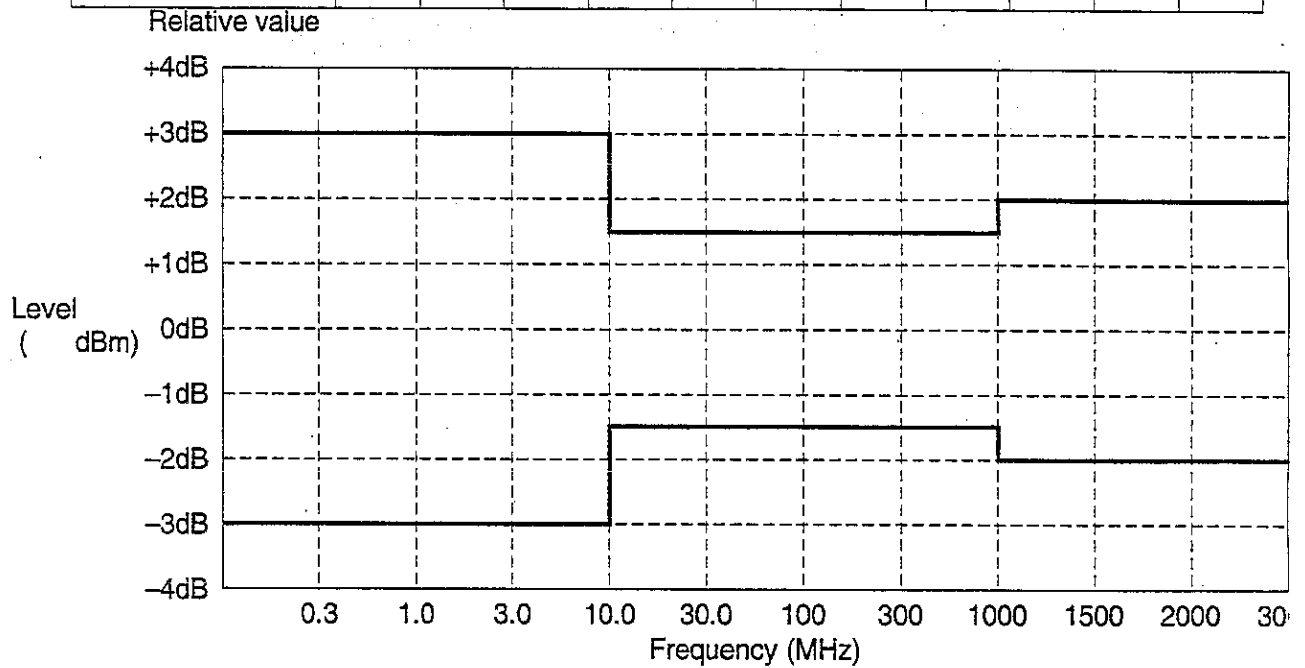

6. Signal-generator modulation accuracy

Frequency (MHz)	10.0	30.0	100	300	1000	1500	2000	3000
Phase error (degrees rms)								
Measurement uncertainty (dB)	0.5	0.5	0.5	0.5	0.5	0.5	0.5	0.5



SECTION 6 CALIBRATION

This section describes the measuring instruments required to calibrate the MT8801B, and the setup and calibration method for these instruments.

TABLE OF CONTENTS

6.1 Calibration Requirements	6-3
6.2 Equipment Required for Calibration	6-3
6.3 Calibration	6-4
6.3.1 Calibrating the reference crystal oscillator	6-4
(1) Specifications	6-4
(2) Instruments required for calibration	6-4
(3) Setup	6-4
(4) Calibration procedure	6-5



6.1 Calibration Requirements

Calibration is done to help maintain the MT8801B's performance.

Calibration should be performed periodically even if the MT8801B is operating normally.

We recommend that the MT8801B be calibrated once or twice a year.

Contact the Service Department of Anritsu Corporation if the MT8801B fails to meet the specifications during calibration.

6.2 Equipment Required for Calibration

The table below shows the equipment required to calibrate each item.

Table 6.1 Equipment Required for Calibration

Recommended equipment	Required performance †	Calibration item
Frequency counter (MF1603A)	<ul style="list-style-type: none"> • 100 KHz to 3 GHz • Resolution: 1 Hz • External reference input: 10 MHz 	Frequency accuracy of reference crystal oscillator
Frequency standard	Standard radio-wave receiver or equipment having equivalent function (accuracy better than 1×10^{-9})	Frequency accuracy of reference crystal oscillator

† Extracts part of performance which can cover the measurement range of the test item.

6.3 Calibration

Do not start the performance tests until the MT8801B and measuring instruments have warmed up for at least 24 hours and they have stabilized completely. To obtain the best measurement accuracy, do the calibration at room temperature. Keep AC power voltage fluctuations, noise, vibration, dust, humidity, and any other factors which can affect results to a minimum.

6.3.1 Calibrating the reference crystal oscillator

The stability of the MT8801B reference crystal oscillator is $\pm 2 \times 10^{-8}$ /day. Calibrate the frequency of the reference crystal oscillator by using a reference signal generator generating a reference signal that is either locked to a standard wave or to the sub-carrier of a TV broadcast on a color TV (the sub-carrier will be locked to a rubidium atomic standard).

(1) Specifications

Reference oscillator	Frequency	Aging rate	Temperature characteristics
Standard type (after 24-hour operation)	10MHz	2×10^{-8} /day	$\pm 5 \times 10^{-8}$ (0°C to 50°C)

(2) Instruments required for calibration

- Frequency counter: 10 MHz external reference input, resolution: 1 Hz
- Frequency standard: Standard radio-wave receiver or equipment having equivalent function (accuracy better than 1×10^{-9})

(3) Setup

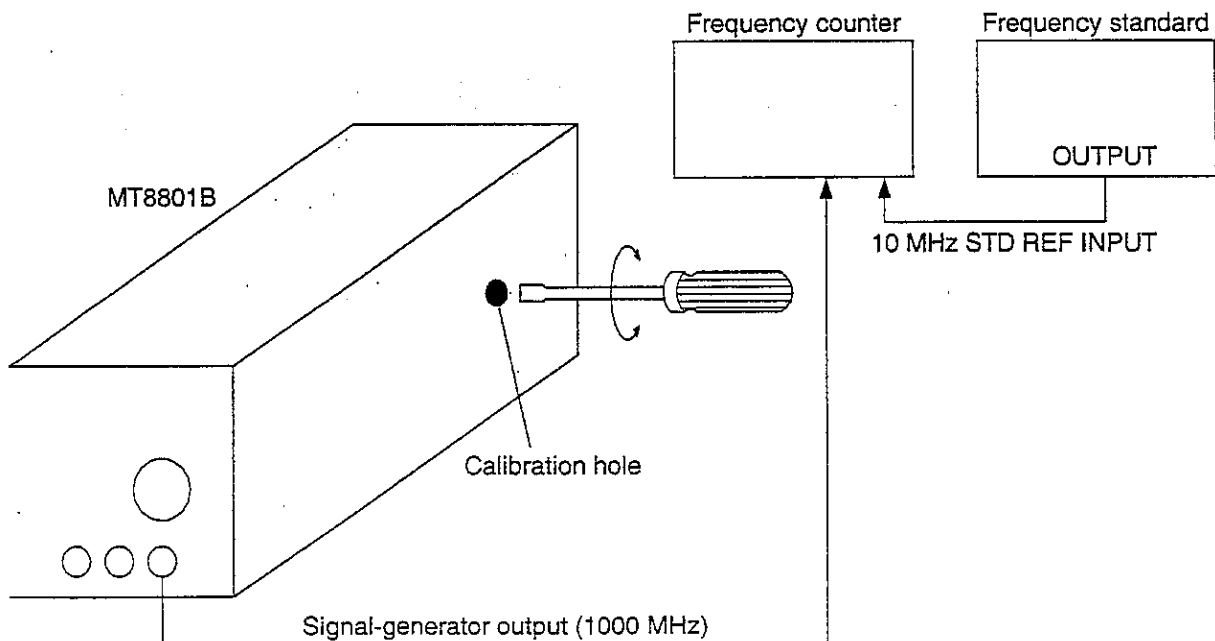

(4) Calibration procedure

Step	Procedure
1.	Setup the equipment as shown in the figure above. The ambient temperature must be $23^{\circ}\text{C} \pm 5^{\circ}\text{C}$.
2.	Set the Power switch on the rear panel to On and the Power switch on the front panel to the Standby position. Then, allow the MT8801B reference crystal oscillator to warm-up for 24 hours.
3.	Set the Power switch on the MT8801B front panel to On.
4.	Apply the standard frequency signal to the external reference input of the frequency counter.
5.	Set the frequency of the signal generator of the MT8801B to 1 000.000 000 MHz, the level to -28 dBm, and the modulation to off.
6.	Adjust the calibration trimmer of the crystal oscillator so that the frequency-counter reading is 1 000.000 000 MHz ± 10 Hz.

SECTION 7

STORAGE AND TRANSPORTATION

This section describes the long-term storage, repacking, and transportation of the MT8801B and the regular maintenance procedures.

TABLE OF CONTENTS

7.1	Cleaning the Cabinet	7-3
7.2	Storage Precautions	7-3
7.2.1	Precautions before storage	7-3
7.2.2	Recommended storage conditions	7-3
7.3	Repacking and Transportation	7-4
7.3.1	Repacking	7-4
7.3.2	Transportation	7-4

7.1 Cleaning the Cabinet

Always turn the MT8801B power switch OFF and disconnect the power plug from the AC power inlet before cleaning the cabinet. To clean the external cabinet:

- Use a soft, dry cloth.
- Use a cloth moistened with diluted neutral cleaning liquid if the instrument is very dirty or before long-term storage. Then, use a soft, dry cloth to wipe the instrument dry.
- If loose screws are found, tighten them with the appropriate tools.

CAUTION

Never use benzine, thinner, or alcohol to clean the cabinet; these chemicals may damage the coating or cause deformation or discoloration.

7.2 Storage Precautions

This paragraph describes the procedures for long-term storage of the MT8801B.

7.2.1 Precautions before storage

- (1) Before storage, wipe dust, finger-marks, and other contaminants off the MT8801B.
- (2) Avoid storing the MT8801B where it may be exposed to:
 - 1) Direct sunlight or high dust levels.
 - 2) High humidity.
 - 3) Active gasses or acid.
 - 4) The following temperatures or humidity:
 - Temperature: > 60 °C, < -20 °C
 - Humidity: ≥ 90%

7.2.2 Recommended storage conditions

The recommended storage conditions are as follows:

- Temperature: 0 to 30 °C
- Humidity: 40% to 80%
- Stable temperature and humidity over a 24-hour period.

7.3 Repacking and Transportation

Take the following precautions if the MT8801B must be returned to Anritsu Corporation for servicing.

7.3.1 Repacking

Use the original packing materials. If the MT8801B is packed in other materials, observe the following packing procedure:

- (1) Wrap the MT8801B in a plastic sheet or similar material.
- (2) Use a cardboard box, wooden box, or aluminum case which allows shock-absorbing material to be inserted on all sides of the MT8801B.
- (3) Use enough shock-absorbing material to protect the MT8801B during transportation and to prevent it from moving in the container.
- (4) Secure the container with packing straps, adhesive tape, or bands.

7.3.2 Transportation

Do not subject the MT8801B to severe vibration during transport. Also, transport under the storage conditions recommended in paragraph 7.2.

APPENDIXES

TABLE OF CONTENTS

APPENDIX A SCREEN AND FUNCTION KEY TRANSITION DIAGRAMS A-1

3

0

1

APPENDIX A SCREEN AND FUNCTION KEY TRANSITION DIAGRAMS

This appendix gives the screen and function-keys transition diagrams.

[Screen transitions] See Paragraph 3.2.

- On any type of screen, the main menu shown below can be displayed by turning the [Main Func On Off] (F6) key to On. When main function keys F1 to F5 and Next Menu key [◀] are used to select a main menu item, the screen transits to the corresponding screen or key menu.

Note: Change Color is a function key menu, so there is no corresponding screen.

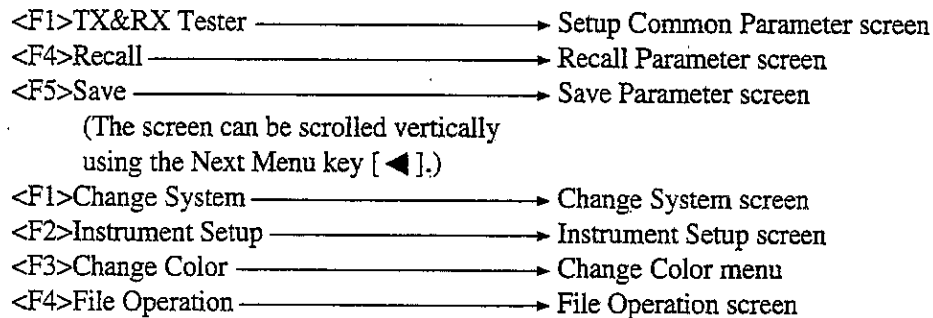

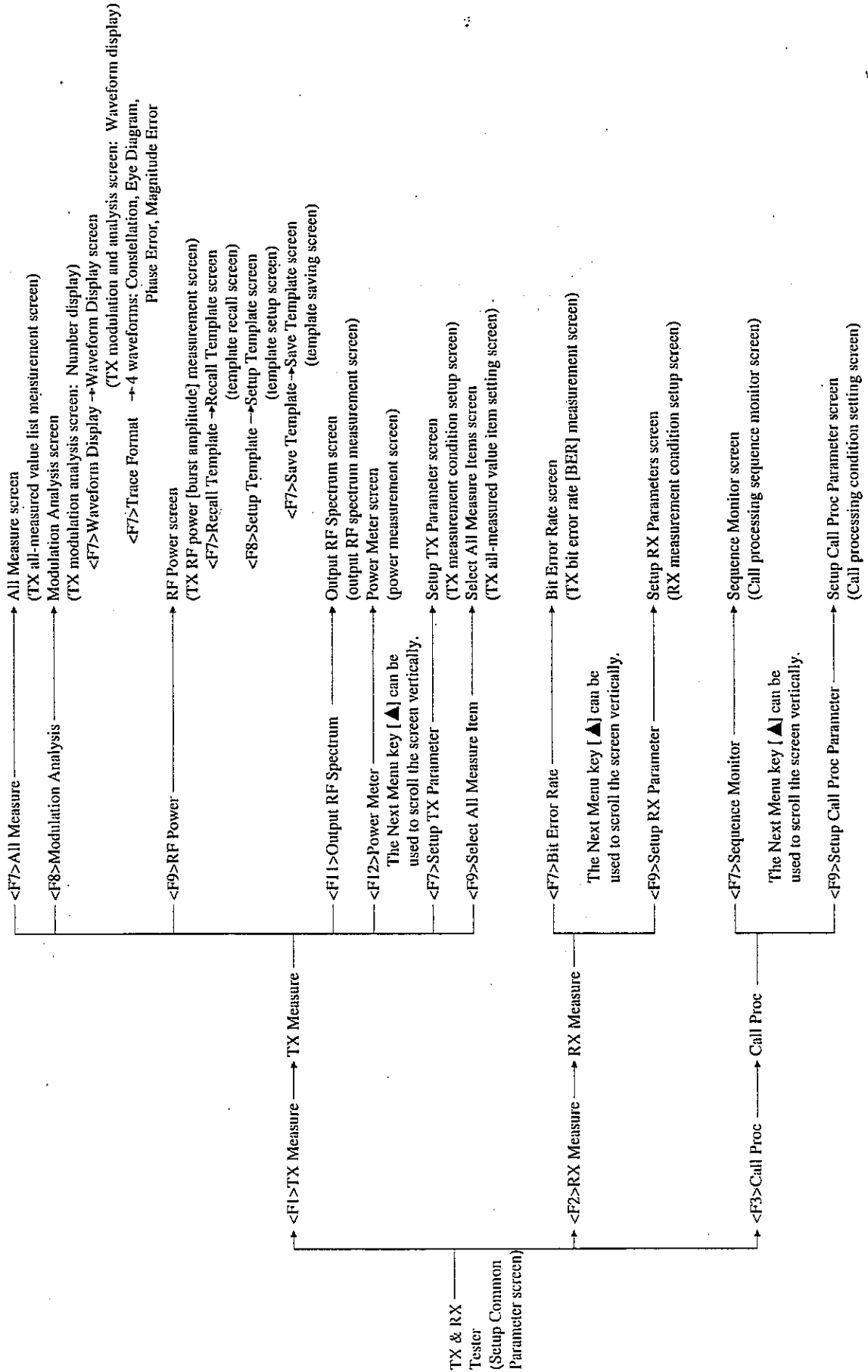

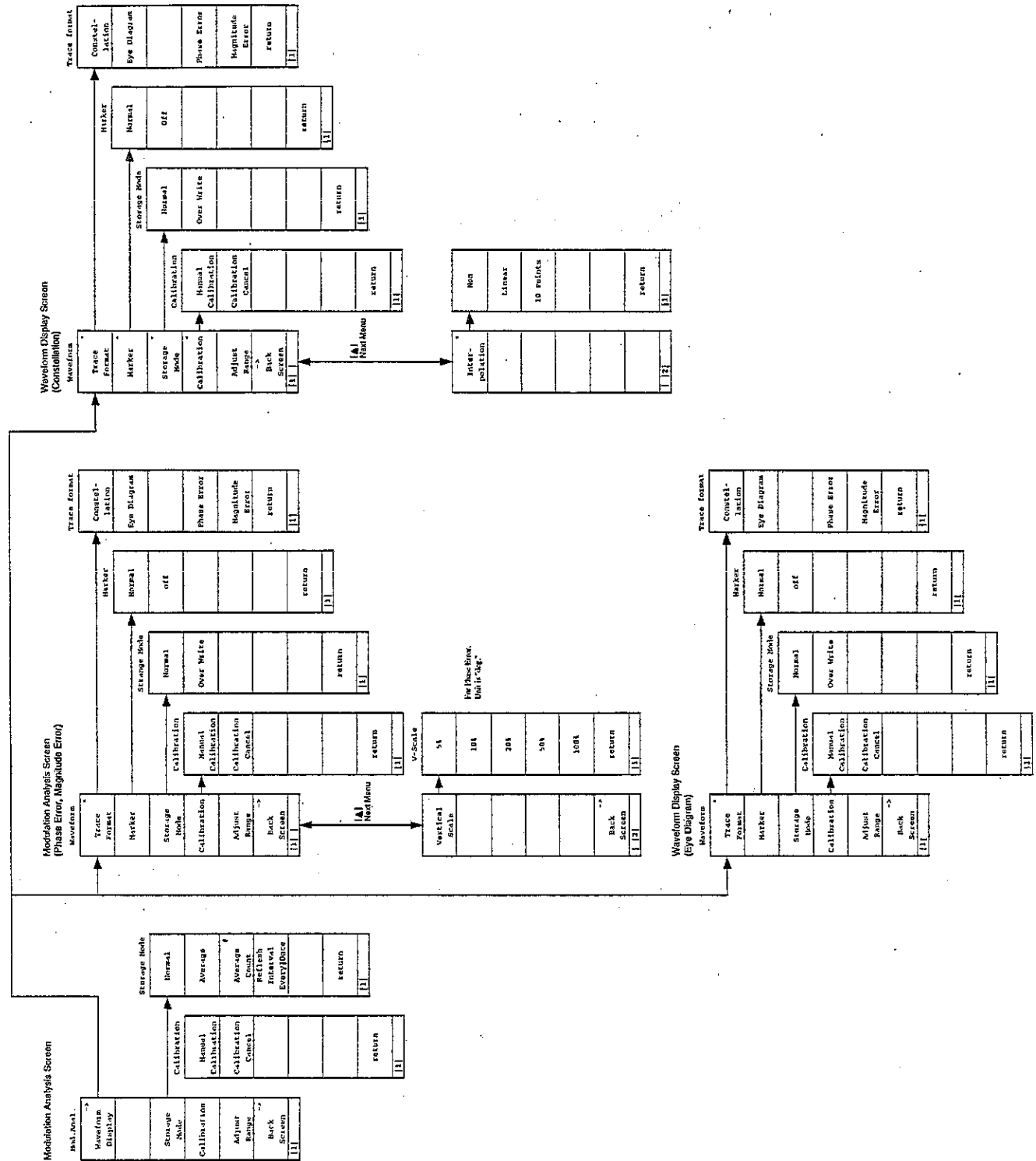

Power Meter screen

Set Relative
Range Up
Range Down
Adjust Range
Zero Set
Back Screen
11

RF Power screen

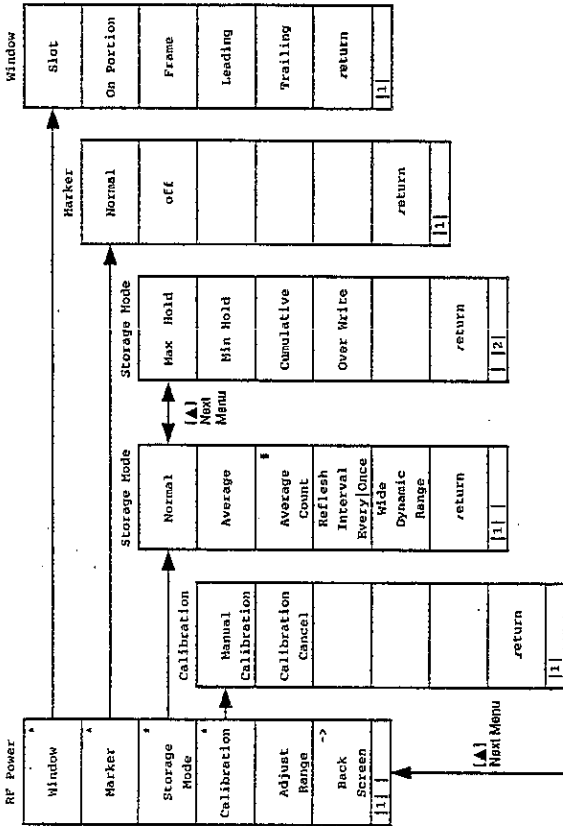

Recall Template screen

Recall Temp.
Display Dir.
File No.
Standard
return
11

Setup Template screen

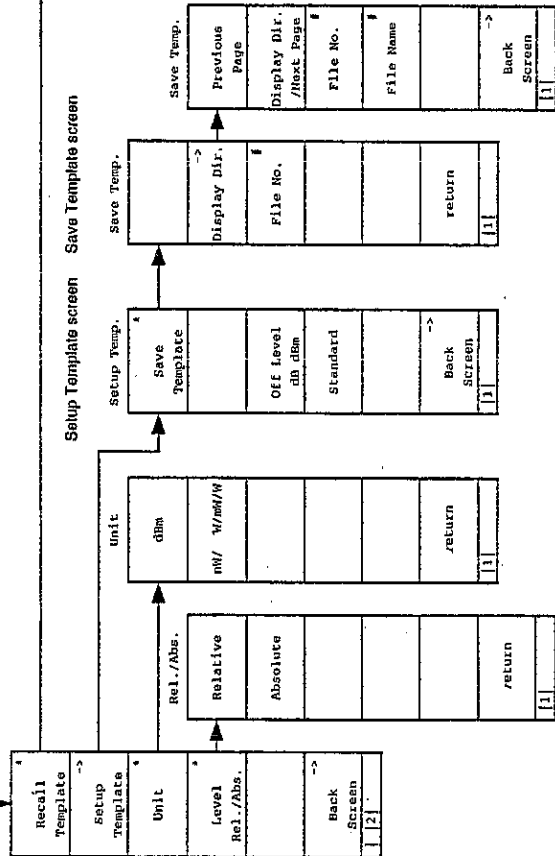

Recall Template screen

Recall Temp.
Display Dir.
File No.
Standard
return
11

Output RF Spectrum screen

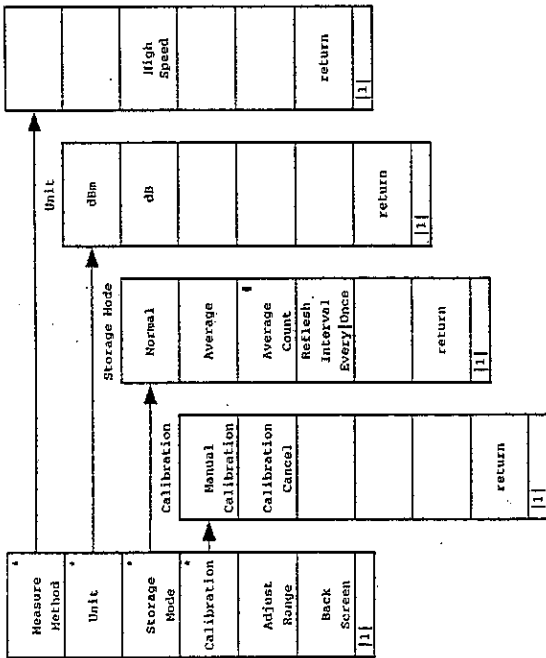

Bit Error Rate screen

When <F1> Measure is selected

Start/Stop
FER Sample
CIB Sample
CII Sample
->
Back Screen
1

When <F2> Frequency is selected

Incremental
Step Value
Relative On Off
Channel
->
Back Screen
1

TX All Measure screen

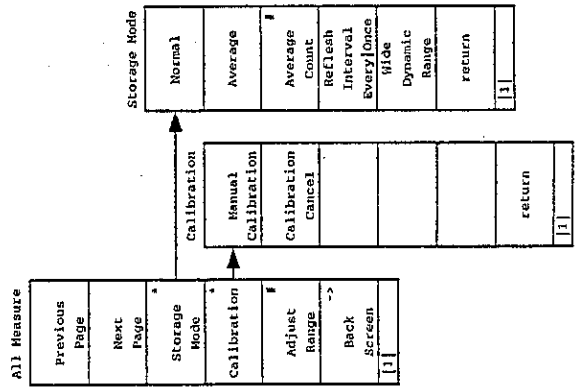

Select All Measure Item screen

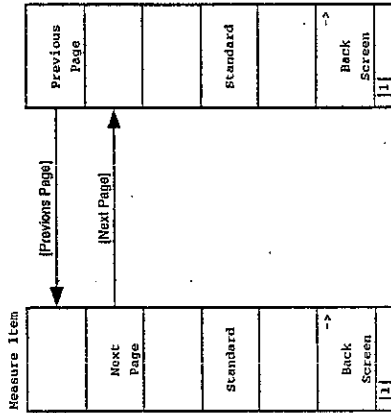

When <F3> Level is selected

Incremental
Step Value
Relative On Off
Continuous On Off
Tx Reference Level
HS Power Level
->
Back Screen
1

[▲] Next Menu

