

MS8604A
Digital Mobile Radio
Transmitter Tester
Operation Manual
Vol. 1

(Panel Operation)

Third Edition

Measuring Instruments Division
Measurement Group

ANRITSU CORPORATION

JAN.
1995

M-W0682AE-3.0

MS8604A Digital Mobile Radio
Transmitter Tester
Operation Manual
Vol. 1
(Panel Operation)

December 1993 (First Edition)
October 1994 (Third Edition)

Copyright © 1994 by Anritsu Corporation

All rights reserved. No part of this manual may be reproduced
without the prior written permission of Anritsu Corporation.

The contents of this manual may be changed without prior notice.

Printed in Japan

WARNING

- *The protective earth terminal of this instrument must be connected to ground. The three-core power cord supplied with the instrument can be plugged into a grounded two pole AC outlet. If no grounded two pole AC outlet is available, the ground pin of the power cord or the earth terminal on the rear panel must be connected to ground before supplying the power to the instrument. Failure to do so could cause dangerous or possibly fatal electric shocks.*
- *Replacing fuses with the power cord still plugged into an AC outlet could also cause electric shocks.*
- *Supplemental explanation about WARNING on the rear panel*

WARNING 

NO OPERATOR SERVICE-
ABLE PARTS INSIDE.
REFER SERVICING TO
QUALIFIED PERSONNEL.

} *A supplemental explanation about the WARNING labeled on the rear panel is given in the following:*

Disassembly, adjustment, maintenance, or other access inside this instrument by unqualified personnel should be avoided. Maintenance of this instrument should be performed only by Anritsu trained service personnel who are familiar with the risks involved of fire and electric shock. Potentially lethal voltages existing inside this instrument, if contacted accidentally, may result in personal injury or death, or in the possibility of damage to precision components.

■ SAFETY CONSIDERATIONS:

Anritsu uses the following labels to identify safety precautions which should be followed to prevent personal injury or product damage. Please familiarize yourself with them before operating this product.

Labels used in this manual:

WARNING : Indicates that the procedure could result in personal injury if not correctly performed. Do not proceed before you fully understand the explanation given with this symbol and meet the required conditions.

CAUTION : Indicates that the operating procedure could result in damage to the product if not correctly performed. Do not proceed before you fully understand the explanation given with this symbol and meet the required conditions.

Note : Indicates that information helpful in understanding the operation of the product is about to be presented.

Labels or symbols used on/in the product:



: This international caution symbol indicates that the operator should refer to the operation manual before beginning a procedure.



: This symbol indicates an earth (ground) terminal. The product should be grounded via the earth terminal if a three prong power cord is not used.

CERTIFICATION

ANRITSU CORPORATION certifies that this instrument has been thoroughly tested and inspected, and found to meet published specifications prior to shipping.

Anritsu further certifies that its calibration measurements are based on the Japanese Electrotechnical Laboratory and Radio Research Laboratory standards.

WARRANTY

All parts of this product are warranted by Anritsu Corporation of Japan against defects in material or workmanship for a period of one year from the date of delivery.

In the event of a defect occurring during the warranty period, Anritsu Corporation will repair or replace this product within a reasonable period of time after notification, free-of-charge, provided that: it is returned to Anritsu; has not been misused; has not been damaged by an act of God; and that the user has followed the instructions in the operation manual.

Any unauthorized modification, repair, or attempt to repair, will render this warranty void.

This warranty is effective only for the original purchaser of this product and is not transferable if it is resold.

ALL OTHER EXPRESSED WARRANTIES ARE DISCLAIMED AND ALL IMPLIED WARRANTIES FOR THIS PRODUCT, INCLUDING THE WARRANTIES OF MERCHANTABILITY AND FITNESS FOR A PARTICULAR PURPOSE, ARE LIMITED IN DURATION TO A PERIOD OF ONE YEAR FROM THE DATE OF DELIVERY. IN NO EVENT SHALL ANRITSU CORPORATION BE LIABLE TO THE CUSTOMER FOR ANY DAMAGES, INCLUDING LOST PROFITS, OR OTHER INCIDENTAL OR CONSEQUENTIAL DAMAGES, ARISING OUT OF THE USE OR INABILITY TO USE THIS PRODUCT.

All requests for repair or replacement under this warranty must be made as soon as possible after the defect has been noticed and must be directed to Anritsu Corporation or its representative in your area.

'IBM' is a registered trademark of the IBM Corporation.

'HP' is a registered trademark of the Hewlett-Packard Company.

'MS-DOS' is a registered trademark of the Microsoft Corporation.

'NEC' is a registered trademark of the NEC Corporation.

MEMORY BACK-UP BATTERY REPLACEMENT

The power for memory back-up is supplied by a Poly-carbomonofluoride Lithium Battery. This battery should only be replaced by a battery of the same type; since replacement can only be made by Anritsu, contact the nearest Anritsu representative when replacement is required.

At the end of it's life, the battery should be recycled or disposed properly.

STORAGE MEDIUM

This equipment stores data and programs using Plug-in Memory cards (PMC) and backed-up memories. Data and programs may be lost due to improper use or failure. ANRITSU therefore recommends that you back-up the memory.

ANRITSU CANNOT COMPENSATE FOR ANY MEMORY LOSS.

Please pay careful attention to the following points. Do not remove the IC card and backed-up memory from equipment being accessed.

(PMC)

- Isolate the card from static electricity.
- The back-up battery in the SRAM card has a limited life; replace the battery periodically.

(Backed-up memory)

- Isolate the memory from static electricity.

Note: The battery life is about 7 years. Early battery replacement is recommended.

DISPOSING OF THE PRODUCT

The MS8604A uses chemical compound semiconductor including arsenic.

At the end it's life, the MS8604A should be recycled or disposed properly.

ABOUT THIS MANUAL

(1) Operation manual composition

The MS8604A operation manuals are made up of the following three manuals. Use the manuals matching the usage objective.

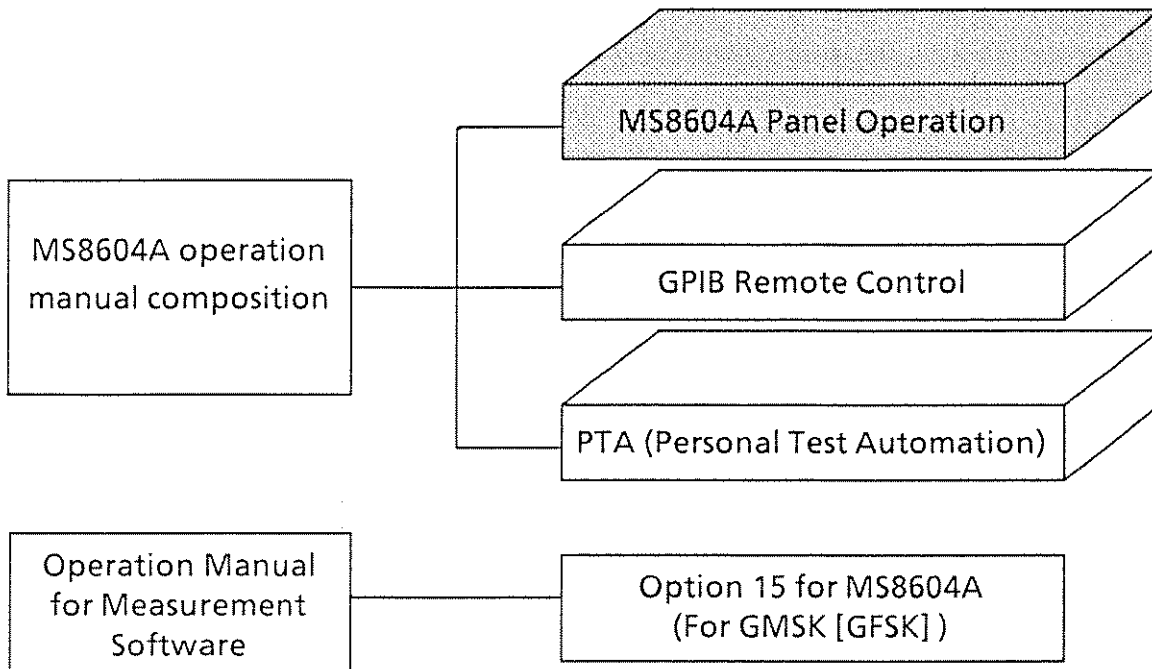

Panel Operation: Outlines the MS8604A and describes its specifications, preparations, panels, manual (local) operation method, storage, transportation, function keys transition diagram, initial values table, and error messages.

GPIB Remote Control: Since the MS8604A is compatible with IEEE488.2, this manual describes GPIB remote control based on IEEE488.2. The descriptions in this manual are based on N₈₈-BASIC programs using an NEC PC9800 Series personal computer for program generation reference.

PTA Personal Test Automation: Describes how to program high-speed control and high-speed operation processing directly connected to the measurement system by high level language PTL. The program is executed by a personal computer built into the MS8604A and is called PTA (Personal Test Automation). Together with GPIB mentioned above, it promotes measurement automation.

(2) Basic Guide to GPIB (sold separately)

A “Basic Guide to GPIB” is sold separately from the operation manuals above.

This guide provides a basic knowledge of GPIB and describes the GPIB control statements written in Anritsu PACKET V computer language.

(Blank)

TABLE OF CONTENTS

SECTION 1	GENERAL	1-1
1.1	General	1-3
1.2	Manual Composition	1-4
1.3	Equipment Configuration	1-5
1.3.1	Standard configuration	1-5
1.3.2	Options	1-5
1.4	Optional Accessories and Peripherals	1-6
1.5	Specifications	1-9
SECTION 2	PREPARATIONS BEFORE USE	2-1
2.1	Installation Site and Environment Conditions	2-3
2.2	Safety Measures	2-4
2.2.1	Power-on	2-4
2.2.2	Maximum reverse power to RF Output connector	2-5
2.3	Preparations before Power-on	2-6
2.3.1	Protective grounding	2-7
2.3.2	Replacing fuse	2-8
2.4	Precautions for Handling Storage Media	2-10
2.4.1	Floppy disks	2-10
2.4.2	Plug-in memory cards (PMC)	2-11
SECTION 3	PANEL LAYOUT AND OVERVIEW OF OPERATION	3-1
3.1	Panel Layout	3-3
3.1.1	Front panel keys and rotary knob	3-3
3.1.2	Front panel connectors	3-6
3.1.3	Rear panel layout	3-7
3.1.4	Panel layout	3-8
3.2	Overview of Operation	3-11
3.2.1	Overview of functions	3-11
3.2.2	Overview of operation	3-12

SECTION 4	OPERATION	4-1
4.1	Turning on the Power	4-3
4.2	Screen Descriptions	4-4
4.2.1	TX Test mode screen	4-4
4.2.2	Spectrum mode screens	4-7
4.3	Transmitter Test --- TX Test Mode	4-8
4.3.1	Preparations	4-8
4.3.2	System standard selection (MODE)	4-11
4.3.3	Parameter setting and measurement item setting (SETUP PARAMETER)	4-12
4.3.4	Modulation analysis (MODULATION ANALYSIS)	4-23
4.3.5	Power measurement (RF POWER)	4-29
4.3.6	Occupied frequency bandwidth measurement (OCCUPIED BANDWIDTH)	4-38
4.3.7	Adjacent channel leakage power measurement (ADJACENT CHANNEL POWER)	4-41
4.3.8	Spurious emissions measurement (SPURIOUS EMISSIONS)	4-45
4.3.9	Power meter (POWER METER)	4-50
4.4	Spectrum Analyzer Function ··· SPECTRUM mode	4-55
4.4.1	Outline of setting	4-55
4.4.2	Frequency domain or time domain selection (TRACE FREQ/TIME)	4-56
4.4.3	Frequency setting	4-58
4.4.4	Automatic tuning (AUTO TUNE)	4-61
4.4.5	Level setting	4-62
4.4.6	Frequency domain display mode and detection mode setting	4-66
4.4.7	Time domain delay time, time span, expansion mode, and display mode setting	4-70
4.4.8	Zone marker sweep, input signal tracking, input signal gate, and sweep trigger signal setting (SWEEP/GATE/TRIG)	4-74
4.4.9	Resolution bandwidth (RBW), video bandwidth (VBW), sweep time (SWT), and RF input attenuator (ATTEN) setting	4-86
4.4.10	Marker setting (MARKER)	4-92
4.4.11	FM modulation signal and external trigger signal waveform monitor (FM/TRIG MONITOR)	4-103
4.4.12	AM/FM demodulated signal sound monitor (SOUND)	4-106
4.4.13	Parameters setting list display (PARAMETER)	4-108
4.4.14	System setting (SYSTEM)	4-110
4.4.15	Calibration (CAL)	4-111

4.5	System Setting (SYSTEM SETUP)	4-113
4.5.1	Overview of setting	4-113
4.5.2	Data file setting	4-113
4.5.3	Alarm tone setting	4-118
4.5.4	RF input connector setting	4-118
4.5.5	GPIB address setting	4-119
4.5.6	RS-232C setting (Option)	4-120
4.6	Save/Recall	4-121
4.7	Copy	4-123
4.8	Initialization	4-124
4.9	GPIB Remote Reset	4-124
4.10	PTA Setting	4-124
4.11	I/Q Input (Option)	4-124

SECTION 5 STORAGE AND TRANSPORTATION 5-1

5.1	Requirement for Performance Tests	5-3
5.2	Instruments Required for Performance Test	5-4
5.3	Performance Test	5-6
5.3.1	Reference oscillator frequency stability	5-6
5.3.2	Center frequency readout accuracy	5-8
5.3.3	Frequency span readout accuracy	5-10
5.3.4	Amplitude scale linearity	5-13
5.3.5	Frequency characteristics	5-16
5.3.6	Reference level accuracy	5-19
5.3.7	Instrument accuracy and zero shift between ranges	5-21
5.3.8	Calibration oscillator output accuracy	5-24
5.3.9	PDC frequency/modulation accuracy	5-26
5.3.10	PDC transmission power accuracy	5-28
5.3.11	PHS frequency/modulation accuracy	5-30
5.3.12	PHS transmission power accuracy	5-32
5.3.13	NADC frequency/modulation accuracy	5-34
5.3.14	NADC transmission power accuracy	5-36

SECTION 6 CALIBRATION 6-1

6.1	Requirement for Calibration	6-3
6.2	Equipment Required for Calibration	6-3
6.3	Calibration	6-4
6.3.1	Calibrating reference-crystal-oscillator frequency	6-4

SECTION 7	STORAGE AND TRANSPORTATION	7-1
7.1	Cleaning Cabinet	7-3
7.2	Storage Precautions	7-3
7.2.1	Precautions before storage	7-3
7.2.2	Recommended storage precautions	7-3
7.3	Repacking and Transportation	7-4
7.3.1	Repacking	7-4
7.3.2	Transportation	7-4
APPENDIX A	SCREENS AND FUNCTIONS KEYS TRANSITION DIAGRAM	A-1
APPENDIX B	INITIAL VALUES TABLES	B-1
APPENDIX C	ERROR MESSAGES	C-1
APPENDIX D	CONNECTION TO UA-455A VIDEO PLOTTER	D-1

SECTION 1

GENERAL

This section outlines the MS8604A Digital Mobile Radio Transmitter Tester and describes the composition of its manual. This section also describes the standard accessories, options and peripherals for expanding its functions, and the instrument specifications.

TABLE OF CONTENTS

1.1	General	1-3
1.2	Manual Composition	1-4
1.3	Equipment Configuration	1-5
1.3.1	Standard configuration	1-5
1.3.2	Options	1-5
1.4	Optional Accessories and Peripherals	1-6
1.5	Specifications	1-9

(Blank)

1.1 General

The MS8604A Digital Mobile Radio Transmitter Tester permits evaluation of the main characteristics of the transmitters used with Japanese and North American digital modulation type mobile and cordless telephones, with one instrument.

The MS8604A covers the 100 Hz to 8.5 GHz frequency range and can measure wideband spurious emissions, as well as evaluate the transmitter RF signal. RF signals up to 10 W (average power of burst signal) can be measured directly. Baseband signals can also be evaluated easily by an I/Q signal input function (option).

RCR and MKK standards measurement and high-speed measurement by DSP (Digital Signal Processing) technology and original algorithms substantially reduce radio equipment manufacturing and inspection time.

PTA, which allows free programming of the test method, is also installed as standard. It is perfect for high-speed measurement of the transmission power, frequency, modulation accuracy, signal transmission rate, rise/fall characteristics, occupied bandwidth, adjacent channel leakage power, carrier-off leakage power, and spurious emissions of digital mobile radio transmitters.

- An High power attenuator (10 W) and power meter, indispensable in transmitter testing, are built-in.
- The main characteristics of a transmitter can be evaluated with one instrument.
- When the measurement item is selected, the results are obtained immediately and operation is extremely easy.
- Adaptable to PDC, PHS, NADC, and digital MCA/GMSK (GFSK) by measurement software. (One system is standard; up to five systems can be equipped by options)
- Modulation accuracy is measured at high speed (1 second or less).
- I/Q signal input (option)
- PTA (Personal Test Automation) is installed as standard.

1.2 Manual Composition

This manual is made up of seven sections and Appendixes A, B, C, and D. Each section is outlined below.

Section	Description
Section 1 General	Introduction, manual composition, composition of standard accessories, optional accessories and peripherals for functions expansion, and specification.
Section 2 Preparations	Work to be performed before using the instrument (before turning on the power).
Section 3 Panel Layout and Overview of Operation	Layout of keys, connectors, indicators, and other parts on the front and rear panels, a description of their functions and an outline of their operation.
Section 4 Operation	Detailed description of manual setting.
Section 5 Performance Test	Measuring instruments, setup, and performance test method required for conducting performance test.
Section 6 Calibration	Measuring instruments, setup, and calibration method required for conducting calibration.
Section 7 Storage and Transportation	Daily maintenance, long-term storage, repacking and transportation.
Appendix A Screens and Function Keys Transition Diagram	Summary of screens and function keys flow at each screen.
Appendix B Initial Value Tables	Summary of initial values when MS8604A initialized by [Preset] key or GPIB command (PRE, INI, IP, *RST).
Appendix C Error Messages	Summary of error messages displayed when an operation or measurement error occurs.
Appendix D Connection to UA-455A Video Plotter	Method of connecting the UA-455A and the UA-455A setting method.

1.3 Equipment Configuration

This paragraph describes the configuration of the MS8604A Digital Mobile Radio Transmitter Tester with standard accessories.

1.3.1 Standard configuration

The table below shows the configuration of the MS8604A with the standard accessories.

Table 1-1 Standard composition

Item	Order No.	Name	Qty.	Remarks
Main instrument		MS8604A digital Mobile Radio Transmitter Tester	1	
Accessories	J0114	50 Ω coaxial cord	1	Approx. 1 m (UG-21D/U · RG-9A/U · UG-21D/U)
		Power sensor	1	MA4601A
		Power sensor connection cord	1	J0370N, 0.5 m
	P0005	Memory card (PMC)	1	32 KB (BS32F1-C-172)
	J0017F	Power cord	1	Approx. 2.5 m
	J0266	Adapter	1	3 poles to 2 poles plug conversion adapter
	F0014	Fuse	1 set	6.3 A 2 pcs (T6.3 A 250 V)
	W0682AE	Operation manual	1 set	Panel operation part/GPIB remote control part/PTA

1.3.2 Options

The table below shows the MS8604A which are sold separately.

Table 1-2 Options

Option No.	Name	Remarks
01	Reference crystal oscillator	Stability : 5×10^{-9} /day
02	RS-232C interface	
03	I/Q input	
11	Software for PDC	Operation Manual
12	Software for PHS	
13	Software for NADC	
15	Software for GSMK	

1.4 Optional Accessories and Peripherals

The following table shows the optional accessories and peripherals for the MS8604A which are all sold separately.

Table 1-3 Optional Accessories (1/2)

Model*/Order No.*	Name*	Remarks
J0127A	Coaxial cord	Approx. 1 m (BNC-P · RG-58A/U · BNC-P)
J0003A	Coaxial cord	Approx. 1 m (SMA-P · special 3D-2W · SMA-P)
J0055	Coaxial adapter	NC-P · BNC-J
J0004	Coaxial adapter	N-P · SMA-J
MP721 <input type="checkbox"/>	Fixed attenuator	DC to 12.4 GHz, 3 to 60 dB, 2 W
J0063	Attenuator for high power	DC to 12.4 GHz, 30 dB, 10 W
J0078	Attenuator for high power	DC to 18 GHz, 20 dB, 10 W
J0079	Attenuator for high power	DC to 8 GHz, 30 dB, 25 W
J0395	Attenuator for high power	DC to 8 GHz, 30 dB, 30 W
J0007	GPIB connection cable	Approx. 1 m (408JE-101)
J0008	GPIB connection cable	Approx. 2 m (408JE-102)
P0005	Memory card (32 K bytes)	BS32F1-C-172 Battery life: approx. 5 years
P0006	Memory card (64 K bytes)	BS64F1-C-173 Battery life: approx. 5 years
P0007	Memory card (128 K bytes)	BS128F1-C-174 Battery life: approx. 4.3 years
P0008	Memory card (256 K bytes)	BS256F1-C-1175 Battery life: approx. 2.2 years
P0009	Memory card (512 K bytes)	BS512F1-C-1176 Battery life: approx. 1.1 years
MP614A	50 Ω to 75 Ω impedance transformer	N-type connector, 10 to 1200 MHz, 1 W
MB009	50 Ω to 75 Ω impedance transformer	N-type connector, DC to 2 GHz, 0.5 W Insertion loss 6.2 dB
MN1607A	Coaxial switch	DC to 3 GHz, 50 Ω (externally controllable)
MP59B	Coaxial switch	N-type connector, DC to 3 GHz, 100 W
MP640A	Branch	DC to 1.7 GHz, 40 dB, 16 W
MP654A	Coupler	0.8 to 3 GHz, 30 dB, 50 W
MP655A	Coupler	3 to 4.4 GHz, 30 dB, 50 W

*Please specify the model/order number, name, and quantity when ordering.

Table 1-3 Optional Accessories (2/2)

Model*/Order No.*	Name*	Remarks
MP520A	CM directional coupler	25 to 500 MHz, 75 Ω , NC-J, 200 W
MP520B	CM directional coupler	25 to 1000 MHz, 75 Ω , NC-J, 200 W
MP520C	CM directional coupler	25 to 500 MHz, 50 Ω , 200 W
MP520D	CM directional coupler	100 to 1700 MHz, 50 Ω , 200 W
MR63J	Reflection bridge	5 MHz to 2 GHz, 50 Ω , N-P
MP526A	High-pass filter	For 60 MHz band, + 10 dBm input max
MP526B	High-pass filter	For 150 MHz band, + 10 dBm input max
MP526C	High-pass filter	For 250 MHz band, + 10 dBm input max
MP526D	High-pass filter	For 400 MHz band, + 10 dBm input max
MP526G	High-pass filter	For 27 MHz band, + 10 dBm input max
MODEL562	DC block	Recommended product, NARDA product 10 MHz to 12.4 GHz
MA4001A	Range calibrator	
B0329D	Protective cover	
B0331D	Front handle	2 pcs/pair
B0332	Connection panel	
B0333D	Rack mount kit	
B0334D	Carrying case (hard type)	With protective cover and caster

*Please specify the model/order number, name, and quantity when ordering.

Table 1-4 Peripherals

Model*/Order No.*	Name*	Remarks
MN63A	Programmable attenuator	DC to 2 GHz, N, 0.25 W
MN64B	Programmable attenuator	DC to 1 GHz, BNC, 0.25 W
MN65A	Programmable attenuator	DC to 6 GHz, N, 1 W
MN72A	Programmable attenuator	DC to 18 GHz, SMA, 1 W
MD6420A	Data transmission analyzer	50 bps to 10 Mbps
ME2627A/B	Digital modulation waveform analyzer	10 MHz to 2.7 GHz
MS2602A	Spectrum analyzer	100 Hz to 8.5 GHz
MG3633A	Synthesized signal generator	10 kHz to 2.7 GHz
MG3670A	Digital modulation signal generator	300 kHz to 2.1 GHz
G0044	PTA keyboard	
UA-455A	Video plotter	
Z0047	Paper for video plotter	5 rolls/set
FP-850	Printer	Epson
MC8104A	Data storage unit	
MH648A	Pre-amplifier	0.1 to 1200 MHz, 30 dB
MA8610A	Pre-amplifier	9 kHz to 2.2 GHz, 20 dB
MP635A	Log-periodic antenna	80 to 1000 MHz
MB19A	Antenna tripod	With pole, for MP635A/MP636A
MP666A	Log-periodic antenna	200 to 2000 MHz
MB18B	Antenna pole	For MP666A
MB9A	Antenna tripod	For MP666A

*Please specify the model/order number, name, and quantity when ordering.

1.5 Specifications

The MS8604A specifications are listed in the following table.

Table 1-5 MS8604A Specifications (1/18)

1	GENERAL	
1.1	Frequency range	100 Hz to 8.5 GHz
1.2	Max. input level	+ 40 dBm (10 W) Continuous wave, Average power
1.3	Reference Oscillator	[]: Option
	(1) Frequency	10 MHz
	(2) Starting characteristic	$\leq 5 \times 10^{-8}$ [$\leq 2 \times 10^{-8}$, after 30 mins of warm-up] Referred to at freq. after 24 hours of warm-up, after 10 mins of warm-up
	(3) Aging rate	$\leq 2 \times 10^{-8}$ /day [$\leq 5 \times 10^{-9}$ /day] $\leq 1 \times 10^{-7}$ /year [$\leq 5 \times 10^{-8}$ /year] Referred to at freq. after 24 hours of warm-up
	(4) Temperature characteristic	5×10^{-8} (0 to 50°C) [3×10^{-8}] Referred to freq. at 25°C

Table 1-5 MS8604A Specifications (2/18)

2	SPECTRUM ANALYZER									
2.1	Frequency									
2.1.1	Frequency range	100 Hz to 8.5 GHz								
	(1) Frequency band configuration	<table border="1"> <thead> <tr> <th>Band</th> <th>Frequency</th> </tr> </thead> <tbody> <tr> <td>0</td> <td>0 to 2 GHz</td> </tr> <tr> <td>1-</td> <td>1.7 to 7.5 GHz</td> </tr> <tr> <td>1+</td> <td>6.5 to 8.5 GHz</td> </tr> </tbody> </table>	Band	Frequency	0	0 to 2 GHz	1-	1.7 to 7.5 GHz	1+	6.5 to 8.5 GHz
Band	Frequency									
0	0 to 2 GHz									
1-	1.7 to 7.5 GHz									
1+	6.5 to 8.5 GHz									
	(2) Preselector range	1.7 GHz to 8.5 GHz (Bands: 1- / 1+)								
2.1.2	Frequency setting									
	(1) Setting range	100 Hz to 8.5 GHz								
	(2) Setting resolution	1 Hz								
2.1.3	Display accuracy	\pm (Displayed freq. \times Reference freq. accuracy + Span \times Span accuracy)								
2.1.4	Span									
	(1) Setting range	0 Hz, 100 Hz to 8.5 GHz								
	(2) Accuracy	$\pm 2.5\%$ (Span ≥ 1 kHz) $\pm 5\%$ (100 Hz \leq Span < 1 kHz)								
2.1.5	Resolution bandwidth									
	(1) Setting range	10 Hz to 3 MHz (3 dB) 1-3 sequence								
	(2) Accuracy	$\pm 20\%$								
	(3) Selectivity (60/3 dB)	$\leq 15 : 1$ (100 kHz to 3 MHz) $\leq 12 : 1$ (10 Hz to 30 kHz)								
2.1.6	Video bandwidth	1 Hz to 3 MHz, Off, and 1-3 sequence								
2.1.7	Signal purity									
	(1) Sideband noise	Frequency: 1 MHz to 4 GHz ≤ -100 dBc/Hz (10 kHz offset) ≤ -115 dBc/Hz (50 kHz offset) ≤ -120 dBc/Hz (100 kHz offset)								

Table 1-5 MS8604A Specifications (3/18)

2.2	Amplitude	
2.2.1	Level measurement	
	(1) Level measuring range	Average noise level to +40 dBm
	(2) Average noise level	≤ -112 dBm (10 MHz to 8.5 GHz, RBW 10 Hz, VBW 1 kHz, Input att. setting 20 dB)
	(3) Residual response	≤ -75 dBm (1 MHz to 8.5 GHz, Input att. setting 20 dB)
2.2.2	Reference level	
	(1) Setting range	-80 to +40 dBm
	(2) Accuracy	After calibration and at freq. 100 MHz, Span ≤ 2 MHz, and in Auto mode of Input att, RBW, VBW and Sweep time settings ± 0.5 dB (-30 to +20 dBm) ± 0.75 dB (-40 to -30 dBm, +20 to +40 dBm) ± 1.5 dB (-60 to -40 dBm)
	(3) RBW switching error	after calibration ± 0.3 dB (RBW ≤ 300 kHz) ± 0.7 dB (RBW ≥ 1 MHz)
	(4) LOG/LIN scale switching error	after calibration ± 0.3 dB
	(5) Input attenuator	
	Setting range	20 to 75 dB in 5 dB steps
	Switching error	± 0.3 dB (at freq. 100 MHz, Input att. 30 dB)
2.2.3	Frequency characteristic	± 0.5 dB (100 MHz to 2 GHz, band 0) ± 1 dB (1.7 to 8.5 GHz, bands 1 - /1 +) Referred to at 100 MHz, input att. 30 dB, temperature 18° to 28°C (after tuning of Preselector at bands 1 - /1 +)
2.2.4	Linearity	after calibration LOG : ± 0.3 dB (0 to -20 dB, RBW ≤ 1 MHz) ± 1 dB (0 to -60 dB, RBW ≤ 100 kHz) ± 1.5 dB (0 to -80 dB, RBW ≤ 10 kHz) LIN : $\pm 5\%$ (to a reference level)

Table 1-5 MS8604A Specifications (4/18)

2.2.5	Dynamic range (1) 2nd harmonics distortion (2) Two-signal third-order distortion	≤ -70 dBc (5 to 800 MHz, band 0, mixer input level - 30 dBm) ≤ -80 dBc (800 to 850 MHz, band 0, mixer input level - 30 dBm) ≤ -90 dBc (850 MHz to 2.1 GHz, band 1 -, mixer input level - 10 dBm) Frequency difference between two signals ≥ 50 kHz, mixer input level - 30 dBm ≤ -70 dBc (10 to 50 MHz) ≤ -85 dBc (50 MHz to 2.1 GHz)
2.2.6	Spurious (1) Image response (2) Multi-response	≤ -70 dBc Bands 1 - /1 + ≤ -70 dBc
2.2.7	Sweep (1) Sweep time Setting range Accuracy (2) Sweep mode (3) Trigger switch (4) Trigger source (5) Gate mode Setting Range	20 ms to 1000 s (Trace-Freq., Data points: Normal) 50 ms to 1000 s at other conditions $\pm 10\%$ (20 ms to 200 s) $\pm 15\%$ (200 to 1000 s) CONTINUOUS, SINGLE FREE RUN, TRIGGERED VIDEO, LINE, EXT (± 10 V), EXT (TTL) OFF, RANDOM sweep mode GATE DELAY : 0 to 65.5 ms (1 μ s step) GATE LENGTH : 20 μ s to 65.5 ms (1 μ s step, GATE END : INT) GATE END : INT/EXT

Table 1-5 MS8604A Specifications (5/18)

2.2.8	<p>Time axis waveform display</p> <p>(1) Sweep time Setting range</p> <p>(2) Delay time Setting range</p> <p>(3) Amplitude display resolution</p>	<p>50, 100 to 900 μs (Data point: NORMAL, One most significant digit can be set)</p> <p>1 ms to 1000 s (Data point: NORMAL, Two most significant digits can be set)</p> <p>100, 200 to 800 μs (Data point: DOUBLE, One most digit can be set in even number)</p> <p>1 ms to 1000 s (Data point: DOUBLE, Two most significant digits can be set in even number)</p> <p>Pre-trigger : - time span to 0 s (in 1 point steps)</p> <p>Post trigger : 0 s to 65.5 ms (in 1 μs steps)</p> <p>50 μs to 49 ms, 10 bits (0.1% of Full scale)</p> <p>50 ms to 1000 s, 14 bits (0.01% of Full scale)</p>
2.2.9	Detection mode	POS PEAK, SAMPLE, NEG PEAK
2.2.10	Number of data points	<p>NORMAL : 501 points</p> <p>DOUBLE : 1002 points</p>
2.2.11	AM/FM demodulation	Demodulated waveform display and monitor of a demodulated audio signal with a built-in speaker
2.2.12	<p>Auxiliary inputs/outputs terminal</p> <p>(1) IF output 21.4 MHz</p> <p>(2) Y output</p> <p>(3) External trigger input Input 1 : Input 2 :</p>	<p>- 10 dBm \pm 2 dB (an the top of the screen display, with the output terminated with a 50 Ω terminator), BNC connector</p> <p>0 to 0.5 V \pm 0.1 V (at range between the top and the bottom lines of the screen, LOG 10 dB/div, LIN: 10 %/div, 100 MHz and with the output terminated with a 75 Ω terminator), BNC connector</p> <p>Max. \pm 10 V (0.1 V steps, Rising/falling edge, selectable and Pulse width 10 μs), BNC connector</p> <p>TTL level (Rising/falling edges, selectable and Pulse width 10 μs), BNC connector</p>

Table 1-5 MS8604A Specifications (6/18)

3	POWER METER	
3.1	Frequency range	100 kHz to 5.5 GHz
3.2	Level range	- 20 to + 20 dBm
3.3	Instrument accuracy	$\pm 0.5\%$
3.4	Zero set	$\pm 0.5\%$ of Full scale at the most sensitive range (100 μ W range)
3.5	Zero shift between ranges	$\pm 0.2\%$ of Full scale after zero setting at the most sensitive range
3.6	Calibration oscillator	Frequency : 50 MHz Output : 1.00 mW Accuracy : $\pm 1.2\%$
3.7	Applicable sensor	MA4601A

Table 1-5 MS8604A Specifications (7/18)

4	TRANSMITTER MEASUREMENT	
4.1	Personal Digital Cellular (PDC)	Option 11 Specifications below are guaranteed after pressing a key for optimizing an internal level.
4.1.1	Modulation/freq. measurement	
	(1) Frequency range	400 kHz to 2.1 GHz
	(2) Input level range	-10 to +40 dBm (Average power of a burst signal)*1 *1 Down to a level by 20 dB lower than above level can be measured when using a low-power input terminal.
	(3) Carrier freq. Accuracy	\pm (Accuracy of the reference oscillator + 1 Hz)
	(4) Modulation precision Accuracy	\pm (2% of an indicated value + 0.5%)
	(5) Origin offset Accuracy	\pm 0.5 dB (to a signal level of -30 dBc)
	(6) Transmission rate Accuracy Measuring range	\pm 1 ppm 42 kbps \pm 100 ppm
	(7) Waveform display	Constellation display
	(8) Measurement time	\leq 1 s (except for transmission rate measurement) \leq 3 s (Transmission rate measurement)

Table 1-5 MS8604A Specifications (8/18)

4.1.2	Amplitude measurement	<p>(1) Frequency range 10 MHz to 2.1 GHz</p> <p>(2) Input level range +10 to +40 dBm (Average power of a burst signal)</p> <p>(3) Transmission power Accuracy: $\pm 10\%$ (when using a high-power input and after calibration with MA4601A power sensor)</p> <p>(4) Carrier-off power Normal mode Measurement range : ≥ 65 dB Wide dynamic range mode Average noise level : ≤ -60 dBm (100 MHz \leq Freq. \leq 2.1 GHz) (Measurement range is ≥ 95 dB for 3 W input at average power within burst signal.)</p> <p>(5) Rise/fall characteristic Displays Rising/falling edges while synchronizing modulation data of characteristic a signal measured.</p> <p>(6) Measurement time ≤ 1 s</p> <p>(7) Impedance 50 Ω VSWR : ≤ 1.2</p>
4.1.3	Occupied bandwidth measurement	<p>(1) Frequency range 10 MHz to 2.1 GHz</p> <p>(2) Input level range +10 to +40 dBm (Average power of a burst signal)</p> <p>(3) Measurement Standard mode Measurement : Displays results of occupied bandwidth calculation after measuring a signal with Spectrum analyzer Measurement time : Approx. 12 s in full rate and when the number of data point is set to Normal</p> <p>High-speed mode Measurement : Displays results of occupied bandwidth calculation after Fourier transform of a signal under measurement Measurement time : ≤ 1 s</p>

Table 1-5 MS8604A Specifications (9/18)

4.1.4	<p>Adjacent Channel Leakage Power Measurement</p> <p>(1) Frequency range</p> <p>(2) Input level range</p> <p>(3) Measurement</p> <p style="padding-left: 40px;">Standard mode</p> <p style="padding-left: 40px;">High speed mode</p> <p>(4) Measurement range</p> <p style="padding-left: 40px;">Standard mode</p> <p style="padding-left: 40px;">High speed mode</p>	<p>100 MHz to 2.1 GHz</p> <p>+ 10 to + 40 dBm (Average power of a burst signal)</p> <p>Measurement : Displays results of adjacent channel leakage power calculation after measuring a signal with Spectrum analyzer.</p> <p>Measurement time : Approx. 13 s in full rate and when the number of data points is set to Normal in All mode</p> <p>Measurement : Displays results of adjacent channel leakage power measured through a built-in filter (Nyquist filter).</p> <p>Measurement time : ≤ 1.5 s</p> <p>≥ 60 dB (50 kHz offset)</p> <p>≥ 65 dB (100 kHz offset)</p> <p>≥ 60 dB (50 kHz offset)*2</p> <p>≥ 65 dB (100 kHz offset)*2</p> <p>*2 In High speed mode, ratio of Average power of a burst signal to Average value of adjacent channel leakage power at burst-on time</p>
4.1.5	<p>Spurious Measurement</p> <p>(1) Frequency range</p> <p>(2) Input level range (Transmission power)</p> <p>(3) Measurement range</p>	<p>10 MHz to 8.5 GHz</p> <p>except frequency range of ± 1 MHz of a carrier freq.</p> <p>+ 10 to + 40 dBm (Average power of a burst signal)</p> <p>≥ 65 dB (10 MHz to 1.7 GHz)</p> <p>≥ 75 dB (1.7 to 8.5 GHz)</p> <p>At carrier frequency range 800 MHz to 1.7 GHz</p>

Table 1-5 MS8604A Specifications (10/18)

4.2	Personal Handy Phone (PHS)	Option 12 Specifications below are guaranteed after pressing a key for optimizing an internal level.
4.2.1	Modulation/freq. measurement (1) Frequency range (2) Input level range (3) Carrier freq. Accuracy (4) Modulation precision Accuracy (5) Origin offset Accuracy (6) Transmission rate Accuracy Measuring range (7) Waveform display (8) Measurement time	10 MHz to 2.1 GHz - 10 to + 40 dBm (Average power of a burst signal)*3 *3 Down to a level by 20 dB lower than above level can be measured when using a low-power input terminal. ± (Accuracy of the reference oscillator + 10 Hz) ± (2% of an indicated value + 0.7%) ± 0.5 dB (to a signal level of - 30 dBc) ± 1 ppm 384 kbps ± 100 ppm Constellation display ≤ 1 s (except for transmission rate measurement) ≤ 2 s (Transmission rate measurement)

Table 1-5 MS8604A Specifications (11/18)

4.2.2	<p>Amplitude measurement</p> <p>(1) Frequency range</p> <p>(2) Input level range</p> <p>(3) Transmission power</p> <p>(4) Carrier-off power Normal mode Wide dynamic range mode</p> <p>(5) Rise/fall characteristic</p> <p>(6) Measurement time</p> <p>(7) Impedance</p>	<p>10 MHz to 2.1 GHz</p> <p>+ 10 to + 40 dBm (Average power of a burst signal)</p> <p>Accuracy : $\pm 10 \%$ (when using a high-power input and after calibration with MA4601A power sensor)</p> <p>Measurement range : ≥ 55 dB Average noise level : ≤ -50 dBm (100 MHz \leq Freq. \leq 2.1 GHz) (Measurement range is ≥ 69 dB at 10 mW input of average power), (Burst average power: 80 mW)</p> <p>Displays Rising/falling edges while synchronizing modulation data of characteristic a signal measured.</p> <p>≤ 1 s</p> <p>50 Ω VSWR : ≤ 1.2</p>
4.2.3	<p>Occupied bandwidth measurement</p> <p>(1) Frequency range</p> <p>(2) Input level range</p> <p>(3) Measurement Standard mode High-speed mode</p>	<p>10 MHz to 2.1 GHz</p> <p>+ 10 to + 40 dBm (Average power of a burst signal)</p> <p>Measurement : Displays results of occupied bandwidth calculation after measuring a signal with Spectrum analyzer Measurement time : Approx. 4 s in full rate and when the number of data point is set to Normal</p> <p>Measurement : Displays results of occupied bandwidth calculation after Fourier transform of a signal under measurement Measurement time : ≤ 1 s</p>

Table 1-5 MS8604A Specifications (12/18)

4.2.4	Adjacent Channel Leakage Power Measurement	<p>(1) Frequency range 100 MHz to 2.1 GHz</p> <p>(2) Input level range +10 to +40 dBm (Average power of a burst signal)</p> <p>(3) Measurement</p> <p style="padding-left: 20px;">Standard mode</p> <p>Measurement : Displays results of adjacent channel leakage power calculation after measuring a signal with Spectrum analyzer.</p> <p>Measurement time : Approx. 5 s in full rate and when the number of data points is set to Normal in All mode</p> <p style="padding-left: 20px;">High-speed mode</p> <p>Measurement : Displays results of adjacent channel leakage power measured through a built-in filter (Nyquist filter).</p> <p>Measurement time : ≤ 1.5 s</p> <p>(4) Measurement range</p> <p style="padding-left: 20px;">Standard mode</p> <p>≥ 60 dB (600 kHz offset)</p> <p>≥ 60 dB (900 kHz offset)</p> <p style="padding-left: 20px;">High-speed mode</p> <p>≥ 60 dB (600 kHz offset)*4</p> <p>≥ 60 dB (900 kHz offset)*4</p> <p>*4 In High-speed mode, ratio of Average power of a burst signal to Average value of adjacent channel leakage power at burst-on time</p>
4.2.5	Spurious Measurement	<p>(1) Frequency range 10 MHz to 8.5 GHz except frequency range of ± 50 MHz of a carrier freq.</p> <p>(2) Input level range (Transmission power) +10 to +40 dBm (Average power of a burst signal)</p> <p>(3) Measurement range</p> <p style="padding-left: 20px;">≥ 60 dB (10 MHz to 1.7 GHz)</p> <p style="padding-left: 20px;">≥ 70 dB (1.7 to 8.5 GHz)</p> <p>At carrier frequency range 800 MHz to 2.1 GHz</p>

Table 1-5 MS8604A Specifications (13/18)

4.3	North American Digital Cellular (NADC)	Option 13 Specifications below are guaranteed after pressing a key for optimizing an internal level.
4.3.1	Modulation/freq. measurement	
	(1) Frequency range	400 kHz to 2.1 GHz
	(2) Input level range	- 10 to + 40 dBm (Average power of a burst signal)*1 *1 Down to a level by 20 dB lower than above level can be measured when using a low-power input terminal.
	(3) Carrier freq. Accuracy	\pm (Accuracy of the reference oscillator + 1 Hz)
	(4) Modulation precision Accuracy Range	\pm (2 % of an indicated value + 0.5 %) 0 to 12.5 %
	(5) Origin offset Accuracy	\pm 0.5 dB (to a signal level of - 30 dBc)
	(6) Transmission rate Accuracy Measuring range	\pm 1 ppm 48.6 kbps \pm 100 ppm
	(7) Waveform display	Constellation display
	(8) Measurement time	\leq 1 s (except for transmission rate measurement) \leq 3 s (Transmission rate measurement)

Table 1-5 MS8604A Specifications (14/18)

4.3.2	Amplitude measurement	
(1)	Frequency range	10 MHz to 2.1 GHz
(2)	Input level range	+ 10 to + 40 dBm (Average power of a burst signal)
(3)	Transmission power	Accuracy : $\pm 10\%$ (when using a high-power input and after calibration with MA4601A power sensor)
(4)	Carrier-off power	Measurement range : ≥ 65 dB
	Normal mode	Average noise level : ≤ -60 dBm
	Wide dynamic range mode	(100 MHz \leq Freq. \leq 2.1 GHz)
		(Measurement range is ≥ 95 dB at + 36 dBm input of average power of a burst signal.)
(5)	Rise/fall characteristic	Displays Rising/falling edges while synchronizing modulation data of characteristic a signal measured.
(6)	Measurement time	≤ 1 s
(7)	Impedance	50 Ω VSWR : ≤ 1.2
4.3.3	Occupied bandwidth measurement	
(1)	Frequency range	10 MHz to 2.1 GHz
(2)	Input level range	+ 10 to + 40 dBm (Average power of a burst signal)
(3)	Measurement	
	Spectrum analyzer mode	Measurement : Displays results of occupied bandwidth calculation after measuring a signal with Spectrum analyzer
		Measurement time : Approx. 12 s in full rate and when the number of data point is set to Normal
	High-speed mode	Measurement : Displays results of occupied bandwidth calculation after Fourier transform of a signal under measurement
		Measurement time : ≤ 1 s

Table 1-5 MS8604A Specifications (15/18)

4.3.4	<p>Adjacent Channel Leakage Power Measurement</p> <p>(1) Frequency range</p> <p>(2) Input level range</p> <p>(3) Measurement</p> <p style="padding-left: 40px;">Spectrum analyzer mode</p> <p style="padding-left: 40px;">High speed mode</p> <p>(4) Measurement range</p> <p style="padding-left: 40px;">High speed mode</p>	<p>100 MHz to 2.1 GHz</p> <p>+ 10 to + 40 dBm (Average power of a burst signal)</p> <p>Measurement : Displays results of adjacent channel leakage power calculation after measuring a signal with Spectrum analyzer.</p> <p>Measurement time : Approx. 13 s in full rate and when the number of data points is set to Normal</p> <p>Measurement : Displays results of adjacent channel leakage power measured through a built-in filter (Nyquist filter).</p> <p>Measurement time : ≤ 2 s</p> <p>≥ 30 dB (30 kHz offset)*2 ≥ 60 dB (60 kHz offset)*2 ≥ 65 dB (90 kHz offset)*2</p> <p>*2 In High speed mode, ratio of Average power of a burst signal to Average value of adjacent channel leakage power at burst-on time</p>
4.3.5	<p>Spurious Measurement</p> <p>(1) Frequency range</p> <p>(2) Input level range (Transmission power)</p> <p>(3) Measurement range</p>	<p>10 MHz to 8.5 GHz except frequency range of ± 1 MHz of a carrier freq.</p> <p>+ 10 to + 40 dBm (Average power of a burst signal)</p> <p>≥ 65 dB (10 MHz to 1.7 GHz) ≥ 75 dB (1.7 to 8.5 GHz)</p> <p>At carrier frequency range 800 MHz to 1.7 GHz</p>
4.4	<p>I/Q input</p> <p>(1) Input level range</p> <p>(2) Input impedance</p> <p>(3) Measurement items</p>	<p>Option 3</p> <p>0.3 to 1.5 V peak</p> <p>5 kΩ, AC/DC coupling (switchable)</p> <p>Modulation, Amplitude, Occupied frequency bandwidth</p>

Table 1-5 MS8604A Specifications (16/18)

5	OTHERS	
5.1	Display	640×400 dots, 9-inch EL
5.2	Inputs/outputs on the rear panel	Reference oscillator input : 10 MHz ± 10 Hz, 2 to 5 V _{p-p} , ≥ 50 Ω, BNC connector Reference oscillator buffer output : 10 MHz, 2 to 3 V _{p-p} (200 Ω terminator), BNC connector Separate video output : Compatible to UA455A, 8-pin connector
5.3	External memory	One slot for a memory card, Data Storage unit MC8104A can be used.
5.4	Save/recall	Built-in memory (4 sets of spectrum and TX test conditions), Can save/recall setting conditions on a external memory (PMC card)
5.5	Direct plotting	Can hard-copy data on the CRT through GPIB.
5.6	External control	
	(1) GPIB 1 (IEEE 488.2)	The device is specified as a device, can be controlled by an external controller, and all functions except a power switch can be controlled. Can control other instruments as a controller when using PTA. SH1, AH1, T6, L4, SR1, RL1, PP0 DC1, DT1, C0 (C1, C2, C3 and C24 when using PTA)
	(2) GPIB 2 (IEEE 488.1)	The mainframe is specified as a controller, which controls external instruments as a controller. SH1, AH1, T6, L4, SR0, RL0, PP0 DC0, DT0, C1, C2, C3, C4, C28
	(3) I/O port	Output port A/B : 8-bit (TTL level) Input/Output port C/D : 4-bit (TTL level) Exclusive port : 3-bit (TTL level) Control signal : 4 (TTL level) +5 V output : max. 50 mA
	(4) RS-232C (Option 02)	The mainframe is specified as a controller, which controls external instruments.

Table 1-5 MS8604A Specifications (17/18)

5.7	PTA (1) Language (2) Programming (3) Program memory (4) Programming capacity	PTL : High level language similar to BASIC (interpeter) Can be edited using an external keyboard on the main frame EL. Memorable on a memory card or on the MC8104A and Up-load/Down-load is possible from a PC. 900 k bytes (including variable area)
-----	--	---

Table 1-5 MS8604A Specifications (18/18)

6	Dimensions, mass, power	
6.1	Dimensions	221.5 H × 426 W × 451 D mm
6.2	Mass	≤ 27 kg
6.3	Power	47.5 to 63 Hz, ≤ 500 VA 85 to 132 Vac (100 Vac system) 170 to 250 Vac (200 Vac system)
7	Temperature range	0° to 50 °C

SECTION 2 PREPARATIONS BEFORE USE

This section explains the preparations and safety procedures that should be performed before using the MS8604A. The safety procedures are to prevent the risk of injury to the operator and damage to the equipment. Insure that you understand the contents of the pre-operation preparations before using the MS8604A. For the GPIB cable connection and the GPIB address setting, refer to the separate GPIB operation manual.

TABLE OF CONTENTS

2.1	Installation Site and Environment Conditions	2-3
2.2	Safety Measures	2-4
2.2.1	Power-on	2-4
2.2.2	Maximum reverse power to RF Output connector	2-5
2.3	Preparations before Power-on	2-6
2.3.1	Protective grounding	2-7
2.3.2	Replacing fuse	2-8
2.4	Precautions for Handling Storage Media	2-10
2.4.1	Floppy disks	2-10
2.4.2	Plug-in memory cards (PMC)	2-11

(Blank)

2.1 Installation Site and Environmental Conditions

The MS8604A operates normally at temperatures from 0 to 50 °C. However, for the best performance, the following locations should be avoided.

- Where there is severe vibration
- Where the humidity is high
- Where the equipment will be exposed to direct sunlight
- Where the equipment will be exposed to active gases

In addition to meeting the above conditions, to insure long-term trouble-free operation, the equipment should be used at room temperature and in a location where the power supply voltage does not fluctuate greatly.

CAUTION

If the MS8604A is used at normal temperatures after it has been used or stored for a long time at low temperatures, there is a risk of short-circuiting caused by condensation. To prevent this risk, do not turn the power on until it has been allowed to dry out sufficiently.

Fan clearance

To suppress any internal temperature increase, the MS8604A has a fan on the rear panel as shown in the diagram below. Leave a gap of at least 10 cm between the rear panel and the wall, nearby equipment or obstructions so that fan ventilation is not blocked.

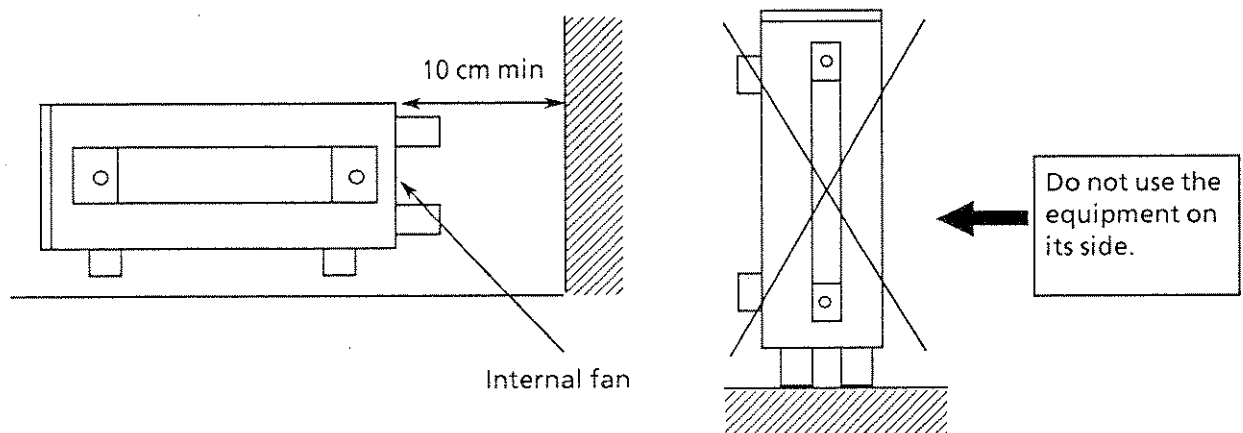

2.2 Safety Measures

This paragraph explains the safety procedures which should be followed under all circumstances not to counter the risk of an accidental electric shock, damage to the equipment or a major operation interruption.

2.2.1 Power-on

WARNING

- *Before power-on:* *The MS8604A must be connected to protective ground. If the power is turned on without taking this countermeasure, there is a risk of receiving an accidental electric shock. In addition, it is essential to check the power supply voltage. If an abnormal voltage that exceeds the specified value is input, there is an accidental risk of damage to the MS8604A and fire.*
 - *During power-on:* *To maintain the MS8604A, sometimes it is necessary to make internal checks and adjustments with the top, bottom or side covers removed while power is supplied. Very-high, dangerous voltages are used in the MS8604A; if insufficient care is taken, there is a risk of an accidental electric shock being received or of damage to the equipment. To maintain the MS8604A, request service by a service personnel who has received the required training.*
-

In the following, special notes on safety procedures are explained for sections other than Section 2. To prevent accidents, read this section together with the related sections before beginning operation.

2.2.2 Maximum reverse power to RF Output connector

CAUTION

The MS8604A has not a power protective circuit from excessive power. The upper limit values are 10 W (High Power Input) and 100 mW (Low Power Input). Never apply power more than these value.

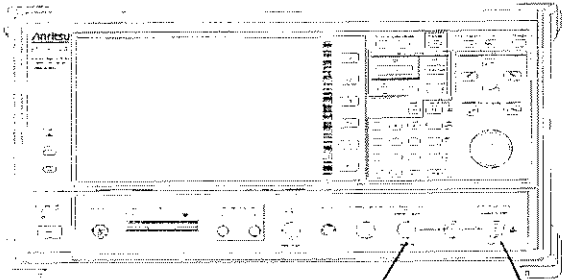

Low Power Input
50 Ω
100 Hz-8.5 GHz

High Power Input
50 Ω
100 Hz-8.5 GHz



2.3 Preparations before Power-on

The MS8604A operates normally when it is connected to an **Vac +10 % or -15 % AC power supply. To prevent the following problems, take the necessary procedures described on the following pages before power is supplied.

- Accidental electric shock
- Damage caused by abnormal voltage
- Ground current problems

Note: • The voltage and current ratings are indicated on the rear panel when the instrument is shipped from the factory.

- In this manual, the power supply voltage and current ratings are represented by **Vac and ***A, respectively.

To protect the operator, the following WARNING and CAUTION notices are attached to the rear panel of the MS8604A.

WARNING 
NO OPERATOR SERVICE-
ABLE PARTS INSIDE.
REFER SERVICING TO
QUALIFIED PERSONNEL.

CAUTION 
FOR CONTINUED FIRE
PROTECTION REPLACE
ONLY WITH SPECIFIED
TYPE AND RATED FUSE.

WARNING

Disassembly, adjustment, maintenance, or other access inside this instrument by unqualified personnel should be avoided. Maintenance of this instrument should be performed only by Anritsu trained service personnel who are familiar with the risks involved of fire and electric shock. Potentially lethal voltages existing inside this instrument, if contacted accidentally, may result in personal injury or death, or in the possibly of damage to precision components.

Always follow the instructions on the following pages.

2.3.1 Protective grounding

(1) Grounding with 3-pole power outlet

When connecting to a 3-pole (grounded, 2-pole type) ac power-supply outlet, the frame of the MS8604A is connected to ground potential. As a result, it is not necessary to connect the FG terminal to ground.

(2) Grounding with frame ground (FG) terminal

WARNING

If power is supplied without protective grounding, there is a risk of accidental electric shock. When a 3-pole power-supply outlet is not available, the protective frame-ground (FG) terminal on the rear panel must be connected to ground potential before power is supplied to the MS8604A.

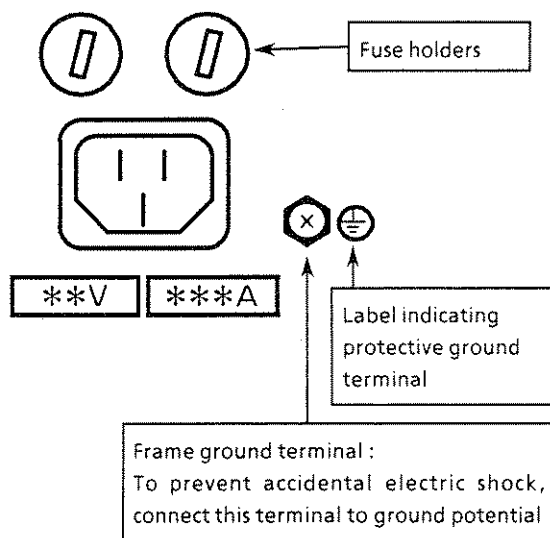

When there is no 3-pole ac power-supply outlet, the protective frame-ground (FG) terminal on the rear panel must be connected directly to ground potential.

2.3.2 Replacing fuse

WARNING

- *If the fuses are replaced while power is being supplied, there is a serious risk of electric shock. Before replacing the fuses, set the power switch to OFF and remove the power cord from the power outlet.*
 - *If power is supplied without protective grounding, there is a risk of accidental electric shock. In addition, if the AC power supply voltage is unsuitable, there is a risk of the internal circuits of the MS8604A being damaged by the abnormal voltage. Before supplying power again after changing the fuses, check that the protective grounding described previously is still connected, and check that the AC power supply voltage is suitable. Then, set the power switch to ON.*
-

CAUTION

When there are no supplied spare fuses, the replacement fuses must have the same rated voltage and current as the fuses in the fuse holders.

- *If the replacement fuses are not of the same type, they may not fit correctly, there may be a faulty connection, or the time taken to for the fuses to blow may be too long.*
 - *If the voltage and current rating of the fuses is incorrect, when an abnormality occurs again, the fuses may not blow with a consequent risk of damage to the equipment by fire.*
-

The MS8604A with standard accessories has two spare *** A fuses. The fuses are mounted in the fuse holder as shown in the figure below and must be replaced if they blow. If the fuses must be replaced, locate and remedy the cause before replacing the blown fuses. In addition to this fuse replacement, make sure that each item shown in the table below is properly selected for the power supply system.

Power supply system	VOLTAGE SELECT	Line-voltage rating plate	Fuse rating plate	Fuse rating	Fuse name	Model/ Order No.
100 Vac	AC 100 V	85 – 132 V	T 6.3 A	6.3 A, 250 V	T6.3 A 250 V	F0014
200 Vac	AC 200 V	170 – 250 V	T 6.3 A	6.3 A, 250 V	T6.3 A 250 V	F0014

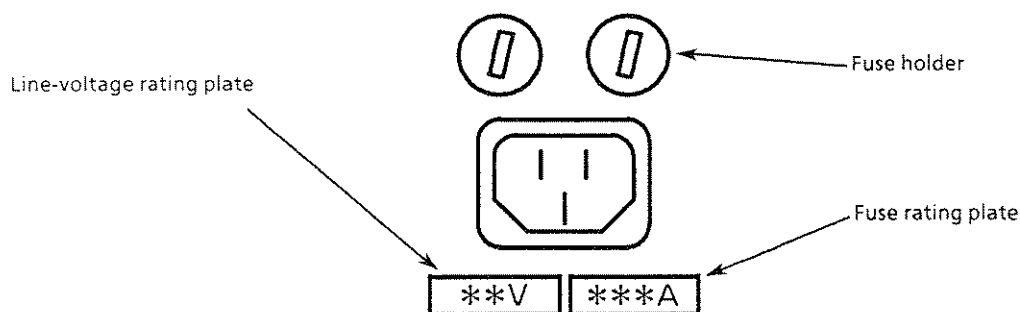

After performing the safety procedures described on the preceding page, replace the fuses according to the following procedure.

Step	Procedure
1	Set the front-panel [Power] switch to standby and the rear-panel [Line] switch to OFF. Then, remove the power cord from the power-supply outlet.
2	Use a flat-bladed screwdriver to turn the fuse-holder cap counterclockwise. The cap and fuse are removed as a unit from the fuse holder.
3	Remove the fuse from the fuse cap and replace it with a spare fuse. (The direction does not matter.)
4	Return the fuse cap with fuse to the fuse holder and fasten it by turning it clockwise with the flat-bladed screwdriver.

2.4 Precautions for Handling Storage Media

CAUTION

Storage media such as the plug-in memory card or floppy disk should never be removed from the equipment (MS8604A/MC8104A) while it is being accessed (while the Busy lamp on the equipment is lit), since this may damage the media.

The MS8604A uses plug-in memory cards (PMC) as the storage media for data and programs. In addition, floppy disks (in the MC8104A Data Storage Unit as a peripheral device) can be used.

If an error is made in handling these storage media or an accident occurs, data may be lost. Anritsu recommends that you always back-up your data.

ANRITSU WILL NOT BE HELD RESPONSIBLE FOR LOST DATA.

Items that should be noted about handling floppy disks and PMCs are explained below.

2.4.1 Floppy disks

CAUTION

- *Store disks under the specified environmental conditions and do not use them in very dusty locations.*
 - *Do not expose disks to magnetic fields and do not bend them.*
-

If the contents of the above CAUTION are not observed, reading and writing of floppy disks may be impossible so please pay attention to them.

2.4.2 Plug-in memory cards (PMC)

The following items are explained for plug-in memory cards (PMCs).

- Inserting PMC into MS8604A slot
- Precautions for handling PMC
- Using the cap
- Battery Installation and Replacement Method
- Using the write-protection switch (only for SRAM PMCs)

(1) Inserting PMC into MS8604A slot

CAUTION

If the PMC is forcibly inserted, the PMC connector pins may be damaged. Insert the PMC as shown in the diagram below.

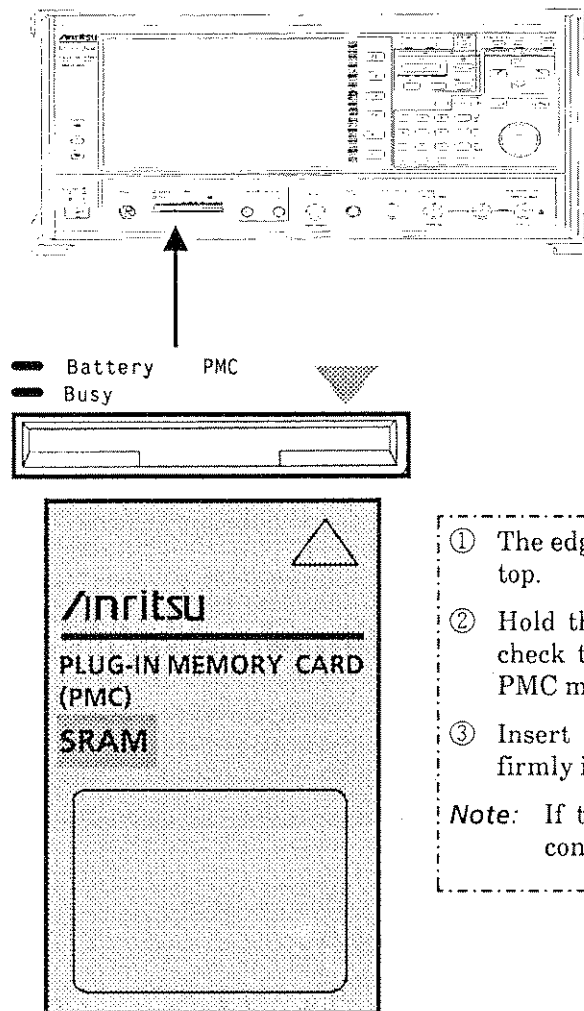

- ① The edge with green triangular mark must be at the top.
- ② Hold the PMC to the MS8604A insertion slot and check that the arrow mark on the top edge of the PMC matches the arrow mark on the MS8604A.
- ③ Insert the PMC straight into the slot until it is firmly in position.

Note: If the PMC is forced into the slot, the PMC connector may be damaged.

Insert the PMC into the MS8604A slot correctly according to the above procedure.

(2) Precautions for handling PMC

- 1) Do not drop or bend the PMC or subject it to strong mechanical shock.
- 2) Do not let the PMC get wet.
- 3) Do not expose the PMC to high temperatures or humidity, or to direct sunlight.
- 4) Do not insert anything into the PMC connector.
- 5) Do not let foreign material or dust enter the PMC connector.
- 6) Do not insert anything other than the specified PMC into the PMC slot.
- 7) The 128, 256 and 512 KB PMCs are shipped without the battery installed so use them after installing the supplied battery.
- 8) The life of the PMC battery at normal temperature is shown in the table below. If this battery life is exceeded, saved data and programs may be lost. We recommend that the battery be replaced before the listed battery life expires.

As the following diagram shows, a line is provided on the rear side of the PMC for entry of the scheduled battery replacement date. After battery has been installed, we recommend that you refer to this table and enter the scheduled battery replacement data on the PMC.

PMC type	Memory capacity	Battery life	Battery
BS32F1-C	32 KB	5 years approx.	BR2325
BS64F1-C	64 KB	5 years approx.	
BS128F1-C	128 KB	4.3 years approx.	
BS256F1-C	256 KB	2.2 years approx.	
BS512F1-C	512 KB	1.1 years approx.	

After installing the battery, insert the scheduled battery replacement date on this line

CAUTION

- 電池寿命(32Kバイト):約5年(常温)
Battery life: About 5 years
(at room temperature)
- 機器電源をONにして、プラグイン状態で電池を交換して下さい。
Battery replacement must be done by inserting the card into the instrument while the power is on.
- 電池はBR2325を使用して下さい。
Use only BR2325 battery.
- 強いショックを与えたり、折り曲げないこと。
Do not drop or bend.
- 高温高湿・直射日光にさらさないこと。
Do not expose to extreme temperature or wetness.

次回電池交換予定日
Battery replacement Schedule
Date : _____

ANRITSU CORP. MADE IN JAPAN

The MS8604A has a red 'Battery' lamp for monitoring the built-in battery voltage. When this lamp lights red, replace the discharged battery promptly.

(3) Using the cap

Since the cap prevents the PMC from being inserted upside-down, it should be mounted whenever the PMC is used. However, it should be removed in the following cases:

- When the following type of PMC insertion slot is used, the cap should be removed.

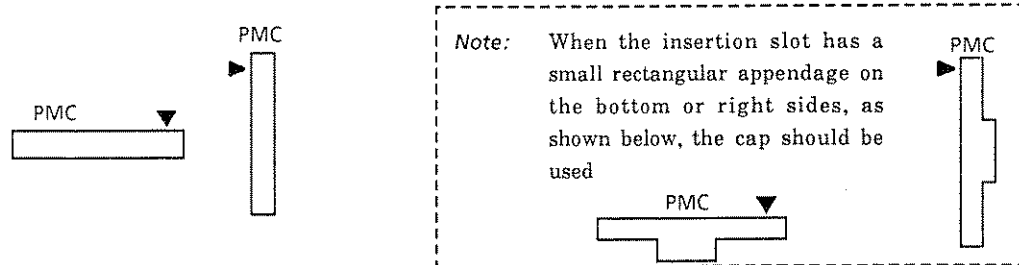

It is necessary to remove the cap when installing or replacing the battery.

[Removing the cap]

Position the PMC back-side up (such that the CAUTION faces upwards) so that the cap can be easily removed.

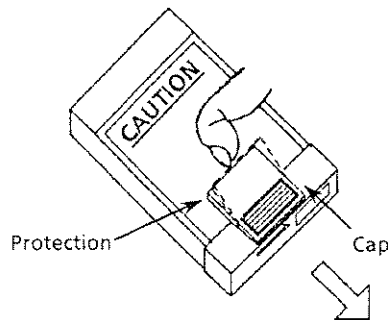

While slightly lifting the cap protection (as indicated by the dotted line), push the cap in the direction of the arrow

(4) Battery Installation and Replacement Method

■ Installing the battery (only for SRAM PMCs)

When using the PMC, be certain to install the lithium battery that has been included. When installing the battery, turn the PMC back-side up (so that CAUTION faces upwards), and follow this procedure:

- ① Take the cap off the PMC.
- ② Release the battery holder lock, and remove the battery holder.
- ③ Turn the lithium-battery so that the + side faces up, and install the battery in the battery holder.
- ④ Insert the battery holder into the PMC, and engage the battery holder lock. Then remount the cap.

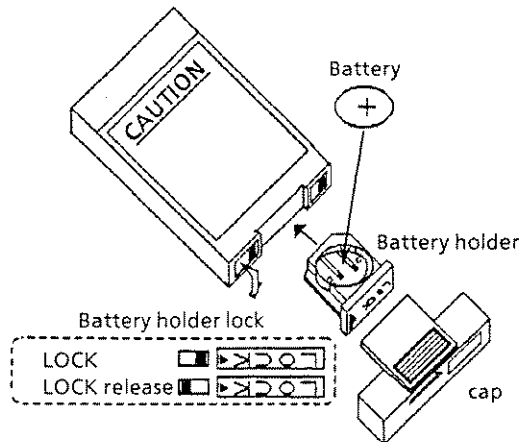

■ Replacing the battery (only for SRAM PMCs)

When replacing the battery, first turn the instrument power ON, then mount the PMC in the instrument, before performing the following procedure:

(Attention: PMC data will be lost, if this procedure is not followed.)

Step	Procedure
1	Prepare the lithium battery.
2	Turn the instrument power ON.
3	Take the cap off the PMC, and mount the PMC in the instrument. (When mounting, align the ▼ marks.)
4	Release the battery holder lock.
5	Remove the battery holder, and replace the old battery with new one.
6	Reinsert the battery holder into the PMC, and engage the battery holder lock.
7	Take the PMC out of the instrument, and mount the cap.

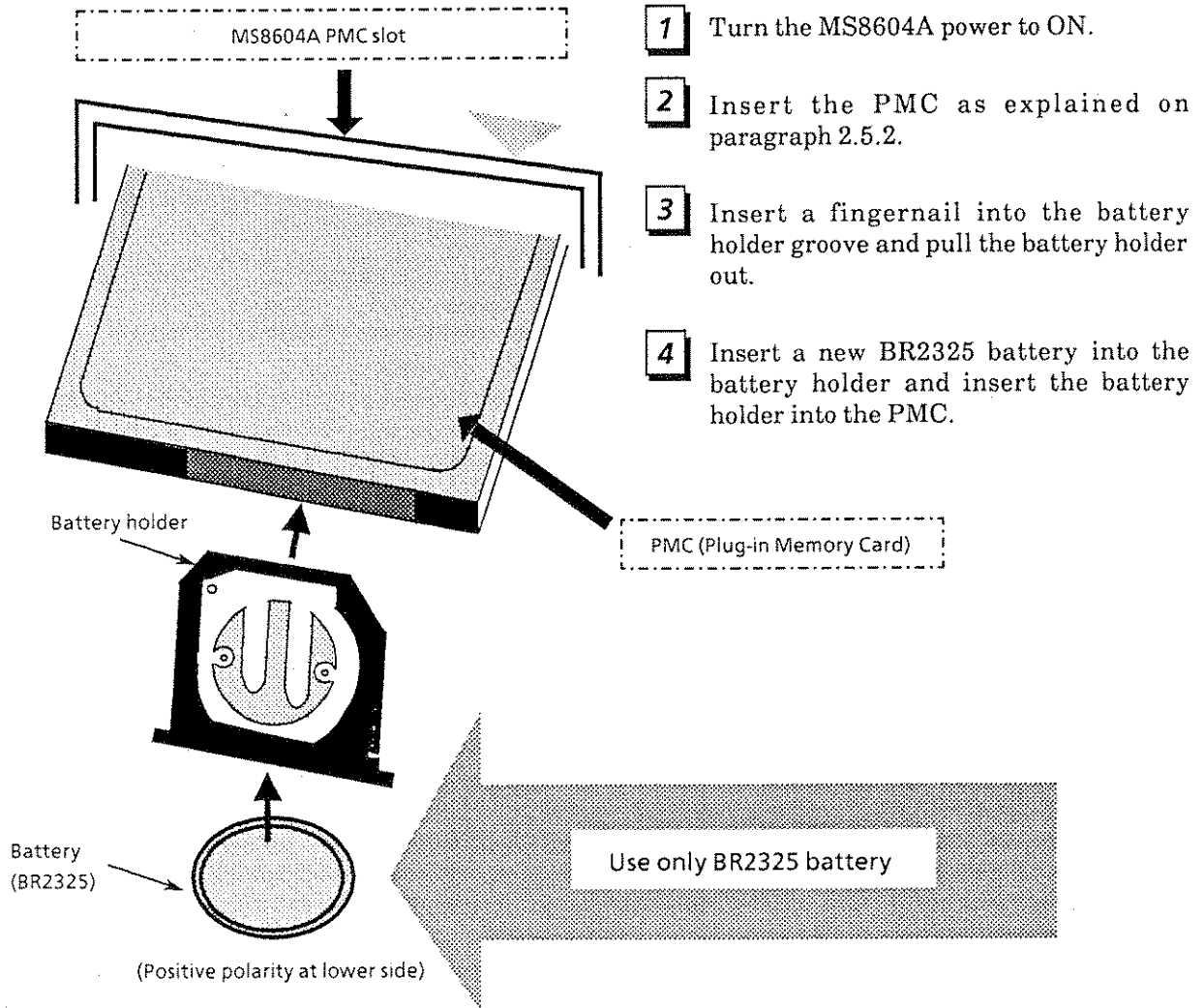

■ Locking Battery Holder

The PMC battery holder has a slide switch to lock it to PMC. To lock it, slide the switch to the left with the tip of a pencil etc.

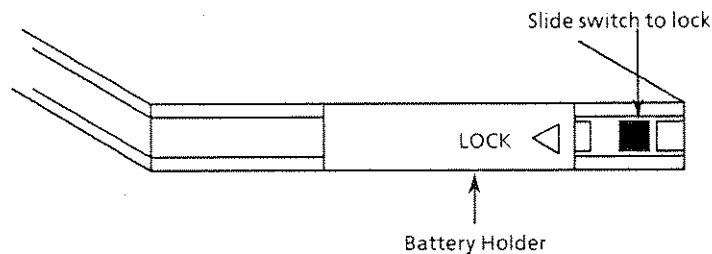

(5) Using the write-protection switch (only for SRAM PMCs)

The write-protection switch has been preset at the factory to the "OFF" position. To enable write protection, move the switch to the ON position with a ball point pen.

If the software for the instrument performs write protection, set the write-protection switch to the "OFF" position.

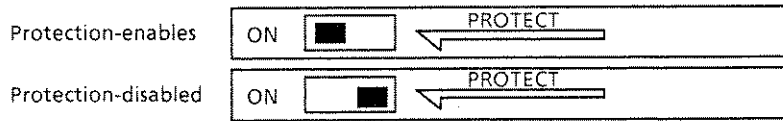

SECTION 3

PANEL LAYOUT AND OVERVIEW OF OPERATION

This section describes the layout, functions, and operation of the keys, connectors, indicators, and other parts on the MS8604A front and rear panels. For the detailed operating instructions, see Section 4.

TABLE OF CONTENTS

3.1	Panel Layout	3-3
3.1.1	Front panel keys and rotary knob	3-3
3.1.2	Front panel connectors	3-6
3.1.3	Rear panel layout	3-7
3.1.4	Panel layout	3-8
3.2	Overview of Operation	3-11
3.2.1	Overview of functions	3-11
3.2.2	Overview of operation	3-12

(Blank)

3.1 Panel Layout

This paragraph describes the MS8604A keys, switches, LEDs, connectors, and other parts on the MS8604A front and rear panels. (See Fig. 3-1 and Fig. 3-2.)

3.1.1 Front panel keys and rotary knob

This paragraph describes the type, attributes and functions of the front panel keys and the rotary knob.

No.	Type (marking) of key	Key attribute	Function
1	Shift	Momentary	Switches the function of keys with a Shift function. The Shift function is toggled ON/OFF each time this key is pressed.
2	F1, F2, F3, F4, F5, F6	Momentary	Function keys Group of keys that select and execute the corresponding menu displayed on the EL screen.
3	Single	Momentary	Performs one measurement.
4	Continuous	Momentary	Performs continuously measurement.
5	Main Function key group	————	Key group that selects and switches the measurement mode.
	System	Momentary	Selects system mode.
	TX Test	Momentary	Selects transmitter tester mode.
	Spectrum	Momentary	Selects spectrum mode.
	Frequency	Momentary	Selects the frequency data setting function when spectrum mode has been selected. Input from this key is effective only when spectrum mode has been selected.
	Span	Momentary	Selects the span data setting function when spectrum mode has been selected. Input from this key is effective only when spectrum mode has been selected.
6	Amplitude	Momentary	Selects the level data setting function when the spectrum mode has been selected. Input from this key is effective only when spectrum mode has been selected.
	Copy Control C o p y	Momentary	Selects and executes the copy function. The following functions are switched by pressing the [Shift] key on and off: [Shift] OFF : If copying is stopped, it is started. [Shift] ON : Expands and displays the copy control menu.

Front panel keys and the rotary knob

No.	Type (marking) of key	Key attribute	Function
7	S a v e R e c a l l	Momentary	Selects and executes the internal memory/external memory parameters and measurement data Recall/Save function. The following functions are switched by pressing the [Shift] key on and off: [Shift] OFF : Selects the Recall function. [Shift] ON : Selects the Save function.
8	ENTRY	————	Data input keys.
	^, v, >, <	Momentary	Moves the cursor on the EL screen.
	0, 1, 2, 3, 4, 5, 6, 7, 8, 9, ., +/–	Momentary	Numeric keys (ten-key pad) used in data input.
	H o l d B S	Momentary	BS is the back space key used in data correction during data input from the numeric keys. Hold holds the key input. The following functions are switched by pressing the [Shift] key on and off: [Shift] OFF : Selects the BS function. [Shift] ON : Selects the Hold function.
	Valid key group	————	Keys that enter data during data input from the ten-key pad.
	[GHz/dBm/dB]	Momentary	Validates data when GHz/dBm/dB units system data is input.
	[MHz/V/s]	Momentary	Validates data when MHz/V/sec units system data is input.
	[kHz/mV/ms]	Momentary	Validates data when kHz/mV/ms units system data is input.
	[Hz/ μ V/ μ s/Enter]	Momentary	Validates data when Hz/ μ V/ μ s units system data is input.
	Step/Select (^, v)	Momentary	Numeric data increment/decrement keys. [^] is the numeric data increment key and [v] is the numeric data decrement key. For input by these keys, data is validated each time it is incremented/decremented. These keys are also used in item selection.
	Rotary knob	————	Data input knob. When this knob is turned clockwise, the value increases and when it is turned counterclockwise, the value decreases. For input by rotary knob, data is validated each time it is incremented/decremented. This knob is also used in item selection.

Front panel keys and the rotary knob

No.	Type (marking) of key	Key attribute	Function
9	Preset	Momentary	Initializes the setup parameters.
10	Local	Momentary	Resets GPIB remote mode and returns to local mode. In GPIB remote mode, the LED (Remote) lights.
11	PTA	Momentary	Turns on the PTA function. When the PTA function is ON, the LED lights. When the PTA function is ON, only input from the 0 to 9, . , +/-, BS, Enter, and Local keys is effective.
12	Power switch		Switches power Standby/ON when the rear panel Line Input ON/OFF switch is ON. In Standby mode, power is supplied to the reference crystal oscillator only.

3.1.2 Front panel connectors

No.	Connector marking	Function
13	Keyboard	Connector that connects the keyboard for program editing by PTA.
14	PMC	Slot for installing a PMC (Plug-in Memory Card) to save data. In TX Test mode, only the setup conditions can be saved. In spectrum mode, the setup conditions and waveform data can be saved. When PTA is used, PTA programs and data can be saved. When the PMC battery capacity becomes low, the Battery lamp (red) lights. While the PMC is being accessed, the Busy lamp (green) lights.
15	I/Q INPUT I Q	Modulation analysis can be performed by applying an IQ baseband signal to this connector. This connector is optional.
16	Cal Output 0 dBm 50 MHz	Signal output for power measurement calibration.
17	Sensor Input	Connects the power measurement sensor.
18	To Power Sensor	In TX Test mode, the level of the measured signal can be measured with a power meter by connecting a power sensor to this connector.
19	Low Power Input 50 Ω 100 Hz-8.5 GHz 100 mW Max	When the measurement signal is very low level, it is input via this connector. However, for Low Power Input, the level is not guaranteed.
20	— 20 dB —	Attenuates the signal input at connector No. 21 by 20 dB and outputs it.
21	High Power Input 50 Ω 100 Hz-8.5 GHz 10 W Max	Measurement signals of 10 W (+40 dBm) or less are input via this connector.

3.1.3 Rear panel layout

No.	Marking	Function
22	(Fan)	Instrument internal air cooling fan.
23	10 MHz Reference	Reference signal (10 MHz) internal signal output connector and external signal input connector. Usually, Output and Input are connected by a U-link.
	Output	Internal reference signal (10 MHz) output connector.
	Input	External reference signal (10 MHz) input connector.
	Buffered Out	Reference signal (10 MHz) buffer output connector.
24	Video Output Separate	Video separate signal for screen monitoring.
25	P-I/O	Parallel I/O interface connector.
26	GPIB 2	GPIB2 interface connector.
27	GPIB 1	GPIB1 interface connector.
28	RS232C	RS-232C interface connector.
29	IF Output 21.4 MHz	Spectrum analyzer IF signal output connector.
30	Trigger Input1 Input2 ± 10 V TTL	Input connector for external trigger signal used in spectrum mode.
31	Y Output	Spectrum mode vertical axis display signal output connector.
32	~Line Input	Power AC input switch. When this switch is turned off, the power is not turned on even if the front panel power switch is turned on.
33	(Fuse)	Power supply fuse. For safety, always use a fuse of the specified rating.
34	(Frame ground terminal)	When the power cord is two-core, for safety, always ground this terminal.
35	(Power inlet)	For safety, always use a power source of the rated voltage.

3.1.4 Panel layout

The front panel and rear panel layout is shown in Fig. 3-1 and Fig. 3-2.

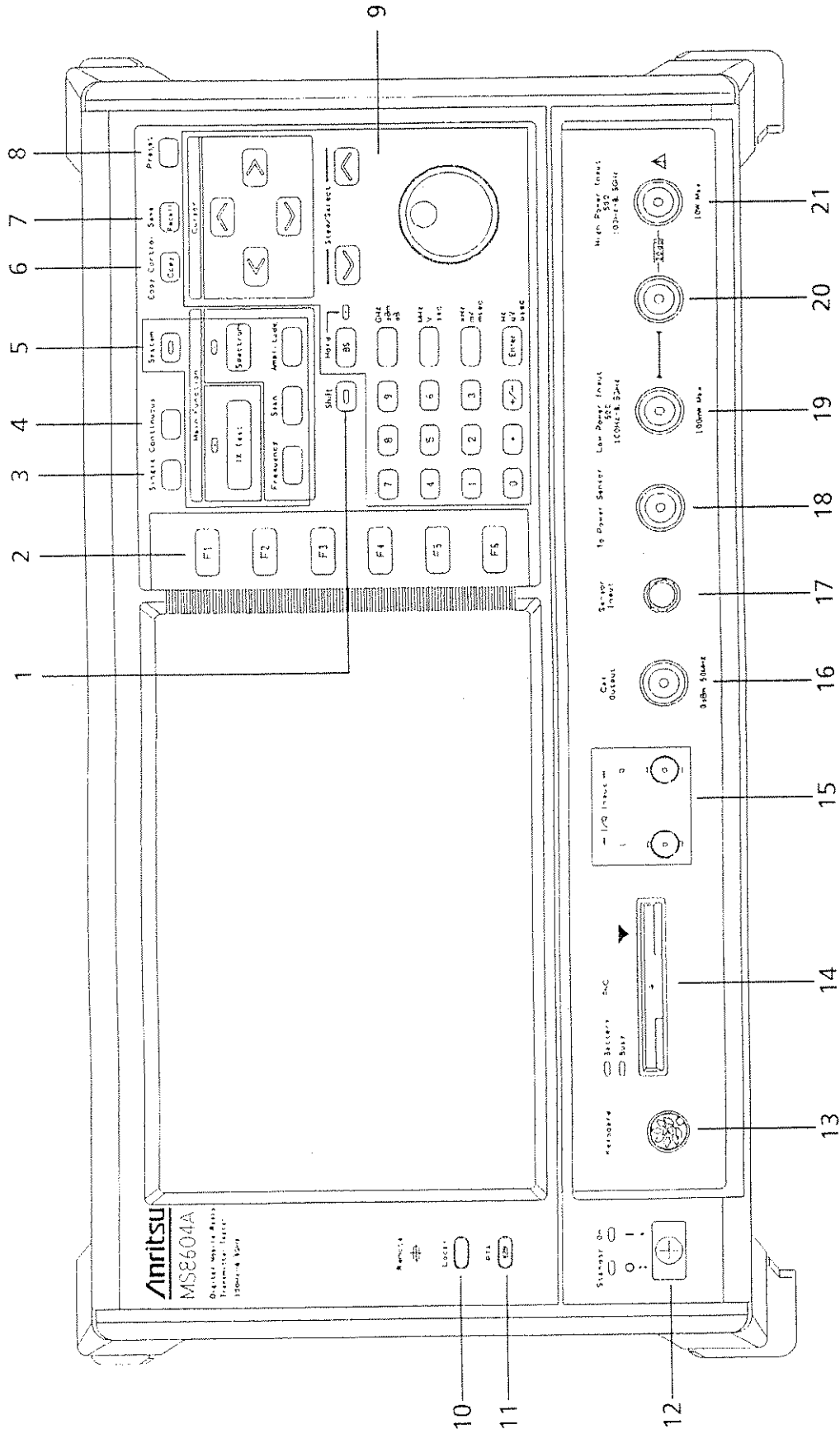

Fig. 3-1 Front Panel

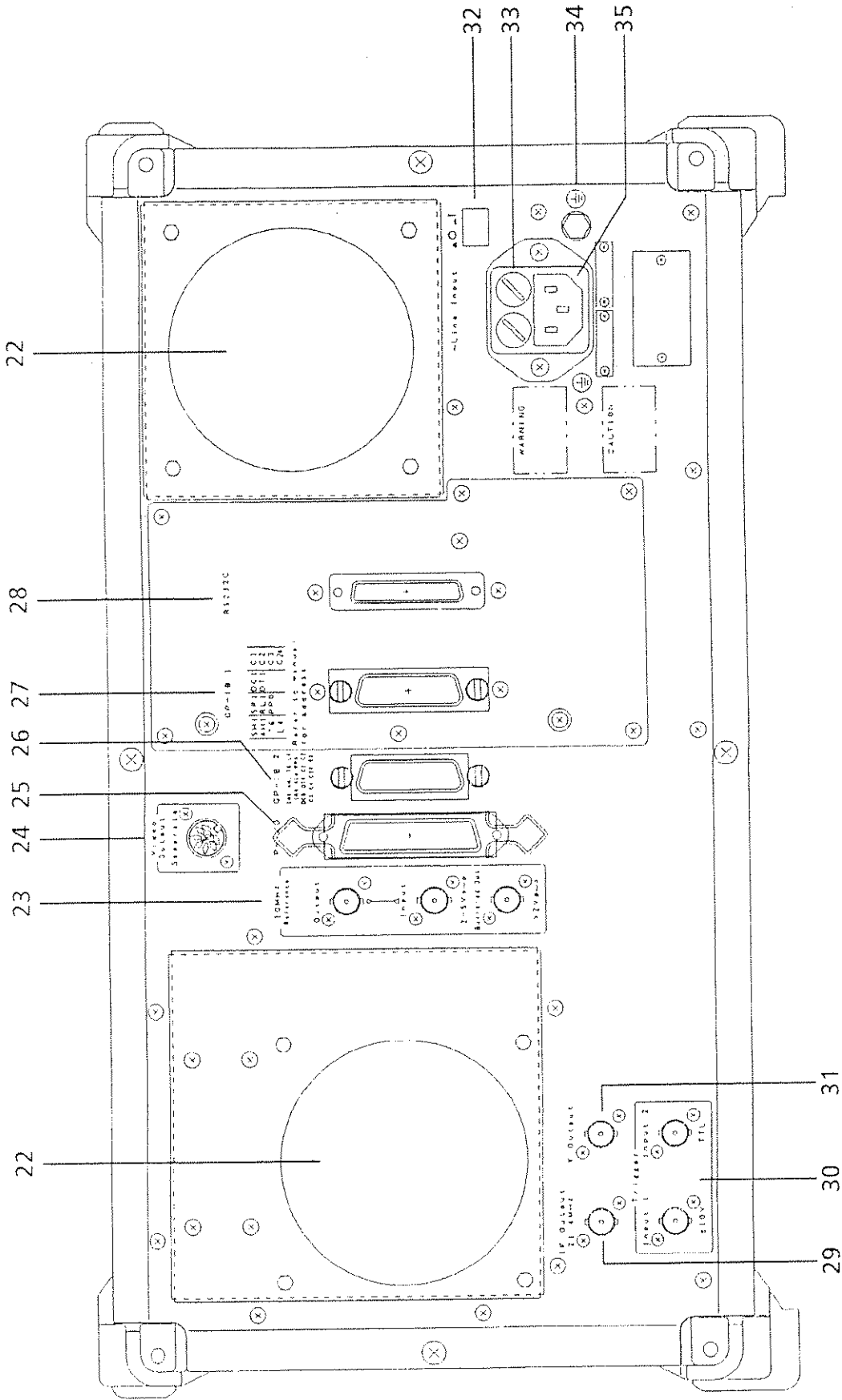

Fig. 3-2 Rear Panel

3.2 Overview of Operation

3.2.1 Overview of functions

The functions of the MS8604A are divided into the following two groups:

- Transmitter test ... TX Test mode

The following measurements are carried out using the function menu displayed on the screen.

Modulation analysis : Carrier frequency, carrier frequency error, vector error, RMS/10 symbols/maximum value, amplitude error, phase error, origin offset, droop factor, bit rate, bit rate error, constellation

RF power (with burst amplitude, rating line template) :
Slot, frame, rising edge, falling edge

Occupied frequency bandwidth

Adjacent channel leakage power

Spurious emissions (including harmonics)

Power meter (*Note:* Measures the average power.)

- Spectrum Operates as a spectrum analyzer with frequency and time domains.

The following functions are added to these two functions:

- Save/recall
In TX Test mode, the measurement conditions can be saved to the MS8604A internal memory and PMC (Plug-in Memory Card) or external MC8104A Data Storage Unit (option) PMC and FD (3.5 inch floppy disk) and can be recalled with one touch.
In spectrum mode, the waveform data can be saved, as well as the the measurement conditions.
- Copy
Outputs the measured results to an external printer.
- GPIB (Standard)
Remotely controls the MS8604A.
- PTA (Standard)
MS8604A operation can be programmed without an external controller using Anritsu's original PTA language (PTL).
- Parallel I/O port (Standard)
Effective when PTA is operated.
PTA controls external devices with a parallel I/O interface.
- RS-232C (Option)
Controls external devices with an RS-232C interface. (When PTA operated)
- IQ signal input (Option)
IQ baseband signal can be analyzed.

3.2.2 Overview of operation

Operation begins from selection of the measurement mode (TX Test/Spectrum) by pressing the front panel Main Function [TX Test]/[Spectrum] key.

The screen menu is then read and the desired item is selected with the front panel Cursor keys. The candidate values table of that item is displayed at the bottom of the screen and the desired value is selected with the Step/Select key or the rotary knob. Numeric data is input by ten-key pad and unit key (or [Enter] key). For setting and selection by function key, the desired function key [F1] to [F6] is pressed.

Most operations are carried out by function key. The screen composition is outlined below.

(Operation is described in detail in Section 4. The screens and setup items and function keys flow diagram for each screen are summarized in Appendix A Screens and Function Keys Transition Diagram.)

Overview of screens

- TX Test mode

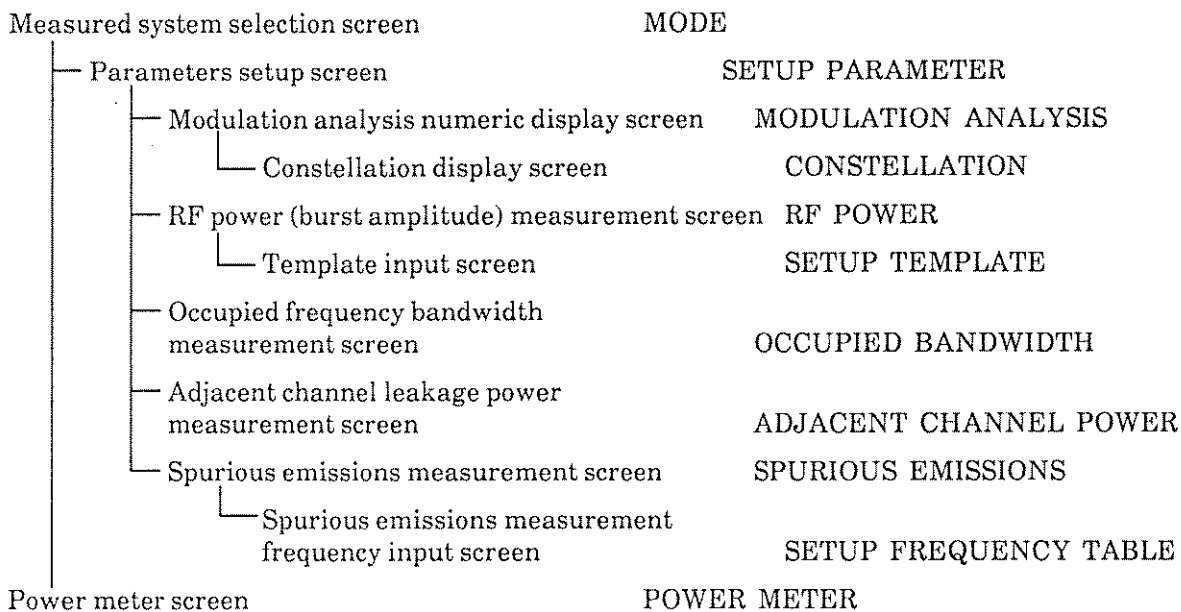

- Spectrum mode

Frequency axis (spectrum) screen TRACE-FREQ (frequency domain)

Time axis screen TRACE-TIME (time domain)

In addition to the screens given above, there are also setup and system parameters, measurement frequency, title, save contents directory and other character and numeric data input screens and table display screens.

SECTION 4 OPERATION

This section describes the MS8604A Digital Mobile Radio Transmitter Tester manual operation. For a description of GPIB remote operation and PTA operation, refer to the separate GPIB Remote Control and PTA manuals.

TABLE OF CONTENTS

4.1	Turning on the Power	4-3
4.2	Screen Descriptions	4-4
4.2.1	TX Test mode screen	4-4
4.2.2	Spectrum mode screens	4-7
4.3	Transmitter Test --- TX Test Mode	4-8
4.3.1	Preparations	4-8
4.3.2	System standard selection (MODE)	4-11
4.3.3	Parameter setting and measurement item setting (SETUP PARAMETER)	4-12
4.3.4	Modulation analysis (MODULATION ANALYSIS)	4-23
4.3.5	Power measurement (RF POWER)	4-29
4.3.6	Occupied frequency bandwidth measurement (OCCUPIED BANDWIDTH)	4-38
4.3.7	Adjacent channel leakage power measurement (ADJACENT CHANNEL POWER) ..	4-41
4.3.8	Spurious emissions measurement (SPURIOUS EMISSIONS)	4-45
4.3.9	Power meter (POWER METER)	4-50
4.4	Spectrum Analyzer Function ··· SPECTRUM mode	4-55
4.4.1	Outline of setting	4-55
4.4.2	Frequency domain or time domain selection (TRACE FREQ/TIME)	4-56
4.4.3	Frequency setting	4-58
4.4.4	Automatic tuning (AUTO TUNE)	4-61
4.4.5	Level setting	4-62
4.4.6	Frequency domain display mode and detection mode setting	4-66
4.4.7	Time domain delay time, time span, expansion mode, and display mode setting	4-70

TABLE OF CONTENTS (Cont')

4.4.8	Zone marker sweep, input signal tracking, input signal gate, and sweep trigger signal setting (SWEEP/GATE/TRIG)	4-74
4.4.9	Resolution bandwidth (RBW), video bandwidth (VBW), sweep time (SWT), and RF input attenuator (ATTEN) setting	4-86
4.4.10	Marker setting (MARKER)	4-92
4.4.11	FM modulation signal and external trigger signal waveform monitor (FM/TRIG MONITOR)	4-103
4.4.12	AM/FM demodulated signal sound monitor (SOUND)	4-106
4.4.13	Parameters setting list display (PARAMETER)	4-108
4.4.14	System setting (SYSTEM)	4-110
4.4.15	Calibration (CAL)	4-111
4.5	System Setting (SYSTEM SETUP)	4-113
4.5.1	Overview of setting	4-113
4.5.2	Data file setting	4-113
4.5.3	Alarm tone setting	4-118
4.5.4	RF input connector setting	4-118
4.5.5	GPIB address setting	4-119
4.5.6	RS-232C setting (Option)	4-120
4.6	Save/Recall	4-121
4.7	Copy	4-123
4.8	Initialization	4-124
4.9	GPIB Remote Reset	4-124
4.10	PTA Setting	4-124
4.11	I/Q Input (Option)	4-124

4.1 Turning on the Power

Turn on the power in order of the following steps:

Step	Key operation	Description			
1	Check that the power line voltage is the value specified and that the frame is grounded. (See paragraphs 2.2 and 2.3.)				
2	Rear panel <table border="1" style="display: inline-table; vertical-align: middle;"> <tr> <td>Line Input</td> </tr> <tr> <td>On/</td> </tr> <tr> <td>Off</td> </tr> </table>	Line Input	On/	Off	Power is supplied to the reference crystal oscillator only. The front panel power switch Standby lamp lights. The reference crystal oscillator is stabilized by letting the MS8604A warm up in this state for at least 30 minutes.
Line Input					
On/					
Off					
3	Front panel power switch	The front panel power switch On lamp lights. Power is supplied to all the circuits.			

When the power is turned on, the MS8604A returns to its state immediately before the power was turned off.

To initialize the panel settings, press the [Preset] key separately. (See paragraph 4.8.)
Setup begins from here.

Note: If a power failure occurs, after the power recovers, the MS8604A returns to its state immediately before the power failed.

4.2 Screen Descriptions

The state of the screen changes according to the settings. The common items are described here.

4.2.1 TX Test mode screen

(1) Screen layout

The composition of the measurement screen is described here.

- Title display area

The type MS8604A, date and time, and user-defined title are displayed on the top left line.

- Screen name display area

The screen name (paragraph 3.2) and specification name (PDC, etc.) are displayed on the second line from the top left.

- Measurement error messages display area

Messages for errors generated during measurement are reverse displayed on the third line from the top left. There are five measurement error messages as follows. These messages are shown in high priority order.

INPUT LEVEL OVER	RF input level exceeded the hardware limit.
LEVEL OVER	Level too high
LEVEL UNDER	Level too low
SIGNAL ABNORMAL	Measurements cannot be carried out.
SYNC (or UNIQUE) WORD NOT FOUND	Sync word cannot be detected.

Other error messages are:

POWER SENSOR ABNORMAL	Power sensor abnormal (power meter screen only)
SET FREQUENCY TABLE	Spurious measurement frequency not input (Spurious measurement screen only)

- Measurement mode display area

The measurement mode is displayed on the first line from the top center.

Measure : CONTINUOUS	Continuous measurement
Measure : SINGLE	Single (one time) measurement

- Measurement method display area

The measurement method is displayed on the second line from the top center.

Method : STANDARD	Measurement almost conforming to RCR standard
STD (ALL)	
STD (SEPARATE)	
Method : SPECTRUM	Measurement by spectrum analyzer
Method : HIGH SPEED	High-speed measurement by FFT (high-speed Fourier transformation) or digital filter.

- Average number of processings display area

The specified average number of processings during average value measurement is displayed on the third line from the top center.

Average : ** (* * : Number of processings)

- Menu display area

The titles of up to six function keys are displayed at the right side.

- Set value, directory, and measured result display area

The set value, directory, measured result, etc. are displayed in the center of the screen, depending on the state at that time.

- Communication area (CMA)

The value keyed in during character or numeric data input is displayed. The value is validated by pressing the unit key or [Enter] key.

At item selection input setting, all the menu items are displayed and the desired item is selected with the Step/Select [∨] [∧] keys or the rotary knob. When the [∧] key is pressed or the rotary knob is turned clockwise, the menu items move to the right and when the [∨] key is pressed or the rotary knob is turned counterclockwise, the menu items move to the left and are validated.

Error messages generated during data input and ERROR and WARNING messages generated during CAL are also displayed here. (See Appendix C.)

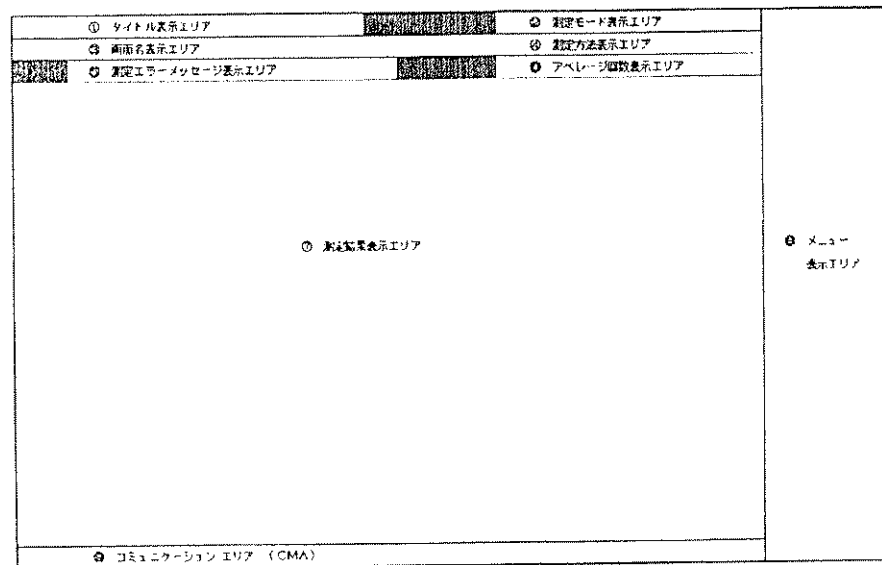

(2) Cursor

- The cursor is reverse displayed and shows the setting position. However, the cursor is not displayed in GPIB remote mode.

(3) Function keys

- The following symbols may appear in the function key display frame.
 - * : Shows that a lower level function key is displayed when this function key is pressed.
 - : Shows that the screen is changed by pressing this function key.
- The two selection items shown on the key label are selected alternately by function key.
- The double frame shows that the items on the label in the frame are selected.
- For function keys with an ENTRY frame, when data is input and validated, that value is displayed at the key label.

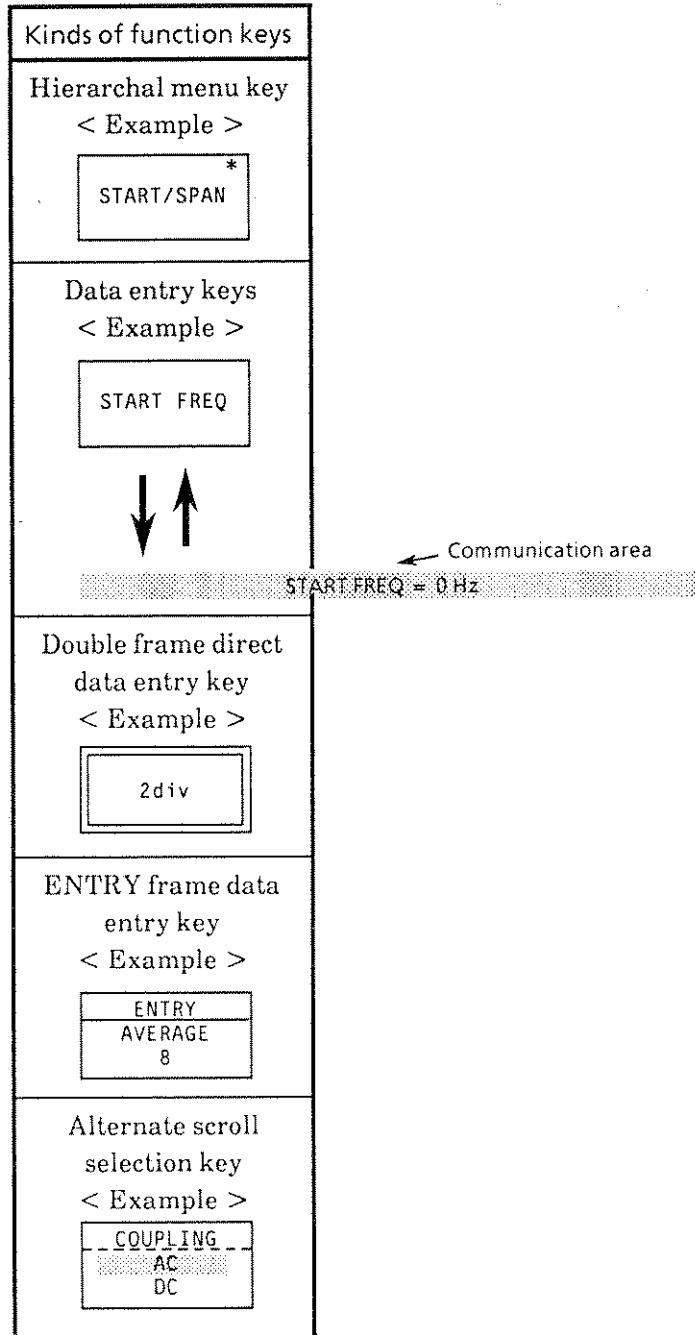

4.2.2 Spectrum mode screens

(1) Screen layout

The composition of the measurement screen is described here.

- Set value and measured value display area

The marker MKR frequency and level, RF input attenuator attenuation AT, resolution bandwidth RB, video bandwidth VB, sweep time ST, reference level RLV, detection mode (frequency domain only F:) positive peak detection POS, negative peak detection NEG, instantaneous value detection SMP, and single sweep SGLSWP are displayed at the top of the screen.

During AT, RB, VB, and ST manual setting, # is displayed at the end.

For independent setting INDEPENDENT in the frequency and time domain modes, in the time domain mode, RB and VB are displayed as RBt and VBt.

- Trace display area

One spectrum (frequency domain) or level (time domain) trace is displayed on the scale at the center of the screen.

In frequency domain mode, freq is displayed at the top right of the scale and in time domain mode, time (expanded mode time-EXP) is displayed at the top right of the scale.

In frequency domain mode, start frequency START and stop frequency STOP or center frequency CENTER, frequency SPAN, trigger TRIGGERED, and the frequency band 0 to 2 GHz: BAND 0/1.7 to 7.5 GHz: BAND 1/6.5 to 8.5 GHz: BAND 1+ are displayed at the bottom of the scale. In time domain mode, delay time DELAY, time span TIME SPAN, and frequency FREQ are displayed at the bottom of the scale.

- Menu display area

The titles of up to six function keys that can be operated at that time are displayed at the right side.

(2) Function keys

The functions keys are displayed in the same format as the TX Test mode.

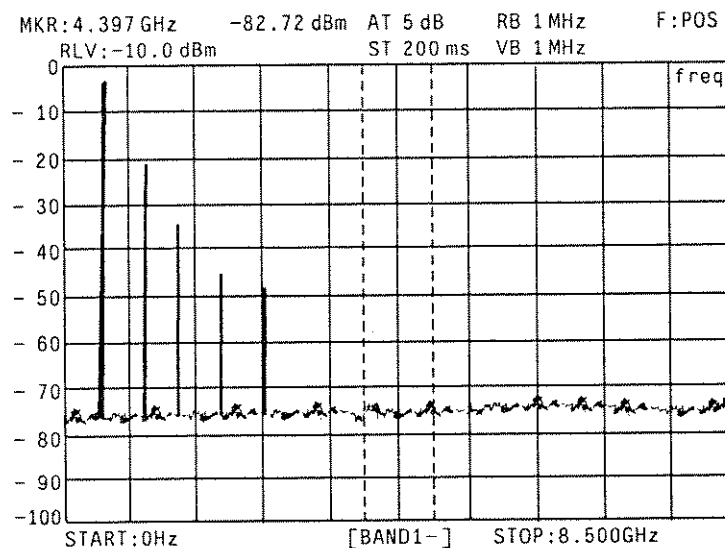

4.3 Transmitter Test - - - TX Test Mode

This paragraph describes operation when conducting transmitter tests.

4.3.1 Preparations

This paragraph describes the settings and preparations (power meter calibration and spectrum analyzer calibration) when conducting transmitter tests.

(1) Setup

When conducting transmitter tests, set the MS8604A and transmitter under test TX as shown below.

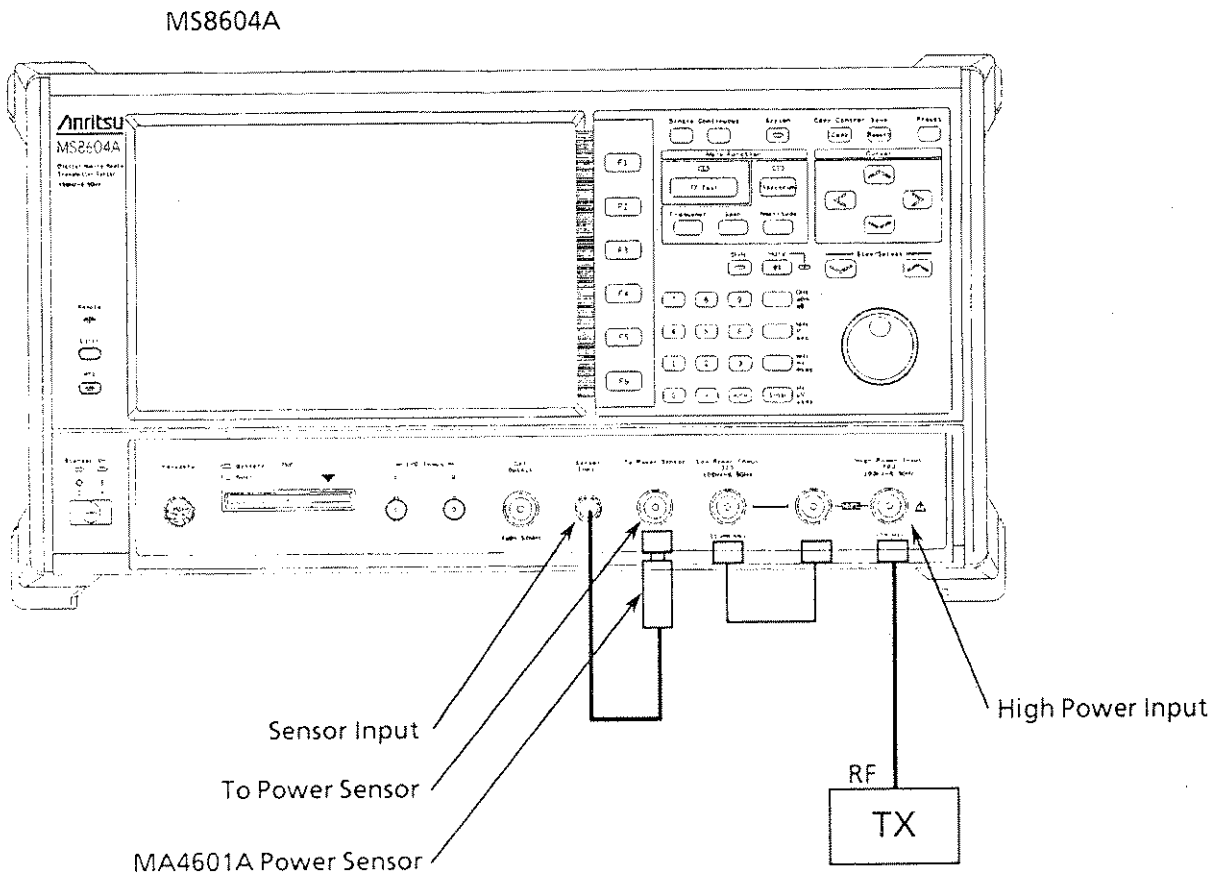

(2) Power meter calibration

To make accurate power measurements in TX Test mode, calibrate the power meter as described below.

Step	Key operation	Description
1	[TX Test]	Sets the MS8604A to TX Test mode and displays the measured system menu screen MODE.
		<i>Note:</i> When the system measurement setup parameter screens are displayed, press [BACK SCREEN] to leave the screens.
2	[etc] [F6] [F6] [POWER METER] [F5]	The POWER METER screen appears.
3	[CALIBRATION] [F4] [CAL FACTOR] [F1] [SENSOR] [F1] [BACK SCREEN] [F6]	The input screen of SENSOR CAL FACTOR is displayed. Input CAL FACTOR displayed at the MA4601A sensor.
4	[USER] [F2]	Perform when USER CAL FACTOR is used. Input the connection cable loss, etc. correction value.
5		Remove the sensor from the To Power Sensor connector not to input.
6	[RETURN] [F6] [ZERO SET] [F5]	Zero calibrates the sensor.
7		Connect the sensor to the Cal Output connector (0 dBm, 50 MHz).
8	[CAL ADJUST] [F4]	Calibrates the sensor.
9		Connect the sensor to the To Power Sensor connector.
10	[RETURN] [F6] [RETURN] [F6] [BACK SCREEN] [F6]	Ends the POWER METER screen. The measured system selection screen MODE appears.

(3) Spectrum analyzer calibration

To make accurate measurements (occupied frequency bandwidth, adjacent channel leakage power, spurious measurement) with a spectrum analyzer in TX Test mode, calibrate the spectrum analyzer as described below.

Step	Key operation	Description
1	Spectrum	Displays the first page of spectrum mode SPECTRUM function keys menu.
2	[etc] F6	Displays the second page of the SPECTRUM function keys menu.
3	[CAL] F4	Displays the CAL function keys menu.
4	[ALL] F1	Internally calibrates the spectrum analyzer.
5	TX Test	Ends the spectrum analyzer screen and sets the MS8604A to TX Test mode.

4.3.2 System standard selection (MODE)

When the front panel [TX Test] key is pressed, the measured system selection screen MODE shown below is displayed.

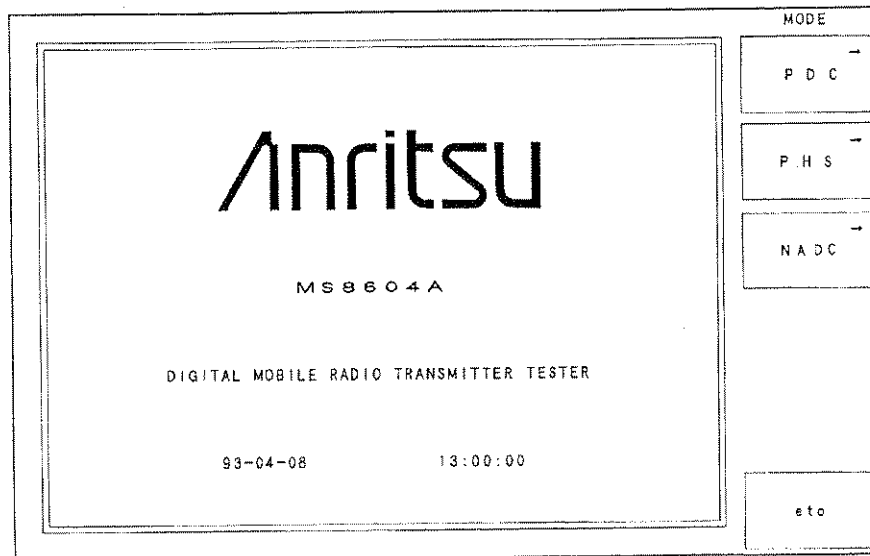

PDC : Personal Digital Cellular
 PHS : Personal Handy phone System
 NADC : North American Digital Cellular

When the system specification is selected from the function keys menu, the parameter setup screen SETUP PARAMETER corresponding to the specification is displayed.

When the [etc : F6] key is pressed from the MODE function keys menu, page 2 is displayed. When the [POWER METER : F5] key is pressed, the POWER METER screen is displayed and power can be measured. (See paragraph 4.3.9.)

4.3.3 Parameter setting and measurement item setting (SETUP PARAMETER)

After setting the parameters described in item (1) below at the SETUP PARAMETER screen, select the measurement item from the function keys menu

modulation analysis	[MODULATION ANALYSIS : F1]	(paragraph 4.3.4)
power	[RF POWER : F2]	(paragraph 4.3.5)
occupied bandwidth	[OCCUPIED BANDWIDTH : F3]	(paragraph 4.3.6)
adjacent channel power	[ADJACENT CHANNEL POWER : F4]	(paragraph 4.3.7)
spurious emission/harmonic	[SPURIOUS EMISSIONS : F5]	(paragraph 4.3.8)

and perform measurement.

MS8604A 93-07-14 18:35:21 III		PDC
-- SETUP PARAMETER (PDC) --		
INPUT	Terminal : RF RF level : 30 dBm	MODULATION ANALYSIS
SIGNAL	Measuring object : MS-COM (Ramp up symbol point = 2, Number of symbols = 135) Channels per carrier : 3 (FULL RATE)	RF POWER
FREQUENCY	Channel & Frequency : 1001 CH = 940.025 000 MHz Channel spacing : 25.000 kHz	OCCUPIED BANDWIDTH
SYNC WORD	pattern : USER 0111 1000 0101 1011 0100 ----- Start point : 59	ADJACENT CHANNEL POWER
Transmit timing	: ON Band : 800MHz	SPURIOUS EMISSIONS
Root-Nyquist filter	: YES	BACK SCREEN
Symbol timing (normal=0.00)	: 0.00 symbol	
RF LEVEL : 30 dBm		

(1) INPUT

(a) Terminal

Selects the measured signal terminal Terminal.

When IQ-AC or IQ-DC is selected, modulation analysis and power and occupied frequency bandwidth (high-speed mode only) measurements can be made.

Range : RF, IQ-AC, IQ-DC . . . IQ is optional.

Initial value : RF

(b) RF Level

Inputs the input level RF Level.

RF level setting method

Sets the level of the measured signal. For continuous wave, set the average power and for burst wave, set the average power of the burst signal.

Range : -12 to 40 dBm (step : 1 dB) (RF input : High)
-32 to 20 dBm (step : 1dB) (RF input : Low)

Initial value : 30 dBm (RF input : High)
10 dBm (RF input : Low)

Note: Not displayed for IQ-**.

(2) SIGNAL

(a) Measuring object

Inputs the measuring object & physical channel Measuring object.

Range (PDC) :

MS-CONT	Mobile station (up link) control channel	Mobile Station-Control
MS-COM	Mobile station (up link) communication channel	Mobile Station-Communication
MS-SYNC	Mobile station (up link) synchronization burst	Mobile Station-Synchronization
BS-CONT	Base station (down link) control channel	Base Station-Control
BS-COM	Base station (down link) communication channel	Base Station-Communication
BS-SYNC	Base station (down link) synchronization burst	Base Station-Synchronization

Initial value (PDC) : MS-COM

Range (PHS) :

PS-CONT	Personal station (up link) control channel	Personal Station-Control
PS-COM	Personal station (up link) communication channel	Personal Station-Communication
CS-CONT	Cell station (down link) control channel	Cell Station-Control
CS-COM	Cell station (down link) communication channel	Cell Station-Communication

CONTINUOUS Continuous wave

Initial value (PHS) : PS-COM

Range (NADC) :

MOBILE	Mobile station (up link)	Mobile Station Standard Burst
SHORTENED BURST	Mobile station (up link)	Mobile Station Shortened Burst
BASE	Base station (down link)	Base Station Base

Initial value (NADC) : MOBILE

PDC

When MS-*** is selected, signals with one burst in one frame become the measurement objective.

When BS-*** is selected, continuous wave signals become the measurement objective.

When measuring continuous wave signals modulated by PN, etc., select BS-***.

PHS

When PS-*** is selected, signals with one burst in one frame become the measurement objective.

When CS-*** is selected, signals with one or more CS's in the slots 1 to 4 in one frame become the measurement objective.

NADC

When MOBILE or SHORTENED BURST is selected, signals with one burst in one frame become the measurement objective.

When BASE is selected, continuous wave signals become the measurement objective.

(b) Ramp up symbol point

The rising edge symbol position Ramp up symbol point is set as shown below according to the Measuring object.

PDC:

Measuring object	Ramp up symbol point
MS-CONT	2
MS-COM	2
MS-SYNC	29
BS-CONT	2
BS-COM	2
BS-SYNC	2

PHS: 2

NADC:

Measuring object	Ramp up symbol point
MOBILE	6
SHORTENED BURST	6
BASE	—

(c) Number of symbols

The number of analysis symbols Number of symbols is set as shown below according to the Measuring object.

PDC :

Measuring object	Number of symbols
MS-CONT	129
MS-COM	135
MS-SYNC	72
BS-CONT	138
BS-COM	138
BS-SYNC	138

PHS : 110

NADC:

Measuring object	Ramp up symbol point
MOBILE	156
SHORTENED BURST	134
BASE	162

(d) Channels per carrier

Selects the number of channels per carrier. Does not apply to PHS.

Range : 3 (FULL RATE), 6 (HALF RATE)

Initial value : 3 (FULL RATE)

(3) FREQUENCY

(a) Channel & Frequency

Inputs the channel number and frequency Channel & Frequency.

(i) Channel No.

Range: 0 to 9999 (step : 1)

Initial value: 1001 (PDC/PHS), 1 (NADC)

(ii) Frequency

Range: 100 Hz to 8.5 GHz (step : 1 Hz)

Initial value: 940.025 000 (PDC), 1895.150 000 (PHS), 825.030 000 (NADC)

(b) Channel spacing

Inputs the frequency spacing Channel spacing.

Range : - 2 MHz to 2 MHz (step : 1 Hz)

Initial value : 25.000 kHz (PDC), 300.000 kHz (PHS), 30.000 kHz (NADC)

Note: When the channel number is changed, the frequency corresponding to the channel spacing changes also. However, the channel number does not change if the frequency is changed. The others do not change even if the channel spacing is changed.

(4) SYNC WORD --- PDC/NADC, UNIQUE WORD --- PHS

(a) Pattern

Selects, or inputs, the synchronization word pattern.

Range (PDC) :

NO, USER, S1 to S12, SS1 to SS6,

S1 to S12 and SS1 to SS6 are limited by the Measuring object. The following ranges can be selected.

Measuring object	Selectable Pattern
MS-CONT	S1 to S12
MS-COM	S1 to S12
MS-SYNC	SS1 to SS6
BS-CONT	S1 to S12
BS-COM	S1 to S12
BS-SYNC	SS1 to SS6

Synchronization word pattern details are shown below.

Item	Name
BS-CONT BS-COM 20 bits (down link)	S 1 = 87A4B S 2 = 9D236 S 3 = 81D75 S 4 = A94EA S 5 = 5164C S 6 = 4D9DE S 7 = 31BAF S 8 = 1E56F S 9 = E712C S 10 = FBC1F S 11 = 8279E S 12 = 98908
BS-SYNC 32 bits (down link)	SS1 = 2F94D06B SS2 = 1D4EE2B1 SS3 = 70168FE9 SS4 = 83527CAD SS5 = 3678C987 SS6 = 48D8B727
MS-CONT MS-COM 20 bits (up link) (down link bit reversal)	S 1 = 785B4 S 2 = 62DC9 S 3 = 7E28A S 4 = 56B15 S 5 = AE9B3 S 6 = B2621 S 7 = CE450 S 8 = E1A90 S 9 = 18ED3 S 10 = 043E0 S 11 = 7D861 S 12 = 676F7
MS-SYNC 32 bits (up link) (down link bit reversal)	SS1 = D06B2F94 SS2 = E2B11D4E SS3 = 8FE97016 SS4 = 7CAD8352 SS5 = C9873678 SS6 = B72748D8
User definition	USER 2 to 32 bits arbitrary combination of "0" and "1". (Step: 2 bits)
No synchronization word	NO

When NO is selected, synchronization word setting and detection are disabled.

When USER is selected, the user can set an arbitrary pattern. A binary image display line for user pattern input is displayed.

Input the pattern as shown below.

[Synchronization word user pattern setting]

Step	Key operation	Description
1	Cursor <input type="button" value="↑"/> <input type="button" value="↓"/>	Moves the cursor to the binary image display line for user pattern input.
2	Cursor <input type="button" value="←"/> <input type="button" value="→"/>	Specifies the 4-bits at which the pattern is to be set. (The cursor moves to the left and right in 4-bit steps.)
3	<input type="button" value="0"/> , <input type="button" value="1"/> , <input type="button" value="BS"/> , <input type="button" value="+/-"/>	Input the 4-bit data (or 2-bit data) while watching the binary image displayed in the communication area (CMA).
4	<input type="button" value="Enter"/>	Validate the 4-bit data.
5	Set the next 4-bit data by repeating steps 2 to 4.	

- Notes:
1. If the [BS] key is pressed during data input, the character at the right end of the data displayed in the CMA is cleared.
 2. If - is set by [+/-] key, succeeding bits are invalid and -- ---- is displayed.
 3. If only two bits are set, succeeding bits are invalid and -- ---- is displayed.
 4. One and three bits data cannot be set.
 5. For data of five or more bits, only the first four bits are set.
 6. A synchronization word up to 32 bits long can be set by left-justified continuous pattern.

Range (PHS) :

NO, USER, 32 bit, 16 bit

32 bit and 16 bit are limited by the Measuring object. The following ranges can be selected:

Measuring object	Selectable Pattern
PS-CONT	32 bit = 6B899AF0
PS-COM	32 bit = 6B899AF0 16 bit = E149
CS-CONT	32 bit = 50EF2993
CS-COM	32 bit = 50EF2993 16 bit = 3D4C

NO, USER, synchronization word user pattern setting, etc. are the same as PDC.

Range (NADC) :

NO, USER, Sync 1 to Sync 6

Synchronization word patterns Sync 1 to Sync 6 details are given below.

Sync 1 = A91DE4A

Sync 2 = A9D127A

Sync 3 = C7E3C0C

Sync 4 = 342C3F3

Sync 5 = 13E23D1

Sync 6 = DC2EC1D

NO, USER, synchronization word user pattern setting, etc. are the same as PDC.

Initial value : S1 = 785B4 (PDC)

16 bit = E149 (PHS)

Sync 1 = A91DE4A (NADC)

(b) Start point

Inputs the synchronization word start position Start point.

Range (PDC) :

Can be input only when SYNC WORD Pattern is USER.

When SYNC WORD Pattern is USER, the setting range becomes as follows according to the Measuring object:

Measuring object	Start point (step : 1)
MS-CONT	2 to (131 - X)
MS-COM	2 to (137 - X)
MS-SYNC	29 to (101 - X)
BS-CONT	2 to (140 - X)
BS-COM	2 to (140 - X)
BS-SYNC	2 to (140 - X)

(X = Number of synchronization word symbols)

Note: When a Measuring object setting change makes the current set value no good, the initial value is set.

Range (PHS) :

Can be input only when UNIQUE WORD Pattern is USER.

When UNIQUE WORD Pattern is USER, the setting range becomes as follows according to the Measuring object:

Measuring object	Start point (step : 1)
PS-CONT	2 to (112 - X)
PS-COM	2 to (112 - X)
CS-CONT	2 to (112 - X)
CS-COM	2 to (112 - X)
CONTINUOUS	Cannot be input

(X = Number of synchronization word symbols)

Note: When a Measuring object setting change makes the current set value no good, the initial value is set.

Range (NADC) :

Can be input only when SYNC WORD Pattern is USER.

When SYNC WORD Pattern is USER, the setting range becomes as follows according to the Measuring object:

Measuring object	Start point (step : 1)
MOBILE	6 to (156 - X)
SHORTENED BURST	6 to (134 - X)
BASE	0 to (162 - X)

(X = Number of synchronization word symbols)

Note: When a Measuring object setting change makes the current set value no good, the initial value is set.

Initial value : 59 (PDC), 6 (PHS), 14 (NADC)

Ramp up symbol point, Number of symbols, and SYNC WORD (UNIQUE WORD) Start point are described with a PDC mobile station (up link) communication channel MS-COM as an example.

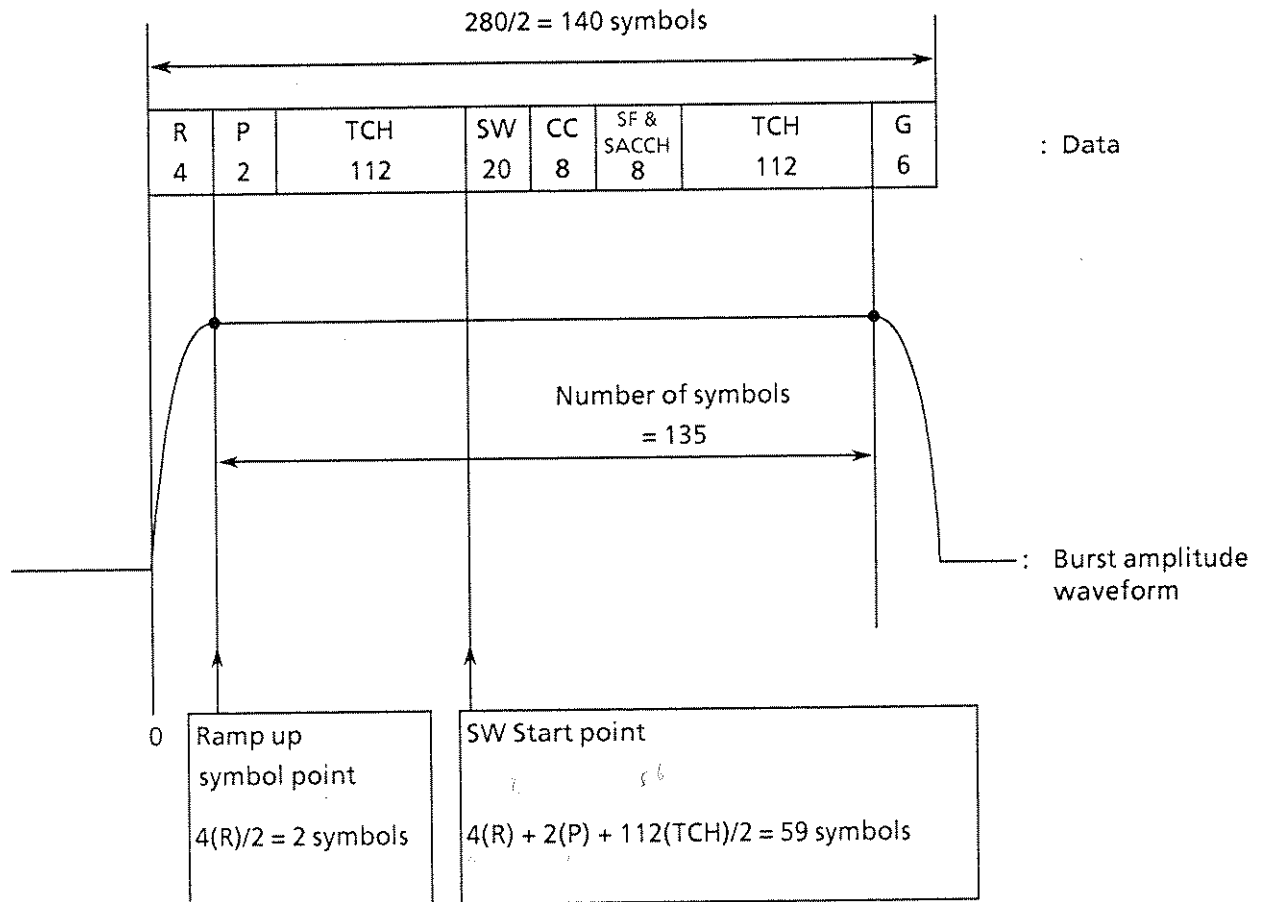

Ramp up symbol point, Number of symbols, and SYNC WORD (UNIQUE WORD) are used on the modulation and power measurement screens.

(5) Root-Nyquist filter

Selects the MS8604A receive filter at modulation analysis measurement. When NO is selected, the receive filter characteristic becomes flat.

Range: NO, YES

Initial value: YES

(6) Symbol timing

Used when a symbol timing in the MS8604A is changed in modulation analysis and RF power measurement.

Range: -0.20 to +0.20 (step: 0.01)

Initial value: 0.00

(7) Transmit timing (PDC)

Set ON/OFF of transmission timing measurement.

Range: OFF, ON

- Notes:
1. Can be set when the Measuring object is BS-*** and SYNC WORD is other than NO or USER.
 2. The transmission timing of the mobile station for the base station can be measured by setting to ON.

(8) Band (PDC)

When measuring the transmission timing, set the system frequency band.

800 MHz : 800 MHz band
1500 MHz : 1500 MHz band

(9) SLOT (PHS)

(a) CS slot number

Sets transmission of the slots to ON/OFF.

- Notes:
1. Can be set when the Measuring object is CS-***.
 2. The frequencies of the slots set to transmission ON should be the same.

(b) active (PHS)

Sets the slot No. of analysis objective for the slot with CS set to transmission ON.

Range: 1 to 4

Note: Can be set when the Measuring object is CS-***.

(c) PS slot (PHS)

Sets the PS slot ON/OFF corresponding to the analysis objective slot of CS.

Range: OFF, ON

- Notes:
1. Can be set when the Measuring object is CS-*** and the UNIQUE WORD Pattern is other than NO or USER.
 2. The transmission timing of PS for the analysis objective slot of CS can be measured by setting to ON.

4.3.4 Modulation analysis (MODULATION ANALYSIS)

The modulation analysis numeric display screen MODULATION ANALYSIS shown below is entered by pressing the [MODULATION ANALYSIS: F1] key after setting the parameters at the SETUP PARAMETER screen (paragraph 4.3.3).

MS8604A 93-07-14 18:35:21 III Measure : CONTINUOUS		MOD. ANAL
-- MODULATION ANALYSIS (PDC) --		CONSTEL- LATION
FREQUENCY		10 BURST AVERAGE ON OFF
Carrier frequency	: 940.025 001 0 MHz	
Carrier frequency error	: 0.001 0 kHz	
MODULATION		CALIBRATION *
RMS vector error	: 1.35 % (rms)	
First 10 symbols RMS vector error	: 2.55 % (rms)	
Peak vector error	: 4.34 %	
Magnitude error	: 0.45 % (rms)	
Phase error	: 0.86 deg. (rms)	
Origin offset	: -45.32 dB	
Droop factor	: -0.000 2 dB/symbol	
DATA (10 burst average "ON" only)		
Bit rate	: 42.000 004 2 kbps	
Bit rate error	: 0.1 ppm	
PARAMETERS		BACK SCREEN
Frequency	: 940.025 000 MHz	
RF level	: 30 dBm	

(1) Modulation analysis

The following modulation analysis values are displayed:

- (a) FREQUENCY
 - (i) Carrier frequency
Displays the carrier frequency in MHz units (step: 0.1 Hz).
 - (ii) Carrier frequency error
Displays the carrier frequency error in kHz units (step: 0.1 Hz)
- (b) MODULATION
 - (i) RMS vector error
Displays the vector error (RMS) in % (rms) units (step: 0.01 %).
 - (ii) First 10 symbols RMS vector error
Displays the vector error (10 symbols) in % (rms) units (step: 0.01 %).
 - (iii) Peak vector error
Displays the vector error (peak) in % units (step: 0.01 %).
 - (iv) Magnitude error
Displays the magnitude error in % (rms) units (step: 0.01 %).

(v) Phase error

Displays the phase error in deg. (rms) (step: 0.01 deg. (rms)).

(vi) Origin offset

Displays the origin offset in dB units (step: 0.01 dB).

(vii) Droop factor

Displays the droop factor in dB/symbol units (step: 0.0001 dB/symbol).

(c) DATA

[Can be measured only when [10 BURST AVERAGE: F2] is ON.]

(i) Bit rate

Displays the transmission rate in kbps units (step: 0.000 000 1 kbps).

(ii) Bit rate error

Displays the transmission rate error in ppm units (step: 0.1 ppm).

(2) PARAMETERS

Displays the Frequency and RF level set at SETUP PARAMETER screen.

(3) Function keys

- [CONSTELLATION : F1]

Switches to the constellation display screen CONSTELLATION. See item (4).

- [10 BURST AVERAGE ON/OFF : F2]

Toggles between displaying the average of the measured value of 10 consecutive bursts and displaying the measured value for each burst.

When ON is selected, the Bit rate and Bit rate error measured values are displayed also.

Initial value : OFF

- [CALIBRATION : F4]

Displays the CALIBRATION function keys menu for the MS8604A internal calibration. See item (5).

- [BACK SCREEN : F6]

Returns to the high level SETUP PARAMETER screen.

(4) Constellation display

The CONSTELLATION screen is displayed by pressing the [CONSTELLATION]: F1] key for constellation display. OFF is displayed even if ON is selected at the [10 BURST AVERAGE ON/OFF: F2] key. IQ separated signal is converted to magnitude 1 (for ideal signal) orthogonal coordinates. The waveform with the origin offset removed from the measured signal is constellation displayed. The origin offset is displayed independently at the center of the coordinates. When an IQ signal is input, the waveform including the origin offset is displayed.

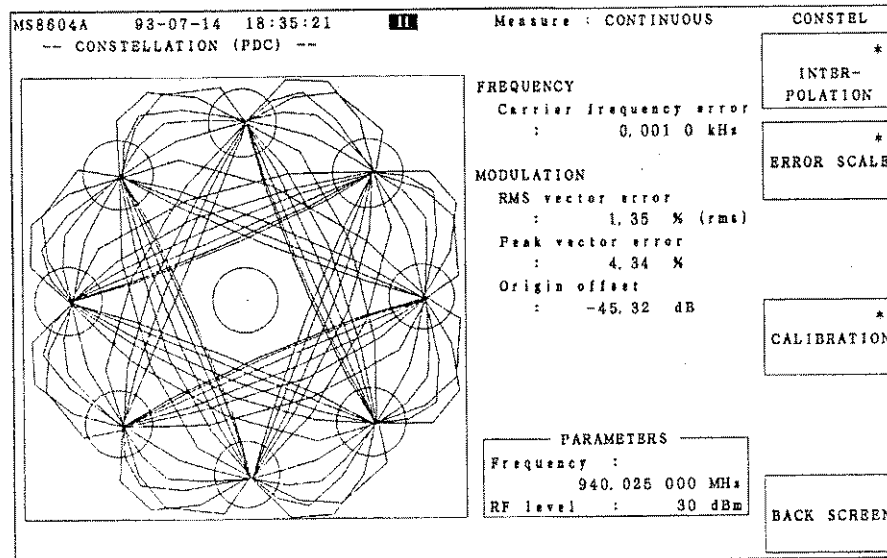

(a) Modulation analysis values

The following modulation analysis values are displayed:

- (i) **FREQUENCY** Carrier frequency error
 - Displays the carrier frequency error in kHz units (step: 0.1 Hz).
- (ii) **MODULATION**
 - **RMS vector error**
Displays the vector error (RMS) in % (rms) units (step: 0.01 %).
 - **Peak vector error**
Displays the vector error (peak) in % units (step: 0.01 %).
 - **Origin offset**
Displays the origin offset in dB units (step: 0.01 dB).

(b) PARAMETERS

Displays the Frequency and RF level set on the SETUP PARAMETER screen.

(c) Function keys

- **[INTERPOLATION : F1]**
Displays the following INTERPOLATE function keys menu for selecting constellation display interpolation mode. Initial value: NON
 - [NON : F1]** Selects no interpolation mode. (Symbol points are displayed by dots.)
 - [LINEAR : F2]** Selects linear interpolation mode.
(Symbol points are connected by a straight line.)
 - [4 POINT : F3]** Selects four points interpolation mode. (Space between symbol points is curve interpolated and connected at four points.)
 - [RETURN]** Returns to the high level CONSTEL function keys menu.

(i) NON-INTERPOLATION

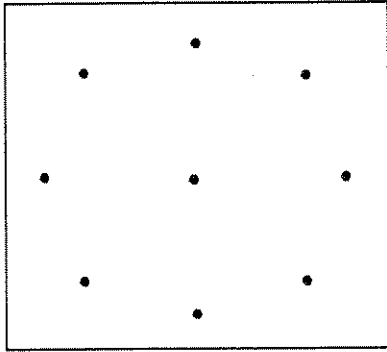

- Selects no interpolation mode.
(Symbol points are displayed by dots.)

(ii) LINEAR-INTERPOLATION

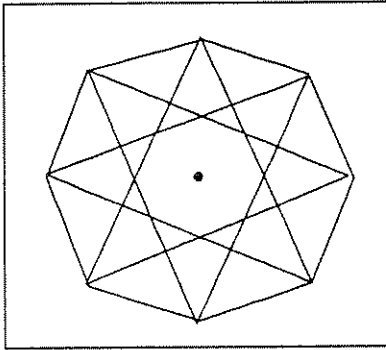

- Selects linear interpolation mode.
(Symbols points are connected by a straight line.)

(iii) 4 POINTS-INTERPOLATION

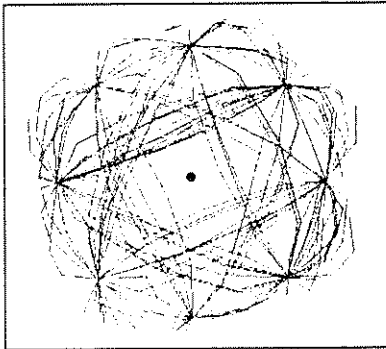

- Selects four points interpolation mode.
(Space between symbol points is curve interpolated and connected at four points.)

- [ERROR SCALE : F2]

Displays the following ERROR SCALE function keys menu for selecting magnitude 1 four symbol points and four symbol points rotated 45 degrees on the I and Q axes of the constellation display and the size of the error circle displayed at the origin. Initial value: OFF

- [5 % : F1] Displays a 5 % error circle.
- [10 % : F2] Displays a 10 % error circle.
- [20 % : F3] Displays a 20 % error circle.
- [OFF : F4] Clears the error circle.
- [OFFSET 0/22.5 : F5] Switch the angle of the error circle for the I and Q axes.
- [RETURN : F6] Returns to the high level CONSTEL function keys menu.

If the [ERROR SCALE: F2] key is pressed when OFF is selected, 5 % is selected.

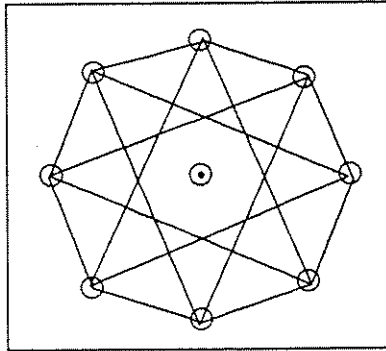

- [CALIBRATION : F4]

Displays the CALIBRATION function keys menu for the MS8604A internal calibration.
See item (5).

- [BACK SCREEN : F6]

Returns to the high level MODULATION ANALYSIS modulation analysis numeric display screen.

(5) Calibration

The following CALIBRATION function keys menu is displayed by pressing the [CALIBRAT: F4] key for MS8604A internal calibration.

- [AUTO RANGE : F1]

Automatically executes the following two internal processings:

- ① The MS8604A internal RF ATT, A/D input level optimization
- ② Calibration of the power measurement value at DSP by the power meter (Reflects the USER CAL FACTOR value of the power meter and calibrates).

Auto Range executes internal processing common to all the measurement screens. Therefore, if it is executed on one measurement screen, it does not have to be executed on the other measurement screens.

When the MS8604A internal temperature rises or the ambient temperature changes, or when the measurement frequency is changed, the calibration value changes. Thus, if an accurate measurement transmitter power is required absolute value, execute the Auto Range function again.

When the RF level is changed at the parameter setting screen SETUP PARAMETER or Preset is executed by pressing the Preset key, the correction value becomes 0 (clear).

Notes : 1. When signals other than Frequency of the parameter setting screen SETUP PARAMETER is input simultaneously, Auto Range is not executed correctly.

2. When the Frequency of the parameter setting screen SETUP PARAMETER is less than 10 MHz, Auto Range is not executed.

3. When the input level of the MS8604A is extremely small (when the input signal frequency deviates extremely from the setting frequency or no input, for example), both ① and ② may not be executed. In this case, 504 Auto range abort is displayed at the communication area (CMA), lower part area in the screen.

4. ② is executed only when the power sensor is connected to the MS8604A. When the average input level of the power sensor is less than 1 μ W or over 110 mW, ② is not executed. When only ② is not executed, W605 Power calibration abort is displayed at the communication area (CMA), the lower part in the screen.

- [FREQUENCY ADJUST : F2]

If the frequency shift of the unknown signal is large (PDC/NADC: when the shift is ± 1 kHz or more, PHS: when the shift is ± 10 kHz or more), accurate measurements cannot be made.

In this case, execute the Frequency Adjust function.

The Frequency Adjust range is up to ± 50 kHz for PDC/NADC and up to ± 400 kHz for PHS.

Frequency Adjust executes internal processing common to all the measurement screens. Therefore, if it is executed for one measurement screen, it does not have to be executed for the other measurement screens.

When Frequency of the SETUP PARAMETER screen is changed, the correction value becomes 0.

When Frequency of the SETUP PARAMETER screen is changed or Preset is performed by pressing the Preset key, the correction value becomes 0 (clear).

- [RETURN : F6]

Returns to the high level MOD. ANAL function keys menu.

4.3.5 Power measurement (RF POWER)

Power measurement is entered by pressing the [RF POWER: F2] key after setting the parameters on the SETUP PARAMETER screen (paragraph 4.3.3).

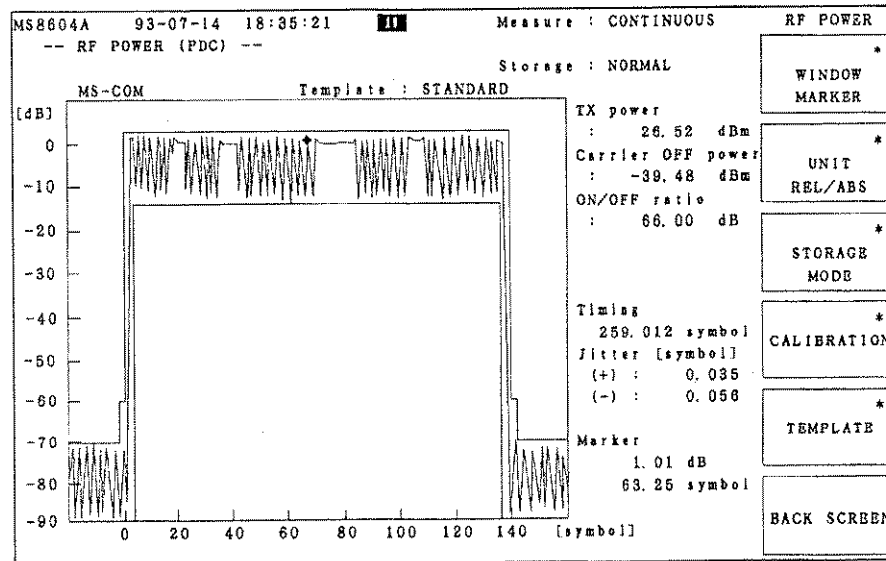

When measuring burst signals (except PDC/NADC synchronization burst), if the amplitude measurement waveform is a relative level display, a template (amplitude standard line) can also be displayed.

(1) Power measured values

The amplitude measurement waveform is displayed in a window and the following power measured values are displayed along the right side of this window.

(a) TX power

PDC : If MS-*** is selected, the average power in the burst is displayed.
If BS-*** is selected, the average power is displayed.

PHS : The average power is displayed.

NADC : If MOBILE SHORTENED BURST is selected, the average power in the burst is displayed.
If BASE is selected, the average power in 1 slot is displayed.

(b) Carrier OFF power

Displays the average power when transmission is OFF.
It is displayed when measuring burst signals.

(c) ON/OFF ratio

Displays the ON/OFF power ratio in dB units (step: 0.01 dB).

(d) Marker

Displays the marker level and position in dB or dBm units (step: 0.01 dB) and symbol units (step: 0.25 symbol), respectively.

(e) Timing

The transmission timing is displayed in symbol units (step: 0.001 symbol).

(f) Jitter

PHS : The transmission jitter is displayed in symbol units (step: 0.001 symbol).

(g) Modulation Power

PHS : The average power in the burst is displayed.

Other than PHS : Not displayed.

(2) PARAMETERS

Displays the Frequency and RF level set at the SETUP PARAMETER screen.

(3) Function keys

• [WINDOW, MARKER : F1]

Displays the following WINDOW and MARKER function keys menu for selecting the position of the amplitude measurement waveform displayed in the window or for setting the marker on the waveform. Initial value: SLOT

[SLOT : F1] Displays a slot waveform.

[FRAME : F2] Displays a frame waveform.

[LEADING : F3] Displays the rising edge waveform.

[TRAILING : F4] Displays the falling edge waveform.

[MARKER : F5] Displays the following MARKER function keys menu for setting the marker on the waveform. If the [MARKER: F5] key is pressed when OFF is selected, NORMAL is selected.
Initial value: OFF

[NORMAL : F1] Sets the marker position in symbol units (step: 0.25 symbol).
Initial value: Center

[OFF : F2] Turns off the marker.

[RETURN : F6] Returns to the high level WINDOW/MKR function keys menu.

[RETURN : F6] Returns to the high level RF POWER function keys menu.

• [UNIT, REL/ABS : F2]

Displays the following UNIT function keys menu for selecting the power measured value power units and amplitude measurement waveform relative display/absolute display.

[dBm : F1] Sets the TX power and Carrier OFF power units to dB.

[nW/ μ W/mW/W : F2] Sets the TX power and Carrier OFF power units to watts and performs switching by auto ranging.

[LEVEL REL/ABS : F5] Toggles between amplitude measurement waveform relative display and absolute display.
If measuring burst signals (except PDC synchronization burst), for relative display, a template can be displayed.
While burst is ON, displays the value of the amplitude measurement waveform relative to the average power.
Initial value: REL

[RETURN : F6] Returns to the high level RF POWER function keys menu.

- [STORAGE MODE : F3]

Displays the following STORAGE MODE function keys menu for selecting the display mode.
Initial value: NORMAL

[NORMAL : F1] Normal mode

[MAX/MIN/AVG : F2] Displays the following MAX/MIN/AVG function keys menu for selecting the maximum value, minimum value, and average value displays.

[MAX HOLD : F1] Compares the new and old data and displays the larger value for each measurement.

[MIN HOLD : F2] Compares the new and old data and displays the smaller value for each measurement.

[AVERAGE : F3] Performs average processing.
At the end of the set number of averagings, measurement stops.

Note : When AVERAGE is selected, the measurement mode becomes SINGLE. When ERROR (LEVEL OVER, LEVEL UNDER, etc.) is generated during AVERAGE, measurement stops. To resume measurement, press the [Single] or [AVERAGE: F3] key.

[ENTRY AVERAGE No. : F4] Sets the number of averagings (2 to 99).
The number of averagings can be also set in the Average OFF state.
Initial value: 4

[RETURN : F6] Returns to the high level STORAGE MODE function menu.

[CUM/OVER : F3] Displays the following CUM/OVER function keys menu for selecting dot data cumulative display (CUMULATIVE) or trace data overwriting display (OVERWRITE).

[CUMULATIVE : F1] Selects CUMULATIVE display.

[OVER WRITE : F2] Selects OVERWRITE display.

[RETURN : F6] Returns to the high level STORAGE MODE function menu.

[WIDE DYNAMIC RANGE : F5] Used when expanding the burst amplitude (power) measurement dynamic range. Switches the amplitude measurement dynamic range to 110 dB.
This function key can be selected if INPUT Terminal of the SETUP PARAMETER screen is RF, the measured signal is a burst and there is a synchronization word.

Note : When WIDE DYNAMIC RANGE is selected, the measurement mode becomes SINGLE.

[RETURN : F6] Returns to the high level RF POWER function keys menu.

Note : NORMAL, MAX-HOLD, MIN-HOLD, AVERAGE, CUMULATIVE, OVERWRITE, or WIDE-DYNAMIC-RANGE of STORAGE MODE can be selected.

- [CALIBRATION : F4]

See paragraph 4.3.4 (5).

- [TEMPLATE : F5]

Selects the displayed template (amplitude standard line). However, this function is effective only for relative level display at burst signal measurement (except PDC/NADC synchronization burst).

Displays the following TEMPLATE function keys menu:

[SELECT TEMPLATE : F1] Displays the following SELECT TEMP function keys menu for calling templates saved in the internal memories.
Initial value: STANDARD

- | | | |
|---|-----------------|---|
| [| [No.1 : F1] | Calls the user-defined template saved in internal memory 1. |
| | [No.2 : F2] | Calls the user-defined template saved in internal memory 2. |
| | [No.3 : F3] | Calls the user-defined template saved in internal memory 3. |
| | [STANDARD : F5] | Calls the template saved in internal memory. |
| | [RETURN : F6] | Returns to the high level TEMPLATE function keys menu. |

[OFF : F2] Clears the displayed template.

[SETUP TEMPLATE : F5] Displays the template input screen SETUP TEMPLATE for saving, editing, and copying templates.
See item (4).

[RETURN : F6] Returns to the high level RF POWER function keys menu.

- [BACK SCREEN : F6]

Returns to the high level SETUP PARAMETER screen.

(4) Template creation

For relative level display at burst signal measurement, a template (amplitude standard line) can be selected.

The templates consist of three user-defined templates (No.1 to No.3) stored in internal memories No.1 to No.3 corresponding to (PDC) MS-COM, MS-CONT, (PHS) ** -COM, ** -CONT, and (NADC) MOBILE and SHORTENED BURST and a STANDARD template.

The template input and creation methods are described below.

Template input screen SETUP TEMPLATE

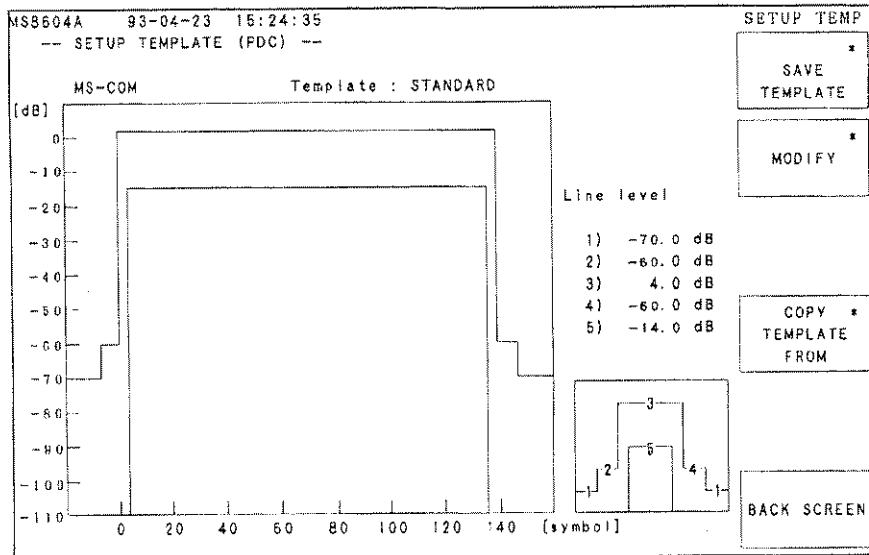

When the TEMPLATE function keys menu is displayed and the [SETUP TEMPLATE: F5] key is pressed, the SETUP TEMPLATE screen for saving, editing, and copying templates is displayed. The standard line level Line level 11 to 5 is displayed in dB units (step: 0.1 dB). At this time, the following SETUP TEMP function keys menu is displayed. When the template is modified, Template: name becomes NOT SELECTED to show that a template is not saved in internal memory.

- [SAVE TEMPLATE : F1]

Displays the SAVE TEMP function keys menu for saving the displayed template.

- [No.1 : F1] Saves the displayed template to internal memory 1.
- [No.2 : F2] Saves the displayed template to internal memory 2.
- [No.3 : F3] Saves the displayed template to internal memory 3.
- [RETURN : F6] Returns to the high level SETUP TEMP function keys menu.

• [MODIFY : F2]

Displays the following MODIFY function keys menu for modifying the displayed template. The selected LIMIT line is highlighted.

- [LIMIT-1 : F1] Modifies the displayed template standard line level Line level 1 in dB units (step: 0.1 dB).
- [LIMIT-2 : F2] Modifies the displayed template standard line level Line level 2 in dB units (step: 0.1 dB).
- [LIMIT-3 : F3] Modifies the displayed template standard line level Line level 3 in dB units (step: 0.1 dB).
- [LIMIT-4 : F4] Modifies the displayed template standard line level Line level 4 in dB units (step: 0.1 dB).
- [LIMIT-5 : F5] Modifies the displayed template standard line level Line level 5 in dB units (step: 0.1 dB).
- [RETURN : F6] Returns to the high level SETUP TEMP function keys menu.

(1) PDC

User-defined pattern	(LIMIT-1) (LIMIT-2) (LIMIT-3) (LIMIT-4) (LIMIT-5)	- 70 dB - 60 dB 4 dB - 60 dB - 14 dB	
RCR-defined pattern (fixed)	(LIMIT-1) (LIMIT-2) (LIMIT-3) (LIMIT-4) (LIMIT-5)	- 70 dB - 60 dB 4 dB - 60 dB - 14 dB	
MS-COM symbol position (fixed)	1 2 3 4 5 6	- 2 symbol - 0.5 symbol 2 symbol 137 symbol 139.5 symbol 141 symbol	
MS-CONT symbol position (fixed)	1 2 3 4 5 6	- 2 symbol - 0.5 symbol 2 symbol 131 symbol 133.5 symbol 135 symbol	

(2) PHS

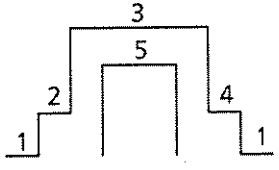
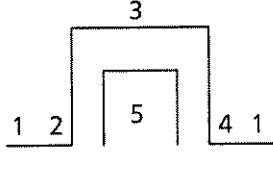
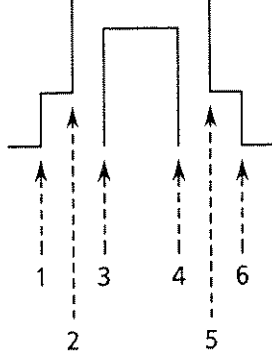
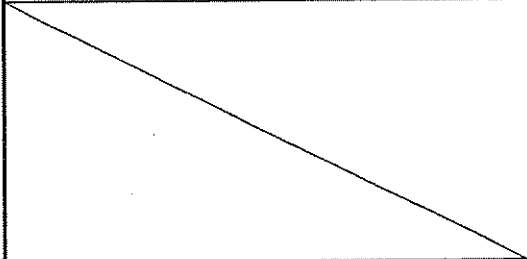
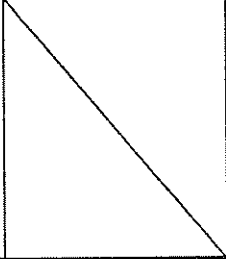
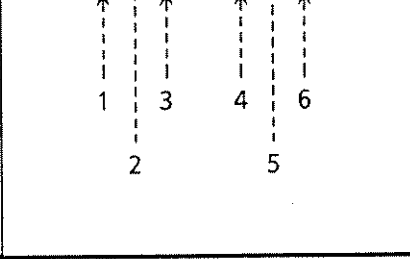
User-defined pattern (LIMIT-1) (LIMIT-2) (LIMIT-3) (LIMIT-4) (LIMIT-5)	- 56 dB - 50 dB 4 dB - 50 dB - 14 dB	
RCR-defined pattern (fixed)	(LIMIT-1) - 56 dB (LIMIT-2) - 56 dB (LIMIT-3) 4 dB (LIMIT-4) - 56 dB (LIMIT-5) - 14 dB	
Symbol position (fixed)	1 - 2 symbol 2 - 0.5 symbol 3 2 symbol 4 112 symbol 5 114.5 symbol 6 116 symbol	
		

(3) NADC

User-defined pattern	(LIMIT-1)	-60 dB	
	(LIMIT-2)	-50 dB	
	(LIMIT-3)	3 dB	
	(LIMIT-4)	-50 dB	
	(LIMIT-5)	-20 dB	
EIA/TIA-defined pattern (fixed)	(LIMIT-1)	-60 dB	
	(LIMIT-2)	-60 dB	
	(LIMIT-3)	3 dB	
	(LIMIT-4)	-60 dB	
	(LIMIT-5)	-20 dB	
MOBILE symbol position (fixed)	1	1 symbol	
	2	3 symbol	
	3	6 symbol	
	4	162 symbol	
	5	165 symbol	
	6	167 symbol	
SHORTENED symbol position (fixed)	1	1 symbol	
	2	3 symbol	
	3	6 symbol	
	4	140 symbol	
	5	143 symbol	
	6	145 symbol	

• [COPY TEMPLATE FROM : F4]

Displays the following COPY FROM function keys menu for copying a template from internal memory. Initial value: STANDARD

- [No.1 : F1] Copies the user-defined template saved in internal memory 1.
- [No.2 : F2] Copies the user-defined template saved in internal memory 2.
- [No.3 : F3] Copies the user-defined template saved in internal memory 3.
- [STANDARD : F5] Copies the template conforming to RCR standard.
- [RETURN : F6] Returns to the high level SETUP TEMP function keys menu.

• [BACK SCREEN : F6]

Returns to the high level RF POWER screen.

(5) Transmission timing measurement system

When performing transmission timing measurement, connect as follows.

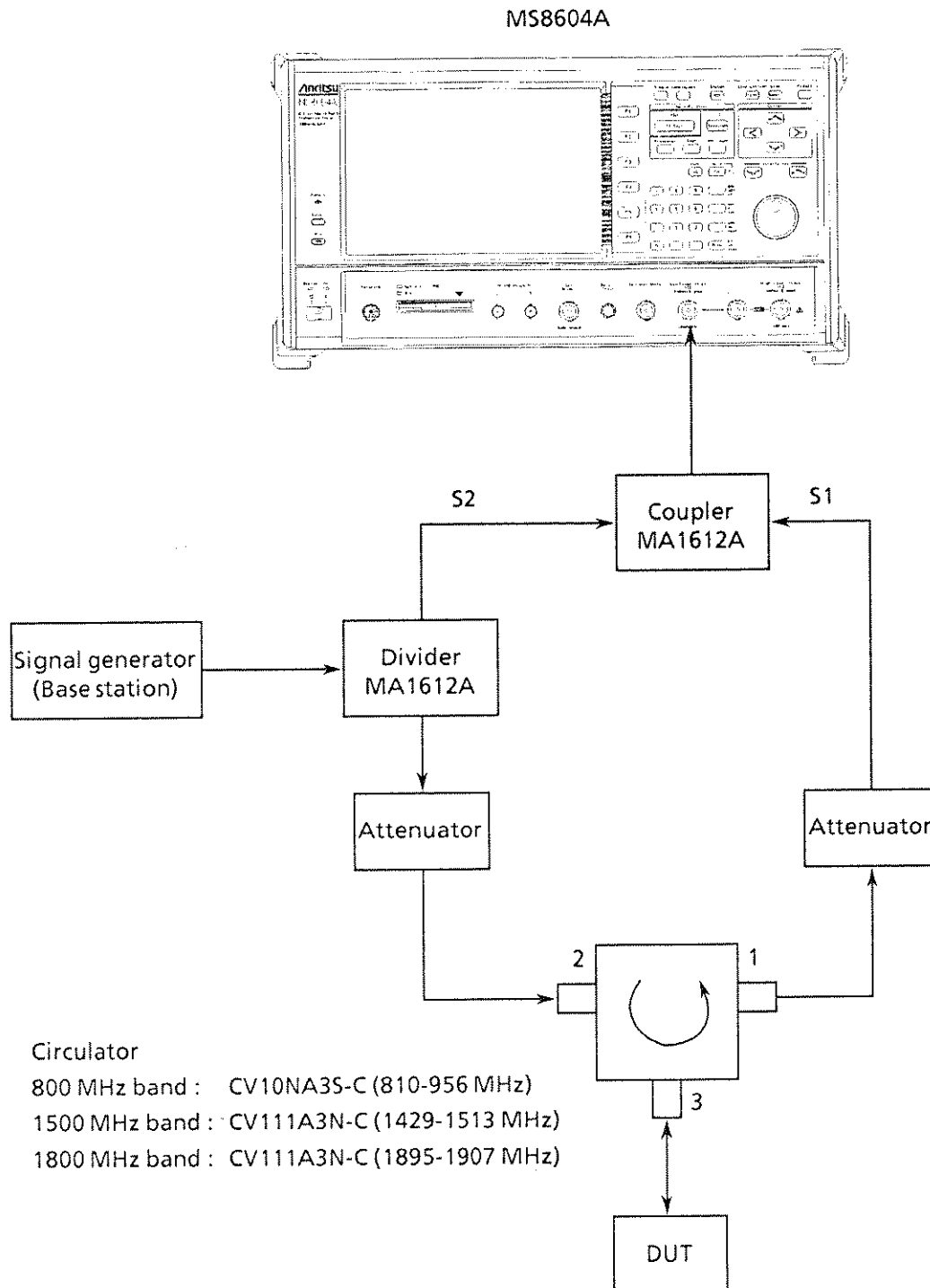

- Set the attenuation of the attenuator so that the signal S1 nearly equals (difference within 10 dB) the signal S2 from the signal generator.
- The difference from the standard timing for the measurement result is displayed in symbol units.

4.3.6 Occupied frequency bandwidth measurement (OCCUPIED BANDWIDTH)

Occupied frequency bandwidth measurement is entered by pressing the [OCCUPIED BANDWIDTH: F3] key after setting the parameters at the SETUP PARAMETER screen (paragraph 4.3.3).

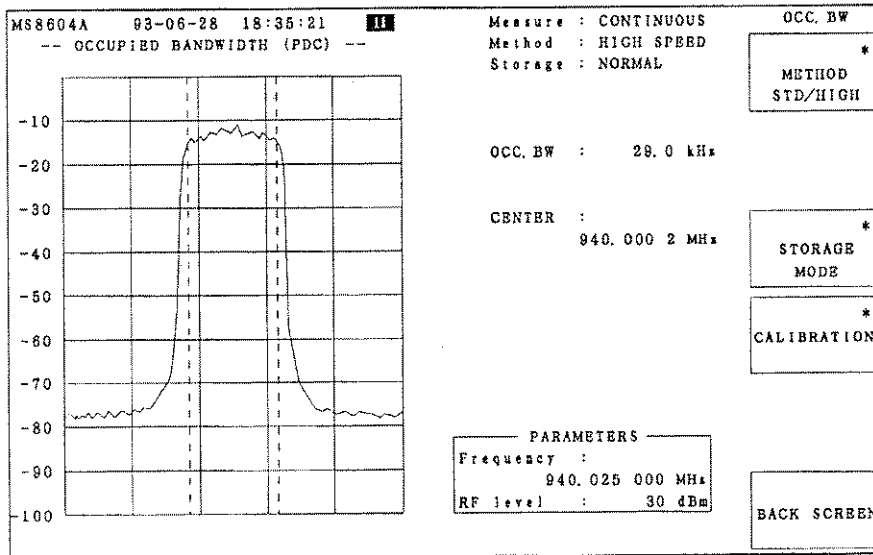

(1) Occupied bandwidth measured values

The spectrum measurement waveform is displayed in a window and the occupied frequency bandwidth is displayed by two dotted lines. The vertical axis scale is fixed at 0 to -100 dB. The occupied frequency bandwidth value OCC.BW is displayed in kHz units (step: 0.1 kHz).

(2) Central frequency measurement value

The central frequency of the upper limit frequency and lower limit frequency of the occupied frequency bandwidth is displayed.

$$\text{Center} = \frac{\text{Upper limit freq.} + \text{lower limit freq.}}{2}$$

① Waveform display SPAN width

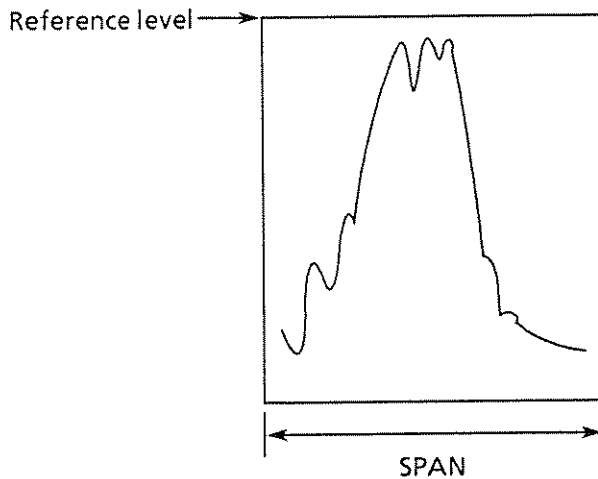

PDC :	STANDARD	100 kHz
	HIGH SPEED	≈ 100 kHz
PHS :	STANDARD	800 kHz
	HIGH SPEED	≈ 800 kHz
NADC :	SPECTRUM	100 kHz
	HIGH SPEED	≈ 100 kHz

② The reference level is automatically set to a value suitable for the level of the input signal.

(3) PARAMETERS

Displays the Frequency and RF level set at the SETUP PARAMETERS screen.

(4) Function keys

- [METHOD STD/HIGH : F1] (PDC/PHS), [METHOD SPECT/HIGH : F1] (NADC)

Displays the following METHOD function keys menu for selecting the occupied bandwidth measurement method (99 % method).

Initial value : HIGH SPEED

[STANDARD : F1] (PDC/PHS)	Measures the occupied frequency bandwidth by RCR standard by the spectrum analyzer. This function key can be selected only when INPUT Terminal of the SETUP PARAMETER screen is RF.
[SPECTRUM : F1] (NADC)	Measures the occupied frequency bandwidth by the spectrum analyzer. This function key can be selected only when INPUT Terminal of the SETUP PARAMETER screen is RF.
[HIGH SPEED : F2]	Measures the occupied frequency bandwidth at high speed by FFT (high-speed Fourier transformation).
[RETURN : F6]	Returns to the high level OCC.BW function keys menu.

- [STORAGE MODE : F3]

Displays the following STORAGE MODE function keys menu for selecting the display mode.
Initial value : NORMAL

[NORMAL : F1]

Normal mode.

[AVERAGE : F2]

Performs averaging processing.

At the end of the set number of averagings, measurement stops.

Note :The measurement mode is automatically set to SINGLE.

[ENTRY AVERAGE No. : F3]

Sets the number of averagings (2 to 99).

The number of averaging can be set in the Average OFF state also.

Initial value : 4

[RETURN : F6]

Returns to the high level OCC.BW function keys menu.

- [CALIBRATION : F4]

See paragraph 4.3.5 (5).

- [BACK SCREEN : F6]

Returns to the high level SETUP PARAMETER screen.

4.3.7 Adjacent channel leakage power measurement (ADJACENT CHANNEL POWER)

Adjacent channel leakage power measurement is entered by pressing the [ADJACENT CHANNEL POWER: F4] key after setting the parameters at the SETUP PARAMETER screen (paragraph 4.3.3).

METHOD : STANDARD (ALL) screen (PDC)

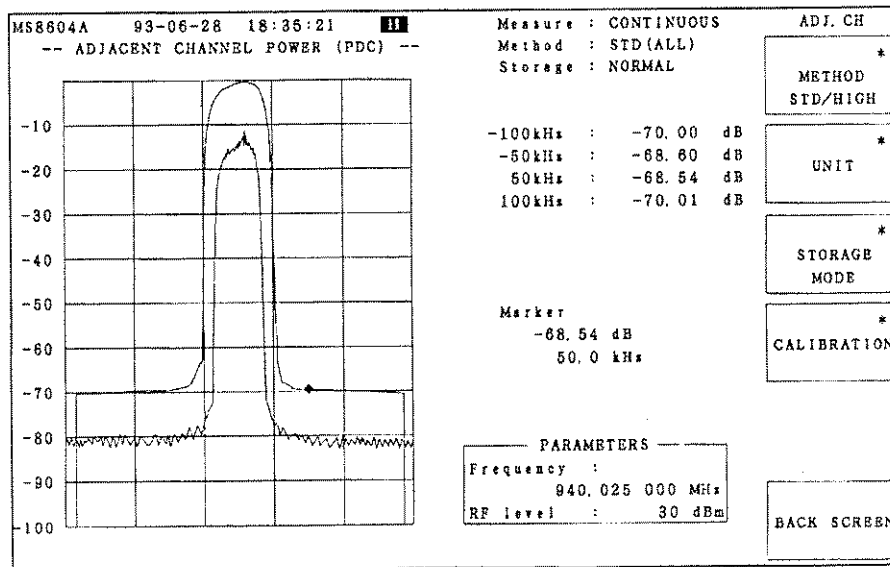

METHOD : HIGH SPEED screen (PDC)

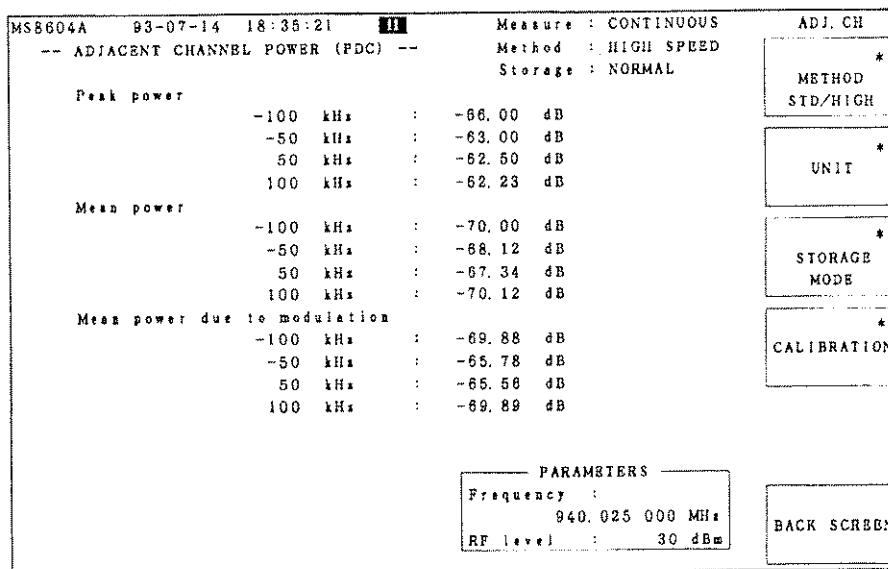

(1) Adjacent channel leakage power measured values

If the measurement method is STANDARD (PDC/PHS) or SPECTRUM (NADC), the spectrum measurement waveform is displayed in a window and the adjacent channel leakage power measured at ± 50 kHz, ± 100 kHz (PDC), ± 600 kHz, ± 900 kHz (PHS), ± 30 kHz, ± 60 kHz, and ± 90 kHz (NADC) is displayed at the right side of the window. The vertical axis scale is fixed at 0 to -100 dB.

If the measurement method is HIGH SPEED, the spectrum measurement waveform is not displayed and the peak power Peak power (PDC, PHS), Peak power from switching transients (NADC) mean power Mean power (PDC, PHS), and mean power of burst Mean power due to modulation at ± 50 kHz, ± 100 kHz (PDC), ± 600 kHz, ± 900 kHz (PHS), ± 30 kHz, ± 60 kHz, and ± 90 kHz (NADC) are displayed.

The adjacent channel leakage power measurement (HIGH SPEED) measurement method is shown below.

- ① The MS8604A is tuned to receive the adjacent channel frequency. The receive filter has a root-Nyquist filter characteristic.
- ② The adjacent channel leakage power after passing through the receive filter is shown below.

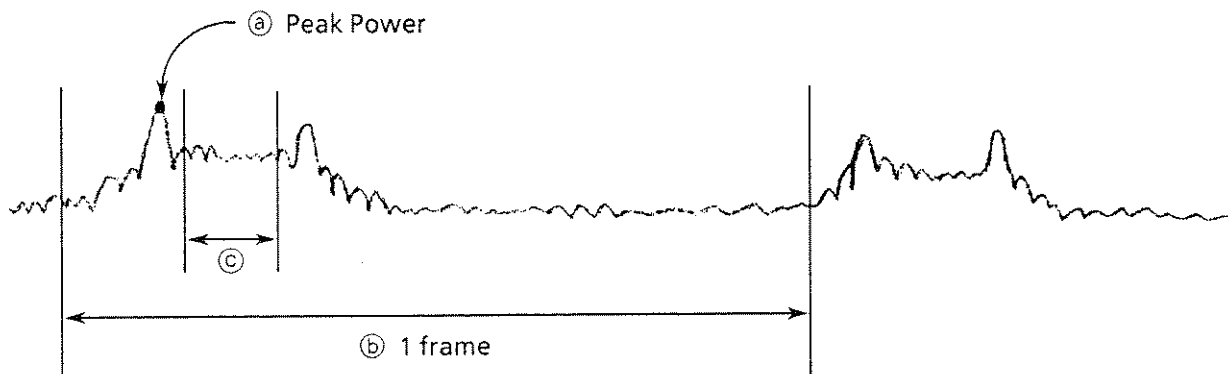

- (i) Peak Power (PDC, PHS), Peak Power from switching transient (NADC)
Displays the peak leakage power in one frame. (ⓐ in the figure above.)
- (ii) Mean Power (PDC, PHS)
Displays the mean power of one frame. (Mean power of zone ⓐ in the figure above.)
- (iii) Mean Power due to modulation
Displays the mean leakage power accompanying a burst ON zone. (Mean power of zone ⓒ in the figure above.)

If dB is selected as a unit in high-speed mode, reference levels are as follows:

- For PDC or PHS
If Peak Power, Mean Power, or Mean Power due to Modulation is displayed, the mean power in the burst that has passed the receiving filter is the reference level.
- For NADC
If Peak Power is displayed, the peak power in the burst that has passed the receive filter is the reference level. If Mean Power due to Modulation is displayed, the mean power in the burst that has passed the receive filter is the reference level.

The measurement result of "Mean Power due to Modulation" of all items displayed in high-speed mode is almost the same as that in standard (spectrum analyzer) mode. However, these measurement results may be different under a specific condition such as when a measured signal (burst wave) rapidly rises or falls.

In this case, measure the items in consideration of their inter relationship.

A peak measurement result in high-speed mode can be used to measure the leakage power of the transient part at the rising or falling edge of the waveform.

(2) PARAMETERS

Displays the Frequency and RF level set at the SET PARAMETER screen.

(3) Function keys

- [METHOD STD/HIGH : F1] (PDC, PHS), [METHOD SPEC/HIGH : F1] (NADC)

Displays the following METHOD function keys menu for selecting the adjacent channel leakage power measurement method. Initial value : HIGH SPEED

[STANDARD (ALL) MKR OFF/ON : F1]
(PDC, PHS)
[SPECTRUM (ALL) : F1] (NADC)

Sets the spectrum analyzer center frequency to the carrier frequency and makes all measurements in one sweep. This function can be selected only when INPUT Terminal of the SETUP PARAMETER screen is RF.

(The spectrum analyzer center frequency is set to the carrier frequency, SPAN is set to a value that includes all the adjacent channels to be measured, and the measured result of one sweep is displayed.)

When MKR ON/OFF is set to ON at PDC or PHS, the result integrated with specified bandwidth (PDC: 21 kHz, PHS: 192 kHz) at the MARKER and data points is graphically displayed in ratio (dB) from the carrier. The leakage power at any point can be read by MARKER.

[STANDARD (SEPARATE) : F2] (PDC, PHS)
[SPECTRUM (SEPARATE) : F2] (NADC)

Sets the spectrum analyzer center frequency to the frequency of the adjacent channel and the next adjacent channel and measures one adjacent channel at one sweep.

(Sets the spectrum analyzer SPAN to a value a little wider than the channel rated bandwidth, measures the respective levels while setting the center frequency to each measuring object adjacent channel and carrier frequency and displays the result.)

[HIGH SPEED : F3]

Measures the adjacent channel leakage power at high speed by digital signal processing.

[RETURN : F6]

Returns to the high level ADJ.CH function keys menu.

The measurement time when METHOD is STANDARD/SPECTRUM depends on the SETUP PARAMETER screen Channel per carrier FULL RATE/HALF RATE and spectrum mode SYSTEM parameter DATA-POINTS NORMAL (501 points)/(DOUBLE (1002 points) settings.

- [UNIT : F2]

Displays the following UNIT function keys menu for selecting the measured value power units of the adjacent channel leakage power and the relative display. Initial value : dBm

- | | |
|-----------------|--|
| [dBm : F1] | Sets the power units to dBm. |
| [mW : F2] | Sets the power units to mW. |
| [μ W : F3] | Sets the power units to μ W. |
| [nW : F4] | Sets the power units to nW. |
| [dB : F5] | Displays the power relative to the value of the carrier signal level of burst. |
| [RETURN : F6] | Returns to the high level ADJ.CH function keys menu. |

- [STORAGE MODE : F3]

Displays the following STORAGE MODE function keys menu for selecting the display mode. Initial value : NORMAL

- | | |
|--------------------------|---|
| [NORMAL : F1] | Normal mode |
| [AVERAGE : F2] | Performs averaging processing.
At the end of the set number of averagings, measurement stops.
<i>Note:</i> The measurement mode is automatically set to SINGLE. |
| [ENTRY AVERAGE No. : F3] | Sets the number of averagings (2 to 99). The number of averagings can be set in the Average OFF state also.
Initial value: 4 |
| [RETURN : F6] | Returns to the high level ADJ.CH function keys menu. |

- [CALIBRATION : F4]

See paragraph 4.3.4 (5).

- [BACK SCREEN : F6]

Returns to the high level SETUP PARAMETER screen.

4.3.8 Spurious emissions measurement (SPURIOUS EMISSIONS)

Measurement of the specified spurious emissions level (including harmonics) is entered by pressing the [SPURIOUS EMISSIONS: F5] key after setting the parameters at the SETUP PARAMETER screen (paragraph 4.3.3). The measurement mode is automatically set to SINGLE.

If the INPUT Terminal of the SETUP PARAMETER screen is IQ, spurious emissions cannot be measured.

MS8604A 93-07-14 18:35:21		SPURIOUS
-- SPURIOUS EMISSIONS (PDC) --		SPURIOUS * MODE
Spurious: SPOT		UNIT *
f 1 = 1 880.050 000 MHz	: -60.00 dB	RF * ATTENUATION
f 2 = 2 820.075 000 MHz	: -72.00 dB	CALIBRATION *
f 3 = 3 760.100 000 MHz	: -73.00 dB	FREQUENCY * TABLE
f 4 = 4 700.125 000 MHz	: -72.54 dB	BACK SCREEN
f 5 = - - - - - MHz	:	
f 6 = - - - - - MHz	:	
f 7 = - - - - - MHz	:	
f 8 = - - - - - MHz	:	
f 9 = - - - - - MHz	:	
f10 = - - - - - MHz	:	
f11 = - - - - - MHz	:	
f12 = - - - - - MHz	:	
f13 = - - - - - MHz	:	
f14 = - - - - - MHz	:	
f15 = - - - - - MHz	:	
PARAMETERS		
Frequency :	940.025 000 MHz	
RF level :	30 dBm	

(1) Spurious emission measured values

Displays the signal level of up to 15 set frequencies by frequency table.

(2) PARAMETERS

Displays the Frequency and RF level set at the SETUP PARAMETER screen.

(3) Function keys

- [SPURIOUS MODE : F1]

Displays the following SPURIOUS MODE function keys menu for selecting the spurious emissions measurement method. Initial value : SPOT

[SPOT : F1]	Measures and displays the level at the frequencies set in the table of spurious emissions measurement frequencies.
[SEARCH : F2]	Sweeps ± 500 kHz to either side of the frequencies set in the table of spurious emissions measurement frequencies and measures and displays the maximum level.
[RETURN : F6]	Returns to the high level SPURIOUS function keys menu.

- [UNIT : F2]

Displays the following UNIT function keys menu for selecting the level measured value units and relative display. Initial value : dBm

[dBm : F1]	Sets the level units to dBm.
[mW : F2]	Sets the level units to mW.
[μ W : F3]	Sets the level units to μ W.
[nW : F4]	Sets the level units to nW.
[dB : F5]	Displays the level relative to the value of the carrier signal level of a burst.
[RETURN : F6]	Returns to the high level SPURIOUS function keys menu.

- [RF ATTENUATION : F3]

Displays the following ATTENUATION function keys menu to facilitate detection of spurious emissions by changing the RF signal input attenuator attenuation setting mode. Initial value : NORMAL

[NORMAL : F1]	Sets the attenuation by normal automatic setting.
[NOISE : F2]	Makes the attenuation small so that spurious emissions can be easily detected by minimizing the noise component.
[RETURN : F6]	Returns to the high level SPURIOUS function keys menu.

- [CALIBRATION : F4]

See paragraph 4.3.4 (5).

- [FREQUENCY TABLE : F5]

Displays the following FREQUENCY TABLE function keys menu for selecting the table of spurious emissions measurement frequencies.

[SELECT FREQUENCY TABLE : F1]

Displays the following SELECT TABLE function keys menus for calling user-set frequency tables No.1 to No.3 saved in the internal memories.

Initial value : No.1

[[No.1 : F1]	Calls frequency table No.1 saved in internal memory 1.
	[No.2 : F2]	Calls frequency table No.2 saved in internal memory 2.
	[No.3 : F3]	Calls frequency table No.3 saved at internal memory 3.
	[RETURN : F6]	Returns to the high level SPURIOUS function keys menu.

[SETUP FREQUENCY TABLE : F5]

Displays the spurious emissions measurement frequency input screen SETUP FREQUENCY TABLE for setting the measurement frequency. See item (4) below.

Initial value :

(Unit : MHz)

	PDC	PHS	NADC
f1	1 880.050 000	3 790.300 000	1 650.060 000
f2	2 820.075 000	5 685.450 000	2 475.090 000
f3	3 760.100 000	7 580.600 000	3 300.120 000
f4	4 700.125 000		4 125.150 000
f5			4 950.180 000
f6			5 775.210 000
f7			6 600.240 000
f8			7 425.270 000
f9			8 250.300 000

[RETURN : F6]

Returns to the high level SPURIOUS function keys menu.

- [BACK SCREEN : F6]

Returns to the high level SETUP PARAMETER screen.

(4) Spurious emissions measurement frequency table creation

The spurious emissions measurement frequency input screen SETUP FREQUENCY TABLE for saving, modifying, copying, and deleting the frequency tables is displayed by pressing the [FREQUENCY TABLE: F5] or [SETUP FREQUENCY TABLE: F5] key on the SPURIOUS EMISSIONS screen.

MS8604A 93-07-14 18:35:21		SETUP TABLE
-- SETUP FREQUENCY TABLE (PDC) --		SAVE * FREQUENCY TABLE
Frequency table : No. 1		MODIFY *
f 1 =	1 880.050 000 MHz	
f 2 =	2 820.075 000 MHz	
f 3 =	3 760.100 000 MHz	
f 4 =	4 700.125 000 MHz	
f 5 =	- - - - - MHz	
f 6 =	- - - - - MHz	
f 7 =	- - - - - MHz	
f 8 =	- - - - - MHz	
f 9 =	- - - - - MHz	
f10 =	- - - - - MHz	
f11 =	- - - - - MHz	
f12 =	- - - - - MHz	
f13 =	- - - - - MHz	
f14 =	- - - - - MHz	
f15 =	- - - - - MHz	
		COPY * TABLE FROM
		CLEAR *
		BACK SCREEN
FREQUENCY = 1 880.050 000 MHz		

- 1 Up to 15 frequencies can be registered in the spurious emissions frequency table.
- 2 User-set frequency tables (No.1 to No.3) can be saved to internal memories No.1 to No.3.
- 3 When the displayed frequency table is modified, Frequency table: name becomes NOT SELECTED to show that frequency tables are not saved in the internal memories.
- 4 The following SETUP TABLE function keys menu is displayed for saving, modifying, copying, and deleting frequency tables.

- [SAVE FREQUENCY TABLE : F1]

Displays the following SAVE TABLE function keys menu for saving the displayed frequency table. If a frequency table is not displayed, this key is ineffective. Initial value : No.1

[No.1 : F1]	Saves the displayed frequency table to internal memory 1.
[No.2 : F2]	Saves the displayed frequency table to internal memory 2.
[No.3 : F3]	Saves the displayed frequency table to internal memory 3.
[RETURN : F6]	Returns to the high level SPURIOUS function keys menu.

- [MODIFY : F2]

The frequency data at the cursor position can be input from the ten-key pad.

When the cursor is moved to a blank line - - - and is input with the Step/Select key (1 MHz step) or rotary knob (1 kHz step), the frequency is incremented or decremented in 1 MHz or 1 kHz steps, with the Frequency of the SETUP PARAMETER screen as the initial value.

The following MODIFY function keys menu is displayed for modifying the displayed frequency table.

[DELETE : F1]	Deletes the cursor position frequency, moves all the frequencies following the cursor up one line and makes the cursor frequency data entry state.
[INSERT : F2]	Moves all the frequencies following the cursor down one lines, creates a blank line - - - at the cursor position and makes the frequency data entry state.
[HARMONICS : F3]	Automatically sets the harmonics from twice to five times (PDC/PHS) or 10 times (NADC) the SETUP PARAMETER screen frequency at f1 to f4 (PDC/PHS) or f1 to f10 (NADC). The previously set frequencies are deleted. Harmonics over 8.5 GHz are not displayed.
[RETURN : F6]	Returns to the high level SETUP TABLE function keys menu.

- [COPY TABLE FROM : F4]

Displays the following COPY FROM function keys menu for copying the frequency tables from the internal memories.

[No.1 : F1]	Copies the user-defined frequency table saved in the internal memory 1.
[No.2 : F2]	Copies the user-set frequency table saved in the internal memory 2.
[No.3 : F3]	Copies the user-set frequency table saved in the internal memory 3.
[RETURN : F6]	Returns to the high level SETUP TABLE function keys menu.

- [CLEAR : F5]
Displays the following CLEAR function keys menu for deleting all the frequencies in the displayed frequency table. The saved frequency tables are not deleted.
 - [APPLY : F1] Executes deletion.
 - [RETURN : F6] Returns to the high level SETUP TABLE function table menu.
- [BACK SCREEN : F6]
Returns to the high SPURIOUS EMISSIONS screen.

4.3.9 Power meter (POWER METER)

Measurement is entered by pressing the [etc. : F6] key to display page 2, then pressing the [POWER METER : F5] key on the MODE screen (paragraph 4.3.2).

- (I) The measurement range when the power sensor is connected directly to an external device is - 20 dBm to + 20 dBm. (At SENSOR CONNECT TO DUT)
- (II) The measurement range when measuring the MS8604A High Power Input input signal (when measuring the output power of a transmitter), is 0 dBm to + 40 dBm. (At SENSOR CONNECT TO TESTER)

If accurate measurement of the transmit power in TX Test mode is required (RF power, adjacent channel, spurious emissions), first calibrate the power meter at this screen. At the same time, also input the measured signal frequency at Frequency.

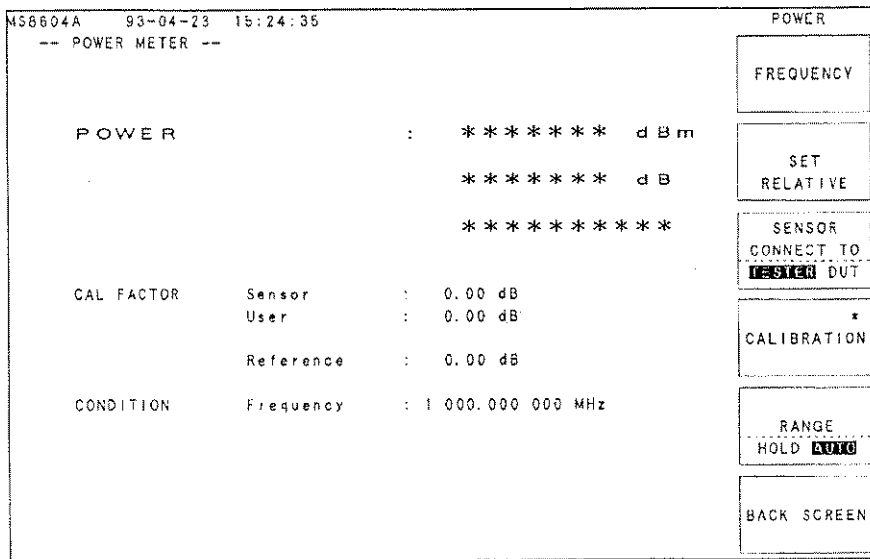

(1) Displayed values

The following values are displayed:

(a) POWER

Displays the power measured value in dBm and W units. Also displays the measured value relative to the power when the [SET RELATIVE : F2] key was pressed in dB units.

(b) CAL FACTOR Sensor/User/Reference

The sensor calibration factor at the currently set measurement frequency (Sensor), user-set calibration factor (User), and the sensor calibration factor at 50 MHz (Reference) are displayed, respectively.

(c) CONDITION Frequency

Displays the currently set measurement frequency.

(2) Function keys

• [FREQUENCY : F1]

Input the frequency of the measured signal. Initial value : 1 000.000 000 MHz

• [SET RELATIVE : F2]

Displays the value relative to the power when the key was pressed as reference 0 dB. If the display is switched from the POWER METER screen or if the power is turned off, this key is disabled.

• [SENSOR CONNECT TO TESTER/DUT : F3]

If connecting the sensor to the To Power Sensor connector and measuring the power input to the MS8604A as shown in the setup drawing in paragraph 4.3.1 (1), select TESTER.

If measuring power by connecting the sensor directly to an external device, select DUT (Device Under Test).

The selected item is reverse displayed.

Initial value : TESTER

• [CALIBRATION : F4]

Displays the following CALIBRATION function keys menu for setting the calibration factor Cal factor and calibrating the power meter.

[CAL FACTOR : F1]

Displays the following CAL FACTOR function keys menu for setting the calibration factor Cal factor.

Initial value : SENSOR

[SENSOR : F1]

Displays the SENSOR CAL FACTOR input screen SETUP SENSOR CAL FACTOR is displayed to input SENSOR CAL FACTOR and REFERENCE CAL FACTOR.

See paragraph (4).

[USER : F2]

Inputs the user-set calibration factor.

Range : - 30.00 to 30.00 dB (step : 0.01 dB)

Initial value : 0 dB

User cal.factor example:

20 dB amplifier calibration factor : - 20 dB

10 dB attenuator calibration factor : + 10 dB

[RETURN : F6]

Returns to the high level CALIBRATION function keys menu.

[CAL OSCILLATOR ON/OFF : F3]

Turns the calibration oscillator (Cal Output 0 dBm 50 MHz connector) output level on and off. Initial value : OFF

[CAL ADJUST : F4]

After calibration factor setting, sensor zero calibration, and calibration oscillator On setting, sensor calibration at 50 MHz is performed by pressing this key after connecting the sensor to the Cal Output 0 dBm 50 MHz connector.

[ZERO SET : F5]

After calibration factor setting, sensor zero calibration is performed by pressing this key after disconnecting the sensor input.

[RETURN : F6]

Returns to the high level POWER METER function keys menu.

- [RANGE HOLD/AUTO : F5]

Alternately selects holding the current power measurement range (hard range) (HOLD) and automatic switching (AUTO). The selected item is reverse displayed.
Initial value : AUTO

- [BACK SCREEN : F6]

Returns to the high level MODE screen.

(3) SENSOR (REFERENCE) CAL FACTOR input

Displays the SENSOR CAL FACTOR input screen SETUP SENSOR CAL FACTOR to input SENSOR CAL FACTOR and REFERENCE CAL FACTOR by pressing the [CAL FACTOR : F1] and [SENSOR : F1] keys at the POWER METER screen.

MS8604A 93-07-14 18:35:21		SETUP TABLE
-- SETUP SENSOR CAL FACTOR --		
0.1 MHz =	0.30 dB	
0.3 MHz =	0.00 dB	
1.0 MHz =	0.00 dB	
3.0 MHz =	0.00 dB	
10.0 MHz =	0.00 dB	
30.0 MHz =	0.00 dB	
50.0 MHz =	0.00 dB	(Reference)
100.0 MHz =	0.00 dB	
300.0 MHz =	0.00 dB	
1000.0 MHz =	0.00 dB	
2000.0 MHz =	0.00 dB	
3000.0 MHz =	0.00 dB	
4000.0 MHz =	0.00 dB	
5000.0 MHz =	0.00 dB	
5500.0 MHz =	0.00 dB	

BACK SCREEN

0.1 MHz 0.00 dB

Input all SENSOR CAL FACTORS displayed at the power sensor MA4601A.

Set REFERENCE CAL FACTOR to SENSOR CAL FACTOR of 50 MHz.

Computes automatically SENSOR CAL FACTOR at the measured frequency (frequency set at FREQUENCY) and displays it at the CAL FACTOR SENSOR item of the POWER METER screen.

Range: - 1.00 to 1.00 dB (step : 0.01 dB)

Initial value : 0 dB

(4) Power measurement

Perform power measurement in TESTER or DUT mode as follows:

Step	Key operation	Description
1	TX Test	Sets the MS8604A to TX Test mode. The MODE screen appears.
	<i>Note:</i> When the system measurement setup parameter screens are displayed, press [BACK SCREEN] to leave the setup parameter screen.	
2	[etc] F6 [POWER METER] F5	The POWER METER screen appears.
3	[CALIBRATION] F4 [CAL FACTOR] F1 [SENSOR] F1 [BACK SCREEN] F6	The SENSOR CAL FACTOR input screen is displayed. Input CAL FACTOR displayed at the MA4601A sensor.
4	[USER] F2	Execute when USER CAL FACTOR is used. Input the connection cable loss, etc. correction value.
5		Turn off the sensor input by disconnecting the sensor from the To Power Sensor connector.
6	[RETURN] F6 [ZERO SET] F5	Zero-calibrates the sensor.
7		Connect the sensor to the Cal Output connector (0 dBm, 50 MHz).
8	[CAL ADJUST] F4	Calibrates the sensor.
9		Connect the sensor to To Power Sensor connector or the external DUT.
	[RETURN] F6 [RETURN] F6 [SENSOR CONNECT TO] F6	
		When the sensor is connected to To Power Sensor, select TESTER, and when connected directly to the DUT, select DUT. (Change High Power Input and Low Power Input at the System screen.)

Step	Key operation	Description
10	[FREQUENCY] [F1]	Inputs the frequency of the measured signal.
	--- Power measurement ---	
11		Set the measured output to ON and read the power measurement value on the screen.

4.4 Spectrum Analyzer Function SPECTRUM mode

This paragraph describes operation when using the spectrum analyzer function to conduct frequency domain and time domain tests.

4.4.1 Outline of setting

Setting starts from setting the measurement mode to the SPECTRUM mode by pressing the front panel Main Function [Spectrum] key.

The [Frequency], [Span], and [Amplitude] keys can be used in SPECTRUM mode.

The following items are set with the function keys displayed at the bottom of these four keys, as required.

[Spectrum]

Frequency domain : Display mode (NORMAL, maximum value MAX/minimum value MIN/average value AVG, dot [measurement point] cumulative display CUM/trace [measurement line] overwrite OVER, sweep stop VIEW)
Detect mode (Maximum value Pos. peak between sampling points, minimum value Neg. peak between sampling points, sampling points instantaneous value Sample)

Time domain : Delay time Delay time, time span, expanded mode EXPAND
Display mode (NORMAL, Max/Min/AVG, CUM/OVER, VIEW)
FM/external trigger signal waveform monitor

Sweep mode : Zone, tracking

Gate, trigger

Resolution bandwidth RBW, video bandwidth VBW, sweep time SWT, RF input attenuator ATTEN

Marker : Normal marker, delta marker, zone marker,
multi marker (Highest 10, Harmonics, Manual)
Marker movement (→Peak, Dip, CF, Ref.level, CF step, Span)

Automatic tuning Auto tune (frequency domain only)

Sound monitor : AM, FM

Parameters setup list display

System setting : Sweep time mode (Fast/Slow),
Number of data points (Normal 501/Double 1002),
Frequency domain and time domain RBW-VBW-SWT setting mode
(Common/Independent)

Calibration : All, level, frequency, preselector tuning

[Spectrum] [Frequency] - - - Frequency setting

Center frequency CF
Start frequency
Stop frequency
Start/span frequency

[Spectrum] [Span] - - - Frequency span/frequency band setting

Span frequency : Manual, full, zero

Frequency band : Auto, manual (0 : 0 to 2 GHz, 1 - : 1.7 to 7.5 GHz, 1 + : 6.5 to 8.5 GHz)

[Spectrum] [Amplitude] --- Level setting

Reference level

Log scale : 10 to 1 dB/div, dBm/dB μ V/dBmV/V/dB μ V (emf)

Lin scale : 10 to 1 %/div, V

Note : The screens and the setting items and function keys flow at each screen are summarized in Appendix A Screens and Function Keys Transition Diagram.

4.4.2 Frequency domain or time domain selection (TRACE FREQ/TIME)

There are two SPECTRUM mode screens: frequency domain screen and time domain screen. freq or time (expansion mode time-EXP) is displayed at the right top of the respective screen. (See paragraph 4.2.2.)

The initial screen is the frequency domain screen.

The following keys are operated to select the frequency domain or time domain screen.

Step	Key operation	Description
1	Spectrum	Displays page 1 of the SPECTRUM function keys menu.
2	TRACE FREQ/TIME F2	Displays the TRACE function keys menu.
3	TRACE-FREQ F1 or TRACE-TIME F2	Selects frequency domain. Selects time domain.

Step	Key operation	Description
1	Spectrum Span	Displays the SPAN function keys menu.
2	ZERO SPAN F2 or 0 Enter	Selects time domain. (Frequency span = 0)

Spectrum

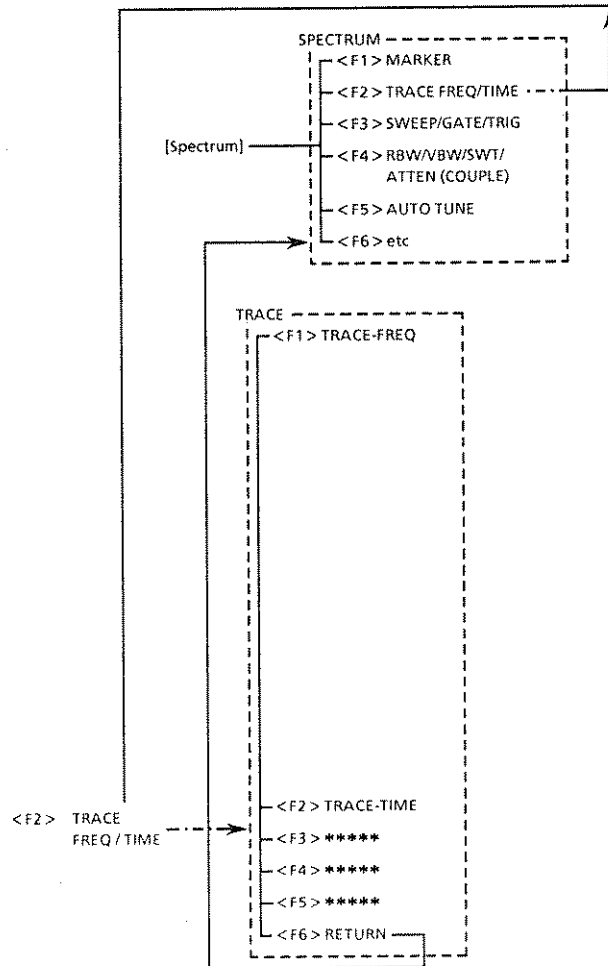

4.4.3 Frequency setting

The frequency is set after selecting the SPECTRUM mode by pressing the front panel Main Function [Spectrum] key, then pressing the [Frequency] key or [Span] key.

The frequency is set by one of the following combinations:

- CENTER-SPAN
- START-STOP
- START-SPAN

The set value is displayed by

CENTER : *** SPAN : ***
 START : *** STOP : ***
 START : *** SPAN : ***

at the bottom of the scale.

(1) Range

Start/center/stop frequency :	100 Hz to 8.5 GHz (1 Hz step)
Span :	FULL ZERO 100 Hz to 8.50 GHz (3 digits: 100 to 999) (1-2-5 sequence by step key)
Center frequency step size by Step/Select [↑][↓] key :	100 Hz to 8.5 GHz (1 Hz step)
Frequency band :	AUTO MANUAL 0 (0 to 2 GHz) MANUAL 1- (1.7 to 7.5 GHz) MANUAL 1+ (6.5 to 8.5 GHz)

(2) Initial values

Start frequency :	0 Hz
Center frequency :	4.25 GHz
Stop frequency :	8.50 GHz
Span frequency :	8.50 GHz
Center frequency step size :	1 GHz
Frequency band :	AUTO (0 to 8.5 GHz)

(3) Data input

Data is input as follows:

- Frequency setting and span setting by ten-key pad [.] [0] to [9] and unit keys [GHz] [MHz] [kHz] [Hz]
- Frequency setting and span setting by rotary knob
- Center frequency setting and span selection (1-2-5 sequence) by Step/Select [↑][↓] key

Other data is input using function keys menu. (See Appendix A.)

Frequency

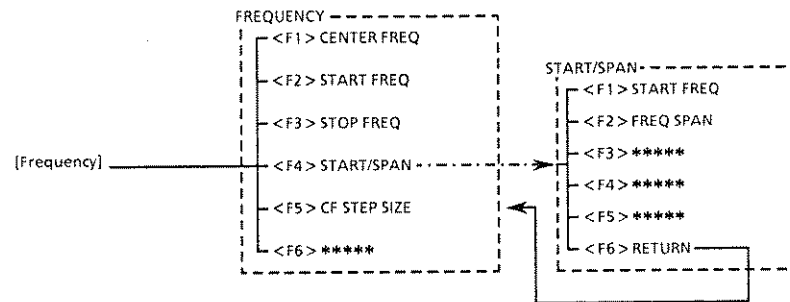

Note : If the frequency band is fixed by the SPAN function keys menu [MANUAL 0 : F4], [MANUAL 1- : F5], or [MANUAL 1+ : F6] key, when set to full span by the [FULL SPAN : F1] key, the span becomes the full span in that frequency band.

Example: Set center frequency 3.456789 GHz and span 50 MHz in the CENTER-SPAN mode and raise the center frequency by 100 kHz in 25 kHz steps.

Step	Key operation	Description
1	Spectrum	Selects SPECTRUM mode.
2	Span	Displays the SPAN function keys menu.
3	AUTO BAND F3	Sets the frequency band to AUTO. (If the frequency band is already AUTO, this operation is unnecessary.)
4	Frequency CENTER FREQ F1 3 . 4 5 6 7 8 9 GHz	Displays the FREQUENCY function keys menu. Sets the center frequency to 3.456789 GHz.
5	Span 5 0 MHz or Step/Select ^ v	Sets the span to 50 MHz. Press until the span reaches 50 MHz.
6	Frequency CF STEP SIZE F5 2 5 kHz	Sets the center frequency step size to 25 kHz.
7	Frequency	
8	Step/Select ^ ^ ^ ^	Raises the center frequency 100 kHz in 25 kHz steps.

4.4.4 Automatic tuning (AUTO TUNE)

If the SPECTRUM function keys menu is displayed by pressing the [Spectrum] key and then the [AUTO TUNE : F5] key is pressed, the maximum level signal in the 85 MHz to 8.5 GHz band is detected automatically. The frequency of that signal is set the center frequency and its level is set the reference level.

Span is set to the value before the [AUTO TUNE : F5] key was pressed. However, when the span is higher than 100 MHz, it is set to 100 MHz.

RF input attenuator setting becomes AUTO.

The [AUTO TUNE : F5] key is not effective in time domain mode.

The related function keys menu is shown below.

Spectrum

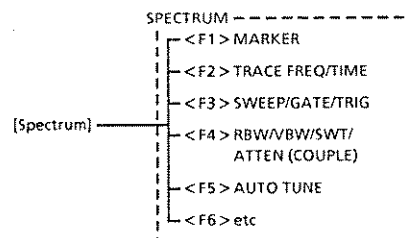

4.4.5 Level setting

The level is set after setting the MS8604A to SPECTRUM mode by pressing the front panel Main Function [Spectrum] key, then pressing the [Amplitude] key.

The setting items are:

- 1 Reference level
- 2 Reference level step size by Step/Select [↑][↓] key
- 3 Log scale
- 4 Lin scale
- 5 Log scale reference level units

(1) Ranges and initial values

Reference level

RF input : High

Scale	Unit	Reference level range	Note
Log	dBm	- 80 to + 50 dBm	Termination voltage
	dB μ V	+ 27 to + 157 dB μ V	Termination voltage
	dBmV	- 33 to + 97 dBmV	Termination voltage
	V	22 μ V to 70.7 V	Termination voltage
	dB μ V (emf)	+ 33 to + 163 dB μ V (emf)	Open voltage
Lin	V	223 μ V to 70.7 V	Termination voltage

RF input : Low

Scale	Unit	Reference level range	Note
Log	dBm	- 100 to + 30 dBm	Termination voltage
	dB μ V	+ 7 to + 137 dB μ V	Termination voltage
	dBmV	- 53 to + 77 dBmV	Termination voltage
	V	2.2 μ V to 7.07 V	Termination voltage
	dB μ V (emf)	+ 13 to + 143 dB μ V (emf)	Open voltage
Lin	V	22.3 μ V to 7.07 V	Termination voltage

Initial value + 10 dBm (RF input : High)
 - 10 dBm (RF input : Low)

Reference level step size by Step/Select [↑][↓] key

Log scale : 1 div, 2 div, 5 div, 10 div, MANUAL
 Lin scale : 1 div (fixed)
 Initial value 1 div

Log scale

10 dB/div, 5 dB/div, 2 dB/div, 1 dB/div

Initial value 10 dB/div

Note : Can also be set in time domain mode.

Lin scale

10 %/div, 5 %/div, 2 %/div, 1 %/div
Initial value 10 %/div

Log scale reference level unit

dBm, dB μ V, dBmV, V, dB μ V (emf)
Initial value dBm
(Lin scale unit is V only.)

(2) Data input

The reference level data is input by any of the following methods:

- Level setting by ten-key pad [.] [0] to [9] and unit key [dBm] [V] [mV] [μ V]
- Level setting by rotary knob
- Level setting by Step/Select [\uparrow] [\downarrow] key

Other data is input using the function keys menu. (See Appendix A.)

Amplitude

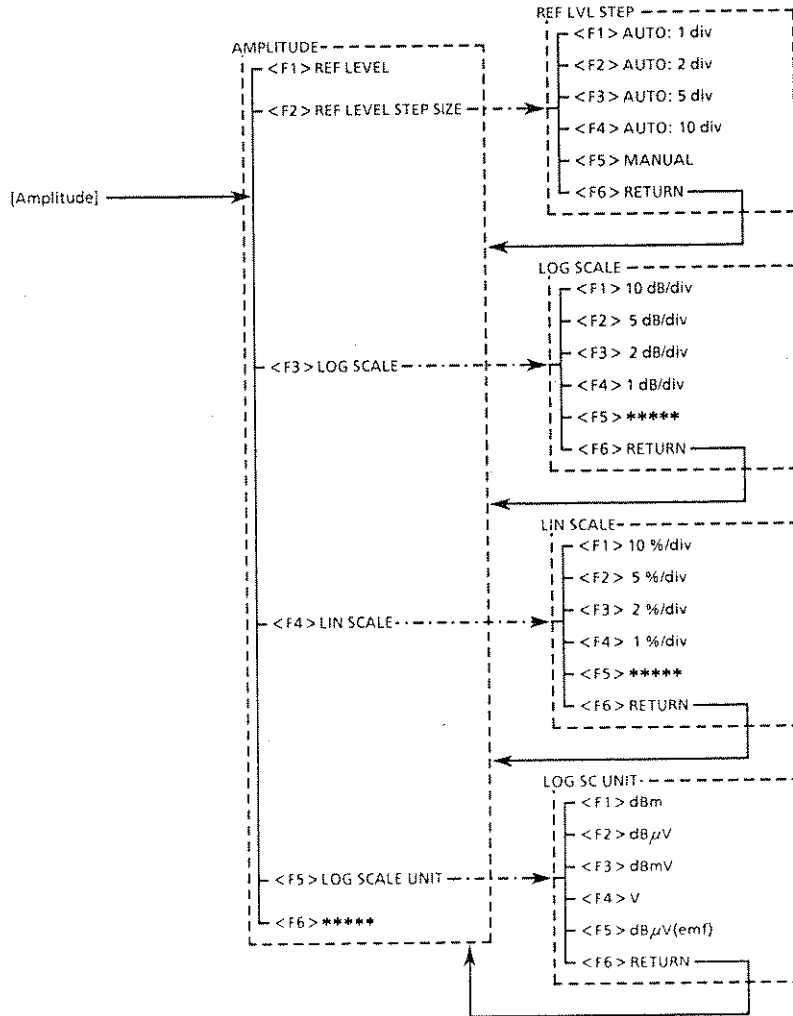

Notes : 1. Unit setting is performed by LOG SC UNIT function keys menu, but reference level input using the set unit is performed by panel key.

Unit setting key (LOG SC UNIT function keys menu)	Reference level input key (Panel key)
[dBm : F1]	[dBm]
[dB μ V : F2]	[dBm]
[dBmV : F3]	[dBm]
[dB μ V (emf) : F5]	[dBm]
[V : F4]	[V], [mV], [μ V]

2. When the Log scale reference level setting is under -60 dBm (RF input High), -80 dBm (RF input Low), it cannot be changed to Lin scale.

Example: Set Log scale to 2 dB/div, reference level to 50 dBmV, and reference level step size to 1 div and change the reference level from 50 to 40 dBmV.

Step	Key operation	Description
1	Spectrum Amplitude	Displays the AMPLITUDE function keys menu.
2	LOG SCALE F3 2dB/div F3	Displays the LOG SCALE function keys menu and sets the scale to Log scale. Sets 2 dB/div.
3	RETURN F6 LOG SCALE UNIT F5 dBmV F6 RETURN F6	Returns to the AMPLITUDE function keys menu. Displays the LOG SC UNIT function keys menu. Sets the reference level units to dBmV. Returns to the AMPLITUDE function keys menu.
4	REF LEVEL STEP SIZE F2 AUTO 1 div F1	Displays the REF LVL STEP function keys menu. Sets the reference level step size to 1 div.
5	RETURN F6	Returns to the AMPLITUDE function keys menu.
6	REF LEVEL F1 5 0 dBm	Sets the reference level to 50 dBmV. (Note 1 on preceding page.)
7	Step/Select ∇ ∇ ∇ ∇ ∇	Change the reference level from 50 to 40 dBmV.

4.4.6 Frequency domain display mode and detection mode setting

This paragraph describes frequency domain display mode and detection mode setting.

- Display mode

The display method can be selected from the following items:

NORMAL, maximum value MAX (MAX HOLD)/minimum value MIN (MIN HOLD)/average value AVG (AVERAGE), dot [measurement point] cumulative display CUM (CUMULATIVE)/trace [measurement line] overwrite OVER (OVERWRITE), sweep stop VIEW

- Notes :
1. If the average value was measured, measurement does not stop after the set number of averaging sweeps.
 2. During average value measurement, the current sweep number * is displayed by AVG = * at the top left of the screen.
 3. The number of averagings can be set at anytime, regardless of the AVERAGE ON/OFF setting.
 4. Average value measurement improves the S/N ratio as shown below.

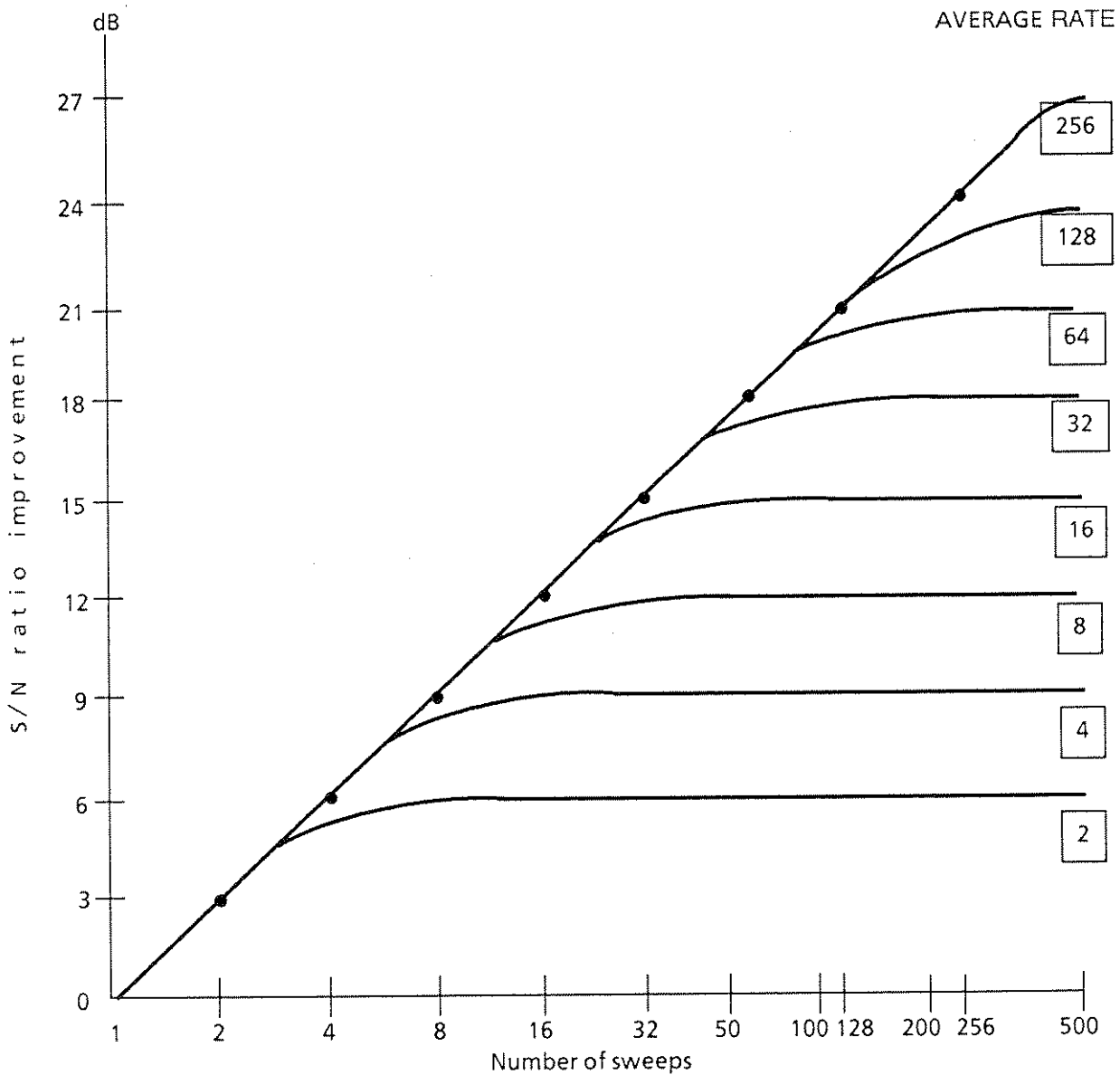

S/N ratio improvement by digital video averaging

- Detection mode

The detection mode can be selected from the following three modes:

Maximum value between sample points POS PEAK, minimum value between sample points NEG PEAK, instantaneous value of sample point SAMPLE

(1) Ranges and initial values

Display mode : NORMAL, MAX, MIN, AVG, CUM, OVER

Initial value : NORMAL

Average value setting (AVERAGE) : ON, OFF

Initial value : OFF

Number of averagings (AVERAGE NO.) : 2, 4, 8, 16, 32, 64, 128, 256

Initial value : 8

Detection mode : POS PEAK, NEG PEAK, SAMPLE

Initial value : POS PEAK

(2) Data input

The number of averagings data can be input in any of the following ways:

- Number of averagings setting by ten-key pad [0] to [9] and [Enter] key
- Number of averagings setting by rotary knob
- Number of averagings setting by Step/Select [↑][↓] key

Other data is input by function keys menu. (See Appendix A.)

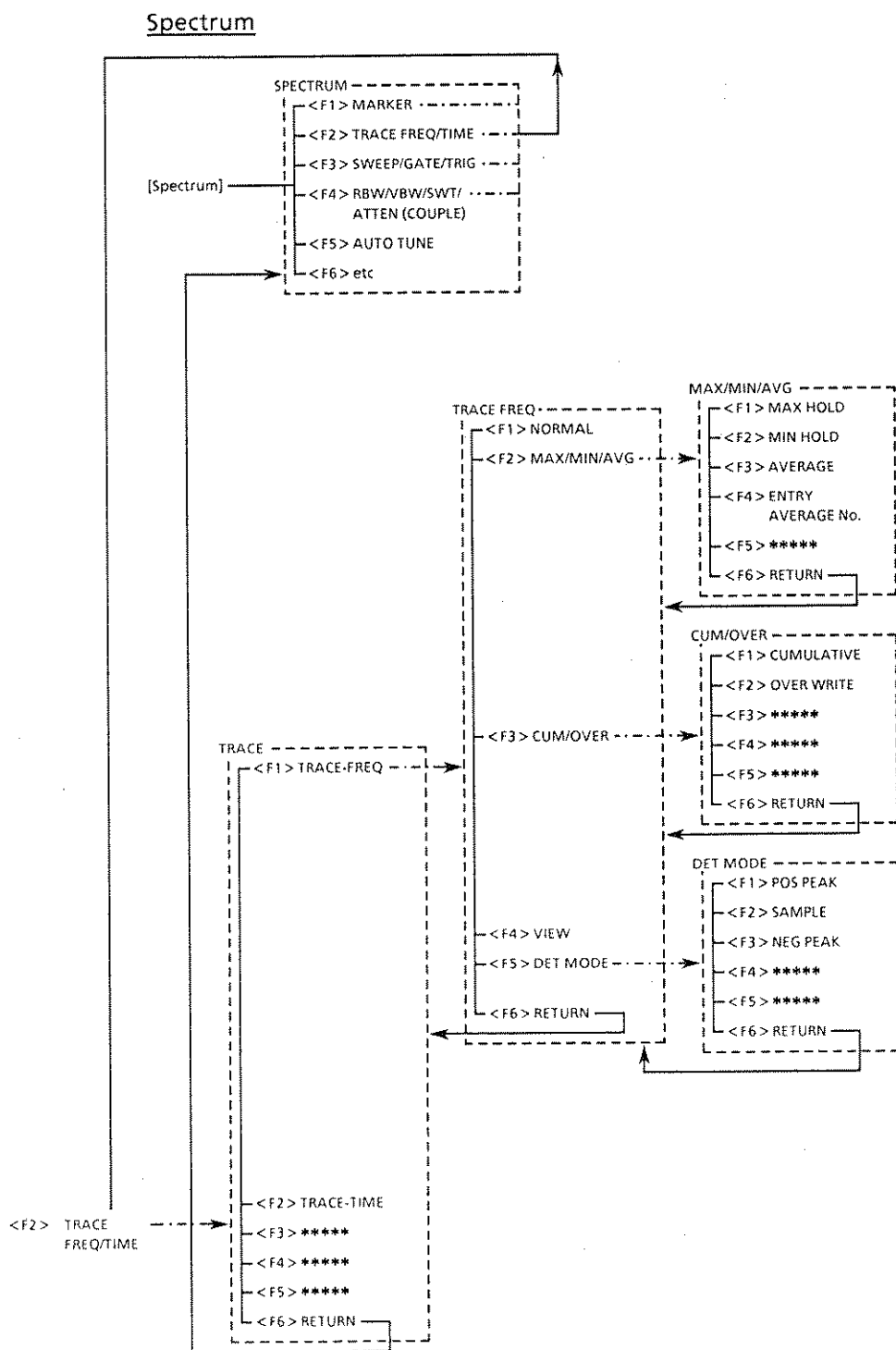

Example: Set the frequency domain display mode to average value AVG (number of averagings: 8).

Step	Key operation	Description
1	Spectrum	Displays page 1 of the SPECTRUM function keys menu.
2	[TRACE FREQ/TIME] F2 [TRACE FREQ] F1	Displays the TRACE function keys menu. Selects the frequency domain mode and displays the TRACE FREQ function keys menu.
3	[MAX/MIN/AVG] F2 [AVERAGE] F3	Displays the MAX/MIN/AVG function keys menu. Selects average value measurement.
4	[ENTRY AVERAGE NO] F4 8 Enter [RETURN] F6	Sets the number of averagings to 8. Returns to the TRACE FREQ function keys menu.

4.4.7 Time domain delay time, time span, expansion mode, and display mode setting

This paragraph describes time domain delay time, time span, expansion mode, and display mode setting.

- Delay time DELAY TIME

The delay time is the time from the sweep trigger point to the beginning of screen display. The pretrigger and post trigger time relationship at delay time setting is shown below.

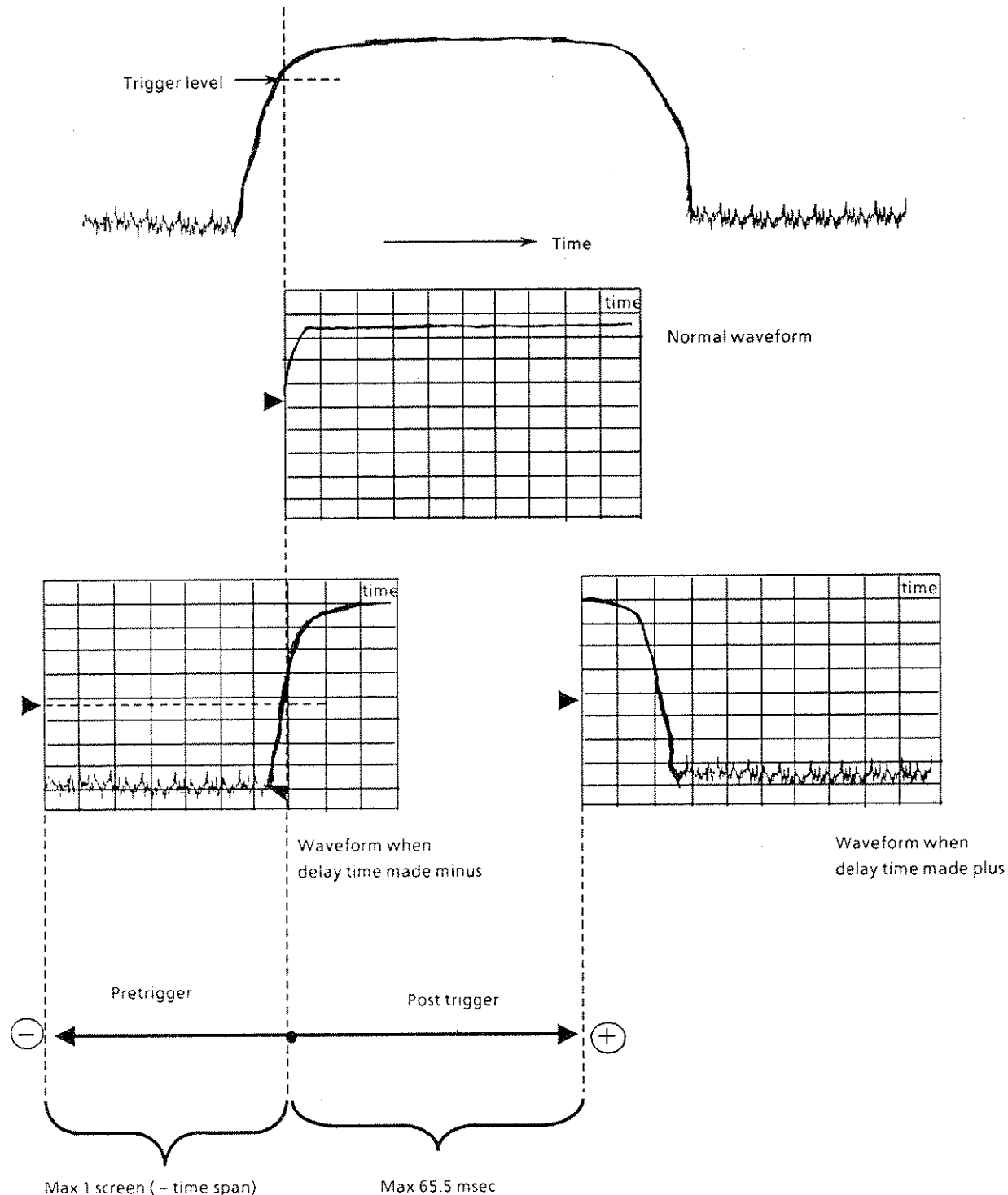

Waveform observation using delay time (video trigger used)

- Time span TIME SPAN

Time span is the time from the beginning to the end of screen display.

- Screen display expansion mode EXPAND MODE

Part of the screen display can be expanded. The following items are set:

Expansion start position ZONE START, expansion width ZONE SPAN, expansion width on/off ZONE ON/OFF, expansion on/off EXPAND ON/OFF

Note : ZONE START and ZONE SPAN can be set at anytime, regardless of the ZONE ON/OFF and EXPAND ON/OFF settings.

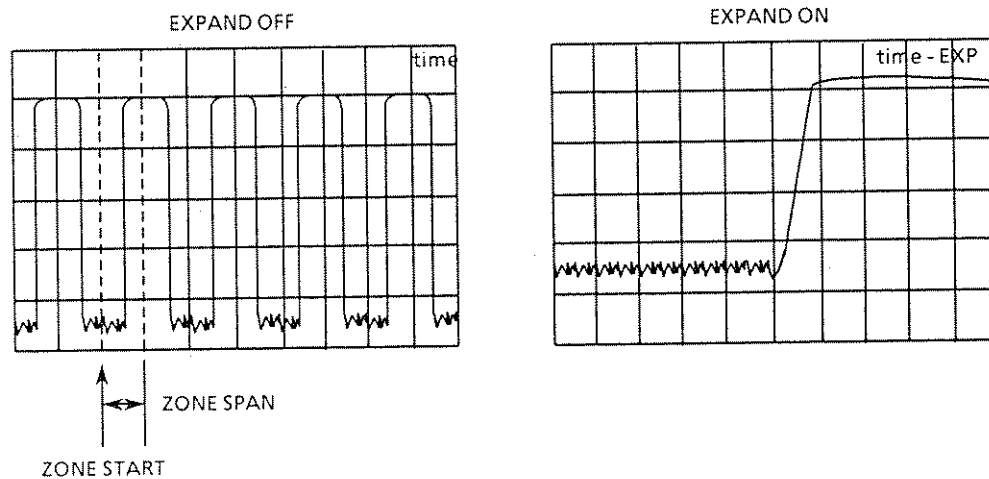

- Display mode

The display mode can be selected from the following:

NORMAL, maximum value MAX (MAX HOLD)/minimum value MIN (MIN HOLD)/average value AVG (AVERAGE), dot [measurement point] cumulative display CUM (CUMULATIVE)/trace [measurement line] overwrite OVER (OVERWRITE), sweep stop VIEW

Note : For average value measurement, see the Note in paragraph 4.4.6.

- The detection mode becomes sample point instantaneous value SAMPLE.

(1) Ranges and initial values

Delay time

Pretrigger : — time span to 0 s (step: 1 measurement point)
 Post trigger : 0 s to 65.5 ms (step: 1 μ s)
 Initial value : 0 s

Time span

Number of data points NORMAL : 50, 100 to 900 μ s (high-order 1 digit setting)
 1 ms to 1000 s (high-order 2 digits setting)
 Number of data points DOUBLE : 100, 200 to 800 μ s (high-order 1 digit setting)
 1 ms to 1000 s (high-order 2 digits even number setting)
 Initial value : 200 ms

Expansion mode

ZONE START	— 1000 s to 65.5 ms	Initial value : 0 sec
ZONE SPAN	50 μ s to 1000 s	Initial value : 200 ms
ZONE	ON, OFF	Initial value : OFF
EXPAND	ON, OFF	Initial value : OFF

Display mode :	NORMAL, MAX, MIN, AVG, CUM, OVER	Initial value : NORMAL
Average value setting (AVERAGE) :	ON, OFF	Initial value : OFF
Number of averagings (AVERAGE NO) :	2, 4, 8, 16, 32, 64, 128, 256	Initial value : 8

(2) Data input

The delay time, time span, expansion mode, and number of averagings data can be input in any of the following ways:

- Setting by ten-key pad [.] [+ / -] [0] to [9] and unit key [sec] [msec] [μ sec] or [Enter] key
- Setting by rotary knob
- Setting by Step/Select [\uparrow] [\downarrow] key

Other data is input by function keys menu. (See Appendix A.)

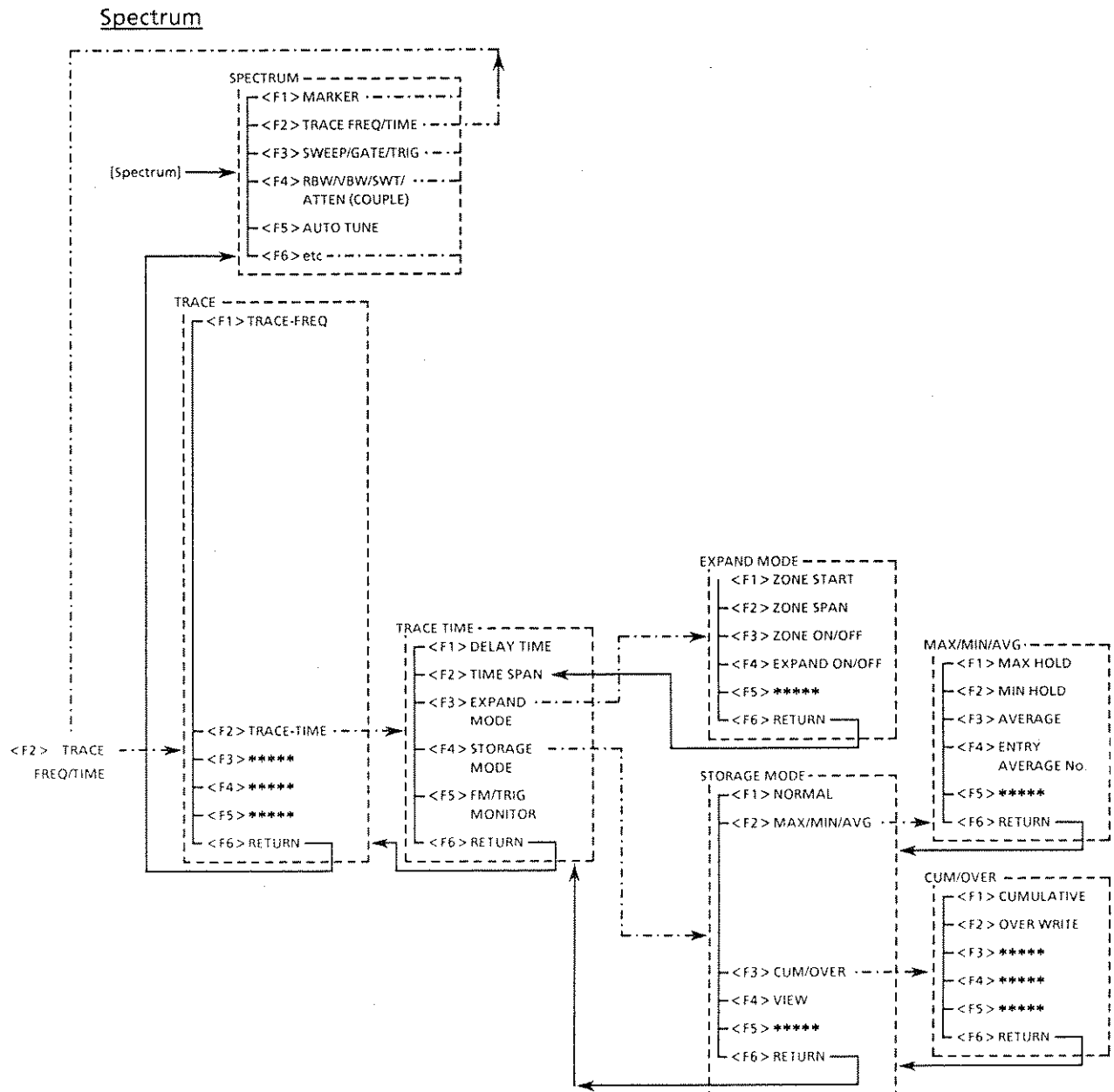

Example : See Example 2 of paragraph 4.4.8 (3).

4.4.8 Zone marker sweep, input signal gate, and sweep trigger signal setting (SWEEP/GATE/TRIG)

This paragraph describes sweep, input signal gate, and sweep trigger setting.

- Sweep mode

Continuous sweep ([Continuous] panel key) or single sweep ([Single] panel key) is selected by front panel key.

In the Single sweep mode, "SGL SWP" is displayed at the top right of the screen.

- Zone marker sweep

High-speed measurements can be made by sweeping only the inside of the frequency domain zone marker.

ZONE SWEEP ON/OFF

- Signal tracking

The frequency of the maximum level signal in the frequency domain zone marker is moved about the zone marker at each sweep. TRACKING ON/OFF

- Input signal gate

To measure the spectrum at burst wave input signal burst ON, only the input signal at burst ON is gated and input to the measurement circuit based on the VIDEO or EXT trigger signal. (See item (3).)

The following items are set:

GATE ON/OFF, gate delay time GATE DELAY, gate width GATE LENGTH, gate zone end setting GATE END INT/EXT

Note : If GATE END: EXT, the value set at GATE LENGTH is invalid.

- Sweep start trigger

The trigger modes are divided into free running and trigger TRIG FREE-RUN/TRIGGERED.

In the TRIGGERED mode, "TRIGGERED" is displayed at the top right of the screen.

When the trigger is selected, trigger source, trigger level, and trigger slope are set as shown below.

1. Trigger source TRIGGER SOURCE

- a. Input waveform after detection VIDEO

Note : When time domain is used, the VIDEO trigger level can be easily set as shown in the figure below.

The trigger level is indicated by the ► trigger level indicator at the left side of the screen.

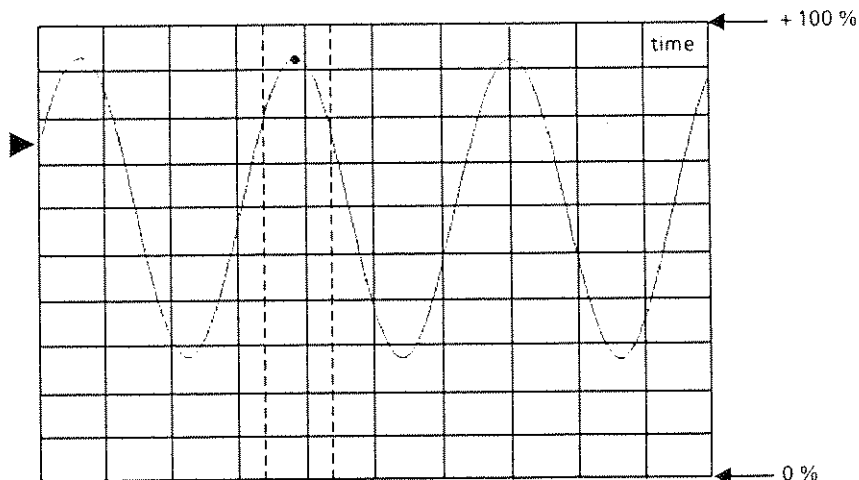

- b. Power line LINE
- c. External signal EXT

An external signal with a 10 μ s or wider pulse width is input at rear panel connector Trigger Input 1 (± 10 V) or Input 2 (TTL).

- d. Input video signal sync signal TV

This signal can be selected and set from the following:

NTSC/PAL system

Trigger sync signal

Vertical sync signal V-SYNC

Horizontal sync signal (even number fields) H-SYNC (EVEN)

Horizontal sync signal (odd number fields) H-SYNC (ODD)

Horizontal sync signal line number ENTRY H-SYNC No.

Note : TV trigger operates normally when all the conditions [time domain, Lin scale, RBW 3 MHz, VBW 3 MHz, input signal peak level at least 50 % higher than reference level] are satisfied.

- 2. Trigger level TRIG LEVEL

Note : For FREE RUN, LINE, and EXT (INPUT 2), TRIGGER LEVEL setting is unnecessary.

- 3. Trigger slope TRIG SLOP

Rising edge RISE or falling edge FALL is selected.

Note : For LINE trigger, TRIGGER SLOPE setting is unnecessary.

(1) Ranges and initial values

Sweep mode :	Continuous, Single	Initial value	Continuous
ZONE SWEEP :	ON, OFF	Initial value	OFF
TRACKING :	ON, OFF	Initial value	OFF
GATE :	ON, OFF	Initial value	OFF
GATE DELAY :	0 to 65.5 ms (step : 1 μ s)	Initial value	0 s
GATE LENGTH :	20 μ s to 65.5 ms (step : 1 μ s, GATE END : INT)	Initial value	1 ms
GATE END :	INT, EXT	Initial value	INT
TRIGGER :	FREE RUN, TRIGGERED	Initial value	FREE RUN
TRIG SOURCE :	VIDEO, LINE, EXT, TV	Initial value	VIDEO
TRIG SOURCE (EXT) :	INPUT 1 (± 10 V), INPUT 2 (TTL)	Initial value	INPUT 1
TRIG SOURCE (TV) :	NTSC, PAL	Initial value	NTSC
TRIG SOURCE (TV SYNC) :	V-SYNC, H-SYNC (EVEN)/H-SYNC (ODD), ENTRY H-SYNC No.	Initial value	V-SYNC
ENTRY H-SYNC No. :	NTSC EVEN	9 to 262	
	NTSC ODD	10 to 263	
	PAL EVEN	5 to 310	
	PAL ODD	6 to 310	
		Initial value	ODD 10
TRIGGER LEVEL :	VIDEO trigger	- 100 to +100 % (step : 1 %)	
	EXT (INPUT1) trigger	- 10.0 to +10.0 V (step : 0.1 V)	
		Initial value	0 %
TRIGGER SLOPE :	RISE, FALL	Initial value	RISE

(2) Data input

Data can be input in any of the following ways:

- Setting by ten-key pad [.] [+ / -] [0] to [9] and unit key [MHz/V/sec] [kHz/mV/msec] [Hz/ μ V/ μ sec] or [Enter] key
- Setting by rotary knob
- Setting by Step/Select [\uparrow] [\downarrow] key

Other data are input by function keys menu. (See Appendix A.)

Spectrum

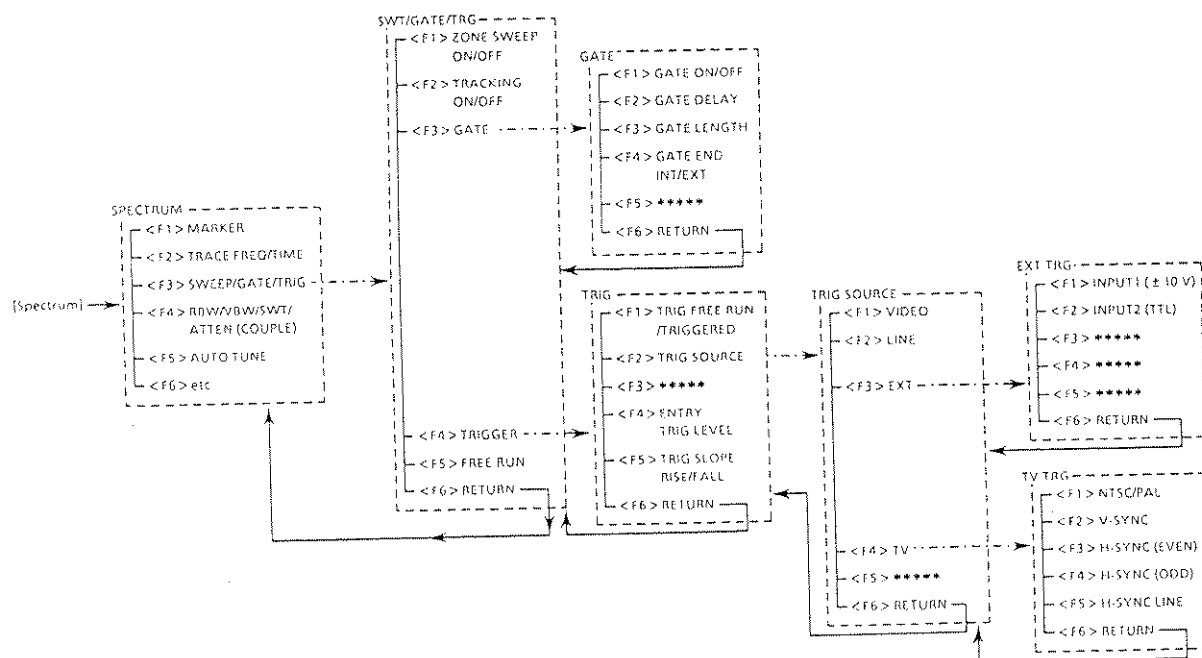

(3) Input signal gate function

(a) General

The gate function is a sweep mode which turns the waveform data display on and off by the gate control signal created in the MS8604A based on an external signal (Trigger Input 1 only) or video trigger signal.

Since the timing to display a spectrum waveform can be set using this mode, it is possible to analyze only the spectrum when the burst wave signal is set to ON.

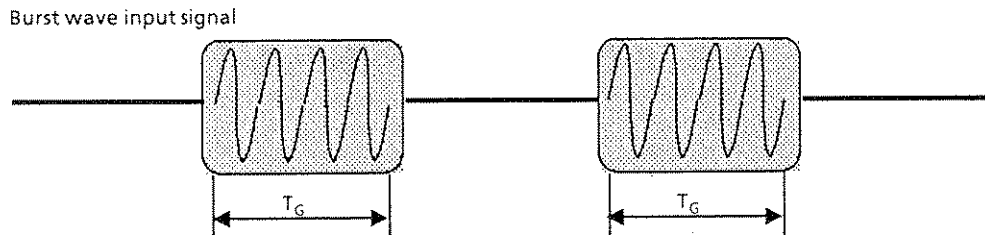

If the spectrum of the above burst wave is analyzed as it is,

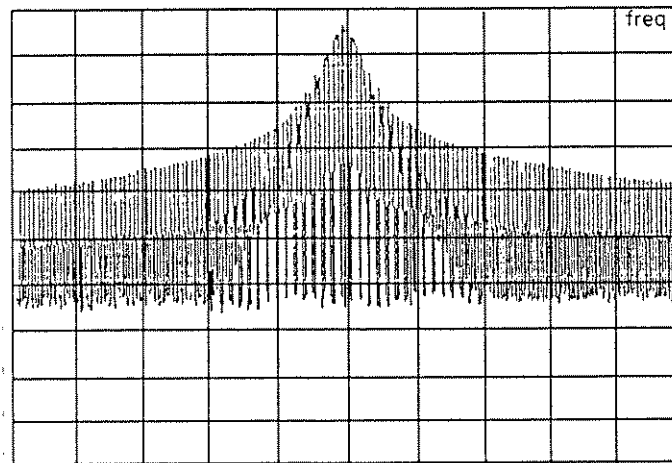

The spectrum spread by the positive leading edge or negative leading edge of the burst wave prevents the spectrum from being observed with the burst set to ON.

If the spectrum can be analyzed only during the gate time of T_G ,

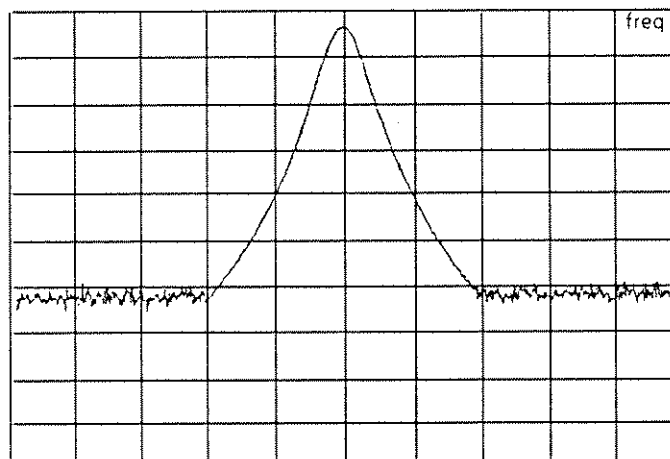

Only the spectrum when the burst is set to ON is displayed.

When the gate function is executed, the sweep runs in the FREE RUN mode and only the waveform data validated by the gate control signal is refreshed. If the sweep period is not synchronous with the gate control signal, a perfect-shaped trace can be obtained by increasing the number of sweep repetitions.

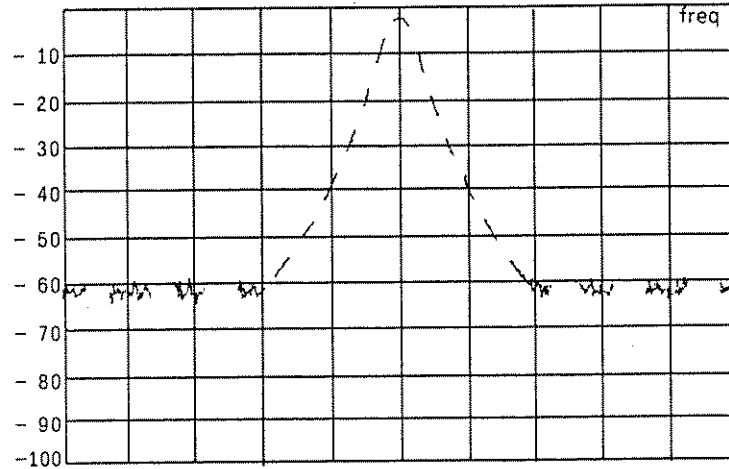

Fewer Sweep Repetitions

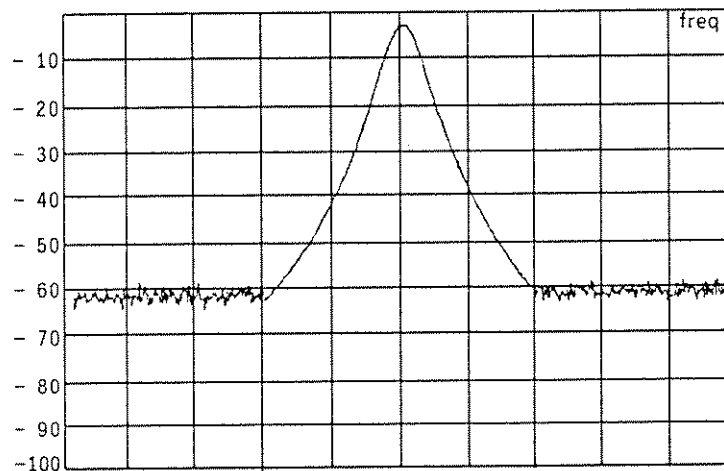

More Sweep Repetitions

Example of Frequency Spectrum Measurement on Burst Signal

(b) Creating a gate control signal

If the point where an external trigger signal (only EXT Input 1) or a video trigger signal is triggered is assumed to be the reference position, the gate control signal remains ON over the period from the point immediately after the GATE DELAY time has elapsed from the reference position, to the time point set by the GATE LENGTH, or to the time reset by a trigger signal.

- GATE END: When INT is selected

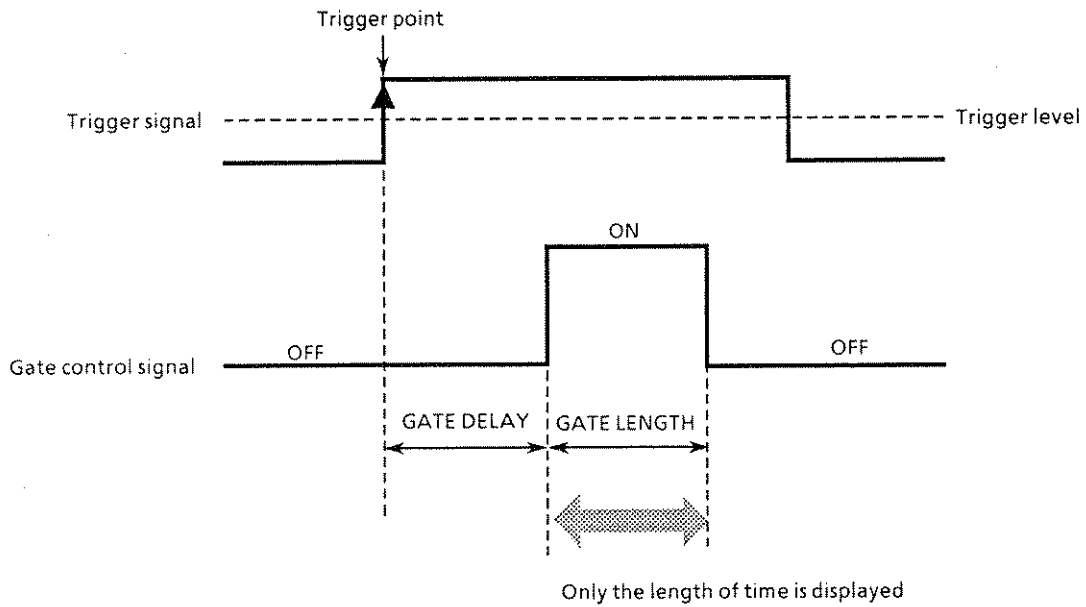

- GATE END: When EXT is selected

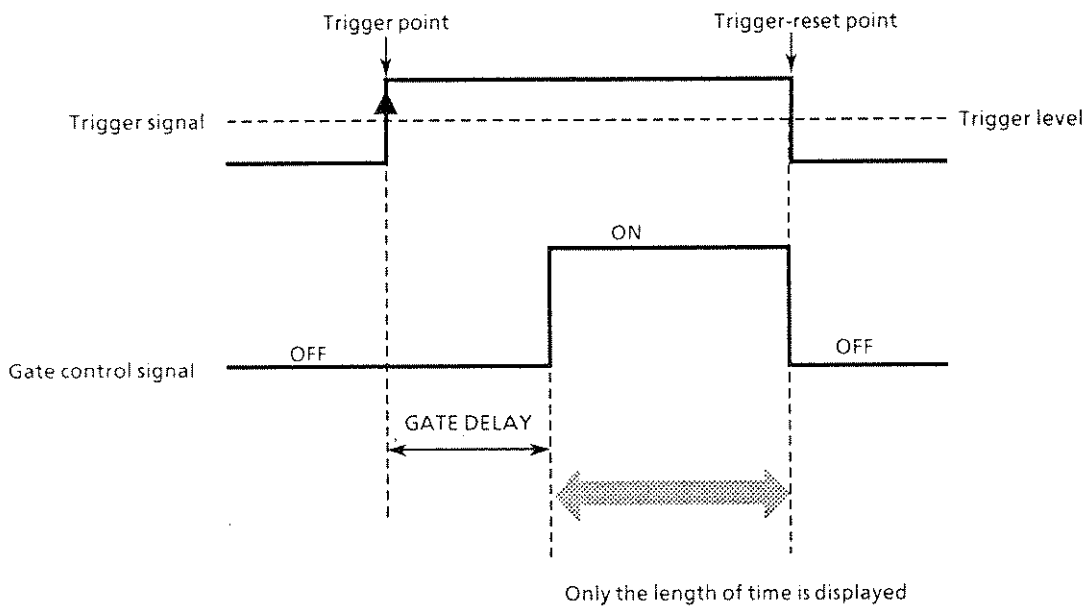

The time domain mode facilitates setting the time for the gate control signal. The following shows an example of how to use the gate function for which time domain is available.

Step	Procedure
------	-----------

- 1 Input the following signals to the MS8604A.

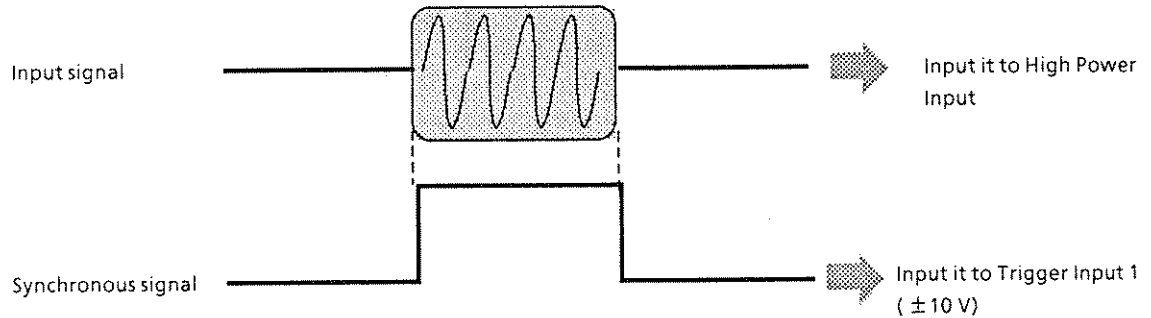

- 2 Display the waveform in the time domain mode. Synchronize the input signal by setting the trigger mode to TRIGGERED and the trigger source to EXT (INPUT 1).

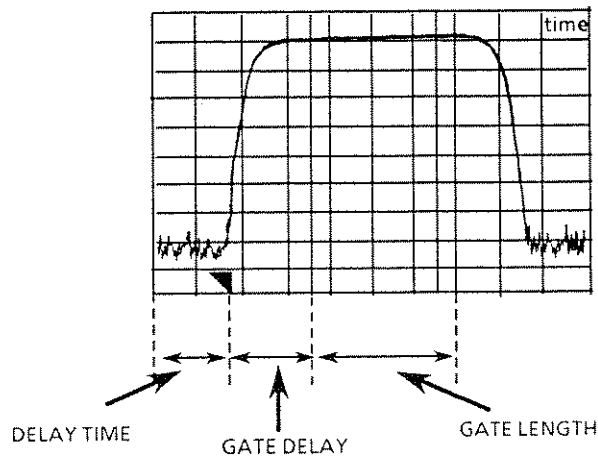

- 3 Set the GATE to ON, and vertical lines should appear at the positions of GATE DELAY and GATE LENGTH. Set the GATE DELAY and GATE LENGTH to appropriate positions while observing the waveform.

Step

Procedure

- 4 Set the frequency domain, and the trigger mode runs in FREE RUN and the waveform data is displayed only for the time set by GATE LENGTH.

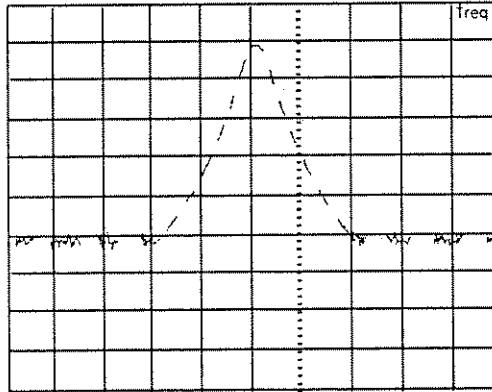

Notes: ① Since the output is delayed compared to the positive leading edge of the input waveform when the resolution bandwidth (RBW) is narrower, noise such as spikes may appear on the trace. To prevent these from appearing, set GATE DELAY and GATE LENGTH to values that satisfy the following conditions.

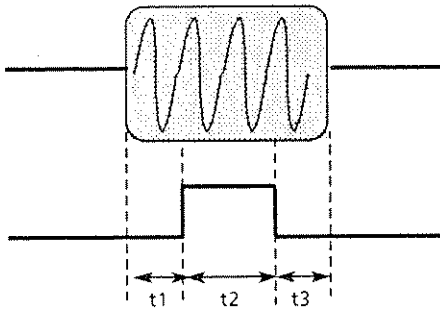

RBW	t1	t2	t3
1 kHz	$\cong 2 \text{ ms}$	$\cong 20 \mu\text{s}$	$\cong 1 \mu\text{s}$
3 kHz	$\cong 600 \mu\text{s}$		
10 kHz	$\cong 230 \mu\text{s}$		
30 kHz	$\cong 200 \mu\text{s}$		
100 kHz	$\cong 20 \mu\text{s}$		
300 kHz	$\cong 15 \mu\text{s}$		
1 MHz 3 MHz	$\cong 10 \mu\text{s}$		

- ② When the resolution bandwidth (RBW) is extremely narrow for the frequency span, some waveforms cannot be displayed correctly. Set each parameter so that the following conditions are satisfied.

$$\text{RBW} \geq \frac{\text{SPAN}}{\text{Number of data points (NORMAL 501 or DOUBLE 1002)}} \times 5$$

- ③ The GATE function can use a video trigger as a gate control signal. In this case, the gate control signal must be generated correctly so that a trigger can be normally set with the same RBW, VBW, and trigger level conditions at all frequencies within the frequency span observed in the frequency domain.

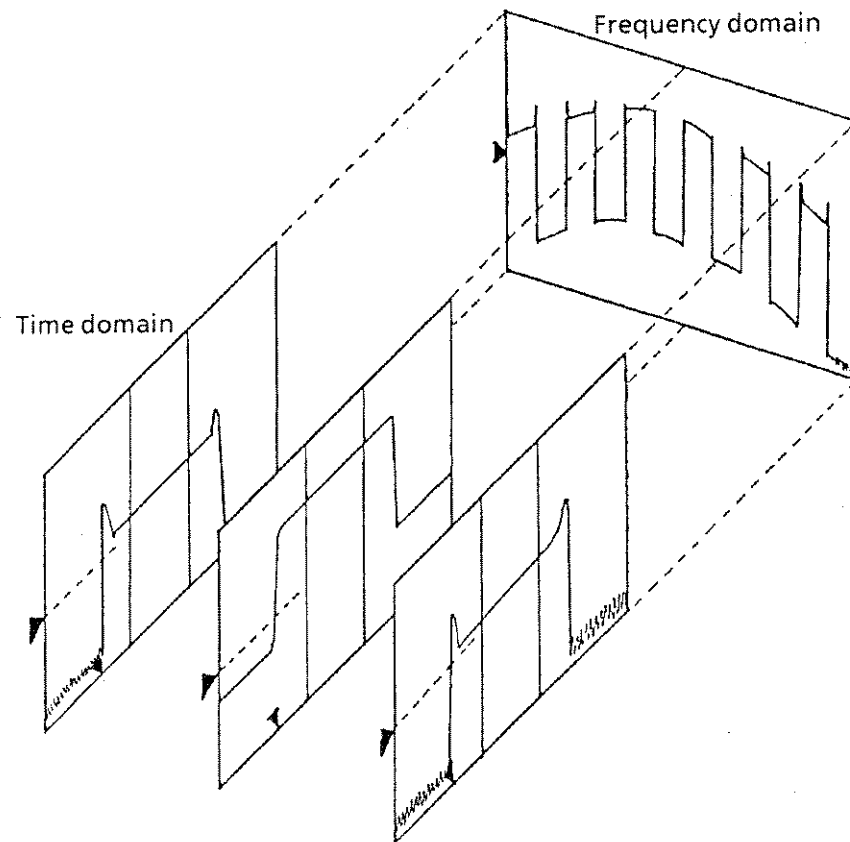

Example 1: Set VIDEO trigger to 30 % and TRIGGER SLOPE to RISE.

Step	Key operation	Description
1	Spectrum	Displays page 1 of the SPECTRUM function keys menu.
2	TRACE FREQ/TIME F2	Displays the TRACE function keys menu.
	TRACE TIME F2	Displays the TRACE TIME function keys menu.
	See paragraph 4.4.7 and display the VIDEO signal on the screen.	
3	RETURN F6	Returns to the TRACE function keys menu.
	RETURN F6	Returns to the SPECTRUM function keys menu.
4	SWEEP/GATE/TRIGGER F3	Displays the SWP/GATE/TRG function keys menu.
5	TRIGGER F4	Displays the TRIG function keys menu.
	TRIG FREE-RUN/TRIGGERED F1	Sets TRIGGERED.
6	TRIG SOURCE F2	Displays the TRIG SOURCE function keys menu.
	VIDEO F1	Sets VIDEO.
7	RETURN F6	Returns to the TRIG function keys menu.
	ENTRY TRIG LEVEL F4	
	3 0 Enter	Sets the trigger level to 30 %. (Check at the waveform on the screen.)
	TRIG SLOPE RISE/FALL F5	Sets TRIGGER SLOPE to RISE.

Example 2: Set the PDC burst wave rising characteristic. After setting trigger at Example 1, in time domain mode, set the delay time pre-trigger to 1 ms, time span to 10 ms, expansion mode (ZONE START: $-500 \mu\text{s}$, ZONE SPAN: 1 msec), and expansion on/off and observe the expanded waveform and normal waveform.

Step	Key operation	Description
1	Spectrum	Displays page 1 of the SPECTRUM function keys menu.
2	TRACE FREQ/TIME F2 TRACE TIME F2	Displays the TRACE function keys menu. Selects time domain mode and displays the TRACE TIME function keys menu.
3	TIME SPAN F2 1 0 msec	Sets the time span to 10 ms.
4	DELAY TIME F1 +/- 1 msec	Sets the delay time to -1 ms (pretrigger).
5	EXPAND MODE F3 ZONE SPAN F2 1 msec ZONE START F1 +/- 5 0 0 μsec	Displays the EXPAND MODE function keys menu. Sets ZONE SPAN to 1 ms. Sets ZONE START to $-500 \mu\text{s}$.
6	EXPAND ON/OFF F4 EXPAND ON/OFF F4	Sets EXPAND to ON and displays an expanded waveform. Sets EXPAND to OFF and displays the normal waveform. Expanded waveform and normal waveform are compared and studied by repeating step 6.

4.4.9 Resolution bandwidth (RBW), video bandwidth (VBW), sweep time (SWT), and RF input attenuator (ATTEN) setting

This paragraph describes the following settings:

- Resolution bandwidth RBW
- Video bandwidth VBW
- Sweep time SWT
- RF input attenuator ATTEN
- AUTO VBW/RBW setting ratio VB/RB RATIO

(1) Ranges and initial values

RBW: MANUAL, AUTO, BW/SWT AUTO Initial value AUTO
MANUAL: 10 Hz to 3 MHz (1-3 sequence)

VBW: MANUAL, AUTO, OFF, ENTRY FREQ-VB/RB RATIO, BW/SWT AUTO Initial value AUTO
MANUAL: 1 Hz to 3 MHz (1-3 sequence)
ENTRY FREQ-VB/RB RATIO: 0.0001 to 100 Initial value 1

SWT: MANUAL, AUTO, BW/SWT AUTO Initial value AUTO
MANUAL:

Lower limit value

Frequency domain (sweep time) Significant digits 2

20 ms (frequency band 0, number of data points NORMAL)

50 ms (frequency band 0, number of data points DOUBLE)

100 ms (including frequency band 1 -, 1 +, frequency span \leq 3 GHz)

200 ms (including frequency band 1 -, 1 +, frequency span $>$ 3 GHz)

Time domain (time span)

Number of data points NORMAL:

50 μ s

100 to 900 μ s Significant digits 1

1 ms to 1000 s Significant digits 2

Number of data points DOUBLE:

100 μ s

200 to 800 μ s Significant digits 1, even number only

1 ms to 1000 s Significant digits 2, even number only

Upper limit

1000 s

ATTEN: MANUAL, AUTO
MANUAL: 20 to 75 dB (step: 5 dB) (RF input: High)
MANUAL: 0 to 55 dB (step: 5 dB) (RF input: Low)

(2) Data input

Data is input in any of the following ways:

- Setting by ten-key pad [.] [0] to [9] and units key [GHz/dBm/dB] [MHz/V/sec] [kHz/mV/msec] [Hz/ μ V/ μ sec] or [Enter] key
- Setting by rotary knob
- Setting by Step/Select [\uparrow] [\downarrow] key

Other data is input by function keys menu. (See Appendix A.)

Spectrum

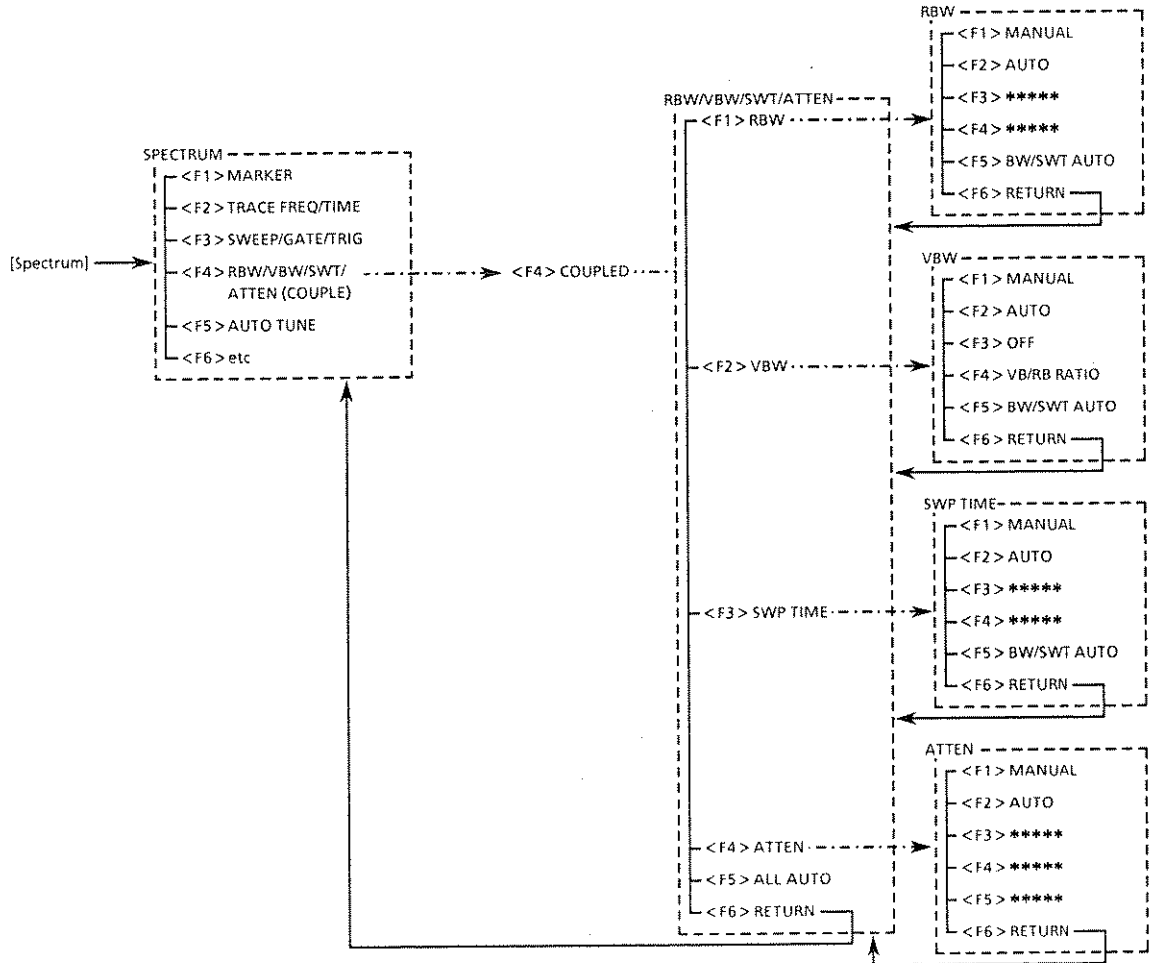

Notes : 1. In the AUTO mode, RBW, VBW, and SWT are set as shown below.

The frequency span, RBW, VBW, and Swp Time Auto setting state is shown below.

Frequency span (Hz)	RBW (Hz)	VBW (Hz)	Swp Time (sec)
100 to 150	10	$VBW = R \times RBW$ Where, VBW lower limit value is 1 Hz and upper limit value is 3 MHz.	$RBW \leq VBW$ $Swp\ Time = K \times \frac{SPAN}{RBW^2}$ $RBW > VBW$ $Swp\ Time = K \times \frac{SPAN}{RBW \times VBW}$
151 to 1 k	30		
1.01 k to 10 k	100		
10.1 k to 20 k	300		
20.1 k to 100 k	1 k		
101 k to 200 k	3 k		
201 k to 2 M	10 k		
2.01 M to 20 M	30 k		
20.1 M to 200 M	100 k		
201 M to 1 G	300 k		
1.01 G to 8.5 G	1 M	$R:FREQ-VB/RB\ RATIO$ setting (0.0001 to 100) (Initial value: 1)	$K = 3$ (AUTO SWT: SLOW) $K = 2$ (AUTO SWT: FAST) (By system setting)

- If RBW is Auto, the value corresponding to the frequency span is set.
- If VBW is Auto, the value is set according to the RBW and (FREQ-VB/RB RATIO) setting.
- If Swp Time is Auto, the value is set according to the frequency span, RBW, VBW, and AUTO SWT mode settings. For the AUTO SWT mode, see paragraph 4.4.14.

2. ATTEN is set as follows:

Reference level and input attenuator

RF input : High

REF LEVEL (dBm)	ATTEN (dB) (Auto)
+45.1 to +50.0	65
+40.1 to +45.0	60
+35.1 to +40.0	55
+30.1 to +35.0	50
+25.1 to +30.0	45
+20.1 to +25.0	40
+15.1 to +20.0	35
+10.1 to +15.0	30
-54.9 to +10.0	25
-80.0 to -55.0	20

REF LEVEL (dBm)	ATTEN (dB) (Manual)
+45.1 to +50.0	60 to 75
+40.1 to +45.0	55 to 75
+35.1 to +40.0	50 to 75
+30.1 to +35.0	45 to 75
+25.1 to +30.0	40 to 75
+20.1 to +25.0	35 to 75
+15.1 to +20.0	30 to 75
+10.1 to +15.0	25 to 75
-25.0 to +10.0	20 to 75
-30.0 to -25.1	20 to 70
-35.0 to -30.1	20 to 65
-40.0 to -35.1	20 ~to 60
-45.0 to -40.1	20 to 55
-50.0 to -45.1	20 to 50
-55.0 to -50.1	20 to 45
-60.0 to -55.1	20 to 40
-65.0 to -60.1	20 to 35
-70.0 to -65.1	20 to 30
-75.0 to -70.1	20 to 25
-80.0 to -75.1	20

RF input : Low

REF LEVEL (dBm)	ATTEN (dB) (Auto)
+25.1 to +30.0	45
+20.1 to +25.0	40
+15.1 to +20.0	35
+10.1 to +15.0	30
+5.1 to +10.0	25
+0.1 to +5.0	20
-4.9 to +0.0	15
-9.9 to -5.0	10
-74.9 to -10.0	5
-100.0 to -75.0	0

REF LEVEL (dBm)	ATTEN (dB) (Manual)
+25.1 to +30.0	40 to 55
+20.1 to +25.0	35 to 55
+15.1 to +20.0	30 to 55
+10.1 to +15.0	25 to 55
+5.1 to +10.0	20 to 55
+0.1 to +5.0	15 to 55
+4.9 to +0.0	10 to 55
+9.9 to -5.0	5 to 55
-45.0 to -10.0	0 to 55
-50.0 to -45.1	0 to 50
-55.0 to -50.1	0 to 45
-60.0 to -55.1	0 to 40
-65.0 to -60.1	0 to 35
-70.0 to -65.1	0 to 30
-75.0 to -70.1	0 to 25
-80.0 to -75.1	0 to 20
-85.0 to -80.1	0 to 15
-90.0 to -85.1	0 to 10
-95.0 to -90.1	0 to 5
-100.0 to -95.1	0

3. All settings other than ATTEN can be set to AUTO mode by RBW, VBW, and SWT menus [BW/SWP AUTO : F5] key.
RBW, VBW, SWT, and ATTEN can be set to AUTO mode by RBW/VBW/SWT/ATTEN menu [ALL AUTO : F5] key.
4. When RBW, VBW, and SWT manual setting is unsuitable, UNCAL is displayed at the top left of the screen.
5. To make RBW, VBW, and Sweep time (Time span) a different value in the frequency domain and time domain modes, set RBW/VBW/SWT MODE to INDEPENDENT at SYSTEM setup. (See paragraph 4.4.14.) ATTEN cannot be set to a different value.
Since the setting range is different in the frequency domain (sweep time) and time domain (time span) modes even when set to the same value COMMON, setting to the same value as described below may not be possible.

Sweep time set to 300 ms in frequency domain mode.

↓

Changed to time domain mode and time span set to 100 μ s.

↓

Returned to frequency domain mode. --- Sweep time becomes minimum value 20 ms.

↓

Changed to time domain mode. --- Time span becomes 20 ms.

Example: Set RBW to 1 MHz, VBW to 10 kHz, SWT to 100 ms, and ATTEN to 50 dB.

Step	Key operation	Description
1	[Spectrum]	Displays page 1 of the SPECTRUM function keys menu.
2	[RBW/VBW/SWT/ATTEN] [F4]	Displays the RBW/VBW/SWT/ATTEN function keys menu.
3	[RBW] [F1] [1] [MHz]	Displays the RBW function keys menu. Sets RBW to 1 MHz.
4	[RETURN] [F6]	Returns to the RBW/VBW/SWT/ATTEN function keys menu.
5	[VBW] [F2] [1] [0] [kHz]	Displays the VBW function keys menu. Sets VBW to 10 kHz.
6	[RETURN] [F6]	Returns to the RBW/VBW/SWT/ATTEN function keys menu.
7	[SWP TIME] [F3] [1] [0] [0] [ms]	Displays the SWP TIME function keys menu. Sets SWT to 100 ms.
8	[RETURN] [F6]	Returns to the RBW/VBW/SWT/ATTEN function keys menu.
9	[ATTEN] [F4] [5] [0] [dB]	Displays the ATTEN function keys menu. Sets ATTEN to 50 dB.

4.4.10 Marker setting (MARKER)

This paragraph describes marker setting.

- Type of marker MARKER

[Normal NORMAL - - - zone marker ZONE]

In frequency domain mode, the frequency zone (zone width) ZONE WIDTH is set by two vertical broken lines. The current marker \blacklozenge moves to the peak level in the zone.

In time domain zone, the zone width is assumed to be 1 point (SPOT).

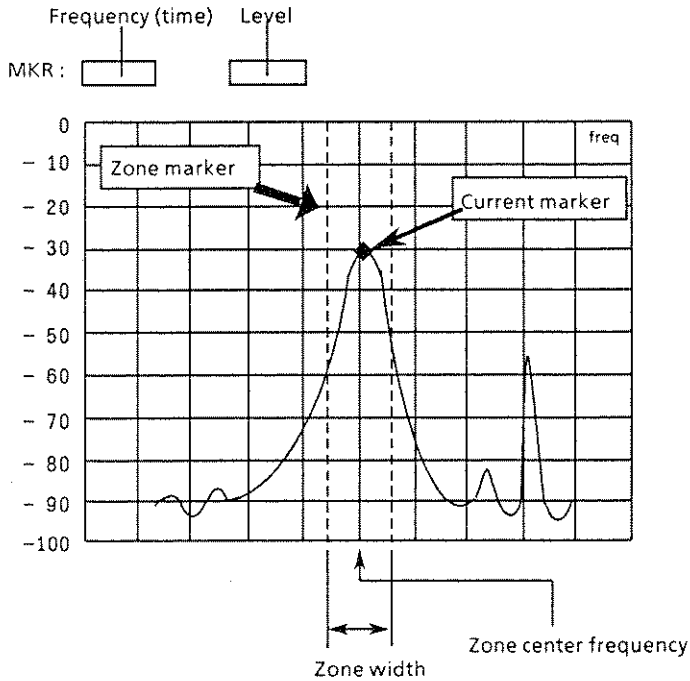

Spot marker (zone width: 1 point) example

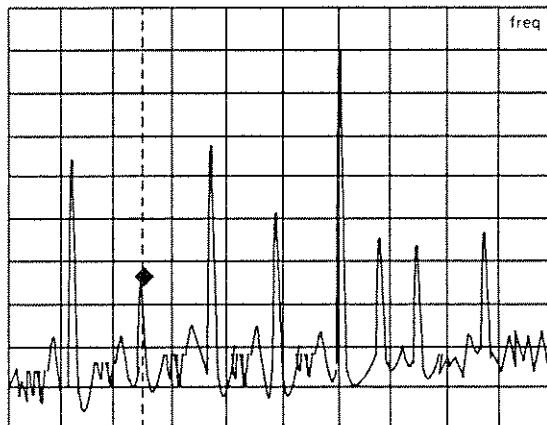

Zone width: 10 div example

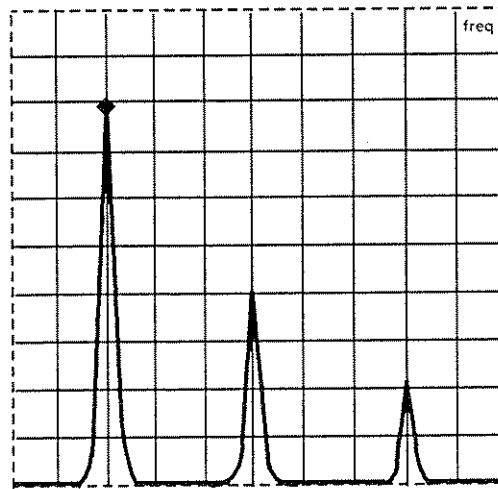

[Delta marker DELTA]

Displays the frequency difference and level difference between the reference marker \square (fixed at the current marker position when the delta mode was set) and current marker \blacklozenge . When Log/Lin scale is changed, the marker changes to the normal marker mode.

In the delta marker mode, zone marker position (center frequency or center time) setting by ten-key pad inputs the difference from the reference marker position.

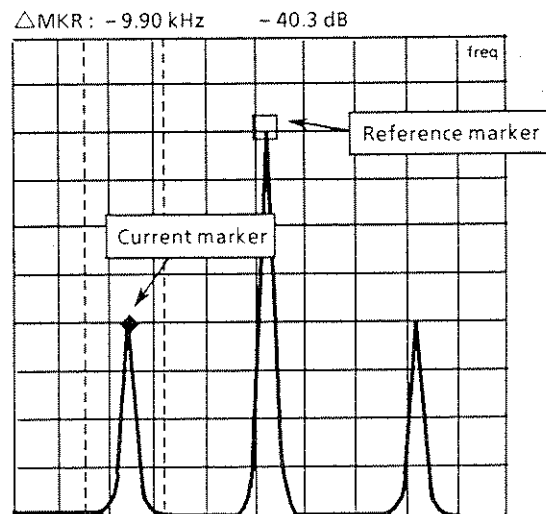

[Multi marker MULTI MKR (max 10 markers ◆ 1 to ◆ 10)]

HIGHEST 10 :

Automatically sets up to 10 markers to the peaks of the signal displayed on the screen in high level order.

The peak of the maximum level signal becomes the active marker and its frequency and level are displayed at the top left of the screen.

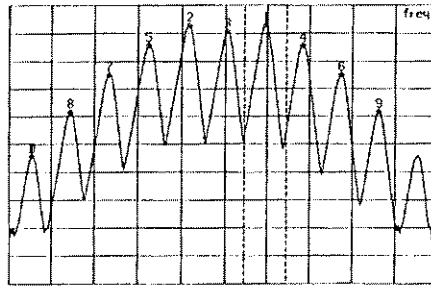

HARMONICS :

Automatically sets markers to the harmonics, with the maximum level signal in the zone marker as the fundamental wave.

It is ineffective when:

1. The fundamental wave and the second harmonic are within 1 div.
2. There is a non harmonic signal with a higher level within 1 div of each harmonic.

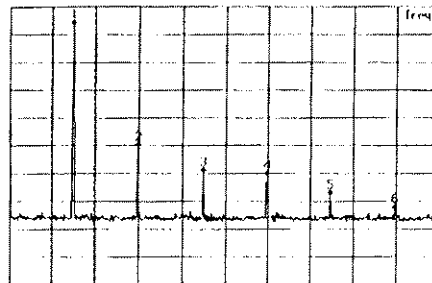

MANUAL SET :

Up to 10 markers can be set manually to arbitrary positions.
See the example of item (2).

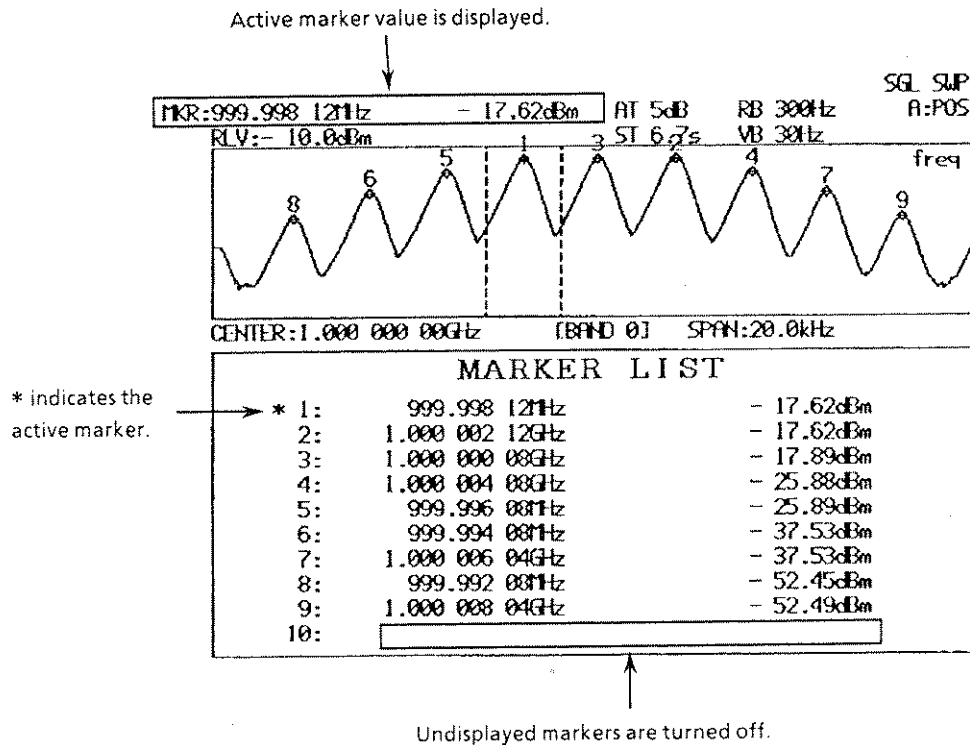

MKR LIST ON/OFF :

Lists the frequency (or time) and level of all the multi markers. A * at the left side of the numbers 1 to 10 indicates that the marker is an active marker. Inactive markers are not displayed.

- Marker position move PEAK SEARCH

The marker \blacklozenge can be moved to the positions shown below by pressing the function keys. The levels are detected sequentially by pressing the NEXT key repeatedly.

- Highest level position PEAK SEARCH,
- Next highest level position NEXT PEAK,
- Next highest level position at the right NEXT RIGHT PEAK,
- Next highest level position at the left NEXT LEFT PEAK,
- Minimum level position MIN DIP,
- Next minimum level position NEXT DIP

Notes : 1. When two or more points have the same level, the marker moves to the left end.

- When moving the marker by other than PEAK SEARCH, stop the sweep or set the zone width to SPOT (1 point). The reason for this is described below.
When the marker position is moved, the center frequency of the zone marker also moves to the marker point at that time. If sweep is performed at this time, the marker will move to the peak level in the zone marker.

[NEXT PEAK]

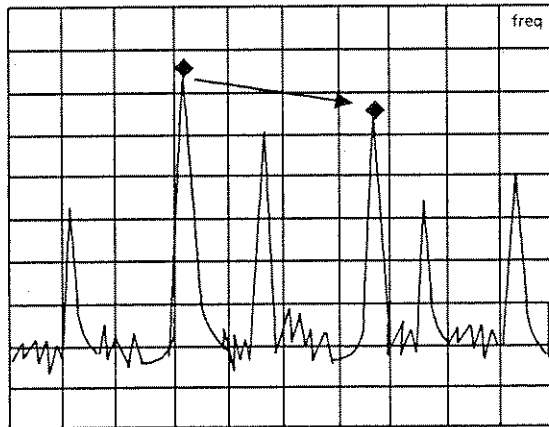

[MIN DIP] [NEXT DIP]

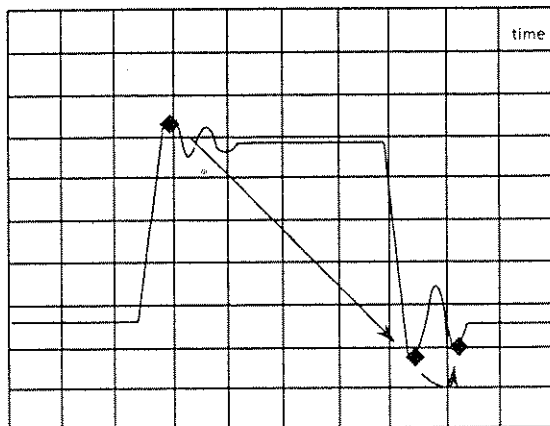

The small level dips are sequentially detected and the marker is moved by executing NEXT DIP search continuously.

[NEXT LEFT PEAK] and [NEXT RIGHT PEAK]

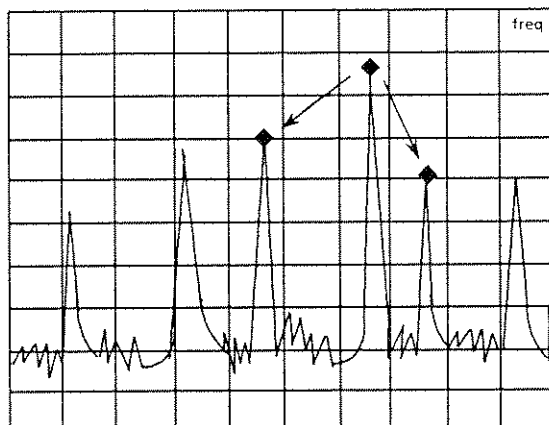

The adjacent peaks at the right or left are sequentially detected and the marker is moved by executing NEXT RIGHT PEAK search or NEXT LEFT PEAK search continuously.

- Marker value parameter setting MARKER →

The marker frequency or level can be set at the following parameters by pressing the function keys:
 Marker → center frequency MKR → CF, marker → reference level MKR → REF,
 marker → center frequency step value MKR → CF STEP, delta marker → span Δ MKR → SPAN,
 zone marker → span ZONE → SPAN
 In time domain mode, only MKR → REF is performed.

[MKR → CF] and [MKR → REF]

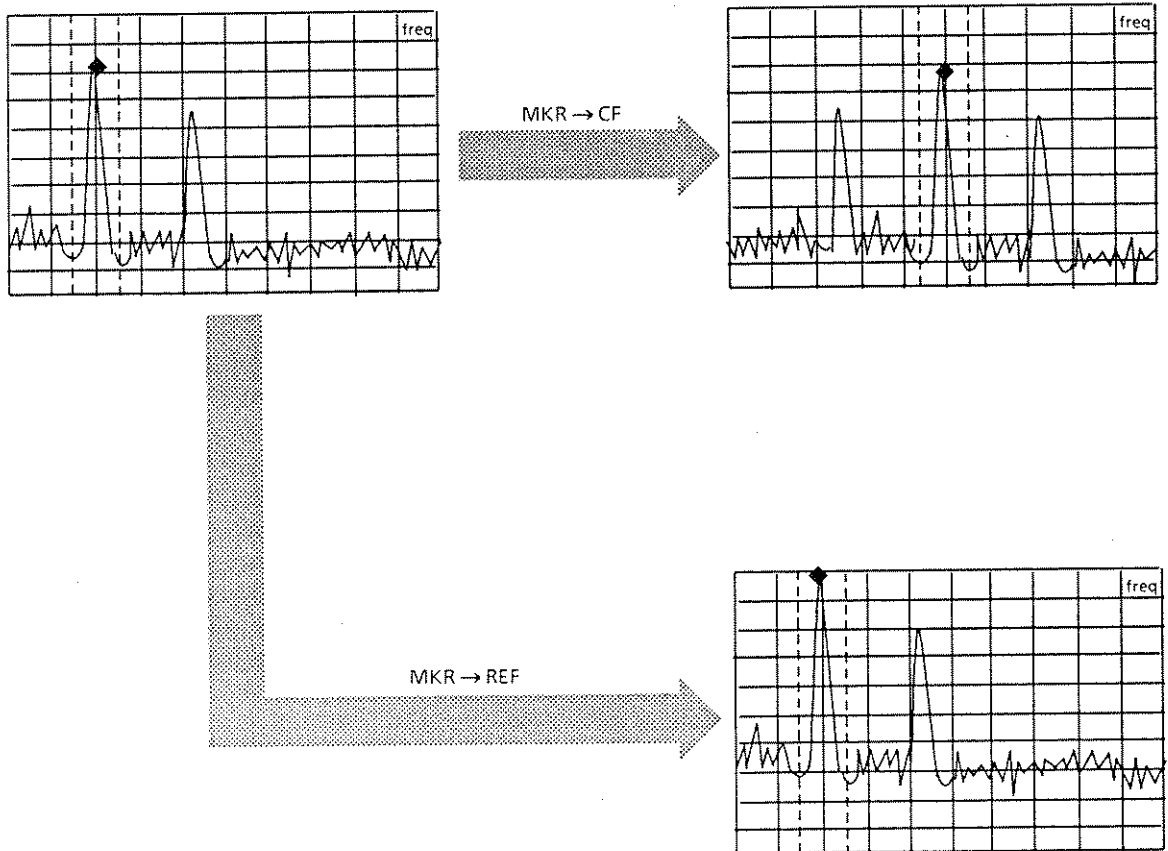

[ΔMKR → SPAN]

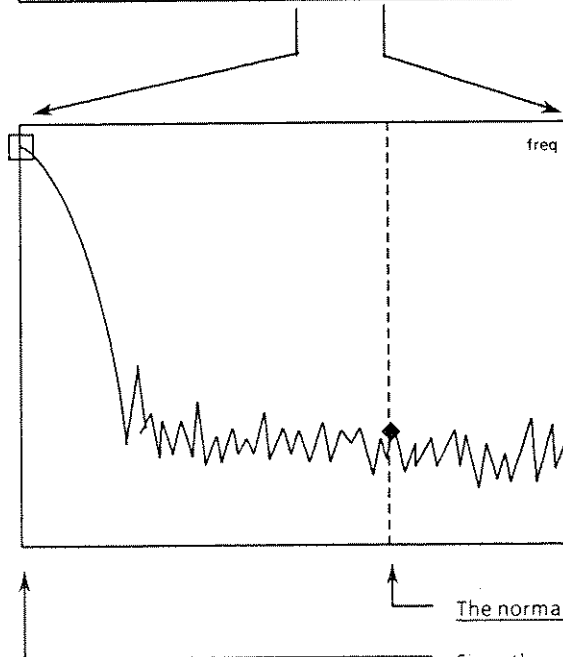
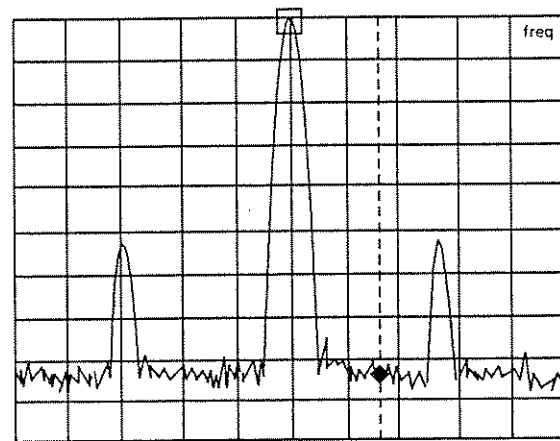

The normal marker position does not change.

Since the reference marker is fixed relative to the frequency, when the frequency span is changed, the reference marker moves to the left end.

[ZONE → SPAN]

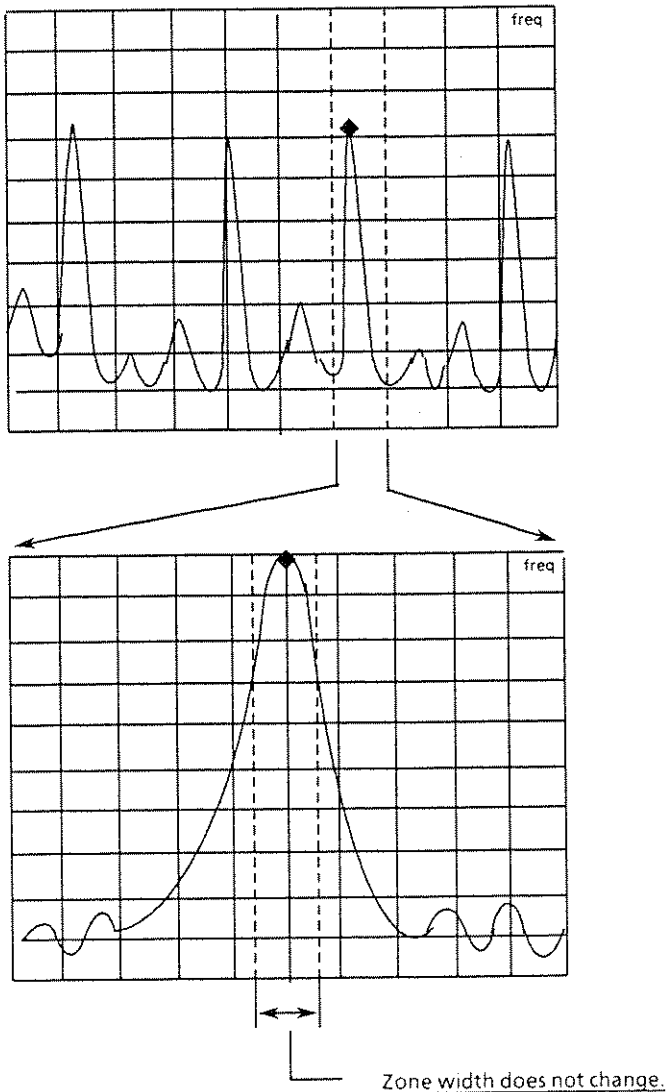

(1) Ranges and initial values

MARKER :	NORMAL, DELTA, MULTI MKR	Initial value	NORMAL
Zone marker center position :	Left end to right end of screen	Initial value	Center
ZONE WIDTH :	Manual, SPOT, 1 div, 2 div, 5 div, 10 div MANUAL : 1 point to frequency span (time domain mode: SPOT only)	Initial value	1 div
MULTI MKR :	HIGHEST 10, HARMONICS, MANUAL SET, OFF Manual marker : No.1 to No.10	Initial value	OFF
MARKER SEARCH :	PEAK SEARCH, NEXT PEAK, NEXT RIGHT PEAK, NEXT LEFT PEAK, MIN DIP, NEXT DIP	Initial value	PEAK SEARCH
MARKER → :	MKR → CF, MKR → REF, MKR → CF STEP, ΔMKR → SPAN, ZONE → SPAN	Initial value	MKR → CF
MULTI MARKER LIST :	ON, OFF	Initial value	OFF

(2) Data input

Data can be input in any of the following ways:

- Setting by ten-key pad [.] [0] to [9] and units key [GHz/dBm/dB] [MHz/V/sec] [kHz/mV/msec] [Hz/ μ V/ μ sec] or [Enter] key
- Setting by rotary knob
- Setting by Step/Select [\uparrow] [\downarrow] key

Other data is input by function keys menu. (See Appendix A.)

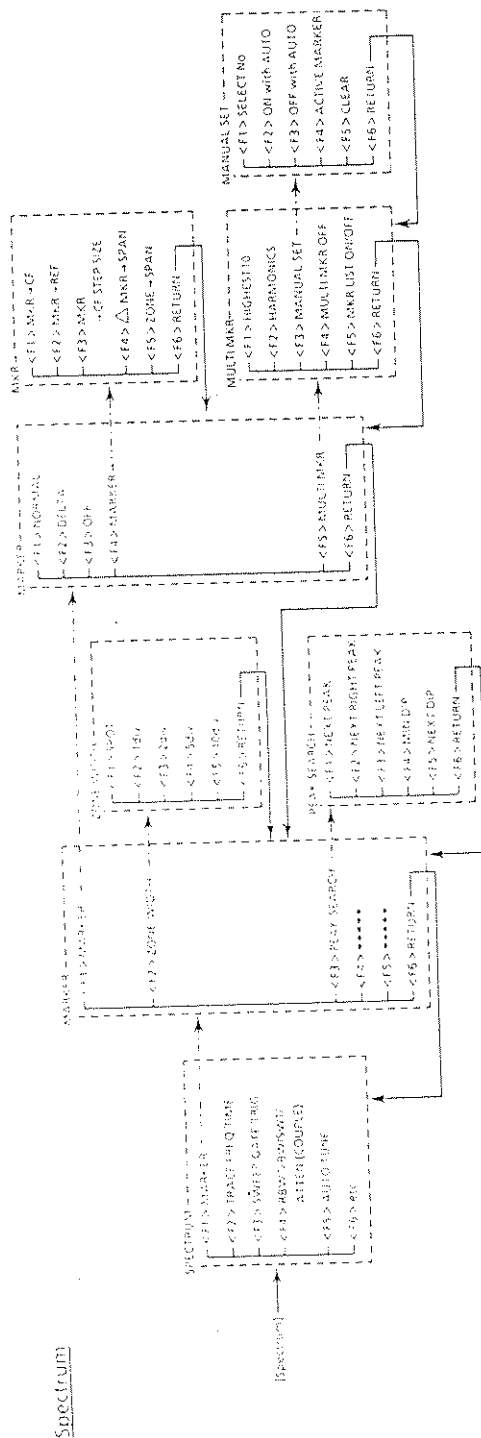

Example: Set 10 multi markers in 100 MHz steps between 100 MHz and 1000 MHz, turn on markers 1 to 5 (100 MHz to 500 MHz) and turn off markers 6 to 10 (600 MHz to 10900 MHz). Make marker 5 (500 MHz) the active marker ◆ and display the marker list. Thereafter, turn off the ON markers (markers 1 to 4 ◇) other than the active marker. (Active marker No.5 changes to 1.)
Finally, turn off the multi marker mode.

Step	Key operation	Description
1	Spectrum	Displays the SPECTRUM function keys menu.
2	See paragraph 4.4.3, etc. and set the start frequency to 0 MHz and the stop frequency to 1100 MHz, and input a suitable signal with a spectrum of that frequency range.	
3	MARKER F1 MARKER F1	Displays the MARKER function keys menu.
4	MULTI MKR F5	Displays the MULTI MKR function keys menu.
5	MANUAL SET F3	Displays the MANUAL SET function keys menu.
6	CLEAR F5	Clears all the previously set markers to prepare for multi marker setting.
7	SELECT No. F1 1 0 0 MHz ON with AUTO SELECT F2	Selects marker 1. Sets marker 1 to 100 MHz. Turns on marker 1 and makes it an active marker. (No.1 is set and SELECT No. is automatically shifted to No.2.)
8	Set markers 2 to 5 to 200 to 500 MHz ON markers respectively, the same as step 7. (Marker 5 set last becomes the active marker.)	
9	(SELECT No. has become marker 6.) 6 0 0 MHz OFF with AUTO SELECT F3	Sets marker 6 to 600 MHz. Turns off marker 6. (No.6 is set and SELECT No. is automatically shifted to No.7.)
10	Set markers 7 to 10 to 700 to 1000 MHz OFF markers respectively, the same as step 9.	

Step	Key operation	Description
11	[RETURN] [F6]	Returns to the MULTI MKR function keys menu.
	[MKR LIST ON/OFF] [F5]	Displays the marker list as MKR LIST ON.
12	[MANUAL SET] [F3]	Displays the MANUAL SET function keys menu and turns off the ON markers other than the active marker (marker 5). (Marker No.5 automatically changes to 1.)
	[CLEAR] [F5]	
13	[RETURN] [F6]	Returns to the MULTI MKR function keys menu.
	[MULTI MKR OFF] [F4]	Turns off the multi marker mode.
14	[RETURN] [F6]	Returns to the MARKER function keys menu.
	[RETURN] [F6]	Returns to the higher MARKER function keys menu.
	[RETURN] [F6]	Returns to page 1 of the SPECTRUM function keys menu.

Notes : Description of MANUAL SET function keys menu

- Each time the [SELECT No. : F1] key is pressed, the marker numbers to be turned on or off are scrolled and selected from 1 to 10.
- The [ON with AUTO SELECT : F2] key turns on the marker selected by [SELECT No. : F1] key and makes that marker an active marker. If the marker selected by [SELECT No. : F1] key is already on, the OFF marker of the next higher number is turned on. When the key is held down, the markers are turned on in ascending number order.
- The [OFF with AUTO SELECT : F3] key turns off the marker selected by [SELECT NO. : F1] key. If the marker selected by [SELECT No. : F1] key is already off, the ON marker of the next lower number is turned off. When the key is pressed sequentially, the markers are turned off in descending number order.
- Each time the [ACTIVE MARKER : F4] key is pressed, the ON markers \diamond are scrolled and selected in number order and are made active markers \blacklozenge .
- The [CLEAR : F5] key turns off all the markers other than the active marker. After that, the active marker number changes to 1.

4.4.11 FM modulation signal and external trigger signal waveform monitor (FM/TRIG MONITOR)

This paragraph describes the function that monitors the waveform of the FM modulation signal of a frequency modulated (FM) RF signal and the waveform of the external trigger signal input at the rear panel Trigger Input 1 (± 10 V) connector by time domain Lin scale. FM/TRIG MONITOR

- FM modulation signal waveform monitor FM MONITOR

The FM component of the RF signal is demodulated and displayed by an internal FM demodulator.

FM range	FM demodulation bandwidth
2 kHz/div (± 10 kHz full scale)	DC or AC 50 Hz to 50 kHz
20 kHz/div (± 100 kHz full scale)	DC or AC 50 Hz to 50 kHz
200 kHz/div (± 1 MHz full scale)	DC or AC 50 Hz to 1 MHz

[FM range : 2 kHz/div]

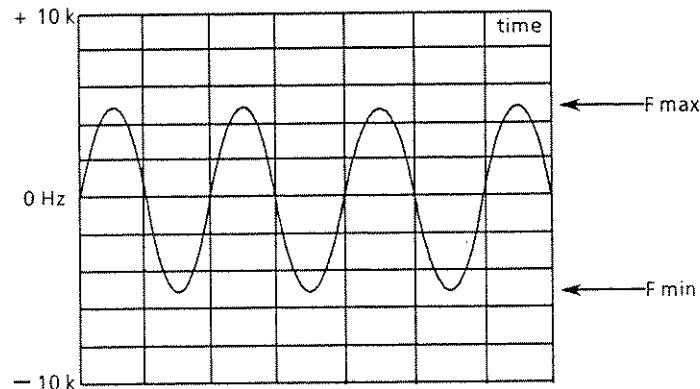

The FM peak shift ΔF is found from the waveform shown above using the equation below.

$$\Delta F = (F_{\max} - F_{\min})/2$$

F_{\max} and F_{\min} are easily found using marker position movement PEAK SEARCH (maximum level position)/MIN DIP (minimum level position). (See paragraph 4.4.10.)

Note : To reduce the demodulated waveform distortion, set RBW and VBW as follows:

Resolution bandwidth RBW > (FM shift + modulation frequency) \times 3

Video bandwidth VBW > modulation frequency \times 10 and as narrow as possible

● External trigger signal waveform monitor EXT TRIG MONITOR

The waveform of the external trigger signal input to the rear panel Trigger Input 1 (± 10 V) connector can be displayed as shown below by time domain Lin scale.

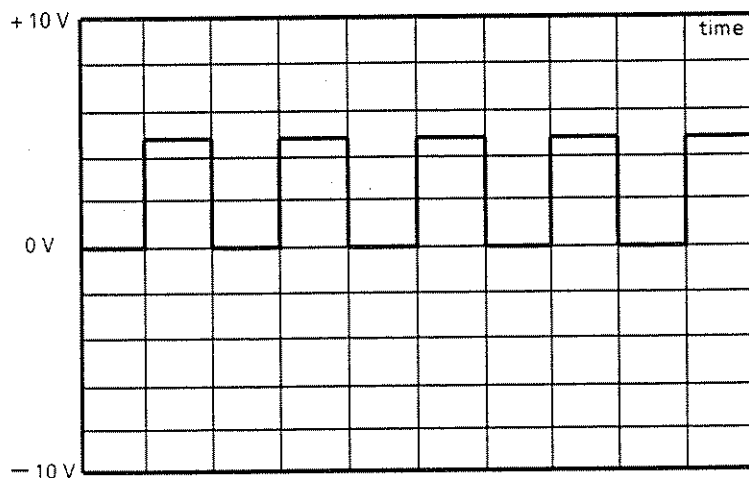

Note: The external trigger signal waveform monitor A/D-converts and displays the input signal directly.
The RBW and VBW settings are irrelevant.

(1) Ranges and initial values

FM/TRIG MONITOR:	FM MONITOR, EXT TRIG MONITOR, OFF	Initial value OFF
FM MONITOR:	200 kHz/div, 20 kHz/div, 2 kHz/div	Initial value 200 kHz/div
COUPLING (FM demodulator input coupling):	AC, DC	Initial value AC

(2) Setting

Setting is performed by function keys menu. (See Appendix A.)

Spectrum

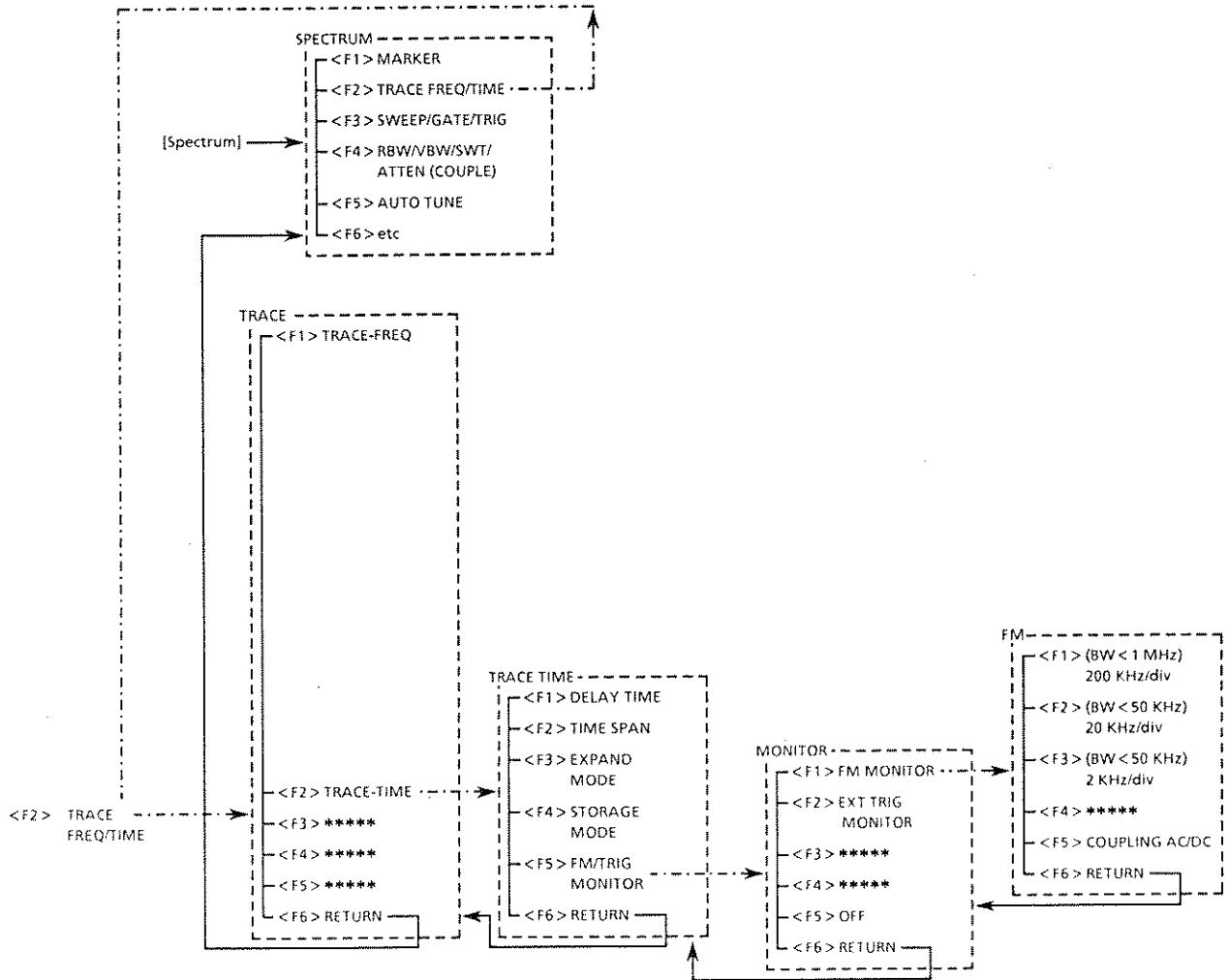

4.4.12 AM/FM demodulated signal sound monitor (SOUND)

This paragraph describes the function that monitors the sound of the AM/FM demodulated signal of an amplitude modulated (AM) or frequency modulated (FM) RF signal by time domain Lin scale using a built-in speaker. The center frequency is preset to the receiving frequency.

- AM demodulated signal sound monitor

Demodulates the AM component of the RF signal and drives the speaker by the built-in AM demodulator. The reference level (Lin scale) is preset to a suitable value corresponding to the RF level as shown below. RBW and VBW are set to 3 kHz or 10 kHz.

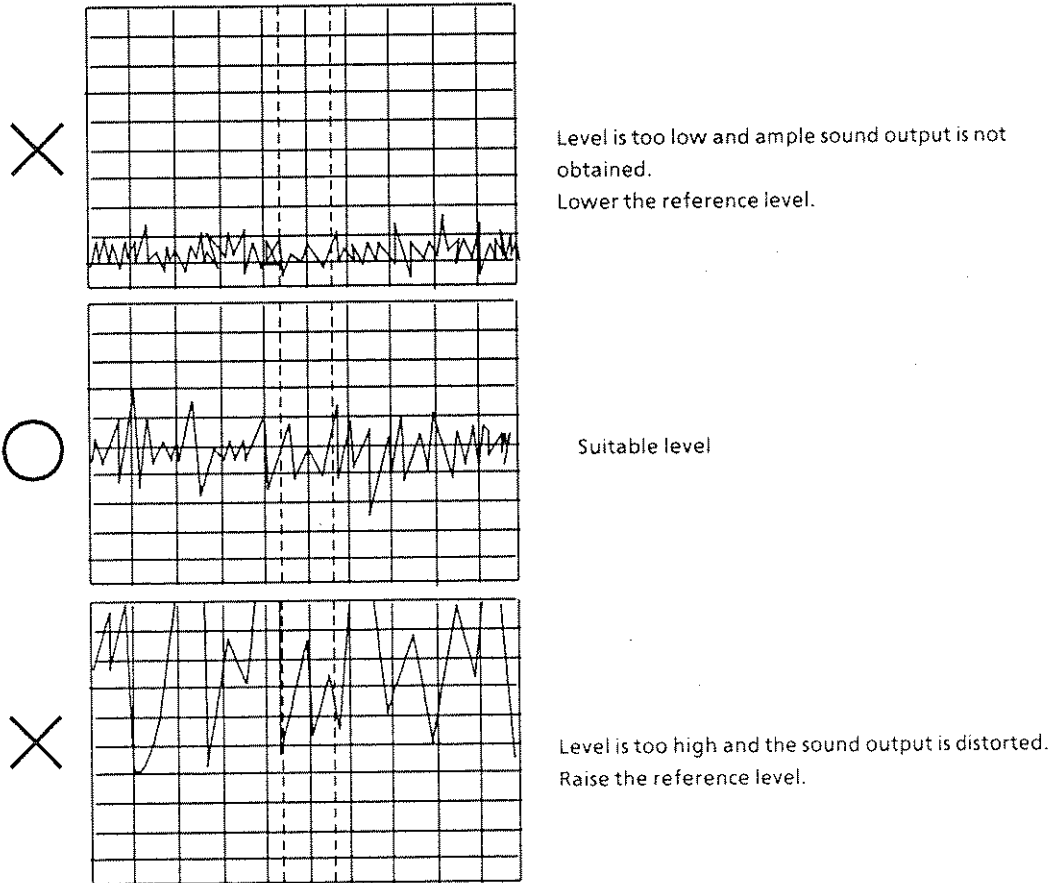

- FM demodulated signal sound monitor

Demodulates the FM component of the RF signal and drives the speaker by the built-in FM demodulator.

The level of the RF signal and reference level (Lin scale) are preset to about the same value. RBW is set as shown below.

Resolution bandwidth $RBW = (FM \text{ shift} + \text{modulation frequency}) \times \text{approx. } 3$

Examples :	FM mobile radio	RBW = 10 kHz
	FM broadcast, TV broadcast	RBW = 30 kHz

(1) Ranges and initial values

SOUND :	AM, FM, OFF	Initial value	OFF
VOLUME :	0 = 20 (step : 1)	Initial value	10

(2) Data input

VOLUME data can be input in any of the following ways:

- Setting by ten-key pad [0] to [9] and [ENTER] key.
- Setting by rotary knob
- Setting by Step/Select [↑] [↓] key

Other settings are performed by function keys menu. (See Appendix A.)

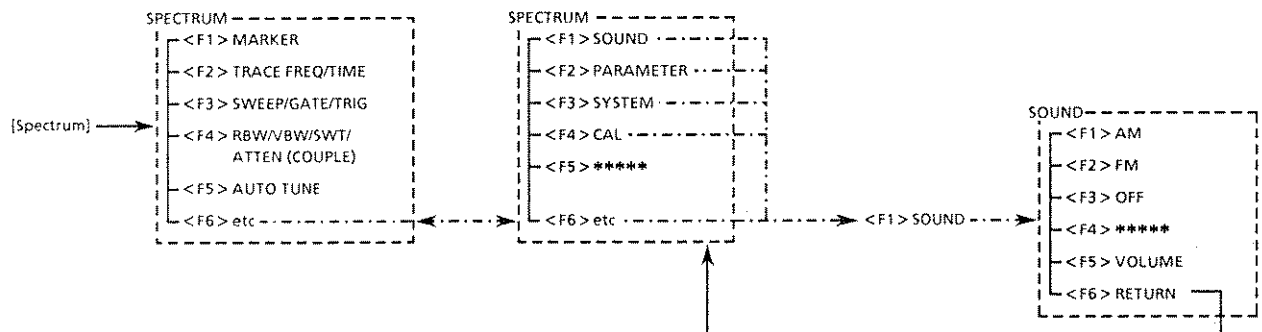
Spectrum

4.4.13 Parameters setting list display (PARAMETER)

This paragraph describes the SPECTRUM mode parameter list display function.

[LIST PAGE 1]

```

PARAMETER LIST<1>

< TRACE-FREQ >
CENTER FREQ : 4.250 000 000GHz
FREQ SPAN : 8.500 000 000GHz
START FREQ : 0Hz
STOP FREQ : 8.500 000 000GHz
RES BW : 1MHz
VIDEO BW : 1MHz
SWP TIME : 200ms
SCALE : LOG,10dB/
TR STORAGE: NORMAL
TR DET : POS PEAK

< TRACE-TIME >
FREQUENCY : 4.250 000 000GHz
TIME SPAN : 200ms
DELAY TIME : 0ms
EXPAND : OFF
RES BW : 1MHz
VIDEO BW : 1MHz
SCALE : LOG,10dB/

< COMMON PARAMETERS >
FREQ BAND : BAND AUTO
REF LEVEL : 10.0dBm
RF ATTEN : 25dB
LOG UNIT : dBm
    
```

[LIST PAGE 2]

```

PARAMETER LIST<2>

< TRACE >
DISPLAY : TRACE-FREQ
FM/TRIG MON : OFF

< SWEEP CONTROL >
TRIGGER : FREE RUN
SWEEP MODE : CONTINUOUS
ZONE SWEEP : OFF
SIGNAL TRNG : OFF
GATE SWEEP : OFF

< PARKER >
MODE : NORMAL
MULTI TRK : OFF

< OTHERS >
SOUND : OFF

< HARD COPY >
DEVICE : PRINTER
PRINTER : 2225.#17

< MEMORY MEDIA >
MEDIA : INT PIC

< INTERFACE >
PORT-1 : GP-1B.#1
DEVICE
PORT-2 : GP-1B.#16
CONTROLLER

< SYSTEM >
AUTO SMT : NORMAL
DATA POINTS: 501
COUPLE MODE: COMMON
    
```

(1) Ranges and initial values

PARAMETER: LIST PAGE 1, LIST PAGE 2, OFF Initial value OFF

(2) Setting

Setting is performed by function keys menu. (See Appendix A.)

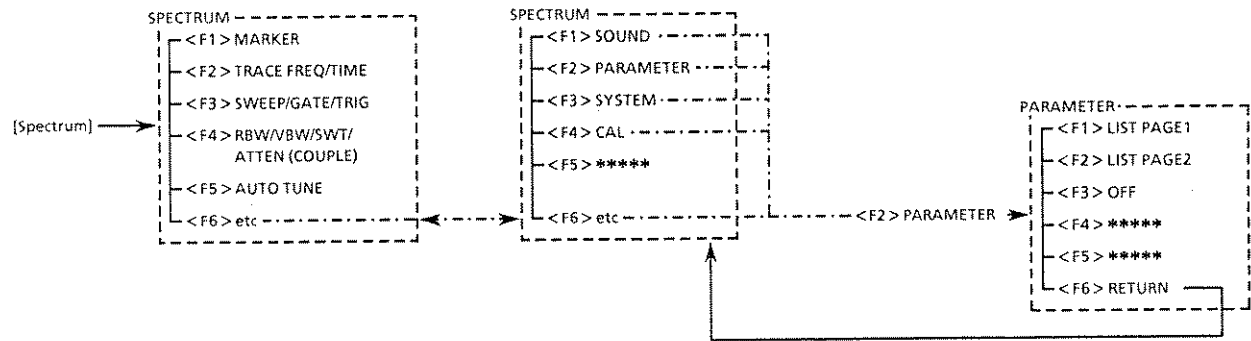
Spectrum

4.4.14 System setting (SYSTEM)

This paragraph describes the SPECTRUM mode system parameters AUTO SWT (FAST/SLOW), DATA POINTS (NORMAL/DOUBLE), and RBW/VBW/SWT MODE (COMMON/INDEPENDENT). These parameters are not affected by initialization. They are included in the save parameters.

- AUTO SWT (FAST/SLOW)

Sets the value of K of the sweep time setting condition expressions in the AUTO sweep mode. (See paragraph 4.4.9 (2).)

RBW ≤ VBW	Swp Time = K × SPAN / (RBW) ²	
RBW > VBW	Swp Time = K × SPAN / (RBW × VBW)	
K = 3	AUTO SWT: SLOW	Set when accurate measurement is required. Conforms to the MS8604A specifications.
K = 2	AUTO SWT: FAST	Sweeps comparatively quickly. Set when accurate measurement is not required.

- DATA POINTS (NORMAL/DOUBLE)

Sets number of data points NORMAL 501/DOUBLE 1002. Number of data points 501/1002 are the number of internal measurement points. In both cases, the number of points displayed on the screen is 501.

- RBW/VBW/SWT MODE (COMMON/INDEPENDENT)

Sets whether RBW, VBW, and SWT are made common COMMON or independent INDEPENDENT in frequency domain and time domain modes. (See paragraph 4.4.9.) In time domain mode, when RBW and VBW are set independently, "RBt" and "VBt" are displayed on the screen.

Note: The ATTEN value cannot be set independently.

(1) Ranges and factory settings

AUTO SWT:	SLOW, FAST	Factory setting	SLOW
DATA POINTS:	NORMAL, DOUBLE	Factory setting	NORMAL
RBW/VBW/SWT MODE:	COMMON, INDEPENDENT	Factory setting	COMMON

(2) Setting

Setting is performed by function keys menu. (See Appendix A.)

Spectrum

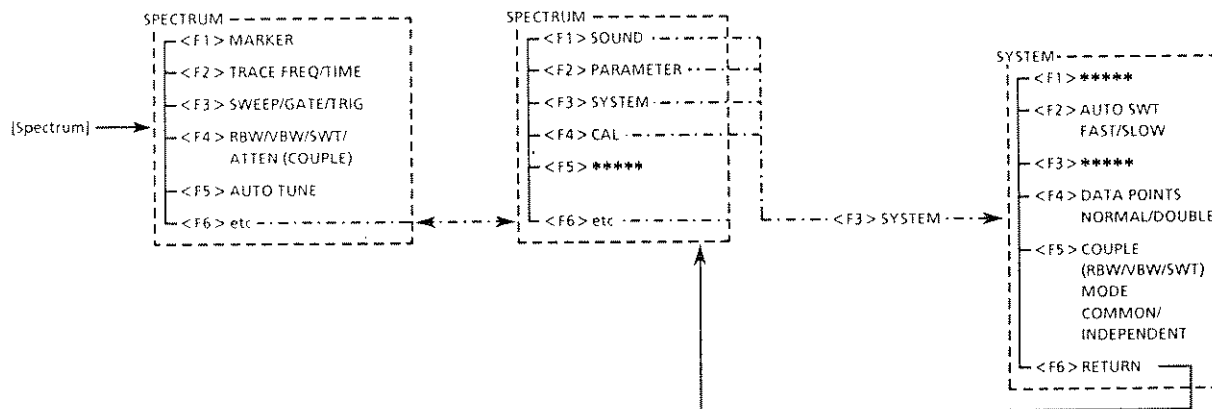

4.4.15 Calibration (CAL)

This paragraph describes automatic calibration and preselector tuning in SPECTRUM mode. The preselector tuning peaking bias value is not affected by initialization.

- Calibration

Calibrates the level and frequency errors.

Level error calibration contents : Reference level error, Log scale linearity error, IF amplifier gain, RBW, and detection mode switching error

Frequency error calibration contents : IF center frequency error at RBW switching, FM demodulator detector linearity error, RBW bandwidth error

The calibration data is backed up and is preserved even when the power is turned off.

Do not apply the measured signal during calibration.

A clock that shows the elapse of time is displayed during calibration.

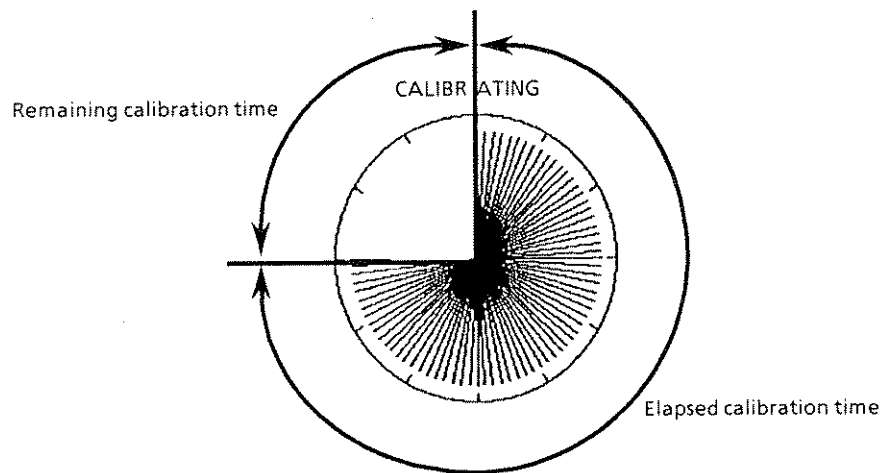

- Preselector tuning

The preselector is a band pass filter for rejecting unwanted spectrum analyzer signals (image response, multiple response). Its center frequency tracks the input signal frequency.

The preselector is used at frequency bands 1 – (1.7 to 7.5 GHz) and 1 + (6.5 to 8.5 GHz).

During normal use, tuning (peaking) is unnecessary. When the tuning peaking bias has drifted, retune the preselector so that the maximum response is obtained as shown below.

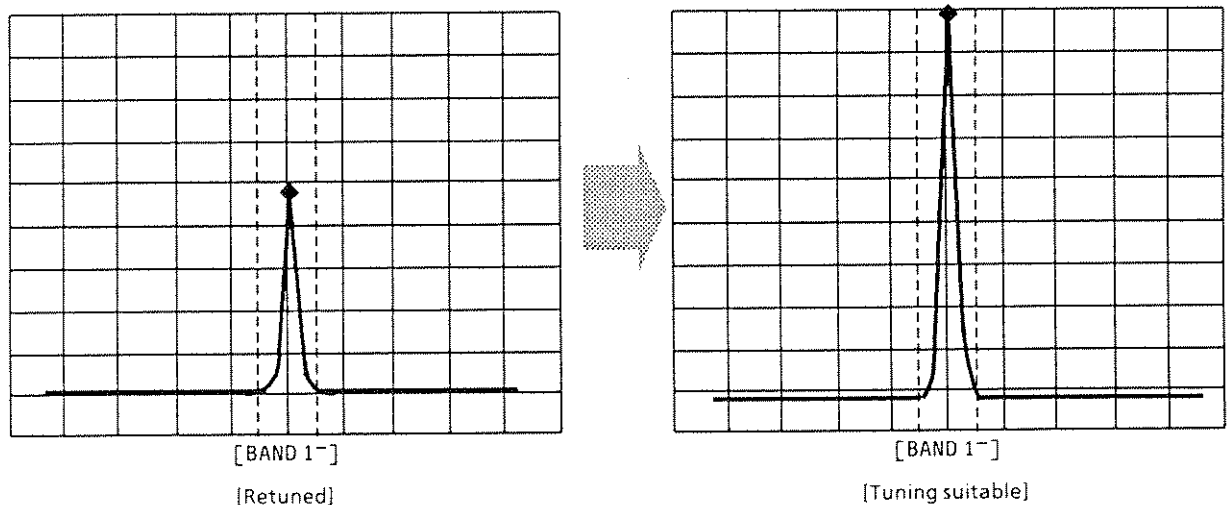

Note : Preselector AUTO TUNE is inoperative in the following cases:

- Frequency span > 500 MHz
- Marker OFF
- Time domain FM/TRIG MONITOR mode

(1) Ranges and factory settings

CAL : ALL, LEVEL, FREQ
 PRESEL TUNE : AUTO TUNE, ENTRY MANUAL TUNE, PRESET (bias 0)
 ENTRY MANUAL TUNE : -128 to 127 (step : 1) Factory setting 0

(2) Setting

The preselector tuning peaking bias value is set in any of the following ways:

- Setting by ten-key pad [+ / -] [0] to [9] and [Enter] keys
- Setting by rotary knob
- Setting by Step/Select [↑] [↓] key

Other settings are performed by function keys menu. (See Appendix A.)

Spectrum

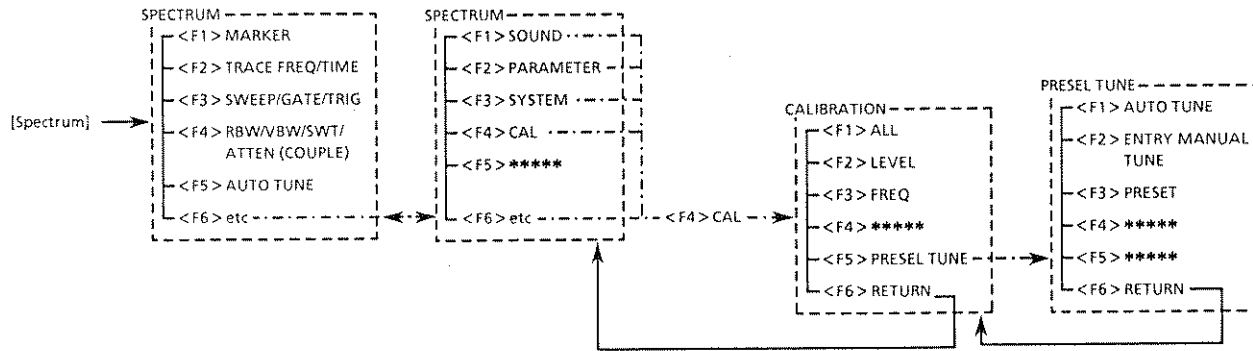

4.5 System Setting (SYSTEM SETUP)

4.5.1 Overview of setting

System setting begins with setting the MS8604A to the SYSTEM mode by pressing the front panel [System] key.

The following items are set by function key, as required.

- Data file
Title (TITLE), date (DATE), time (TIME), directory display (DIR), file deletion (DELETE FILE No.), media initialization (FORMAT), media (internal memory PMC, external MC8104A storage unit PMC1, PMC2/FD) selection (SELECT MEDIA), write protect (WRITE PROTECTION)
- Alarm tone on/off (ALARM)
- GPIB address (GPIB1, GPIB2, MC8104A) (ADDRESS) (For a description of printer address setting, see paragraph 4.7.)
- RS-232C (Option)

4.5.2 Data file setting

- The data file name is shown below.

TX Test mode: PRMTR *** DAT Comment Number of bytes Date Time Write protect

Spectrum mode:

TRACE *** DAT Comment Number of bytes Date Time Write protect

↑ ↑ ↑ ↑ ↑ ↑ ↑ ↑

File name attribute byte (s) Time

File No. Comment Date Write protection (ON/OFF)

Item	TX Test mode	Spectrum mode
*** (file No.)	101 to 199	001 to 099
File contents	Setup parameters only	Waveform data and setup parameters
Comment	System standard name (PDC, etc.) or first 25 characters (both modes) of user-defined USER DEFINE title	SPECT
Date	(1990) 90-01-01 to (2089) 89-12-31 (both modes)	
Time	00:00:00 to 23:59:59 (both modes)	

SECTION 4 OPERATION

- The following can be selected as the PMC or FD for saving data files.

INT PMC : MS8604A built-in PMC

EXT PMC1 : PMC1 of MC8104A Data Storage Unit connected externally by GPIB

EXT PMC2 : PMC2 of MC8104A Data Storage Unit connected externally by GPIB

EXT FD : FD of MC8104A Data Storage Unit connected externally by GPIB

Note : PMC (Plug-In Memory Card)

38 pins (Fujisoku)

SRAM type 32 to 512 k bytes (2ⁿ step)

FD

IBM : 1.44 M bytes, 720 k bytes

PC-9801: 640 k bytes

- When files are saved to PMC or FD, they are automatically separated by mode and stored to the subdirectory MS8604 under the root directory.

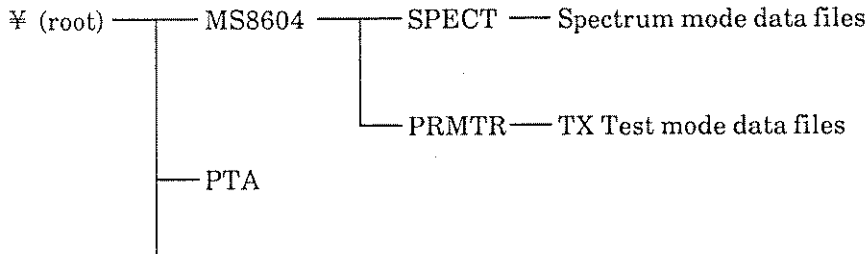

- Directory display DIR displays all the TX Test mode and Spectrum mode files in the directory of the selected PMC or FD.
- When a PMC or FD is formatted, subdirectory MS8604 is automatically created under the root directory.

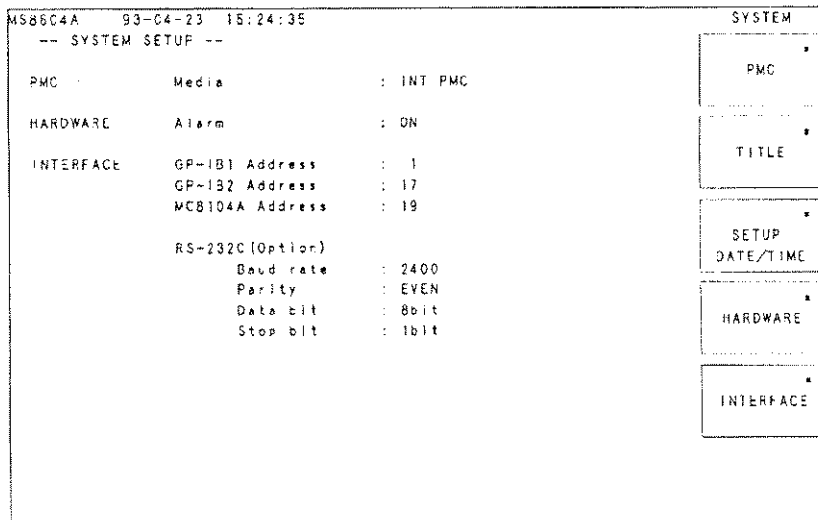

RS-232C and the items following it are displayed only when the option is installed.

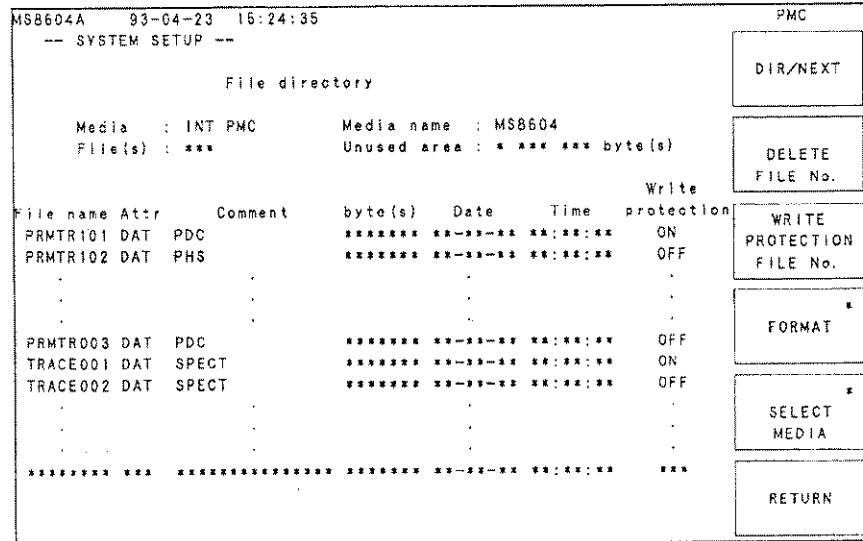

- Setting is mainly performed by function keys menu. (See Appendix A.) For a description of title, date, and time setting, see items (2) and (3).

System screen

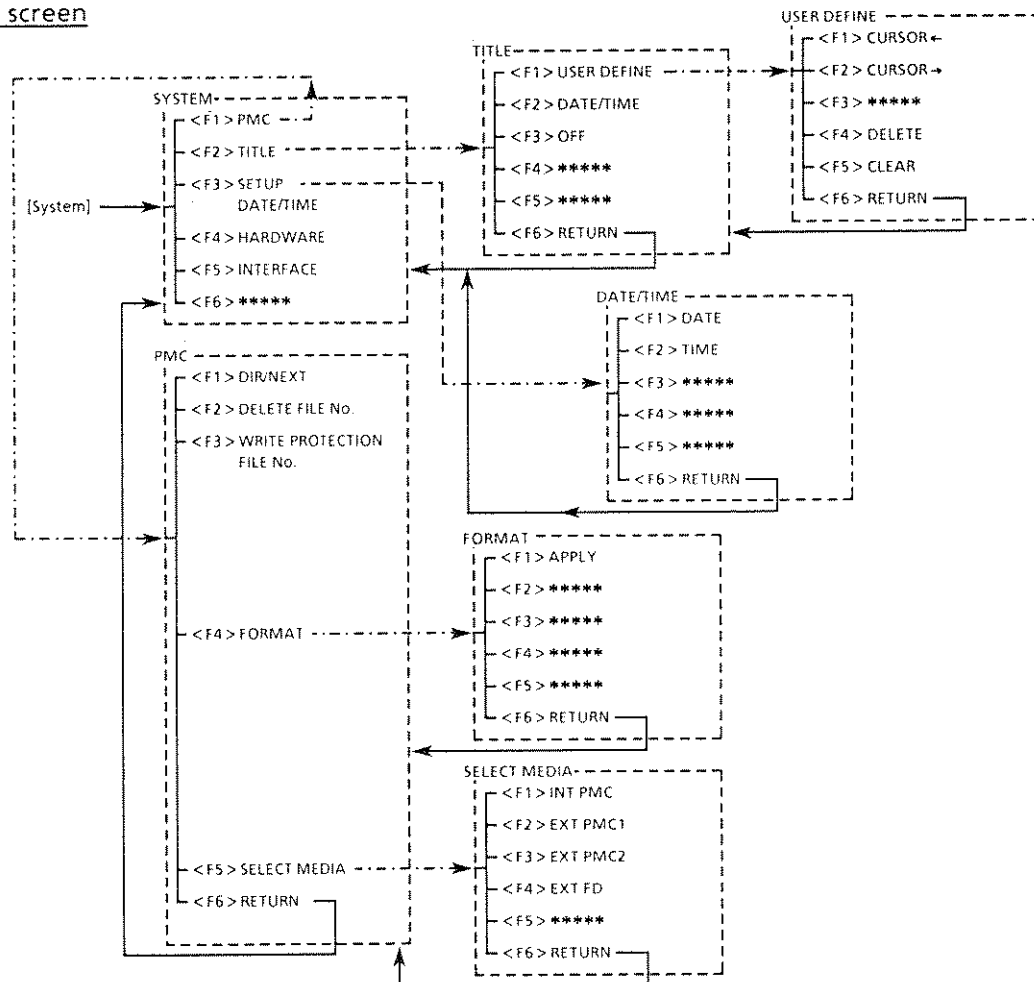











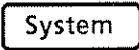
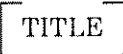





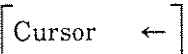

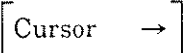

(1) Ranges and initial values

TITLE : USER DEFINE, DATE/TIME, OFF Initial value DATE/TIME
 SELECT MEDIA : INT PMC, EXT PMC1, EXT PMC2, EXT FD Initial value INT PMC

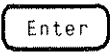
(2) Title setting

A title of up to 32 characters long can be input in the title display area (top left line). (USER DEFINE) MS8604A **-**-** (date) **: **: ** (time) is displayed as the initial value. (DATE/TIME)
 For a description of date and time setting, see item (3).

Example : Set the title "Anritsu".

Step	Key operation	Description
1		Selects the system screen.
2	 	Displays the TITLE function keys menu.
3	 	Displays the USER DEFINE function keys menu. The previously set title is displayed in the title display area.
4	 	Clears the previous title.
5	   	Sets the title display area character entry position.
6	Cursor key or rotary knob	Selects the title characters from the candidate title characters list.
	Ten-key pad   to  	Selects 0 to 9..
		Inputs the selected character in the title display area.
7	 	When the selected character is incorrect, deletes it.
8	Input "Anritsu" in the title display area by repeating steps 5, 6, and 7.	
9	   	Returns to the TITLE function keys menu. Returns to the SYSTEM function keys menu.

Notes : • The panel [BS] key deletes the character in front of the cursor and fills up the rear of the title display area.

• Input can be performed easily using the PTA keyboard.

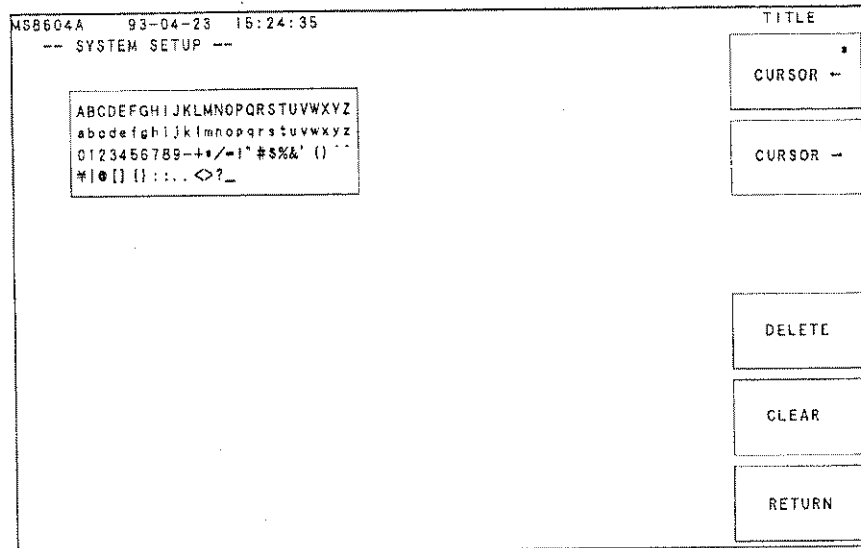

(3) Date and time setting

The title display area (top left line) date and time can be set.

Example: Set 3:15:3 P.M. on May 3, 1993.

Step	Key operation	Description
1	<input type="button" value="System"/>	Selects the system screen.
2	<input type="button" value="SETUP DATE/TIME"/> <input type="button" value="F3"/>	Displays the DATE/TIME function keys menu.
3	<input type="button" value="DATE"/> <input type="button" value="F1"/>	The current date is displayed at the communication area (bottom line).
4	<input type="button" value="9"/> <input type="button" value="3"/> <input type="button" value="0"/> <input type="button" value="5"/> <input type="button" value="0"/> <input type="button" value="3"/> <input type="button" value="Enter"/>	Resets the date to May 3, 1993.
	<input type="button" value="TIME"/> <input type="button" value="F2"/>	The current time is displayed at the communication area (bottom line).
	<input type="button" value="1"/> <input type="button" value="5"/> <input type="button" value="1"/> <input type="button" value="5"/> <input type="button" value="0"/> <input type="button" value="3"/> <input type="button" value="Enter"/>	Resets the time to 3:15:3 P.M.
5	<input type="button" value="RETURN"/> <input type="button" value="F6"/>	Returns to the SYSTEM function keys menu.

Note: The date and time can be set from the ten-key pad only.

4.5.3 Alarm tone setting

(1) Range and initial value

ALARM: ON, OFF Initial value ON

4.5.4 RF input connector setting

(1) Range and initial value

RF INPUT: HIGH, LOW Initial value HIGH

- Setting is performed by function keys menu. (See Appendix A.)

System screen

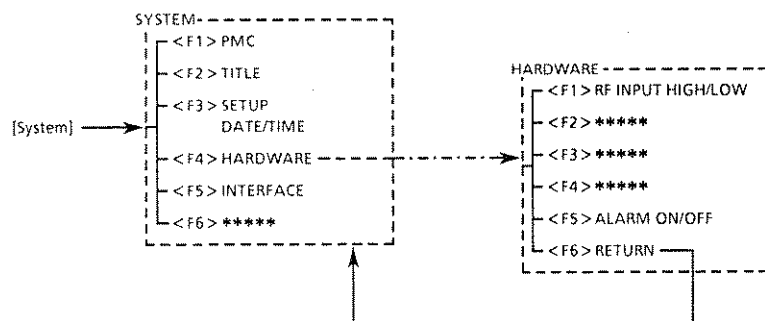

4.5.5 GPIB address setting

(1) Ranges and initial values

GPIB1 ADDRESS:	0 to 30 (step : 1)	Initial value	1
GPIB2 ADDRESS:	0 to 30 (step : 1)	Initial value	16
MC8104A ADDRESS:	0 to 30 (step : 1)	Initial value	19

Note : For a description of printer GPIB address setting, see paragraph 4.7.

- Setting is performed by function keys menu. (See Appendix A.)

System screen

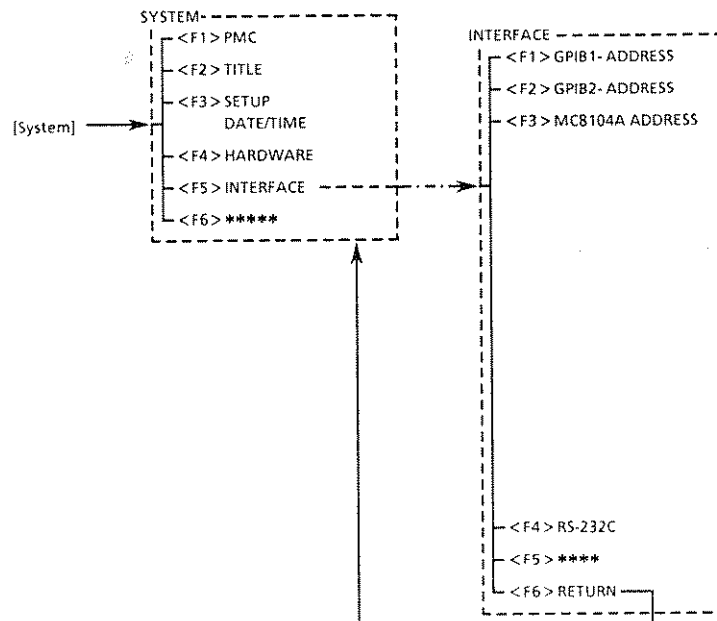

4.5.6 RS-232C setting (Option)

(1) Ranges and initial values

BAUD RATE :	9600, 4800, 2400, 1200, 600, 300	Initial value	2400
PARITY :	EVEN, ODD, OFF	Initial value	EVEN
DATA BIT :	7 bits, 8 bits	Initial value	8 bits
STOP BIT :	1 bit, 1.5 bits, 2 bits	Initial value	1 bit

- Setting is performed by function keys menu. (See Appendix A.)

System screen

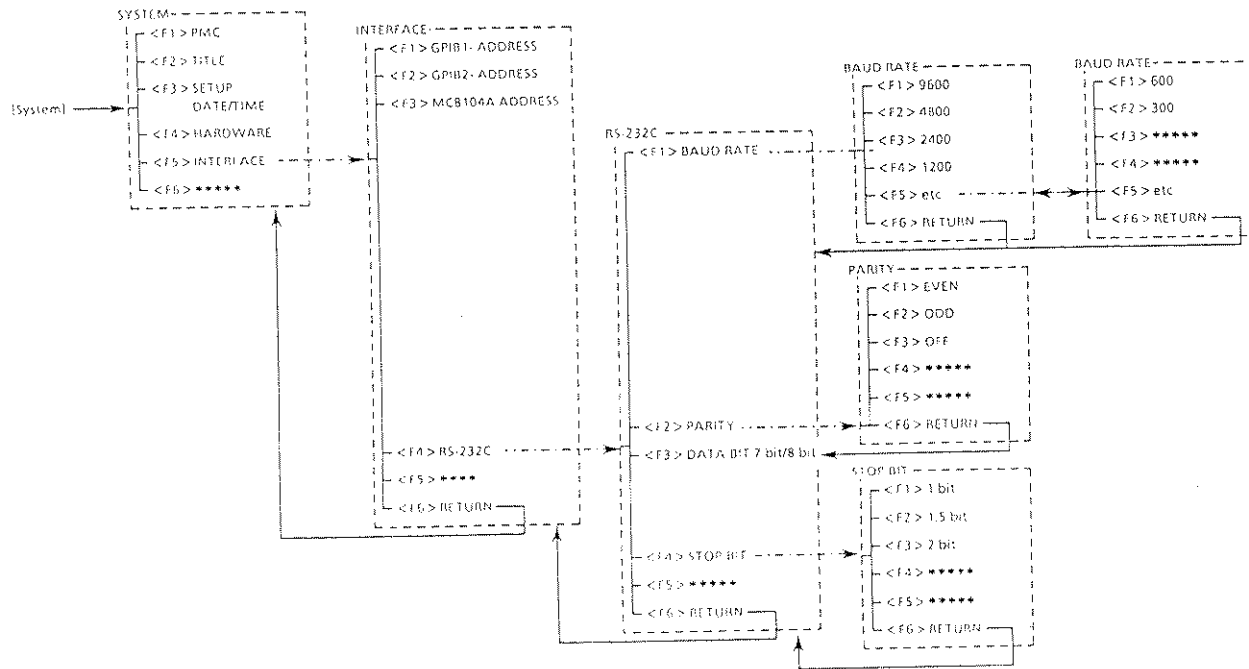

4.6 Save/Recall

This paragraph describes operation when saving and recalling data files (setting parameters in TX Test mode and setting parameters/waveform data in SPECTRUM mode; see paragraph 4.5.2) in the internal memory and PMC, or external MC8104A Data Storage Unit PMC and FD.

- The following can be selected as the media for saving and recalling the current setting data:

MEMORY : MS8604A built-in memory
(Four each in TX Test mode and SPECTRUM mode.)

INT PMC : MS8604A built-in PMC

EXT PMC1 : PMC1 of MC8104A Data Storage Unit connected externally by GPIB.

EXT PMC2 : PMC2 of MC8104A Data Storage Unit connected externally by GPIB.

EXT FD : FM of MC8104A Data Storage Unit connected externally by GPIB.

- Recall is executed by pressing the [Recall] key.
- Save is executed by pressing the [Shift] [Recall] keys.
- Save and recall setting is performed by function keys menu. (See Appendix A.)

Save

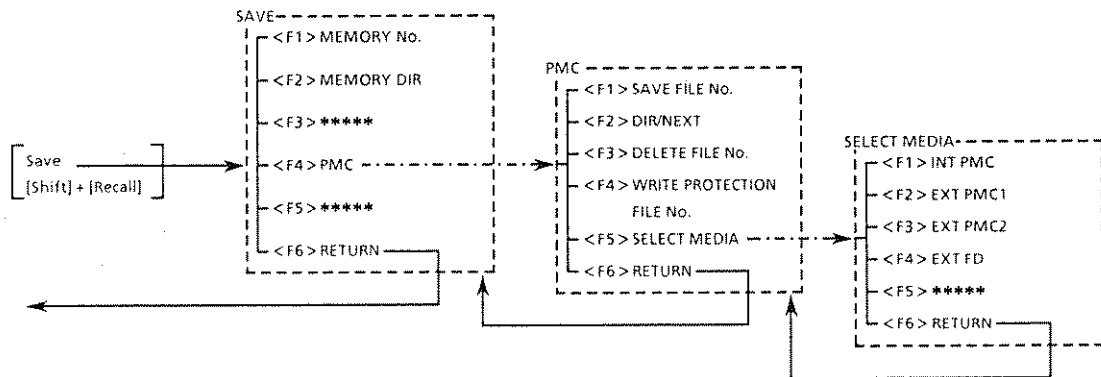

Recall

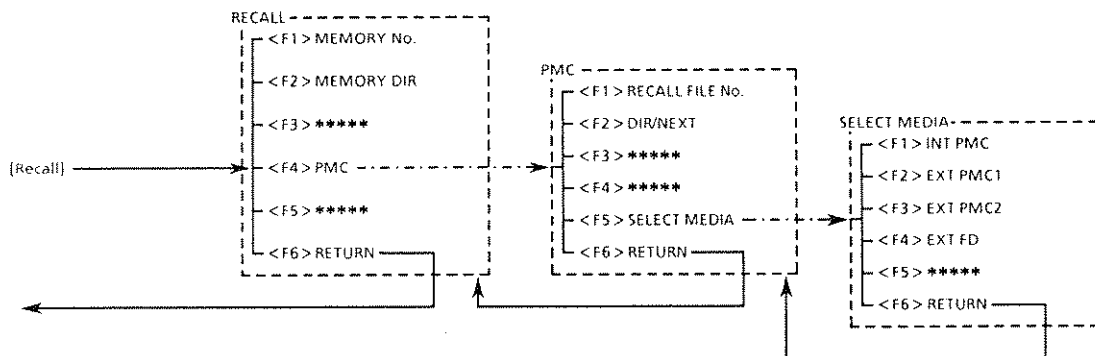

4.7 Copy

This paragraph describes operation when copying the screen display at a printer (HP HP2225/corresponding to ESC/P/Anritsu UA455A/MC8104A). See paragraph 4.5.2.

- Printer GPIB address : 0 to 30 (step : 1)
Initial value 17
- Hard copy is executed by pressing the [Copy] key.
- Copy setting begins from pressing of the [Shift] [Copy] keys and is mainly performed by function keys menu.
(For the function keys menus, see Appendix A and for the UA-445A connection method, see Appendix D.)
- When outputting to the printer corresponding to ESC/P, set to 24 DOT. However, if the 24-dot graphic output is impossible, set to 8 DOT. (Refer to each printer Operation Manual for details.)

Copy control

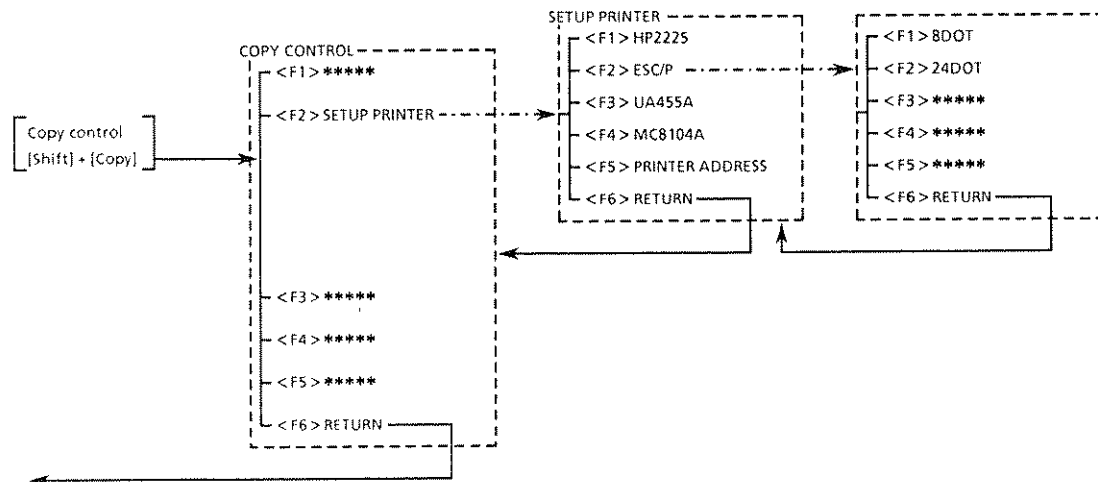

4.8 Initialization

This paragraph describes the operation for returning the set values to their initial value.

Initialization is performed by pressing the front panel [Preset] key.
The data saved in internal memory does not change.

To clear the data in internal memory, turn the power on while pressing the [Preset] key.

The initial value table is shown in Appendix B.

4.9 GPIB Remote Reset

The GPIB remote mode is reset and the MS8604A is returned to local mode by pressing the front panel [Local] key.

4.10 PTA Setting

Turn on the PTA function by pressing the front panel [PTA] key.

In the ON state, the key lamp lights and only [0] [1] to [9] [.] [,] [+/−] [BS], [Enter], and [Local] front panel key input is effective.

For a description of operation, refer to the separate PTA manual.

4.11 I/Q Input (Option)

Modulation, amplitude, and occupied frequency bandwidth measurements can be made by applying an I/Q signal (0.3 to 1.5 V peak) to the front panel I/Q INPUT connector by I/Q input (Option 03).

When the I/Q signal has a DC component, INPUT Terminal of the SETUP PARAMETER screen is made AC coupling (IQ – AC). When the I/Q signal does not have a DC component, INPUT Terminal is made DC coupling (IQ – DC).

For a description of the measurement operation, see paragraph 4.3.

SECTION 5 PERFORMANCE TESTS

This section lists the equipment required for performing the performance tests, and explains each setup and the performance test items.

TABLE OF CONTENTS

5.1	Requirement for Performance Tests	5-3
5.2	Instruments Required for Performance Test	5-4
5.3	Performance Test	5-6
5.3.1	Reference oscillator frequency stability	5-6
5.3.2	Center frequency readout accuracy	5-8
5.3.3	Frequency span readout accuracy	5-10
5.3.4	Amplitude scale linearity	5-13
5.3.5	Frequency characteristics	5-16
5.3.6	Reference level accuracy	5-19
5.3.7	Instrument accuracy and zero shift between ranges	5-21
5.3.8	Calibration oscillator output accuracy	5-24
5.3.9	PDC frequency/modulation accuracy	5-26
5.3.10	PDC transmission power accuracy	5-28
5.3.11	PHS frequency/modulation accuracy	5-30
5.3.12	PHS transmission power accuracy	5-32
5.3.13	NADC frequency/modulation accuracy	5-34
5.3.14	NADC transmission power accuracy	5-36

(Blank)

SECTION 5

PERFORMANCE TESTS

5.1 Requirement for Performance Tests

The performance test is carried out as a part of preventive maintenance in order to prevent deterioration of the MS8604A.

Use the performance test procedures at acceptance inspection, periodic inspection and after repair of the MS8604A. Conduct the important preventive maintenance items periodically. This section explains the following performance test procedures:

- Reference oscillator frequency stability
- Center frequency readout accuracy
- Frequency span readout accuracy
- Amplitude display linearity
- Frequency characteristics
- Reference level accuracy
- Instrument accuracy and zero shift between ranges
- Calibration oscillator output accuracy
- PDC frequency/modulation accuracy
- PDC transmission power accuracy
- PHS frequency/modulation accuracy
- PHS transmission power accuracy
- NADC frequency/modulation accuracy
- NADC transmission power accuracy

Execute the performance tests at regular intervals as preventive maintenance for important evaluation items.

We recommend that the performance be inspected regularly once or twice a year.

If the specifications are not met at the performance tests, please contact Service Department of Anritsu Corporation.

5.2 Instruments Required for Performance Test

A list of instruments required for performance test is shown below.

Instruments Required for Performance Test (1/2)

Recommended instrument name (Model name)	Required Performance †	Test item
Synthesized signal generator (MG3633A)	<ul style="list-style-type: none"> • Frequency range 100 MHz to 1 GHz Resolution of 1 Hz possible • Output level range – 20 to +10 dBm Resolution of 0.1 dB possible • SSB phase noise ≤ -130 dBc / Hz (at 10 kHz offset) • Second harmonic ≤ -30 dBc • External reference input (10 MHz) possible 	Frequency-span display accuracy Amplitude display linearity Reference-level accuracy Frequency/modulation accuracy Transmission power accuracy
Swept Frequency Synthesizer (WILTRON 6769B with Option 2C)	<ul style="list-style-type: none"> • Frequency range 10 MHz to 8.5 GHz Resolution of 2 kHz possible • Output level range – 20 to 0 dBm Resolution of 0.1 dB possible • External reference input (10 MHz) possible 	Center-frequency display accuracy Frequency-span display accuracy Frequency characteristics
Attenuator (MN510C)	<ul style="list-style-type: none"> • Frequency 100 MHz • Maximum attenuation 80 dB (resolution 0.1 dB) possible with calibrated data 	Amplitude display linearity
Power meter (ML4803A)	<ul style="list-style-type: none"> • Main instrument accuracy ± 0.02 dB • Frequency range 100 kHz to 8.5 GHz (depending on the power sensor type) 	Frequency characteristics Reference-level accuracy

† Extracts part of performance which can cover the measurement range of the test item.

Instruments Required for Performance Test (2/2)

Recommended instrument name (Model name)	Required performance †	Test item
Power Sensor (MA4701A)	<ul style="list-style-type: none"> • Frequency range 2 to 8.5 GHz • Measurement power range – 30 to + 20 dBm • Input connector N type 	Frequency characteristics
Power sensor (MA4601A)	<ul style="list-style-type: none"> • Frequency range 10 MHz to 2 GHz • Measurement power range – 30 to + 20 dBm • Input connector N type 	Frequency characteristics Reference-level accuracy
50 Ω terminator (MP752A)	<ul style="list-style-type: none"> • Frequency range DC to 8.5 GHz • VSWR ≤ 1.2 	Frequency/modulation accuracy
Frequency counter (MF1601A)	<p>10 MHz measurement possible Number of display digits: 10</p> <ul style="list-style-type: none"> • External reference input (10 MHz) possible 	Reference-oscillator frequency stability
Frequency standard	<ul style="list-style-type: none"> • Frequency 10 MHz • Stability ≤ 1 × 10⁻⁹/day 	Reference-oscillator frequency stability
Range calibrator (MA4001A)	<ul style="list-style-type: none"> • Output accuracy: ± 0.2 % at equivalent to full scale 0 dBm 	Instrument accuracy Zero shift between ranges
Standard output signal source (HP 435A-K06)	<ul style="list-style-type: none"> • Output accuracy: 1 mW ± 1.2 % • Frequency: 50 MHz 	Calibration oscillator output accuracy
4-port combining pad (MA1612A)	<ul style="list-style-type: none"> • Frequency range: 10 MHz to 2 GHz 	Frequency/modulation accuracy

† Extracts part of performance which can cover the measurement range of the test item.

5.3 Performance Test

The warm-up time depends on the test item. For test item other than oscillator frequency, warm-up the equipment for at least for thirty minutes and test the performance after the MS8604A stabilizes completely. Also, begin measurement after taking the warm-up time of the calibration instrument into full consideration. In addition, the test must be conducted at room temperature; there must be little AC power supply voltage fluctuation, and no noise, vibration, dust, humidity, etc.

5.3.1 Reference oscillator frequency stability

The frequency stability of the 10 MHz crystal oscillator used as the reference oscillator is tested. Measure the frequency change after 24 hours and 48 hours after power-on (aging rate) at ambient temperatures of both 0 and 50 °C (temperature characteristic).

(1) Specifications

■ Reference oscillator

- Frequency: 10 MHz
- Aging rate: $\leq \pm 2 \times 10^{-8}$ / day
After 24 hour warm-up at 25 °C \pm 5 °C
(Option 01 $\leq \pm 5 \times 10^{-9}$ / day, After 24-hour operation, 25 °C \pm 5 °C)
- Temperature stability: $\leq \pm 5 \times 10^{-8}$ at 0 and 50°C referred to frequency at 25°C
(Option 01 $\leq \pm 3 \times 10^{-8}$, 0 to 50 °C (25 °C reference))

(2) Test instruments

- frequency counter: MF1601A
- Frequency standard: with stability of $\leq \pm 1 \times 10^{-9}$ /day

(3) Setup

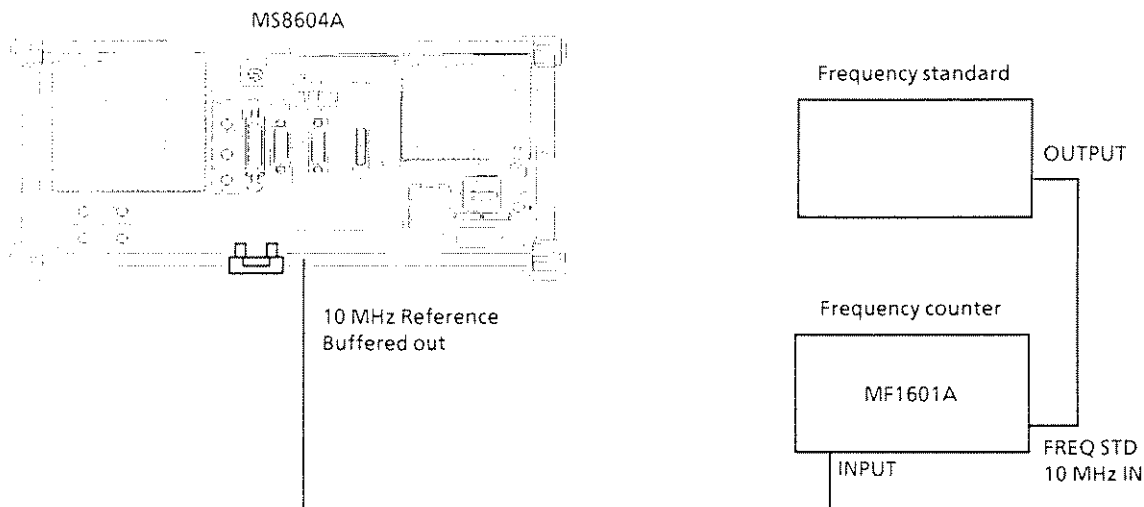

Reference Oscillator Frequency Stability Test

(4) Procedure

Aging rate/day: Test this at the ambient temperature $\pm 2^\circ\text{C}$ in a vibration-free place.

Step	Procedure
1	Set the changeover switch (FREQ STD: INT/EXT) on the MF1601A counter rear panel to EXT.
2	Set the power supply switch on the MS8604A rear panel to On and then the Power switch on the MS8604A front panel to On.
3	Measure the frequency using the counter with 0.1 Hz resolution after 24 hours have passed after turning the power ON.
4	Measure the frequency using the counter after 24 more hours have passed from the step 3 measurement.
5	Calculate the stability by using the following equation.
$\text{Frequency stability} = \frac{(\text{counter reading in step 4}) - (\text{counter reading in step 3})}{(\text{counter reading in step 3})}$	

Temperature stability: Test this performance in a vibration-free constant-temperature chamber.

Step	Procedure
1	Set up the MS8604A in a constant-temperature chamber at 25°C in the same setup.
2	Set the LINE and Power switches on the MS8604A to On and wait until the MS8604A internal temperature stabilizes (approx. 1.5 hours after the chamber temperature stabilizes).
3	When the internal temperature stabilizes, measure the frequency by using the counter with 0.1 Hz resolution.
4	Change the chamber temperature to 50°C .
5	When the chamber temperature and the MS8604A internal temperature re-stabilize, measure the frequency by using the counter.
6	Calculate the stability by using the following equation.
$\text{Frequency stability} = \frac{(\text{counter reading in step 5}) - (\text{counter reading in step 3})}{(\text{counter reading in step 3})}$	
7	Change the chamber temperature to 0°C and repeat steps 5 and 6.

5.3.2 Center frequency readout accuracy

Add the known frequency which serves as the center frequency reference to the MS8604A as shown in the figure below and set CF (same value as the known reference frequency) and SPAN. At this time, check that the difference between the reading of the marker readout frequency (thick arrow in the figure) of the center frequency peak point, and the CF set value is $\leq \pm$ (frequency span \times span accuracy).

As shown in the figure, the Synthesized Signal Generator uses the signal source phase-locked with the same accuracy as the 10 MHz reference oscillator of the MS8604A.

(1) Specifications

- Center frequency accuracy: \pm (Indicated frequency \times reference frequency accuracy + span \times span accuracy)

(2) Test instruments

- Synthesized signal generator: Wiltron 6769B

(3) Setup

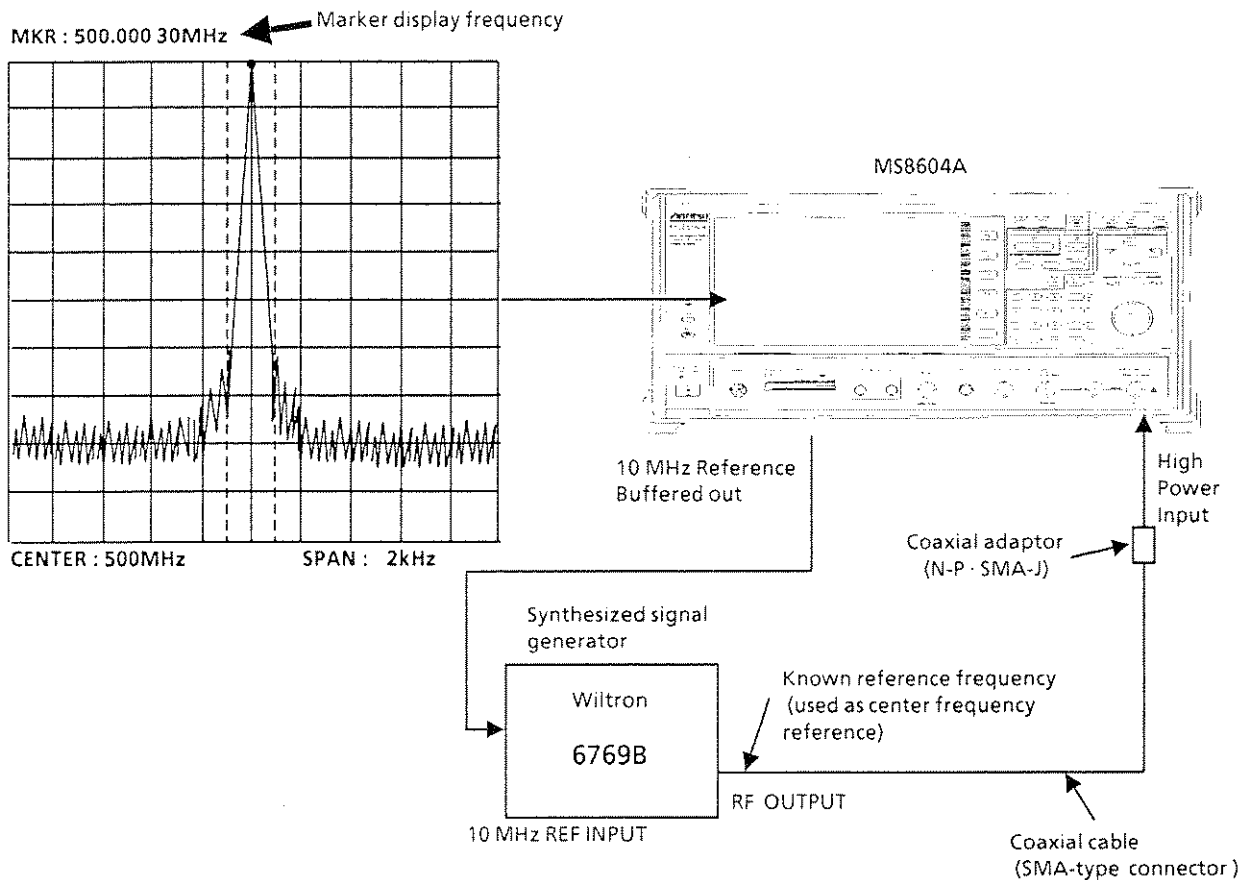

Center-Frequency Readout-Accuracy Test

(4) Precautions

Set the signal generator output level to approx. 0 to -10 dBm.

(5) Procedure

Step	Procedure
1	Press the MS8604A [Preset] key.
2	Perform frequency calibration (Spectrum → F6 → F4 → F3).
3	Set the output frequency of signal generator to as listed in the table below.
4	Set the MS8604A to the center frequency in the following table.
5	Set the span that corresponds to the center frequency in the table by using the numeric/unit keys.
6	Read the marker frequency (indicated by thick arrow in the figure on the previous page) and check that the value is within the range between the maximum and minimum values shown in the following table.
7	Repeat steps 3 to 6 for other combination of the center frequency and span according to the combinations shown in the following table.

Center-Frequency Readout-Accuracy Test

Signal generator output frequency	Center frequency	Span frequency	Band (Mixer order)	Center frequency readout		
				Minimum value	Marker value	Maximum value
500 MHz	500 MHz	2 kHz	0 (1)	499.999 95 MHz		500.000 05 MHz
		200 kHz		499.995 MHz		500.005 MHz
		2 MHz		499.95 MHz		500.05 MHz
		10 MHz		499.75 MHz		500.25 MHz
		100 MHz		497.5 MHz		502.5 MHz
5 GHz	5 GHz	2 kHz	1 ⁻ (1)	4.999 999 95 GHz		5.000 000 05 GHz
		200 kHz		4.999 995 GHz		5.000 005 GHz
		2 MHz		4.999 95 GHz		5.000 05 GHz
		10 MHz		4.999 75 GHz		5.000 25 GHz
		100 MHz		4.997 5 GHz		5.002 5 GHz
7.5 GHz	7.5 GHz	2 kHz	1 ⁺ (1)	7.499 999 95 GHz		7.500 000 05 GHz
		200 kHz		7.499 995 GHz		7.500 005 GHz
		2 MHz		7.499 95 GHz		7.500 05 GHz
		10 MHz		7.499 75 GHz		7.500 25 GHz
		100 MHz		7.497 5 GHz		7.502 5 GHz

5.3.3 Frequency span readout accuracy

Using the setup shown in the figure below, set the frequencies corresponding the 1st and 9th division from the left side of the CRT scale with the SG. The frequency difference between the peak levels at the 1st and 9th divisions is equal to the frequency span $\times 0.8$.

(1) Specifications

- Frequency span accuracy: $\pm 2.5\%$ (span ≥ 1 kHz)
 $\pm 5\%$ (100 Hz \leq span < 1 kHz)

(2) Test instrument

- Synthesized signal generator: MG3633A
 Wiltron 6769B

(3) Setup

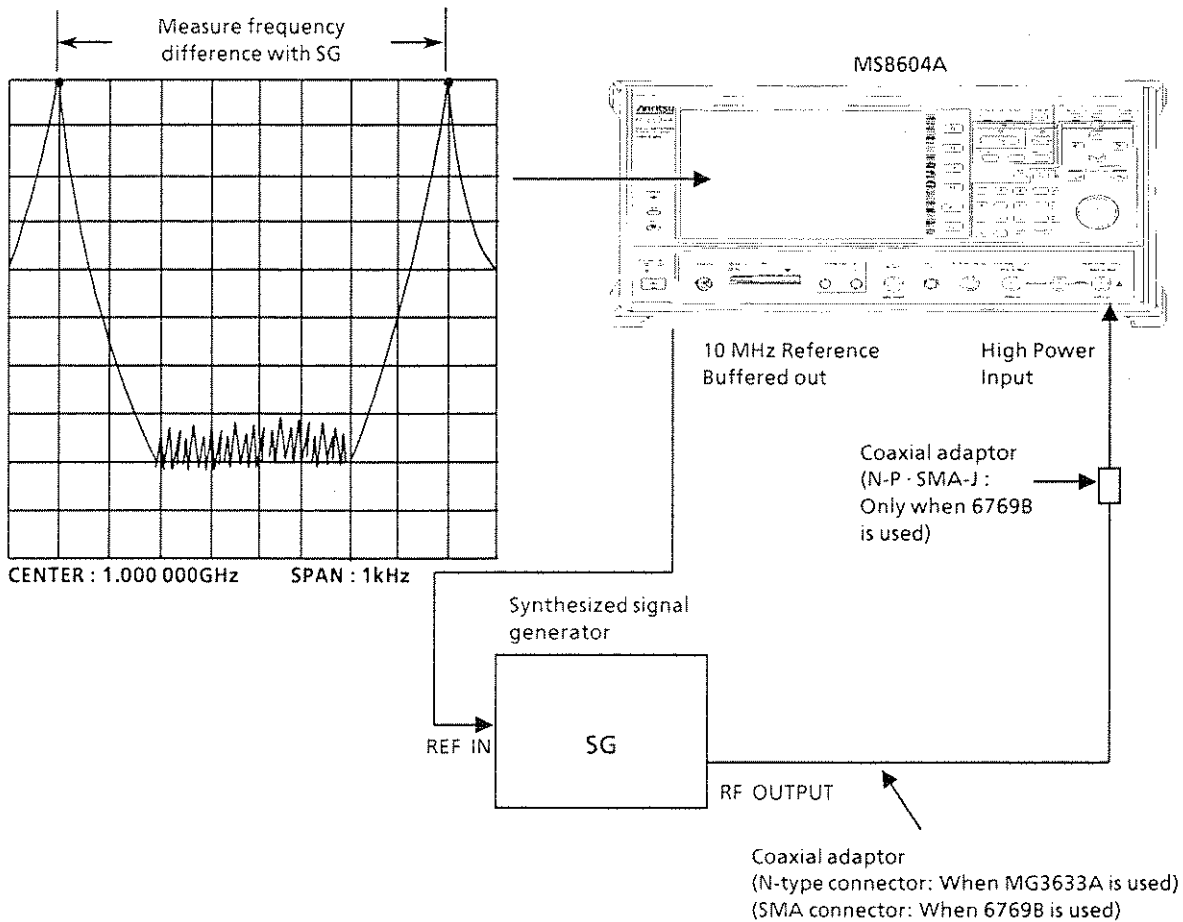

Frequency Span Readout Accuracy Test

(4) Precautions

Set the signal generator output level to approx. 0 to -10 dBm.

(5) Procedure

Step	Procedure
1	Press the MS8604A [Preset] key.
2	Perform frequency calibration (Spectrum → F6 → F4 → F3).
3	Connect the MG3633A output to the MS8604A High Power Input.
4	Set the MS8604A as shown below: SPAN 2 kHz CENTER FREQ 1000 MHz
5	Set the MG3633A output frequency to the f_1 frequency (999.999 2 MHz) shown in the table on the next page.
6	Adjust the MG3633A output frequency to set the spectrum peak at the 1st division from the left end of the CRT scale. Remember the frequency as f_1' .
7	After setting the MG3633A output frequency to the f_2 frequency (1000.000 8 MHz), adjust it to set the spectrum peak at the 9th division. Remember the frequency as f_2' .
8	Calculate $(f_2' - f_1')$ and check that the value is within the specified range (minimum to maximum values) shown in the table on the next page.
9	Repeat steps 4 to 8 for frequencies other than the span 2 kHz and the center frequency 1000 MHz according to the combinations of frequency span and center frequency shown in the table on the next page.
10	Connect the Wiltron 6769B output to the MS8604A High Power Input.
11	Repeat the steps 4 to 8 for each span of the 4.25 GHz center frequency.

Frequency-Span Readout-Accuracy Test

MS8604A		Signal generator				
Center frequency	Span frequency	f_1	f_2	Minimum value	$\frac{f_2' - f_1'}{0.8}$	Maximum value
1 GHz	2 kHz	0.999 999 2 GHz	1.000 000 8 GHz	1.95 kHz		2.05 kHz
	20 kHz	0.999 99 2 GHz	1.000 008 GHz	19.5 kHz		20.5 kHz
	200 kHz	0.999 92 GHz	1.000 08 GHz	195 kHz		205 kHz
	2 MHz	0.999 2 GHz	1.000 8 GHz	1.95 MHz		2.05 MHz
	10 MHz	0.996 GHz	1.004 GHz	9.75 MHz		10.25 MHz
	100 MHz	0.96 GHz	1.04 GHz	97.5 MHz		102.5 MHz
	2 GHz	0.2 MHz	1.8 GHz	1.95 GHz		2.05 GHz
4.25 GHz	100 MHz	4.21 GHz	4.29 GHz	97.5 MHz		102.5 MHz
	1 GHz	3.85 GHz	4.65 GHz	0.975 GHz		1.025 GHz
	8.5 GHz	0.85 GHz	7.65 GHz	8.2875 GHz		8.7125 GHz

5.3.4 Amplitude scale linearity

Test the error per vertical scale graduation for the LOG display. For the LOG display linearity, test that the graduation is in proportion to the logarithm (dB) of the input signal level.

Input the correct level signal to the High Power Input via an external attenuator and calculate the error from the attenuation of the attenuator and the Δ marker reading at the trace waveform peak.

(1) Specifications

- Amplitude scale linearity:

	After automatic calibration
LOG:	± 1.5 dB for 0 to -80 dB (RBW ≤ 10 kHz)
	± 1 dB for 0 to -60 dB (RBW ≤ 100 kHz)
	± 0.3 dB for 0 to -20 dB (RBW ≤ 1 MHz)

(2) Test instruments

- Signal generator: MG3633A
- Attenuator: MN510C

(3) Setup

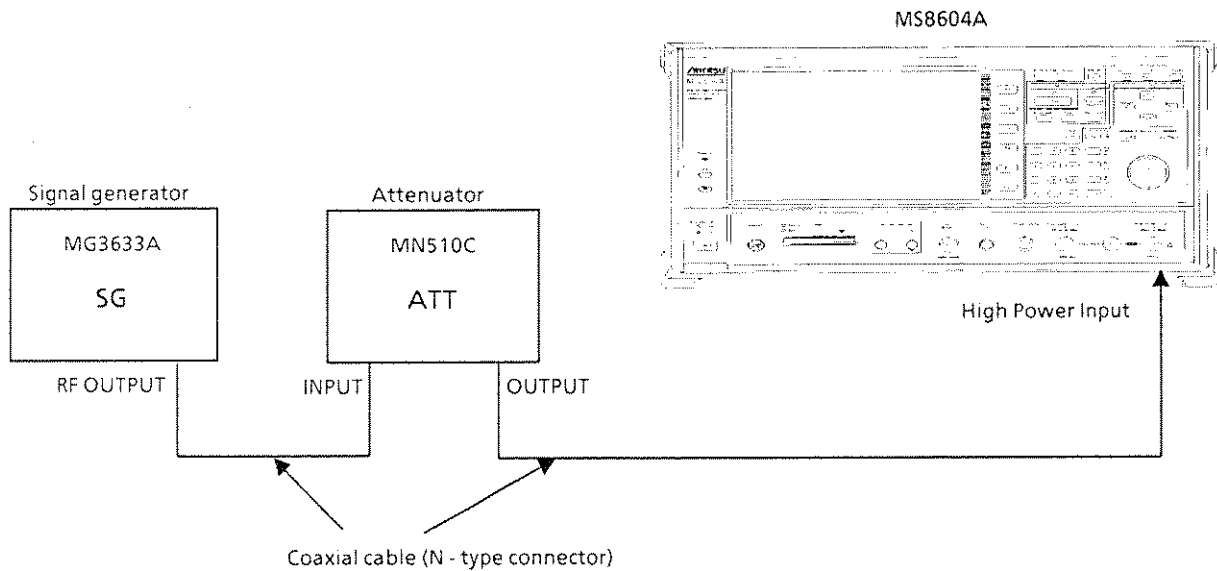

Amplitude Scale Linearity Test

(4) Procedure

LOG display linearity

Step	Procedure
1	Press the MS8604A [Preset] key.
2	Perform all calibration (Spectrum → F6 → F4 → F1).
3	Set the MG3633A to 100 MHz and +10 dBm.
4	Set the MN510C to 0 dB.
5	Set the MS8604A as shown below: CENTER FREQ 100 MHz SPAN 10 kHz REF LEVEL +10 dBm ATT 25 dB RBW 3 kHz VBW 300 Hz
6	Align the marker with the peak level (Spectrum → F1 → F3).
7	Set the MKR to CF (F6 → F1 → F4 → F1).
8	Adjust the MG3633A output level so that the marker level reading is +10.0 dBm.
9	Press the [F6] and [F2] keys sequentially to set the marker to Δ marker after the sweep is completed (see figure (a) below).
10	Read the current marker level when ATT is set to 5 dB (figure (b) below). Find the error by adding the ATT 5 dB corrected value to Δ marker level (see the table on the next page).
11	Find the error by adding the Δ marker level to the corresponding ATT corrected value when ATT is set to 10 to 80 dB (5 dB steps) as shown in the figure on the next page.

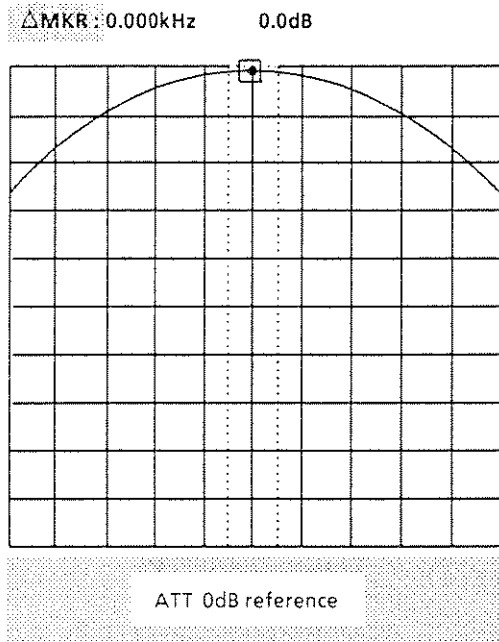

(a) Reference Point Setting

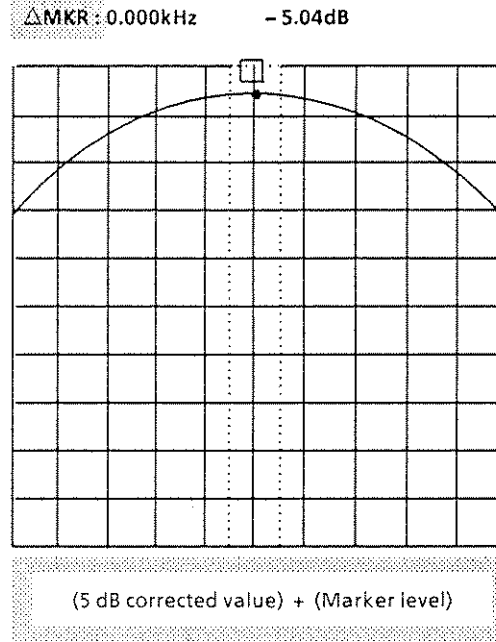

(b) Δ Marker Level when ATT is 5 dB

LOG Display Linearity (10 dB/div)

ATT setting (dB)	A	B	Error (dB) = A + B
	ATT calibration value (dB)	Δ marker level (dB)	
0	0 (reference)	0 (reference)	0 (reference)
5	_____	_____	_____
10	_____	_____	_____
15	_____	_____	_____
20	_____	_____	_____
25	_____	_____	_____
30	_____	_____	_____
35	_____	_____	_____
40	_____	_____	_____
45	_____	_____	_____
50	_____	_____	_____
55	_____	_____	_____
60	_____	_____	_____
65	_____	_____	_____
70	_____	_____	_____
75	_____	_____	_____
80	_____	_____	_____

5.3.5 Frequency characteristics

Generally, when one or more signals with a different frequency but the same amplitude are input, the spectrum analyzer displays the same amplitude for each spectrum on the CRT.

(1) Specifications

- Frequency characteristics: At Temperature 18 ° to 28 °C for input ATT 30 dB with 100 MHz as reference
 ± 0.5 dB (100 Hz to 2.0 GHz, band 0)
 ± 1 dB (1.7 GHz to 8.5 GHz, band 1⁻, band 1⁺)

(2) Test instruments

- Signal generator: Wiltron 6769B
- Power meter: ML4803A
- Power sensor: MA4701A

(3) Setup

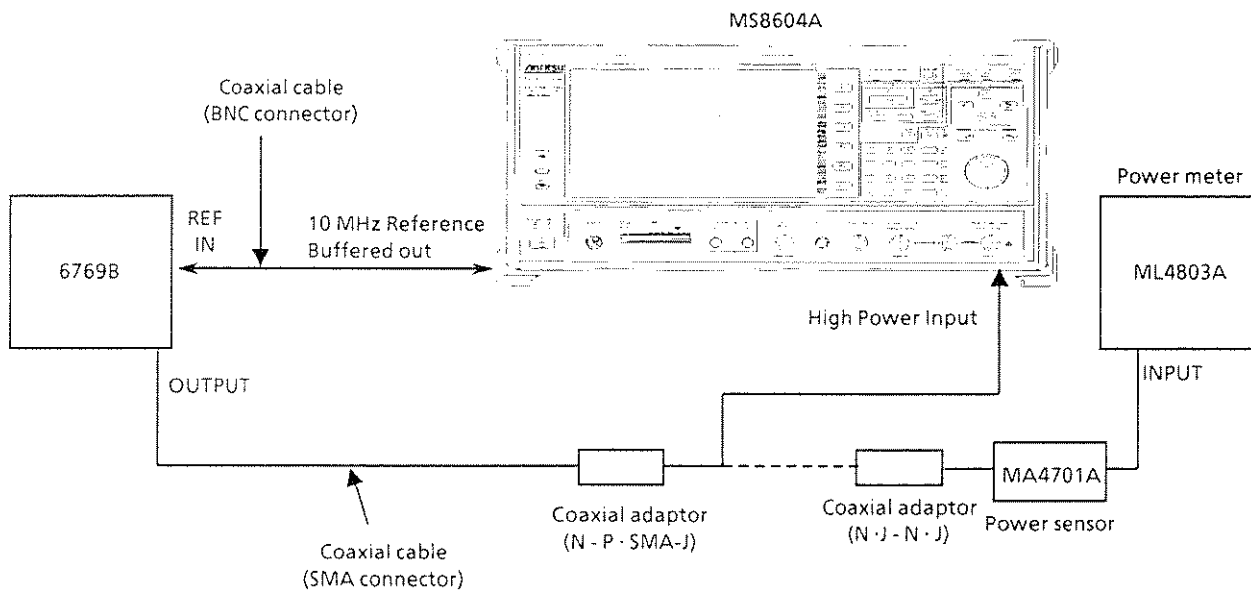

Frequency Characteristics Test

(4) Precautions

This test should be performed at an ambient temperature of 18 ° to 28 °C after allowing the instrument to warm up for 60 minutes or more.

(5) Procedure**(a) Calibration of signal-generator 6769B**

Step	Procedure
1	Set the 6769B as shown below: OUTPUT FREQ 100 MHz OUTPUT LEVEL 0 dBm
2	Connect the 6769B output to the power sensor input with a coaxial cable.
3	Read the power meter display.
4	Change the 6769B output frequency as shown in the tables on the next page and read the power meter display with level at 100 MHz as reference. This data is the calibration data.

(b) Readout of measured amplitude deviation (Frequency characteristics)

Step	Procedure
1	Press the MS8604A [Preset] key.
2	Perform all calibration (Spectrum → F6 → F4 → F1).
3	Connect the 6769B OUTPUT to MS8604A High Power Input with a coaxial cable.
4	Set the MS8604A as shown below: CENTER FREQ: 100 MHz SPAN: 200 kHz BAND: 0 REF LEVEL: 0 dBm
5	Align the marker with the peak level (Spectrum → F1 → F3).
6	Set the MKR to CF (F6 → F1 → F4 → F1).
7	Set the marker mode to delta marker.
8	Set the MS8604A frequency band and center frequency as shown in the tables on the next page, then obtain the deviation from the formula below by reading the delta marker level at each frequency. $\text{Deviation} = \text{Delta marker level reading} - \text{Measurement frequency calibration value}$ For band ¹⁻ and band ¹⁺ , conduct AUTO TUNE every time a frequency is set. (See paragraph 4.4)

Frequency Characteristics (Band 0)

Frequency	Calibration value (dB) ^A	Marker level (dB) ^B	Deviation (dB) ^{B - A}
100 MHz	0 dB (reference)	0 dB (reference)	0 dB (reference)
200 MHz	_____	_____	_____
500 MHz	_____	_____	_____
1 GHz	_____	_____	_____
1.5 GHz	_____	_____	_____
2 GHz	_____	_____	_____

Frequency Characteristics (Band 1 -)

Frequency	Calibration value (dB) ^A	Marker level (dB) ^B	Deviation (dB) ^{B - A}
1.7 GHz	_____	_____	_____
2 GHz	_____	_____	_____
3 GHz	_____	_____	_____
4 GHz	_____	_____	_____
5 GHz	_____	_____	_____
6 GHz	_____	_____	_____
7 GHz	_____	_____	_____
7.5 GHz	_____	_____	_____

Frequency Characteristics (Band 1 +)

Frequency	Calibration value (dB) ^A	Marker level (dB) ^B	Deviation (dB) ^{B - A}
6.5 GHz	_____	_____	_____
7 GHz	_____	_____	_____
7.5 GHz	_____	_____	_____
8 GHz	_____	_____	_____
8.5 GHz	_____	_____	_____

5.3.6 Reference level accuracy

Here the absolute amplitude level at only 100 MHz is tested. Confirm the level accuracy after inputting an SG output (calibrated by a standard power meter) to the MS8604A.

(1) Specifications

- Reference level accuracy: At 100 MHz frequency and ≤ 2 MHz span after automatic calibration (Resolution bandwidth, video bandwidth and sweep time set to AUTO)
 - $\leq \pm 0.5$ dB (+20 to -30 dBm)
 - $\leq \pm 0.75$ dB (-40 to -30 dBm, +20 to +40 dBm)
 - $\leq \pm 1.5$ dB (-60 to -40 dBm)

(2) Test instruments

- Signal generator: MG3633A
- Attenuator: MN510C
- Power sensor: MA4601A
- Power meter: ML4803A

(3) Setup

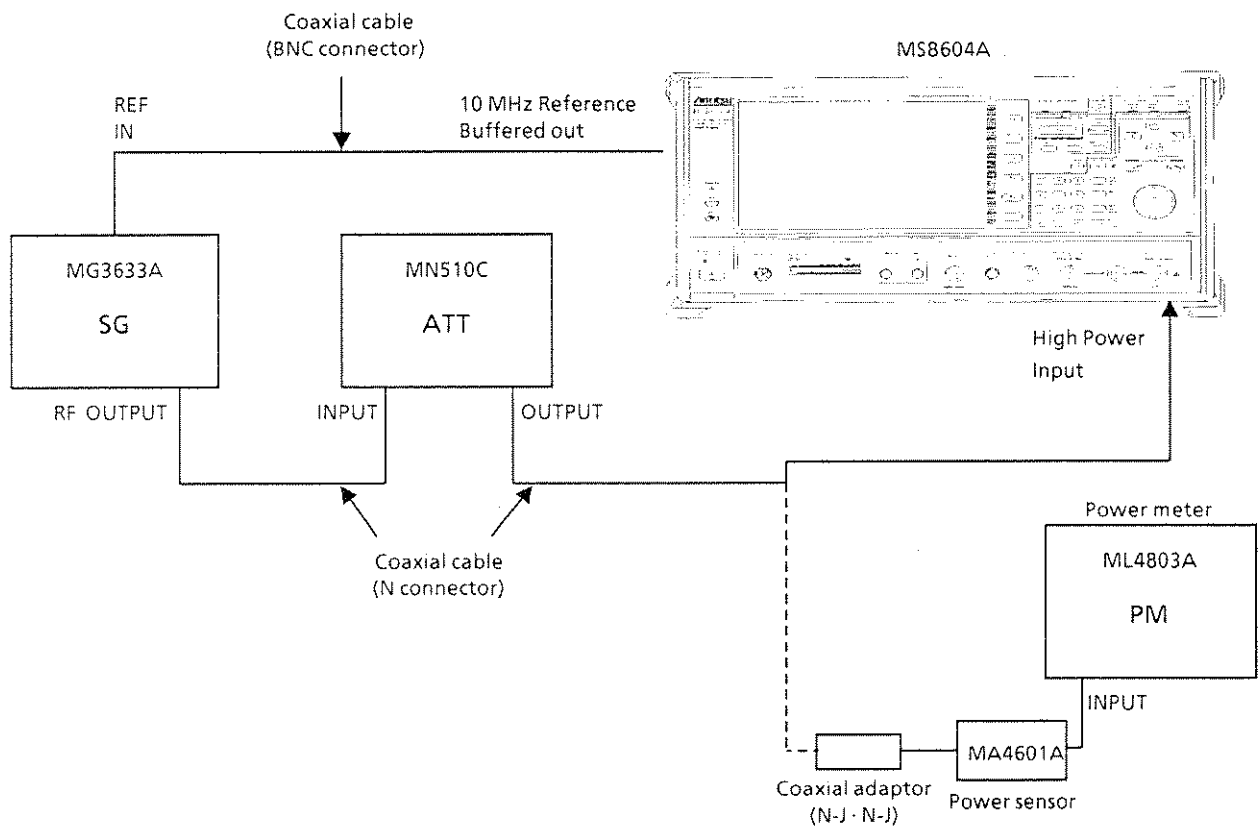

Reference Level Accuracy Test

(4) Precautions

1. Set the resolution bandwidth, video bandwidth and sweep time to Auto.
2. This test should be performed after warming up this instrument for 60 minutes or more.

(5) Procedure

Step	Procedure
1	Press the MS8604A [Preset] key.
2	Perform all calibration (Spectrum → F6 → F4 → F1).
3	Connect the attenuator OUTPUT to the power sensor input.
4	Set the SG frequency to 100 MHz and adjust the SG level so that the power meter indication is 0 dBm. At this time, set the attenuator to +10 dB.
5	Connect the attenuator OUTPUT to the MS8604A RF Input connector.
6	Set the MS8604A as shown below: CENTER FREQ 100 MHz SPAN 200 kHz REF LEVEL +10 dBm
7	Align the marker with the peak level (Spectrum → F1 → F3).
8	Set the MKR to CF (F6 → F1 → F4 → F1).
9	Read the marker level.
10	Change the attenuator in 10 dB steps, set the reference level as shown in the table below and read the marker level each time.

Reference level setting ^A	Marker level value ^B	Calibrated attenuation value ^C	^{B - A - C} Error (dB)
+10 dBm			
0 dBm			
-10 dBm			
-20 dBm			
-30 dBm			
-40 dBm			
-50 dBm			
-60 dBm			
-70 dBm			
-80 dBm			

- 11 Find the error from the following equation.

$$\text{Error} = \text{marker level value} - \text{reference level set value} - \text{calibrated attenuation value}$$

5.3.7 Instrument accuracy and zero shift between ranges

Measurement accuracy of the power meter at full scale in each range is called the instrument accuracy.

The zero shift between ranges represents shift of the zero point between ranges, which occurs because of noise and drift, after zero point adjustment at the maximum range.

(1) Specifications

- Instrument accuracy: $\pm 0.5\%$
- Zero shift between ranges: $\pm 0.2\%$ of full scale after zero point adjustment at maximum range

(2) Equipment required

- Range calibrator: MA4001A

(3) Setup

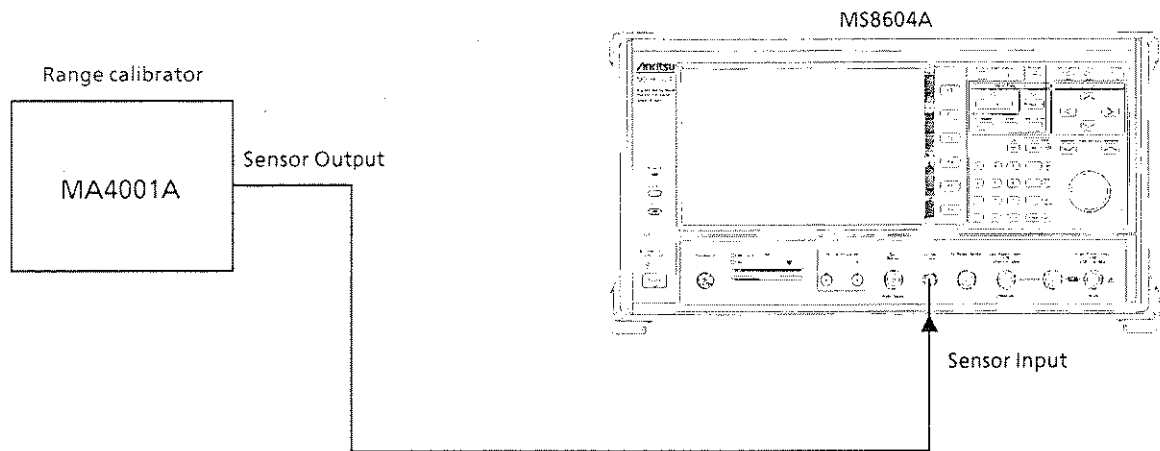

(4) Precaution

Conduct warm-up run for at least 30 minutes before tests.

(5) Test Procedure 1: Instrument accuracy

Step	Procedure
1	Set the MS8604A power meter as listed below: SENSOR CONNECT TO: DUT RANGE: AUTO CAL FACTOR Sensor: 0.00 dB User: 0.00 dB Reference: 0.00 dB
2	Set the range calibrator range to the -20 to $+20$ dBm side. Then, set RANGE (dBm) to ZERO.
3	Conduct ZERO SET for the MS8604A and check that the WATT meter reads 0.0 ± 0.1 . If not, conduct ZERO SET again. [CALIBRATION] (F4) → [ZERO SET] (F5)
4	Set RANGE (dBm) of the range calibrator to 0 dBm.
5	Check that the WATT meter reads 1.000 ± 0.002 . If not, conduct CAL ADJ (F4 key) of the MS8604A.
6	Return the RANGE (dBm) setting of the range calibrator to ZERO and repeat step 4.
7	Change the RANGE (dBm) setting of the range calibrator sequentially to -10 , 0 , $+10$ and $+20$ dBm. Check that the readings on MS8604A meet the ranges listed in the table below (between maximum and minimum).

Instrument Accuracy Test

Range calibrator RANGE (dBm)	WATT indication			dBm indication		
	Minimum	Actual	Maximum	Minimum	Actual	Maximum
-10 dBm ($100\mu\text{W}$)	99.5	—	100.5	-10.02	—	-9.98
0 dBm (1mW)	0.995	—	1.005	-0.02	—	$+0.02$
$+10$ dBm (10mW)	9.95	—	10.05	$+9.98$	—	$+10.02$
$+20$ dBm (100mW)	99.5	—	100.5	$+19.98$	—	$+20.02$

Test Procedure 2: Zero shift between ranges

Step	Procedure
1	Set the MS8604A power meter as listed below: SENSOR CONNECT TO: DUT RANGE: AUTO CAL FACTOR Sensor: 0.00 dB User: 0.00 dB Reference: 0.00 dB
2	Set the range calibrator range to the -20 to $+20$ dBm side. Then, set RANGE (dBm) to 0 dBm.
3	Conduct ZERO SET for the MS8604A and then zero point adjustment at the maximum range. After adjustment, check that the WATT meter reads 0.0 ± 0.1 .
4	Set the range of range calibrator to -25 to $+15$ dBm.
5	Set RANGE (dBm) of the range calibrator as listed in the table below.
6	Set RANGE of the MS8604A to HOLD and RANGE (dBm) of the range calibrator to ZERO. Check that WATT meter readings are within ranges specified in the table.
7	Set RANGE of the MS8604A to AUTO.
8	Repeat steps 2 through 7 in the same way and check that readings are within ranges specified in the table.

Zero Shift between Ranges

RANGE (dBm) of range calibrator at step 5	Power meter range	WATT indication		
		Minimum	Actual	Maximum
-5 dBm	0 dBm (1 mW)	-0.002	—	0.002
$+5$ dBm	$+10$ dBm (10 mW)	-0.02	—	0.02
$+15$ dBm	$+20$ dBm (100 mW)	-0.2	—	0.2

5.3.8 Calibration oscillator output accuracy

The calibrator oscillator output is adjusted to $1 \text{ mW} \pm 0.7 \%$ at the factory. At the factory, the standard signal generator with high output accuracy (National Bureau Standards traceable) is used for adjustment for the calibrator oscillator output of the power meter.

Here, the test procedure for testing the calibration oscillator output using the HP435A-K06 (NBS traceable) is instructed. The trace error after calibration using this procedure will be within $\pm 0.4 \%$. The output accuracy guaranteed for the HP435A-K06 is $\pm 1.2 \%$. Consequently, calibration accuracy with this procedure is $\pm 1.6 \%$.

(1) Specification

- Output level accuracy: $1.00 \text{ mW} \pm 1.2 \%$

(2) Equipment required

- Standard output signal generator: HP 435A-K06
- Power meter: ML4803A
- Power sensor: MA4701A

(3) Setup

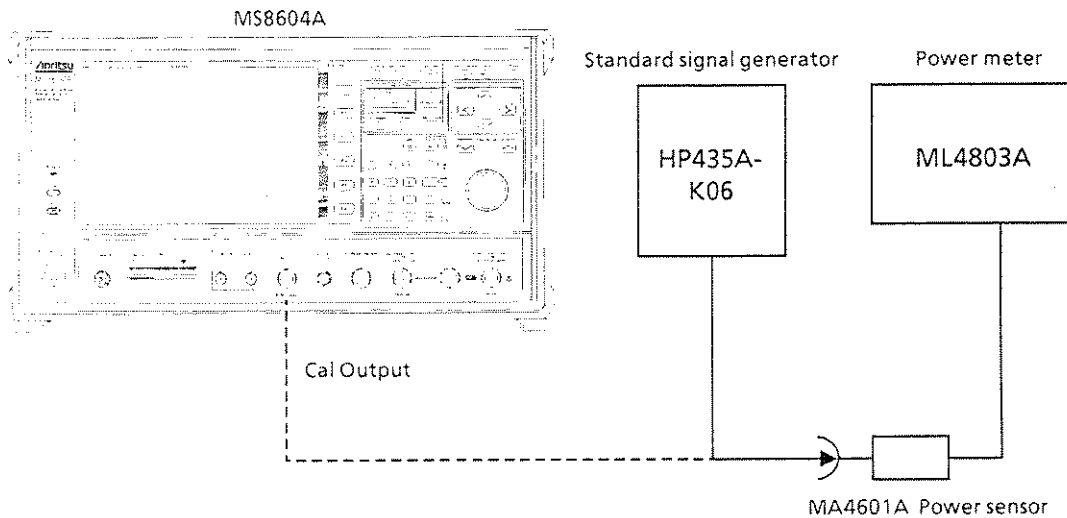

(4) Test Procedure: Calibration oscillator output accuracy

Step	Procedure
1	<p>Set power meter ML4803A as listed below:</p> <p>MODE: WATT AVERAGE: OFF RANGE HOLD: OFF CAL F: REFERENCE CAL FACTOR of power sensor OFFSET: 0.00 dB REF: --- dBm MEMORY function: OFF</p>
2	Set the CAL OSCILLATOR ON/OFF of the MS8604A to OFF.
3	Set the output of standard signal generator to OFF and connect sensor MA4701A to the output terminal of standard signal generator.
4	Conduct zero point adjustment for power meter ML4803A. Then, set OUTPUT ON/OFF key of standard signal generator source to ON and measure the output level.
5	If the power meter reading is out of the 1.000 ± 0.002 range, press the CAL OUTPUT ON key and then the ADJ key. (The ADJ key of ML4803A is effective only when the CAL OUTPUT ON key is set to ON.)
6	Disconnect the sensor from the output terminal of standard signal generator source and connect it to the CAL OUTPUT terminal of MS8604A.
7	Conduct the zero point adjustment of power meter ML4803A again. Then, set CAL OSCILLATOR ON/OFF of the MS8604A to ON and measure the output level. Check that the measured value meets the specification shown in the table below.

Calibration Oscillator Output Accuracy Test

Minimum	Actual	Maximum
0.972 mW	—	1.028 mW

5.3.9 PDC frequency/modulation accuracy

Supply a non-modulated signal with frequency deviated from the signal generator and use it as the quasi signal modulated by "00" data.

(1) Specifications

- Carrier frequency accuracy: \pm (reference crystal oscillator accuracy + 1 Hz)
- Modulation accuracy: \pm (2 % of reading + 0.5 %)

(2) Equipment required

- Synthesized signal generator: MG3633A
- Power meter: ML4803A
- Power sensor: MA4601A
- 4-port combining pad: MA1612A

(3) Setup

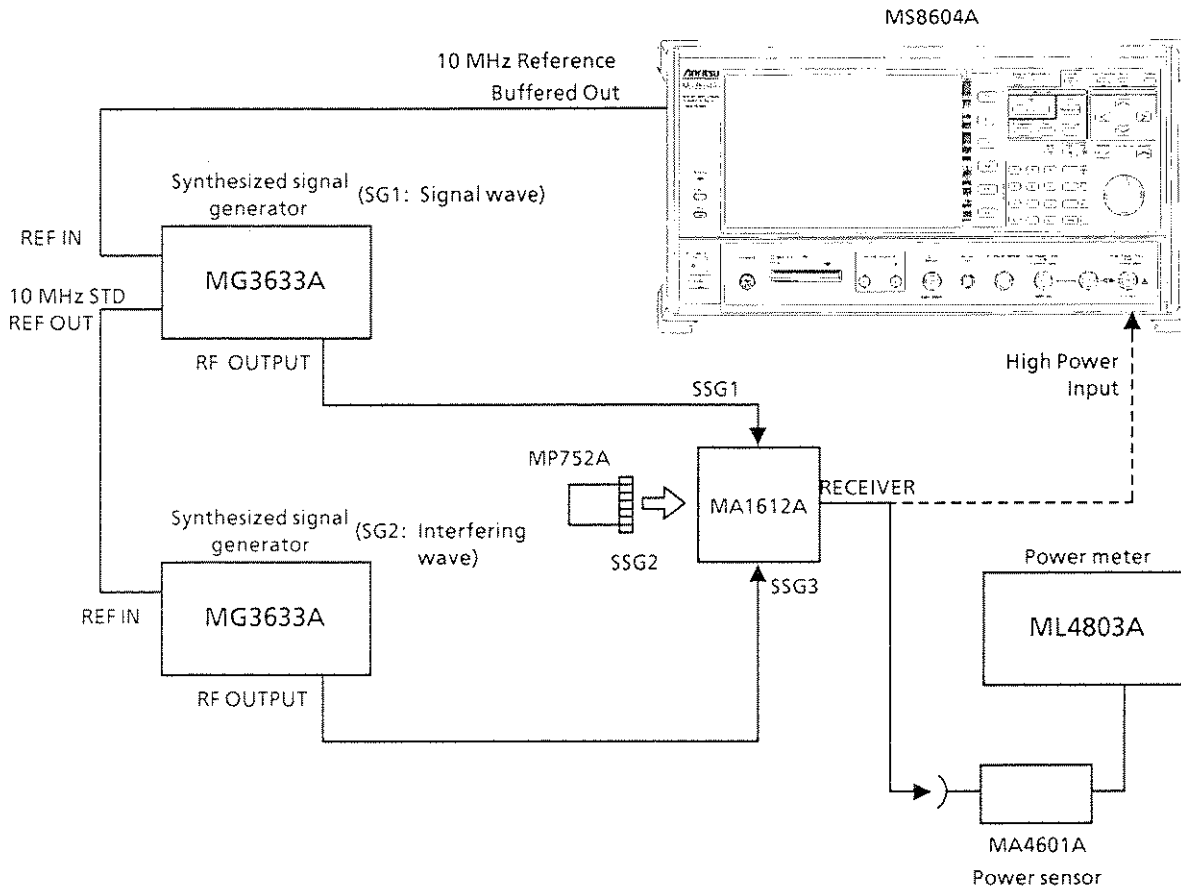

5.3.10 PDC transmission power accuracy

Test the power measurement function using non-modulated, continuous wave supplied from the signal generator.

(1) Specification

- Transmission power accuracy: $\pm 10\%$ after calibration by power sensor MA4601A using High Power Input terminal

(2) Equipment required

- Signal generator: MG3633A

(3) Setup

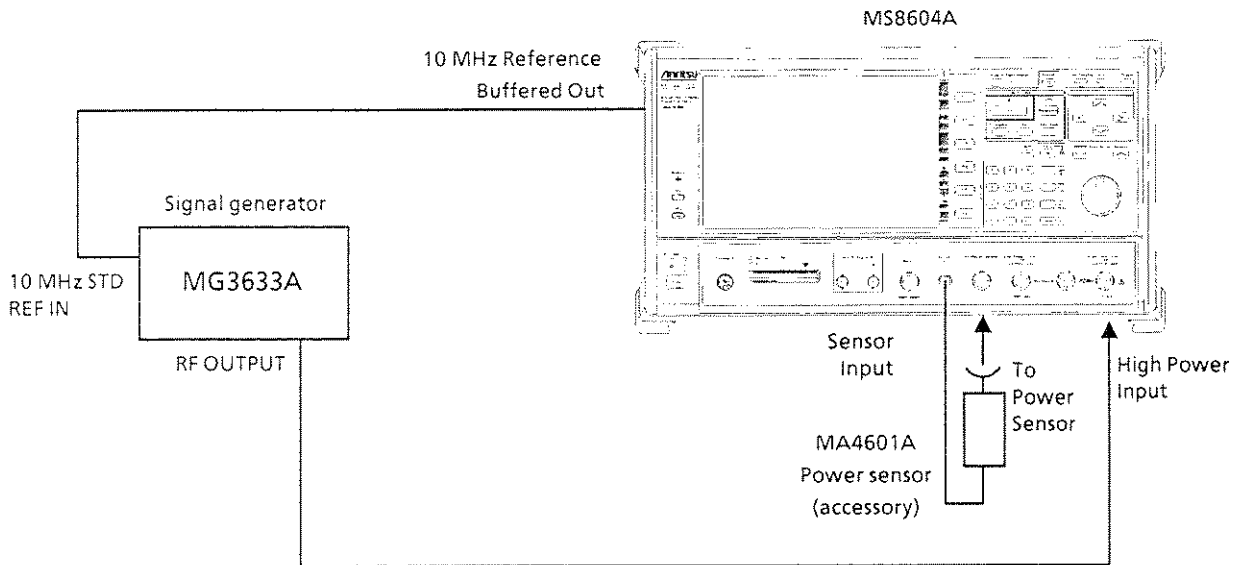

(4) Test Procedure: PDC transmission power accuracy

Step	Procedure
1	Set the signal generator MG3633A as listed below: FREQUENCY: 1000 MHz OUTPUT LEVEL: +10 dBm
2	Set the power meter of the MS8604A as listed below: SENSOR CONNECT TO: TESTER RANGE: AUTO CAL FACTOR Sensor: CAL FACTOR of sensor MA4601A at 1000 MHz User: 0.00 dB Reference: REFERENCE CAL FACTOR of sensor MA4601A CONDITION Frequency: 1000 MHz
3	Read the indicated value on the power meter screen of the MS8604A.
4	Set the MS8604A to the PDC Setup screen and set as listed below: INPUT Terminal: RF Measuring object: BS-COM FREQUENCY: 1000 MHz SYNC WORD Pattern: NO
5	Press the [RF POWER] (F1) key of the MS8604A and execute the AUTO RANGE. [CALIBRATION] (F4) → [AUTO RANGE] (F1)
6	Read the TX power value indicated on the MS8604A. Check that the measured value is the same as that in step 3 (within ± 0.1 dB). The TX power accuracy checked here is equivalent to the power meter accuracy.

PDC Transmission Power Accuracy Test

Actual power meter reading (dBm)	TX power measured value (dBm)

(4) Test Procedure: PHS frequency/modulation accuracy

Step	Procedure
1	Set the signal generator MG3633A as listed below: SG1 (signal wave): FREQ: Frequencies of table + 24 kHz *1 Non-modulated SG2 (interfering wave): FREQ: Frequencies of table + 12 kHz *2 Non-modulated
2	Set the SG1 output to ON and the SG2 output to OFF. Adjust the SG1 output level so that the power meter ML4803A reads 0 dBm and press the dB (REL) key of the ML4803A.
3	Set the SG1 output to OFF and the SG2 output to ON. Adjust the SG2 output level so that the power meter ML4803A reads -18.06 ± 0.05 dB.
4	Set the MS8604A as listed below: INPUT Terminal: RF RF level: 0 dBm Measuring object: CONTINUOUS FREQUENCY: Frequencies listed in the table below UNIQUE WORD Pattern: NO
5	Set the SG1 output to ON and the SG2 output to OFF.
6	Press the [MODULATION ANALYSIS] (F1) key of the MS8604A and read indicated carrier frequency error and RMS vector error. The read RMS vector error represents the residual vector error of the MS8604A.
7	Set SG1 and SG2 outputs to ON and read the RMS vector error. Check that the measured value is within the specified range (between the minimum and maximum).
8	Repeat steps 1 through 7 for all frequencies listed in the table.

PHS Frequency/Modulation Accuracy Test

Frequency (MHz)	Carrier frequency error			RMS vector error					
	Frequency measurement accuracy (kHz)			Residual vector error (%)			Modulation accuracy (%)		
	Minimum	Actual	Maximum	Minimum	Actual	Maximum	Minimum	Actual	Maximum
10	-0.010	—	+0.010	0.00	—	0.70	11.55	—	13.45
1000	-0.010	—	+0.010	0.00	—	0.70	11.55	—	13.45
2000	-0.010	—	+0.010	0.00	—	0.70	11.55	—	13.45

*1: The frequency when the phase change is $+45$ %/symbol (equivalent to all 0 modulation at PHS) is calculated as:

$$(\text{Symbol rate})/8 = 192 \text{ kHz}/8 = 24 \text{ kHz}$$

*2: $12 \text{ kHz} = (\text{symbol rate})/16 = 192 \text{ kHz}/16$

5.3.12 PHS transmission power accuracy

Test the power measurement function using non-modulated, continuous wave supplied from the signal generator.

(1) Specification

- Transmission power accuracy: $\pm 10\%$ after calibration by the power sensor MA4601A using High Power Input terminal

(2) Equipment required

- Signal generator: MG3633A

(3) Setup

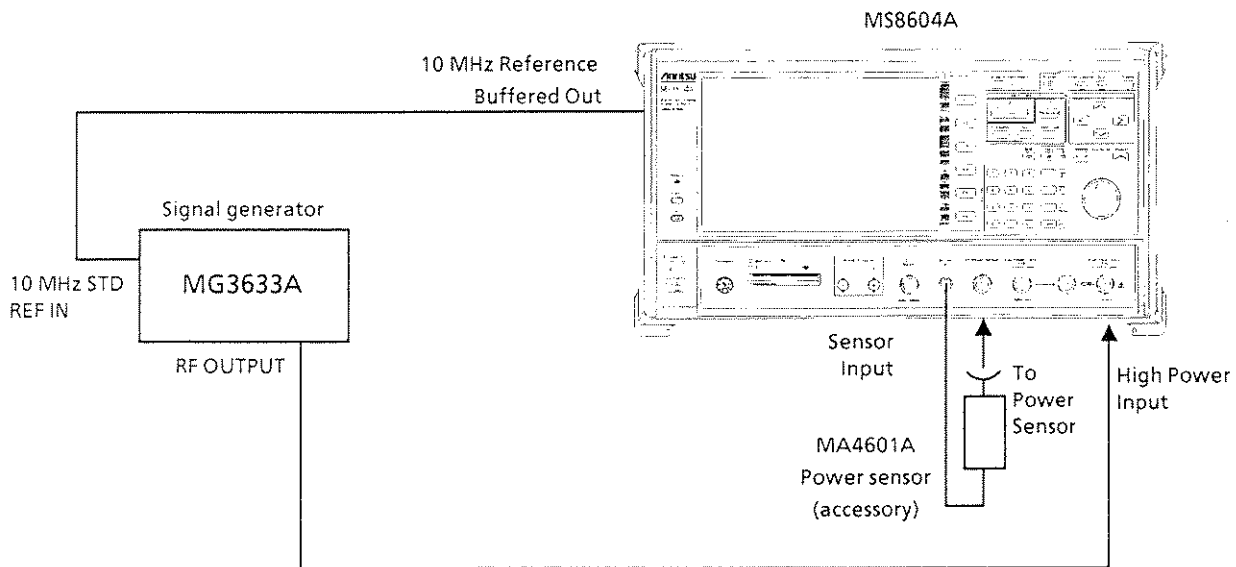

(4) Test Procedure: PHS transmission power accuracy

Step	Procedure
1	Set signal generator MG3633A as listed below: FREQUENCY: 1000 MHz OUTPUT LEVEL: +10 dBm
2	Set the power meter of MS8604A as listed below: SENSOR CONNECT TO: TESTER RANGE: AUTO CAL FACTOR Sensor: CAL FACTOR of the sensor MA4601A at 1000 MHz User: 0.00 dB Reference: REFERENCE CAL FACTOR of the sensor MA4601A CONDITION Frequency: 1000 MHz
3	Read the indicated value on the power meter screen of the MS8604A.
4	Set the MS8604A to the PHS Setup screen and set as listed below: INPUT Terminal: RF Measuring object: CONTINUOUS FREQUENCY: 1000 MHz UNIQUE WORD Pattern: NO
5	Press the [RF POWER] (F1) key of the MS8604A and execute the AUTO RANGE. [CALIBRATION] (F4) → [AUTO RANGE] (F1)
6	Read the TX power value indicated on the MS8604A. Check that the measured value is the same as that in step 3 (within ± 0.1 dB). The TX power accuracy checked here is equivalent to the power meter accuracy.

PHS Transmission Power Accuracy Test

Actual power meter reading (dBm)	TX power measured value (dBm)

5.3.13 NADC frequency/modulation accuracy

Supply a non-modulated signal with frequency deviated from the signal generator and use it as the quasi signal modulated by "00" data.

(1) Specifications

- Carrier frequency accuracy: \pm (reference crystal oscillator accuracy + 1 Hz)
- Modulation accuracy: \pm (2 % of reading + 0.5 %)

(2) Equipment required

- Synthesized signal generator: MG3633A
- Power meter: ML4803A
- Power sensor: MA4601A
- 4-port combining pad: MA1612A

(3) Setup

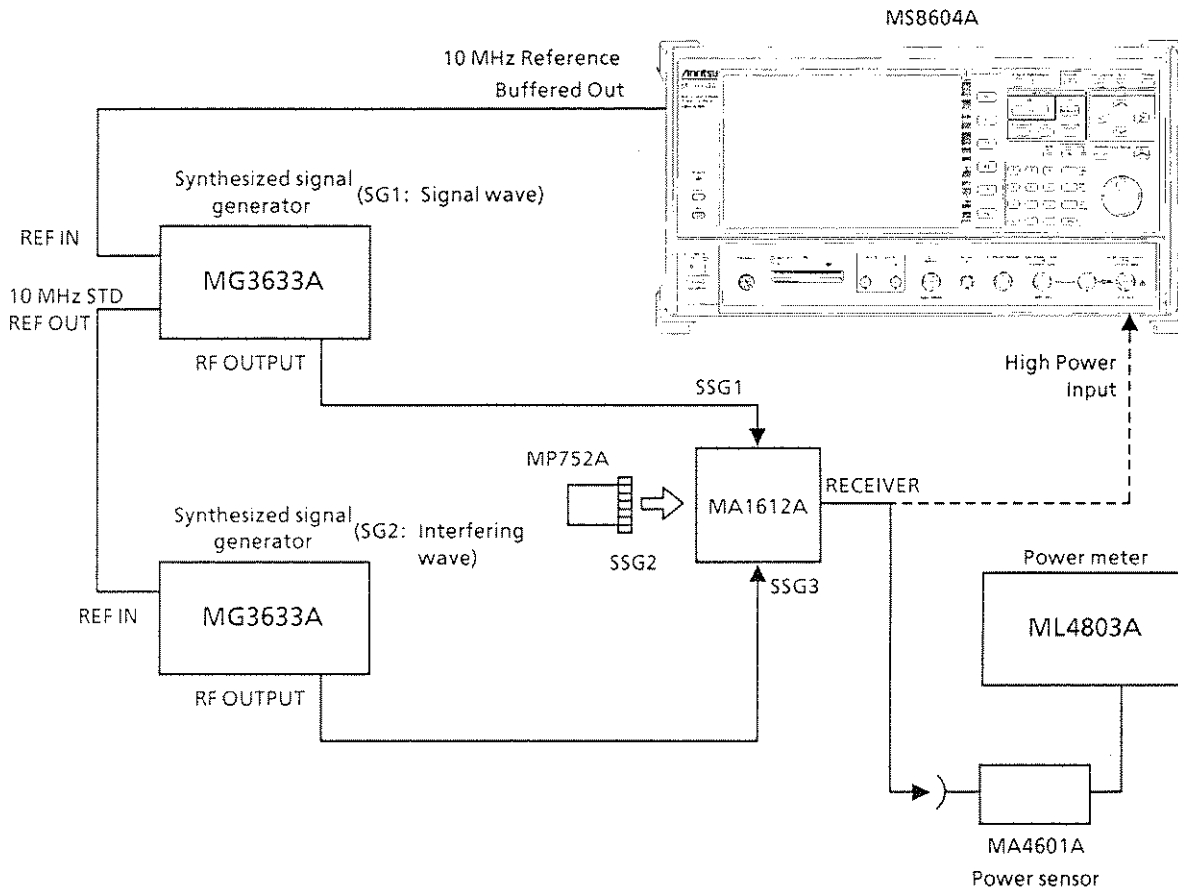

(4) Test Procedure: NADC frequency/modulation accuracy

Step	Procedure
1	Set the signal generator MG3633A as listed below: SG1 (signal wave): FREQ: Frequencies of table + 3.037 5 kHz *1 Non-modulated SG2 (interfering wave): FREQ: Frequencies of table + 1.518 75 kHz*2 Non-modulated
2	Set the SG1 output to ON and the SG2 output to OFF. Adjust the SG1 output level so that power meter ML4803A reads 0 dBm and press the dB (REL) key of the ML4803A.
3	Set the SG1 output to OFF and the SG2 output to ON. Adjust the SG2 output level so that power meter ML4803A reads -18.06 ± 0.05 dB.
4	Set the MS8604A as listed below: INPUT Terminal: RF RF level: 0 dBm Measuring object: BASE FREQUENCY: Frequencies listed in the table below SYNC WORD Pattern: NO
5	Set the SG1 output to ON and the SG2 output to OFF.
6	Press the [MODULATION ANALYSIS] (F1) key of the MS8604A and reads indicated carrier frequency error and RMS vector error. The read RMS vector error represents the residual vector error of the MS8604A.
7	Set SG1 and SG2 outputs to ON and read the RMS vector error. Check that the measured value is within the specified range (between the minimum and maximum).
8	Repeat steps 1 through 7 for all frequencies listed in the table.

NADC Frequency/Modulation Accuracy Test

Frequency (MHz)	Carrier frequency error			RMS vector error					
	Frequency measurement accuracy (kHz)			Residual vector error (%)			Modulation accuracy (%)		
	Minimum	Actual	Maximum	Minimum	Actual	Maximum	Minimum	Actual	Maximum
10	-0.001	—	+0.001	0.00	—	0.50	11.75	—	13.25
1000	-0.001	—	+0.001	0.00	—	0.50	11.75	—	13.25
2000	-0.001	—	+0.001	0.00	—	0.50	11.75	—	13.25

*1: The frequency when the phase change is +45 %/symbol (equivalent to all 0 modulation at NADC) is calculated as:

$$(\text{Symbol rate})/8 = 24.3 \text{ kHz}/8 = 3.037 5 \text{ kHz}$$

*2: $1.518 75 \text{ kHz} = (\text{Symbol rate})/16 = 24.3 \text{ kHz}/16$

5.3.14 NADC transmission power accuracy

Test the power measurement function using non-modulated, continuous wave supplied from the signal generator.

(1) Specification

- Transmission power accuracy: $\pm 10\%$ after calibration by the MA4601A using High Power Input terminal

(2) Equipment required

- Signal generator: MG3633A

(3) Setup

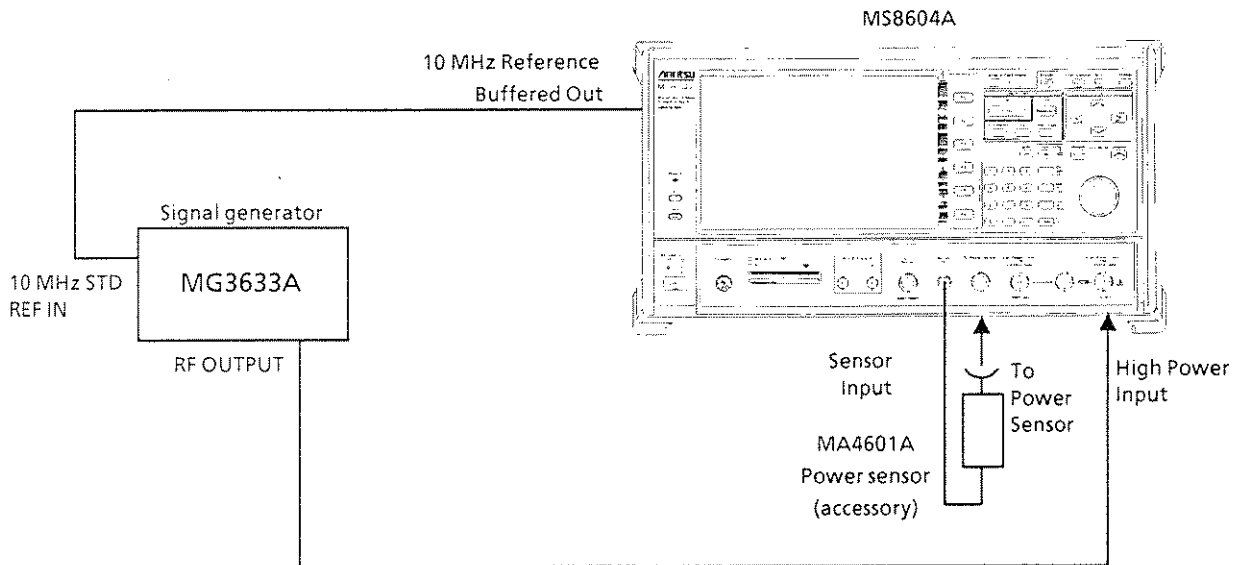

(4) Test Procedure: NADC transmission power accuracy

Step	Procedure
1	Set the signal generator MG3633A as listed below: FREQUENCY: 1000 MHz OUTPUT LEVEL: +10 dBm
2	Set the power meter of the MS8604A as listed below: SENSOR CONNECT TO: TESTER RANGE: AUTO CAL FACTOR Sensor: CAL FACTOR of the sensor MA4601A at 1000 MHz User: 0.00 dB Reference: REFERENCE CAL FACTOR of the sensor MA4601A CONDITION Frequency: 1000 MHz
3	Read the indicated value on the power meter screen of the MS8604A.
4	Set the MS8604A to the NADC Setup screen and set as listed below: INPUT Terminal: RF Measuring object: BASE FREQUENCY: 1000 MHz SYNC WORD Pattern: NO
5	Press the [RF POWER] (F1) key of the MS8604A and execute the AUTO RANGE. [CALIBRATION] (F4) → [AUTO RANGE] (F1)
6	Read the TX power value indicated on the MS8604A. Check that the measured value is the same as that in step 3 (within ± 0.1 dB). The TX power accuracy checked here is equivalent to the power meter accuracy.

NADC Transmission Power Accuracy Test

Actual power meter reading (dBm)	TX power measured value (dBm)

(Blank)

SECTION 6 CALIBRATION

This section describes the measuring instruments required for calibration of the MS8604A, their setup and the calibration method.

TABLE OF CONTENTS

6.1	Requirement for Calibration	6-3
6.2	Equipment Required for Calibration	6-3
6.3	Calibration	6-4
6.3.1	Calibrating reference-crystal-oscillator frequency	6-4

(Blank)

6.1 Requirement for Calibration

Calibration is carried out to help prevent degradation of performance of the MS8604A. Calibration should be performed periodically even if the MS8604A is operating normally.

Contact Anritsu if the MS8604A fails to meet the specifications during calibration.

6.2 Equipment Required for Calibration

The table below lists the equipment required for calibrating each item.

Table of Equipment Required for Calibration

Equipment	Major specification†	Calibration item
Oscilloscope	Capable of measuring 10 MHz (external trigger possible)	Reference-crystal-oscillator frequency accuracy
Frequency standard	Standard radio-wave receiver or equipment having equivalent function (accuracy better than 1×10^{-9})	Reference-crystal-oscillator frequency accuracy

† Extracts part of performance which can cover the measurement range of the test item.

6.3 Calibration

To calibrate the MS8604A, its internal reference oscillator frequency should be calibrated once or twice a year.

6.3.1 Calibrating reference-crystal-oscillator frequency

The stability of the MS8604A reference crystal oscillator is $\pm 2 \times 10^{-8}$ /day. The following describes the method for calibrating the frequency of the reference crystal oscillator by using a reference signal generator generating a reference signal that is either locked to a standard wave, or to a received color-television sub-carrier (signal locked to rubidium atomic standard).

(1) Specifications

Reference crystal oscillator	Frequency	Aging rate	Temperature characteristics
Standard type	10 MHz	$\pm 2 \times 10^{-8}$ /day	$\pm 5 \times 10^{-8}$ (0 to 50 °C)
Option 01	10 MHz	$\pm 5 \times 10^{-9}$ /day	$\pm 3 \times 10^{-8}$ (0 to 50 °C)

(2) Instruments required for calibration

- Oscilloscope: 10 MHz, external trigger possible
- Frequency standard: Standard radio wave receiver or equipment having equivalent function (accuracy better than 1×10^{-9})

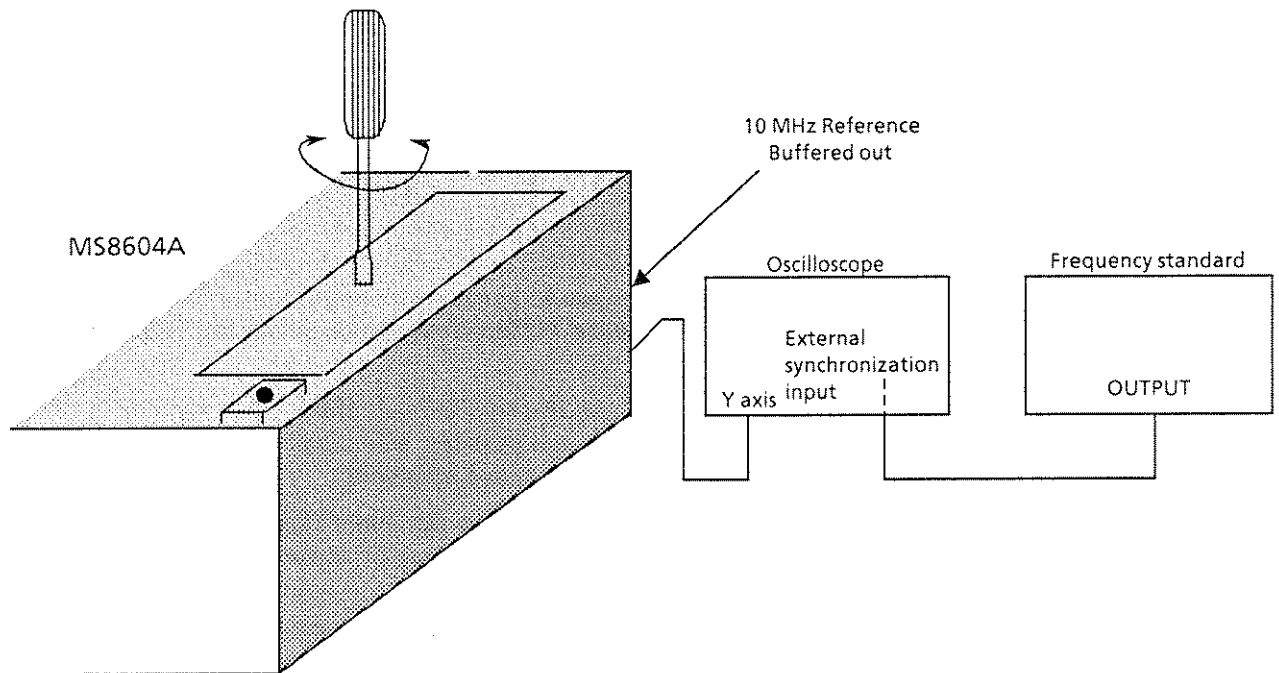
(3) Setup**Calibration of reference-crystal-oscillator frequency****(4) Precautions for Calibration**

Applying a standard 10 MHz signal to the oscilloscope Y-axis produces a lissajous waveform. Adjust the reference oscillator frequency so that the waveform becomes a stationary circularity at Step 6.

(5) Calibration procedure

Step	Procedure
1	Set-up the equipment as shown in the figure above. The ambient temperature should be $25^{\circ}\text{C} \pm 5^{\circ}\text{C}$
2	Allow the MS8604A reference crystal oscillator to warm-up for 24 hours by setting the Power switch on the front panel to the Stby position.
3	Then set the MS8604A Power switch to On.
4	Apply the standard frequency signal to the external synchronization input of the oscilloscope, and the signal output from the 10 MHz Reference Buffered out connector on the MS8604A rear panel to the Y axis.
5	Adjust the oscilloscope so that the input waveform can be observed. If the input waveform moves right or left on the screen and synchronization is not possible, this means that the frequency of the reference crystal oscillator does not match the standard frequency.
6	Loosen the screw on the reference-crystal-oscillator case at the upper right under the top cover. Then open the calibration-hole cover, and adjust the potentiometer in the hole so that the input waveform stops moving left or right on the oscilloscope screen.
7	After step 6, the crystal oscillator calibration hole is accessible. Adjust the trimmer in the calibration hole so that the input waveform does not shift horizontally on the oscilloscope screen.

SECTION 7 STORAGE AND TRANSPORTATION

This section describes the long-term storage, repacking and transportation of the MS8604A as well as the regular care procedures and the timing.

TABLE OF CONTENTS

7.1	Cleaning Cabinet	7-3
7.2	Storage Precautions	7-3
7.2.1	Precautions before storage	7-3
7.2.2	Recommended storage precautions	7-3
7.3	Repacking and Transportation	7-4
7.3.1	Repacking	7-4
7.3.2	Transportation	7-4

(Blank)

7.1 Cleaning Cabinet

Always turn the MS8604A power switch OFF and disconnect the power plug from the ac power inlet before cleaning the cabinet.

To clean the external cabinet:

- Use a soft, dry cloth for wiping off.
- Use a cloth moistened with diluted neutral cleaning liquid if the instrument is very dirty or before long-term storage. After insuring that the cabinet has been thoroughly dried, use a soft, dry cloth for wiping off.
- If loose screws are found, tighten them with the appropriate tools.

CAUTION

Never use benzene, thinner, or alcohol to clean the external cabinet; it may damage the coating, or cause deformation or discoloration.

7.2 Storage Precautions

This paragraph describes the precautions to take for long-term storage of the MS8604A.

7.2.1 Precautions before storage

- (1) Before storage, wipe dust, finger-marks, and other dirt off the MS8604A.
- (2) Avoid storing the MS8604A where:
 - 1) It may be exposed to direct sunlight or high dust levels.
 - 2) It may be exposed to high humidity.
 - 3) It may be exposed to active gases.
 - 4) It may be exposed to extreme temperatures ($< -40\text{ }^{\circ}\text{C}$ or $> 70\text{ }^{\circ}\text{C}$) or high humidity ($\geq 90\%$).

7.2.2 Recommended storage precautions

The recommended storage conditions are as follows:

- Temperature: 0 to 30 °C
- Humidity: 40 % to 80 %
- Stable temperature and humidity over 24-hour period

7.3 Repacking and Transportation

The following precautions should be taken if the MS8604A must be returned to Anritsu Corporation for servicing.

7.3.1 Repacking

Use the original packing materials. If the MS8604A is packed in other materials, observe the following packing procedure:

- (1) Wrap the MS8604A in a plastic sheet or similar material.
- (2) Use a cardboard, wooden box, or aluminum case which allows shock-absorbent material to be inserted on all sides of the equipment.
- (3) Use enough shock-absorbent material to protect the MS8604A from shock during transportation and to prevent it from moving in the container.
- (4) Secure the container with packing straps, adhesive tape or bands.

7.3.2 Transportation

Do not subject the MS8604A to severe vibration during transport. It should be transported under the storage conditions recommended in paragraph 7.2.

APPENDIX A SCREENS AND FUNCTIONS KEYS TRANSITION DIAGRAM

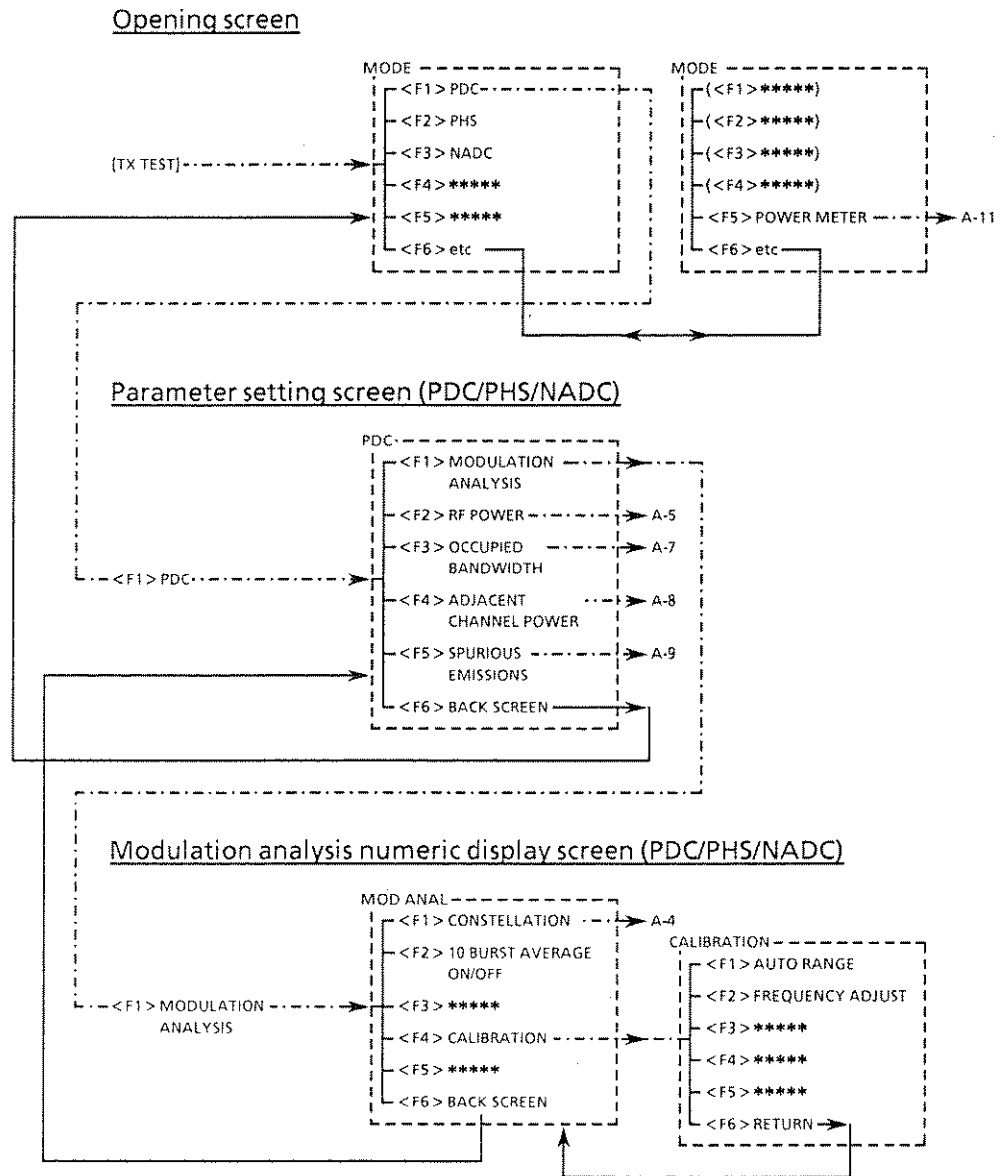

Constellation screen (PDC/PHS/NADC)

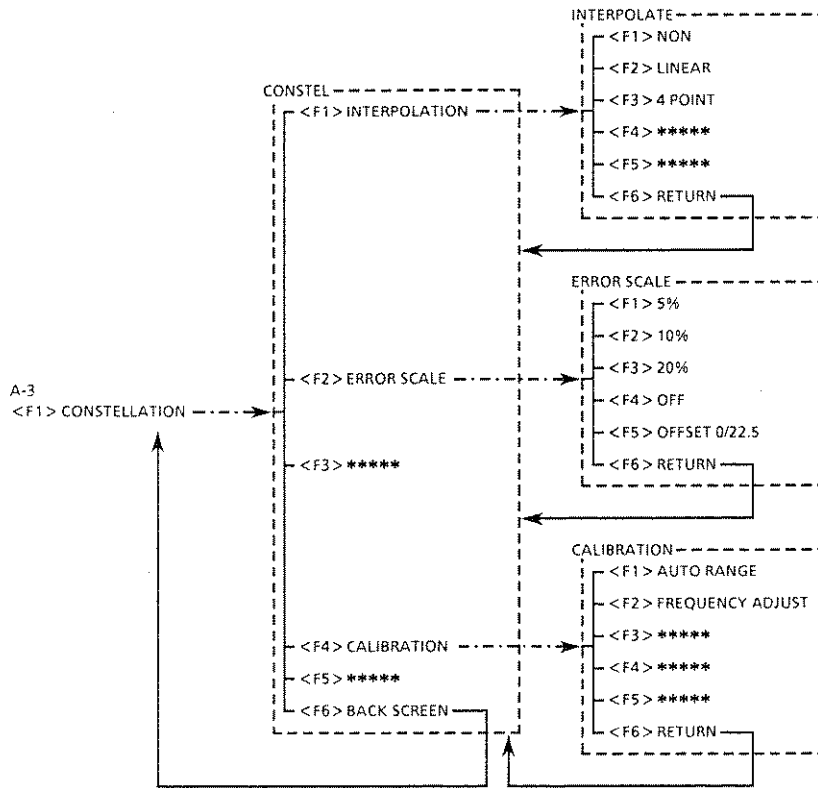

Power (burst amplitude) measurement screen (PDC/PHS/NADG)

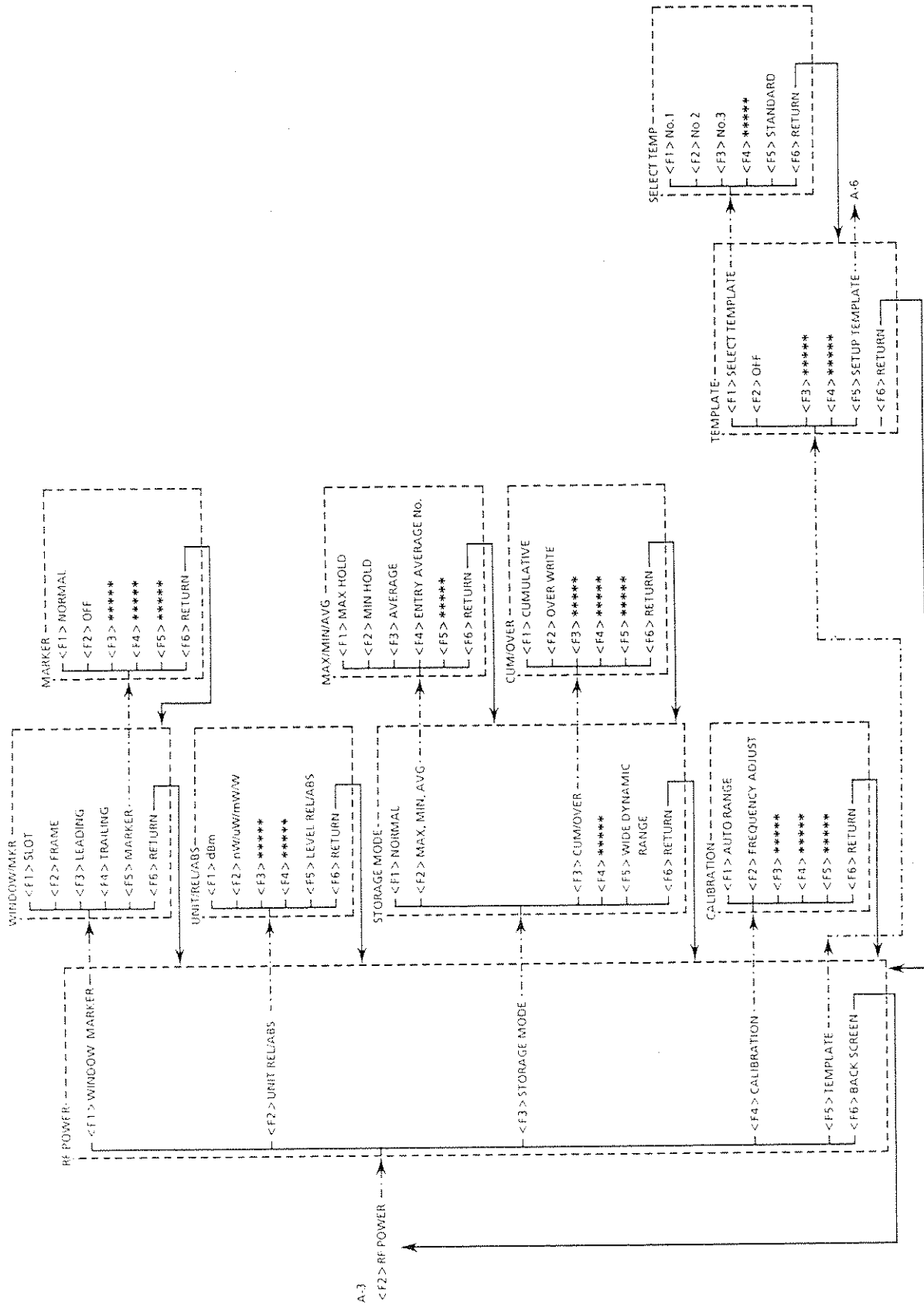

Template input screen (PDC/PHS/NADC)

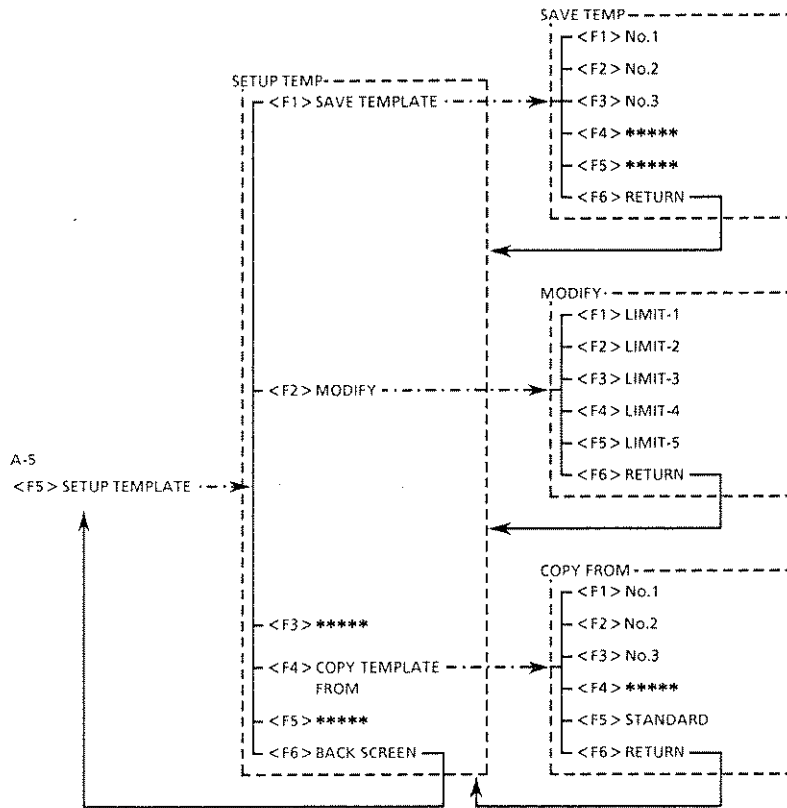

Occupied frequency bandwidth measurement screen (PDC/PHS)

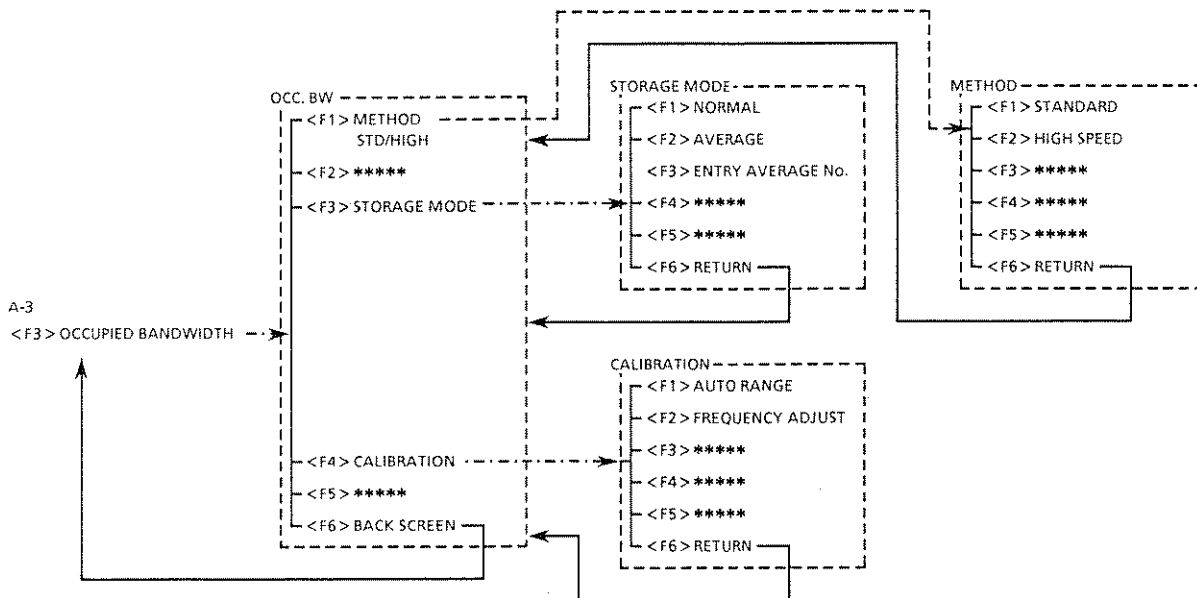

Occupied frequency bandwidth measurement screen (NADC)

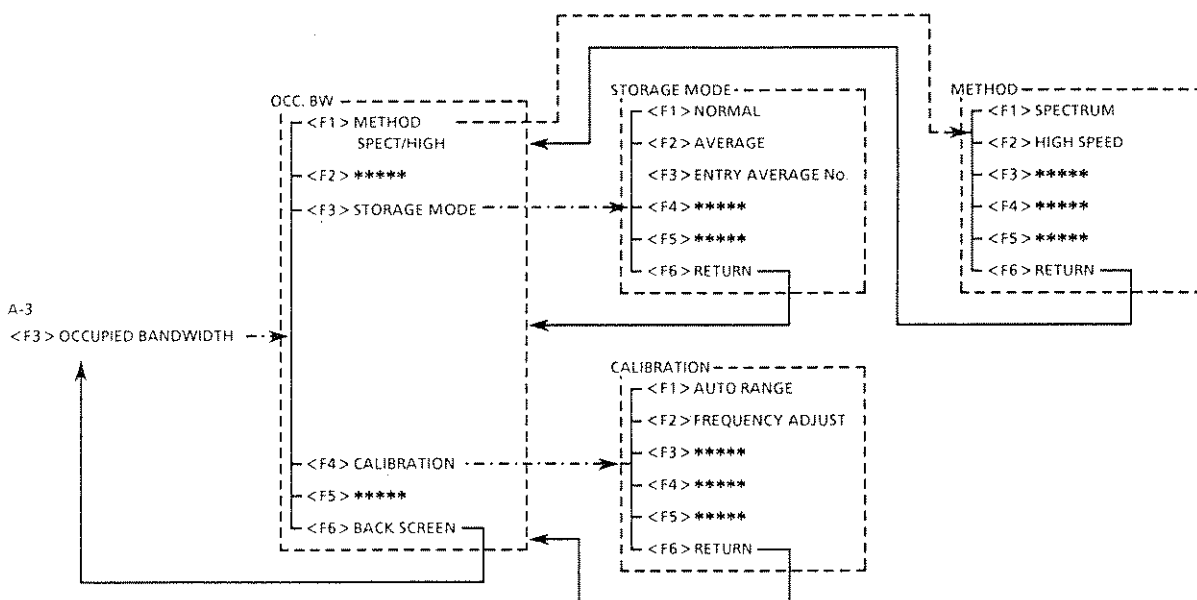

Adjacent channel leakage power measurement screen (PDC/PHS)

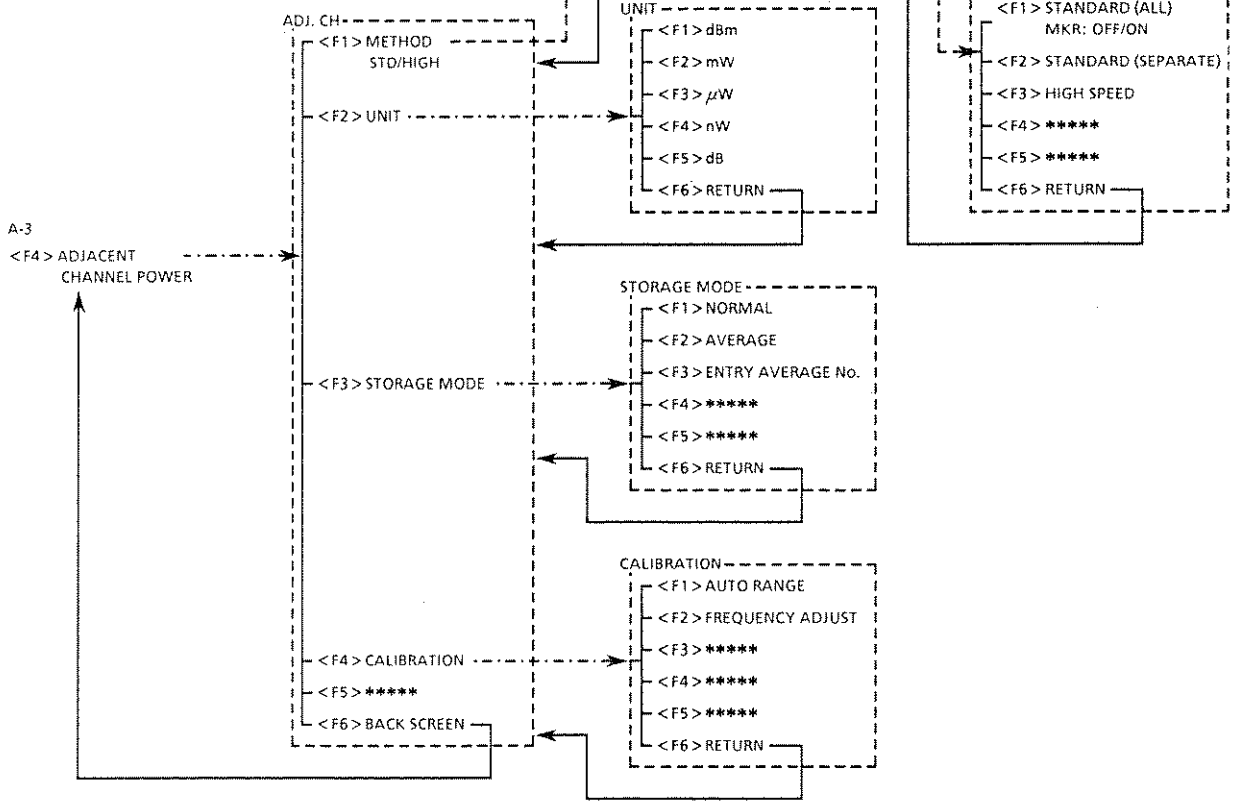

Adjacent channel leakage power measurement screen (NADC)

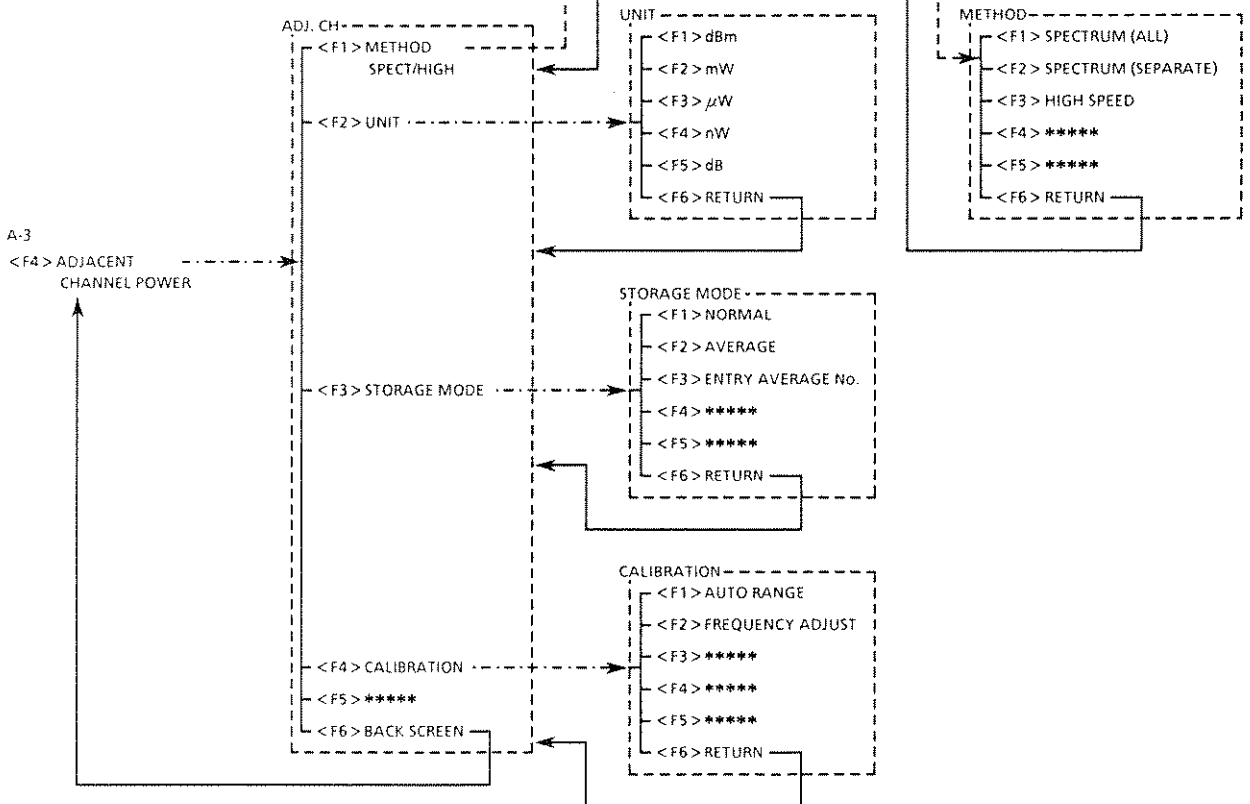

Spurious emissions measurement screen (PDC/PHS/NADC)

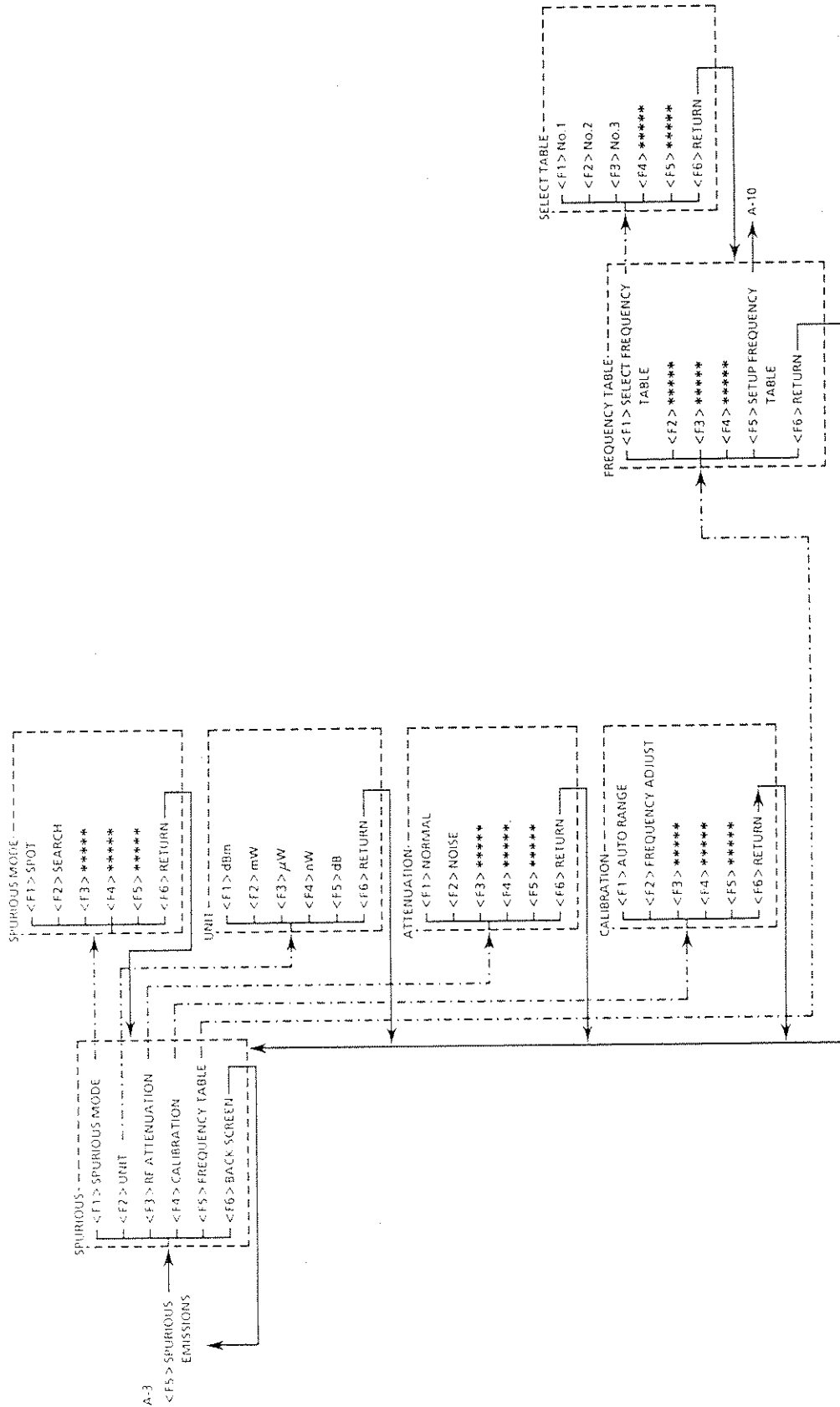

Spurious emissions frequency input screen (PDC/PHS/NADC)

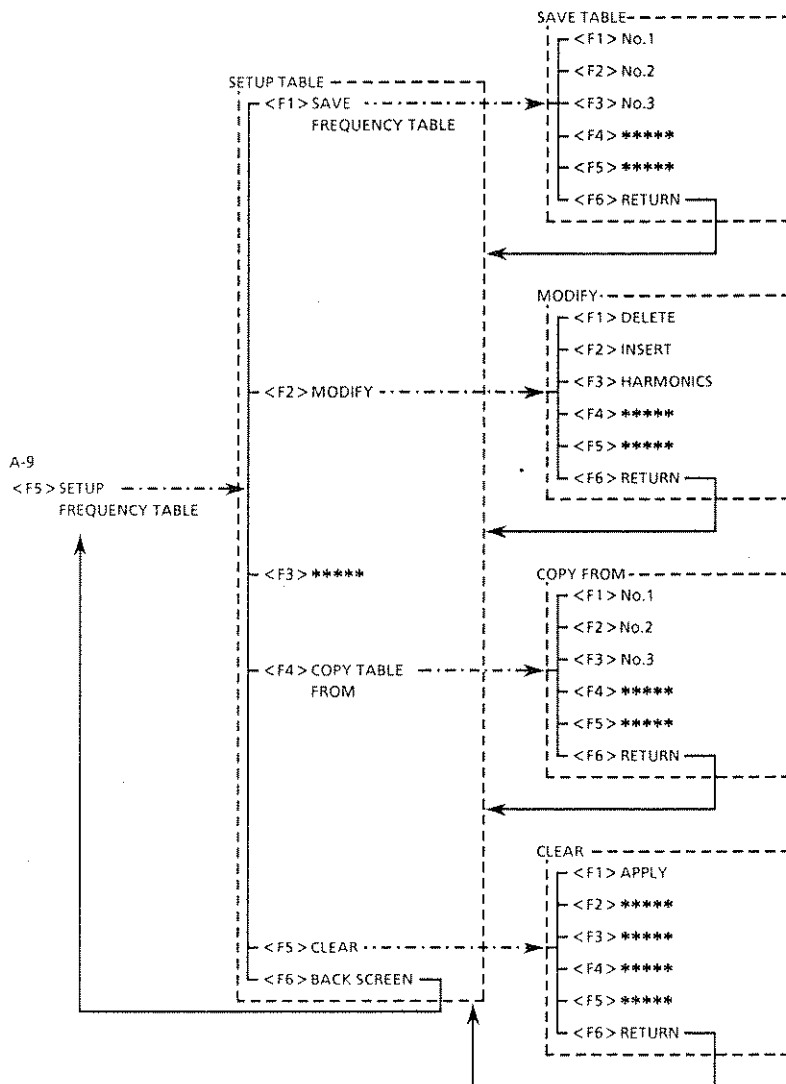

Power meter screen

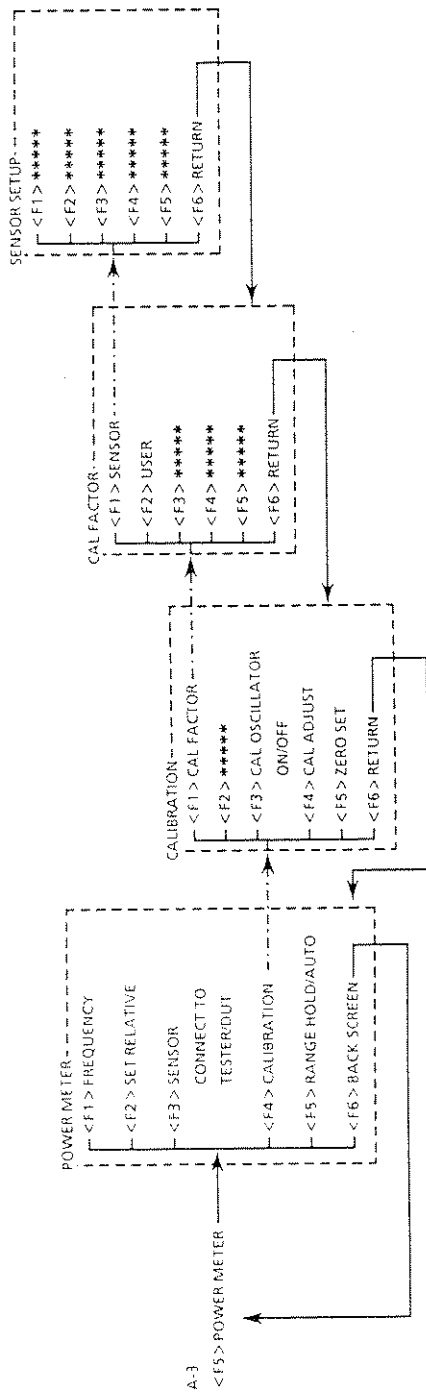

System Screen

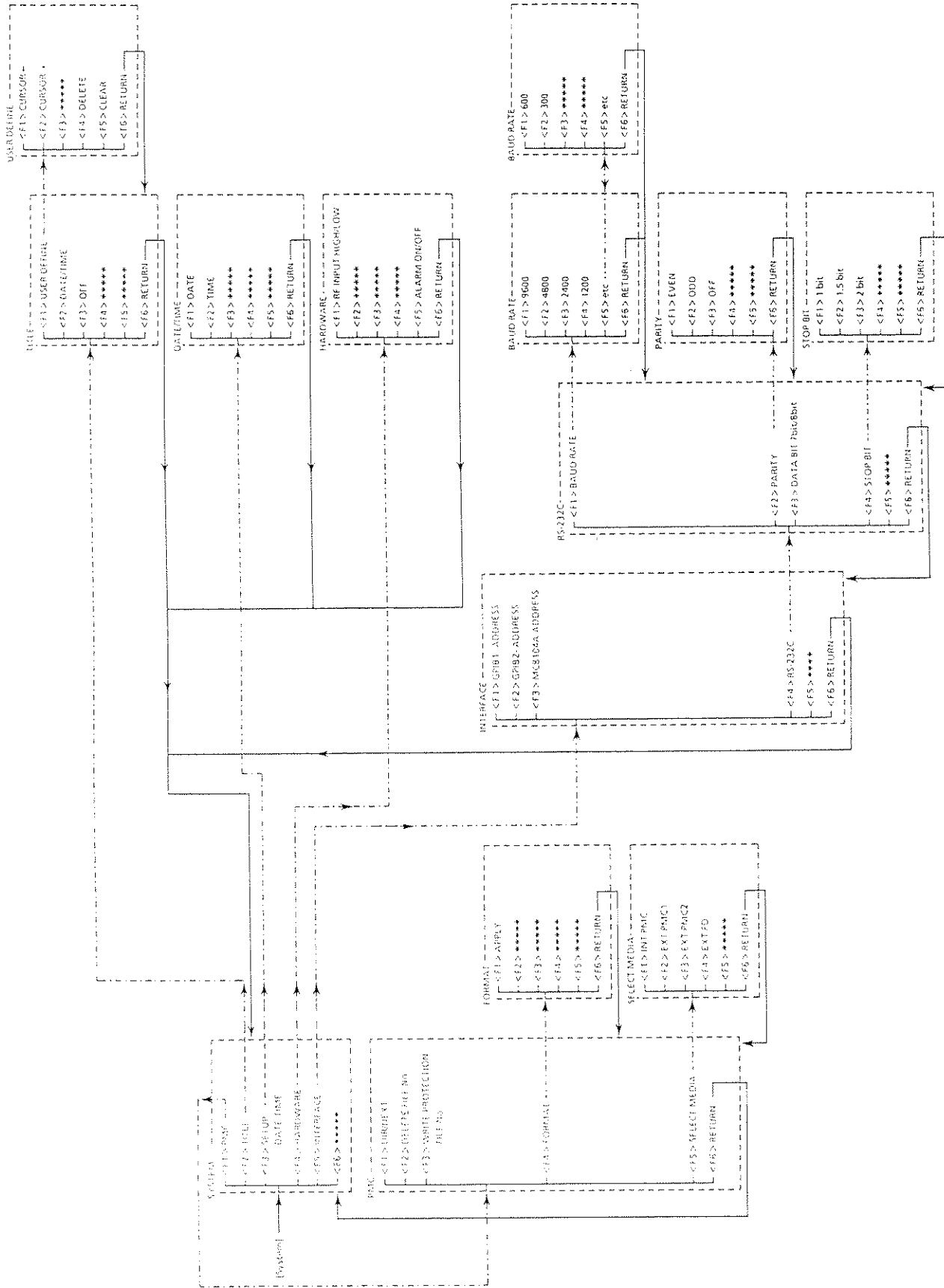

Copy control

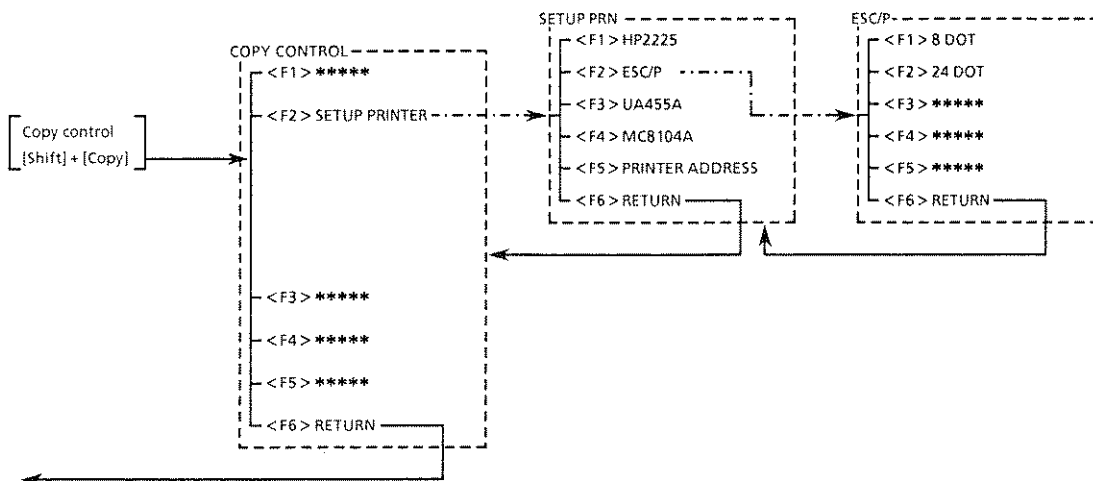

Recall

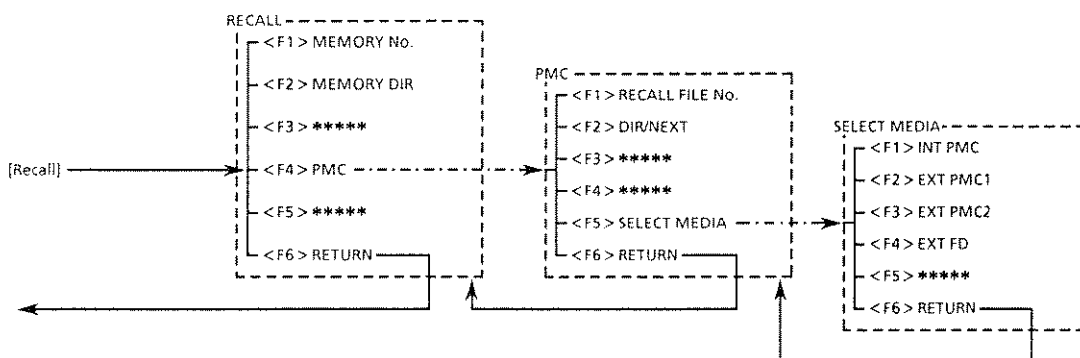

Save

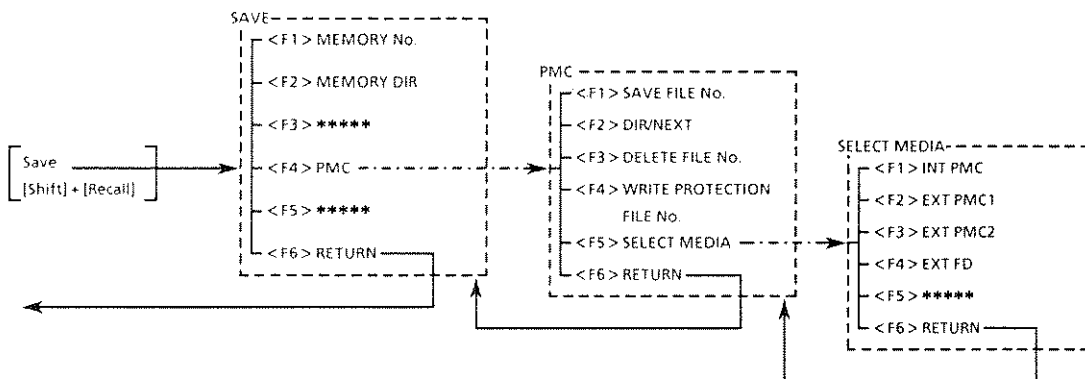

(Blank)

Frequency

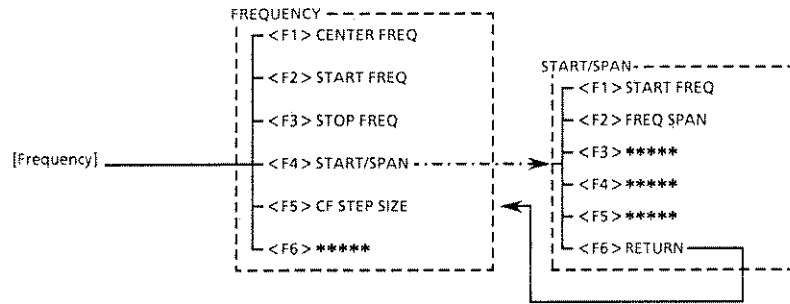

Span

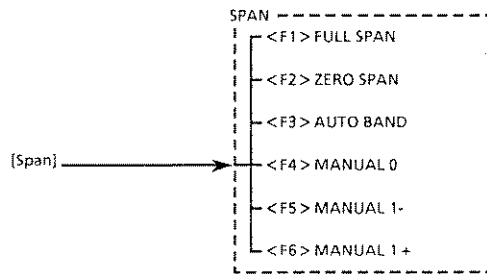

Amplitude

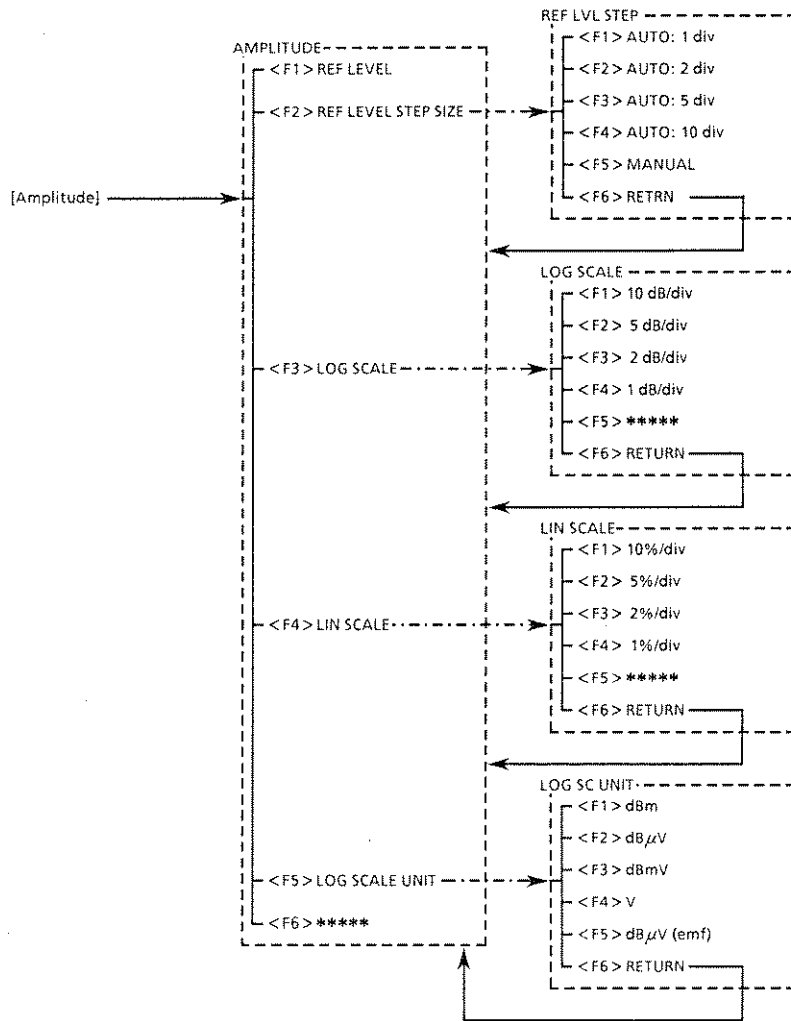

APPENDIX B INITIAL VALUES TABLES

- The initial values are the values set at the factory.
- Items indicated by the * are default values and are not displayed or selected.
- At the “Initial” field at the right end of the tables, items initialized by panel [Preset] key and GPIB command “PRE” “INI” command are indicated by “PS” and items initialized by GPIB “*RST” command are indicated by “PW”.
Items initialized by “PRE” “INI” command are also initialized by “*RST” command.
- Items which are not initialized by any command are indicated by “NO”.

Measurement mode

Item	Initial value	Initial
Measurement mode (transmitter tester) (Spectrum analyzer)	Single Continuous	PS
Main function	TX Test	PW

B.1 TX Test Mode

Parameter setup screen

(1) PDC

Item	Initial value	Initial
Measured signal terminal	RF	PW
Maximum input level	30 dBm	PW
Measuring object & physical channel	MS-COM	PW
Rising edge symbol position	2	PW
Number of analysis symbols	135	PW
Slot spacing	3 (FULL RATE)	PW
Channel No. and frequency	1001 CH = 940.025000 MHz	PW
Frequency spacing	25.000 kHz	PW
Sync word pattern	S1 = 785B4	PW
Sync word pattern (binary) *	PW
Sync word start position *	59	PW
Root-Nyquist filter	YES	PW
Symbol timing	0	PW

(2) PHS

Item	Initial value	Initial
Measured signal terminal	RF	PW
Maximum input level	30 dBm	PW
Measuring object & physical channel	PS-COM	PW
Rising edge symbol position	2	PW
Number of analysis symbols	110	PW
Channel No. and frequency	1001 CH = 1895.150000 MHz	PW
Frequency spacing	300.000 kHz	PW
Unique word pattern	16 bit = E149	PW
Unique word pattern (binary) *	PW
Unique word start position *	6	PW
Root-Nyquist filter	YES	PW
Symbol timing	0	PW

(3) NADC

Item	Initial value	Initial
Measured signal terminal	RF	PW
Maximum input level	30 dBm	PW
Measuring object & physical channel	MOBILE	PW
Rising edge symbol position	6	PW
Number of analysis symbols	156	PW
Slot spacing	3 (FULL RATE)	PW
Channel No. and frequency	1 CH = 825.030000 MHz	PW
Frequency spacing	30.000 kHz	PW
Sync word pattern	Sync1 = A91DE4A	PW
Sync word pattern (binary) *	PW
Sync word start position *	14	PW
Root-Nyquist filter	YES	PW
Symbol timing	0	PW

Modulation analysis numeric display screen

Item	Initial value	Initial
★ Soft key		
Average of 10 consecutive burst signals	F2 : OFF (alternate)	PS

Constellation display screen

Item	Initial value	Initial
★ Soft key		
Interpolation mode	F1 – F1 : NON	PS
Error circle display	F2 – F4 : OFF	PS
Error circle angle	F2 – F5 : 0 (alternate)	PS

Power measurement screens

(1) PDC

Item	Initial value	Initial
★ Screen display		
Physical channel	MS-COM	PW
Template selection	STANDARD	PW
Marker *	180 (CRT coordinates center) *1	PS
★ Soft keys		
Burst amplitude display method (WINDOW)	F1 - F1 : SLOT	PS
Marker	F1 - F5 - F2 : OFF	PS
Measured result display units	F2 - F2 : nW/ μ W/mW/W	PS
Vertical axis level	F2 - F5 : REL	PS
Storage mode	F3 - F1 : NORMAL	PS
Number of averaging	F3 - F2 - F4 : 4	PS
Template selection	F5 - F1 - F5 : STANDARD	PW

*1

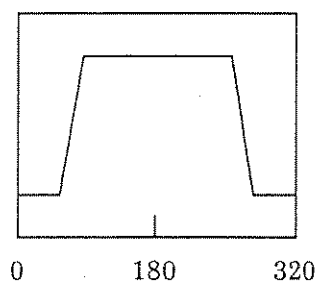

(2) PHS

Item	Initial value	Initial
★ Screen display		
Physical channel	PS-COM	PW
Template selection	STANDARD	PW
Marker *	180 (CRT coordinates center) *1	PS
★ Soft keys		
Burst amplitude display method (WINDOW)	F1-F1 : SLOT	PS
Marker	F1-F5-F2 : OFF	PS
Measured result display units	F2-F2 : nW/ μ W/mW/W	PS
Vertical axis level	F2-F5 : REL	PS
Storage mode	F3-F1 : NORMAL	PS
Number of averaging	F3-F2-F4 : 4	PS
Template selection	F5-F1-F5 : STANDARD	PW

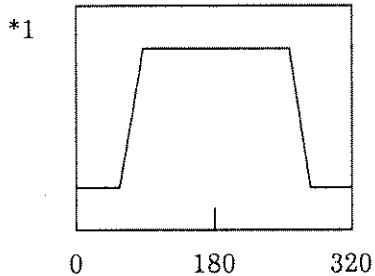

(3) NADC

Item	Initial value	Initial
★ Screen display		
Physical channel	MOBILE	PW
Template selection	STANDARD	PW
Marker *	180 *1	PS
★ Soft keys		
Burst amplitude display method (WINDOW)	F1 - F1 : SLOT	PS
Marker	F1 - F5 - F2 : OFF	PS
Measured result display units	F2 - F2 : nW/μW/mW/W	PS
Vertical axis level	F2 - F5 : REL	PS
Storage mode	F3 - F1 : NORMAL	PS
Number of averaging	F3 - F2 - F4 : 4	PS
Template selection	F5 - F1 - F5 : STANDARD	PW

*1

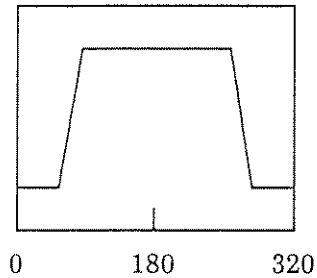

Template input screens

(1) PDC

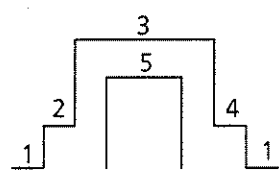
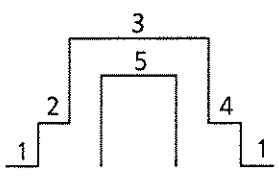
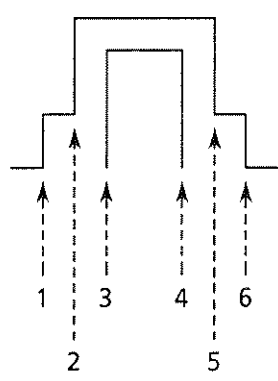
Item		Initial value	Initial
★ Screen display			
Physical channel		MS-COM	PW
Template selection		STANDARD	PW
★ Soft keys			
Standard line selection		F2 – F1 : LIMIT-1	PS
★ Template set value			
User-set pattern	(LIMIT-1) *	– 70 dB	NO
	(LIMIT-2)	– 60 dB	
	(LIMIT-3)	4 dB	
	(LIMIT-4)	– 60 dB	
	(LIMIT-5)	– 14 dB	
			
RCR-set pattern (fixed)	(LIMIT-1)	– 70 dB	NO
	(LIMIT-2)	– 60 dB	
	(LIMIT-3)	4 dB	
	(LIMIT-4)	– 60 dB	
	(LIMIT-5)	– 14 dB	
			
MS-COM symbol position (fixed)	1	– 2 symbol	NO
	2	– 0.5 symbol	
	3	2 symbol	
	4	137 symbol	
	5	139.5 symbol	
	6	141 symbol	
MS-CON symbol position (fixed)	1	– 2 symbol	NO
	2	– 0.5 symbol	
	3	2 symbol	
	4	131 symbol	
	5	133.5 symbol	
	6	135 symbol	
			

(2) PHS

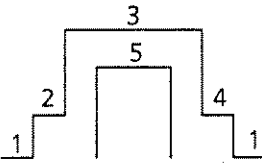
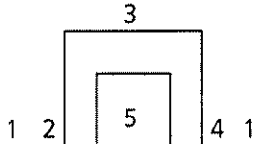
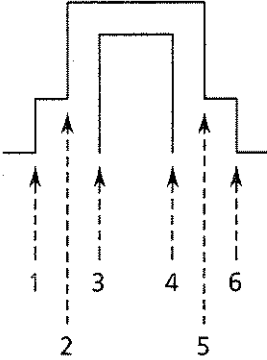
Item		Initial value	Initial
★ Screen display			
Physical channel		PS-COM	PW
Template selection		STANDARD	PW
★ Soft keys			
Standard line selection		F2-F1 : LIMIT-1	PS
★ Template set value			
User-set pattern	(LIMIT-1) *	-56 dB	NO
	(LIMIT-2)	-50 dB	
	(LIMIT-3)	4 dB	
	(LIMIT-4)	-50 dB	
	(LIMIT-5)	-14 dB	
			
RCR-set pattern (fixed)	(LIMIT-1)	-56 dB	NO
	(LIMIT-2)	-56 dB	
	(LIMIT-3)	4 dB	
	(LIMIT-4)	-56 dB	
	(LIMIT-5)	-14 dB	
			
Symbol position (fixed)	1	- 2 symbol	NO
	2	- 0.5 symbol	
	3	2 symbol	
	4	112 symbol	
	5	114.5 symbol	
	6	116 symbol	
			
/		/	/

(3) NADC

Item		Initial value	Initial
★ Screen display			
Physical channel		MOBILE	PW
Template selection		STANDARD	PW
★ Soft keys			
Standard line selection		F2-F1 : LIMIT-1	PS
★ Template set value			
User-set pattern	(LIMIT-1)	-60 dB	NO
	(LIMIT-2)	-50 dB	
	(LIMIT-3)	3 dB	
	(LIMIT-4)	-50 dB	
	(LIMIT-5)	-20 dB	
EIA/TIA setting (fixed)	(LIMIT-1)	-60 dB	NO
	(LIMIT-2)	-60 dB	
	(LIMIT-3)	3 dB	
	(LIMIT-4)	-60 dB	
	(LIMIT-5)	-20 dB	
MOBILE symbol position (fixed)	1	1 symbol	NO
	2	3 symbol	
	3	6 symbol	
	4	162 symbol	
	5	165 symbol	
	6	167 symbol	
SHORTENED symbol position (fixed)	1	1 symbol	NO
	2	3 symbol	
	3	6 symbol	
	4	140 symbol	
	5	143 symbol	
	6	145 symbol	

Occupied bandwidth measurement screen

Item	Initial value	Initial
★ Screen display		
Measurement method selection	HIGH SPEED	PS
★ Soft keys		
Measurement method selection	F1 – F2 : HIGH SPEED	PS
Storage mode	F3 – F1 : NORMAL	PS
Number of averaging	F3 – F3 : 4	PS

Adjacent channel leakage power measurement screen

Item	Initial value	Initial
★ Screen display		
Measurement method	HIGH SPEED	PS
★ Soft keys		
Measurement method selection	F1 – F3 : HIGH SPEED	PS
Measured result display units	F2 – F1 : dBm	PS
Storage mode	F3 – F1 : NORMAL	PS
Number of averaging	F3 – F3 : 4	PS

Spurious emissions measurement screens

(1) PDC

Item	Initial value	Initial
★ Screen display		
Frequency table No.	No. 1	PW
Measurement method	SPOT	PS
★ Soft keys		
Frequency table selection	F5 – F1 – F1 : No. 1	PW
Measurement method selection	F1 – F1 : SPOT	PS
Measured result display units	F2 – F1 : dBm	PS
Attenuation	F3 – F1 : NORMAL	PS
★ Frequency table set value		
User-set pattern (f1)	1880.050000 MHz	PW
(f2)	2820.075000 MHz	
(f3)	3760.100000 MHz	
(f4)	4700.125000 MHz	

(2) PHS

Item	Initial value	Initial
★ Screen display		
Frequency table No.	No. 1	PW
Measurement method	SPOT	PS
★ Soft keys		
Frequency table selection	F5 – F1 – F1 : No. 1	PW
Measurement method selection	F1 – F1 : SPOT	PS
Measured result display units	F2 – F1 : dBm	PS
Attenuation	F3 – F1 : NORMAL	PS
★ Frequency table set value		
User-set pattern (f1)	3790.300000 MHz	PW
(f2)	5685.450000 MHz	
(f3)	7580.600000 MHz	

(3) NADC

Item	Initial value	Initial
★ Screen display		
Frequency table No.	No. 1	PW
Measurement method	SPOT	PS
★ Soft keys		
Measurement method selection	F1 – F1 : SPOT	PS
Frequency table units	F5 – F1 – F1 : No. 1	PW
Measured result display units	F2 – F1 : dBm	PS
Attenuation	F3 – F1 : NORMAL	PS
★ Frequency table set value		
User-setting	(f1) 1650.060000 MHz (f2) 2475.090000 MHz (f3) 3300.120000 MHz (f4) 4125.150000 MHz (f5) 4950.180000 MHz (f6) 5775.210000 MHz (f7) 6600.240000 MHz (f8) 7425.270000 MHz (f9) 8250.300000 MHz	NO

Spurious emissions measurement frequency input screen

Item	Initial value	Initial
★ Screen display		
Frequency table No.	No. 1	PW
★ Frequency table set value		
User-set pattern (No. 1 to No. 3)	See the "Spurious emissions measurement screen" section.	NO

Power meter screen

Item	Initial value	Initial
★ Screen display		
Center calibration factor	0 dB	PW
User calibration factor	0 dB	PW
Reference calibration factor	0 dB	PW
Frequency	1000.000000 MHz	PW
★ Soft keys		
Power sensor connector	F3 : TESTER (alternate)	PW
Calibration factor	F4 – F1 – F1 : SENSOR	PW
Calibration oscillator	F4 – F3 : OFF (alternate)	PW
Range	F5 : AUTO (alternate)	PS

B.2 System Setup Screen

Item	Initial value	Initial
★ Screen display, soft keys		
Media selection state	INT PMC	PW
Title selection	DATE/TIME	PW
User-defined title *	(Blank)	PW
Alarm tone	ON	PW
GPIB1 address	1	PW
GPIB2 address	16	PW
MC8104A address	19	PW
Printer mode	HP2225	PW
● Serial port subgroup		
Baud rate *	2400	PW
Priority *	EVEN	PW
Data bits *	8 bit	PW
Stop bit *	1 bit	PW

B.3 Spectrum Mode

- Initial values prefixed with a # are the values when COUPLE (RBW/VBW/SWT) MODE is COMMON.

Group	Item	Initial value		Initial
		TRACE-FREQ	TRACE-TIME	
Frequency	Frequency bandwidth setting mode	START-STOP		PS
	Start frequency	0 Hz	-----	PS
	Center frequency	4.25 GHz		PS
	Stop frequency	8.50 GHz	-----	PS
	Frequency span	8.50 GHz	*0 Hz	PS
	Center frequency step size	1 GHz		PS
	Band selection	AUTO (0 to 8.5 GHz)		PS
Level	Reference level	+10 dBm		PS
	Reference level step size	AUTO : 1 div		PS
	Scale mode	LOG	LOG	PS
	LOG scale	10 dB/div	10 dB/div	PS
	LIN scale	10 %/div	10 %/div	PS
	LOG units	dBm		PW
Display mode	Waveform processing mode	NORMAL	NORMAL	PS
	Number of average processing	8 times		PS
	Detection method	PEAK	*SAMPLE	PS
	Delay time	-----	0 sec	PS
	Time span	-----	#200 msec	PS
	Expansion zone	-----	OFF	PS
	Expand	-----	OFF	PS
	Waveform monitor (ON/OFF)	-----	OFF	PS
	FM waveform monitor shift	-----	200 kHz/div	PS
	FM waveform monitor coupling	-----	AC COUPLING	PS

Group	Item	Initial value		Initial
		TRACE-FREQ	TRACE-TIME	
Marker function	Marker mode	NORMAL		PS
	Zone marker center position	250 point	250 point	PS
	Zone marker width	51 points	*1 point	PS
	Marker search mode	PEAK SEARCH		PS
	Multi marker mode	OFF		PS
	Multi marker list	OFF		PS
	Multi marker (No. 1 to No. 10) ON/OFF	No. 1 = ON, NO. 2 to 10 = OFF		PW
	Active marker No.	No. 1		PW
Sweep function	Sweep mode	CONTINUOUS		PS
	Zone sweep	OFF	-----	PS
	Tracking sweep	OFF	-----	PS
	Gate sweep	OFF		PS
	Gate delay time	0 sec		PS
	Gate width	1 msec		PS
	Gate zone end setting	INTERNAL		PS
	Trigger switch	FREE RUN		PS
	Trigger source	VIDEO		PS
	Trigger source (EXT)	Input 1		PS
	Trigger source (TV)	NTSC		PS
	Trigger source (TV SYNC)	V-SYNC		PS
	TV horizontal sync line No.	ODD 10		PS
	Trigger slope	RISE		PS
	Trigger level	0 %		PS
Waveform write/read	Trace write switch	ON		PS
	Trace read switch	ON		PS

Group	Initial	Initial value		Initial
		TRACE-FREQ	TRACE-TIME	
RBW/ VBW/ SWT/ ATTEN	Resolution bandwidth RBW	AUTO		PS
	Video bandwidth VBW	AUTO		PS
	Sweep time SWT	AUTO		PS
	RF attenuator ATTEN	AUTO		PS
	VBW/RBW ratio when VBW = AUTO	1		PS
Sound monitor	Sound monitor mode (AM/FM)	OFF		PS
	Sound monitor volume	10		PS
System setting	Number of data points	501 points		NO
	Frequency/time domain RBW/VBW/SWT	COMMON		NO
Calibration	Preselector switch	ON		NO
	Preselector Peaking bias	0		NO
CAL/UNICAL	RBW/VBW/SWT abnormal display	Initialized to "ON" when the power is turned on.		NO
Spectrum data/terminator	Response data (ASCII/BINARY)	ASCII		NO
	Terminator (LF/CR + LF)	LF		NO

(Blank)

APPENDIX C ERROR MESSAGES

There are the following two kinds of error messages:

- Measurement error messages Reverse displayed on the third line from the top left of the screen.
- Data input error messages Reversed displayed in the communication area at the bottom of the screen.

1. Measurement error messages

There are five main measurement error messages as follows. They are shown in high priority order.

INPUT LEVEL OVER	RF input level exceeded the hard limit.
LEVEL OVER	Level too high.
LEVEL UNDER	Level too low.
SIGNAL ABNORMAL	Measurement impossible
SYNC (or UNIQUE) WORD NOT FOUND	Sync word cannot be detected.

There are also the following two messages:

POWER SENSOR ABNORMAL	Power sensor abnormal (power meter screen only)
SET FREQUENCY TABLE	Spurious emissions measurement frequency not input. (Spurious emissions measurement screen only)

2. Data input error messages

In the "Class" column, "S" indicates that the error message is used in Spectrum mode and "T" indicates that the error message is used in TX Test mode.

Contents	Displayed character string	Class
GPIB command is not defined.	300 Undefined command	S, T
GPIB command numeric data is invalid.	301 Invalid numeric data	S, T
GPIB command unit is invalid.	302 Invalid unit	S, T
GPIB data is insufficient.	303 Insufficient data	S, T
GPIB command character string data is invalid.	304 Invalid string data	S, T
GPIB command character string is too long.	305 String too long	S, T
Time out error.	400 Time out ERROR	S, T
MS8604A is not a system controller.	401 Not in system controller mode	S, T
MS8604A is not a device.	402 Not in device mode	S, T
Input buffer is full.	403 Input buffer full	S, T
Listener device is not connected.	404 Listener device not connected	S, T
Other GPIB error.	410 Other GPIB ERROR	S, T
Media is write-protected.	450 Media write protected	S, T
Media is not installed.	451 Media not installed	S, T
Memory capacity is too small.	452 Insufficient memory	S, T
File does not exist.	453 File not found	S, T
Read/write error.	454 Read/write ERROR	S, T
Memory type is incorrect.	455 Memory type is different	S, T
Media is not formatted.	456 Media not formatted	S, T
Other Media error.	460 Other Media ERROR	S, T

Contents	Displayed character string	Class
Out of range General	500 Out of range	S, T
Out of range 100 Hz to 8.5 G	500 Range limits : 100 Hz - 8.5 GHz	S
Out of range 100 Hz to 2.0 GHz	500 Range limits : 100 Hz - 2.0 GHz	S
Out of range 1.7 GHz to 7.5 GHz	500 Range limits : 1.7 GHz - 7.5 GHz	S
Out of range 6.5 GHz to 8.5 GHz	500 Range limits : 6.5 GHz - 8.5 GHz	S
Out of range \cong 8.6 GHz	500 Range limits : \cong 8.6 GHz	S
Out of range \cong 2.1 GHz	500 Range limits : \cong 2.1 GHz	S
Out of range \cong 5.8 GHz	500 Range limits : \cong 5.8 GHz	S
Out of range \cong 2.0 GHz	500 Range limits : \cong 2.0 GHz	S
Out of range 1 Hz to 8.5 GHz	500 Range limits : 1 Hz - 8.5 GHz	S
Out of range 10 Hz to 3 MHz	500 Range limits : 10 Hz - 3 MHz	S
Out of range 1 Hz to 3 MHz	500 Range limits : 1 Hz - 3 MHz	S
Out of range 10 Hz to 9.99999 MHz	500 Range limits : 10 Hz - 9.99999 MHz	S
Out of range \cong 50 kHz	500 Range limits : \cong 50 kHz	S
Out of range 1 Hz to 1 MHz	500 Range limits : 1 Hz - 1 MHz	T
Out of range 100 Hz to 8.5 GHz	500 Range limits : 100 Hz - 8.5 GHz	T
Out of range -1000 s to 1000 s	500 Range limits : -1000 s - 1000 s	S
Out of range 20 ms to 1000 s	500 Range limits : 20 ms - 1000 s	S
Out of range 100 μ s to 1000 s	500 Range limits : 100 μ s - 1000 s	S
Out of range 50 μ s to 1000 s	500 Range limits : 50 μ s - 1000 s	S
Out of range 0 s to 1000 s	500 Range limits : 0 s - 1000 s	S
Out of range 20 μ s to 65.5 ms	500 Range limits : 20 μ s - 65.5 ms	S
Out of range 0 s to 65.5 ms	500 Range limits : 0 s - 65.5 ms	S
Out of range 20 dB to 75 dB (AUTO)	500 Range limits : 20 dB - 75 dB (AUTO)	S
Out of range 1 dB to 100 dB	500 Range limits : 1 dB - 100 dB	S
Out of range -100 dB to 100 dB	500 Range limits : -100 dB - 100 dB	S
Out of range 0.1 dB to 100 dB	500 Range limits : 0.1 dB - 100 dB	S
Out of range -200 dB to 200 dB	500 Range limits : -200 dB - 200 dB	S
Out of range -100 dBm to 30 dBm (AUTO)	500 Range limits : -100 dBm - 30 dBm (AUTO)	S
Out of range -100 dB to 30 dB	500 Range limits : -100 dB - 30 dB	S
Out of range -100 % to 100 %	500 Range limits : -100 % - 100 %	S
Out of range 1 % to 99 %	500 Range limits : 1 % - 99 %	S
Out of range -10 V to 10 V	500 Range limits : -10 V - 10 V	S
Out of range 0 to 30	500 Range limits : 0 - 30	S, T
Out of range 1 to 8	500 Range limits : 1 - 8	S
Out of range 1 to 99	500 Range limits : 1 - 99	S
Out of range 0 to 500	500 Range limits : 0 - 500	S
Out of range 2 to 256	500 Range limits : 2 - 256	S
Out of range -128 to 127	500 Range limits : -128 - 127	S
Out of range 0 to 20	500 Range limits : 0 - 20	S
Out of range 9 to 262	500 Range limits : 9 - 262	S
Out of range 10 to 263	500 Range limits : 10 - 263	S
Out of range 5 to 310	500 Range limits : 5 - 310	S
Out of range 6 to 310	500 Range limits : 6 - 310	S

Contents	Displayed character string	Class
Out of range 0.0001 to 100	500 Range limits : 0.0001 - 100	S
Out of range 1 to 10	500 Range limits : 1 - 10	S
Out of range 1 to 501	500 Range limits : 1 - 501	S
Out of range 2 to 99	500 Range limits : 2 - 99	T
Out of range 1 to 4	500 Range limits : 1 - 4	S, T
Out of range 101 to 199	500 Range limits : 101 - 199	T
Out of range Date	500 Set date : yy mm dd	T
Out of range Time	500 Set time : hh mm ss	T
Out of range -4 dBm to 40 dBm	500 Range limits : -4 dBm - 40 dBm	T
Out of range -110 dB to 10 dB	500 Range limits : -110.0 dB - 10.0 dB	T
Out of range -10 dB to 10 dB	500 Range limits : -10.0 dB - 10.0 dB	T
Out of range -30 dB to 30 dB	500 Range limits : -30.0 dB - 30.0 dB	T
Execution prohibited.General	501 Command not available	S
Prohibited in TRACE-TIME mode.	501 Not available in TRACE-TIME	S
Prohibited in TRACE-TIME (EXPAND) mode.	501 Not available in time expanding	S
Prohibited in FREQ DOMAIN mode.	501 Not available in FREQ DOMAIN	S
Prohibited in TIME DOMAIN mode.	501 Not available in TIME DOMAIN	S
Valid only in CENTER-SPAN mode.	501 Available only CF-SP mode	S
Set RLV \geq -80 dBm.	501 Set REF LEVEL \geq -80 dBm	S
Prohibited when ZONE SWEEP=ON.	501 Not available in ZONE SWP : ON	S
Prohibited when GATE SWEEP=ON.	501 Not available in GATE SWP : ON	S
Prohibited when TRACING=ON.	501 Not available in SIGNAL TRACK : ON	S
Prohibited when FM/TRIG MONITOR=ON.	501 Not available in FM/TRIG MONITOR : ON	S
Prohibited when MARKER MODE=OFF.	501 Not available in MKR : OFF	S
Effective only when MARKER MODE=NORMAL.	501 Available only in MKR : NORMAL	S
Effective only when MARKER MODE=DELTA.	501 Available only in MKR : DELTA	S
Prohibited when MULTI MKR=OFF.	501 Not available in MULTI MKR : OFF	S
Prohibited when MULTI MKR=ON.	501 Not available in MULTI MKR : ON	S
Prohibited when SCALE=LIN.	501 Not available in SCALE : LIN	S
Prohibited when SCALE=LOG.	501 Not available in SCALE : LOG	S
Prohibited in FREE RUN mode.	501 Not available in FREE RUN	S
Prohibited in TRIGGERED mode.	501 Not available in TRIGGERED	S
Prohibited when EXPAND : ON.	501 Expanding not available	S
Prohibited in this BAND.	501 Not available in this BAND	S
Prohibited in CUM or OVER mode.	501 Not available in CUM or OVER	S
Set GATE and EXPAND to OFF.	501 Set GATE : OFF & time expanding : OFF	S
Set span to 500 MHz or less.	501 Set FREQ SPAN \leq 500 MHz	S
Prohibited when EXPAND MODE=OFF.	501 Not available in EXPAND MODE : OFF	S
Prohibited when EXPAND=OFF.	501 Not available in EXPAND : OFF	S

Contents		Displayed character string	Class
Set span to 100 kHz or greater.	501	Set FREQ SPAN \geq 100 kHz	S
Prohibited when MULTI MKR LIST = ON.	501	Not available in MULTI MKR LIST : ON	S
Prohibited with PDC specification.	501	Not available in PDC	T
Prohibited with PHS specification.	501	Not available in PHS	T
Cannot be executed when measured signal terminal is I, Q-AC/I, or Q-DC.	501	Not available in Terminal : I, Q-AC or I, Q-DC	T
Cannot be executed when MEASURING OBJECT is CONTINUOUS.	501	Not available in Measuring object : CONTINUOUS	T
Can be executed only when MEASURING OBJECT is MS-COM/MS-CONT.	501	Available only in Measuring object : MS-COM or MS-CONT	T
Cannot be executed when MEASURING OBJECT is BS.	501	Not available in Measuring object : BS	T
Cannot be executed when frequency is under 10 MHz.	501	Set Frequency \geq 10 MHz	T
Cannot be executed when SYNC WORD Pattern is USER.	501	Not available in SYNC WORD Pattern : USER	T
Cannot be executed when UNIQUE WORD Pattern is USER.	501	Not available in UNIQUE WORD Pattern : USER	T
Cannot be executed when SYNC WORD Pattern is NO.	501	Not available in SYNC WORD Pattern : NO	T
Cannot be executed when UNIQUE WORD Pattern is NO.	501	Not available in UNIQUE WORD Pattern : NO	T
Cannot be executed when vertical axis level is ABS.	501	Not available in LEVEL : ABS	T
Cannot be executed when TEMPLATE : OFF.	501	Not available in TEMPLATE : OFF	T
Cannot be executed when STORAGE MODE is AVERAGE.	501	Not available in STORAGE MODE : AVERAGE	T
Cannot be executed when STORAGE MODE is WIDE DYNAMIC RANGE.	501	Not available in STORAGE MODE : WIDE DYNAMIC RANGE	T
Cannot be executed when RS-232C is not installed.	501	RS-232C not installed	T
Execution error	502	Execution ERROR	S, T
Data does not exist.	502	Data not found	S, T
Count error	502	Count ERROR	S, T
Overflow/underflow	502	Data overflow/underflow	S, T
Set condition is invalid.	503	Invalid setup condition	S, T
Hardware error	504	Hardware ERROR	S, T
CAL signal error	504	Calibration signal ERROR	S, T
Other error	510	Other ERROR	S, T

Contents	Displayed character string	Class
DET MODE was changed to POS.	W600 Detector changed to Positive Peak	S
REF LEVEL value was changed.	W601 REF LEVEL changed	S
Measurement mode was changed from CONTINUOUS to SINGLE.	W602 Measure changed to SINGLE	T
Measurement method was changed from STANDARD to HIGH SPEED.	W603 Method changed to HIGH SPEED	T
Template display is cleared when vertical level is ABS.	W604 Not display TEMPLATE in LEVEL : ABS	T
Same as GPIB 1 MY ADDRESS.	W610 Same as MS8604 GPIB1' S ADDRESS	S, T
Same as GPIB 2 MY ADDRESS.	W610 Same as MS8604 GPIB2' S ADDRESS	S, T
Same as PRINTER ADDRESS.	W610 Same as PRINTER' S ADDRESS	S, T
Same as MC8104A ADDRESS.	W610 Same as MC8104' S ADDRESS	S, T

APPENDIX D CONNECTION TO UA-455A VIDEO PLOTTER

When connecting the MS8604A to a UA-455A Video Plotter and making a hard copy of the screen, select the connection cable and set the UA-455A rear panel switches and variable resistors as described below.

■ Connection cable

Use a DIN-8P cable (1 m) as the connection cable. This cable is supplied with the UA-455A as standard.

■ Switches and variable resistors

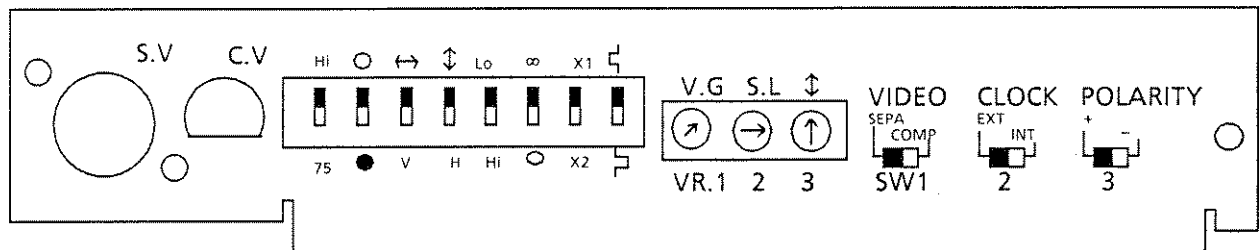

CAUTION

Before turning on the power to the UA-455A, check that the AC line voltage is the rated value (100 Vac +10 % or -15 %). If the AC voltage is unsuitable, abnormal voltage may damage the interior of the instrument.

- Notes:
- Set the switches to the black position.
 - Set the variable resistors to the average position.
 - For a detailed description of adjustment, refer to the UA-455A manual.

(Blank)



