

# Spectrum Master

MS2722C, MS2723C, MS2724C, MS2725C and MS2726C

High Performance Handheld Spectrum Analyzer



## User Guide

# Spectrum Master™ MS2722C, MS2723C, MS2724C, MS2725C and MS2726C

## High Performance Handheld Spectrum Analyzer

---

Appendix A provides a list of supplemental documentation for the Spectrum Master features and options. The additional documentation is available as PDF files on the Documentation disc or the Anritsu web site.

---

The Anritsu logo is displayed in a bold, sans-serif font. The letter 'A' is stylized with a diagonal slash through it.

## **WARRANTY**

The Anritsu product(s) listed on the title page is (are) warranted against defects in materials and workmanship for one year from the date of shipment.

Anritsu's obligation covers repairing or replacing products which prove to be defective during the warranty period. Buyers shall prepay transportation charges for equipment returned to Anritsu for warranty repairs. Obligation is limited to the original purchaser. Anritsu is not liable for consequential damages.

## **LIMITATION OF WARRANTY**

The foregoing warranty does not apply to Anritsu connectors that have failed due to normal wear. Also, the warranty does not apply to defects resulting from improper or inadequate maintenance by the Buyer, unauthorized modification or misuse, or operation outside of the environmental specifications of the product. No other warranty is expressed or implied, and the remedies provided herein are the Buyer's sole and exclusive remedies.

## **DISCLAIMER OF WARRANTY**

DISCLAIMER OF WARRANTIES. TO THE MAXIMUM EXTENT PERMITTED BY APPLICABLE LAW, ANRITSU COMPANY AND ITS SUPPLIERS DISCLAIM ALL WARRANTIES, EITHER EXPRESS OR IMPLIED, INCLUDING, BUT NOT LIMITED TO, IMPLIED WARRANTIES OF MERCHANTABILITY AND FITNESS FOR A PARTICULAR PURPOSE, WITH REGARD TO THE SOFTWARE PRODUCT. THE USER ASSUMES THE ENTIRE RISK OF USING THE PROGRAM. ANY LIABILITY OF PROVIDER OR MANUFACTURER WILL BE LIMITED EXCLUSIVELY TO PRODUCT REPLACEMENT.

NO LIABILITY FOR CONSEQUENTIAL DAMAGES. TO THE MAXIMUM EXTENT PERMITTED BY APPLICABLE LAW, IN NO EVENT SHALL ANRITSU COMPANY OR ITS SUPPLIERS BE LIABLE FOR ANY SPECIAL, INCIDENTAL, INDIRECT, OR CONSEQUENTIAL DAMAGES WHATSOEVER (INCLUDING, WITHOUT LIMITATION, DAMAGES FOR LOSS OF BUSINESS PROFITS, BUSINESS INTERRUPTION, LOSS OF BUSINESS INFORMATION, OR ANY OTHER PECUNIARY LOSS) ARISING OUT OF THE USE OF OR INABILITY TO USE THE SOFTWARE PRODUCTS, EVEN IF ANRITSU COMPANY HAS BEEN ADVISED OF THE POSSIBILITY OF SUCH DAMAGES. BECAUSE SOME STATES AND JURISDICTIONS DO NOT ALLOW THE EXCLUSION OR LIMITATION OF LIABILITY FOR CONSEQUENTIAL OR INCIDENTAL DAMAGES, THE ABOVE LIMITATION MAY NOT APPLY TO YOU.

## **TRADEMARK ACKNOWLEDGMENTS**

Windows, Windows 2000, and Windows XP, are all registered trademarks of Microsoft Corporation.

Acrobat Reader is a registered trademark of Adobe Corporation.

VxWorks and WindML are registered trademarks of Wind River Systems, Inc.

NI is a trademark of the National Instruments Corporation.

Spectrum Master is a trademark of Anritsu Company.

## **NOTICE**

Anritsu Company has prepared this manual for use by Anritsu Company personnel and customers as a guide for the proper installation, operation and maintenance of Anritsu Company equipment and computer programs. The drawings, specifications, and information contained herein are the property of Anritsu Company, and any unauthorized use or disclosure of these drawings, specifications, and information is prohibited; they shall not be reproduced, copied, or used in whole or in part as the basis for manufacture or sale of the equipment or software programs without the prior written consent of Anritsu Company.

## **UPDATES**

Updates, if any, can be downloaded from the Documents area of the Anritsu web site at:

<http://www.anritsu.com>

# **DECLARATION OF CONFORMITY**

**Manufacturer's Name:** ANRITSU COMPANY

**Manufacturer's Address:** Microwave Measurements Division  
490 Jarvis Drive  
Morgan Hill, CA 95037-2809  
USA

declares that the product specified below:

**Product Name:** Spectrum Master

**Model Numbers:** MS2722C, MS2723C, MS2724C, MS2725C, MS2726C

conforms to the requirement of:

EMC Directive: 2004/108/EC  
Low Voltage Directive: 2006/95/EC

## **Electromagnetic Compatibility: EN61326:2006**

Emissions: EN55011: 2007 Group 1 Class A

Immunity:	EN 61000-4-2:1995 +A1:1998 +A2:2001	4 kV CD, 8 kV AD
	EN 61000-4-3:2006 +A1:2008	3 V/m
	EN 61000-4-4:2004	0.5 kV S-L, 1 kV P-L
	EN 61000-4-5:2006	0.5 kV L-L, 1 kV L-E
	EN 61000-4-6: 2007	3 V
	EN 61000-4-11: 2004	100% @ 20 ms

## **Electrical Safety Requirement:**

Product Safety: EN 61010-1:2001

Morgan Hill, CA

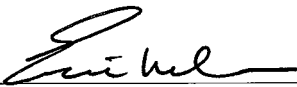
  
Eric McLean, Corporate Quality Director

6 Aug 2010

Date

European Contact: For Anritsu product EMC & LVD information, contact Anritsu LTD, Rutherford Close, Stevenage Herts, SG1 2EF UK, (FAX 44-1438-740202)

## CE Conformity Marking

Anritsu affixes the CE Conformity marking onto its conforming products in accordance with Council Directives of The Council Of The European Communities in order to indicate that these products conform to the EMC and LVD directive of the European Union (EU).



## C-tick Conformity Marking

Anritsu affixes the C-tick marking onto its conforming products in accordance with the electromagnetic compliance regulations of Australia and New Zealand in order to indicate that these products conform to the EMC regulations of Australia and New Zealand.



## Notes On Export Management

This product and its manuals may require an Export License or approval by the government of the product country of origin for re-export from your country.

Before you export this product or any of its manuals, please contact Anritsu Company to confirm whether or not these items are export-controlled.

When disposing of export-controlled items, the products and manuals need to be broken or shredded to such a degree that they cannot be unlawfully used for military purposes.

VxWorks Runtime  
License 2000-1189



WindML Target License  
2000-1372



NI Device License  
3-2000-1486



WindRiver USB Runtime License  
2000-1421



产品中有毒有害物质或元素的名称及含量

For Chinese Customers Only NLYB

部件名称	有毒有害物质或元素					
	铅 (Pb)	汞 (Hg)	镉 (Cd)	六价铬 [Cr(VI)]	多溴联苯 (PBB)	多溴二苯醚 (PBDE)
印刷线路板 (PCA)	×	○	×	×	○	○
机壳、支架 (Chassis)	×	○	×	×	○	○
其他(电缆、风扇、 连接器等) (Appended goods)	×	○	×	×	○	○

○：表示该有毒有害物质在该部件所有均质材料中的含量均在 SJ/T11363-2006 标准规定的限量要求以下。  
 ×：表示该有毒有害物质至少在该部件的某一均质材料中的含量超出 SJ/T11363-2006 标准规定的限量要求。

环保使用期限



这个标记是根据 2006/2/28 公布的「电子信息产品污染控制管理办法」以及 SJ/T 11364-2006「电子信息产品污染控制标识要求」的规定，适用于在中国销售的电子信息产品的环保使用期限。仅限于在遵守该产品的安全规范及使用注意事项的基础上，从生产日起算的该年限内，不会因产品所含有害物质的泄漏或突发性变异，而对环境污染，人身及财产产生深刻地影响。  
 注：电池的环保使用期限是 5 年。生产日期标于产品序号的前四码（如 S/N 0728XXXX 为 07 年第 28 周生产）。

Equipment marked with the Crossed-out Wheelie Bin symbol complies with the European Parliament and Council Directive 2002/96/EC (the "WEEE Directive") in the European Union.



For Products placed on the EU market after August 13, 2005, please contact your local Anritsu representative at the end of the product's useful life to arrange disposal in accordance with your initial contract and the local law.



---

## Safety Symbols

---

To prevent the risk of personal injury or loss related to equipment malfunction, Anritsu Company uses the following symbols to indicate safety-related information. For your own safety, please read the information carefully *before* operating the equipment.

### Symbols Used in Manuals

#### Danger



This indicates a very dangerous procedure that could result in serious injury or death, or loss related to equipment malfunction, if not performed properly.

#### Warning



This indicates a hazardous procedure that could result in light-to-severe injury or loss related to equipment malfunction, if proper precautions are not taken.

#### Caution



This indicates a hazardous procedure that could result in loss related to equipment malfunction if proper precautions are not taken.

### Safety Symbols Used on Equipment and in Manuals

The following safety symbols are used inside or on the equipment near operation locations to provide information about safety items and operation precautions. Ensure that you clearly understand the meanings of the symbols and take the necessary precautions *before* operating the equipment. Some or all of the following five symbols may or may not be used on all Anritsu equipment. In addition, there may be other labels attached to products that are not shown in the diagrams in this manual.



This indicates a prohibited operation. The prohibited operation is indicated symbolically in or near the barred circle.



This indicates a compulsory safety precaution. The required operation is indicated symbolically in or near the circle.



This indicates a warning or caution. The contents are indicated symbolically in or near the triangle.



This indicates a note. The contents are described in the box.



These indicate that the marked part should be recycled.



## For Safety

### Warning



Always refer to the operation manual when working near locations at which the alert mark, shown on the left, is attached. If the operation, etc., is performed without heeding the advice in the operation manual, there is a risk of personal injury. In addition, the equipment performance may be reduced. Moreover, this alert mark is sometimes used with other marks and descriptions indicating other dangers.

### Warning

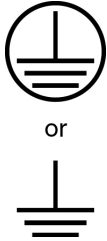

When supplying power to this equipment, connect the accessory 3-pin power cord to a 3-pin grounded power outlet. If a grounded 3-pin outlet is not available, use a conversion adapter and ground the green wire, or connect the frame ground on the rear panel of the equipment to ground. If power is supplied without grounding the equipment, there is a risk of receiving a severe or fatal electric shock.

### Warning



This equipment can not be repaired by the operator. Do not attempt to remove the equipment covers or to disassemble internal components. Only qualified service technicians with a knowledge of electrical fire and shock hazards should service this equipment. There are high-voltage parts in this equipment presenting a risk of severe injury or fatal electric shock to untrained personnel. In addition, there is a risk of damage to precision components.

### Caution



Electrostatic Discharge (ESD) can damage the highly sensitive circuits in the instrument. ESD is most likely to occur as test devices are being connected to, or disconnected from, the instrument's front and rear panel ports and connectors. You can protect the instrument and test devices by wearing a static-discharge wristband.

Alternatively, you can ground yourself to discharge any static charge by touching the outer chassis of the grounded instrument before touching the instrument's front and rear panel ports and connectors. Avoid touching the test port center conductors unless you are properly grounded and have eliminated the possibility of static discharge.

Repair of damage that is found to be caused by electrostatic discharge is not covered under warranty.

# Table of Contents

---

## Chapter 1—General Information

1-1	Introduction . . . . .	1-1
1-2	Available Models . . . . .	1-1
1-3	Available Options . . . . .	1-2
1-4	Standard Accessories . . . . .	1-3
1-5	Optional Accessories . . . . .	1-4
1-6	Additional Documents . . . . .	1-4
1-7	Instrument Description . . . . .	1-4
1-8	Spectrum Master Specifications . . . . .	1-5
1-9	Calibration Requirements . . . . .	1-5
1-10	Preventive Maintenance . . . . .	1-5
1-11	ESD Cautions . . . . .	1-5
1-12	Anritsu Reference Documents . . . . .	1-6
1-13	Anritsu Service Centers . . . . .	1-6
1-14	Battery Replacement . . . . .	1-7
1-15	Soft Carrying Case . . . . .	1-8
1-16	Tilt Bail Stand . . . . .	1-9
1-17	Secure-Environment Workplace . . . . .	1-9
	Option 7, Secure Data . . . . .	1-9
	Spectrum Master Memory Types . . . . .	1-10
	Erase All User Files in Internal Memory . . . . .	1-11
	Recommended Usage in a Secure Environment . . . . .	1-11

## Chapter 2—Instrument Overview

2-1	Introduction . . . . .	2-1
2-2	Hardware Overview . . . . .	2-2
	Turning On the MS272xC for the First Time . . . . .	2-2
2-3	Front Panel Overview . . . . .	2-3
2-4	Front Panel Keys . . . . .	2-4
	Main Menu Keys . . . . .	2-5
	Submenu Keys . . . . .	2-5
2-5	Mode Selector Menu . . . . .	2-6
2-6	Secondary Function Menus . . . . .	2-7
2-7	Display Overview . . . . .	2-8
	Spectrum Analyzer Mode . . . . .	2-8

## Table of Contents (Continued)

---

2-8	Parameter Setting . . . . .	2-9
2-9	Text Entry . . . . .	2-9
2-10	Test Panel Connectors . . . . .	2-12
2-11	Symbols and Indicators. . . . .	2-14
2-12	Firmware Overview . . . . .	2-16
	Main Menu Keys . . . . .	2-16
	Submenu Keys . . . . .	2-16

### Chapter 3—Quick Start Guide

3-1	Introduction . . . . .	3-1
3-2	Measurement Setup . . . . .	3-2
	Connect the Input Source . . . . .	3-2
	Editing and Entering Values . . . . .	3-2
	Selecting the Analyzer Mode . . . . .	3-2
3-3	Set the Measurement Frequency . . . . .	3-3
	Using Start and Stop Frequencies . . . . .	3-3
	Entering Center Frequency . . . . .	3-3
	Selecting Signal Standard . . . . .	3-3
	Setting Measurement Frequency Bandwidth . . . . .	3-3
3-4	Set the Amplitude . . . . .	3-4
	Setting Amplitude Reference Level and Scale . . . . .	3-4
	Setting Amplitude Range and Scale . . . . .	3-4
	Reference Level Offset for External Loss or External Gain . . . . .	3-5
3-5	Set the Span . . . . .	3-5
3-6	Setting Up Limit Lines . . . . .	3-6
	Simple Limit Line . . . . .	3-6
	Limit Line Envelope . . . . .	3-6
	Complex Limit Lines . . . . .	3-7
3-7	Setting Up Markers . . . . .	3-8
3-8	Selecting a Measurement Type . . . . .	3-9
3-9	Saving Measurements . . . . .	3-9
3-10	Master Software Tools . . . . .	3-9

# Table of Contents (Continued)

---

## Chapter 4—File Management

4-1	Introduction . . . . .	4-1
4-2	Managing Files . . . . .	4-1
	Save Files . . . . .	4-1
	Recall Files . . . . .	4-2
	Recall Dialog Box . . . . .	4-2
	Copying Files . . . . .	4-3
	Deleting Files . . . . .	4-5
	Delete Dialog Box . . . . .	4-5
4-3	File Menu Overview . . . . .	4-6
4-4	File Menu . . . . .	4-7
	Save Menu . . . . .	4-8
	Save Location Menu . . . . .	4-9
	Save On Event Menu . . . . .	4-10
	Recall Menu . . . . .	4-11
	Copy Menu . . . . .	4-12
	Delete Menu . . . . .	4-13

## Chapter 5—System Operation

5-1	Introduction . . . . .	5-1
5-2	System Menu Overview . . . . .	5-1
5-3	System Menu . . . . .	5-2
	System Options Menu . . . . .	5-3
	Display Settings Menu . . . . .	5-4
	Reset Menu . . . . .	5-5
5-4	Preset Menu . . . . .	5-6
5-5	Self Test . . . . .	5-6
5-6	Update Firmware . . . . .	5-7
	Using a USB Memory Device . . . . .	5-7
	Update Firmware Using Master Software Tools . . . . .	5-9

## Chapter 6—GPS (Option 31)

6-1	Introduction . . . . .	6-1
6-2	Setting Up GPS (Option 31) . . . . .	6-1
	Activating the GPS feature: . . . . .	6-1

# Table of Contents (Continued)

---

## **Chapter 7—Master Software Tools**

7-1	Introduction . . . . .	7-1
7-2	Master Software Tools Overview . . . . .	7-1
7-3	MST Feature Overview . . . . .	7-1
7-4	Installing MST . . . . .	7-2
7-5	Updating Instrument Firmware . . . . .	7-2
	Update Firmware by Using a USB Device . . . . .	7-6
7-6	Emergency Repair Procedure . . . . .	7-7

## **Appendix A—Measurement Guides**

A-1	Introduction . . . . .	A-1
-----	------------------------	-----

## **Appendix B—Error Messages**

B-1	Introduction . . . . .	B-1
B-2	Self Test or Application Self Test Error Messages . . . . .	B-1
B-3	Operation Error Messages . . . . .	B-2

## **Appendix C—LAN and DHCP**

C-1	Introduction . . . . .	C-1
C-2	Ethernet Configuration . . . . .	C-1
	LAN Connection . . . . .	C-1
	Ethernet Config . . . . .	C-3
	Ethernet Menu . . . . .	C-4
C-3	DHCP . . . . .	C-5
	Example 1 . . . . .	C-5
	Example 2 . . . . .	C-6
C-4	ipconfig Tool . . . . .	C-6
C-5	Ping Tool . . . . .	C-7

## **Index**

# Chapter 1 — General Information

## 1-1 Introduction

This chapter provides a description of the handheld Anritsu Spectrum Master™ models MS2722C, MS2723C, MS2724C, MS2725C, and MS2726C, referred to collectively as model series MS272xC. It also briefly describes preventive maintenance, calibration requirements, ESD cautions, and additional documents.

General and performance specifications, instrument options, standard accessories, and optional accessories are in the Spectrum Master Technical Data Sheets:

- PN: 11410-00529 for MS2722C
- PN: 11410-00524 for MS2723C
- PN: 11410-00525 for MS2724C
- PN: 11410-00526 for MS2725C
- PN: 11410-00527 for MS2726C

Refer to [Appendix A, “Measurement Guides”](#), for additional information. Throughout this manual, these instruments may be referred to as a Spectrum Master or as a model MS2722C, MS2723C, MS2724C, MS2725C, MS2726C, or as model MS272xC.

## 1-2 Available Models

[Table 1-1](#) lists the Spectrum Master models and frequency range described in this User Guide.

**Table 1-1.** Spectrum Master Model

Model	Frequency Range
MS2722C	Spectrum Analyzer, 9 kHz to 9 GHz
MS2723C	Spectrum Analyzer, 9 kHz to 13 GHz
MS2724C	Spectrum Analyzer, 9 kHz to 20 GHz
MS2725C	Spectrum Analyzer, 9 kHz to 32 GHz
MS2726C	Spectrum Analyzer, 9 kHz to 43 GHz

## 1-3 Available Options

Available options for the Spectrum Master is shown in [Table 1-2](#).

**Table 1-2.** Available Options (1 of 2)

<b>MS2722C-xxxx</b> <b>MS2723C-xxxx</b> <b>MS2724C-xxxx</b> <b>MS2725C-xxxx</b> <b>MS2726C-xxxx</b>	<b>Description</b>
0007	Secure Data Operation
0019	High-Accuracy Power Meter (sensor not included)
0031	GPS Receiver (Requires GPS Antenna 2000-1523-R)
0025	Interference Analyzer
0027	Channel Scanner
0089	Zero-Span IF Output
0009	I/Q Demodulation Hardware
0040	GSM/GPRS/EDGE RF Measurements <sup>(1)</sup>
0041	GSM/GPRS/EDGE Demodulation <sup>(1)</sup>
0035	W-CDMA/HSDPA Over-the-Air Measurements <sup>(2)</sup>
0044	W-CDMA/HSDPA RF Measurements <sup>(1)</sup>
0045	W-CDMA Demodulation (mutually exclusive with 0065) <sup>(1)</sup>
0065	W-CDMA/HSDPA Demodulation (mutually exclusive with 0045) <sup>(1)</sup>
0038	TD-SCDMA/HSDPA Over-the-Air Measurements <sup>(1)</sup>
0060	TD-SCDMA/HSDPA Measurements <sup>(1)</sup>
0061	TD-SCDMA/HSDPA Demodulation <sup>(1)</sup>
0541	LTE RF Measurements <sup>(1)</sup>
0542	LTE Modulation Measurements <sup>(1)</sup>
0543	LTE Bandwidths 15 MHz and 20 MHz (requires option 0541 or 0542)
0546	LTE Over-the-Air Measurements <sup>(1)</sup>
0033	cdmaOne/CDMA2000 1X Over-the-Air Measurements <sup>(2)</sup>
0042	cdmaOne/CDMA2000 1X RF Measurements <sup>(1)</sup>
0043	cdmaOne/CDMA2000 1X Demodulation <sup>(1)</sup>
0062	CDMA2000 1xEV-DO RF Measurements <sup>(1)</sup>
0063	CDMA2000 1xEV-DO Demodulation <sup>(1)</sup>
0034	CDMA2000 1xEV-DO Over-the-Air Measurements <sup>(2)</sup>

**Table 1-2.** Available Options (2 of 2)

MS2722C-xxxx MS2723C-xxxx MS2724C-xxxx MS2725C-xxxx MS2726C-xxxx	Description
0046	IEEE 802.16 Fixed WiMAX RF Measurements <sup>(1)</sup>
0047	IEEE 802.16 Fixed WiMAX Demodulation <sup>(1)</sup>
0037	IEEE 802.16 Mobile WiMAX Over-the-Air Measurements <sup>(1)</sup>
0066	IEEE 802.16 Mobile WiMAX RF Measurements <sup>(1)</sup>
0067	IEEE 802.16 Mobile WiMAX Demodulation <sup>(1)</sup>
0098	Standard Calibration to Z540
0099	Premium Calibration to Z540 plus test data

1. Requires Option 0009.
2. Requires Option 0009 and Option 0031.

## 1-4 Standard Accessories

The Anritsu Spectrum Master includes a one year warranty which includes: battery, firmware, software, and Certificate of Calibration and Conformance. The following items are supplied with the product.

**Table 1-3.** Standard Accessories for Spectrum Master Models

Part Number	Description
10580-00277	Spectrum Master User Guide
2300-498	MST CD: Master Software Tools
65729	Soft Carrying Case
633-44	Rechargeable Li-Ion Battery
40-168-R	AC-DC Adapter
806-141-R	Automotive Cigarette Lighter Adapter
2000-1371-R	Ethernet Cable, 7 feet/213 cm
3-2000-1498	USB A-mini B Cable, 10 feet/305 cm
Listed in Section 1-1	Spectrum Master MS272xC Technical Data Sheet

### Caution

When using the Automotive Cigarette Lighter Adapter, Anritsu Part Number 806-141-R, always verify that the supply is rated for a minimum of 60 Watts at 12 VDC, and that the socket is clear of any dirt or debris. If the adapter plug becomes hot to the touch during operation, then discontinue use immediately.



## 1-5 Optional Accessories

The Spectrum Master Technical Data Sheet listed in [Section 1-1](#) contains a list and description of available optional accessories. The data sheet is available on the Anritsu web site: <http://www.anritsu.com>.

## 1-6 Additional Documents

This user guide is specific to the Spectrum Master MS272xC (models MS2722C, MS2723C, MS2724C, MS2725C, and MS2726C). Additional instrument functions and descriptions of optional measurement capabilities are described in measurement guides. Refer to [Appendix A, "Measurement Guides"](#) for a list of these guides and their Anritsu part numbers. Measurement guides are provided on the Documentation disc that is shipped with the instrument and are also available for download (at no charge) from the Anritsu web site. Refer to section ["Anritsu Reference Documents"](#) on page 1-6.

## 1-7 Instrument Description

The Spectrum Master is a synthesizer-based handheld spectrum analyzer that provides quick and accurate measurement results. Measurements can be easily made by using the main instrument functions: frequency, span, amplitude, and bandwidth. Dedicated keys for common functions and a familiar calculator-type keypad are available for fast data entry.

Time and date stamping of measurement data is automatic. The internal memory provides for the storage and recall of up to 1000 measurement setups and up to 1000 traces using Master Software Tools (MST). External storage can be used for bulk measurement storage. The bright daylight-viewable, high-resolution, color liquid crystal display (LCD) provides easy viewing in a variety of lighting conditions. The Spectrum Master is capable of up to 2.5 hours of continuous operation from a fully charged battery and can be operated from a 12 VDC source, which also simultaneously charges the battery.

The Spectrum Master is designed for monitoring, measuring, and analyzing signal environments. Typical measurements include: in-band interference and transmit spectrum analysis, plus cell site and 802.11a/b/g interference testing. Options are available for RF, advanced demodulation, and over-the-air (OTA) measurement. A full range of marker capabilities (such as peak, center, and delta functions) are provided for faster, more comprehensive analysis of displayed signals. Upper and lower multi-segmented limit lines are available to create quick, simple pass/fail measurements. A menu option provides for an audible alert when a limit value is exceeded.

In transmitter analyzer mode, the Spectrum Master displays six markers and the marker table in Code Domain Power and Codogram displays. In Spectrum Analyzer mode, a full range of marker capabilities is provided. Markers are not available in GSM mode.

Anritsu Master Software Tools, a PC-based software program, provides for storing measurement data. Master Software Tools can also convert the Spectrum Master display into several graphic formats.

Measurements may be stored in the internal memory or a USB flash drive. Stored measurements can be downloaded to a PC by using the included USB and Ethernet cables. After being stored, the graphic trace can then be displayed, scaled, or enhanced with markers and limit lines. Historical graphs can be overlaid with current data by using the PC mouse in drag-and-drop fashion. The underlying data can be extracted and used in spreadsheets or for other analytical tasks.

## 1-8 Spectrum Master Specifications

Refer to the Technical Data Sheet listed in [Section 1-1](#) for general specifications, detailed measurement specifications for all available measurement modes, ordering information, power sensors, and available accessories. The data sheet is included with the instrument and also available on the Anritsu web site: <http://www.anritsu.com>.

## 1-9 Calibration Requirements

The Spectrum Master loads factory calibration data during start-up, eliminating the need for daily calibration checks. In WCDMA modes, an additional automatic calibration is performed as the internal temperature of the Spectrum Master changes (to insure the best possible measurement results).

Although the Spectrum Master does not require daily field calibration, Anritsu Company recommends annual calibration and performance verification by local Anritsu service centers.

## 1-10 Preventive Maintenance

Spectrum Master preventive maintenance consists of cleaning the unit and inspecting and cleaning the RF connectors on the instrument and on all accessories. Clean the Spectrum Master with a soft, lint-free cloth that is dampened with water or with water and a mild cleaning solution.

<b>Caution</b> To avoid damage to the display or case, do not use solvents or abrasive cleaners.
--

Clean the RF connectors and center pins with a cotton swab dampened with denatured alcohol. Visually inspect the connectors. The fingers of N(f) connectors and the pins of N(m) connectors should be unbroken and uniform in appearance. If you are unsure whether the connectors are good, then gauge the connectors to confirm that their dimensions are correct.

Visually inspect test port cables. Test port cables should be uniform in appearance, not stretched, kinked, dented, or broken.

## 1-11 ESD Cautions

The MS272xC, like other high performance instruments, is susceptible to ESD (electrostatic discharge) damage. Coaxial cables and antennas often build up a static charge, which may damage the MS272xC input circuitry (if allowed to discharge by connecting directly to the MS272xC without previously discharging the static charge). MS272xC operators must be aware of the potential for ESD damage and take all necessary precautions.

Operators should exercise practices outlined within industry standards such as JEDEC-625 (EIA-625), MIL-HDBK-263, and MIL-STD-1686, which pertain to ESD and ESDS devices, equipment, and practices. Because these apply to the MS272xC, Anritsu Company recommends that any static charges that may be present be dissipated before connecting coaxial cables or antennas to the MS272xC. This may be as simple as temporarily attaching a short or load device to the cable or antenna prior to attaching to the MS272xC. Remember that the operator may also carry a static charge that can cause damage. Following the practices outlined in the above standards ensures a safe environment for both personnel and equipment.

## 1-12 Anritsu Reference Documents

The following URL is an Internet link to the Spectrum Master product page.

Spectrum Master product page link: <http://www.us.anritsu.com/SpectrumMaster>

A table at the bottom of each Spectrum Master web page presents Internet links to related literature and software. Examples include the following types of documents:

- Application Notes
- Brochures
- Data Sheets
- Instruction Sheets
- Technical Notes
- White Papers
- Master Software Tools

## 1-13 Anritsu Service Centers

For the latest service and sales information in your area, please visit the following URL:

<http://www.anritsu.com/Contact.asp>

and choose a country for regional contact information.

## 1-14 Battery Replacement

The battery can be replaced without the use of tools. The battery compartment is located on the lower left side of the instrument (when you are facing the measurement display). Slide the battery door down, towards the bottom of the instrument, to remove it. Remove the battery pack from the instrument by pulling straight out on the battery lanyard. Replacement is the opposite of removal.



**Figure 1-1.** Battery Compartment Door

**Note** Use only Anritsu approved batteries, adapters, and chargers with this instrument.

The battery that is supplied with the Spectrum Master may need charging before use. The battery can be charged while it is installed in the Spectrum Master by using either the AC-DC Adapter (40-168-R) or the 12-Volt DC adapter (806-141-R), or separately in the optional Dual Battery Charger (2000-1374). Refer to section “[Symbols and Indicators](#)” on [page 2-14](#) for a description of battery symbols.

**Caution** When using the Automotive Cigarette Lighter Adapter, Anritsu Part Number 806-141-R, always verify that the supply is rated for a minimum of 60 Watts @ 12 VDC, and that the socket is clear of any dirt or debris. If the adapter plug becomes hot to the touch during operation, then discontinue use immediately.

**Note** Anritsu Company recommends removing the battery for long-term storage of the instrument.

## 1-15 Soft Carrying Case

The instrument can be operated while in the soft carrying case. On the back of the case is a large storage pouch for accessories and supplies.

To install the instrument into the soft carrying case:

1. The front panel of the case is secured with hook-and-loop fasteners. Fully close the front panel of the case. When closed, the front panel supports the shape of the case while you are inserting the Spectrum Master.
2. Place the soft carrying case face down on a stable surface, with the front panel fully closed and laying flat.
3. Fully open the zippered back of the case.

**Note**

Two zippers provide access around the back of the case. The zipper closer to the front of the case opens the case back, and allows access to install and remove the instrument. The zipper closer to the back of the case opens a support panel that can be used to provide support for improved stability and air flow while the instrument is in the case. This support panel also contains the storage pouch.

4. Insert the instrument face down into the case, taking care that the connectors are properly situated in the case top opening. You may find it easier to insert the connectors first, then pull the corners over the bottom of the Spectrum Master.



**Figure 1-2.** Instrument Inserted Into the Soft Carrying Case

5. Close the back panel and secure with the zipper.

The soft carrying case includes a detachable shoulder strap, which can be connected to the D-rings on the upper corners of the case, as required for comfort or convenience.

## 1-16 Tilt Bail Stand

The attached Tilt Bail can be used for desktop operation. The tilt bail provides a backward tilt for improved stability and air flow. To deploy the tilt bail, pull the bottom of the tilt bail away from the back of the instrument. To store the tilt bail, push the bottom of the bail towards the back of the instrument and snap the bail into the clip on the back of the instrument.

## 1-17 Secure-Environment Workplace

This section describes the Option 7 and Frequency Blanking, types of memory in the Spectrum Master, how to delete stored user files in internal memory, and recommended usage in a secure-environment workplace.

### Option 7, Secure Data

Option 0007, Secure Data will set the instrument to only allow saving information to an external USB flash drive. Saving to the internal memory is disabled.

**Caution**

Note that even with Option 7 enabled, operating parameters (such as frequency range and power level) that are set by the user are stored in the Spectrum Master EEPROM when the Spectrum Master is turned OFF. These parameters can be erased, however, via a Master Reset operation, as described later in this chapter.

### Frequency Blanking

Option 7 allows the user to hide the displayed frequency values. Frequency values displayed on the screen and menus are replaced with **##.####**. To enable frequency blanking press the **Shift** key, then the **System** (8) key. Press the **System Options** submenu key, then the **Reset** submenu key. Press the **Frequency Blanking** submenu key so that **On** is underlined. Setting Frequency Blanking back to **Off** will preset the instrument to factory default settings.

After frequency blanking is enabled the user is not able to restore the frequency readouts. Following is a list of the security measures that have been taken to protect the frequency information after Frequency Blanking is turned on.

1. Turning off frequency blanking presets the instrument (and the frequencies) to the factory default settings.
2. Turning off the instrument presets the instrument to the factory default settings and turns off frequency blanking.
3. Presetting the instrument turns off frequency blanking and restores the factory default settings.
4. Frequency blanking is available only with Option 7 to ensure that user files and calibration files are not stored in the internal memory of the instrument.

**Warning**

Note that when Frequency Blanking is turned on user files can still be stored and saved to an external USB drive, and that frequency information is not blanked in those files. Also, frequency information is not blanked from the SCPI commands that are used to remotely control the instrument.

## Spectrum Master Memory Types

The instrument contains non-volatile disk-on-a-chip memory, EEPROM, and volatile DRAM memory. The instrument does not have a hard disk drive or any other type of volatile or non-volatile memory.

### EEPROM

This memory stores the model number, serial number, and calibration data for the instrument. Also stored here are the user-set operating parameters, such as frequency range. During the master reset process, all operating parameters that are stored in the EEPROM are set to standard factory default values.

### RAM Memory

This is volatile memory that is used to store parameters that are needed for the normal operation of the instrument along with current measurements. This memory is reset whenever the instrument is restarted.

### External USB Flash Drive (not included with the instrument)

This memory may be selected as the destination for saved measurements and setups for the instrument. You can also copy the contents of the internal disk-on-chip memory to the external flash memory for storage or data transfer. The external Flash USB can be reformatted or sanitized using software on a PC.

Refer to the [Chapter 4, "File Management"](#) for additional information about saving and copying files to the USB flash drive.

## Erase All User Files in Internal Memory

Perform a Master Reset:

1. Turn on the instrument.
2. Press the **Shift** button then the **System** (8) button.
3. Press the System Options submenu key.
4. Press the Reset key, then the Master Reset key.
5. A dialog box will be displayed on the screen warning that all settings will be returned to factory default values, and that all user files will be deleted. This deletion is a standard file delete and does not involve overwriting exiting information.
6. Press the **Enter** button to complete the master reset.
7. The instrument reboots, and the reset is complete.

## Recommended Usage in a Secure Environment

The Spectrum Master does not currently provide a secure erase feature. In environments where data security is an issue, Anritsu Company recommends that you store your Spectrum Master-created files on an external USB Flash drive that is then securely retained, sanitized, or destroyed after use.

To set the Spectrum Master to save files to an external USB Flash drive:

1. Attach the external Flash drive and turn on the instrument.
2. Press the **Shift** button then the **File** (7) button.
3. Press the Save submenu key.
4. Press the Change Save Location and using the arrow keys or rotary knob, select the location on the USB drive where the files are to be saved.
5. Press the Set Location submenu key.
6. Press **Esc** to clear the Save dialog box.

The external USB drive location is now the default location for saving files.





# Chapter 2 — Instrument Overview

## 2-1 Introduction

This chapter provides a brief overview of the Anritsu MS272xC Spectrum Master. The intent of this chapter is to acquaint you with the instrument. To begin using the instrument immediately, go to [Chapter 3, “Quick Start Guide”](#), to find directions for power on, editing, frequency, bandwidth, amplitude, limit line, marker, file management procedures, and firmware update. For more detailed information on measurement setups, refer to the specific measurement guides, which are based on the options that can be purchased for this instrument. The measurement guides and a copy of this user guide are available as PDF files on the Documentation disc or the Anritsu web site (<http://www.anritsu.com>). Refer to [Appendix A, “Measurement Guides”](#).

## 2-2 Hardware Overview

### Turning On the MS272xC for the First Time

The Anritsu MS272xC Spectrum Master is capable of approximately 2.5 hours of continuous operation from a fully charged, field-replaceable battery (refer to Section “[Battery Replacement](#)” on page 1-7 of [Chapter 1](#)). The MS272xC can also be operated from a 12 VDC source (which will also simultaneously charge the battery). This can be achieved with either the Anritsu AC–DC Adapter (Anritsu part number 40-168-R) or Automotive Cigarette Lighter Adapter (Anritsu part number 806-141-R). Both items are included as standard accessories (refer to the list of accessories in the Technical Data Sheet for your specific instrument, as listed in section “[Introduction](#)” on page 1-1).

**Caution** When using the Automotive Cigarette Lighter Adapter, Anritsu Part Number 806-141-R, always verify that the supply is rated for a minimum of 60 Watts at 12 VDC and that the socket is clear of any dirt or debris. If the adapter plug becomes hot to the touch during operation, then discontinue use immediately.

To turn on the MS272xC, press the **On/Off** button on the front panel ([Figure 2-1](#)).



**Figure 2-1.** MS272xC On/Off Button

The MS272xC Spectrum Master takes approximately forty seconds to complete power-up and to load the application software. At the completion of this process, the instrument is ready to be used.

## 2-3 Front Panel Overview

The Spectrum Master menu-driven interface is easy to use and requires little training. Hard keys on the front panel are used to initiate function-specific menus. Five main menu keys are located below the display. These keys vary in function depending upon the selected mode of instrument operation.

A rotary knob and 21 hard keys are located to the right of the measurement display. Nine of the hard keys are dual purpose, depending upon the current mode of operation. The dual-purpose keys are labeled with a number on the key itself. The alternate function is printed on the panel above each of these nine keys. Use the shift key to access the functions that are printed on the panel. The **Escape** key (which is used for aborting data entry) is the round button located above the submenu keys. The rotary knob, the four arrow keys, and the keypad can be used to change the value of an active parameter. The rotary knob can also be pressed to duplicate the action of the **Enter** key.

Arranged in a vertical column on the instrument case and along the right edge of the measurement display are 8 submenu keys. They change function depending upon the current menu selection. The current submenu key function is indicated in the active function block (submenu key labels) on the right edge and within the measurement display. An example of the keys is shown in [Figure 2-2](#).

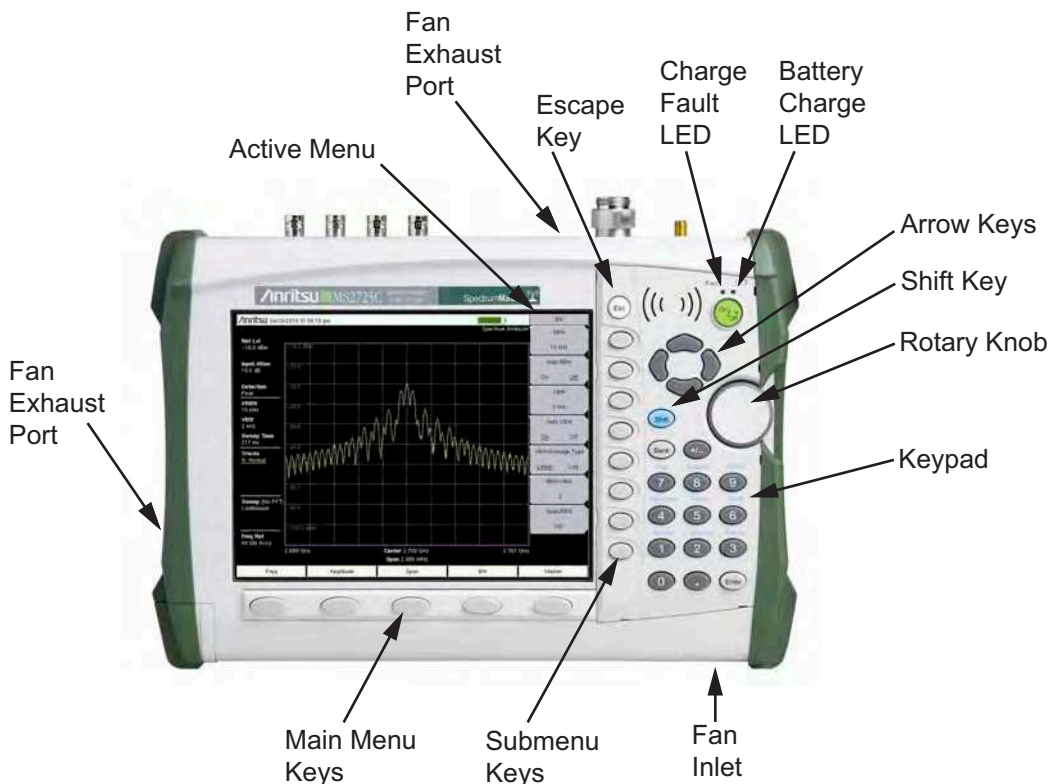

**Figure 2-2.** Front Panel Overview

Other features on the front panel include:

### Battery Charge LED (Green)

The Battery Charge LED flashes if the battery is charging, and remains on steady when the battery is fully charged.

### Charge Fault LED (Red)

The Charge Fault LED remains on under a battery charger fault condition. Fault conditions include a battery cell voltage that is too low to charge or a battery temperature that is outside the temperature range ( $-5^{\circ}\text{C}$  to  $+45^{\circ}\text{C}$ ) for charging.

### Fan Inlet and Exhaust Ports

Keeping the fan inlet and exhaust ports clear of obstructions at all times is important for proper ventilation and cooling of the instrument.

## 2-4 Front Panel Keys

The term hard key refers to all of the buttons on the instrument face except for the vertical row of 8 gray buttons adjacent to the right edge of the measurement display screen (the 8 submenu keys) and the horizontal row of 5 gray buttons below the measurement display screen (the 5 main menu keys).

The hard keys perform as follows:

### Esc Key

Press this key to cancel any setting that is currently being made.

### Enter Key

Press this key to finalize data input. Pressing the rotary knob performs this same function.

### Arrow Keys

The four arrow keys (between the rotary knob and the **Esc** key) are used to scroll up, down, left, or right. The arrow keys can often be used (depending upon measurement selection) to change a value or to change a selection from a list. This function is similar to the function of the rotary knob. In some measurements, the **Left/Right** arrow keys change values by different increments than the **Up/Down** arrow keys or the rotary knob. The arrow keys are also used to move markers.

### Shift Key

Press the **Shift** key and then press a number key to open the menu that is indicated in blue text above the number key. When the **Shift** key is active, its icon is displayed at the top-right of the measurement display area between the battery charge indicator and the submenu label.



**Figure 2-3.** Shift Key Icon

The **Shift** key is also used for UPPERCASE letters when entering text (refer to [“Text Entry” on page 2-9](#)).

### Back Key

Press this key to delete only one character, one number, or the range that is specified by the cursor.

### +/- Key

Press this key to change the sign of numbers that are entered with the number keys.

### Number Keypad

Press these keys to directly input numbers. Number keys 1 through 9 are also used to open menus. Refer to the functions of the [“Shift Key”](#).

### Rotary Knob

Turn the rotary knob to change numerical values, to scroll through selectable items within a list, and to move markers. Values or items may be within a dialog box or an edit window.

Press the rotary knob to finalize the input function in the same manner as pressing the **Enter** key.

## Main Menu Keys

The 5 main menu keys are horizontally arranged adjacent to the measurement display screen and along its lower edge. These keys (buttons) have no printed labels. They are positioned to accompany virtual key labels that are displayed in the measurement display area. These main menu key labels change to match specific instrument Mode settings. Each Mode has a specific set of main menu keys. For details about the main menu keys, refer to the section [“Firmware Overview” on page 2-16](#). For details about the Mode settings, refer to section [“Mode Selector Menu” on page 2-6](#).

## Submenu Keys

These 8 gray keys (buttons) have no printed labels. They are arranged adjacent to the measurement display screen along the right-hand edge. They are positioned to accompany virtual submenu key labels that are displayed to match instrument modes and measurement functions. The submenu label area is also called the Active Function Block (refer to [Figure 2-2 on page 2-3](#)). The virtual key labels change as instrument measurement settings change.

## 2-5 Mode Selector Menu

To access the functions under the Mode menu, select the **Shift** key, then the **Mode** (9) key. Use the directional arrow keys or the rotary knob to highlight the selection, and press the **Enter** key to select. The list of modes that appears in this menu will vary depending upon the options that are installed and activated in your instrument. [Figure 2-4](#) is an example of the Mode menu. Your instrument may not show the same list.

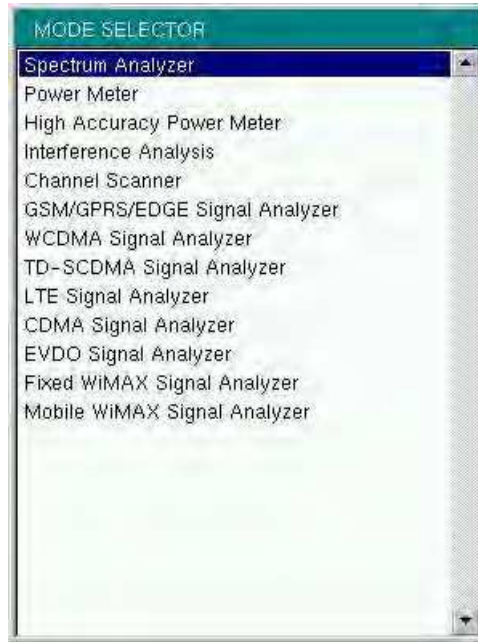

**Figure 2-4.** Mode Selector Menu

## 2-6 Secondary Function Menus

Pressing the **Shift** key and then a number key selects the menu function that is printed in blue characters above the number key (Figure 2-5).

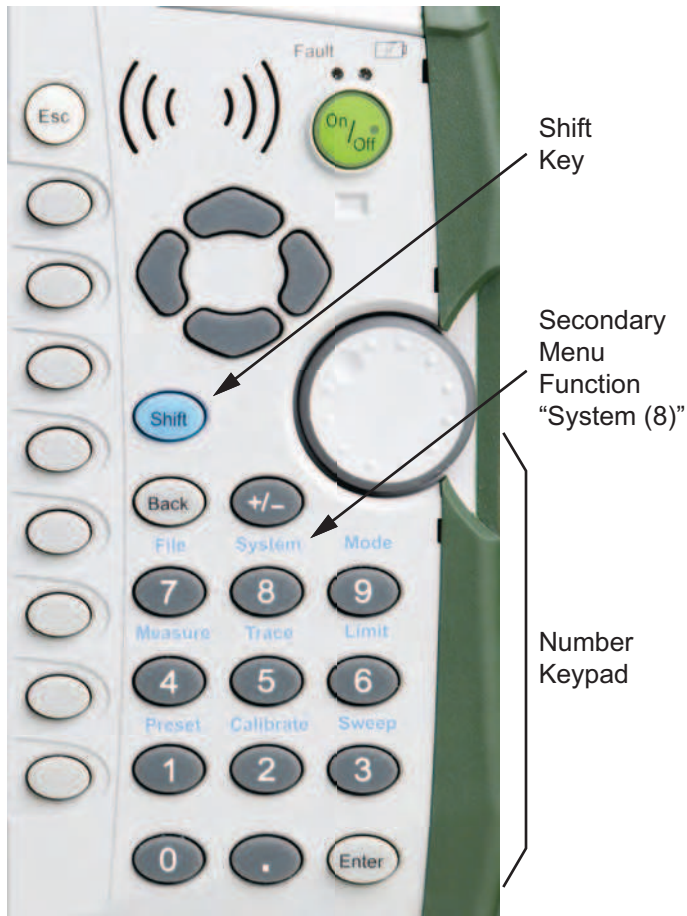

**Figure 2-5.** Keypad and Secondary Function Menu

Not all Secondary Function Menus are active in various operation Modes. If any one of these 9 menus is available in a specific instrument Mode of operation, then it can be called from the number keypad. It may also be available from a main menu key or a submenu key. The Secondary Function Menus are: **Preset** (1), **Calibrate** (2), **Sweep** (3), **Measure** (4), **Trace** (5), **Limit** (6), **File** (7), **System** (8), and **Mode** (9).



## 2-7 Display Overview

Typical measurement displays are shown for the basic Spectrum Analyzer mode of the MS272xC. Note that the images shown in this manual may be different from any images that are displayed on your Spectrum Master.

### Spectrum Analyzer Mode

Figure 2-6 illustrates some of the key information areas of the MS272xC display. For more detailed key descriptions of the Spectrum Analyzer mode, refer to the Spectrum Analyzer Measurement Guide (Anritsu part number 10580-00244, available on the Documentation disc or the Anritsu web site). Also refer to Appendix A, “Measurement Guides”, for a complete list of measurement guides.

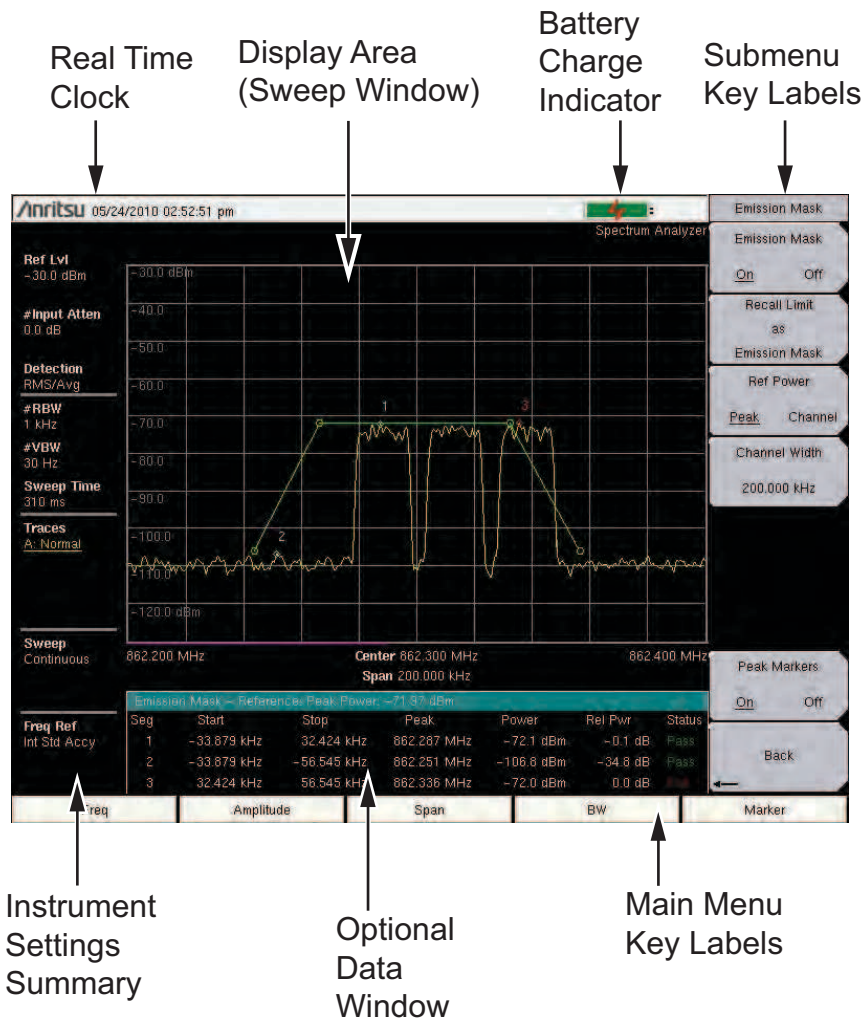

Figure 2-6. Spectrum Analyzer Display

## 2-8 Parameter Setting

Pop-up list boxes or edit boxes are used to provide selection lists and selection editors. Scroll through a list of items or parameters with the arrow keys or the rotary knob. Select numerical values by scrolling with the arrow keys or rotary knob or by entering the digits directly from the number keypad. These list boxes and edit boxes frequently display a range of possible values or limits for possible values.

Finalize the input by pressing the rotary knob or the **Enter** key. At any time before finalizing the input, press the escape (**Esc**) key to abort the change and retain the previously existing setting.

Some parameters (such as for antennas or couplers) can be added to list boxes by creating them and importing them through the use of Master Software Tools.

## 2-9 Text Entry

When entering text (as when saving a measurement) the submenu key for Text Entry displays the characters (alphabet, hyphen, and underscore) in 6 letters per key (Refer to [Figure 2-9](#)). Characters can be entered by using the rotary knob or by using the submenu keys. Refer to [Figure 2-7](#), [Figure 2-8](#) and [Figure 2-9](#).

The rotary knob scrolls through the characters in a pop-up window and is pressed to select each character in sequence.

Alternatively, press the a b c / d e f submenu key (for example) to open another submenu with a separate key for each of these letters. The menu returns to the complete character set after each individual letter is entered.

Use the arrow keys to navigate within a name or character string. Use the **Shift** key for capital letters. Press the **Enter** key or the rotary knob to finalize a text entry.

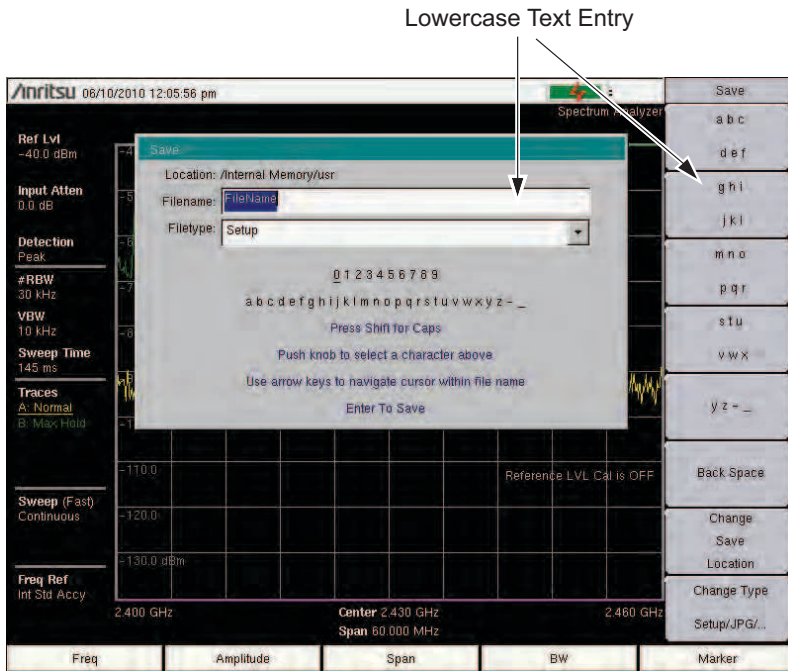

Figure 2-7. Text Entry Menu – Lower Case

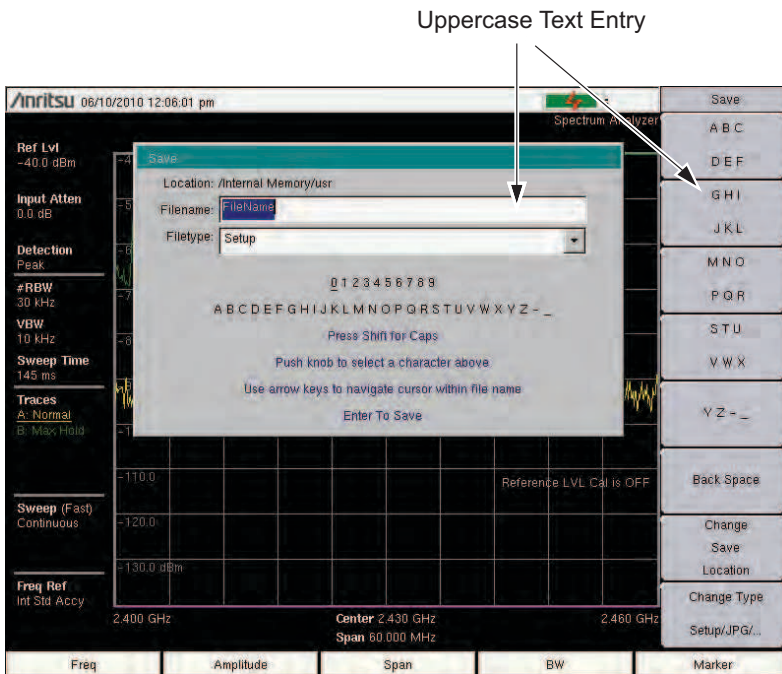
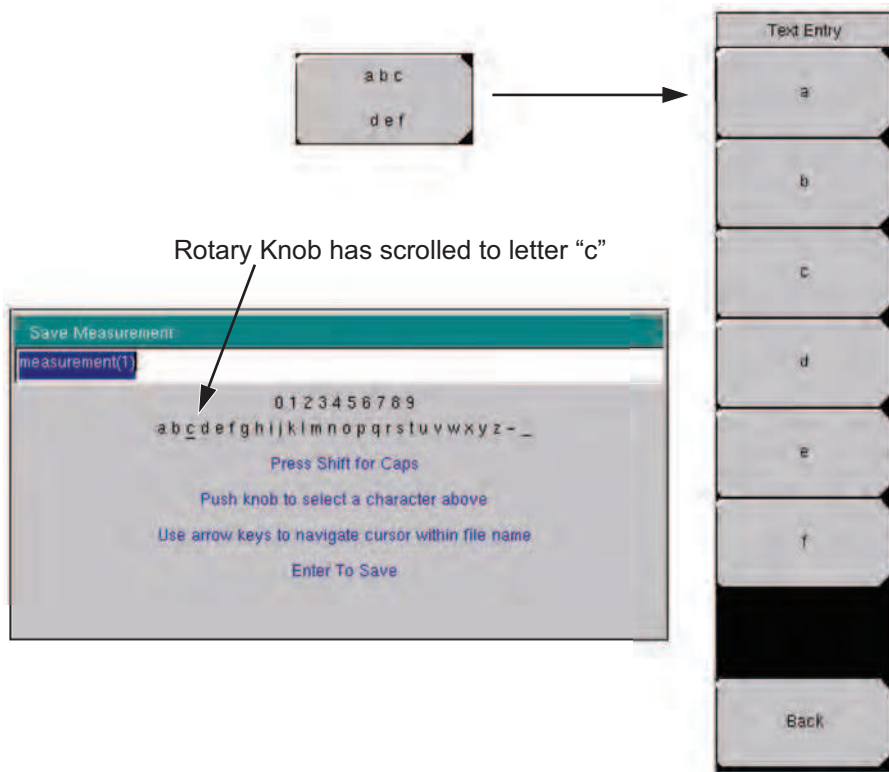

Figure 2-8. Text Entry Menu – Upper Case



**Figure 2-9.** Text Entry Menu – Selecting Characters

## 2-10 Test Panel Connectors

The test panel connector is shown in [Figure 2-10](#) and are described in the following text.

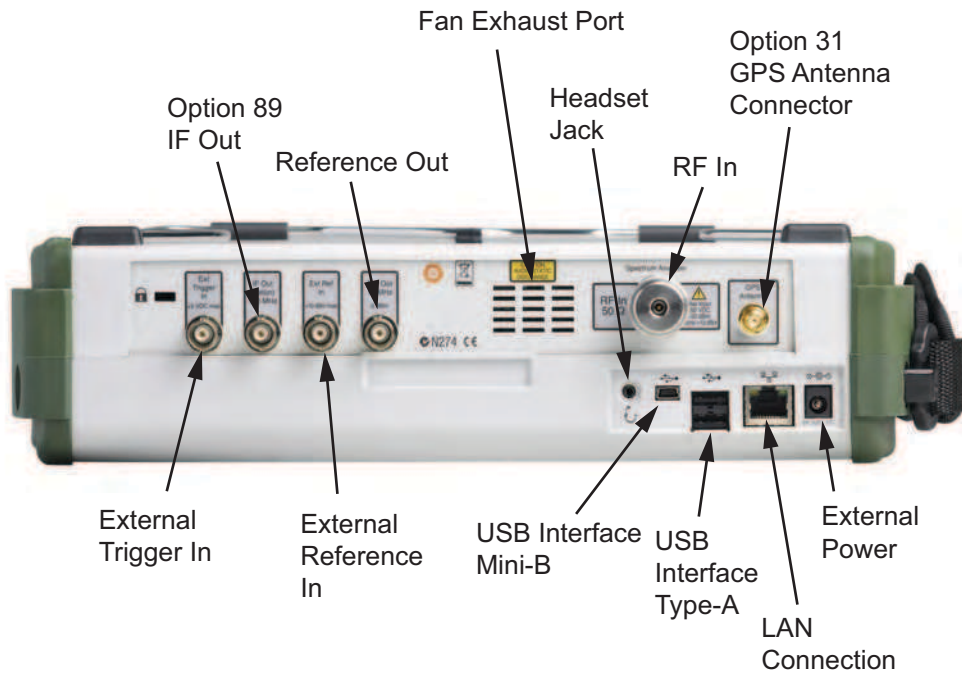

**Figure 2-10.** Test Panel Connectors for MS272xC

### External Power

The external power connector is used to power the unit and for battery charging. Input is 12 VDC to 15 VDC at up to 5.0 A. A green flashing indicator light near the power switch shows that the instrument battery is being charged by the external charging unit. The indicator is steadily illuminated when the battery is fully charged.

**Warning** When using the AC-DC Adapter, always use a three-wire power cable that is connected to a three-wire power line outlet. If power is supplied without grounding the equipment in this manner, then the user is at risk of receiving a severe or fatal electric shock.

### LAN Connection

The RJ-45 connector is used to connect the Spectrum Master to a local area network. Integrated into this connector are two LEDs. The amber LED shows the presence of a 10 Mbit/s LAN connection when on, and a 100 Mbit/s LAN connection when off. The green LED flashes to show that LAN traffic is present. For additional information about the LAN connection, Ethernet connection, and DHCP, refer to [Appendix C, “Ethernet Configuration”](#).

### USB Interface – Type A

The MS272xC Spectrum Master can also be a USB Host and allow various USB Flash Memory devices to be connected to the instrument for storing measurements, setups, and files.

### USB Interface – Type Mini-B

The USB 2.0 interface can be used to connect the MS272xC Spectrum Master directly to a PC. The first time the MS272xC is connected to a PC, the normal USB device detection by the computer operating system will take place. The CD-ROM that shipped with the instrument contains a driver for Windows XP that is installed when Master Software Tools is installed. Drivers are not available for earlier versions of the Windows operating system. During the driver installation process, place the CD-ROM in the computer drive and specify that the installation wizard should search the CD-ROM for the driver.

**Note**

For proper detection, Master Software Tools should be installed on the PC prior to connecting the Spectrum Master to the USB port.

### Headset Jack

The headset jack provides audio output from the built-in AM/FM/SSB demodulator for testing and troubleshooting wireless communication systems. The jack accepts a 2.5 mm 3-wire miniature phone plug such as those commonly used with cellular telephones.

### Ref Out

The External Reference Out port is a BNC female connector that provides 10 MHz at 0 dBm.

### Ext Ref In

The External Reference In port is a BNC female connector that provides for input of an external frequency reference.

### IF Out 140 MHz (Option 89)

BNC connector for Zero Span 140 MHz IF Output with Option 89.

### Ext Trigger In

A TTL signal that is applied to the External Trigger female BNC input connector causes a single sweep to occur. In the Spectrum Analyzer mode, it is used in zero span, and triggering occurs on the rising edge of the signal. After the sweep is complete, the resultant trace is displayed until the next trigger signal arrives.

### RF In

50  $\Omega$  Type-N connector (MS2722C, MS2723C, MS2724C) or a 50  $\Omega$  Type-K male ruggedized connector (MS2725C, MS2726C).

### GPS Antenna Connector (Option 31)

The GPS antenna connection on the Spectrum Master is type SMA(F). Selectable +3 VDC or +5 VDC antenna power.

## 2-11 Symbols and Indicators

The following symbols and indicators convey the instrument status or condition on the display.

### Cal Status On:

The Spectrum Master has been calibrated with discrete Open, Short, and Load components.

### Cal Status Off:

The Spectrum Master has not been calibrated.

### Battery Symbol:

The battery symbol above the display indicates the charge remaining in the battery. The colored section inside the symbol changes size and color with the charge level.



**Figure 2-11.** Battery Status

**Green:** Battery is 30% to 100% charged

**Yellow:** Battery is 10% to 30% charged

**Red:** Battery 0% to 10% charged

**Lightning Bolt:** Battery is being charged (any color symbol)

When the battery is charging, either from the AC-DC Adapter (40-168-R) or the 12 Volt DC adapter (806-141-R), the symbol changes to that shown in [Figure 2-12](#):



**Figure 2-12.** Battery Charging Status

The Battery Charge LED (refer to [Figure 2-2 on page 2-3](#)) flashes when the battery is charging, and remains on steady when the battery is fully charged.

**Caution** Use only Anritsu-approved batteries, adapters, and chargers with this instrument.

The battery symbol is replaced by a red plug body to indicate that the instrument is running from external power and is not charging the battery (or to indicate that the battery is not present). When the external AC adaptor is connected, the battery automatically receives a charge, and the battery symbol with the lightning bolt is displayed (Figure 2-12). When the battery is not installed, the red plug body is displayed, as shown in Figure 2-13, and the red Fault LED will be on. If the battery is installed but has lost communications with the instrument, then the battery charge indicator will not be shown.



---

**Figure 2-13.** Battery Not Installed

### Hold

The Spectrum Master is on hold. To resume sweeping, toggle from Hold to Run in the Sweep menu.

### Single Sweep

Single Sweep is selected. Press Continuous sweep to resume sweeping.



## 2-12 Firmware Overview

### Main Menu Keys

The Spectrum Master menu-driven interface is easy to use and requires little training. The 5 Main Menu keys are located below the measurement display. These 5 keys are used to list function-specific menus in the active menu (submenu labels). These Main Menu keys vary in function based on the selected mode of operation (**Shift, Mode** (9)). Refer to [“Mode Selector Menu” on page 2-6](#) for more information on changing the instrument mode. [Table 2-1](#) lists from left to right the Main Menu Key labels for each mode of instrument operation.

**Table 2-1.** Mode-Dependent Main Menu Keys Located Below Measurement Display

Mode	Key 1	Key 2	Key 3	Key 4	Key 5
Spectrum Analyzer	Freq	Amplitude	Span	BW	Marker
Interference Analysis	Freq	Amplitude	BW	Measurements	Marker
Channel Scanner	Scanner	Amplitude	Custom Scan	Measurements	
Power Meter	Freq	Amplitude	Average		Limits
High Accuracy Power Meter		Amplitude	Average	Zero/Cal	Limit
GSM/GPRS/EDGE	Freq	Amplitude	Setup	Measurements	Marker
W-CDMA/HSDPA	Freq	Amplitude	Setup	Measurements	Marker
TD-SCDMA/HSDPA	Freq	Amplitude	Setup	Measurements	
CDMA	Freq	Amplitude	Setup	Measurements	Marker
EV-DO	Freq	Amplitude	Setup	Measurements	Marker
LTE	Freq	Amplitude	Setup	Measurements	Marker
Fixed WiMAX	Freq	Amplitude	Setup	Measurements	
Mobile WiMAX	Freq	Amplitude	Setup	Measurements	Marker
DVB-T/H	Frequency	Amplitude	Setup	Measurements	Marker

### Submenu Keys

The 8 submenu keys are located to the right of the measurement display. They change function depending upon the current mode and current menu selection. The current submenu title is shown at the top of the active function block (submenu keys labels). Refer to [Figure 2-2 on page 2-3](#).

# Chapter 3 — Quick Start Guide

## 3-1 Introduction

This chapter provides a brief overview of the Anritsu MS272xC Spectrum Master. The intent of this chapter is to provide a starting point for making basic measurement setups. This chapter describes setup, configure frequency, bandwidth, and amplitude before configuring your measurement setups. After measurements are taken, refer to section “[Managing Files](#)” on page 4-1 for a description of saving, recalling, and deleting measurement files. For more detailed information about specific measurements, refer to the measurement descriptions in the measurement guides for the specific instrument mode and analyzer technology (such as Spectrum Analyzer, WiMAX, or 3GPP). Refer to [Appendix A, “Measurement Guides”](#), for a list of these measurement guides and their Anritsu part numbers.

The Spectrum Analyzer Measurement Guide includes sections that describe resolution bandwidth, video bandwidth, sweep, and attenuator functions. For example, in the Spectrum Master, Resolution Bandwidth is determined by the intermediate frequency (IF) filter bandwidth. The spectrum analyzer traces the shape of the IF filter as it tunes past a signal. If more than one IF filter is used in a spectrum analyzer, then the narrowest one dominates and is considered the resolution bandwidth. [Figure 3-1](#) is an example of a spectrogram display.

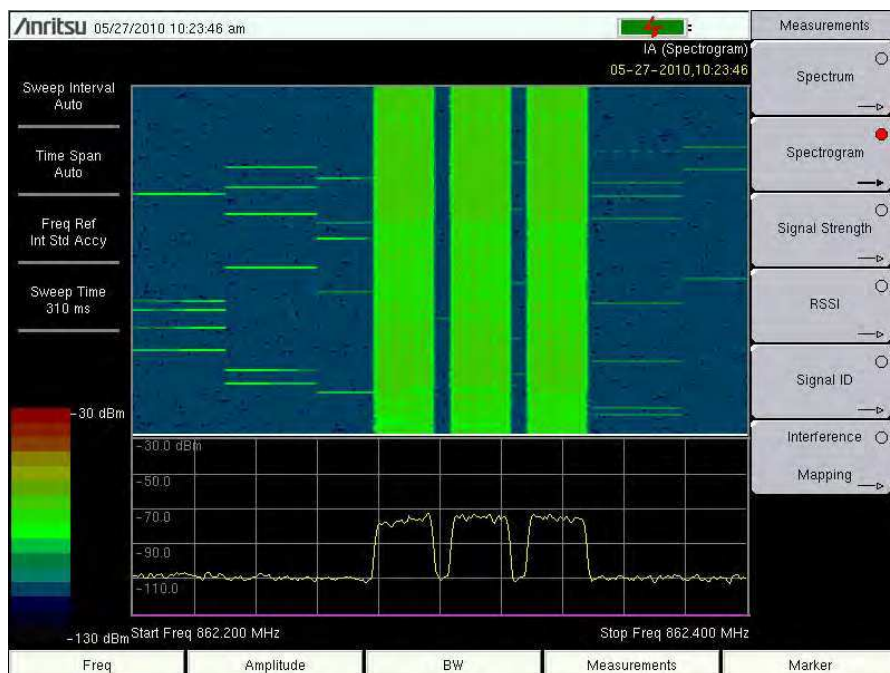

**Figure 3-1.** Spectrogram Example

## 3-2 Measurement Setup

### Connect the Input Source

Connect the input signal or antenna to the appropriate test connector on the top of the instrument. For connector descriptions, refer to [Figure 2-10 on page 2-12](#).

### Editing and Entering Values

- Parameter values that are ready for editing are displayed in red on the submenu key. After changing the value, press **Enter** to set the new value.
- Some submenu keys have toggled parameter values (On / Off, Low / High). On these submenu keys, the current value is underlined. Press the submenu key to toggle the value.
- Use the arrow keys, numeric keypad, or rotary knob to change submenu key values, to select list box options, or to enter filenames.

### Selecting the Analyzer Mode

1. Press the **Shift** key followed by pressing the **Mode** (9) key on the numeric keypad to open the Mode Selector list box (refer to section [“Mode Selector Menu” on page 2-6](#)).
2. Use the directional arrow keys or the rotary knob to highlight the desired mode, and press the **Enter** key or the rotary knob to select.

## 3-3 Set the Measurement Frequency

### Using Start and Stop Frequencies

1. Press the **Freq** main menu key.
2. Press the Start Freq submenu key.
3. Enter the desired start frequency. When entering a frequency by using the keypad, the submenu key labels change to frequency units: GHz, MHz, kHz, and Hz. Press the appropriate unit key. Pressing the **Enter** key has the same affect as pressing the MHz submenu key.
4. Press the Stop Freq submenu key.
5. Enter the desired stop frequency.

### Entering Center Frequency

1. Press the **Freq** main menu key.
2. Press the Center Freq submenu key.
3. Enter the desired center frequency by using the keypad, the arrow keys, or the rotary knob. When entering a frequency by using the keypad, the submenu key labels change to frequency units: GHz, MHz, kHz, and Hz. Press the appropriate unit key. Pressing the **Enter** key has the same affect as pressing the MHz submenu key.

The current setting is shown at the top of the instrument settings summary column on the left side of the measurement display (refer to [Figure 2-6, “Spectrum Analyzer Display” on page 2-8](#)).

### Selecting Signal Standard

1. Press the **Freq** main menu key.
2. Press the Signal Standard submenu key. The Signal Standards dialog opens.
3. Highlight a signal standard and press **Enter** or the rotary knob to select.
4. Press the Channel submenu key to change the channel value in the Channel Editor.

<b>Note</b> The signal standards list can be updated via Master Software Tools.
---

### Setting Measurement Frequency Bandwidth

#### Spectrum Analyzer and Interference Analysis Mode

1. Press the **BW** main menu key to display the BW menu.
  - Press the RBW or the VBW submenu key (or both) to manually change values.
  - Set RBW and VBW automatically by pressing the Auto RBW submenu key or the Auto VBW submenu key.
2. Press the VBW/Average Type submenu key to toggle between Linear averaging (arithmetic mean) and Logarithmic averaging (geometric mean).
3. Press the RBW/VBW submenu key to change the ratio of resolution bandwidth to video bandwidth.
4. Press the Span/RBW submenu key to change the ratio of span width to resolution bandwidth.

## 3-4 Set the Amplitude

Press the **Amplitude** main menu key to display the Amplitude menu.

### Setting Amplitude Reference Level and Scale

#### Spectrum Analyzer and Interference Analysis Modes

**Note** To change the current measurement units, press the Units submenu key and select the required units from the submenu keys that are presented. Press the Back submenu key to return to the Amplitude menu.

1. Press the Reference Level submenu key and use the **Up/Down** arrow keys or the keypad to change the reference level. Press **Enter** to set the reference level value.
2. Press the Scale submenu key and use the **Up/Down** arrow keys or the keypad to enter the desired scale. Press **Enter** to set the scale value.

**Note** The Scale parameter cannot be changed when linear units are selected (Watts or Volts). Press the Amplitude submenu key and select Auto Atten coupling of the attenuator setting and the reference level to help ensure that harmonics and spurs are not introduced into the measurements. Attenuator Functions are described in the Spectrum Analyzer Measurement Guide.

### Setting Amplitude Range and Scale

**Note** This setting applies to most demodulator modes of instrument operation. The Spectrum Analyzer mode has no equivalent to Auto Range. For other analyzer modes, consult the individual measurement guides. Refer to [Appendix A, "Measurement Guides"](#).

1. Press the Adjust Range submenu key to set an optimal reference level based on the measured signal.

**Note** To have the instrument continually set the optimal reference level, press the Auto Range submenu key so that On is selected.

2. Press the Scale submenu key.
3. Enter the desired scale units by using the keypad, the arrow keys, or the rotary knob. Press the **Enter** key to set. The y-axis scale is automatically renumbered.

## Reference Level Offset for External Loss or External Gain

To obtain accurate measurements, compensate for any external attenuation or gain by using the RL Offset submenu. The compensation factor is in dB. External attenuation can be created by using an external cable or an external high power attenuator, external gain is typically from an amplifier.

To adjust the reference level for either gain or loss, press the RL Offset submenu key and enter a positive dB value and then press the appropriate submenu key (dB External Gain or dB External Loss). The new RL Offset value will be displayed on the instrument and reference level is adjusted.

## 3-5 Set the Span

### Spectrum Analyzer, Interference Analysis, and Power Meter Modes

1. Press the **Span** main menu key or press the **Freq** main menu key followed by the **Span** submenu key.
2. To select full span, press the **Full Span** submenu key. Selecting full span overrides any previously set Start and Stop frequencies.
3. For a single frequency measurement, press the **Zero Span** submenu key.

**Note**

To quickly move the span value up or down, press the Span Up 1-2-5 or Span Down 1-2-5 submenu keys. These keys facilitate a zoom-in, zoom-out feature in a 1-2-5 sequence.

## 3-6 Setting Up Limit Lines

Press the **Shift** key then the **Limit** (6) key on the numeric keypad to display the Limit menu.

### Simple Limit Line

#### Spectrum Analyzer and Interference Analysis Modes

1. Press the **Shift** key and then the **Limit** (6) key.
2. Press the Limit (Upper / Lower) submenu key to select the desired limit line, Upper or Lower.
3. Activate the selected limit line by pressing the On Off submenu key so that On is underlined.
4. Press the Limit Move submenu key to display the Limit Move menu. Press the Move Limit submenu key to change the dBm level of the limit line.
5. Press the Back submenu key to return to the Limit menu.
6. If necessary, press the Set Default Limit submenu key to redraw the limit line in view.

### Limit Line Envelope

#### Spectrum Analyzer and Interference Analysis Modes

##### Using Limit Envelope:

1. Press the **Shift** key and then the **Limit** (6) key.
2. Press the Limit (Upper / Lower) submenu key to select the desired limit line, Upper or Lower.
3. Press the Limit Envelope submenu key to display the Limit Envelope menu.
4. Press the Create Envelope submenu key to create an envelope around the measurement.
5. Press Upper Points or Lower Points submenu key to change the number of segments in the envelope.
6. Press the Upper Shape or Lower Shape submenu key to toggle between square and sloped limit envelope.
7. Adjust the Upper or Lower Offset to move the limit line closer to (a smaller value) or further away from the trace.

## Complex Limit Lines

### Spectrum Analyzer and Interference Analysis Modes

Figure 3-2 shows an example of a complex limit line. Limits are set to 12 dB between 1000 MHz and 1400 MHz, and are set to 15 dB between 1600 MHz and 2000 MHz. The center frequency is set to 1.11 MHz and set the span to 200 kHz. After the right half of the limit line was completed, the left half of the limit line was built by pressing the Limit Advanced submenu key and then pressing the Limit Mirror submenu key.

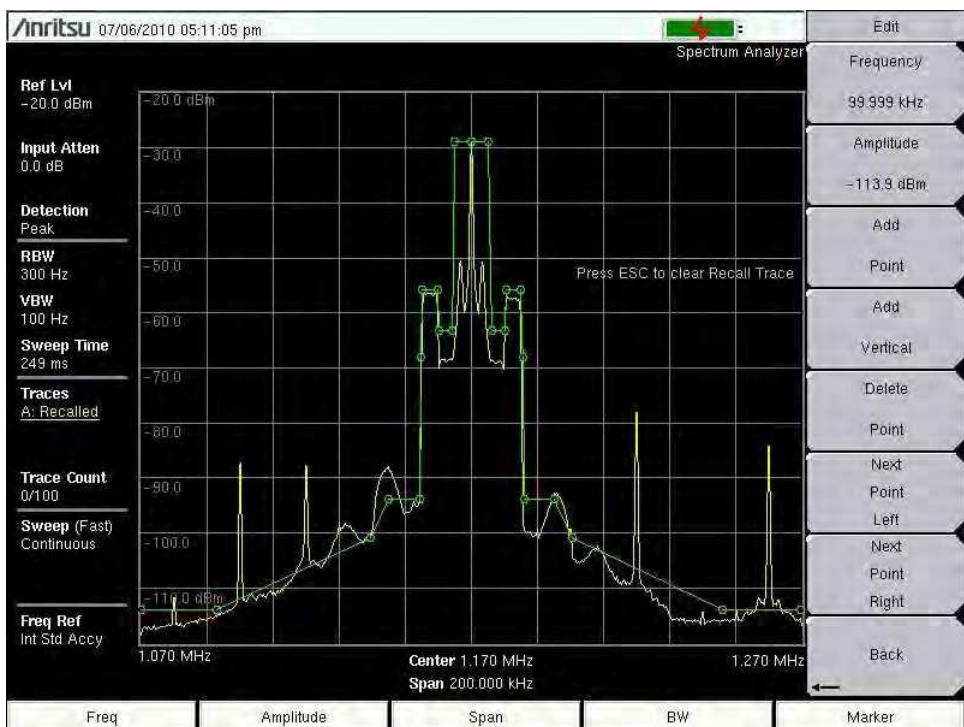

Figure 3-2. Complex Limit Line Example



### 3-7 Setting Up Markers

Press the **Marker** main menu key to display the Marker menu. Refer to [Figure 3-3](#).

#### Selecting, Activating, and Placing a Marker

1. Press the Marker 1 2 3 4 5 6 submenu key so that the desired marker number is underlined. Each press of the Marker 1 2 3 4 5 6 submenu key toggles to the next higher number (cycling from 6 back to 1 again). Press **Shift**, then the Marker 1 2 3 4 5 6 submenu key to cycle backward through the marker list.
2. Press the On Off submenu key so that On is underlined. The selected marker is displayed in red, ready to be moved.
3. Use the rotary knob to place the marker on the desired frequency.
4. Repeat [Step 1](#) and [Step 2](#) to activate and move multiple markers.

#### Selecting, Activating, and Placing a Delta Marker:

1. Press the Marker 1 2 3 4 5 6 submenu key so that the desired delta marker number is underlined.
2. Press the Delta On Off submenu key so that On is underlined. The selected marker is displayed in red, ready to be moved.
3. Use the rotary knob or the numeric keypad to place the delta marker on the desired offset frequency from the associated reference marker.
4. Repeat [Step 1](#) and [Step 2](#) to activate and move multiple markers.

#### Viewing Marker Data in a Table Format

1. Press the More submenu key.
2. Press the Marker Table On Off submenu key so that On is underlined. All markers and delta marker data are displayed in a table under the measurement graph.

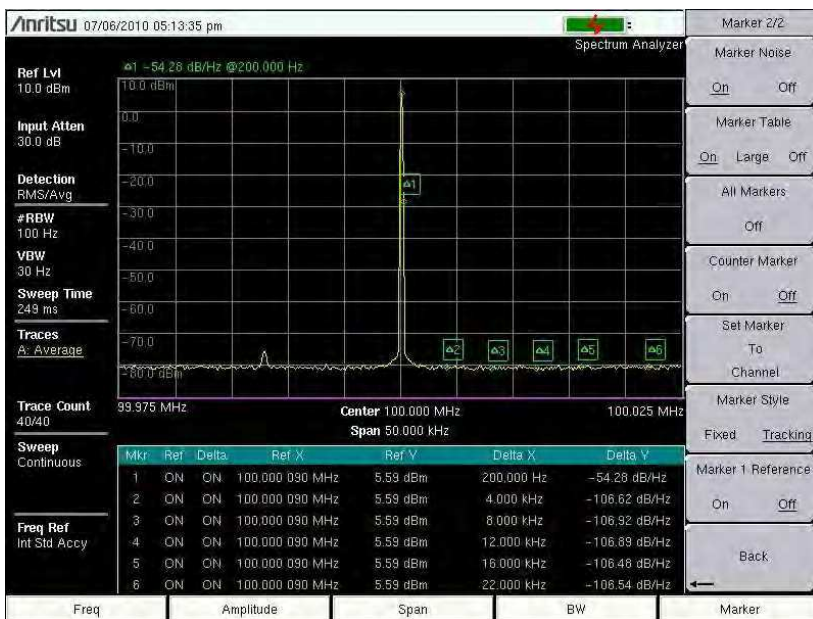

Figure 3-3. Six Noise Markers

## 3-8 Selecting a Measurement Type

1. Change the measurement mode (if required). Press **Shift** then **Mode** (#9).
2. Select the measurement type. Press **Shift** then **Measure** (#4). Select the appropriate measurement type with the submenu key.

## 3-9 Saving Measurements

1. Press **Shift** then **File** (#7).
2. Press the Save Measurement submenu key.
3. Press the Change Save Location submenu key and set the current location to be the USB flash drive or internal memory, and then press **Set Location**.
4. Press Change Type (Setup/JPG/...) and select Measurement.
5. Enter the file name using the letter key and press **Enter**.

Refer to [Chapter 4, “File Management”](#) for additional information.

## 3-10 Master Software Tools

Anritsu Master Software Tools is a Microsoft Windows compatible program for transferring and editing saved measurements, markers, and limit lines to a PC. Refer to [Chapter 7, “Master Software Tools”](#) for an overview of MST.



# Chapter 4 — File Management

## 4-1 Introduction

This chapter will review the file management features of the Spectrum Master and detail the **File** menu. The submenus under this menu allow the user to save, recall, copy, and delete files in internal memory or an external USB flash drive.

## 4-2 Managing Files

Press the **Shift** key then the **File** (7) key on the numeric keypad to list the **File** menu. Follow the additional steps below.

**Note**

When navigating through the **File** menu, pressing the **Esc** key will return to the previous menu.

### Save Files

#### Set the Save Location

Press **Save** then the **Change Save Location** submenu keys and select the location to save files. You can save files to the internal memory or to an external USB flash drive. You can also create new folders. If an external USB flash drive is connected or disconnected, press **Refresh Directories** to update the location tree. Press the **Set Location** key to store the save location.

#### Save Measurement As

The **Save Measurement As** key is used to quickly save measurements with a specific file name. The Spectrum Master saves the measurement with the latest file name that was used to save a measurement and with a number that is automatically incremented and appended to the end of the file name. For instance, if the last measurement was saved with the name **Site 1 Trace**, **Save Measurement As** saves the next measurement as **Site 1 Trace\_#1**, **Site 1 Trace\_#2**, etc. The file name used can be changed using the [“Save Menu” on page 4-8](#).

#### Save a Measurement

Press the **Save Measurement** key and enter the name for the measurement file. The file type will default to measurement and the appropriate extension will be added based on the current measurement mode.

#### Save a Setup

Press the **Save** submenu key, type a name for the setup file, confirm that the file type is **Setup** using the **Change Type** key and press **Enter** to save.

#### Save a Measurement Screen as JPEG

Press the **Save** submenu key, type a name for the JPEG file, confirm that the file type is **Jpeg** using the **Change Type** key and press **Enter** to save.

## Recall Files

The recall menu enables you to view all the Measurement and Setup files in the internal memory and external USB flash drive.

You can sort the recall menu by name, date, or type. You can also select to view only measurement files or setup files by pressing **File Type** on the Recall dialog box and selecting the file type you want to view.

### Recall a Measurement

From the **File** menu, press the Recall Measurement submenu key, select the measurement with the rotary knob or the **Up/Down** arrow keys and press **Enter**.

### Recall a Setup

Press the Recall submenu key. Confirm that the file type is **Setup** or **All** using the **File Type** key. Select the setup file (.stp) with the rotary knob or the **Up/Down** arrow keys and press **Enter**.

## Recall Dialog Box

The Recall dialog box (Figure 4-1) will open previously saved measurements and setups. See the “[Recall Menu](#)” on page 4-11 for additional information.

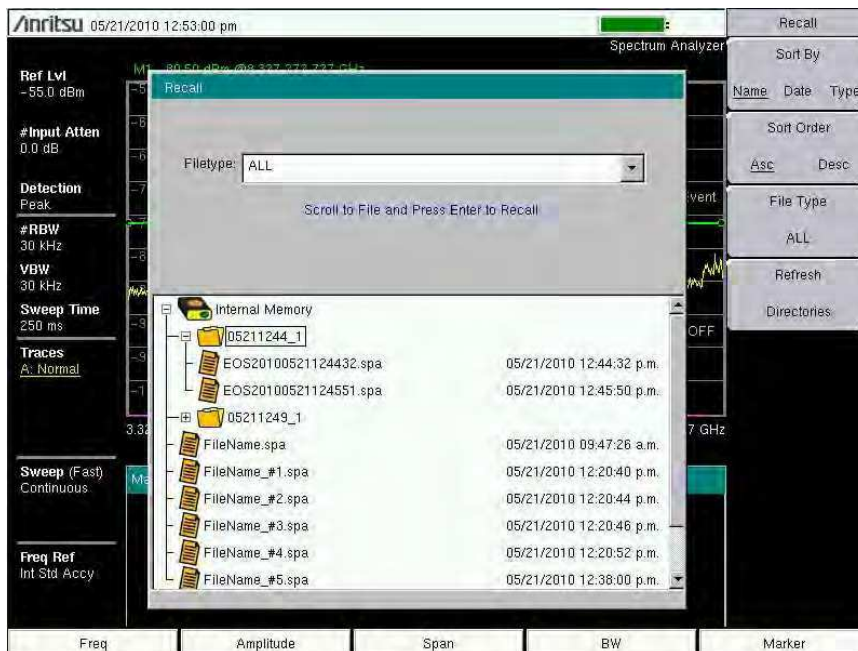
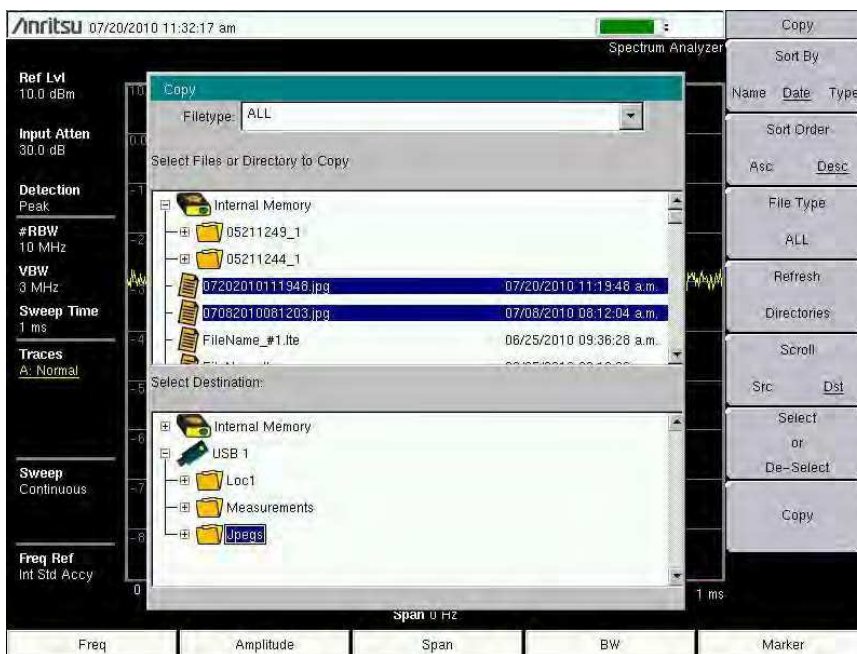

Figure 4-1. Recall Dialog Box

## Copying Files

The steps below detail copying a file from internal memory to an external flash drive. Select the files to copy in the top window and the location for the files to be copied to in the bottom window (Figure 4-2). Refer to the “Copy Menu” on page 4-12 for additional information.

1. Insert a USB drive into either USB Type A port of the Spectrum Master.
2. From the **File** main menu, press the **Copy** submenu key. The Copy submenu and Copy dialog box are displayed.
3. Select the file(s) to copy. To select multiple files, highlight the first then press the **Select** or **De-Select** key to keep the file selected. The file will be outlined in blue (Figure 4-2). Repeat with all the files to copy.



**Figure 4-2.** Two .jpg Files Ready to Copy from Internal Memory to the USB Drive, Jpeg Folder

**Note** Use the **Left/Right** arrow keys to Collapse/Expand folders.

- To display files within a folder, select the folder and press the **Enter** key or the **Right** arrow key. The + symbol indicates additional files or folders with the folder (Figure 4-3). To expand the + symbol, highlight the folder and press the **Right** arrow key.

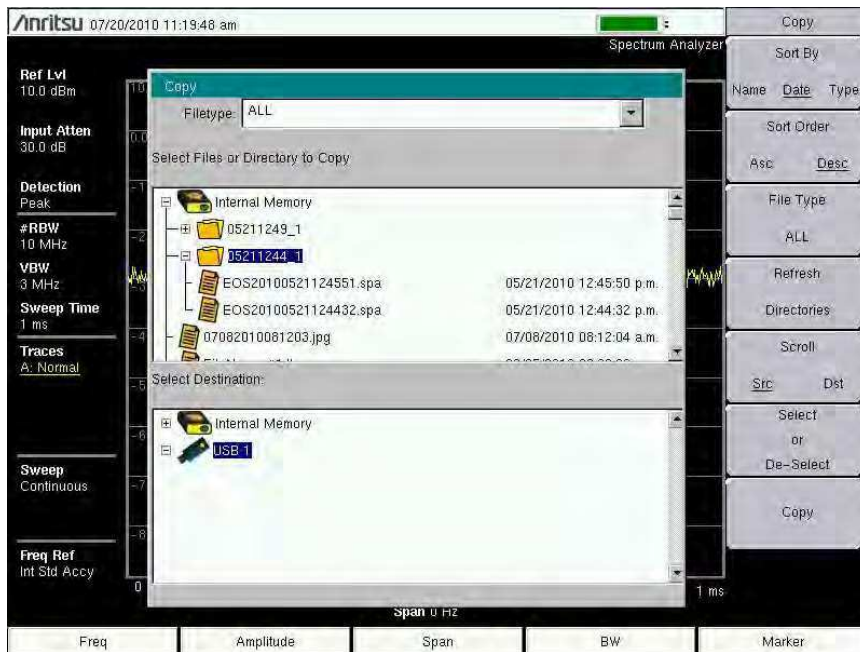

**Figure 4-3.** Expanded Folder

- Press the **Scroll** key and highlight the USB drive in the lower window using the **Up/Down** arrow keys. The **Scroll** submenu key toggles between **Src** (top window) and **Dst** (bottom window).
- Select the copy location on the USB drive.
- Press the **Copy** key to copy the files to the USB drive.

## Deleting Files

### Delete a Selected File or Files

Press the Delete submenu key. Highlight the file to be deleted with the **Up/Down** arrow keys. Press the Select or De-Select key. The file will be highlighted in blue when selected. Press the Delete key and **Enter** to delete the selected file.

### Delete Dialog Box

Press the Delete submenu key to open the Delete dialog box (Figure 4-4). The submenus allow sorting by file type, name and saved date. See the “Delete Menu” on page 4-13 for additional information.

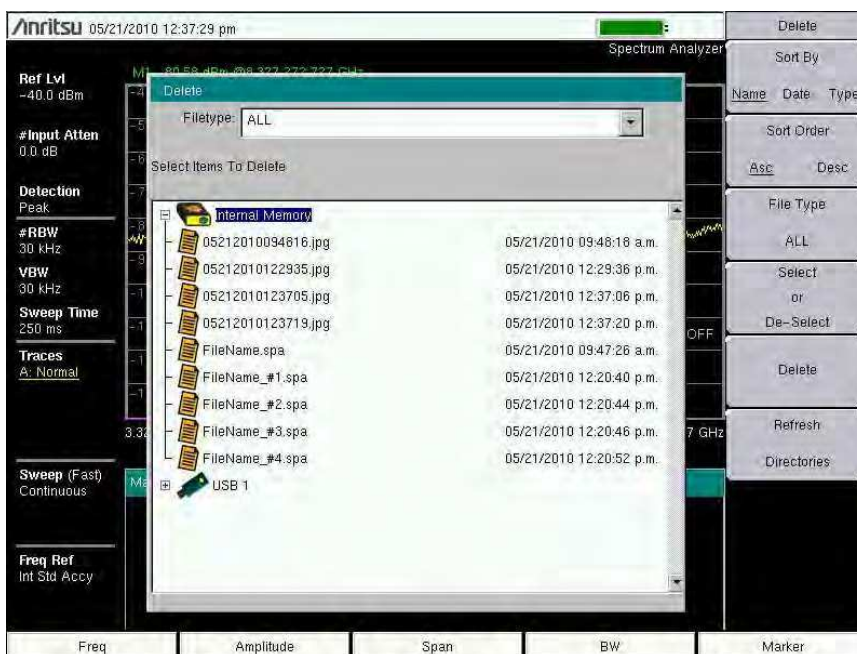

Figure 4-4. Delete Dialog Box



### 4-3 File Menu Overview

Open this menu by pressing the **Shift** key, then the **File** (7) key.

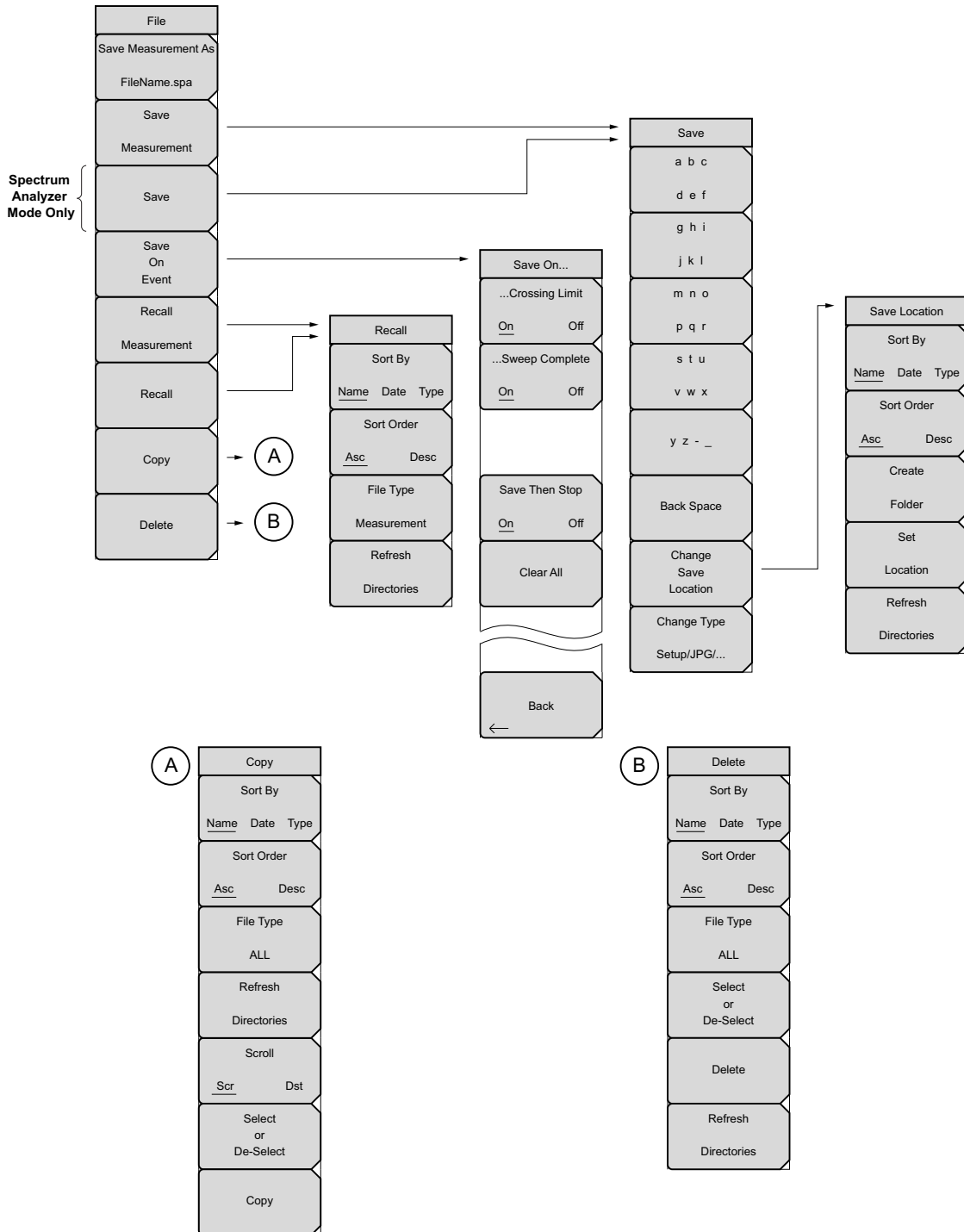

Figure 4-5. File Menu

## 4-4 File Menu

Key Sequence: **File**

File	<p><b>Save Measurement As:</b> This key will save the current setup with a user defined file name. The default file name is changed using the Save submenu. To change the default file name, press the Save Measurement submenu key to open the Save dialog box. Enter the new measurement filename with the letter keys. Refer to <a href="#">“Save Menu” on page 4-8</a>. Press <b>Enter</b> to save the name and return to the File menu. The Save Measurement As submenu key displays the new entered name appended with <code>_#1.spa</code>. After a few seconds the screen with return to File menu. Press the Save Measurement As key again and the new file name will be used. Measurement files names have a <code>.spa</code> extension.</p> <p><b>Save Measurement:</b> Press this submenu key to display the <a href="#">“Save Menu” on page 4-8</a> and Save dialog box. Measurements can be saved to internal memory or to a USB flash drive. The saved measurement can be named using the text entry keys. By default, measurements are saved in a directory named <code>/user</code> to internal memory. The save destination is set with the <a href="#">“Save Location Menu” on page 4-9</a>.</p> <p><b>Save:</b> Press this submenu key to display the <a href="#">“Save Menu” on page 4-8</a>. Measurements can be saved to internal memory or to a USB flash drive. The saved setup, measurement or JPEG file can be named by using the text entry keys. By default, measurements are saved in a directory named <code>/user</code> to internal memory. The save destination is set with the <a href="#">“Save Location Menu” on page 4-9</a>.</p> <p><b>Save on Event (Spectrum Analyzer mode only):</b> Press this submenu key to display the <a href="#">“Save On Event Menu” on page 4-10</a>.</p> <p><b>Recall Measurement:</b> Press this submenu key to display the <a href="#">“Recall Menu” on page 4-11</a>. This menu is for recalling measurements from internal memory or a USB flash drive.</p> <p><b>Recall:</b> Press this submenu key to display the <a href="#">“Recall Menu” on page 4-11</a>. This menu is for recalling measurement or setup data from internal memory or a USB flash drive.</p> <p><b>Copy:</b> Press this submenu key to display the <a href="#">“Copy Menu” on page 4-12</a>. This submenu is for copying files or folders from internal memory or a USB flash drive.</p> <p><b>Delete:</b> Press this submenu key to display the <a href="#">“Delete Menu” on page 4-13</a> and a selection box that shows the setup and measurement names, the type and the date and time that the information was saved. Use the rotary knob or the <b>Up/Down</b> arrow keys to highlight the file that is to be deleted and press the Delete submenu key, then <b>Enter</b>. Press the <b>Esc</b> key to cancel the operation. Note that deleted files can not be recovered.</p>
Save Measurement As	
FileName.spa	
Save	
Measurement	
Save	
Save On Event	
Recall	
Measurement	
Recall	
Copy	
Delete	

**Figure 4-6.** File Menu

### Save Menu

Key Sequence: **File** > Save

Save	<p><b>Text Entry Keys:</b> The top 5 keys are for text entry. The submenu keys for Text Entry displays the characters (alphabet, hyphen, and underscore). Press the a b c / d e f submenu key (for example) to open another submenu with a separate key for each of these letters. Characters can be entered by using the rotary knob or by using the submenu keys.</p> <p>The rotary knob scrolls through the characters in a pop-up window and pressing the rotary knob enters a character. The menu returns to the complete character set after each individual letter is entered.</p> <p>Use the arrow keys to navigate within a name or character string. Use the <b>Shift</b> key for capital letters. Press the <b>Enter</b> key or the rotary knob to finalize a text entry.</p> <p><b>Back Space:</b> Use this key to delete a file name highlighted in blue or delete individual characters.</p> <p><b>Change Save Location:</b> Press this submenu key to open the <a href="#">"Save Location Menu"</a>.</p> <p><b>Change Type:</b> Press this submenu key to select what type of file is saved. The options are the Measurement, Setup, or Jpeg. The file type can be changed with the <b>Up/Down</b> keys or the rotary knob.</p> <p><b>Setup (.stp):</b> Setup files contain basic instrument information, measurement mode setup details, measurement marker data, and limit data.</p> <p><b>Measurement (.spa):</b> Contains the measurement data and opens with Master Software Tools.</p> <p><b>Jpeg (.jpg):</b> Jpeg files contain a screen capture of the display.</p> <p><b>Limit Lines (.lim):</b> The Limit line file contains limit line data details.</p>
a b c d e f	
g h i j k l	
m n o p q r	
s t u v w x	
y z - _	
Back Space	
Change Save Location	
Change Type	
Setup/JPG/...	

Figure 4-7. Save Menu

## Save Location Menu

Key Sequence: **File** > Save > Change Save Location

Save Location	<p>This menu and dialog box is used to create folders and select where the Spectrum Master will save the current file. Select folders or drives with the <b>Up/Down</b> keys or the rotary knob.</p> <p>Note: Only folders (not files) are visible in the Save Location dialog box. To view files, use the <a href="#">“Recall Menu” on page 4-11</a>.</p> <p><b>Sort By:</b> Press this submenu key to sort the folders by Name, Type, or Date.</p> <p><b>Sort Order:</b> Displays the folder names in ascending or descending order .</p> <p><b>Create Folder:</b> This key will create a new folder in the highlighted location or folder. The create directory dialog box will display for naming the folder.</p> <p><b>Set Location:</b> This key will set the current location for saving files and return to the <a href="#">“Save Menu” on page 4-8</a>.</p> <p><b>Refresh Directories:</b> Press this key to update the display.</p>
Sort By	
Name Date Type	
Sort Order	
Asc Desc	
Create	
Folder	
Set	
Location	
Refresh	
Directories	

**Figure 4-8.** Save Location Menu



**Figure 4-9.** Select Save Location Dialog Box

## Save On Event Menu

Key Sequence: **File** > Save On Event

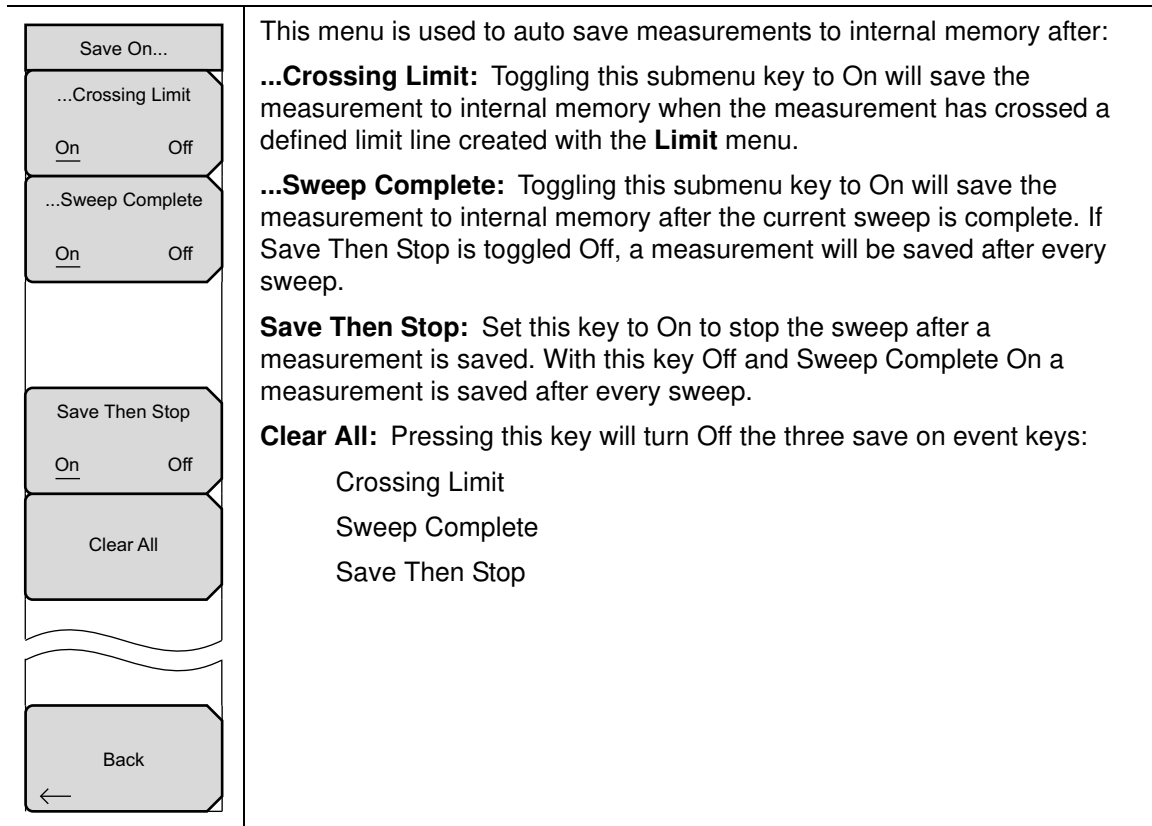

This menu is used to auto save measurements to internal memory after:

**...Crossing Limit:** Toggling this submenu key to On will save the measurement to internal memory when the measurement has crossed a defined limit line created with the **Limit** menu.

**...Sweep Complete:** Toggling this submenu key to On will save the measurement to internal memory after the current sweep is complete. If Save Then Stop is toggled Off, a measurement will be saved after every sweep.

**Save Then Stop:** Set this key to On to stop the sweep after a measurement is saved. With this key Off and Sweep Complete On a measurement is saved after every sweep.

**Clear All:** Pressing this key will turn Off the three save on event keys:

- Crossing Limit
- Sweep Complete
- Save Then Stop

**Figure 4-10.** Save On Menu

## Recall Menu

Key Sequence: **File** > Recall

Recall	<p>This menu and dialog box is used to create folders and select where the Spectrum Master will save the current file. Select folders or drives with the <b>Up/Down</b> keys or the rotary knob.</p> <p><b>Sort By:</b> Press this submenu key to sort file and folders by the file name, by the type of file, or by the date that the file or folder was saved.</p> <p><b>Sort Order:</b> Displays the folder or file in ascending or descending order based on the selection in the Sort By key.</p> <p><b>File Type:</b> Press this submenu key to select what type of file is viewed. The options are the ALL, Measurement, or Setup. The file type can be changed with the <b>Up/Down</b> keys or the rotary knob. Press <b>Enter</b> to make the selection.</p> <p><b>Setup:</b> Setup files contain basic instrument information, measurement mode setup details, measurement marker data, and limit data.</p> <p><b>Measurement:</b> Measurement files contain all of the information in the setup files and the measurement data.</p> <p><b>Limit Lines (.lim):</b> The Limit line file contains limit line data details.</p> <p><b>ALL:</b> Displays all file types.</p> <p><b>Refresh Directories:</b> Press this key to update the display.</p>
Sort By	
Name   Date   Type	
Sort Order	
Asc   Desc	
File Type	
ALL	
Refresh	
Directories	

**Figure 4-11.** Recall Menu

## Copy Menu

Key Sequence: **File** > Copy

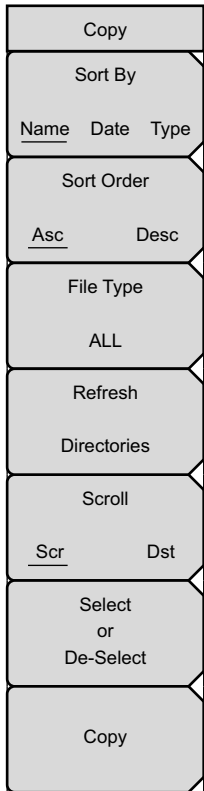

This menu and dialog box is used to copy folders and files. Select folders or files with the **Up/Down** keys or the rotary knob. [Figure 4-2 on page 4-3](#) shows the Copy dialog box with two Jpeg images selected and ready to be copied to the USB flash drive. Highlight a folder and press **Enter** or the **Right** arrow key to view the contents.

**Sort By:** Press this submenu key to sort file and folder lists by name, by type of file, or by the date that the file was saved.

**Sort Order:** Displays the folder or file in ascending or descending order based on the selection in the Sort By key.

**File Type:** Press this submenu key to select what type of file to view for copying. The options are: ALL, Measurement, Setup, or Jpeg. The file type can be changed with the **Up/Down** keys or the rotary knob. Press **Enter** to make the selection.

**Refresh Directories:** Press this key to update the display.

**Scroll:** Press this submenu key to use the scroll function in the Source Window (Scr - top panel) or Destination Window (Dst - bottom panel). See [Figure 4-2](#).

Note: Previously saved files are not visible in this window.

**Select or De-Select:** Use this key to select or deselect the file(s) or folder(s) to be copied. When selected, a file or folder will be outlined in blue, see [Figure 4-2](#).

**Copy:** Copies the files or folders selected in the top window to the destination selected in the bottom window. A dialog box will display showing when the copying is complete. If a file with the same name exists in the destination folder a warning box will display to allow file overwrite or to cancel.

**Figure 4-12.** Copy Menu

## Delete Menu

Key Sequence: **File** > Delete

Delete	<p>This menu and dialog box is used to delete folders and files. Select folders or files with the <b>Up/Down</b> keys or the rotary knob.</p> <p><b>Sort By:</b> Press this submenu key to sort files and folders by name, by the type of file, or by the date that the file or folder was saved.</p> <p><b>Sort:</b> Displays the folder or file in ascending or descending order based on the selection in the Sort By key.</p> <p><b>File Type:</b> Press this submenu key to select what type of file view for deleting. The options are the ALL, Measurement, Setup, Limit Lines, or Jpeg. The file type can be changed with the <b>Up/Down</b> keys or the rotary knob. Press <b>Enter</b> to make the selection.</p> <p><b>Select or De-Select:</b> Use this key to select or deselect the file(s) or folder(s) to be deleted. When selected, a file or folder will be outlined in blue.</p> <p><b>Delete:</b> Press this key to open the Delete dialog box. Press <b>Enter</b> to delete the selected item or <b>Esc</b> to Cancel.</p> <p><b>Refresh Directories:</b> Press this key to update the display.</p>
Sort By	
Name   Date   Type	
Sort Order	
Asc          Desc	
File Type	
ALL	
Select or De-Select	
Delete	
Refresh Directories	

**Figure 4-13.** Delete Menu





# Chapter 5 — System Operation

## 5-1 Introduction

This chapter reviews the Spectrum Master system operations.

The other menus (Sweep, Measure, Trace, and Limit) are described in the Measurement Guides that are listed in [Appendix A](#).

## 5-2 System Menu Overview

To access the functions under the System menu, press the **Shift** key, then the **System (8)** key.

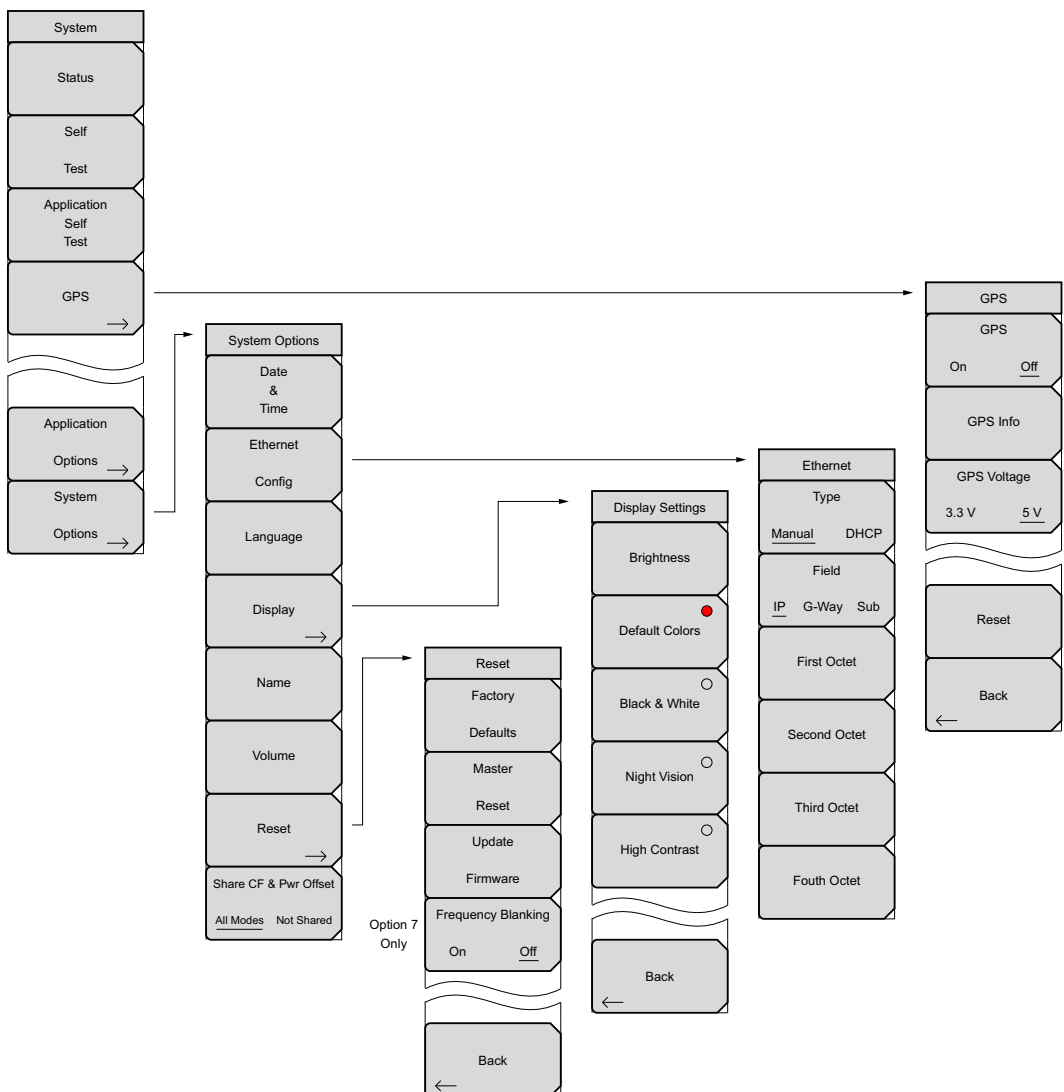

**Figure 5-1.** System Menu Map

## 5-3 System Menu

Key Sequence: **Shift, System** (8)

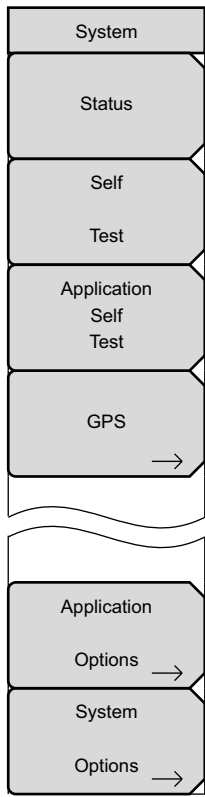

**Status:** Press this submenu key to display the current system status, including the operating system and firmware versions, temperatures, and other details such as current battery information. Press **Esc** or **Enter** to return to normal operation.

**Self Test:** Press this submenu key to initiate a series of diagnostic tests that test the components of the instrument. A display lists the individual tests with a pass or fail indication. Press **Esc** or **Enter** to return to normal operation.

**Application Self Test:** Press this submenu key to initiate a series of diagnostic tests that are related to the performance of the current measurement mode. A display lists the individual tests with a pass or fail indication. Press **Esc** or **Enter** to return to normal operation.

**GPS:** Press this submenu key to open the GSP Menu. Refer to [Chapter 6, “GPS \(Option 31\)”](#) for additional information.

**Application Options:** Submenu keys are specific to each measurement mode. Please refer to a specific Measurement Guide, as listed in [Appendix A](#).

**System Options:** Press this submenu key to open the [“System Options Menu”](#) on page 5-3.

**Figure 5-2.** System Menu

## System Options Menu

Key Sequence: **Shift, System** (8) > System Options

System Options	
Date & Time	<b>Date &amp; Time:</b> Press this submenu key to display a dialog box for setting the current date and time. Use the submenu keys or the <b>Left/Right</b> arrow keys to select the field to be modified. Use the keypad, the <b>Up/Down</b> arrow keys, or the rotary knob to select the date and time. Press <b>Enter</b> to accept the changes, or press the <b>Esc</b> key to return to normal operation without changing anything.
Ethernet Config	<b>Ethernet Config:</b> Press this submenu key to display the Ethernet submenu and to open the Ethernet Editor dialog box to set the IP address of the instrument. For details, refer to section <a href="#">“Ethernet Configuration” on page C-1 in Appendix C, “LAN and DHCP”</a> .
Language	<b>Language:</b> Press this submenu key to open a list box and select a built-in language for the Spectrum Master displays. The languages that are currently available are: English, French, German, Spanish, Japanese, Chinese, Korean, and Italian. In addition, a custom language may be selected if it has been defined by using Master Software Tools and loaded into the Spectrum Master. Two custom languages may be loaded into the instrument via Master Software Tools. If a mode does not have language translations available, then English is the default language. Press <b>Enter</b> to accept the change, or press the <b>Esc</b> key to return to normal operation without changes. In addition, any existing language (except English) may be edited for a better local translation.
Display →	<b>Note:</b> A Factory Default reset ( <b>Esc+On</b> ) will overwrite any custom settings within the Spectrum Master and will require that you reload the custom language files via Master Software Tools.
Name	<b>Display:</b> The Display submenu key opens the <a href="#">“Display Settings Menu” on page 5-4</a> allowing brightness control and the selection of the default color display, black & white display, night vision display, or a high contrast display.
Volume	<b>Name:</b> Press this submenu key to open a dialog box to name the instrument. The Spectrum Master can be named by using the text entry controls as described in section <a href="#">“Text Entry” on page 2-9</a> . Press <b>Enter</b> to save the name.
Reset →	<b>Volume:</b> Press this submenu key to set the speaker volume. The current volume setting is displayed on the screen. Use the keypad, the <b>Up/Down</b> arrow keys, or the rotary knob to change the volume, and press the <b>Enter</b> key to accept the change.
Share CF & Pwr Offset	<b>Reset:</b> Press this submenu key to open the <a href="#">“Reset Menu” on page 5-5</a> .
All Modes    Not Shared	<b>Share CF and Pwr Offset:</b> Select All Modes to have the current center frequency setting and power offset setting carried over when changing measurement modes. Not applicable to measurements which do not have a center frequency setting or measurements where the current center frequency setting is outside the range of the new measurement.

**Figure 5-3.** System Options Menu

## Display Settings Menu

Key Sequence: **Shift, System (8)** > System Options > Display

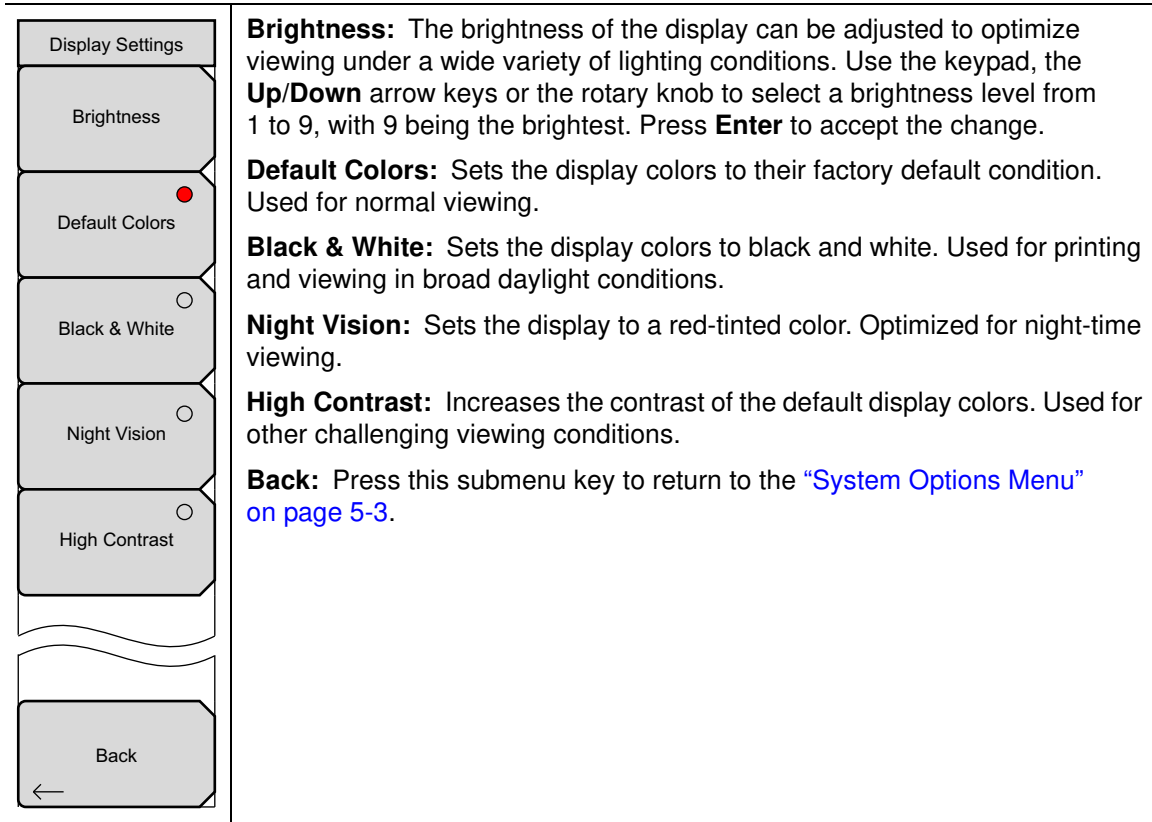

**Brightness:** The brightness of the display can be adjusted to optimize viewing under a wide variety of lighting conditions. Use the keypad, the **Up/Down** arrow keys or the rotary knob to select a brightness level from 1 to 9, with 9 being the brightest. Press **Enter** to accept the change.

**Default Colors:** Sets the display colors to their factory default condition. Used for normal viewing.

**Black & White:** Sets the display colors to black and white. Used for printing and viewing in broad daylight conditions.

**Night Vision:** Sets the display to a red-tinted color. Optimized for night-time viewing.

**High Contrast:** Increases the contrast of the default display colors. Used for other challenging viewing conditions.

**Back:** Press this submenu key to return to the ["System Options Menu"](#) on page 5-3.

**Figure 5-4.** Display Settings Menu

## Reset Menu

Key Sequence: **Shift, System** (8) > System Options > Reset

Reset	<p><b>Factory Defaults:</b> Press this submenu key to restore the Spectrum Master to its factory default parameter values and Mode settings, including Ethernet, language, and brightness settings. Press the <b>Enter</b> key to initiate the reset. The Spectrum Master is automatically rebooted as part of this operation. To return to normal operation without resetting, press <b>Esc</b> rather than pressing <b>Enter</b>.</p> <p><b>Note:</b> This same reset sequence can be initiated when turning the Spectrum Master On by pressing and holding the <b>Esc+On</b> keys until the Anritsu splash screen is displayed.</p> <p><b>Master Reset:</b> Press this submenu key to restore the factory setting to all system parameters, including Ethernet, language, and brightness settings. Also, all user files in the internal memory are deleted, and the original language and antenna files are restored. Press the <b>Enter</b> key to initiate the reset. The Spectrum Master is automatically rebooted as part of this operation. To return to normal operation without resetting, press <b>Esc</b> rather than pressing <b>Enter</b>.</p> <p><b>Note:</b> This same reset sequence can be initiated when turning the Spectrum Master On by pressing and holding the <b>System</b> (8)+<b>On</b> keys until the Anritsu splash screen is displayed.</p> <p><b>Update Firmware:</b> Press this submenu key to update the instrument operating system using an external USB drive. Press <b>Enter</b> to begin the update, or press <b>Esc</b> to return to normal operation without updating. Refer to <a href="#">“Update Firmware” on page 5-7</a> for additional information.</p> <p><b>Frequency Blanking On/Off (Option 7 Only):</b> The Frequency Blanking submenu only displays when Option 7, Secure Data is installed on the Spectrum Master. When Frequency Blanking is turned On, all frequency values that are displayed on the screen and menu buttons are replaced with <b>##.#####</b>. This security measure allows the use of the instrument without sensitive frequency information being displayed on the screen.</p> <p>Setting Frequency Blanking to Off will preset the instrument settings and frequencies to the factory default settings (the current frequency settings will not be saved or displayed on the instrument).</p> <p><b>Back:</b> Press this submenu key to return to the <a href="#">“System Options Menu” on page 5-3</a>.</p>
Factory Defaults	
Master Reset	
Update Firmware	
Frequency Blanking	
On <u>Off</u>	
Back	
←	

**Figure 5-5.** Reset Menu

## 5-4 Preset Menu

Key Sequence: **Shift, Preset** (1)

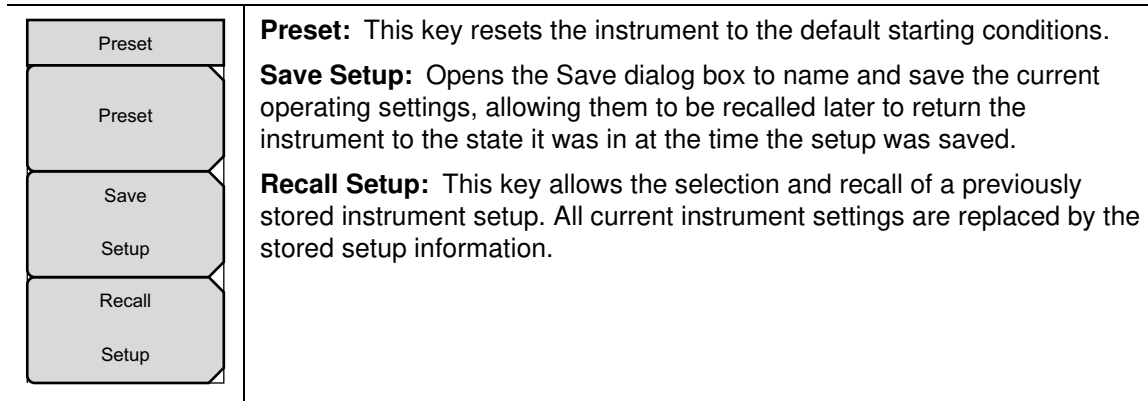

Figure 5-6. Preset Menu

## 5-5 Self Test

At power on, the Spectrum Master runs through a series of quick checks to ensure that the system is functioning properly. The System self test runs a series of tests that are related to the instrument. The Application Self Test runs a series of tests that are related to the current operating mode of the instrument.

If the Spectrum Master is within the specified operating range with a charged battery, and if the self test fails, then contact your Anritsu Service Center.

To initiate a self test when the system is already powered up:

1. Press the **Shift** key and then the **System** (8) key.
2. Press the Self Test submenu key. The Self Test results are displayed.

Press the **Esc** key to continue.

## 5-6 Update Firmware

### Using a USB Memory Device

The Spectrum Master contains a feature that allows you to update its firmware by using a USB memory device. First, you must load the USB memory device with the firmware using Master Software Tools (MST). Review the section (in MST Help) that discusses this process. After the firmware is loaded onto the USB memory device, follow the instructions below to update the firmware on your Spectrum Master.

1. Insert the USB Memory Stick into the USB port.
2. Press the follow key sequence: **Shift > System (8) > System Options > Reset > Update Firmware**. The Load Firmware main menu key is displayed ([Figure 5-7](#)).

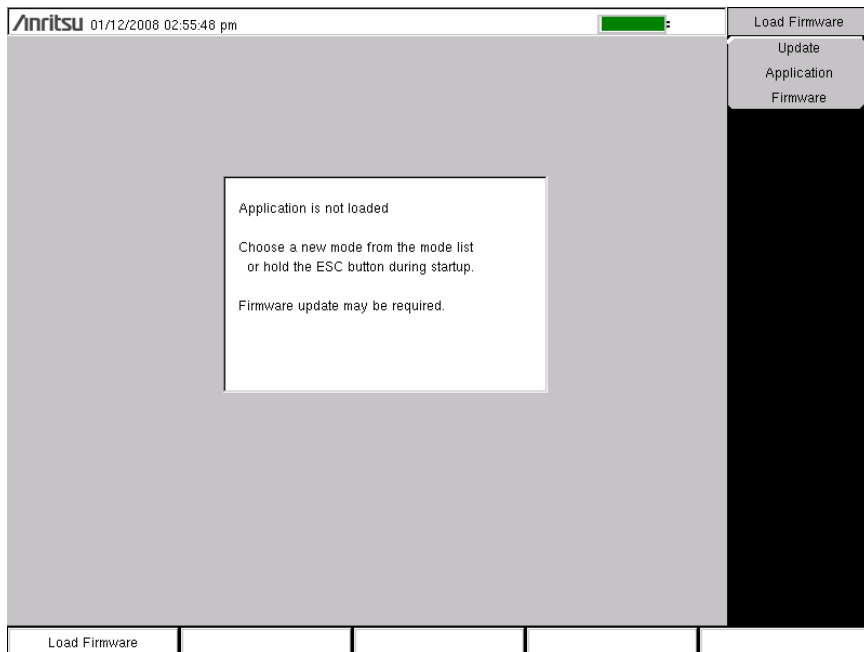

**Figure 5-7.** Firmware Main Menu

3. Press the **Load Firmware** main menu key to list the Firmware Update menu and the Update Application Firmware submenu key.
4. Press the Update Application Firmware submenu key, and the Firmware Update dialog opens ([Figure 5-8](#)).



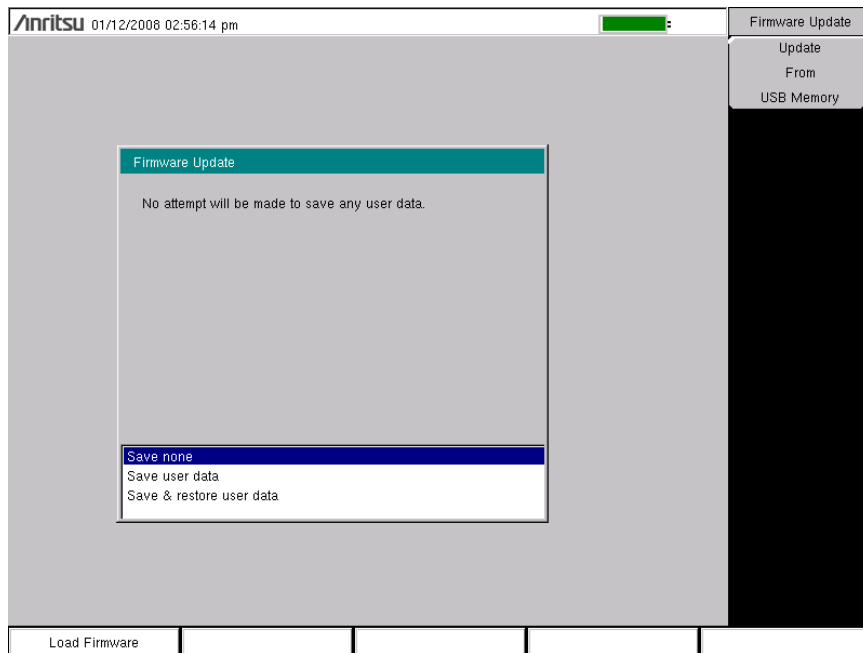

**Figure 5-8.** Firmware Update Menu

5. Highlight each of the save choices: **Save None**, **Save User Data**, and **Save & Restore User Data**. Read through each choice carefully and then select the desired save mode.

- **Save None:** No attempt will be made to save any user data.
- **Save User Data:** User data will be save to the selected external media device.

**Warning** If not enough memory space is available for all user data, then some data may be lost during this process.

- **Save & Restore:** User data will be saved to the selected external media device. The instrument will also attempt to restore the files to the instrument after the update.

**Warning** If not enough memory space is available for all user data, then some data may be lost during this process.

6. Press **Enter** to begin the firmware update process. To abort the process, press **Esc**, then choose another analyzer mode or power down.

7. The Firmware Update dialog will query you to confirm the process by pressing **Enter** to continue or **Esc** to abort (Figure 5-9).

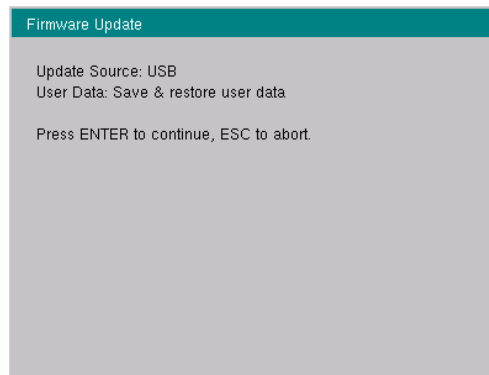

**Figure 5-9.** Firmware Update Menu

8. Select **Enter** and the firmware update process begins. The Firmware Update dialog displays the following message:  
Updating firmware. Please Wait.
9. When complete, the instrument will reboot.

## Update Firmware Using Master Software Tools

Refer to “[Updating Instrument Firmware](#)” on page 7-2 in Chapter 7, “[Master Software Tools](#)”.



# Chapter 6 — GPS (Option 31)

## 6-1 Introduction

The Spectrum Master MS272xC is available with a built-in GPS receiver feature (Option 31) that can provide latitude, longitude, altitude, and UTC timing information. When GPS is actively locked to satellites, this information is saved with all saved measurements and can be displayed with Master Software Tools. This option also enhances frequency reference oscillator accuracy.

## 6-2 Setting Up GPS (Option 31)

In order to acquire data from the GPS satellites, you must have line-of-sight to the satellites, or the antenna must be placed outside without any obstructions. In addition to Option 31, the Spectrum Master requires a GPS antenna, Anritsu part number 2000-1523-R.

### Activating the GPS feature:

1. Attach the GPS antenna to the GPS Antenna connector on the top of the instrument.
2. Press the **Shift** key then the **System** (8) key on the numeric keypad to display the System menu.
3. Press the GPS submenu key to display the GPS menu.
4. Activate GPS by pressing the GPS, On/Off submenu key so that **On** is underlined. When GPS is first turned On, the GPS icon is displayed in red.



**Figure 6-1.** GPS Icon, Red

5. Press the GPS Info submenu key to open the GPS Info window, which displays:
  - Tracked Satellites
  - Latitude
  - Longitude
  - Altitude
  - UTC timing information
  - Fix available
  - Antenna Status
  - Receiver Status
  - GPS Antenna current and voltage

6. When the GPS receiver is tracking at least 3 satellites, the GPS icon changes to green.



**Figure 6-2.** GPS Icon, Green

**Note**

As long as 3 minutes may be required for the Ref Freq status to change to GPS High Accuracy in the Status menu, which is displayed on the left side of the measurement display.

To reset the GPS, press the Reset submenu key. The green GPS icon with a red cross appears when GPS satellite tracking is lost (refer to [Figure 6-3](#)). This occurs after being active (tracking three or more satellites).



**Figure 6-3.** GPS Icon, Green with Red Cross

After GPS location Fix is attained, the internal reference oscillator begins to correct its frequency to match the GPS standard. After the internal frequency is adjusted to match the GPS standard, the status is indicated by “GPS High Accuracy” showing in the Status menu, which is displayed on the left side of the measurement display. When the GPS feature is not enabled, the reference source displays either “Internal Standard Accuracy” or a user-selected external reference frequency in the Status menu.

Within three minutes of satellite acquisition, the reference oscillator will have an accuracy of better than 25 ppb (parts per billion). The OCXO internal standard accuracy is  $\pm 0.3$  PPM. The correction factor applied to the internal OCXO allows the instrument to maintain GPS frequency accuracy for three days at better than 50 ppb, even when the instrument is obstructed from receiving signals from the GPS satellites.

In order to acquire data from the GPS satellites, you must have line-of-sight to the satellites, or the antenna must be placed outside with no obstructions.

Option 31 requires a GPS antenna, Anritsu part number 2000-1523-R.

# Chapter 7 — Master Software Tools

## 7-1 Introduction

This chapter provides a brief overview of Master Software Tools (MST), firmware update, and emergency repair procedures. For detailed information about Master Software Tools, refer to the MST Manual on the CD-ROM that was included with the Spectrum Master. The major sections of this chapter include:

- [“Master Software Tools Overview” on page 7-1](#)
- [“MST Feature Overview” on page 7-1](#)
- [“Updating Instrument Firmware” on page 7-2](#)
- [“Emergency Repair Procedure” on page 7-7](#)

## 7-2 Master Software Tools Overview

Anritsu Master Software Tools is a Microsoft Windows compatible program (for Windows 2000, Windows XP, and 64-bit Windows Vista) for transferring and editing saved measurements, markers, and limit lines to a PC. Master Software Tools will not function on earlier versions of the Microsoft Windows operating system.

## 7-3 MST Feature Overview

### Capturing or Retrieving Traces

MST includes a feature to capture the current screen and associated data from the test instrument to the Master Software Tools Graphic Display Editor window. Saved files on the test instrument can also be retrieved and displayed or edited with Master Software Tools.

### Editing Graphs

MST can be used to change the scale, limit lines, and markers in a measurement through the Edit Graph button in the workspace toolbar, or through the Context Menu.

### Context Menus

Context Menus are accessed by right-clicking the mouse on an active measurement screen in the Graphic Display Editor Window. Context Menu functions may include commands that are also available on the pull down menus and toolbar buttons, or functions, commands, and options specific to the active measurement window.

### Overlaying Traces

Trace Math and Overlays allow for comparing multiple traces.

### Folder Spectrogram

Folder Spectrogram provides a simulated three dimensional view of a large amount of data in one set of graphs.

### 3D Spectrogram View

The 3D Spectrogram function allows you to view a folder of measurement traces in true three dimensions: frequency, time, and amplitude. You can use markers to select or point out specific frequencies and amplitudes. With Signal ID, you can view specific types of signals and their signal-to-noise ratio (SNR). 3D Spectrogram requires Microsoft DirectX running on your PC.

### Script Master

Script Master is an editor that is used to create files that set up measurement parameters and create automated test procedures that aid field technicians or field application engineers with measurement testing.

## 7-4 Installing MST

MST is provided on the CD-ROM that is included with the instrument. Insert the CD-ROM into a PC to run the installer. Follow the onscreen instruction.

## 7-5 Updating Instrument Firmware

1. Connect the Spectrum Master to a PC by using USB or Ethernet. Refer to the Master Software Tools (MST) User Guide (on the CD-ROM) for information regarding connecting your Spectrum Master to a PC.

If you are using USB, then refer to [Section 5-6 “Update Firmware” on page 5-7](#). If you are using Ethernet, then continue with [Step 2](#).

2. Run Master Software Tools
3. From the Connection menu:

- for a USB Connection, Select Connect – USB.
- for an Ethernet Connection:
  - a. Enter the IP Address of your Spectrum Master by first clicking Enter IP Address...
  - b. Then click Connect – Ethernet: xxx.xxx.xxx.xxx
- In either type of connection, the connection type is displayed in the toolbar.



**Figure 7-1.** IP Address in Connection Button

4. From the Tools menu, click Product Updates.

The Product Updates window opens.



**Figure 7-2.** Tool Menu: Product Updates Command

5. Notice the differences in the two Product Updates windows in [Figure 7-3](#) and [Figure 7-4](#).

- File Status Ready

In [Figure 7-3](#), the status of the highlighted file is Ready, and the Install to Unit button is active. You can immediately click Install to Unit to update your Spectrum Master with the new firmware.

- File Status Available

In [Figure 7-4](#), the status of the highlighted file is Available, and the Install to Unit button is gray and inactive. This means that the updated file is on the Anritsu Product Support Web site and needs to be downloaded to your PC. After the file has been downloaded and placed on your PC, its status changes to Ready, and the Install to Unit button becomes active.



**Note**

Screen captured images are provided as examples. The images shown on your instrument may differ from the examples in this user guide.

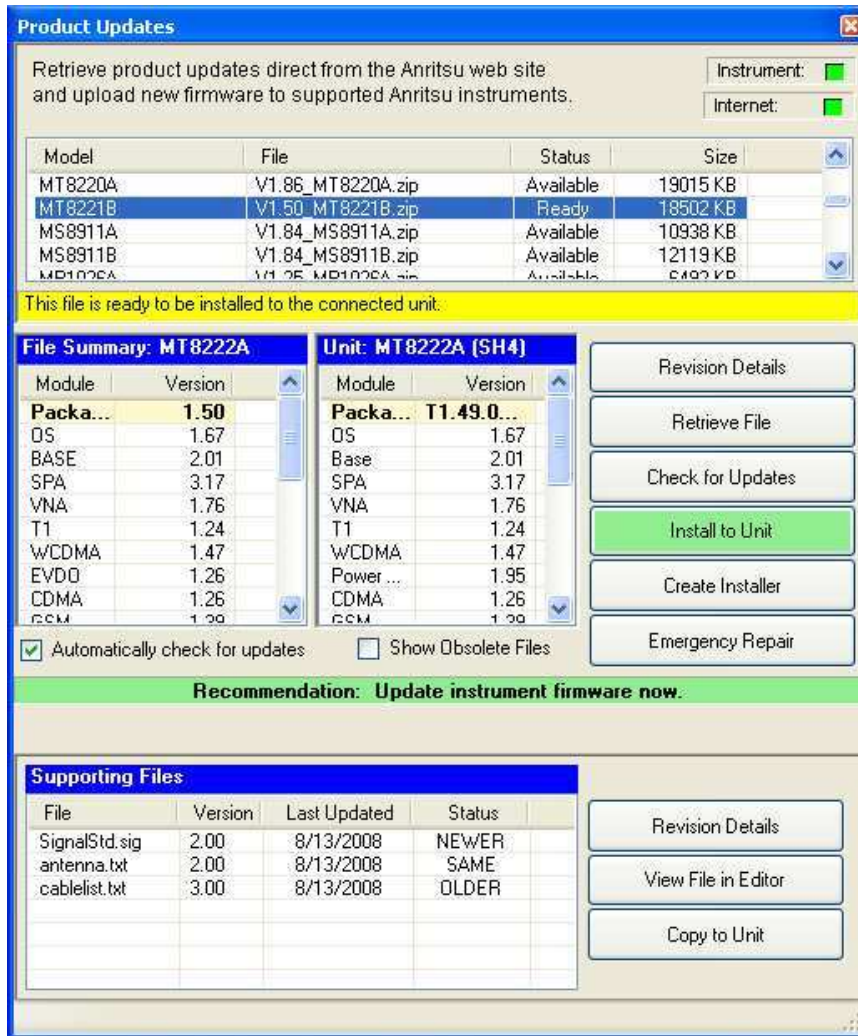
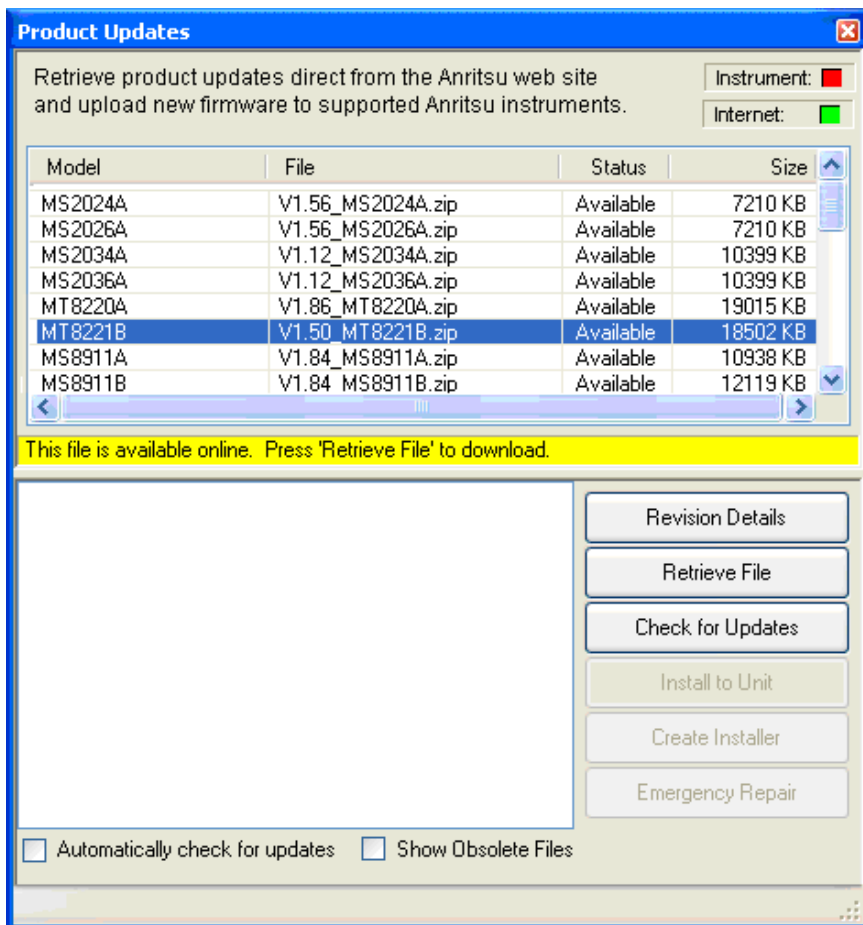

Figure 7-3. Product Updates Window: Status Ready



**Figure 7-4.** Product Updates Window: Status Available

**File Status Ready:**

1. Check that the file status is Ready and that the Install to Unit button is active.
2. Click the Install to Unit button. Your Spectrum Master is updated with the new firmware.

**File Status Available:**

1. Check that the file status is Available.
2. Click Retrieve File to download the file from the Web site to your PC.
3. Check that the file status changes to Ready.
4. Click the Install to Unit button. Your Spectrum Master is updated with the new firmware.

**File Not Listed:**

You might open the Product Updates window and not find the file that you are looking for. In that case:

1. Click the **Check for Updates** button. Master Software Tools checks for the latest updates at the Anritsu Product Support Web Site. New updates that are found are listed in the file menu.
2. Click the **Retrieve File** button. The file is transferred from the Web site to your PC.
3. After the status changes to **Ready**, click the now-active **Install to Unit** button. Your Spectrum Master is updated with the new firmware.

**Update Problems**

If you do not find the latest update, or if you encounter a problem with updating the firmware, then contact Anritsu. Internet links to worldwide Anritsu locations can be found at the following URL:

<http://www.anritsu.com/Contact.asp>

**Update Firmware by Using a USB Device**

Refer to the Master Software Tools (MST) User Guide (on the CD-ROM) for information regarding connecting your Spectrum Master to a PC. Also refer to [Section 5-6 “Update Firmware”](#) on page 5-7.

## 7-6 Emergency Repair Procedure

If you have problems booting up your Spectrum Master after updating the firmware on your Spectrum Master, then use the following steps to resolve the problem. Refer to [Figure 7-5](#).

1. Close the Master Software Tools application and then restart it.
2. Turn off the Spectrum Master. Connect the Spectrum Master via Ethernet to your local network or directly to your PC using the Ethernet cross-over cable.
3. Turn on the Spectrum Master in bootstrap mode as follows:
  - a. With the Spectrum Master off, hold the first, third, and fifth submenu keys (located at the right edge of the measurement display screen).
  - b. While holding all 3 submenu keys, press the **On/Off** button.
  - c. Continue holding all 3 submenu keys until the Anritsu logo appears on the measurement display screen, then release them.



**Figure 7-5.** Spectrum Master Bootstrap Screen

4. Press the Ethernet Configuration submenu key (the first submenu key, as shown in [Figure 7-5](#)).

5. Wait until the Ethernet menu is displayed, as shown in [Figure 7-6](#).

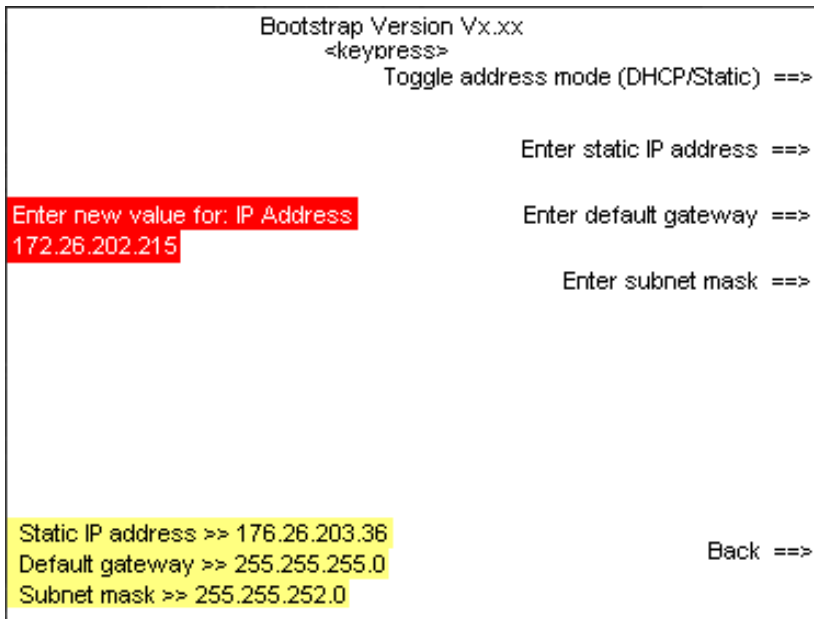

**Figure 7-6.** Ethernet Menu

Additional explanations of the Ethernet menu submenu keys can be found in [Appendix C “Ethernet Menu” on page C-4](#).

- If your Spectrum Master is configured for DHCP, then it immediately attempts to obtain (lease) an IP address from the network DHCP server, and then displays the IP address at the lower-left corner of the measurement display screen. If an IP address is successfully acquired, then note and write down the IP address. Press the **Back** key, skip [Step 6](#) and [Step 7](#), and go next to [Step 8](#).
- If the Spectrum Master cannot obtain an IP address from the DHCP server, then it will time out after approximately 3 minutes. The statement “DHCP Lease Failed” will be displayed at the lower-left corner of the measurement display screen. Go to [Step 6](#), “[DHCP Mode Second Attempt](#)”.
- If your Spectrum Master is configured for STATIC IP, then it opens to the Static IP configuration window and displays the current Static IP address at the lower-left corner of the measurement display screen. To reconfigure the Static IP address, go to [Step 7](#), “[Static Address Mode](#)”.

#### 6. DHCP Mode Second Attempt

- a. Confirm that the connections, the Ethernet line, and communication on the LAN to the test instrument are all functioning correctly.
- b. Reattempt to obtain an IP address through DHCP configuration. Press the first submenu key, Press the **Type** submenu key to toggle the address mode (Manual or DHCP) to switch to DHCP configuration and automatically obtain an IP address. Note and write down the IP address that is assigned to the Spectrum Master.
- c. Press the **Back** submenu key. Return to the main bootstrap screen and go to [Step 8](#).

**7. Static Address Mode**

- a. Press the second submenu key. Enter the IP address.
  - b. Press the third submenu key. Enter the gateway address.
  - c. Press the fourth submenu key. Enter the subnet mask.
  - d. Attach the Ethernet network cable between the test instrument and your PC.
  - e. Press the Back submenu key, to return to the main bootstrap screen.
8. Press the Update OS (Ethernet) submenu key (the second submenu key in the bootstrap menu, as shown in [Figure 7-5](#)).

The Spectrum Master should give you a “Waiting for OS download connection” message.

9. In Master Software Tools, go to the Tools menu and click Product Updates.



**Figure 7-7.** Tool Menu: Product Updates Command

10. The Product Updates window opens. At this point, Master Software Tools is not yet connected to your Spectrum Master.

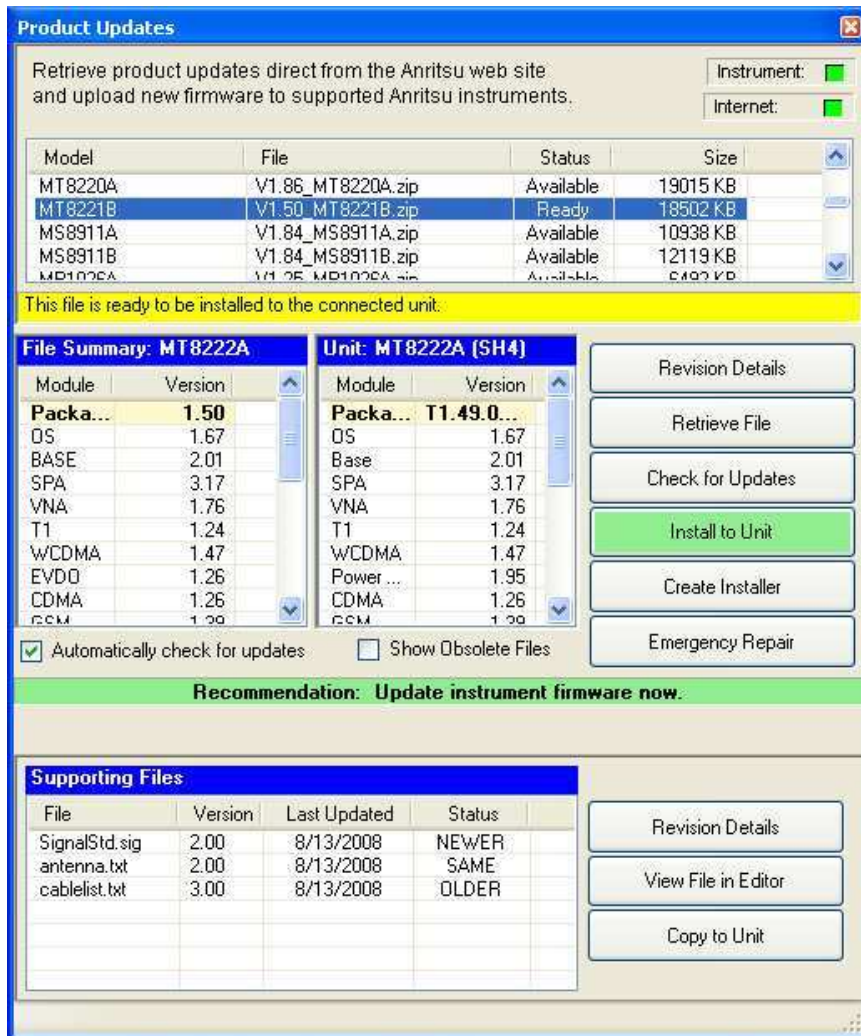

Figure 7-8. Product Updates Window: Status Ready

11. Highlight the firmware that you wish to load into your Spectrum Master. If its status is “Ready”, then the file is located on the PC, and the Emergency Repair button is active. If the file status is listed as “Available”, then click on the Retrieve File button to download the file from the Anritsu web site to your PC. After the file has been downloaded, its status changes to Ready. Highlight that file.

**For Files Not Listed**

If the file that you are looking for is not on the list, then:

Click the “Check for Updates” button to obtain the latest list from the Anritsu Web site. This updates the Product Updates screen.

**Note**

If a zip (compressed) file was sent to you from Anritsu Company, then:

Copy the zip file to the MST folder. The default location is  
C:\Program Files\Anritsu\Anritsu Master Software Tools\Archives

Select the box next to “Show Obsolete Files” at the bottom of the Product Updates screen. This updates the list.

12. Click the Emergency Repair button in the Product Updates window. The OS Recovery window opens.

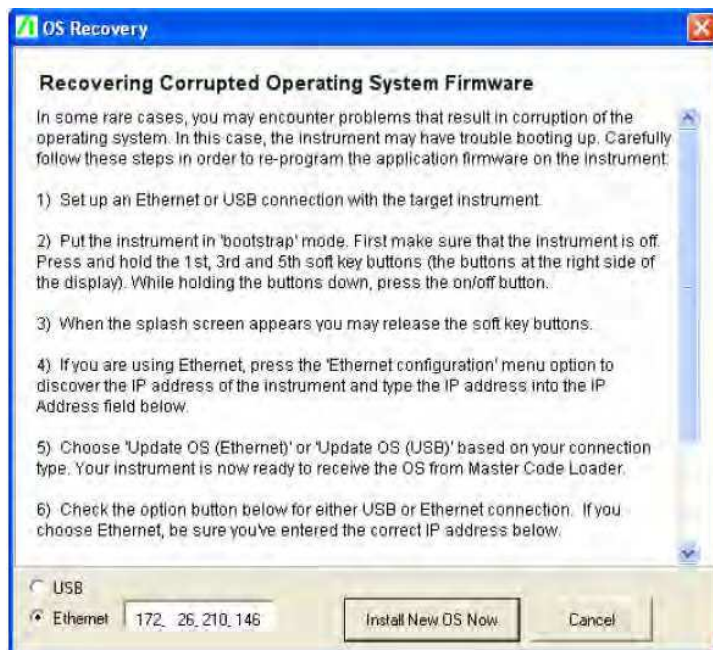

**Figure 7-9.** OS Recovery Window

13. In the OS Recovery window, click the Ethernet option button (at the bottom of the window, under the USB option button).
  - a. Enter the IP address of your Spectrum Master.
  - b. Click the “Install New OS Now” button. Master Software Tools connects to your Spectrum Master and begins to install the firmware. Progress messages appear above the buttons. Be patient, the installation can take several minutes.
14. When your Spectrum Master is done loading the new OS firmware, it should automatically reboot. If it does not reboot, then turn off the Spectrum Master, and then turn it on. The Spectrum Master should start up normally.





# Appendix A — Measurement Guides

## A-1 Introduction

This appendix provides a list of supplemental documentation for Spectrum Master features and options. The measurement guides are available as PDF files on the Documentation disc or the Anritsu web site. The Technical Data Sheets are available on the Anritsu web site.

**Table A-1.** Analyzers and Analyzer Options (1 of 2)

<b>Spectrum Master Feature (Required Option)</b>	<b>Related Document (Part Number)</b>
Spectrum Analyzer Interference Analyzer (0025) Channel Scanner (0027) Zero-Span IF Output (0089)	Spectrum Analyzer Measurement Guide (10580-00244)
High-Accuracy Power Meter (0019)	Power Meter Measurement Guide (10580-00240)
GSM/GPRS/EDGE RF Signal Analyzer (0040) GSM/GPRS/EDGE Demodulated Signal Analyzer (0041) W-CDMA/HSDPA RF Signal Analyzer (0044) W-CDMA Demodulated Signal Analyzer (0045) W-CDMA/HSDPA Demodulated Signal Analyzer (0065) W-CDMA/HSDPA Over-the-Air Signal Analyzer (0035) TD-SCDMA/HSDPA RF Signal Analyzer (0060) TD-SCDMA/HSDPA Demodulated Signal Analyzer (0061) TD-SCDMA/HSDPA Over-the-Air Signal Analyzer (0038) LTE RF Measurements (0541) LTE Modulation Measurement (0542) LTE Over-the-Air Measurements (0546)	3GPP Signal Analyzer Measurement Guide (10580-00234)
cdmaOne/CDMA2000 1X RF Signal Analyzer (0042) cdmaOne/CDMA2000 1X Demodulated Signal Analyzer (0043) cdmaOne/CDMA2000 1X Over-the-Air Signal Analyzer (0033) CDMA2000 1xEV-DO RF Signal Analyzer (0062) CDMA2000 1xEV-DO Demodulated Signal Analyzer (0063) CDMA2000 1xEV-DO Over-the-Air Signal Analyzer (0034)	3GPP2 Signal Analyzer Measurement Guide (10580-00235)

**Table A-1.** Analyzers and Analyzer Options (2 of 2)

<b>Spectrum Master Feature (Required Option)</b>	<b>Related Document (Part Number)</b>
IEEE 802.16 Fixed WiMAX RF Signal Analyzer (0046) IEEE 802.16 Fixed WiMAX Demodulated Signal Analyzer (0047) IEEE 802.16 Mobile WiMAX RF Signal Analyzer (0066) IEEE 802.16 Mobile WiMAX Demodulated Signal Analyzer (0067) IEEE 802.16 Mobile WiMAX Over-the-Air Signal Analyzer (0037)	WiMAX Signal Analyzer Measurement Guide (10580-00236)
Performance Specifications  MS2722C MS2723C MS2724C MS2725C MS2726C	Spectrum Master Technical Data Sheets  11410-00529 11410-00524 11410-00525 11410-00525 11410-00526
Programming Manual	Spectrum Master Programming Manual (10580-00278)
Maintenance Manual	Spectrum Master Maintenance Manual (10580-00279)
Computer Software Application	Master Software Tools (CD-ROM or Download)

# Appendix B — Error Messages

## B-1 Introduction

This chapter provides a list of information and error messages that could be displayed on the MS272xC Spectrum Master. If any error condition persists, then contact your local [Anritsu Service Center](http://www.anritsu.com/Contact.asp) (<http://www.anritsu.com/Contact.asp>).

## B-2 Self Test or Application Self Test Error Messages

### Overall Status FAILED

One or more elements of the System or Application Self Test has failed. Refer to the other pass fail tests listed below to determine which specific test failed.

### ADC Self Test FAILED

The Analog to Digital converter failed to return an answer. Insure that the battery level is adequate for operation or that the temperature is within acceptable limits. Reset to factory defaults with either Factory Defaults, ESC+ON, or MASTER RESET, System+ON.

**Caution:** Use of MASTER RESET, System+ON, will erase all user saved setups and measurement traces and return the unit to a fully Factory Default condition. If the error persists, then contact your Anritsu Service Center.

### DDC FAILED

The Digital Down Converter failed to return a value. Insure that the battery level is adequate for operation or that temperature is within acceptable limits. Reset to factory defaults with either Factory Defaults, ESC+ON, or MASTER RESET, System+ON. **Caution:** Use of MASTER RESET, System+ON, will erase all user saved setups and measurement traces and return the unit to a fully Factory Default condition. If the error persists, then contact your Anritsu Service Center.

### Lock Test FAILED

One or more Phase Lock Loops Failed to properly achieve Lock Status. Insure that the battery level is adequate for operation or that temperature is within acceptable limits. Reset to factory defaults with either Factory Defaults, ESC+ON, or MASTER RESET, System+ON.

**Caution:** Use of MASTER RESET, System+ON, will erase all user saved setups and measurement traces and return the unit to a fully Factory Default condition. If the error persists, then contact your Anritsu Service Center.

### Over Power FAILED

RF Power applied to the input connector is too high. Remove or reduce the input power or add additional attenuation. Sometimes out of band frequencies may be present that can cause an Over Power Error. In highly rich RF environments it may be necessary to add an external band pass filter to reduce unwanted interference. See the accessories section for a list of available band pass filters from Anritsu. Out of band frequencies can often be detected by increasing the Span to maximum in the peak detect mode of operation. Another resolution may be to reset to factory defaults with either Factory Defaults, ESC+ON, or MASTER RESET, System+ON. **Caution:** Use of MASTER RESET, System+ON, will erase all user saved setups and measurement traces and return the unit to a fully Factory Default condition. If the error persists, then contact your Anritsu Service Center.

### Over Power Start FAILED

RF Power applied to the input connector is too high at turn on. See Over Power FAILED error above.

Mixer Saturation: Increase Attenuation

or

### Mixer Overdrive FAILED

Too much power applied with too little Attenuation. Increase attenuation. Sometimes even out of band frequencies may be present that would cause a Mixer Overdrive Error. In highly rich RF environments it may be necessary to add an external band pass filter to reduce unwanted interference. See the accessories section for a list available band pass filters from Anritsu. Out of band frequencies can often be detected by increasing the SPAN to maximum in peak detect mode of operation. Another resolution may be to Reset to factory defaults with either Factory Defaults, ESC+ON, or MASTER RESET, System+ON. **Caution:** Use of MASTER RESET, System+ON, will erase all user saved setups and measurement traces and return the unit to a fully Factory Default condition. If the error persists, then contact your Anritsu Service Center.

## B-3 Operation Error Messages

ADC Over range: Increase Reference Level

Input signal is too large for the Analog to Digital converter to process. Increase the internal or external attenuation or, if using Auto attenuation, then increasing the Reference Level should resolve the error. See also the “[Mixer Overdrive FAILED](#)” error (described previously) for information on Out of Band RF power.

Calibrator Reading Error

Calibration reference source is not providing quality signal. Insure that the battery level is adequate for operation or that temperature is within acceptable limits. Reset to factory defaults with either Factory Defaults, ESC+ON, or MASTER RESET, System+ON.

**Caution:** Use of MASTER RESET, System+ON, will erase all user saved setups and measurement traces and return the unit to a fully Factory Default condition. If the error persists, then contact your Anritsu Service Center.

Fatal Error

Usually caused by a failure to communicate with one section or another. Sometimes resolved by restarting the unit or by Factory Defaults, ESC+ON, resetting of the unit. Under extreme cases the use of MASTER RESET, System+ON, may resolve the issue. **Caution:** Use of MASTER RESET, System+ON, will erase all user saved setups and measurement traces and return the unit to a fully Factory Default condition. If the error persists, then contact your Anritsu Service Center.

Trace not saved. Please wait for complete sweep and try again.

Attempted to save a measurement trace before the sweep had completed at least once. Wait for at least one complete sweep and try to save again.

Measurement not valid in Zero Span

Attempt was made to make an automated measurement that requires more than ZERO SPAN to accomplish. An example would be Occupied Bandwidth measurement.

The Freq range of the Antenna is invalid for this setup. Please select another Antenna

Choose a start and stop frequency that is within the defined frequency range for the selected antenna compensation table. See also Master Software Tools for creation and Upload of Antenna correction files.

Minimum permitted Sweep time is 50  $\mu$ s

An attempt was made to set the minimum Sweep time to less than 50  $\mu$ s.

Invalid Attenuation for Preamp

The only valid attenuation settings while the Preamp is operational are 0 dB, 5 dB and 10 dB. All other settings attempted by the user will result in this message. Select 0 dB, 5 dB or 10 dB or select AUTO Attenuation to let the system determine the correct setting based on the reference level selected.

Valid Attenuations with Preamp on are 0 dB, 5 dB and 10 dB

Same as above

Unable to add additional limit points. %d is the maximum.

Attempted to add an additional limit line point beyond the maximum number of allowed points.

Use Demod type USB or LSB to use Beat Frequency Osc

An attempt to use the Beat Frequency Oscillator while not in Upper or Lower Sideband Demodulation mode.

Trace A/B/C has no data to view

Attempt to turn on or VIEW a trace that has never had data recalled into this trace location. Refer to Recall Trace section for instructions on how to recall stored measurement traces into either Trace A, B or C.

Locking to Internal Ref failed

Switching from an external frequency reference to the internal reference has failed. Some additional warm up time may be needed if the unit has been on external reference for a long time or if the unit is not warmed up enough.

Locking to External Ref failed; Lock attempt Failed

Switching from an internal frequency reference to the external reference has failed. Verify that the correct external reference frequency value has been selected from the list of valid external reference frequencies. Verify that the level of the external reference frequency is at least 1vp-p.

Fatal error, EEPROM failed

Hardware communications between modules has failed. Insure that the battery level is adequate for operation or that temperature is within acceptable limits. Reset to factory defaults with either Factory Defaults, ESC+ON, or MASTER RESET, System+ON.

**Caution:** Use of MASTER RESET, System+ON, will erase all user saved setups and measurement traces and return the unit to a fully Factory Default condition. If the error persists, then contact your Anritsu Service Center.

**Fatal error, no SPA board connected**

Hardware communications between modules has failed. Insure that the battery level is adequate for operation or that temperature is within acceptable limits. Reset to factory defaults with either Factory Defaults, ESC+ON, or MASTER RESET, System+ON.

**Caution:** Use of MASTER RESET, System+ON, will erase all user saved setups and measurement traces and return the unit to a fully Factory Default condition. If the error persists, then contact your Anritsu Service Center.

**Operation not Permitted in Recall Mode**

Attempted to perform an operation on a recalled trace. Many operations are valid only on a live or active trace.

**Cannot change scale in Linear mode**

Linear display mode of operation does not support a scaling change in the same manner as the Log display mode.

**Cannot turn on delta marker because Ref Marker is invalid**

Delta markers cannot be enabled unless the primary marker is within the displayed span.

**Cannot turn on delta marker because Ref Marker is a counter Marker**

Delta markers cannot be enabled unless the primary marker is NOT a counter Marker. Turn off the Counter Marker mode of marker operation to use Delta Marker.

**Current Marker is not ON**

Attempted to use a marker mode or feature for a marker that is not enabled. Turn on the appropriate marker to use this function or switch to a marker that is already enabled.

**Marker must be ON to Use the feature**

Attempted to use a marker mode or feature for a marker that is not enabled. Turn on the appropriate marker to use this function or switch to a marker that is already enabled.

**Triggering valid only in Zero Span**

External triggering can only be used while the SPAN is set to 0 (zero)

**Cannot change Modes for Recalled/Inactive Traces**

Detection modes or other elements such as RBW/VBW, averaging, and so forth, cannot be altered on a recalled trace. The trace is displayed with the same parameters in which it was saved.

**Cannot change average for Recalled/Inactive Traces**

Cannot set Delta Detection modes or other elements such as RBW/VBW, averaging, and so forth, cannot be altered on a recalled trace. The trace is displayed with the same parameters in which it was saved.

**Pretune Calibration Table fault**

Ensure that the battery level is adequate for operation or that temperature is within acceptable limits. Reset to factory defaults with either Factory Defaults, ESC+ON, or MASTER RESET, System+ON. **Caution:** Use of MASTER RESET, System+ON, will erase all user saved setups and measurement traces and return the unit to a fully Factory Default condition. If the error persists, then contact your Anritsu Service Center.

### Lock failed during initialization

One or more of the Phase Lock Loops failed to achieve lock status during startup. Insure that the battery level is adequate for operation or that temperature is within acceptable limits. Reset to factory defaults with either Factory Defaults, ESC+ON, or MASTER RESET, System+ON. **Caution:** Use of MASTER RESET, System+ON, will erase all user saved setups and measurement traces and return the unit to a fully Factory Default condition. If the error persists, then contact your Anritsu Service Center.

### Reference LVL Cal is OFF

Factory Calibration is OFF. Insure that the battery level is adequate for operation or that the temperature is within acceptable limits. Reset to factory defaults with either Factory Defaults, ESC+ON, or MASTER RESET, System+ON. **Caution:** Use of MASTER RESET, System+ON, will erase all user saved setups and measurement traces and return the unit to a fully Factory Default condition. If the error persists, then contact your Anritsu Service Center.

### IF Cal is OFF

Factory Calibration is OFF. Insure that the battery level is adequate for operation or that the temperature is within acceptable limits. Reset to factory defaults with either Factory Defaults, ESC+ON, or MASTER RESET, System+ON. **Caution:** Use of MASTER RESET, System+ON, will erase all user saved setups and measurement traces and return the unit to a fully Factory Default condition. If the error persists, then contact your Anritsu Service Center.

### Cannot set Delta Mkr Freq to Demod Freq

Marker to Demod frequency is only available with a primary marker as the selected marker.

### Fan Failure

The system has determined that the fan should be running due to the internal temperature of the unit, but cannot detect that the fan is actually running.



It is important to keep the fan inlet and exhaust ports clear of obstructions. The cooling fan will vary the speed in relation to the internal temperature of the instrument. The fan will turn on at low speed when the internal temperature of the instrument reaches 44°C, and will increase the fan speed to maximum at 54°C. As the internal temperature of the instrument decreases, the fan will reduce speed until the temperature reaches 39°C, at which point the fan will turn off.

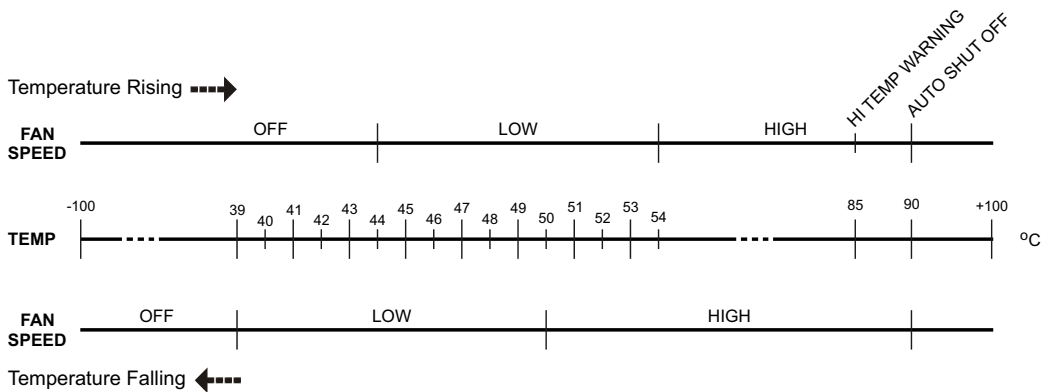

**Figure B-1.** Fan Speed versus Temperature

### High Temp Warning

The internal temperature has reached an excessive level, 85°C. Verify that the ventilation openings are unobstructed and that the fan is running. Internal temperatures may be manually verified by using the SELF TEST function. Turn off the unit and allow the temperature to cool down. If the fault is not resolved and if the internal temperature reaches 90°C, then a countdown of 10 seconds will begin to give the user a chance to save the current setup before it will turn itself off (before internal temperatures can cause any damage). If the error persists after removing any obstructions and allowing the unit to cool, then reset to the factory defaults with either Factory Defaults, ESC+ON. **Caution:** Use of MASTER RESET, System+ON, will erase all user saved setups and measurement traces and return the unit to a fully Factory Default condition. If the error persists, then contact your Anritsu Service Center.

### Copy failed. Please check External USB Memory

Attempt to copy user saved data to the external USB Flash drive has failed. Do not attempt to remove or power down the unit before the copy has completed. Be sure that the USB memory device is not already full and that it is fully inserted into the USB connector .

### PLL Lock Fail

Phase Lock Loop failed to lock.

Trace not saved. Please wait for complete sweep and try again.

Attempted to save a measurement trace before the sweep had completed at least once. Wait for at least one complete sweep and try to save again.

# Appendix C — LAN and DHCP

## C-1 Introduction

This appendix describes network connections for the MS272xC Spectrum Master.

## C-2 Ethernet Configuration

### LAN Connection

The RJ-45 connector is used to connect the Spectrum Master to a local area network. Integrated into this connector are two LEDs. The amber LED shows the presence of a 10 Mbit/s LAN connection when on, and a 100 Mbit/s LAN connection when off. The green LED flashes to show that LAN traffic is present. The instrument IP address is set by pressing the **Shift** key, then the **System** (8) key followed by the System Options submenu key and the Ethernet Config submenu key. The instrument Ethernet address can be set automatically using DHCP, or manually by entering the desired IP address, gateway address, and subnet mask.

**Note**

An active Ethernet cable must be connected to the instrument before it is turned ON in order to enable the Ethernet port for DHCP or for a static IP address.

Depending upon local conditions, the port may remain enabled when changing from DHCP to static IP address, when changing from static IP address to DHCP, or when temporarily disconnecting the Ethernet cable.

If the port becomes disabled, then ensure that an active Ethernet cable is attached to the instrument before cycling the power OFF and back ON.

Dynamic Host Configuration Protocol (DHCP) is an Internet protocol that automates the process of setting IP addresses for devices that use TCP/IP, and is the most common method of configuring a device for network use. To determine if a network is set up for DHCP, connect the MS272xC to the network and select DHCP protocol in the Ethernet Config menu.

Turn the Spectrum Master off, and then on. If the network is set up for DHCP, then the assigned IP address should be displayed briefly after the power up sequence.

To display the IP address with the instrument on, press the **Shift** key, then the **System** (8) key, then the System Options submenu key and the Ethernet Config submenu key. The IP address will be displayed as shown in [Figure C-1](#). The image on the display panel of your Spectrum Master may differ from the image shown here.

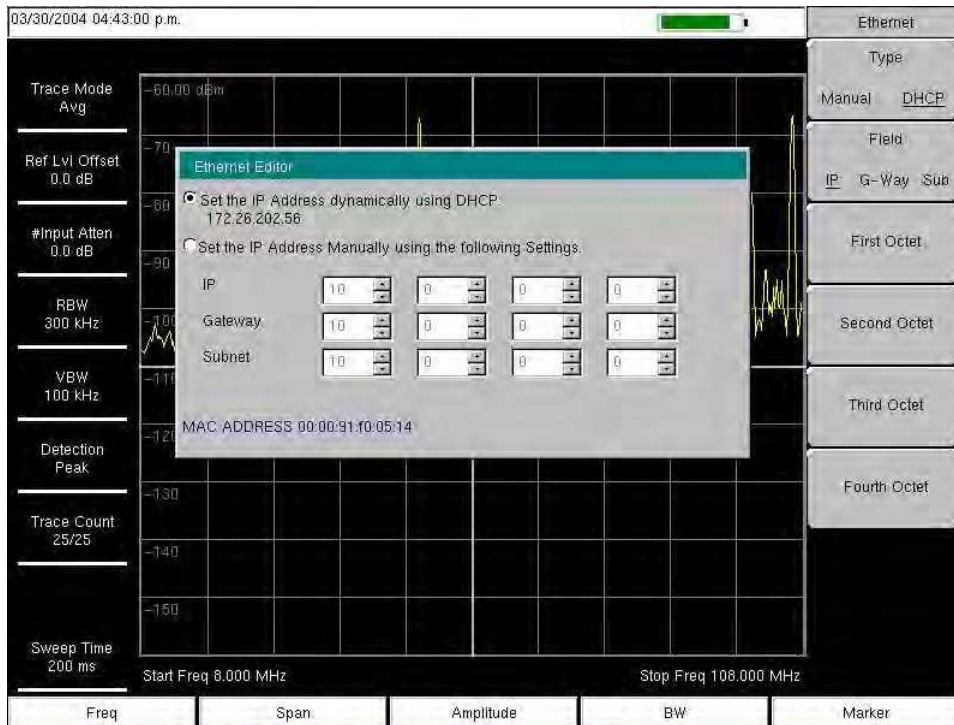

**Figure C-1.** IP Address Assigned Using DHCP

### Ethernet Config

Press this submenu key to display the Ethernet submenu and to open the Ethernet Editor dialog box in order to set the IP address of the instrument.

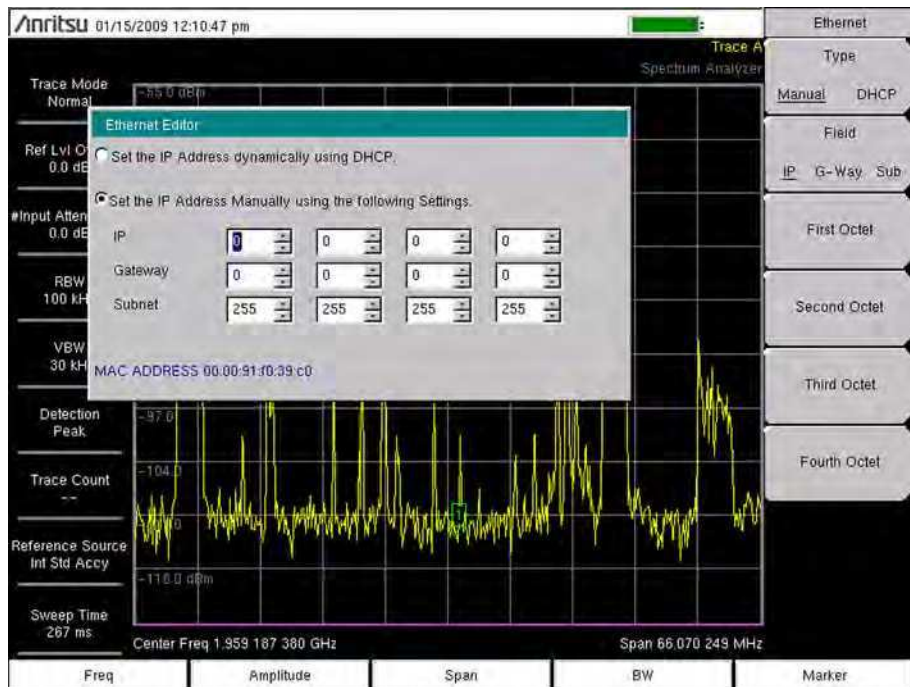

Figure C-2. Setting IP Address Manually

## Ethernet Menu

Key Sequence: **Shift, System (8)** > System Options > Ethernet Config

Ethernet	<b>Type</b> <b>Manual DHCP:</b> Press this submenu key to select whether the address will be entered manually, or will be supplied automatically by a network DHCP server. If Manual is selected, then use the submenu keys or the <b>Left/Right</b> arrow keys to select the field that is to be modified. Use the keypad, the <b>Up/Down</b> arrow keys, or the rotary knob to enter the input. Press <b>Enter</b> to accept the changes, or press the <b>Esc</b> key to return to normal operation without changing anything.
Type Manual DHCP	
Field IP G-Way Sub	<b>Field</b> <b>IP G-Way Sub:</b> Press this submenu key to select the desired Internet Protocol Property to be edited.
First Octet	<b>First Octet:</b> Moves the cursor to the left most column of the selected IP properties field.
Second Octet	<b>Second Octet:</b> Moves the cursor to the second column from the left of the selected IP properties field.
Third Octet	<b>Third Octet:</b> Moves the cursor to the third column from the left of the selected IP properties field.
Fouth Octet	<b>Fourth Octet:</b> Moves the cursor to the forth column from the left of the selected IP properties field.

**Figure C-3.** Ethernet Menu

## C-3 DHCP

DHCP stands for Dynamic Host Configuration Protocol. It is a protocol that allows a server to dynamically assign IP addresses to devices that are connected to the network. Most networks include a DHCP server to manage IP addresses. When a DHCP server is available on the network, DHCP is the preferred IP address assignment mode.

When using DHCP, no setup is required to lease and use a dynamic IP address. In a dynamic IP operation, the IP address in use may change from use to use. The DHCP server hands out IP addresses on a first come, first served basis. As soon as the device is disconnected from the network, the IP address that it was using becomes available to lease to the next unit that requests an IP address. Normally, some amount of lag time is present on the DHCP server end, so if the device is connected again reasonably soon, then it may end up with the same address.

When a DHCP server is not available, a Static IP address can be used. A Static IP address is a fixed address. After being set, it will always remain the same, and care must be taken to not conflict with other equipment on the network.

When using a static IP address on an established network, always request the Static IP address from the network administrator. Randomly choosing a Static IP address on an established network may result in duplicate IP addresses or other conflicts.

Three parameters must be set prior to using a Static IP address:

### **IP Address**

This is the Static IP address on the network.

### **Default Gateway**

Often when a static IP address is assigned, a default gateway is also identified. If the default gateway is unknown, then type in the Static IP address so that the Static IP address and Default Gateway are the same number.

### **Subnet Mask**

This parameter is usually extracted from the Static IP address based on the class of the address and determines the destination of any broadcast messages that might be sent from the instrument. It can be customized if necessary. The subnet mask may also be provided with the Static IP address.

## **Example 1**

In this example, a Static IP address has been chosen because no network DHCP service is available. The instrument is connected to the network port on the PC with a crossover Ethernet cable (not included). This is also referred to as Direct Connect:

```
IP Address: 10.0.0.2
Default Gateway: 10.0.0.2
Subnet Mask: 255.255.0.0
```

## Example 2

In this example, the Static IP address has been assigned with an associated gateway and subnet mask:

```
IP Address: 153.56.100.42
Default Gateway: 153.56.100.1
Subnet Mask: 255.255.252.0
```

## C-4 ipconfig Tool

A few tools that are built into the Microsoft Windows operating system can assist in making some determinations about the network to which the PC is connected. Typing ipconfig at a command prompt produces a display of information about the in-use parameters of the PC and its network connection. Following is an example of the typical results expected:

<b>Note</b>	The ipconfig display does not report whether the information is from a DHCP server or from a Static IP setup.
-------------	---

```
Y:\>ipconfig
Windows 2000 IP Configuration
Ethernet adapter Local Area Connection:
Connection-specific DNS Suffix. : us.anritsu.com
IP Address. . . . . : 172.26.202.172
Subnet Mask . . . . . : 255.255.252.0
Default Gateway . . . . . : 172.26.200.1
```

## C-5 Ping Tool

Another tool that can find out if a selected IP address is already on the network is ping. Ping is a harmless way to determine if an address is found on the network, and (if it is found) to receive a reply. Basically, the ping function sends out a request to a specific address to determine if a computing device is connected to the network at that address. If a valid connection is found, then a copy of the signal (that was sent) is returned. If a connection is not found, then the response is “request timed out”, which means that no reply was received from that IP address.

```
Y:\>ping 172.26.202.172
Pinging 172.26.202.172 with 32 bytes of data:
Reply from 172.26.202.172: bytes=32 time<10ms TTL=128
Reply from 172.26.202.172: bytes=32 time<10ms TTL=128
Reply from 172.26.202.172: bytes=32 time<10ms TTL=128
Reply from 172.26.202.172: bytes=32 time<10ms TTL=128
Ping statistics for 172.26.202.172:
    Packets: Sent = 4, Received = 4, Lost = 0 (0% loss),
    Approximate round trip times in milliseconds:
    Minimum = 0 ms, Maximum = 0 ms, Average = 0 ms
```





# Index

## Numerics

3D spectrogram, MST . . . . . 7-2

### A

adapter, AC-DC . . . . . 1-7, 2-2  
 additional documents . . . . . A-1  
 address, Ethernet IP address . . . . . C-1  
 amplitude, setting . . . . . 3-4  
 Anritsu service centers . . . . . 1-6  
 antenna  
   error, invalid freq range . . . . . B-3  
   ESD cautions . . . . . 1-5  
   GPS  
   antenna location . . . . . 6-2  
   connector, type SMA . . . . . 2-13  
   setting up GPS . . . . . 6-1  
 application self test . . . . . 5-6

### B

bail, tilt bail . . . . . 1-9  
 bandwidth, setting . . . . . 3-3  
 battery  
   charge indicator . . . . . 2-8  
   door (image) . . . . . 1-7  
   instrument long-term storage . . . . . 1-7  
   replacement . . . . . 1-7  
   symbol . . . . . 2-14  
 black and white . . . . . 5-4  
 bootstrap mode . . . . . 7-7  
 brightness . . . . . 5-4

### C

calibration  
   reading error . . . . . B-2  
   Spectrum Master requirements . . . . . 1-5  
   status . . . . . 2-14  
   table fault . . . . . B-4  
 cautions  
   12VDC adapter . . . . . 1-7, 2-2  
   approved batteries and chargers . . . . . 2-14  
   cleaning solvents . . . . . 1-5  
   ESD . . . . . 1-5  
 center frequency settings . . . . . 3-3  
 center frequency, share . . . . . 5-3  
 change directory . . . . . 4-8

cleaning RF connectors . . . . . 1-5  
 connectors, test panel, illustration . . . . . 2-12  
 copy menu . . . . . 4-12  
 create folder . . . . . 4-9

### D

default  
   factory . . . . . B-1  
   factory defaults via Reset menu . . . . . 5-5  
   gateway, for IP address . . . . . C-5  
 default colors . . . . . 5-4  
 demod  
   marker to demod frequency . . . . . B-5  
   with beat frequency oscillator . . . . . B-3  
 DHCP  
   LAN connection . . . . . C-1  
   more information . . . . . C-5  
 display . . . . . 5-3  
 display area . . . . . 2-8  
 documents for Spectrum Master . . . . . 1-4  
 documents, reference . . . . . 1-6  
 Dynamic Host Configuration Protocol  
   see DHCP

### E

emergency repair . . . . . 7-7  
 error messages  
   Operation . . . . . B-2  
   Self Test . . . . . B-1  
 ESD cautions . . . . . 1-5  
 Ethernet  
   configuration . . . . . C-3  
   IP address . . . . . C-1  
   menu . . . . . C-4  
   menu, emergency repair . . . . . 7-8  
   updating firmware . . . . . 7-2  
 external power connector . . . . . 2-12  
 external reference port . . . . . 2-13  
 external trigger . . . . . 2-13

### F

factory defaults submenu key . . . . . 5-5  
 fan . . . . . 2-4, B-5  
 file management . . . . . 4-1  
 file menu . . . . . 4-7

firmware  
file not listed . . . . . 7-11  
ready or available . . . . . 7-10  
update OS key . . . . . 7-9  
updating problems . . . . . 7-7  
updating via Ethernet . . . . . 7-2  
updating via USB . . . . . 5-7, 7-2  
updating, main topic . . . . . 7-2

frequency  
bandwidth setting . . . . . 3-3  
external reference port . . . . . 2-13  
setting signal standard . . . . . 3-3  
setup the instrument . . . . . 3-3  
frequency blanking . . . . . 1-9  
frequency range . . . . . 1-1  
front panel keys . . . . . 2-4

**G**

gateway  
default, for IP address . . . . . C-5  
part of IP address . . . . . C-1

GPS  
antenna connector, type SMA . . . 2-13  
setting up . . . . . 6-1  
System menu . . . . . 5-1

**H**

headset jack . . . . . 2-12, 2-13  
high contrast . . . . . 5-4  
hold condition, no sweep . . . . . 2-15

**I**

IF Out port . . . . . 2-13  
instrument settings summary . . . . . 2-8  
IP address . . . . . C-1  
default gateway . . . . . C-5  
ping tool . . . . . C-7  
static . . . . . C-5  
static, emergency repair . . . . . 7-8  
subnet mask . . . . . C-5  
ipconfig tool . . . . . C-6

**J**

jack, headset . . . . . 2-13

**K**

key  
front panel keys . . . . . 2-4  
main menu keys . . . . . 2-5  
mode-dependent main menu keys 2-16  
submenu keys . . . . . 2-5

**L**

LAN and DHCP information . . . . . C-1  
LAN connection . . . . . 2-12, C-1  
latitude, GPS . . . . . 6-1  
LCD, Spectrum Master display . . . . . 1-4  
limit lines, setup . . . . . 3-6  
longitude, GPS . . . . . 6-1

**M**

main menu key labels . . . . . 2-8  
maintenance  
emergency repairs . . . . . 7-7  
preventive . . . . . 1-5  
markers, setup . . . . . 3-8  
mask, subnet, for IP address . . . . . C-5  
master reset  
memory and files . . . . . 1-11  
submenu key . . . . . 5-5  
Master Software Tools . . . . . 7-1  
updating firmware . . . . . 7-2  
measurement guides . . . . . A-1  
measurements  
selecting signal standard . . . . . 3-3  
setting amplitude . . . . . 3-4  
setting bandwidth . . . . . 3-3  
setting frequency . . . . . 3-3  
setting span . . . . . 3-5  
setting up GPS . . . . . 6-1  
setting up limit lines . . . . . 3-6  
setting up markers . . . . . 3-8

menu  
 copy ..... 4-12  
 delete ..... 4-13  
 Ethernet ..... 7-8, C-4  
 file ..... 4-7  
 Mode Selector ..... 2-6  
 Options, System ..... 5-3  
 Preset ..... 5-6  
 recall ..... 4-11  
 Reset ..... 5-5  
 save ..... 4-8  
 save location ..... 4-9  
 save on event ..... 4-10  
 System ..... 5-2  
 System Options ..... 5-3  
 system options ..... 5-4

menu map  
 System menus ..... 5-1

mode  
 bootstrap ..... 7-7  
 selector list box ..... 2-6

**N**

night vision ..... 5-4

**O**

operating system  
 windows support, MST ..... 7-1

optional data window ..... 2-8

OS Recovery window ..... 7-11

**P**

packaged items ..... 1-3  
 panel, keys on front ..... 2-4  
 parts replacement, service centers ... 1-6  
 ping tool ..... C-7  
 ports, test panel connectors ..... 2-12  
 power offset, share ..... 5-3  
 power, external connector ..... 2-12  
 Preset menu ..... 5-6  
 preventive maintenance ..... 1-5  
 problems  
 booting after updating firmware .. 7-7  
 updating firmware ..... 7-6  
 product updates window ..... 7-2

**R**

real time clock ..... 2-8  
 recall menu ..... 4-10, 4-11  
 recovery, OS ..... 7-11  
 reference documents ..... 1-6

reference level ..... B-2  
 refresh directories ..... 4-9  
 repair, emergency ..... 7-7  
 repairs, service centers ..... 1-6  
 reset  
 files erased ..... 1-11  
 menu ..... 5-5  
 RF connectors, cleaning ..... 1-5  
 RF In port ..... 2-13  
 run versus hold for sweep ..... 2-15

**S**

safety symbols  
 for safety ..... Safety-2  
 in manuals ..... Safety-1  
 on equipment ..... Safety-1

save menu ..... 4-8  
 secure data ..... 1-9  
 self test ..... 5-6  
 service centers ..... 1-6  
 signal standard, selecting ..... 3-3  
 single sweep ..... 2-15  
 SPA RF In ..... 2-13  
 span, setting ..... 3-5  
 stand, tilt bail ..... 1-9  
 standard accessories ..... 1-3  
 start and stop frequency settings .... 3-3  
 static IP address  
 emergency repair ..... 7-8  
 setting parameters ..... C-5  
 submenu key labels ..... 2-8  
 subnet ..... C-1  
 subnet mask, for IP address ..... C-5  
 sweep window ..... 2-8  
 System  
 menu ..... 5-2  
 menus, group ..... 5-1  
 system self test ..... 5-6

**T**

technical data sheet ..... 1-1  
 test panel connectors ..... 2-12  
 tilt bail ..... 1-9  
 trigger  
 external, connector ..... 2-12  
 external, description ..... 2-13

**U**

updates, product updates window .... 7-2

updating firmware  
  problems ..... 7-7  
  via Ethernet ..... 7-2  
  via USB .....5-7, 7-2

**USB**

  error, Beat Frequency Oscillator .. B-3  
  flash drive memory ..... 1-5  
  interface to PC ..... 2-13  
  Type A ..... 2-13  
  Type Mini-B ..... 2-13  
  updating firmware .....5-7, 7-2

**W**

WCDMA  
  automatic calibration ..... 1-5  
  windows operating system support, MST 7-1



# Anritsu

---



Anritsu Company Prints on Recycled Paper with Vegetable Soybean Oil Ink

Anritsu Company  
490 Jarvis Drive  
Morgan Hill, CA 95037-2809  
USA  
<http://www.anritsu.com/>