

Maintenance Manual

Spectrum Master™

MS2722C, MS2723C, MS2724C, MS2725C and MS2726C

High Performance Handheld Spectrum Analyzer

The Anritsu logo consists of the word "Anritsu" in a bold, sans-serif font. The letter "A" is stylized with a diagonal slash through it.

Anritsu Company
490 Jarvis Drive
Morgan Hill, CA 95037-2809
USA

Part Number: 10580-00279
Revision: A
Published: September 2010
Copyright 2010 Anritsu Company

www.valuetronics.com

WARRANTY

The Anritsu product(s) listed on the title page is (are) warranted against defects in materials and workmanship for one year from the date of shipment.

Anritsu's obligation covers repairing or replacing products which prove to be defective during the warranty period. Buyers shall prepay transportation charges for equipment returned to Anritsu for warranty repairs. Obligation is limited to the original purchaser. Anritsu is not liable for consequential damages.

LIMITATION OF WARRANTY

The foregoing warranty does not apply to Anritsu connectors that have failed due to normal wear. Also, the warranty does not apply to defects resulting from improper or inadequate maintenance by the Buyer, unauthorized modification or misuse, or operation outside of the environmental specifications of the product. No other warranty is expressed or implied, and the remedies provided herein are the Buyer's sole and exclusive remedies.

DISCLAIMER OF WARRANTY

DISCLAIMER OF WARRANTIES. TO THE MAXIMUM EXTENT PERMITTED BY APPLICABLE LAW, ANRITSU COMPANY AND ITS SUPPLIERS DISCLAIM ALL WARRANTIES, EITHER EXPRESS OR IMPLIED, INCLUDING, BUT NOT LIMITED TO, IMPLIED WARRANTIES OF MERCHANTABILITY AND FITNESS FOR A PARTICULAR PURPOSE, WITH REGARD TO THE SOFTWARE PRODUCT. THE USER ASSUMES THE ENTIRE RISK OF USING THE PROGRAM. ANY LIABILITY OF PROVIDER OR MANUFACTURER WILL BE LIMITED EXCLUSIVELY TO PRODUCT REPLACEMENT.

NO LIABILITY FOR CONSEQUENTIAL DAMAGES. TO THE MAXIMUM EXTENT PERMITTED BY APPLICABLE LAW, IN NO EVENT SHALL ANRITSU COMPANY OR ITS SUPPLIERS BE LIABLE FOR ANY SPECIAL, INCIDENTAL, INDIRECT, OR CONSEQUENTIAL DAMAGES WHATSOEVER (INCLUDING, WITHOUT LIMITATION, DAMAGES FOR LOSS OF BUSINESS PROFITS, BUSINESS INTERRUPTION, LOSS OF BUSINESS INFORMATION, OR ANY OTHER PECUNIARY LOSS) ARISING OUT OF THE USE OF OR INABILITY TO USE THE SOFTWARE PRODUCTS, EVEN IF ANRITSU COMPANY HAS BEEN ADVISED OF THE POSSIBILITY OF SUCH DAMAGES. BECAUSE SOME STATES AND JURISDICTIONS DO NOT ALLOW THE EXCLUSION OR LIMITATION OF LIABILITY FOR CONSEQUENTIAL OR INCIDENTAL DAMAGES, THE ABOVE LIMITATION MAY NOT APPLY TO YOU.

TRADEMARK ACKNOWLEDGMENTS

Windows, Windows XP, and Windows Vista all registered trademarks of Microsoft Corporation.
Acrobat Reader is a registered trademark of Adobe Corporation.
Spectrum Master is a trademark of Anritsu Company.

NOTICE

Anritsu Company has prepared this manual for use by Anritsu Company personnel and customers as a guide for the proper installation, operation and maintenance of Anritsu Company equipment and computer programs. The drawings, specifications, and information contained herein are the property of Anritsu Company, and any unauthorized use or disclosure of these drawings, specifications, and information is prohibited; they shall not be reproduced, copied, or used in whole or in part as the basis for manufacture or sale of the equipment or software programs without the prior written consent of Anritsu Company.

UPDATES

Updates, if any, can be downloaded from the Documents area of the Anritsu Website at:
<http://www.anritsu.com>

For the latest service and sales contact information in your area, please visit:
<http://www.anritsu.com/contact.asp>

DECLARATION OF CONFORMITY

Manufacturer's Name: ANRITSU COMPANY

Manufacturer's Address: Microwave Measurements Division
490 Jarvis Drive
Morgan Hill, CA 95037-2809
USA

declares that the product specified below:

Product Name: Spectrum Master

Model Numbers: MS2722C, MS2723C, MS2724C, MS2725C, MS2726C

conforms to the requirement of:

EMC Directive: 2004/108/EC
Low Voltage Directive: 2006/95/EC

Electromagnetic Compatibility: EN61326:2006

Emissions: EN55011: 2007 Group 1 Class A

Immunity:	EN 61000-4-2:1995 +A1:1998 +A2:2001	4 kV CD, 8 kV AD
	EN 61000-4-3:2006 +A1:2008	3 V/m
	EN 61000-4-4:2004	0.5 kV S-L, 1 kV P-L
	EN 61000-4-5:2006	0.5 kV L-L, 1 kV L-E
	EN 61000-4-6: 2007	3 V
	EN 61000-4-11: 2004	100% @ 20 ms

Electrical Safety Requirement:

Product Safety: EN 61010-1:2001

Morgan Hill, CA

Eric McLean, Corporate Quality Director

6 AUG 2010
Date

European Contact: For Anritsu product EMC & LVD information, contact Anritsu LTD, Rutherford Close, Stevenage Herts, SG1 2EF UK, (FAX 44-1438-740202)

Notes On Export Management

This product and its manuals may require an Export License or approval by the government of the product country of origin for re-export from your country.

Before you export this product or any of its manuals, please contact Anritsu Company to confirm whether or not these items are export-controlled.

When disposing of export-controlled items, the products and manuals need to be broken or shredded to such a degree that they cannot be unlawfully used for military purposes.

CE Conformity Marking

Anritsu affixes the CE Conformity marking onto its conforming products in accordance with Council Directives of The Council Of The European Communities in order to indicate that these products conform to the EMC and LVD directive of the European Union (EU).



C-tick Conformity Marking

Anritsu affixes the C-tick marking onto its conforming products in accordance with the electromagnetic compliance regulations of Australia and New Zealand in order to indicate that these products conform to the EMC regulations of Australia and New Zealand.



Mercury Notification

This product uses an LCD backlight lamp that contains mercury. Disposal may be regulated due to environmental considerations. Please contact your local authorities or, within the United States, the Electronics Industries Alliance (www.eiae.org) for disposal or recycling information.

European Parliament and Council Directive 2002/96/EC



Chinese RoHS Compliance Statement

产品中有毒有害物质或元素的名称及含量

For Chinese Customers Only NLNB

部件名称	有毒有害物质或元素					
	铅 (Pb)	汞 (Hg)	镉 (Cd)	六价铬 [Cr(VI)]	多溴联苯 (PBB)	多溴二苯醚 (PBDE)
印刷线路板 (PCA)	×	○	×	×	○	○
机壳、支架 (Chassis)	×	○	×	×	○	○
其他(电缆、风扇、 连接器等) (Appended goods)	×	○	×	×	○	○

○：表示该有毒有害物质在该部件所有均质材料中的含量均在 SJ/T11363-2006 标准规定的限量要求以下。
 ×：表示该有毒有害物质至少在该部件的某一均质材料中的含量超出 SJ/T11363-2006 标准规定的限量要求。

环保使用期限



这个标记是根据 2006/2/28 公布的「电子信息产品污染控制管理办法」以及 SJ/T 11364-2006 「电子信息产品污染控制标识要求」的规定，适用于在中国销售的电子信息产品的环保使用期限。仅限于在遵守该产品的安全规范及使用注意事项的基础上，从生产日起算的该年限内，不会因产品所含有害物质的泄漏或突发性变异，而对环境污染，人身及财产产生深刻地影响。

注) 生产日期标于产品序号的前四码(如 S/N 0728XXXX 为 07 年第 28 周生产)。

Safety Symbols

To prevent the risk of personal injury or loss related to equipment malfunction, Anritsu Company uses the following symbols to indicate safety-related information. For your own safety, please read the information carefully *before* operating the equipment.

Symbols Used in Manuals

Danger



This indicates a very dangerous procedure that could result in serious injury or death, and possible loss related to equipment malfunction, if not performed properly.

Warning



This indicates a hazardous procedure that could result in light-to-severe injury or loss related to equipment malfunction, if proper precautions are not taken.

Caution



This indicates a hazardous procedure that could result in loss related to equipment malfunction if proper precautions are not taken.

Safety Symbols Used on Equipment and in Manuals

The following safety symbols are used inside or on the equipment near operation locations to provide information about safety items and operation precautions. Ensure that you clearly understand the meanings of the symbols and take the necessary precautions *before* operating the equipment. Some or all of the following five symbols may or may not be used on all Anritsu equipment. In addition, there may be other labels attached to products that are not shown in the diagrams in this manual.



This indicates a prohibited operation. The prohibited operation is indicated symbolically in or near the barred circle.



This indicates a compulsory safety precaution. The required operation is indicated symbolically in or near the circle.



This indicates a warning or caution. The contents are indicated symbolically in or near the triangle.



This indicates a note. The contents are described in the box.



These indicate that the marked part should be recycled.

For Safety

Warning



Always refer to the operation manual when working near locations at which the alert mark, shown on the left, is attached. If the operation, etc., is performed without heeding the advice in the operation manual, there is a risk of personal injury. In addition, the equipment performance may be reduced.

Moreover, this alert mark is sometimes used with other marks and descriptions indicating other dangers.

Warning

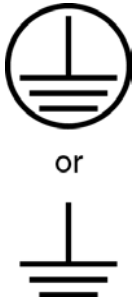

When supplying power to this equipment, connect the accessory 3-pin power cord to a 3-pin grounded power outlet. If a grounded 3-pin outlet is not available, use a conversion adapter and ground the green wire, or connect the frame ground on the rear panel of the equipment to ground. If power is supplied without grounding the equipment, there is a risk of receiving a severe or fatal electric shock.

Warning



This equipment can not be repaired by the operator. Do not attempt to remove the equipment covers or to disassemble internal components. Only qualified service technicians with a knowledge of electrical fire and shock hazards should service this equipment. There are high-voltage parts in this equipment presenting a risk of severe injury or fatal electric shock to untrained personnel. In addition, there is a risk of damage to precision components.

Warning



Use two or more people to lift and move this equipment, or use an equipment cart. There is a risk of back injury if this equipment is lifted by one person.

Caution



Electrostatic Discharge (ESD) can damage the highly sensitive circuits in the instrument. ESD is most likely to occur as test devices are being connected to, or disconnected from, the instrument's front and rear panel ports and connectors. You can protect the instrument and test devices by wearing a static-discharge wristband. Alternatively, you can ground yourself to discharge any static charge by touching the outer chassis of the grounded instrument before touching the instrument's front and rear panel ports and connectors. Avoid touching the test port center conductors unless you are properly grounded and have eliminated the possibility of static discharge.

Repair of damage that is found to be caused by electrostatic discharge is not covered under warranty.

Table of Contents

Chapter 1—General Information

1-1	Introduction	1-1
1-2	Anritsu Customer Service Centers	1-1
1-3	Recommended Test Equipment	1-2
1-4	Replaceable Parts	1-5

Chapter 2—Spectrum Analyzer Verification

2-1	Frequency Accuracy Verification	2-1
2-2	Single Side Band (SSB) Phase Noise Verification	2-3
2-3	Spurious Response (Second Harmonic Distortion) Verification	2-5
2-4	Input Related Spurious (IRS) Signals Verification	2-7
	1000 MHz Input Related Spurious Check	2-7
	3273 MHz Input Related Spurious Check:	2-8
	8000 MHz Input Related Spurious Check	2-8
2-5	Resolution Bandwidth Accuracy Verification	2-10
2-6	Spectrum Analyzer Absolute Amplitude Accuracy Verification.	2-12
	50 MHz Amplitude Accuracy Verification.	2-12
	Amplitude Accuracy Across Frequency Verification	2-15
	Measuring Amplitude Accuracy Across Frequency	2-16
2-7	Residual Spurious Response Verification.	2-18
	Residual Spurious Response Test with Preamp Off	2-18
	Residual Spurious Response Test with Preamp On	2-19
2-8	Displayed Average Noise Level (DANL).	2-20
	Preamp On Procedure.	2-20
	Preamp Off Procedure.	2-20
2-9	Third Order Intercept (TOI).	2-21
	2400 MHz TOI Test	2-21

Chapter 3—Options Verification

3-1	Introduction	3-1
3-2	Option 31, GPS Frequency Accuracy Verification	3-1
	GPS Option Bias-Tee Voltage Verification (Option 31)	3-3
3-3	Option 40 and/or 41, GSM/GPRS/EDGE Signal Analyzer Verification.	3-5
	GSM Burst Power, Frequency Error and Phase Error Tests.	3-6
	EDGE Burst Power, Frequency Error and Residual Error Tests.	3-8
3-4	Option 42 and/or 43, CDMA Signal Analyzer Verification.	3-10
	cdmaOne Channel Power, Frequency Error, Rho and Tau Tests.	3-11
	CDMA2000 Channel Power, Frequency Error, Rho and Tau Tests	3-12

Table of Contents (Continued)

3-5	Option 44, 45, and/or 65 WCDMA/HSDPA Signal Analyzer Verification	3-13
	WCDMA Absolute Power Accuracy Verification (Option 44)	3-13
	WCDMA Occupied Bandwidth (OBW) Verification (Option 44)	3-18
	WCDMA RF Channel Power Accuracy and ACLR Verification (Option 44)	3-20
	HSDPA RF Channel Power Accuracy and ACLR Verification (Option 44)	3-21
	Error Vector Magnitude (EVM) Verification (Option 45 or Option 65)	3-22
3-6	Option 46 and/or Option 47, Fixed WiMAX Signal Analyzer Verification	3-24
	Fixed WiMAX Channel Power Accuracy Tests (Option 46)	3-24
	Fixed WiMAX Residual EVM and Frequency Error Tests (Option 47)	3-26
3-7	Option 60 and/or Option 61, TDSCDMA Signal Analyzer Option Verification	3-28
	TDSCDMA Channel Power, Frequency Error, EVM, and Tau Test Procedure	3-29
3-8	Option 62 and/or Option 63, EVDO Signal Analyzer Option Verification	3-30
	8PSK Modulation Channel Power, Frequency Error, Rho, and Tau Tests	3-31
	QPSK Modulation Channel Power, Frequency Error, Rho, and Tau Tests	3-32
	16QAM Modulation Channel Power, Frequency Error, Rho, and Tau Tests	3-32
	Idle Slot Channel Power, Frequency Error, Rho, and Tau Tests	3-33
3-9	Option 66 and/or Option 67, Mobile WiMAX Signal Analyzer Verification	3-34
	Mobile WiMAX Channel Power Accuracy Tests (Option 66)	3-34
	Channel Power Accuracy (10 MHz Bandwidth and 10 ms Frame Length)	3-35
	Channel Power Accuracy (5 MHz Bandwidth and 5 ms Frame Length)	3-36
	Mobile WiMAX Residual EVM and Frequency Error Tests (Option 67)	3-38
	Residual EVM and Frequency Error (10 MHz Bandwidth and 10 ms Frame Length)	3-39
	Residual EVM and Frequency Error (5 MHz Bandwidth and 5 ms Frame Length)	3-40
3-10	LTE Signal Analyzer Option 541 and/or 542 and/or 543 Verification	3-41
	LTE Channel Power Accuracy Tests (Option 541 and 543)	3-42
	LTE Residual EVM and Frequency Error Tests (Option 542 and 543)	3-43

Chapter 4—Battery Information

4-1	General Information	4-1
4-2	Battery Pack Removal and Replacement	4-2

Chapter 5—Assembly Replacement

5-1	Replaceable Parts List	5-1
5-2	Opening the Spectrum Master Case	5-1
5-3	Spectrum Analyzer Module Assembly Replacement	5-5
5-4	Main PCB Assembly Replacement	5-6
5-5	LCD Assembly Replacement	5-8
5-6	Keypad Membrane and Main Keypad PCB Replacement	5-9
5-7	Function Key Membrane and Switchpad Replacement	5-12

Chapter 6—Troubleshooting

Table of Contents (Continued)

Appendix A—Test Records

A-1	Test Records for Spectrum Analyzer Verification	A-2
A-2	Test Records for Options Verification	A-35
	Option 31 GPS Receiver	A-35
	Option 40, GSM/GPRS/EDGE RF Measurements	A-35
	Option 40, GSM/GPRS/EDGE RF Measurements (Continued)	A-36
	Option 40, GSM/GPRS/EDGE RF Measurements (Continued)	A-37
	Option 41, GSM/GPRS/EDGE Demodulator	A-38
	Option 41, GSM/GPRS/EDGE Demodulator (Continued)	A-39
	Option 42 CDMA RF Measurements	A-40
	Option 43 cdmaOne and CDMA2000 1xRTT Demodulator	A-41
	Option 44 and/or 45 and/or 65 WCDMA and HSDPA RF Measurements	A-42
	Option 46 Fixed WiMAX RF Measurements	A-45
	Option 47 Fixed WiMAX Demodulator	A-46
	Option 60 or 61, TDSCDMA Signal Analyzer Option Verification	A-46
	Option 62, EVDO RF Measurements	A-47
	Option 63 EVDO Demodulator	A-48
	Option 66 Mobile WiMAX RF Measurements	A-50
	Option 66 Mobile WiMAX RF Measurements (Continued)	A-51
	Option 67 Mobile WiMAX Demodulator	A-52
	Option 541 and 543 LTE Measurements	A-53
	Option 542 and 543, LTE Measurements	A-54

Chapter 1 — General Information

1-1 Introduction

This manual provides maintenance instructions for Anritsu Spectrum Master Models MS2722C, MS2723C, MS2724C, MS2725C and MS2726C. It provides a list of recommended test equipment, performance verification procedures, parts replacement procedures, replaceable parts list and test records.

Familiarity with the basic operation of the front panel keys is assumed (for example, how to change measurement mode, how to preset the instrument, or the meaning of “submenu key”). Before making any measurement, ensure that all equipment has warmed up for at least 30 minutes.

The manual includes:

- General information in this chapter, including:
 - Lists of necessary test equipment to perform verification testing ([Table 1-1](#), [Table 1-2](#), and [Table 1-3](#))
 - Replaceable parts list ([Table 1-4](#))
- Performance verification procedures:
 - [Chapter 2, “Spectrum Analyzer Verification”](#)
 - [Chapter 3, “Options Verification ”](#)
- Battery pack information ([Chapter 4, “Battery Information”](#))
- Parts replacement procedures ([Chapter 5, “Assembly Replacement”](#))
- Troubleshooting problems ([Chapter 6, “Troubleshooting”](#))
- Blank test records are included in [Appendix A](#).
 - Copy the blank test records from [Appendix A](#) and use them to record measured values. These test records form a record of the performance of your instrument. Anritsu recommends that you make a copy of the blank test records to document the measurements each time a Performance Verification is performed. Continuing to document this process each time it is performed provides a detailed history of instrument performance, which can allow you to observe trends.

Caution Before making any measurement, verify that all equipment has warmed up for at least 30 minutes.
--

1-2 Anritsu Customer Service Centers

For the latest service and sales information in your area, please visit the following URL:

<http://www.anritsu.com/Contact.asp>

Choose a country for regional contact information.

1-3 Recommended Test Equipment

The following test equipment is recommended for use in testing and maintaining Anritsu Models MS2722C, MS2723C, MS2724C, MS2725C and MS2726C.

- [Table 1-1](#) is a list of test equipment that is required for verifying the spectrum analyzer functions on Models MS2722C, MS2723C and MS2724C.
- [Table 1-2](#) is a list of test equipment that is required for verifying the spectrum analyzer functions on Models MS2725C and MS2726C.
- [Table 1-3](#) is a list of test equipment that is required for verifying the functions of installed options on any MS272xC Model.
- [Table 1-4](#) is a list of replaceable parts for the MS272xC Spectrum Master.

Table 1-1. Test Equipment Required for Verifying Spectrum Analyzer Functions up to 20 GHz

Instrument	Critical Specification	Recommended Manufacturer/Model
Synthesized Signal Generator	Frequency: 0.1 Hz to 20 GHz, Power Output: +16 dBm, Step attenuator installed	Anritsu Model MG3692A or MG3692B with Options 2A, 4, 22, 15x ^a
Power Meter	Power Range: -70 to +20 dBm	Anritsu Model ML2438A
Power Sensor	Frequency: 100 kHz to 18 GHz Power Range: -67 to +20 dB	Anritsu Model MA2421D or SC7400 (Qty 2)
50 ohm Termination	Frequency: DC to 18 GHz	Anritsu Model 28N50-2
Adapter	Frequency: DC to 20 GHz N(m)-N(m), 50 ohm	Anritsu Model 34NN50A
Adapter	Frequency: DC to 20 GHz K(m)-N(f), 50 ohm	Anritsu Model 34RKNF50
RF Coaxial Cable	Frequency: DC to 18 GHz N(m)-N(f), 50 ohm	Anritsu Model 15NN50-1.5B (Qty 2)
Lowpass Filter	Frequency: 50 MHz	Anritsu Part Number 1030-96
Frequency Reference	Frequency: 10 MHz	Symmetricom RubiSource T&M
Signal Generator		Agilent Model 8648D with Options 1ES and 1EA
Fixed Attenuator	10 dB Attenuation	Aeroflex/Weinschel Model 44-10 (Qty 2)
Fixed Attenuator	20 dB Attenuation	Aeroflex/Weinschel Model 44-20 (Qty 2)
Fixed Attenuator	6 dB Attenuation	Aeroflex/Weinschel Model 44-6 (Qty 2)
Fixed Attenuator	2 dB Attenuation	Aeroflex/Weinschel Model 44-2 (Qty 2)
Power Splitter	Frequency: DC to 18 GHz	Aeroflex/Weinschel Model 1870A
Coaxial Cable	BNC(m) to BNC(m), 50 ohm	Any (Qty 2)

a. Note that MG3692A models require Option 15 to achieve power of +16 dBm at 3.5 GHz. MG3692B models do not require Option 15 to achieve power of +16 dBm at 3.5 GHz.

Caution

Factory tests have shown that the equipment that is listed above will provide satisfactory results at 20 GHz (the upper limit of the MS2724C) even though the chart above specifies 18 GHz (per manufacturers specifications). Many Type N cables have excessive loss for testing the spectrum analyzer section of the instrument up to 20 GHz. An SMA cable or K cable should therefore be installed on the MG synthesizer for all spectrum analyzer tests on the MS2724C.

Table 1-2. Test Equipment Required for Verifying Spectrum Analyzer Functions up to 40 GHz

Instrument	Critical Specification	Recommended Manufacturer/Model
Synthesized Signal Generator	Frequency: 0.1 Hz to 20 GHz, Power Output: +16 dBm, Step attenuator installed	Anritsu Model MG3692A or MG3692B with Options 2A, 4, 22, 15 ^b
Synthesized Signal Generator	Frequency: 0.1 Hz to 40 GHz, Power Output: +16 dBm, Step attenuator installed	Anritsu Model MG3692A or MG3695C with Options 2A, 4, 22, 15 ^b
Power Meter	Power Range: -70 to +20 dBm	Anritsu Model ML2438A
Power Sensor	Frequency: 100 kHz to 40 GHz Power Range: -70 to +20 dB	Anritsu Model SC7413 (Qty 2) K type
50 ohm Termination	Frequency: DC to 40 GHz	Anritsu Model 28KF50-2
Adapter	Frequency: DC to 40 GHz K(m)-K(m), 50 ohm	Anritsu Model K220B
Adapter	Frequency: DC to 40 GHz K(f)-K(f), 50 ohm	Anritsu Model K222B
RF Coaxial Cable	Frequency: DC to 40 GHz K(m)-K(f), 50 ohm	Anritsu Model 3670K50-2 (Qty 2)
Lowpass Filter	Frequency: 50 MHz	Anritsu Part Number 1030-96
Frequency Reference	Frequency: 10 MHz	Symmetricom RubiSource T&M
Signal Generator		Agilent Model 8648D with Options 1ES and 1EA
Fixed Attenuator	10 dB Attenuation	Aeroflex/Weinschel Model 44-10 (Qty 2)
Fixed Attenuator	10 dB Attenuation	Anritsu Model 41KC-10
Fixed Attenuator	20 dB Attenuation	Aeroflex/Weinschel Model 44-20 (Qty 2)
Fixed Attenuator	6 dB Attenuation	Aeroflex/Weinschel Model 44-6 (Qty 2)
Fixed Attenuator	2 dB Attenuation	Aeroflex/Weinschel Model 44-2 (Qty 2)
Power Splitter	Frequency: DC to 18 GHz	Aeroflex/Weinschel Model 1870A
Power Splitter	Frequency: DC to 40 GHz	Anritsu Model K241C
Coaxial Cable	BNC(m) to BNC(m), 50 ohm	Any (Qty 2)
Adapter	K(f) to N(f), 50 ohms, Ruggedized	Anritsu Model 71693-R

b. Note that MG3692A models require Option 15 to achieve power of +16 dBm at 3.5 GHz. MG3692B models do not require Option 15 to achieve power of +16 dBm at 3.5 GHz.

Caution

Factory tests have shown that the equipment that is listed above will provide satisfactory results at 43 GHz (the upper limit of the MS2726C) even though the chart above specifies 40 GHz (per manufacturers specifications).

Table 1-3. Test Equipment Required for Verifying Functions of Installed Options (1 of 2)

Instrument	Critical Specification	Recommended Manufacturer/Model
Synthesizer	Frequency: 0.1 Hz to 20 GHz, +16 dBm power	Anritsu Model MG3692A or MG3692B with options 2A, 4, 15, and 22 ^c
Vector Signal Generator	Frequency: 100 kHz to 3 GHz	Anritsu Model MG3700A with Options MG3700A-002 and MG3700A-021 ^d
Power Meter	Power Range: -70 to + 20 dBm	Anritsu Model ML2438A
Power Sensor	Frequency: 10 MHz to 18 GHz Power Range: -60 to +20 dBm	Anritsu Model MA2482D with Option 1 (Qty 2)
Frequency Counter	Frequency: 20 GHz	Anritsu Model MF2412B
Programmable Attenuator	Frequency: DC to 2 GHz Attenuation: 100 dB (1 and 10 dB steps)	Anritsu Model MN63A
Fixed Attenuator	Frequency Range: DC to 18 GHz Attenuation: 10 dB	Aeroflex/Weinschel Model 44-10 (Qty 2)
Power Splitter	Frequency: DC to 18 GHz	Aeroflex/Weinschel Model 1870A
RF Power Amplifier	Frequency: 100 to 1000 MHz Gain: 35 dB min	Mini Circuits Model TIA-1000-1R8 (Qty 2 BNC(m) to N(f) Adapters required)
Adapter	Frequency: DC to 20 GHz N(m)-N(m), 50 ohm	Maury Microwave Model 8828B Quantity: 2 each [One each required only if Anritsu Coupler and Circulator are used]
Adapter	Frequency: DC to 20 GHz K(m)-N(f), 50 ohm	Anritsu Model 34RKNF50
Adapter	Frequency: 881.5 MHz BNC(m) to N(f), 50 ohm	Midwest Microwave Model ADT-2615-NF-BNM-02 (Qty 2)
Adapter	Frequency: 881.5 MHz SMA(m) to N(f), 50 ohm	Midwest Microwave Model ADT-2582-NF-SMM-02 (Qty: 4) [Required only if Anritsu Coupler and Circulator are used.]
Adapter	Frequency: 881.5 MHz SMA(m) to SMA(m), 50 ohm	Midwest Microwave Model ADT-2594-MM-SMA-02 [Required only if Anritsu Coupler and Circulator are used.]
50 ohm Termination	Frequency: DC to 18 GHz	Anritsu Model 28N50-2
High Power Load	DC to 18 GHz, 10W	Aeroflex/Weinschel Model M1418
Coupler	Frequency: 881.5 MHz Coupling Factor: 30 dB	Midwest Microwave Model CPW-5140-30-NNN-05 or CPW-5141-30-NNN-05 Alternative: Anritsu part number 1091-307 [Two SMA(m) to N(f) adapters required.]
Circulator	Frequency Range: 800 to 1000 MHz Isolation: 20 dB min	Meca Electronics, Inc. part number CN-0.900 Alternative: Anritsu part number 1000-50 [Two SMA(m) to N(f) adapter and one SMA(m) to SMA(m) Adapter required.]
RF Coaxial Cable	Frequency: DC to 18 GHz N(m)-N(m), 50 ohm	Anritsu Model 15NN50-1.5B (Qty 3)

Table 1-3. Test Equipment Required for Verifying Functions of Installed Options (2 of 2)

Instrument	Critical Specification	Recommended Manufacturer/Model
GPS Antenna		Anritsu 2000-1410
Coaxial Cable	BNC(m) to BNC(m), 50 ohm	Any
Adapter	K(f) to N(f), 50 ohms, Ruggedized	Anritsu Model 71693-R

c. Note that MG3692A models require Option 15 to achieve power of +13 dBm. MG3692B models do not require Option 15 to achieve +13 dBm power.

d Note that the MG3700A requires that several factory custom test pattern files be installed into its memory.

1-4 Replaceable Parts

Table 1-4. List of Replaceable Parts (1 of 2)

Part Number	Description
ND72062	MS2722C Main PCB Assembly, with Opt 9 ^e
ND72063	MS2723C Main PCB Assembly, with Opt 9 ^e
ND72064	MS2724C Main PCB Assembly, with Opt 9 ^e
ND72065	MS2725C Main PCB Assembly, with Opt 9 ^e
ND72066	MS2726C Main PCB Assembly, with Opt 9 ^e
ND72070	MS2725C and MS2726C Spec Analyzer PCB Assembly
ND72069	MS2724C Spec Analyzer PCB Assembly
ND72068	MS2722C and MS2723C Spec Analyzer PCB Assembly
ND70320	MS272xC GPS Receiver PCB (Opt 31)
3-790-661	Gasket material for case edge
3-15-154	LCD Display
3-61368	Clear Plastic LCD Protector
65729	Soft Carrying Case
3-68100-1	Case Top (excludes model ID Label and keypad items)
3-61365-1	Case Bottom (excluding Tilt Bail)
ND69107	Case Bottom including Tilt Bail
3-65314	Left and Right Tilt Bail (Plastic) Holders
3-65316	Tilt Bail Stand (Metal)
3-65684	Tilt Bail (Plastic) Clip
3-68108	Model MS2722C ID Label
3-68107	Model MS2723C ID Label
3-68106	Model MS2724C ID Label
3-68105	Model MS2725C ID Label
3-68104	Model MS2726C ID Label
61379-1	Battery Door
633-44	Li-ion Battery Pack
510-87	Type N RF Input connector
3-71353	Type K(m) Rugged RF Input connector

Table 1-4. List of Replaceable Parts (2 of 2)

Part Number	Description
ND70948	Fan
40-168-R	AC to DC Power Converter
3-71027-3	Main Keypad PCB
3-61362	Main Keypad (Rubber)
3-61363-1	Main Keyboard Bezel
3-61361	Soft keys Keypad (Rubber)
3-61378-1	Soft key Bezel
3-71030-3	Soft key PCB
790-625	Speaker
3-410-101	Encoder (excluding knob)
3-61360-2	Knob (excluding encoder)

e. When ordering the Main PCB Assembly, in order to ensure installation of correct options, all options that are installed on the instrument must be declared on the order. The options are listed on a label on the top of the MS272xC and are also shown in the **System** (Shift-8) / Status display.

Chapter 2 — Spectrum Analyzer Verification

2-1 Frequency Accuracy Verification

The following test is used to verify the CW frequency accuracy of the Spectrum Analyzer in the MS272xC Spectrum Master.

Equipment Required for MS2722C, MS2723C and MS2724C

- Anritsu MG3692X Synthesized Signal Source
- Frequency Reference Symmetricom Rubisource T&M
- Anritsu 34RKNF50 50 ohm Adapter
- Anritsu 15NN50-1.5C RF Coaxial Cable
- BNC male to BNC male Coaxial Cable

Equipment Required for MS2725C and MS2726C

- Anritsu MG3695C with option 2,3,4,15,22 Synthesized Signal Source
- Frequency Reference Symmetricom Rubisource T&M
- Anritsu 34VKF50 50 ohm Adapter
- Anritsu 3670K50-2 RF Coaxial Cable
- BNC male to BNC male Coaxial Cable

Procedure

1. Connect the 10 MHz Reference source to the Anritsu MG3692X or MG3695C Synthesized Signal Source.

Note Do not connect the external 10 MHz Reference to the Spectrum Master.
--

2. Turn on the 10 MHz Reference Standard and the Anritsu MG3692X or MG3695C Synthesized Signal Source.
3. Set the MG3692X or MG3695C output to 1 GHz CW, with an RF Output Level of -30 dBm.
4. Connect the output of the source to the RF Input of the Spectrum Master.
5. Turn on the Spectrum Master.
6. Press the **Shift** key and then the **Mode** (9) key. Rotate the knob to highlight Spectrum Analyzer and then press the **Enter** key to switch to Spectrum Analyzer mode.
7. Press the **Shift** key, the **Preset** (1) key, and then the Preset submenu key to reset the instrument to the default starting conditions. Press the **Shift** key, the **Sweep** (3) key, Sweep Mode submenu key and then the Performance submenu key.
8. Press the **Amplitude** main menu key and then press the Reference Level submenu key.
9. Use the keypad to enter -10 and select the dBm submenu key.
10. Press the **Span** main menu key, use the keypad to enter 10, and select the kHz submenu key.
11. Press the **BW** main menu key and select the RBW submenu key.
12. Use the keypad to enter 100 and select the Hz submenu key.
13. Press the VBW submenu key, use the keypad to enter 30 and then select the Hz submenu key.
14. Press the **Freq** main menu key and select the Center Freq submenu key.
15. Use the keypad to enter 1 and select the GHz submenu key.

16. Press the **Marker** main menu key, select the **More** submenu key, set Counter Marker to On, select the **Back** submenu key and select the **Peak Search** submenu key.
17. Verify that the marker frequency is $1\text{ GHz} \pm 300\text{ Hz}$ ($\pm 0.3\text{ ppm}$) and record in [Table A-1](#), “[Spectrum Analyzer Frequency Accuracy](#)” on [page A-2](#).
18. Set the MG3692X or MG3695C frequency to:
 - 7 GHz for MS2722C
 - 12 GHz for MS2723C
 - 18 GHz for MS2724C
 - 30 GHz for MS2725C
 - 40 GHz for MS2726C
19. Set the MS272xC center frequency to:
 - 7 GHz for MS2722C
 - 12 GHz for MS2723C
 - 18 GHz for MS2724C
 - 30 GHz for MS2724C
 - 40 GHz for MS2724C
20. Press the **Marker** main menu key, and select the **Peak Search** submenu key.
21. Verify that the marker frequency is:
 - $7\text{ GHz} \pm 2.1\text{ kHz}$ ($\pm 0.3\text{ ppm}$) for MS2722C
 - $12\text{ GHz} \pm 3.6\text{ kHz}$ ($\pm 0.3\text{ ppm}$) for MS2723C
 - $18\text{ GHz} \pm 5.4\text{ kHz}$ ($\pm 0.3\text{ ppm}$) for MS2724C
 - $30\text{ GHz} \pm 9.0\text{ kHz}$ ($\pm 0.3\text{ ppm}$) for MS2725C
 - $40\text{ GHz} \pm 12.0\text{ kHz}$ ($\pm 0.3\text{ ppm}$) for MS2726C
22. Record the results in the test records. Use [Table A-1](#).

Note

If the unit fails the Spectrum Analyzer Frequency Accuracy test, replace the SPA PCB assembly. Refer to “[Spectrum Analyzer Module Assembly Replacement](#)” on [page 5-5](#).

2-2 Single Side Band (SSB) Phase Noise Verification

This test is used to verify the single side band (SSB) phase noise of the spectrum analyzer in the MS272xC Spectrum Master.

Equipment Required for MS2722C, MS2723C and MS2724C

- Anritsu MG3692X Synthesized Signal Source
- Frequency Reference Symmetricom Rubisource T&M
- Anritsu 34RKNF50 50 ohm Adapter
- Anritsu 15NN50-1.5C RF Coaxial Cable
- BNC male to BNC male Coaxial Cable

Equipment Required for MS2725C and MS2726C

- Anritsu MG3695C with option 2,3,4,15,22 Synthesized Signal Source
- Frequency Reference Symmetricom Rubisource T&M
- Anritsu 34VKF50 50 ohm Adapter
- Anritsu 3670K50-2 RF Coaxial Cable
- BNC male to BNC male Coaxial Cable

Procedure

1. Connect the 10 MHz reference source to the Anritsu MG3692X or MG3695C Synthesized Signal Source.
2. Turn on the 10 MHz reference source and the Anritsu MG3692X or MG3695C Synthesized Signal Source.
3. Set the MG3692X or MG3695C output to 1.0 GHz CW, with an RF output level of +4 dBm.
4. Connect the output of the MG3692X or MG3695C Synthesized Signal Source to the RF In connector of the Spectrum Master.
5. Turn on the Spectrum Master.
6. Press the **Shift** key and then the **Mode** (9) key. Rotate the knob to highlight Spectrum Analyzer and then press the **Enter** key to switch to Spectrum Analyzer mode.
7. Press the **Shift** key, the **Preset** (1) key, and then the **Preset** submenu key to reset to the default starting conditions. Press the **Shift** key, the **Sweep** (3) key, press the **Sweep Mode** submenu key and then the **Performance** submenu key.
8. Press the **Amplitude** main menu key, then press the **Reference Level** submenu key.
9. Use the keypad to enter 5 and select the **dBm** submenu key.
10. Press the **Atten Lvl** submenu key, use the keypad to enter 15 and press the **dB** submenu key.
11. Press the **Freq** main menu key and select the **Center Freq** submenu key.
12. Use the keypad to enter 1.0 and press the **GHz** submenu key.
13. Press the **Span** main menu key, use the keypad to enter 110, and select the **kHz** submenu key.
14. Press the **BW** main menu key and select the **RBW** submenu key.
15. Use the keypad to enter 1 and select the **kHz** submenu key.
16. Press the **VBW** submenu key and use the keypad to enter 3, then select the **Hz** submenu key.
17. Press the **Shift** key and then press the **Trace** (5) key, then select the **Trace A Operations** submenu key.
18. Press the **# of Averages** submenu key, use the keypad to enter 3, then press the **Enter** key.
19. Wait until the Trace Count displays 3/3.
20. Press the **Marker** main menu key and select the **Peak Search** submenu key.

21. Press the Delta On/Off submenu key to turn Delta on.
22. Use the keypad to enter 10 and press the kHz submenu key.
23. Enter the measured value into [Table A-2, “Spectrum Analyzer 1.0 GHz SSB Phase Noise Verification” on page A-2.](#)
24. Subtract 30 dB from the average value and record the Calculated Value results in [Table A-2](#) and verify that the result is less than the specification for 10 kHz Offset.

For example: $-70 \text{ dBc measured} - 30 \text{ dB} = -100 \text{ dBc/Hz}$

25. Press the **Span** main menu key, use the keypad to enter 210, and select the kHz submenu key.
26. Press the **Shift** key and then press the **Trace** (5) key, then select the Trace A Operations submenu key.
27. Press the # of Averages submenu key, use the keypad to enter 3, then press the **Enter** key.
28. Wait until the Trace Count displays 3/3.
29. Press the **Marker** main menu key and select the Peak Search submenu key.
30. Press the Delta On/Off submenu key to turn Delta on.
31. Use the keypad to enter 100 and press the kHz submenu key.
32. Enter the measured value into [Table A-2.](#)
33. Subtract 30 dB from the average value and record the Calculated Value results in [Table A-2](#) and verify that the result is less than the specification for 100 kHz Offset.

For example: $-70 \text{ dBc measured} - 30 \text{ dB} = -100 \text{ dBc/Hz}$

34. Press the **Span** main menu key, use the keypad to enter 2.2, and select the MHz submenu key.
35. Press the VBW submenu key and use the keypad to enter 30, then select the Hz submenu key.
36. Press the **Shift** key and then press the **Trace** (5) key, then select the Trace A Operations submenu key.
37. Press the # of Averages submenu key, use the keypad to enter 3, then press the **Enter** key.
38. Wait until the Trace Count displays 3/3.
39. Press the **Marker** main menu key and select the Peak Search submenu key.
40. Press the Delta On/Off submenu key to turn Delta on.
41. Use the keypad to enter 1 and press the MHz submenu key.
42. Enter the measured value into [Table A-2.](#)
43. Subtract 30 dB from the average value and record the Calculated Value results in [Table A-2](#) and verify that the result is less than the specification for 1 MHz Offset.

For example: $-70 \text{ dBc measured} - 30 \text{ dB} = -100 \text{ dBc/Hz}$

44. Press the **Span** main menu key, use the keypad to enter 22, and select the MHz submenu key.
45. Press the **Shift** key and then press the **Trace** (5) key, then select the Trace A Operations submenu key.
46. Press the # of Averages submenu key, use the keypad to enter 3, then press the **Enter** key.
47. Wait until the Trace Count displays 3/3.
48. Press the **Marker** main menu key and select the Peak Search submenu key.
49. Press the Delta On/Off submenu key to turn Delta on.
50. Use the keypad to enter 10 and press the MHz submenu key.
51. Enter the measured value into [Table A-2.](#)
52. Subtract 30 dB from the average value and record the Calculated Value results in [Table A-2](#) of the test records and verify that the result is less than the specification for 10 MHz Offset.

For example: $-70 \text{ dBc measured} - 30 \text{ dB} = -100 \text{ dBc/Hz}$

2-3 Spurious Response (Second Harmonic Distortion) Verification

The following test is used to verify the input related spurious response of the spectrum analyzer in the MS272xC Spectrum Master.

Equipment Required for MS2722C, MS2723C and MS2724C

- Anritsu MG3692X Synthesized Signal Source
- Frequency Reference Symmetricom Rubisource T&M
- Anritsu 1030-96 50 MHz Low Pass Filter
- Anritsu 34RKNF50 50 ohm Adapter
- Anritsu 15NN50-1.5C RF Coaxial Cable
- BNC male to BNC male Coaxial Cable

Equipment Required for MS2725C and MS2726C

- All of the above
- Anritsu 71693-R Ruggedized K(f) to N(f) Adapter

Procedure

1. Connect the 10 MHz reference source to the Anritsu MG3692X or MS3695B Synthesized Signal Source.
2. Turn on the 10 MHz reference source and the Anritsu MG3692X or MS3695B Synthesized Signal Source.
3. Set the MG3692X output to 50.1 MHz CW, with an RF Output Level of -30 dBm.
4. Connect one end of the 50 MHz Low Pass Filter to the output of the source and the other end to the MS272xC RF Input with the coaxial cable.
5. Turn on the MS272xC.
6. Press the **Shift** key and then the **Mode** (9) key. Rotate the knob to highlight Spectrum Analyzer and then press the **Enter** key to switch to Spectrum Analyzer mode.
7. Press the **Shift** key, the **Preset** (1) key, and then the **Preset** submenu key to reset to the default starting conditions. Press the **Shift** key, the **Sweep** (3) key, **Sweep Mode** submenu key and then the **Performance** submenu key.
8. Press the **Amplitude** main menu key and then press the **Reference Level** submenu key.
9. Use the keypad to enter -27 and press the **dBm** submenu key.
10. Press the **Atten Lvl** submenu key and enter 0, then press the **dB** submenu key.
11. Press the **Freq** main menu key and select the **Center Freq** submenu key.
12. Use the keypad to enter 50.1 and press the **MHz** submenu key.
13. Press the **Span** main menu key, use the keypad to enter 100, and select the **kHz** submenu key.
14. Press the **BW** main menu key and select the **RBW** submenu key.
15. Use the keypad to enter 1 and select the **kHz** submenu key.
16. Press the **VBW** submenu key. Use the keypad to enter 10 and then select the **Hz** submenu key.
17. Press the **Amplitude** main menu key.
18. Press the **Detection** submenu key, and then the **Peak** submenu key.
19. Press the **Shift** key and then press the **Trace** (5) key, then select the **Trace A Operations** submenu key.
20. Press the **# of Averages** submenu key, use the keypad to enter 5 and then press the **Enter** key.
21. Wait until the Trace Count displays 5/5.
22. Press the **Marker** main menu key and select the **Peak Search** submenu key.

23. Record the amplitude for 50.1 MHz. Use [Table A-3, "Spectrum Analyzer Second Harmonic Distortion" on page A-2](#).
24. Press the **Freq** main menu key and select the Center Freq submenu key.
25. Use the keypad to enter 100.2 and press the MHz submenu key.
26. Press the **Shift** key and then press the **Trace** (5) key, then select the Trace A Operations submenu key.
27. Press the # of Averages submenu key, use the keypad to enter 5 and then press the **Enter** key.
28. Wait until the Trace Count displays 5/5.
29. Press the **Marker** main menu key and select the Peak Search submenu key.
30. Record the amplitude for 100.2 MHz in the test records. Use [Table A-3](#).
31. Calculate the 2nd Harmonic level in dBc by subtracting the 50.1 MHz amplitude from the 100.2 MHz amplitude using this formula:
Second Harmonic Level Amplitude @ 100.2 MHz = 100.2 MHz amplitude – 50.1 MHz amplitude = _____ dBc
32. Verify that the calculated Second Harmonic Level is within the specs listed below for the applicable model under test and record in the test records. Use [Table A-3](#).
 - For MS2722C ≤ -54 dBc
 - For MS2723C ≤ -54 dBc
 - For MS2724C ≤ -54 dBc
 - For MS2725C ≤ -54 dBc
 - For MS2726C ≤ -50 dBc

2-4 Input Related Spurious (IRS) Signals Verification

The following test is used to verify the input related spurious signals of the spectrum analyzer in the MS272xC at different frequencies.

Equipment Required for MS2722C, MS2723C and MS2724C

- Anritsu MG3692X Synthesized Signal Source
- Frequency Reference Symmetricom Rubisource T&M
- Anritsu 34VKF50 50 ohm Adapter
- Anritsu 15NN50-1.5C RF Coaxial Cable
- BNC male to BNC male Coaxial Cable

Equipment Required for MS2725C and MS2726C

- Anritsu MG3695C with option 2,3,4,15C,22 Synthesized Signal Source
- Frequency Reference Symmetricom Rubisource T&M
- Anritsu 34KFKF50 50 ohm Adapter
- Anritsu 3670K50-2 RF Coaxial Cable
- BNC male to BNC male Coaxial Cable

Procedure

1. Connect the 10 MHz reference source to the MG3692x or MG3695C Synthesized Signal Generator.
2. Connect the output of the Signal Generator to the Spectrum Analyzer RF In connector.

1000 MHz Input Related Spurious Check

3. Set the MG3692x or MG3695C output to 1000 MHz CW, with an RF output level of -30 dBm.
4. Set the MS272xC to Spectrum Analyzer mode and then Preset the instrument. Press the **Shift** key, the **Sweep** (3) key, Sweep Mode submenu key and then the Performance submenu key.
5. Press the **Amplitude** key, then press the Reference Level submenu key.
6. Use the keypad to enter -27 , and press the dBm submenu key.
7. Press the Atten Lvl submenu key and enter 0, then press the dB submenu key.
8. Press the Detection submenu key and the Peak submenu key.
9. Press the **Freq** key and press the Center Freq submenu key.
10. Use the keypad to enter 1000, and press the MHz submenu key.
11. Press the **Span** key, use the keypad to enter 2, and press the MHz submenu key.
12. Press the **BW** key and press the RBW submenu key.
13. Use the keypad to enter 1, and press the kHz submenu key.
14. Press the VBW submenu key and use the keypad to enter 100, then press the Hz submenu key.
15. Wait until one sweep is completed.
16. Press the **Marker** main menu key and press the Peak Search submenu key.
17. Record the Marker 1 amplitude reading for 1000 MHz into the “Measured Spur Level” column of [Table A-4, “Measured Input Signal Level at 1000 MHz” on page A-3.](#)
18. Press the **Freq** key and press the Start Freq submenu key.
19. Use the keypad to enter 719, and press the MHz submenu key.
20. Press Stop Freq submenu key, enter 721, and press the MHz submenu key.

21. Press the **Marker** main menu key and press the **Peak Search** submenu key.
22. Record the Marker 1 amplitude reading into the “Measured Spur Level” column of [Table A-4](#).
23. Calculate the input related spurious level by subtracting the Marker 1 reading in Step 17 from the Marker 1 reading in Step 22. Record the result into the “Calculated IRS” column of [Table A-4](#).
24. Verify that the calculated result is ≤ -60 dBc.

3273 MHz Input Related Spurious Check:

25. Set the MG3692x or MG3695C output to 3273 MHz, with an RF output level of -30 dBm.
26. On the MS272xC, press the **Freq** key and press the **Center Freq** submenu key.
27. Use the keypad to enter 3273, and press the **MHz** submenu key.
28. Press the **BW** key and press the **RBW** submenu key.
29. Use the keypad to enter 10, and press the **kHz** submenu key.
30. Press the **VBW** submenu key and use the keypad to enter 1, then press the **kHz** submenu key.
31. Wait until one sweep is completed.
32. Press the **Shift** key and then press the **Trace** (5) key. Press the **Trace A Operations** submenu key.
33. Press the **# of Averages** submenu key, use the keypad to enter 5, and then press the **Enter** key.
34. Wait until the Trace Count displays 5/5.
35. Press the **Marker** main menu key and press the **Peak Search** submenu key.
36. Record the amplitude at 3273 MHz into the “Measured Spur Level” column of [Table A-5](#), “Measured Input Signal Level at 3273 MHz” on page A-3.
37. Press the **Freq** key and press the **Start Freq** submenu key.
38. Use the keypad to enter 2423, and press the **MHz** submenu key.
39. Press **Stop Freq** submenu key, enter 3271, and press the **MHz** submenu key.
40. Press the **Shift** key and then press the **Trace** (5) key. Press the **Trace A Operations** submenu key.
41. Press the **# of Averages** submenu key, use the keypad to enter 5, and then press the **Enter** key.
42. Wait until the Trace Count displays 5/5.
43. Press the **Marker** main menu key and press the **Peak Search** submenu key.
44. Record the Marker 1 amplitude reading into the “Measured Spur Level” column of [Table A-5](#).
45. Calculate the input related spurious level by subtracting the Marker 1 reading in Step 36 from the Marker 1 reading in Step 44. Record the result into the “Calculated IRS” column of [Table A-5](#).
46. Verify that the calculated result is ≤ -60 dBc.
47. Repeat Step 37 through Step 45, setting a start frequency of 3275 MHz and a stop frequency of 4123 MHz.

8000 MHz Input Related Spurious Check

48. Set the MG3692x or MG3695C output to 8000 MHz, with an RF output level of -30 dBm.
49. Press the **Freq** key and press the **Center Freq** submenu key.
50. Use the keypad to enter 8000, and press the **MHz** submenu key.
51. Press the **BW** key and press the **RBW** submenu key.
52. Use the keypad to enter 1, and press the **kHz** submenu key.
53. Press the **VBW** submenu key and use the keypad to enter 100, then press the **Hz** submenu key.
54. Wait until one sweep is completed.

55. Press the **Shift** key and then press the **Trace** (5) key. Press the Trace A Operations submenu key.
56. Press the # of Averages submenu key, use the keypad to enter 5, and then press the **Enter** key.
57. Wait until the Trace Count displays 5/5.
58. Press the **Marker** main menu key and press the Peak Search submenu key.
59. Record the amplitude at 8000 MHz into the “Measured Spur Level” column of [Table A-6](#), “Measured Input Signal Level at 8000 MHz” on page A-3.
60. Press the **Freq** key and press the Start Freq submenu key.
61. Use the keypad to enter 7719, and press the MHz submenu key.
62. Press Stop Freq submenu key, enter 7721, and press the MHz submenu key.
63. Press the **Shift** key and then press the **Trace** (5) key. Press the Trace A Operations submenu key.
64. Press the # of Averages submenu key, use the keypad to enter 5, and then press the **Enter** key.
65. Wait until the Trace Count displays 5/5.
66. Press the **Marker** main menu key and press the Peak Search submenu key.
67. Record the Marker 1 amplitude reading into the “Measured Spur Level” column of [Table A-6](#).
68. Calculate the input related spurious level by subtracting the Marker 1 reading in Step 59 from the Marker 1 reading in Step 67. Record the result into the “Calculated IRS” column of [Table A-6](#).
69. Verify that the calculated result is ≤ -60 dBc.

15000 MHz Input Related Spurious Check (For MS2724C, MS2725C, MS2726C Only):

70. Set the MG3692x or MG3695C output to 15000 MHz, with an RF output level of -30 dBm.
71. Press the **Freq** key and press the Center Freq submenu key.
72. Use the keypad to enter 15000, and press the MHz submenu key.
73. Press the **Shift** key and then press the **Trace** (5) key. Press the Trace A Operations submenu key.
74. Press the # of Averages submenu key, use the keypad to enter 5, and then press the **Enter** key.
75. Wait until the Trace Count displays 5/5.
76. Press the **Marker** main menu key and press the Peak Search submenu key.
77. Record the amplitude at 15000 MHz into the “Measured Spur Level” column of [Table A-7](#), “Measured Input Signal Level at 15000 MHz” on page A-3.
78. Press the **Freq** key and press the Start Freq submenu key.
79. Use the keypad to enter 14719, and press the MHz submenu key.
80. Press Stop Freq submenu key, enter 14721, and press the MHz submenu key.
81. Press the **Shift** key and then press the **Trace** (5) key. Press the Trace A Operations submenu key.
82. Press the # of Averages submenu key, use the keypad to enter 5, and then press the **Enter** key.
83. Wait until the Trace Count displays 5/5.
84. Press the **Marker** main menu key and press the Peak Search submenu key.
85. Record the Marker 1 amplitude reading into the “Measured Spur Level” column of [Table A-7](#).
86. Calculate the input related spurious level by subtracting the Marker 1 reading in Step 77 from the Marker 1 reading in Step 85. Record the result into the “Calculated IRS” column of [Table A-7](#).
87. Verify that the calculated result is ≤ -60 dBc.

2-5 Resolution Bandwidth Accuracy Verification

The following test is used to verify the resolution bandwidth accuracy of the spectrum analyzer in the MS272xC Spectrum Master.

Equipment Required for MS2722C, MS2723C and MS2724C

- Anritsu MG3692X Synthesized Signal Source
- Frequency Reference Symmetricom Rubisource T&M
- Anritsu 34RKNF50 50 ohm Adapter
- Anritsu 15NN50-1.5C RF Coaxial Cable
- BNC male to BNC male Coaxial Cable

Equipment Required for MS2725C and MS2726C

- Anritsu MG3695C with option 2,3,4,15,22 Synthesized Signal Source
- Frequency Reference Symmetricom Rubisource T&M
- Anritsu 34VKF50 50 ohm Adapter
- Anritsu 3670K50-2 RF Coaxial Cable
- BNC male to BNC male Coaxial Cable

Setup

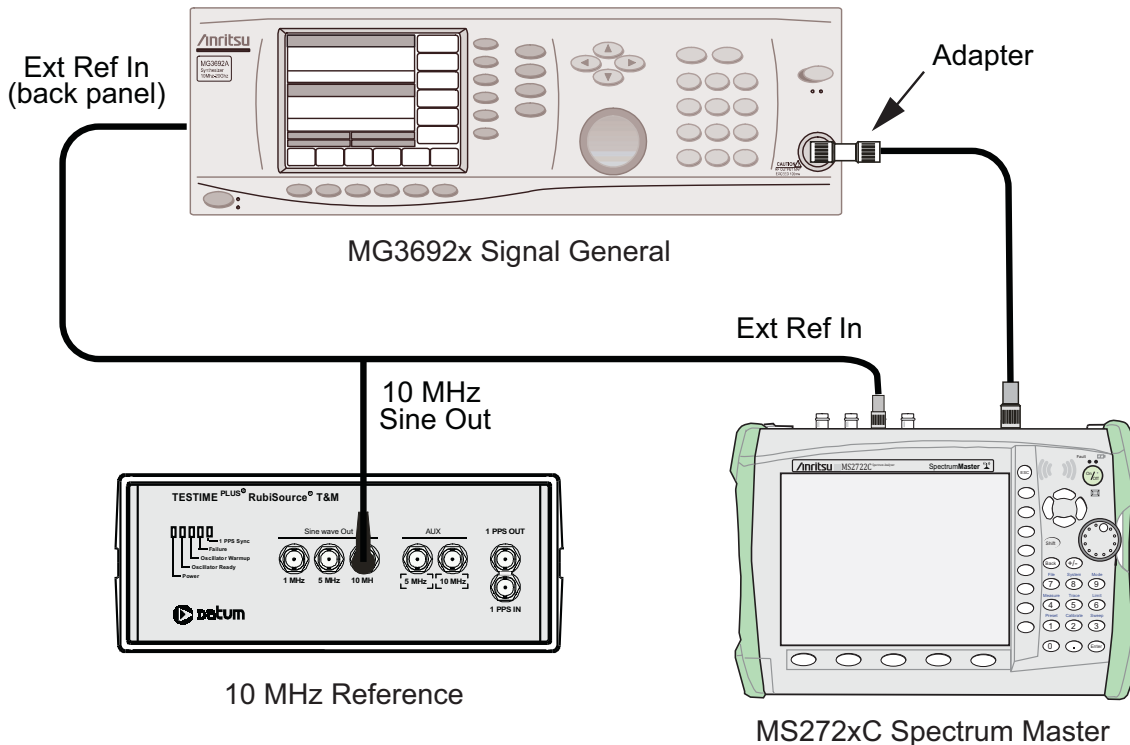

Figure 2-1. Resolution Bandwidth Accuracy Test Setup

Procedure

1. Connect the external 10 MHz Reference both to the MG3692x or MG3695C Synthesized Signal Generator and to the Spectrum Master MS272xC, as shown in [Figure 2-1](#).
2. Set the MS272xC to Spectrum Analyzer mode and then Preset the instrument. Press the **Shift** key, the **Sweep** (3) key, **Sweep Mode** submenu key and then the **Performance** submenu key.
3. Set the MS272xC as follows:
 - Center Frequency: 1.0 GHz
 - Reference Level: -10 dBm
 - Atten Lvl: 0 dB
4. Set the MG3692x or MG3695C to 1 GHz CW, with an output level of -30 dBm. Apply the signal to the Spectrum Analyzer RF In connector of the MS272xC.
5. On the MS272xC, set the Span to 20 MHz.
6. Press the **BW** main menu key and set the RBW to 10 MHz.
7. Press the **VBW** submenu key set to 1 MHz.
8. Under the Press the Shift **Measure** menu (**Shift** (4), press **OCC BW** and set it to On.
9. Press the **dBc** submenu key and enter 3.
10. Record the occupied bandwidth in [Table A-8](#), “[Spectrum Analyzer Resolution Bandwidth Accuracy](#)” on [page A-4](#) and verify that it is within specification.
11. Repeat Step 5 through Step 10 for all other settings in [Table A-8](#) and record the occupied bandwidth in [Table A-8](#).

2-6 Spectrum Analyzer Absolute Amplitude Accuracy Verification

The tests in the following two sections verify the absolute amplitude accuracy of the Spectrum Analyzer in the MS272xC Spectrum Master. The two parts of this test are “50 MHz Amplitude Accuracy Verification” immediately below and “Amplitude Accuracy Across Frequency Verification” on page 2-15.

50 MHz Amplitude Accuracy Verification

Equipment Required for MS2722C, MS2723C and MS2724C

- Anritsu MG3692x Synthesized Signal Generator
- Frequency Reference Symmetricom Rubisource T&M
- Power Meter, Anritsu Model ML2438A
- (2) Power Sensor, Anritsu Model SC7400
- Power Splitter, Aeroflex/Weinschel Model 1870A
- Fixed Attenuator, Aeroflex/Weinschel Model 4410
- (2) Adapter, Anritsu Model 34NN50A
- Coaxial Cable, BNC(m) to BNC(m), 50 ohm
- RF Coaxial Cable, N(m) to N(f), Anritsu Model 15NNF50-1.5C

Setup

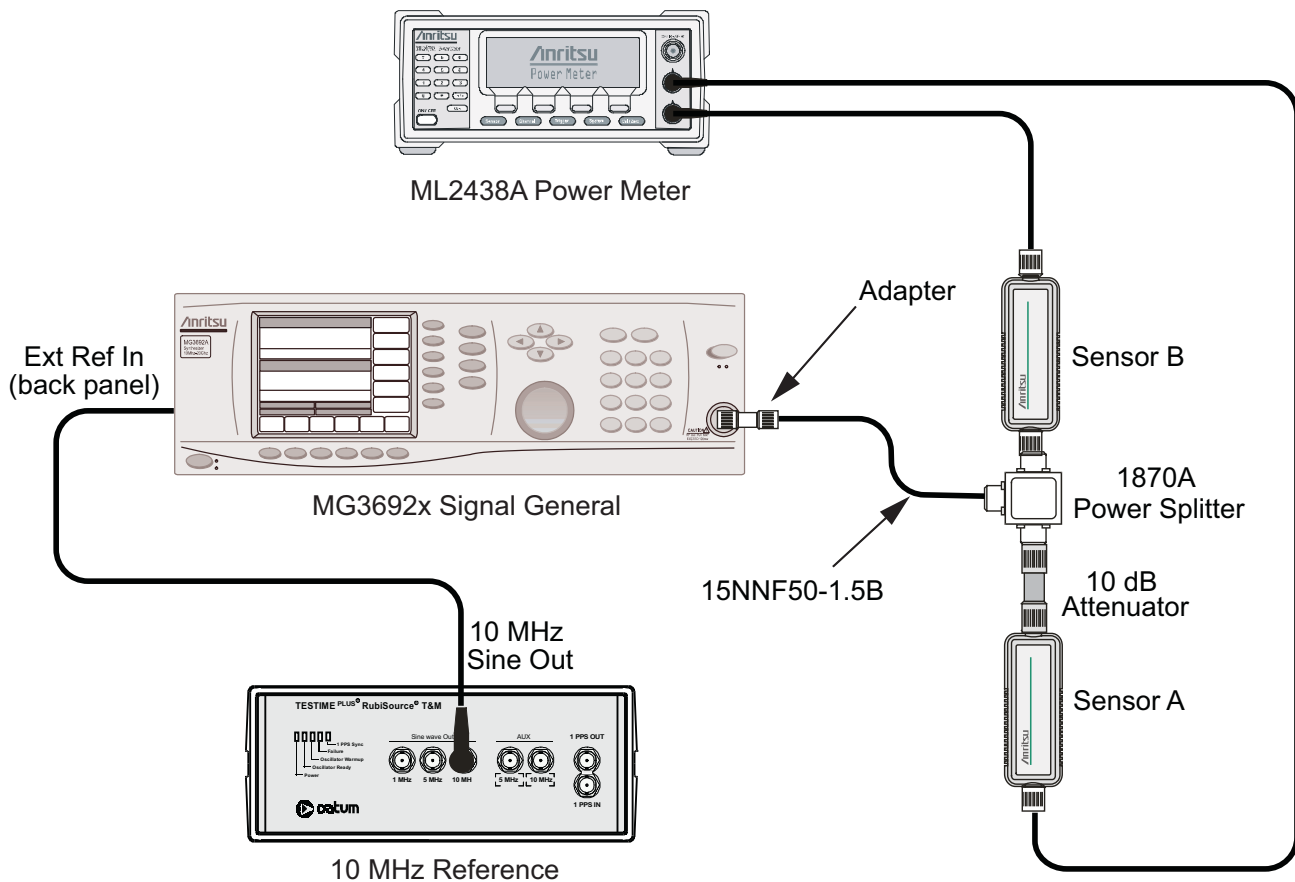

Figure 2-2. 50 MHz Amplitude Accuracy Verification for Models with N Connectors

Equipment Required for MS2725C and MS2726C

- Anritsu MG3695C with option 2,3,4,15,22 Synthesized Signal Source
- Frequency Reference Symmetricom RubiSource T&M
- Anritsu 34VKF50 50 ohm Adapter
- Anritsu 3670K50-2 K RF
- Coaxial cable, BNC(m) to BNC(m), 50 ohm
- Power Meter, Anritsu Model ML2438A
- (2) Power Sensor, Anritsu Model SC7413
- Power Splitter Anritsu Model K241C
- Fixed Attenuator, Anritsu Model 41KC-10

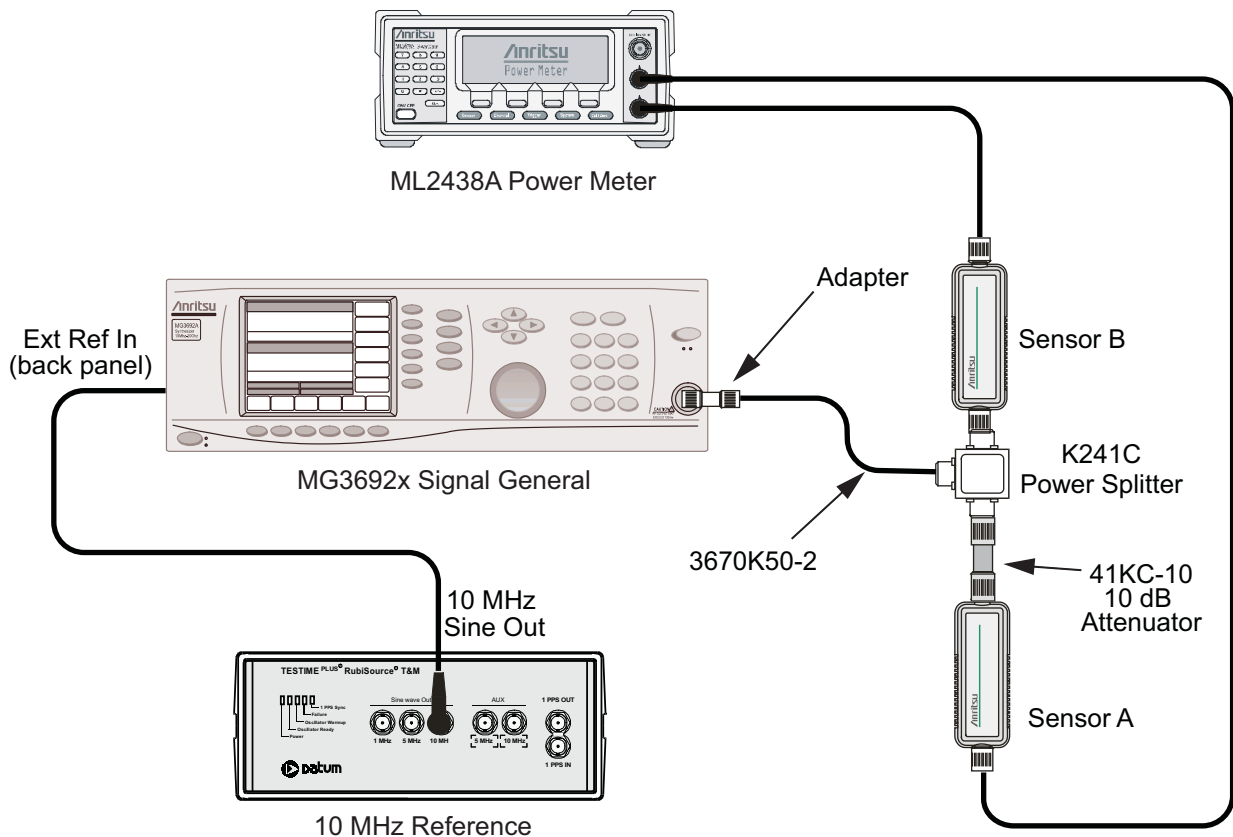

Figure 2-3. 50 MHz Amplitude Accuracy Verification for Models with K Connectors

Component Characterization

1. Connect both power sensors to the power meter, and then zero the sensors.
2. Connect the 10 MHz Reference source to the 10 MHz Ref In connector of the MG3692x or MG3695C Synthesized Signal Generator.
3. Connect the Model 1870A or K241C power splitter to the MG3692x or MG3695C output via the 34NN50A or 34VKF50 adapter, and connect Sensor B to one of the power splitter output connections (refer to [Figure 2-3](#)).
4. Install the 10 dB Fixed Attenuator to the other power splitter output, and then connect Sensor A to the end of the Attenuator.
5. Set the frequency of the MG3692x or MG3695C to 50 MHz.

6. Set the power meter to display both Channel A and Channel B. Press the **Sensor** key, the Cal Factor submenu key, and then the Freq submenu key. Use the keypad to enter the value matching the frequency of MG3692x or MG3695C as the input signal frequency, which sets the power meter to the proper power sensor calibration factor. Repeat for Channel B. Press the **System** key to display the power reading.
7. Adjust the power level of the MG3692x or MG3695C to get a reading on Sensor A that matches the test power level in the first column of [Table A-9, “Characterization Chart for 50 MHz Amplitude Accuracy Verification”](#) on page A-5.
8. Record the Sensor B reading in the “Required Sensor B Reading” column of [Table A-9](#).
9. Repeat Step 7 and Step 8 for the other power levels in the first column of [Table A-9](#), and record the Sensor B readings in the second column.

Note

Before continuing, allow a 30 minute warm up period for the internal circuitry to stabilize.

The listed Amplitude Accuracy specifications in Appendix A apply when the instrument is being verified in an environment between 20°C and 30°C after a 30 minute warm-up period. For an instrument that is not being verified in a temperature controlled environment but within a temperature range between -10°C and 50°C (-10°C and 40°C for MS2726C only) and after a 60 minute warm-up, add ± 1 dB to the Amplitude Accuracy specification for frequencies from 100 kHz to 32 GHz, add ± 2 dB to the Amplitude Accuracy specification for frequencies from 32 GHz to 40 GHz.

Measuring the Unit for 50 MHz Amplitude Accuracy

1. Connect the equipment as shown in [Figure 2-4](#), disconnecting Sensor A from the Attenuator, and connecting the RF In port of the MS272xC to the splitter output via the Attenuator.

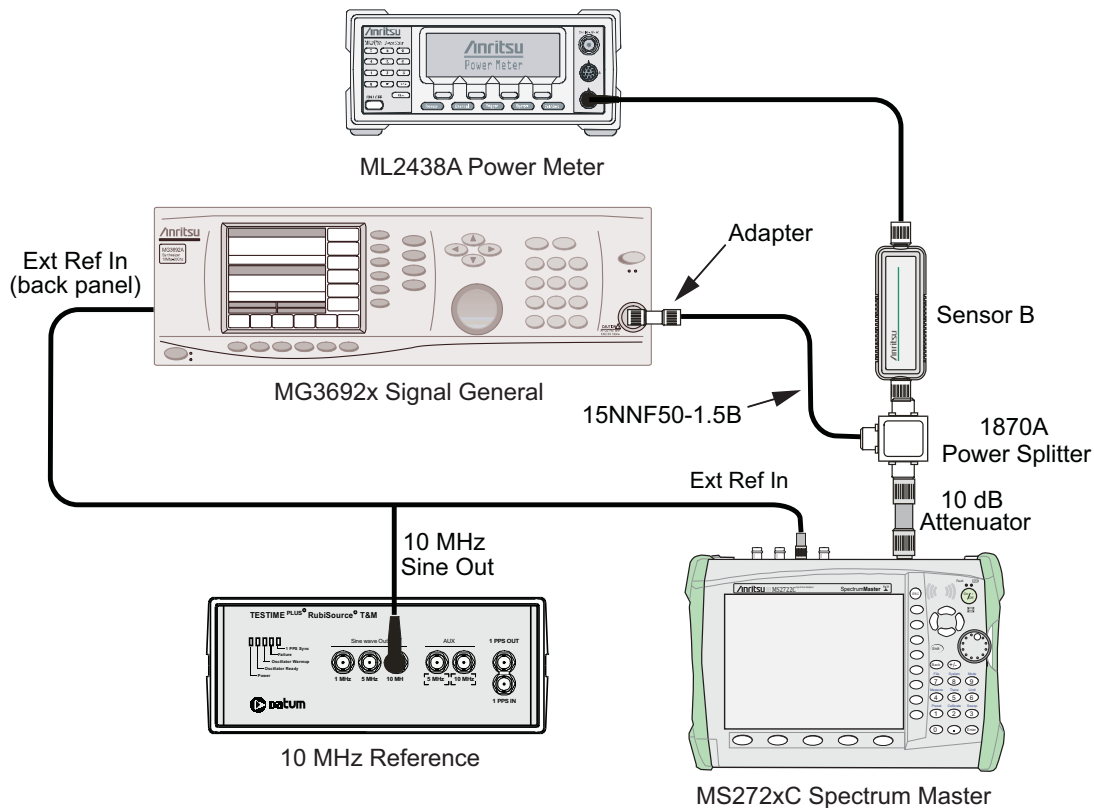
**Figure 2-4.** 50 MHz Amplitude Accuracy Verification, Test Setup

Note To maintain test setup integrity, do not disconnect Sensor B, the power splitter, or the fixed attenuator.

2. Set the MS272xC to Spectrum Analyzer mode and then Preset the instrument. Press the **Shift** key, the **Sweep** (3) key, Sweep Mode submenu key and then the Performance submenu key.
3. Set the MS272xC center frequency to 50 MHz.
4. Set the span to 10 kHz.
5. Press the **BW** main menu key and set the VBW to 10 Hz.
6. Set the RBW to 1 kHz.
7. Press the **Amplitude** main menu key and set the Reference Level to 10 dBm.
8. Set the Atten Lvl to 30 dB.
9. Adjust the MG3692x or MG3695C power level so that the power meter Sensor B matches the Sensor B value (Required Sensor B Reading) that is shown on the characterization chart (Table A-9) that was used in the previous section, “Component Characterization” on page 2-13.
10. Press the **Marker** main menu key and press the Peak Search submenu key.
11. Record the Marker 1 amplitude reading into the “Measured Reading” column of Table A-10, “50 MHz Amplitude Accuracy Verification, Specification = ± 1.3 dBm” on page A-5.
12. Repeat Step 9 to Step 11 for each Input Power Level in Table A-10, change the “Reference Level” and “Atten Lvl” settings as required. for the other power levels in Table A-10.

Amplitude Accuracy Across Frequency Verification

This procedure is the second test used to verify the absolute amplitude accuracy of the Spectrum Analyzer in the MS272xC Spectrum Master. The first procedure test is described above in “50 MHz Amplitude Accuracy Verification” on page 2-12.

Equipment Required for MS2722C, MS2723C and MS2724C

- Anritsu MG3692x Synthesized Signal Generator
- Frequency Reference Symmetricom Rubisource T&M
- Power Meter, Anritsu Model ML2438A
- (2) Power Sensor, Anritsu Model SC7400
- Power Splitter, Aeroflex/Weinschel Model 1870A
- Fixed Attenuator, Aeroflex/Weinschel Model 4410
- (2) Adapter, Anritsu Model 34NN50A
- Coaxial Cable, BNC(m) to BNC(m), 50 ohm
- RF Coaxial Cable, N(m) to N(f), Anritsu Model 15NNF50-1.5C

Equipment Required for MS2725C and MS2726C

- Anritsu MG3695C with option 2,3,4,15,22 Synthesized Signal Source
- Frequency Reference Symmetricom Rubisource T&M
- Anritsu 34VKF50 50 ohm Adapter
- Anritsu 3670K50-2 K RF Coaxial Cable
- BNC male to BNC male Coaxial Cable
- Power Meter, Anritsu Model ML2438A
- (2) Power Sensor, Anritsu Model SC7413
- Power Splitter Anritsu Model K241C
- Fixed Attenuator, Anritsu Model 41KC-10

Component Characterization

1. Connect both of the power sensors to the power meter and zero the sensors.
2. Connect the equipment as shown in [Figure 2-2 on page 2-12](#).
3. Set the MG3692x Frequency to 10.1 MHz.
4. Set the power meter to display both Channel A and Channel B. Press the **Sensor** key, the Cal Factor submenu key, and then the Freq submenu key. Use the keypad to enter the value matching the frequency of MG3692x or MG3695C as the input signal frequency, which sets the power meter to the proper power sensor calibration factor. Repeat for Channel B. Press the **System** key to display the power reading.
5. Adjust the MG3692x or MG3695C output level so that the Sensor A reading is $-2 \text{ dBm} \pm 0.1 \text{ dB}$ or $-5 \text{ dBm} \pm 0.1 \text{ dB}$.
6. Record the Sensor B reading into the “ -2 dBm ” or “ -5 dBm ” column in [Table A-11, “Characterization Chart for Fixed Level with Varying Frequency” on page A-6](#).
7. Adjust the MG3692x or MG3695C output level so that the Sensor A reading is $-30 \text{ dBm} \pm 0.1 \text{ dB}$.
8. Record the Sensor B reading into the “ -30 dBm ” column in [Table A-11](#).
9. Repeat Step 3 through Step 8 for all of the frequencies that are listed in [Table A-11](#) that are pertinent to the model you are verifying as indicated below.
 - Up through 8999.995 MHz for MS2722C
 - Up through 12999.995 MHz for MS2723C
 - Up through 19999.995 MHz for MS2724C
 - Up through 31999.995 MHz for MS2725C
 - Up through 40000 MHz for MS2726C

Note

Before continuing, allow a 30 minute warm up for the internal circuitry to stabilize.

The listed Amplitude Accuracy specifications in Appendix A apply when the instrument is being verified in an environment between 20°C and 30°C after a 30 minute warm-up period. For an instrument that is not being verified in a temperature controlled environment but within a temperature range between -10°C and 50°C (-10°C and 40°C for MS2726C only) and after a 60 minute warm-up, add $\pm 1 \text{ dB}$ to the Amplitude Accuracy specification for frequencies from 100 kHz to 32 GHz, add $\pm 2 \text{ dB}$ to the Amplitude Accuracy specification for frequencies from 32 GHz to 40 GHz.

Measuring Amplitude Accuracy Across Frequency

Procedure

1. Connect the equipment as shown in [Figure 2-2 on page 2-12](#).

Note

To maintain test setup integrity, Do Not Disconnect Sensor B, the power splitter, or the fixed attenuator.

2. Set the MS272xC to Spectrum Analyzer mode and then preset the Spectrum Master. Press the **Shift** key, the **Sweep** (3) key, Sweep Mode submenu key and then the Performance submenu key.
3. Press the **BW** main menu key. Then set the RBW to 1 kHz, and set the VBW to 10 Hz.
4. Press the **Span** main menu key, set the span to 10 kHz.
5. Set the MG3692x or MG3695C frequency to 10.1 MHz CW.
6. Set the MG3692x or MG3695C output to -20 dBm .

7. Set the power meter to display Channel B. Press the **Sensor** key, the Cal Factor submenu key, and then the **Freq** submenu key. Use the keypad to enter the value matching the frequency of MG3692x or MG3695C as the input signal frequency, which sets the power meter to the proper power sensor calibration factor. Press the **System** key to display the power reading.
8. Adjust the MG3692x or MG3695C output power so that the power meter displays a reading that matches the Sensor B reading for -30 dBm in [Table A-11](#).
9. On the MS272xC, press the **Amplitude** main menu key, then set the Reference Level to -20 dBm.
10. Press the **Freq** main menu key and press the Center Freq submenu key.
11. Enter 10.1 MHz (or the next frequency).
12. Press the **Amplitude** main menu key, then set the Atten Lvl to 0 dB.
13. Press the **Marker** main menu key and press the Peak Search submenu key.
14. Record the Marker 1 amplitude reading (in units of dBm) into [Table A-12](#).
15. Verify that the Marker 1 amplitude reading is within the specification.
16. Repeat Step 12 through Step 14 for Attenuation Levels of 5 dB, 10 dB, and 20 dB.
17. Adjust the MG3692x or MG3695C output power so that the power meter displays a reading that matches the Sensor B reading for -2 dBm or -5 dBm in [Table A-11](#).
18. On the MS272xC, press the **Amplitude** main menu key, then set the Reference Level to 10 dBm.
19. Repeat Step 12 through Step 14 for Attenuation Levels of 30 dB, 40 dB, 50 dB, and 60 dB.
20. Repeat Step 5 through Step 19. Set the MG3692x or MG3695C frequency to each of the frequencies in [Table A-13](#), “Verification at 100 MHz, Specification = ± 1.3 dB” on page A-8 through [Table A-58](#), “Verification at 40.0 GHz, Specification = ± 2.3 dB” on page A-31.
21. Stop at the applicable frequency for the model under test as listed below:
 - 8.999995 GHz for MS2722C ([Table A-23](#))
 - 12.999995 GHz for MS2723C ([Table A-28](#))
 - 19.999995 GHz for MS2724C ([Table A-36](#))
 - 31.999995 GHz for MS2725C ([Table A-49](#))
 - 40 GHz for MS2726C ([Table A-58](#))

2-7 Residual Spurious Response Verification

The following two tests are used to verify the residual spurious response of the Spectrum Analyzer of the MS272xC Spectrum Master and is performed using the positive peak detection mode. The two parts to this test are the “[Residual Spurious Response Test with Preamp Off](#)” immediately below and the “[Residual Spurious Response Test with Preamp On](#)” on page 2-19.

Residual Spurious Response Test with Preamp Off

Equipment Required for MS2722C, MS2723C and MS2724C

- Anritsu 28N50-2 50 ohm Termination

Equipment Required for MS2725C and MS2726C

- Anritsu 28KF50 50 ohm Termination

Procedure

1. Connect the 50 ohm termination to the Spectrum Analyzer RF In connector.
2. Set the MS27xC to Spectrum Analyzer mode and then Preset the instrument. Press the **Shift** key, the **Sweep** (3) key, Sweep Mode submenu key and then the Performance submenu key.
3. Press the **Amplitude** key, then press the Reference Level submenu key.
4. Use the keypad to enter -40 and press the dBm submenu key.
5. Press the Atten Lvl submenu key and enter 0, then press the dB submenu key.
6. Confirm that the Pre Amp On/Off submenu key is in the Off position. If the preamp is On, then press the Pre Amp On/Off submenu key to turn it Off.
7. Press the Detection submenu key and then the Peak submenu key.
8. Press the **Freq** main menu key and press the Start Freq submenu key.
9. Use the keypad to enter 9, and press the kHz submenu key.
10. Press the Stop Freq submenu key, enter 100, and press the kHz submenu key.
11. Press the **BW** main menu key and press the RBW submenu key.
12. Use the keypad to enter 300, and press the Hz submenu key.
13. Press the VBW submenu key and use the keypad to enter 10, then press the Hz submenu key.
14. Wait until one sweep is completed.
15. Press the **Marker** main menu key and press the Peak Search submenu key.
16. Record the Marker 1 amplitude reading and verify that it is ≤ -90 dBm in [Table A-59](#), “[Spectrum Analyzer Residual Spurious \(Preamp Off\)](#)” on page A-32.

Note

If a spur with an amplitude larger than -90 dBm occurs, wait another full sweep and observe whether the spur occurs at the same point on the second sweep. If the spur does not occur at the same point on the second sweep, then the spur on the first sweep was not real.

17. Repeat Step 8 through Step 16 for the other Start and Stop frequencies with the RBW and VBW as listed in [Table A-59](#) and verify that the readings are within the listed specifications. Note to stop at the applicable frequency limit of the model under test as listed below:
 - 9 GHz for MS2722C
 - 13 GHz for MS2723C
 - 20 GHz for MS2724C
 - 32 GHz for MS2725C
 - 43 GHz for MS2726C

Residual Spurious Response Test with Preamp On

Equipment Required for MS2722C, MS2723C and MS2724C

- Anritsu 28N50-2 50 ohm Termination

Equipment Required for MS2725C and MS2726C

- Anritsu 28KF50 50 ohm Termination

Procedure

1. Connect the 50 ohm termination to the Spectrum Analyzer RF In connector.
2. Set the MS272xC to Spectrum Analyzer mode and then Preset the instrument. Press the **Shift** key, the **Sweep** (3) key, Sweep Mode submenu key and then the Performance submenu key.
3. Press the **Amplitude** key, then press the Reference Level submenu key.
4. Use the keypad to enter -50 and press the dBm submenu key.
5. Press the Atten Lvl submenu key and enter 0, then press the dB submenu key.
6. Ensure that the Pre Amp On/Off submenu key is in the On position. If the preamp is Off, then press the Pre Amp On/Off submenu key to turn it On.
7. Press the **Shift** key and then press the **Sweep** (3) key, then press Detection and then the Peak submenu key.
8. Press the **BW** main menu key and press the RBW submenu key.
9. Use the keypad to enter 300, and press the Hz submenu key.
10. Press the VBW submenu key and use the keypad to enter 10, then press the Hz submenu key.
11. Press the **Freq** main menu key, and press the Start Freq submenu key.
12. Use the keypad to enter 9, and press the kHz submenu key.
13. Press the Stop Freq submenu key, enter 100, and press the kHz submenu key.
14. Wait until one sweep is completed.
15. Press the **Marker** main menu key, and press the Peak Search submenu key.
16. Verify that the Marker 1 amplitude reading is ≤ -100 dBm and record it in [Table A-60, "Spectrum Analyzer Residual Spurious \(Preamp On\)"](#) on page A-33.

Note

If a spur with an amplitude larger than -100 dBm occurs, wait another full sweep and observe whether the spur occurs at the same point on the second sweep. If the spur does not occur at the same point on the second sweep, then the spur on the first sweep was not real.

17. Repeat Step 8 through Step 16 for the other Start and Stop frequencies with the RBW and VBW as listed in [Table A-60](#). Note to stop at the applicable frequency limit of the model under test as listed below:
 - 9 GHz for MS2722C
 - 13 GHz for MS2723C
 - 20 GHz for MS2724C
 - 32 GHz for MS2725C
 - 43 GHz for MS2726C

2-8 Displayed Average Noise Level (DANL)

The following test is used to verify the Displayed Average Noise Level (DANL) of the spectrum analyzer systems in the MS272xC Spectrum Master.

Equipment Required for MS2722C, MS2723C and MS2724C

- Anritsu 28N50-2 50 ohm Termination

Equipment Required for MS2725C and MS2726C

- Anritsu 28KF50 50 ohm Termination

Preamp On Procedure

1. Connect the 28N50-2 or 28KF50-2 50 ohm termination to the MS272xC Spectrum Analyzer RF In.
2. Set the MS272xC to Spectrum Analyzer mode and then preset the instrument. Press the **Shift** key, the **Sweep** (3) key, Sweep Mode submenu key and then the Performance submenu key.
3. Press the **Amplitude** main menu key and set Atten Lvl to 0 dB and Reference Level to -50 dBm.
4. Press the Pre Amp On/Off submenu key to turn it On.
5. Press the Detection submenu key, then press RMS/Avg (red dot appears on the RMS/Avg label).
6. Press the **BW** main menu key and select RBW of 100 kHz. Press the VBW submenu key and select VBW of 1 kHz. Toggle the VBW/Average Type submenu key and ensure Log is selected.
7. Press the Freq submenu key and enter into the MS272xC the Start and Stop frequencies from [Table A-61](#), “Spectrum Analyzer DANL (Preamp On)” on page A-34.
8. Wait until one sweep has been completed.
9. Press the **Marker** main menu key, and press Peak Search.
10. Record the marker reading in the “Measured dBm (100 kHz RBW)” column in [Table A-61](#).
11. Repeat Step 7 through Step 10 for the preamp On measurements, using the Start and Stop frequencies listed in [Table A-61](#).
12. For each measured 100 kHz value in [Table A-61](#), convert the value to 1 Hz RBW value by subtracting 50 dB. (For example, if the marker shows a value of -110 dBm at 100 kHz RBW, then the calculated value at 1 Hz RBW is -160 dBm.) Enter the calculated values in [Table A-61](#). Example equation:

$$(-110 \text{ dBm}) - (50 \text{ dB}) = -160 \text{ dBm}$$

Preamp Off Procedure

13. Press the **Amplitude** main menu key.
14. Set Reference Level to -20 dBm, and ensure the preamp is set to Off.
15. Repeat Step 7 through Step 12 for the preamp Off measurements, using Start and Stop frequencies listed in [Table A-62](#), “Spectrum Analyzer DANL (Preamp Off)” on page A-34.
16. Enter the Measured dBm and calculated 1 Hz RBW values in [Table A-62](#).
17. Stop at the applicable frequency limit of the model under test as listed below:
 - 9 GHz for MS2722C
 - 13 GHz for MS2723C
 - 20 GHz for MS2724C
 - 32 GHz for MS2725C
 - 43 GHz for MS2726C

2-9 Third Order Intercept (TOI)

The following test is used to verify the Displayed Average Noise Level (DANL) of the spectrum analyzer systems in the MS272xC Spectrum Master. This test is performed using the RMS detection mode.

The following test verifies the Third Order Intercept point (also known as TOI or IP₃) of the spectrum analyzer in Spectrum Master Models MS2722C, MS2723C, MS2724C, MS2725C and MS2726C.

2400 MHz TOI Test

Equipment Required for MS2722C, MS2723C and MS2724C

- Anritsu MG3692x Synthesized Signal Generator
- Frequency Reference Symmetricom Rubisource T&M
- Adapter, Anritsu Model 34NN50A
- Spectrum Master: MS272xC
- Power Meter, Anritsu Model ML2438A
- Signal Generator, Agilent Model 8648D
- Power Splitter, Aeroflex/Weinschel Model 1870A
- Power Sensor, Anritsu Model MA2442D (10 MHz to 18 GHz, -67 dB to +20 dB)
- Fixed Attenuator, Aeroflex/Weinschel Model 442
- Fixed Attenuator, Aeroflex/Weinschel Model 446
- Fixed Attenuator, Aeroflex/Weinschel Model 4420
- RF Coaxial Cable, N(m) to N(f), Anritsu Model 15NNF50-1.5C (3)

Equipment Required for MS2725C and MS2726C

- All of the above
- Anritsu 71693-R Ruggedized K(f) to N(f) Adapter

Setup

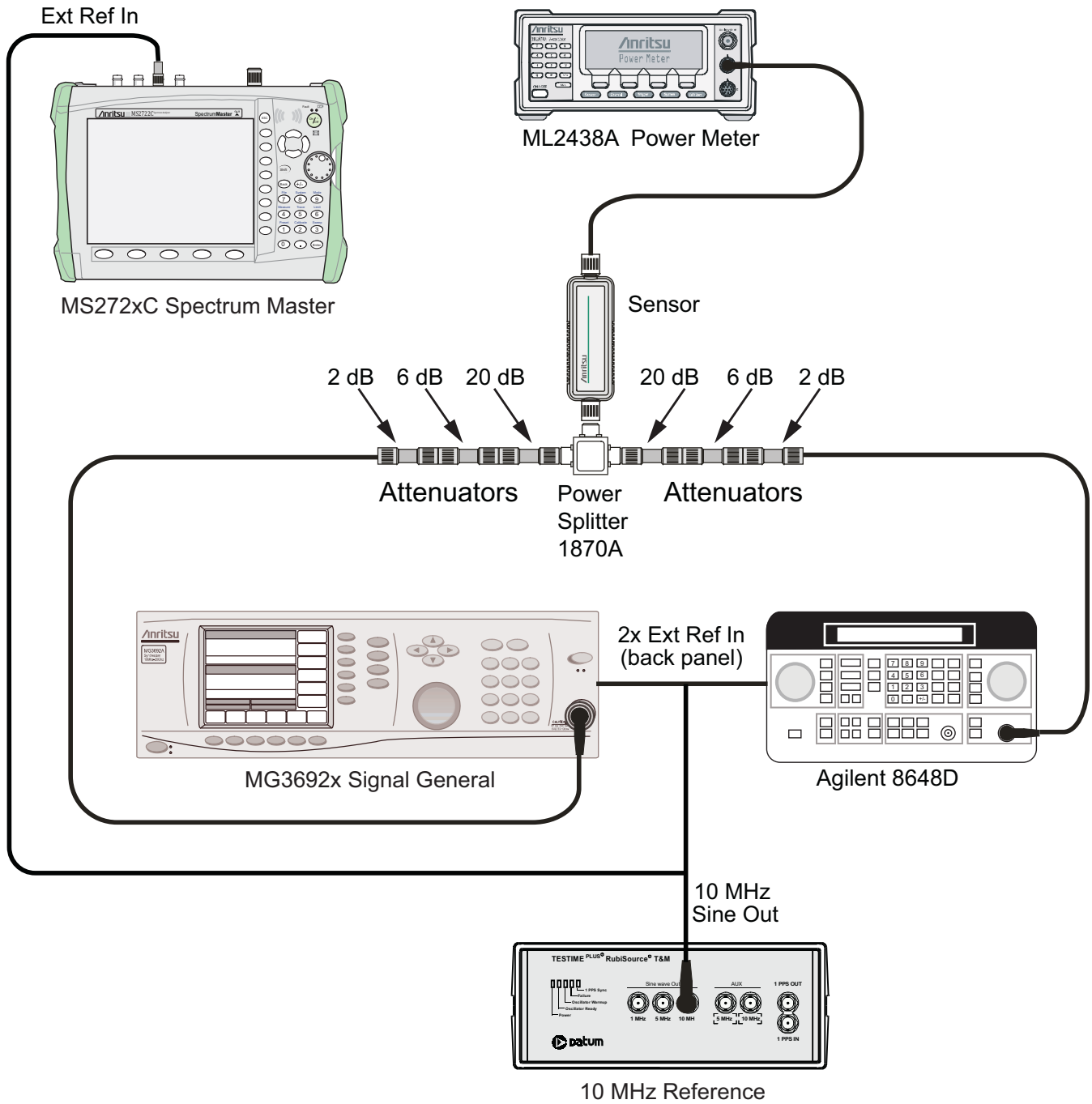

Figure 2-5. 2400 MHz TOI Verification Characterization, Component Characterization Setup

Procedure

1. Connect the equipment as shown in [Figure 2-5](#). The splitter will be used as an RF combiner (the normal RF outputs will become inputs, and the normal input will become the RF output).
2. Set the MG3692x Synthesized Signal Generator to 2399.951 MHz CW, and set the Agilent 8648D Signal Generator to 2400.051 MHz.
3. Set the Agilent 8648D Signal Generator RF to OFF (“RF OFF” appears on the right side of the display).
4. On the ML2438A power meter, zero the sensor and set the calibration factor to 2.4 GHz.
5. Connect the power sensor to the splitter output and adjust the power of the MG3692x so that –20 dBm appears at the splitter output (approximately +16 dBm).
6. Turn Off the RF of the MG3692x Synthesized Signal Generator.
7. On the Agilent 8648D Signal Generator, turn the RF On, and adjust the RF amplitude so that –20 dBm appears at the splitter output (approximately +16 dBm).
8. Set the MS272xC to Spectrum Analyzer mode and then Preset the instrument. Press the **Shift** key, the **Sweep** (3) key, Sweep Mode submenu key and then the Performance submenu key.
9. Set the MS272xC as follows:
 - Center Frequency: 2400.151 MHz
 - Span: 100 Hz
 - RBW: 30 Hz
 - VBW: 1 Hz
 - Reference Level: –15 dBm
 - Atten Lvl: 0 dB
 - Preamp: Off
10. Press the **Shift** key and the **Sweep** (3) key. Press Detection, and press RMS (red dot appears on the label).
11. Disconnect the power sensor from the output of the splitter and connect the splitter output to the MS272xC Spectrum Analyzer RF In connector through the Anritsu Model 34NN50A or 71693-R adapter ([Figure 2-6 on page 2-24](#)).
12. Turn On the RF of the MG3692x and the 8648D.
13. Press the **Shift** key and then the **Trace** (5) key. Press Trace A Operations, and set # of Averages to 2.
14. After two sweeps have occurred (Trace Count 2/2 appears on the left of the display), turn on a marker, and press Peak Search. Record the amplitude of the signal at 2400.151 MHz in [Table A-63, “Spectrum Analyzer Third Order Intercept” on page A-34](#).
15. Change the Center Frequency of the MS272xC to 2399.851 MHz. Record the amplitude of this signal in [Table A-63](#).
16. Determine which signal is larger (the 2399.851 MHz signal or the 2400.151 MHz signal). Use the larger value for max in the following formula to calculate the TOI for 2400 MHz (refer to the example calculation below the formula):
 - $$\text{TOI} = -20 + [(-20 - \text{max}) / 2] \text{ dBm}$$
 - Example: Assume max = –90 dBm
 - Then: $\text{TOI} = -20 + [(-20 - (-90))/2] = +15 \text{ dBm}$
17. Record the calculated 2400 MHz TOI measurement in [Table A-63](#).

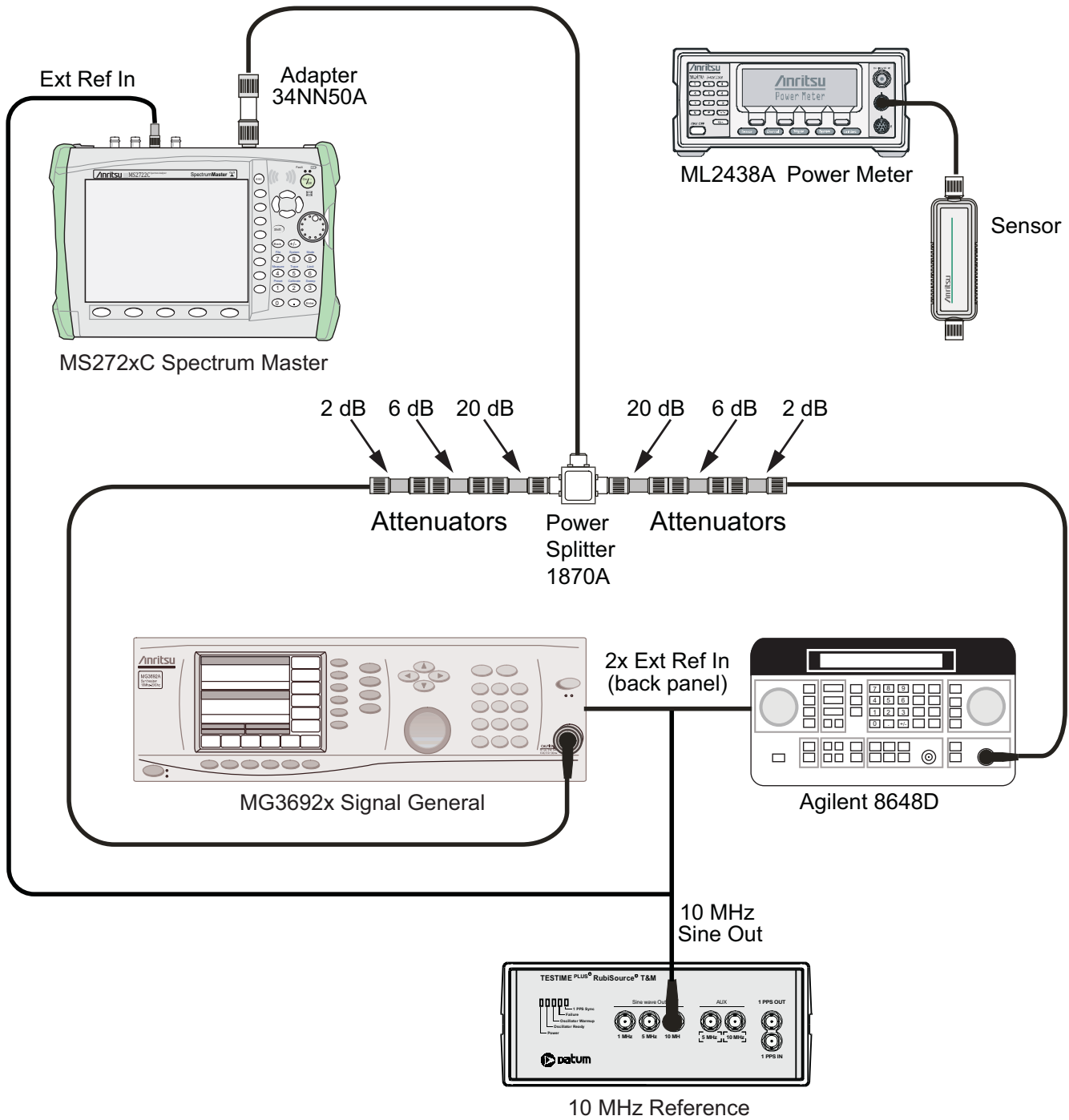

Figure 2-6. 2400 MHz TOI Verification, Test Setup

Chapter 3 — Options Verification

3-1 Introduction

The chapter describes the verification process for options available for the MS272xC Spectrum Master.

3-2 Option 31, GPS Frequency Accuracy Verification

The following test verifies the Spectrum Analyzer Frequency Accuracy with GPS Option 31 in the model MS272xC Spectrum Master.

Equipment Required for MS2722C, MS2723C and MS2724C

- Anritsu MG3692X Synthesized Signal Source
- Frequency Reference Symmetricom Rubisource T&M
- Anritsu 34RKNF50 50 ohm Adapter
- Anritsu 15NN50-1.5C RF Coaxial Cable
- BNC male to BNC male Coaxial Cable
- GPS Antenna, Anritsu 2000-1528-R

Equipment Required for MS2725C and MS2726C

- All of the above
- Anritsu 71693-R Ruggedized K(f) to N(f) Adapter

Setup

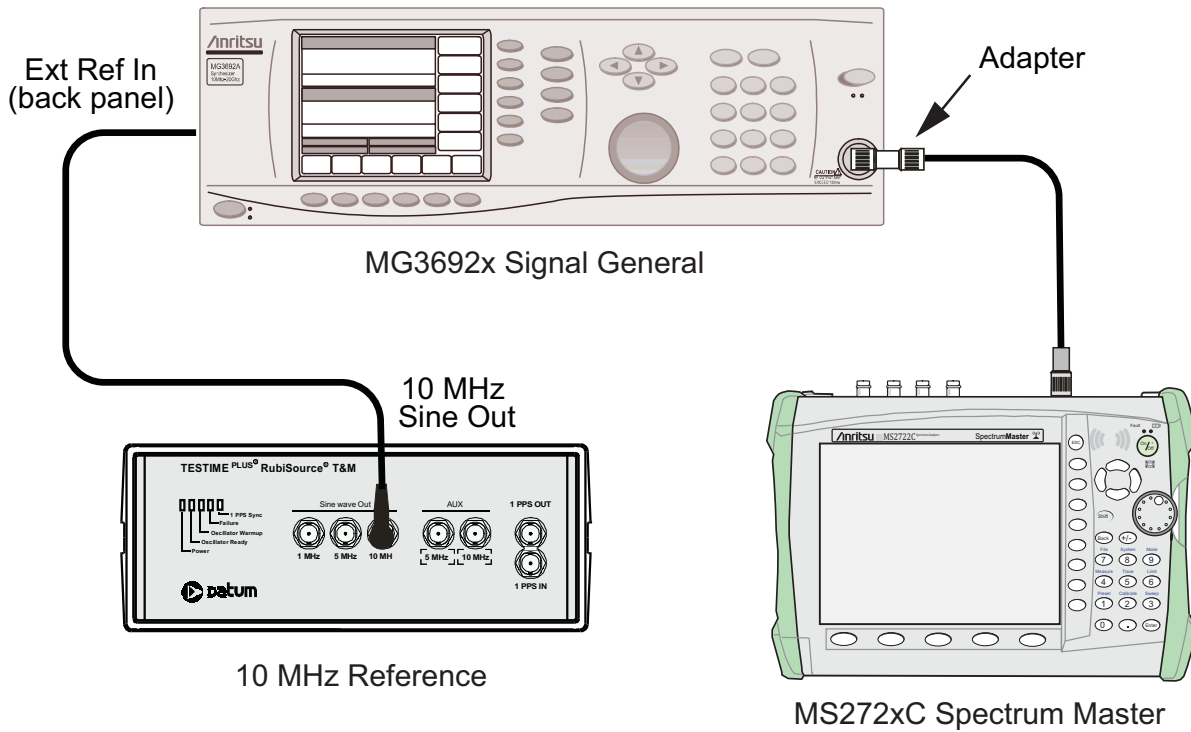

Figure 3-1. Frequency Accuracy Verification by Synthesized Signal Generator

Setup Procedure

1. Connect the GPS antenna to the GPS Antenna connector on the MS272xC.

Note If no fixed GPS antenna is available, the Anritsu 2000-1528-R GPS antenna can be used for this test. Ensure that the Anritsu 2000-1528-R GPS antenna is in a direct line of sight relationship to the satellites or that the antenna is placed outside with no obstructions.

2. Press the **Shift** key and then the **System** (8) key.
3. Press the GPS submenu key, then press the GPS On/Off submenu key to turn the GPS On.
4. When the GPS fix is acquired, the GPS indicator at the top of the LCD display turns green. The latitude and the longitude are displayed next to the GPS indicator.
5. After about three minutes, the Reference Source indicator in the lower left corner of the LCD display will change to *GPS High Accy*.
6. If the GPS fix is acquired using the Anritsu 2000-1528-R GPS antenna outside, then bringing the instrument inside will cause a loss of satellite tracking. A red cross will appear on the green GPS indicator, and the Reference Source indicator will change to *Int Hi Accy*.

Note The following test can be used to verify frequency accuracy to either specification.

Test Procedure

1. Connect the external 10 MHz Reference to the Anritsu MG3692x Synthesized Signal Generator.

Note Do not connect the external 10 MHz Reference to the MS272xC Spectrum Master.
--

2. Connect the output of the Synthesized Signal Generator to the Spectrum Analyzer RF In of the MS272xC, as shown in [Figure 3-1](#).
3. On the MS272xC, change the mode to Spectrum Analyzer and preset the instrument.
4. Set the MG3692x output to 7 GHz CW, with an RF output level of -30 dBm.
5. On the MS272xC, press the **Amplitude** main menu key, and set the Ref Lvl to -10 dBm.
6. Press the **Freq** main menu key and set the Center Freq to 7.0 GHz.
7. Press the **Span** main menu key and set the Span to 10 kHz.
8. Press the **BW** main menu key and set RBW to 100 Hz.
9. Press the VBW submenu key and set VBW to 30 Hz.
10. Press the **Marker** main menu key, then press the Peak Search submenu key.
11. Note the Reference Source display and use the appropriate row to record the data in the following steps.
12. Record the marker frequency into the “Measured Value” column of [Table A-64, “Option 31, GPS Receiver Frequency Accuracy”](#) on [page A-35](#).
13. Subtract the marker value from 7 GHz, record the result into the Error column of [Table A-64](#), and verify that it is within specification.
14. If the value of Reference Source indicates *GPS High Accuracy*, then remove the GPS antenna and wait until the Reference Source indicates *Int Hi Accy* and repeat steps 16 through 19 if necessary.

GPS Option Bias-Tee Voltage Verification (Option 31)

The following test verifies the GPS Antenna Bias-Tee Voltages of Option 31 in the model MS272xC Spectrum Master.

Equipment Required for MS2722C, MS2723C, MS2724C, MS2725C and MS2726C

- Adapter SMA to BNC(f), Pomona 4290 or equivalent
- Adapter GPS Terminator, Amphenol B1004A1-ND3G-93R-0.05-1W or equivalent

Procedure

1. Connect the external power supply (Anritsu PN 40-168-R) to the MS272xC Spectrum Master.
2. Press the **On/Off** key to turn on the MS272xC.
3. Set the MT822xB to Spectrum Analyzer mode and preset the unit.
4. Press the **Shift** key, and then the **System** (3) key.

3.3 V Test

5. Connect the 4290 Adapter to the GPS Antenna SMA connector.
6. Connect the GPS Terminator to the 4290 Adapter.
7. Ensure the 3.3V setting on the GPS Voltage submenu key is selected (underlined)
8. Turn GPS On by toggling the GPS submenu key so that the On text is underlined.
9. Select the GPS Info submenu key. Record the GPS Antenna Current reading in the “Measured Current Value” column of [Table 3-1, “Option 31, GPS Receiver Bias-Tee Verification”](#) on [page 3-4](#) and verify that it is within specification.

5V Test

10. Press the **Escape** key to dismiss the GPS Info dialog box.
11. Press the GPS Voltage submenu key and select 5V.
12. Select the GPS Info submenu key. Record the GPS Antenna Current reading in the “Measured Current Value” column of [Table 3-1](#) and verify that it is within specification.

Table 3-1. Option 31, GPS Receiver Bias-Tee Verification

Voltage	Measured Current Value	Specification
3.3 V	mA	32 mA \pm 15% (27.2 to 36.8 mA)
5.0 V	mA	55.6 mA \pm 15% (47.3 to 63.9 mA)

3-3 Option 40 and/or 41, GSM/GPRS/EDGE Signal Analyzer Verification

The tests in this section verify the optional GSM/GPRS/EDGE Signal Analyzer functions in Model MS272xC Spectrum Master.

Equipment Required for MS2722C, MS2723C and MS2724C

- Anritsu MG3700A Vector Signal Generator
- Frequency Reference Symmetricom Rubisource T&M
- Power Meter, Anritsu Model ML2438A
- Power Sensor, Anritsu Model MA2482D
- Anritsu 34NN50A 50 ohm Adapter (2)
- Anritsu 15NN50-1.5C RF Coaxial Cable
- BNC male to BNC male Coaxial Cable
- Power Splitter, Aeroflex/Weinschel Model 1870A

Equipment Required for MS2725C and MS2726C

- All of the above
- Anritsu 71693-R Ruggedized K(f) to N(f) Adapter

Setup

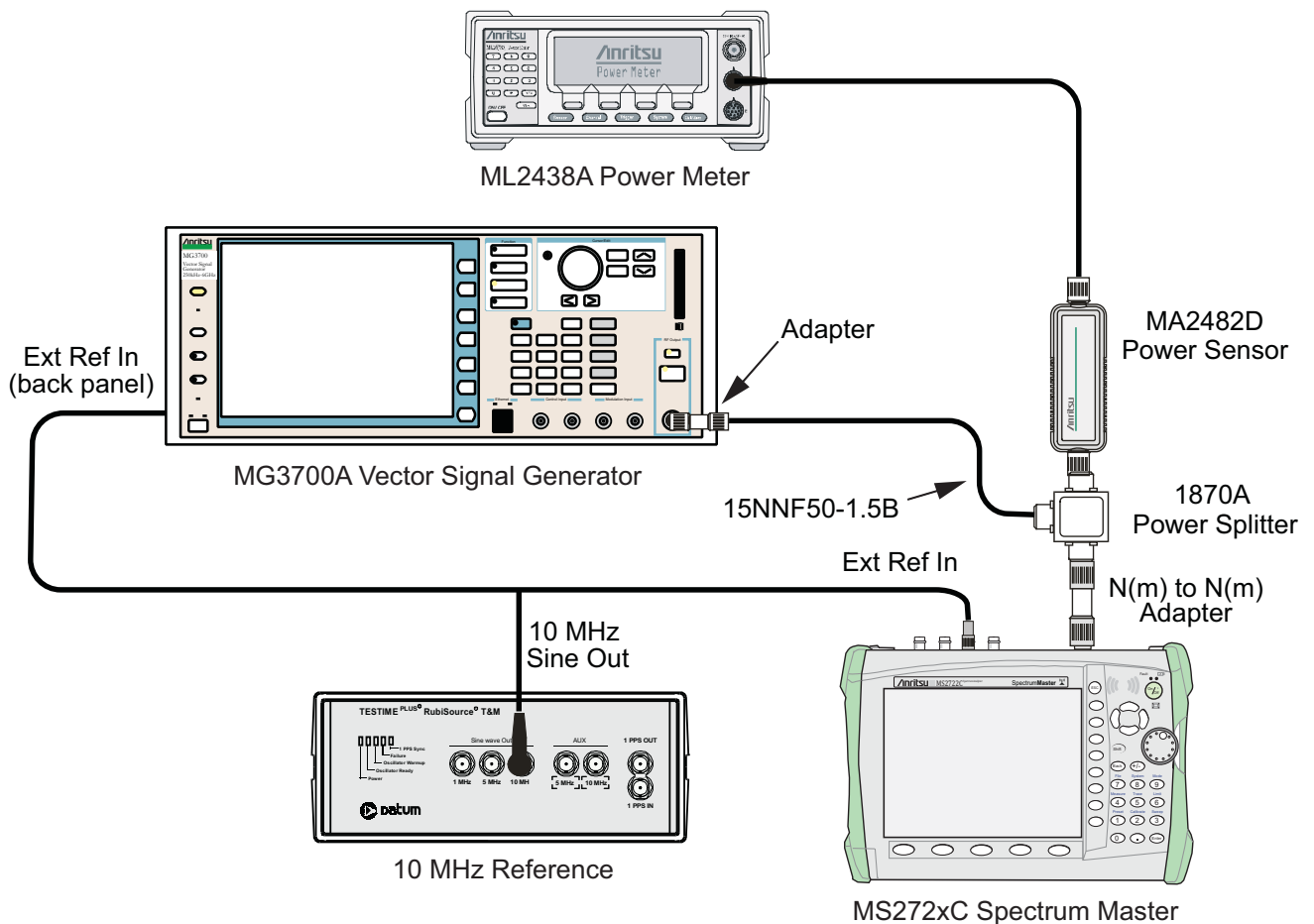

Figure 3-2. GSM/GPRS/EDGE, Test Setup

Set up Procedure

1. Zero the power sensor prior to connecting to the power splitter.
2. Set the Power Meter Measurement MODE to True RMS, set Averaging MODE to Moving, and set Averaging NUMBER to **256**.
3. Connect the equipment as shown in [Figure 3-2](#)
4. On the power meter, press the **Sensor** key, the Cal Factor submenu key, and then the **Freq** submenu key. Use the keypad to enter 850 MHz as the input signal frequency, which sets the power meter to the proper power sensor calibration factor. Press the **System** key to display the power reading.
5. Set the MS272xC mode to GSM/GPRS/EDGE Signal Analyzer. Preset the instrument.

GSM Burst Power, Frequency Error and Phase Error Tests

Test Procedure

1. On the MG3700A, press the **Preset** key (Yellow key on the upper-left corner).
2. Press the **Down Arrow** key, or turn the knob to press **Yes**.
3. Press the **Set** key (Note that two Set keys are available, and they both do the same thing).
4. Press the (F1) submenu key to select “Load File to Memory”.
5. Press the (F1) submenu key again to select “Select Package”.
6. Using the **Down Arrow** key, step through the selection list until the GSM option is highlighted.
7. Press the **Set** key.
8. Press the (F6) submenu key, Return.
9. Press the **Set** key. The Select Package box appears. Use the rotary knob to highlight GSM and press the **Set** key to select.
10. Another File List appears. Use the rotary knob to select GsmBurst_1slot, and press the **Set** key to select.
11. Press the **MOD On/Off** key to turn the Modulation LED On, and verify the Playing indicator in the center of the LCD is flashing.
12. Press the **Frequency** key, and enter 850 MHz.
13. Press the **Level** key, enter -10, and press the **dBm** key.
14. Adjust the MG3700A output so that the power meter reads $-10 \text{ dBm} \pm 0.2 \text{ dB}$. Record the adjusted power reading into the “Adjusted Output Power” row of [Table A-65](#), “[Option 40, At 850 MHz, -10 dBm Level, TCH Pattern \(GSM\)](#)” on page A-35.
15. On the MS272xC, press the **Freq** main menu key and enter 850 MHz as Center Freq.
16. Press the **Measurements** main menu key, and press GSM/EDGE Summary (a red dot is displayed on the label).
17. For MS272xC with Option 40 (GSM/GPRS/EDGE RF Measurements), record the measured value into the “Displayed Burst Power” row of [Table A-65](#), then subtract the “Displayed Burst Power” value from the “Adjusted Output Power” reading that was obtained in Step 14. Then record the “Calculated Burst Power Error” and the displayed value of “Frequency Error” into [Table A-65](#).
18. For MS272xC with Option 41 (GSM/GPRS/EDGE Demodulator), record the displayed Phase Err RMS (deg) into [Table A-73](#), “[Option 41, At 850 MHz, -10 dBm Level, TCH Pattern \(GSM\)](#)” on page A-38.
19. Verify that the measured values in Step 17 and Step 18 are within specifications.
20. On the MG3700A, change the selected signal pattern to GsmBurst_8slot.

21. Adjust the Level of the MG3700A so that the power meter reads $-50 \text{ dBm} \pm 0.2 \text{ dB}$. Record the adjusted power reading into the “Adjusted Output Power” row of [Table A-66](#), “[Option 40, At 850 MHz, \$-50 \text{ dBm}\$ Level, TCH All Pattern \(GSM\)](#)” on page A-35. Then wait 15 seconds to allow the MS272xC to update its measured results.
22. For MS272xC with Option 40 (GSM/GPRS/EDGE RF Measurements), record the measured value into the “Displayed Burst Power” row of [Table A-66](#), then subtract the “Displayed Burst Power” value from the “Adjusted Output Power” reading that was obtained in Step 21. Then record the “Calculated Burst Power Error” and the displayed value of “Frequency Error” into [Table A-66](#).
23. For MS272xC with Option 41 (GSM/GPRS/EDGE Demodulator), record the displayed Phase Err RMS (deg) into [Table A-74](#), “[Option 41, At 850 MHz, \$-50 \text{ dBm}\$ Level, TCH ALL Pattern \(GSM\)](#)” on page A-38.
24. Verify that the measured values in Step 22 and Step 23 are within specifications.
25. Change the frequency of MG3700A to 1800 MHz.
26. On the power meter, press the **Sensor** key, the Cal Factor submenu key, and then the Freq submenu. Use the keypad to enter 1800 MHz as the input signal frequency, which sets the power meter to the proper power sensor calibration factor. Press the **System** key to display the power reading.
27. Adjust the level of the MG3700A so that the power meter reads $-10 \text{ dBm} \pm 0.2 \text{ dB}$. Record the adjusted power reading into the “Adjusted Output Power” row of [Table A-67](#), “[Option 40, At 1800 MHz, \$-10 \text{ dBm}\$ Level, TCH ALL Pattern \(GSM\)](#)” on page A-36.
28. On the MS272xC, set the Center Freq to 1800 MHz. Then wait 15 seconds to allow the MS272xC to update its measured results.
29. For MS272xC with Option 40 (GSM/GPRS/EDGE RF Measurements), record the measured value into the “Displayed Burst Power” row of [Table A-67](#), then subtract the “Displayed Burst Power” value from the “Adjusted Output Power” reading that was obtained in Step 27. Then record the “Calculated Burst Power Error” and the displayed value of “Frequency Error” into [Table A-67](#).
30. For MS272xC with Option 41 (GSM/GPRS/EDGE Demodulator), record the displayed Phase Err RMS (deg) into [Table A-75](#), “[Option 41, At 1800 MHz, \$-10 \text{ dBm}\$ Level, TCH ALL Pattern \(GSM\)](#)” on page A-38.
31. Verify that the measured values in Step 29 or Step 30 or both are within specifications.
32. On the MG3700A, change the selected pattern to `GsmBurst_1slot`.
33. Adjust the level of the MG3700A so that the power meter reads $-50 \text{ dBm} \pm 0.2 \text{ dB}$. Record the adjusted power reading into the “Adjusted Output Power” row of [Table A-68](#), “[Option 40, At 1800 MHz, \$-50 \text{ dBm}\$ Level, TCH Pattern \(GSM\)](#)” on page A-36. Then wait 15 seconds to allow the MS272xC to update its measured results.
34. For MS272xC with Option 40 (GSM/GPRS/EDGE RF Measurements), record the measured value into the “Displayed Burst Power” row of [Table A-68](#), then subtract the “Displayed Burst Power” value from the “Adjusted Output Power” reading that was obtained in Step 33. Then record the “Calculated Burst Power Error” and the displayed value of “Frequency Error” into [Table A-68](#).
35. For MS272xC with Option 41 (GSM/GPRS/EDGE Demodulator), record the displayed Phase Err RMS (deg) into [Table A-76](#), “[Option 41, At 1800 MHz, \$-50 \text{ dBm}\$ Level, TCH Pattern \(GSM\)](#)” on page A-38.
36. Verify that the measured values in Step 34 or Step 35 or both are within specifications.

EDGE Burst Power, Frequency Error and Residual Error Tests

Test Procedure

1. Verify that the equipment settings are unchanged from the previous test.
2. On the MG3700A, change the selected pattern to DL_MCS-9_1SLOT.
3. Adjust the level of the MG3700A so that the power meter reads $-50 \text{ dBm} \pm 0.2 \text{ dB}$. Record the adjusted power reading into the “Adjusted Output Power” row of [Table A-69, “Option 40, At 1800 MHz, \$-50 \text{ dBm}\$ Level, DL_MCS-9_1SLOT Pattern \(EDGE\)”](#) on page A-36. Then wait 15 seconds to allow the MS272xCto update its measured results.
4. For MS272xC with Option 40 (GSM/GPRS/EDGE RF Measurements), record the measured value into the “Displayed Burst Power” row of [Table A-69](#), then subtract the “Displayed Burst Power” value from the “Adjusted Output Power” reading that was obtained in Step 3. Then record the “Calculated Burst Power Error” and the displayed value of “Frequency Error” into [Table A-69](#).
5. For MS272xC with Option 41 (GSM/GPRS/EDGE Demodulator), record the displayed EVM(rms) into [Table A-77, “Option 41, At 1800 MHz, \$-50 \text{ dBm}\$ Level, DL_MCS-9_1SLOT Pattern \(EDGE\)”](#) on page A-38.
6. Verify that the measured values in Step 4 and Step 5 are within specifications.
7. On the MG3700A, change the selected pattern to DL_MCS-9_4SLOT.
8. Adjust the level of the MG3700A so that the power meter reads $-10 \text{ dBm} \pm 0.2 \text{ dB}$. Record the adjusted power reading into the “Adjusted Output Power” row of [Table A-70, “Option 40, At 1800 MHz, \$-10 \text{ dBm}\$ Level, DL_MCS-9_4SLOT Pattern \(EDGE\)”](#) on page A-36. Then wait 15 seconds to allow the MS272xC to update its measured results.
9. For MS272xC with Option 40 (GSM/GPRS/EDGE RF Measurements), record the measured value into the “Displayed Burst Power” row of [Table A-70](#), then subtract the “Displayed Burst Power” value from the “Adjusted Output Power” reading that was obtained in Step 8. Then record the “Calculated Burst Power Error” and the displayed value of “Frequency Error” into [Table A-70](#).
10. For MS272xC with Option 41 (GSM/GPRS/EDGE Demodulator), record the displayed EVM(rms) into [Table A-78, “Option 41, At 1800 MHz, \$-10 \text{ dBm}\$ Level, DL_MCS-9_4SLOT Pattern \(EDGE\)”](#) on page A-38.
11. Verify that the measured values in Step 9 and Step 10 are within specifications.
12. Change the frequency of MG3700A to 850 MHz.
13. On the power meter, press the **Sensor** key, the Cal Factor submenu key, and then the Freq submenu key. Use the keypad to enter 850 MHz as the input signal frequency, which sets the power meter to the proper power sensor calibration factor. Press the **System** key to display the power reading.
14. Adjust the level of the MG3700A so that the power meter reads $-50 \text{ dBm} \pm 0.2 \text{ dB}$. Record the adjusted power reading into the “Adjusted Output Power” row of [Table A-71, “Option 40, At 850 MHz, \$-50 \text{ dBm}\$ Level, DL_MCS-9_4SLOT Pattern \(EDGE\)”](#) on page A-37.
15. On the MS272xC, set the Center Freq to 850 MHz. Then wait 15 seconds to allow the MS272xC to update its measured results.
16. For MS272xC with Option 40 (GSM/GPRS/EDGE RF Measurements), record the measured value into the “Displayed Burst Power” row of [Table A-71](#), then subtract the “Displayed Burst Power” value from the “Adjusted Output Power” reading that was obtained in Step 14. Then record the “Calculated Burst Power Error” and the displayed value of “Frequency Error” into [Table A-71](#).
17. For MS272xC with Option 41 (GSM/GPRS/EDGE Demodulator), record the displayed EVM(rms) into [Table A-79, “Option 41, At 850 MHz, \$-50 \text{ dBm}\$ Level, DL_MCS-9_4SLOT Pattern \(EDGE\)”](#) on page A-39.
18. Verify that the measured values in Step 16 and Step 17 are within specifications.
19. On the MG3700A, change the selected pattern to DL_MCS-9_1SLOT.

20. Adjust the level of the MG3700A so that the power meter reads $-10 \text{ dBm} \pm 0.2 \text{ dB}$. Record the adjusted power reading into the “Adjusted Output Power” row of [Table A-72, “Option 40, At 850 MHz, \$-10 \text{ dBm}\$ Level, DL_MCS-9_1SLOT Pattern \(EDGE\)”](#) on page A-37. Then wait 15 seconds to allow the MS272xC to update its measured results.
21. For MS272xC with Option 40 (GSM/GPRS/EDGE RF Measurements), record the measured value into the “Displayed Burst Power” row of [Table A-72](#), then subtract the “Displayed Burst Power” value from the “Adjusted Output Power” reading that was obtained in Step 20. Then record the “Calculated Burst Power Error” and the displayed value of “Frequency Error” into [Table A-72](#).
22. For MS272xC with Option 41 (GSM/GPRS/EDGE Demodulator), record the displayed EVM(rms) into [Table A-80, “Option 41, At 850 MHz, \$-10 \text{ dBm}\$ Level, DL_MCS-9_1SLOT Pattern \(EDGE\)”](#) on page A-39
23. Verify that the measured values in Step 21 and Step 22 are within specifications.

3-4 Option 42 and/or 43, CDMA Signal Analyzer Verification

The tests in this section verify the optional CDMA Signal Analyzer functions in Model MS272xC Spectrum Master.

Equipment Required for MS2722C, MS2723C and MS2724C

- Anritsu MG3700A Vector Signal Generator
- Frequency Reference Symmetricom Rubisource T&M
- Power Meter, Anritsu Model ML2438A
- Power Sensor, Anritsu Model SC7400
- Anritsu 34NN50A 50 ohm Adapter (2)
- Anritsu 15NN50-1.5C RF Coaxial Cable
- BNC male to BNC male Coaxial Cable
- Power Splitter, Aeroflex/Weinschel Model 1870A

Equipment Required for MS2725C and MS2726C

- All of the above
- Anritsu 71693-R Ruggedized K(f) to N(f) Adapter

Setup

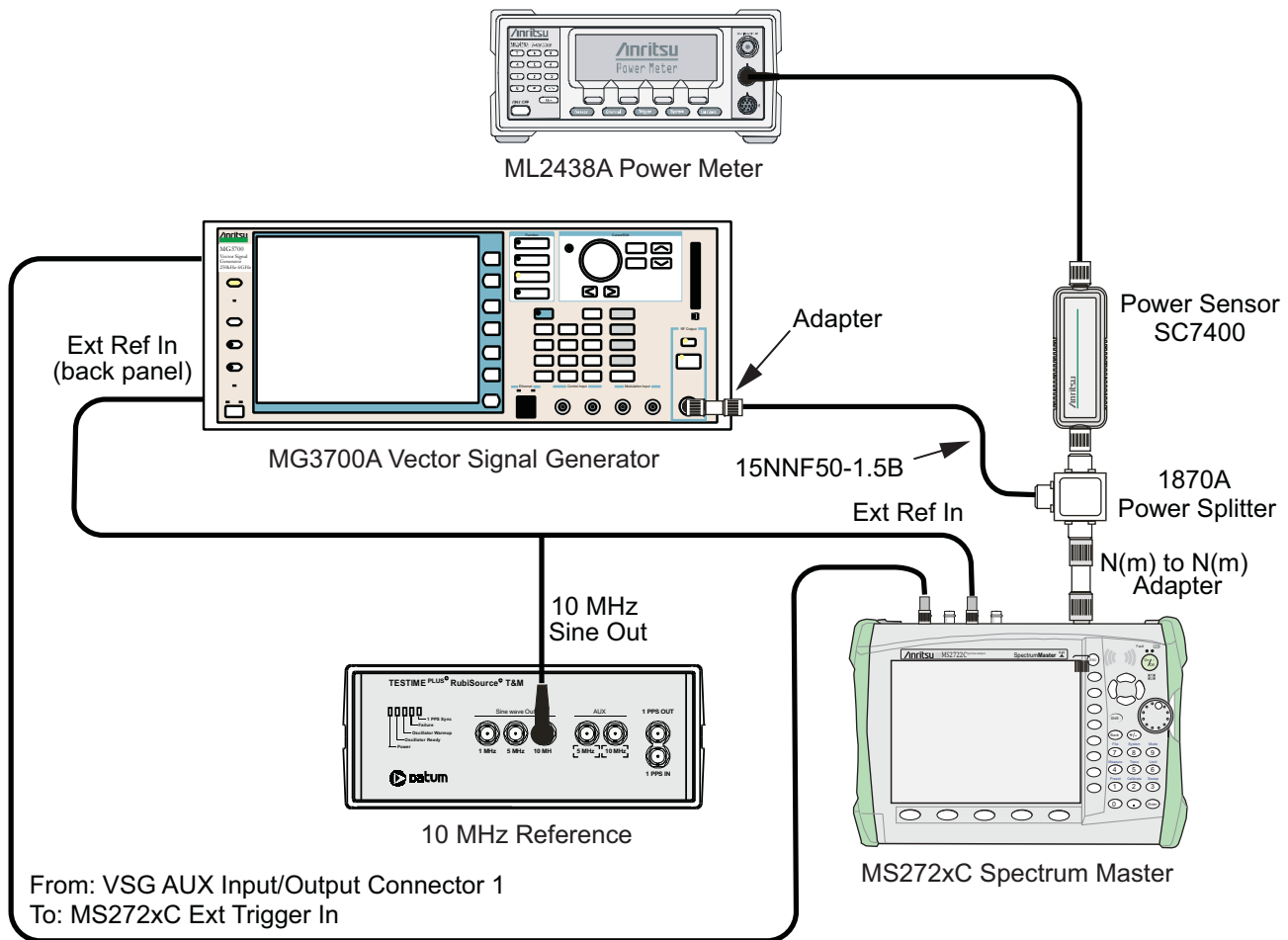

Figure 3-3. CDMA Signal Analyzer, Test Setup

Set up Procedure

1. Zero the power sensor prior to connecting it to the power splitter.
2. Set the Power Meter Measurement MODE to True RMS, set Averaging MODE to Moving, and set Averaging NUMBER to 256.
3. Connect the equipment as shown in [Figure 3-3](#).
4. On the power meter, press the **Sensor** key, the Cal Factor submenu key, and then the Freq submenu key. Use the keypad to enter 870.03 MHz as the input signal frequency, which sets the power meter to the proper power sensor calibration factor. Press the **System** key to display the power reading.
5. Set the MS272xC mode to CDMA Signal Analyzer. Preset the instrument.

cdmaOne Channel Power, Frequency Error, Rho and Tau Tests

Test Procedure

1. On the MG3700A, press the **Preset** key (Yellow key on the upper-left corner).
2. Press the **Down Arrow** key or turn the knob to select **Yes**.
3. Press the **Set** key (Note that two Set keys are available, and they both do the same thing).
4. Press the (F1) submenu key to select “Load File to Memory”.
5. Press the (F1) submenu key again to select “Select Package”.
6. Using the **Down Arrow** key, step through the selection list until the CDMA2000 option is highlighted.
7. Press the **Set** key.
8. Press the (F6) submenu key Return.
9. Press the **Set** key. The “Select Package” box is displayed. Use the rotary knob to highlight CDMA2000 and press the **Set** key to select.
10. Another File List is displayed. Use the rotary knob to select FWD_RC1-2_9channel and press the **Set** key to select.
11. Press the **MOD On/Off** key to turn the Modulation LED On and verify that the “Playing” indicator in the center of the LCD is flashing.
12. Press the Frequency key, enter 870.03 MHz.
13. Press the **Level** key, enter -30, and press the **dBm** key.
14. Adjust the MG3700A output so that the power meter reads $-30 \text{ dBm} \pm 0.2 \text{ dB}$. Record the adjusted “Power Meter Reading” into [Table A-81, “Option 42, At 870.03 MHz, -30 dBm Level, cdmaOne” on page A-40](#).
15. On the MS272xC, press the **Freq** main menu key and enter 870.03 MHz as Center Freq.
16. Press the **Measurements** main menu key and press CDMA Summary (a red dot is displayed on the label).
17. Press the **Setup** main menu key and press PN Setup. Then change PN Trigger to Ext by pressing the PN Trigger submenu key twice. Wait 15 seconds to allow the MS272xC to update its measured results.
18. For MS272xC with Option 42 (CDMA RF Measurements), record the “Channel Power Value” into [Table A-81](#), and subtract the displayed “Channel Power Value” from the adjusted “Power Meter Reading” in Step 14. Then record the calculated “Channel Power Error” into [Table A-81](#).
19. For MS272xC with Option 43 (cdmaOne and CDMA2000 1xRTT Demodulator), record the displayed Freq Error, Rho, and Tau into [Table A-85, “Option 43, At 870.03 MHz, -30 dBm Level, cdmaOne” on page A-41](#).
20. Verify that the measured values in Step 18 and Step 19 are within specifications.

21. On the power meter, press the **Sensor** key, the Cal Factor submenu key, and then the Freq submenu key. Use the keypad to enter 1930 MHz as the input signal frequency, which sets the power meter to the proper power sensor calibration factor. Press the **System** key to display the power reading.
22. Set the MG3700A Frequency to 1930.05 MHz.
23. Adjust the MG3700A output so that the power meter reads $-30 \text{ dBm} \pm 0.2 \text{ dB}$. Record the adjusted “Power Meter Reading” into [Table A-82, “Option 42, At 1930.05 MHz, \$-30 \text{ dBm}\$ Level, cdmaOne” on page A-40.](#)
24. On the MS272xC, press the **Freq** main menu key, and enter 1930.05 MHz as Center Freq. Then wait 15 seconds to allow the MS272xC to update its measured results.
25. For MS272xC with Option 42 (CDMA RF Measurements), record the “Channel Power Value” into [Table A-82](#), and subtract the displayed “Channel Power Value” from the adjusted “Power Meter Reading” in Step 23. Then record the calculated “Channel Power Error” into [Table A-82](#).
26. For MS272xC with Option 43 (cdmaOne and CDMA2000 1xRTT Demodulator), record the displayed Freq Error, Rho, and Tau into [Table A-86, “Option 43, At 1930.05 MHz, \$-30 \text{ dBm}\$ Level, cdmaOne” on page A-41.](#)
27. Verify that the measured values in Step 25 and Step 26 are within specifications.

CDMA2000 Channel Power, Frequency Error, Rho and Tau Tests

Test Procedure

1. Verify that the equipment settings are unchanged from the previous test.
2. On the MG3700A, change the selected pattern to “FWD_RC3-5_9channel”.
3. Adjust the level of the MG3700A so that the power meter reads $-30 \text{ dBm} \pm 0.2 \text{ dB}$. Record the adjusted “Power Meter Reading” into [Table A-83, “Option 42, At 1930.05, \$-30 \text{ dBm}\$ Level, CDMA2000” on page A-40.](#) Then wait 15 seconds to allow the MS272xC to update its measured results.
4. For MS272xC with Option 42 (CDMA RF Measurements), record the “Channel Power Value” into [Table A-83](#), and subtract the displayed “Channel Power Value” from the adjusted “Power Meter Reading” in Step 3. Then record the calculated “Channel Power Error” into [Table A-83](#).
5. For MS272xC with Option 43 (cdmaOne and CDMA2000 1xRTT Demodulator), record the displayed Freq Error, Rho and Tau into [Table A-87, “Option 43, At 1930.05 MHz, \$-30 \text{ dBm}\$ Level, CDMA2000” on page A-41.](#)
6. Verify that the measured values in Step 4 and Step 5 are within specifications.
7. On the power meter, press the **Sensor** key, the Cal Factor submenu key, and then the Freq submenu key. Use the keypad to enter 870.03 MHz as the input signal frequency, which sets the power meter to the proper power sensor calibration factor. Press the **System** key to display the power reading.
8. Set the MG3700A Frequency to 870.03 MHz.
9. Adjust the MG3700A output so that the power meter reads $-30 \text{ dBm} \pm 0.2 \text{ dB}$. Record the adjusted “Power Meter Reading” into [Table A-84, “Option 42, At 870.03 MHz, \$-30 \text{ dBm}\$ Level, CDMA2000” on page A-40.](#)
10. On the MS272xC, press the **Freq** main menu key, and enter 870.03 MHz as Center Freq. Then wait 15 seconds to allow the MS272xC to update its measured results.
11. For MS272xC with Option 42 (CDMA RF Measurements), record the “Channel Power Value” into [Table A-84](#), and subtract the displayed “Channel Power Value” from the adjusted “Power Meter Reading” in Step 9. Then record the calculated “Channel Power Error” into [Table A-84](#).
12. For MS272xC with Option 43 (cdmaOne and CDMA2000 1xRTT Demodulator), record the displayed Freq Error, Rho and Tau into [Table A-88, “Option 43, At 870.03 MHz, \$-30 \text{ dBm}\$ Level, CDMA2000” on page A-41.](#)
13. Verify that the measured values in Step 11 and Step 12 are within specifications.

3-5 Option 44, 45, and/or 65 WCDMA/HSDPA Signal Analyzer Verification

The tests in this section can be used to verify the functionality of the WCDMA/HSDPA Signal Analyzer mode of the MS272xC Spectrum Master. The tests include:

- “WCDMA Absolute Power Accuracy Verification (Option 44) ”
- “WCDMA Occupied Bandwidth (OBW) Verification (Option 44) ” on page 3-18
- “WCDMA RF Channel Power Accuracy and ACLR Verification (Option 44) ” on page 3-20
- “HSDPA RF Channel Power Accuracy and ACLR Verification (Option 44) ” on page 3-21
- “Error Vector Magnitude (EVM) Verification (Option 45 or Option 65) ” on page 3-22

WCDMA Absolute Power Accuracy Verification (Option 44)

This test verifies the WCDMA absolute power accuracy in WCDMA/HSDPA Signal Analyzer Mode.

Equipment Required for MS2722C, MS2723C and MS2724C

- Anritsu MG3700A Vector Signal Generator
- Frequency Reference Symmetricom Rubisource T&M
- Mini Circuits Model TIA10001R8 RF Power Amplifier
- Programmable Attenuator, Anritsu Model MN63A
- Circulator (refer to [Table 1-3 on page 1-4](#))
- High Power Load, Aeroflex/Weinschel Model M1418
- Coupler (refer to [Table 1-3](#))
- Power Meter, Anritsu Model ML2438A
- Power Sensor, Anritsu Model SC7400 (2)
- Anritsu 34NN50A 50 ohm Adapter (2)
- Anritsu 15NN50-1.5C RF Coaxial Cable
- BNC male to BNC male Coaxial Cable

Equipment Required for MS2725C and MS2726C

- All of the above
- Anritsu 71693-R Ruggedized K(f) to N(f) Adapter

Setup

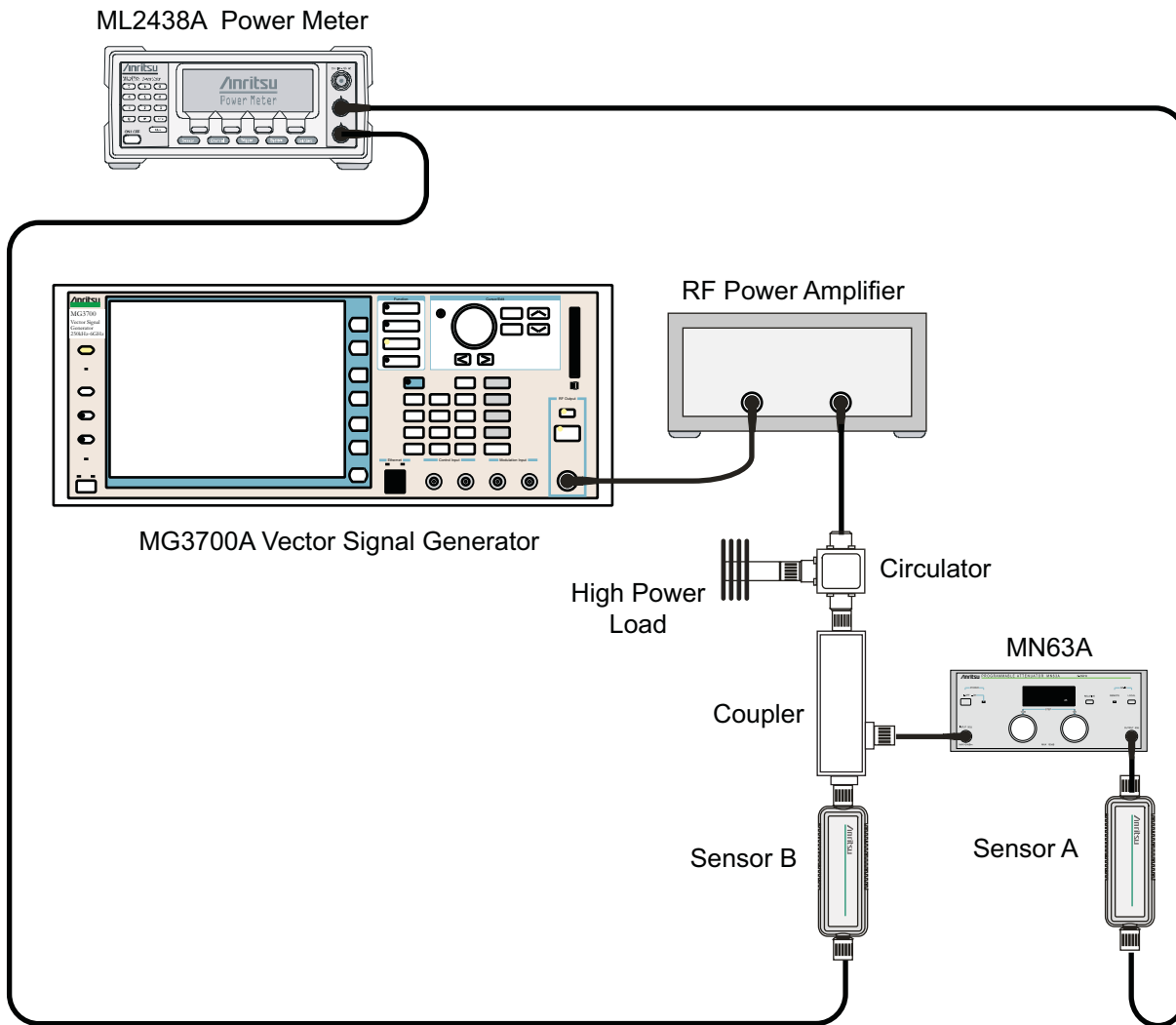

Figure 3-4. WCDMA/HSDPA Signal Analyzer, Characterization Setup

Procedure

1. Connect the MG3700A, RF power amplifier, circulator, load, coupler, and programmable attenuator as shown in [Figure 3-4](#).
2. Turn on the MG3700A, RF amplifier, attenuator, and the power meter.
3. Connect the power sensors to the power meter and then zero the sensors. Then connect the sensors as shown in [Figure 3-4](#).
4. Press the **On/Off** key to turn on the MS272xC and wait until the measurement display appears. Then press the **Shift** key, and press the **Mode** (9) key to activate the mode selection menu.
5. Use the **Up/Down** arrow keys to select WCDMA, and press the **Enter** key.
6. Press the **Shift** key, the **Preset** (1) key, and then the Preset submenu key.
7. On the MG3700A, press the **Preset** key (Yellow key on the upper left corner).
8. Press the **Down Arrow** key to select Yes.
9. Press the **Set** key (Note that two Set keys are available, and they both do the same thing).

10. Press the (F1) submenu key to select “Load File to Memory”
11. Press the (F1) submenu key again to select “Select Package”
12. Using the **Down Arrow** key, step through the selection list until the WCDMA(BS Tx test) option is highlighted.
13. Press the **Set** key.
14. Press the (F6) submenu key, Return.
15. Press the **Set** key.
16. Using the **Down Arrow** key, step through the selection list until the TestModle_1_16DPCH option is highlighted.
17. Press the **Set** key.
18. Press the **MOD On/Off** key and verify that the Modulation indicator on the display is On.
19. Press the **Frequency** key, enter 881.5, then press the **MHz** key.
20. Press the **Level** key, enter -28, and press the **dBm** key.
21. Use the knob to adjust the power level so that Sensor B reads +10 dBm.
22. Set the MN63A attenuator to 0 dB.
23. Record the Sensor A reading (PMA.10) in [Table A-89, “Option 44, Sensor A and Sensor B Readings, Components Characterization” on page A-42](#). This should be approximately -20 dBm.
24. Record the Sensor B reading (PMB.10) in [Table A-89](#).
25. Calculate Delta 1 ($\Delta 1$), which is the error of the coupler output port deviation from ideal + 10 dBm, by using the following formula:
$$\text{Delta 1 (dBm)} = (10 \text{ dBm} - \text{PMB.10})$$
26. Record the Delta 1 ($\Delta 1$) value in [Table A-89](#).
27. Calculate the accurate value of the Sensor A reading for coupler port output of +10 dBm (PMA.10C) by using the following formula:
$$\text{PMA.10C} = \text{PMA.10} + \Delta 1$$
28. Record the calculated value (PMA.10C) in [Table A-89](#).
29. Set the MN63A attenuator to 18 dB, and record the Sensor A reading (PMA.18) in [Table A-89](#).
30. Calculate the accurate attenuation value by using the following formula:
$$\text{ATT.18} = (\text{PMA.10} - \text{PMA.18})$$
31. Record the calculated value (ATT.18) in [Table A-89](#).
32. Turn off the RF output of the MG3700A.
33. Disconnect the coupler from Sensor B and connect the coupler to the MS272xC, refer to [Figure 3-5 on page 3-16](#).
34. Set the MN63A attenuator to 0 dB.
35. On the MS272xC, press the Center Freq submenu key, enter 881.5, and then press the **Enter** key.
36. Press the **Measurements** main menu key, then the RF Measurement submenu key, then the Spectrum submenu key.
37. On the MG3700A, turn on the RF output and use the knob to adjust power level to read the value of PMA.10C on Sensor A (refer to [Table A-89](#)).
38. Record the MG3700A power level setting (MG3700A.10) in [Table A-90, “Option 44, Power Level Setting, Components Characterization” on page A-42](#).

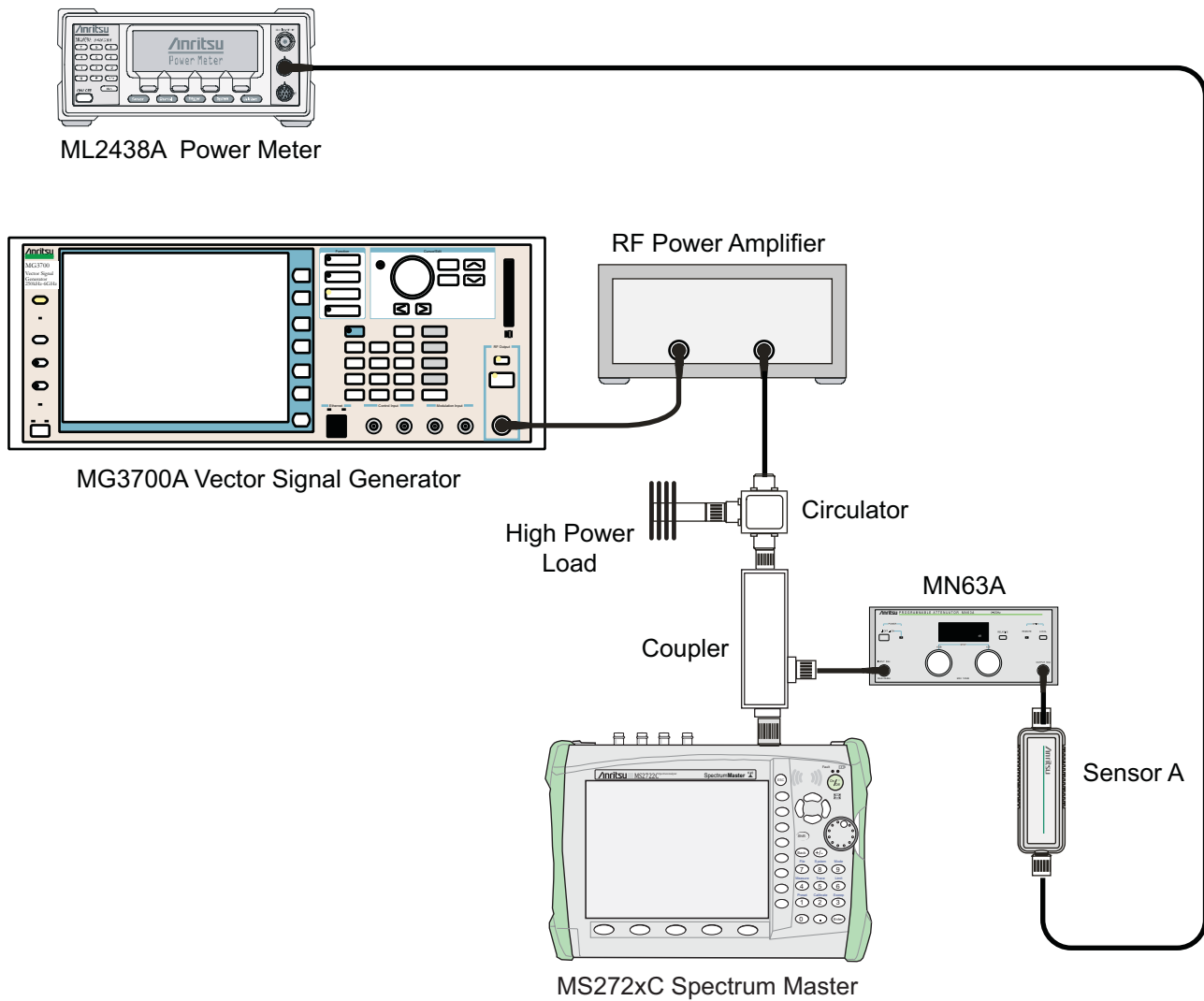

Figure 3-5. WCDMA/HSDPA Signal Analyzer, Test Setup for Spectrum Master

39. On the MS272xC, press the **Amplitude** main menu key and then press the Adjust Range submenu key.
40. Record the channel power reading into the “Measured Power” column of [Table A-91, “Option 44, WCDMA Absolute Power Accuracy”](#) on page A-42.
41. Use the following formula to calculate the Error value for the absolute power accuracy of the MS272xC at +10 dBm:

$$\text{Error} = \text{Measured Power} - 10$$

42. Record the calculated Error value into the “Error” column of [Table A-91](#), and verify that it is within the listed specification.
43. Turn Off the RF output of the MG3700A.
44. Set the MN63A attenuator to 18 dB.
45. Calculate the value of the MG3700A setting (MG3700A.28) for +28 dBm Test Level by using the following formula:

$$\text{MG3700A.28} = \text{MG3700A.10} + \text{ATT.18}$$

46. Record the calculated value (MG3700A.28) in [Table A-90](#), “Option 44, Power Level Setting, Components Characterization” on page A-42.
47. On the MG3700A, turn on the RF output and use the knob to adjust power level to the recorded MG3700A.28 value in [Table A-90](#).
48. On the MS272xC, press the **Amplitude** main menu key and then press the Adjust Range submenu key.
49. Record channel power reading in the “Measured Power” column of [Table A-91](#).
50. Use the following formula to calculate the absolute power accuracy of the MS272xC at +28 dBm:
$$\text{Error} = \text{Measured Power} - 28$$
51. Record the calculated value in the “Error” column of [Table A-91](#), and verify that it is within the listed specification.
52. Turn off the RF output of the MG3700A.
53. Set the MN63A attenuator to 0 dB.
54. Set power level of the MG3700A to -38 dBm.
55. Calculate the value of the Sensor A reading (PMA - 10) for -10 dBm Test Level by using the following formula:
$$\text{PMA}-10 = \text{PMA.10C}-20$$
56. Record the calculated value (PMA - 10) in [Table A-90](#).
57. Turn on the RF output and use the knob to adjust power level to read the value of PMA - 10 on Sensor A.
58. On the MS272xC, press the **Amplitude** main menu key and then press the Adjust Range submenu key.
59. Record channel power reading in the “Measured Power” column of [Table A-91](#).
60. Use the following formula to calculate the absolute power accuracy of the MS272xCat -10 dBm:
$$\text{Error} = \text{Measured Power} - (-10)$$
61. Record the calculated value in the “Error” column of [Table A-91](#), and verify that it is within the listed specification.
62. Turn Off the RF output of the MG3700A.
63. Set the MN63A attenuator to 0 dB.
64. Decrease power level of the MG3700A by 10 dB.
65. Calculate the value of the Sensor A reading (PMA - 20) for -20 dBm Test Level by using the following formula:
$$\text{PMA}-20 = \text{PMA.10C}-30$$
66. Record the calculated value (PMA - 20) in [Table A-90](#).
67. Turn on the RF output and use the knob to adjust power level to read the value of PMA - 20 on Sensor A.
68. On the MS272xC, press the **Amplitude** main menu key and then press the Adjust Range submenu key.
69. Record channel power reading in the “Measured Power” column of [Table A-91](#).
70. Turn off the RF output of the MG3700A.
71. Use the following formula to calculate the absolute power accuracy of MS272xC at -20 dBm:
$$\text{Error} = \text{Measured Power} - (-20)$$
72. Record the calculated value in the “Error” column of [Table A-91](#), and verify that it is within the listed specification.

WCDMA Occupied Bandwidth (OBW) Verification (Option 44)

The tests in this section can be used to verify the WCDMA occupied bandwidth in WCDMA/HSDPA Signal Analyzer Mode.

Equipment Required for MS2722C, MS2723C and MS2724C

- Anritsu MG3700A Vector Signal Generator
- Frequency Reference Symmetricom Rubisource T&M
- Power Meter, Anritsu Model ML2438A
- Power Sensor, Anritsu Model SC7400
- Power Splitter, Aeroflex/Weinschel Model 1870A
- Fixed Attenuator, Aeroflex/Weinschel Model 4410 (2)
- Anritsu 34NN50A 50 ohm Adapter (2)
- Anritsu 15NN50-1.5C RF Coaxial Cable
- BNC male to BNC male Coaxial Cable

Equipment Required for MS2725C and MS2726C

- All of the above
- Anritsu 71693-R Ruggedized K(f) to N(f) Adapter

Setup

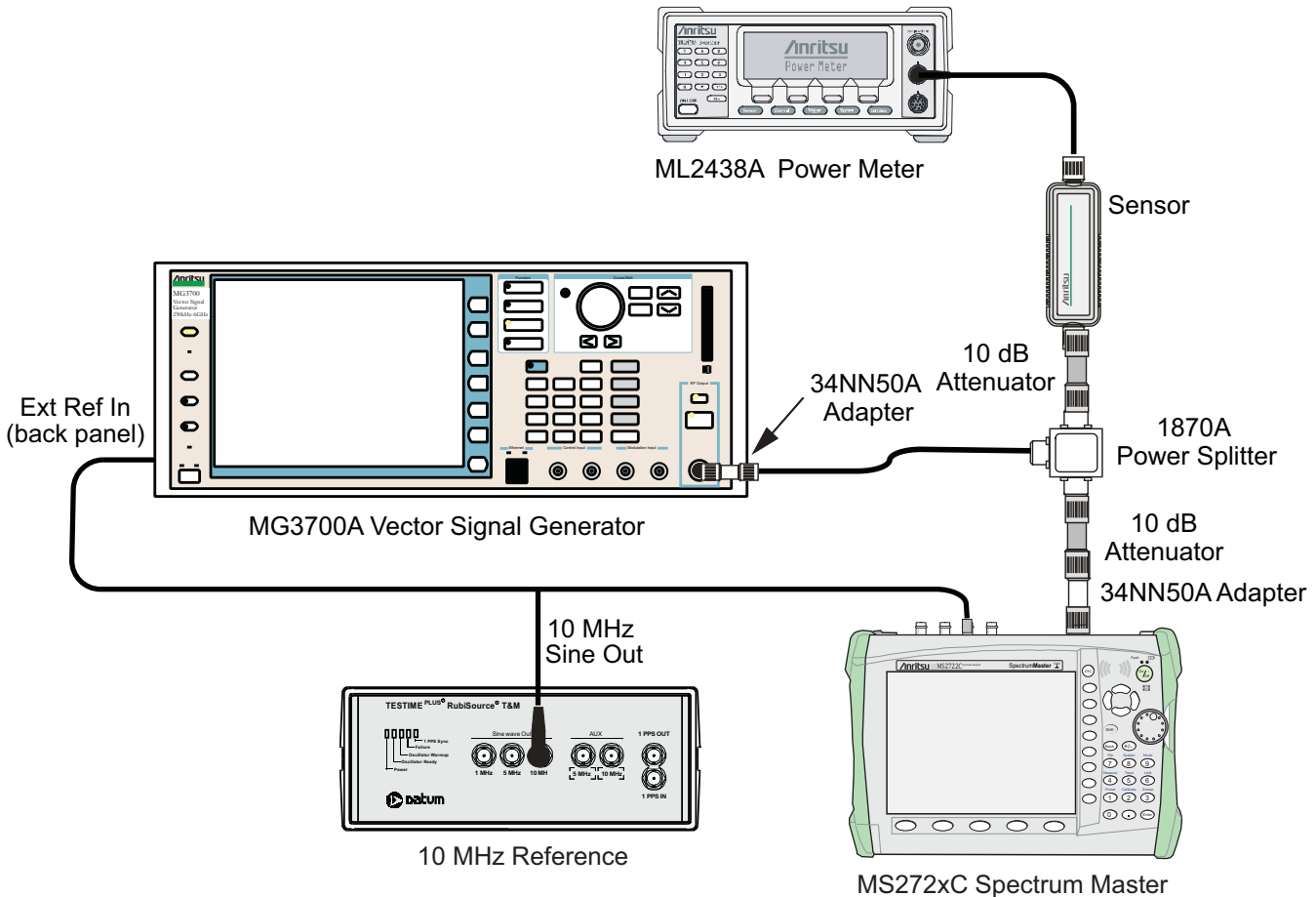

Figure 3-6. WCDMA Occupied Bandwidth, Test Setup

Procedure

1. Turn on the MG3700A Vector Signal Generator and the ML2438A power meter.
2. Connect the power sensor to the power meter and calibrate the sensor.
3. Connect the MG3700A, splitter, attenuator, power meter, and sensor as shown in [Figure 3-6](#).
4. Press the **On/Off** key to turn on the MS272xC and wait until the measurement display appears. Then press the **Shift** key then press the **Mode** (9) key to activate the mode selection menu.
5. Use the **Up/Down** arrow keys to select WCDMA and press the **Enter** key.
6. Press the **Shift** key, the **Preset** (1) key, and then the **Preset** submenu key.
7. On the MG3700A, press the **Preset** key (Yellow key on the upper-left corner).
8. Press the **Down Arrow** key to select **Yes**.
9. Press the **Set** key (Note that two Set keys are available, and they both do the same thing).
10. Press the (F1) submenu key to select “Load File to Memory”
11. Press the (F1) submenu key again to select “Select Package”
12. Using the **Down Arrow** key, step through the selection list until the WCDMA(BS Tx test) option is highlighted.
13. Press the **Set** key.
14. Press the (F6) submenu key, **Return**.
15. Press the **Set** key.
16. Using the **Down Arrow** key, step through the selection list until the TestModle_1_16DPCH option is highlighted.
17. Press the **Set** key.
18. Press the **MOD On/Off** key and verify that the Modulation indicator on the display is On.
19. Press the **Frequency** key, then enter the frequencies from [Table A-92](#), “[Option 44, WCDMA Occupied Bandwidth \(OBW\)](#)” on [page A-42](#), starting with 881.5, and press the **MHz** key.
20. Press the **Level** key, then enter -2, and press the **dBm** key.
21. Use the knob to adjust the power level so that the power meter reads -20 dBm. Record the reading in the “Power Meter Reading” column of [Table A-92](#).
22. On MS272xC, press the **Center Freq** submenu key, and enter the frequencies from [Table A-92](#), starting with 881.5 MHz, then press the **Enter** key.
23. Press the **Measurements** main menu key, then the **RF Measurement** submenu key, and press **Channel Spectrum** submenu key.
24. Press the **Amplitude** main menu key, then press the **Adjust Range** submenu key.
25. Record the OBW reading in the “OBW” column of [Table A-92](#) and verify that it is within $4.2 \text{ MHz} \pm 100 \text{ kHz}$.
26. Repeat Step 19 through Step 25 for the other frequencies in [Table A-92](#).

WCDMA RF Channel Power Accuracy and ACLR Verification (Option 44)

The tests in this section can be used to verify the WCDMA RF Channel Power Accuracy and Adjacent Channel Leakage Ratio (ACLR) Accuracy in WCDMA/HSDPA Signal Analyzer Mode.

Procedure

1. Turn on the MG3700A Vector Signal Generator and the ML2438A power meter.
2. Connect the power sensor to the power meter and zero the sensor.
3. Connect the MG3700A, splitter, attenuator, power meter, and sensor as shown in [Figure 3-6](#).
4. Press the **On/Off** key to turn on the MS272xC and wait until the measurement display appears. Then press the **Shift** key, and then press the **Mode** (9) key to activate the mode selection menu.
5. Use the **Up/Down** arrow keys to select WCDMA, and press the **Enter** key.
6. Press the **Shift** key, the **Preset** (1) key, and then the Preset submenu key.
7. On the MG3700A, press the **Preset** key (Yellow key on the upper-left corner).
8. Press the **Down Arrow** key to select Yes.
9. Press the **Set** key (Note that two Set keys are available, and they both do the same thing).
10. Press the (F1) submenu key to select “Load File to Memory”.
11. Press the (F1) submenu key again to select “Select Package”.
12. Using the **Down Arrow** key, step through the selection list until the WCDMA(BS Tx test) option is highlighted.
13. Press the **Set** key.
14. Press the (F6) submenu key, Return.
15. Press the **Set** key.
16. Using the **Down Arrow** key, step through the selection list until the TestModel_1_16DPCH option is highlighted.
17. Press the **Set** key.
18. Press the **MOD On/Off** key, and verify that the Modulation indicator on the display is On.
19. Press the **Frequency** key, then enter 881.5, and press the **MHz** key.
20. Press the **Level** key, then enter -2, and press the **dBm** key.
21. Use the knob to adjust the power meter to read -20 dBm, and record the Power Meter reading in the “Power Meter Reading” column of [Table A-93, “Option 44, WCDMA RF Channel Power Accuracy” on page A-43](#).
22. On the MS272xC, press the Center Freq submenu key, enter 881.5, and then press the **Enter** key.
23. Press the **Measurements** main menu key, then the RF Measurement submenu key, and press ACLR.
24. Press the **Amplitude** main menu key, then press the Adjust Range submenu key.
25. Record the measured CH 1 power into the “Measured RF Channel Power” column of [Table A-93](#).
26. Calculate the RF Channel Power Error using the following formula:

$$\text{RF Channel Power Error (dB)} = \text{Measured RF Channel Power} - 0.246 - \text{Power Meter reading}$$
27. Record calculated value to the “RF Channel Power Error” column of [Table A-93](#), and verify that it is within specifications (± 1.25 dB).
28. Record all four measured Adjacent Channel Leakage Ratios in dB at -10 MHz Offset, -5 MHz Offset, 5 MHz Offset, and 10 MHz Offset into the “Measured ACLR” column of [Table A-94, “WCDMA ACLR Accuracy” on page A-43](#).

29. Calculate the ACLR Error at –10 MHz and +10 MHz Offset using the following formula:

$$\text{ACLR Error at } -10 \text{ or } 10 \text{ MHz Offset} = 10 \text{ LOG}_{10}(10^{(-50/10)} + 10^{(\text{Measured_ACLR}/10)}) - (-50) \text{ dB}$$

30. Record the calculated results into the corresponding cells in the “Calculated ACLR Error” column in [Table A-94](#) and verify that it is within specification.

31. Calculate the ACLR Error at –5 MHz Offset and +5 MHz Offset by using the following formula:

$$\text{ACLR Error at } -5 \text{ or } 5 \text{ MHz Offset} = 10 \text{ LOG}_{10}(10^{(-45/10)} + 10^{(\text{Measured_ACLR}/10)}) - (-45) \text{ dB}$$

32. Record the calculated results into the corresponding cells in [Table A-94](#) and verify that they are within specification.

33. Repeat Step 19 through Step 32 for the other frequencies.

HSDPA RF Channel Power Accuracy and ACLR Verification (Option 44)

The tests in this section can be used to verify the RF Channel Power Accuracy and Adjacent Channel Leakage Ratio (ACLR) Accuracy for HSDPA signals in WCDMA/HSDPA Signal Analyzer Mode.

Procedure

1. Turn on the MG3700A Vector Signal Generator and the ML2438A power meter.
2. Connect the power sensor to the power meter and zero the sensor.
3. Connect the MG3700A, splitter, attenuator, power meter, and sensor according to
4. Press the **On/Off** key to turn on the MS272xC, and wait until the measurement display appears. Then press the **Shift** key, and then press the **Mode** (9) key to activate the mode selection menu.
5. Use the **Up/Down** arrow keys to select WCDMA, and press the **Enter** key.
6. Press the **Shift** key, the **Preset** (1) key, and then the **Preset** submenu key.
7. On the MG3700A, press the **Preset** key (Yellow key on the upper-left corner).
8. Press the **Down Arrow** key to select Yes.
9. Press the **Set** key (Note that two Set keys are available, and they both do the same thing).
10. Press the (F1) submenu key to select “Load File to Memory”
11. Press the (F1) submenu key again to select “Select Package”
12. Using the **Down Arrow** key, step through the selection list until the WCDMA(BS Tx test) option is highlighted.
13. Press the **Set** key.
14. Press the (F6) submenu key, Return.
15. Press the **Set** key.
16. Using the **Down Arrow** key, step through the selection list until the TestModel_5_8HSPDSCH option is highlighted.
17. Press the **Set** key.
18. Press the **MOD On/Off** key and verify that the Modulation indicator on the display is On.
19. Press the **Frequency** key, then enter 2680.5, and press the **MHz** key.
20. Press the **Level** key, then enter –2, and press the **dBm** key.
21. Use the knob to adjust the power meter to read –20 dBm, and record the Power Meter reading in the “Power Meter Reading” column of [Table A-95](#), “[Option 44, HSDPA RF Channel Power Accuracy](#)” on [page A-43](#).
22. On the MS272xC, press the Center Freq submenu key, enter 2680.5, and then press the **Enter** key.

23. Press the **Measurements** main menu key, then the RF Measurement submenu key, and press ACLR.
24. Press the **Amplitude** main menu key, then press the Adjust Range submenu key.
25. Record the measured CH 1 power in dBm to the “Measured RF Channel Power” column of [Table A-94](#).
26. Calculate the RF Channel Power Error using the following formula:

$$\text{RF Channel Power Error (dB)} = \text{Measured RF Channel Power} - 0.246 - \text{Power Meter reading}$$
27. Record the calculated value into the “RF Channel Power Error” column in [Table A-94](#) and verify that it is within specifications (± 1.25 dB).
28. Record all four measured Adjacent Channel Leakage Ratios in dB at -10 MHz Offset, -5 MHz Offset, 5 MHz Offset, and 10 MHz Offset in the “Measured ACLR” column of [Table A-96](#), “[Option 44, HSDPA ACLR Accuracy](#)” on page A-44.
29. Calculate the ACLR Error at -10 MHz Offset and 10 MHz Offset using the following formula:

$$\text{ACLR Error at } -10 \text{ or } 10 \text{ MHz Offset} = 10 \text{ LOG}_{10}(10^{(-50/10)} + 10^{(\text{Measured_ACLR}/10)}) - (-50) \text{ dB}$$
30. Record in the calculated results to the corresponding cells in the “Calculated ACLR Error” column of [Table A-96](#) and verify that it is within specification.
31. Calculate the ACLR Error at -5 MHz Offset and $+5$ MHz Offset by using the following formula:

$$\text{ACLR Error at } -5 \text{ or } 5 \text{ MHz Offset} = 10 \text{ LOG}_{10}(10^{(-45/10)} + 10^{(\text{Measured_ACLR}/10)}) - (-45) \text{ dB}$$
32. Record in the calculated results to the corresponding cells in the “Calculated ACLR Error” column of [Table A-96](#) and verify that it is within specification.

Error Vector Magnitude (EVM) Verification (Option 45 or Option 65)

The tests in this section can be used to verify the functionality of the WCDMA Demodulator or the HSDPA Demodulator (or both) of the WCDMA/HSDPA Signal Analyzer in the MS272xC Spectrum Master.

Procedure

1. Turn on the MG3700A Vector Signal Generator and the ML2438A power meter.
2. Connect the power sensor to the power meter and zero the sensor.
3. Connect the MG3700A, splitter, attenuator, power meter, and sensor as shown in [Figure 3-6](#).
4. Press the **On/Off** key to turn on the MS272xC, and wait until the measurement display appears. Then press the **Shift** key, and then press the **Mode** (9) key to activate the mode selection menu.
5. Use the **Up/Down** arrow keys to select WCDMA, and press the **Enter** key.
6. Press the **Shift** key, the **Preset** (1) key, and then the Preset submenu key.
7. On the MG3700A, press the **Preset** key (Yellow key on the upper-left corner).
8. Press the **Down Arrow** key to select Yes.
9. Press the **Set** key (Note that two Set keys are available, and they both do the same thing).
10. Press the (F1) submenu key to select “Load File to Memory”.
11. Press the (F1) submenu key again to select “Select Package”.
12. Using the **Down Arrow** key, step through the selection list until the WCDMA(BS Tx test) option is highlighted.
13. Press the **Set** key.
14. Press the (F6) submenu key, Return.
15. Press the **Set** key.
16. Using the **Down Arrow** key, step through the selection list until the TestModel_4_opt option is highlighted.

17. Press the **Set** key.
18. Press the **MOD On/Off** key and verify that the Modulation indicator on the display is On.
19. Press the **Frequency** key, then enter 1962.5, and press the **MHz** key.
20. Press the **Level** key, then enter -2, and press the **dBm** key.
21. Use the knob to adjust the power meter to read -20 dBm.
22. On the MS272xC, press the Center **Freq** main menu, enter 1962.5, and then press the MHz submenu key.
23. Press the **Measurements** main menu key, then press the Demodulator submenu key and press the Modulation Summary submenu key.
24. Press the **Setup** main menu key, then press the Auto Scrambling submenu key to turn it On.
25. Press the Max Spreading Factor submenu key to set it to 512.
26. Press the **Amplitude** main menu key, then press the Adjust Range submenu key.
27. Record the EVM reading into [Table A-97, “Option 45 or 65, WCDMA Error Vector Magnitude \(Test Model 4\)” on page A-44](#) and verify that it is within $\pm 2.5\%$.
28. This completes the EVM test for MS272xC with Option 45 and the first EVM test for MS272xC with Option 65.

For MS272xC with Option 65

1. On the MG3700A, press the **Preset** key (Yellow key on the upper-left corner).
2. Press the **Down Arrow** key to select Yes.
3. Press the **Set** key (Note that two Set keys are available, and they both do the same thing).
4. Press the (F1) submenu key to select “Load File to Memory”.
5. Press the (F1) submenu key again to select “Select Package”.
6. Using the **Down Arrow** key, step through the selection list until the WCDMA(BS Tx test) option is highlighted.
7. Press the **Set** key.
8. Press the (F6) submenu key, Return.
9. Press the **Set** key.
10. Using the **Down Arrow** key, step through the selection list until the TestModel_5_8HSPDSCH option is highlighted.
11. Press the **Set** key.
12. Press the **MOD On/Off** key and verify that the Modulation indicator on the display is On.
13. Press the **Frequency** key, then enter 1962.5, and press the **MHz** key.
14. Press the **Level** key, then enter -2, and press the **dBm** key.
15. Use the knob to adjust the power meter to read -20 dBm.
16. On the MS272xC, press the Center Freq submenu key, enter 1962.5, and then press the MHz submenu key.
17. Press the **Measurements** main menu key, then press the Demodulator submenu key, and press the Modulation Summary submenu key.
18. Press the **Setup** main menu key, then press the Auto Scrambling submenu key to turn it On.
19. Press the Max Spreading Factor submenu key to set it to 512.
20. Press the **Amplitude** main menu key, then press the Adjust Range submenu key.
21. Record the EVM reading into [Table A-98, “Option 65, HSDPA Error Vector Magnitude \(Test Model 5\)” on page A-44](#) and verify that it is within 2.5%.
22. This completes the two EVM tests for MS272xC with Option 65.

3-6 Option 46 and/or Option 47, Fixed WiMAX Signal Analyzer Verification

The tests in this section verify the functionality of the Fixed WiMAX Signal Analyzer of the MS272xC.

Fixed WiMAX Channel Power Accuracy Tests (Option 46)

Equipment Required for MS2722C, MS2723C and MS2724C

- Anritsu MG3700A Vector Signal Generator
- Frequency Reference Symmetricom Rubisource T&M
- Power Meter, Anritsu Model ML2438A
- Power Sensor, Anritsu Model MA2482D
- Power Splitter, Aeroflex/Weinschel Model 1870A
- Fixed Attenuator, Aeroflex/Weinschel Model 4410 (2)
- Anritsu 34NN50A 50 ohm Adapter (2)
- Anritsu 15NN50-1.5C RF Coaxial Cable
- BNC male to BNC male Coaxial Cable

Equipment Required for MS2725C and MS2726C

- All of the above
- Anritsu 71693-R Ruggedized K(f) to N(f) Adapter

Setup

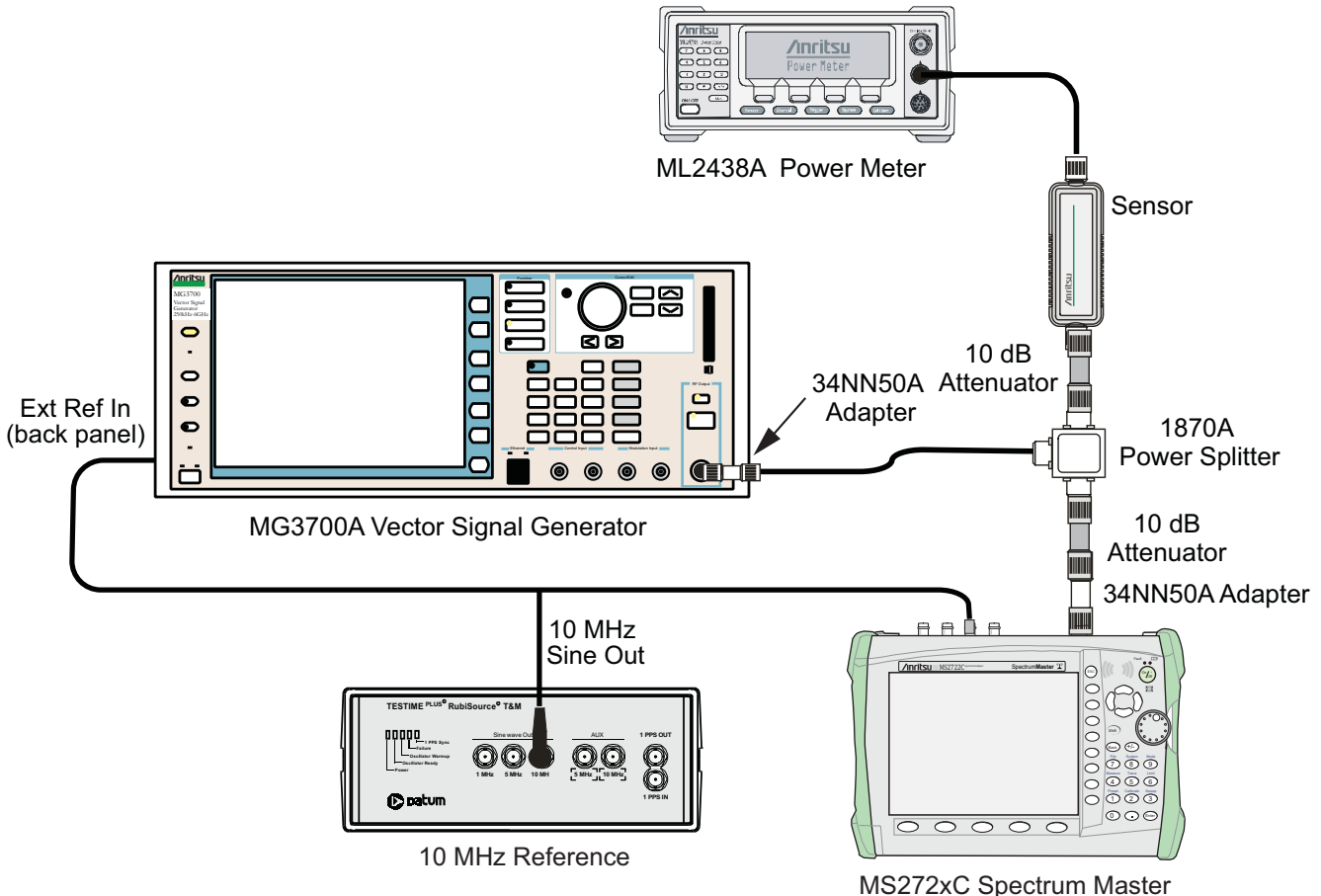

Figure 3-7. Fixed WiMAX Signal Analyzer, Test Setup

Procedure

1. Connect the Power Sensor to the power meter and zero the sensor.
2. Set the Power Meter Measurement MODE to “True RMS”, set Averaging MODE to “Moving”, and set Averaging NUMBER to “256”.
3. Set the calibration factor frequency of the power sensor to 2600.5 MHz.
4. Connect the Power Sensor, 1870A splitter, and 10 dB attenuators (quantity 2) as shown in [Figure 3-7](#).
5. Set the MG3700A as follows:
 - a. Press the yellow **Preset** button (answer yes to the question).
 - b. Press the **Set** key.
 - c. Press the (F1) submenu key to select “Load File to Memory”.
 - d. Press the (F1) submenu key again to select “Select Package”.
 - e. Using the **Down Arrow** key, step through the selection list until WiMAX is highlighted.
 - f. Press the **Set** key.
 - g. Press the (F6) submenu key, Return.
 - h. Press the **Set** key. The “Select Package” list box is displayed. Again select WiMAX and press **Set**.
 - i. Another file list is displayed. Select (highlight) Mx10g32.
 - j. Press the **Set** key.
 - k. Press the **MOD On/Off** key and verify that the LED is On. Ensure that the “Playing” indicator is displaying the moving pattern.
 - l. Press the **Frequency** key, then enter 2600.5 MHz.
 - m. Press the **Level** key, then enter 2 dBm. Turn the output On.
6. Adjust the MG3700A Level setting with the knob so that the power meter reads $-15.0 \text{ dBm} \pm 0.2 \text{ dB}$, and record the actual power meter reading into the “Input Power Reading” column of [Table A-99](#), “[Option 46, Fixed WiMAX Channel Power Accuracy Adjusted MG3700A Level Settings](#)” on page A-45.
7. Set the MS272xC to Fixed WiMAX Signal Analyzer mode and Preset the instrument.
8. Set the MS272xC as follows:
 - a. Press the **Freq** main menu and set the Center Freq to 2600.5 MHz.
 - b. Press the **Setup** main menu key and set the Bandwidth to 10 MHz.
 - c. Press the CP Ratio submenu key (under the **Setup** main menu key) and set the CP Ratio to 1/32.
 - d. Press the **Measurements** main menu key and press RF Measurements, then press Power vs. Time.
9. Record the MS272xC Channel Power (RSSI) reading into the “Measured Channel Power (RSSI)” column in [Table A-100](#), “[Option 46, Fixed WiMAX Channel Power Accuracy](#)” on page A-45.
10. Calculate the Channel Power Error by subtracting the MS272xC “Measured Channel Power (RSSI)” reading from the power meter reading in Step 6 ([Table A-99](#)). Record the result into the “Error” column in [Table A-100](#).
11. Verify that the error is within specification.
12. Adjust the MG3700A Level setting to approximately -33 dBm so that the power meter reads -50.0 dBm , and record the actual power meter reading into the “Input Power Reading” column of [Table A-99](#).
13. Record the MS272xC Channel Power (RSSI) reading into the “Measured Channel Power (RSSI)” column in [Table A-100](#).
14. Calculate the Channel Power Error by subtracting the MS272xC “Measured Channel Power (RSSI)” reading from the power meter reading in Step 12 ([Table A-99](#)). Record the result to the “Error” column in [Table A-100](#).

15. Verify that the error is within specification.
16. Set the calibration factor frequency of the power sensor to 3600.5 MHz.
17. Set MG3700A frequency to 3600.5 MHz.
18. Change the center frequency of the MS272xC to 3600.5 MHz.
19. Repeat Step 6 through Step 15 using the 3600.5 MHz setting.
20. Verify that the errors are within specification.
21. Set the calibration factor frequency of the power sensor to 5600.5 MHz.
22. Set MG3700A frequency to 5600.5 MHz.
23. Change the center frequency of the MS272xC to 5600.5 MHz.
24. Repeat Step 6 through Step 15 using the 5600.5 MHz setting.

Fixed WiMAX Residual EVM and Frequency Error Tests (Option 47)

Procedure

1. Connect the Power Sensor to the power meter and zero the sensor.
2. Set the Power Meter Measurement MODE to “True RMS”, set Averaging MODE to “Moving”, and set Averaging NUMBER to “256”.
3. Set the calibration factor frequency of the power sensor to 2600.5 MHz.
4. Connect the Power Sensor, 1870A splitter, and 10 dB attenuators as shown in [Figure 3-7](#).
5. Set the MG3700A as follows:
 - a. Press the yellow **Preset** button (answer yes to the question).
 - b. Press the **Set** key
 - c. Press the (F1) submenu key to select “Load File to Memory”.
 - d. Press the (F1) submenu key again to select “Select Package”.
 - e. Using the **Down Arrow** key, step through the selection list until WiMAX is highlighted.
 - f. Press the **Set** key.
 - g. Press the (F6) submenu key, Return.
 - h. Press the **Set** key. The “Select Package” list box is displayed. Again select WiMAX and press **Set**.
 - i. Another file list is displayed. Select (highlight) Mx10g32.
 - j. Press the **Set** key.
 - k. Press the **MOD On/Off** key and verify that the LED is On. Ensure that the “Playing” indicator is displaying the moving pattern.
 - l. Press the **Frequency** key, then enter 2600.5 MHz.
 - m. Press the **Level** key, then enter 2 dBm. Turn the output On.
6. Adjust the MG3700A Level setting with the knob so that the power meter reads $-15.0 \text{ dBm} \pm 0.2 \text{ dB}$.
7. Set the MS272xC to Fixed WiMAX Signal Analyzer mode and Preset the instrument.
8. Set the MS272xC as follows:
 - a. Press the **Freq** main menu key and set the Center Freq to 2600.5 MHz.
 - b. Press the **Setup** main menu key and set the Bandwidth to 10 MHz.
 - c. Press the CP Ratio submenu key (under the **Setup** main menu key) and set the CP Ratio to 1/32.
 - d. Press the **Measurements** main menu key, and press Demodulator, then press Modulation Summary.

9. Record the MS272xC EVM (rms) reading into the “EVM (rms)” column in [Table A-101, “Option 47, Fixed WiMAX Residual EVM” on page A-46.](#)
10. Verify that the measured EVM is within specification.
11. Adjust the MG3700A Level setting to approximately -33 dBm so that the power meter reads -50.0 dBm.
12. Record the MS272xC EVM (rms) reading into the “EVM (rms)” column in [Table A-101.](#)
13. Verify that the measured EVM is within specification.
14. Record the MS272xC Frequency Error reading into [Table A-102, “Option 47, Fixed WiMAX Frequency Error” on page A-46.](#)
15. Verify that the measured Frequency Error is within specification.
16. Set the calibration factor frequency of the power sensor to 3600.5 MHz.
17. Set MG3700A frequency to 3600.5 MHz.
18. Change the center frequency of MS272xC to 3600.5 MHz.
19. Measure the EVM (rms) for both -15 dBm and -50 dBm, and then record the measured results into [Table A-101.](#)
20. Verify that the measured EVM is within specification.
21. Set the calibration factor frequency of the power sensor to 5600.5 MHz.
22. Set MG3700A Frequency to 5600.5 MHz.
23. Adjust the MG3700A Level setting with the knob so that the power meter reads -15.0 dBm ± 0.2 dB.
24. Change the center frequency of the MS272xC to 5600.5 MHz.
25. Record the MS272xC EVM (rms) reading into the “EVM (rms)” column in [Table A-101.](#)
26. Verify that the measured EVM is within specification.
27. Adjust the MG3700A Level setting to approximately -33 dBm so that the power meter reads -50.0 dBm.
28. Record the MS272xC EVM (rms) reading into the “EVM (rms)” column in [Table A-101.](#)
29. Verify that the measured EVM is within specification.
30. Record the MS272xC Frequency Error reading into [Table A-102.](#)
31. Verify that the measured Frequency Error is within Specification.

3-7 Option 60 and/or Option 61, TDSCDMA Signal Analyzer Option Verification

The tests in this section verify the function of the optional TDSCDMA Signal Analyzer in Models MS272xC Spectrum Master. Option 60 is TDSCDMA RF measurements. Option 61 is TDSCDMA Demodulator measurements.

Equipment Required for MS2722C, MS2723C and MS2724C

- Anritsu MG3700A Vector Signal Generator
- Frequency Reference Symmetricom Rubisource T&M
- Power Meter, Anritsu Model ML2438A
- Power Sensor, Anritsu Model MA2482D
- Power Splitter, Aeroflex/Weinschel Model 1870A
- Fixed Attenuator, Aeroflex/Weinschel Model 4410 (2)
- Anritsu 34NN50A 50 ohm Adapter (2)
- Anritsu 15NN50-1.5C RF Coaxial Cable
- BNC male to BNC male Coaxial Cable

Equipment Required for MS2725C and MS2726C

- All of the above
- Anritsu 71693-R Ruggedized K(f) to N(f) Adapter

Setup

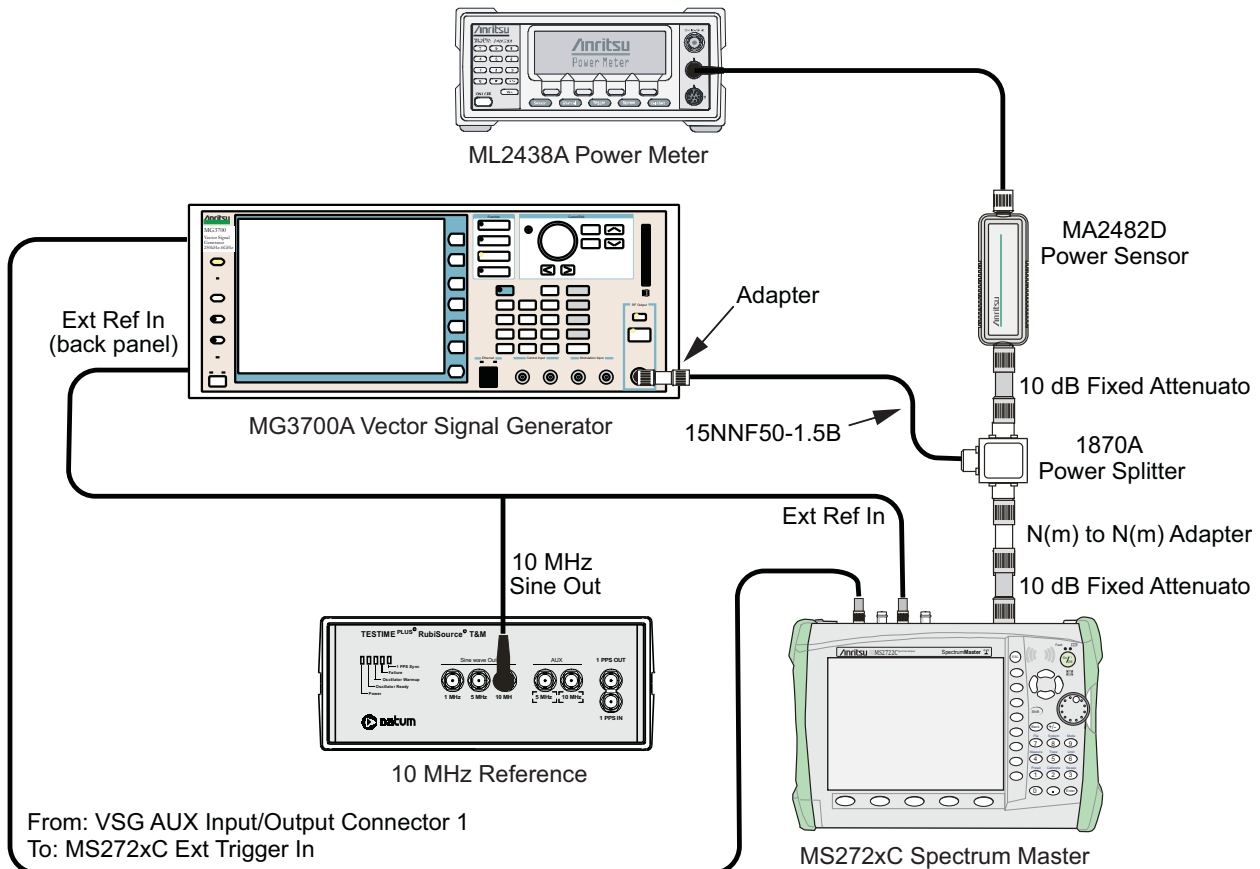

Figure 3-8. TDSCDMA Signal Analyzer Option Verification, Test Setup

Setup Procedure

1. Zero the power sensor prior to connecting to the power splitter.
2. Connect the equipment as shown in [Figure 3-8](#).
3. On the power meter, press the **Sensor** key, the Cal Factor submenu key, and then the Freq submenu key. Use the keypad to enter 2010 MHz as the input signal frequency, which sets the power meter to the proper power sensor calibration factor. Press the **System** key to display the power reading.
4. Set the power meter to Averaging, Moving, and 256 samples.
5. Set the MS272xC to TDSCDMA Signal Analyzer mode and Preset the instrument.

TDSCDMA Channel Power, Frequency Error, EVM, and Tau Test Procedure

Note	The TDSCDMA pattern requires a Waveform Data license (MX370001A) that must be purchased.
-------------	--

6. On the MG3700A, press the **Preset** key (yellow key on the upper-left corner).
7. Press the **Down Arrow** key or turn the knob to select **Yes**.
8. Press the **Set** key (Note that two Set keys are available, and they both do the same thing).
9. Press the (F1) submenu key to select “Load File to Memory”.
10. Press the (F1) submenu key again to select “Select Package”.
11. Press the **Down Arrow** key to step through the selection list until the TDSCDMA(MX370001A) option is highlighted.
12. Press the **Set** key.
13. Press the Return (F6) submenu key.
14. Press the **Set** key. The Select Package dialog box appears. Use the rotary knob to highlight TDSCDMA(MX370001A) and press the **Set** key to select.
15. Another file list appears. Use the rotary knob to select rmc-P-CCPCH_bs_dl and press the **Set** key to select.
16. Press the MOD On/Off key to turn the Modulation LED On and verify that the “Playing” indicator is flashing in the center of the LCD.
17. Press the **Frequency** key and enter 2010 MHz.
18. Press the **Level** key, enter -20 , and press the dBm key.
19. Adjust the MG3700A output so that the power meter reads $-45 \text{ dBm} \pm 0.5 \text{ dB}$, and record the actual reading into the “Power Meter Reading” row of [Table A-103](#), “[Option 60 or 61, TDSCDMA \(at 2010 MHz, \$-45 \text{ dBm Level}\$ \)](#)” on page A-46.
20. On the MS272xC, press the **Freq** main menu key, then press the Center Freq submenu key and enter 2010 MHz as center frequency.
21. Press the **Measurements** main menu key and press the TDSCDMA Summary submenu key (a red dot is displayed on the label).
22. Press the **Setup** hard key and press the Trigger submenu key. Then change Trigger Type to Ext by pressing the Trigger Type submenu key twice (or until Ext is underlined). Then wait 15 seconds to allow the MS272xC to update its measured results.
23. For an MS272xC with Option 60 (TDSCDMA RF Measurements), record the “Displayed Channel Power” into [Table A-103](#), then subtract the “Displayed Channel Power” value from the “Power Meter Reading” in Step 19. Then record the “Calculated Channel Power Error” into [Table A-103](#).
24. For an MS272xC with Option 61 (TDSCDMA Demodulator), record the Displayed Frequency Error, EVM and Tau into [Table A-103](#).
25. Verify that the measured values in Step 23 or Step 24 (or both) are within specifications.

3-8 Option 62 and/or Option 63, EVDO Signal Analyzer Option Verification

The tests in this section verify the optional EVDO Signal Analyzer functions in Model MS272xC Spectrum Master.

Equipment Required for MS2722C, MS2723C and MS2724C

- Anritsu MG3700A Vector Signal Generator
- Frequency Reference Symmetricom Rubisource T&M
- Power Meter, Anritsu Model ML2438A
- Power Sensor, Anritsu Model MA2482D
- Power Splitter, Aeroflex/Weinschel Model 1870A
- Anritsu 34NN50A 50 ohm Adapter (2)
- Anritsu 15NN50-1.5C RF Coaxial Cable
- BNC male to BNC male Coaxial Cable

Equipment Required for MS2725C and MS2726C

- All of the above
- Anritsu 71693-R Ruggedized K(f) to N(f) Adapter

Setup

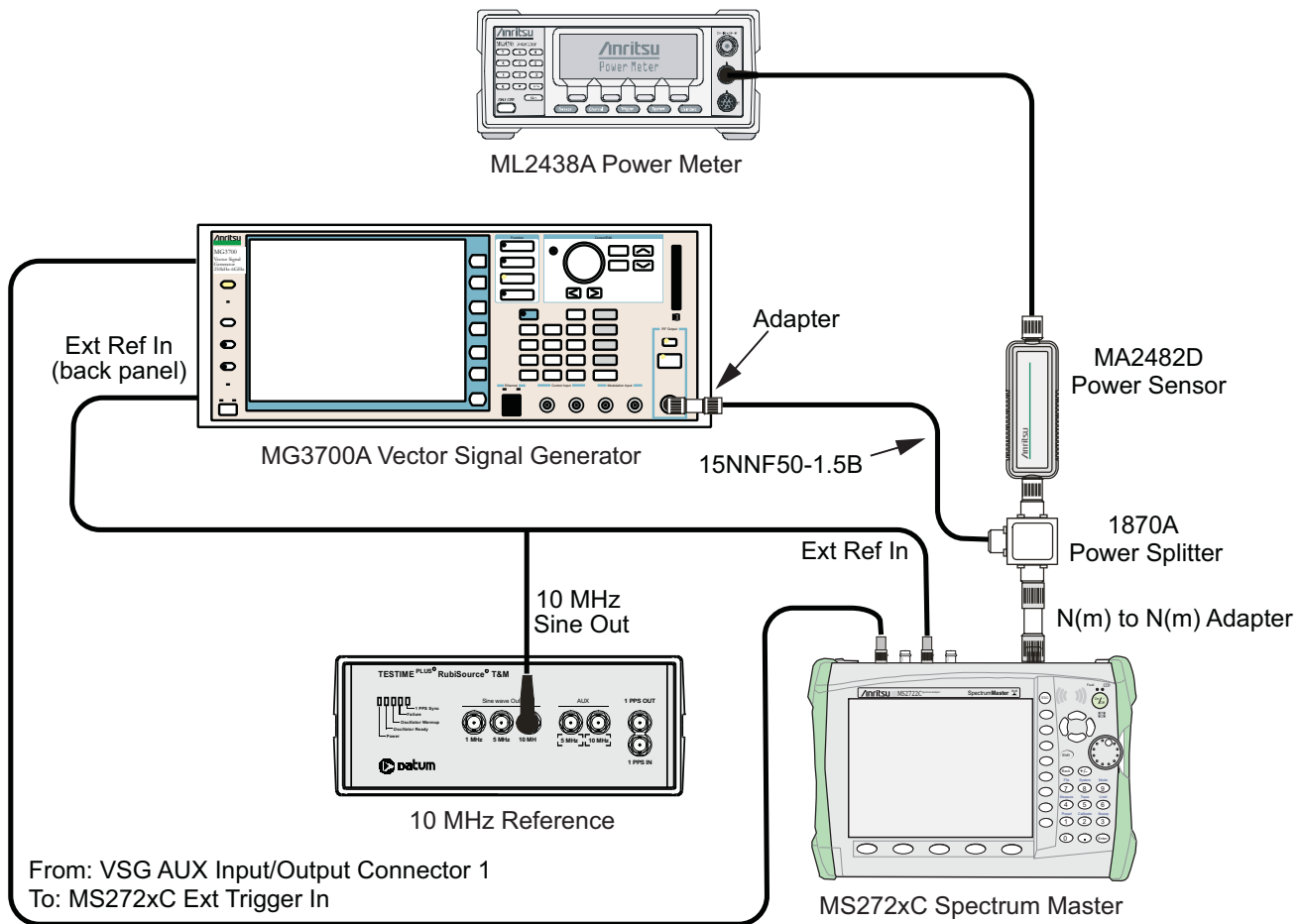

Figure 3-9. EVDO Signal Analyzer, Test Setup

Set up Procedure

1. Zero the power sensor prior to connecting to the power splitter.
2. Connect the equipment as shown in [Figure 3-9](#).
3. On the power meter, press the **Sensor** key, the Cal Factor submenu key, and then the Freq submenu key. Use the keypad to enter 870.03 MHz as the input signal frequency, which sets the power meter to the proper power sensor calibration factor. Press the **System** key to display the power reading.
4. Set the MS272xC mode to EVDO Signal Analyzer. Preset the instrument.

8PSK Modulation Channel Power, Frequency Error, Rho, and Tau Tests

Test Procedure

1. On the MG3700A, press the **Preset** key (Yellow key on the upper-left corner).
2. Press the **Down Arrow** key or turn the knob to select Yes.
3. Press the **Set** key (Note that two Set keys are available, and they both do the same thing).
4. Press the (F1) submenu key to select “Load File to Memory”.
5. Press the (F1) submenu key again to select “Select Package”.
6. Using the **Down Arrow** key, step through the selection list until the CDMA2000_1xEVDO option is highlighted.
7. Press the **Set** key.
8. Press the (F6) submenu key, Return.
9. Press the **Set** key. The Select Package box is displayed. Use the rotary knob to highlight CDMA2000_1xEVDO and press the **Set** key to select.
10. Another File List is displayed. Use the rotary knob to select FWD_921_6KBPS_2SLOT and press the **Set** key to select.
11. Press the **MOD On/Off** key to turn the Modulation LED On, and verify that the “Playing” indicator in the center of the LCD is flashing.
12. Press the **Frequency** key, and enter 870.03 MHz.
13. Press the **Level** key, enter -30, and press the **dBm** key.
14. Adjust the MG3700A output so that the power meter reads $-50 \text{ dBm} \pm 0.2 \text{ dB}$, and record the actual value as shown on the power meter into [Table A-104, “Option 62, At 870.03 MHz, -50 dBm Level, 921.6 kps 8PSK Modulation” on page A-47](#).
15. On the MS272xC, press the **Freq** main menu key, and enter 870.03 MHz as Center Freq.
16. Press the **Measurements** main menu key, and press EVDO Summary (a red dot is displayed on the label).
17. Press the **Setup** main menu key and press PN Setup. Then change PN Trigger to Ext by pressing the PN Trigger submenu key twice. Then wait 15 seconds to allow the MS272xC to update its measured results.
18. Record the “MS272xC Reading”, the displayed Channel Power value, into [Table A-104](#).
19. For MS272xC with Option 62 (EVDO RF Measurements), subtract the “MS272xC Reading” of displayed Channel Power value from the “Power Meter Reading” in Step 14. Then record the “Calculated Channel Power Error” into [Table A-104](#).
20. For MS272xC with Option 63 (EVDO Demodulator), record the displayed Freq Error, Rho Pilot and Tau into [Table A-109, “Option 63, At 870.03 MHz, -50 dBm Level, 921.6 kps 8PSK Modulation” on page A-48](#).
21. Verify that the measured values in Step 19 and Step 20 are within specifications.

QPSK Modulation Channel Power, Frequency Error, Rho, and Tau Tests

Test Procedure

1. Ensure that the equipment settings are unchanged from the previous test.
2. On the MG3700A, change the selected pattern to FWD_38_4KBPS_16SLOT.
3. On the power meter, press the **Sensor** key, the Cal Factor submenu key, and then the Freq submenu key. Use the keypad to enter 1930 MHz as the input signal frequency, which sets the power meter to the proper power sensor calibration factor. Press the **System** key to display the power reading.
4. Set the MG3700A Frequency to 1930.05 MHz.
5. Adjust the MG3700A output so that the power meter reads $0 \text{ dBm} \pm 0.2 \text{ dB}$, and record the actual value as shown on the power meter into [Table A-105, “Option 62, At 1930.05 MHz, 0 dBm Level, 38.4 kps QPSK Modulation” on page A-47.](#)
6. On the MS272xC, press the **Freq** main menu key and enter 1930.05 MHz as Center Freq. Then wait 15 seconds to allow the MS272xC to update its measured results.
7. Record the “MS272xC Reading”, the displayed Channel Power value, into [Table A-105.](#)
8. For MS272xC with Option 62 (EVDO RF Measurements), subtract the “MS272xC Reading” of displayed Channel Power value from the “Power Meter Reading” in Step 5. Then record the “Calculated Channel Power Error” into [Table A-105.](#)
9. For MS272xC with Option 63 (EVDO Demodulator), record the displayed Freq Error, Rho Pilot and Tau into [Table A-110, “Option 63, At 1930.05 MHz, 0 dBm Level, 38.4 kps QPSK Modulation” on page A-48.](#)
10. Verify that the measured values in Step 8 and Step 9 are within specifications.

16QAM Modulation Channel Power, Frequency Error, Rho, and Tau Tests

Test Procedure

1. Ensure that the equipment settings are unchanged from the previous test. The power sensor Cal Factor frequency should still be at 1930 MHz, and the MG3700A frequency and MS272xC Center Frequency should still be at 1930.05 MHz.
2. On the MG3700A, change the selected pattern to FWD_2457_6KBPS_1SLOT.
3. Adjust the MG3700A output so that the power meter reads $-50 \text{ dBm} \pm 0.2 \text{ dB}$, and record the actual value as shown on the power meter into [Table A-106, “Option 62, At 1930.05 MHz, -50 dBm Level, 2457.6 kps 16QAM Modulation” on page A-47.](#)
4. Then wait 15 seconds to allow the MS272xC to update its measured results.
5. Record the “MS272xC Reading”, the displayed Channel Power value, into [Table A-106.](#)
6. For MS272xC with Option 62 (EVDO RF Measurements), subtract the “MS272xC Reading” of displayed Channel Power value from the “Power Meter Reading” in Step 3. Then record the “Calculated Channel Power Error” into [Table A-106.](#)
7. For MS272xC with Option 63 (EVDO Demodulator), record the displayed Freq Error, Rho Pilot and Tau into [Table A-111, “Option 63, At 1930.05 MHz, -50 dBm Level, 2457.6 kps 16QAM Modulation” on page A-49.](#)
8. Verify that the measured values in Step 6 and Step 7 are within specifications.

Idle Slot Channel Power, Frequency Error, Rho, and Tau Tests

Test Procedure

1. Ensure that the equipment settings are unchanged from the previous test. The power sensor Cal Factor frequency should still be at 1930 MHz, and the MG3700A frequency and MS272xC Center Frequency should still be at 1930.05 MHz.
2. On the MG3700A, change the selected pattern to FWD_IDLE.
3. Adjust the MG3700A output so that the power meter reads $-50 \text{ dBm} \pm 0.2 \text{ dB}$, and record the actual value as shown on the power meter into [Table A-107, “Option 62, At 1930.05 MHz, \$-50 \text{ dBm}\$ Level, Idle Slot” on page A-47](#)
4. Then wait 15 seconds to allow the MS272xC to update its measured results.
5. Record the “MS272xC Reading”, the displayed Channel Power value, into [Table A-107](#).
6. For MS272xC with Option 62 (EVDO RF Measurements), subtract the “MS272xC Reading” of displayed Channel Power value from the “Power Meter Reading” in Step 3. Then record the “Calculated Channel Power Error” into [Table A-107](#).
7. For MS272xC with Option 63 (EVDO Demodulator), record the displayed Freq Error, Rho Pilot and Tau into [Table A-112, “Option 63, At 1930.05 MHz, \$-50 \text{ dBm}\$ Level, Idle Slot” on page A-49](#).
8. Verify that the measured values in Step 6 and Step 7 are within specifications.
9. On the power meter, press the **Sensor** key, the Cal Factor submenu key, and then the Freq submenu key. Use the keypad to enter 870.03 MHz as the input signal frequency, which sets the power meter to the proper power sensor calibration factor. Press the **System** key to display the power reading.
10. Set the MG3700A Frequency to 870.03 MHz.
11. Adjust the MG3700A output so that the power meter reads $-10 \text{ dBm} \pm 0.2 \text{ dB}$, and record the actual value as shown on the power meter into [Table A-108, “Option 62, At 870.03 MHz, \$-10 \text{ dBm}\$ Level, Idle Slot” on page A-48](#).
12. On the MS272xC, press the **Freq** main menu key, and enter 870.03 MHz as Center Freq. Then wait 15 seconds to allow the MS272xC to update its measured results.
13. Record the MS272xC displayed Channel Power value into [Table A-108](#).
14. For MS272xC with Option 62 (EVDO RF Measurements), subtract the “MS272xC Reading” of displayed Channel Power value from the “Power Meter Reading” in Step 11. Then record the “Calculated Channel Power Error” into [Table A-108](#).
15. For MS272xC with Option 63 (EVDO Demodulator), record the displayed Freq Error, Rho Pilot and Tau into [Table A-113, “Option 63, At 870.03 MHz, \$-10 \text{ dBm}\$ Level, Idle Slot” on page A-49](#).
16. Verify that the measured values in Step 14 and Step 15 are within specifications.

3-9 Option 66 and/or Option 67, Mobile WiMAX Signal Analyzer Verification

Mobile WiMAX Channel Power Accuracy Tests (Option 66)

The tests in this section verify the functionality of the Mobile WiMAX Signal Analyzer of the MS272xC Spectrum Master.

Equipment Required for MS2722C, MS2723C and MS2724C

- Anritsu MG3700A Vector Signal Generator
- Frequency Reference Symmetricom Rubisource T&M
- Power Meter, Anritsu Model ML2438A
- Power Sensor, Anritsu Model MA2482D
- Power Splitter, Aeroflex/Weinschel Model 1870A
- Fixed Attenuator, Aeroflex/Weinschel Model 4410 (2)
- Anritsu 34NN50A 50 ohm Adapter (2)
- Anritsu 15NN50-1.5C RF Coaxial Cable
- BNC male to BNC male Coaxial Cable

Equipment Required for MS2725C and MS2726C

- All of the above
- Anritsu 71693-R Ruggedized K(f) to N(f) Adapter

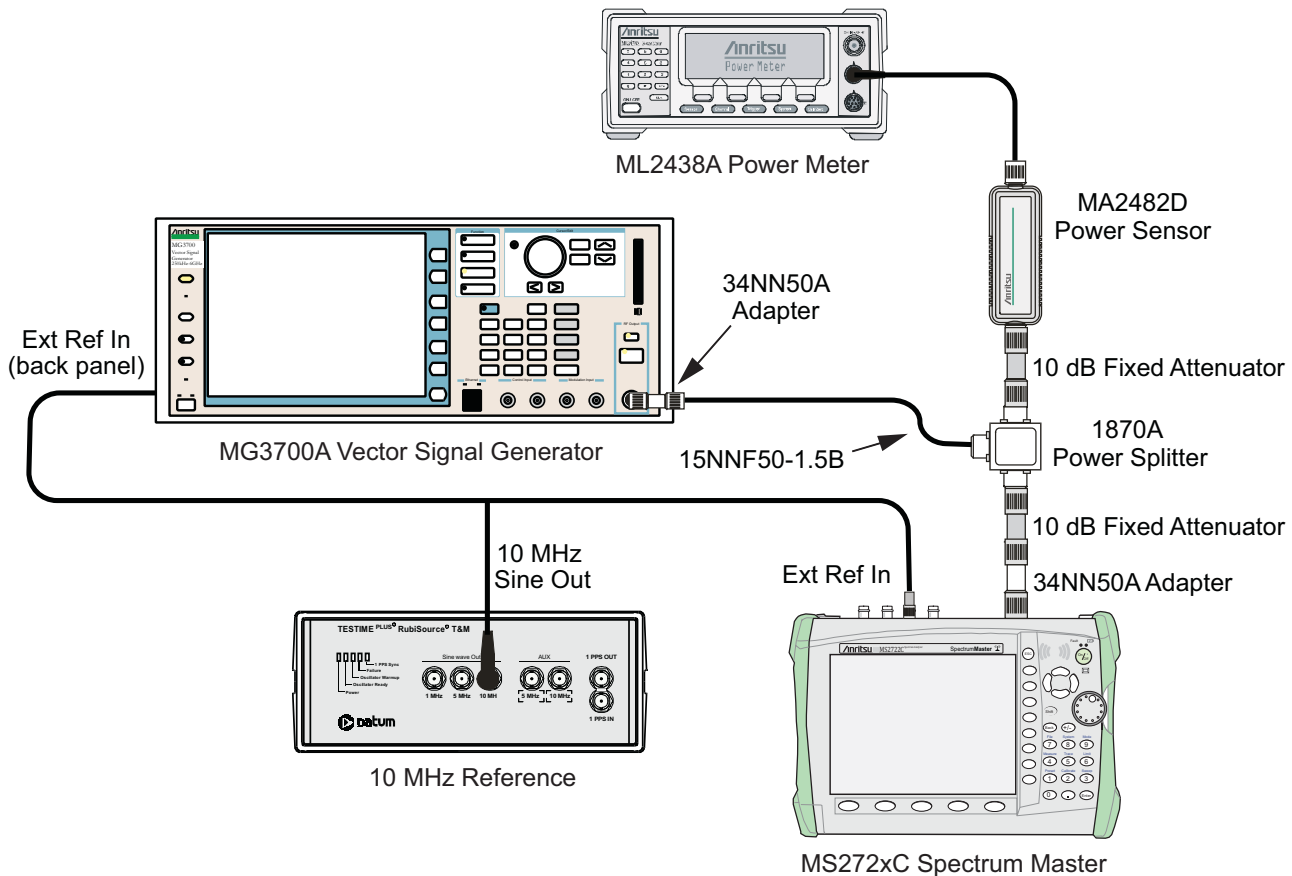

Figure 3-10. Mobile WiMAX Channel Power Accuracy Test Setup

Setup

1. Connect the Power Sensor to the power meter and zero the sensor.
2. Set the Power Meter Measurement MODE to True RMS, set Averaging MODE to Moving, and set Averaging NUMBER to **256**.
3. Set the calibration factor frequency of the power sensor to 2600.5 MHz.
4. Connect all of the test equipment as shown in [Figure 3-10](#).

Channel Power Accuracy (10 MHz Bandwidth and 10 ms Frame Length)

Procedure

1. Set the MG3700A as follows:
 - a. Press the yellow **Preset** button (answer yes to the question).
 - b. Press the **Set** key
 - c. Press the (F1) submenu key to select “Load File to Memory”.
 - d. Press the (F1) submenu key again to select “Select Package”.
 - e. Using the **Down Arrow** key, step through the selection list until mWiMAX is highlighted.
 - f. Press the **Set** key.
 - g. Press the (F6) submenu key, Return.
 - h. Press the **Set** key. The “Select Package” list box is displayed. Again select mWiMAX and press **Set**.
 - i. Another file list is displayed. Select (highlight) “10m1024g8_0_10_cap”.
 - j. Press the **Set** key.
 - k. Press the **MOD On/Off** key and verify that the LED is On. Ensure that the “Playing” indicator is displaying the moving pattern.
 - l. Press the **Frequency** key, then enter 2600.5 MHz.
 - m. Press the **Level** key, then enter 2 dBm. Turn the output On.
2. Adjust the MG3700A Level setting with the knob so that the power meter reads $-15.0 \text{ dBm} \pm 0.2 \text{ dB}$, and record the actual value as shown on the power meter into [Table A-114, “Option 66, Mobile WiMAX Channel Power Accuracy Power Error \(2600.5 MHz and \$-15.0 \text{ dBm}\$ \)”](#) on page A-50.
3. Set the MS272xC to Mobile WiMAX Signal Analyzer mode and Preset the instrument.
4. Set the MS272xC as follows:
 - a. Press the **Freq** main menu key and set the Center Freq to 2600.5 MHz.
 - b. Press the **Setup** main menu key and set the Bandwidth to 10 MHz.
 - c. Press the Frame Length submenu key and set the Frame Length to 10 ms.
 - d. Press the **Measurements** main menu key, press RF, and then press Power vs. Time.
5. Record the “MS272xC Reading”, the displayed Channel Power (RSSI) value, into [Table A-114](#).
6. Calculate the Channel Power Error by subtracting the “MS272xC reading” from the “Power Meter Reading” in Step 2. Record the result into [Table A-114](#).
7. Verify that the error is within specification.
8. Adjust the MG3700A Level setting to approximately -33 dBm so that the power meter reads $-50.0 \text{ dBm} \pm 0.2 \text{ dB}$, and record the actual value as shown on the power meter into [Table A-115, “Option 66, Mobile WiMAX Channel Power Accuracy Power Error \(2600.5 MHz and \$-50.0 \text{ dBm}\$ \)”](#) on page A-50.

9. Record the “MS272xC Reading”, the displayed Channel Power (RSSI) value, into [Table A-115](#).
10. Calculate the Channel Power Error by subtracting the “MS272xC Reading” of Channel Power (RSSI) from the “Power Meter Reading” in Step 8. Record the “Calculated Channel Power Error” into [Table A-115](#).
11. Verify that the error is within specification.
12. Set the calibration factor frequency of the power sensor to 3600.5 MHz.
13. Set MG3700A Frequency to 3600.5 MHz.
14. Change the center frequency of MS272xC to 3600.5 MHz.
15. Measure the Channel Power (RSSI) for both -15 dBm and -50 dBm, and then record the measured results and calculated errors into [Table A-116](#), “Option 66, Mobile WiMAX Channel Power Accuracy Power Error (3600.5 MHz and -15.0 dBm)” on page A-50 and [Table A-117](#), “Option 66, Mobile WiMAX Channel Power Accuracy Power Error (3600.5 MHz and -50.0 dBm)” on page A-50.
16. Verify that the errors are within specification.

Channel Power Accuracy (5 MHz Bandwidth and 5 ms Frame Length)

Procedure

1. Set the MG3700A as follows:
 - a. Press the yellow **Preset** button (answer yes to the question).
 - b. Press the **Set** key
 - c. Press the (F1) submenu key to select “Load File to Memory”.
 - d. Press the (F1) submenu key again to select “Select Package”.
 - e. Using the **Down Arrow** key, step through the selection list until “mWiMAX” is highlighted.
 - f. Press the **Set** key.
 - g. Press the (F6) submenu key, Return.
 - h. Press the **Set** key. The “Select Package” list box is displayed. Again select mWiMAX and press **Set**.
 - i. Another file list is displayed. Select (highlight) 5m512g8_2_5_cap.
 - j. Press the **Set** key.
 - k. Press the **MOD On/Off** key and verify that the LED is On. Ensure that the “Playing” indicator is displaying the moving pattern.
 - l. Press the **Frequency** key, then enter 2600.5 MHz.
 - m. Press the **Level** key, then enter 2 dBm. Turn the output On.
2. Adjust the MG3700A Level setting with the knob so that the power meter reads -15.0 dBm \pm 0.2 dB, and record the actual value as shown on the power meter into [Table A-118](#), “Option 66, Mobile WiMAX Channel Power Accuracy Power Error (2600.5 MHz and -15.0 dBm)” on page A-51.
3. Set the MS272xC to Mobile WiMAX Signal Analyzer mode and preset the instrument.
4. Set the MS272xC as follows:
 - a. Press the **Freq** main menu key and set the Center Freq to 2600.5 MHz.
 - b. Press the **Setup** main menu key and set the Bandwidth to 5 MHz.
 - c. Press the Frame Length submenu key and set the Frame Length to 5 ms.
 - d. Press the **Measurements** main menu key, press RF, then press Power vs. Time.

5. Record the “MS272xC Reading”, the displayed Channel Power (RSSI) value, into [Table A-118](#).
6. Calculate the Channel Power Error by subtracting the “MS272xC reading” from the “Power Meter Reading” in Step 2. Record the result into [Table A-118](#).
7. Verify that the error is within specification.
8. Adjust the MG3700A Level setting to approximately -33 dBm so that the power meter reads -50.0 dBm \pm 0.2 dB, and record the actual value as shown on the power meter into [Table A-119](#), “[Option 66, Mobile WiMAX Channel Power Accuracy Power Error \(2600.5 MHz and \$-50.0\$ dBm\)](#)” on page A-51.
9. Record the “MS272xC Reading”, the displayed Channel Power (RSSI) value, into [Table A-119](#).
10. Calculate the Channel Power Error by subtracting the “MS272xC Reading” of Channel Power (RSSI) from the “Power Meter Reading” in Step 8. Record the “Calculated Channel Power Error” into [Table A-119](#).
11. Verify that the error is within specification.
12. Set the calibration factor frequency of the power sensor to 3600.5 MHz.
13. Set MG3700A Frequency to 3600.5 MHz.
14. Change the Center Frequency of MS272xC to 3600.5 MHz.
15. Measure the Channel Power (RSSI) for both -15 dBm and -50 dBm, and then record the measured results and calculated errors into [Table A-120](#), “[Option 66, Mobile WiMAX Channel Power Accuracy Power Error \(3600.5 MHz and \$-15.0\$ dBm\)](#)” on page A-51 and [Table A-121](#), “[Option 66, Mobile WiMAX Channel Power Accuracy Power Error \(3600.5 MHz and \$-50.0\$ dBm\)](#)” on page A-51.
16. Verify that the errors are within specification.

Mobile WiMAX Residual EVM and Frequency Error Tests (Option 67)

Equipment Required for MS2722C, MS2723C and MS2724C

- Anritsu MG3700A Vector Signal Generator
- Frequency Reference Symmetricom Rubisource T&M
- Anritsu 34NN50A 50 ohm Adapter (2)
- Anritsu 15NN50-1.5C RF Coaxial Cable
- BNC male to BNC male Coaxial Cable

Equipment Required for MS2725C and MS2726C

- All of the above
- Anritsu 71693-R Ruggedized K(f) to N(f) Adapter

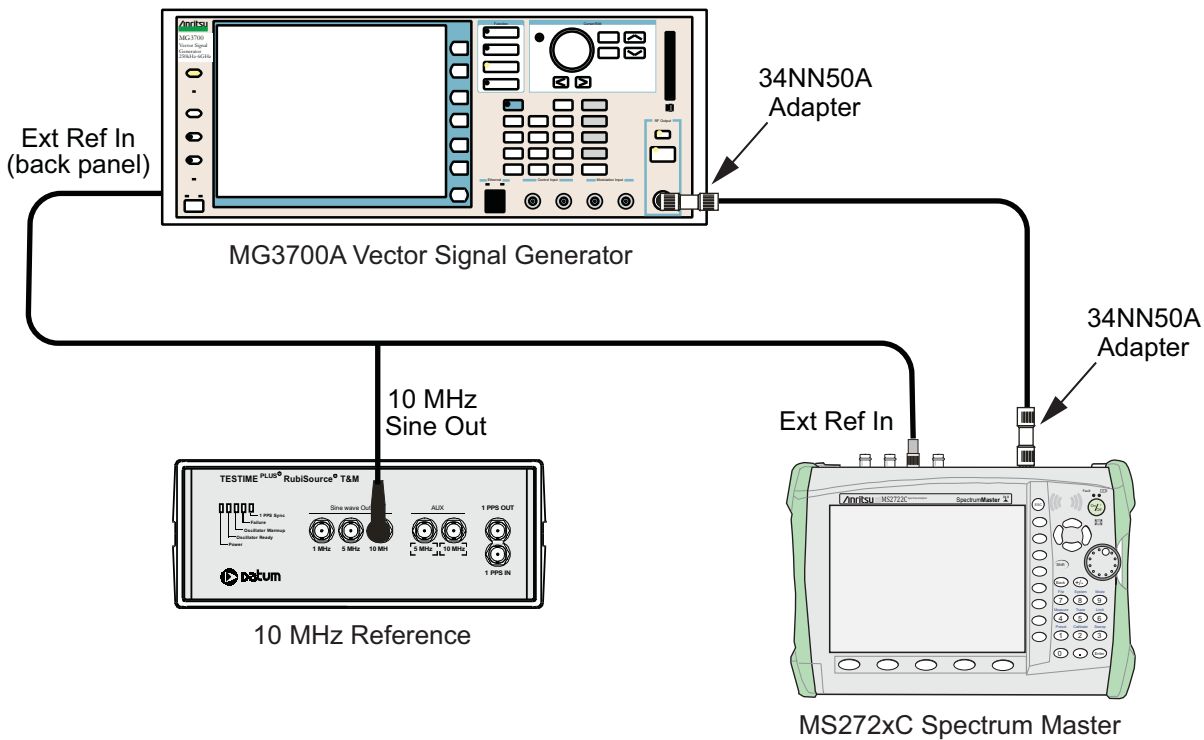

Figure 3-11. Mobile WiMAX Residual EVM Test Setup

Setup Procedure

1. Connect the 10 MHz Reference to the 10 MHz/5 MHz Ref Input of the MG3700A and the Ext Ref In of the MS272xC as shown in [Figure 3-11](#).
2. Connect the RF Out of the MG3700A to the Spectrum Analyzer RF In connector of the MS272xC.

Residual EVM and Frequency Error (10 MHz Bandwidth and 10 ms Frame Length)

3. Set the MG3700A as follows:
 - a. Press the yellow **Preset** button (answer yes to the question).
 - b. Press the **Set** key
 - c. Press the (F1) submenu key to select “Load File to Memory”.
 - d. Press the (F1) submenu key again to select “Select Package”.
 - e. Using the **Down Arrow** key, step through the selection list until mWiMAX is highlighted.
 - f. Press the **Set** key.
 - g. Press the (F6) submenu key, Return.
 - h. Press the **Set** key. The “Select Package” list box is displayed. Again select mWiMAX and press **Set**.
 - i. Another file list is displayed. Select (highlight) 10m1024g8_0_10_cap.
 - j. Press the **Set** key.
 - k. Press the **MOD On/Off** key and verify that the LED is On. Ensure that the “Playing” indicator is displaying the moving pattern.
 - l. Press the **Frequency** key, then enter 2600.5 MHz.
 - m. Press the **Level** key, then enter –15 dBm. Turn the output On.
4. Set the MS272xC to Mobile WiMAX Signal Analyzer mode and Preset the instrument.
5. Set the MS272xC as follows:
 - a. Press the **Freq** main menu key and set the Center Freq to 2600.5 MHz.
 - b. Press the **Setup** main menu key and set the Bandwidth to 10 MHz.
 - c. Press the CP Ratio submenu key (under the **Setup** main menu key) and set the CP Ratio to 1/8.
 - d. Press the Frame Length submenu key and set the Frame Length to 10 ms.
 - e. Press the Demod submenu key and set Demod to FCH.
 - f. Press the **Measurements** main menu key and press Demodulator, then press Modulation Summary.
6. Record the MS272xC EVM (rms) reading into the “EVM (rms)” column in [Table A-122, “Option 67, Mobile WiMAX Residual EVM \(10 MHz Bandwidth and 10 ms Frame Length\)”](#) on page A-52.
7. Verify that the measured EVM is within specification.
8. Set the MG3700A Level to –50.0 dBm.
9. Record the MS272xC EVM (rms) reading into the “EVM (rms)” column in [Table A-122](#).
10. Verify that the measured EVM is within specification.
11. On the MS272xC, press the **Setup** main menu key, and set Demod to Auto.
12. Record the MS272xC frequency error reading to the “Frequency Error” column in [Table A-123, “Option 67, Mobile WiMAX Frequency Error \(10 MHz Bandwidth and 10 ms Frame Length\)”](#) on page A-52.
13. Verify that the measured Frequency Error is within specification.
14. Set MG3700A Frequency to 3600.5 MHz.
15. On the MS272xC, change the Center Frequency to 3600.5 MHz.
16. Press the **Setup** main menu key and set Demod to FCH.
17. Measure the EVM(rms) for both –15 dBm and –50 dBm, and then record the measured results into [Table A-122](#).
18. Verify that the measured EVM is within specification.
19. Repeat Step 11 through 13 to measure the Frequency Error at 3600.5 MHz.

Residual EVM and Frequency Error (5 MHz Bandwidth and 5 ms Frame Length)

20. Set the MG3700A as follows:

- a. Press the yellow **Preset** button (answer yes to the question).
- b. Press the **Set** key
- c. Press the (F1) submenu key to select “Load File to Memory”.
- d. Press the (F1) submenu key again to select “Select Package”.
- e. Using the **Down Arrow** key, step through the selection list until “mWiMAX” is highlighted.
- f. Press the **Set** key.
- g. Press the (F6) submenu key, **Return**.
- h. Press the **Set** key. The “Select Package” list box is displayed. Again select mWiMAX and press **Set**.
- i. Another file list is displayed. Select (highlight) 5m512g8_2_5_cap.
- j. Press the **Set** key.
- k. Press the **MOD On/Off** key and verify that the LED is On. Ensure that the “Playing” indicator is displaying the moving pattern.
- l. Press the **Frequency** key, then enter 2600.5 MHz.
- m. Press the **Level** key, then enter –15 dBm. Turn the output On.

21. Set the MS272xC as follows:

- a. Press the **Freq** main menu key and set the Center Freq to 2600.5 MHz.
- b. Press the **Setup** main menu key and set the Bandwidth to 5 MHz.
- c. Press the CP Ratio submenu key (under the **Setup** main menu key) and set the CP Ratio to 1/8.
- d. Press the Frame Length submenu key and set the Frame Length to 5 ms.
- e. Press the Demod submenu key and set Demod to FCH.
- f. Press the **Measurements** main menu key, press Demodulator, then press Modulation Summary.

22. Repeat Step 6 through Step 19, recording the results into [Table A-124, “Option 67, Mobile WiMAX Residual EVM \(5 MHz Bandwidth and 5 ms Frame Length\)”](#) on page A-52 and [Table A-125, “Option 67, Mobile WiMAX Frequency Error \(5 MHz Bandwidth and 5 ms Frame Length\)”](#) on page A-52.

3-10 LTE Signal Analyzer Option 541 and/or 542 and/or 543 Verification

The tests in this section verify the functionality of the LTE Signal Analyzer of the MS272xC Spectrum Master. There are tests for LTE Channel Power Accuracy Tests (Option 541 and 543) and LTE Residual EVM and Frequency Error Tests (Option 542 and 543)

Equipment Required for MS2722C, MS2723C and MS2724C

- Anritsu MG3700A Vector Signal Generator
- Frequency Reference Symmetricom Rubisource T&M
- Power Meter, Anritsu Model ML2438A
- Power Sensor, Anritsu Model MA2482D
- Power Splitter, Aeroflex/Weinschel Model 1870A
- Fixed Attenuator, Aeroflex/Weinschel Model 4410 (2)
- Anritsu 34NN50A 50 ohm Adapter (2)
- Anritsu 15NN50-1.5C RF Coaxial Cable
- BNC male to BNC male Coaxial Cable

Equipment Required for MS2725C and MS2726C

- All of the above
- Anritsu 71693-R Ruggedized K(f) to N(f) Adapter

Setup

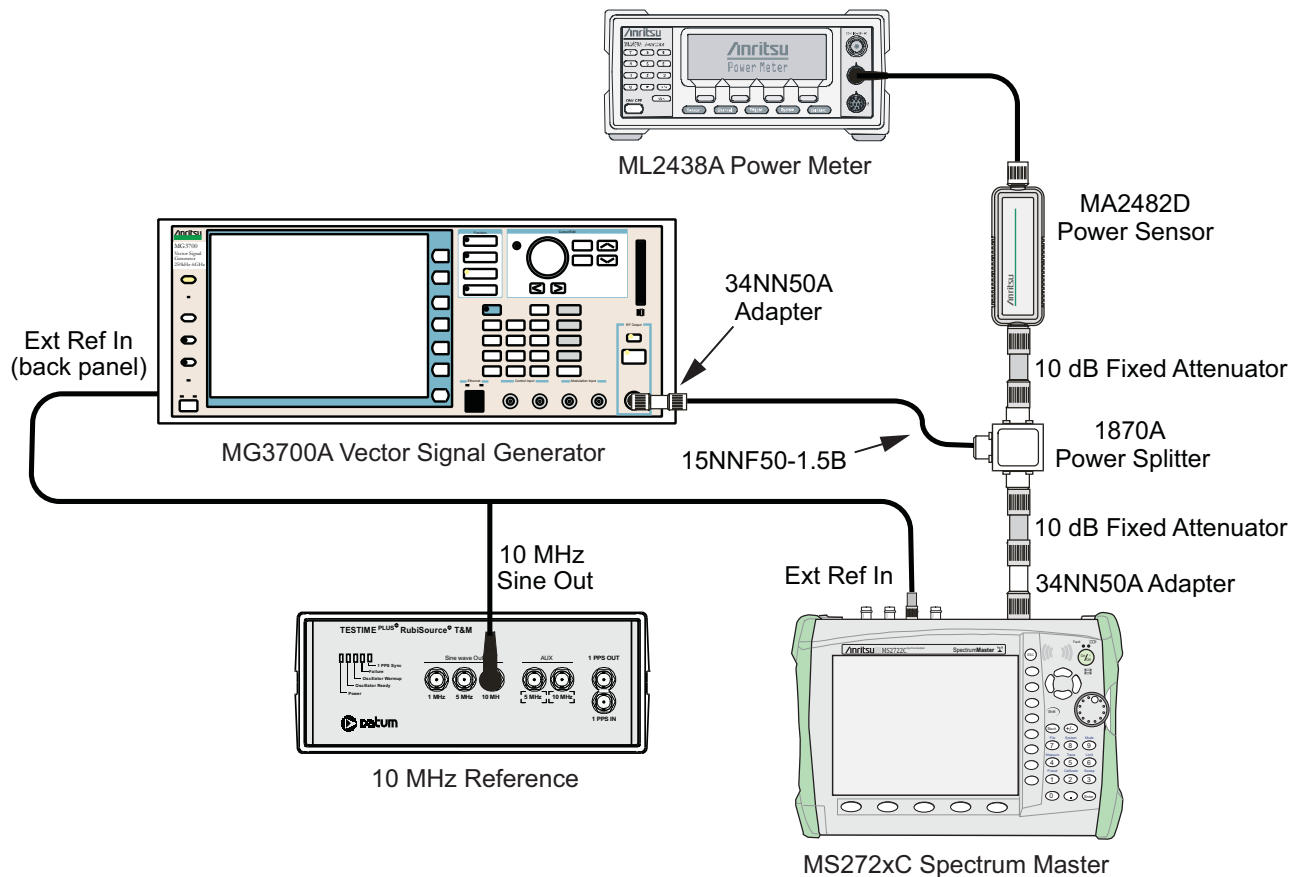

Figure 3-12. LTE Signal Analyzer Option Verification

LTE Channel Power Accuracy Tests (Option 541 and 543)

The tests in this section verify the function of the optional LTE Signal Analyzer in Model MS272xC.

Procedure

1. Connect the Power Sensor to the power meter and zero the sensor.
2. Set the Power Meter Measurement MODE to True RMS, set Averaging MODE to Moving, and set Averaging NUMBER to 256.
3. Set the calibration factor frequency of the power sensor to 750 MHz.
4. Connect the Power Sensor, 1870A splitter, 10 dB attenuators (quantity 2), as shown in [Figure 3-12](#).

Note The LTE pattern requires a Waveform Data license MX370108A that must be purchased.

5. Set the MG3700A as follows:
 - a. Press the yellow **Preset** button (answer yes to the question).
 - b. Press the **Set** key. Note: Both **Set** keys on the MG3700A perform the same function.
 - c. Press the (F1) submenu key to select “Load File to Memory”
 - d. Press the (F1) submenu key again to select “Select Package”
 - e. Using the Down Arrow key step through the selection list until LTE_DL_E-TM is highlighted.
 - f. Press the **Set** key.
 - g. Press the (F6) submenu key “Return”
 - h. Press the **Set** key. The “Select Package” list box will appear. Again select LTE_DL_E-TM and then the **Set** key.
 - i. Another file list will appear. Select (highlight) E-TM_1-1_10M.
 - j. Press the **Set** key.
 - k. Press the MOD On/Off key and verify that the LED is on. Ensure that the “Playing” indicator is displaying the moving pattern.
 - l. Press the **Frequency** key, then enter 750 MHz.
 - m. Press the **Level** key, then enter 2 dBm.
 - n. Turn the output on.
6. Adjust the MG3700A Level setting with the knob so that the power meter reads $-10.0 \text{ dBm} \pm 0.5 \text{ dB}$.
7. Set the MS272xC to LTE Signal Analyzer mode and Preset the unit.
8. Set the MS272xC as follows:
 - a. Press the **Freq** main menu key and set the Center Freq to 750 MHz.
 - b. Press the **Measurements** main menu key and select RF, then select Channel Spectrum.
9. Record the MS272xC Channel Power reading into the column labeled “Measured Channel Power” (row labeled 750 MHz, -10 dBm) in [Table A-126, “Option 541 and 543, LTE Channel Power Accuracy on page A-53](#).
10. Calculate the Channel Power Error by subtracting the MS272xC “Channel Power” reading from the power meter reading in Step 6. Record the result into the test record in the column labeled “Error” (row labeled 750 MHz, -10 dBm) in [Table A-126](#).
11. Verify that the error is within specification.
12. Adjust the MG3700A Level setting to approximately -33 dBm so that the power meter reads $-50.0 \text{ dBm} \pm 0.5 \text{ dB}$.

13. Record the MS272xC Channel Power reading into the test record in the column labeled “Measured Channel Power” (row labeled 750 MHz, –50 dBm) in [Table A-126](#).
14. Calculate the Channel Power Error by subtracting the MS272xC “Channel Power” reading from the power meter reading that was recorded in Step 12. Record the result into the test record in the column labeled “Error” (row labeled 750 MHz, –50 dBm) in [Table A-126](#).
15. Verify that the error is within specification.
16. Set the calibration factor frequency of the power sensor to 2150 MHz.
17. Set MG3700A Frequency to 2150 MHz. Press the **Set** key.
18. Change the Center Frequency of the MS272xC to 2150 MHz.
19. Measure the Channel Power for –10 dBm and –50 dBm and then record the measured result and the calculated error into the test record in the column labeled “Measured Channel Power” and in the column labeled “Error” (rows labeled 2150 MHz) in [Table A-126](#).
20. For units with option 543, press the **Setup** main menu key and set the BW to 20 MHz then repeat Step 5a through Step 19 using the E-TM_1-1_20M pattern for Step 5i.

LTE Residual EVM and Frequency Error Tests (Option 542 and 543)

The tests in this section verify the function of the optional LTE Signal Analyzer in Model MS272xC Spectrum Master.

Procedure

1. Connect the Power Sensor to the power meter and zero the sensor.
2. Set the Power Meter Measurement MODE to True RMS, set Averaging MODE to Moving, and set Averaging NUMBER to 256.
3. Set the calibration factor frequency of the power sensor to 750 MHz.
4. Connect the Power Sensor, 1870A splitter, 10 dB attenuators (quantity 2), as shown in [Figure 3-12](#).

Note The LTE pattern requires a Waveform Data license MX370108A that must be purchased.
--

5. Set the MG3700A as follows:
 - a. Press the yellow Preset button (answer yes to the question).
 - b. Press the **Set** key. Note: Both **Set** keys on the MG3700A perform the same function.
 - c. Press the (F1) submenu key to select “Load File to Memory”
 - d. Press the (F1) submenu key again to select “Select Package”
 - e. Using the **Down Arrow** key step through the selection list until LTE_DL_E-TM is highlighted.
 - f. Press the **Set** key.
 - g. Press the (F6) submenu key “Return”
 - h. Press the **Set** key. The “Select Package” list box will appear. Again select LTE_DL_E-TM and **Set**.
 - i. Another file list will appear. Select (highlight) E-TM_3-1_10M.
 - j. Press the **Set** key.
 - k. Press the **MOD On/Off** key and verify that the LED is On. Ensure that the “Playing” indicator is displaying the moving pattern.
 - l. Press the **Frequency** key, then enter 750 MHz.
 - m. Press the Level key, then enter 2 dBm.
 - n. Turn the output On.

6. Adjust the MG3700A Level setting with the knob so that the power meter reads $-10.0 \text{ dBm} \pm 0.5 \text{ dB}$.
7. Set the MS272xC to LTE Signal Analyzer mode and Preset the unit.
8. Set the MS272xC as follows:
 - a. Press the **Freq** main menu key and set the Center Freq to 750 MHz.
 - b. Press the **Measurements** main menu key and select Modulation.
 - c. Press the Constellation submenu key.
9. Record the MS272xC Residual EVM(rms) and Frequency Error reading into the section “750 MHz, -10 dBm ” in [Table A-127](#), “Option 542, LTE Residual EVM and Frequency Accuracy” on page A-54.
10. Verify that the values are within specification.
11. Adjust the MG3700A Level setting to approximately -33 dBm so that the power meter reads $-50.0 \text{ dBm} \pm 0.5 \text{ dB}$.
12. Record the MS272xC Residual EVM(rms) and Frequency Error reading into the section “750 MHz, -50 dBm ” in [Table A-127](#).
13. Verify that the values are within specification.
14. Set the calibration factor frequency of the power sensor to 2150 MHz.
15. Set MG3700A Frequency to 2150 MHz. Press the **Set** key.
16. Adjust the MG3700A Level setting with the knob so that the power meter reads $-10.0 \text{ dBm} \pm 0.5 \text{ dB}$.
17. Change the Center Frequency of the MS272xC to 2150 MHz.
18. Record the MS272xC Residual EVM and Frequency Error reading into the section “2150 MHz, -10 dBm ” in [Table A-127](#).
19. Verify that the values are within specification.
20. Adjust the MG3700A Level setting to approximately -33 dBm so that the power meter reads $-50.0 \text{ dBm} \pm 0.5 \text{ dB}$.
21. Record the MS272xC Residual EVM and Frequency Error reading into the section “2150 MHz, -50 dBm ” in [Table A-127](#).
22. Verify that the values are within specification.
23. For units with option 543, press the **Setup** main menu key and set the BW to 20 MHz then repeat Step 5a through Step 22 using the E-TM_3-1_20M pattern for Step 5i.

Chapter 4 — Battery Information

4-1 General Information

The following information relates to the care and handling of the Anritsu 633-44 battery pack and Lithium-Ion batteries.

- The battery supplied with the Spectrum Master may need charging before use. Before using the Spectrum Master, the internal battery may be charged either in the unit using the AC-DC Adapter (40-168-R) or the 12-Volt DC adapter (806-62), or separately in the optional Dual Battery Charger (2000-1374).
- Use only Anritsu approved battery packs.
- Recharge the battery only in the Spectrum Master or in an Anritsu approved charger.
- When the Spectrum Master or the charger is not in use, disconnect it from the power source.
- Do not charge batteries for longer than 24 hours; overcharging may shorten battery life.
- If left unused a fully charged battery will discharge itself over time.
- Temperature extremes affect the ability of the battery to charge: allow the battery to cool down or warm up as necessary before use or charging.
- Discharge the battery from time to time to improve battery performance and battery life.
- The battery can be charged and discharged hundreds of times, but it will eventually wear out.
- The battery may need to be replaced when the operating time between charging becomes noticeably shorter than normal.
- Never use a damaged or worn out charger or battery.
- Storing the battery in extreme hot or cold places will reduce the capacity and lifetime of the battery.
- Never short-circuit the battery terminals.
- Do not drop, mutilate or attempt to disassemble the battery.
- Do not dispose of batteries in a fire!
- Batteries must be recycled or disposed of properly. Do not place batteries in household garbage.
- Always use the battery for its intended purpose only.

4-2 Battery Pack Removal and Replacement

This section provides instructions for the removal and replacement of the Spectrum Master battery pack.

Note Many of the procedures in this section are generic, and apply to many similar instruments. Photos and illustrations used are representative and may show instruments other than the Spectrum Master.

1. Locate the battery access door illustrated in [Figure 4-1](#).



Figure 4-1. Battery Access Door Location and Finger Notch

2. With the Spectrum Master laying flat and face up on a stable surface, grab the battery access door notch and pull the battery door down towards the bottom of the instrument as shown in [Figure 4-2](#).



Figure 4-2. Opening the Battery Access Door

3. Remove the battery access door as shown [Figure 4-3](#).



Figure 4-3. Removing the Battery Access Door

4. With the battery access door completely removed, grasp the battery lanyard and pull the battery straight out of the unit, as illustrated in [Figure 4-4](#).



Figure 4-4. Removing the Battery

5. Replacement is the opposite of removal. Note the orientation of the battery contacts, and be sure to insert the battery with the contacts facing the bottom of the unit, refer to [Figure 4-5](#).



Figure 4-5. Battery Contacts and Orientation

Chapter 5 — Assembly Replacement

5-1 Replaceable Parts List

Refer to [Table 1-4, “List of Replaceable Parts” on page 1-5](#) for the list of replaceable parts. Refer to the following sections for basic replacement instructions.

Note

Many of the procedures in this section are generic, and apply to many similar instruments. Photos and illustrations used are representative and may show instruments other than the Spectrum Master.

5-2 Opening the Spectrum Master Case

Caution

Electrostatic Discharge (ESD) can damage the highly sensitive circuits in the instrument. Repair of damage that is found to be caused by electrostatic discharge is not covered under warranty.

This procedure provides instructions for opening the Spectrum Master case. With the case opened, the internal assemblies can be removed and replaced, as detailed in the following sections.

1. Remove the battery door and battery as shown in [Section 4-2 “Battery Pack Removal and Replacement” on page 4-2](#).
2. **Units with Option 31:** Carefully loosen and remove the lock nut and washer from the GPS SMA connector. Carefully push the SMA into the case ([Figure 5-1](#)).



Figure 5-1. Remove Option 31 Lock Nut and Washer

3. Place the Spectrum Master face down on a stable work surface that will not scratch the display.

4. Use a Phillips screwdriver to remove the four screws securing the two halves of the Spectrum Master case together ([Figure 5-2](#)).

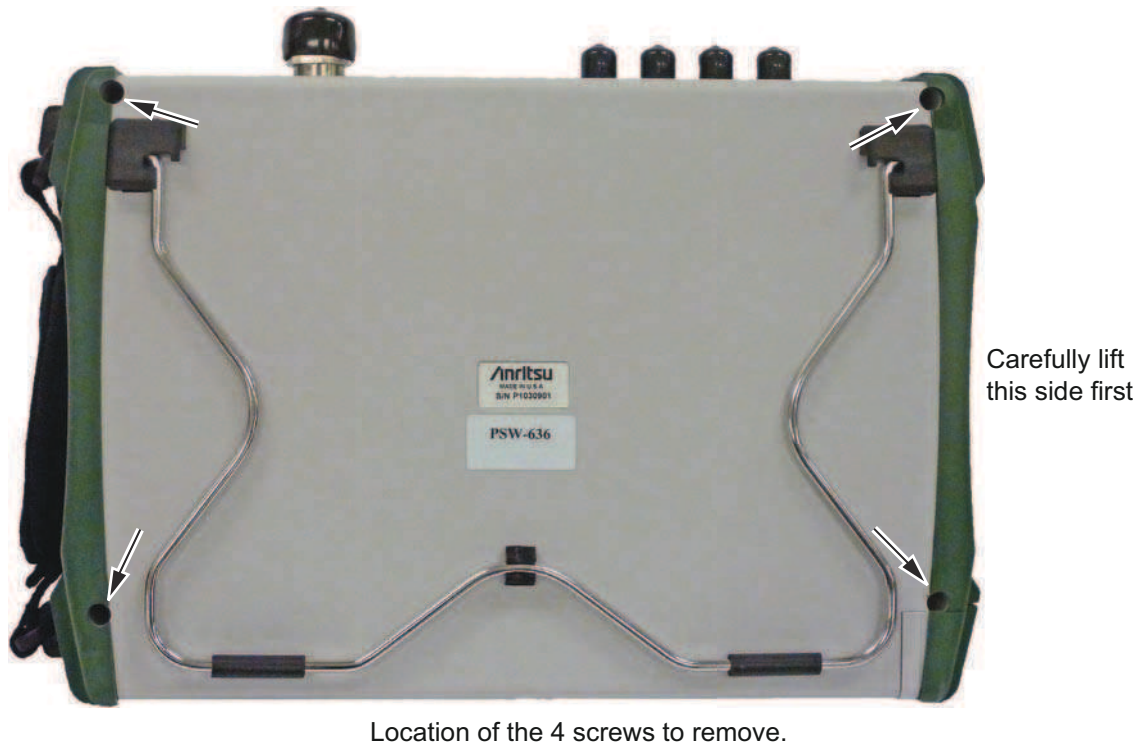

Figure 5-2. Remove the Four Screws

5. Carefully lift up on the side of the case shown and begin to separate the two halves.

Caution

Do not force or pull the two halves of the case apart completely, there are delicate cables attached between the two halves that must be disconnected first. Refer to [Figure 5-3](#) and [Figure 5-4](#).
Note the position and routing of the cables, they should be similarly routed when the unit is reassembled.

- Partially open the case and carefully disconnect the ribbon cable that connects the Spectrum Analyzer Assembly to the Main PCB Assembly. The cable is attached between the two sides of the Spectrum Master.

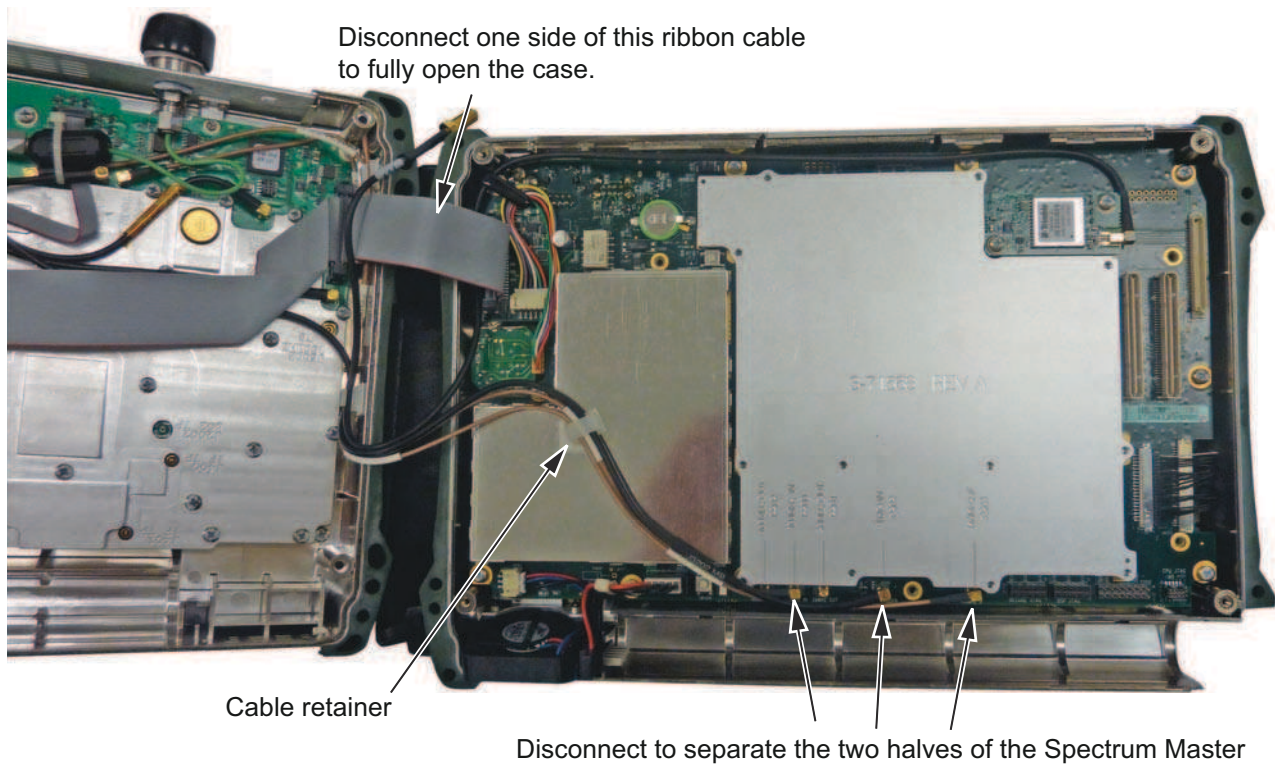

Figure 5-3. Disconnect the Cables Between the Two Halves of the Spectrum Master

- The Spectrum Master can now be fully opened and laid flat.
- Carefully remove the 3 connectors at the bottom of the Main PCB Assembly. Note the cable routing in the cable retainer and the location where each cable is connected.
- The two halves of the instrument can now be safely separated (Figure 5-4). Refer to the following sections of this chapter to remove and replace specific components of the instrument.

Note Proper routing of the cables is important for instrument performance. Note the cable routing.

- Reverse the above steps to reassemble the case.

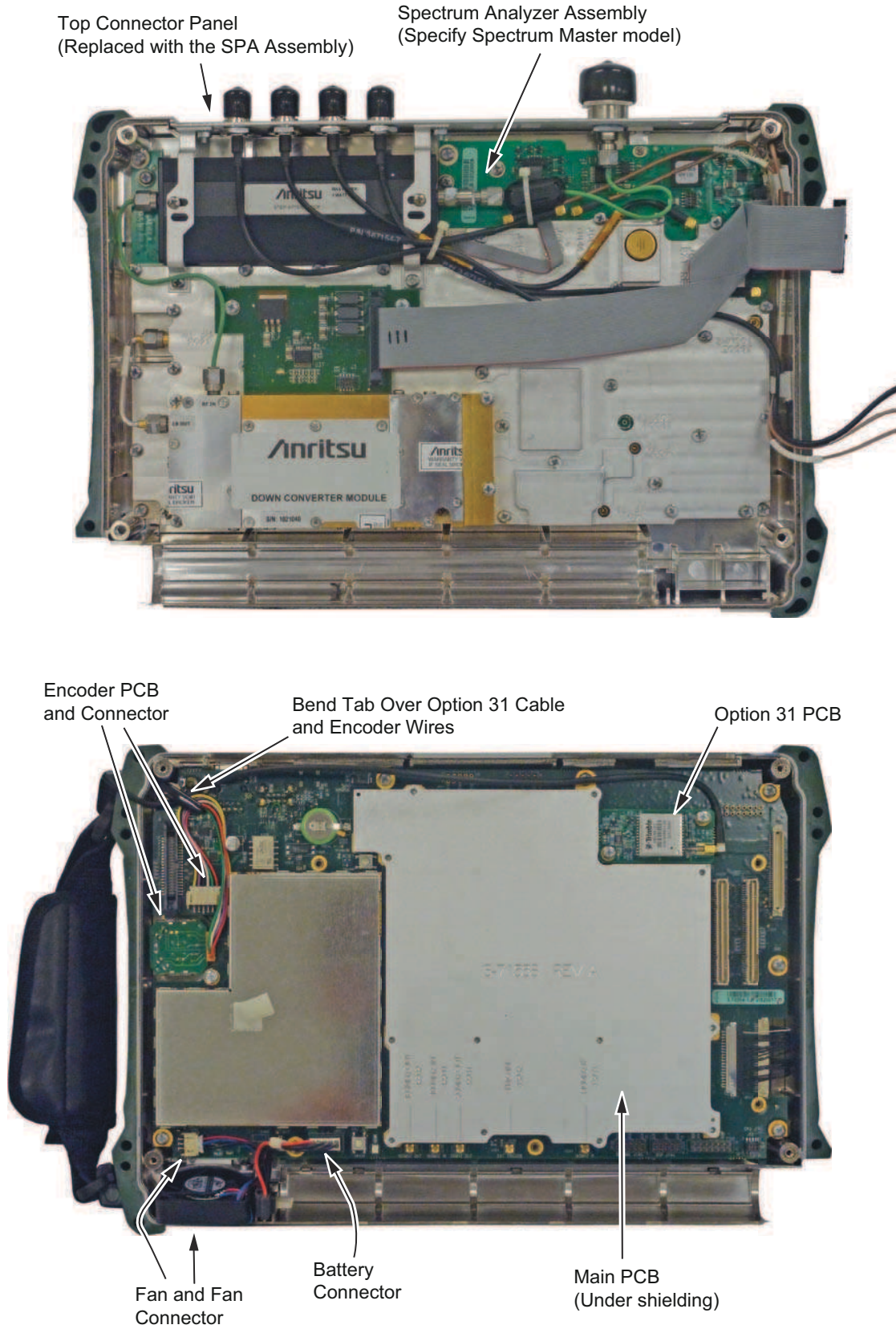

Figure 5-4. SPA Analyzer PCB Assembly (Top) and Main PCB Assembly (Bottom)

5-3 Spectrum Analyzer Module Assembly Replacement

This procedure provides instructions for removing and replacing the Spectrum Analyzer PCB Assembly. The Spectrum Analyzer Module Assembly is located in the back half of the case and includes the Top Connector Panel.

1. Open the case as described in [Section 5-2 “Opening the Spectrum Master Case”](#).
2. Use a Phillips screwdriver to remove the six screws securing the Spectrum Analyzer Module Assembly to the back half of the instrument case ([Figure 5-5](#)).
3. Carefully lift up and remove the Spectrum Analyzer PCB Assembly and attached Top Connector Panel.

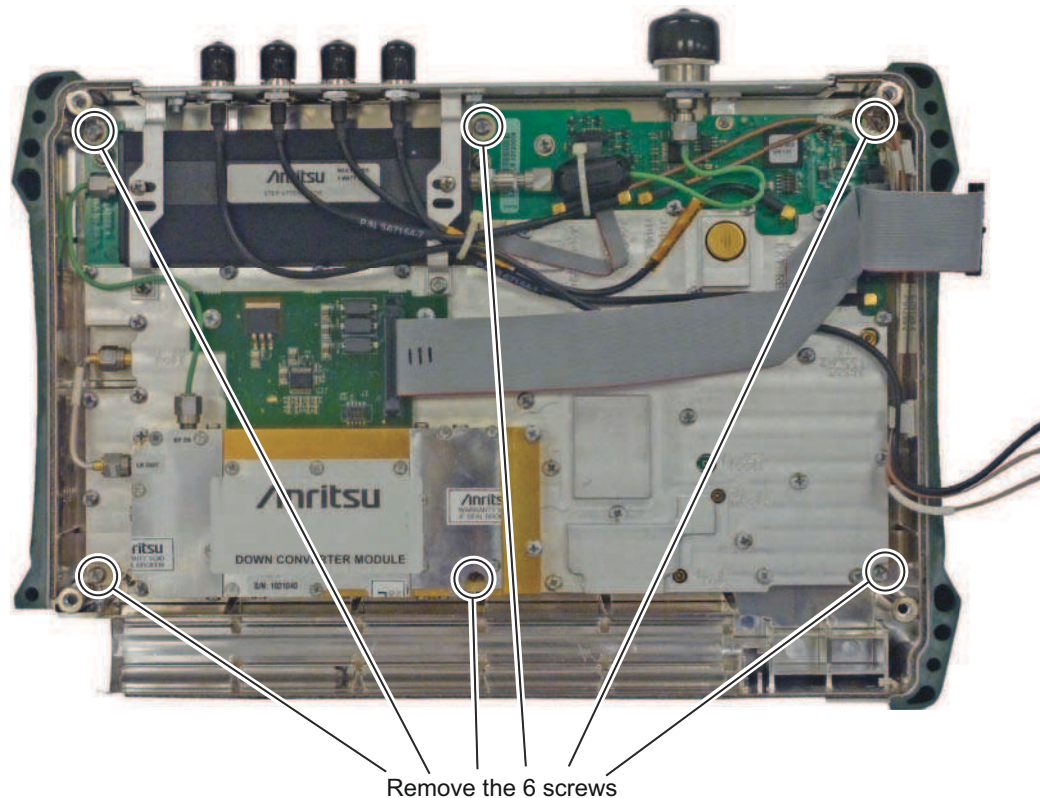

Figure 5-5. Spectrum Analyzer PCB Assembly

4. Reverse the above steps to install the new Spectrum Analyzer PCB Assembly.

Note

There is an RF gasket material between the two halves of the case, and in the connector panel grooves. Take care not to remove or damage this material when removing or replacing the Spectrum Analyzer Module and connector panel assembly.

5-4 Main PCB Assembly Replacement

This procedure provides instructions for replacing the Main PCB assembly. The Main PCB assembly is located in the front panel half of the instrument.

1. Open the case as described in [Section 5-2 “Opening the Spectrum Master Case”](#).
2. For Main PCB Assembly replacement of units with Option 31. Remove the two screws holding the GPS PCB to the Main PCB Assembly. Straighten the bend tab in the upper-left corner of the PCB and remove the GPS PCB board and cable from the Main PCB. Reattach the GPS PCB and reroute the cable on the replacement Main PCB Assembly.
3. Disconnect the Fan connector on the Main PCB Assembly ([Figure 5-6](#)).
4. Disconnect the Encoder Knob connector on the Main PCB Assembly.
5. Disconnect the Battery connector on the Main PCB Assembly.
6. Disconnect the LCD connector on the Main PCB Assembly.

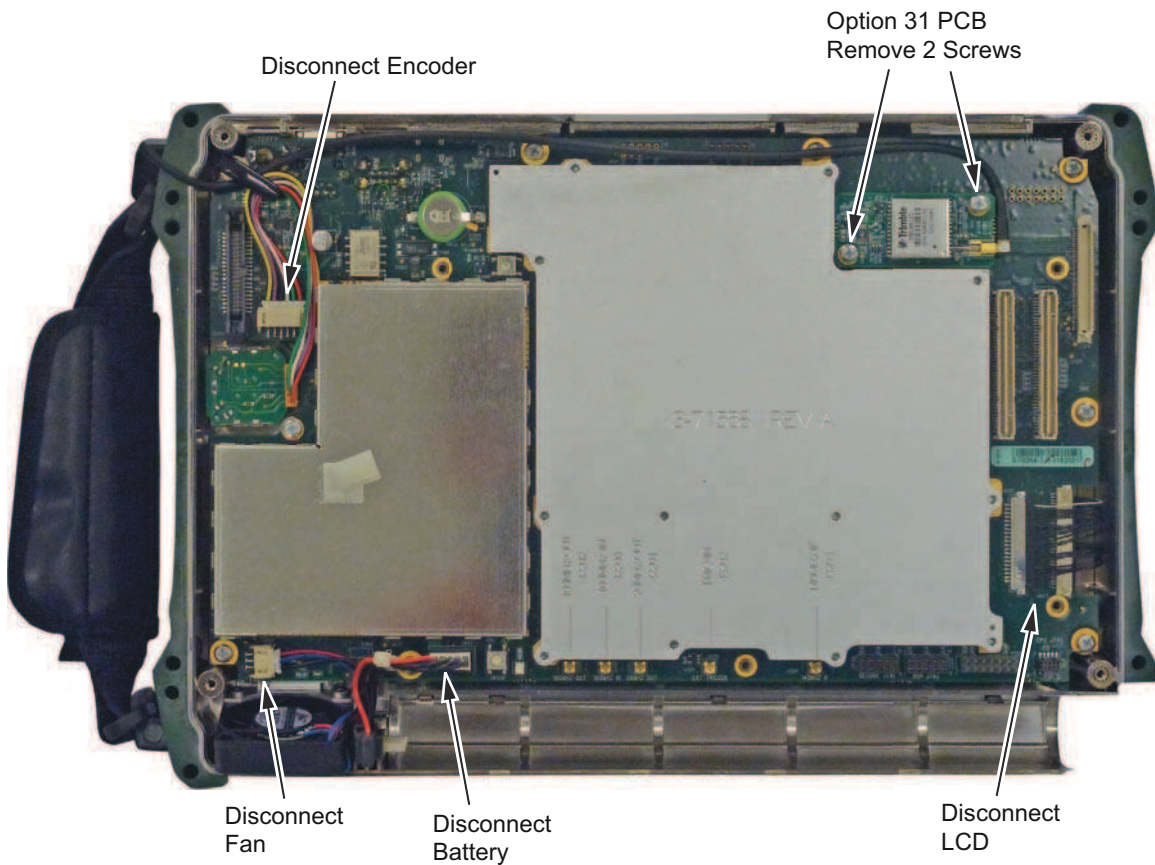

Figure 5-6. Disconnect the Cable Connectors on the Main PCB Assembly

7. Remove the 9 screws retaining the Main PCB Assembly to the Spectrum Master case ([Figure 5-7](#)).

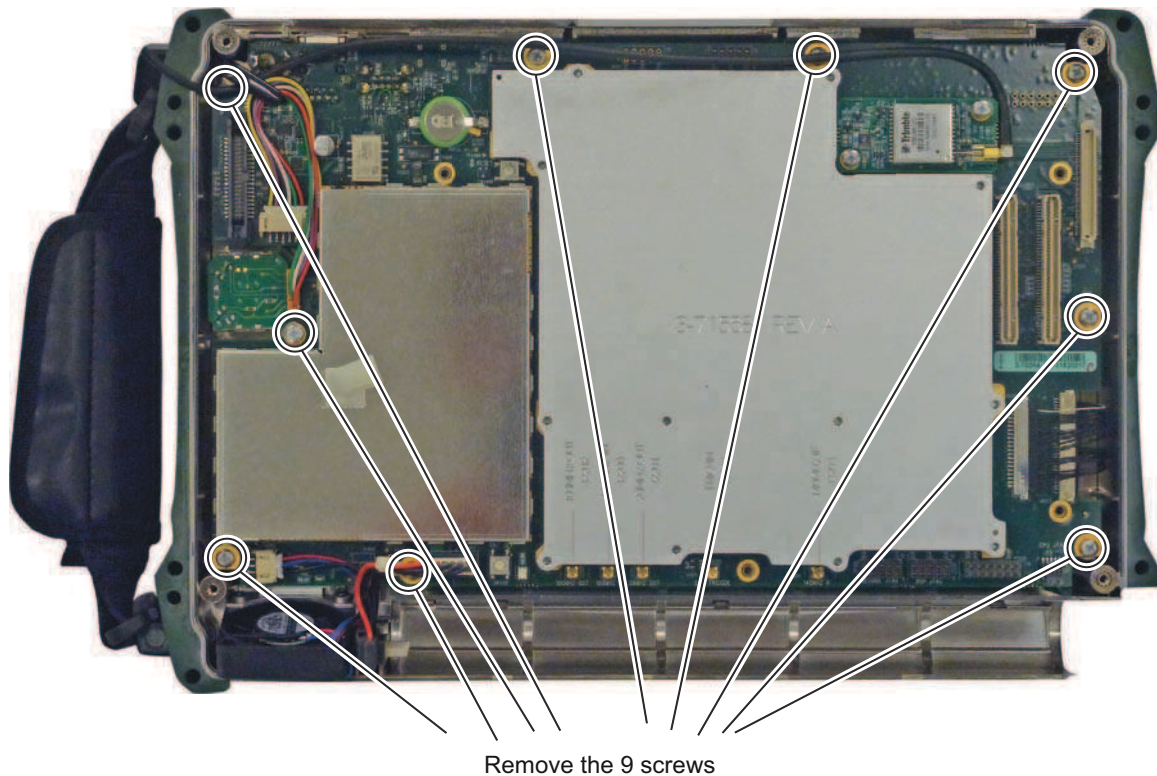

Figure 5-7. Remove the 9 Screws Retaining the Main PCB Assembly

8. Pull the Main PCB assembly out of the Front Panel section.
9. Remove the LCD Assembly and attached to the replacement Main PCB Assembly and described in [“LCD Assembly Replacement”](#) on page 5-8
10. Replacement is the reverse of removal.

Note

During reassembly confirm that the socket connector on the Main PCB aligns with the connector pin on the Keypad PCB shown in [Figure 5-11](#) on page 5-10.

5-5 LCD Assembly Replacement

This procedure provides instructions for removing and replacing the Liquid Crystal Display (LCD) once the Main PCB assembly has been separated from the Spectrum Master.

1. Open the case as described in [Section 5-2 “Opening the Spectrum Master Case”](#).
2. Remove the Main PCB assembly from the front panel as described in [Section 5-4 “Main PCB Assembly Replacement”](#).
3. Turn the Main PCB Assembly and disconnect the LCD backlight cable and if still attached, disconnect the LCD cable from the Main PCB.
4. Remove the four screws securing the LCD Display to the Main PCB assembly ([Figure 5-8](#)).

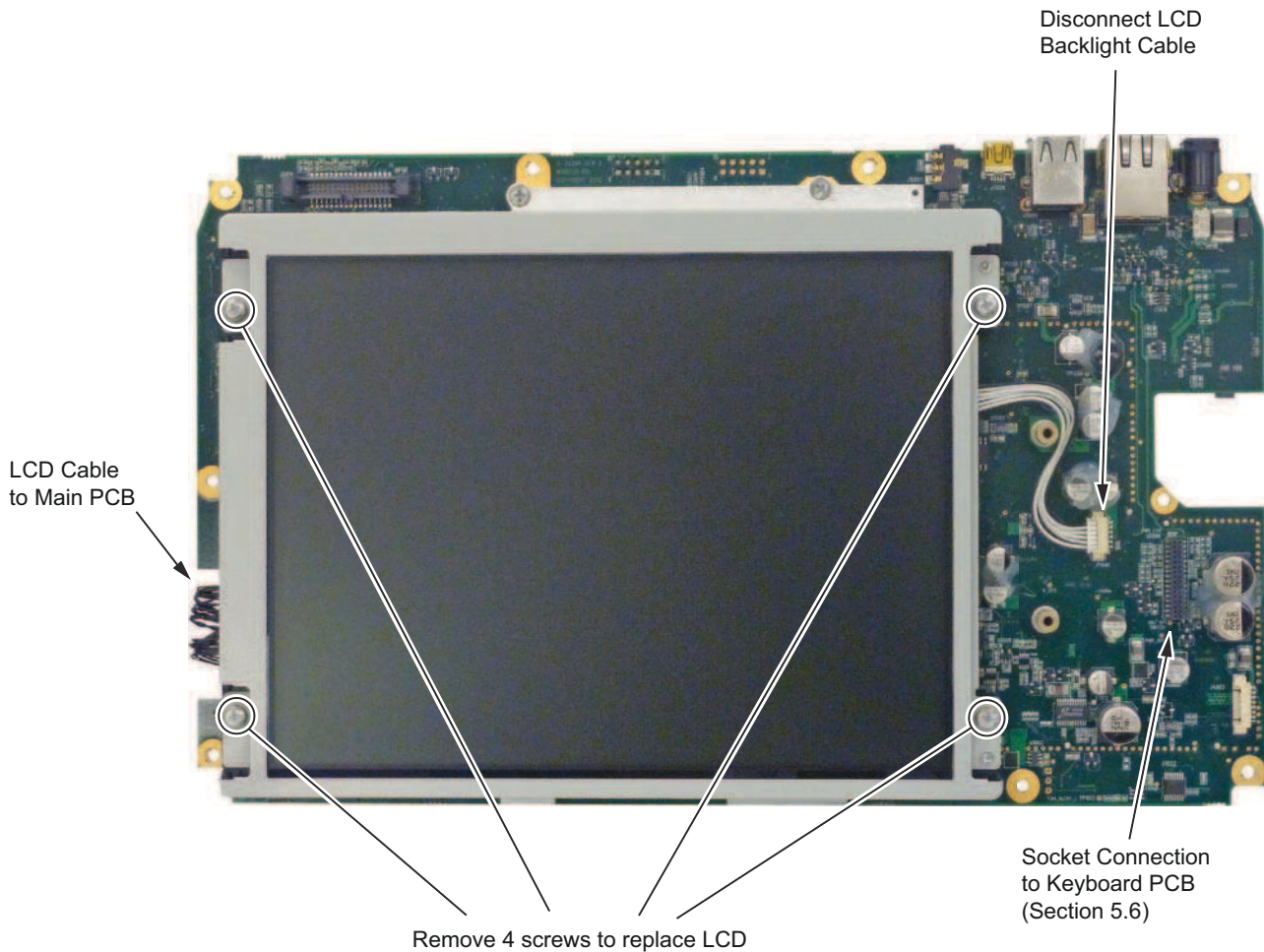

Figure 5-8. Replacing the LCD

5. Carefully remove the LCD.
6. Reverse the above steps to install the replacement LCD.

Note Pay attention to the routing of the LCD Backlight Cable. The cable must be positioned so it is not pinched when the assembly is reattached to the front panel.

5-6 Keypad Membrane and Main Keypad PCB Replacement

This procedure provides instructions for removing and replacing the keypad membrane and PCB.

Note The keypad PCB and membrane can be replaced without opening the Spectrum Master case.

1. Place the instrument face up on a protected work surface.
2. Carefully remove the rotary knob, nut and retaining washer.
3. There are eight locking tabs holding the keypad bezel to the case ([Figure 5-9](#)). Using a small flat-blade screwdriver, carefully pry the front bezel locking tabs free of the main body of the case. This will expose the keypad membrane.



Location of the 8 tabs holding the keypad bezel

Figure 5-9. Front Panel Keypad Bezel

- Remove the keypad membrane by carefully lifting the speaker and pulling the membrane off of the keypad PCB (Figure 5-10).

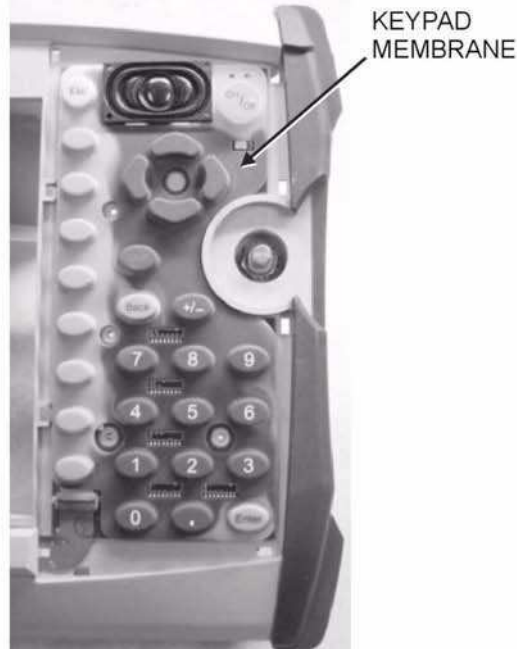

Figure 5-10. Keypad Membrane

Note The speaker is held in place by four locating pins on the inside of the keypad bezel. When the keypad bezel is removed, the speaker is only held by the fragile connecting wires. Use care not to damage the speaker wires when removing or replacing the keypad membrane or PCB.

- Disconnect the function key flexible switchpad from J2 of the keypad PCB by carefully lifting the locking tab on connector J2 to release the flexible switchpad (Figure 5-11).

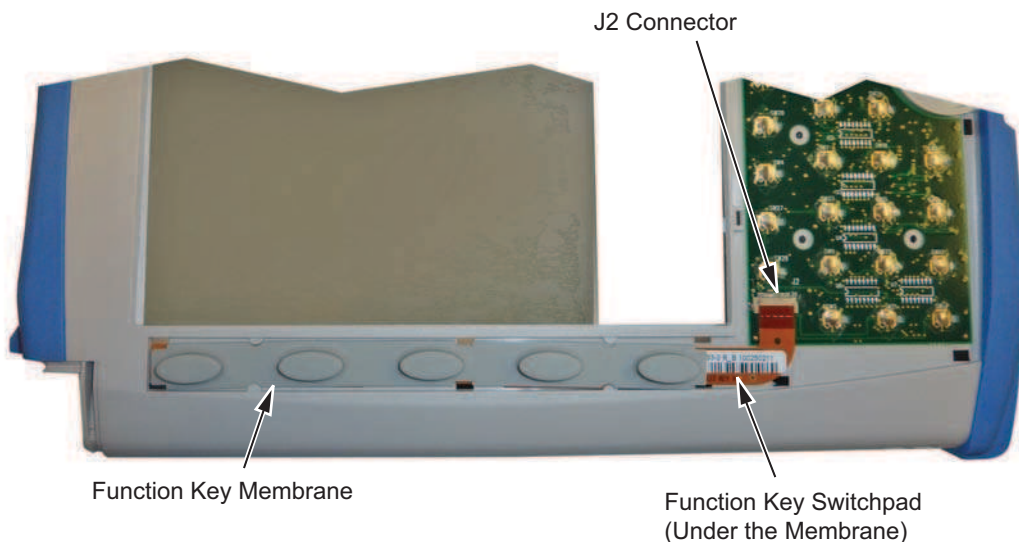

Figure 5-11. Keypad PCB

6. Remove the Main Keypad PCB, taking care not to damage the speaker wires. The Keyboard PCB is attached to the Main PCB Assembly with the socket connector shown in [Figure 5-8 on page 5-8](#).
7. Reverse the above steps to install the replacement assembly, with the following cautions:
 - Carefully close the locking tab on connector J2 to secure the flexible switchpad connection. The tab should “snap” into position when fully closed.
 - Insert the membrane over the keypad PCB, and under the speaker. Take care to properly orient the membrane so that the rubber pins are aligned with the keypad switches on the PCB.
 - The speaker is held in place by four locating pins on the inside of the keypad bezel. Verify that the four locating pins are properly seated into the four corner holes of the speaker when reinstalling the bezel.
 - Verify that all locking tabs are fully seated into the main body of the case when reinstalling the bezel.

5-7 Function Key Membrane and Switchpad Replacement

This procedure provides instructions for replacing the function key membrane and switchpad.

Note The function key membrane and switchplate can be replaced without opening the Spectrum Master.

1. Place the instrument face up on a protected work surface.
2. Remove the keypad bezel and membrane as described in [Section 5-6 “Keypad Membrane and Main Keypad PCB Replacement”](#).
3. There are six locking tabs holding the function key bezel to the case. Using a small flat blade screwdriver, carefully pry the function key bezel locking tabs free of the main body of the case. This will expose the function key membrane.
4. Remove the function key membrane by gently pulling the membrane up and away from the front panel ([Figure 5-12](#)).

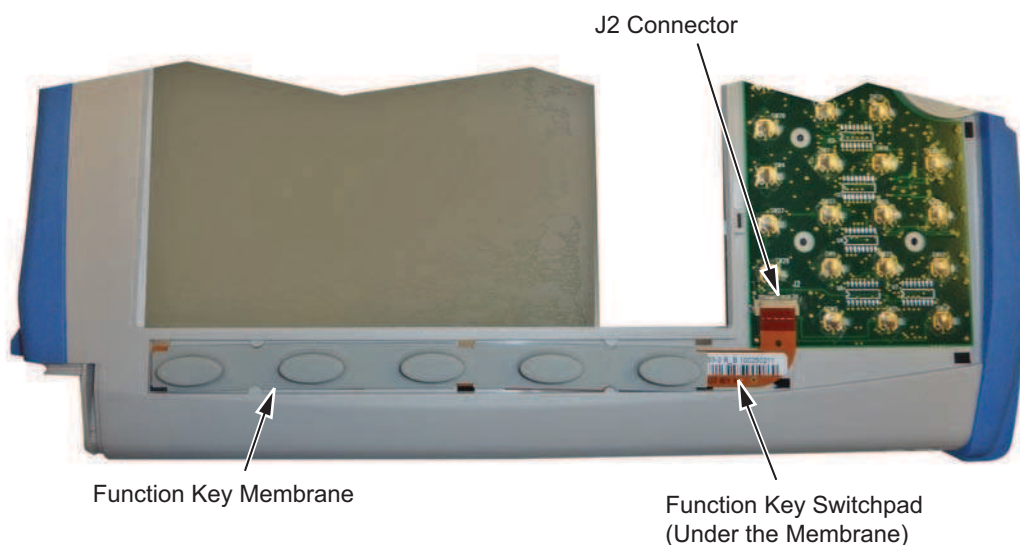

Figure 5-12. Function Key Membrane and Switchpad

5. Disconnect the function key flexible switchpad from J2 of the keypad PCB by carefully lifting the locking tab on connector J2 to release the flexible switchpad ([Figure 5-12](#)).
6. Reverse the above steps to install the replacement switchpad or membrane.
 - Carefully close the locking tab on connector J2 to secure the flexible switchpad connection. The tab should “snap” into position when fully closed.

Chapter 6 — Troubleshooting

This chapter describes the primary troubleshooting operations that can be performed by all Anritsu Service Centers. Perform the troubleshooting suggestions in the order they are listed. Operators of the Spectrum Master MS272xC should refer to the User Guide for troubleshooting help.

Only qualified Anritsu personnel should replace internal assemblies. Major subassemblies shown in [Table 1-4, “List of Replaceable Parts” on page 1-5](#) are typically the items that may be replaced. Because they are highly fragile, items that must be soldered may not be replaced without special training. Removal of RF shields from PC boards or adjustment of screws on or near the shields will detune sensitive RF circuits and will result in degraded instrument performance.

Turn-on Problems

Unit cannot boot-up, no activity occurs when the On/Off key is pressed:

1. Battery may be fully discharged. Use an external charger (Anritsu part number 2000-1374) to charge a completely discharged battery.
2. Battery may be the wrong type. Use only Anritsu approved battery packs. Some non-approved battery packs will fit into the MS272xC, but are electrically incompatible and will not charge correctly.
3. External power supply may have failed or be the wrong type. Replace the external power supply.
4. On/Off switch is damaged. Replace the keypad PCB or rubber keypad.
5. Main PCB has failed. Replace the Main PCB assembly.

Unit begins the boot process, but does not complete boot-up:

1. Using Master Software Tools, perform the Emergency Repair procedure, then update the system software (via the Tools menu).
2. Main PCB has failed. Replace the Main PCB assembly.

Unit makes normal boot-up sounds, but the display has a problem:

1. If the display is dim, check the brightness setting under the System Menu / System Options.
2. Replace the Backlight Driver PCB.
3. Replace the LCD assembly.
4. The Main PCB has failed. Replace the Main PCB assembly.

Boot-up Self Test fails:

1. Perform a Master Reset.
If the message relates to the RTC battery, replace the RTC battery on the Main PCB.
2. The Main PCB has failed. Replace the Main PCB assembly

Other Problems

Battery Pack Charging Problems: refer to [Chapter 4, “Battery Information”](#).

Lock Error messages:

1. This message normally appears for 2 to 3 seconds when an external 10 MHz Reference is applied.
2. Spectrum Analyzer PCB has failed. Replace the Spectrum Analyzer PCB assembly.

Spectrum Analyzer Problems:

1. Inspect the Spectrum Analyzer RF In connector for damage.
2. Refer to the User Guide.
3. Update system software using Master Software Tools (via Tools menu).
4. Spectrum Analyzer PCB has failed. Replace the Spectrum Analyzer PCB assembly.

Other Issues:

1. Perform a Master Reset.
2. Refer to the User Guide.
3. Update system software using Master Software Tools (via Tools menu).
4. Replace the Main Spectrum Analyzer PCB assembly.

Appendix A — Test Records

This appendix provides test records that can be used to record the performance of the MS272xC Spectrum Master. Anritsu recommends that you make a copy of the following test record pages and document the measurements each time a Performance Verification is performed. Continuing to document this process each time it is performed provides a detailed history of instrument performance, which can allow you to observe trends.

MS272__C Firmware Rev: _____ Operator: _____ Date: _____
 Serial Number: _____ Options: _____

A-1 Test Records for Spectrum Analyzer Verification

Table A-1. Spectrum Analyzer Frequency Accuracy

Frequency	Measured Value	Error	Specification
1 GHz	GHz	Hz	± 300 Hz
7 GHz (MS2722C only)	GHz	Hz	± 2100 Hz
12 GHz(MS2723C only)	GHz	Hz	± 3600 Hz
18 GHz(MS2724C only)	GHz	Hz	± 5400 Hz
30 GHz (MS2725C only)	GHz	Hz	± 9000 Hz
40 GHz (MS2726C only)	GHz	Hz	± 12000 Hz

Table A-2. Spectrum Analyzer 1.0 GHz SSB Phase Noise Verification

Frequency Offset	Measured Value	Specification
10 kHz	dBc/Hz	-100 dBc/Hz
100 kHz	dBc/Hz	-102 dBc/Hz
1000 kHz	dBc/Hz	-107 dBc/Hz
10 MHz	dBc/Hz	-120 dBc/Hz

Table A-3. Spectrum Analyzer Second Harmonic Distortion

Frequency	Measured Value	Second Harmonic Distortion	Specification
50.1 MHz	dBm		
100.2 MHz	dBm	dBc	-54 dBc max

MS272_C Firmware Rev: _____ Operator: _____ Date: _____
 Serial Number: _____ Options: _____

Input Related Spurs for –30 dBm Input at 1000 MHz

Table A-4. Measured Input Signal Level at 1000 MHz

Start Freq	Stop Freq	Measured Spur Level	Calculated IRS	Specification
1000 MHz Center Frequency		dBm		
719 MHz	721 MHz	dBm	dBc	≤ -60 dBc

Input Related Spurs for –30 dBm Input at 3273 MHz

Table A-5. Measured Input Signal Level at 3273 MHz

Start Freq	Stop Freq	Measured Spur Level	Calculated IRS	Specification
3275 MHz Center Frequency		dBm		
2423 MHz	3271 MHz	dBm	dBc	≤ -60 dBc
3275 MHz	4123 MHz	dBm	dBc	≤ -60 dBc

Input Related Spurs for –30 dBm Input at 8000 MHz

Table A-6. Measured Input Signal Level at 8000 MHz

Start Freq	Stop Freq	Measured Spur Level	Calculated IRS	Specification
8000 MHz Center Frequency		dBm		
7719 MHz	7721 MHz	dBm	dBc	≤ -60 dBc

Input Related Spurs for –30 dBm Input at 15000 MHz

Table A-7. Measured Input Signal Level at 15000 MHz

Start Freq	Stop Freq	Measured Spur Level	Calculated IRS	Specification
15000 MHz Center Frequency		dBm		
14719 MHz	14721 MHz	dBm	dBc	≤ -60 dBc

MS272_C Firmware Rev: _____ Operator: _____ Date: _____
 Serial Number: _____ Options: _____

Table A-8. Spectrum Analyzer Resolution Bandwidth Accuracy

RBW Setting	Span	VBW	Measured Value	Specification
10 MHz	20 MHz	1 MHz	MHz	9 MHz to 11 MHz
3 MHz	6 MHz	300 kHz	MHz	2.7 MHz to 3.3 MHz
1 MHz	2 MHz	100 kHz	MHz	900 kHz to 1.1 MHz
300 kHz	600 kHz	30 kHz	kHz	270 kHz to 330 kHz
100 kHz	200 kHz	10 kHz	kHz	90 kHz to 110 kHz
30 kHz	60 kHz	3 kHz	kHz	27 kHz to 33 kHz
10 kHz	20 kHz	1 kHz	kHz	9 kHz to 11 kHz
3 kHz	6 kHz	300 Hz	kHz	2.7 kHz to 3.3 kHz
1 kHz	2 kHz	100 Hz	Hz	900 Hz to 1.1 kHz
300 Hz	600 Hz	30 Hz	Hz	270 Hz to 330 Hz
100 Hz	200 Hz	10 Hz	Hz	90 Hz to 110 Hz
30 Hz	60 Hz	3 Hz	Hz	27 Hz to 33 Hz
10 Hz	20 Hz	1 Hz	Hz	9 Hz to 11 Hz
3 Hz	10 Hz	1 Hz	Hz	2.7 Hz to 3.3 Hz
1 Hz	2 Hz	1 Hz	Hz	0.9 Hz to 1.1 Hz

MS272_C Firmware Rev: _____ Operator: _____ Date: _____
 Serial Number: _____ Options: _____

Table A-9. Characterization Chart for 50 MHz Amplitude Accuracy Verification

Test Power Level at 50 MHz	Required Sensor B Reading
0 dBm	dBm
-4 dBm	dBm
-10 dBm	dBm
-14 dBm	dBm
-20 dBm	dBm
-24 dBm	dBm
-30 dBm	dBm
-34 dBm	dBm
-40 dBm	dBm
-44 dBm	dBm
-50 dBm	dBm

Note

The listed Amplitude Accuracy specifications apply when the instrument is being verified in an environment between 20°C and 30°C after a 30 minute warm-up period. For an instrument that is not being verified in a temperature controlled environment but within a temperature range between -10°C and 50°C (-10°C and 40°C for MS2726C only) and after a 60 minute warm-up, add ± 1 dB to the Amplitude Accuracy specification for frequencies from 100 kHz to 32 GHz, add ± 2 dB to the Amplitude Accuracy specification for frequencies from 32 GHz to 40 GHz.

Table A-10. 50 MHz Amplitude Accuracy Verification, Specification = ± 1.3 dB

Input Power Level	Reference Level	Input Atten. Level	Measured Reading
0 dBm	10 dBm	30 dB	dBm
-4 dBm	10 dBm	30 dB	dBm
-10 dBm	0 dBm	20 dB	dBm
-14 dBm	0 dBm	20 dB	dBm
-20 dBm	-10 dBm	10 dB	dBm
-24 dBm	-10 dBm	10 dB	dBm
-30 dBm	-20 dBm	0 dB	dBm
-34 dBm	-20 dBm	0 dB	dBm
-40 dBm	-30 dBm	0 dB	dBm
-44 dBm	-30 dBm	0 dB	dBm
-50 dBm	-40 dBm	0 dB	dBm

MS272_C Firmware Rev: _____ Operator: _____ Date: _____
 Serial Number: _____ Options: _____

Table A-11. Characterization Chart for Fixed Level with Varying Frequency (1 of 2)

Frequency	-2 dBm (MS2722C, MS2723C, MS2724C)	-30 dBm
	-5 dBm (MS2725C, MS2726C)	
10.1 MHz	dBm	dBm
100 MHz	dBm	dBm
500 MHz	dBm	dBm
1000 MHz	dBm	dBm
2000 MHz	dBm	dBm
3000 MHz	dBm	dBm
4000 MHz	dBm	dBm
5000 MHz	dBm	dBm
6000 MHz	dBm	dBm
7000 MHz	dBm	dBm
8000 MHz	dBm	dBm
8999.995 MHz	dBm	dBm
9000 MHz	dBm	dBm
10000 MHz	dBm	dBm
11000 MHz	dBm	dBm
12000 MHz	dBm	dBm
12999.995 MHz	dBm	dBm
13000 MHz	dBm	dBm
14000 MHz	dBm	dBm
15000 MHz	dBm	dBm
16000 MHz	dBm	dBm
17000 MHz	dBm	dBm
18000 MHz	dBm	dBm
19000 MHz	dBm	dBm
19999.995 MHz	dBm	dBm
20000 MHz	dBm	dBm
21000 MHz	dBm	dBm

MS272_C Firmware Rev: _____ Operator: _____ Date: _____
 Serial Number: _____ Options: _____

Table A-11. Characterization Chart for Fixed Level with Varying Frequency (2 of 2)

Frequency	-2 dBm (MS2722C, MS2723C, MS2724C)	-30 dBm
	-5 dBm (MS2725C, MS2726C)	
22000 MHz	dBm	dBm
23000 MHz	dBm	dBm
24000 MHz	dBm	dBm
25000 MHz	dBm	dBm
26000 MHz	dBm	dBm
27000 MHz	dBm	dBm
28000 MHz	dBm	dBm
29000 MHz	dBm	dBm
30000 MHz	dBm	dBm
31000 MHz	dBm	dBm
31999.995 MHz	dBm	dBm
32000 MHz	dBm	dBm
33000 MHz	dBm	dBm
35000 MHz	dBm	dBm
35000 MHz	dBm	dBm
36000 MHz	dBm	dBm
37000 MHz	dBm	dBm
38000 MHz	dBm	dBm
39000 MHz	dBm	dBm
40000 MHz	dBm	dBm

MS272_C Firmware Rev: _____ Operator: _____ Date: _____
 Serial Number: _____ Options: _____

Note

The listed Amplitude Accuracy specifications apply when the instrument is being verified in an environment between 20°C and 30°C after a 30 minute warm-up period. For an instrument that is not being verified in a temperature controlled environment but within a temperature range between -10°C and 50°C (-10°C and 40°C for MS2726C only) and after a 60 minute warm-up, add ± 1 dB to the Amplitude Accuracy specification for frequencies from 100 kHz to 32 GHz, add ± 2 dB to the Amplitude Accuracy specification for frequencies from 32 GHz to 40 GHz.

Table A-12. Verification at 10.1 MHz, Specification = ± 1.3 dB

Input Power	Atten Lvl	Marker 1 Reading
-30 dBm	0 dB	dBm
-30 dBm	5 dB	dBm
-30 dBm	10 dB	dBm
-30 dBm	20 dB	dBm
-2 dBm or -5 dBm	30 dB	dBm
-2 dBm or -5 dBm	40 dB	dBm
-2 dBm or -5 dBm	50 dB	dBm
-2 dBm or -5 dBm	60 dB	dBm

Table A-13. Verification at 100 MHz, Specification = ± 1.3 dB

Input Power	Atten Lvl	Marker 1 Reading
-30 dBm	0 dB	dBm
-30 dBm	5 dB	dBm
-30 dBm	10 dB	dBm
-30 dBm	20 dB	dBm
-2 dBm or -5 dBm	30 dB	dBm
-2 dBm or -5 dBm	40 dB	dBm
-2 dBm or -5 dBm	50 dB	dBm
-2 dBm or -5 dBm	60 dB	dBm

MS272_C Firmware Rev: _____ Operator: _____ Date: _____
 Serial Number: _____ Options: _____

Note

The listed Amplitude Accuracy specifications apply when the instrument is being verified in an environment between 20°C and 30°C after a 30 minute warm-up period. For an instrument that is not being verified in a temperature controlled environment but within a temperature range between -10°C and 50°C (-10°C and 40°C for MS2726C only) and after a 60 minute warm-up, add ± 1 dB to the Amplitude Accuracy specification for frequencies from 100 kHz to 32 GHz, add ± 2 dB to the Amplitude Accuracy specification for frequencies from 32 GHz to 40 GHz.

Table A-14. Verification at 500 MHz, Specification = ± 1.3 dB

Input Power	Atten Lvl	Marker 1 Reading
-30 dBm	0 dB	dBm
-30 dBm	5 dB	dBm
-30 dBm	10 dB	dBm
-30 dBm	20 dB	dBm
-2 dBm or -5 dBm	30 dB	dBm
-2 dBm or -5 dBm	40 dB	dBm
-2 dBm or -5 dBm	50 dB	dBm
-2 dBm or -5 dBm	60 dB	dBm

Table A-15. Verification at 1.0 GHz, Specification = ± 1.3 dB

Input Power	Atten Lvl	Marker 1 Reading
-30 dBm	0 dB	dBm
-30 dBm	5 dB	dBm
-30 dBm	10 dB	dBm
-30 dBm	20 dB	dBm
-2 dBm or -5 dBm	30 dB	dBm
-2 dBm or -5 dBm	40 dB	dBm
-2 dBm or -5 dBm	50 dB	dBm
-2 dBm or -5 dBm	60 dB	dBm

MS272_C Firmware Rev: _____ Operator: _____ Date: _____
 Serial Number: _____ Options: _____

Note

The listed Amplitude Accuracy specifications apply when the instrument is being verified in an environment between 20°C and 30°C after a 30 minute warm-up period. For an instrument that is not being verified in a temperature controlled environment but within a temperature range between -10°C and 50°C (-10°C and 40°C for MS2726C only) and after a 60 minute warm-up, add ± 1 dB to the Amplitude Accuracy specification for frequencies from 100 kHz to 32 GHz, add ± 2 dB to the Amplitude Accuracy specification for frequencies from 32 GHz to 40 GHz.

Table A-16. Verification at 2.0 GHz, Specification = ± 1.3 dB

Input Power	Atten Lvl	Marker 1 Reading
-30 dBm	0 dB	dBm
-30 dBm	5 dB	dBm
-30 dBm	10 dB	dBm
-30 dBm	20 dB	dBm
-2 dBm or -5 dBm	30 dB	dBm
-2 dBm or -5 dBm	40 dB	dBm
-2 dBm or -5 dBm	50 dB	dBm
-2 dBm or -5 dBm	60 dB	dBm

Table A-17. Verification at 3.0 GHz, Specification = ± 1.3 dB

Input Power	Atten Lvl	Marker 1 Reading
-30 dBm	0 dB	dBm
-30 dBm	5 dB	dBm
-30 dBm	10 dB	dBm
-30 dBm	20 dB	dBm
-2 dBm or -5 dBm	30 dB	dBm
-2 dBm or -5 dBm	40 dB	dBm
-2 dBm or -5 dBm	50 dB	dBm
-2 dBm or -5 dBm	60 dB	dBm

MS272_C Firmware Rev: _____ Operator: _____ Date: _____
 Serial Number: _____ Options: _____

Note

The listed Amplitude Accuracy specifications apply when the instrument is being verified in an environment between 20°C and 30°C after a 30 minute warm-up period. For an instrument that is not being verified in a temperature controlled environment but within a temperature range between -10°C and 50°C (-10°C and 40°C for MS2726C only) and after a 60 minute warm-up, add ± 1 dB to the Amplitude Accuracy specification for frequencies from 100 kHz to 32 GHz, add ± 2 dB to the Amplitude Accuracy specification for frequencies from 32 GHz to 40 GHz.

Table A-18. Verification at 4.0 GHz, Specification = ± 1.3 dB

Input Power	Atten Lvl	Marker 1 Reading
-30 dBm	0 dB	dBm
-30 dBm	5 dB	dBm
-30 dBm	10 dB	dBm
-30 dBm	20 dB	dBm
-2 dBm or -5 dBm	30 dB	dBm
-2 dBm or -5 dBm	40 dB	dBm
-2 dBm or -5 dBm	50 dB	dBm
-2 dBm or -5 dBm	60 dB	dBm

Table A-19. Verification at 5.0 GHz, Specification = ± 1.3 dB

Input Power	Atten Lvl	Marker 1 Reading
-30 dBm	0 dB	dBm
-30 dBm	5 dB	dBm
-30 dBm	10 dB	dBm
-30 dBm	20 dB	dBm
-2 dBm or -5 dBm	30 dB	dBm
-2 dBm or -5 dBm	40 dB	dBm
-2 dBm or -5 dBm	50 dB	dBm
-2 dBm or -5 dBm	60 dB	dBm

MS272_C Firmware Rev: _____ Operator: _____ Date: _____
 Serial Number: _____ Options: _____

Note

The listed Amplitude Accuracy specifications apply when the instrument is being verified in an environment between 20°C and 30°C after a 30 minute warm-up period. For an instrument that is not being verified in a temperature controlled environment but within a temperature range between -10°C and 50°C (-10°C and 40°C for MS2726C only) and after a 60 minute warm-up, add ± 1 dB to the Amplitude Accuracy specification for frequencies from 100 kHz to 32 GHz, add ± 2 dB to the Amplitude Accuracy specification for frequencies from 32 GHz to 40 GHz.

Table A-20. Verification at 6.0 GHz, Specification = ± 1.3 dB

Input Power	Atten Lvl	Marker 1 Reading
-30 dBm	0 dB	dBm
-30 dBm	5 dB	dBm
-30 dBm	10 dB	dBm
-30 dBm	20 dB	dBm
-2 dBm or -5 dBm	30 dB	dBm
-2 dBm or -5 dBm	40 dB	dBm
-2 dBm or -5 dBm	50 dB	dBm
-2 dBm or -5 dBm	60 dB	dBm

Table A-21. Verification at 7.0 GHz, Specification = ± 1.3 dB

Input Power	Atten Lvl	Marker 1 Reading
-30 dBm	0 dB	dBm
-30 dBm	5 dB	dBm
-30 dBm	10 dB	dBm
-30 dBm	20 dB	dBm
-2 dBm or -5 dBm	30 dB	dBm
-2 dBm or -5 dBm	40 dB	dBm
-2 dBm or -5 dBm	50 dB	dBm
-2 dBm or -5 dBm	60 dB	dBm

MS272_C Firmware Rev: _____ Operator: _____ Date: _____
 Serial Number: _____ Options: _____

Note

The listed Amplitude Accuracy specifications apply when the instrument is being verified in an environment between 20°C and 30°C after a 30 minute warm-up period. For an instrument that is not being verified in a temperature controlled environment but within a temperature range between -10°C and 50°C (-10°C and 40°C for MS2726C only) and after a 60 minute warm-up, add ± 1 dB to the Amplitude Accuracy specification for frequencies from 100 kHz to 32 GHz, add ± 2 dB to the Amplitude Accuracy specification for frequencies from 32 GHz to 40 GHz.

Table A-22. Verification at 8.0 GHz, Specification = ± 1.3 dB

Input Power	Atten Lvl	Marker 1 Reading
-30 dBm	0 dB	dBm
-30 dBm	5 dB	dBm
-30 dBm	10 dB	dBm
-30 dBm	20 dB	dBm
-2 dBm or -5 dBm	30 dB	dBm
-2 dBm or -5 dBm	40 dB	dBm
-2 dBm or -5 dBm	50 dB	dBm
-2 dBm or -5 dBm	60 dB	dBm

Table A-23. Verification at 8.999995 GHz, Specification = ± 1.3 dB

Input Power	Atten Lvl	Marker 1 Reading
-30 dBm	0 dB	dBm
-30 dBm	5 dB	dBm
-30 dBm	10 dB	dBm
-30 dBm	20 dB	dBm
-2 dBm or -5 dBm	30 dB	dBm
-2 dBm or -5 dBm	40 dB	dBm
-2 dBm or -5 dBm	50 dB	dBm
-2 dBm or -5 dBm	60 dB	dBm

MS272_C Firmware Rev: _____ Operator: _____ Date: _____
 Serial Number: _____ Options: _____

Note

The listed Amplitude Accuracy specifications apply when the instrument is being verified in an environment between 20°C and 30°C after a 30 minute warm-up period. For an instrument that is not being verified in a temperature controlled environment but within a temperature range between -10°C and 50°C (-10°C and 40°C for MS2726C only) and after a 60 minute warm-up, add ± 1 dB to the Amplitude Accuracy specification for frequencies from 100 kHz to 32 GHz, add ± 2 dB to the Amplitude Accuracy specification for frequencies from 32 GHz to 40 GHz.

Table A-24. Verification at 9.0 GHz, Specification = ± 1.3 dB

Input Power	Atten Lvl	Marker 1 Reading
-30 dBm	0 dB	dBm
-30 dBm	5 dB	dBm
-30 dBm	10 dB	dBm
-30 dBm	20 dB	dBm
-2 dBm or -5 dBm	30 dB	dBm
-2 dBm or -5 dBm	40 dB	dBm
-2 dBm or -5 dBm	50 dB	dBm
-2 dBm or -5 dBm	60 dB	dBm

Table A-25. Verification at 10.0 GHz, Specification = ± 1.3 dB

Input Power	Atten Lvl	Marker 1 Reading
-30 dBm	0 dB	dBm
-30 dBm	5 dB	dBm
-30 dBm	10 dB	dBm
-30 dBm	20 dB	dBm
-2 dBm or -5 dBm	30 dB	dBm
-2 dBm or -5 dBm	40 dB	dBm
-2 dBm or -5 dBm	50 dB	dBm
-2 dBm or -5 dBm	60 dB	dBm

MS272_C Firmware Rev: _____ Operator: _____ Date: _____
 Serial Number: _____ Options: _____

Note

The listed Amplitude Accuracy specifications apply when the instrument is being verified in an environment between 20°C and 30°C after a 30 minute warm-up period. For an instrument that is not being verified in a temperature controlled environment but within a temperature range between -10°C and 50°C (-10°C and 40°C for MS2726C only) and after a 60 minute warm-up, add ± 1 dB to the Amplitude Accuracy specification for frequencies from 100 kHz to 32 GHz, add ± 2 dB to the Amplitude Accuracy specification for frequencies from 32 GHz to 40 GHz.

Table A-26. Verification at 11.0 GHz, Specification = ± 1.3 dB

Input Power	Atten Lvl	Marker 1 Reading
-30 dBm	0 dB	dBm
-30 dBm	5 dB	dBm
-30 dBm	10 dB	dBm
-30 dBm	20 dB	dBm
-2 dBm or -5 dBm	30 dB	dBm
-2 dBm or -5 dBm	40 dB	dBm
-2 dBm or -5 dBm	50 dB	dBm
-2 dBm or -5 dBm	60 dB	dBm

Table A-27. Verification at 12.0 GHz, Specification = ± 1.3 dB

Input Power	Atten Lvl	Marker 1 Reading
-30 dBm	0 dB	dBm
-30 dBm	5 dB	dBm
-30 dBm	10 dB	dBm
-30 dBm	20 dB	dBm
-2 dBm or -5 dBm	30 dB	dBm
-2 dBm or -5 dBm	40 dB	dBm
-2 dBm or -5 dBm	50 dB	dBm
-2 dBm or -5 dBm	60 dB	dBm

MS272_C Firmware Rev: _____ Operator: _____ Date: _____
 Serial Number: _____ Options: _____

Note

The listed Amplitude Accuracy specifications apply when the instrument is being verified in an environment between 20°C and 30°C after a 30 minute warm-up period. For an instrument that is not being verified in a temperature controlled environment but within a temperature range between -10°C and 50°C (-10°C and 40°C for MS2726C only) and after a 60 minute warm-up, add ± 1 dB to the Amplitude Accuracy specification for frequencies from 100 kHz to 32 GHz, add ± 2 dB to the Amplitude Accuracy specification for frequencies from 32 GHz to 40 GHz.

Table A-28. Verification at 12.999995 GHz, Specification = ± 1.3 dB

Input Power	Atten Lvl	Marker 1 Reading
-30 dBm	0 dB	dBm
-30 dBm	5 dB	dBm
-30 dBm	10 dB	dBm
-30 dBm	20 dB	dBm
-2 dBm or -5 dBm	30 dB	dBm
-2 dBm or -5 dBm	40 dB	dBm
-2 dBm or -5 dBm	50 dB	dBm
-2 dBm or -5 dBm	60 dB	dBm

Table A-29. Verification at 13.0 GHz, Specification = ± 2.3 dB

Input Power	Atten Lvl	Marker 1 Reading
-30 dBm	0 dB	dBm
-30 dBm	5 dB	dBm
-30 dBm	10 dB	dBm
-30 dBm	20 dB	dBm
-2 dBm or -5 dBm	30 dB	dBm
-2 dBm or -5 dBm	40 dB	dBm
-2 dBm or -5 dBm	50 dB	dBm
-2 dBm or -5 dBm	60 dB	dBm

MS272_C Firmware Rev: _____ Operator: _____ Date: _____
 Serial Number: _____ Options: _____

Note

The listed Amplitude Accuracy specifications apply when the instrument is being verified in an environment between 20°C and 30°C after a 30 minute warm-up period. For an instrument that is not being verified in a temperature controlled environment but within a temperature range between -10°C and 50°C (-10°C and 40°C for MS2726C only) and after a 60 minute warm-up, add ± 1 dB to the Amplitude Accuracy specification for frequencies from 100 kHz to 32 GHz, add ± 2 dB to the Amplitude Accuracy specification for frequencies from 32 GHz to 40 GHz.

Table A-30. Verification at 14.0 GHz, Specification = ± 2.3 dB

Input Power	Atten Lvl	Marker 1 Reading
-30 dBm	0 dB	dBm
-30 dBm	5 dB	dBm
-30 dBm	10 dB	dBm
-30 dBm	20 dB	dBm
-2 dBm or -5 dBm	30 dB	dBm
-2 dBm or -5 dBm	40 dB	dBm
-2 dBm or -5 dBm	50 dB	dBm
-2 dBm or -5 dBm	60 dB	dBm

Table A-31. Verification at 15.0 GHz, Specification = ± 2.3 dB

Input Power	Atten Lvl	Marker 1 Reading
-30 dBm	0 dB	dBm
-30 dBm	5 dB	dBm
-30 dBm	10 dB	dBm
-30 dBm	20 dB	dBm
-2 dBm or -5 dBm	30 dB	dBm
-2 dBm or -5 dBm	40 dB	dBm
-2 dBm or -5 dBm	50 dB	dBm
-2 dBm or -5 dBm	60 dB	dBm

MS272_C Firmware Rev: _____ Operator: _____ Date: _____
 Serial Number: _____ Options: _____

Note

The listed Amplitude Accuracy specifications apply when the instrument is being verified in an environment between 20°C and 30°C after a 30 minute warm-up period. For an instrument that is not being verified in a temperature controlled environment but within a temperature range between -10°C and 50°C (-10°C and 40°C for MS2726C only) and after a 60 minute warm-up, add ± 1 dB to the Amplitude Accuracy specification for frequencies from 100 kHz to 32 GHz, add ± 2 dB to the Amplitude Accuracy specification for frequencies from 32 GHz to 40 GHz.

Table A-32. Verification at 16.0 GHz, Specification = ± 2.3 dB

Input Power	Atten Lvl	Marker 1 Reading
-30 dBm	0 dB	dBm
-30 dBm	5 dB	dBm
-30 dBm	10 dB	dBm
-30 dBm	20 dB	dBm
-2 dBm or -5 dBm	30 dB	dBm
-2 dBm or -5 dBm	40 dB	dBm
-2 dBm or -5 dBm	50 dB	dBm
-2 dBm or -5 dBm	60 dB	dBm

Table A-33. Verification at 17.0 GHz, Specification = ± 2.3 dB

Input Power	Atten Lvl	Marker 1 Reading
-30 dBm	0 dB	dBm
-30 dBm	5 dB	dBm
-30 dBm	10 dB	dBm
-30 dBm	20 dB	dBm
-2 dBm or -5 dBm	30 dB	dBm
-2 dBm or -5 dBm	40 dB	dBm
-2 dBm or -5 dBm	50 dB	dBm
-2 dBm or -5 dBm	60 dB	dBm

MS272_C Firmware Rev: _____ Operator: _____ Date: _____
 Serial Number: _____ Options: _____

Note

The listed Amplitude Accuracy specifications apply when the instrument is being verified in an environment between 20°C and 30°C after a 30 minute warm-up period. For an instrument that is not being verified in a temperature controlled environment but within a temperature range between -10°C and 50°C (-10°C and 40°C for MS2726C only) and after a 60 minute warm-up, add ± 1 dB to the Amplitude Accuracy specification for frequencies from 100 kHz to 32 GHz, add ± 2 dB to the Amplitude Accuracy specification for frequencies from 32 GHz to 40 GHz.

Table A-34. Verification at 18.0 GHz, Specification = ± 2.3 dB

Input Power	Atten Lvl	Marker 1 Reading
-30 dBm	0 dB	dBm
-30 dBm	5 dB	dBm
-30 dBm	10 dB	dBm
-30 dBm	20 dB	dBm
-2 dBm or -5 dBm	30 dB	dBm
-2 dBm or -5 dBm	40 dB	dBm
-2 dBm or -5 dBm	50 dB	dBm
-2 dBm or -5 dBm	60 dB	dBm

Table A-35. Verification at 19.0 GHz, Specification = ± 2.3 dB

Input Power	Atten Lvl	Marker 1 Reading
-30 dBm	0 dB	dBm
-30 dBm	5 dB	dBm
-30 dBm	10 dB	dBm
-30 dBm	20 dB	dBm
-2 dBm or -5 dBm	30 dB	dBm
-2 dBm or -5 dBm	40 dB	dBm
-2 dBm or -5 dBm	50 dB	dBm
-2 dBm or -5 dBm	60 dB	dBm

MS272_C Firmware Rev: _____ Operator: _____ Date: _____
 Serial Number: _____ Options: _____

Note

The listed Amplitude Accuracy specifications apply when the instrument is being verified in an environment between 20°C and 30°C after a 30 minute warm-up period. For an instrument that is not being verified in a temperature controlled environment but within a temperature range between -10°C and 50°C (-10°C and 40°C for MS2726C only) and after a 60 minute warm-up, add ± 1 dB to the Amplitude Accuracy specification for frequencies from 100 kHz to 32 GHz, add ± 2 dB to the Amplitude Accuracy specification for frequencies from 32 GHz to 40 GHz.

Table A-36. Verification at 19.999995 GHz, Specification = ± 2.3 dB

Input Power	Atten Lvl	Marker 1 Reading
-30 dBm	0 dB	dBm
-30 dBm	5 dB	dBm
-30 dBm	10 dB	dBm
-30 dBm	20 dB	dBm
-2 dBm or -5 dBm	30 dB	dBm
-2 dBm or -5 dBm	40 dB	dBm
-2 dBm or -5 dBm	50 dB	dBm
-2 dBm or -5 dBm	60 dB	dBm

Table A-37. Verification at 20.0 GHz, Specification = ± 2.3 dB

Input Power	Atten Lvl	Marker 1 Reading
-30 dBm	0 dB	dBm
-30 dBm	5 dB	dBm
-30 dBm	10 dB	dBm
-30 dBm	20 dB	dBm
-2 dBm or -5 dBm	30 dB	dBm
-2 dBm or -5 dBm	40 dB	dBm
-2 dBm or -5 dBm	50 dB	dBm
-2 dBm or -5 dBm	60 dB	dBm

MS272_C Firmware Rev: _____ Operator: _____ Date: _____
 Serial Number: _____ Options: _____

Note

The listed Amplitude Accuracy specifications apply when the instrument is being verified in an environment between 20°C and 30°C after a 30 minute warm-up period. For an instrument that is not being verified in a temperature controlled environment but within a temperature range between -10°C and 50°C (-10°C and 40°C for MS2726C only) and after a 60 minute warm-up, add ± 1 dB to the Amplitude Accuracy specification for frequencies from 100 kHz to 32 GHz, add ± 2 dB to the Amplitude Accuracy specification for frequencies from 32 GHz to 40 GHz.

Table A-38. Verification at 21.0 GHz, Specification = ± 2.3 dB

Input Power	Atten Lvl	Marker 1 Reading
-30 dBm	0 dB	dBm
-30 dBm	5 dB	dBm
-30 dBm	10 dB	dBm
-30 dBm	20 dB	dBm
-5 dBm	30 dB	dBm
-5 dBm	40 dB	dBm
-5 dBm	50 dB	dBm
-5 dBm	60 dB	dBm

Table A-39. Verification at 22.0 GHz, Specification = ± 2.3 dB

Input Power	Atten Lvl	Marker 1 Reading
-30 dBm	0 dB	dBm
-30 dBm	5 dB	dBm
-30 dBm	10 dB	dBm
-30 dBm	20 dB	dBm
-5 dBm	30 dB	dBm
-5 dBm	40 dB	dBm
-5 dBm	50 dB	dBm
-5 dBm	60 dB	dBm

MS272__C Firmware Rev: _____ Operator: _____ Date: _____
 Serial Number: _____ Options: _____

Note

The listed Amplitude Accuracy specifications apply when the instrument is being verified in an environment between 20°C and 30°C after a 30 minute warm-up period. For an instrument that is not being verified in a temperature controlled environment but within a temperature range between -10°C and 50°C (-10°C and 40°C for MS2726C only) and after a 60 minute warm-up, add ± 1 dB to the Amplitude Accuracy specification for frequencies from 100 kHz to 32 GHz, add ± 2 dB to the Amplitude Accuracy specification for frequencies from 32 GHz to 40 GHz.

Table A-40. Verification at 23.0 GHz, Specification = ± 2.3 dB

Input Power	Atten Lvl	Marker 1 Reading
-30 dBm	0 dB	dBm
-30 dBm	5 dB	dBm
-30 dBm	10 dB	dBm
-30 dBm	20 dB	dBm
-5 dBm	30 dB	dBm
-5 dBm	40 dB	dBm
-5 dBm	50 dB	dBm
-5 dBm	60 dB	dBm

Table A-41. Verification at 24.0 GHz, Specification = ± 2.3 dB

Input Power	Atten Lvl	Marker 1 Reading
-30 dBm	0 dB	dBm
-30 dBm	5 dB	dBm
-30 dBm	10 dB	dBm
-30 dBm	20 dB	dBm
-5 dBm	30 dB	dBm
-5 dBm	40 dB	dBm
-5 dBm	50 dB	dBm
-5 dBm	60 dB	dBm

MS272_C Firmware Rev: _____ Operator: _____ Date: _____
 Serial Number: _____ Options: _____

Note

The listed Amplitude Accuracy specifications apply when the instrument is being verified in an environment between 20°C and 30°C after a 30 minute warm-up period. For an instrument that is not being verified in a temperature controlled environment but within a temperature range between -10°C and 50°C (-10°C and 40°C for MS2726C only) and after a 60 minute warm-up, add ± 1 dB to the Amplitude Accuracy specification for frequencies from 100 kHz to 32 GHz, add ± 2 dB to the Amplitude Accuracy specification for frequencies from 32 GHz to 40 GHz.

Table A-42. Verification at 25.0 GHz, Specification = ± 2.3 dB

Input Power	Atten Lvl	Marker 1 Reading
-30 dBm	0 dB	dBm
-30 dBm	5 dB	dBm
-30 dBm	10 dB	dBm
-30 dBm	20 dB	dBm
-5 dBm	30 dB	dBm
-5 dBm	40 dB	dBm
-5 dBm	50 dB	dBm
-5 dBm	60 dB	dBm

Table A-43. Verification at 26.0 GHz, Specification = ± 2.3 dB

Input Power	Atten Lvl	Marker 1 Reading
-30 dBm	0 dB	dBm
-30 dBm	5 dB	dBm
-30 dBm	10 dB	dBm
-30 dBm	20 dB	dBm
-5 dBm	30 dB	dBm
-5 dBm	40 dB	dBm
-5 dBm	50 dB	dBm
-5 dBm	60 dB	dBm

MS272__C Firmware Rev: _____ Operator: _____ Date: _____
 Serial Number: _____ Options: _____

Note

The listed Amplitude Accuracy specifications apply when the instrument is being verified in an environment between 20°C and 30°C after a 30 minute warm-up period. For an instrument that is not being verified in a temperature controlled environment but within a temperature range between -10°C and 50°C (-10°C and 40°C for MS2726C only) and after a 60 minute warm-up, add ± 1 dB to the Amplitude Accuracy specification for frequencies from 100 kHz to 32 GHz, add ± 2 dB to the Amplitude Accuracy specification for frequencies from 32 GHz to 40 GHz.

Table A-44. Verification at 27.0 GHz, Specification = ± 2.3 dB

Input Power	Atten Lvl	Marker 1 Reading
-30 dBm	0 dB	dBm
-30 dBm	5 dB	dBm
-30 dBm	10 dB	dBm
-30 dBm	20 dB	dBm
-5 dBm	30 dB	dBm
-5 dBm	40 dB	dBm
-5 dBm	50 dB	dBm
-5 dBm	60 dB	dBm

Table A-45. Verification at 28.0 GHz, Specification = ± 2.3 dB

Input Power	Atten Lvl	Marker 1 Reading
-30 dBm	0 dB	dBm
-30 dBm	5 dB	dBm
-30 dBm	10 dB	dBm
-30 dBm	20 dB	dBm
-5 dBm	30 dB	dBm
-5 dBm	40 dB	dBm
-5 dBm	50 dB	dBm
-5 dBm	60 dB	dBm

MS272_C Firmware Rev: _____ Operator: _____ Date: _____
 Serial Number: _____ Options: _____

Note

The listed Amplitude Accuracy specifications apply when the instrument is being verified in an environment between 20°C and 30°C after a 30 minute warm-up period. For an instrument that is not being verified in a temperature controlled environment but within a temperature range between -10°C and 50°C (-10°C and 40°C for MS2726C only) and after a 60 minute warm-up, add ± 1 dB to the Amplitude Accuracy specification for frequencies from 100 kHz to 32 GHz, add ± 2 dB to the Amplitude Accuracy specification for frequencies from 32 GHz to 40 GHz.

Table A-46. Verification at 29.0 GHz, Specification = ± 2.3 dB

Input Power	Atten Lvl	Marker 1 Reading
-30 dBm	0 dB	dBm
-30 dBm	5 dB	dBm
-30 dBm	10 dB	dBm
-30 dBm	20 dB	dBm
-5 dBm	30 dB	dBm
-5 dBm	40 dB	dBm
-5 dBm	50 dB	dBm
-5 dBm	60 dB	dBm

Table A-47. Verification at 30.0 GHz, Specification = ± 2.3 dB

Input Power	Atten Lvl	Marker 1 Reading
-30 dBm	0 dB	dBm
-30 dBm	5 dB	dBm
-30 dBm	10 dB	dBm
-30 dBm	20 dB	dBm
-5 dBm	30 dB	dBm
-5 dBm	40 dB	dBm
-5 dBm	50 dB	dBm
-5 dBm	60 dB	dBm

MS272__C Firmware Rev: _____ Operator: _____ Date: _____
 Serial Number: _____ Options: _____

Note

The listed Amplitude Accuracy specifications apply when the instrument is being verified in an environment between 20°C and 30°C after a 30 minute warm-up period. For an instrument that is not being verified in a temperature controlled environment but within a temperature range between -10°C and 50°C (-10°C and 40°C for MS2726C only) and after a 60 minute warm-up, add ± 1 dB to the Amplitude Accuracy specification for frequencies from 100 kHz to 32 GHz, add ± 2 dB to the Amplitude Accuracy specification for frequencies from 32 GHz to 40 GHz.

Table A-48. Verification at 31.0 GHz, Specification = ± 2.3 dB

Input Power	Atten Lvl	Marker 1 Reading
-30 dBm	0 dB	dBm
-30 dBm	5 dB	dBm
-30 dBm	10 dB	dBm
-30 dBm	20 dB	dBm
-5 dBm	30 dB	dBm
-5 dBm	40 dB	dBm
-5 dBm	50 dB	dBm
-5 dBm	60 dB	dBm

Table A-49. Verification at 31.999995 GHz, Specification = ± 2.3 dB

Input Power	Atten Lvl	Marker 1 Reading
-30 dBm	0 dB	dBm
-30 dBm	5 dB	dBm
-30 dBm	10 dB	dBm
-30 dBm	20 dB	dBm
-5 dBm	30 dB	dBm
-5 dBm	40 dB	dBm
-5 dBm	50 dB	dBm
-5 dBm	60 dB	dBm

MS272_C Firmware Rev: _____ Operator: _____ Date: _____
 Serial Number: _____ Options: _____

Note

The listed Amplitude Accuracy specifications apply when the instrument is being verified in an environment between 20°C and 30°C after a 30 minute warm-up period. For an instrument that is not being verified in a temperature controlled environment but within a temperature range between -10°C and 50°C (-10°C and 40°C for MS2726C only) and after a 60 minute warm-up, add ± 1 dB to the Amplitude Accuracy specification for frequencies from 100 kHz to 32 GHz, add ± 2 dB to the Amplitude Accuracy specification for frequencies from 32 GHz to 40 GHz.

Table A-50. Verification at 32.0 GHz, Specification = ± 2.3 dB

Input Power	Atten Lvl	Marker 1 Reading
-30 dBm	0 dB	dBm
-30 dBm	5 dB	dBm
-30 dBm	10 dB	dBm
-30 dBm	20 dB	dBm
-5 dBm	30 dB	dBm
-5 dBm	40 dB	dBm
-5 dBm	50 dB	dBm
-5 dBm	60 dB	dBm

Table A-51. Verification at 33.0 GHz, Specification = ± 2.3 dB

Input Power	Atten Lvl	Marker 1 Reading
-30 dBm	0 dB	dBm
-30 dBm	5 dB	dBm
-30 dBm	10 dB	dBm
-30 dBm	20 dB	dBm
-5 dBm	30 dB	dBm
-5 dBm	40 dB	dBm
-5 dBm	50 dB	dBm
-5 dBm	60 dB	dBm

MS272__C Firmware Rev: _____ Operator: _____ Date: _____
 Serial Number: _____ Options: _____

Note

The listed Amplitude Accuracy specifications apply when the instrument is being verified in an environment between 20°C and 30°C after a 30 minute warm-up period. For an instrument that is not being verified in a temperature controlled environment but within a temperature range between -10°C and 50°C (-10°C and 40°C for MS2726C only) and after a 60 minute warm-up, add ± 1 dB to the Amplitude Accuracy specification for frequencies from 100 kHz to 32 GHz, add ± 2 dB to the Amplitude Accuracy specification for frequencies from 32 GHz to 40 GHz.

Table A-52. Verification at 34.0 GHz, Specification = ± 2.3 dB

Input Power	Atten Lvl	Marker 1 Reading
-30 dBm	0 dB	dBm
-30 dBm	5 dB	dBm
-30 dBm	10 dB	dBm
-30 dBm	20 dB	dBm
-5 dBm	30 dB	dBm
-5 dBm	40 dB	dBm
-5 dBm	50 dB	dBm
-5 dBm	60 dB	dBm

Table A-53. Verification at 35.0 GHz, Specification = ± 2.3 dB

Input Power	Atten Lvl	Marker 1 Reading
-30 dBm	0 dB	dBm
-30 dBm	5 dB	dBm
-30 dBm	10 dB	dBm
-30 dBm	20 dB	dBm
-5 dBm	30 dB	dBm
-5 dBm	40 dB	dBm
-5 dBm	50 dB	dBm
-5 dBm	60 dB	dBm

MS272_C Firmware Rev: _____ Operator: _____ Date: _____
 Serial Number: _____ Options: _____

Note

The listed Amplitude Accuracy specifications apply when the instrument is being verified in an environment between 20°C and 30°C after a 30 minute warm-up period. For an instrument that is not being verified in a temperature controlled environment but within a temperature range between -10°C and 50°C (-10°C and 40°C for MS2726C only) and after a 60 minute warm-up, add ± 1 dB to the Amplitude Accuracy specification for frequencies from 100 kHz to 32 GHz, add ± 2 dB to the Amplitude Accuracy specification for frequencies from 32 GHz to 40 GHz.

Table A-54. Verification at 36.0 GHz, Specification = ± 2.3 dB

Input Power	Atten Lvl	Marker 1 Reading
-30 dBm	0 dB	dBm
-30 dBm	5 dB	dBm
-30 dBm	10 dB	dBm
-30 dBm	20 dB	dBm
-5 dBm	30 dB	dBm
-5 dBm	40 dB	dBm
-5 dBm	50 dB	dBm
-5 dBm	60 dB	dBm

Table A-55. Verification at 37.0 GHz, Specification = ± 2.3 dB

Input Power	Atten Lvl	Marker 1 Reading
-30 dBm	0 dB	dBm
-30 dBm	5 dB	dBm
-30 dBm	10 dB	dBm
-30 dBm	20 dB	dBm
-5 dBm	30 dB	dBm
-5 dBm	40 dB	dBm
-5 dBm	50 dB	dBm
-5 dBm	60 dB	dBm

MS272__C Firmware Rev: _____ Operator: _____ Date: _____
 Serial Number: _____ Options: _____

Note

The listed Amplitude Accuracy specifications apply when the instrument is being verified in an environment between 20°C and 30°C after a 30 minute warm-up period. For an instrument that is not being verified in a temperature controlled environment but within a temperature range between -10°C and 50°C (-10°C and 40°C for MS2726C only) and after a 60 minute warm-up, add ± 1 dB to the Amplitude Accuracy specification for frequencies from 100 kHz to 32 GHz, add ± 2 dB to the Amplitude Accuracy specification for frequencies from 32 GHz to 40 GHz.

Table A-56. Verification at 38.0 GHz, Specification = ± 2.3 dB

Input Power	Atten Lvl	Marker 1 Reading
-30 dBm	0 dB	dBm
-30 dBm	5 dB	dBm
-30 dBm	10 dB	dBm
-30 dBm	20 dB	dBm
-5 dBm	30 dB	dBm
-5 dBm	40 dB	dBm
-5 dBm	50 dB	dBm
-5 dBm	60 dB	dBm

Table A-57. Verification at 39.0 GHz, Specification = ± 2.3 dB

Input Power	Atten Lvl	Marker 1 Reading
-30 dBm	0 dB	dBm
-30 dBm	5 dB	dBm
-30 dBm	10 dB	dBm
-30 dBm	20 dB	dBm
-5 dBm	30 dB	dBm
-5 dBm	40 dB	dBm
-5 dBm	50 dB	dBm
-5 dBm	60 dB	dBm

MS272_C Firmware Rev: _____ Operator: _____ Date: _____
 Serial Number: _____ Options: _____

Note

The listed Amplitude Accuracy specifications apply when the instrument is being verified in an environment between 20°C and 30°C after a 30 minute warm-up period. For an instrument that is not being verified in a temperature controlled environment but within a temperature range between -10°C and 50°C (-10°C and 40°C for MS2726C only) and after a 60 minute warm-up, add ± 1 dB to the Amplitude Accuracy specification for frequencies from 100 kHz to 32 GHz, add ± 2 dB to the Amplitude Accuracy specification for frequencies from 32 GHz to 40 GHz.

Table A-58. Verification at 40.0 GHz, Specification = ± 2.3 dB

Input Power	Atten Lvl	Marker 1 Reading
-30 dBm	0 dB	dBm
-30 dBm	5 dB	dBm
-30 dBm	10 dB	dBm
-30 dBm	20 dB	dBm
-5 dBm	30 dB	dBm
-5 dBm	40 dB	dBm
-5 dBm	50 dB	dBm
-5 dBm	60 dB	dBm

MS272_C Firmware Rev: _____ Operator: _____ Date: _____
 Serial Number: _____ Options: _____

Table A-59. Spectrum Analyzer Residual Spurious (Preamp Off)

Start Freq	Stop Freq	RBW	VBW	Measured Values (Marker 1)	Specification
9 kHz	100 kHz	300 Hz	10 Hz	dBm	≤ -90 dBm
100 kHz	10 MHz	300 Hz	100 Hz	dBm	≤ -90 dBm
10 MHz	2 GHz	30 kHz	3 kHz	dBm	≤ -90 dBm
2 GHz	4 GHz	10 kHz	1 kHz	dBm	≤ -90 dBm
4 GHz	5.35 GHz	10 kHz	300 Hz	dBm	≤ -90 dBm
5.35 GHz	7.2 GHz	3 kHz	300 Hz	dBm	≤ -90 dBm
7.2 GHz	8.2 GHz	3 kHz	300 Hz	dBm	≤ -90 dBm
8.2 GHz	9 GHz	3 kHz	300 Hz	dBm	≤ -90 dBm
9 GHz	10 GHz	1 kHz	100 Hz	dBm	≤ -90 dBm
10 GHz	11.1 GHz	300 Hz	100 Hz	dBm	≤ -90 dBm
11.1 GHz	13 GHz	1 kHz	100 Hz	dBm	≤ -90 dBm
13 GHz	16.5 GHz	1 kHz	100 Hz	dBm	≤ -85 dBm
16.5 GHz	17.5 GHz	300 Hz	30 Hz	dBm	≤ -85 dBm
17.5 GHz	18.5 GHz	300 Hz	30 Hz	dBm	≤ -85 dBm
18.5 GHz	19.25 GHz	300 Hz	30 Hz	dBm	≤ -85 dBm
19.25 GHz	20 GHz	300 Hz	30 Hz	dBm	≤ -85 dBm
20.006 GHz	22 GHz	10 kHz	300 Hz	dBm	≤ -80 dBm
22 GHz	24 GHz	10 kHz	300 Hz	dBm	≤ -80 dBm
24 GHz	26 GHz	10 kHz	300 Hz	dBm	≤ -80 dBm
26 GHz	28 GHz	10 kHz	300 Hz	dBm	≤ -80 dBm
28 GHz	30 GHz	10 kHz	300 Hz	dBm	≤ -80 dBm
30 GHz	32 GHz	10 kHz	300 Hz	dBm	≤ -80 dBm
32 GHz	34 GHz	1 kHz	300 Hz	dBm	≤ -80 dBm
34 GHz	36 GHz	1 kHz	300 Hz	dBm	≤ -80 dBm
36 GHz	38 GHz	1 kHz	300 Hz	dBm	≤ -80 dBm
38 GHz	40 GHz	1 kHz	300 Hz	dBm	≤ -80 dBm
40 GHz	42 GHz	1 kHz	300 Hz	dBm	≤ -80 dBm
42 GHz	43 GHz	1 kHz	300 Hz	dBm	≤ -80 dBm

MS272_C Firmware Rev: _____ Operator: _____ Date: _____
 Serial Number: _____ Options: _____

Table A-60. Spectrum Analyzer Residual Spurious (Preamp On)

Start Freq	Stop Freq	RBW	VBW	Measured Values (Marker 1)	Specification
9 kHz	100 kHz	300 Hz	10 Hz	dBm	≤ -100 dBm
100 kHz	10 MHz	3 kHz	300 Hz	dBm	≤ -100 dBm
10 MHz	2 GHz	30 kHz	3 kHz	dBm	≤ -100 dBm
2 GHz	4 GHz	30 kHz	3 kHz	dBm	≤ -100 dBm
4 GHz	5.35 GHz	30 kHz	3 kHz	dBm	≤ -100 dBm
5.35 GHz	7.2 GHz	30 kHz	1 kHz	dBm	≤ -100 dBm
7.2 GHz	9 GHz	30 kHz	3 kHz	dBm	≤ -100 dBm
9 GHz	11.1 GHz	10 kHz	1 kHz	dBm	≤ -100 dBm
11.1 GHz	13 GHz	30 kHz	3 kHz	dBm	≤ -100 dBm
13 GHz	16.2 GHz	30 kHz	3 kHz	dBm	≤ -100 dBm
16.2 GHz	18 GHz	3 kHz	300 Hz	dBm	≤ -100 dBm
18 GHz	18.8 GHz	10 kHz	1 kHz	dBm	≤ -100 dBm
18.8 GHz	20 GHz	3 kHz	300 Hz	dBm	≤ -100 dBm
20.006 GHz	22 GHz	30 kHz	3 kHz	dBm	≤ -100 dBm
22 GHz	24 GHz	30 kHz	3 kHz	dBm	≤ -100 dBm
24 GHz	26 GHz	30 kHz	3 kHz	dBm	≤ -100 dBm
26 GHz	28 GHz	30 kHz	3 kHz	dBm	≤ -100 dBm
28 GHz	30 GHz	30 kHz	3 kHz	dBm	≤ -100 dBm
30 GHz	32 GHz	30 kHz	3 kHz	dBm	≤ -100 dBm
32 GHz	34 GHz	3 kHz	300 Hz	dBm	≤ -95 dBm
34 GHz	36 GHz	3 kHz	300 Hz	dBm	≤ -95 dBm
36 GHz	38 GHz	3 kHz	300 Hz	dBm	≤ -95 dBm
38 GHz	40 GHz	3 kHz	300 Hz	dBm	≤ -95 dBm
40 GHz	42 GHz	3 kHz	300 Hz	dBm	≤ -95 dBm
42 GHz	43 GHz	3 kHz	300 Hz	dBm	≤ -95 dBm

MS272_C Firmware Rev: _____ Operator: _____ Date: _____
 Serial Number: _____ Options: _____

Table A-61. Spectrum Analyzer DANL (Preamp On)

Frequency Start / Stop	RBW in kHz	VBW in kHz	Measured dBm (100 kHz RBW)	Calculated dBm (1 Hz RBW)	1 Hz Specification
10 MHz to 4.0 GHz	100	1	dBm	dBm	≥ -160 dBm
4.0 GHz to 9.0 GHz	100	1	dBm	dBm	≥ -156 dBm
9.0 GHz to 13 GHz	100	1	dBm	dBm	≥ -152 dBm
13 GHz to 20 GHz	100	1	dBm	dBm	≥ -145 dBm
20 GHz to 32 GHz	100	1	dBm	dBm	≥ -154 dBm
32 GHz to 40 GHz	100	1	dBm	dBm	≥ -147 dBm

Table A-62. Spectrum Analyzer DANL (Preamp Off)

Frequency Start / Stop	RBW in kHz	VBW in kHz	Measured dBm (100 kHz RBW)	Calculated dBm (1 Hz RBW)	1 Hz Specification
10 MHz to 4.0 GHz	100	1	dBm	dBm	≥ -141 dBm
4.0 GHz to 9.0 GHz	100	1	dBm	dBm	≥ -134 dBm
9.0 GHz to 13 GHz	100	1	dBm	dBm	≥ -129 dBm
13 GHz to 20 GHz	100	1	dBm	dBm	≥ -123 dBm
20 GHz to 32 GHz	100	1	dBm	dBm	≥ -134 dBm
32 GHz to 40 GHz	100	1	dBm	dBm	≥ -127 dBm

Table A-63. Spectrum Analyzer Third Order Intercept

Third Order Intercept at Center Frequency	Measured Value	Specification
2400.151 MHz	dBm	
2399.851 MHz	dBm	
Calculated TOI at 2400 MHz	dBm	$\geq +15$ dBm

MS272_C Firmware Rev: _____ Operator: _____ Date: _____
 Serial Number: _____ Options: _____

A-2 Test Records for Options Verification

Option 31 GPS Receiver

Table A-64. Option 31, GPS Receiver Frequency Accuracy

Frequency	Measured Value	Error	Specification
7 GHz	GHz	Hz	± 175 Hz (± 25 ppb) with “GPS Hi Accy”
7 GHz	GHz	Hz	± 350 Hz (± 50 ppb) with “Int Hi Accy”

Option 40, GSM/GPRS/EDGE RF Measurements

Table A-65. Option 40, At 850 MHz, -10 dBm Level, TCH Pattern (GSM)

Measurement	Measured Value	Specification
Adjusted Output Power	dB	-10 dBm ± 0.2 dB
Displayed Burst Power	dB	
Calculated Burst Power Error	dB	± 1.5 dB
Frequency Error	Hz	± 10 Hz

Table A-66. Option 40, At 850 MHz, -50 dBm Level, TCH All Pattern (GSM)

Measurement	Measured Value	Specification
Adjusted Output Power	dB	-10 dBm ± 0.2 dB
Displayed Burst Power	dB	
Calculated Burst Power Error	dB	± 1.5 dB
Frequency Error	Hz	± 10 Hz

MS272_C Firmware Rev: _____ Operator: _____ Date: _____
 Serial Number: _____ Options: _____

Option 40, GSM/GPRS/EDGE RF Measurements (Continued)

Table A-67. Option 40, At 1800 MHz, -10 dBm Level, TCH ALL Pattern (GSM)

Measurement	Measured Value	Specification
Adjusted Output Power	dB	-10 dBm \pm 0.2 dB
Displayed Burst Power	dB	
Calculated Burst Power Error	dB	\pm 1.5 dB
Frequency Error	Hz	\pm 10 Hz

Table A-68. Option 40, At 1800 MHz, -50 dBm Level, TCH Pattern (GSM)

Measurement	Measured Value	Specification
Adjusted Output Power	dB	-10 dBm \pm 0.2 dB
Displayed Burst Power	dB	
Calculated Burst Power Error	dB	\pm 1.5 dB
Frequency Error	Hz	\pm 10 Hz

Table A-69. Option 40, At 1800 MHz, -50 dBm Level, DL_MCS-9_1SLOT Pattern (EDGE)

Measurement	Measured Value	Specification
Adjusted Output Power	dB	-10 dBm \pm 0.2 dB
Displayed Burst Power	dB	
Calculated Burst Power Error	dB	\pm 1.5 dB
Frequency Error	Hz	\pm 10 Hz

Table A-70. Option 40, At 1800 MHz, -10 dBm Level, DL_MCS-9_4SLOT Pattern (EDGE)

Measurement	Measured Value	Specification
Adjusted Output Power	dB	-10 dBm \pm 0.2 dB
Displayed Burst Power	dB	
Calculated Burst Power Error	dB	\pm 1.5 dB
Frequency Error	Hz	\pm 10 Hz

MS272_C Firmware Rev: _____ Operator: _____ Date: _____
 Serial Number: _____ Options: _____

Option 40, GSM/GPRS/EDGE RF Measurements (Continued)

Table A-71. Option 40, At 850 MHz, -50 dBm Level, DL_MCS-9_4SLOT Pattern (EDGE)

Measurement	Measured Value	Specification
Adjusted Output Power	dB	-10 dBm ± 0.2 dB
Displayed Burst Power	dB	
Calculated Burst Power Error	dB	± 1.5 dB
Frequency Error	Hz	± 10 Hz

Table A-72. Option 40, At 850 MHz, -10 dBm Level, DL_MCS-9_1SLOT Pattern (EDGE)

Measurement	Measured Value	Specification
Adjusted Output Power	dB	-10 dBm ± 0.2 dB
Displayed Burst Power	dB	
Calculated Burst Power Error	dB	± 1.5 dB
Frequency Error	Hz	± 10 Hz

MS272__C Firmware Rev: _____ Operator: _____ Date: _____
 Serial Number: _____ Options: _____

Option 41, GSM/GPRS/EDGE Demodulator

Table A-73. Option 41, At 850 MHz, -10 dBm Level, TCH Pattern (GSM)

Measurement	Measured Value	Specification
Phase Err RMS (Deg)	Deg	≤ 1 Deg

Table A-74. Option 41, At 850 MHz, -50 dBm Level, TCH ALL Pattern (GSM)

Measurement	Measured Value	Specification
Phase Err RMS (Deg)	Deg	≤ 1 Deg

Table A-75. Option 41, At 1800 MHz, -10 dBm Level, TCH ALL Pattern (GSM)

Measurement	Measured Value	Specification
Phase Err RMS (Deg)	Deg	≤ 1 Deg

Table A-76. Option 41, At 1800 MHz, -50 dBm Level, TCH Pattern (GSM)

Measurement	Measured Value	Specification
Phase Err RMS (Deg)	Deg	≤ 1 Deg

Table A-77. Option 41, At 1800 MHz, -50 dBm Level, DL_MCS-9_1SLOT Pattern (EDGE)

Measurement	Measured Value	Specification
Phase Err RMS (Deg)	Deg	≤ 1 Deg

Table A-78. Option 41, At 1800 MHz, -10 dBm Level, DL_MCS-9_4SLOT Pattern (EDGE)

Measurement	Measured Value	Specification
Phase Err RMS (Deg)	Deg	≤ 1 Deg

MS272_C Firmware Rev: _____ Operator: _____ Date: _____
 Serial Number: _____ Options: _____

Option 41, GSM/GPRS/EDGE Demodulator (Continued)

Table A-79. Option 41, At 850 MHz, -50 dBm Level, DL_MCS-9_4SLOT Pattern (EDGE)

Measurement	Measured Value	Specification
Phase Err RMS (Deg)	Deg	≤ 1 Deg

Table A-80. Option 41, At 850 MHz, -10 dBm Level, DL_MCS-9_1SLOT Pattern (EDGE)

Measurement	Measured Value	Specification
Phase Err RMS (Deg)	Deg	≤ 1 Deg

MS272__C Firmware Rev: _____ Operator: _____ Date: _____
 Serial Number: _____ Options: _____

Option 42 CDMA RF Measurements

Table A-81. Option 42, At 870.03 MHz, -30 dBm Level, cdmaOne

Measurement	Measured Value	Specification
Power Meter Reading	dBm	-30 dBm \pm 0.2 dB
Channel Power Value	dBm	
Channel Power Error	dBm	\pm 1.5 dB

Table A-82. Option 42, At 1930.05 MHz, -30 dBm Level, cdmaOne

Measurement	Measured Value	Specification
Power Meter Reading	dBm	-30 dBm \pm 0.2 dB
Channel Power Value	dBm	
Channel Power Error	dBm	\pm 1.5 dB

Table A-83. Option 42, At 1930.05, -30 dBm Level, CDMA2000

Measurement	Measured Value	Specification
Power Meter Reading	dBm	-30 dBm \pm 0.2 dB
Channel Power Value	dBm	
Channel Power Error	dBm	\pm 1.5 dB

Table A-84. Option 42, At 870.03 MHz, -30 dBm Level, CDMA2000

Measurement	Measured Value	Specification
Power Meter Reading	dBm	-30 dBm \pm 0.2 dB
Channel Power Value	dBm	
Channel Power Error	dBm	\pm 1.5 dB

MS272_C Firmware Rev: _____ Operator: _____ Date: _____
 Serial Number: _____ Options: _____

Option 43 cdmaOne and CDMA2000 1xRTT Demodulator

Table A-85. Option 43, At 870.03 MHz, -30 dBm Level, cdmaOne

Measurement	Measured Value	Specification
Frequency Error	Hz	± 10 Hz
Rho		$0.99 \leq x \leq 1$
Tau	μ S	± 1 μ S

Table A-86. Option 43, At 1930.05 MHz, -30 dBm Level, cdmaOne

Measurement	Measured Value	Specification
Frequency Error	Hz	± 10 Hz
Rho		$0.99 \leq x \leq 1$
Tau	μ S	± 1 μ S

Table A-87. Option 43, At 1930.05 MHz, -30 dBm Level, CDMA2000

Measurement	Measured Value	Specification
Frequency Error	Hz	± 10 Hz
Rho		$0.99 \leq x \leq 1$
Tau	μ S	± 1 μ S

Table A-88. Option 43, At 870.03 MHz, -30 dBm Level, CDMA2000

Measurement	Measured Value	Specification
Frequency Error	Hz	± 10 Hz
Rho		$0.99 \leq x \leq 1$
Tau	μ S	± 1 μ S

MS272_C Firmware Rev: _____ Operator: _____ Date: _____
 Serial Number: _____ Options: _____

Option 44 and/or 45 and/or 65 WCDMA and HSDPA RF Measurements

Table A-89. Option 44, Sensor A and Sensor B Readings, Components Characterization

Frequency	PMA.10	PMB.10	Delta 1 ($\Delta 1$)	PMA.10C	PMA.18	ATT.18
881.5 MHz	dBm	dBm	dBm	dBm	dBm	dB

Table A-90. Option 44, Power Level Setting, Components Characterization

Frequency	MG3700A.10 Setting	MG3700A.28 Setting	PMA – 10	PMA – 20
881.5 MHz	dBm	dBm	dBm	dBm

Table A-91. Option 44, WCDMA Absolute Power Accuracy

Test Level	Measured Power	Error	Specification
+28 dBm	dBm	dB	± 1.25 dB
+10 dBm	dBm	dB	± 1.25 dB
-10 dBm	dBm	dB	± 1.25 dB
-20 dBm	dBm	dB	± 1.25 dB
Test Level	dBm	dB	± 1.25 dB

Table A-92. Option 44, WCDMA Occupied Bandwidth (OBW)

Frequency	Power Meter Reading	OBW	Specification
881.5 MHz	dBm	MHz	4.2 MHz \pm 100 kHz
1962.5 MHz	dBm	MHz	4.2 MHz \pm 100 kHz
2680.5 MHz	dBm	MHz	4.2 MHz \pm 100 kHz

MS272_C Firmware Rev: _____ Operator: _____ Date: _____
 Serial Number: _____ Options: _____

Option 44 and/or 45 and/or 65 WCDMA and HSDPA RF Measurements (Continued)

Table A-93. Option 44, WCDMA RF Channel Power Accuracy

Frequency	Power Meter Reading	Measured RF Channel Power	RF Channel Power Error	Specification
881.5 MHz	dBm	dBm	dBm	± 1.25 dBm max
1962.5 MHz	dBm	dBm	dBm	± 1.25 dBm max
2680.5 MHz	dBm	dBm	dBm	± 1.25 dBm max

Table A-94. WCDMA ACLR Accuracy

Frequency/Offset	Measured ACLR	Calculated ACLR Error	Specification
881.5 / -10 MHz			± 0.8 dB
881.5 / -5 MHz			± 0.8 dB
881.5 / 5 MHz			± 0.8 dB
881.5 / 10 MHz			± 0.8 dB
1962.5 / -10 MHz			± 0.8 dB
1962.5 / -5 MHz			± 0.8 dB
1962.5 / 5 MHz			± 0.8 dB
1962.5 / 10 MHz			± 0.8 dB
2680.5 / -10 MHz			± 1.0 dB
2680.5 / -5 MHz			± 1.0 dB
2680.5 / 5 MHz			± 1.0 dB
2680.5 / 10 MHz			± 1.0 dB

Table A-95. Option 44, HSDPA RF Channel Power Accuracy

Frequency	Power Meter Reading	Measured RF Channel Power	RF Channel Power Error	Specification
2680.5 MHz				± 1.25 dB max

MS272__C Firmware Rev: _____ Operator: _____ Date: _____
 Serial Number: _____ Options: _____

Option 44 and/or 45 and/or 65 WCDMA and HSDPA RF Measurements (Continued)

Table A-96. Option 44, HSDPA ACLR Accuracy

Frequency/Offset	Measured ACLR	Calculated ACLR Error	Specification
2680.5 / -10 MHz			± 1.0 dB
2680.5 / -5 MHz			± 1.0 dB
2680.5 / 5 MHz			± 1.0 dB
2680.5 / 10 MHz			± 1.0 dB

Table A-97. Option 45 or 65, WCDMA Error Vector Magnitude (Test Model 4)

Frequency	EVM	Specification
1962.5 MHz	%	± 2.5 %

Table A-98. Option 65, HSDPA Error Vector Magnitude (Test Model 5)

Frequency	EVM	Specification
1962.5 MHz	%	± 2.5 %

MS272_C Firmware Rev: _____ Operator: _____ Date: _____
 Serial Number: _____ Options: _____

Option 46 Fixed WiMAX RF Measurements

Table A-99. Option 46, Fixed WiMAX Channel Power Accuracy Adjusted MG3700A Level Settings

Frequency	Input Power Setting	Input Power Reading
2600.5 MHz	-15 dBm	dBm
2600.5 MHz	-50 dBm	dBm
3600.5 MHz	-15 dBm	dBm
3600.5 MHz	-50 dBm	dBm
5600.5 MHz	-15 dBm	dBm
5600.5 MHz	-50 dBm	dBm

Table A-100. Option 46, Fixed WiMAX Channel Power Accuracy

Frequency	Input Power	Measured Channel Power (RSSI)	Error	Specification
2600.5 MHz	-15 dBm	dBm	dB	± 1.5 dB
2600.5 MHz	-50 dBm	dBm	dB	± 1.5 dB
3600.5 MHz	-15 dBm	dBm	dB	± 1.5 dB
3600.5 MHz	-50 dBm	dBm	dB	± 1.5 dB
5600.5 MHz	-15 dBm	dBm	dB	± 1.5 dB
5600.5 MHz	-50 dBm	dBm	dB	± 1.5 dB

MS272__C Firmware Rev: _____ Operator: _____ Date: _____
 Serial Number: _____ Options: _____

Option 47 Fixed WiMAX Demodulator

Table A-101. Option 47, Fixed WiMAX Residual EVM

Frequency	Power	BW	EVM (RMS)	Specification
2600.5 MHz	-15 dBm	10 MHz	%	≤ 3.5 %
2600.5 MHz	-50 dBm	10 MHz	%	≤ 3.5 %
3600.5 MHz	-15 dBm	10 MHz	%	≤ 3.5 %
3600.5 MHz	-50 dBm	10 MHz	%	≤ 3.5 %
5600.5 MHz	-15 dBm	10 MHz	%	≤ 3.5 %
5600.5 MHz	-50 dBm	10 MHz	%	≤ 3.5 %

Table A-102. Option 47, Fixed WiMAX Frequency Error

Frequency	Power	Frequency Error	Specification
2600.5 MHz	-50 dBm	Hz	± 10 Hz
5600.5 MHz	-50 dBm	Hz	± 10 Hz

Option 60 or 61, TDSCDMA Signal Analyzer Option Verification

Table A-103. Option 60 or 61, TDSCDMA (at 2010 MHz, -45 dBm Level)

Measurement Type	Measured Value	Specification
Power Meter Reading	dBm	-45 dBm ± 0.5 dB
Displayed Channel Power	dBm	
Calculated Channel Power Error	dB	± 1.5 dB
EVM	%	< 3 % typical
Frequency Error	Hz	± 20 Hz
Tau	μs	± 0.2 μs

MS272_C Firmware Rev: _____ Operator: _____ Date: _____
 Serial Number: _____ Options: _____

Option 62, EVDO RF Measurements

Table A-104. Option 62, At 870.03 MHz, -50 dBm Level, 921.6 kps 8PSK Modulation

Measurement	Measured Value	Specification
Power Meter Reading	dBm	-50 dBm \pm 0.2 dB
MS272xC Reading	dBm	
Calculated Channel Power Error	dB	\pm 1.5 dB

Table A-105. Option 62, At 1930.05 MHz, 0 dBm Level, 38.4 kps QPSK Modulation

Measurement	Measured Value	Specification
Power Meter Reading	dBm	0 dBm \pm 0.2 dB
MS272xC Reading	dBm	
Calculated Channel Power Error	dB	\pm 1.5 dB

Table A-106. Option 62, At 1930.05 MHz, -50 dBm Level, 2457.6 kps 16QAM Modulation

Measurement	Measured Value	Specification
Power Meter Reading	dBm	-50 dBm \pm 0.2 dB
MS272xC Reading	dBm	
Calculated Channel Power Error	dB	\pm 1.5 dB

Table A-107. Option 62, At 1930.05 MHz, -50 dBm Level, Idle Slot

Measurement	Measured Value	Specification
Power Meter Reading	dBm	-50 dBm \pm 0.2 dB
MS272xC Reading	dBm	
Calculated Channel Power Error	dB	\pm 1.5 dB

MS272__C Firmware Rev: _____ Operator: _____ Date: _____
 Serial Number: _____ Options: _____

Option 62, EVDO RF Measurements (Continued)

Table A-108. Option 62, At 870.03 MHz, -10 dBm Level, Idle Slot

Measurement	Measured Value	Specification
Power Meter Reading	dBm	-10 dBm \pm 0.2 dB
MS272xC Reading	dBm	
Calculated Channel Power Error	dB	\pm 1.5 dB

Option 63 EVDO Demodulator

Table A-109. Option 63, At 870.03 MHz, -50 dBm Level, 921.6 kps 8PSK Modulation

Measurement	Measured Value	Specification
Frequency Error	Hz	\pm 20 Hz
Rho Pilot		$0.99 \leq x \leq 1$
Tau	μ S	\pm 1 μ S

Table A-110. Option 63, At 1930.05 MHz, 0 dBm Level, 38.4 kps QPSK Modulation

Measurement	Measured Value	Specification
Frequency Error	Hz	\pm 20 Hz
Rho Pilot		$0.99 \leq x \leq 1$
Tau	μ S	\pm 1 μ S

MS272_C Firmware Rev: _____ Operator: _____ Date: _____
 Serial Number: _____ Options: _____

Option 63 EVDO Demodulator (Continued)

Table A-111. Option 63, At 1930.05 MHz, -50 dBm Level, 2457.6 kps 16QAM Modulation

Measurement	Measured Value	Specification
Frequency Error	Hz	± 20 Hz
Rho Pilot		$0.99 \leq x \leq 1$
Tau	μ s	± 1 μ s

Table A-112. Option 63, At 1930.05 MHz, -50 dBm Level, Idle Slot

Measurement	Measured Value	Specification
Frequency Error	Hz	± 20 Hz
Rho Pilot		$0.99 \leq x \leq 1$
Tau	μ s	± 1 μ s

Table A-113. Option 63, At 870.03 MHz, -10 dBm Level, Idle Slot

Measurement	Measured Value	Specification
Frequency Error	Hz	± 20 Hz
Rho Pilot		$0.99 \leq x \leq 1$
Tau	μ s	± 1 μ s

MS272__C Firmware Rev: _____ Operator: _____ Date: _____
 Serial Number: _____ Options: _____

Option 66 Mobile WiMAX RF Measurements

Channel Power Accuracy (10 MHz Bandwidth and 10 ms Frame Length)

Table A-114. Option 66, Mobile WiMAX Channel Power Accuracy Power Error (2600.5 MHz and –15.0 dBm)

Measurement	Measured Value	Specification
Power Meter Reading	dBm	–15 dBm ± 0.2 dB
MS272xC Reading	dBm	
Calculated Channel Power Error	dB	± 1.5 dB

Table A-115. Option 66, Mobile WiMAX Channel Power Accuracy Power Error (2600.5 MHz and –50.0 dBm)

Measurement	Measured Value	Specification
Power Meter Reading	dBm	–50 dBm ± 0.2 dB
MS272xC Reading	dBm	
Calculated Channel Power Error	dB	± 1.5 dB

Table A-116. Option 66, Mobile WiMAX Channel Power Accuracy Power Error (3600.5 MHz and –15.0 dBm)

Measurement	Measured Value	Specification
Power Meter Reading	dBm	–15 dBm ± 0.2 dB
MS272xC Reading	dBm	
Calculated Channel Power Error	dB	± 1.5 dB

Table A-117. Option 66, Mobile WiMAX Channel Power Accuracy Power Error (3600.5 MHz and –50.0 dBm)

Measurement	Measured Value	Specification
Power Meter Reading	dBm	–50 dBm ± 0.2 dB
MS272xC Reading	dBm	
Calculated Channel Power Error	dB	± 1.5 dB

MS272_C Firmware Rev: _____ Operator: _____ Date: _____
 Serial Number: _____ Options: _____

Option 66 Mobile WiMAX RF Measurements (Continued)

Channel Power Accuracy (5 MHz Bandwidth and 5 ms Frame Length)

Table A-118. Option 66, Mobile WiMAX Channel Power Accuracy Power Error (2600.5 MHz and -15.0 dBm)

Measurement	Measured Value	Specification
Power Meter Reading	dBm	-15 dBm ± 0.2 dB
MS272xC Reading	dBm	
Calculated Channel Power Error	dB	± 1.5 dB

Table A-119. Option 66, Mobile WiMAX Channel Power Accuracy Power Error (2600.5 MHz and -50.0 dBm)

Measurement	Measured Value	Specification
Power Meter Reading	dBm	-50 dBm ± 0.2 dB
MS272xC Reading	dBm	
Calculated Channel Power Error	dB	± 1.5 dB

Table A-120. Option 66, Mobile WiMAX Channel Power Accuracy Power Error (3600.5 MHz and -15.0 dBm)

Measurement	Measured Value	Specification
Power Meter Reading	dBm	-15 dBm ± 0.2 dB
MS272xC Reading	dBm	
Calculated Channel Power Error	dB	± 1.5 dB

Table A-121. Option 66, Mobile WiMAX Channel Power Accuracy Power Error (3600.5 MHz and -50.0 dBm)

Measurement	Measured Value	Specification
Power Meter Reading	dBm	-50 dBm ± 0.2 dB
MS272xC Reading	dBm	
Calculated Channel Power Error	dB	± 1.5 dB

MS272_C Firmware Rev: _____ Operator: _____ Date: _____
 Serial Number: _____ Options: _____

Option 67 Mobile WiMAX Demodulator

Table A-122. Option 67, Mobile WiMAX Residual EVM (10 MHz Bandwidth and 10 ms Frame Length)

Frequency	Power	BW	EVM (rms)	Specification
2600.5 MHz	-15 dBm	10 MHz	%	≤ 3.0 %
2600.5 MHz	-50 dBm	10 MHz	%	≤ 3.0 %
3600.5 MHz	-15 dBm	10 MHz	%	≤ 3.0 %
3600.5 MHz	-50 dBm	10 MHz	%	≤ 3.0 %

Table A-123. Option 67, Mobile WiMAX Frequency Error (10 MHz Bandwidth and 10 ms Frame Length)

Frequency	Power	Frequency Error	Specification
2600.5 MHz	-50 dBm	Hz	± 10 Hz
3600.5 MHz	-50 dBm	Hz	± 10 Hz

Table A-124. Option 67, Mobile WiMAX Residual EVM (5 MHz Bandwidth and 5 ms Frame Length)

Frequency	Power	BW	EVM (rms)	Specification
2600.5 MHz	-15 dBm	10 MHz	%	≤ 3.0 %
2600.5 MHz	-50 dBm	10 MHz	%	≤ 3.0 %
3600.5 MHz	-15 dBm	10 MHz	%	≤ 3.0 %
3600.5 MHz	-50 dBm	10 MHz	%	≤ 3.0 %

Table A-125. Option 67, Mobile WiMAX Frequency Error (5 MHz Bandwidth and 5 ms Frame Length)

Frequency	Power	Frequency Error	Specification
2600.5 MHz	-50 dBm	Hz	± 10 Hz
3600.5 MHz	-50 dBm	Hz	± 10 Hz

MS272_C Firmware Rev: _____ Operator: _____ Date: _____
 Serial Number: _____ Options: _____

Option 541 and 543 LTE Measurements

Table A-126. Option 541 and 543, LTE Channel Power Accuracy

Frequency (MHz)	Input Power (dBm)	Measured Channel Power	Error	Specification
For Units with Option 541 Installed, Pattern E-TM_1-1_10M				
750	-10	dBm	dB	± 1.5 dB
750	-50	dBm	dB	± 1.5 dB
2150	-10	dBm	dB	± 1.5 dB
2150	-50	dBm	dB	± 1.5 dB
For Units with Option 543 Installed, Pattern E-TM_1-1_20M				
750	-10	dBm	dB	± 1.5 dB
750	-50	dBm	dB	± 1.5 dB
2150	-10	dBm	dB	± 1.5 dB
2150	-50	dBm	dB	± 1.5 dB

MS272_C Firmware Rev: _____ Operator: _____ Date: _____
 Serial Number: _____ Options: _____

Option 542 and 543, LTE Measurements

Table A-127. Option 542, LTE Residual EVM and Frequency Accuracy

Measurement	Measured Value	Specification
For Units with Option 542 Installed, Pattern E-TM_1-1_10M		
750 MHz @ -10 dBm		
Frequency Error	Hz	± 10 Hz
EVM (rms)	%	< 2.5 % typical
750 MHz @ -50 dBm		
Frequency Error	Hz	± 10 Hz
EVM (rms)	%	< 2.5 % typical
2150 MHz @ -10 dBm		
Frequency Error	Hz	± 10 Hz
EVM (rms)	%	< 2.5 % typical
2150 MHz @ -50 dBm		
Frequency Error	Hz	± 10 Hz
EVM (rms)	%	< 2.5 % typical
For Units with Option 543 Installed, Pattern E-TM_1-1_20M		
750 MHz @ -10 dBm		
Frequency Error	Hz	± 10 Hz
EVM (rms)	%	< 2.5 % typical
750 MHz @ -50 dBm		
Frequency Error	Hz	± 10 Hz
EVM (rms)	%	< 2.5 % typical
2150 MHz @ -10 dBm		
Frequency Error	Hz	± 10 Hz
EVM (rms)	%	< 2.5 % typical
2150 MHz @ -50 dBm		
Frequency Error	Hz	± 10 Hz
EVM (rms)	%	< 2.5 % typical

Anritsu



Anritsu prints on recycled paper with vegetable soybean oil ink.

www.valuetronics.com

Anritsu Company
490 Jarvis Drive
Morgan Hill, CA 95037-2809
USA
<http://www.anritsu.com>