

ePower

Programmable DC Power Supplies

... Models Available with Embedded Ethernet



Sales
Support
Service

Reliability. Engineered.
(971) 244-8200 help@r-source.com

Low Noise Linear Power Supplies
Mid-Power Switch Mode Rackmount
High-Power Switch Mode Cabinet Mount

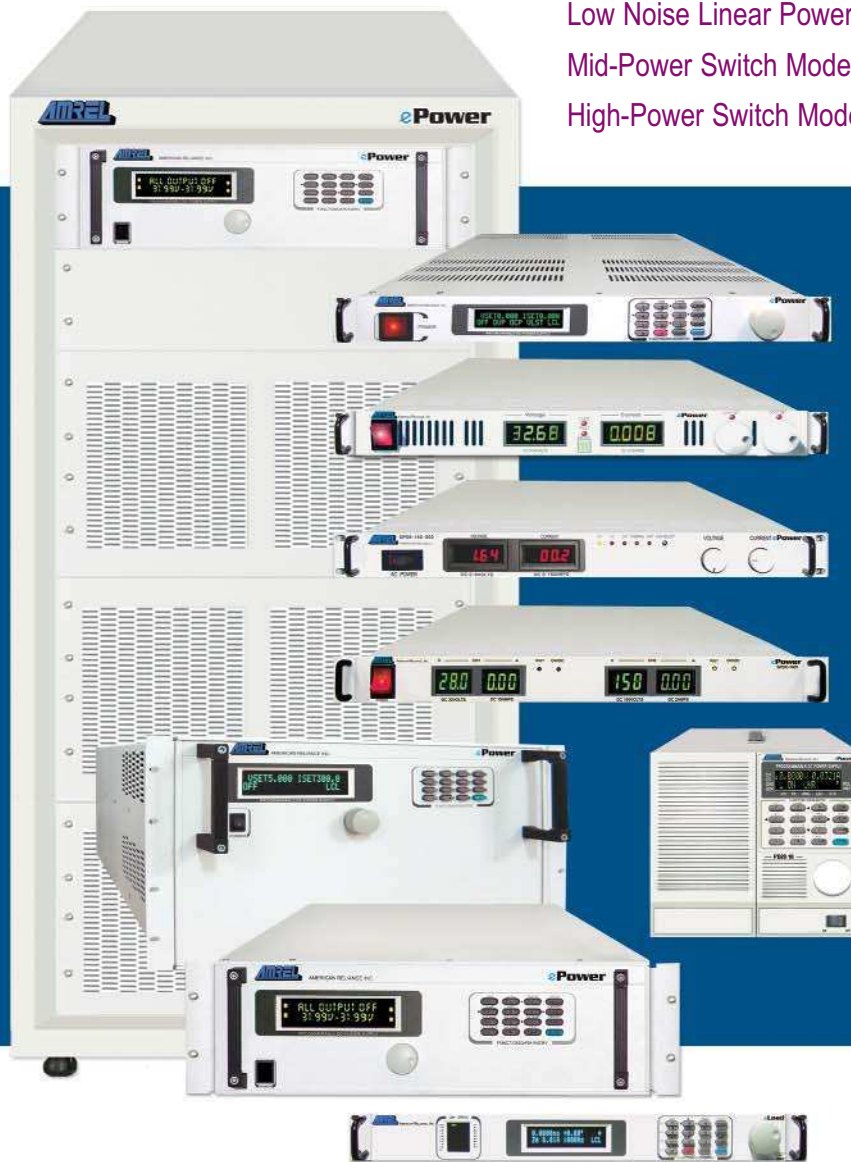

www.valuetronics.com



AMERICAN RELIANCE, INC.

TABLE OF CONTENTS

Why ePower	1
ePower Applications	2
ePower Features Guide	3
Programmable 1.2kW/1.5kW Switch Mode Power Supplies (SPS Series) Features	4, 5
Programmable 1.2kW/1.5kW Switch Mode Power Supplies (SPS Series) Datasheets	6-11
Programmable 1.2kW/1.5kW Switch Mode Power Supplies (SPS Series) Selector Guide	12
Programmable Dual Switch Mode Power Supplies (SPD Models) Features	13
Programmable Dual Switch Mode Power Supplies (SPD Models) Datasheets	14, 15, 16, 17
Programmable Dual Switch Mode Power Supplies (SPD Models) Selector Guide	18
Programmable 3.3kW+ Switch Mode Power Supplies (SPS & HPS Series) Features	19
Programmable 3.3kW+ Switch Mode Power Supplies (SPS & HPS Series) Datasheets	20-23
Programmable 3.3kW+ Switch Mode Power Supplies (SPS & HPS Series) Selector Guide	24
Programmable Linear Power Supply (PD Series) Features	25
Programmable Linear Power Supply (PD Series) Datasheet	26 & 27
Programmable Linear Power Supply (PD Series) Selector Guide	28
PD Series Rack Mount Configurations	29
MCU Multiple Channel Controller Systems Network Configurations	30 & 31
Customizations and Modifications	32
Information on Requesting a Quote and Placing an Order	Inside Back Cover
Other Products Available – Overview of AMREL's eLoad Line	Outside Back Cover



SPS Series of Rack Mount, Programmable Switch Mode Power Supplies
 1.2kW-45kW, available with or without panel keypad & encoder.
 15kW+ water-cooled models available.

HPS Series of Cabinet Mount, Switch Mode Programmable High Power Supplies
 3.3kW-160kW+, 15kW+ available in air or water-cooled models.



PD Series of Programmable Linear Power Supplies
 20W-2000W+, available in rack mount and bench-top (BPD) models.

Please Note: Specifications contained in this catalog are subject to change without notification.

ePower OFFERS 50-400Hz AC INPUT FREQUENCY IN HIGH POWER RANGES

AMREL's ePower Line of High Power Switch Mode Supplies, with up to 400Hz ac input frequency, was specifically designed to address application requirements for Military and Commercial Aircraft electrical systems.



ePower OFFERS SEALED, WATER-COOLED MODELS FOR HARSH ENVIRONMENTS



- Available Models: 10kW, 15kW, 25kW, 30kW, 45kW
- Wide Selection of Voltage and Current Combinations
- Critical Components Completely Isolated from Environment
- Ideal for Electroplating or Water Treatment Applications
- Current Fed Technology Provides High Reliability

ePower THE WIDEST RANGE OF POWER SUPPLIES ON THE MARKET



LINEAR

- 20W to 2,000W
- 5V to 350V
- 0.15A to 50A

SWITCH MODE

- 1.2kW to 500kW+
- 5V to 2500V
- 2A to 7500A+

The ePower Line has a power solution for almost any application.

ePower MEETS THE TOUGHEST SPEC REQUIREMENTS WITH CUSTOM AND MODIFIED SOLUTIONS

- Industry Leading Engineering Team
- Quick Turn on Modified Standard Products
- Complete Documentation from Proposal to Acceptance
- Integration Applications Partnering



SPDC Customized Dual Channel Switch Mode
(see page 32 for more examples of customizations)

NEMA ENCLOSURES PROTECT THE ePower SUPPLY FROM THE HARSHTEST ENVIRONMENTS

- Standard NEMA 3R Weatherized Enclosures
- Indoor & Outdoor Environments
- Protection Against Harsh Environments
- Dirt, Rain, Sleet, Snow
- External Formation of Ice



ePower AMREL's MCU NETWORK



MCU Controller = Unlimited Expansion

- Complete Remote Access & Control
- Embedded Ethernet or RS-485 Interface
- One MCU Controls 8 Power Supplies
- Add More MCU Controllers for Unlimited Expansion

ePower CURRENT FED TECHNOLOGY FOR INCREASED RELIABILITY

- Unlike voltage fed converters, ePowers current fed converters eliminate fast rising current spikes or magnetic core saturation.
- Operate with the robustness of an SCR based power supply, but at high frequency.
- Includes an additional power processing stage, which can be used for control and an enhanced system

* Please note this feature is available with the SPS3.3kW and up models and the HPS Series

Sampling of Applications Utilizing AMREL's ePower Supplies

Product	Military/ATE Test Systems	Burn-in	Manufacturing	R&D/Lab Test	General ATE	Test and Measurement	Medical	Magnetic Coils	dc Motors	RF Amplifiers	Electro-Deposition	Laser Diode	Automotive Electronics	Power Supply/Battery Testing	Semiconductor/Component
SPS (1.2KW)	X	X	X	X	X	X		X	X			X	X	X	X
SPD	X	X	X	X	X	X		X	X		X	X	X	X	X
SPS (3.3KW+)	X	X	X	X	X	X		X	X		X	X			
HPS	X	X			X		X	X		X	X				
PD	X	X	X	X	X	X	X			X	X		X	X	X

MILITARY ATE TEST SYSTEMS

AMREL's ePower programmable switch mode power supplies (SPS) are utilized extensively in military applications such as the Joint Strike Fighter (JSF) Program. Our power supply features allow easy integration and operation in ATE Systems, ranging from Avionics Testing to Maintenance Depot Stations. With its compact size, as low as 1U-high, and wide range of available interfaces, GPIB, RS-232, USB, Ethernet, and RS-485, AMREL's SPS Series has become our most popular ATE power supply. Each model within the SPS Series is ready for rack and stack environments, right out of the box. There is no need for rack mount hardware as each unit comes in a standard 19" rack width including front panel integrated mounting ears. For simple ATE integration, SCPI commands and LabVIEW /LabWindows Drivers are available.

BURN-IN TEST

Whether your requirement is for Static or Dynamic Burn-in, AMREL's ePower switch mode power supplies have the reliability and robustness to run 24/7 at full power. Programming the voltages and currents for your burn-in power supply is as simple as turning a knob, providing an analog trigger signal or sending software command via one of the available Interfaces: GPIB, RS-232, USB, or Ethernet. For bulk power requirements, AMREL has ePower units ranging from 3.3kW up to 150kW. The SPS series offers the necessary flexibility required for a wide range of burn-in applications.

MANUFACTURING TEST

AMREL's ePower line has the widest range of voltage, current, and power level options, to meet your circuit board and component testing requirements. For production line automation, all AMREL power supplies provide output sequencing programming, allowing you to quickly program your power supply to different types of test routines. Combined with a number of available control interfaces, each power supply can easily adapt to different programming environments within your manufacturing test setups. Automated tests can also be realized utilizing ePower supplies' SCPI commands, as well as LabVIEW and LabWindows drivers.

R&D/LAB TEST

AMREL's PD Series of programmable dc linear power supplies are designed for both bench-top and rack and stack environments. The PD model has a very clean output for demanding product design tests and product validation. With an Output Ripple and Noise of typically 1-3mVpp and a load regulation of 1mV and 1mA, the PD series is ideal for any low noise application.

In addition to the above applications, AMREL's ePower line of programmable linear (PD) and switch mode (SPS/HPS) power supplies are used in the following applications: General ATE, Test and Measurement, Medical, Magnetic Coils, DC Motors, RF Amplifiers, Electro-deposition, Laser Diode, and Automotive Electronics.

FEATURES GUIDE

	Output Ratings			Programming Interfaces											
	Voltage Ranges	Current Ranges	Power Ranges	Front Panel Keypad	Front Panel Control Knob(s)	RS-232	GPIB	Ethernet	USB	RS-485	External Analog Control	120Vac 50/60Hz, Single Phase	240Vac 50/60Hz, Single Phase	208Vac, 50Hz, Single Phase	3-Phase Input
SPS Switching (O-Panel Vers.)	8V-800V	1.5A-150A	1200W	N/A	S	O	O	N/A	N/A	O	S	*S	*S	N/A	N/A
SPS Switching (K-Panel Vers.)	8V-800V	1.5A-150A	1200W	S	S	S	S	S	S	N/A	N/A	*S	*S	N/A	N/A
SPS Switching (V-Panel Vers.)	8V-800V	1.5A-150A	1200W - 1500W	N/A	S	S	S	O	O	O	N/A	*S	*S	O	O
SPD Switching (Dual Channels)	8V-300V	1A-40A	360W	S	S	S	S	O	N/A	S	N/A	*S	*S	O	N/A
SPS Switching (3.3kW and Up)	5V-1000V	3A-2700A	3.3kW-30kW	S	S	S	S	O	O	N/A	S	N/A	O	N/A	S
HPS High Power Switching	10V-2500V	20A-7500A	20kW-150kW	S	S	S	S	O	O	N/A	S	N/A	O	N/A	S
PD Linear	5V-350V	0.2A-50A	20W-2000W	S	N/A	S	S	O	O	O	O	S	O	N/A	N/A

S=Standard

O=Optional

N/A=Not Available

***Note:** SPS 1.5kW models are available with a 208Vac, three phase input or 240Vac, one phase input. SPS and SPD 1.2kW models offer a choice of 120Vac or 240Vac for no additional cost. SPS 1.5kW models range from 12V-600V and 2.5A-125A.

PROGRAMMABLE SWITCH MODE POWER SUPPLIES

Common Features for ALL SPS 1.2kW and 1.5kW Models

- Automatic Constant Voltage/Constant Current Mode Crossover
- Multiple units can be connected in parallel or in series to provide increased current or voltage
- Output Voltage Ratings up to 800Vdc and Current Ratings up to 150Adc
- Standard 19" Width for ATE and System rackmount integration
- High Power Density - 1.2kW/1.5kW in a 1U package
- Fan-speed Control to reduce acoustic noise
- Remote Sensing to compensate for measurement errors due to large line drops
- High-resolution 16 bit ADC & DAC Design
- Active Down Programming Control for fast down programming speed
- Remote Programming Control with Standardized SCPI Commands for integrated ATE testing available
- Polarity Reversal & Isolation Output Relays available
- LabVIEW/LabWindows Drivers
- Modified & Customized Solutions

K- Panel Version (Keypad and Encoder)



- Standard Embedded RS-232, IEEE488.2 SCPI/GPIB, USB, and Ethernet Interfaces
- User-friendly Keypad and Real-time Encoder allows flexible control
- 16 bit Digital Design for high-resolution accurate measurements via a 2X20 VFD display or remote interfaces without the need for a DMM
- The V_{LIST} (voltage) and I_{LIST} (current) Stepping Modes generate user-defined sequence of output level up to 20 steps (points), with dwell times from 10ms to 1 minute stored in 4 profiles (This sequence can be cycled once or to a user-defined number of cycles)
- Designed with durability, reliability and DUT protection in mind – Programmable OVP (Over-voltage Protection), OCP (Over-current Protection), Redundant OTP (Over-temperature Protection), UVP (Under-voltage Protection), Remote Lockout (for I_{LIST} , V_{LIST} and ATE), Remote Inhibit (RI) & TTL Fault Output Signal for system level protection

V – Panel Version (Voltage/Current Encoder Knobs)



- Dual encoders and front panel indicators for real-time control and monitoring
- 16 bit ADC/DAC design for high-resolution measurements via dual-LED displays or Remote Read back without the need for a DMM
- Total Modular System Control
- Control multiple units as a single block and master/slave parallel the power supplies with built-in active current sharing via the RS-485, with enhanced front panel ventilation to achieve simple and economical system expansion in a zero-stack configuration
- Output Sequencing precisely controls individual power supply output on/off states with timed delays
- Embedded RS-232, RS-485, IEEE488.2 SCPI/GPIB, and optional USB/Ethernet for flexible ATE integration

- Programmable OVP (Over-voltage Protection) and OCP (Over-current Protection), redundant OTP (Over-temperature Protection) & UVP (Under-voltage Protection)
- Interlock protection ready - Remote Inhibit (RI) & TTL Fault Output Signal for system level protection
- The V_{LIST} (voltage) and I_{LIST} (current) stepping modes via remote programming
- Electronic Remote/Local Closed-cased calibration
- RS-485 controlled models are available without front panel control

1.5kW Version (Highest Power Density)

- Includes all features of the V-version SPS
- Up to 1.5kW power output in a single 1U box with 208 or 240Vac input
- RS-485 Controlled 1.5kW Modules with active current sharing provides flexible & simple system expansion to fulfill future test requirements by adding to existing systems instead of purchasing expensive new systems



0 – Panel Version (Voltage/Current Potentiometer)



- Simultaneous digital display of both current and voltage, and dual Ten-turn potentiometer for high resolution setting of the output voltage and current from zero to the rated output
- Front panel trim adjustment for OVP set points. Front panel (LED) indicators for constant voltage and constant current mode operation, OVP, thermal, and TTL shutdown (S/D)
- 0 ~ 5Vdc Remote voltage and current monitor, 0 ~ 5Vdc/0 ~ 10Vdc remote voltage/current programming
- Embedded RS-232, IEEE488.2 SCPI/GPIB, & RS-485

Remote Interfaces Available for simple and flexible ATE Integration

- Control multiple units as a single block and master/slave parallel the power supplies with built-in active current sharing via RS-485 to achieve simple and economical system expansion
- Analog-Only, control models available

Specifications ¹	SPS8-150	SPS20-60	SPS35-35	SPS40-30	SPS60-20	SPS80-15
Number of Outputs	1	1	1	1	1	1
Output Ratings						
Output Voltage 0-Vdc Max.	8.00	20.00	35.00	40.00	60.00	80.00
Output Current 0-Adc Max.	150.00	60.00	35.00	30.00	20.00	15.00
Maximum Output Power (W)	1200.00	1200.00	1225.00	1200.00	1200.00	1200.00
Programming Accuracy						
Voltage	0.05% of Setting +0.05% of FS	0.05% of Setting +0.05% of FS	0.05% of Setting +0.05% of FS	0.05% of Setting +0.05% of FS	0.05% of Setting +0.05% of FS	0.05% of Setting +0.05% of FS
Current	0.05% of Setting +0.05% of FS	0.05% of Setting +0.05% of FS	0.05% of Setting +0.05% of FS	0.05% of Setting +0.05% of FS	0.05% of Setting +0.05% of FS	0.05% of Setting +0.05% of FS
Over-Voltage Protection	0.2% of Vout +0.3% of FS	0.2% of Vout +0.3% of FS	0.2% of Vout +0.3% of FS	0.2% of Vout +0.3% of FS	0.2% of Vout +0.3% of FS	0.2% of Vout +0.3% of FS
Programming Resolution²						
Measurement Resolution²						
Voltage (mV)	0.80mV	2.00mV	3.50mV	4.00mV	6.00mV	8.00mV
Current (mA)	15.00mA	6.00mA	3.50mA	3.00mA	2.00mA	1.50mA
OVP (mV)	2.00mV	5.00mV	8.75mV	10.00mV	15.00mV	20.00mV
Measurement Accuracy						
Voltage	0.1% of Rdg +0.1% of FS	0.1% of Rdg +0.1% of FS	0.1% of Rdg +0.1% of FS	0.1% of Rdg +0.1% of FS	0.1% of Rdg +0.1% of FS	0.1% of Rdg +0.1% of FS
Current	0.1% of Rdg +0.2% of FS	0.1% of Rdg +0.2% of FS	0.1% of Rdg +0.2% of FS	0.1% of Rdg +0.2% of FS	0.1% of Rdg +0.2% of FS	0.1% of Rdg +0.2% of FS
Front Panel Display Accuracy						
Voltage (4 Digits)	0.1% of Rdg +0.1% of FS	0.1% of Rdg +0.1% of FS	0.1% of Rdg +0.1% of FS	0.1% of Rdg +0.1% of FS	0.1% of Rdg +0.1% of FS	0.1% of Rdg +0.1% of FS
Current (4 Digits)	0.1% of Rdg +0.2% of FS	0.1% of Rdg +0.2% of FS	0.1% of Rdg +0.2% of FS	0.1% of Rdg +0.2% of FS	0.1% of Rdg +0.2% of FS	0.1% of Rdg +0.2% of FS
Front Panel Resolution²						
Voltage	0.80mV	2.00mV	3.50mV	4.00mV	6.00mV	8.00mV
Current	15.00mA	6.00mA	3.50mA	3.00mA	2.00mA	1.50mA
Load Regulation³						
Voltage(0.01%*Vmax+ 2 mV)(mV)	2.80	4.00	5.50	6.00	8.00	10.00
Current(0.01%*Imax + 2 mA)(mA)	17.00	8.00	5.50	5.00	4.00	3.50
Line Regulation⁴						
Voltage(0.001%*Vmax+2mV)(mV)	2.08	2.20	2.35	2.40	2.60	2.80
Current(0.001%*Imax+ 2mA)(mA)	3.50	2.60	2.35	2.30	2.20	2.15
Ripple and Noise (20Hz~20MHz)⁵						
Voltage RMS (rms) (mV)	12	10	10	10	10	10
Voltage P-P(0 - 20 MHz, p-p)(mV)	75.0	70.0	50.0	50.0	50.0	75.0
Transient Response Time (ms)⁶	3.0	3.0	3.0	3.0	3.0	3.0
OVP Adjustment Range	0.4 ~ 8.8	1 ~ 22	1.75 ~ 38.5	2 ~ 44	3 ~ 66	4 ~ 88
Program. Speed(Tup/Tdn)(ms)⁷	100 / 100	100 / 100	100 / 100	100 / 100	100 / 100	100 / 100
Temperature Coefficient⁸						
CV (PPM/°C)	100	100	100	100	100	100
CC (PPM/°C)	100	100	100	100	100	100
AC Input⁹	103.5 ~ 126.5V or 207 ~ 253V	103.5 ~ 126.5V or 207 ~ 253V	103.5 ~ 126.5V or 207 ~ 253V	103.5 ~ 126.5V or 207 ~ 253V	103.5 ~ 126.5V or 207 ~ 253V	103.5 ~ 126.5V or 207 ~ 253V
Frequency	50 / 60 Hz	50 / 60 Hz	50 / 60 Hz	50 / 60 Hz	50 / 60 Hz	50 / 60 Hz
DC Output Isolation	+ 600 V	+ 600 V	+ 600 V	+ 600 V	+ 600 V	+ 600 V

*1: All electronic specifications are represented at the full operating temperature range for all models.

*2: The programming and readback resolution is based on 16 bit resolution design.

*3: Load regulation specifications are for 10 - 90% load changes.

*4: Line regulation specifications are for input voltage variation over the ac input voltage range with constant rated load.

Specifications ¹	SPS150-8	SPS300-4	SPS400-3	SPS450-2.5	SPS600-2	SPS800-1.5
Number of Outputs	1	1	1	1	1	1
Output Ratings						
Output Voltage 0-Vdc Max.	150.00	300.00	400.00	450.00	600.00	800.00
Output Current 0-Adc Max.	8.00	4.00	3.00	2.50	2.00	1.50
Maximum Output Power (W)	1200.00	1200.00	1200.00	1125.00	1200.00	1200.00
Programming Accuracy						
Voltage	0.05% of Setting +0.05% of FS	0.05% of Setting +0.05% of FS	0.05% of Setting +0.05% of FS	0.05% of Setting +0.05% of FS	0.05% of Setting +0.05% of FS	0.05% of Setting +0.05% of FS
Current	0.05% of Setting +0.05% of FS	0.05% of Setting +0.05% of FS	0.05% of Setting +0.05% of FS	0.05% of Setting +0.05% of FS	0.05% of Setting +0.05% of FS	0.05% of Setting +0.05% of FS
Over-Voltage Protection	0.2% of Vout +0.3% of FS	0.2% of Vout +0.3% of FS	0.2% of Vout +0.3% of FS	0.2% of Vout +0.3% of FS	0.2% of Vout +0.3% of FS	0.2% of Vout +0.3% of FS
Programming Resolution ²						
Measurement Resolution ²						
Voltage (mV)	15.00mV	30.00mV	40.00mV	45.00mV	60.00mV	80.00mV
Current (mA)	0.80mA	0.40mA	0.30mA	0.25mA	0.20mA	0.15mA
OVP (mV)	37.50mV	75.00mV	100.00mV	112.50mV	150.00mV	200.00mV
Measurement Accuracy						
Voltage	0.1% of Rdg +0.1% of FS	0.1% of Rdg +0.1% of FS	0.1% of Rdg +0.1% of FS	0.1% of Rdg +0.1% of FS	0.1% of Rdg +0.1% of FS	0.1% of Rdg +0.1% of FS
Current	0.1% of Rdg +0.2% of FS	0.1% of Rdg +0.2% of FS	0.1% of Rdg +0.2% of FS	0.1% of Rdg +0.2% of FS	0.1% of Rdg +0.2% of FS	0.1% of Rdg +0.2% of FS
Front Panel Display Accuracy						
Voltage (4 Digits)	0.1% of Rdg +0.1% of FS	0.1% of Rdg +0.1% of FS	0.1% of Rdg +0.1% of FS	0.1% of Rdg +0.1% of FS	0.1% of Rdg +0.1% of FS	0.1% of Rdg +0.1% of FS
Current (4 Digits)	0.1% of Rdg +0.2% of FS	0.1% of Rdg +0.2% of FS	0.1% of Rdg +0.2% of FS	0.1% of Rdg +0.2% of FS	0.1% of Rdg +0.2% of FS	0.1% of Rdg +0.2% of FS
Front Panel Resolution ²						
Voltage	15.00mV	30.00mV	40.00mV	45.00mV	60.00mV	80.00mV
Current	0.80mA	0.40mA	0.30mA	0.25mA	0.20mA	0.15mA
Load Regulation ³						
Voltage(0.01%*Vmax+ 2 mV)(mV)	17.00	32.00	42.00	47.00	62.00	82.00
Current(0.01%*Imax + 2 mA)(mA)	2.80	2.40	2.30	2.25	2.20	2.15
Line Regulation ⁴						
Voltage(0.001%*Vmax+2mV)(mV)	3.50	5.00	6.00	6.50	8.00	10.00
Current(0.001%*Imax+ 2mA)(mA)	2.08	2.04	2.03	2.03	2.02	2.02
Ripple and Noise (20Hz~20MHz) ⁵						
Voltage RMS (rms) (mV)	15	25	10	10	10	12
Voltage P-P(0 - 20 MHz, p-p)(mV)	150.0	300.0	50.0	50.0	75.0	75.0
Transient Response Time (ms) ⁶	3.0	3.0	3.0	3.0	3.0	3.0
OVP Adjustment Range	7.5 ~ 165	15 ~ 330	20 ~ 440	22.5 ~ 495	30 ~ 660	40 ~ 880
Program. Speed(Tup/Tdn)(ms) ⁷	100 / 100	100 / 100	100 / 100	100 / 100	100 / 100	100 / 100
Temperature Coefficient ⁸						
CV (PPM/°C)	100	100	100	100	100	100
CC (PPM/°C)	100	100	100	100	100	100
AC Input ⁹	103.5 ~ 126.5V or 207 ~ 253V	103.5 ~ 126.5V or 207 ~ 253V	103.5 ~ 126.5V or 207 ~ 253V	103.5 ~ 126.5V or 207 ~ 253V	103.5 ~ 126.5V or 207 ~ 253V	103.5 ~ 126.5V or 207 ~ 253V
Frequency	50 / 60 Hz	50 / 60 Hz	50 / 60 Hz	50 / 60 Hz	50 / 60 Hz	50 / 60 Hz
DC Output Isolation	+ 600 V	+ 600 V	+ 600 V	+ 600 V	+ 600 V	+ 800 V

*5: Ripple and Noise specifications are for 10 - 100% output voltage and full output current.

*6: Time for output voltage to recover to within +/- 0.5% of V_{FULL-SCALE} following a 10% ~ 60% load current change.

*7: Programming speed specifications are for 50% of full current loading.

*8: Temperature coefficient specifies output change per °C in ambient temperature rise following 30 minute warm up with constant line and load.

*9: AC Input is fixed and factory configured to either 103.5 ~ 126.5Vac or 207 ~ 253Vac @ 50/60Hz.

Specifications ¹	SPS8-150	SPS20-60	SPS35-35	SPS40-30	SPS60-20	SPS80-15
Number of Outputs	1	1	1	1	1	1
Output Ratings						
Output Voltage 0-Vdc Max.	8.00	20.00	35.00	40.00	60.00	80.00
Output Current 0-Adc Max.	150.00	60.00	35.00	30.00	20.00	15.00
Maximum Output Power (W)	1200.00	1200.00	1225.00	1200.00	1200.00	1200.00
Programming Accuracy						
Voltage	0.05% of Setting +0.05% of FS	0.05% of Setting +0.05% of FS	0.05% of Setting +0.05% of FS	0.05% of Setting +0.05% of FS	0.05% of Setting +0.05% of FS	0.05% of Setting +0.05% of FS
Current	0.05% of Setting +0.05% of FS	0.05% of Setting +0.05% of FS	0.05% of Setting +0.05% of FS	0.05% of Setting +0.05% of FS	0.05% of Setting +0.05% of FS	0.05% of Setting +0.05% of FS
Over-Voltage Protection	0.2% of Vout +0.3% of FS	0.2% of Vout +0.3% of FS	0.2% of Vout +0.3% of FS	0.2% of Vout +0.3% of FS	0.2% of Vout +0.3% of FS	0.2% of Vout +0.3% of FS
Programming Resolution ²						
Measurement Resolution ²						
Voltage (mV)	0.80mV	2.00mV	3.50mV	4.00mV	6.00mV	8.00mV
Current (mA)	15.00mA	6.00mA	3.50mA	3.00mA	2.00mA	1.50mA
OVP (mV)	2.00mV	5.00mV	8.75mV	10.00mV	15.00mV	20.00mV
Measurement Accuracy						
Voltage	0.1% of Rdg +0.1% of FS	0.1% of Rdg +0.1% of FS	0.1% of Rdg +0.1% of FS	0.1% of Rdg +0.1% of FS	0.1% of Rdg +0.1% of FS	0.1% of Rdg +0.1% of FS
Current	0.1% of Rdg +0.2% of FS	0.1% of Rdg +0.2% of FS	0.1% of Rdg +0.2% of FS	0.1% of Rdg +0.2% of FS	0.1% of Rdg +0.2% of FS	0.1% of Rdg +0.2% of FS
Front Panel Display Accuracy						
Voltage (4 Digits)	0.1% of Rdg + 10mV	0.1% of Rdg + 20mV	0.1% of Rdg + 40mV	0.1% of Rdg + 40mV	0.1% of Rdg + 60mV	0.1% of Rdg + 80mV
Current (4 Digits)	0.1% of Rdg+300mA	0.1% of Rdg+200mA	0.1% of Rdg+70mA	0.1% of Rdg+60mA	0.1% of Rdg+40mA	0.1% of Rdg+30mA
Front Panel Resolution ²						
Voltage	1mV	10mV	10mV	10mV	10mV	10mV
Current	100mA	10mA	10mA	10mA	10mA	10mA
Load Regulation ³						
Voltage(0.01%*Vmax+ 2 mV)(mV)	2.80	4.00	5.50	6.00	8.00	10.00
Current(0.01%*Imax + 2 mA)(mA)	17.00	8.00	5.50	5.00	4.00	3.50
Line Regulation ⁴						
Voltage(0.001%*Vmax+2mV)(mV)	2.08	2.20	2.35	2.40	2.60	2.80
Current(0.001%*Imax+ 2mA)(mA)	3.50	2.60	2.35	2.30	2.20	2.15
Ripple and Noise (20Hz-20MHz) ⁵						
Voltage RMS (rms) (mV)	12	10	10	10	10	10
Voltage P-P(0 - 20 MHz, p-p)(mV)	75.0	70.0	50.0	50.0	50.0	75.0
Transient Response Time (ms) ⁶	3.0	3.0	3.0	3.0	3.0	3.0
OVP Adjustment Range	0.4 ~ 8.8	1 ~ 22	1.75 ~ 38.5	2 ~ 44	3 ~ 66	4 ~ 88
Program. Speed(Tup/Tdn)(ms) ⁷	100 / 100	100 / 100	100 / 100	100 / 100	100 / 100	100 / 100
Temperature Coefficient ⁸						
CV (PPM/°C)	100	100	100	100	100	100
CC (PPM/°C)	100	100	100	100	100	100
AC Input ⁹	103.5 ~ 126.5V or 207 ~ 253V	103.5 ~ 126.5V or 207 ~ 253V	103.5 ~ 126.5V or 207 ~ 253V	103.5 ~ 126.5V or 207 ~ 253V	103.5 ~ 126.5V or 207 ~ 253V	103.5 ~ 126.5V or 207 ~ 253V
Frequency	50 / 60 Hz	50 / 60 Hz	50 / 60 Hz	50 / 60 Hz	50 / 60 Hz	50 / 60 Hz
DC Output Isolation	+ 600 V	+ 600 V	+ 600 V	+ 600 V	+ 600 V	+ 600 V

*1: All electronic specifications are represented at the full operating temperature range for all models.

*2: The programming and readback resolution is based on 16 bit resolution design.

*3: Load regulation specifications are for 10 - 90% load changes.

*4: Line regulation specifications are for input voltage variation over the ac input voltage range with constant rated load.

Specifications ¹	SPS150-8	SPS300-4	SPS400-3	SPS450-2.5	SPS600-2	SPS800-1.5
Number of Outputs	1	1	1	1	1	1
Output Ratings						
Output Voltage 0-Vdc Max.	150.00	300.00	400.00	450.00	600.00	800.00
Output Current 0-Adc Max.	8.00	4.00	3.00	2.50	2.00	1.50
Maximum Output Power (W)	1200.00	1200.00	1200.00	1125.00	1200.00	1200.00
Programming Accuracy						
Voltage	0.05% of Setting +0.05% of FS	0.05% of Setting +0.05% of FS	0.05% of Setting +0.05% of FS	0.05% of Setting +0.05% of FS	0.05% of Setting +0.05% of FS	0.05% of Setting +0.05% of FS
Current	0.05% of Setting +0.05% of FS	0.05% of Setting +0.05% of FS	0.05% of Setting +0.05% of FS	0.05% of Setting +0.05% of FS	0.05% of Setting +0.05% of FS	0.05% of Setting +0.05% of FS
Over-Voltage Protection	0.2% of Vout +0.3% of FS	0.2% of Vout +0.3% of FS	0.2% of Vout +0.3% of FS	0.2% of Vout +0.3% of FS	0.2% of Vout +0.3% of FS	0.2% of Vout +0.3% of FS
Programming Resolution ²						
Measurement Resolution ²						
Voltage (mV)	15.00mV	30.00mV	40.00mV	45.00mV	60.00mV	80.00mV
Current (mA)	0.80mA	0.40mA	0.30mA	0.25mA	0.20mA	0.15mA
OVP (mV)	37.50mV	75.00mV	100.00mV	112.50mV	150.00mV	200.00mV
Measurement Accuracy						
Voltage	0.1% of Rdg +0.1% of FS	0.1% of Rdg +0.1% of FS	0.1% of Rdg +0.1% of FS	0.1% of Rdg +0.1% of FS	0.1% of Rdg +0.1% of FS	0.1% of Rdg +0.1% of FS
Current	0.1% of Rdg +0.2% of FS	0.1% of Rdg +0.2% of FS	0.1% of Rdg +0.2% of FS	0.1% of Rdg +0.2% of FS	0.1% of Rdg +0.2% of FS	0.1% of Rdg +0.2% of FS
Front Panel Display Accuracy						
Voltage (4 Digits)	0.1% of Rdg + 200mV	0.1% of Rdg + 300mV	0.1% of Rdg + 400mV	0.1% of Rdg + 500mV	0.1% of Rdg + 600mV	0.1% of Rdg + 800mV
Current (4 Digits)	0.1% of Rdg+20mA	0.1% of Rdg+8mA	0.1% of Rdg+6mA	0.1% of Rdg+5mA	0.1% of Rdg+4mA	0.1% of Rdg+3mA
Front Panel Resolution ²						
Voltage	100mV	100mV	100mV	100mV	100mV	100mV
Current	1mA	1mA	1mA	1mA	1mA	1mA
Load Regulation ³						
Voltage(0.01%*Vmax+ 2 mV)(mV)	17.00	32.00	42.00	47.00	62.00	82.00
Current(0.01%*Imax + 2 mA)(mA)	2.80	2.40	2.30	2.25	2.20	2.15
Line Regulation ⁴						
Voltage(0.001%*Vmax+2mV)(mV)	3.50	5.00	6.00	6.50	8.00	10.00
Current(0.001%*Imax+ 2mA)(mA)	2.08	2.04	2.03	2.03	2.02	2.02
Ripple and Noise (20Hz~20MHz) ⁵						
Voltage RMS (rms) (mV)	15	25	10	10	10	12
Voltage P-P(0 - 20 MHz, p-p)(mV)	150.0	300.0	50.0	50.0	75.0	75.0
Transient Response Time (ms) ⁶	3.0	3.0	3.0	3.0	3.0	3.0
OVP Adjustment Range	7.5 ~ 165	15 ~ 330	20 ~ 440	22.5 ~ 495	30 ~ 660	40 ~ 880
Program. Speed(Tup/Tdn)(ms) ⁷	100 / 100	100 / 100	100 / 100	100 / 100	100 / 100	100 / 100
Temperature Coefficient ⁸						
CV (PPM/°C)	100	100	100	100	100	100
CC (PPM/°C)	100	100	100	100	100	100
AC Input ⁹	103.5 ~ 126.5V or 207 ~ 253V	103.5 ~ 126.5V or 207 ~ 253V	103.5 ~ 126.5V or 207 ~ 253V	103.5 ~ 126.5V or 207 ~ 253V	103.5 ~ 126.5V or 207 ~ 253V	103.5 ~ 126.5V or 207 ~ 253V
Frequency	50 / 60 Hz	50 / 60 Hz	50 / 60 Hz	50 / 60 Hz	50 / 60 Hz	50 / 60 Hz
DC Output Isolation	+ 600 V	+ 600 V	+ 600 V	+ 600 V	+ 600 V	+ 800 V

*5: Ripple and Noise specifications are for 10 - 100% output voltage and full output current.

*6: Time for output voltage to recover to within +/- 0.5% of $V_{FULL-SCALE}$ following a 10% ~ 60% load current change.

*7: Programming speed specifications are for 50% of full current loading.

*8: Temperature coefficient specifies output change per °C in ambient temperature rise following 30 minute warm up with constant line and load.

*9: AC Input is fixed and factory configured to either 120Vac: 103.5 ~ 126.5Vac or 208Vac: 187 ~ 229Vac or 230Vac: 207 ~ 253Vac @ 50/60Hz.

Specifications ¹	SPS8-150	SPS20-60	SPS35-35	SPS40-30	SPS60-20	SPS80-15	SPS150-8	SPS300-4	SPS400-3	SPS450-2.5	SPS600-2	SPS800-1.5
Number of Outputs	1	1	1	1	1	1	1	1	1	1	1	1
Output Ratings												
Output Voltage 0-Vdc Max. ²	8.0	20.0	35.0	40.0	60.0	80.0	150.0	300.0	400.0	450.0	600.0	800.0
Output Current 0-Adc Max. ³	150.0	60.0	35.0	30.0	20.0	15.0	8.0	4.0	3.0	2.5	2.0	1.5
Maximum Output Power (W)	1200.0	1200.0	1225.0	1200.0	1200.0	1200.0	1200.0	1200.0	1200.0	1125.0	1200.0	1200.0
Remote Programming Accuracy⁴												
Voltage(0.2% Vmax+10 mV)(mV)	26	50	80	90	130	170	310	610	810	910	1210	1610
Current(0.3% Imax + 10 mA)(mA)	460	190	115	100	70	55	34	22	19	17.5	16	14.5
OVP (5% + 100 mV) (V)	0.5	1.1	1.85	2.1	3.1	4.1	7.6	15.1	20.1	22.6	30.1	40.1
Remote Programming Resolution⁵												
Voltage (1.1 * Vmax / 65535) (mV)	0.13	0.34	0.59	0.67	1.01	1.34	2.52	5.04	6.71	7.55	10.07	13.43
Current (1.1 * Imax / 65535) (mA)	2.52	1.01	0.59	0.50	0.34	0.25	0.13	0.07	0.05	0.04	0.03	0.03
OVP (1.1 * Vmax / 65535) (mV)	0.13	0.34	0.59	0.67	1.01	1.34	2.52	5.04	6.71	7.55	10.07	13.43
Remote Readback Accuracy⁴												
Voltage(0.2%*Vmax+20 mV)(mV)	36	60	90	100	140	180	320	620	820	920	1220	1620
Current(0.3%*Imax + 20 mA)(mA)	470	200	125	110	80	65	44	32	29	27.5	26	24.5
Remote Readback Resolution⁵												
Voltage (1.1 * Vmax / 65535) (mV)	0.13	0.34	0.59	0.67	1.01	1.34	2.52	5.04	6.71	7.55	10.07	13.43
Current (1.1 * Imax / 65535) (mA)	2.52	1.01	0.59	0.50	0.34	0.25	0.13	0.07	0.05	0.04	0.03	0.03
Local Meter Accuracy												
Voltage(0.5%*Vmax+1 count)(mV)	48	120	210	240	360	480	900	1800	2400	2700	3600	4800
Current(0.5%*Imax+1 count)(mA)	900	360	210	180	120	90	48	24	18	15	12	9
Load Regulation⁶												
Voltage(0.02%*Vmax+5 mV)(mV)	6.6	9	12	13	17	21	35	65	85	95	125	165
Current(0.03%*Imax + 5 mA)(mA)	50	23	15.5	14	11	9.5	7.4	6.2	5.9	5.75	5.6	5.45
Line Regulation⁷												
Voltage(0.01%*Vmax+2 mV)(mV)	2.8	4	5.5	6	8	10	17	32	42	47	62	82
Current(0.01%*Imax + 2 mA)(mA)	17	8	5.5	5	4	3.5	2.8	2.4	2.3	2.25	2.2	2.15
Ripple and Noise (20Hz~20MHz)⁸												
Voltage RMS (rms) (mV)	12	10	10	10	10	10	15.0	25.0	30	40	40	40
Voltage P-P(0 - 20 MHz, p-p)(mV)	75.0	70.0	50.0	50	50	75	150.0	300.0	350	350	400	400
Transient Response Time (ms)⁹	3.0	3.0	3.0	3	3	3	3.0	5.1	3	3	3	3
OVP Adjustment Range 5% - 110% of Vmax (V)	0.4 - 8.8	1 - 22	1.8 - 38.5	2 - 44	3 - 66	4 - 88	7.5 - 165	15 - 330	20 - 440	22 - 495	30 - 660	40 - 880
Programming Speed(Tup/Tdn)(mS)¹⁰	100 / 100	100 / 100	100 / 100	100 / 100	100 / 100	100 / 100	100 / 100	100 / 100	100 / 100	100 / 100	100 / 100	100 / 100
Drift (8 Hours)¹¹												
CV Mode (0.5%*Vmax) (mV)	40	100	175	200	300	400	750	1500	2000	2250	3000	4000
CC Mode (0.5%*Imax) (mA)	750	300	175	150	100	75	40	20	15	12.5	10	7.5
Temp. Coefficient¹²												
CV Mode(0.02%*Vmax/C)(mV/C)	1.6	4	7	8	12	16	30	60	80	90	120	160
CC Mode(0.03%*Imax/C)(mA/C)	45	18	10.5	9	6	4.5	2.4	1.2	0.9	0.75	0.6	0.45
AC Input (Factory Configured AC Range)	103.5~126.5V or 207~253V	103.5~126.5V or 207~253V	103.5~126.5V or 207~253V	103.5~126.5V or 207~253V	103.5~126.5V or 207~253V	103.5~126.5V or 207~253V	103.5~126.5V or 207~253V	103.5~126.5V or 207~253V	103.5~126.5V or 207~253V	103.5~126.5V or 207~253V	103.5~126.5V or 207~253V	103.5~126.5V or 207~253V
Frequency	50 / 60 Hz	50 / 60 Hz	50 / 60 Hz	50 / 60 Hz	50 / 60 Hz	50 / 60 Hz	50 / 60 Hz	50 / 60 Hz	50 / 60 Hz	50 / 60 Hz	50 / 60 Hz	50 / 60 Hz
DC Output Isolation	± 600 V	± 600 V	± 600 V	± 600 V	± 600 V	± 600 V	± 600 V	± 600 V	± 600 V	± 600 V	± 600 V	± 800 V

*1: All electronic specifications are represented at the full operating temperature range for all models.

*2: Minimum voltage is guaranteed to maximum 0.15% of the rated output voltage.

*3: Minimum current is guaranteed to maximum 0.5% of the rated output current.

*4: The remote programming/readback accuracy specifications are guaranteed within 0.2% of max rated voltage and 0.3% of max rated current plus offset.

*5: The remote programming and readback resolutions are based on 16 bit resolution.

*6: Load regulation specifications are for 10 - 90% load changes.

*7: Line regulation specifications are for input voltage variation over the ac input voltage range with constant rated load.

*8: Ripple and Noise specifications are for 10 - 100% output voltage and full output current.

*9: Time for output voltage to recover to within +/- 0.5% of V_{FULL-SCALE} following a 10% ~ 60% load current change.

*10: Programming speed specifications are for 50% of full current loading.

*11: Drift specifications are maximum drift over 8 hours with constant line, load, and temperature after 30 minutes of warm-up.

*12: Temperature coefficient specifications are for changes in output per °C change in ambient temperature with constant line and load.

Specifications ¹	SPS12-125	SPS20-75	SPS60-25	SPS150-10	SPS600-2.5
Number of Outputs	1	1	1	1	1
Output Ratings					
Output Voltage 0-Vdc Max.	12.0	20.0	60.0	150.0	600.0
Output Voltage 0-Adc Max.	125.0	75.0	25.0	10.0	2.5
Maximum Output Power (W)	1500.0	1500.0	1500.0	1500.0	1500.0
Programming Accuracy					
Voltage	0.05% of Setting + 0.05% of FS	0.05% of Setting + 0.05% of FS	0.05% of Setting + 0.05% of FS	0.05% of Setting + 0.05% of FS	0.05% of Setting + 0.05% of FS
Current	0.05% of Setting + 0.05% of FS	0.05% of Setting + 0.05% of FS	0.05% of Setting + 0.05% of FS	0.05% of Setting + 0.05% of FS	0.05% of Setting + 0.05% of FS
Over-Voltage Protection	0.2% of Vout + 0.3% of FS	0.2% of Vout + 0.3% of FS	0.2% of Vout + 0.3% of FS	0.2% of Vout + 0.3% of FS	0.2% of Vout + 0.3% of FS
Programming Resolution²					
Measurement Resolution²					
Voltage (mV)	1.20mV	2.00mV	6.00mV	15.00mV	60.00mV
Current (mA)	12.50mA	7.50mA	2.50mA	1.00mA	0.25mA
OVP (mV)	3.00mV	5.00mV	15.00mV	37.50mV	150.00mV
Measurement Accuracy					
Voltage	0.1% of Rdg + 0.1% of FS	0.1% of Rdg + 0.1% of FS	0.1% of Rdg + 0.1% of FS	0.1% of Rdg + 0.1% of FS	0.1% of Rdg + 0.1% of FS
Current	0.1% of Rdg + 0.2% of FS	0.1% of Rdg + 0.2% of FS	0.1% of Rdg + 0.2% of FS	0.1% of Rdg + 0.2% of FS	0.1% of Rdg + 0.2% of FS
Front Panel Display Accuracy					
Voltage	4 Digits / 0.1% of Rdg + 20mV	4 Digits / 0.1% of Rdg + 20mV	4 Digits / 0.1% of Rdg + 60mV	4 Digits / 0.1% of Rdg + 200mV	4 Digits / 0.1% of Rdg + 600mV
Current	4 Digits / 0.1% of Rdg + 300mA	4 Digits / 0.1% of Rdg + 150mA	4 Digits / 0.1% of Rdg + 50mA	4 Digits / 0.1% of Rdg + 20mA	4 Digits / 0.1% of Rdg + 5mA
Front Panel Resolution					
Voltage	10mV	10mV	10mV	100mV	100mV
Current	100mA	10mA	10mA	10mA	10mA
Load Regulation³					
Voltage (0.01%*Vmax + 2 mV) (mV)	3.2	4	8	17	62
Current (0.01%*Imax + 2 mA) (mA)	14.5	9.5	4.5	3	2.25
Line Regulation⁴					
Voltage (0.001%*Vmax + 2 mV) (mV)	2.12	2.2	2.6	3.5	8
Current (0.001%*Imax + 2 mA) (mA)	3.25	2.75	2.25	2.1	2.025
Ripple and Noise (20Hz~20MHz)⁵					
Voltage RMS (rms) (mV)	8	8	8	10	30
Voltage P-P (0 - 20 MHz, p-p) (mV)	50.0	50.0	50.0	100.0	250.0
Transient Response Time (ms)⁶	3.0	3.0	3.0	3.0	3.0
OVP Adjustment Range	0.6 ~ 13.2	1 ~ 22	3 ~ 66	7.5 ~ 165	30 ~ 660
Programming Speed (Tup/Tdn) (ms)⁷	100 / 100	100 / 100	100 / 100	170 / 170	170 / 170
Temp. Coefficient⁸					
CV (PPM/°C)	100	100	100	100	100
CC (PPM/°C)	100	100	100	100	100
AC Input⁹	187 ~ 229Vac or 207 ~ 253Vac	187 ~ 229Vac or 207 ~ 253Vac	187 ~ 229Vac or 207 ~ 253Vac	187 ~ 229Vac or 207 ~ 253Vac	187 ~ 229Vac or 207 ~ 253Vac
Frequency	50 / 60 Hz	50 / 60 Hz	50 / 60 Hz	50 / 60 Hz	50 / 60 Hz
DC Output Isolation	+ 600 V	+ 600 V	+ 600 V	+ 600 V	+ 600 V

*1: All electronic specifications are represented at the full operating temperature range for all models and subject to change without notice.

*2: The programming and measurement resolution is based on 16 bit resolution design

*3: Load regulation specifications are for 10 - 90% load changes.

*4: Line regulation specifications are for input voltage variation over the ac input voltage range with constant rated load

*5: Ripple and Noise specifications are for 10 - 100% output voltage and full output current.

*6: Time for output voltage to recover to within +/- 0.5% of $V_{FULL-SCALE}$ following a 10% ~ 60% load current change.

*7: Programming speed specifications are for 50% of full current loading.

*8: Temperature coefficient specifies output change per °C in ambient temperature rise following 30 minute warm up with constant line and load.

*9: AC Input is fixed and factory configured to either 208Vac: 187.5 ~ 229Vac or 240Vac: 207 ~ 253Vac @ 50/60Hz.

Selector Guide for SPS 1.2kW Models (K-Panel Version)

SPS XXX-XXX-KOEX

- AC Input: **0** = 120Vac
1 = 240Vac
- Computer Interfaces: **E** = Ethernet, USB, GPIB, and RS232
- Output Isolation/Polarity Reversal Relays: **0** = None (Not available on these models)
- Front Panel Version: **K** = Keypad and Encoder Knob

Maximum Current
Maximum Voltage



FRONT VIEW



REAR VIEW

Selector Guide for SPS 1.2kW /1.5kW Models (V-Panel Version)

SPS XXX-XXX-V0XX

- AC Input: **0** = 120Vac (not available on 1.5kW models)
1 = 240Vac
8 = 208Vac
- Computer Interfaces: **2** = GPIB and RS-232
E = Ethernet, USB, GPIB and RS-232
- Output Isolation/Polarity Reversal Relays: **0** = None (Not available for these models)
- Front Panel Version: **V** = Vented Panel with Voltage/Current Encoder Knobs

Maximum Current Rating
Maximum Voltage Rating

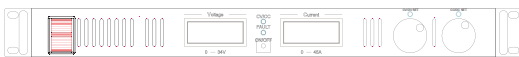

FRONT VIEW

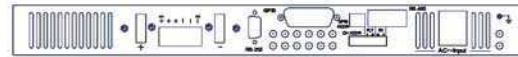

REAR VIEW

Selector Guide for SPS 1.2kW Models (0-Panel Version)

SPS XXX-XXX-0XXX

- AC Input: **0** = 120Vac
1 = 240Vac
- Computer Interfaces: **0** = None
2 = GPIB, RS-232, and RS-485
- Output Isolation/Polarity Reversal Relays: **0** = None
1 = Included
- Front Panel Version: **0** = Voltage/Current Control Potentiometer

Maximum Current Rating
Maximum Voltage Rating



FRONT VIEW



REAR VIEW

SPD DUAL CHANNEL

PROGRAMMABLE SWITCH MODE POWER SUPPLIES

Common Features for ALL SPD Models

- High-resolution 16 bit ADC/DAC Design provides accurate and precise voltage and current measurements simultaneously without the need for an external DMM
- Independent Dual-channel Voltage/Current Programming and Readback
- Simple & Flexible ATE Integration - embedded RS-232, IEEE488.2, SCPI/GPIB, RS-485, and Ethernet interfaces available
- Automatic Constant Current or Constant Voltage Mode Crossover
- Master/Slave Parallel Capability via RS-485 for simple multi-channel configuration and control
- Multiple units can be connected in parallel or in series to provide increased voltage or current
- Remote Inhibit (RI) and Fault Monitoring (FLT) Functions can be performed via a simple connector
- Economical and Expandable Dual Channel 360W Per Output in a Single 1U Chassis fills the power gap between available 200W and 600W outputs
- Remote Sensing to compensate for measurement errors due to large line drops
- Electronic Remote/Local Closed-cased Calibration
- Active Down Programming Control for fast down programming speed
- Low Ripple and Noise (PARD)
- LabVIEW/LabWindows Drivers

0 - Panel Version

- Independent 4 digit LED Voltage and Current Display for each channel and monitoring indicators
- A single SPD Master Unit can control up to a total of 64 channels via a single IEEE488.2 SCPI/GPIB RS-232, RS-485 or Ethernet computer connection, eliminating the increased costs of purchasing multiple systems with built-in controllers
- V_{LIST} (voltage) and I_{LIST} (current) Stepping Modes Accessible via Remote Programming



K - Panel Version (Keypad and Encoder)



- Standard Embedded RS-232, IEEE488.2 SCPI/GPIB, and Ethernet Interfaces for flexible connectivity
- Precise Voltage/Current Measurements, Programmable OVP, OCP, V_{LIST} , I_{LIST} , and other system indicators are conveniently presented on a 20X2 VFD display
- Designed with durability, reliability and DUT protection in mind – Programmable OVP (Over-voltage Protection), and OCP (Over-current Protection), Redundant OTP (Over-temperature Protection), UVP (Under-voltage Protection), Remote Lockout (for I_{LIST} , V_{LIST} and ATE), Fan-speed Control, External Power Supply Output Shut Down & TTL Fault Output Signal for system level protection
- Auto-tracking Feature
- The V_{LIST} (voltage) and I_{LIST} (current) Stepping Modes Generate User-defined Sequence of output levels up to a 20 steps (points), with dwell times from 10ms to 1 minute stored in 4 profiles (This sequence can be cycled once or to a user-defined number of cycles)
- Master/Slave Parallel Capability available

Specifications ¹	SPD8-40	SPD20-18	SPD30-10	SPD40-8
Number of Outputs	2	2	2	2
Each Output Ratings				
Output Voltage 0-Vdc Max.	8.0	20.0	30.0	40.0
Output Current 0-Adc Max.	40.0	18.0	10.0	8.0
Maximum Output Power (W)	320.0	360.0	300.0	320.0
Programming Accuracy				
Voltage	0.05% of Setting + 0.05% of FS	0.05% of Setting + 0.05% of FS	0.05% of Setting + 0.05% of FS	0.05% of Setting + 0.05% of FS
Current	0.05% of Setting + 0.05% of FS	0.05% of Setting + 0.05% of FS	0.05% of Setting + 0.05% of FS	0.05% of Setting + 0.05% of FS
Over-Voltage Protection	0.2% of Vout + 0.3% of FS	0.2% of Vout + 0.3% of FS	0.2% of Vout + 0.3% of FS	0.2% of Vout + 0.3% of FS
Programming Resolution²				
Measurement Resolution²				
Voltage (mV)	0.80mV	2.00mV	3.00mV	4.00mV
Current (mA)	4.00mA	1.80mA	1.00mA	0.80mA
OVP (mV)	2.00mV	5.00mV	7.50mV	10.00mV
Measurement Accuracy				
Voltage	0.1% of Rdg + 0.1% of FS	0.1% of Rdg + 0.1% of FS	0.1% of Rdg + 0.1% of FS	0.1% of Rdg + 0.1% of FS
Current	0.1% of Rdg + 0.2% of FS	0.1% of Rdg + 0.2% of FS	0.1% of Rdg + 0.2% of FS	0.1% of Rdg + 0.2% of FS
Front Panel Display Accuracy				
Voltage	4 Digits / 0.1% of Rdg + 0.1% of FS	4 Digits / 0.1% of Rdg + 0.1% of FS	4 Digits / 0.1% of Rdg + 0.1% of FS	4 Digits / 0.1% of Rdg + 0.1% of FS
Current	4 Digits / 0.1% of Rdg + 0.2% of FS	4 Digits / 0.1% of Rdg + 0.2% of FS	4 Digits / 0.1% of Rdg + 0.2% of FS	4 Digits / 0.1% of Rdg + 0.2% of FS
Front Panel Resolution				
Voltage	0.80mV	2.00mV	3.00mV	4.00mV
Current	4.00mA	1.80mA	1.00mA	0.80mA
Load Regulation³				
Voltage (0.01%*Vmax + 2 mV) (mV)	2.8	4	5	6
Current (0.01%*Imax + 2 mA) (mA)	6	3.8	3	2.8
Line Regulation⁴				
Voltage (0.001%*Vmax + 2 mV) (mV)	2.08	2.2	2.3	2.4
Current (0.001%*Imax + 2 mA) (mA)	2.4	2.18	2.1	2.08
Ripple and Noise (20Hz~20MHz)⁵				
Voltage RMS (rms) (mV)	1	1	1	1
Voltage P-P (0 - 20 MHz, p-p) (mV)	15.0	15.0	15.0	15.0
Transient Response Time (ms)⁶	3.0	3.0	3.0	3.0
OVP Adjustment Range	0.4 ~ 8.8	1 ~ 22	1.5 ~ 33	2 ~ 44
Programming Speed (Tup/Tdn) (ms)⁷	100 / 100	100 / 100	100 / 100	100 / 100
Temperature Coefficient⁸				
CV (PPM/°C)	100	100	100	100
CC (PPM/°C)	100	100	100	100
AC Input⁹	103.5 ~ 126.5V or 207 ~ 253V	103.5 ~ 126.5V or 207 ~ 253V	103.5 ~ 126.5V or 207 ~ 253V	103.5 ~ 126.5V or 207 ~ 253V
Frequency	50 / 60 Hz	50 / 60 Hz	50 / 60 Hz	50 / 60 Hz
DC Output Isolation	+ 600 V	+ 600 V	+ 600 V	+ 600 V

*1: All electronic specifications are represented at the full operating temperature range for all models.

*2: The programming and readback resolution is based on 16 bit resolution design.

*3: Load regulation specifications are for 10 - 90% load changes.

*4: Line regulation specifications are for input voltage variation over the ac input voltage range with constant rated load.

*5: Ripple and Noise specifications are for 10 - 100% output voltage and full output current.

*6: Time for output voltage to recover within +/- 0.5% of VFULL-SCALE following a 10% ~ 60% load current change.

Specifications ¹	SPD60-6	SPD80-4	SPD120-3	SPD300-1
Number of Outputs	2	2	2	2
Each Output Ratings				
Output Voltage 0-Vdc Max.	60.0	80.0	120.0	300.0
Output Current 0-Adc Max.	6.0	4.0	3.0	1.0
Maximum Output Power (W)	360.0	320.0	360.0	300.0
Programming Accuracy				
Voltage	0.05% of Setting + 0.05% of FS	0.05% of Setting + 0.05% of FS	0.05% of Setting + 0.05% of FS	0.05% of Setting + 0.05% of FS
Current	0.05% of Setting + 0.05% of FS	0.05% of Setting + 0.05% of FS	0.05% of Setting + 0.05% of FS	0.05% of Setting + 0.05% of FS
Over-Voltage Protection	0.2% of Vout + 0.3% of FS	0.2% of Vout + 0.3% of FS	0.2% of Vout + 0.3% of FS	0.2% of Vout + 0.3% of FS
Programming Resolution²				
Measurement Resolution²				
Voltage (mV)	6.00mV	8.00mV	12.00mV	30.00mV
Current (mA)	0.60mA	0.40mA	0.30mA	0.10mA
OVP (mV)	15.00mV	20.00mV	30.00mV	75.00mV
Measurement Accuracy				
Voltage	0.1% of Rdg + 0.1% of FS	0.1% of Rdg + 0.1% of FS	0.1% of Rdg + 0.1% of FS	0.1% of Rdg + 0.1% of FS
Current	0.1% of Rdg + 0.2% of FS	0.1% of Rdg + 0.2% of FS	0.1% of Rdg + 0.2% of FS	0.1% of Rdg + 0.2% of FS
Front Panel Display Accuracy				
Voltage	4 Digits / 0.1% of Rdg + 0.1% of FS	4 Digits / 0.1% of Rdg + 0.1% of FS	4 Digits / 0.1% of Rdg + 0.1% of FS	4 Digits / 0.1% of Rdg + 0.1% of FS
Current	4 Digits / 0.1% of Rdg + 0.2% of FS	4 Digits / 0.1% of Rdg + 0.2% of FS	4 Digits / 0.1% of Rdg + 0.2% of FS	4 Digits / 0.1% of Rdg + 0.2% of FS
Front Panel Resolution				
Voltage	6.00mV	8.00mV	12.00mV	30.00mV
Current	0.60mA	0.40mA	0.30mA	0.10mA
Load Regulation³				
Voltage (0.01%*Vmax + 2 mV) (mV)	8	10	14	32
Current (0.01%*Imax + 2 mA) (mA)	2.6	2.4	2.3	2.1
Line Regulation⁴				
Voltage (0.001%*Vmax + 2 mV) (mV)	2.6	2.8	3.2	5
Current (0.001%*Imax + 2 mA) (mA)	2.06	2.04	2.03	2.01
Ripple and Noise (20Hz~20MHz)⁵				
Voltage RMS (rms) (mV)	2	2	2	5
Voltage P-P (0 - 20 MHz, p-p) (mV)	30.0	30.0	30.0	50.0
Transient Response Time (ms)⁶	3.0	3.0	3.0	3.0
OVP Adjustment Range	3 ~ 66	4 ~ 88	6 ~ 132	15 ~ 330
Programming Speed (Tup/Tdn) (ms)⁷	100 / 100	100 / 180	100 / 180	100 / 180
Temperature Coefficient⁸				
CV (PPM/°C)	100	100	100	100
CC (PPM/°C)	100	100	100	100
AC Input⁹	103.5 ~ 126.5V or 207 ~ 253V	103.5 ~ 126.5V or 207 ~ 253V	103.5 ~ 126.5V or 207 ~ 253V	103.5 ~ 126.5V or 207 ~ 253V
Frequency	50 / 60 Hz	50 / 60 Hz	50 / 60 Hz	50 / 60 Hz
DC Output Isolation	+ 600 V	+ 600 V	+ 600 V	+ 600 V

*7: Programming speed specifications are for 50% of full current loading.

*8: Temperature coefficient specifies output change per °C in ambient temperature rise following 30 minute warm up, w/ constant line and load.

*9: AC Input is fixed and factory configured to either 120Vac: 103.5 ~ 126.5Vac or 208Vac: 187 ~ 229Vac or 230Vac: 207 ~ 253Vac @ 50/60Hz.

Specifications ¹	SPD8-40	SPD20-18	SPD30-10	SPD40-8
Number of Outputs	2	2	2	2
Each Output Ratings				
Output Voltage 0-Vdc Max.	8.0	20.0	30.0	40.0
Output Current 0-Adc Max.	40.0	18.0	10.0	8.0
Maximum Output Power (W)	320.0	360.0	300.0	320.0
Programming Accuracy				
Voltage	0.05% of Setting + 0.05% of FS	0.05% of Setting + 0.05% of FS	0.05% of Setting + 0.05% of FS	0.05% of Setting + 0.05% of FS
Current	0.05% of Setting + 0.05% of FS	0.05% of Setting + 0.05% of FS	0.05% of Setting + 0.05% of FS	0.05% of Setting + 0.05% of FS
Over-Voltage Protection	0.2% of Vout + 0.3% of FS	0.2% of Vout + 0.3% of FS	0.2% of Vout + 0.3% of FS	0.2% of Vout + 0.3% of FS
Programming Resolution²				
Measurement Resolution²				
Voltage (mV)	0.8mV	2.00mV	3.00mV	4.00mV
Current (mA)	4.00mA	1.80mA	1.00mA	0.80mA
OVP (mV)	2.00mV	5.00mV	7.50mV	10.00mV
Measurement Accuracy				
Voltage	0.1% of Rdg + 0.1% of FS	0.1% of Rdg + 0.1% of FS	0.1% of Rdg + 0.1% of FS	0.1% of Rdg + 0.1% of FS
Current	0.1% of Rdg + 0.2% of FS	0.1% of Rdg + 0.2% of FS	0.1% of Rdg + 0.2% of FS	0.1% of Rdg + 0.2% of FS
Front Panel Display Accuracy				
Voltage	4 Digits / 0.1% of Rdg + 10mV	4 Digits / 0.1% of Rdg + 20mV	4 Digits / 0.1% of Rdg + 30mV	4 Digits / 0.1% of Rdg + 40mV
Current	4 Digits / 0.1% of Rdg + 80mA	4 Digits / 0.1% of Rdg + 40mA	4 Digits / 0.1% of Rdg + 20mA	4 Digits / 0.1% of Rdg + 20mA
Front Panel Resolution				
Voltage	1mV	10mV	10mV	10mV
Current	10mA	10mA	10mA	1mA
Load Regulation³				
Voltage (0.01%*Vmax + 2 mV) (mV)	2.8	4	5	6
Current (0.01%*Imax + 2 mA) (mA)	6	3.8	3	2.8
Line Regulation⁴				
Voltage (0.001%*Vmax + 2 mV) (mV)	2.08	2.2	2.3	2.4
Current (0.001%*Imax + 2 mA) (mA)	2.4	2.18	2.1	2.08
Ripple and Noise (20Hz-20MHz)⁵				
Voltage RMS (ms) (mV)	1	1	1	1
Voltage P-P (0 - 20 MHz, p-p) (mV)	15.0	15.0	15.0	15.0
Transient Response Time (ms)⁶	3.0	3.0	3.0	3.0
OVP Adjustment Range	0.4 ~ 8.8	1 ~ 22	1.5 ~ 33	2 ~ 44
Programming Speed (Tup/Tdn) (ms)⁷	100 / 100	100 / 100	100 / 100	100 / 100
Temperature Coefficient⁸				
CV (PPM/°C)	100	100	100	100
CC (PPM/°C)	100	100	100	100
AC Input⁹	103.5 ~ 126.5V or 207 ~ 253V	103.5 ~ 126.5V or 207 ~ 253V	103.5 ~ 126.5V or 207 ~ 253V	103.5 ~ 126.5V or 207 ~ 253V
Frequency	50 / 60 Hz	50 / 60 Hz	50 / 60 Hz	50 / 60 Hz
DC Output Isolation	+600 V	+600 V	+600 V	+600 V

*1: All electronic specifications are represented at the full operating temperature range for all models.

*2: The programming and readback resolution is based on 16 bit resolution design.

*3: Load regulation specifications are for 10 - 90% load changes.

*4: Line regulation specifications are for input voltage variation over the ac input voltage range with constant rated load.

*5: Ripple and Noise specifications are for 10 - 100% output voltage and full output current.

*6: Time for output voltage to recover within +/- 0.5% of V_{FULL-SCALE} following a 10% ~ 60% load current change.

Specifications ¹	SPD60-6	SPD80-4	SPD120-3	SPD300-1
Number of Outputs	2	2	2	2
Each Output Ratings				
Output Voltage 0-Vdc Max.	60.0	80.0	120.0	300.0
Output Current 0-Adc Max.	6.0	4.0	3.0	1.0
Maximum Output Power (W)	360.0	320.0	360.0	300.0
Programming Accuracy				
Voltage	0.05% of Setting + 0.05% of FS	0.05% of Setting + 0.05% of FS	0.05% of Setting + 0.05% of FS	0.05% of Setting + 0.05% of FS
Current	0.05% of Setting + 0.05% of FS	0.05% of Setting + 0.05% of FS	0.05% of Setting + 0.05% of FS	0.05% of Setting + 0.05% of FS
Over-Voltage Protection	0.2% of Vout + 0.3% of FS	0.2% of Vout + 0.3% of FS	0.2% of Vout + 0.3% of FS	0.2% of Vout + 0.3% of FS
Programming Resolution²				
Measurement Resolution²				
Voltage (mV)	6.00mV	8.00mV	12.00mV	30.00mV
Current (mA)	0.60mA	0.40mA	0.30mA	0.10mA
OVP (mV)	15.00mV	20.00mV	30.00mV	75.00mV
Measurement Accuracy				
Voltage	0.1% of Rdg + 0.1% of FS	0.1% of Rdg + 0.1% of FS	0.1% of Rdg + 0.1% of FS	0.1% of Rdg + 0.1% of FS
Current	0.1% of Rdg + 0.2% of FS	0.1% of Rdg + 0.2% of FS	0.1% of Rdg + 0.2% of FS	0.1% of Rdg + 0.2% of FS
Front Panel Display Accuracy				
Voltage	4 Digits / 0.1% of Rdg + 60mV	4 Digits / 0.1% of Rdg + 80mV	4 Digits / 0.1% of Rdg + 120mV	4 Digits / 0.1% of Rdg + 300mV
Current	4 Digits / 0.1% of Rdg + 10mA	4 Digits / 0.1% of Rdg + 1mA	4 Digits / 0.1% of Rdg + 1mA	4 Digits / 0.1% of Rdg + 1mA
Front Panel Resolution				
Voltage	10mV	10mV	100mV	100mV
Current	1mA	1mA	1mA	1mA
Load Regulation³				
Voltage (0.01%*Vmax + 2 mV) (mV)	8	10	14	32
Current (0.01%*Imax + 2 mA) (mA)	2.6	2.4	2.3	2.1
Line Regulation⁴				
Voltage (0.001%*Vmax + 2 mV) (mV)	2.6	2.8	3.2	5
Current (0.001%*Imax + 2 mA) (mA)	2.06	2.04	2.03	2.01
Ripple and Noise (20Hz~20MHz)⁵				
Voltage RMS (rms) (mV)	2	2	2	5
Voltage P-P (0 - 20 MHz, p-p) (mV)	30.0	30.0	30.0	50.0
Transient Response Time (ms)⁶	3.0	3.0	3.0	3.0
OVP Adjustment Range	3 ~ 66	4 ~ 88	6 ~ 132	15 ~ 330
Programming Speed (Tup/Tdn) (ms)⁷	100 / 100	100 / 180	100 / 180	100 / 180
Temperature Coefficient⁸				
CV (PPM°C)	100	100	100	100
CC (PPM°C)	100	100	100	100
AC Input⁹	103.5 ~ 126.5V or 207 ~ 253V	103.5 ~ 126.5V or 207 ~ 253V	103.5 ~ 126.5V or 207 ~ 253V	103.5 ~ 126.5V or 207 ~ 253V
Frequency	50 / 60 Hz	50 / 60 Hz	50 / 60 Hz	50 / 60 Hz
DC Output Isolation	+ 600 V	+ 600 V	+ 600 V	+ 600 V

*7: Programming speed specifications are for 50% of full current loading.

*8: Temperature coefficient specifies output change per °C in ambient temperature rise following 30 minute warm up, w/ constant line and load.

*9: AC Input is fixed and factory configured to either 120Vac: 103.5 ~ 126.5Vac or 208Vac: 187 ~ 229Vac or 230Vac: 207 ~ 253Vac @ 50/60Hz.

SPD XXX-XXX-X0XX

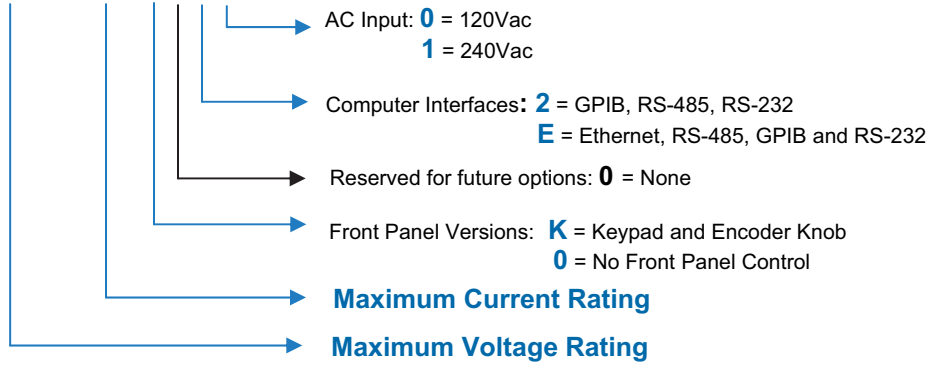

FRONT VIEW OF K-PANEL VERSION



FRONT VIEW OF 0-PANEL VERSION

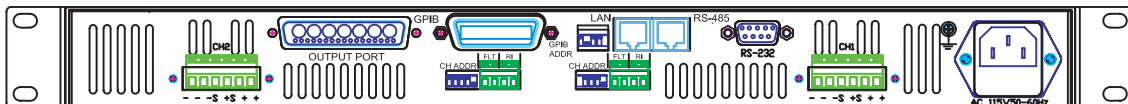

REAR VIEW

HPS and SPS (3.3kW-45kW)

PROGRAMMABLE SWITCH MODE POWER SUPPLIES

Features for SPS 3.3kW-45kW and ALL HPS High Power Switching Power Supplies



SPS 3.3kW and above Rackmount Models

- 20X2 VFD Displays Easy-to-read and Accurate Constant Voltage and Constant Current Settings and Values
- Digital OVP, OCP, I_{LIST} and V_{LIST} Display for easy function recognition
- Real-time Encoder provides precise and on-the-fly voltage and current control
- Automatic Constant Voltage & Constant Current Mode Crossover
- Multi-functional Front Panel Keypad for high resolution and precise digital OVP, OCP, I_{LIST} , V_{LIST} , current, and voltage control
- Remote Programming Control with standardized SCPI commands for advanced and integrated ATE testing
- MCU-2 Master Controller can control up to 8 SPS and cascaded for up to 800 SPS units – for extensive and versatile control of highly complex and integrated systems
- Embedded Ethernet and USB Interface Option without the need for interface converters
- Remote Inhibit (RI) and Interlock provides external output shutdown capability – in case of hazardous faults
- External Fault (FLT) and Remote Inhibit (RI) Signal for scaled remote ATE system integration
- Remote/Front Panel Lockout to ensure protection for remote ATE systems
- In-field GPIB, RS232, USB, Ethernet, and Firmware Upgrades to prevent down-time, satisfy new and dynamic system applications and provide up-to-date software maintenance
- 16 bit Readback and Programming A-D/D-A yields high resolution and accuracy for standalone or burn-in testing without the need for external measuring equipment
- Convenient and Robust Automated Testing - Four 20 Step profiles; Electronic Local/Remote Closed-case Calibration will minimize down-time, reduce maintenance costs, and elevate Return on Investment (ROI)
- Remote Sensing to compensate for measurement errors due to large line drops
- Increased control precision and convenience for external programming applications achieved through User-Selectable CV/CC/OV External Control, as well as Automated V_{LIST} and I_{LIST} Profiles
- LabVIEW/LabWindows Drivers

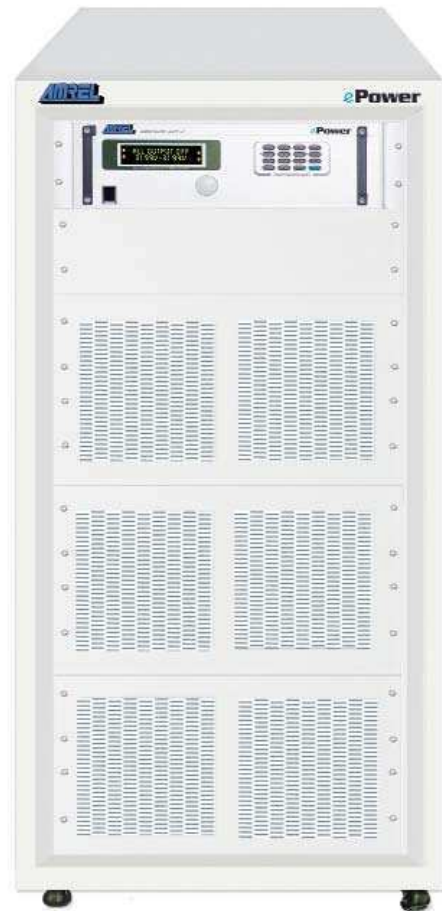

HPS Series High Power, Cabinet Mount Models

Common Specifications

Input voltage (Factory Configured):

208/240 Vac, 50-400 Hz, 3φ
 380/415 Vac, 50-400 Hz, 3φ
 440/480 Vac, 50-400 Hz, 3φ

Line regulation:

Voltage Mode: ±.004% of full scale
 Current Mode: ±.02% of full scale

Load regulation:

Voltage Mode: ±.01% of full scale
 Current Mode: ±.04% of full scale

Stability: 0.10 % for 8 hours after 30 minute warm up

Load transient response:

2 ms to recover within ±1% of regulated output with a 50% to 100% or 100% to 50% step load change

Efficiency: Greater than 86%

Temperature coefficient: 0.04 %/°C of maximum output current

Isolation:

Maximum input voltage to ground: ±2500 Vdc
 Maximum output voltage to ground: ±1000 Vdc
 User inputs and outputs: referenced to earth ground

Power Factor: Greater than 92% at maximum power

Ambient Temperature: 0 to 50°C

Storage Temperature: -25 to +85°C

Remote sense limits: 3% maximum voltage drop from output terminals to load

Digital programming accuracy of full scale:

Voltage set point: ±.50%
 Current set point: ±.75%
 Over voltage trip set point: ±.50%
 Over current trip set point: ±.75%

Digital readback accuracy of full scale:

Output voltage: ±.50%
 Output current: ±.75%

Dimensions SPS Models:

5¼"H x 19"W x 24"D (3.3kW to 15kW)
 10¼"H x 19"W x 24"D (20kW to 30kW)
 15 ¾"H x 19W x 24"D (45kW)

Dimensions HPS Models:

38 ½"H x 22"W x 29"D (30kW to 60kW)
 49"H x 22"W x 29"D (75kW)
 62 ½"H x 48"W x 31½"D (100kW, 150kW)

Models and Ratings

3.3kW SPS Models	Output Voltage (Vdc)	Output Current (A dc)	Ripple (mVrms)	3.3kW SPS Models	Output Voltage (Vdc)	Output Current (A dc)	Ripple (mVrms)
SPS5-600	5	600	50	SPS125-26	125	26	100
SPS8-400	8	400	40	SPS160-20	160	20	120
SPS10-300	10	300	40	SPS200-16	200	16	125
SPS16-200	16	200	35	SPS250-13	250	13	130
SPS20-165	20	165	40	SPS375-8	375	8	170
SPS32-100	32	100	40	SPS500-6	500	6	220
SPS40-82	40	82	40	SPS600-5	600	5	250
SPS60-55	60	55	40	SPS800-4	800	4	270
SPS80-41	80	41	60	SPS1000-3	1000	3	300
SPS100-33	100	33	60				

6.6kW SPS Models	Output Voltage (Vdc)	Output Current (A dc)	Ripple (mVrms)	6.6kW SPS Models	Output Voltage (Vdc)	Output Current (A dc)	Ripple (mVrms)
SPS8-800	8	800	40	SPS125-53	125	53	100
SPS10-600	10	600	40	SPS160-41	160	41	120
SPS16-400	16	400	35	SPS200-33	200	33	125
SPS20-330	20	330	40	SPS250-26	250	26	130
SPS32-200	32	200	40	SPS375-17	375	17	170
SPS40-165	40	165	40	SPS500-13	500	13	220
SPS50-130	50	130	50	SPS600-10	600	10	250
SPS60-110	60	110	50	SPS800-8	800	8	270
SPS80-82	80	82	60	SPS1000-6	1000	6	300
SPS100-66	100	66	60				

10kW SPS Models	Output Voltage (Vdc)	Output Current (A _{dc})	Ripple (mV _{rms})	10kW SPS Models	Output Voltage (Vdc)	Output Current (A _{dc})	Ripple (mV _{rms})
SPS10-900	10	900	40	SPS100-100	100	100	60
SPS16-600	16	600	35	SPS160-62	160	62	120
SPS20-500	20	500	40	SPS200-50	200	50	125
SPS32-300	32	300	40	SPS250-40	250	40	130
SPS40-250	40	250	40	SPS375-27	375	27	170
SPS50-200	50	200	50	SPS500-20	500	20	220
SPS60-167	60	167	50	SPS600-16	600	16	250
SPS80-125	80	125	60	SPS800-12	800	12	270
SPS125-80	125	80	100	SPS1000-10	1000	10	300

15kW SPS Models	Output Voltage (Vdc)	Output Current (A _{dc})	Ripple (mV _{rms})	15kW SPS Models	Output Voltage (Vdc)	Output Current (A _{dc})	Ripple (mV _{rms})
SPS16-900	16	900	35	SPS160-93	160	93	120
SPS20-750	20	750	40	SPS200-75	200	75	125
SPS32-450	32	450	40	SPS250-60	250	60	130
SPS40-375	40	375	40	SPS375-39	375	39	170
SPS50-300	50	300	50	SPS500-30	500	30	220
SPS60-250	60	250	50	SPS600-24	600	24	250
SPS80-186	80	186	60	SPS800-18	800	18	300
SPS100-150	100	150	60	SPS1000-15	1000	15	350
SPS100-151	100	150	60	SPS1000-16	1000	15	350
SPS125-120	125	120	100				

20kW SPS Models	Output Voltage (Vdc)	Output Current (A _{dc})	Ripple (mV _{rms})	20kW SPS Models	Output Voltage (Vdc)	Output Current (A _{dc})	Ripple (mV _{rms})
SPS16-1200	16	1200	35	SPS160-124	160	124	120
SPS20-1000	20	1000	40	SPS200-100	200	100	125
SPS32-600	32	600	40	SPS250-80	250	80	130
SPS40-500	40	500	40	SPS375-52	375	52	170
SPS50-400	50	400	50	SPS500-40	500	40	220
SPS60-333	60	333	50	SPS600-32	600	32	250
SPS80-248	80	248	60	SPS800-24	800	24	270
SPS100-200	100	200	60	SPS1000-20	1000	20	350
SPS125-160	125	160	100				

25kW SPS Models	Output Voltage (Vdc)	Output Current (A _{dc})	Ripple (mV _{rms})	25kW SPS Models	Output Voltage (Vdc)	Output Current (A _{dc})	Ripple (mV _{rms})
SPS16-1500	16	1500	35	SPS160-155	160	155	120
SPS20-1250	20	1250	40	SPS200-125	200	125	125
SPS32-750	32	750	40	SPS250-100	250	100	130
SPS40-625	40	625	40	SPS375-65	375	65	170
SPS50-500	50	500	50	SPS500-50	500	50	220
SPS60-416	60	416	50	SPS600-40	600	40	250
SPS80-310	80	310	60	SPS800-30	800	30	300
SPS100-250	100	250	60	SPS1000-25	1000	25	350
SPS125-200	125	200	100				

30kW SPS Models	Output Voltage (Vdc)	Output Current (Adc)	Ripple (mVrms)	30kW SPS Models	Output Voltage (Vdc)	Output Current (Adc)	Ripple (mVrms)
SPS16-1800	16	1800	35	SPS160-186	160	186	120
SPS20-1500	20	1500	40	SPS200-150	200	150	125
SPS32-900	32	900	40	SPS250-120	250	120	130
SPS40-750	40	750	40	SPS375-78	375	78	170
SPS50-600	50	600	50	SPS500-60	500	60	220
SPS60-500	60	500	50	SPS600-48	600	48	250
SPS80-372	80	372	60	SPS800-36	800	36	300
SPS100-300	100	300	60	SPS1000-30	1000	30	350
SPS125-240	125	240	100				

45kW SPS Models	Output Voltage (Vdc)	Output Current (Adc)	Ripple (mVrms)	45kW SPS Models	Output Voltage (Vdc)	Output Current (Adc)	Ripple (mVrms)
SPS16-2700	16	2700	35	SPS160-279	160	279	120
SPS20-2250	20	2250	40	SPS200-225	200	225	125
SPS32-1350	32	1350	40	SPS250-180	250	180	130
SPS40-1125	40	1125	40	SPS375-117	375	117	170
SPS50-900	50	900	50	SPS500-90	500	90	220
SPS60-750	60	750	50	SPS600-72	600	72	250
SPS80-558	80	558	60	SPS800-54	800	54	300
SPS100-450	100	450	60	SPS1000-45	1000	45	350
SPS125-360	125	360	100				

30kW HPS Models	Output Voltage (Vdc)	Output Current (Adc)	Ripple (mVrms)	30kW HPS Models	Output Voltage (Vdc)	Output Current (Adc)	Ripple (mVrms)
HPS16-1800	16	1800	35	HPS160-186	160	186	120
HPS20-1500	20	1500	40	HPS200-150	200	150	125
HPS32-900	32	900	40	HPS250-120	250	120	130
HPS40-750	40	750	40	HPS375-78	375	78	170
HPS50-600	50	600	50	HPS500-60	500	60	220
HPS60-500	60	500	50	HPS600-48	600	48	250
HPS80-372	80	372	60	HPS800-36	800	36	300
HPS100-300	100	300	60	HPS1000-30	1000	30	350
HPS125-240	125	240	100				

45kW HPS Models	Output Voltage (Vdc)	Output Current (Adc)	Ripple (mVrms)	45kW HPS Models	Output Voltage (Vdc)	Output Current (Adc)	Ripple (mVrms)
HPS16-2700	16	2700	35	HPS160-279	160	279	120
HPS20-2250	20	2250	40	HPS200-225	200	225	125
HPS32-1350	32	1350	40	HPS250-180	250	180	130
HPS40-1125	40	1125	40	HPS375-117	375	117	170
HPS50-900	50	900	50	HPS500-90	500	90	220
HPS60-750	60	750	50	HPS600-72	600	72	250
HPS80-558	80	558	60	HPS800-54	800	54	300
HPS100-450	100	450	60	HPS1000-45	1000	45	350
HPS125-360	125	360	100				

60kW HPS Models	Output Voltage (Vdc)	Output Current (Adc)	Ripple (mVrms)	60kW HPS Models	Output Voltage (Vdc)	Output Current (Adc)	Ripple (mVrms)
HPS16-3600	16	3600	35	HPS160-372	160	372	120
HPS20-3000	20	3000	40	HPS200-300	200	300	125
HPS32-1800	32	1800	40	HPS250-240	250	240	130
HPS40-1500	40	1500	40	HPS375-156	375	156	170
HPS50-1200	50	1200	50	HPS500-120	500	120	220
HPS80-744	80	744	60	HPS600-96	600	96	250
HPS100-600	100	600	60	HPS800-72	800	72	300
HPS125-125	125	125	100	HPS1000-60	1000	60	350

75kW HPS Models	Output Voltage (Vdc)	Output Current (Adc)	Ripple (mVrms)	75kW HPS Models	Output Voltage (Vdc)	Output Current (Adc)	Ripple (mVrms)
HPS16-4500	16	4500	35	HPS160-465	160	465	120
HPS20-3750	20	3750	40	HPS200-375	200	375	125
HPS32-2250	32	2250	40	HPS250-300	250	300	130
HPS40-1875	40	1875	40	HPS375-195	375	195	170
HPS50-1500	50	1500	50	HPS500-150	500	150	220
HPS80-930	80	930	60	HPS600-120	600	120	250
HPS100-750	100	750	60	HPS800-90	800	90	300
HPS125-600	125	600	100	HPS1000-75	1000	75	350

100kW HPS Models	Output Voltage (Vdc)	Output Current (Adc)	Ripple (mVrms)	100kW HPS Models	Output Voltage (Vdc)	Output Current (Adc)	Ripple (mVrms)
HPS16-6000	0-16	0-6000	35	HPS250-400	0-250	0-400	130
HPS20-5000	0-20	0-5000	40	HPS375-270	0-375	0-270	170
HPS32-3000	0-32	0-3000	40	HPS500-200	0-500	0-200	220
HPS40-2500	0-40	0-2500	40	HPS600-160	0-600	0-160	250
HPS50-2000	0-50	0-2000	50	HPS800-120	0-800	0-120	300
HPS80-1250	0-80	0-1250	60	HPS1000-100	0-1000	0-100	400
HPS100-1000	0-100	0-1000	60	HPS1250-80	0-1250	0-80	500
HPS125-800	0-125	0-800	100	HPS1600-62	0-1600	0-62	600
HPS160-620	0-160	0-620	120	HPS2000-50	0-2000	0-50	800
HPS200-500	0-200	0-500	125	HPS2500-40	0-2500	0-40	900

150kW HPS Models	Output Voltage (Vdc)	Output Current (Adc)	Ripple (mVrms)	150kW HPS Models	Output Voltage (Vdc)	Output Current (Adc)	Ripple (mVrms)
HPS25-6000	0-25	0-6000	40	HPS375-400	0-375	0-400	170
HPS32-4500	0-32	0-4500	40	HPS500-300	0-500	0-300	220
HPS40-3750	0-40	0-3750	40	HPS600-240	0-600	0-240	250
HPS50-3000	0-50	0-3000	50	HPS800-180	0-800	0-180	300
HPS80-1850	0-80	0-1850	60	HPS1000-150	0-1000	0-150	400
HPS100-1500	0-100	0-1500	60	HPS1250-120	0-1250	0-120	500
HPS125-1200	0-125	0-1200	100	HPS1600-90	0-1600	0-90	600
HPS160-900	0-160	0-900	120	HPS2000-75	0-2000	0-75	800
HPS200-750	0-200	0-750	125	HPS2500-60	0-2500	0-60	900
HPS250-600	0-250	0-600	130				

Please Note: Water-cooled models are available - contact AMREL for more information.

SPS XXX-XXX-K0XX

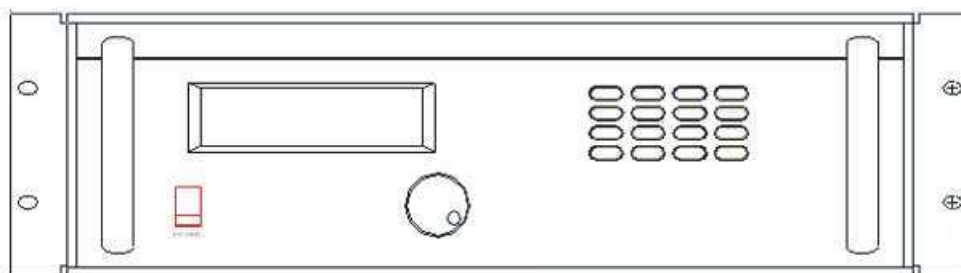
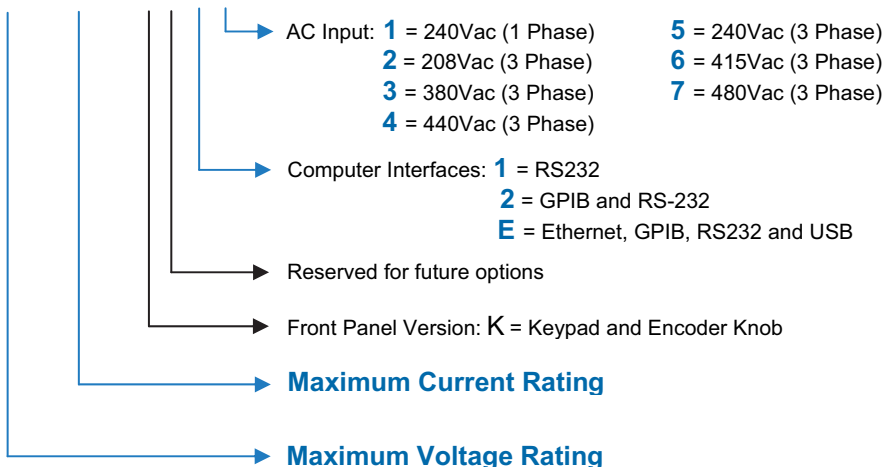

FRONT VIEW OF K-PANEL VERSION

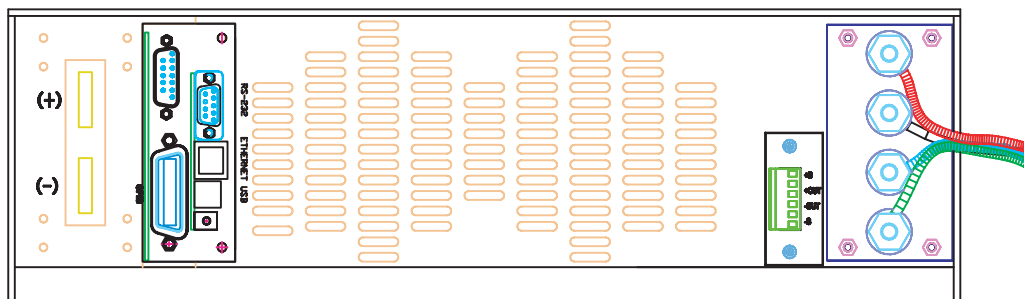

REAR VIEW

Common Features for ALL PD Models

- Fast Transient Response – 50us
- Low Ripple and Noise (PARD)
- 16 bit Digital Design Displays both voltage and current measurements, OVP, OCP, V_{LIST} , I_{LIST} , and other system indicator on an LCD display simultaneously without the need for external DMM or monitoring
- Front Panel Keypad for precise and easy-to-operate setting of the output voltage, current and other system functions
- Automatic Crossover of Constant Current or Constant Voltage Mode.
- Embedded RS-232 and IEEE488.2 SCPI/GPIB Standard and Optional Ethernet or USB-only Control for flexible remote digital programming and read back
- Optional RS-485 for Master/Slave Paralleling & to control multiple blocks of identically rated power supplies with a single PC interface connection
- V_{LIST} and I_{LIST} in Stepping Mode, PD Series to generate customized sequence of different output level up to maximum of 20 steps (points), with dwell times from 10ms to 1 minute stored in 4 profiles (This sequence can be cycled once or to a user-defined number of cycles)
- High-speed and Ultra-precision Design with 0.04% measurement accuracy and 0.1mA/0.5mV resolution (not applicable to all models)
- Programmable OVP (Over-voltage Protection) & OCP (Over-current Protection), Redundant OTP (Over-temperature Protection), UVP (Under-voltage Protection), Remote Lockout (for I_{LIST} , V_{LIST} and ATE), Fan-speed Control
- Remote Sensing to compensate for measurement errors due to large line drops
- Electronic Remote/Local Closed-cased Calibration
- Active Down Programming Control for fast down programming speed
- Polarity Reversal & Isolation Output Relays available
- LabVIEW/LabWindows Drivers
- Local/Remote Voltage and Current Limit Programming with selectable programming ranges (Optional)
- TTL Function to enable/disable the power supply output. (Optional)
- External Analog Voltage (0 to +10Vdc) Input for the programming voltage/current output (Optional)
- Multi-channel systems available, up to 8 channels per chassis. (PDS Models)
- Modified & Customized Solutions such as higher voltage/current ratings

E- Option Model Features (Keypad, Encoder, Ethernet)

- Digital Encoder & Full Functional Keypad for real-time programmatic control
- Ethernet and RS-485 available for system-level expansion & integration
- Standard Tracking Feature for multi-channel synchronized control
- USB-only Interface available



PDS Model Features (Multi-channel)



- More Choices - the only linear supply providing up to 350Vdc, 50A dc @ maximum power of up to 1.75 ~ 2kW in a single 4U 19" inch rackmount box
- More Flexibility - customize the voltage/power/current rating of numerous single supplies and combine them into a single system with up to 8 channels per 4U box
- More Expandability - Master/Slave Parallel multiple identically-rated systems & control up to 32 channels as a single unit via one GPIB, RS-232, or RS-485 address

MODEL ¹	VOLTAGE OUTPUT 0-Vdc Max.	CURRENT OUTPUT 0-Adc Max.	PROGRAMMING				OVER-VOLTAGE PROTECTION Voltage(V) ¹⁰	READBACK	
			Resolution ²		Accuracy ¹⁰			Resolution ²	
			Voltage (mV)	Current (mA)	Voltage (mV)	Current (mA)		Voltage (mV)	Current (mA)
PD5-3	5	3	0.5	0.3	0.02% + 1.5	0.03% + 0.9	0.2%+0.3%	0.5	0.3
PD5-10	5	10	0.5	1	0.02% + 1.5	0.03% + 3.0	0.2%+0.3%	0.5	1
PD5-12	5	12	0.5	1.2	0.02% + 1.5	0.03% + 3.6	0.2%+0.3%	0.5	1.2
PD5-20	5	20	0.5	2	0.02% + 1.5	0.03% + 6.0	0.2%+0.3%	0.5	2
PD5-24	5	24	0.5	2.4	0.02% + 1.5	0.03% + 7.2	0.2%+0.3%	0.5	2.4
PD5-30	5	30	0.5	3	0.02% + 1.5	0.03% + 9.0	0.2%+0.3%	0.5	3
PD5-40	5	40	0.5	4	0.02% + 1.5	0.03% + 12	0.2%+0.3%	0.5	4
PD8-2	8	2	0.8	0.2	0.02% + 2.4	0.03% + 0.6	0.2%+0.3%	0.8	0.2
PD8-4	8	4	0.8	0.4	0.02% + 2.4	0.03% + 1.2	0.2%+0.3%	0.8	0.4
PD8-10	8	10	0.8	1	0.02% + 2.4	0.03% + 3.0	0.2%+0.3%	0.8	1
PD 8-20	8	20	0.8	2	0.02% + 2.4	0.03% + 6.0	0.2%+0.3%	0.8	2
PD8-40	8	40	0.8	4	0.02% + 2.4	0.03% + 12	0.2%+0.3%	0.8	4
PD20-1	20	1	2	0.1	0.02% + 6.0	0.03% + 0.3	0.2%+0.3%	2	0.1
PD20-2	20	2	2	0.2	0.02% + 6.0	0.03% + 0.6	0.2%+0.3%	2	0.2
PD20-3	20	3	2	0.3	0.02% + 6.0	0.03% + 0.9	0.2%+0.3%	2	0.3
PD20-4	20	4	2	0.4	0.02% + 6.0	0.03% + 1.2	0.2%+0.3%	2	0.4
PD20-5	20	5	2	0.5	0.02% + 6.0	0.03% + 1.5	0.2%+0.3%	2	0.5
PD20-10	20	10	2	1	0.02% + 6.0	0.03% + 3.0	0.2%+0.3%	2	1
PD20-30	20	30	2	3	0.02% + 6.0	0.03% + 9.0	0.2%+0.3%	2	3
PD20-50	20	50	2	5	0.02% + 6.0	0.03% + 15	0.2%+0.3%	2	5
PD30-0.6	30	0.6	3	0.1	0.02% + 9.0	0.03% + 0.2	0.2%+0.3%	3	0.1
PD30-1.2	30	1.2	3	0.2	0.02% + 9.0	0.03% + 0.4	0.2%+0.3%	3	0.2
PD30-2	30	2	3	0.2	0.02% + 9.0	0.03% + 0.6	0.2%+0.3%	3	0.2
PD30-2.5	30	2.5	3	0.3	0.02% + 9.0	0.03% + 0.8	0.2%+0.3%	3	0.3
PD30-5	30	5	3	0.5	0.02% + 9.0	0.03% + 1.5	0.2%+0.3%	3	0.5
PD30-10	30	10	3	1	0.02% + 9.0	0.03% + 3.0	0.2%+0.3%	3	1
PD35-2.0	35	2	3.5	0.2	0.02% + 10.5	0.03% + 0.6	0.2%+0.3%	3.5	0.2
PD40-0.5	40	0.5	4	0.1	0.02% + 12.0	0.03% + 0.2	0.2%+0.3%	4	0.1
PD40-1	40	1	4	0.1	0.02% + 12.0	0.03% + 0.3	0.2%+0.3%	4	0.1
PD40-1.5	40	1.5	4	0.2	0.02% + 12.0	0.03% + 0.5	0.2%+0.3%	4	0.2
PD40-2	40	2	4	0.2	0.02% + 12.0	0.03% + 0.6	0.2%+0.3%	4	0.2
PD40-3.5	40	3.5	4	0.4	0.02% + 12.0	0.03% + 1.1	0.2%+0.3%	4	0.4
PD40-7	40	7	4	0.7	0.02% + 12.0	0.03% + 2.1	0.2%+0.3%	4	0.7
PD40-6	40	6	4	0.6	0.02% + 12.0	0.03% + 1.8	0.2%+0.3%	4	0.6
PD60-0.3	60	0.3	6	0.1	0.02% + 18.0	0.03% + 0.1	0.2%+0.3%	6	0.1
PD60-1	60	1	6	0.1	0.02% + 18.0	0.03% + 0.3	0.2%+0.3%	6	0.1
PD60-3	60	3	6	0.3	0.02% + 18.0	0.03% + 0.9	0.2%+0.3%	6	0.3
PD60-6	60	6	6	0.6	0.02% + 18.0	0.03% + 1.8	0.2%+0.3%	6	0.6
PD60-10	60	10	6	1	0.02% + 18.0	0.03% + 3.0	0.2%+0.3%	6	1
PD60-20	60	20	6	2	0.02% + 18.0	0.03% + 6.0	0.2%+0.3%	6	2
PD80-0.25	80	0.25	8	0.1	0.02% + 24.0	0.03% + 0.1	0.2%+0.3%	8	0.1
PD80-2.5	80	2.5	8	0.3	0.02% + 24.0	0.03% + 0.8	0.2%+0.3%	8	0.3
PD80-3.5	80	3.5	8	0.4	0.02% + 24.0	0.03% + 1.1	0.2%+0.3%	8	0.4
PD120-0.3	120	0.3	12	0.1	0.02% + 36.0	0.03% + 0.1	0.2%+0.3%	12	0.1
PD120-0.5	120	0.5	12	0.1	0.02% + 36.0	0.03% + 0.2	0.2%+0.3%	12	0.1
PD120-0.5	120	0.5	12	0.1	0.02% + 36.0	0.03% + 0.2	0.2%+0.3%	12	0.1
PD120-1	120	1	12	0.1	0.02% + 36.0	0.03% + 0.3	0.2%+0.3%	12	0.1
PD120-2	120	2	12	0.2	0.02% + 36.0	0.03% + 0.6	0.2%+0.3%	12	0.2
PD250-0.2	250	0.2	25	0.1	0.03% + 100	0.03% + 0.1	0.2%+0.3%	25	0.1
PD250-0.4	250	0.4	25	0.1	0.03% + 100	0.03% + 0.1	0.2%+0.3%	25	0.1
PD250-0.6	250	0.6	25	0.1	0.03% + 100	0.03% + 0.2	0.2%+0.3%	25	0.1

Temperature Coefficient⁸: Constant Voltage - 100 ppm/°C Constant Current - 200 ppm/°C

Output Isolation: Vout < 350Vdc: ± 500Vdc / Vout < 120Vdc: ± 240Vdc

AC Input⁹: 103.5 ~ 126.5Vac or 207 ~ 253Vac @ 50/60Hz

Load Transient Response Time⁶: 50 µs

*1: All electronic specifications are represented at the full operating temperature range for all models.

*2: The programming and readback resolutions are based on 16 bit resolution design.

*3: Load regulation specifications are for 10 - 90% load changes.

*4: Line regulation specifications are for input voltage variation over the AC input voltage range with constant rated load.

*5: Ripple and Noise (PARD) specifications are for 10 - 100% output voltage and full output current.

READBACK		REGULATION			PARD ⁵	DRIFT (STABILITY) ¹⁰		PROGRAM ⁷
Accuracy ¹⁰		Load ³		Line ⁴	CV/CC			
Voltage (mV)	Current (mA)	CV (mV)	CC (mA)	CV/CC	mVrms/mV _{PK-PK}	CV (mV)	CC (mA)	T _{UP} /T _{DN}
0.02% + 1.5	0.02% + 0.9	0.001% + 1	0.01% + 1	1mV/1mA	0.3/3	0.01% + 0.3	0.1% + 0.20	10/10ms
0.02% + 1.5	0.02% + 3.0	0.001% + 1	0.01% + 1	1mV/1mA	0.3/3	0.01% + 0.3	0.1% + 0.50	10/10ms
0.02% + 1.5	0.02% + 3.6	0.001% + 1	0.01% + 1	1mV/1mA	0.3/3	0.01% + 0.3	0.1% + 0.60	10/10ms
0.02% + 1.5	0.02% + 6.0	0.001% + 1	0.01% + 1	1mV/1mA	0.3/3	0.01% + 0.3	0.1% + 1.00	10/10ms
0.02% + 1.5	0.02% + 7.2	0.001% + 1	0.01% + 1	1mV/1mA	0.3/3	0.01% + 0.3	0.1% + 1.20	10/10ms
0.02% + 1.5	0.02% + 9.0	0.001% + 1	0.01% + 1	1mV/1mA	0.3/3	0.01% + 0.3	0.1% + 1.50	10/10ms
0.02% + 1.5	0.02% + 12.0	0.001% + 1	0.01% + 1	1mV/1mA	0.3/3	0.01% + 0.3	0.1% + 2.00	10/10ms
0.02% + 2.4	0.02% + 0.6	0.001% + 1	0.01% + 1	1mV/1mA	0.3/3	0.01% + 0.4	0.1% + 0.10	10/10ms
0.02% + 2.4	0.02% + 1.2	0.001% + 1	0.01% + 1	1mV/1mA	0.3/3	0.01% + 0.4	0.1% + 0.20	10/10ms
0.02% + 2.4	0.02% + 3.0	0.001% + 1	0.01% + 1	1mV/1mA	0.3/3	0.01% + 0.4	0.1% + 0.50	10/10ms
0.02% + 2.4	0.02% + 6.0	0.001% + 1	0.01% + 1	1mV/1mA	0.3/3	0.01% + 0.4	0.1% + 1.00	10/10ms
0.02% + 2.4	0.02% + 12.0	0.001% + 1	0.01% + 1	1mV/1mA	0.3/3	0.01% + 0.4	0.1% + 2.00	10/10ms
0.02% + 6.0	0.02% + 0.3	0.001% + 1	0.01% + 1	1mV/1mA	0.3/3	0.01% + 1	0.1% + 0.10	30/40ms
0.02% + 6.0	0.02% + 0.6	0.001% + 1	0.01% + 1	1mV/1mA	0.3/3	0.01% + 1	0.1% + 0.10	30/40ms
0.02% + 6.0	0.02% + 0.9	0.001% + 1	0.01% + 1	1mV/1mA	0.3/3	0.01% + 1	0.1% + 0.20	30/40ms
0.02% + 6.0	0.02% + 1.2	0.001% + 1	0.01% + 1	1mV/1mA	0.3/3	0.01% + 1	0.1% + 0.20	30/40ms
0.02% + 6.0	0.02% + 1.5	0.001% + 1	0.01% + 1	1mV/1mA	0.3/3	0.01% + 1	0.1% + 0.30	30/40ms
0.02% + 6.0	0.02% + 3.0	0.001% + 1	0.01% + 1	1mV/1mA	0.3/3	0.01% + 1	0.1% + 0.50	30/40ms
0.02% + 6.0	0.02% + 9.0	0.001% + 1	0.01% + 1	1mV/1mA	0.3/3	0.01% + 1	0.1% + 1.50	30/40ms
0.02% + 6.0	0.02% + 15.0	0.001% + 1	0.01% + 1	1mV/1mA	0.3/3	0.01% + 1	0.1% + 2.50	30/40ms
0.02% + 9.0	0.02% + 0.2	0.001% + 1	0.01% + 1	1mV/1mA	0.6/3	0.01% + 1.5	0.1% + 0.10	30/40ms
0.02% + 9.0	0.02% + 0.4	0.001% + 1	0.01% + 1	1mV/1mA	0.6/3	0.01% + 1.5	0.1% + 0.10	30/40ms
0.02% + 9.0	0.02% + 0.6	0.001% + 1	0.01% + 1	1mV/1mA	0.6/3	0.01% + 1.5	0.1% + 0.10	30/40ms
0.02% + 9.0	0.02% + 0.8	0.001% + 1	0.01% + 1	1mV/1mA	0.6/3	0.01% + 1.5	0.1% + 0.20	30/40ms
0.02% + 9.0	0.02% + 1.5	0.001% + 1	0.01% + 1	1mV/1mA	0.6/3	0.01% + 1.5	0.1% + 0.30	30/40ms
0.02% + 9.0	0.02% + 3.0	0.001% + 1	0.01% + 1	1mV/1mA	0.6/3	0.01% + 1.5	0.1% + 0.50	30/40ms
0.02% + 10.5	0.02% + 0.6	0.001% + 1	0.01% + 1	1mV/1mA	0.6/3	0.01% + 1.8	0.1% + 0.10	30/40ms
0.02% + 12.0	0.02% + 0.2	0.001% + 1	0.01% + 1	1mV/1mA	0.6/3	0.01% + 2	0.1% + 0.10	30/40ms
0.02% + 12.0	0.02% + 0.3	0.001% + 1	0.01% + 1	1mV/1mA	0.6/3	0.01% + 2	0.1% + 0.10	30/40ms
0.02% + 12.0	0.02% + 0.5	0.001% + 1	0.01% + 1	1mV/1mA	0.6/3	0.01% + 2	0.1% + 0.10	30/40ms
0.02% + 12.0	0.02% + 0.6	0.001% + 1	0.01% + 1	1mV/1mA	0.6/3	0.01% + 2	0.1% + 0.10	30/40ms
0.02% + 12.0	0.02% + 1.1	0.001% + 1	0.01% + 1	1mV/1mA	0.6/3	0.01% + 2	0.1% + 0.20	30/40ms
0.02% + 12.0	0.02% + 2.1	0.001% + 1	0.01% + 1	1mV/1mA	0.6/3	0.01% + 2	0.1% + 0.40	30/40ms
0.02% + 12.0	0.02% + 1.8	0.001% + 1	0.01% + 1	1mV/1mA	0.6/3	0.01% + 2	0.1% + 0.30	30/40ms
0.02% + 18.0	0.02% + 0.1	0.001% + 1	0.01% + 1	1mV/1mA	0.6/3	0.01% + 3	0.1% + 0.10	30/40ms
0.02% + 18.0	0.02% + 0.3	0.001% + 1	0.01% + 1	1mV/1mA	0.6/3	0.01% + 3	0.1% + 0.10	30/40ms
0.02% + 18.0	0.02% + 0.9	0.001% + 1	0.01% + 1	1mV/1mA	0.6/3	0.01% + 3	0.1% + 0.20	30/40ms
0.02% + 18.0	0.02% + 1.8	0.001% + 1	0.01% + 1	1mV/1mA	0.6/3	0.01% + 3	0.1% + 0.30	30/40ms
0.02% + 18.0	0.02% + 3.0	0.001% + 1	0.01% + 1	1mV/1mA	0.6/3	0.01% + 3	0.1% + 0.50	30/40ms
0.02% + 18.0	0.02% + 6.0	0.001% + 1	0.01% + 1	1mV/1mA	0.6/3	0.01% + 3	0.1% + 1.00	30/40ms
0.02% + 24.0	0.02% + 0.1	0.001% + 1	0.01% + 1	1mV/1mA	1/6	0.01% + 4	0.1% + 0.10	30/40ms
0.02% + 24.0	0.02% + 0.8	0.001% + 1	0.01% + 1	1mV/1mA	1/6	0.01% + 4	0.1% + 0.20	30/40ms
0.02% + 24.0	0.02% + 1.1	0.001% + 1	0.01% + 1	1mV/1mA	1/6	0.01% + 4	0.1% + 0.20	30/40ms
0.02% + 36.0	0.02% + 0.1	0.001% + 1	0.01% + 1	1mV/1mA	1/6	0.01% + 6	0.1% + 0.10	30/40ms
0.02% + 36.0	0.02% + 0.2	0.001% + 1	0.01% + 1	1mV/1mA	1/6	0.01% + 6	0.1% + 0.10	30/40ms
0.02% + 36.0	0.02% + 0.2	0.001% + 1	0.01% + 1	1mV/1mA	1/6	0.01% + 6	0.1% + 0.10	30/40ms
0.02% + 36.0	0.02% + 0.3	0.001% + 1	0.01% + 1	1mV/1mA	1/6	0.01% + 6	0.1% + 0.10	30/40ms
0.02% + 36.0	0.02% + 0.6	0.001% + 1	0.01% + 1	1mV/1mA	1/6	0.01% + 6	0.1% + 0.10	30/40ms
0.03% + 75.0	0.03% + 0.1	0.001% + 1	0.01% + 1	1mV/1mA	2/15	0.01% + 13	0.1% + 0.10	150/170ms
0.03% + 75.0	0.03% + 0.1	0.001% + 1	0.01% + 1	1mV/1mA	2/15	0.01% + 13	0.1% + 0.10	150/170ms
0.03% + 75.0	0.03% + 0.2	0.001% + 1	0.01% + 1	1mV/1mA	2/15	0.01% + 13	0.1% + 0.10	150/170ms

*6: Time for output voltage to recover to within +/- 0.5% of V_{FULL-SCALE} following a 10% ~ 60% load current change.

*7: Programming speed specifications are for 50% of full current loading.

*8: Temperature coefficient specifies output change per °C in ambient temp. rise following 30 min. warm up, w/ constant line & load.

*9: AC Input is fixed and factory configured to either 103.5 ~ 126.5Vac or 207 ~ 253Vac @ 50/60Hz.

*10: Over-voltage Protection, Readback & Programming Accuracy, Load/Line Regulation and CV/CC Drift are specified as Reading/Setting + Full Scale.

*11: Dual Channel PD Models are also available.

PDX XXX-XX X X X

- Output Isolation/Polarity Reversal Relays; **R** = Included
= Leave blank if not included
- Remote Computer Interfaces: **A** = GPIB and RS-232
E = Ethernet, GPIB, and RS-232
- Number of Outputs: **D** = Dual Outputs
= Leave blank for single output
- **Maximum Current**
- **Maximum Voltage**
- External Analog (0-10V) Control Interface: **A** = Included
= Leave blank if not included

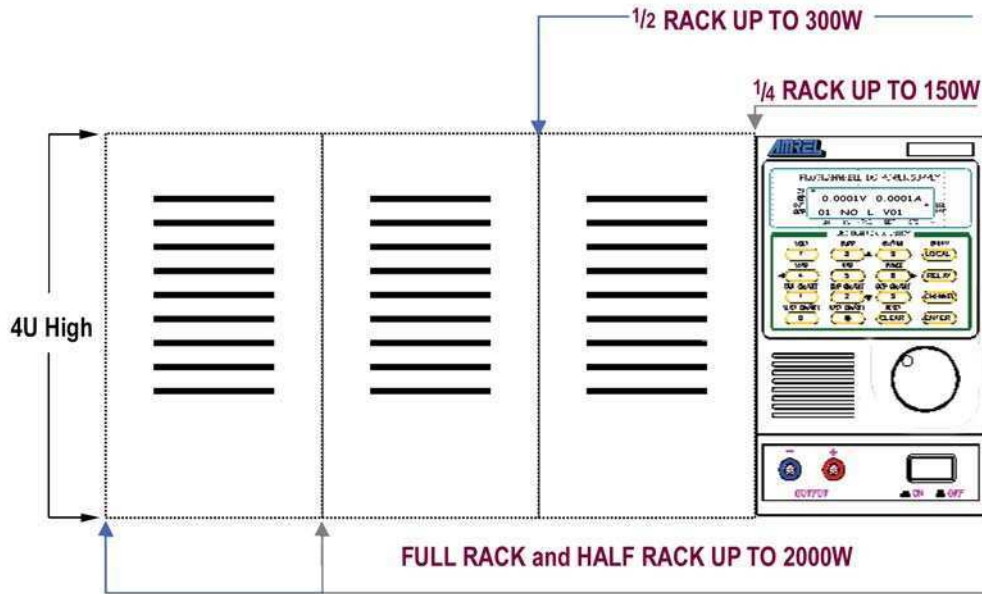

PD SERIES

RACKMOUNT CONFIGURATIONS

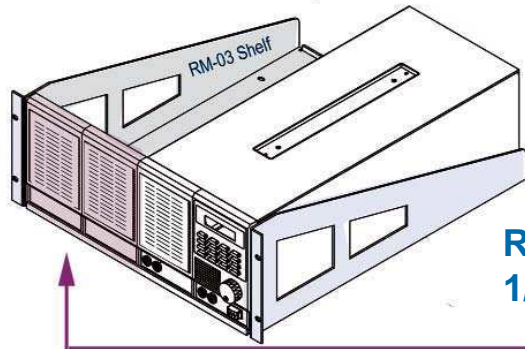

RMP-02A
1/2 Rack Filler Panel

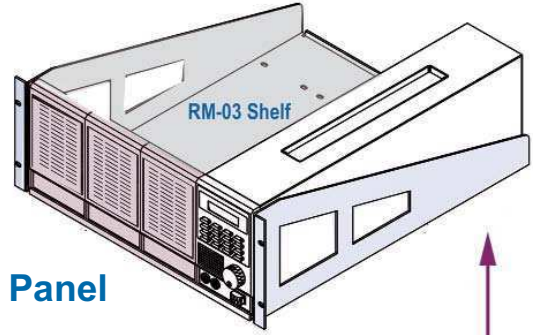

RMP-03A
3/4 Rack Filler Panel

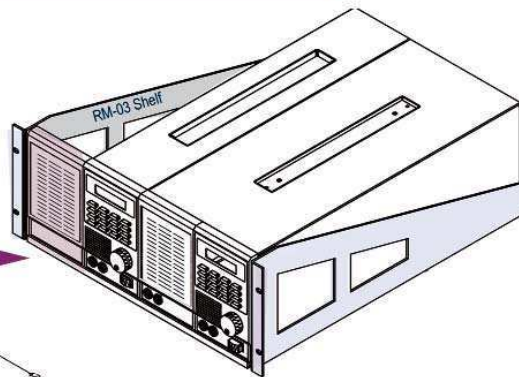

RMP-01A
1/4 Rack Filler Panel

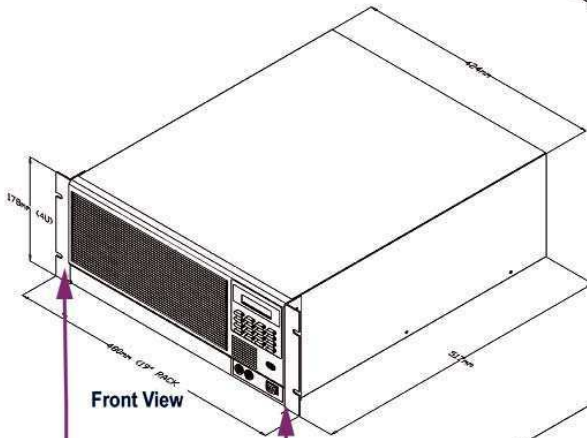

****RMP-04 Full Rack
Ear and
Rear Mount**

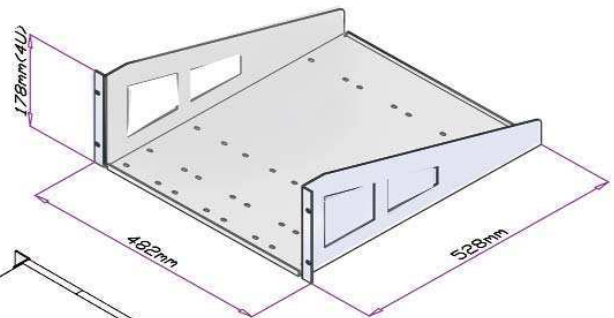

***RM-03 19"
Rackmount Shelf**

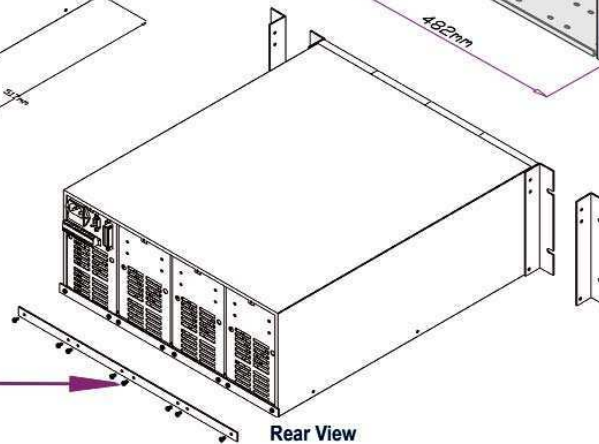

Please Note: All full rack units come standard with rack mounting ears.

*When assembled the RM-03 rack shelf adds approximately 3mm to the 4U height, resulting in 5U of required rack space. If space is limited to 4U, use the RMP-04.

**The RMP-04 must be factory assembled and requires a full rack width for mounting.

Configuration 1

Cost-effective Network Solution Utilizing AMREL's MC-2 Controller

MC-2 Features Include:

Flexibility & Simple Integration

- Field-expandable up to 32 units via RS-485 interface
- Control any AMREL Power Supply which includes RS-485 Interface
- Standardized set of SCPI Commands for AMREL SPS Power Supplies
- RS-232, GPIB, and Ethernet (option) connectivity to PC

Cost-Effective

- Control 31 AMREL SPS power supplies with a single controller unit
- Closed-cased Calibration for increased ROI
- Decrease costs of purchasing separate test systems by Mixing and Matching units to meet diverse application requirements in a single test system

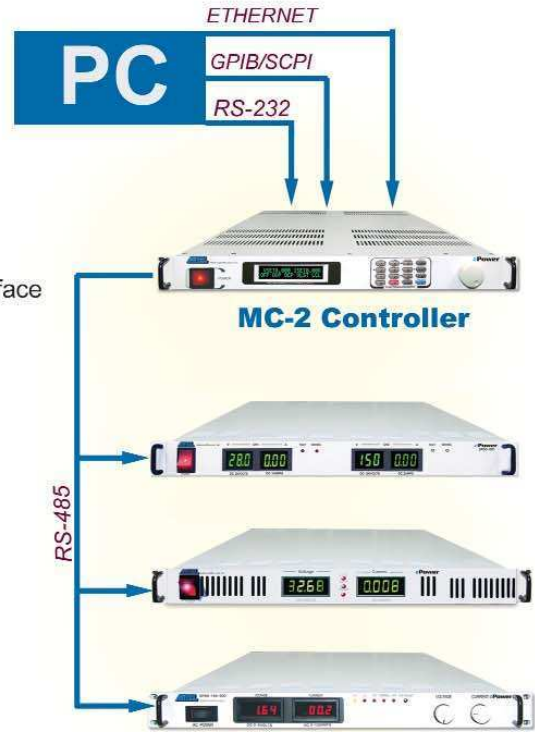

Configuration 2

Parallel System Network Solution Utilizing the SPS 1.2kW V-Panel Switch Mode Power Supply

Features Include:

Simple Parallel Integration

- Parallel units in groups and control as a single unit
- Auto-current balancing to share load equally
- Complete Parallel Commands for System-level parallel configuration

Reliability, Connectivity and Hassle-free Maintenance

- Front and Side air vents for optimized air flow
- RS-232, GPIB and Ethernet (Option) connectivity to PC
- Closed-cased calibration without removing the unit from rack

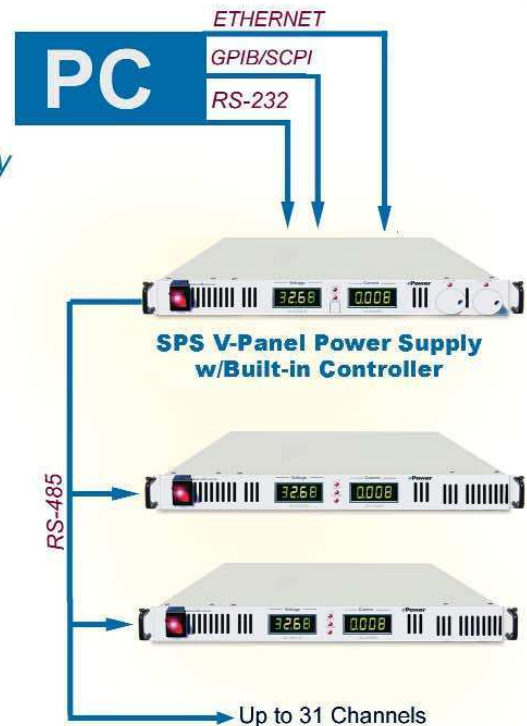

Configuration 3

Low-power & Multiple Channel Network Solution Utilizing the SPD Dual Channel Switch Mode Power Supply

Features Include:

Rack & Stack Multiple Channels

- RS-232, GPIB and Ethernet (Option) connectivity for central remote operation
- Control units in groups for effortless setting configuration
- Remote Inhibit and External Fault indicator allows simple integration of system-level interlock protection

Space and Investment Saver

- Dual output in a single 1U 19 inch chassis
- Satisfy low-power requirements up to 360W without purchasing expensive higher-powered equipment
- Closed-cased calibration without removing the unit from rack

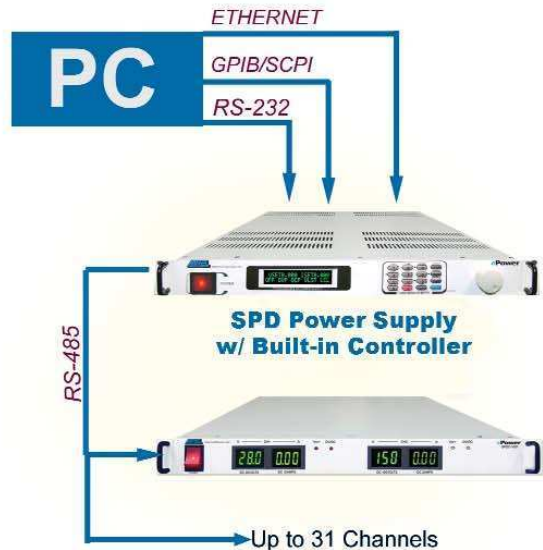

Configuration 4:

Unlimited Ethernet Connectivity Solution

MCU-2 Features:

Expandability, Reliability & Scalable Systems

- Ethernet connectivity allows wired or wireless control of power systems
- Easily build isolated Instrumentation Networks of power supplies without the dangers of unauthorized access
- Integrate new units into system via simple Ethernet protocols and DHCP

Flexible Systems and System Integration

- Only a single GPIB, RS-232, USB or Ethernet connection is required for remote PC control
- SCPI commands and unique addressing methods allow simple system integration and application programming
- Control up to 800+ AMREL Ethernet Power Supplies with added MCU-2 Controllers

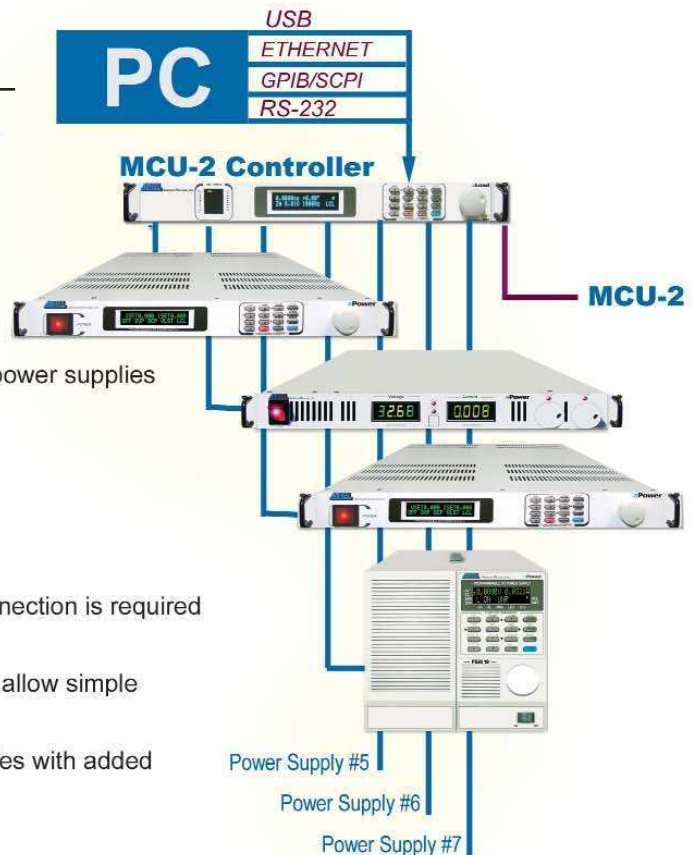

ePower MODIFICATIONS AND CUSTOMIZATIONS

AMREL's goal is to meet your instrumentation needs through standard, modified or custom product designs. In many cases, minor modifications may be proposed with little or no NRE. Whether it's a simple color change or a Electrical/Mechanical re-design, AMREL's engineering team can provide the solution.

AMREL is acutely aware that a customer's requirements may call for non-standard specifications. Our team of engineers leads the industry in providing custom power supply solutions from concept to integration. Ask us about our customized solutions program if your requirements cannot be met with a standard or modified ePower supply. We will review your specification and provide you with a complete technical concept including technical data and drawings. Whether your application calls for a low-power or high-power switch mode or linear power supply, you can be assured AMREL's team will provide the most effective yet economical solution available.

Below are samples of customizations and/or modifications available through AMREL's Custom Solutions Program.

- Non-standard Voltage and Current Output Ranges.
- Lower Ripple Noise (via additional filtering).
- Higher Programming/Readback Resolutions.
- Crowbar OVP Circuitry.
- Multiple Outputs in One Chassis.
- Non-standard I/O Connectors.
- Non-standard Front Panel Layouts.
- Increased Power Density Up to 1500W in a 1U High

SPRT - This fully customized switch mode power supply is packaged in a 1U high form factor, weighing approx. 10lbs. (net weight). The SPRT includes front panel I/O and ac input connectors.



PDS - The PDS is a full rack, multiple channel linear power supply.



SPDC1001 - This unit has two (2) 300 Watt outputs with different voltage and current ratings, packed in a 1U high chassis. The outputs are controlled via trimmer pots.



SPSX was developed for the Lockheed Martin LMSTAR Test Station. Changes to AMREL's standard SPS were made to meet the following requirements: One GPIB interface with only one address for the entire system. The power supplies were daisy chained to the master controller via a RS-485 Bus (Now standard). In addition, each power supply required built-in relays for polarity reversal and output isolation.



SPS 1.5kW - This unit packs 1500 Watt of output power in a 1U high chassis. It has a 208Vac-3Phase input, and includes GPIB and RS-232 Interfaces



Requesting a quote or ordering a product— **AMREL MAKES IT SIMPLE**

AMREL's Commitment to SERVICE and TECHNICAL SUPPORT has been adopted as a Corporate Mandate and an unwavering pledge to our customers.

AMREL knows that in this fast paced, high tech world, our customers have different requirements and preferences, that's why we have developed not only the most flexible product lines on the market today, but also flexible means in which our customers can communicate their needs to AMREL.

REQUESTING A QUOTE:

For customers who prefer speaking with a real person (and not a machine)

Call 1(800) 654-9838 within the U.S., between 8am-5pm pacific time M-F or 1(626) 443-6818 for International calls.

Just have time for a quick e-mail

Send your request for a quote to ariinfo@amrel.com - you will usually receive a response the same day, but no later than 24 hours.

If you are visiting AMREL's website at www.amrel.com and would like a quote

Go to the power products section of AMREL's website. Simply click on the *Request Information* button located in the left margin and complete the Request Form. To expedite processing, verbal or email requests are preferred.

Would you like to speak with a representative in your area?

Go to www.amrel.com and click on the power products section – click on the *Contact Us* button to locate the appropriate AMREL representative.

CUSTOM/SPECIAL PRODUCT REQUESTS:

The same options for "Requesting a Quote" apply to "Custom/Special Product Requests".

In addition, you will find a Request Customization button in the right margin of the power products web pages. Simply complete this form and submit – you will receive a response within 24 hours (M-F).

ORDER PLACEMENT:

Once you have received your quote, placing an order is simple.

There are two easy methods to choose from in placing an order:

- 1) **Call AMREL direct** at 1-800-654-9838 within the U.S or 1 (626) 443-6818 for International.
- 2) **Submit your Purchase Order** to AMREL by Faxing to 1(626) 443-8600 (U.S. or International), or E-mail to ariinfo@amrel.com, and then mail the hard copy to - AMERICAN RELIANCE INC, Attn: Sales Department, 3445 Fletcher Ave, El Monte, CA 91731

*****AMREL will provide an acknowledgement once your order has been verified and processed*****

ADDITIONAL INFORMATION:

Payment Terms: AMREL accepts Master Card, Visa Card, American Express, or NET 30 Terms approved accounts for domestic purchases. For international purchases, items must be paid for in advance via wire transfer or a Letter of Credit may be submitted. NET 30 Terms may be granted in some cases.

GSA Ordering: AMREL's products are listed under GSA Contract Number: #GS-24F-9037H. Please reference this number when placing an order under this contract.

Product Service and Support: In addition to providing quality products at competitive prices, it is AMREL's contention that after-sale **Customer Support** is what really makes the difference in developing and maintaining long-term, mutually rewarding relationships with your valued customers. Please contact our Technical Support Staff at 1-800-654-9838 for product servicing requests or technical questions.

AMREL'S eLoad line includes five series' of programmable electronic loads:

PLA Series of Air-Cooled Loads

- Market's Widest Selection of Available Models: 800W, 1.5kW, 2kW, 2.5kW, 3kW, 4kW, 5kW, 7.5kW, 10kW, 20kW (up to 100kW+ available upon request), up to 1000V and 2000A - Ultra-low Range Available
- Low-voltage Operation
- Closed-case Calibration
- Individual FET Protection
- Co-resident GPIB IEEE-488/RS-232 (Standard)
- USB and Embedded Ethernet Interfaces Available
- Oscillation Protection
- Five Operating Modes: CC, CR, CV, CP and Pulse
- Programmable Protection: OV/UV/OC/UC/OP/UP
- Dynamic Power Profiling (store up to 4 profiles)



PLW Series of Water-Cooled Loads

- Market's Widest Selection of Available Models: 6kW/9kW/12kW/18kW(2U) 24kW/36kW(4U) (up to 100kW+ available upon request), up to 1200V and 3000A (5000A Upon Request) Ultra-low Range Available
- Low-voltage Operation
- Closed-case Calibration
- Individual FET Protection
- Co-resident GPIB IEEE-488/RS-232 (Standard)
- USB and Embedded Ethernet Available
- Oscillation Protection
- Condensation Protection
- Highest Power Dissipation Density
- Five Operating Modes: CC, CR, CV, CP & Pulse
- Programmable Protection: OV/UV/OC/UC/OP/UP
- Dynamic Power Profiling (store up to 4 profiles)



LPL Series of Low-Profile Air-Cooled Loads

- Available 600W Models: 60V, 120V, 400V, 600V (all 1U high and Zero Stackable)
- Ultra-compact Design (1U)
- Low-voltage Operation
- Closed-case Calibration
- Individual FET Protection
- Full Front Panel Control
- GPIB IEEE-488/RS-232 (Standard)
- USB and Embedded Ethernet Available
- Oscillation Protection
- Dynamic Power Profiling (store up to 4 profiles)
- Programmable Protection: OV/UV/OC/UC/OP/UP



PEL Series of Low-Power Air-Cooled Loads

- Available Models: 60W, 150W, 300W, 600W
- Wide Range of Models
- Low-voltage Operation
- Closed-case Calibration
- GPIB IEEE-488 and RS-232 (Standard)
- Dynamic Power Profile (99 Points)
- Five Modes of Operation: CC, CR, CV, CP and Pulse
- Programmable Protection: OV/UV/OC/UC/OP/UP

FEL Series of Low-Voltage Air-Cooled Loads

- Available Models: 60W, 150W, 300W
- Ultra-low Voltage Operation
- Closed-case Calibration
- Co-resident GPIB IEEE-488/RS-232 (Standard)
- Dynamic Power Profile (99 Points)
- Full Front Panel Control
- Five Modes of Operation: CC, CR, CV, CP and Pulse
- Programmable Protection: OV/UV/OC/UC/OP/UP



Customization and Modification Available.

Additional products available that are not listed above include:

Zero-volt Load (ZVL) - 1/2 rack 4U box 40Adc (100W/200W), full rack 4U box 80Adc(300W), customized ratings available.

Frequency Response Analyzer (FRA) - at under \$5k, for many applications AMREL's FRA is a low cost, fully functional alternative to other high priced (up to \$20k) FRA's on the market.

Please Note: Specifications subject to change without notification.

3445 Fletcher Ave., El Monte, CA 91731 www.amrel.com
(U.S./Canada) 800 654-9838 Intl. 626 443-6818 ariinfo@amrel.com