

# **N9039A RF Preselector User's and Programmer's Guide**



**Manufacturing Part Number: N9039-90010  
Supersedes N9039-90009**

**Printed in USA**

**July 2009**

© Copyright 2007-2009 Agilent Technologies, Inc

---

## Notices

---

---

## Warranty

The material contained in this document is provided “as is,” and is subject to being changed, without notice, in future editions. Further, to the maximum extent permitted by applicable law, Agilent disclaims all warranties, either express or implied, with regard to this manual and any information contained herein, including but not limited to the implied warranties of merchantability and fitness for a particular purpose. Agilent shall not be liable for errors or for incidental or consequential damages in connection with the furnishing, use, or performance of this document or of any information contained herein. Should Agilent and the user have a separate written agreement with warranty terms covering the material in this document that conflict with these terms, the warranty terms in the separate agreement shall control.

---

## Technology Licenses

The hardware and/or software described in this document are furnished under a license and may be used or copied only in accordance with the terms of such license.

---

## Restricted Rights Legend

If software is for use in the performance of a U.S. Government prime contract or subcontract, Software is delivered and licensed as “Commercial computer software” as defined in DFAR 252.227-7014 (June 1995), or as a “commercial item” as defined in FAR 2.101(a) or as “Restricted computer software” as defined in FAR 52.227-19 (June 1987) or any equivalent agency regulation or contract clause. Use, duplication or disclosure of Software is subject to Agilent Technologies’ standard commercial license terms, and non-DOD Departments and Agencies of the U.S. Government will receive no greater than Restricted Rights as defined in FAR 52.227-19(c)(1-2) (June 1987). U.S. Government users will receive no greater than Limited Rights as defined in FAR 52.227-14 (June 1987) or DFAR 252.227-7015 (b)(2) (November 1995), as applicable in any technical data.

---

## Safety Notices

---

### WARNING

A *Warning* notice denotes a hazard. It calls attention to a procedure which, if not correctly performed or adhered to, could result in injury or loss of life. Do not proceed beyond a warning note until the indicated conditions are fully understood and met.

---

### CAUTION

A *Caution* notice denotes a hazard. It calls attention to a procedure that, if not correctly performed or adhered to, could result in damage to or destruction of the instrument. Do not proceed beyond a caution sign until the indicated conditions are fully understood and met.

---

## Copyright

©Agilent Technologies, Inc. 2007-2008

No part of this manual may be reproduced in any form or by any means (including electronic storage and retrieval or translation into a foreign language) without prior agreement and written consent from Agilent Technologies, Inc. as governed by United States and international copyright laws.

---

## General Safety Information

The following general safety precautions must be observed during all phases of operation. Failure to comply with these precautions or with specific warnings elsewhere in this manual violates safety standards of design, manufacture, and intended use of the instrument. Agilent Technologies assumes no liability for the customer's failure to comply with these requirements.

---

### WARNING

**This is a Safety Class 1 Product (provided with a protective earthing ground incorporated in the power cord). The mains plug shall only be inserted in a socket outlet provided with a protective earth contact. Any interruption of the protective conductor inside or outside of the product is likely to make the product dangerous. Intentional interruption is prohibited. (IEC 348 clauses 17.3.3c & 17.3.4)**

---

### CAUTION

This product is designed for use in Installation Category II and Pollution Degree 2 per IEC 61010 Second Edition and IEC 664 respectively.

---

**WARNING** If this product is not used as specified, the protection provided by the equipment could be impaired. This product must be used in a normal condition (in which all means for protection are intact) only.

---

---

**WARNING** No operator serviceable parts inside. Refer servicing to qualified personnel. To prevent electrical shock do not remove covers.

---

---

**CAUTION** The Mains wiring and connectors shall be compatible with the connector used in the premise electrical system. Failure, to ensure adequate earth grounding by not using the correct components may cause product damage, and serious injury

---

---

## Trademark Acknowledgement

Microsoft® Windows XP® is a US registered trademark of Microsoft Corp.

---

---

## Updated Information

Where to Find the Latest Information

Documentation is updated periodically. For the latest information about the N9039A RF Preselector, visit the following Internet URL  
:<http://www.agilent.com/find/n9039a>

---

---

## Compliance

This product has been designed and tested in accordance with accepted industry standards, and has been supplied in a safe condition. The documentation contains information and warnings that must be followed by the user to ensure safe operation and to maintain the product in a safe condition.

---

---

## Declaration of Conformity

The Declaration of Conformity (DOC) is on file. If a copy is required, contact an Agilent Sales Representative or the closest Agilent Sales Office. Alternately, contact Agilent at: <http://www.agilent.com>

---

## 1. Introducing the N9039A RF Preselector

## 2. Installation and Set Up

Initial Inspection . . . . .	16
Power Requirements . . . . .	18
AC Power Cord . . . . .	18
Instrument Location . . . . .	19
Turning on the RF Preselector the First Time. . . . .	20
Powering On the Instrument . . . . .	20
Accepting the End-User License Agreement (EULA) Screen . . . . .	20
Setting the System Date and Time . . . . .	21
Anti-virus Software and Firewalls . . . . .	21
Configuring the System . . . . .	22
Navigating Windows Without a Mouse . . . . .	23
Instrument Maintenance . . . . .	25
Cleaning the Instrument . . . . .	25
Cleaning Connectors . . . . .	25
Battery Information. . . . .	26
Protecting Against Electrostatic Discharge . . . . .	27
Trademark Acknowledgements . . . . .	28

## 3. Front and Rear Panel Features

Front Panel Features . . . . .	30
Display Annotations . . . . .	33
Screen Layout . . . . .	33
Measurement Display . . . . .	34
Rear-Panel Features . . . . .	35
Front and Rear Panel Symbols . . . . .	36
Packaging . . . . .	37

## 4. Instrument Configuration

Agilent Software Installed . . . . .	40
Customer Installation of Software . . . . .	41
User Accounts. . . . .	42
User Login. . . . .	42
AgilentOnly user account . . . . .	42
Agilent Service user accounts . . . . .	42
Customer creation of accounts . . . . .	43
Windows Configuration . . . . .	44
Settings That Can Be Changed . . . . .	44
Settings That Must Not Be Changed. . . . .	45

---

# Contents

Configuring Printers . . . . .	47
Configuring LAN . . . . .	48
Windows Security . . . . .	50
Windows Firewall . . . . .	51
Automatic Updates . . . . .	52
Virus Protection . . . . .	53
Spyware Protection . . . . .	53
System Maintenance . . . . .	54
System Restore . . . . .	54
Disk Defragmenting . . . . .	54
USB Connections . . . . .	55
Hard Drive Partitioning and Use . . . . .	56
Hard Drive Recovery Process . . . . .	57
Configuring Recovery Prompt Timing . . . . .	59
<b>5. Using Microsoft Windows XP</b>	
Remote Desktop: Using the N9039A Remotely . . . . .	62
Overview of Remote Desktop Operation . . . . .	62
Setting Up Remote Desktop Operation . . . . .	62
Running a Remote Desktop Session . . . . .	64
How To Locate the Computer Name of the Instrument . . . . .	68
Embedded Web Server: Using the N9039A Remotely . . . . .	69
Accessing the Instrument via the Internet: Overview . . . . .	69
How To Access the Instrument from the Internet . . . . .	69
Capturing/Printing Displays and Windows . . . . .	73
Windows Shortcuts and Miscellaneous Tasks . . . . .	74
Windows Shortcuts (Key Combinations) . . . . .	74
Windows Taskbar: Auto-hide . . . . .	76
The Windows Startup Folder . . . . .	77
<b>6. System Key</b>	
Show . . . . .	80
Errors . . . . .	80
System . . . . .	84
Hardware . . . . .	85
Alignments . . . . .	86
Show Alignment Statistics . . . . .	86
Restore Align Data . . . . .	87
IO Config . . . . .	88
GPIB Address . . . . .	88
Reset Web Password . . . . .	88
SCPI Socket Control Port (Remote Command Only) . . . . .	89

Query USB Connection (Remote Command Only) .....	89
USB Connection Status (Remote Command Only) .....	90
USB Packet Count (Remote Command Only) .....	90
Control Panel .....	92
Licensing .....	93
Diagnostics .....	94
Show Hardware Statistics .....	94
Remote Command Only Functions .....	96
Lock the Front Panel keys (Remote Command Only) .....	96
List installed Options (Remote Command Only) .....	96
Date (Remote Command Only) .....	97
Time (Remote Command Only) .....	97
Full Screen .....	97
<b>7. Preset Key</b>	
<b>8. IEEE Common Commands</b>	
IEEE Common Commands .....	102
Clear Status .....	102
Standard Event Status Enable .....	102
Standard Event Status Register Query .....	103
Identification Query .....	103
Operation Complete .....	104
Query Instrument Options .....	104
Reset .....	104
Service Request Enable .....	105
Status Byte Query .....	105
Wait-to-Continue .....	106
<b>9. Status Subsystem</b>	
STATus Subsystem (No equivalent front panel keys) .....	108
Detailed Description .....	108
STATus Subsystem Command Descriptions .....	119
<b>10. Troubleshooting</b>	
Check the Basics .....	130
Problems with Microsoft Windows XP .....	131
Returning the RF Preselector for Service .....	132
Locations for Agilent Technologies .....	132
Read the Warranty .....	132
Service Options .....	132

---

# Contents

Service Tag ..... 133  
Packaging the Instrument ..... 133

## 11. Specifications

N9039A RF Preselector Specifications ..... 136



---

## List of Commands

*CLS.....	102
*ESE <integer> .....	102
*ESE?.....	102
*ESR?.....	103
*IDN?.....	103
*OPC?.....	104
*OPC .....	104
*OPT?.....	104
*RST.....	104
*SRE <integer> .....	105
*SRE?.....	105
*STB?.....	105
*WAI.....	106
:CALibration:DATA:DEfault .....	87
:STATus:PRESet.....	119
:STATus:QUEStionable:CALibration:CONDition?.....	121
:STATus:QUEStionable:CALibration:ENABle <integer>.....	122
:STATus:QUEStionable:CALibration:ENABle? .....	122
:STATus:QUEStionable:CALibration:EXTended:NEEDed:CONDition? .....	124
:STATus:QUEStionable:CALibration:EXTended:NEEDed:ENABle <integer> .....	124
:STATus:QUEStionable:CALibration:EXTended:NEEDed:ENABle? .....	124
:STATus:QUEStionable:CALibration:EXTended:NEEDed:NTRansition <integer> .....	125
:STATus:QUEStionable:CALibration:EXTended:NEEDed:NTRansition? .....	125
:STATus:QUEStionable:CALibration:EXTended:NEEDed:PTRansition <integer>.....	126
:STATus:QUEStionable:CALibration:EXTended:NEEDed:PTRansition? .....	126
:STATus:QUEStionable:CALibration:EXTended:NEEDed[:EVENT]? .....	125
:STATus:QUEStionable:CALibration:NTRansition <integer> .....	123
:STATus:QUEStionable:CALibration:NTRansition?.....	123
:STATus:QUEStionable:CALibration:PTRansition <integer>.....	123
:STATus:QUEStionable:CALibration:PTRansition? .....	123
:STATus:QUEStionable:CALibration[:EVENT]? .....	122

---

## List of Commands

:STATus:QUEStionable:CONDition?	119
:STATus:QUEStionable:ENABle.	120
:STATus:QUEStionable:ENABle?	120
:STATus:QUEStionable:NTRansition?	120
:STATus:QUEStionable:NTRansition <integer>	120
:STATus:QUEStionable:POWer:CONDition?	126
:STATus:QUEStionable:POWer:ENABle <integer>	127
:STATus:QUEStionable:POWer:ENABle?	127
:STATus:QUEStionable:POWer:NTRansition <integer>	128
:STATus:QUEStionable:POWer:NTRansition?	128
:STATus:QUEStionable:POWer:PTRansition <integer>	128
:STATus:QUEStionable:POWer:PTRansition?>	128
:STATus:QUEStionable:POWer[:EVENT]?	127
:STATus:QUEStionable:PTRansition <integer>	121
:STATus:QUEStionable:PTRansition?	121
:STATus:QUEStionable[:EVENT]?	120
:SYSTem:COMMunicate:GPIB[1][:SELF]:ADDRes <integer>	88
:SYSTem:COMMunicate:GPIB[1][:SELF]:ADDRes?	88
:SYSTem:COMMunicate:LAN:SCPI:SOCKeT:CONTRol?	89
:SYSTem:COMMunicate:USB:CONNection?	89
:SYSTem:COMMunicate:USB:PACKets?	90
:SYSTem:COMMunicate:USB:STATus?	90
:SYSTem:DATE “<year>,<month>,<day>”	97
:SYSTem:DATE?	97
:SYSTem:ERRor:VERBoSe OFF ON 0 1	83
:SYSTem:ERRor:VERBoSe?	83
:SYSTem:ERRor[:NEXT]?	84
:SYSTem:KLOCK ON OFF 0 1	96
:SYSTem:KLOCK?	96
:SYSTem:OPTions?	96
:SYSTem:PON:ETIME?	95

---

## List of Commands

:SYSTem:PRESet . . . . .	99
:SYSTem:TEMPerature:HEXTreme? . . . . .	95
:SYSTem:TEMPerature:LEXTreme? . . . . .	95
:SYSTem:TIME “<hour>,<minute>,<second>” . . . . .	97
:SYSTem:TIME? . . . . .	97
DISPlay:FSCReen[:STATe] ON OFF 1 0 . . . . .	97



---

# 1 Introducing the N9039A RF Preselector

## Overview

The N9039A preselector is part of Agilent's CISPR-16 compliant measurement solution. The whole system works as a complete EMI receiver that utilizes the PSA as the receiver, the preselector as a filter before the PSA, and an external signal source used for alignment.

The preselector is used to prevent overload conditions of the PSA input mixer caused by broadband, impulse signals. This method improves the sensitivity of the system and reduces the amount of input attenuation needed.



---

## 2 Installation and Set Up

The N9039A RF Preselector hardware uses Microsoft® Windows XP® and is an open system.

The following topics can be found in this chapter:

- “Initial Inspection” on page 16
- “Power Requirements” on page 18
- “Instrument Location” on page 19
- “Turning on the RF Preselector the First Time” on page 20
- “Configuring the System” on page 22
- “Navigating Windows Without a Mouse” on page 23
- “Instrument Maintenance” on page 25
- “Protecting Against Electrostatic Discharge” on page 27
- “Trademark Acknowledgements” on page 28

---

**NOTE** The operating system settings have been optimized for the best performance. Modification of these settings may degrade instrument performance and measurement speed.

The N9039A is an Open Windows environment, so you can install non-approved software on the instrument. However, installation of non-approved software may affect instrument performance. Agilent does not warrant the performance with non-approved software installed.

---

## Initial Inspection

Inspect the shipping container and the cushioning material for signs of stress. Retain the shipping materials for future use, as you may wish to ship the RF Preselector to another location or to Agilent Technologies for service. Verify that the contents of the shipping container are complete.

Standard with All Instruments		
Item	Description	Quantity
User's Guide	Provides first-time power on instructions, licensing information, operating system information, and general hardware information.	1
Power Cable	Connection for instrument power.	1
USB Keyboard	USB Keyboard.	1
USB Mouse	USB Mouse.	1
Stacking Support Bracket Kit	Support brackets for connecting the preselector to the PSA when not being used in a rack mount configuration.	1

Optional Accessories		
Option	Contents	Quantity
<b>010</b> LAN Connection Kit	Cable Assembly - Shielded LAN	3
	Shielded 8 Port Network Switch	1
<b>011</b> LAN Connection Kit with GPIB Gateway	GPIB Cable - 0.5M	1
	Cable Assembly - Shielded LAN	3
	LAN/GPIB Gateway	1
	Shielded 8 Port Network Switch	1
<b>019</b> Type N Connector Cable Set	Type-N Coax Calibration Cable	1
	Cable Assembly - BNC(M) to BNC(M) 4 ft	3
	EMI system Type-N Semi Rigid Cable, Stacked	1
	EMI system Type-N Semi Rigid Cable, Racked	1
<b>027</b> 3.5 mm Connector Cable Set	Type-N Coax Calibration Cable.	1
	Cable Assembly - BNC(M) to BNC(M) 4 ft	3
	Adapter - 3.5 mm(F) to 3.5 mm(F)	1
	EMI system SMA Semi Rigid Cable, Stacked	1
	EMI system SMA Semi Rigid Cable, Racked	1



Optional Accessories		
Option	Contents	Quantity
<b>030</b> 2.4 mm Connector Cable Set	Adapter - 2.4 mm(F) to 3.5 mm(F).	1
	Type-N Coax Calibration Cable	1
	Cable Assembly - BNC(M) to BNC(M) 4 ft	3
	Adapter - 3.5 mm(F) to 3.5 mm(F)	1
	EMI system SMA Semi Rigid Cable, Stacked	1
	EMI system SMA Semi Rigid Cable, Racked	1
<b>1CM</b> Rackmount Kit	Rackmount Kit	1
<b>1CP</b> Rackmount Kit with Handles	Rackmount Kit with Handles	1

### Shipping Problems?

If the shipping materials are damaged or the contents of the container are incomplete:

- Contact the nearest Agilent Technologies office to arrange for repair or replacement (“[Returning the RF Preselector for Service](#)” on page 132). You will not need to wait for a claim settlement.
- Keep the shipping materials for the carrier’s inspection.
- If you must return an RF Preselector to Agilent Technologies, use the original (or comparable) shipping materials (see “[Returning the RF Preselector for Service](#)” on page 132).

## Power Requirements

When connecting the RF Preselector to a power source, the Line voltage does *not* need to be selected.

This RF Preselector does *not* contain customer serviceable fuses.

---

**WARNING** Failure to ground the RF Preselector properly can result in personal injury. Before turning on the RF Preselector, you must connect its protective earth terminals to the protective conductor of the main power cable. Insert the main power cable plug into a socket outlet that has a protective earth contact *only*. **DO NOT** defeat the earth-grounding protection by using an extension cable, power cable, or autotransformer without a protective ground conductor.

---

**CAUTION** This instrument has autoranging line voltage input. Be sure the supply voltage is within the specified range.

The Mains wiring and connectors shall be compatible with the connector used in the premise electrical system. Failure, to ensure adequate earth grounding by not using the correct components may cause product damage, and serious injury.

---

## AC Power Cord

The RF Preselector is equipped with a three-wire power cord, in accordance with international safety standards. This cable grounds the RF Preselector outside case when connected to an appropriate power line outlet. The cable appropriate to the original shipping location is included with the RF Preselector.

---

**WARNING** Install the instrument so that the detachable power cord is readily identifiable and easily reached by the operator. The detachable power cord is the instrument disconnecting device. It disconnects the mains circuits from the mains supply before other parts of the instrument. The front panel switch is only a standby switch and is not a LINE switch. Alternatively, an externally installed switch or circuit breaker (which is readily identifiable and is easily reached by the operator) may be used as a disconnecting device.

---

**CAUTION** Always use the three-prong AC power cord supplied with this product. Failure to ensure adequate earth grounding by not using this cord can cause product damage.

---

---

## Instrument Location

Make sure that both the fan inlet area and the exhaust vent area are not obstructed. The minimal clearance required is 2 inches for these vents on the sides of the instrument. Lack of adequate clearance can result in excessive audible noise. This is because airflow restrictions cause additional airflow noise and cause the fans to speed up so they can draw in enough air for the required cooling.

## Turning on the RF Preselector the First Time

Initial power-on requires:

- “Powering On the Instrument”
- “Accepting the End-User License Agreement (EULA) Screen”
- “Setting the System Date and Time”
- “Anti-virus Software and Firewalls”

---

**TIP** You can get automatic electronic notification of new firmware releases and other product updates and information by subscribing to the *Agilent Technologies Test & Measurement E-Mail Notification Service* for Agilent instruments at <http://www.agilent.com/find/notifyme>

---

### Powering On the Instrument

1. Position the instrument so that you have easy access to the power cord and plug it in. The main power cord can be used as the system disconnecting device. It disconnects the mains circuits from the mains supply.

---

**WARNING** **If this product is not used as specified, the protection provided by the equipment could be impaired. This product must be used in a normal condition (in which all means for protection are intact) only.**

---

2. Press the power switch (located in the lower left-hand corner of the RF Preselector’s front panel) to turn the RF Preselector on. See “[Front Panel Features](#)” on page 30.

---

**NOTE** Allow the RF Preselector to warm-up for 30 minutes. To meet its specifications, the RF Preselector must meet the operating temperature requirements.

---

### Accepting the End-User License Agreement (EULA) Screen

The License Agreement screen asks you to accept the terms of the End-User License Agreement for Windows XP. You must accept this agreement to continue the Windows XP installation and configuration. If you do not accept this agreement, the instrument shuts down and the next time you turn it on the Windows XP Setup Wizard starts from the beginning again.

For more information about the End-User License Agreement for Windows XP, see the Questions and answers about the End-User License Agreement topic in the Microsoft Windows XP Help and Support Center.

If you have connected a USB mouse, position the cursor appropriately and use the left mouse button to navigate the License Agreement screen.

If you do not have a mouse available to navigate the screen, use the instrument front panel keys as follows:

1. Press the **Tab** key to select the License Agreement text box.

2. Use the up and down arrow keys, or rotate the knob to read the agreement.
3. Press the **Tab** key again. This accesses I don't accept this agreement. You need to press the up arrow to select I accept this agreement.
4. Press **Select**, or **Tab** then **Enter** to finish this screen and move to the Date and Time Settings screen.

## Setting the System Date and Time

The Date and Time Settings screen is used to set the appropriate date, time and time zone. If you have connected a USB mouse, position the cursor and use the left mouse button to navigate the Date and Time Settings screen. Alternatively, the procedure for navigating this screen using a USB keyboard or the front panel is as follows:

1. Press the **Tab** (tab right or tab left) key to move between items in the Date and Time Settings screen. (The settings include the Date, Time, and Time Zone boxes, the Automatically adjust clock for daylight saving changes check box, and the **Next** button).
2. Use the left and right arrow keys to move between different parts of the item (for example, month, day, year, and hour, minute, seconds).
3. Use the up and down arrow keys to scroll through the different values available for the selected item (for example, month, day).
4. Use the **Space** key to select or clear the "Automatically adjust clock for daylight saving changes" check box when it is the active item.
5. When you have completed the date and time settings, press **Enter**, or **Tab** then **Enter** to finish this screen and continue the Windows XP Setup Wizard.

## Anti-virus Software and Firewalls

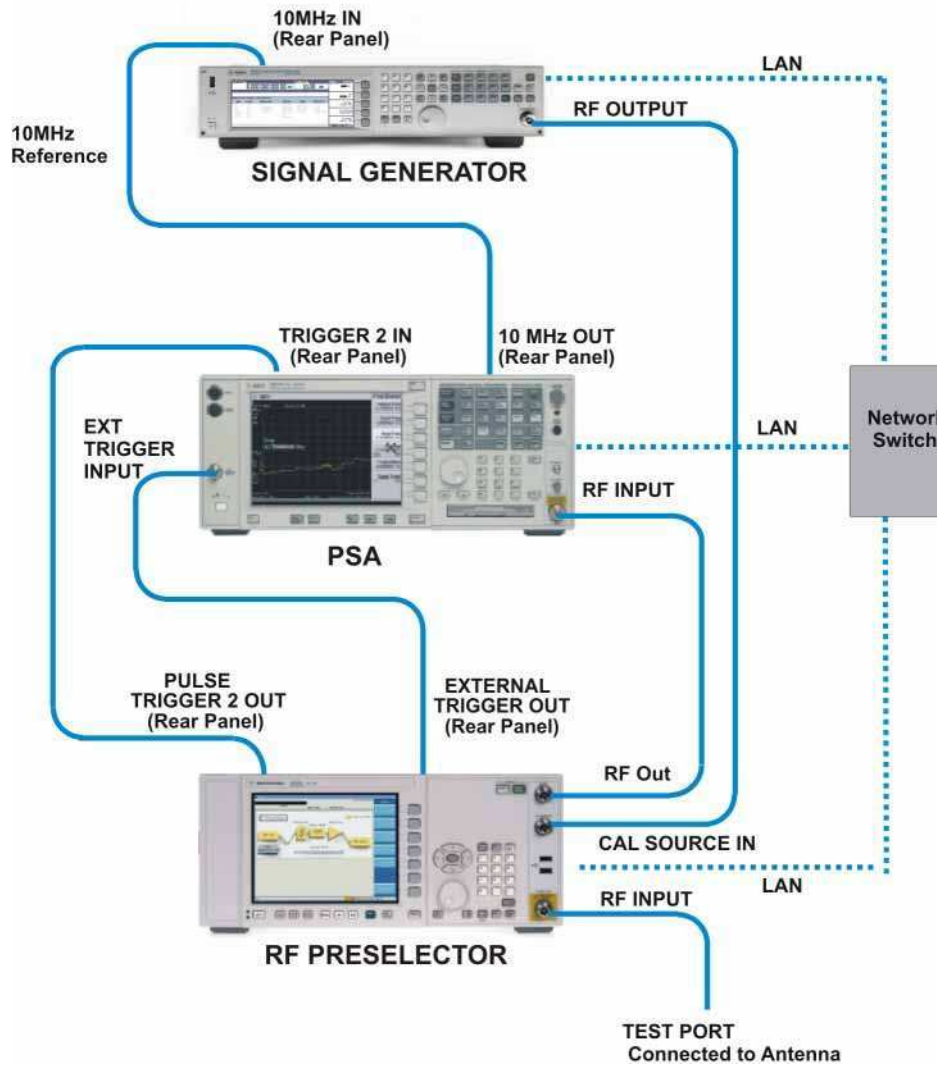
No anti-virus software is shipped with the instrument. It is recommended that you install anti-virus software if your instrument will be connected to the LAN. Check with your IT department for their recommendations. See the section "[3rd Party Software Verified by Agilent](#)" on page 41 for information about software that has been tested by Agilent.

The instrument is shipped with the Windows XP firewall enabled. Do not modify the default network settings as this may cause the instrument to not operate properly.

## Configuring the System

The RF Preselector is designed to be part of the Agilent EMI Measurement Receiver system. This system includes an Agilent PSA Series Spectrum Analyzer, the RF Preselector, an external signal generator used for alignment, and optional accessories needed to prepare the system for use.

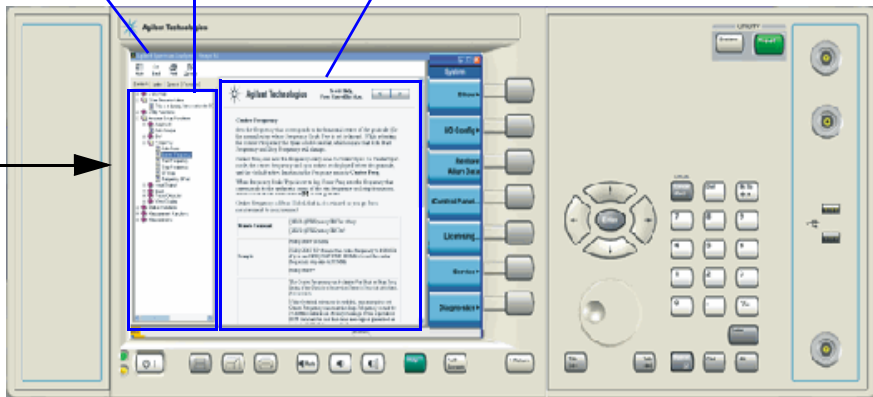






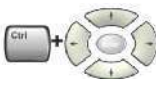
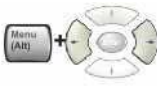


Figure 2-1. System Configuration



## Navigating Windows Without a Mouse

Key Presses	Actions
Esc	Exits/closes a Windows dialog box (does not exit an Application window)
Enter	Does the current "default action". If a menu item or a button is currently "highlighted", then the Enter key will activate that menu item or button.
Alt	Moves focus/control to the pull down menus bar in the active Window
Right Arrow	In pull-down menu: opens the next menu to the right, or opens a submenu In a dialog box: selects an option button
Left Arrow	In pull-down menu: opens the next menu to the left, or opens a submenu In dialog box: selects an option button
Up Arrow	In pull-down menu: Moves to next selection up in the menu In dialog box: selects an option button
Down Arrow	In pull-down menu: Moves to next selection down in the menu In dialog box: selects an option button
Tab	In dialog box: moves to the next/previous field
Del	Deletes the currently selected item
Alt + Tab	Switches between the next/previous Application
Alt + Enter	Shows the Properties of the currently selected item
Alt + Esc	Cycles through items in the order that they had been opened
Backspace	In My Computer or Windows Explorer: move up one level In Internet Explorer: works like the BACK arrow key
Ctrl + Left arrow	Moves to the left one word at a time
Ctrl + Right arrow	Moves to the right one word at a time
Ctrl + Tab	In dialog box: moves to the next/previous Tab location
Alt + Space	Opens the window control menu for the currently active window, allowing you to minimize, maximize, move and restore (size) the window
Ctrl + Esc	Opens the Windows Start Menu
Ctrl + Alt + Delete	Opens the Windows Task Manager

**Table 2-1. Using the Interactive Help System Without a Mouse**

<p>To open the Help window for any menu</p>	<p>Choose the desired menu, then press the front panel green Help key.</p>
<div style="display: flex; align-items: center;"> <div style="margin-right: 20px;"> <p><b>Navigation Tabs</b></p> <p><b>Navigation Pane</b></p> <p><b>Topic Pane</b></p> </div>  </div>	
<p>To toggle focus between the Navigation and topic panes</p>	<div style="display: flex; align-items: center;">  <p>Press the <b>Next Window</b> key</p> </div>
<p><b>In the Navigation Pane</b></p>	<p><b>In the Topic Pane</b></p>
<div style="display: flex; align-items: center;">  <p>To scroll up or down the topic list: Press the <b>Up</b> or <b>Down Arrow</b> key.</p> </div>	<div style="display: flex; align-items: center;">  <p>To scroll up or down : Press the <b>Up</b> or <b>Down Arrow</b> key.</p> </div>
<div style="display: flex; align-items: center;">  <p>To expand or collapse the tree for the selected topic: Press the <b>Right</b> or <b>Left Arrow</b> key.</p> </div>	<div style="display: flex; align-items: center;"> <div style="margin-right: 10px;">  </div> <p>To go to the next or previous page: Use the Tab keys to select the Right: or Left Pointer button (on the Topic Pane) Press <b>Enter</b>.</p> </div>
<div style="display: flex; align-items: center;">  <p>To display the selected topic: Press the <b>Enter</b> key.</p> </div>	
<div style="display: flex; align-items: center;">  <p>To scroll horizontally or vertically: Press <b>Ctrl+Left</b>, <b>Right</b>, <b>Up</b>, or <b>Down Arrow</b> keys.</p> </div>	<div style="display: flex; align-items: center;">  <p>To go back or forward: Press the <b>Alt+Left</b> or <b>Right Arrow</b> key.</p> </div>
<div style="display: flex; align-items: center;">  <p>To switch tabs: Press <b>Ctrl+Tab</b> keys.</p> </div>	
<div style="display: flex; align-items: center;">  </div>	<p>To close the Help window: Press the <b>Cancel (Esc)</b> key.</p>



---

## Instrument Maintenance

### Cleaning the Instrument

---

**WARNING** To prevent electrical shock, disconnect the Agilent Technologies model N9039A from mains before cleaning. Use a dry cloth or one slightly dampened with water to clean the external case parts. Do not attempt to clean internally.

---

### Cleaning Connectors

---

**CAUTION** Cleaning connectors with alcohol shall only be done with the instruments power cord removed, and in a well-ventilated area. Allow all residual alcohol moisture to evaporate, and the fumes to dissipate prior to energizing the instrument.

---

**WARNING** Keep isopropyl alcohol away from heat, sparks, and flame. Store in a tightly closed container. It is extremely flammable. In case of fire, use alcohol foam, dry chemical, or carbon dioxide; water may be ineffective.

Use isopropyl alcohol with adequate ventilation and avoid contact with eyes, skin, and clothing. It causes skin irritation, may cause eye damage, and is harmful if swallowed or inhaled. It may be harmful if absorbed through the skin. Wash thoroughly after handling.

In case of spill, soak up with sand or earth. Flush spill area with water.

Dispose of isopropyl alcohol in accordance with all applicable federal, state, and local environmental regulations.

---

---

## Battery Information

The RF Preselector uses a lithium battery located on the CPU board. This is not an operator replaceable part. See [“Returning the RF Preselector for Service” on page 132](#). Replaceable parts must be approved or supplied by Agilent Technologies.

You can order the service documentation for the instrument through your Agilent Sales and Service office.

---

**WARNING**    **Danger of explosion if battery is incorrectly replaced. Replace only with the same or equivalent type recommended. Discard used batteries according to the manufacturer’s instructions.**

**Do not throw batteries away but collect as small chemical waste.**



DO NOT THROW BATTERIES AWAY BUT  
COLLECT AS SMALL CHEMICAL WASTE.

91790a

## Protecting Against Electrostatic Discharge

Electrostatic discharge (ESD) can damage or destroy electronic components.

### Test Equipment and ESD

To help reduce ESD damage that can occur while using test equipment:

- Before connecting any coaxial cable to a RF Preselector connector for the first time each day, momentarily short the center and outer conductors of the cable together.
- Personnel should be grounded with a 1 M $\Omega$  resistor-isolated wrist-strap before touching the center pin of any connector.
- Be sure that all instruments are properly earth-grounded to prevent build-up of static charge.

### Additional Information about ESD

For more information about ESD and how to prevent ESD damage, contact the Electrostatic Discharge Association (<http://www.esda.org>). The ESD standards developed by this agency are sanctioned by the American National Standards Institute (ANSI).

## Trademark Acknowledgements

Microsoft ® is a U.S. registered trademark of Microsoft Corporation.

Windows ® and MS Windows ® are U.S. registered trademarks of Microsoft Corporation.

Adobe Reader ® is a U.S. registered trademark of Adobe System Incorporated.

Java™ is a U.S. trademark of Sun Microsystems, Inc.

MATLAB ® is a U.S. registered trademark of Math Works, Inc.

Norton Ghost™ is a U.S. trademark of Symantec Corporation.

---

## 3 Front and Rear Panel Features

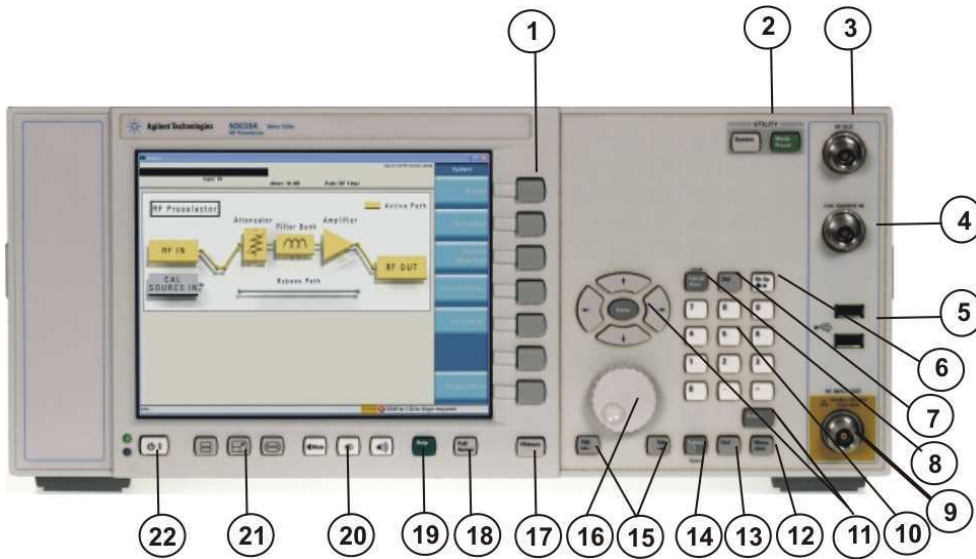
The following topics can be found in this chapter:

- “Front Panel Features” on page 30
- “Display Annotations” on page 33
- “Rear-Panel Features” on page 35
- “Front and Rear Panel Symbols” on page 36

## Front Panel Features

### Front-Panel Connectors and Keys

The RF Preselector implements softkeys, keys below the display, numeric keys, and navigation keys as described below.



Item		Description
#	Name	
1	Menu Keys	Key labels appear to the left of the menu keys to identify the current function of each key. The displayed functions are dependent on the currently selected Mode and Measurement, and are directly related to the most recent key press.
2	Utility Keys	<p><b>System</b></p> <p>This key accesses system related softkeys.</p> <p><b>Preset</b></p> <p>This key presets only the RF Preselector parameters, which include the attenuation, gain, signal path and filter band, to the factory preset state.</p>
3	RF Out	Supplies an RF signal to the PSA.
4	Cal Source In	Supplies a signal for filter alignment.
5	USB Connectors	Standard USB 2.0 ports, Type A. Connect to external peripherals such as a mouse, keyboard, DVD drive, or hard drive.
6	Back Space Key	It works as the Back key in Help and Internet Explorer windows.

Item		Description
#	Name	
7	Delete Key	Press this key to delete files, or to perform other deletion tasks.
8	Local/Cancel/ (Esc) Key	<p>If you are in remote operation, Local:</p> <ul style="list-style-type: none"> <li>• returns instrument control from remote back to local (the front panel).</li> <li>• turns the display on (if it was turned off for remote operation).</li> <li>• can be used to clear errors. (Press the key once to return to local control, and a second time to clear error message line.)</li> </ul> <p>If you have not already pressed the units or Enter key, Cancel exits the currently selected function without changing its value.</p> <p>Esc works the same as it does on a pc keyboard. It:</p> <ul style="list-style-type: none"> <li>• exits Windows dialogs</li> <li>• resets input overloads</li> <li>• clears errors</li> <li>• aborts printing</li> <li>• cancels operations.</li> </ul>
9	RF Input	Connector for inputting an external signal. Make sure that the total power of all signals at the RF Preselector input does <i>not</i> exceed +30 dBm (1 watt).
10	Numeric Keypad	Enters a specific numeric value for the current function.
11	Enter and Arrow Keys	<p>The Enter key terminates data entry when either no unit of measure is needed, or you want to use the default unit.</p> <p>The arrow keys:</p> <ul style="list-style-type: none"> <li>• Increment and decrement the value of the current measurement selection.</li> <li>• Navigate help topics.</li> <li>• Navigate, or make selections, within Windows dialogs.</li> </ul> <hr/> <p><b>NOTE</b>            The arrow keys cannot be used to move a mouse pointer around on the display.</p>
12	Menu/ (Alt) Key	Alt works the same as a pc keyboard. Use it to change control focus in Windows pull-down menus.
13	Ctrl Key	Ctrl works the same as a pc keyboard. Use it to navigate in Windows applications, or to select multiple items in lists.
14	Select / Space Key	Select is also the Space key and it has typical pc functionality. For example, in Windows dialogs, it selects files, checks and unchecks check boxes, and picks radio button choices. It opens a highlighted Help topic.
15	Tab Keys	Use these keys to move between fields in Windows dialogs.
16	Knob	Increments and decrements the value of the current active function.
17	Return Key	Exits the current menu and returns to the previous menu. Has typical pc functionality.
18	Full Screen Key	Pressing this key turns off the softkeys to maximize the graticule display area.
19	Help Key	Initiates a context-sensitive Help display for the current Mode. Once Help is accessed, pressing a front panel key brings up the help topic for that key function.

Front and Rear Panel Features  
**Front Panel Features**

Item		Description
#	Name	
20	Speaker Control Keys	Enables you to increase or decrease the speaker volume, or mute it in the Windows environment.
21	Window Control Keys	The message "Key Not Defined" will be shown on the message line when these two keys are pressed. However, the Switch Window key can be used to switch between the Help window navigation pane and the topic pane.
22	Power Standby On/Off	<p>Turns the RF Preselector on. A green light indicates power on. A yellow light indicates standby mode.</p> <hr/> <p><b>NOTE</b>      The front-panel switch is a standby switch, <i>not</i> a LINE switch (disconnecting device). The RF Preselector continues to draw power even when the line switch is in standby.</p> <p style="text-align: center;">The main power cord can be used as the system disconnecting device. It disconnects the mains circuits from the mains supply.</p> <hr/>

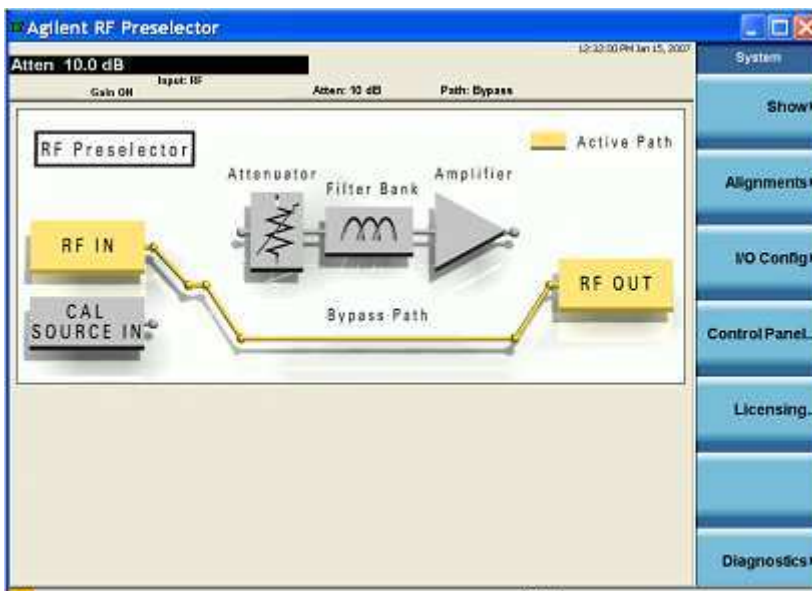


## Display Annotations

The user interface of the RF Preselector is used to display the hardware status, and some basic hardware control is available as part of the Service menu. As a compliant EMI measurement solution system, the user interface will be on the PSA.

## Screen Layout

The RF Preselector screen layout consists of a measurement bar, softkey panel, measurement display, and Message/Status bar.

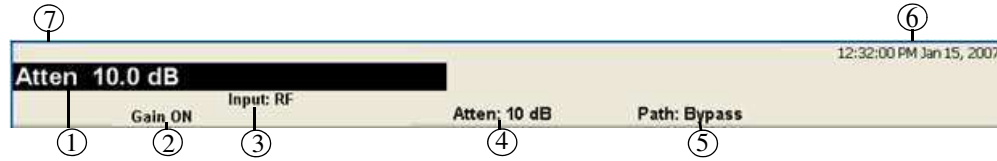


Front and Rear Panel Features  
**Display Annotations**

### Measurement Display

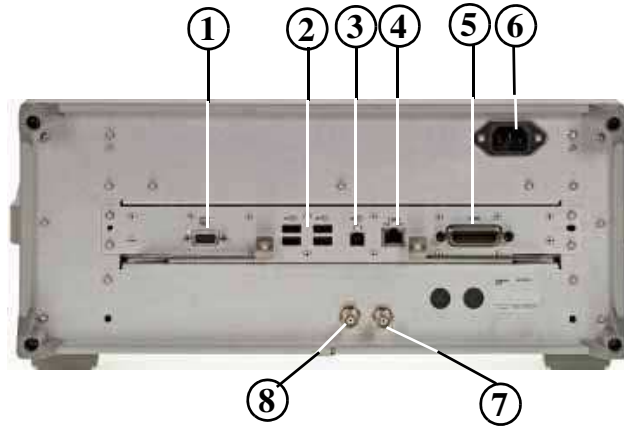
Since there are no measurements done in the RF Preselector, no data will be shown on the RF Preselector screen during a measurement. The RF Preselector shows the current hardware configuration diagram, whether in RF/ Source input or Bypass/Filter path mode.

#### Measurement Bar



Item		Description
#	Name	
1	Active Function	Used whenever an active function key is selected.
2	Gain	Shows "Gain On" when the internal gain is turned on.
3	Input	Indicates RF Preselector input, either "RF" or "SRC".
4	Attenuation	Shows the current attenuator setting in dB.
5	Signal Path	Shows the current signal path, either Bypass or RF Filter
6	Time and Date	Shows the current date and time.
7	Communication Mode	K = Indicates the instrument keyboard is disabled. See <a href="#">"Lock the Front Panel keys (Remote Command Only)"</a> on page 96 for more information. R = Remote L = Listen T = Talk.

## Rear-Panel Features



Item		Description
#	Name	
1	MONITOR	Allows connection of an external VGA monitor.
2	USB Connectors	Standard USB 2.0 ports, Type A. Connect to external peripherals such as a mouse, keyboard, printer, DVD drive, or hard drive.
3	USB Connector	USB 2.0 port, Type B. USB TMC (test and measurement class) connects to an external PC controller to control the instrument and for data transfers over a 480 Mbps link.
4	LAN	A TCP/IP Interface that is used for remote RF Preselector operation.
5	GPIB	A General Purpose Interface Bus (GPIB, IEEE 488.1) connection that can be used for remote RF Preselector operation.
6	Line power input	The AC power connection. See the product specifications for more details.
7	Pulse Trigger 2 Out	The output is used to drive the start of each sweep on the PSA.
8	External Trigger Out	The output is used to drive the sweep of each PSA sweep points using the PSA gated sweep.

## Front and Rear Panel Symbols



This symbol is used to indicate power ON (green LED).



This symbol is used to indicate power STANDBY mode (yellow LED).



This symbol indicates the input power required is AC



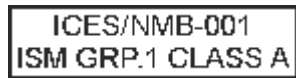
The instruction documentation symbol. The product is marked with this symbol when it is necessary for the user to refer to instructions in the documentation.



The CE mark is a registered trademark of the European Community



The C-Tick mark is a registered trademark of the Australian Spectrum Management Agency.



This is a marking of a product in compliance with the Canadian Interference-Causing Equipment Standard (ICES-001).

This is also a symbol of an Industrial Scientific and Medical Group 1 Class A product (CISPR 11, Clause 4).



The CSA mark is a registered trademark of the Canadian Standards Association International.



This symbol indicates separate collection for electrical and electronic equipment mandated under EU law as of August 13, 2005. All electric and electronic equipment are required to be separated from normal waste for disposal (Reference WEEE Directive 2002/96/EC).

**To return unwanted products, contact your local Agilent office, or see <http://www.agilent.com/environment/product/> for more information.**



Indicates the time period during which no hazardous or toxic substance elements are expected to leak or deteriorate during normal use. Forty years is the expected useful life of the product.

## Packaging



This symbol on all primary and secondary packaging indicates compliance to China standard GB 18455-2001.

Front and Rear Panel Features  
**Front and Rear Panel Symbols**

---

## 4 Instrument Configuration

This chapter describes the Microsoft® Windows XP® configuration and the settings used with the Agilent instrument software. It includes information about changing some of the system settings. It describes the Windows operating system configuration and the software installations that are present on the Hard Disk Drive when the instrument leaves the factory.

The front panel of the RF Preselector has been designed with the keys needed to navigate windows. It is possible to use the front panel for changing Windows XP configuration items, but it is much easier to perform these tasks with a USB mouse and external keyboard.

The following topics can be found in this chapter:

- [“Agilent Software Installed” on page 40](#)
- [“Customer Installation of Software” on page 41](#)
- [“User Accounts” on page 42](#)
- [“Windows Configuration” on page 44](#)
- [“Configuring Printers” on page 47](#)
- [“Configuring LAN” on page 48](#)
- [“Windows Security” on page 50](#)
- [“System Maintenance” on page 54](#)
- [“USB Connections” on page 55](#)
- [“Hard Drive Partitioning and Use” on page 56](#)
- [“Hard Drive Recovery Process” on page 57](#)

## **Agilent Software Installed**

The N9090A Agilent RF Preselector Application software is installed in the N9039A RF Preselector platform.



---

## Customer Installation of Software

### 3rd Party Software Verified by Agilent

Agilent has verified that the following programs are compatible with the instrument applications:

- Symantec AntiVirus™ Corporate Edition version 9.0.0.338
- MathWorks MATLAB

### Installation of Other 3rd Party Software

The N9039A is an Open Windows environment, so you can install non-approved software on the instrument. However, installation of non-approved software may affect instrument performance. Agilent does not warrant the performance of the N9039A with non-approved software installed.

---

**NOTE** Before installing any additional programs on the instrument, you should exit the RF Preselector application.

Also, you must not remove any applications or programs that are installed on the instrument when it is shipped from the factory.

---

If you install programs other than those which Agilent has tested, it could cause problems with the instrument's applications. If this happens, you should try uninstalling the program that has caused the problem, or try changing the program's configuration. If this does not correct the problem, you may have to use the Agilent Recovery system to reinstall the instrument's system software.

## User Accounts

### Administrator Login

The Administrator account ships from the factory with the password “agilent4u”. Using the Administrator account you can perform the following operations:

- Install software
- Configure network and printer access
- Access all files on the instrument
- Add or change user accounts and passwords
- Change Windows settings
- Run any application

### User Login

The default user account that ships from the factory is “Instrument” with the password “measure4u”. This user is a member of the Power Users group. Using the Instrument account you can perform the following operations:

- Install software
- Configure network and printer access
- Access files on the instrument that are accessible to the Power Users group
- Run applications that are accessible to the Power Users group

### AgilentOnly user account

The instrument contains a user account called “AgilentOnly” that can be used by Agilent’s customer support in the event that the Administrator password was changed and has since been lost/forgotten. You must not remove or modify the AgilentOnly account.

### Agilent Service user accounts

User accounts are defined for Agilent’s use if it is necessary to service the instrument.

## Customer creation of accounts

You can create additional user accounts and decide on the level of security granted to any new user accounts created. For example, the level of security can be assigned as administrator, power user, user, backup operators. User names are not case sensitive but passwords are case sensitive.

---

**NOTE** For the RF Preselector software to operate the user account executing the software must be assigned Administrator or Power User privileges. Otherwise, the RF Preselector software will not operate correctly.

---

It is Agilent's expectation that each user's My Documents folder is mapped to the D: drive. This is to avoid overwriting the user's data in the event the Agilent Recovery must be performed. Also, this facilitates convenient backup by copying the contents of the D: drive to external media. All users accounts created by the factory already have My Documents mapped to the D: drive. Please map all new users My Documents folders to the D: drive.

## Windows Configuration





The Windows settings have been optimized for the best measurement performance. Any modifications to these settings may degrade instrument performance and measurement speed. In general, most Windows System settings (typically set through the Windows Control Panel) should not be modified. Those that can be safely modified are listed below.




**CAUTION** To recover from problems caused by changing Windows systems settings, you may have to reinstall the Windows system and instrument application using the Agilent Recovery process.

### Settings That Can Be Changed

You may change the following Windows settings or administrative tasks (available from the Windows Control Panel) to select your personal preferences.





**NOTE** Before changing any Windows System settings, exit the instrument application.


You May Use This Feature	To Do This . . .
 Automatic Updates	Configure Microsoft Automatic Updates.
 Security Center	Install and configure an Anti Virus program.
 User Accounts	Setup new Instrument user accounts. <b>CAUTION</b> Do not delete or modify the "Agilent-Only" user account
 Network Connections	Add the Instrument to a network.

You May Use This Feature	To Do This . . .
 Printers and Faxes	Install and configure a printer.
 Date and Time	Set the time and date.
 System	Modify System Properties, Advanced Tab settings of Performance, Adjust for Best Performance. Leave all other settings unchanged.

### Settings That Must Not Be Changed

Avoid changing any settings in this section. Changes to the following settings may degrade instrument performance, screen displays, and measurement speed.

Do NOT Use This Feature	To Do This . . .
 Power Options	Do not change Power Options. (Power Scheme, Power Button, Hibernate)
 System	Do not modify System Properties, Hardware Tab settings (Device Manager, Drivers). Do not modify System Properties, Advanced Tab settings (Performance, User Profiles, Startup and Recovery, Environment Variables, Error Reporting)
 Fonts	Do not remove installed Fonts.
 Display	Do not change the following Display Settings: <ul style="list-style-type: none"> <li>• Screen Saver settings</li> <li>• The screen resolution, 1024 x 768</li> <li>• DPI setting from Normal size (96 DPI)</li> </ul>

Do NOT Use This Feature	To Do This . . .
 User Accounts	Do not delete or modify the "AgilentOnly" user account.

In addition, **DO NOT**:

- Add, delete, or modify hard-disk drive partitions.
- Delete or modify Agilent registry entries.
- Change the contents of any directories containing the name "Agilent"
- Stop these services:
  - The MSSQL\$CDF service or uninstall the "Microsoft SQL Server Desktop Engine"
  - The IIS server or tamper with any virtual directories (or their contents) that came configured with the instrument.
- Uninstall these libraries, interfaces, or programs:
  - The Agilent I/O Libraries
  - The .NET Framework or any Hotfixes or Service Packs for the .NET Framework
  - The "Microsoft Visual J# .NET Redistributable Package 1.1"
  - Programs that begin with "Agilent"
  - The Adobe Acrobat Reader
- Modify
  - The Agilent I/O Library "GPIB27", "GPIB28" interfaces shown as configured Instrument I/O in the Agilent Connection Expert or I/O Config.

---

## Configuring Printers

Printers are configured using the Microsoft Windows Control Panel. It is easily accessed from the Windows Start menu or from under the front panel **System** key. This setup process is most easily done using a USB Mouse and an External Keyboard. If you don't have a mouse it can be done using front panel keys, and you might want to reference the section on [Table 2-1., "Using the Interactive Help System Without a Mouse,"](#) on page 24.

When setting up a new printer, you may need to load the printer driver (unless you are using a network printer that your IT department has set up to include the driver). The manufacturer of the printer supplies the driver software and process. That may require that you attach an external USB disk drive. An alternative is to connect the instrument to the LAN and download the driver from the printer manufacturer's internet site.

---

## Configuring LAN

### Hostname

The Computer Name, or hostname, is pre-configured from the factory. It must be a unique name such that it will not conflict with other equipment on your LAN. The pre-configured Computer Name is A-N9039A-xxxxx, where xxxxx is the last 5 digits of the instrument's serial number.

To change the Computer Name consult the Microsoft Windows XP Help and Support Center.

### IP Address & Gateway

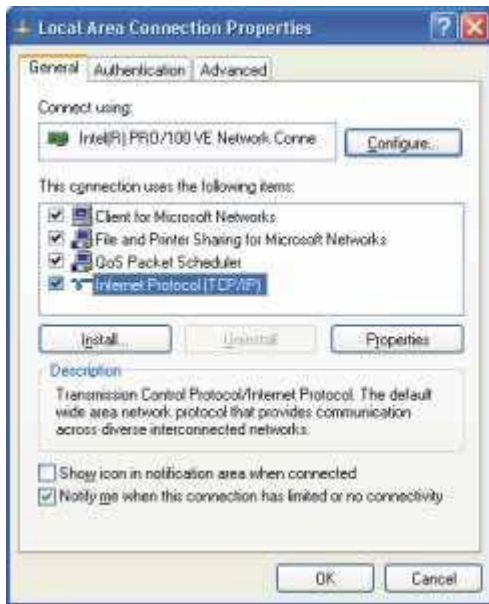
The instrument is pre-configured to obtain an IP Address using DHCP. If you are not connected to a DHCP server, the instrument will auto generate an IP address. The IP Address and Gateway can be changed using the following instructions:

1. On WindowsXP in the RF Preselector, log on as “administrator” using the password “agilent4u”.
2. Go to **Start, Control Panel, Network and Internet Connections, Network Connections**, right-click on **Local Area Connection**, and select **Properties**.

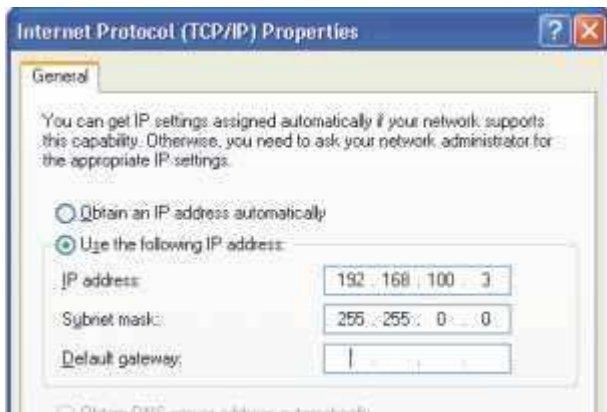




3. In the Local Area Connection Properties window, scroll down the items list and select **Internet Protocol (TCP/IP), Properties**



4. In the Internet Protocol (TCP/IP) Properties window, select **Use the following IP address** and enter the desired IP address, Subnet mask, or Default gateway.



## Windows Security

Microsoft recommends the following three steps to ensure the instrument's Windows XP operating system is protected:

1. Use an internet firewall.
2. Get the latest critical Windows updates.
3. Use up-to-date antivirus software.

To check the status or make changes in the security settings for you instrument, open the Windows Security Center, click **Start**, **Control Panel**, and then click **Security Center**.



**NOTE** The window may look slightly different on your instrument.

## Windows Firewall

The instrument is shipped with the Windows Firewall enabled.



**NOTE** The window may look slightly different on your instrument.

Windows Firewall **Exceptions** for programs and ports have been added to allow proper operation of the instrument over a network. Modifying these settings may cause the instrument to not operate properly.

## Automatic Updates

The default instrument setting is to automatically check for critical Windows Updates, notify you, download the updates and install them, if the instrument has internet access.

You can change the configuration of the Microsoft Automatic Updates. You can choose not to have automatic updates. Then you can manually update Windows by accessing Internet Explorer and from the Tools menu select Windows Update.



**NOTE** Be aware that downloading and installing Windows Updates can be network and CPU usage intensive (impacting the instrument performance) and some Windows Updates will automatically reboot the instrument. It is recommended that Windows Updates be performed when the instrument is not in normal use.

## Virus Protection

There is no antivirus software included with your instrument. Antivirus application software has been tested to be compatible with the instrument. See the section on “3rd Party Software Verified by Agilent” on page 41 in the Instrument Configuration chapter for Anti-Virus software that has been tested by Agilent.

---

**NOTE** Having antivirus software installed may have a slight impact on the instrument performance.

---



## Spyware Protection

There is no anti-spyware software installed on the instrument. But as long as you don't use the instrument for a lot of internet browsing, this should not be a problem. However, having spyware in the instrument could have an impact on the instrument performance.

---

## System Maintenance

### Backup

It is recommended that you have a regular backup strategy. Your IT department may already have a backup strategy in place which is suitable for the instrument and its data. Using the Agilent Recovery system in conjunction with a regular backup strategy should allow full recovery of the instrument data.

Windows XP has a Backup utility that you can use to archive files and folders in case of a hard disk drive failure. See the Microsoft Windows XP Help and Support Center for more information on this utility. You can also use third party backup utilities. However, you must ensure that this third party software is compatible with the instrument's system software. See [Customer Installation of Software](#) for more information.

When performing backups, we recommend that you backup the data to an external storage device connected to the network or one of the instrument's USB connectors. Also, you should perform backups at times when the instrument is not being used for normal operations as it may impact the instrument's overall performance.

### System Restore

Windows XP contains capability to restore the system to a previous point in time. System Restore is enabled with default settings as provided by Microsoft. However, System Restore is not 100% successful. Therefore it is not the recommended method to backup the instrument. System Restore has not been tested to verify successful restoring.

### Disk Defragmenting

Over time the instrument's hard disk will become fragmented. Windows XP has a Disk Defragmenter utility that you can use to defragment the hard disk. See the Microsoft Windows XP Help and Support Center for more information on this utility.

---

**NOTE** Running Disk Defragmenter should be performed when the measurement application is not running. Measurement throughput will be significantly impacted while disk defragmentation is in process.

---

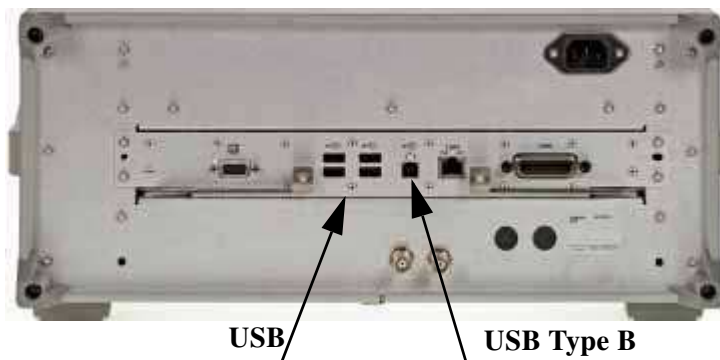
## USB Connections

All of the RF Preselector USB ports meet the USB 2.0 specification. The two USB ports on the front panel (see graphic below) and four of the USB ports on the rear panel are USB Series "A" ports. These are ports to which you can connect USB mass storage devices and printers. The instrument USB Host support includes the standard Microsoft Windows XP USB class drivers for human interface, mass storage, printing, and scanning/imaging devices. A complete and up to date list of the Windows XP USB class driver support is available on the Microsoft website.

[http://www.microsoft.com/whdc/system/bus/usb/USBFAQ\\_intro.mspx](http://www.microsoft.com/whdc/system/bus/usb/USBFAQ_intro.mspx)



The square USB port (see graphic below) on the rear panel is a USB Series "B" port and is used for controlling the instrument over USB. The instrument USB Device driver included in the instrument software supports the test and measurement industry standard USBTMC-USB488 device class.



In addition, the Agilent IO Libraries CD that was included with your instrument contains USB Host drivers that allow control of other instruments connected to the USB bus.

Agilent Technologies does not support or warrant correct instrument operation if additional USB drivers from third parties are installed in the instrument. It is possible that additional drivers could break the normal USB operation. If USB operation is broken, recovery would require reinstalling the instrument application using the hard drive recovery process.

## Hard Drive Partitioning and Use

The drive is partitioned into 3 sections: C:, D: and E:

- The **C: partition** contains the Windows XP operating system and software installed by Agilent. This is an Open System which means you can install additional software, and these should be installed on the C: drive. However, only a limited set of software applications are tested for use with the Agilent measurement software. The installation and/or use of other software is not warranted, and could interfere with the operation of the measurement software. If instrument repair is ever needed, the Agilent version of the C: drive is the only part of the instrument software that is restored by the Agilent Recovery process. You will have to reload any other software that you have added in the instrument.
- The **D: partition** is reserved for data storage. The User Accounts that are configured by Agilent have their My Documents folder mapped to the D: drive. This is for the convenience of backing-up the measurement data. You should always back-up the data on the D: drive to an external device. This allows you to restore the data if you ever need to replace the hard drive.
- The **E: partition** is reserved for Agilent's use. The primary use of the E: drive is for housing the Calibration and Alignment data. Do not change or overwrite the files on this drive. This could cause your instrument to not meet specifications, or even to stop functioning correctly. Do not use this drive for data storage. It is also recommended that you back up the contents of this drive to an external device.



---

## Hard Drive Recovery Process

The Agilent Recovery System can be used to repair errors on the instrument's C: drive partition, or to restore the original factory configuration of the system software. The Agilent Recovery System is stored in a separate hidden hard disk drive partition.

Repairing errors on the hard disk drive may result in loss of data or files. If you need more information about the Windows "chkdsk" error repair process, see the chkdsk documentation in the Microsoft Windows XP Help and Support Center.

Restoring the original factory system software does not restore any of the following items:

- Windows system configurations that were made after the instrument was shipped from the factory. For example, Windows and Service Pack updates, user accounts, and windows configuration settings. After an Agilent Recovery, these configurations will have to be redone.
- Additional software that was installed after the instrument was shipped from the factory. After an Agilent Recovery, that software will need to be re-installed.
- Any data or programs saved on the D: or E: drives.
- Any upgrades that were made to the Agilent measurement application software.

---

**NOTE** It is recommended that you use a regular back up strategy. Your IT department may already have a back up strategy in place which is suitable for the instrument and its data. See the [System Maintenance](#) section. Using the Agilent Recovery System in conjunction with a regular back up strategy should allow you to fully recover the instrument software and data.

---

It is recommended that routine backups of the instrument information be performed to keep current archives of the instrument information. This will allow a full recovery of the instrument information after the instrument recovery system operations are performed. See the "Backing Up the Instrument Information" section for more details.

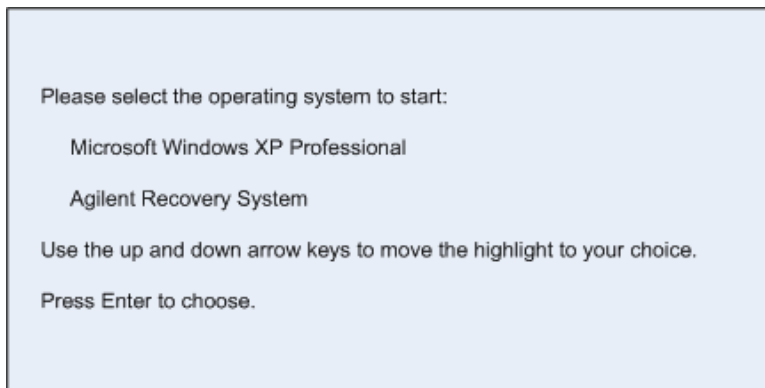
Instrument Configuration  
Hard Drive Recovery Process

Using the Instrument Recovery System:

1. Make sure the instrument is turned off.
2. Turn on the instrument.
3. After the "Agilent Technologies" screen is displayed,



the following screen contents will be displayed for 5 seconds.



4. Press the down arrow key to move the highlight to "Agilent Recovery System", press the **Enter** key.
5. When the Agilent Recovery System has booted, follow the on-screen instructions to perform the desired recovery operations.
6. After exiting the Agilent Recovery System, the instrument will reboot. If the original factory instrument system has been restored, the instrument will re-execute the [Turning on the RF Preselector the First Time](#) process. See [page 20](#).
7. Additional recovery steps may be required to fully recover the system to a more current working state. This could involve restoring your own backups of the instrument configuration, including re-installing applications, data, and performing system customizations.

## Configuring Recovery Prompt Timing

You can configure the time at which the instrument power-up process waits for the selection of the recovery process by performing the following steps:

1. Get to My Computer, Properties
2. Select “Advanced” tab
3. In the “Startup and Recovery” section, select “Settings”
4. Under the “System Startup” section, you can either uncheck “Time to display list of operating systems:” or change the seconds to delay for it.

---

**NOTE** You must be logged in as an administrator in order to change these settings. See [“User Accounts” on page 42](#) for more information.

---

Instrument Configuration  
**Hard Drive Recovery Process**

---

## 5 Using Microsoft Windows XP

---

**NOTE** The capabilities described in this section are Microsoft Windows XP features. The discussion provided here gives some guidelines for using the capabilities with the instrument. Refer to the Windows XP help documentation for more information. Your version of Windows may not match these instructions exactly.

You need an external keyboard and mouse to fully use these features.

---

The following topics can be found in this chapter:

- [“Remote Desktop: Using the N9039A Remotely” on page 62](#)
- [“Embedded Web Server: Using the N9039A Remotely” on page 69](#)
- [“Capturing/Printing Displays and Windows” on page 73](#)
- [“Windows Shortcuts and Miscellaneous Tasks” on page 74](#)

---

## Remote Desktop: Using the N9039A Remotely

Windows Remote Desktop is recommended for remote control of the Instrument. It offers fully-interactive control, that is almost identical to direct face-to-face control of the instrument. You can also remotely control the instrument using the Embedded Web Server interface. The Embedded Web Server functionality provides a communications method that does not require login to the Instrument. However, due to its slower response time, it is only recommended for setup and data exchanges that do not involve instrument control.

---

**NOTE** The Remote Desktop functionality is a Microsoft Windows XP capability. The following discussion provides some guidelines for using this capability with the instrument. You will have to refer to the Windows XP help documentation for more information. As Windows evolves, these instructions may no longer be exact.

---

You need an external keyboard and mouse to fully use this functionality.

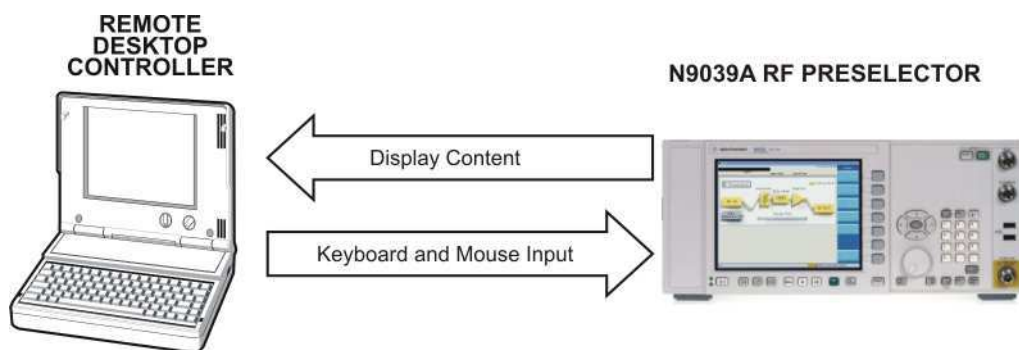
### Overview of Remote Desktop Operation

Using the Remote Desktop functionality of the Instrument allows you to control and interact with the Instrument from a remote computer, as though you were sitting in front of the Instrument.

When you have configured the Instrument for remote connectivity, and configured a separate computer to act as a Remote Desktop Host, you can send commands to the Instrument from the Remote Computer, and you can see the Instrument Display on the screen of the Remote Computer.

This Section provides full details of how to set up the Instrument for remote connectivity, and also how to set up a computer running any 32-bit version of Microsoft Windows as a Remote Desktop Host.

**Figure 5-1. Basic Setup for Remote Desktop Operation**



### Setting Up Remote Desktop Operation

#### Setting Up the Instrument

Before the Instrument may be controlled via a Remote Desktop Connection, it must be set up to allow connection from a remote computer.

---

**NOTE** To perform this operation successfully, you must have Administrator level access to the Instrument.

---

To perform setup, do the following:

1. Open the Windows Control Panel, by *either*:
  - from the Instrument Application, pressing **System, Control Panel...**, *or*,
  - from the Windows Desktop, clicking **Start, Control Panel**.
2. If the Control Panel appears with “Category View”, click **Performance and Maintenance**, then click **System**. If the Control Panel appears with “Classic View”, *double-click* **System**.
3. Select the Remote Tab of the System dialog.
4. A Warning Message appears, informing you that it may be necessary to configure your internet connection sharing or personal firewall to permit Remote Desktop connections. The details of such configuration are beyond the scope of this document.
5. In the “Remote Desktop” section of the dialog, check the “Allow users to connect remotely to this computer” checkbox.
6. Click the “Select Remote Users...” button, then follow the on screen instructions to add users. All users who have Administrative level access are listed as already having permission.

### Setting Up the Remote Computer

The procedure depends on whether the Remote Computer to be set up is running Windows XP, or another version of Microsoft Windows.

**Remote Computer running Windows XP** Windows XP includes the Remote Desktop Connectivity Client software, so no additional setup is required.

**Remote Computer running another Version of Windows** You can use any *32-bit* version of Windows (Windows 95, 98, ME, NT4, or 2000) to install and run the Client software for Remote Desktop Connectivity. However, you need to have available a Windows XP installation CD-ROM, because that contains the Client software.

---

**NOTE** The following instructions relate to software provided by Microsoft Corporation. Agilent offers no warranty regarding the operation of such software. The procedure described here may be changed by Microsoft at some future time.

---

To install the Client software, do the following:

1. When the Welcome Screen appears, select **Perform additional tasks**.
2. From the “What do you want to do?” screen, select **Set up Remote Desktop Connection**.
3. The “Remote Desktop Connection InstallShield Wizard” appears. Click **Next** to begin the installation, and follow the on screen instructions provided by the Wizard.
4. Once the Remote Desktop Client Software is installed, you can access it via the Windows Start menu, under **All Programs > Accessories > Communications > Remote Desktop Connection**.

## Running a Remote Desktop Session

### Initializing a Remote Desktop Session

---

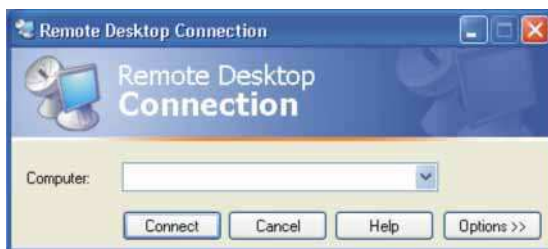
**NOTE** In order to initialize a Remote Desktop Session, you need to know the “Computer Name” of the Instrument. This information can be shown on the Instrument display by following the procedure in the Section [“How To Locate the Computer Name of the Instrument”](#) on page 68.

---

After setting up both the Instrument and the Remote Computer for Remote Desktop Connectivity, as described in the Section [“Setting Up Remote Desktop Operation”](#) on page 62, you are ready to start a Remote Desktop session.

To start a Remote Desktop session from the remote computer:

1. Click Start > All Programs > Accessories > Communications > Remote Desktop Connection.
2. A Remote Desktop Connection dialog appears.



In the box titled Computer, enter the Computer Name of the Instrument. (For instructions on how to obtain this, see the Section [“How To Locate the Computer Name of the Instrument”](#) on page 68.)

3. Click Connect.
4. Log in to the Instrument. In the login dialog that appears, enter the login account name and password. The default account name is “Instrument” and the default password is “measure4u,” but note that these parameters may be changed by Instrument users.

---

**NOTE** Only the current User or an Administrator can remotely log into the instrument. To see who the current user of the instrument is, press **Ctrl+Esc** on the instrument until you can view the current user name on the Start menu. If no one is currently logged into the instrument, any valid instrument user can remotely log in.

---

5. The Instrument Display appears on the screen of the Remote Computer. Because the Instrument Front Panel keys are not available when using the Instrument remotely, three alternative methods are available to mimic the functions of the Front Panel keys, as detailed in the Sections, [“Popup Menus for Remote Desktop Operation”](#) on page 67, [“The Virtual Front Panel”](#) on page 67.



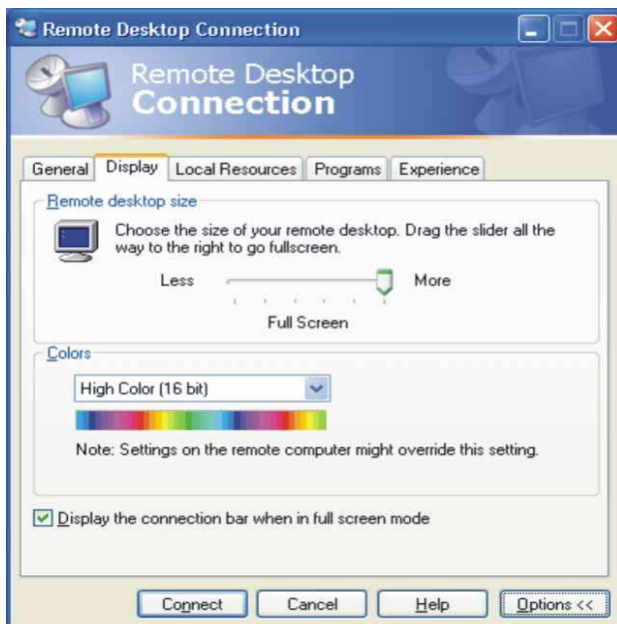
## Setting Remote Desktop Options

Clicking the Options button in the Remote Desktop Connection dialog displays the Options dialog:



The Options dialog has several tabs. Generally, the default settings are correct. However, there are some restrictions on particular settings under certain tabs, as listed below.

- Under the **General** tab, ensure that the Computer Name, User name and Domain name are correctly set. You may choose to enter the password and save it for future sessions, by checking the **Save my password** box.
- The information displayed under the **Display** tab is as shown below:



- Under Remote desktop size, you may select the size of the window in which the Instrument display will appear. Do *not* select any size smaller than 1024 x 768 pixels. Selecting a remote desktop size smaller than 1024 x 768 results in the Instrument display not being fully visible. In such circumstances, scroll bars do not appear, so portions of the display are not accessible.
- Under Colors, you may select any setting that uses 15 bits or more. Selecting a color setting that uses less than 15 bits results in dithering and incorrect color rendition of the remote desktop window.
- The information displayed under the Experience tab is as shown below:



To optimize the performance of the Remote Desktop session, choose the appropriate connection format from the drop-down listbox.

### Ending a Remote Desktop Session

There are two ways to disconnect the remote computer from the Instrument, ending the Remote Desktop session.

1. If the remote desktop window is full-screen, click the X at the right of the connection bar that appears at the top center of the window. If the remote desktop window is not full-screen, click the red X box at the right of the window's title bar. In both cases, a dialog appears, asking you to confirm that you wish to disconnect. Click OK to disconnect.
2. Move the cursor to the bottom left of the remote desktop window, to cause the taskbar to appear. Click Start, then click the red Disconnect button at the lower right of the Start menu (this corresponds to the Shut Down button in a non-remote Windows session). A dialog appears, asking you to confirm that you wish to disconnect. Click Disconnect to disconnect.

### Popup Menus for Remote Desktop Operation

Right-clicking the mouse over the application display window pops up a menu hierarchy, which may be used as alternatives to the Front Panel keys.

The function of each selection in the popup menu is generally identical to that of the corresponding Front Panel key. There are certain additional items, as listed below:

- **Exit.** Selecting this item closes the Application software.
- **Utility>Virtual Front Panel.** Selecting this item opens the Virtual Front Panel window, as described in the Section [“The Virtual Front Panel”](#) on page 67.

---

**NOTE** The popup menus are also available when using the Instrument directly, provided that a mouse or other pointing device is attached to it.

---

### The Virtual Front Panel

The Virtual Front Panel is a software equivalent of the Front Panel key set, which provides a further alternate method for Instrument control. It may be displayed in a separate window on the Instrument (or Remote Desktop) display.

---

**NOTE** The Virtual Front Panel is also available when using the Instrument directly, provided that a mouse or other pointing device is attached to it.

---

To display the Virtual Front Panel, right-click the mouse over the application display window, then select **Utility>Virtual Front Panel** from the popup menu. :

Clicking a button in the Virtual Front Panel mimics the operation of the corresponding Instrument Front Panel key. The buttons at the left of the panel, named **Key 1** through **Key 7**, mimic the operation of the respective softkeys. The **Rpg Up** and **Rpg Down** keys mimic the operation of the Thumbwheel.

## How To Locate the Computer Name of the Instrument

To connect a remote computer to the Instrument, you need to know its “Computer Name.” The Computer Name can be displayed as follows:

*From the Agilent Application:*

1. On the Instrument Front Panel, press **System, Show, System**.
2. A page listing various parameters appears. The Instrument’s Computer Name is shown in the list alongside the title “Computer Name”.

*From the Windows Desktop (with a mouse attached to the Instrument):*

1. Click **Start, Control Panel**.
2. If the Control Panel window appears in Category View, click **Performance and Maintenance**, then **System**, to display the System Properties dialog. If the Control Panel appears in Classic View, double-click **System** to display the System Properties dialog.
3. Click on the **Computer Name** tab of the System Properties dialog.
4. To close the System Properties dialog, click **Cancel**.

*From the Windows Desktop (without a mouse attached to the Instrument):*

1. Press **Ctrl+Esc** to display the Windows Start menu, then use the **Up Arrow** or **Down Arrow** keys to select the **Control Panel** item. Press **Enter** to open the Control Panel dialog.
2. If the Control Panel window appears in Category View, press **Tab** to select **Performance and Maintenance**, then press **Tab** to select **System**. The System Properties dialog is displayed. If the Control Panel appears in Classic View, press **Tab** to select **System**, then press **Enter**, to display the System Properties dialog.
3. Press **Ctrl+Tab** until the **Computer Name** tab is selected. The Computer Name is displayed under “Full computer name.”
4. To close the System Properties dialog, press **Tab** to select the **Cancel** button, then press **Enter**.
5. To close the Control Panel dialog, press **Alt+Select** to open the drop-down **File** menu, then press the **Down Arrow** until the **Close** menu item is selected. Press **Enter** to close the Control Panel dialog.

## Embedded Web Server: Using the N9039A Remotely

The instrument can be controlled using either the Embedded Web Server or Windows Remote Desktop. The Embedded Web Server is a good solution when you do not want to log into the instrument's user account. This allows you to view the display or control the instrument, without logging the current user off. Windows Remote Desktop must be used when the remote computer keyboard is needed as an input device (such as for editing filenames, or setting the title.) Also, Windows Remote Desktop generally has a faster response time.

### Accessing the Instrument via the Internet: Overview

It is possible to access and control the Instrument through the Internet and World Wide Web, or a local internet, using the built-in Embedded Server functionality. This section provides details of how to use this functionality.

The Instrument may also be accessed and controlled using the Windows Remote Desktop functionality (see the section [“Remote Desktop: Using the N9039A Remotely”](#) on page 62, for details).

### How To Access the Instrument from the Internet

---

**NOTE** To gain access to the Instrument from the LAN, you need to know its hostname (or IP Address). For details of how to locate this information through the Instrument Display, see [“How To Locate the Computer Name of the Instrument”](#) on page 68.

---

To access the Instrument from the Internet, do the following:  
(This is only fully supported when using Internet Explorer.)

1. From a web browser (for example, Internet Explorer), enter a URL corresponding to the Instrument hostname *or* IP Address.
2. Upon successful connection to the Instrument web server, the welcome page is displayed, which provides basic information about the Instrument's internet settings.
3. At the left hand side of the welcome page are a set of tabs that provide access to configuration information for the Instrument, plus the ability to control it via the web interface. For more information about the functionality available under each tab, see the following sections:
  - [“View & Modify Configuration Tab”](#) on page 70
  - [“Web Control RF Preselector Tab”](#) on page 70
  - [“SCPI Telnet Tab”](#) on page 71
  - [“Help Tab”](#) on page 72

### View & Modify Configuration Tab

Click on the **View & Modify Configuration** tab to display the Instrument's currently-assigned IP address, plus other TCP/IP parameters:

To modify the current configuration, do the following:

1. Click on either of the **Modify Configuration** buttons on the Current Configuration web page.
2. A password entry dialog appears.:
3. By default, this password is set at the factory as "agilent". You may subsequently change the password. (Press **System, Config I/O, Reset Web Password** on the instrument front panel to change the password.)
4. When the correct password has been entered, the Modify Configuration web page appears.
5. Enter new settings as required, then click **Apply** to cause the new settings to take effect. The button **Undo Changes** may be used to revert all settings to their previous values, provided this button is clicked before clicking **Apply**.

---

**NOTE** Tool tips are available for each of the configuration buttons on this page.

---

### Web Control RF Preselector Tab

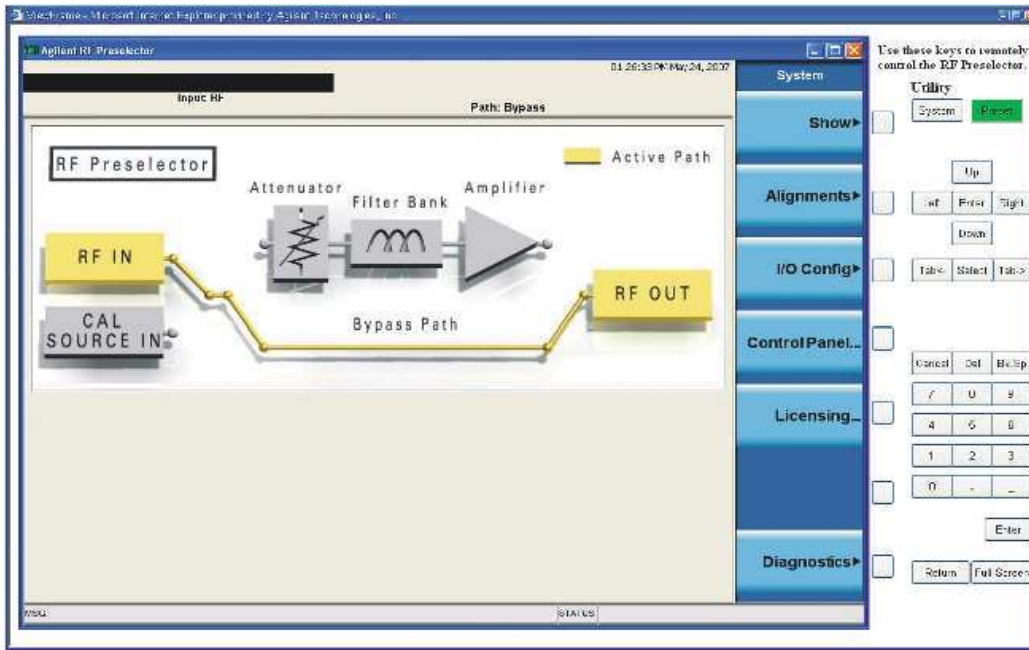
Selecting this tab lets you view, control and interact with the Instrument through the web server.

1. Click on the Web Control RF Preselector tab.
2. A password entry dialog appears, as shown:



3. By default, this password is set at the factory as "agilent". Note, however, that the user may subsequently change the password. (Press **System, Config I/O, Reset Web Password** on the instrument front panel, to change the password.)

4. When the correct password has been entered, the instrument control web page is displayed.



---

**NOTE** To view the instrument display using the web server, the instrument application must be running.

---

The web page shows the instrument application screen and a virtual keyboard that can be used to control the instrument. You can use the on-screen buttons to perform operations as though you were sitting in front of the instrument itself, and using the physical front panel.

### SCPI Telnet Tab

Selecting the SCPI Telnet tab opens a Telnet session between the Instrument and the client computer. The Instrument TCP/IP port used for SCPI access is 5023.

---

**NOTE** To run a SCPI Telnet session, the Instrument Application must be running.

---

1. A password entry dialog appears.
2. By default, this password is set at the factory as “agilent”. Note, however, that the user may subsequently change the password. (Press **System**, **Config I/O**, **Reset Web Password** on the instrument front panel, to change the password.)
3. When the correct password has been entered, the connection window appears.
4. Click on the SCPI Telnet Session link, and the telnet command line interface appears.

SCPI commands and queries may be entered through the command line interface. To exit the Telnet session, press **Ctrl+]** on the client computer keyboard.

## **Help Tab**

Select the Help tab to display basic help information about each of the other tabs, plus performance tips.



---

## Capturing/Printing Displays and Windows

---

**NOTE** This capture/print functionality is a Microsoft Windows XP capability. The following discussion provides some guidelines for using this capability with the instrument. Refer to the Windows XP help documentation for more information.

---

You need an external keyboard and mouse to use this feature.

### **Save the Desktop:**

1. Capture the entire desktop by pressing the external keyboard **Print Screen** key. This saves the desktop on the Windows clipboard.
2. Open a graphics software program like Microsoft Paint.
3. Paste the clipboard contents into the program. (**Ctrl + v**)
4. Save the image in a file.

### **Save the Current Active Window:**

1. Click on the window you want to capture (activate it).
2. Capture the window by pressing the keys on the external keyboard **Alt + Print Screen** key. This saves the active window on the Windows clipboard.
3. Open a graphics software program like Microsoft Paint.
4. Paste the clipboard contents into the program. (**Ctrl + v**)
5. Save the image in a file.

## Windows Shortcuts and Miscellaneous Tasks

This section provides a list of windows shortcuts (key combinations) that are useful when you operate the instrument without an attached mouse and keyboard. Although these shortcuts are available in *any* Windows XP system, they are not commonly used when a mouse and keyboard are attached.

This section also includes details of certain windows tasks that may be required from time to time when using or configuring the Instrument.

### Windows Shortcuts (Key Combinations)

You can use the following combinations of front panel keys to perform basic windows tasks when using the instrument without an attached mouse and keyboard.

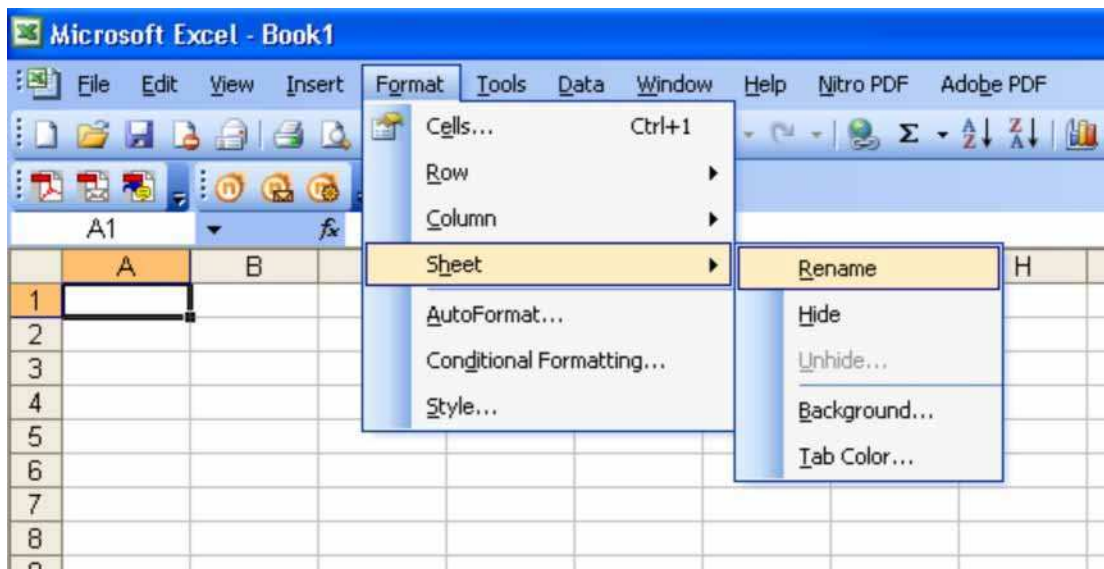
**Table 5-1. Windows Shortcut Key Combinations**

<b>To do the following:</b>	<b>Press:</b>
Display the Windows Start Menu	<b>Ctrl+Esc</b>
Cycle through all open applications	<b>Alt+Tab</b>
Select the first menu of a menu bar	<b>Alt</b>
Move through menu headings	<b>Left Arrow, Right Arrow</b>
Open (drop down) a menu	<b>Down Arrow</b>
Move through items in an expanded menu	<b>Up Arrow, Down Arrow</b>
Close the current menu selection	<b>Esc</b>
Cancel the current menu bar selection	<b>Alt</b>
Open an application's control menu (usually the left-most menu on the menu bar, starting with <b>F</b> ile)	<b>Alt+Select</b>
In a dialog: move between tabs	<b>Ctrl+Tab</b>
In a dialog: move forward through dialog box items	<b>Tab</b>
In a dialog: move backward through dialog box items	<b>Shift+Tab</b>
In a dialog: open a list box	<b>Alt+Down Arrow</b>
In a dialog list box or check box: select or deselect items	<b>Select</b>
In a dialog list box or check box: select or deselect one item at a time	<b>Shift+Up Arrow, Shift+Down Arrow</b>
In <b>My Computer</b> , expand a selected folder	<b>Enter</b>
In <b>My Computer</b> , open a folder one level up from the current folder	<b>Bk Sp</b>

### Example: Navigating an Application Menu without a Mouse or Keyboard

This example uses Microsoft Excel, but you can use a similar sequence of operations to select and execute *any* menu item of *any* application.

To select and execute the item Sheet > Rename option from the Format menu in the menu bar shown below



perform the following operations:

1. With the focus in the appropriate window, press **Alt** to select the File menu in the menu bar.
2. Use the **Right Arrow** and **Left Arrow** keys to move horizontally to the Format menu.
3. Press **Down Arrow** to expand the Format menu.
4. Use the **Down Arrow** and **Up Arrow** keys to move vertically to the Sheet menu item.
5. Press **Right Arrow** to expand the Sheet sub-menu.
6. The Rename sub-menu item appears already selected. (If another item in the same sub-menu is required, use the **Down Arrow** and **Up Arrow** keys to move vertically to that item.)
7. Press **Enter** to execute the selected action.

## Windows Taskbar: Auto-hide

The Windows taskbar should *always* be in the auto-hide mode when using the instrument application. If the taskbar is *not* set to auto-hide, the lower part of the instrument display is obscured by the taskbar.

If a mouse is attached to the instrument, and you move the mouse cursor to the bottom of the display (either deliberately or accidentally), the taskbar automatically appears. Provided that the taskbar is in auto-hide mode, you can make it disappear again by moving the mouse cursor away from the bottom of the screen.

If at any time the Windows taskbar is inadvertently set to the non-auto-hide mode, you can restore the auto-hide behavior by doing the following:

1. Click Start > Control Panel. If not using a mouse, press **Ctrl+Esc**.
2. If the Control Panel window appears in Classic View, click Taskbar and Start Menu. If the Control Panel window appears in Category View, click Appearance and Themes > Taskbar and Start Menu. If not using a mouse, use the shortcut key combinations specified in the Section “Windows Shortcuts (Key Combinations)” on page 74 to make these selections.
3. The Taskbar and Start Menu Properties dialog appears. Select the Taskbar tab.
4. Check the Auto-hide the taskbar check box. If you are not using a mouse, press **Tab** repeatedly until the auto-hide option is selected, then press **Select** to toggle the check box state.



5. Click or select OK to apply the change and close the dialog.

## The Windows Startup Folder

All Windows XP systems include a special folder, called the Startup folder. If a program, or a shortcut to a program, is placed in the Startup folder (either by Windows itself, or by a third-party application, or by any user), that program automatically runs every time Windows is restarted.

When your instrument is first configured by Agilent, shortcuts to the appropriate application software and supporting programs are placed in the Startup folder. The exact contents of the Startup folder depends on the options you purchased with your instrument.

---

**IMPORTANT**You should *never* delete items that appear in the Startup folder, or move any item from the Startup folder to another folder. Deleting or moving any item in the Startup folder may cause applications not to start automatically when Windows is restarted, or may cause certain options to be unavailable when using the instrument.

---

If you wish to view the contents of the Startup folder, do one of the following:

- *Either* click Start, All Programs, then select Startup, *or*,
- Click Start, My Computer, then navigate to the folder C:\Documents and Settings\All Users\Start Menu\Programs\Startup. (Note that additional startup items may *also* appear in the corresponding startup folder for the user that is currently logged on. For example, the startup folder for the administrator user is C:\Documents and Settings\administrator\Start Menu\Programs\Startup.)



---

## 6 System Key

This key accesses a menu of the RF Preselector functions available using the softkeys.

During standalone mode (no master connection with PSA), you can access the System menu. When there is a connection established with the PSA, the instrument will be in remote mode. You will need to press the “local” key to access the front-panel softkeys and hardkeys. The System menu is the default panel.

Key Path

Front-panel key

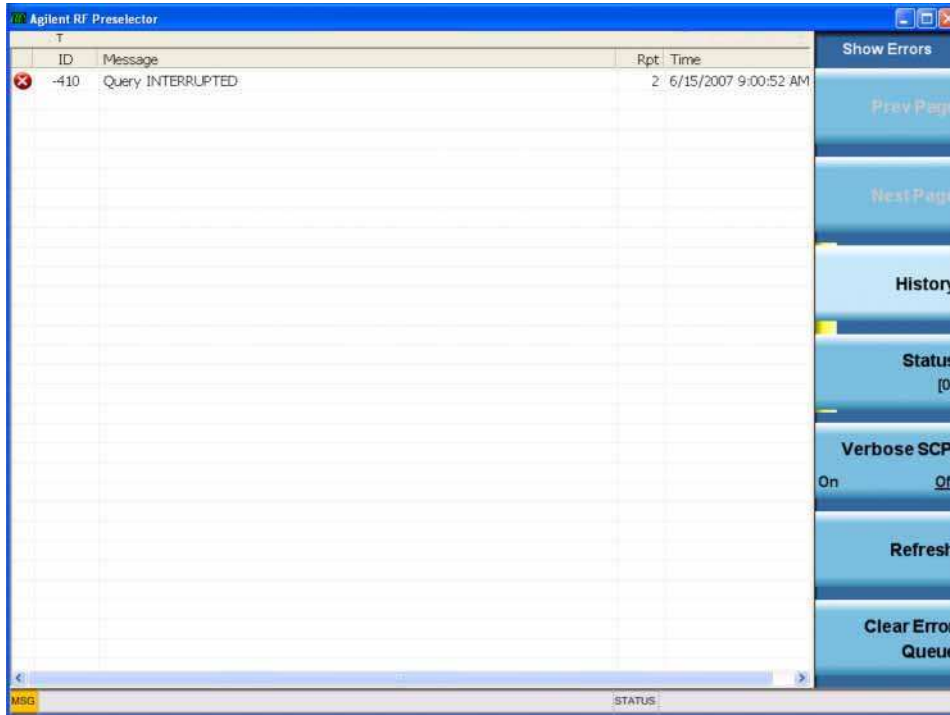




## History

Brings up a screen displaying the event log in chronological order, with the newest event at the top.

The history queue holds up to 100 messages. If the queue extends onto a second page, a scroll bar will appear to allow scrolling with a mouse. Time is displayed to the second.



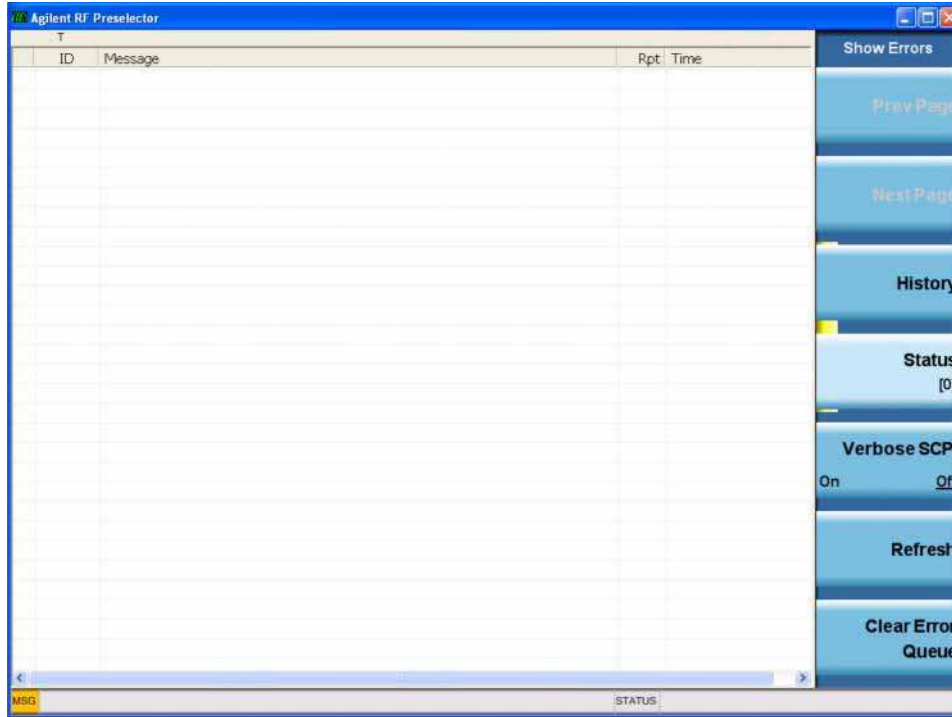
Key Path

System, Show, Errors

System Key  
Show

## Status

Brings up a screen summarizing the status conditions currently in effect. Time is displayed to the second. The Status key has a second line which shows a number in [square brackets]. This is the number of currently open status items. This example indicates that there are currently no open status items.



The fields on the Errors Status display are:

Type (unlabeled)

Displays the icon identifying the event or condition as an error or warning.

### ID

Displays the error number.

### Message

Displays the message text.

### Repeat (RPT)

This field shows the number of consecutive instances of the event, uninterrupted by other events. In other words, if an event occurs 5 times with no other intervening event, the value of repeat will be 5.

If the value of Repeat is 1 the field does not display. If the value of Repeat is >1, the time and date shown are those of the most recent occurrence. If the value of repeat reaches 999,999 it stops there.



## System Key Show

### Error List (Remote query only)

This remote command is used to query and delete the earliest error.

**Remote Command:** :SYSTem:ERRor[:NEXT]?

**Remote Command Notes:** Accesses the list of the last 30 errors reported. The earliest entry will be retrieved and deleted from the error list. If the same error message occurs several times the error message will be added several times to the list as a new error message. If the error queue overflows, the last error in the queue is replaced with error

-350,"Queue overflow"

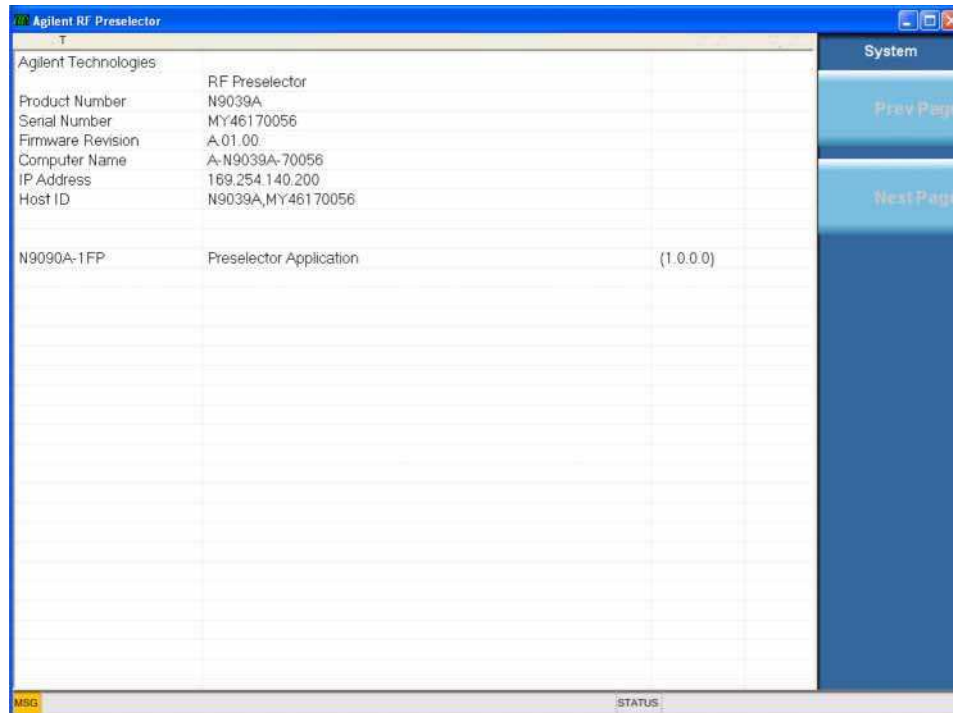
Any time the queue overflows, the least recent errors remain in the queue, and the most recent error is discarded.

**Example:** :SYST:ERR?

### System

The show System screen displays a list of installed options.

The screen is formatted into two groupings: product descriptive information and options tied to the hardware.



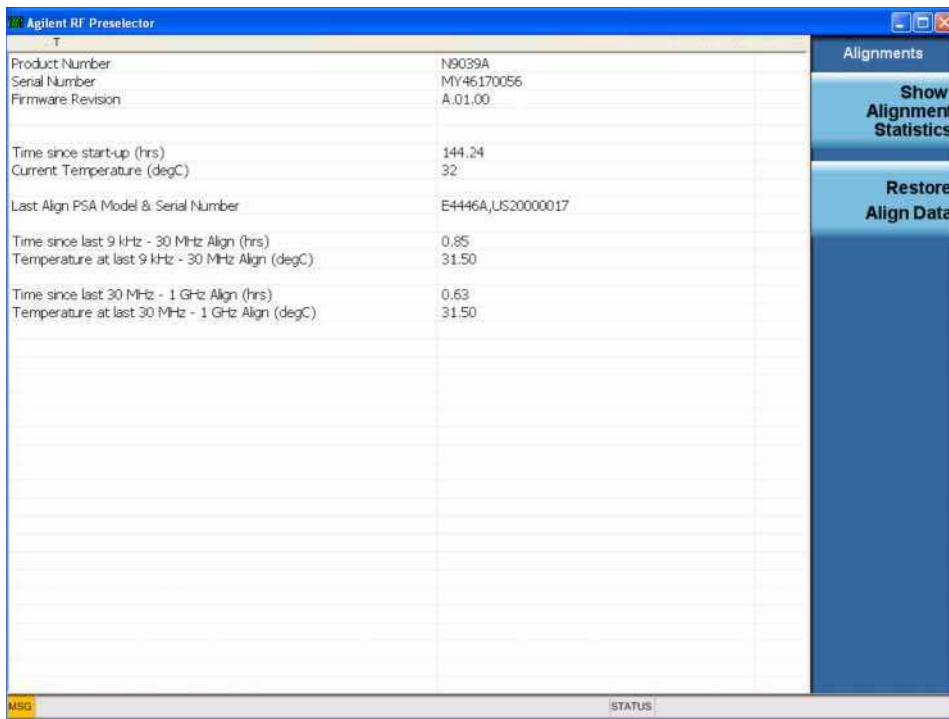
Key Path

System, Show





The display is similar to the following:



Key Path **System, Alignments**

### Restore Align Data

Initializes the alignment data to the factory default values. This action is normally not necessary. It is recommended if alignment errors occur. If alignment errors continue to occur after Restore Align Data, the instrument is in need of repair.

You will be prompted to confirm action before setting the alignment data to factory defaults:



Remote Command :CALibration:DATA:DEfault

Example :CAL:DATA:DEF

Key Path **System**

---

## IO Config

Activates a menu for identifying and changing the I/O configuration for SCPI remote control of GPIB and LAN. USB port is also available for remote control, but requires no configuration.

Configuration of the instrument's LAN can be performed using the Windows XP® Control Panel. Using the Control Panel, the LAN can be configured for many settings (DHCP, Gateway, Subnet Mask, and so forth).

The IP Address is available in several Windows Dialogs, such as My Computer, and is also listed in the Show Hardware screen.

Key Path	System
----------	--------

## GPIB Address

Set and query the instrument GPIB address.

<b>Remote Command</b>	:SYSTem:COMMunicate:GPIB[1] [:SELF] :ADDRess <integer> :SYSTem:COMMunicate:GPIB[1] [:SELF] :ADDRess?
-----------------------	--

Example	:SYST:COMM:GPIB:ADDR 20 :SYST:COMM:GPIB:ADDR?
---------	--

Min	0
-----	---

Max	30
-----	----

Key Path	System, I/O Config
----------	--------------------

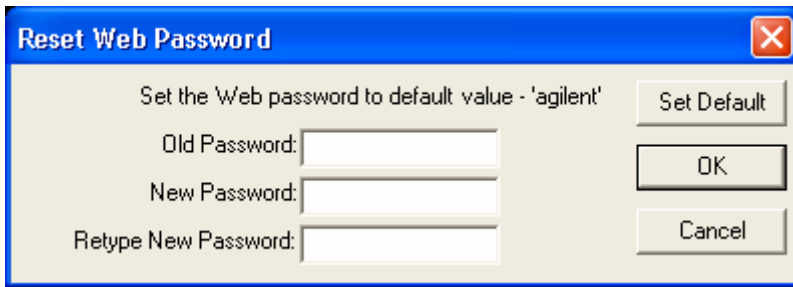
## Reset Web Password

The embedded web server contains certain capability which are password protected; modifying the LAN configuration of the instrument, and access to web pages that can change the settings of the instrument. The default password from the factory is 'agilent' (without the quotes). The control provided here is the means to set the web password as the user desires, or to reset the password to the factory default.

Selecting Reset Web Password brings up a control for resetting the password as the user desires, or to the factory default. An external keyboard is required to change the password from the factory default of



'agilent' or to set a new password that contains alphabetic characters. The control is:



If this control is entered without an external keyboard or mouse connected, you can cancel the control by pressing the Cancel (ESC) hardkey.

Mode	All
Key Path	System, I/O Config

### SCPI Socket Control Port (Remote Command Only)

Returns the TCP/IP port number of the control socket associated with the SCPI socket session. This query enables you to obtain the unique port number to open when a device clear is to be sent to the instrument. Every time a connection is made to the SCPI socket, the instrument creates a peer control socket. The port number for this socket is random. The user must use this command to obtain the port number of the control socket. To force a device clear on this socket, open the port and send the string "DCL" to the instrument.

If this SCPI command is sent to a non SCPI Socket interface, then 0 is returned.

Mode	All
<b>Remote Command</b>	:SYSTem:COMMunicate:LAN:SCPI:SOCKET:CONTRol?
Example	:SYST:COMM:LAN:SCPI:SOCK:CONT?
Preset	This is unaffected by Preset or "Restore System Defaults->Misc".
State Saved	No
Range	0 to 65534

### Query USB Connection (Remote Command Only)

Enables you to determine the speed of USB connection.

Mode	All
<b>Remote Command</b>	:SYSTem:COMMunicate:USB:CONNECTION?
Example	:SYST:COMM:USB:CONN?

Remote Command Notes	NONE – Indicates no USB connection has been made.  LSPeed – Indicates a USB low speed connection (1.5 Mbps). Note: this is reserved for future use, the T+M488 protocol is not supported on low speed connections.  HSPeed – Indicates that a USB high speed connection (480 Mbps) has been negotiated.  FSPeed – Indicates that a USB full speed connection (12 Mbps) has been negotiated.
State Saved	No
Range	NONE LSPeed HSPeed FSPeed

### USB Connection Status (Remote Command Only)

Enables you to determine the current status of the USB connection.

Mode	All
<b>Remote Command</b>	:SYSTem:COMMunicate:USB:STATus?
Example	:SYST:COMM:USB:STAT?
Remote Command Notes	SUSPended – Indicates that the USB bus is currently in its suspended state. The bus is in the suspended state when:  The bus is not connected to any controller  The controller is currently powered off  The controller has explicitly placed the USB device into the suspended state.  When in the suspended state, no USB activity, including start of frame packets are received.  ACTive – Indicates that the USB device is in the active state. When the device is in the active state, it is receiving periodic start of frames but it isn't necessarily receiving or transmitting data.
State Saved	No
Range	SUSPended ACTive

### USB Packet Count (Remote Command Only)

Enables you to determine the number of packets received and transmitted on the USB bus.

Mode	All
<b>Remote Command</b>	:SYSTem:COMMunicate:USB:PACKets?
Example	:SYST:COMM:USB:PACK?

Remote Command Notes      Two integers are returned. The first is the number of packets received since application invocation, the second is the number of packets transmitted since application invocation. If no packets have been received or transmitted the response is 0,0.

The packet count is initialized to 0,0 when the instrument application is started.

State Saved                      No

---

## Control Panel

Opens the windows Control Panel. Once you get into the Control Panel, IP Configuration type (Dynamic or Static), IP Address, Gateway Address and Subnet Mask of the instrument can be changed if you have a mouse and keyboard plugged in.

Key Path

System

---

## Licensing

Opens the license explorer. It shows Feature, Description, Revision, License Type, Expiration Date and the Alert date in the right Panel.

Key Path

System

## Diagnostics

The Diagnostics menu gives you access to basic diagnostic capabilities that can assist in the initial troubleshooting of instrument malfunctions.

Key Path **System**

### Show Hardware Statistics

Provides a display of various hardware statistics. The statistics include the following:

- Mechanical relay cycles
- High and Low temperature extremes
- Elapsed time that the instrument has been powered-on (odometer)

The statistics are displayed, along with the instrument product number, serial number, and firmware revision. The values which are displayed are only updated when the Show Hardware Statistics screen is invoked, they are not updated while the Show Alignment Statistics screen is being displayed. However, the remote commands which access this information obtain current values.

The display is similar to the following:

Component Name	Value
3-port Mech Relay	40
4-port Mech Relay	15
Atten A Relay Count Total	225
2.5dB Atten	99
5dB Atten	49
10dB Atten	59
1st 20dB Atten	9
2nd 20dB Atten	9
Atten B Relay Count Total	204
Input Switch	9
2.5dB Atten	99
5dB Atten	49
1st 10dB Atten	10
2nd 10dB Atten	9
3rd 10dB Atten	19
20dB Atten	9
High temperature operating extreme	34
Low temperature operating extreme	24.5
Elapsed Time (On-Time)(hours)	162

Each of the hardware statistic items can be queried.

Key Path **System, Diagnostics**

### Query the Low Operating Temperature Extremes (Remote Command Only)

Queries the low operating temperature extreme. The value survives a power-cycle and is the temperature extreme encountered since the value was reset by the factory or service center.

Key Path	System, Diagnostics, Show Hdwr Statistics
<b>Remote Command</b>	:SYSTem:TEMPerature:LEXTreme?
Remote Command Notes	Value is in degrees Centigrade at which the lowest operating temperature has been recorded since 1st power-up.
Example	:SYST:TEMP:LEXT?

### Query the High Operating Temperature Extremes (Remote Command Only)

Queries the high operating temperature extreme. The value survives a power-cycle and is the temperature extreme encountered since the value was reset by the factory or service center.

Key Path	System, Diagnostics, Show Hdwr Statistics
<b>Remote Command</b>	:SYSTem:TEMPerature:HEXTreme?
Remote Command Notes	Value is in degrees Centigrade at which the highest operating temperature has been recorded since 1st power-up.
Example	:SYST:TEMP:HEXT?

### Query the Elapsed Time since 1st power on (Remote Command Only)

Queries the elapsed on-time since 1st power-on (odometer).

Key Path	System, Diagnostics, Show Hdwr Statistics
<b>Remote Command</b>	:SYSTem:PON:ETIMe?
Example	:SYST:PON:ETIM?

---

## Remote Command Only Functions

These commands are used for functionality that is only available through remote access.

### Lock the Front Panel keys (Remote Command Only)

Disables the instrument keyboard to prevent local input when the instrument is controlled remotely. An annunciator reading “K” for ‘Klock” alerts you that the keyboard is locked. Klock is similar to the GPIB Local Lockout function; namely that no front panel keys are active with the exception of the Power Standby key. (The instrument must be allowed to be turned-off if Klock is ON.) The Klock command is used in remote control situations where Local Lockout cannot be used.

Although the primary intent of Klock is to lock out the front panel, it will lock-out externally connected keyboards through the USB connection. Klock has no effect on externally connected pointing devices (mice).

The front panel Local key has no effect if Klock is ON.

<b>Remote Command:</b>	:SYSTem:KLOCK ON OFF 0 1 :SYSTem:KLOCK?
Preset:	OFF
Preset/Default (L/P):	Initialized to OFF at startup, unaffected by Preset
Remote Command Notes:	Keyboard lock remains in effect until turned-off or instrument is power-cycled
Example:	:SYST:KLOC ON :SYST:KLOC?

### List installed Options (Remote Command Only)

Lists the installed options that pertain to the instrument.

<b>Remote Command:</b>	:SYSTem:OPTions?
Restriction and Notes:	The return string is the installed hardware options. For example: “” for N-type connector or “BAB” for APC 3.5mm connector. :SYSTem:OPTions? and *OPT? are synonymous.
Saved State:	No
Example:	:SYST:OPT?



## Date (Remote Command Only)

The recommended access to the instrument's Date, Time, and Time zone is through the Windows native control (Control Panel or accessing the Task bar). You may also access this information remotely.

Sets or queries the instrument's date.

**Remote Command:**                   :SYSTem:DATE "<year>, <month>, <day>"  
   :SYSTem:DATE?

Remote Command Notes:           <year> is the four digit representation of year. For example, 2006  
   <month> is the two digit representation of month. For example, 01 to 12  
   <day> is the two digit representation of day. For example, 01 to 28, 29, 30, or 31 (depending on the month and year)

Example:                               :SYST:DATE "2006,03,20"  
   :SYST:DATE?

## Time (Remote Command Only)

This SCPI is used to set or queries the instrument's time.

**Remote Command:**                   :SYSTem:TIME "<hour>, <minute>, <second>"  
   :SYSTem:TIME?

Remote Command Notes:           The time must be in UTC time (Coordinated Universal Time, a.k.a. Greenwich Mean Time (GMT)).  
   <hour> is the two digit representation of the hour in 24 hour format  
   <minute> is the two digit representation of minute  
   <second> is the two digit representation of second

Example:                               :SYST:TIME "09,46,30"  
   :SYST:TIME?

## Full Screen

Turns the full screen on or off.

Key Path	<b>Front-panel key</b>
<b>Remote Command</b>	DISPlay:FSCReen[:STATe] ON OFF 1 0
Preset	OFF
Example	DISP:FSCR 1

System Key  
**Remote Command Only Functions**

---

## 7 Preset Key

The green Preset key causes a System Preset. The system preset is the most common way to get the instrument back to a known state. It does not affect any mode persistent settings or any system settings.

If any show screen is turned on while the preset key is pressed, the screen will be turned off and the default display (block diagram) will be shown. The software panel will be reset to the system panel.

Key Path	<b>Front-panel key</b>
<b>Remote Command</b>	:SYSTem:PRESet
Remote Command Notes	Clears all pending OPC bits. The Status Byte is set to 0.
Example	:SYST:PRES

Preset Key

---

## 8 IEEE Common Commands

The following topics can be found in this chapter:

- “Clear Status” on page 102
- “Standard Event Status Enable ” on page 102
- “Standard Event Status Register Query ” on page 103
- “Operation Complete ” on page 104
- “Query Instrument Options ” on page 104
- “Reset ” on page 104
- “Service Request Enable ” on page 105
- “Status Byte Query ” on page 105
- “Wait-to-Continue ” on page 106

## IEEE Common Commands

Numeric values for bit patterns can be entered using decimal or hexadecimal representations. (that is 0 to 32767 is equivalent to #H0 to #H7FFF).

### Clear Status

Clears the status byte register. It does this by emptying the error queue and clearing all bits in all of the event registers. The status byte register summarizes the states of the other registers. It is also responsible for generating service requests.

<b>Remote Command</b>	*CLS
Example	*CLS Clears the error queue and the Status Byte Register.
Remote Command Notes	For related commands, see the SYSTem:ERRor[:NEXT]? command. See also the STATus:PRESet command and all commands in the STATus subsystem.
Key Path	No equivalent key. Related key System, Show Errors, Clear Error Queue
SCPI Status Bits/OPC Dependencies	Resets all bits in all event registers to 0, which resets all the status byte register bits to 0 also.

### Standard Event Status Enable

Selects the desired bits from the standard event status enable register. This register monitors I/O errors and synchronization conditions such as operation complete, request control, query error, device dependent error, status execution error, command error and power on. The selected bits are OR'd to become a summary bit (bit 5) in the byte register which can be queried.

The query returns the state of the standard event status enable register.

<b>Remote Command</b>	*ESE <integer> *ESE?
Example	*ESE 36 Enables the Standard Event Status Register to monitor query and command errors (bits 2 and 5). *ESE? Returns a 36 indicating that the query and command status bits are enabled.
Remote Command Notes	For related commands, see the STATus subsystem and SYSTem:ERRor[:NEXT]? commands.
Preset	255
State Saved	Not saved in state.

Min	0
Max	255
Key Path	No equivalent key. Related key System, Show Errors, Clear Error Queue
SCPI Status Bits/OPC Dependencies	Event Enable Register of the Standard Event Status Register.

## Standard Event Status Register Query

Queries and clears the standard event status event register. (This is a destructive read.) The value returned is a hexadecimal number that reflects the current state (0/1) of all the bits in the register.

<b>Remote Command</b>	*ESR?
Example	*ESR? Returns a 1 if there is either a query or command error, otherwise it returns a zero.
SCPI Status Bits/OPC Dependencies	Standard Event Status Register (bits 0 – 7).
Remote Command Notes	For related commands, see the STATus subsystem commands.
Preset	0
Min	0
Max	255

## Identification Query

Returns a string of instrument identification information. The string will contain the model number, serial number and firmware revision.

The response is organized into four fields separated by commas. The field definitions are as follows:

- Manufacturer
- Model
- Serial number
- Firmware version

<b>Remote Command</b>	*IDN?
Example	*IDN? Returns instrument identification information, such as:  Agilent Technologies,N9039A,US00000713,A.01.02
Key Path	No equivalent key. See related key System, Show System.

## Operation Complete

The \*OPC command sets bit 0 in the standard event status register (SER) to “1” when pending operations have finished, that is when all overlapped commands are complete. It does not hold off subsequent operations. You can determine when the overlapped commands have completed either by polling the OPC bit in SER, or by setting up the status system such that a service request (SRQ) is asserted when the OPC bit is set.

The \*OPC? query returns a “1” after all the current overlapped commands are complete. So it holds off subsequent commands until the “1” is returned, then the program continues. This query can be used to synchronize events of other instruments on the external bus.

<b>Remote Command</b>	*OPC
	*OPC?
SCPI Status Bits/OPC Dependencies	Not global to all remote ports or front panel. *OPC only considers operation that was initiated on the same port as the *OPC command was issued from.
	*OPC is an overlapped command, but *OPC? is sequential.

## Query Instrument Options

Returns a string of all the installed instrument options. It is a comma separated list with quotes, such as: “BAB”. To be IEEE compliant, this command should return an arbitrary ascii variable that would not begin and end with quotes. But the quotes are needed to be backward compatible with previous SA products and software. So, the actual implementation will use arbitrary ascii. But quotes will be sent as the first and last ascii characters that are sent with the comma-separated option list.

<b>Remote Command</b>	*OPT?
-----------------------	-------

## Reset

This command does a Mode Preset. It does not change the mode, and only resets the parameters for the current mode. And it does not do a \*CLS which would clear the STATus bits and the error queue.

<b>Remote Command</b>	*RST
Example	*RST Presets the settings of the current mode.
Restriction and Notes	See the Mode Preset key description for more details about the implementation.



## Service Request Enable

This command enables the desired bits of the service request enable register.

The query returns the value of the register, indicating which bits are currently enabled.

<b>Remote Command</b>	*SRE <integer> *SRE?
Example	*SRE 22 Enables bits 1, 2, and 4 in the service request enable register.
SCPI Status Bits/OPC Dependencies	Service Request Enable Register (all bits, 0 – 7).
Remote Command Notes	For related commands, see the STATus subsystem and SYSTem:ERRor[:NEXT]? commands.
Preset	255
Min	0
Max	255

## Status Byte Query

Returns the value of the status byte register without erasing its contents.

<b>Remote Command</b>	*STB?
Example	*STB? Returns a decimal value for the bits in the status byte register.  For example, if a 16 is returned, it indicates that bit 5 is set and one of the conditions monitored in the standard event status register is set.
SCPI Status Bits/OPC Dependencies	Status Byte Register (all bits, 0 – 7).
Remote Command Notes	See related command *CLS.

## Wait-to-Continue

This command causes the instrument to wait until all overlapped commands are completed before executing any additional commands. There is no query form for the command.

<b>Remote Command</b>	*WAI
Example	INIT:CONT OFF; INIT;*WAI Sets the instrument to single sweep. Starts a sweep and waits for its completion.
SCPI Status Bits/OPC	Not global to all remote ports or front panel. *OPC only
Dependencies	considers operation that was initiated on the same port as the *OPC command was issued from.

---

## 9 Status Subsystem

The following topics can be found in this chapter:

- “What Are Status Registers” on page 108
- “What Are Status Register SCPI Commands” on page 109
- “How to Use the Status Registers” on page 109
- “Using the Service Request (SRQ) Method” on page 112
- “Status Register System” on page 112
- “The Status Byte Register” on page 113
- “Standard Event Status Register” on page 116
- “Operation and Questionable Status Registers” on page 118
- “Questionable Status Register” on page 118
- “Preset the Status Byte ” on page 119
- “Questionable Register ” on page 119
- “Questionable Calibration Register ” on page 121
- “Questionable Calibration Extended Needed Register ” on page 124
- “Questionable Power Register ” on page 126

---

## STATus Subsystem (No equivalent front panel keys)

### Detailed Description

The STATus subsystem remote commands set and query the status hardware registers. This system of registers monitors various events and conditions in the instrument. Software written to control the instrument may need to monitor some of these events and conditions.

---

**NOTE** All status register commands are sequential. Most commands can be started immediately and will overlap with any existing commands that are already running. This is not true of status commands. All the commands in the spectrum analyzer are assumed to be overlapped unless a command description specifically says that it is sequential.

---

### What Are Status Registers

The status system contains multiple registers that are arranged in a hierarchical order. The lower-level status registers propagate their data to the higher-level registers in the data structures by means of summary bits. The status byte register is at the top of the hierarchy and contains general status information for the instrument's events and conditions. All other individual registers are used to determine the specific events or conditions. For a diagram of the registers and their interconnections, see above.

The operation and questionable status registers are sets of registers that monitor the overall instrument condition. They are accessed with the STATus:OPERation and STATus:QUESTionable commands in the STATus command subsystem. Each register set is made up of five registers:

- **Condition Register** It reports the real-time state of the signals monitored by this register set. There is no latching or buffering for a condition register.
- **Positive Transition Register** This filter register controls which signals will set a bit in the event register when the signal makes a low to high transition (when the condition bit changes from 0 to 1).
- **Negative Transition Register** This filter register controls which signals will set a bit in the event register when the signal makes a high to low transition (when the condition bit changes from 1 to 0).
- **Event Register** It latches any signal state changes, in the way specified by the filter registers. Bits in the event register are never cleared by signal state changes. Event registers are cleared when read. They are also cleared by \*CLS and by presetting the instrument.
- **Event Enable Register** It controls which of the bits, being set in the event register, will be summarized as a single output for the register set. Summary bits are then used by the next higher register.

The STATus:QUESTionable registers report abnormal operating conditions. The status register hierarchy is:

1. The summary outputs from the six STATus:QUESTionable:<keyword> detail registers are inputs to the STATus:QUESTionable register.
2. The summary output from the STATus:QUESTionable register is an input to the Status Byte Register. See the overall system in Figure at the beginning of this section.

The STATus:OPERation register set has no summarized inputs. The inputs to the STATus:OPERation:CONDition register indicate the real time state of the instrument. The STATus:OPERation:EVENt register summary output is an input to the Status Byte Register.

### What Are Status Register SCPI Commands

Most monitoring of the instrument conditions is done at the highest level using the IEEE common commands indicated below. Complete command descriptions are available in the IEEE commands section at the beginning of the language reference. Individual status registers can be set and queried using the commands in the STATus subsystem of the language reference.

- \*CLS (clear status) clears the status byte by emptying the error queue and clearing all the event registers.
- \*ESE, \*ESE? (event status enable) sets and queries the bits in the enable register part of the standard event status register.
- \*ESR? (event status register) queries and clears the event register part of the standard event status register.
- \*OPC, \*OPC? (operation complete) sets the standard event status register to monitor the completion of all commands. The query stops any new commands from being processed until the current processing is complete, then returns a '1'.
- \*PSC, \*PSC? (power-on state clear) sets the power-on state so that it clears the service request enable register and the event status enable register at power on.
- \*SRE, \*SRE? (service request enable) sets and queries the value of the service request enable register.
- \*STB? (status byte) queries the value of the status byte register without erasing its contents.

### How to Use the Status Registers

A program often needs to be able to detect and manage error conditions or changes in instrument status. There are two methods you can use to programmatically access the information in status registers:

- The polling method
- The service request (SRQ) method

In the polling method, the instrument has a passive role. It only tells the controller that conditions have changed when the controller asks the right question. In the SRQ method, the instrument takes a more active role. It tells the controller when there has been a condition change without the controller asking. Either method allows you to monitor one or more conditions.

The polling method works well if you do not need to know about changes the moment they occur. The SRQ method should be used if you must know immediately when a condition changes. To detect a change using the polling method, the program must repeatedly read the registers.

Use the SRQ method when:

- you need time-critical notification of changes
- you are monitoring more than one device which supports SRQs
- you need to have the controller do something else while waiting

- you can't afford the performance penalty inherent to polling

Use polling when:

- your programming language/development environment does not support SRQ interrupts
- you want to write a simple, single-purpose program and don't want the added complexity of setting up an SRQ handler
- To monitor a condition:
  1. Determine which register contains the bit that reports the condition.
  2. Send the unique SCPI query that reads that register.
  3. Examine the bit to see if the condition has changed.

You can monitor conditions in different ways.

- Check the current instrument hardware and firmware status.

Do this by querying the condition registers which continuously monitor status. These registers represent the current state of the instrument. Bits in a condition register are updated in real time. When the condition monitored by a particular bit becomes true, the bit is set to 1. When the condition becomes false, the bit is reset to 0.

- Monitor a particular condition (bit).

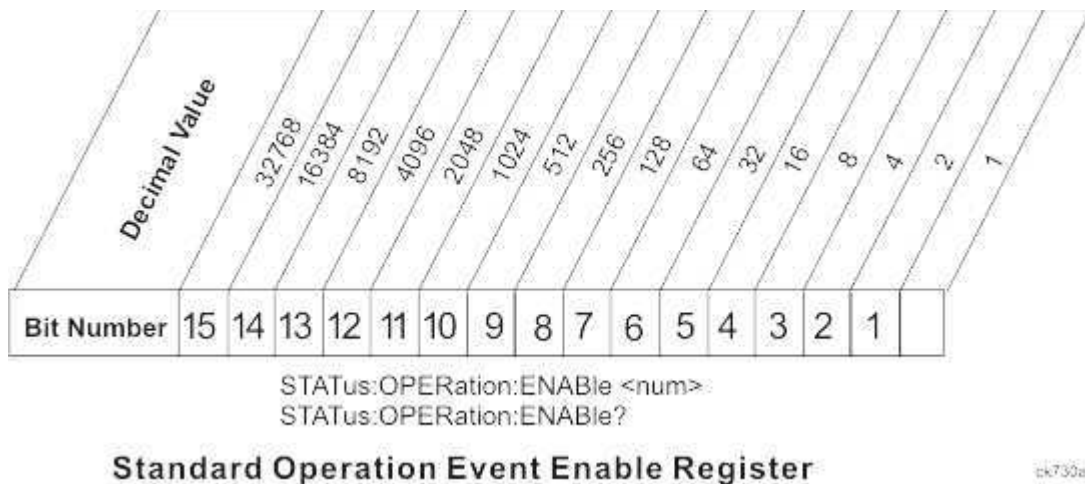
You can enable a particular bit(s), using the event enable register. The instrument will then monitor that particular condition(s). If the bit becomes true (0 to 1 transition) in the event register, it will stay set until the event register is cleared. Querying the event register allows you to detect that this condition occurred even if the condition no longer exists. The event register can only be cleared by querying it or sending the \*CLS command.

- Monitor a particular type of change in a condition (bit).
  - The transition registers are preset to register if the condition goes from 0 to 1 (false to true, or a positive transition).
  - This can be changed so the selected condition is detected if the bit goes from 1 to 0 (true to false, or a negative transition).
  - It can also be set for both types of transitions occurring.
  - Or it can be set for neither transition. If both transition registers are set to 0 for a particular bit position, that bit will not be set in the event register for either type of change.

### Using a Status Register

Each bit in a register is represented by a numerical value based on its location. See figure below. This number is sent with the command to enable a particular bit. If you want to enable more than one bit, you would send the sum of all the bits that you want to monitor.

Figure: Status Register Bit Values



Bit 15 is not used to report status.

Example 1:

1. To enable bit 0 and bit 6 of standard event status register, you would send the command `*ESE 65` because  $1 + 64 = 65$ .
2. The results of a query are evaluated in a similar way. If the `*STB?` command returns a decimal value of 140, ( $140 = 128 + 8 + 4$ ) then bit 7 is true, bit 3 is true and bit 2 is true.

Example 2:

1. Suppose you want to know if an Auto-trigger Timeout occurs, but you only cared about that specific condition. So you would want to know what was happening with bit 10 in the Status Questionable Integrity register, and not about any other bits.
2. It's usually a good idea to start by clearing all the status registers with `*CLS`.
3. Sending the `STAT:QUES:INT:ENAB 1024` command lets you monitor only bit 10 events, instead of the default monitoring all the bits in the register. The register default is for positive transition events (0 to 1 transition). That is, when an auto-trigger timeout occurs. If instead, you wanted to know when the Auto-trigger timeout condition is cleared, then you would set the `STAT:QUES:INT:PTR 0` and the `STAT:QUES:INT:NTR 32767`.
4. So now the only output from the Status Questionable Integrity register will come from a bit 10 positive transition. That output goes to the Integrity Sum bit 9 of the Status Questionable register.
5. You can do a similar thing with this register to only look at bit 9 using, `STAT:QUES:ENAB 512`.
6. The Status Questionable register output goes to the "Status Questionable Summary" bit 3 of the Status Byte Register. The output from this register can be enabled using the `*SRE 8` command.
7. Finally, you would use the serial polling functionality available for the particular bus/software that you are using to monitor the Status Byte Register. (You could also use `*STB?` to poll the Status Byte Register.)

## Using the Service Request (SRQ) Method

Your language, bus and programming environment must be able to support SRQ interrupts. (For example, BASIC used with VXI-11.3 (GPIB over LAN). When you monitor a condition with the SRQ method, you must:

1. Determine which bit monitors the condition.
2. Determine how that bit reports to the request service (RQS) bit of the status byte.
3. Send SCPI commands to enable the bit that monitors the condition and to enable the summary bits that report the condition to the RQS bit.
4. Enable the controller to respond to service requests.

When the condition changes, the instrument sets its RQS bit. The controller is informed of the change as soon as it occurs. As a result, the time the controller would otherwise have used to monitor the condition can be used to perform other tasks. Your program determines how the controller responds to the SRQ.

**Generating a Service Request** To use the SRQ method, you must understand how service requests are generated. Bit 6 of the status byte register is the request service (RQS) bit. The \*SRE command is used to configure the RQS bit to report changes in instrument status. When such a change occurs, the RQS bit is set. It is cleared when the status byte register is queried using \*SRE? (with a serial poll.) It can be queried without erasing the contents with \*STB?.

When a register set causes a summary bit in the status byte to change from 0 to 1, the instrument can initiate the service request (SRQ) process. However, the process is only initiated if both of the following conditions are true:

- The corresponding bit of the service request enable register is also set to 1.
- The instrument does not have a service request pending. (A service request is considered to be pending between the time the instrument's SRQ process is initiated and the time the controller reads the status byte register.)

The SRQ process sets the SRQ true. It also sets the status byte's request service (RQS) bit to 1. Both actions are necessary to inform the controller that the instrument requires service. Setting the SRQ line only informs the controller that some device on the bus requires service. Setting the RQS bit allows the controller to determine which instrument requires service.

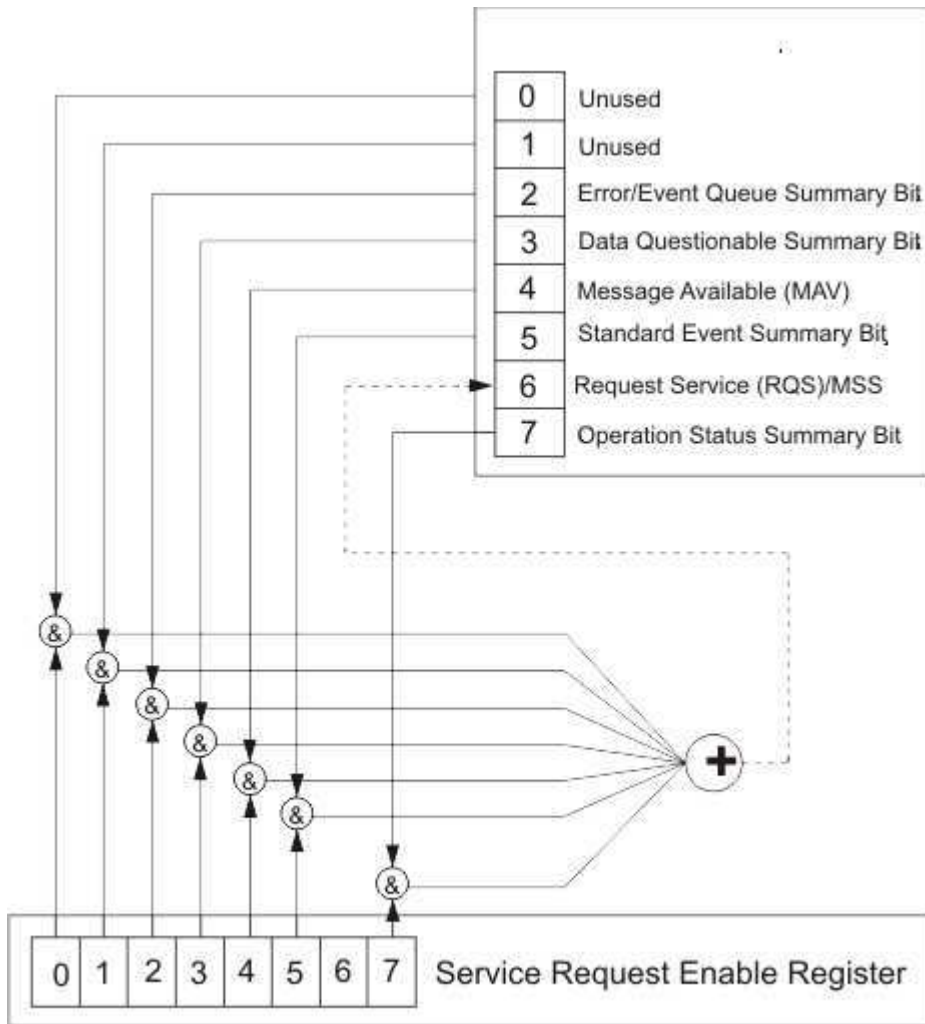
If your program enables the controller to detect and respond to service requests, it should instruct the controller to perform a serial poll when the SRQ is set true. Each device on the bus returns the contents of its status byte register in response to this poll. The device whose RQS bit is set to 1 is the device that requested service.

## Status Register System

The hardware status registers are combined to form the instrument status system. Specific status bits are assigned to monitor various aspects of the instrument operation and status. See the diagram of the status system above for information about the bit assignments and status register interconnections.



### The Status Byte Register



16x776a

The RQS bit is read and reset by a serial poll. The same bit position (MSS) is read, non-destructively by the \*STB? command. If you serial poll bit 6 it is read as RQS, but if you send \*STB it reads bit 6 as MSS. For more information refer to IEEE 488.2 standards, section 11.

Status Subsystem  
**STATus Subsystem (No equivalent front panel keys)**

	Description	Standard Operation Status Summary Bit	Request Service (RQS) Summary Bit	Standard Event Status Summary Bit	Message Available (MAV)	Data Questionable Status Summary Bit	Error/Event Queue Summary Bit	Unused	Unused
Bit Number	7	6	5	4	3	2	1	0	0

\*STB?

**Status Byte Register**

ck725a

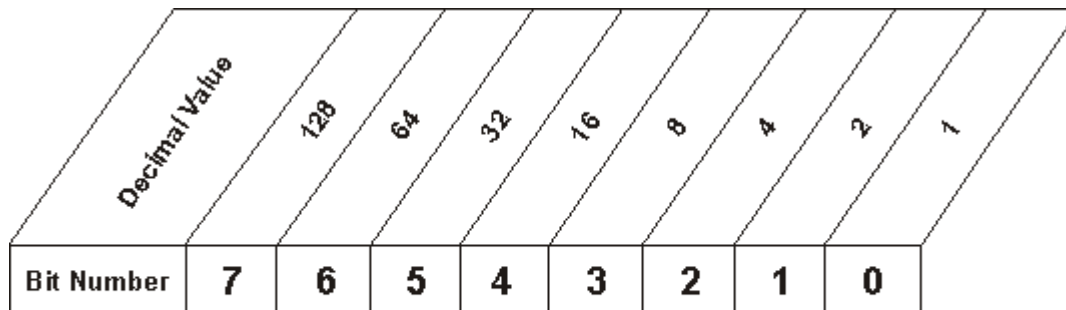
- |      |   |
|------|---|
| Bit  | Description   |
| 0, 1 | These bits are always set to 0.   |
| 2    | A 1 in this bit position indicates that the SCPI error queue is not empty which means that it contains at least one error message.  |
| 3    | A 1 in this bit position indicates that the data questionable summary bit has been set. The data questionable event register can then be read to determine the specific condition that caused this bit to be set.   |
| 4    | A 1 in this bit position indicates that the instrument has data ready in the output queue. There are no lower status groups that provide input to this bit.   |
| 5    | A 1 in this bit position indicates that the standard event summary bit has been set. The standard event status register can then be read to determine the specific event that caused this bit to be set.            |
| 6    | A 1 in this bit position indicates that the instrument has at least one reason to report a status change. This bit is also called the master summary status bit (MSS).  |
| 7    | A 1 in this bit position indicates that the standard operation summary bit has been set. The standard operation event register can then be read to determine the specific condition that caused this bit to be set. |

To query the status byte register, send the command \*STB?. The response will be the decimal sum of the bits which are set to 1. For example, if bit number 7 and bit number 3 are set to 1, the decimal sum of the 2 bits is 128 plus 8. So the decimal value 136 is returned. The \*STB command does not clear the status register.

In addition to the status byte register, the status byte group also contains the service request enable register. This register lets you choose which bits in the status byte register will trigger a service request.

Send the `*SRE <integer>` command where `<integer>` is the sum of the decimal values of the bits you want to enable plus the decimal value of bit 6. For example, assume that you want to enable bit 7 so that whenever the standard operation status register summary bit is set to 1 it will trigger a service request. Send the command `*SRE 192` (because  $192 = 128 + 64$ ). You must always add 64 (the numeric value of RQS bit 6) to your numeric sum when you enable any bits for a service request. The command `*SRE?` returns the decimal value of the sum of the bits previously enabled with the `*SRE <integer>` command.

The service request enable register presets to zeros (0).

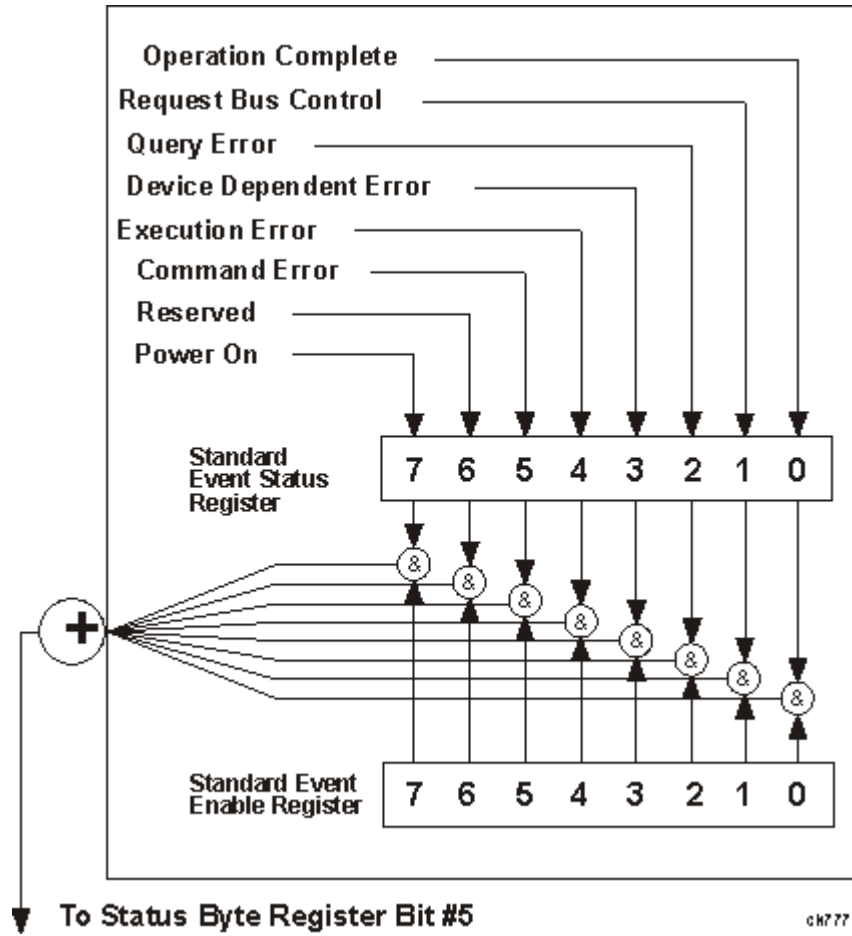


`*SRE <num>`  
`*SRE?`

### Service Request Enable Register

CH7263

### Standard Event Status Register



The standard event status register contains the following bits:

Bit Number	7	6	5	4	3	2	1	0
Description	Power On	Reserved	Command Error	Execution Error	Device Dependent Error	Query Error	Request Control	Operation Complete

\*ESR?

## Standard Event Status Register

ck727a

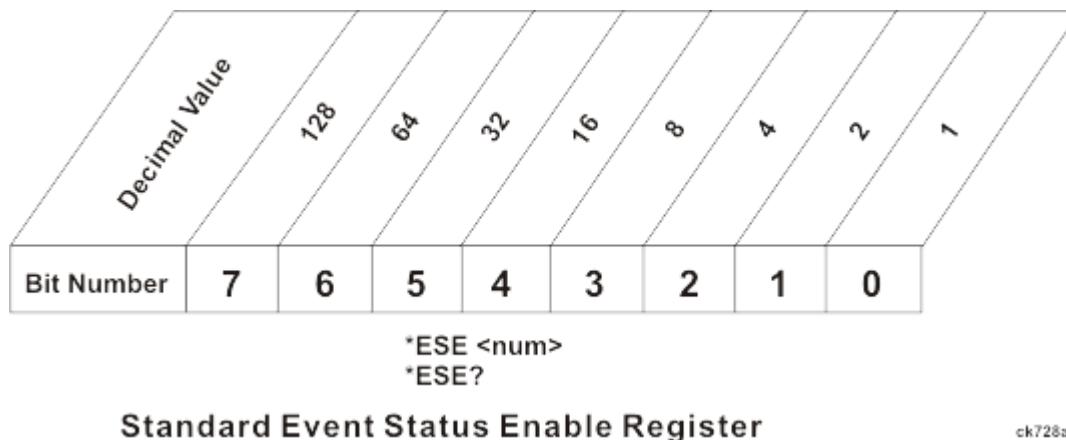
Bit	Description
0	A 1 in this bit position indicates that all pending operations were completed following execution of the *OPC command.
1	This bit is for GPIB handshaking to request control. Currently it is set to 0 because there are no implementations where the spectrum analyzer controls another instrument.
2	A 1 in this bit position indicates that a query error has occurred. Query errors have SCPI error numbers from -499 to -400.
3	A 1 in this bit position indicates that a device dependent error has occurred. Device dependent errors have SCPI error numbers from -399 to -300 and 1 to 32767.
4	A 1 in this bit position indicates that an execution error has occurred. Execution errors have SCPI error numbers from -299 to -200.
5	A 1 in this bit position indicates that a command error has occurred. Command errors have SCPI error numbers from -199 to -100.
6	A 1 in this bit position indicates that the LOCAL key has been pressed. This is true even if the instrument is in local lockout mode.
7	A 1 in this bit position indicates that the instrument has been turned off and then on.

The standard event status register is used to determine the specific event that set bit 5 in the status byte register. To query the standard event status register, send the command \*ESR?. The response will be the decimal sum of the bits which are enabled (set to 1). For example, if bit number 7 and bit number 3 are enabled, the decimal sum of the 2 bits is 128 plus 8. So the decimal value 136 is returned.

Status Subsystem  
**STATus Subsystem (No equivalent front panel keys)**

In addition to the standard event status register, the standard event status group also contains a standard event status enable register. This register lets you choose which bits in the standard event status register will set the summary bit (bit 5 of the status byte register) to 1. Send the \*ESE <integer> command where <integer> is the sum of the decimal values of the bits you want to enable. For example, to enable bit 7 and bit 6 so that whenever either of those bits is set to 1, the standard event status summary bit of the status byte register will be set to 1, send the command \*ESE 192 (128 + 64). The command \*ESE? returns the decimal value of the sum of the bits previously enabled with the \*ESE <integer> command.

The standard event status enable register presets to zeros (0).



### Operation and Questionable Status Registers

The operation and questionable status registers are registers that monitor the overall instrument condition. They are accessed with the STATUS:OPERation and STATUS:QUEStionable commands in the STATus command subsystem. See the figure at the beginning of this chapter.

#### Questionable Status Register

The questionable status register monitors the instrument's condition to see if anything questionable has happened to it. It is looking for anything that might cause an error or a bad measurement like a hardware problem, an out of calibration situation, or a unusual signal. All the bits are summary bits from lower-level event registers.

Bit	Condition	Operation
3	Power summary	The instrument hardware has detected a power unlevelled condition.
8	Calibration summary	The instrument has detected a hardware problem while doing the automatic internal alignment process.

## STATus Subsystem Command Descriptions

The STATus subsystem controls the SCPI-defined instrument status reporting structures. Each status register has a set of five commands used for querying or masking that particular register.

Numeric values for bit patterns can be entered using decimal or hexadecimal representations. (i.e. 0 to 32767 is equivalent to #H0 to #H7FFF. It is also equal to all ones, 11111111111111) See the SCPI Basics information about using bit patterns for variable parameters.

### Preset the Status Byte

Sets bits in most of the enable and transition registers to their default state. It presets all the Transition Filters, Enable Registers, and the Error/Event Queue Enable. It has no effect on Event Registers, Error/Event QUEue, IEEE 488.2 ESE, and SRE Registers as described in IEEE Standard 488.2–1992, IEEE Standard Codes, Formats, Protocols and Common Commands for Use with ANSI/IEEE Std 488.1–1987. New York, NY, 1992.

**Remote Command** :STATus:PRESet

Example STAT:PRES

### Questionable Register

#### Questionable Condition

This query returns the decimal value of the sum of the bits in the Questionable Condition register.

The data in this register is continuously updated and reflects the current conditions.

Mode All

**Remote Command** :STATus:QUESTionable:CONDition?

Example STAT:QUES:COND?

Preset 0

SCPI Status Bits/OPC Sequential command

Dependencies

#### Questionable Enable

This command determines which bits in the Questionable Event register will set the Questionable Status Summary bit (bit3) in the Status Byte Register. The variable <integer> is the sum of the decimal values of the bits you want to enable.

The preset condition is all bits in this enable register set to 0. To have any Questionable Events reported to the Status Byte Register, one or more bits need to be set to 1. The Status Byte Event Register should be queried after each measurement to check the Questionable Status Summary (bit 3). If it is equal to 1, a condition during the test may have made the test results invalid. If it is equal to 0, this indicates that no hardware problem or measurement problem was detected by the analyzer.

Mode All

Status Subsystem  
**STATUS Subsystem (No equivalent front panel keys)**

<b>Remote Command</b>	:STATus:QUEStionable:ENABle
	16 Sets the register so that temperature summary will be reported to the Status Byte Register
	:STATus:QUEStionable:ENABle?
Example	STAT:OPER:PTR 1 Align Now operation beginning will be reported to the Status Byte Register.
Preset	0
Min	0
Max	32767
SCPI Status Bits/OPC Dependencies	Sequential command

### Questionable Event Query

This query returns the decimal value of the sum of the bits in the Questionable Event register.

The register requires that the associated PTR or NTR filters be set before a condition register bit can set a bit in the event register. The data in this register is latched until it is queried. Once queried, the register is cleared.

Mode	All
<b>Remote Command</b>	:STATus:QUEStionable[:EVENT]?
Example	STAT:QUES?
Preset	0
SCPI Status Bits/OPC Dependencies	Sequential command

### Questionable Negative Transition

This command determines which bits in the Questionable Condition register will set the corresponding bit in the Questionable Event register when the condition register bit has a negative transition (1 to 0). The variable <integer> is the sum of the decimal values of the bits that you want to enable.

Mode	All
<b>Remote Command</b>	:STATus:QUEStionable:NTRansition <integer>
	:STATus:QUEStionable:NTRansition?
Example	STAT:QUES:NTR 16 Temperature summary 'questionable cleared' will be reported to the Status Byte Register.
Preset	0



Min	0
Max	32767
SCPI Status Bits/OPC Dependencies	Sequential command

### Questionable Positive Transition

This command determines which bits in the Questionable Condition register will set the corresponding bit in the Questionable Event register when the condition register bit has a positive transition (0 to 1). The variable <integer> is the sum of the decimal values of the bits that you want to enable.

Mode	All
<b>Remote Command</b>	:STATus:QUESTionable:PTRansition <integer>  :STATus:QUESTionable:PTRansition?
Example	STAT:QUES:PTR 16 Temperature summary 'questionable asserted' will be reported to the Status Byte Register.
Preset	32767
Min	0
Max	32767
SCPI Status Bits/OPC Dependencies	Sequential command

### Questionable Calibration Register

#### Questionable Calibration Condition

This query returns the decimal value of the sum of the bits in the Questionable Calibration Condition register.

The data in this register is continuously updated and reflects the current conditions.

Mode	All
<b>Remote Command</b>	:STATus:QUESTionable:CALibration:CONDition?
Example	STAT:QUES:CAL:COND?
Preset	0
SCPI Status Bits/OPC Dependencies	Sequential command

### Questionable Calibration Enable

This command determines which bits in the Questionable Calibration Condition Register will set bits in the Questionable Calibration Event register, which also sets the Calibration Summary bit (bit 8) in the Questionable Register. The variable <integer> is the sum of the decimal values of the bits you want to enable.

Mode	All
<b>Remote Command</b>	:STATus:QUEStionable:CALibration:ENABle <integer>  :STATus:QUEStionable:CALibration:ENABle?
Example	STAT:QUES:CAL:ENAB 16384 Can be used to query if an alignment is needed, if you have turned off the automatic alignment process.
Min	0
Max	32767
SCPI Status Bits/OPC Dependencies	Sequential command

### Questionable Calibration Event Query

This query returns the decimal value of the sum of the bits in the Questionable Calibration Event register.

---

**NOTE** The register requires that the associated PTR or NTR filters be set before a condition register bit can set a bit in the event register. The data in this register is latched until it is queried. Once queried, the register is cleared.

---

Mode	All
<b>Remote Command</b>	:STATus:QUEStionable:CALibration[:EVENT]?
Example	STAT:QUES:CAL?
Preset	0
SCPI Status Bits/OPC Dependencies	Sequential command

## Questionable Calibration Negative Transition

This command determines which bits in the Questionable Calibration Condition register will set the corresponding bit in the Questionable Calibration Event register when the condition register bit has a negative transition (1 to 0). The variable <integer> is the sum of the decimal values of the bits that you want to enable.

Mode	All
<b>Remote Command</b>	:STATus:QUESTionable:CALibration:NTRansition <integer>  :STATus:QUESTionable:CALibration:NTRansition?
Example	STAT:QUES:CAL:NTR 16384 Alignment is not required.
Preset	0
Min	0
Max	32767
SCPI Status Bits/OPC Dependencies	Sequential command

## Questionable Calibration Positive Transition

This command determines which bits in the Questionable Calibration Condition register will set the corresponding bit in the Questionable Calibration Event register when the condition register bit has a positive transition (0 to 1). The variable <integer> is the sum of the decimal values of the bits that you want to enable.

Mode	All
<b>Remote Command</b>	:STATus:QUESTionable:CALibration:PTRansition <integer>  :STATus:QUESTionable:CALibration:PTRansition? ?
Example	STAT:QUES:CAL:PTR 16384 Alignment is required.
Preset	32767
Min	0
Max	32767
SCPI Status Bits/OPC Dependencies	Sequential command

## Questionable Calibration Extended Needed Register

### Questionable Calibration Extended Needed Condition

This query returns the decimal value of the sum of the bits in the Questionable Calibration Extended Needed Condition register.

---

**NOTE** The data in this register is continuously updated and reflects the current conditions.

---

Mode	All
<b>Remote Command</b>	:STATus:QUEStionable:CALibration:EXTended:NEEDED:CONDition?
Example	STAT:QUES:CAL:EXT:NEED:COND?
Preset	0
SCPI Status Bits/OPC Dependencies	Sequential command

### Questionable Calibration Extended Needed Enable

This command determines which bits in the Questionable Calibration Extended Needed Condition Register will set bits in the Questionable Calibration Extended Needed Event register, which also sets bit 14 of the Questionable Calibration Register. The variable <integer> is the sum of the decimal values of the bits you want to enable.

Mode	All
<b>Remote Command</b>	:STATus:QUEStionable:CALibration:EXTended:NEEDED:ENABLE <integer>  :STATus:QUEStionable:CALibration:EXTended:NEEDED:ENABLE?
Example	STAT:QUES:CAL:EXT:NEED:ENAB 2 Can be used to query if an EMI conducted alignment is needed.
Preset	32767
Min	0
Max	32767
SCPI Status Bits/OPC Dependencies	Sequential command

## Questionable Calibration Extended Needed Event Query

This query returns the decimal value of the sum of the bits in the Questionable Calibration Extended Needed Event register.

---

**NOTE** The register requires that the associated PTR or NTR filters be set before a condition register bit can set a bit in the event register. The data in this register is latched until it is queried. Once queried, the register is cleared.

---

Mode	All
<b>Remote Command</b>	:STATus:QUESTionable:CALibration:EXTended:NEEDED[:EVENT]?
Example	STAT:QUES:CAL:EXT:NEED?
Preset	0
SCPI Status Bits/OPC	Sequential command
Dependencies	

## Questionable Calibration Extended Needed Negative Transition

This command determines which bits in the Questionable Calibration Extended Needed Condition register will set the corresponding bit in the Questionable Calibration Extended Needed Event register when the condition register bit has a negative transition (1 to 0). The variable <integer> is the sum of the decimal values of the bits that you want to enable.

Mode	All
<b>Remote Command</b>	:STATus:QUESTionable:CALibration:EXTended:NEEDED:NTRansition <integer> :STATus:QUESTionable:CALibration:EXTended:NEEDED:NTRansition?
Example	STAT:QUES:CAL:EXT:NEED:NTR 2 Align EMI conducted is not required.
Preset	0
Min	0
Max	32767
SCPI Status Bits/OPC	Sequential command
Dependencies	

### Questionable Calibration Extended Needed Positive Transition

This command determines which bits in the Questionable Calibration Extended Needed Condition register will set the corresponding bit in the Questionable Calibration Extended Needed Event register when the condition register bit has a positive transition (0 to 1). The variable <integer> is the sum of the decimal values of the bits that you want to enable.

Mode	All
<b>Remote Command</b>	:STATus:QUESTionable:CALibration:EXTended :NEEDed:PTRansition <integer>  :STATus:QUESTionable:CALibration:EXTended :NEEDed:PTRansition?
Example	STAT:QUES:CAL:EXT:NEED:PTR 2 Align EMI conducted is required.
Preset	32767
Min	0
Max	32767
SCPI Status Bits/OPC Dependencies	Sequential command

### Questionable Power Register

#### Questionable Power Condition

This query returns the decimal value of the sum of the bits in the Questionable Power Condition register.

---

**NOTE** The data in this register is continuously updated and reflects the current conditions.

---

Mode	All
<b>Remote Command</b>	:STATus:QUESTionable:POWer:CONDition?
Example	STAT:QUES:POW:COND?
Preset	0
SCPI Status Bits/OPC Dependencies	Sequential command

## Questionable Power Enable

This command determines which bits in the Questionable Power Condition Register will set bits in the Questionable Power Event register, which also sets the Power Summary bit (bit 3) in the Questionable Register. The variable <integer> is the sum of the decimal values of the bits you want to enable.

Mode	All
<b>Remote Command</b>	:STATus:QUESTionable:POWer:ENABle <integer>  :STATus:QUESTionable:POWer:ENABle?
Example	STAT:QUES:POW:ENAB 32 50 MHz Input Pwr too High for Cal will be reported to the Power Summary of the Status Questionable register.
Preset	32767
Min	0
Max	32767
SCPI Status Bits/OPC Dependencies	Sequential command

## Questionable Power Event Query

This query returns the decimal value of the sum of the bits in the Questionable Power Event register.

---

**NOTE** The register requires that the associated PTR or NTR filters be set before a condition register bit can set a bit in the event register. The data in this register is latched until it is queried. Once queried, the register is cleared.

---

Mode	All
<b>Remote Command</b>	:STATus:QUESTionable:POWer[:EVENT]?
Example	STAT:QUES:POW?
Preset	0
SCPI Status Bits/OPC Dependencies	Sequential command

### Questionable Power Negative Transition

This command determines which bits in the Questionable Power Condition register will set the corresponding bit in the Questionable Power Event register when the condition register bit has a negative transition (1 to 0). The variable <integer> is the sum of the decimal values of the bits that you want to enable.

Mode	All
<b>Remote Command</b>	:STATus:QUEStionable:POWer:NTRansition <integer>  :STATus:QUEStionable:POWer:NTRansition?
Example	STAT:QUES:POW:NTR 32 50 MHz Input Power became OK for Cal will be reported to the Power Summary of the Status Questionable register.
Preset	0
Min	0
Max	32767
SCPI Status Bits/OPC Dependencies	Sequential command

### Questionable Power Positive Transition

This command determines which bits in the Questionable Power Condition register will set the corresponding bit in the Questionable Power Event register when the condition register bit has a positive transition (0 to 1). The variable <integer> is the sum of the decimal values of the bits that you want to enable.

Mode	All
<b>Remote Command</b>	:STATus:QUEStionable:POWer:PTRansition <integer>  :STATus:QUEStionable:POWer:PTRansition?>
Example	STAT:QUES:POW:PTR 32 50 MHz Input Power became too high for Cal will be reported to the Power Summary of the Status Questionable register.
Preset	32767
Min	0
Max	32767
SCPI Status Bits/OPC Dependencies	Sequential command



---

# 10 Troubleshooting

The following topics can be found in this chapter:

- [“Check the Basics” on page 130](#)
- [“Problems with Microsoft Windows XP” on page 131](#)
- [“Returning the RF Preselector for Service” on page 132](#)

---

**WARNING** No operator serviceable parts inside. Refer servicing to qualified personnel. To prevent electrical shock do not remove covers.

---

## Check the Basics

- Is there power at the receptacle?
- Is the RF Preselector turned on? Check to see if the green LED beside the power switch is on. Also, listen for internal fan noise to determine if the RF Preselector cooling fans are running.
- If other equipment, cables, and connectors are being used with your RF Preselector, make sure they are connected properly and operating correctly.
- If the RF Preselector is not functioning as expected, return the RF Preselector to a known state by pressing **Preset**.
- If the RF Preselector is not communicating through the LAN connection, check for the presence of blinking yellow LEDs on the rear panel LAN connector. If the receive LED is not blinking, check the LAN cable and LAN integrity.

---

**TIP** You can get automatic electronic notification of new firmware releases and other product updates and information by subscribing to <http://agilent.com/find/notifyme>

---

## Problems with Microsoft Windows XP

The Microsoft Windows XP operating system settings have been optimized for the best performance. Modification of these settings may degrade instrument performance. Those that can be safely modified are described in Chapter 4 , “Instrument Configuration.”

The N9039A is an Open Windows environment, so you can install software on the instrument. However, installation of non-approved software may affect instrument performance. Agilent does not warrant the performance with non-approved software installed.

---

## Returning the RF Preselector for Service

### Calling Agilent Technologies

Agilent Technologies has offices around the world to provide you with complete support for your RF Preselector. To obtain servicing information or to order replacement parts, contact the nearest Agilent Technologies office listed below. In any correspondence or telephone conversations, refer to your RF Preselector by its product number, full serial number, and software revision.

Press **System**, **Show**, **System**, and the product number, serial number, and software revision information will be displayed on your RF Preselector screen. A serial number label is also attached to the rear panel of the RF Preselector.

### Locations for Agilent Technologies

Table 10-1.

**Online assistance:** <http://www.agilent.com/find/assist>

**United States**

(tel) 1 800 829 4444  
(fax) 1 800 829 4433

**Canada**

(tel) 1 877 894 4414  
(fax) (905) 282-6495

**Europe**

(tel) (31 20) 547 2323  
(fax) (31 20) 547 2390

**Latin America**

(tel) (305) 269 7500  
(fax) (305) 269 7599

**Japan**

(tel) (81) 426 56 7832  
(fax) (81) 426 56 7840

**Australia**

(tel) 1 800 629 485  
(fax) (61 3) 9210 5947

**New Zealand**

(tel) 0 800 738 378  
(fax) 64 4 495 8950

**Asia Pacific**

(tel) (852) 3197 7777  
(fax) (852) 2506 9284

### Read the Warranty

See [Warranty, on page 135](#), for information on the warranty for your RF Preselector. Please read it and become familiar with its terms.

If your RF Preselector is covered by a separate maintenance agreement, please be familiar with its terms.

### Service Options

Agilent Technologies offers several optional maintenance plans to service your RF Preselector after the warranty has expired. Call your Agilent Technologies office for full details.

If you want to service the RF Preselector yourself after the warranty expires, you can purchase the service documentation that provides all necessary test and maintenance information.

You can order the service documentation, (assembly level troubleshooting information) through your Agilent Technologies office.

## Service Tag

When you are returning the RF Preselector to Agilent Technologies for service, fill out and attach one of the blue service tags provided at the end of this chapter. Please be as specific as possible about the problem. If you have recorded any error messages that appeared on the display, have completed a functional test, or have any other specific data on the performance of your RF Preselector, please include a copy of this information. An example of the tag is shown below

**Agilent Technologies**

Should one of your instruments need repair, the service organization is ready to serve you. However, you can help us serve you more effectively. When sending an instrument to Agilent for repair, please fill out this card and attach it to the product. Increased repair efficiency and reduced turn-around time should result.

COMPANY \_\_\_\_\_

ADDRESS \_\_\_\_\_

TECHNICAL CONTACT PERSON \_\_\_\_\_

PHONE Number \_\_\_\_\_ EXT. \_\_\_\_\_

MODEL Number \_\_\_\_\_ SERIAL Number \_\_\_\_\_

MODEL Number \_\_\_\_\_ SERIAL Number \_\_\_\_\_

P.O. Number \_\_\_\_\_ DATE \_\_\_\_\_

Accessories returned with unit:

NONE  CABLE(S)

POWER CABLE  ADAPTER(S)

OTHER: \_\_\_\_\_

Service needed::

CALIBRATION ONLY

REPAIR  REPAIR & CAL

OTHER: \_\_\_\_\_

Observed Symptoms/Problems

FAILURE MODE IS:

CONSTANT  INTERMITTENT

SENSITIVE TO:

COLD  HEAT  VIBRATION

FAILURE SYMPTOMS/SPECIAL CONTROL SETTINGS: \_\_\_\_\_

\_\_\_\_\_

\_\_\_\_\_

\_\_\_\_\_

If unit is part of system, list model number(s) of Other interconnected instruments. \_\_\_\_\_

\_\_\_\_\_

\_\_\_\_\_

## Packaging the Instrument

Use original or comparable packaging. It is best to pack the unit in the original factory packaging materials if they are available.

**CAUTION** RF Preselector damage can result from using packaging materials other than those specified. Never use styrene pellets in any shape as packaging materials. They do not adequately cushion the equipment or prevent it from shifting in the carton. They cause equipment damage by generating static electricity and by lodging in the RF Preselector louvers, blocking airflow.

You can repackage the RF Preselector with commercially available materials, as follows:

1. Attach a completed service tag to the RF Preselector.
2. Wrap the RF Preselector in antistatic plastic to reduce the possibility of damage caused by electrostatic discharge.
3. Use a strong shipping container. The carton must be both large enough and strong enough to accommodate the RF Preselector. A double-walled, corrugated cardboard carton with 159 kg (350 lb) bursting strength is adequate. Allow at least 3 to 4 inches on all sides of the RF Preselector for packing material.
4. Surround the equipment with three to four inches of packing material and prevent the equipment from moving in the carton. If packing foam is not available, the best alternative is plastic bubble-pak. This material looks like a plastic sheet filled with 1-1/4 inch air bubbles. Use the pink-colored bubble which reduces static electricity. Wrapping the equipment several times in this material should both protect the equipment and prevent it from moving in the carton.
5. Seal the shipping container securely with strong nylon adhesive tape.
6. Mark the shipping container “**FRAGILE, HANDLE WITH CARE**” to assure careful handling.
7. Retain copies of all shipping papers.

---

# 11 Specifications

The complete list of Specifications for the EMI Receiver, PSA Option 239, can be found at the following Website:

<http://www.agilent.com/find/N9039A>

## Warranty

This Agilent Technologies instrument product is warranted against defects in material and workmanship for a period of one year from date of shipment. During the warranty period, Agilent Technologies will, at its option, either repair or replace products that prove to be defective.

For warranty service or repair, this product must be returned to a service facility designated by Agilent Technologies. Buyer shall prepay shipping charges to Agilent Technologies and Agilent Technologies shall pay shipping charges to return the product to Buyer. However, Buyer shall pay all shipping charges, duties, and taxes for products returned to Agilent Technologies from another country.

Agilent Technologies warrants that its software and firmware designated by Agilent Technologies for use with an instrument will execute its programming instructions when properly installed on that instrument. Agilent Technologies does not warrant that the operation of the instrument, or software, or firmware will be uninterrupted or error-free.

## Limitation of Warranty

The foregoing warranty shall not apply to defects resulting from improper or inadequate maintenance by Buyer, Buyer-supplied software or interfacing, unauthorized modification or misuse, operation outside of the environmental specifications for the product, or improper site preparation or maintenance.

NO OTHER WARRANTY IS EXPRESSED OR IMPLIED. AGILENT TECHNOLOGIES SPECIFICALLY DISCLAIMS THE IMPLIED WARRANTIES OF MERCHANTABILITY AND FITNESS FOR A PARTICULAR PURPOSE.

Specifications  
**N9039A RF Preselector Specifications**

---

## N9039A RF Preselector Specifications

Description	Specifications	Supplemental Information
Calibration Cycle	1 year	

Description	Specifications	Supplemental Information
<b>Model and Option listings</b> <b>RF IN / OUT</b> <i>Option BAB</i>		Type N Connector APC 3.5 Connector



Description	Range	Specifications
<b>Pre-selection Filters</b>	9 to 150 kHz	<b>-6 dB bandwidth (nominal)</b> 284 kHz, fixed lowpass
	150 kHz to 1 MHz	1.5 MHz, fixed bandpass
	1 to 2 MHz	2.5 MHz, fixed bandpass
	2 to 5 MHz	6.9 MHz, fixed bandpass
	5 to 8 MHz	9.0 MHz, fixed bandpass
	8 to 11 MHz	9.2 MHz, fixed bandpass
	11 to 14 MHz	8.9 MHz, fixed bandpass
	14 to 17 MHz	9.2 MHz, fixed bandpass
	17 to 20 MHz	8.7 MHz, fixed bandpass
	20 to 24 MHz	9.0 MHz, fixed bandpass
	24 to 28 MHz	8.8 MHz, fixed bandpass
	28 to 32 MHz	8.8 MHz, fixed bandpass
	28 to 55 MHz	5.1 MHz, tracking bandpass
	55 to 100 MHz	6.5 MHz, tracking bandpass
	100 to 155 MHz	10 MHz, tracking bandpass
	155 to 235 MHz	16.8 MHz, tracking bandpass
235 to 350 MHz	22.5 MHz, tracking bandpass	
350 to 470 MHz	41 MHz, tracking bandpass	
470 to 620 MHz	64 MHz, tracking bandpass	
620 to 820 MHz	49 MHz, tracking bandpass	
820 to 1 GHz	69 MHz, tracking bandpass	

Specifications  
**N9039A RF Preselector Specifications**

Description	Specifications	Supplemental Information
<b>Inputs and Outputs</b>		
<b>Front Panel</b>		
RF IN	Type N	female (Standard)
	APC 3.5	male (Option BAB)
RF OUT	Type N	female (Standard)
	APC 3.5	male (Option BAB)
CAL SOURCE IN	Type N	female
USB 2.0 Ports		female
Master (2 ports)		
Connector	USB Type "A"	
Output Current		0.5 A (nominal)
<b>Rear Panel</b>		
EXTERNAL TRIGGER OUT	BNC	female
PULSE TRIGGER 2 OUT	BNC	female
Monitor Out		
Connector	VGA compatible, 15-pin mini D-SUB	
Format		XGA (60 Hz vertical sync rates, non-interlaced) Analog RGB
Resolution	1024 x 768	
USB 2.0 Ports		
Master (4 ports)		
Connector	USB Type "A"	female
Output Current		0.5 A (nominal)
Slave (1 port)		
Connector	USB Type "B"	female
Output Current		0.5 A (nominal)
GPIB Interface		
Connector	IEEE-488 bus connector	

Description	Specifications	Supplemental Information
GPIB Codes		SH1, AH1, T6, SR1, RL1, PP0, DC1, C1,C2, C3 and C28, DT1, L4, C0
LAN TCP/IP Interface	RJ45 Ethertwist	100BaseT

Description	Specifications	Supplemental Information
<b>Temperature Range</b>		
Operating	5 to 50 °C	
Storage	-40 to 70 °C	
<b>Altitude</b>	4600 meters (approx. 15,000 feet)	

Description	Specifications	Supplemental Information
<b>Environmental and Military Specifications</b>		Samples of this product have been type tested in accordance with the Agilent Environmental Test Manual and verified to be robust against the environmental stresses of Storage, Transportation and End-use; those stresses include but are not limited to temperature, humidity, shock, vibration, altitude and power line conditions. Test Methods are aligned with IEC 60068-2 and levels are similar to MIL-PRF-28800F Class 3

Specifications  
**N9039A RF Preselector Specifications**

Description	Specification
<b>EMC</b>	Complies with European EMC Directive 89/336/EEC, amended by 93/68/EEC <ul style="list-style-type: none"> <li>— IEC/EN 61326</li> <li>— CISPR Pub 11 Group 1, Class B</li> <li>— AS/NZS CISPR 11:2002</li> <li>— ICES/NMB-001</li> </ul>

Acoustic Noise Emission/Geraeuschemission <sup>a</sup>	
LpA <65 dB	LpA <60 dB
Operator position	Am Arbeitsplatz
Normal position	Normaler Betrieb
Per ISO 7779	Nach DIN 45635 t.19

- a. The Agilent N9039A meets the Agilent Quiet office/lab/test space sound pressure and sound power specification when ventilation input temperature is below +28 degrees C. It complies with German Acoustic regulations:

Acoustic noise emission Geraeuschemission

Description	Specification
<b>Safety</b>	Complies with European Low Voltage Directive 73/23/EEC, amended by 93/68/EEC <ul style="list-style-type: none"> <li>— IEC/EN 61010-1</li> <li>— Canada: CSA C22.2 No. 61010-1</li> <li>— USA: UL 61010-1</li> </ul>

Description	Specification	Supplemental Information
<b>Power Requirements</b>		
Voltage (low range)	100/120 V	
Frequency	50/60 Hz	
Voltage (high range)	220/240 V	
Frequency	50/60 Hz	
Power Consumption, On	<90 W	
Power Consumption, Standby	<30 W	

Description	Specifications	Supplemental Information
<b>Dimensions</b>		
Height	177 mm (7.0 in)	Without feet (add 15 mm with feet)
Width	425 mm (16.7 in)	Without side handles (add 12 mm with handles)
Length	551 mm (21.7 in)	

Description	Specifications	Supplemental Information
<b>Weight</b>		
Net		18 kg (40 lbs)
Shipping		21 kg (46 lbs)

Description	Specifications	Supplemental Information
<b>Displays</b>		
Resolution	1024 x 768	XGA
Size		213 mm (8.4 in) diagonal (nominal)

Specifications  
**N9039A RF Preselector Specifications**

## Symbols

\*CLS, 108  
\*ESE, 117, 118  
\*ESR?, 117  
\*SRE, 114  
\*STB?, 114  
.NET, 46

## A

ac power cord, 18  
add  
    a network connection, 44  
    a printer, 45  
Adobe Acrobat Reader, 46  
Agilent directories and files, 46  
Agilent I/O Libraries, 46  
Agilent Recovery System, 57  
Agilent Technologies, calling, 132  
Agilent-Only user accounts, 46  
alignments menu softkeys  
    restore align data, 87  
    show alignment statistics, 86  
annotations, display, 33  
anti virus programs, 44  
anti-virus software, 53  
Auto-hide Taskbar, 76  
automatic updates, 50, 52  
Automatic Updates, Microsoft Windows, 44

## B

battery information, 26  
blue repair tag, 133  
boot wait time, 59

## C

C drive usage, 56  
calibration  
    monitoring status of, 118  
    needed condition register, 124, 126  
calibration condition register, 121, 123  
calibration needed condition register, 124, 125  
changing  
    Windows system settings, 44  
classic Windows display, 45  
clear status, IEEE command, 102  
clock, battery, 26  
command complete, 104  
Computer Name, 65  
computer name  
    how to locate it, 68  
condition of instrument, 108  
condition register, 108  
configuring the system, 22  
connectivity

tools, 16  
connectors, front panel, 30  
Control Panel  
    taskbar, 76  
Control Panel access, 47  
Control Panel settings that can be changed, 44  
controlling Windows without a mouse, 23

## D

D drive data storage, 56  
data storage, 56  
date and time setting, 45  
defragmenting your disk, 54  
desktop saving, 73  
Device Manager settings, Microsoft Windows, 45  
Device USB port, 55  
diagnostics menu softkey  
    show hardware statistics, 94  
directories, Agilent, 46  
disk defragmentation, 54  
disk drive partitioning, 46  
display annotations, 33  
display print, 73  
display save, 73  
Display settings, Microsoft Windows, 45  
Domain Name, 65  
drive C use, 56  
drive D use, 56  
drive partitioning, 46  
drive recovery, 57  
Drivers settings, Microsoft Windows, 45

## E

electrostatic discharge (ESD)  
    protecting against, 27  
Embedded Web Server  
    Help Page, 72  
    Help Tab, 72  
    SCPI Telnet Page, 71  
    SCPI Telnet Tab, 71  
    View & Modify Configuration Page, 70  
    View & Modify Configuration Tab, 70  
    Welcome Page, 69  
embedded web server, 69  
Environment Variables settings, Microsoft Windows, 45  
error  
    questionable status register, 118  
error monitoring, 105

Error Reporting settings, Microsoft Windows, 45  
errors menu softkeys  
    clear error queue, 83  
    error list, 84  
    history, 81  
    next page, 80  
    previous page, 80  
    refresh, 83  
    status, 82  
    verbose SCPI on/off, 83  
event enable register, 108  
event register, 108  
event status byte, 102  
event status enable, IEEE command, 102  
event status register  
    query and clear, 103

## F

filter  
    negative transition, 108  
    positive transition, 108  
Firefox, 69  
firewalls, 50, 51  
fixing the hard disk, 57  
font size, changing, 45  
Fonts removal, Microsoft Windows, 45  
front panel  
    connectors and keys, 30  
    display annotations, 33  
    popup menu alternative, 67  
    symbols, 36  
    virtual, 67  
front-panel keys  
    preset, 99  
    system, 79

## G

GPIB27 or GPIB28, 46  
graphic  
    system configuration, 22

## H

hard disk recovery process, 57  
hard drive recovery, 57  
hardware  
    monitoring status of, 118  
hardware status, 108  
Help  
    Embedded Web Server, 72  
help navigation without a mouse, 23  
Hibernate, Microsoft Windows, 45  
Host USB ports, 55

**I**

identity, IEEE command  
 options, query  
 model number, query, 103  
 IIS server, 46  
 initial inspection, 16  
 installing programs to drive C, 56  
 Instrument logon, 42, 43  
 instrument preset, 104  
 instrument recovery, 57  
 instrument repair tag, 133  
 instrument status, 108  
 monitoring, 105  
 monitoring status monitoring, 105  
 Internet Explorer, 69  
 IntuiLink software, 16  
 IO config menu softkeys  
 GPIB address, 88  
 query USB connection, 89  
 reset web password, 88  
 SCPI socket control port, 89  
 USB connection status, 90  
 USB packet count, 90

**K**

Keycode Commands  
 Windows, 74  
 keys, 30

**L**

LAN configuration, 48  
 loading a printer driver, 47  
 logon  
 accounts, 43  
 instrument, 42

**M**

measurement errors  
 monitoring status of, 118  
 Microsoft SQL Server Desktop  
 Engine, 46  
 Microsoft Visual J# .NET, 46  
 Microsoft Windows  
 Automatic Updates, 44  
 Display settings, 45  
 Fonts removal, 45  
 network connection Windows  
 network connection, 44  
 Power Options, 45  
 printer install and configure, 45  
 set screen saver, 45  
 set time and date, 45  
 System Properties, 45  
 Tab settings, 45  
 user accounts, 44  
 virus protection, 44

Microsoft Windows XP system  
 settings, 44  
 monitoring errors, 105  
 monitoring instrument conditions, 118  
 monitoring status, 105  
 monitoring the instru, 108  
 mouseless help system use, 23  
 mouseless Windows navigation, 23  
 moving  
 data from analyzer, 16  
 data to PC, 16  
 MSSQL\$CDF service, 46  
 My Documents location, 56

**N**

N9039A  
 Computer Name, 65  
 computer name, 68  
 Domain Name, 65  
 internet access, 69  
 popup menus, 67  
 virtual front panel, 67  
 web access, 69  
 windows system, 61  
 navigating without a mouse, 23  
 negative transition filter, 108  
 network connection, Microsoft  
 Windows, 44  
 notices, 2, 3

**O**

operating remotely, 62  
 operating system, 61  
 operation complete, IEEE command,  
 104  
 operation condition register, 120  
 options  
 query, 104  
 options, IEEE command, 104

**P**

packaging, 133  
 packaging symbol, 37  
 partitioning the hard-disk drive, 46  
 passwords, 42, 43  
 PC connectivity, 16  
 Performance settings, Microsoft  
 Windows, 45  
 positive transition filter, 108  
 power condition register, 127, 128  
 Power Options, Microsoft Windows,  
 45  
 power requirements, 18  
 preset, 104  
 print screen, 73  
 printer driver loading, 47

printer install and configure, Microsoft  
 Windows, 45  
 printer setup, 47  
 printing a window, 73  
 printing the desktop, 73  
 program storage, 56

**Q**

questionable condition register, 120,  
 121, 123  
 questionable status register, 118

**R**

rear panel  
 symbols, 36  
 rear panel features, 35  
 recovering the hard drive, 57  
 recovery process, 57  
 recovery timing, 59  
 register  
 calibration condition, 121, 123  
 calibration needed condition, 124,  
 125  
 operation condition, 120  
 power condition, 127, 128  
 questionable condition, 120, 121,  
 123  
 temperature condition, 119, 120,  
 126, 127  
 registers  
 calibration needed condition, 126  
 condition, 108  
 event, 108  
 event enable, 108  
 needed calibration condition, 124  
 service request enable, 115  
 standard event status, 116  
 registry entries, 46  
 remote commands only  
 list installed options, 96  
 lock front panel keys, 96  
 query elapsed time, 95  
 query high temperature extremes, 95  
 query low temperature extremes, 95  
 query USB connection, 89  
 SCPI socket control port, 89  
 set date, 97  
 set time, 97  
 toggle full screen, 97  
 USB connection status, 90  
 USB packet count, 90  
 Remote Desktop  
 running, 64  
 Remote Operation  
 Connection Speed, 66  
 remote operation, 62  
 embedded web server, 69



- internet access, 69
- repair tag, 133
- requirements
  - system location, 19
- reset, IEEE command, 104
- restoring your instrument, 54
- RF Preselector
  - options, 16
  - overview, 13
  - power requirements, 18
- running Windows without a mouse, 23
  
- S**
- safety notices, 3
- saving a window image, 73
- saving data to internal drives, 56
- saving programs on C drive, 56
- saving the desktop image, 73
- SCPI
  - Telnet Control, 71
- screen annotation, 33
- screen capture, 73
- screen resolution setting, Microsoft Windows, 45
- screen saver settings, Microsoft Windows, 45
- security, 50
- serial number, query, 103
- service options, 132
- service request enable register, 115
- service request, IEEE command, 105
- service requests, 112
- service tag, 133
- services running, 46
- setting
  - LAN, 48
- Shortcut keys
  - Windows, 74
- show menu softkeys
  - errors, 80
  - hardware, 85
  - system, 84
- software
  - IntuiLink, 16
- spyware, 53
- SRQ, 105
- SRQ command, 112
- standard event status, 116
  - enable register, 118
- standard event status byte, enable and read, 102
- standard event status register, IEEE command, 103
- Startup and Recovery settings, Microsoft Windows, 45
- Startup Folder
  - Windows, 77
- status byte
  - clearing, 102
  - register system, 108
- status byte, IEEE command, 105
- status enable register, 118
- status register
  - questionable status, 118
- status registers
  - setting and querying, 109
- storing data on D drive, 56
- symbols, on front and rear panels, 36
- synchronization, 104, 106
- system cables, 22
- system configuration, 22
- system key, 79
- system menu softkeys
  - alignments, 86
  - control panel, 92
  - diagnostics, 94
  - IO config, 88
  - licensing, 93
  - show, 80
- system options, 16
- System Properties, Microsoft Windows, 45
- system recovery, 57
- system restore, 54
- system settings that can be changed, 44
  
- T**
- Tab settings, Microsoft Windows, 45
- Taskbar
  - Windows, 76
- temperature condition register, 119, 120, 126, 127
- time and date setting, Microsoft Windows, 45
- timing control, 104, 106
- trademark acknowledgement, 3, 4
- trademarks, 28
- troubleshooting
  - check basics, 130
  - problems with Windows XP, 131
  
- U**
- unlocked hardware
  - monitoring status of, 118
- updates, automatic, 44
- updating Windows, 52
- URL, sales and service, 132
- USB host ports, 55
- USB Series A or B ports, 55
- User Accounts location, 56
- user accounts, Microsoft Windows, 44
- user logon, 42
- user logon accounts, 43
  
- User Profiles settings, Microsoft Windows, 45
- user startup folder, 77
- using help without a mouse, 23
- using the instrument remotely, 62
- using Windows without a mouse, 23
  
- V**
- virtual front panel, 67
- virus protection, 53
- virus protection programs, 44
  
- W**
- wait, IEEE command, 106
- warm-up time, 20
- warranty, 132
- Web Browser
  - Microsoft Internet Explorer, 69
  - Mozilla Firefox, 69
- window saving, 73
- Windows, 23
  - Automatic Updates, 44
  - Colors, 65
  - Control Panel, 76
  - Display settings, 45
  - Fonts removal, 45
  - Power Options, 45
  - print screen, 73
  - printer install and configure, 45
  - Remote Desktop
    - Installing, 63
    - Setting up, 63
  - screen capture, 73
  - set screen saver, 45
  - set time and date, 45
  - Shortcut keys, 74
  - Startup Folder, 77
  - System Properties, 45
  - Tab settings, 45
  - taskbar
    - auto-hide, 76
    - user accounts, 44
    - virus protection, 44
  - Window Size, 65
  - XP, 61
- Windows Classic Style, 45
- Windows firewall, 51
- Windows Remote Desktop, 62
  - ending session, 66
  - options, 65
  - Options Dialog
    - Display Tab, 65
    - Experience Tab, 66
    - General Tab, 65
  - popup menus, 67
  - running, 64
  - Setting up Remote Computer, 63

---

setting up the N9039A, [62](#)  
Setting up Windows Systems  
  32-bit, [63](#)  
  XP, [63](#)  
  virtual front panel, [67](#)  
windows security, [50](#)  
Windows services, [46](#)  
Windows updates, [52](#)  
Windows XP settings, [44](#)  
Windows XP Style, [45](#)  
Windows, Remote Desktop  
  ending session, [66](#)