

Agilent N432A Thermistor Power Meter

User's Guide



Agilent Technologies

Notices

© Agilent Technologies, Inc. 2010 - 2011

No part of this manual may be reproduced in any form or by any means (including electronic storage and retrieval or translation into a foreign language) without prior agreement and written consent from Agilent Technologies, Inc. as governed by United States and international copyright laws.

Manual Part Number

N432A-90002

Edition

Third Edition, October 26, 2011

Printed in Malaysia

Agilent Technologies, Inc.
5301 Stevens Creek Blvd.
Santa Clara, CA 95051 USA

Trademark Acknowledgements

Microsoft is a trademark or registered trademark of Microsoft Corporation.

Mozilla is a trademark of the Mozilla Foundation.

Java is a trademark of Sun Microsystems, Incorporated.

Warranty

The material contained in this document is provided “as is,” and is subject to being changed, without notice, in future editions. Further, to the maximum extent permitted by applicable law, Agilent disclaims all warranties, either express or implied, with regard to this manual and any information contained herein, including but not limited to the implied warranties of merchantability and fitness for a particular purpose. Agilent shall not be liable for errors or for incidental or consequential damages in connection with the furnishing, use, or performance of this document or of any information contained herein. Should Agilent and the user have a separate written agreement with warranty terms covering the material in this document that conflict with these terms, the warranty terms in the separate agreement shall control.

Technology Licenses

The hardware and/or software described in this document are furnished under a license and may be used or copied only in accordance with the terms of such license.

Restricted Rights Legend

U.S. Government Restricted Rights. Software and technical data rights granted to the federal government include only those rights customarily provided to end user customers. Agilent provides this customary commercial license in Software and technical data pursuant to FAR 12.211 (Technical Data) and 12.212 (Computer Software) and, for the Department of Defense, DFARS 252.227-7015 (Technical Data - Commercial Items) and DFARS 227.7202-3 (Rights in Commercial Computer Software or Computer Software Documentation).

Safety Notices

CAUTION

A **CAUTION** notice denotes a hazard. It calls attention to an operating procedure, practice, or the like that, if not correctly performed or adhered to, could result in damage to the product or loss of important data. Do not proceed beyond a **CAUTION** notice until the indicated conditions are fully understood and met.

WARNING

A **WARNING** notice denotes a hazard. It calls attention to an operating procedure, practice, or the like that, if not correctly performed or adhered to, could result in personal injury or death. Do not proceed beyond a **WARNING** notice until the indicated conditions are fully understood and met.

Certification

Agilent Technologies certifies that this product met its published specifications at the time of shipment. Agilent further certifies that its calibration measurements are traceable to the United States National Institute of Standards and Technology (formerly National Bureau of Standards), to the extent allowed by that organization calibration facility, and to the calibration facilities of other International Standards Organization members.

General Warranty

The material contained in this document is provided “as is,” and is subject to being changed, without notice, in future editions. Further, to the maximum extent permitted by applicable law, Agilent disclaims all warranties, either express or implied with regard to this manual and any information contained herein, including but not limited to the implied warranties of merchantability and fitness for a particular purpose. Agilent shall not be liable for errors or for incidental or consequential damages in connection with the furnishing, use, or performance of this document or any information contained herein. Should Agilent and the user have a separate written agreement with warranty terms covering the material in this document that conflict with these terms, the warranty terms in the separate agreement shall control. Duration and conditions of warranty for this product may be superseded when the product is integrated into (becomes a part of) other Agilent products. During the warranty period, Agilent will, at its option, either repair or replace products which prove to be defective. The warranty period begins on the date of delivery or on the date of installation if installed by Agilent.

Warranty Service

For warranty service or repair, this product must be returned to a service facility designated by Agilent. For products returned to Agilent for warranty service, the Buyer shall prepay shipping charges to Agilent and Agilent shall pay shipping charges to return the product to the Buyer. However, the Buyer shall pay all shipping charges, duties, and taxes for products returned to Agilent from another country.

Limitation of Warranty

The foregoing warranty shall not apply to defects resulting from improper or inadequate maintenance by the Buyer, Buyer-supplied products or interfacing, unauthorized modification or misuse, operation outside of the environmental specifications for the product, or improper site preparation or maintenance.

The design and implementation of any circuit on this product is the sole responsibility of the Buyer. Agilent does not warrant the Buyer's circuitry or malfunctions of Agilent products that result from the Buyer's circuitry. In addition, Agilent does not warrant any damage that occurs as a result of the Buyer's circuit or any defects that result from Buyer-supplied products.

To the extent allowed by local law, Agilent makes no other warranty, expressed or implied, whether written or oral with respect to this product and specifically disclaims any implied warranty or condition of merchantability, fitness for a particular purpose, or satisfactory quality.

Exclusive Remedies

To the extent allowed by local law, the remedies provided herein are the Buyer's sole and exclusive remedies. Agilent shall not be liable for any direct, indirect, special, incidental, or consequential damages (including lost profit or data), whether based on warranty, contract, tort, or any other legal theory.

Restricted Rights Legend

The Software and Documentation have been developed entirely at private expense. They are delivered and licensed as “commercial computer software” as defined in DFARS 252.227-7013 (Oct 1988), DFARS 252.211-7015 (May 1991), or DFARS 252.227-7014 (Jun 1995), as a “commercial item” as defined in FAR 2.101(a), or as “restricted computer software” as defined in FAR 52.227-19 (Jun 1987) (or any equivalent agency regulation or contract clause), whichever is applicable. You have only those rights provided for such Software and Documentation by the applicable FAR or DFARS clause or the Agilent standard software agreement for the product involved.

Technology Licenses

The hardware and/or software described in this document are furnished under a license and may be used or copied only in accordance with the terms of such license.

Safety Summary

The following general safety precautions must be observed during all phases of operation of this instrument. Failure to comply with these precautions or with specific warnings elsewhere in this manual violates safety standards of design, manufacture, and intended use of the instrument. Agilent Technologies, Inc. assumes no liability for the customer's failure to comply with these requirements.

Safety Notices

WARNING

















A **WARNING** notice denotes a hazard. It calls attention to an operating procedure, practice, or the like that, if not correctly performed or adhered to, could result in personal injury or loss of life. Do not proceed beyond a **WARNING** notice until the indicated conditions are fully understood and met.

CAUTION

A **CAUTION** notice denotes a hazard. It calls attention to an operating procedure, practice, or the like that, if not correctly performed or adhered to, could result in damage to the product or loss of important data. Do not proceed beyond a **CAUTION** notice until the indicated conditions are fully understood and met.

Safety Symbols

The following symbols on the instrument and in the documentation indicate precautions that must be taken to maintain safe operation of the instrument.

	Caution, risk of danger. The Instruction Documentation Symbol. The instrument is marked with this symbol when it is necessary for the user to refer to the instructions in the supplied documentation.		This symbol indicates the operating switch for 'Stand-by' mode. Note, this instrument is NOT isolated from the mains when the switch is pressed. To isolate the instrument, the mains coupler (mains input cord) should be removed from the power supply.
	Alternating current (AC)		Instrument protected throughout by DOUBLE INSULATION or RE-INFORCED INSULATION
	Direct current (DC)		On (Supply)
	Both direct and alternating current		Off (Supply)
	Three-phase alternating current		Caution, risk of electric shock
	Earth (ground) TERMINAL		Caution, hot surface
	PROTECTIVE CONDUCTOR TERMINAL		In position of bi-stable push control
	Frame or chassis TERMINAL		Out position of bi-stable push control
	Equipotentiality		

General Safety Information

This is a Safety Class I instrument (provided with a protective earthing ground, incorporated in the power cord). The mains plug shall only be inserted in a socket outlet provided with a protective earth contact. Any interruption of the protective conductor inside or outside of the instrument is likely to damage the instrument. Intentional interruption is prohibited.

WARNING

- **Do not operate the instrument in an explosive atmosphere or in the presence of flammable gasses or fumes.**
 - **Do not use repaired fuses or short-circuited fuseholders. For continued protection against fire, replace the line fuse(s) only with fuse(s) of the same voltage and current rating and type.**
 - **Do not perform procedures involving cover or shield removal unless you are qualified to do so. Operating personnel must not remove the meter covers or shields. Procedures involving the removal of covers and shields are for use by service-trained personnel only.**
 - **Do not service or adjust alone. Under certain conditions, dangerous voltages may exist even with the instrument switched off. To avoid electrical shock, service personnel must not attempt internal service or adjustment unless another person, capable of rendering first aid and resuscitation, is present.**
 - **Do not operate damaged instrument. Whenever it is possible that the safety protection features built into this instrument have been impaired, either through physical damage, excessive moisture, or any other reason, REMOVE POWER and do not use the instrument until safe operation can be verified by service-trained personnel. If necessary, return the instrument to Agilent for service and repair to ensure the safety features are maintained.**
 - **Do not substitute parts or modify the instrument. Because of the danger of introducing additional hazards, do not install substitute parts or perform any unauthorized modification to the instrument. Return the instrument to Agilent for service and repair to ensure the safety features are maintained.**
-

In This Guide...

1 Introduction

This chapter introduces you to the front panel display and instrument Web browser of the Agilent N432A Thermistor Power Meter.

2 Operating Information

This chapter provides the information on the N432A general operation.

3 Maintenance

This chapter describes the built-in self-tests, error messages, and general maintenance.

4 Specifications and Characteristics

This chapter lists the specifications and characteristics of the N432A.

Declaration of Conformity (DoC)

The Declaration of Conformity (DoC) for this instrument is available on the Agilent Web site. You can search the DoC by its product model or description at the Web address below.

<http://regulations.corporate.agilent.com/DoC/search.htm>

NOTE

If you are unable to search for the respective DoC, please contact your local Agilent representative.

Contents

1 Introduction	1
LXI Class-C Compliant N432A	2
Sensor Compatibility	3
Conventions Used in This Guide	4
Front Panel Outlook	5
Rear Panel Connections	10
Display Layout	11
Window Symbols and Pop-Ups	15
Warning symbol pop-up	15
Wait symbol pop-up	16
Confirm symbol pop-up	16
Numeric entry pop-up	16
Text entry pop-up	17
List pop-up	17
Using the N432A Web Interface	18
Using the remote front panel	22
Editing the N432A LAN settings	23
Capturing the screen image	25
Getting the instrument data	26
Making the Socket Connection	27
2 Operating Information	29
Setting the Bridge Resistance	30
Setting the Resistance Type	31
Setting the Measurement Unit	34
Setting the Measurement Frequency	35

Setting the Resolution	37
Displaying Voltage Measurements	38
Making Relative Measurements	39
Setting Offsets	41
Setting the channel offset	42
Setting the display offset	43
Setting the frequency-dependent offset	45
Setting the Voltage Averaging	52
Step Detection	53
Setting Measurement Limits	54
Checking for limit failures	56
Single Function Measurement	57
Combined Measurement	58
Max Hold/Min Hold	60
Recorder Output	63
Saving and Recalling N432A States	66
Editing a register name	67
Recalling a measurement setup	67
Zeroing the N432A	69
Using the Calibration/Correction Factors	70
Frequency-specific calibration factors	70
Sensor calibration tables	71
Selecting a sensor calibration table	71
Editing/generating sensor calibration tables	73
Power Measurement Procedures	77
Internal power measurement	77
Precision power measurement	79
Voltage Standing Wave Ratio (VSWR) Measurement	82

Blank Screen 88
Secure Blank 89
Backlight Intensity Control 92
Memory Erase/Secure Erase 93
Warm Start 95

3 Maintenance 97

Self-Test 98
 Front panel selection of self-tests 98
 Instrument self-test 99
 Remote testing 101
 Test descriptions 101
Error Messages 103
 Introduction 103
 Error list 105
Operator Maintenance 112
 Checking the power line fuses 112
Contacting Agilent Technologies 113
 Prior to contacting Agilent Technologies 113
 Check the basics 114
 Instrument serial numbers 114
 Recommended calibration interval 115
Erasing Memory Data 116
Returning the N432A for Service 117
 Packaging the N432A for shipment 117
Agilent Sales and Service Offices 118

4 Specifications and Characteristics 119

Introduction 120

- Specification definitions [120](#)
- N432A Specifications [122](#)
- Rear Panel Input and Output Connections [124](#)
 - Line power [124](#)
- 1 mW Power Reference [125](#)
- Environmental Conditions [126](#)
 - General [126](#)
 - Operating environment [126](#)
 - Storage [126](#)
- Physical Characteristics [127](#)
 - Dimensions [127](#)
 - Weight [127](#)
- Regulatory Information [128](#)
 - Electromagnetic (EM) compatibility [128](#)
 - Product safety [128](#)
 - Low voltage directive [129](#)

List of Figures

- Figure 1-1 Dual numeric display 11
- Figure 1-2 Single numeric and analog display 12
- Figure 1-3 Full screen numeric display 13
- Figure 1-4 Accessing the N432A Web interface from the Connection Expert 18
- Figure 1-5 N432A Web interface (Welcome page) 19
- Figure 1-6 Blinking message to identify the N432A 20
- Figure 1-7 Example of the Lan Status message 20
- Figure 1-8 Virtual front panel 22
- Figure 1-9 Viewing the current LAN configuration from the Web interface 23
- Figure 1-10 Enter Password dialog box 23
- Figure 1-11 Changing the N432A LAN interface configuration 24
- Figure 1-12 Screen capture 25
- Figure 1-13 Obtaining instrument data 26
- Figure 1-14 Add Instrument dialog 27
- Figure 1-15 Add LAN Instruments dialog 28
- Figure 1-16 N432A connected via the socket connection 28
- Figure 2-1 Bridge resistance pop-up list 30
- Figure 2-2 Connections for Ruser measurement 31
- Figure 2-3 Resistance type pop-up list 32
- Figure 2-4 Ruser pop-up 32
- Figure 2-5 Frequency pop-up 36
- Figure 2-6 Voltage measurement display 38
- Figure 2-7 Typical relative measurement display 39
- Figure 2-8 Simplified measurement path 41
- Figure 2-9 Setting the channel offset 42
- Figure 2-10 Offset indicator 43
- Figure 2-11 Setting the display offset 44
- Figure 2-12 Frequency-dependent offset tables 46
- Figure 2-13 Frequency-dependent offset table indicator 46
- Figure 2-14 Edit Offset display with data added 48
- Figure 2-15 Edit table name pop-up 48
- Figure 2-16 Setting the offset unit 49
- Figure 2-17 Offset display in the engineering unit (when the selected unit is %) 51
- Figure 2-18 Volt Avg pop-up list 52
- Figure 2-19 Minimum limit pop-up 55

- Figure 2-20 Meter minimum pop-up 55
- Figure 2-21 Limit failures 56
- Figure 2-22 Single function measurement configuration 57
- Figure 2-23 Function pop-up list 57
- Figure 2-24 Combined measurement configuration 58
- Figure 2-25 Measurement display example 59
- Figure 2-26 Max hold/min hold measurement performed on the 'HOLD' block 60
- Figure 2-27 Hold pop-up list 61
- Figure 2-28 Min Hold and Max Hold measurement modes indicated on the display 61
- Figure 2-29 Min Hold indicated in full in the expanded window 62
- Figure 2-30 Recorder output pop-up list 63
- Figure 2-31 Recorder Minimum pop-up 64
- Figure 2-32 Recorder Maximum pop-up 64
- Figure 2-33 Save/Recall screen 66
- Figure 2-34 Save confirmation pop-up dialog 66
- Figure 2-35 File name pop-up 67
- Figure 2-36 Recall confirmation pop-up dialog 68
- Figure 2-37 Zeroing pop-up message 69
- Figure 2-38 Cal Factor pop-up 70
- Figure 2-39 Sensor table selected 72
- Figure 2-40 Sensor calibration table indicator 72
- Figure 2-41 Sensor Tbls screen 74
- Figure 2-42 Edit Cal display 75
- Figure 2-43 Edit table title pop-up 75
- Figure 2-44 Connection diagram for precision power measurement 80
- Figure 2-45 Connection diagram for VRC measurement 84
- Figure 2-46 Connection diagram for VSWR measurement 86
- Figure 2-47 Blank Screen feature 88
- Figure 2-48 Secure Blank feature 89
- Figure 2-49 Enter 6-digit Password pop-up 89
- Figure 2-50 Warning message 90
- Figure 2-51 Reconfirm Password pop-up 90
- Figure 2-52 Warning message 90
- Figure 2-53 Password reconfirmation pop-up 91
- Figure 2-54 Password required to restore display 91
- Figure 2-55 Backlight intensity control feature 92
- Figure 2-56 Increase or decrease the backlight brightness 92

- Figure 2-57 Activate memory erase using combo keys 93
- Figure 2-58 Secure Erase feature 94
- Figure 2-59 Confirmation to begin secure erase 94
- Figure 2-60 Warning message displaying the secure erase status 94
- Figure 2-61 Warm start On/Off feature 95
- Figure 3-1 Self-test completed 99
- Figure 3-2 V_{RF} , V_{COMP} , and V_0 tests skipped 100
- Figure 3-3 Error indicator 103
- Figure 3-4 Checking the fuses 112
- Figure 3-5 Secure erase status pop-up 116

List of Tables

Table 1-1	Lan Status messages	21
Table 2-1	Measurement units	34
Table 2-2	Range of values for window limits	54
Table 2-3	Ranges of the recorder output setting	65
Table 2-4	Installed thermistor sensor models	74



1 Introduction

LXI Class-C Compliant N432A	2
Sensor Compatibility	3
Conventions Used in This Guide	4
Front Panel Outlook	5
Rear Panel Connections	10
Display Layout	11
Window Symbols and Pop-Ups	15
Using the N432A Web Interface	18
Making the Socket Connection	27

This chapter provides a general overview of the N432A thermistor power meter.



LXI Class-C Compliant N432A

The N432A is a single-channel, average RF power measurement meter that supports thermistor sensors. The N432A has the capability to measure and display average power, RF bridge voltages (V_{RF0} and V_{RF1}), compensation bridge voltages (V_{COMP0} and V_{COMP1}), V_0 , and V_1 . It is also provided with a set of features such as zeroing and a built-in self-test.



Developed using LXI technology, the N432A is an LXI Class-C compliant instrument. LXI, an acronym for LAN eXtension for Instrumentation, is an instrument standard for devices that use the Ethernet (LAN) as their primary communication interface.

The N432A basic configuration consists of two key sections; bridge and meter logic. When a compatible thermistor sensor is connected to the N432A, the RF and compensation bridge circuits are formed in the bridge section. V_{RF} , which is the voltage at the top of the RF bridge, is responsive to both input RF power and ambient temperature changes. On the other hand, V_{COMP} , which is the voltage at the top of the compensation bridge, is responsive only to ambient temperature changes. The V_{RF} and V_{COMP} values are used in calculating the RF power. Meanwhile, the meter logic section processes V_{RF} and V_{COMP} to produce a meter current proportional to RF power.

In general, the N432A is an easy-to-use instrument especially with the availability of an integrated Web browser that provides a convenient way to view and modify the instrument network configuration.

Besides the LAN interface, the N432A also supports industry standard GPIB and USB interfaces for measurement automation.

Sensor Compatibility

The N432A is compatible with the Agilent 478A and 8478B thermistor sensors. The following table lists the frequency range and operating resistance for each of these thermistor sensors:

Thermistor sensor model	Frequency range (GHz)	Operating resistance (Ω)
478A	0.01 to 10	200
478A Option H63	0.0001 to 1	200
478A Option H75	0.001 to 1	200
478A Option H76	0.001 to 1	200
8478B	0.01 to 18	200

NOTE

For further information on the thermistor sensors, refer to their respective manuals.

Conventions Used in This Guide

The following conventions are used throughout this guide.





	This symbol and text represents a labeled key on the N432A front panel
Softkey	This symbol and text represents a labeled softkey, and is used to indicate that you should press the unmarked key beside the displayed text
Message	This text represents a displayed message
Parameter	This is used to represent a parameter, value, or title

Front Panel Outlook

This section briefly describes the functions of the front panel keys and connectors.



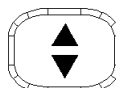
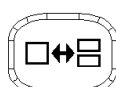



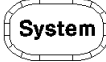

These keys are located to the left of the display.

Key	Function
	Press this key to preset the N432A to its default state
	Press this key to control the N432A from the front panel when it is operating via the remote interfaces (when Local Lock Out is disabled)
	Press this key to select the upper or lower measurement window. The selected window is highlighted by a blue line on the right of the window. Any measurement setup you create is performed in the selected window.
	Press this key to select a windowed, expanded, or full-screen display of a numeric measurement
	Press this key to switch the N432A between on and standby. When power is supplied, the background LED turns red. Pressing the key switches on the N432A and the background LED turns yellow. When the N432A is powered on, the startup will take approximately 25 seconds.

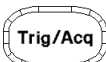

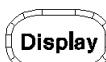
These keys are located along the lower edge of the display.

Key	Function
 System	Press this key to access general configuration menus, such as the remote interface configuration. You can also access some measurement configuration menus. The measurement screen remains visible.
 Channel	Press this key to access the channel configuration menu. Channel parameters such as voltage averaging and offsets are configured from this menu.
 Trig/Acq	Press this key to access the triggering menu
 Meas	Press this key to configure measurements for the selected measurement window, such as display offsets and relative measurements
 Display	Press this key to access the measurement display menu. You can select the displayed measurement resolution, unit, and display format. Use this key together with  Meas to configure measurement displays.

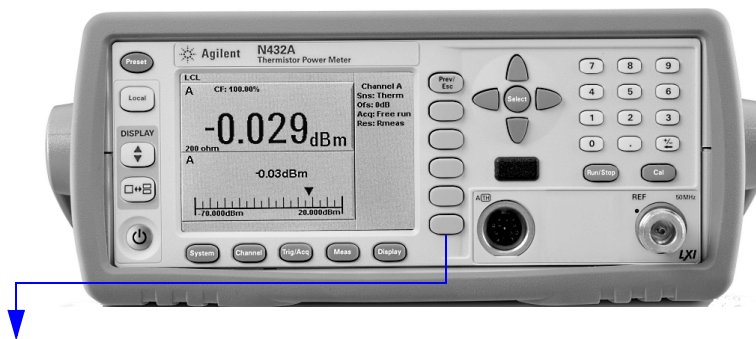



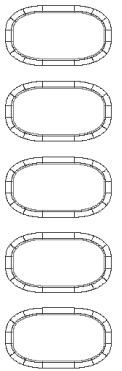
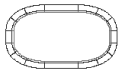

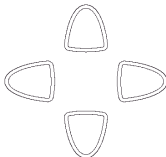

These keys are associated with the menu labels and data entry. They are located to the right of the display.

Key	Function
	Press this key to return to the previous screen. This key also cancels pop-up entries.
	<p>These unmarked keys are called 'softkeys' and are referred to by the text on the display next to them.</p> <p>For example, during a preset, you are given an option to confirm the command. Press Confirm to continue, that is, press the softkey beside the displayed word Confirm.</p>
	The lowest of the unmarked softkeys is used when there is a two-page menu to be displayed. For example, a 1 of 2 is displayed beside the key indicating the first page of a two-page menu. Press the key to access the next page or the second page (a 2 of 2 is displayed).

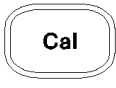

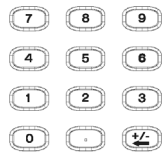
These keys and connectors are associated with the measurement channel and are located on the right of the front panel.

Key	Function
	The arrow keys are used for navigation around the parameter entry screens. The up and down arrows are used for selecting values from a pop-up list. They are also used to enter text such as table names.
	Press this key to select a highlighted field to allow data entry, select a check box, or confirm the entry of a pop-up list
	Press this key to access the zeroing menu
	Press this key to reset the MAX HOLD and MIN HOLD measurements
	Press these keys to enter numeric values in the pop-up fields, for example, the offset values. To complete the entry, use the softkey.

Connector	Function
 <p>A close-up photograph of a silver metal connector. The top left corner has the text 'REF' and the top right corner has '50 MHz'. The bottom right corner has 'LXI'. A small yellow LED is visible on the left side of the connector's face.</p>	<p>The power reference is a 1 mW (0 dBm), 50 MHz signal available from a 50 Ω type-N connector. It is used for calibrating a 478A or 8478B thermistor sensor and meter system. The yellow LED beside the connector is lit when turned on.</p>
 <p>A close-up photograph of a silver metal connector. The top left corner has the text 'A(TH)'. The connector face is dark, likely due to the thermistor sensor being mounted inside.</p>	<p>Thermistor mount input connector for 1.5 m, 3 m, and 6.1 m cables that connect to the 478A or 8478B thermistor sensors</p>

Rear Panel Connections

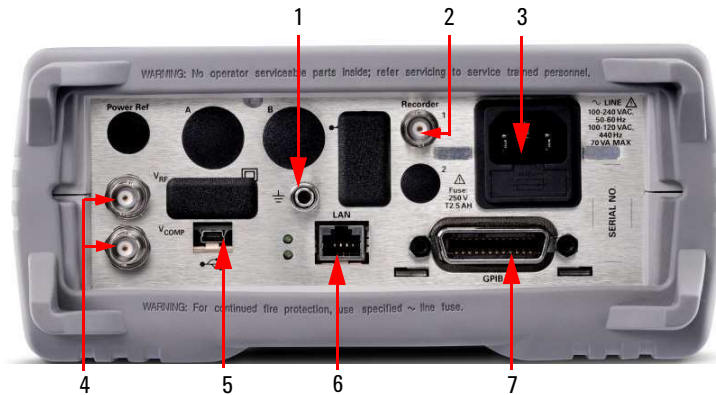

No.	Connection
1	Ground connector
2	Recorder output terminal 1 Recorder output connection is made via a BNC connector. This output produces a DC voltage that corresponds to the power level of the channel input.
3	AC inlet The N432A has an autoconfiguring power supply. This allows it to operate over a range of voltages without manually being set to a certain voltage.
4	V_{RF} and V_{COMP} output terminals The V_{RF} BNC terminal outputs the RF bridge voltage, while the V_{COMP} BNC terminal outputs the compensation bridge voltage. Both the V_{RF} and V_{COMP} outputs are used for calibrating the N432A and for precision power measurements.
5	USB Mini-B port Allows the N432A to be controlled remotely over the USB interface
6	LAN interface Allows the N432A to be controlled remotely over the LAN interface
7	GPIB interface Allows the N432A to be controlled remotely over the General Purpose Interface Bus (IEEE-488) standard interface

Display Layout

The following figure shows the display when two windows are configured in the dual numeric mode.

Other display formats are available by pressing  > **Disp Type**.

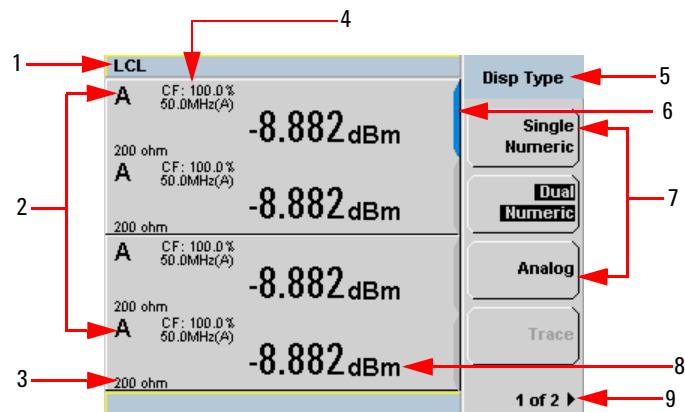

Figure 1-1 Dual numeric display

- 1 The status reporting line displays messages and the control status of the N432A.

For example, the status can be either **RMT** (remote, GPIB, USB, or LAN operation) or **LCL** (local, front panel operation). The message field will indicate **ERR** for any error conditions that occur.

- 2 The measured channel is shown with a thermistor sensor connected.
- 3 This field displays the current bridge resistance value as an indicator with or without the thermistor sensor connected.
- 4 The information in this field is displayed in two lines and depends on the sensor calibration factor, sensor calibration and frequency-dependent offset tables currently selected, and the measurement frequency.
- 5 This field displays the menu title.

For example, **Channel Setup**, or press  and the **Zero/Cal** menu is displayed.

- 6 The blue highlight on the right of the window indicates the currently selected measurement display line. This measurement line refers to the upper window/upper measurement.
- 7 The available softkey labels are displayed in these fields. Additionally, settings associated with the labeled function are displayed under the label. Softkey labels that are grayed out cannot be selected.
- 8 This displays the measurement unit.
- 9 This displays the number of pages in the current menu. For example, **1 of 2** indicates that there are two pages in the menu and the first page is currently displayed. Pressing the softkey displays the next page, indicated by **2 of 2** (press the softkey again to display the previous menu page).

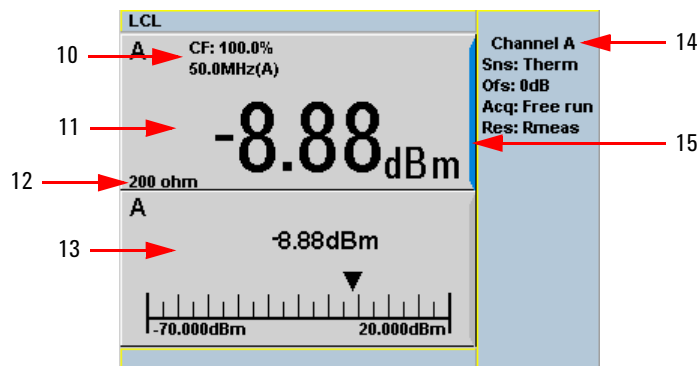



Figure 1-2 Single numeric and analog display

Figure 1-2 shows the default display format of two measurement windows in the single numeric and analog mode.

- 10 The information in this field is displayed in two lines and depends on the sensor calibration factor, sensor calibration and frequency-dependent offset tables currently selected, and the measurement frequency.
- 11 The upper window is configured to show a single numeric display.
- 12 This field displays the current bridge resistance value as an indicator with or without the thermistor sensor connected.
- 13 The lower window is configured to show an analog meter which displays the measurement result and the meter scaling.

14 This displays the connected sensor, offset value, acquisition mode, and bridge resistance type for the channel.

15 The blue highlight on the right of the window indicates the currently selected measurement display line.

Using the up/down arrow key or , you can change the measurement window selection.

Using  on a numeric measurement result window allows you to select either a single enlarged window or a full screen display. The display style is applied to the currently selected window or measurement line.

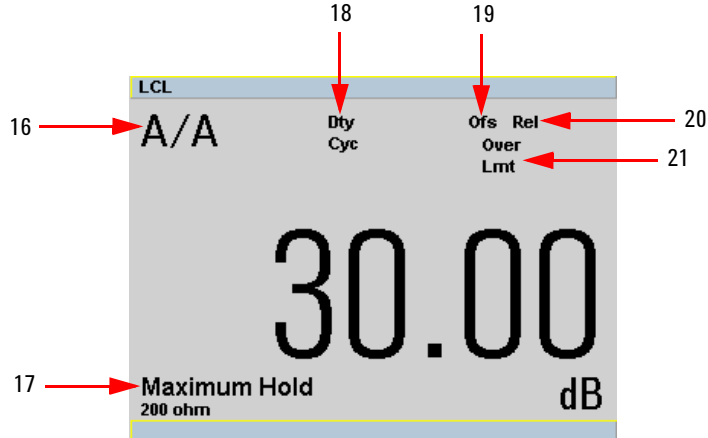

Figure 1-3 Full screen numeric display

Figure 1-3 shows a single numeric full screen displaying a relative result.

16 This field displays either a ratio or difference measurement indicator when the Combined measurement function is enabled.

17 This field displays either **Minimum Hold** or **Maximum Hold** if the range hold is set to minimum or maximum respectively.

18 This field displays **Dty Cyc** if a duty cycle is set.

19 This field displays **Ofs** if an offset is set.

20 This field displays **Rel** if relative mode is enabled.

21 This field indicates that the measurement result is beyond the configured upper or lower limit. If the measurement result is within the limits, this field is empty. If the measurement result is less than the minimum limit set, **Undr Lmt** is displayed. If the measurement result is more than the maximum limit set, **Over Lmt** is displayed.

Window Symbols and Pop-Ups

There are several different graphic symbols and pop-up messages that can occur on the N432A display. These can occur for a variety of reasons, such as:

- An error or warning occurs
- You are required to wait while the N432A carries out a procedure
- You are required to select an entry from a list
- You are required to enter a numeric value

There are three different colors used to signify the pop-up status:

- Green – used to allow data entry
- Orange – used to display information
- Red – used to display an error

Warning symbol pop-up

A warning symbol is displayed either in a pop-up message or directly in the measurement window when such an event occurs. A pop-up message is displayed for approximately two seconds. The text in the pop-up message gives details of the warning type, for example, to indicate that a sensor has insufficient bandwidth or a previously entered frequency value in a table. Depending on the severity of the warning, the pop-up may be displayed in orange or red.



Wait symbol pop-up

The wait symbol is displayed when the N432A is carrying out a procedure and no action is required from you. The symbol appears in a pop-up message, for example, during zeroing.

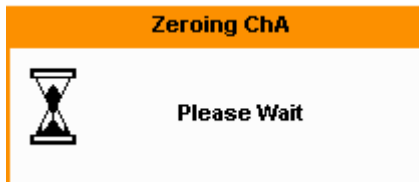

Confirm symbol pop-up

This type of pop-up message is displayed when you are required to press **Confirm** to verify your previous selection, for example, prior to a **Save** being carried out.



Numeric entry pop-up

This type of pop-up dialog is displayed when you need to modify numeric data. Use the numeric keys to enter the value.

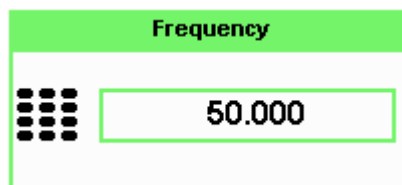

Text entry pop-up

This type of pop-up dialog is displayed when you need to modify alphanumeric data such as table names. The up/down arrow key increments/decrements the alphanumeric digit that the cursor is currently positioned. The left/right arrow key moves the cursor to another alphanumeric digit.

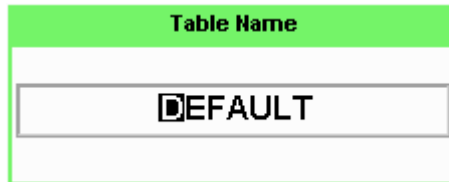

List pop-up

This pop-up list is displayed when you are required to select an entry from a list. Use the up/down arrow key to highlight your selection. Press



to complete the entry.



Using the N432A Web Interface

You can communicate with the N432A using the Web interface.

The N432A Web interface can be accessed from the Agilent Connection Expert as shown in [Figure 1-4](#).

NOTE

For more details on remote interface configuration, refer to the *N432A Thermistor Power Meter Installation Guide*.

Alternatively, the Web interface can also be accessed directly from a Web browser by entering the N432A IP address or host name in the Address panel of the browser.

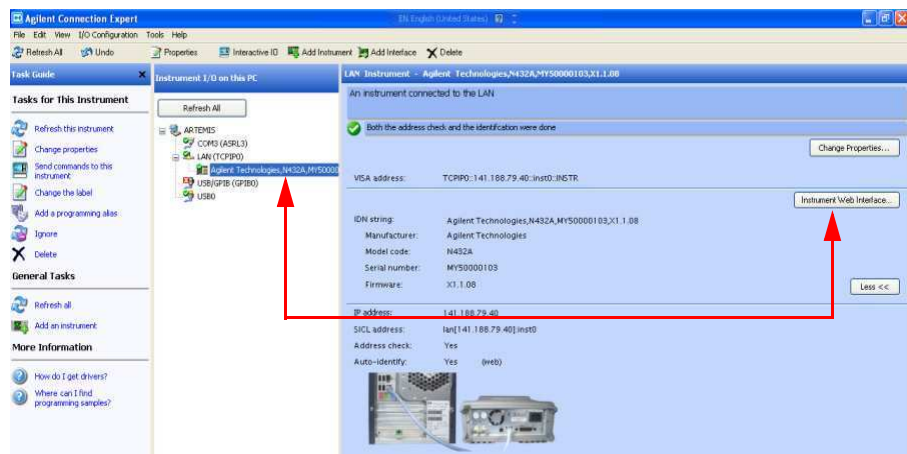

Figure 1-4 Accessing the N432A Web interface from the Connection Expert

The Welcome page of the N432A Web interface is shown as follows:

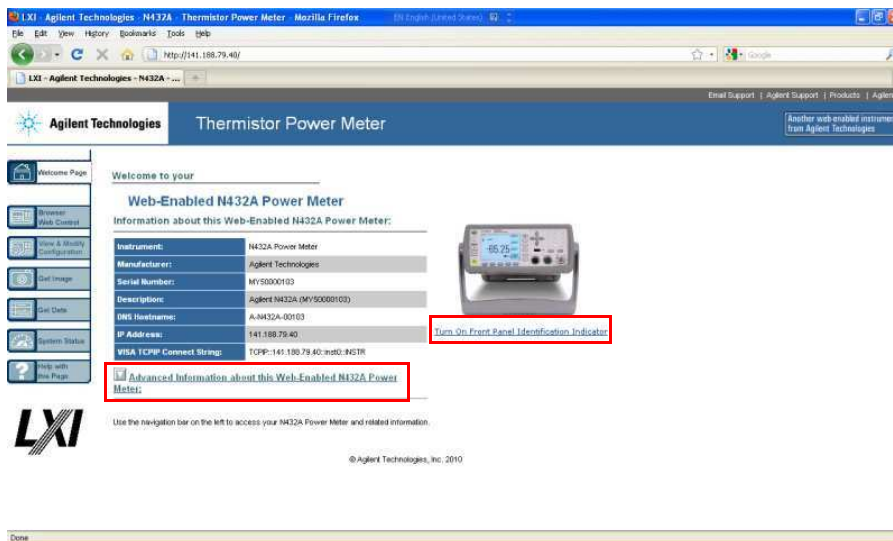

Figure 1-5 N432A Web interface (Welcome page)

You can control the N432A via GPIB, LAN, or USB connection. Connection parameters such as SCPI TCPIP socket port (5025), SCPI Telnet port (5024), VISA TCPIP Connect String, VISA USB Connect String, and GPIB address are shown on the Welcome Page. Click **Advanced Information...** to display more information on the N432A.

NOTE

- The N432A has an embedded Web server, which is listening on port 80 to serve Web pages.
- The Web pages can be browsed using Web browsers such as Internet Explorer[®] and Mozilla[®] Firefox[®].
- To obtain optimum accuracy of the N432A in a remote interface environment, it is recommended to use the LAN interface to minimize ground noise contribution.

The N432A on the network can be physically identified from the blinking message on the front panel screen by clicking **Turn On Front Panel Identification Indicator** on the Welcome Page.

When the front panel identification indicator is turned on, a blinking “IDENTIFY” message is displayed on the front panel screen as shown in the following figure. The “IDENTIFY” message will blink to identify the N432A until you click **Turn Off Front Panel Identification Indicator**.

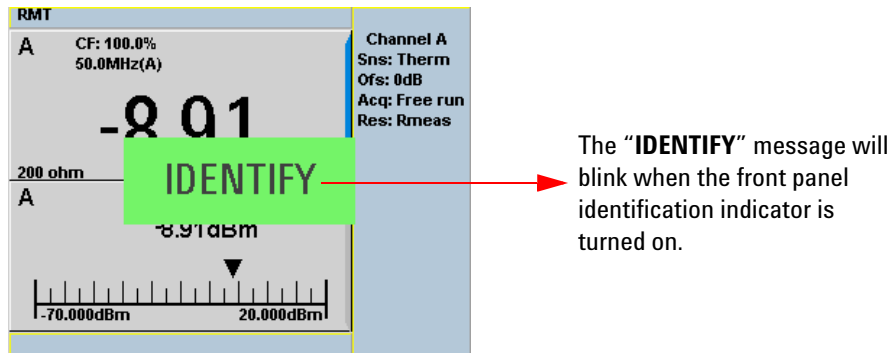

Figure 1-6 Blinking message to identify the N432A

When the N432A is configured to LAN, the **Lan Status** on the **Remote Interfaces** screen will display the LAN error condition and status of the LAN configuration connection. There are six types of **Lan Status** messages that may occur, as listed in [Table 1-1](#).

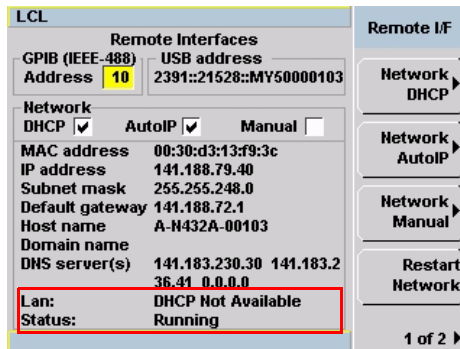

Figure 1-7 Example of the Lan Status message

Table 1-1 Lan Status messages

Message type	Description
Lan: No Fault Status: Initialized	A valid IP address is successfully obtained using the selected LAN configuration, and the network is initialized
Lan: No Fault Status: Running	A valid IP address is successfully obtained using the selected LAN configuration while the network is running
Lan: Fault Status: Initialization failed	<ul style="list-style-type: none"> • An IP conflict occurs, or • An IP address fails to be obtained using the selected LAN configuration, or • No LAN configuration is selected
Lan: Fault Status: Disconnected	The LAN cable is unplugged
Lan: – Status: Restarting	<ul style="list-style-type: none"> • The network is restarting • Trying to obtain an IP address using the selected LAN configuration
Lan: DHCP Not Available Status: Running	<ul style="list-style-type: none"> • Unable to obtain an IP address from the DHCP server (if DHCP configuration is selected) • An IP address will be obtained from the auto IP or manual configuration

Using the remote front panel

The N432A Web interface also provides a virtual front panel interface that can be used to control the N432A remotely.

- 1 On the left of the Welcome Page, select **Browser Web Control**. The virtual front panel will appear as shown below.

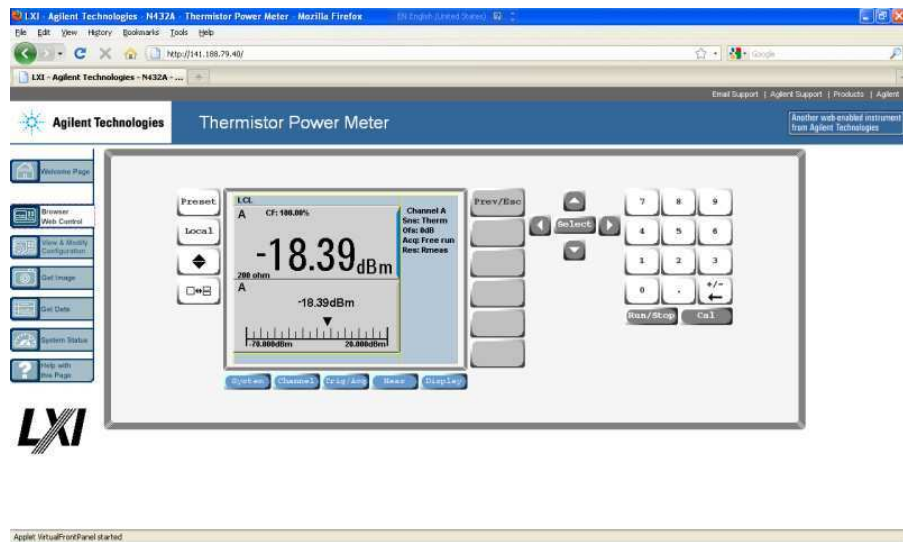

Figure 1-8 Virtual front panel

- 2 Click the front panel keys to control the N432A.

NOTE

Java™ must be installed on the controlling PC for remote front panel operation.

Editing the N432A LAN settings

Once the communication path to the N432A has been established, the N432A LAN configuration can be viewed and modified using the Web interface.

On the Welcome page, click **View and Modify Configuration** at the left of the page. This opens the configuration page as shown below.

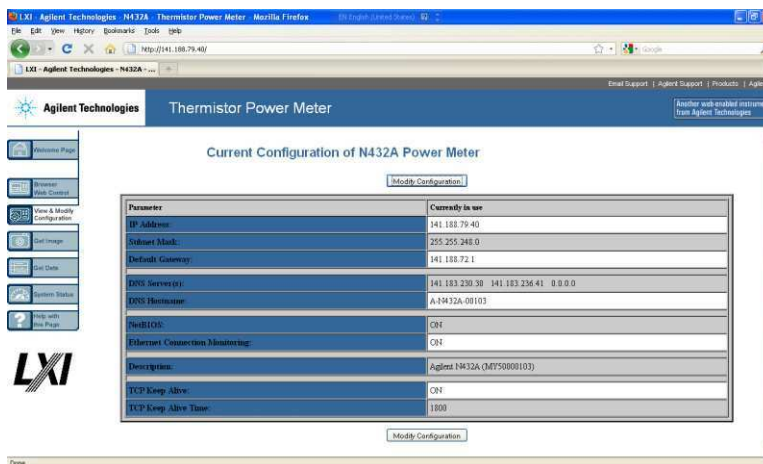

Figure 1-9 Viewing the current LAN configuration from the Web interface

To edit the available parameters, click **Modify Configuration**. The **Enter Password** dialog box will appear as follows.



Figure 1-10 Enter Password dialog box

Click **Submit** (to accept the default password), and the page as shown in **Figure 1-11** will be displayed. The default password is “**agilent**”.

NOTE

A LAN reset needs to be performed to ensure that the password is reset to default. The LAN reset procedure is as given below:

- 1 Press **System** > **Remote Interfaces** to display the **Remote Interfaces** screen.
- 2 Press **1 of 2** to display the second page of the **Remote I/F** menu.
- 3 Press **LAN Reset** to reset the LAN settings to default.

When **LAN Reset** is pressed, it will also change the GPIB address to default.

You can change the password from the **Configuring your N432A Power Meter** page as shown in **Figure 1-11**. Scroll down the **Parameter** column until you locate the **Change Password** parameter.

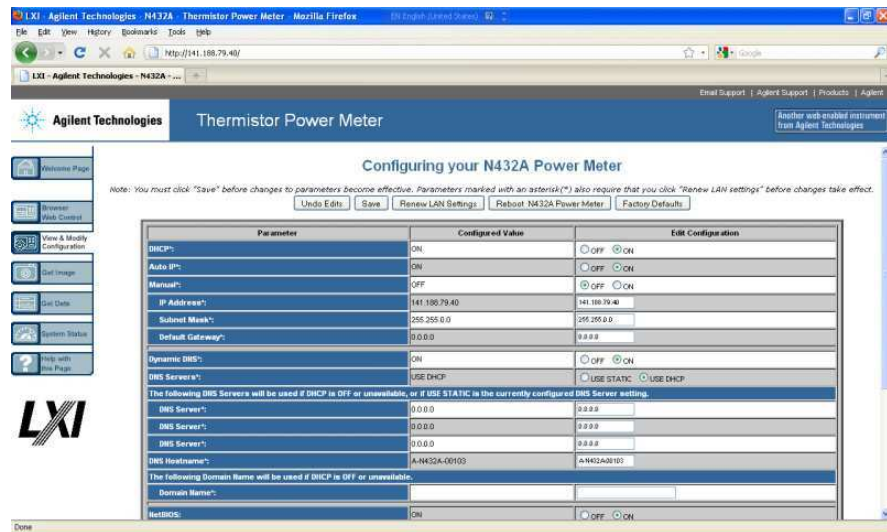

Figure 1-11 Changing the N432A LAN interface configuration

Capturing the screen image

Use the following steps to save the N432A display from the Web interface:

- 1 On the left of the Welcome Page, select **Get Image**. The screen image will be displayed as shown below.



Figure 1-12 Screen capture

- 2 Right-click on the image and select **Save Image As.....**
- 3 Select a storage location for the image file and click **Save**.

The image is saved as a bitmap (BMP) file to the default file name, display.bmp.

Getting the instrument data

The N432A Web interface allows you to transport measurement readings from the N432A to PC applications such as word and spreadsheet applications.

Use the following steps to obtain the instrument data.

- 1 On the left of the Welcome Page, select **Get Data**. The Get Data Web page will be displayed as shown below.

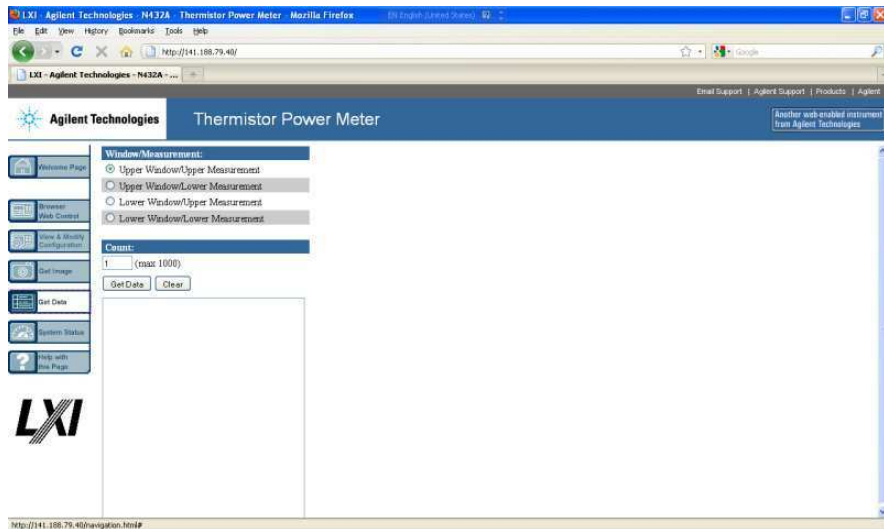



Figure 1-13 Obtaining instrument data

- 2 Select the window/measurement type of the N432A.
- 3 Enter your desired count value (up to 1000 only) of the data and click **Get Data**. The data will be displayed in a text box.
- 4 Copy and paste the data into your intended PC application.

Making the Socket Connection

The N432A can be connected remotely via the socket connection as explained in the following procedure.

- 1 Right-click the IO Control icon  of the Agilent IO Libraries Suite on the taskbar notification area, and select **Agilent Connection Expert**.
- 2 In the Agilent Connection Expert window, click  **Add Instrument** on the toolbar. An Add Instrument dialog will appear as shown below. Select the **Add LAN instrument on LAN (TCPIP0)** interface and click **OK**.

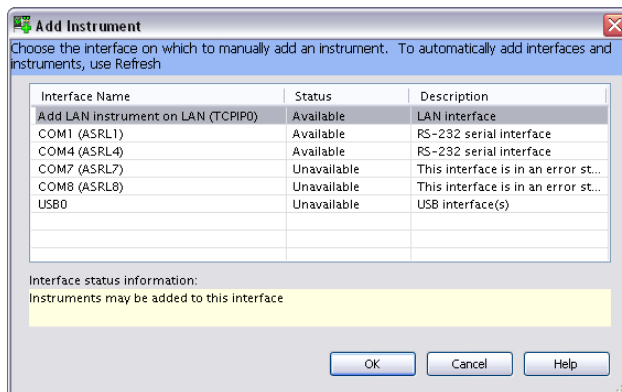

Figure 1-14 Add Instrument dialog

- 3 In the Add LAN Instruments dialog ([Figure 1-15](#)), click **Add Address** at the top of the dialog.
- 4 In the Enter Instrument Address panel, select the **Use IP Address** option and type the IP address. In the Optional Socket Connection panel, select the **Use socket connection** option.
- 5 Click **Test Connection** to verify if the N432A is present.
- 6 Click **OK**. You will then return to the Agilent Connection Expert window ([Figure 1-16](#)). Your N432A is now successfully connected via the socket connection.

1 Introduction

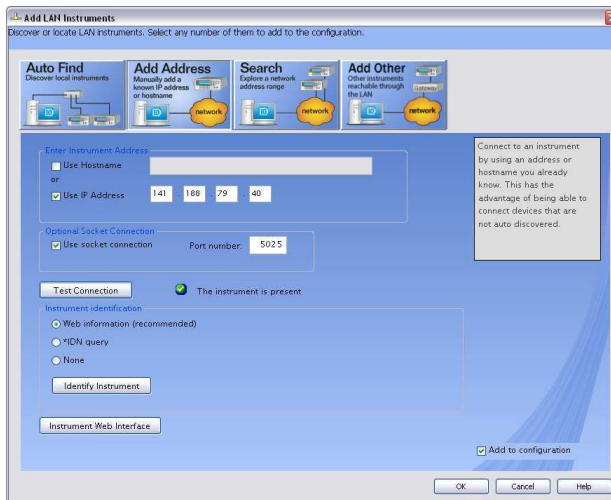

Figure 1-15 Add LAN Instruments dialog

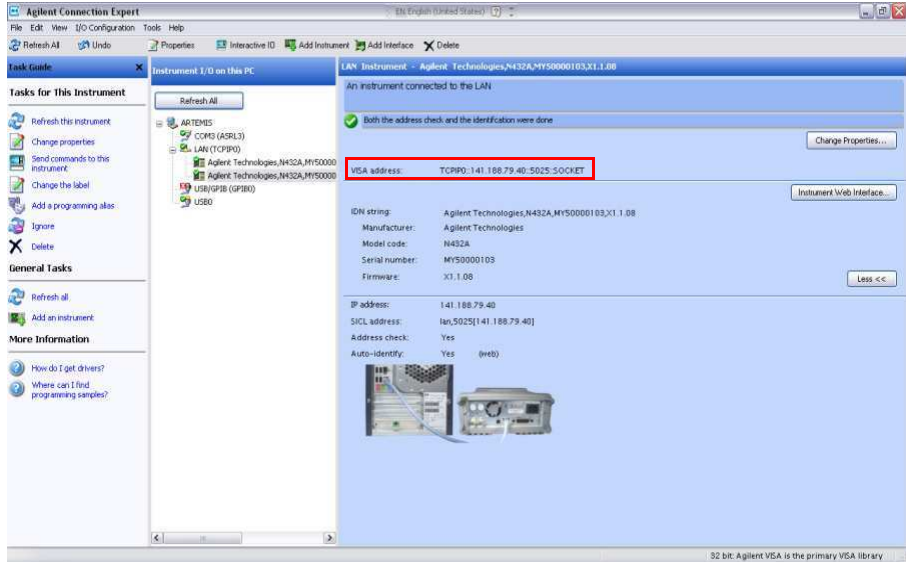
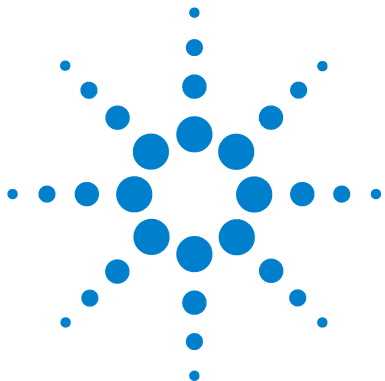

Figure 1-16 N432A connected via the socket connection



2 Operating Information

Setting the Bridge Resistance	30
Setting the Resistance Type	31
Setting the Measurement Unit	34
Setting the Measurement Frequency	35
Setting the Resolution	37
Displaying Voltage Measurements	38
Making Relative Measurements	39
Setting Offsets	41
Setting the Voltage Averaging	52
Setting Measurement Limits	54
Single Function Measurement	57
Combined Measurement	58
Max Hold/Min Hold	60
Recorder Output	63
Saving and Recalling N432A States	66
Zeroing the N432A	69
Using the Calibration/Correction Factors	70
Power Measurement Procedures	77
Voltage Standing Wave Ratio (VSWR) Measurement	82
Blank Screen	88
Secure Blank	89
Backlight Intensity Control	92
Memory Erase/Secure Erase	93
Warm Start	95

This chapter describes the general operation of the N432A thermistor power meter.



Setting the Bridge Resistance



A bridge resistance can be set for the thermistor sensor to balance bridges. There are four selectable bridge resistance values consisting of 100 Ω , 200 Ω , 300 Ω , and 400 Ω , with 200 Ω as the default value. The current resistance value is displayed on the measurement window as an indicator with or without the thermistor sensor connected.

If you have modified the bridge resistance value, the subsequent power-up value will correspond to the “[Warm Start](#)” state setting.

Upon each thermistor sensor connection, you will be informed of the current bridge resistance value and will be required to select a new resistance value or reconfirm the current desired resistance value.

Procedure

Use the following steps to set the bridge resistance.

- 1 Press  to access the channel setup screen.
- 2 Use the up/down arrow key to highlight the **Bridge Resistance** value field, and press  to display the Bridge Resistance pop-up list. Use the up/down arrow key to highlight the desired resistance value, and press  to enter the value.

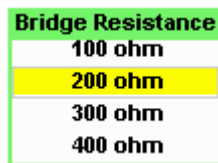



Figure 2-1 Bridge resistance pop-up list

- 3 Press  to exit the channel setup screen.

Setting the Resistance Type

Two resistance types consisting of Rmeas and Ruser can be selected, with Rmeas as the default type.

When Rmeas is selected, an externally measured bridge resistance value stored in EEPROM will be used. This value corresponds to the current bridge resistance setting, and is not editable via the front panel.

When Ruser is selected, you can enter a resistance value to be used in power measurement. The value of Ruser corresponds to the current bridge resistance setting, with a $\pm 10\%$ tolerance. If a value entered for Ruser exceeds the $\pm 10\%$ tolerance level of the bridge resistance, the value will be clipped to the upper/lower limit within tolerance.

You can measure the value of Ruser using the following steps:

- 1 Set up the connections as shown in the figure below. The positive and negative terminals of a digital multimeter (DMM) are connected to the indicated N432A channel A input connector pin and rear panel V_{RF} output connector pin respectively.

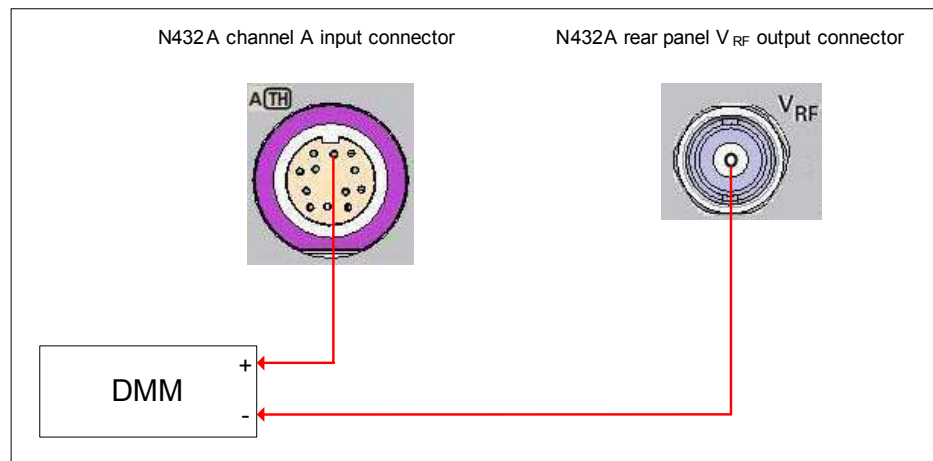

Figure 2-2 Connections for Ruser measurement

- 2 Set the DMM to measure resistance. The resistance value obtained is the Ruser value.

If you have modified the resistance type and the Ruser value, the subsequent power-up setting will correspond to the “Warm Start” state setting.

Procedure

Use the following steps to set the resistance type.





- 1 Press  to access the channel setup screen.
- 2 Use the up/down arrow key to highlight the **Res Type** value field, and press  to display the Res Type pop-up list. Use the up/down arrow key to highlight the desired bridge resistance type, and press  to enter the selection.



Figure 2-3 Resistance type pop-up list

- 3 When Ruser is selected, you can enter a resistance value within a $\pm 10\%$ tolerance level of the current bridge resistance setting. Use the left/right arrow key to highlight the resistance value field, then press  to display the Ruser pop-up. Use the numeric keypad to enter the required value and press **Enter** to confirm the entry.

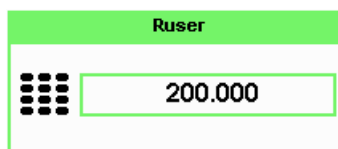





Figure 2-4 Ruser pop-up

- 4 Press  to exit the channel setup screen.

Setting the Measurement Unit

The **Units** menu is used to select the measurement unit for the currently selected window. The unit can either be logarithmic (dBm or dB) or linear (Watt or %). Presetting () the N432A sets the measurement unit to dBm. [Table 2-1](#) shows the units that are applicable to each measurement type.

Press  > **Units**. Select the unit of measurement from **dBm**, **W**, **dB**, and **%**. Softkeys which cannot be selected in your particular mode of operation are grayed out.

NOTE

When the measurement unit is set to Watt (W), it is possible that negative power results are displayed when measuring low power levels.

Table 2-1 Measurement units

Measurement mode	Relative mode Off	Relative mode On
Log	dBm	dB
Linear	Watt	%



Setting the Measurement Frequency

Entering the frequency of the RF signal you are measuring optimizes the accuracy and minimizes measurement uncertainty, especially when making comparative measurements between signals.

The frequency value field is only enabled when either the frequency-dependent offset table or sensor calibration table, or both, is turned on. For more information on these tables, refer to “[Setting Offsets](#)” on page 41 and “[Using the Calibration/Correction Factors](#)” on page 70.



Procedure

Use the following steps to set the measurement frequency.

- 1 Press  to access the channel setup screen.
- 2 Press **Offsets**, then use the up/down arrow key to highlight the **FDO Table** or **CF Table** setting field and press  to display the tables.
- 3 Use the up/down arrow key to highlight one of the table titles and press **Table** to highlight **On**.

NOTE

When no data is contained in the highlighted table, the **Table** key is disabled (grayed out).

- 4 Press  to complete the selection of the offset table and press  again to return to the channel setup screen. Press **Done** >  to complete the selection of the calibration table and return to the channel setup screen.

2 Operating Information

- 5 On the channel setup screen, use the up/down arrow key to highlight the **Frequency** value field and press  to display the **Frequency** pop-up. Use the numeric keypad to enter the required value.

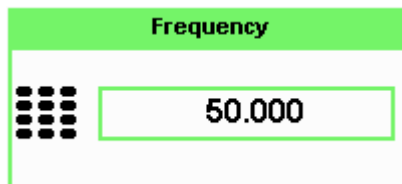



Figure 2-5 Frequency pop-up

- 6 Confirm your selection by pressing **MHz** or **GHz**.
- 7 Press  to exit the channel setup screen.

Setting the Resolution

The resolution of the N432A numeric type windows can be set to four different levels (1, 2, 3, or 4).

These four levels represent:

- 1, 0.1, 0.01, or 0.001 respectively if the measurement suffix is dBm or dB.
- 1, 2, 3, or 4 significant digits respectively if the measurement suffix is W or %.

The default resolution is 0.01 dBm or 3 significant digits.

Procedure

Use the following procedure to set the resolution on the currently selected window.

- 1 Press  to access the display format menu. The current resolution setting is highlighted under the **Resolution** softkey.
- 2 To change this setting, press **Resolution** repeatedly until the required resolution setting is highlighted.

Displaying Voltage Measurements

The N432A allows you to view the voltage measurement values for the selected measurement window. Values of V_0 , V_{COMP0} , V_{RF0} , V_1 , V_{COMP1} , and V_{RF1} are displayed together with the associated average power measurement value, PV_1 .

NOTE

PV_1 is obtained after any channel offset has been applied but prior to any display offset. For details on offset configuration, refer to “Setting Offsets” on page 41.

V_0 , V_{COMP0} , and V_{RF0} values are determined when zeroing is performed with the RF source disconnected. After zeroing, V_1 , V_{COMP1} , and V_{RF1} are measured with the RF source turned on.

The voltage measurement range for V_{RF} and V_{COMP} is -200 mV to 10 V. V_0 and V_1 have a default measurement range of -0.625 V to 1.875 V.

The values for V_{RF} and V_{COMP} are displayed in the VDC unit with a 6.5-digit resolution. The V_0 and V_1 values are displayed in VDC if the voltage value is more than 1 VDC and in mVDC if the voltage value is less than 1 VDC; with a 6.5-digit resolution.

Procedure

Use the following steps to display the voltage measurement values:

- 1 Press  to access the display format menu.
- 2 Press **1 of 2** and select **Voltages Display**. The voltage and average power measurement values will be displayed as shown in the example below:

LCL		Voltages Display
PARAMETER	VALUE	
V_0	12.5038 mVDC	
V_{COMP0}	4.92728 VDC	
V_{RF0}	4.91477 VDC	
V_1	12.3190 mVDC	
V_{COMP1}	4.92647 VDC	
V_{RF1}	4.91415 VDC	
PV_1	-5.48 dBm	

Figure 2-6 Voltage measurement display

Making Relative Measurements

Relative mode enables comparison of a measurement result to a reference value. The relative reading, or difference, can be displayed in either the dB or % term. When the measurement result is displayed in %, a prefix multiplier may be shown.

Procedure

Use the following steps to make relative measurements.

- 1 Press  to access the measurement setup screen.

Figure 2-7 shows a **Measurement Setup** display and the relative measurement items labeled.

- 2 Select the window you wish to set a reference value on by pressing **Meas Select**. The currently selected window/measurement configuration is displayed.
- 3 Use the up/down arrow key to highlight the **Relative** setting field.

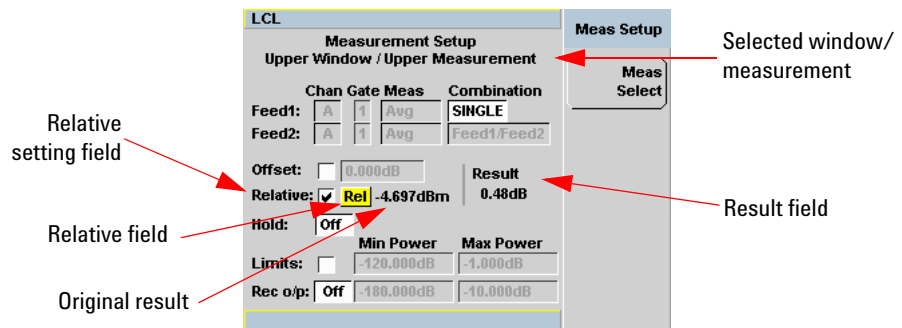



Figure 2-7 Typical relative measurement display

- 4 Press  to select the **Relative** setting field.
- 5 Confirm that the N432A is measuring the signal you want to use as the reference. This is displayed under the **Result** field.
- 6 Press the left/right arrow key to highlight the **Rel** field.

2 Operating Information

- 7 Press  and the original result value will appear on the right of the **Rel** field.
- 8 The relative value displayed under the **Result** field will change as the measured signal varies.

NOTE

If you return the N432A to the numeric display, a **Rel** symbol will be displayed in the measurement window it is applied to.

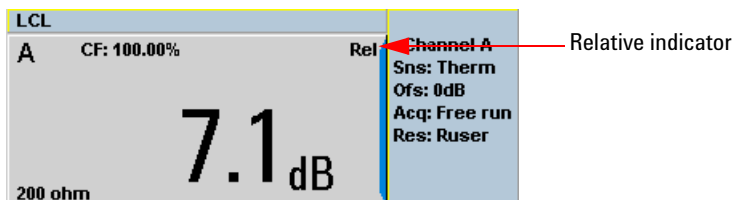

The **Rel** symbol will not be displayed when the associated measurement is displayed in the **Dual Numeric** or **Analog** format.

Setting Offsets

The N432A can be configured to compensate for a signal loss or gain in your test setup. The N432A allows you to apply offsets at three different points in the measurement path.

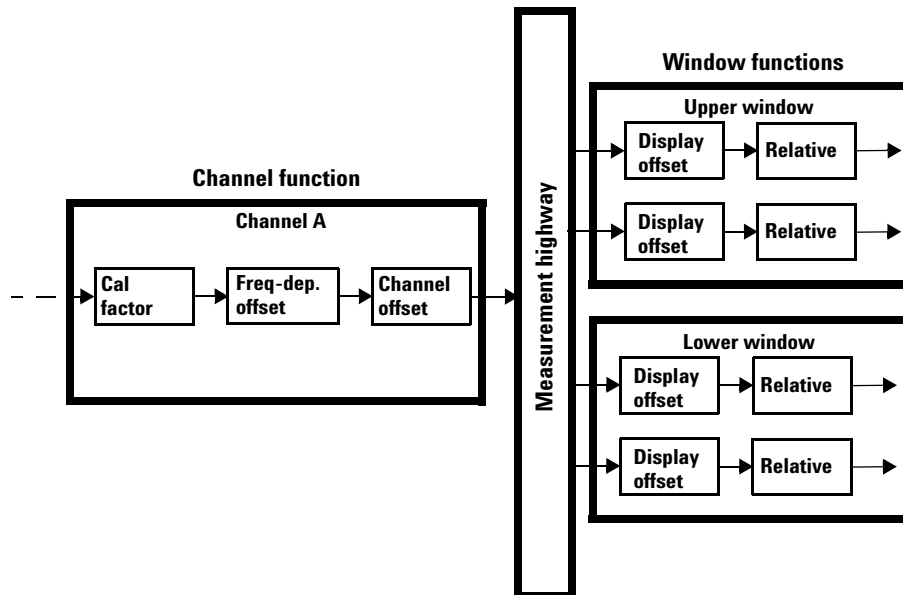

Figure 2-8 Simplified measurement path

The above figure shows that you can apply a **channel offset** or a **frequency-dependent offset** prior to any mathematical functions. This allows you to compensate the channel separately. An overall offset can be applied if required using the **display offset**.

Setting the channel offset

This gain or loss is applied to the measured power before any mathematical functions, display offsets, or relative functions are included.



The offset is entered in dB within the range of -100 dB to +100 dB.

The equivalent range in % is from 0.0000000001% to 10000000000%.

A positive value compensates for a loss, while a negative value compensates for a gain.

Procedure

Use the following steps to set a channel offset.

- 1 Press  to access the channel setup screen.
- 2 Press **Offsets** to display the channel offset setup screen.
- 3 Use the up/down arrow key to highlight the **Offset** setting field.
- 4 Press  to select the **Offset** setting field.

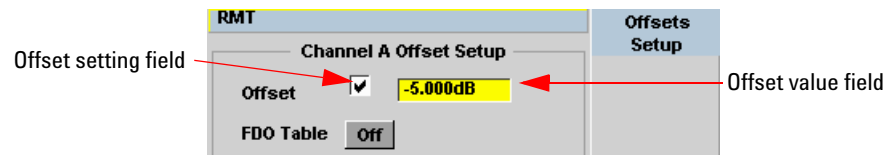



Figure 2-9 Setting the channel offset

- 5 Press the right arrow key to highlight the **Offset** value field and press  to display the Offset pop-up. Use the numeric keypad to enter the required value.
- 6 Confirm your entry by pressing **dB**.
- 7 Press  to exit the offset setup screen. If either a channel or a display offset is set, the **Ofs** indicator is displayed.

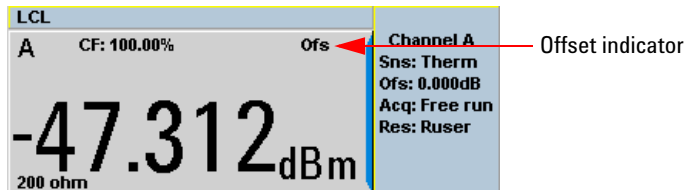

Figure 2-10 Offset indicator

NOTE

The **Ofs** indicator will not be displayed when the associated measurement is displayed in the Dual Numeric or Analog format.



Setting the display offset

This gain or loss is applied to the measured power after any channel offset or mathematical functions have been included.

The offset is entered in dB within the range of -100 dB to +100 dB. A positive value compensates for a loss, while a negative value compensates for a gain.

Procedure

Use the following steps to set a display offset on the currently selected window.

- 1 Press  to access the measurement setup screen.
- 2 Select the window you wish to set the offset value on by pressing **Meas Select**.
- 3 Use the up/down arrow key to highlight the **Offset** setting field.
- 4 Press  to select the **Offset** setting field.

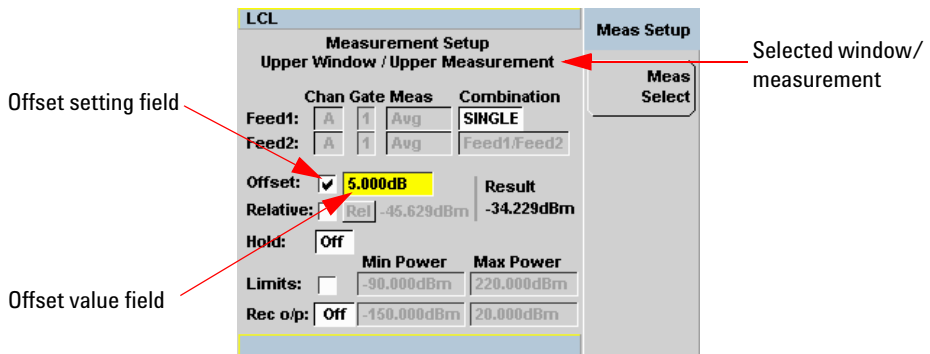



Figure 2-11 Setting the display offset

- 5 Press the right arrow key to highlight the **Offset** value field and press  to display the Display Offset pop-up. Use the numeric keypad to enter the required value.
- 6 Confirm your entry by pressing **dB**. Press  to exit the offset setup.

NOTE

The **Ofs** indicator will be displayed if the display offset is selected.

Setting the frequency-dependent offset

Frequency-dependent offset tables provide a quick and convenient method of compensating for frequency-related changes in the response of your test system. Note that when selected, frequency-dependent offset corrections are applied IN ADDITION to any correction for the sensor frequency response.

The N432A is capable of storing 10 frequency-dependent offset tables with a maximum of 80 frequency points each.

Selecting a frequency-dependent offset table



You can select a frequency-dependent offset table by pressing  > **Tables** > **Freq. Dep. Offset**.

NOTE

You need to enable the frequency-dependent offset table prior to configuring the measurement frequency value in the channel setup screen.

The Offset Tables screen is shown in [Figure 2-12](#). The State column indicates if any frequency-dependent offset (FDO) tables are currently selected.



NOTE

You can also view which FDO table is being used by pressing  > **Offsets**, then use the up/down arrow key to highlight the **FDO Table** setting field and press  to display the tables.

Procedure

Use the following steps to select an offset table.

1 Press either:

-  > **Tables** > **Freq. Dep. Offset**.
-  > **Offsets**, then use the up/down arrow key to highlight the **FDO Table** setting field and press  to display the tables.

2 Operating Information

LCL			Offset Tbls
Tbl Name	State	Pts	
A CUSTOM_A	off	0	Edit Table Table Off On
B CUSTOM_B	off	0	
C CUSTOM_C	off	0	
D CUSTOM_D	off	0	
E CUSTOM_E	off	0	
F CUSTOM_F	off	0	
G CUSTOM_G	off	0	
H CUSTOM_H	off	0	
I CUSTOM_I	off	0	
J CUSTOM_J	off	0	

1 of 1

Figure 2-12 Frequency-dependent offset tables

- 2 Use the up/down arrow key to highlight one of the 10 table titles and press **Table** to highlight **On**.

NOTE

When no data is contained in the highlighted table, the **Table** key is disabled (grayed out).

- 3 Press  to complete the selection of the offset table.
- 4 The following figure shows the indicator for the selected offset table.

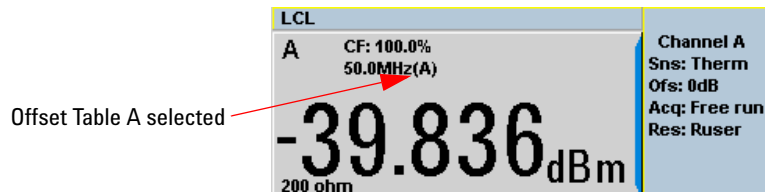

Figure 2-13 Frequency-dependent offset table indicator

NOTE

If a measurement frequency does not correspond directly to a frequency in the sensor calibration table (if selected) and the frequency-dependent offset table being used, the N432A calculates the calibration factor and offset using linear interpolation. If you enter a frequency outside the frequency range defined in the sensor calibration table or the frequency-dependent offset table, the N432A uses the highest or lowest frequency point in the appropriate table to set the calibration factor and offset.

Editing the frequency-dependent offset table

There are 10 frequency-dependent offset tables named **CUSTOM_A** through **CUSTOM_J**. They are empty of any data when the N432A is shipped from the factory.

You cannot delete any of the 10 existing frequency-dependent offset tables or create any additional tables. However, you can enter values into the 10 existing tables. Each frequency-dependent offset table can contain a maximum of 80 frequency points.

To view the frequency-dependent offset tables currently stored in the

N432A, press  > **Tables** > **Freq. Dep. Offset**.

Editing the offset tables requires the following steps:

- 1 Identify and select the table you want to edit
- 2 Rename the table
- 3 Enter the frequency and offset pairs
- 4 Save the table

Procedure

First, select the table you want to edit as follows:

NOTE

A frequency in the range of 0.001 MHz to 1000.0 GHz can be entered. An offset in the range of 0.00000001% to 10000000000000% can be entered.

- 1 Press  > **Tables** > **Freq. Dep. Offset** to access the Offset Tables screen.
- 2 Select the table you want to edit using the up/down arrow key. Press **Edit Table** to display the Edit Offset menu as shown in [Figure 2-14](#).

2 Operating Information

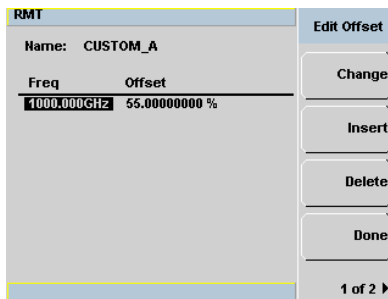

Figure 2-14 Edit Offset display with data added

- 3 Highlight the table title using the up/down arrow key. Press **Change** and use the arrow keys to select and change the characters in the Table Name pop-up to create the name you want to use.

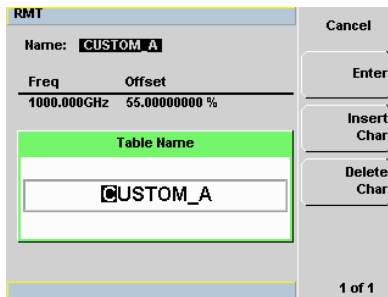

Figure 2-15 Edit table name pop-up

- Pressing **Insert Char** adds a new character to the right of the selected character.
 - Pressing **Delete Char** removes the selected character.
- 4 Press **Enter** to complete the entry.

NOTE

The following rules apply to naming the tables:

- The name must consist of not more than 12 characters.
- Space is not allowed as the first character.

Enter (or edit) the frequency and offset pairs as follows:

- 1 Press **Insert** to add a new frequency value (or press **Change** to edit). Use the numeric keypad to enter the required value in the Frequency pop-up. Complete the entry by pressing **GHz** or **MHz**.
- 2 Enter a new offset value (or press **Change** to edit). Use the numeric keypad to enter the required value in the Offset pop-up. Complete the entry by pressing **%**.

RMT		Offset Unit
Name: CUSTOM A		
Freq	Offset	
50.000MHz	50.00000000 %	dB
58.000GHz	45.00000000 %	%
		1 of 1

Figure 2-16 Setting the offset unit

- 3 Continue adding/editing values until you have entered all the required data.
- 4 Once completed, press **Done** to save the table.

NOTE

If you measure a signal with a frequency outside the frequency range defined in the frequency-dependent offset table, the N432A uses the highest or lowest frequency point in the frequency-dependent offset table to calculate the offset.

2 Operating Information

Frequency-dependent offset unit (dB or %)

The offset in dB ranges from -100 dB to +100 dB.

The range in % is from 0.00000001% to 1000000000000%.

Once the offset unit has been selected, it will be applied to all the offsets in the selected table and also to the remaining nine tables.

To change the offset unit to dB, press **1 of 2** > **Offset Unit** > **dB**.

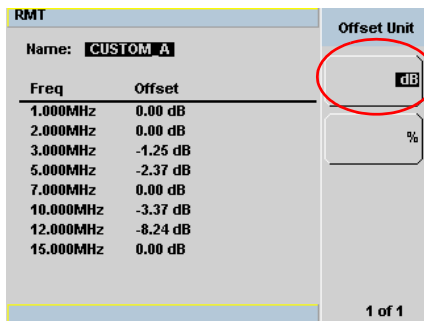

The screenshot shows the 'RMT' menu with 'Name: CUSTOM_A'. A table lists frequencies from 1.000MHz to 15.000MHz with their corresponding offsets in dB. To the right, the 'Offset Unit' menu is open, with 'dB' selected and circled in red. The bottom of the screen shows '1 of 1'.

Freq	Offset
1.000MHz	0.00 dB
2.000MHz	0.00 dB
3.000MHz	-1.25 dB
5.000MHz	-2.37 dB
7.000MHz	0.00 dB
10.000MHz	-3.37 dB
12.000MHz	-8.24 dB
15.000MHz	0.00 dB

To change the offset unit to %, press **1 of 2** > **Offset Unit** > **%**.

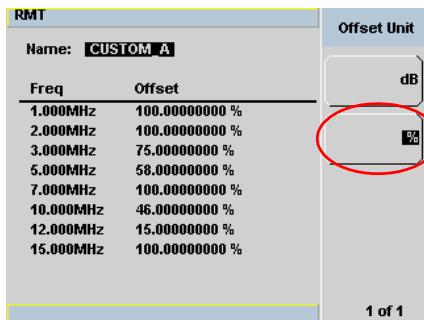

The screenshot shows the 'RMT' menu with 'Name: CUSTOM_A'. A table lists frequencies from 1.000MHz to 15.000MHz with their corresponding offsets in %. To the right, the 'Offset Unit' menu is open, with '%' selected and circled in red. The bottom of the screen shows '1 of 1'.

Freq	Offset
1.000MHz	100.00000000 %
2.000MHz	100.00000000 %
3.000MHz	75.00000000 %
5.000MHz	58.00000000 %
7.000MHz	100.00000000 %
10.000MHz	46.00000000 %
12.000MHz	15.00000000 %
15.000MHz	100.00000000 %

If the selected offset unit is %, the display of the offset will be in the engineering unit only if the percentage value is <0.01% or ≥10000%. The format of the display in the engineering unit for an offset ≥10000% will be shown as follows:

xxxx.yyyyyyy e+z

- There is a maximum of four numbers before the decimal point, indicated by **x**.
- **y** is optional if there are zero numbers after the decimal point.

For example,

- 123478202 will be displayed as 1234.78202000 e+5
- 10000 will be displayed as 1000.00000000 e+1.

The format of the display in the engineering unit for an offset <0.01% will be shown as follows:

x.yyyyyyy e-z

- The first leading non-zero number, **x**, is placed before the decimal point.
- **y** is optional if there are zero numbers after the decimal point.

For example,

- 0.009876 will be displayed as 9.8760000 e-3
- 0.0001 will be displayed as 1.0000000 e-4.

RMT		Edit Offset
Name: CUSTOM A		Change
Freq	Offset	Insert
1.000MHz	1234.78202000 e+5%	Delete
2.000MHz	100.00000000 %	Done
3.000MHz	75.00000000 %	
5.000MHz	1000.00000000 e+2 %	
7.000MHz	100.00000000 %	
10.000MHz	1.0000000 e-5 %	
12.000MHz	15.00000000 %	
15.000MHz	100.00000000 %	
		1 of 2 ▶



Figure 2-17 Offset display in the engineering unit (when the selected unit is %)

Setting the Voltage Averaging

Voltage averaging can be set for the thermistor sensor to be used in the calculation of the incident power. There are four selectable averages consisting of 4, 8, 16, 32, 64, and 128, with 16 as the default value.

Procedure

Use the following steps to set the voltage averaging.

- 1 Press  to access the channel setup screen.
- 2 Use the up/down arrow key to highlight the **Meas Avg** setting field.
- 3 Press  to display the Volt Avg pop-up list, and use the up/down arrow key to step through the available values. Press  to enter the required value.

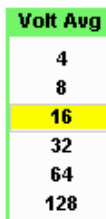

Volt Avg
4
8
16
32
64
128

Figure 2-18 Volt Avg pop-up list



- 4 Press  to exit the channel setup screen.

Step Detection

To reduce the filter settling time after a significant step in the measured power, the filter can be set to re-initialize upon detection of a step increase or decrease in the measured power.

Procedure

Use the following steps to set the step detection.

- 1 Press  to access the channel setup screen.
- 2 Use the up/down arrow key to highlight the **Step Detect** setting field.
- 3 Press  to toggle between turning on or off the step detection.
- 4 Press  to exit the channel setup screen.

Setting Measurement Limits

You can configure the N432A to detect when a measurement has crossed over a predefined upper and/or lower limit value.

Limits are boundaries set for a certain power range and it can be applied to the power, ratio, or difference measurement.



The N432A can be configured to verify the current measurement in any measurement line against predefined upper and/or lower limit values. The range of values that can be set for the upper and lower limits and the default values depend on the measurement units in the currently selected measurement line, as listed in the following table:

Table 2-2 Range of values for window limits

Window unit	Maximum	Minimum	Default maximum	Default minimum
dB	+200 dB	-180 dB	60 dB	-120 dB
dBm	+230 dBm	-150 dBm	90 dBm	-90 dBm
%	999.9 X%	100.0 a%	100.0 M%	100.0 p%
W	100.000 XW	1.000 aW	1.000 MW	1.000 pW

Procedure

The following procedure describes how to set the limits.

- 1 Press  > **Meas Select** to select the required window/measurement.
- 2 Use the up/down arrow key to highlight the **Limits** setting field.
- 3 Press  to select the **Limits** setting field.
- 4 Use the right arrow key to highlight the **Min Power** value field.
- 5 Press  to display the **Minimum Limit** pop-up (if the current unit is dBm or dB) or the **Meter Minimum** pop-up (if the current unit is W or %).

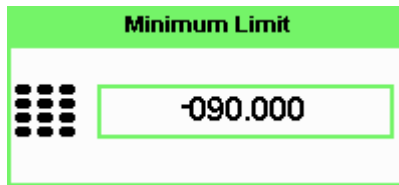

Figure 2-19 Minimum limit pop-up

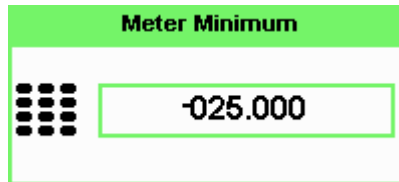



Figure 2-20 Meter minimum pop-up

- 6 If the current unit is dBm or dB, use the numeric keys to enter the required value and press **dBm** or **dB**. If the current unit is % or W, use the numeric keys to enter the required value and press **%** or **mW**, **μW**, **nW** respectively. You can modify the unit multiplier by pressing **1 of 2**, followed by **Increment Multiplier** or **Decrement Multiplier**. Press the corresponding unit multiplier softkey above **Increment Multiplier** to enter your selection.
- 7 Now, use the right arrow key to highlight the **Max Power** value field.
- 8 Press  to display the **Maximum Limit** pop-up (if the current unit is dBm or dB) or the **Meter Maximum** pop-up (if the current unit is W or %).
- 9 Repeat Step 6 and press  to exit the measurement setup screen.

NOTE

The Limits setting can be disabled and re-enabled by selecting the **Limits** setting field.

Checking for limit failures

A limit failure is displayed on a specific field in the measurement window as shown below.

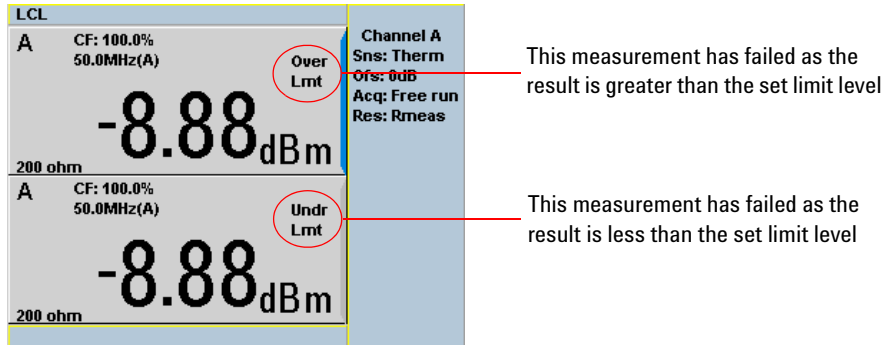

Figure 2-21 Limit failures

Single Function Measurement

The following figure shows a single function measurement configuration for the upper measurement line of the upper display window.

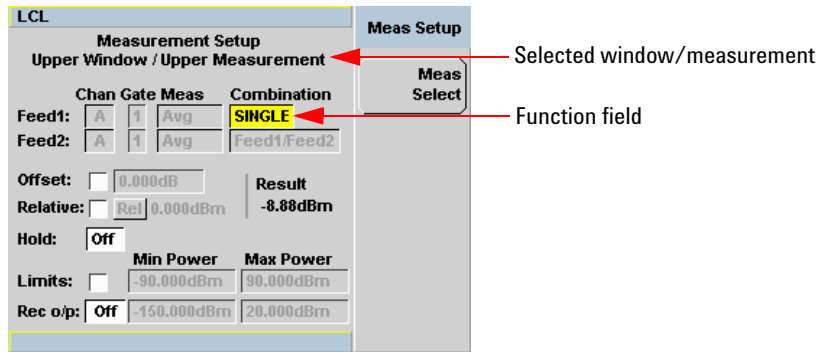

Figure 2-22 Single function measurement configuration

Procedure

Use the following the procedure to set the single function measurement:





- 1 Press  > **Meas Select** to select the required window/measurement.
- 2 Use the arrow keys to highlight the **Combination** function field.
- 3 Press  to display the Function pop-up list, and use the up/down arrow key to highlight **Single**.



Figure 2-23 Function pop-up list

- 4 Press  to enter the selection.
- 5 Press  to complete the setup and display the measurement results.

Combined Measurement

The following figure shows a combined measurement configuration where a ratio measurement is assigned in the upper measurement line of the lower display window.

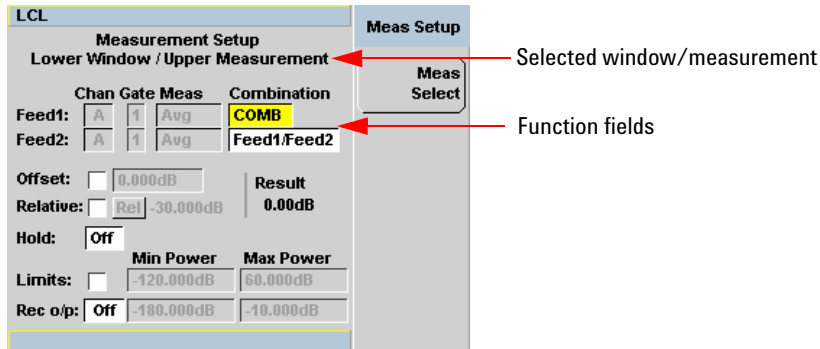







Figure 2-24 Combined measurement configuration

Procedure

Use the following procedure to set the combined measurement:

- 1 Press  > **Meas Select** to select the required window/measurement.
- 2 Use the arrow keys to highlight the **Combination** function field.
- 3 Press  to display the Function pop-up list (Figure 2-23), and use the up/down arrow key to highlight **Combined**.
- 4 Press  to enter the selection.
- 5 To select the measurement type of either ratio or difference, use the arrow keys to highlight the **Feed1/Feed2** function field.
- 6 Press  to display the Combination pop-up list, and use the up/down arrow key to highlight the required measurement type.

- 7 Press  to enter the selection.
- 8 Press  to complete the setup and display the measurement results.

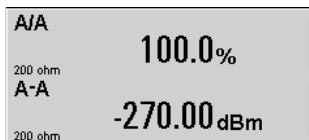



Figure 2-25 Measurement display example

Max Hold/Min Hold

The max hold/min hold setting on the measurement setup window can be configured on the front panel or via SCPI.

Min hold is the minimum of all measurements since the start time. The min hold reading will be updated as a new minimum reading appears.

Max hold is the maximum of all measurements since the start time. The max hold reading will be updated as a new maximum reading appears.

The max hold/min hold reading are resettable by pressing .

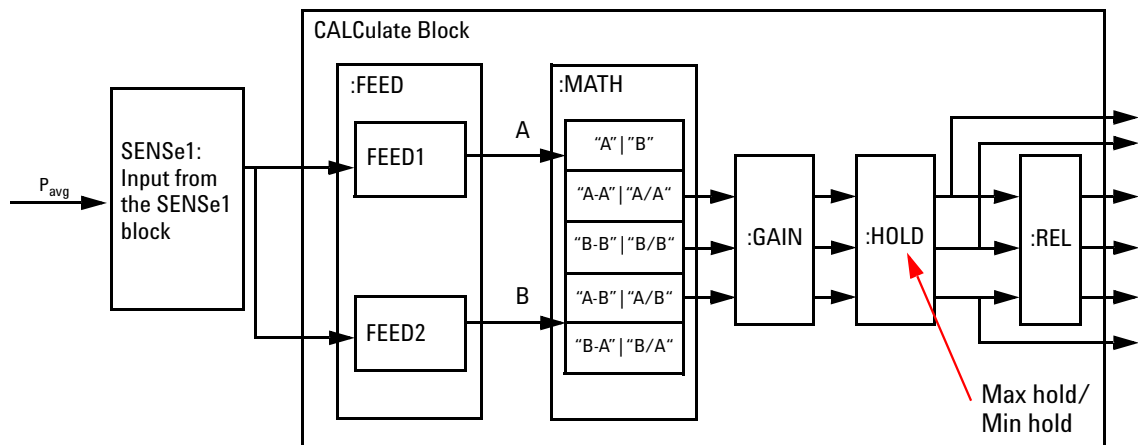

Figure 2-26 Max hold/min hold measurement performed on the 'HOLD' block

Procedure

Use the following steps to set max hold/min hold.





- 1 Press  to access the measurement setup screen.
- 2 Use the up/down arrow key to highlight the **Hold** setting field.
- 3 Press  to display the **Hold** pop-up list, and use the up/down arrow key to highlight **Min** or **Max**.



Figure 2-27 Hold pop-up list

- 4 Press  to enter the selection.
- 5 Press  to complete the setup and display the measurement results.

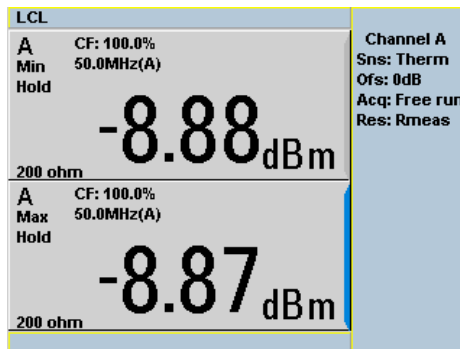



Figure 2-28 Min Hold and Max Hold measurement modes indicated on the display

- 6 Press  to display the measurement window in the full screen mode. The max hold/min hold is indicated in full in the expanded window as shown in [Figure 2-29](#).

2 Operating Information

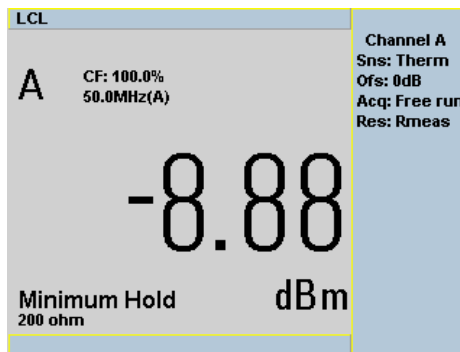



Figure 2-29 Min Hold indicated in full in the expanded window

Recorder Output

The rear panel **Recorder Output** connector produces a DC voltage that corresponds to the power level in Watts of the channel depending on the measurement type. This DC voltage ranges from 0 to +1 Vdc. The output impedance is typically 1 k Ω , while channel and display offsets and duty cycle have no effect on the recorder output.

For example, the recorder output can be used to:

- Record swept measurements
- Level an output from a source using external leveling, or
- Monitor the output power

To access the **Recorder** menu, press , and enable **Rec**. This allows you to switch the recorder output signal on or off, or to enable or disable autoscaling of the signal. The **Max Power** and **Min Power** value fields allow you to scale the power levels to represent the 1 Vdc maximum and 0 Vdc minimum output voltages of the recorder output.

Procedure

Use the following steps to set the recorder output.



- 1 Press  > **Meas Select** to select the required window/measurement.
- 2 Use the up/down arrow key to highlight the **Rec** setting field.
- 3 Press  to display the Recorder pop-up list.



Figure 2-30 Recorder output pop-up list

2 Operating Information

- 4 Use the up/down arrow key to highlight the required option and press



- 5 If **On** is selected, use the right arrow key to highlight the **Min Power** value field.

- 6 Press  to display the Recorder Minimum pop-up.

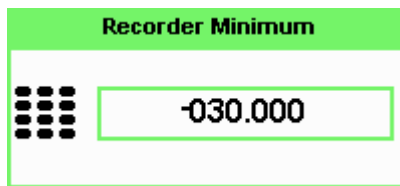



Figure 2-31 Recorder Minimum pop-up

- 7 Use the numeric keys to enter the power level you want to generate a 1 Vdc output in the **Recorder Minimum** pop-up, and press the corresponding unit softkey.

- 8 Use the right arrow key to highlight the **Max Power** value field.

- 9 Press  to display the Recorder Maximum pop-up.

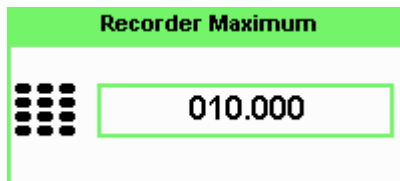



Figure 2-32 Recorder Maximum pop-up

- 10 Use the numeric keys to enter the power level you want to generate a 0 Vdc output in the **Recorder Maximum** pop-up, and press the corresponding unit softkey.

- 11 Press  to exit the measurement setup screen.

NOTE

The recorder output can be disabled and re-enabled by selecting the **Rec** setting field.

The highest power you are going to measure is used to determine the value which you should set for the recorder output maximum setting. For example, if you are measuring a power less than 1 mW and greater than 100 mW, set the recorder maximum value to 1 mW.

Table 2-3 Ranges of the recorder output setting

Log	50 dBm	40 dBm	30 dBm	20 dBm	10 dBm	0 dBm
Linear	100 W	10 W	1 W	100 mW	10 mW	1 mW

Log	-10 dBm	-20 dBm	-30 dBm	-40 dBm	-50 dBm	-60 dBm
Linear	100 mW	10 mW	1 mW	100 nW	10 nW	1 nW

Saving and Recalling N432A States

To reduce repeated setup sequences, you can save a maximum of 10 N432A states in the non-volatile memory.

The save and recall functions are part of the **Sys/Inputs** menu, accessed by pressing .

Procedure

Use the following steps to save a measurement setup.

- 1 Press  > **Save/Recall** to display the **Save/Recall** screen as shown below.

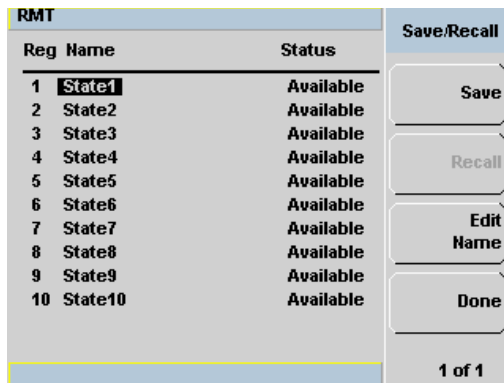

Figure 2-33 Save/Recall screen

- 2 Using the up/down arrow key, select a register name from the displayed list. To change the name of a register, refer to [“Editing a register name”](#), otherwise press **Save**.
- 3 The N432A will prompt you to press **Confirm** to proceed.



Figure 2-34 Save confirmation pop-up dialog

Editing a register name

Procedure

Use the following steps to edit the name of a register.

- 1 Press **System** > **Save/Recall**.
- 2 Use the up/down arrow key to select the required register and press **Edit Name**. The current register name will be displayed as shown in the following example.

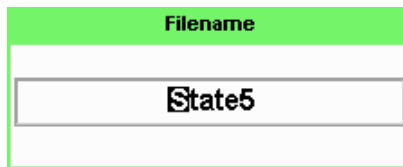

Figure 2-35 File name pop-up

- 3 Use the up/down arrow key to modify the character on which the cursor is currently positioned.
- 4 Use the left/right arrow key to move to other characters.
- 5 Use **Insert Char** and **Delete Char** as required.
- 6 To confirm your selection, press **Enter**.

Recalling a measurement setup

Procedure

Use the following steps to recall a measurement setup.

- 1 Press **System** > **Save/Recall**.
- 2 Use the up/down arrow key to select the required register, and press **Recall**. The **Recall** softkey is disabled (grayed out) when an unused register is selected.
- 3 The N432A will prompt you to press **Confirm** to proceed.

2 Operating Information

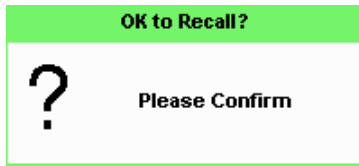

Figure 2-36 Recall confirmation pop-up dialog

Zeroing the N432A

Zeroing adjusts the N432A for a zero power reading with no power applied to the thermistor sensor. During zeroing (which takes approximately 25 seconds), the wait symbol is displayed.



Figure 2-37 Zeroing pop-up message

NOTE

Upon each thermistor sensor connection, you will be prompted for bridge resistance selection or reconfirmation, followed by confirmation to proceed with zeroing.

When to perform zeroing?

Zeroing of the N432A is recommended:

- when a 5°C change in temperature occurs.
- when connection to the thermistor sensor is established.
- when you change the thermistor sensor.
- every 24 hours.
- prior to measuring low-level signals.

To zero the N432A:

Press **Cal** > **Zero**. You will be prompted to confirm whether the thermistor sensor has been disconnected from the RF source. Once **Confirm** is pressed, zeroing will begin. If **Cancel** is pressed, the screen will revert to the Zero/Cal menu.

Using the Calibration/Correction Factors

The N432A provides two methods of using the calibration factors:



- inputting an individual calibration factor for a frequency prior to making the measurement, or
- using sensor calibration tables.

If you are making most of your measurements at a single frequency, or in a narrow range of frequencies, entering a specific calibration factor is a more effective method. Only a minimal amount of data entry is required.

However, if you are making measurements on a wide range of signal frequencies, a sensor table is more effective as you only need to enter the frequency of the signal you are measuring. The N432A automatically selects and applies the calibration factor from the selected table.

Frequency-specific calibration factors

Use the following procedure to set the calibration factor for the frequency of the signal you want to measure.

- 1 Check the current calibration factor setting by pressing  > **Offsets**. The value is displayed on the **Cal Fac** setting field.
- 2 Verify that the value matches the calibration factor of the sensor listed in the calibration factor table on the sensor body.
- 3 To change the setting, use the up/down arrow key to highlight the **Cal Fac** setting field and press  to display the **Cal Factor** pop-up. Use the numeric keypad to enter the required value.

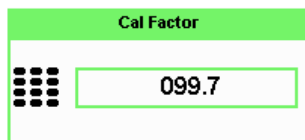

Figure 2-38 Cal Factor pop-up

- 4 Press **%** to complete the entry.

NOTE

When no sensor tables are selected and the **Single Numeric** display mode is chosen, the calibration factor used for the measurement is displayed in the upper window.

Sensor calibration tables

Sensor calibration tables store the measurement calibration factors for thermistor sensors in the N432A. They are used to correct measurement results.

Use sensor calibration tables when you want to make measurements over a range of signal frequencies.

The N432A is capable of storing 20 sensor calibration tables, each containing up to 80 frequency points. The N432A is supplied with a set of two predefined sensor calibration tables plus a “100%” default table. The data in these tables is based on statistical averages for a range of Agilent thermistor sensors. Your own sensor will most likely differ from the typical to some degree. If you require best accuracy, create a custom table for each sensor you use as described in [“Editing/generating sensor calibration tables”](#) on page 73.

Selecting a sensor calibration table



You can select a calibration factor table from  > **Tables** > **Sensor Cal Tables**.

NOTE

You need to enable the calibration factor table prior to configuring the measurement frequency value in the channel setup screen.

The State column indicates if any calibration factor tables are currently selected. The **Sensor Tbls** screen is shown in [Figure 2-39](#).

NOTE

You can also access the sensor calibration tables by pressing  > **Offsets** and using the up/down arrow key to highlight the **CF Table** setting field and pressing  to display the tables.

2 Operating Information

Procedure

Use the following procedure to select a sensor calibration table:

- 1 Press **System** > **Tables** > **Sensor Cal Tables**.
- 2 Use the up/down arrow key to highlight one of the 20 table titles and press **Table** to highlight **On**.

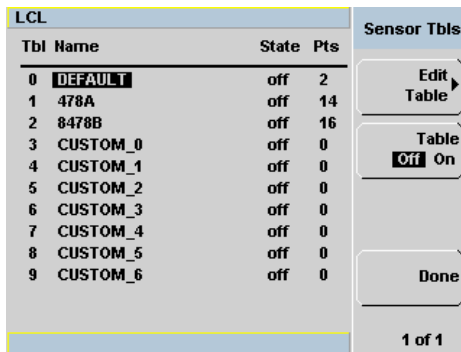

LCL			Sensor Tbls	
Tbl Name	State	Pts		
0 DEFAULT	off	2	Edit Table	
1 478A	off	14	Table Off On	
2 8478B	off	16		
3 CUSTOM_0	off	0		
4 CUSTOM_1	off	0		
5 CUSTOM_2	off	0		
6 CUSTOM_3	off	0		
7 CUSTOM_4	off	0		
8 CUSTOM_5	off	0		
9 CUSTOM_6	off	0		

Done

1 of 1

Figure 2-39 Sensor table selected

NOTE

When no data is contained in the highlighted table, the **Table** key is disabled (grayed out).

- 3 Press **Done** to complete the selection of the calibration factor table.
- 4 The following figure shows the selected table.

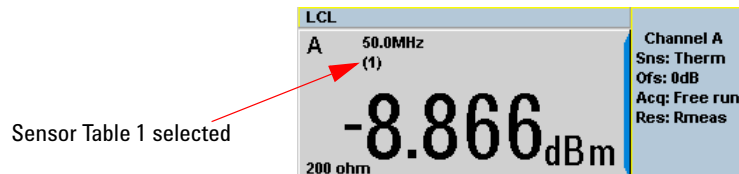



Figure 2-40 Sensor calibration table indicator

NOTE

- If the measurement frequency does not correspond directly to a frequency in the sensor calibration table, the N432A calculates the calibration factor using linear interpolation.
- If you enter a frequency outside the frequency range defined in the sensor calibration table, the N432A uses the highest or lowest frequency point in the sensor calibration table to set the calibration factor.
- When the **Single Numeric** display mode is chosen, the frequency you entered and the sensor table indicator will be displayed in the upper window. Also, pressing  > **Offsets** displays the frequency you entered and the calibration factor derived from the selected sensor table.

Editing/generating sensor calibration tables

To help achieve the best accuracy in your measurement, you can enter the values supplied for the sensors you are using by editing the installed sensor calibration tables or by generating your own custom tables.

You cannot delete any of the 20 existing calibration tables or create any additional tables. However, you can edit or delete the contents of each table. If you need another table, you should edit and rename one of the tables. Each calibration table can contain a maximum of 80 frequency points.

To view the calibration tables currently stored in the N432A, press

 > **Tables** > **Sensor Cal Tables**. The **Sensor Tbls** screen is displayed as shown in [Figure 2-41](#).

Table 2-4 Installed thermistor sensor models

Table	Sensor model
0	DEFAULT ^[1]
1	478A
2	8478B

[1] DEFAULT is a sensor calibration table where the reference calibration factor and calibration factors are 100%. This sensor calibration table can be used during the performance testing of the N432A.

There are also 17 sensor calibration tables named **CUSTOM_0** through **CUSTOM_16**. These tables do not contain any data when the N432A is shipped from the factory.

Editing the sensor calibration tables require the following steps:

- 1 Identify and select the table you want to edit
- 2 Rename the table
- 3 Enter the frequency and calibration factor pairs
- 4 Save the table

Procedure

First, select the table you want to edit as follows:

- 1 Press  > **Tables** > **Sensor Cal Tables** to display the **Sensor Tbls** screen.

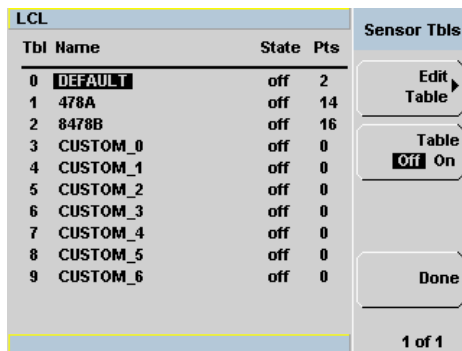

Figure 2-41 Sensor Tbls screen

- 2 Select the table you want to edit using the up/down arrow key. Press **Edit Table** to display the **Edit Cal** screen as shown below.

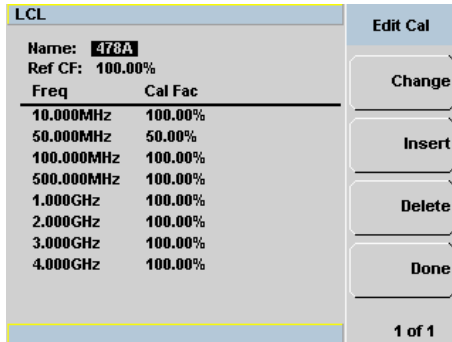

Figure 2-42 Edit Cal display

- 3 Highlight the table title using the up/down arrow key. Press **Change** and use the arrow keys to select and change the characters in the **Table Name** pop-up to create the name you want to use.

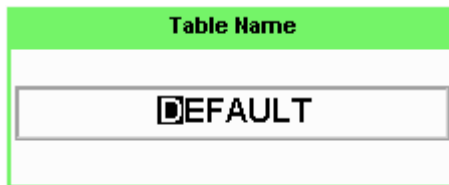

Figure 2-43 Edit table title pop-up

- Pressing **Insert Char** adds a new character to the right of the selected character.
 - Pressing **Delete Char** removes the selected character.
- 4 Press **Enter** to complete the entry.

NOTE

A calibration factor in the range of 1% to 150% can be entered.

The following rules apply to naming sensor calibration tables:

- The name must consist of no more than 12 characters.
 - Space is not allowed as the first character.
-

Enter (or edit) the frequency and calibration factor pairs as follows:

- 1** Press **Insert** to add a new frequency value (or press **Change** to edit). Use the numeric keypad to enter the required value in the **Frequency** pop-up. Complete the entry by pressing **GHz** or **MHz**.
- 2** Enter the new cal factor value (or press **Change** to edit). Use the numeric keypad to enter the required value in the **Cal Factor** pop-up. Complete the entry by pressing **%**.
- 3** Continue adding or editing values until you have entered all the required data.
- 4** When you have finished editing the table, press **Done** to save the table.

NOTE

Ensure that the frequency points you use cover the frequency range of the signals you want to measure. If you measure a signal with a frequency outside the frequency range defined in the sensor calibration table, the N432A uses the highest or lowest frequency point in the sensor calibration table to calculate the offset.





Power Measurement Procedures

This section describes how to perform two types of power measurement:



- Power measured internally by the N432A.
- Power obtained through calculation of V_{RF} and V_{COMP} measured by external digital multimeters.

Internal power measurement

The following procedure guides you on how to perform a basic power measurement on the N432A.

- 1 Preset the N432A to its default state by pressing .
- 2 Connect a thermistor sensor to the channel A input connector of the N432A.
- 3 A message will appear to inform you of the current bridge resistance value and require you to select a new resistance value or reconfirm the current resistance value. Use the softkeys to select the desired value.
- 4 You will then be prompted for confirmation to proceed with zeroing. Press **Confirm** to proceed.
- 5 Another message will appear, prompting you to confirm whether the sensor has been disconnected from the RF source. Press **Confirm** once you have verified that there is no RF source connected.
- 6 Zeroing will start automatically. The Zeroing pop-up message will be displayed during the zeroing process.
- 7 Enable the sensor calibration table by pressing  > **Offsets**, then using the up/down arrow key to highlight the **CF Table** setting field, and pressing  to display the tables. Use the up/down arrow key to select the required table and press **Table** to highlight **On**. Press **Done** >  to complete the table selection and return to the channel setup screen.

2 Operating Information

- 8 Enter the frequency of the RF signal you are measuring by using the up/down arrow key to highlight the **Frequency** setting field, and pressing . Use the numeric keypad to enter the required value in the Frequency pop-up, then press either **MHz** or **GHz**. The N432A will automatically select and apply the calibration factor from the selected table based on the entered frequency. Press  > **Offsets** to check the calibration factor value on the **Cal Fac** setting field.
- 9 Now, connect the sensor to the RF signal to be measured.
- 10 The corrected measurement result will be displayed.

Precision power measurement

In this method, power is calculated using differential voltages (V_0 and V_1) obtained by measuring V_{RF} and V_{COMP} outputs with external digital multimeters. This method helps to reduce measurement error to $\pm (0.2\%+0.5 \mu\text{W})$.

To use this method, first you need to perform zeroing of the N432A and measure its V_{RF} and V_{COMP} outputs using external digital multimeters. These V_{RF} and V_{COMP} are equivalent to V_{RF0} and V_{COMP0} . From this, you will obtain V_0 which is the difference between V_{COMP0} and V_{RF0} . Then, you need to connect RF power to the thermistor sensor and measure the V_{RF} and V_{COMP} outputs again. These V_{RF} and V_{COMP} are now equivalent to V_{RF1} and V_{COMP1} , which will give you a differential voltage of V_1 . Power can then be computed by incorporating these values in the following power equation:

$$P = \frac{2(V_{COMP1}V_1 - V_{COMP0}V_0) + V_0^2 - V_1^2}{4R\epsilon}$$

where,

- V_{COMP0} is the temperature compensation bridge top voltage measured when zeroing is performed with the RF source disconnected
- V_{COMP1} is the temperature compensation bridge top voltage measured after zeroing with the RF source connected
- $V_0 = V_{COMP0} - V_{RF0}$, without incident RF power
- $V_1 = V_{COMP1} - V_{RF1}$, with incident RF power
- R is the bridge resistance
- ϵ is the correction factor/effective efficiency

2 Operating Information

The following procedure guides you on how to perform a precision power measurement with the N432A.

- 1 Preset the N432A to its default state by pressing .
- 2 Set up the following connections in which the HI and LO terminals of two Agilent 3458A digital multimeters are connected to the N432A rear panel V_{RF} and V_{COMP} outputs.

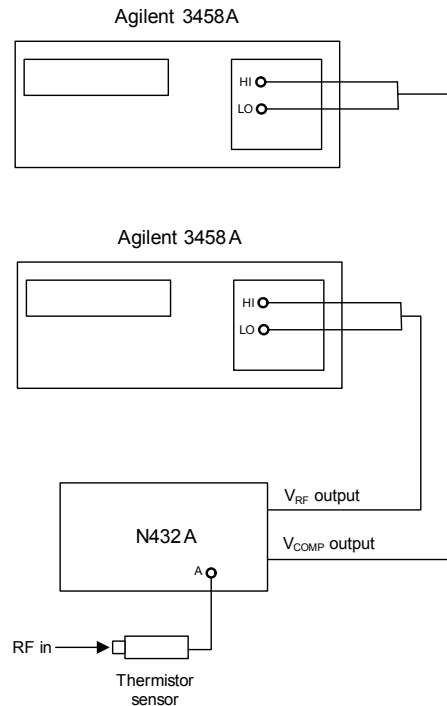







Figure 2-44 Connection diagram for precision power measurement

- 3 Turn off or disconnect the RF power from the thermistor sensor.
- 4 Upon connecting the sensor to the N432A channel A, a message will appear to inform you of the current bridge resistance value and require you to select a new resistance value or reconfirm the current resistance value. Use the softkeys to select the desired value.
- 5 You will then be prompted for confirmation to proceed with zeroing. Press **Confirm** to proceed.

- 6 Another message will appear, prompting you to confirm whether the sensor has been disconnected from the RF source. Press **Confirm** once you have verified that there is no RF source connected.
- 7 Zeroing will start automatically. The Zeroing pop-up message will be displayed during the zeroing process.
- 8 Enable the sensor calibration table by pressing  > **Offsets**, then using the up/down arrow key to highlight the **CF Table** setting field, and pressing  to display the tables. Use the up/down arrow key to select the required table and press **Table** to highlight **On**. Press **Done** >  to complete the table selection and return to the channel setup screen.
- 9 Enter the frequency of the RF signal you are measuring by using the up/down arrow key to highlight the **Frequency** setting field, and pressing . Use the numeric keypad to enter the required value in the Frequency pop-up, then press either **MHz** or **GHz**. The N432A will automatically select and apply the calibration factor from the selected table based on the entered frequency. Press  > **Offsets** to check the calibration factor value on the **Cal Fac** setting field.
- 10 Measure V_{RF} and V_{COMP} on the digital multimeters. These V_{RF} and V_{COMP} are equivalent to V_{RF0} and V_{COMP0} . Calculate V_0 , which is equivalent to $V_{COMP0} - V_{RF0}$.
- 11 Turn on or reconnect the RF power to the sensor.
- 12 Measure V_{RF} and V_{COMP} on the digital multimeters. These V_{RF} and V_{COMP} are equivalent to V_{RF1} and V_{COMP1} . Calculate V_1 , which is equivalent to $V_{COMP1} - V_{RF1}$.
- 13 Compute the RF power using the following equation:

$$P = \frac{2(V_{COMP1}V_1 - V_{COMP0}V_0) + V_0^2 - V_1^2}{4R\epsilon}$$

Voltage Standing Wave Ratio (VSWR) Measurement

This section describes how to measure the VSWR of a source which is the reference oscillator/power reference connector on a power meter-under-test.

When RF power is transferred from a source to a load, the level of power absorbed by the load, P_A , is dependent on the respective impedance of the load and the respective output impedance of the source. This can be expressed in terms of voltage reflection coefficients (VRCs) as follows:

$$P_A = P_{ZO} \times \frac{1 - |\Gamma_L|^2}{|1 - \Gamma_S \Gamma_L|^2}$$

where:

- P_{ZO} is the power that the source will deliver to a matched load.
- Γ_S and Γ_L are the VRCs of the source and load respectively.

This method for measuring the source match exploits this relationship by presenting the source with two different values of Γ_L and measuring the power delivered to the load under the two conditions. The load used is a thermistor sensor that can be operated at two different resistances of 100 Ω and 200 Ω and can accurately measure the power absorbed. The Agilent 478A thermistor sensor with Option H63, Option H75, or Option H76 normally operates at a DC resistance of 200 Ω giving an RF impedance of 50 Ω and Γ_L close to zero. When the thermistor bridge is set to 100 Ω , the RF impedance is 25 Ω giving a nominal Γ_L of 0.33. The correction factor/effective efficiency of the sensor remains constant under these two conditions so that the power ratio between operation at 200 Ω and 100 Ω can be accurately measured.

If the two reflection coefficients are Γ_1 and Γ_2 and these give the power measurements of P_1 and P_2 respectively (but the available power remains the same) then the two relationships can be equated as follows:

$$P_1 \frac{|1 - \Gamma_S \Gamma_1|^2}{1 - |\Gamma_1|^2} = P_2 \frac{|1 - \Gamma_S \Gamma_2|^2}{1 - |\Gamma_2|^2}$$

Therefore:

$$\frac{P_1(1-|\Gamma_2|^2)}{P_2(1-|\Gamma_1|^2)} = \frac{|1-\Gamma_s\Gamma_2|^2}{|1-\Gamma_s\Gamma_1|^2}$$

The left side of the equation can be replaced by the factor M as follows:

$$\sqrt{M} = \frac{|1-\Gamma_s\Gamma_2|}{|1-\Gamma_s\Gamma_1|}$$

This cannot be directly solved for Γ_s because it is a complex quantity. To solve for Γ_s , additional values of load reflection coefficient are required with a phase difference of approximately 120° . However, an approximate solution using two values of Γ_L can give adequately accurate results provided the phase angle of the source is within $\pm 40^\circ$ of 0° or $\pm 180^\circ$.

The following procedure describes how to measure the VSWR of a source.

- 1 Preset the N432A to its default state by pressing .
- 2 Connect a thermistor sensor to the channel A input connector of the N432A.
- 3 A message will appear to inform you of the current bridge resistance value and require you to select a new resistance value or reconfirm the current resistance value. Use the softkeys to select a value of 200 Ω .
- 4 You will then be prompted for confirmation to proceed with zeroing. Press **Confirm** to proceed.
- 5 Another message will appear, prompting you to confirm whether the sensor has been disconnected from the RF source. Press **Confirm** once you have verified that there is no RF source connected.
- 6 Zeroing will start automatically. The Zeroing pop-up message will be displayed during the zeroing process.
- 7 Set up the following connections shown in [Figure 2-45](#). The network analyzer is used to measure the S_{11} parameter which is equivalent to the reflection coefficient of the thermistor sensor.

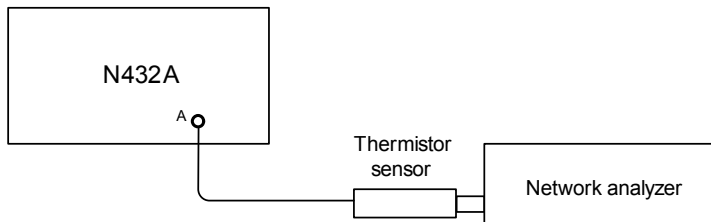









Figure 2-45 Connection diagram for VRC measurement

- 8 Measure the S_{11} parameter on the network analyzer. The S_{11} parameter is equivalent to the reflection coefficient of the sensor, Γ_1 . Record the VRC magnitude of the sensor, $|\Gamma_1|$, which is an absolute value of the reflection coefficient.
- 9 Set the bridge resistance to 100 Ω by pressing  and using the up/down arrow key to highlight the **Bridge Resistance** value field. Press  to display the Bridge Resistance pop-up list and use the up/down arrow key to highlight **100 ohm**, then press  to enter the value.
- 10 Again, measure the S_{11} parameter on the network analyzer, which is now equivalent to Γ_2 . Record the value of $|\Gamma_2|$.
- 11 Set the bridge resistance back to 200 Ω and power off the N432A. Disconnect the sensor from the N432A.
- 12 Now, use a digital voltmeter (DVM) to measure resistance. Connect a DVM between the N432A rear panel V_{RF} output connector and pin 1 on the thermistor mount end of the sensor cable. Verify that no power is applied to the N432A.
- 13 Round off the DVM reading to two decimal places. Record this value as the first internal bridge resistance, R_1 , of the N432A.
- 14 Power on the N432A and set the bridge resistance to 100 Ω . Then, power off the N432A.
- 15 Round off the DVM reading to two decimal places. Record this value as the second internal bridge resistance, R_2 , of the N432A.

- 16** Power on the N432A again and connect the sensor to channel A. A message will appear to inform you of the current bridge resistance value and require you to select a new resistance value or reconfirm the current resistance value. Use the softkeys to select a value of 200 Ω .
- 17** You will then be prompted for confirmation to proceed with zeroing. Press **Confirm** to proceed.
- 18** Another message will appear, prompting you to confirm whether the sensor has been disconnected from the RF source. Press **Confirm** once you have verified that there is no RF source connected.
- 19** Zeroing will start automatically. The Zeroing pop-up message will be displayed during the zeroing process.
- 20** Enable the sensor calibration table by pressing  > **Offsets**, then using the up/down arrow key to highlight the **CF Table** setting field, and pressing  to display the tables. Use the up/down arrow key to select the required table and press **Table** to highlight **On**. Press **Done** >  to complete the table selection and return to the channel setup screen.
- 21** Enter the frequency of the RF signal you are measuring by using the up/down arrow key to highlight the **Frequency** setting field, and pressing . Use the numeric keypad to enter the required value in the Frequency pop-up, then press either **MHz** or **GHz**. The N432A will automatically select and apply the calibration factor from the selected table based on the entered frequency. Press  > **Offsets** to check the calibration factor value on the **Cal Fac** setting field.
- 22** Now, set up the connections shown in [Figure 2-46](#). Connect the N432A rear panel V_{RF} output connector to the negative input lead of DVM 1. Connect the N432A rear panel V_{COMP} output connector to the positive input leads of both DVMs.

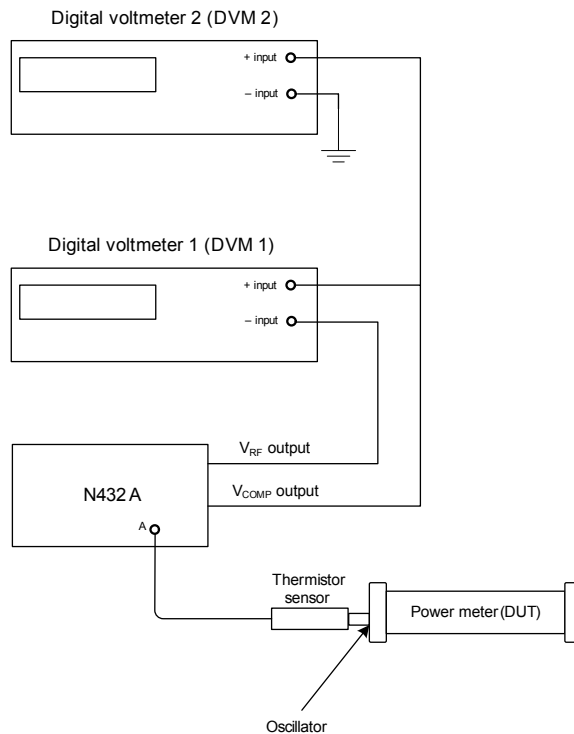

Figure 2-46 Connection diagram for VSWR measurement

NOTE

Prior to proceeding with the following steps, ensure that the N432A and the power meter-under-test have been switched on for at least 30 minutes.

- 23** Preset the power meter-under-test. Ensure that its oscillator/power reference is turned off.
- 24** Set the DVMs to measure microvolts.
- 25** Round off the value of DVM 1 to two decimal places. Record this value as V_0 . Observe the reading on DVM 2 and record the value as V_{COMP0} .
- 26** Turn on the oscillator/power reference of the power meter-under-test.
- 27** Round off the value of DVM 1 to two decimal places. Record this value as V_1 . Observe the reading on DVM 2 and record the value as V_{COMP1} .

28 Compute the power measured from the oscillator, P_1 , using the following equation:

$$P_1 = \frac{2(V_{COMP1}V_1 - V_{COMP0}V_0) + V_0^2 - V_1^2}{4R_1}$$

29 Now, set the N432A bridge resistance to 100 Ω . Again, set up the connections shown in [Figure 2-46](#).

30 Repeat steps 26 to 28.

31 Compute the power measured from the oscillator, P_2 , using the following equation:

$$P_2 = \frac{2(V_{COMP1}V_1 - V_{COMP0}V_0) + V_0^2 - V_1^2}{4R_2}$$

32 Compute factor M using the following equation:

$$M = \frac{P_1(1 - |\Gamma_2|^2)}{P_2(1 - |\Gamma_1|^2)}$$

33 Compute the value of the output VRC, $|\Gamma_s|$, using the following equation:

$$|\Gamma_s| = \frac{(2|\Gamma_1|M - 2|\Gamma_2|) \pm \sqrt{(2|\Gamma_2| - 2|\Gamma_1|M)^2 - 4(|\Gamma_1|^2M - |\Gamma_2|^2)(M - 1)}}{2(|\Gamma_1|^2M - |\Gamma_2|^2)}$$

One of the roots of this equation will be non-physical while the other gives a value for $|\Gamma_s|$.

34 Finally, VSWR of the source can be computed as follows:

$$VSWR = \frac{(1 + |\Gamma_s|)}{(1 - |\Gamma_s|)}$$

Blank Screen

The blank screen feature enables you to blank the whole display screen. This feature ensures that the N432A display is not shown to casual observers.

To restore the display, press any key on the front panel.

To access this feature, press  > **1 of 2** and select **Service**. On the **Service** menu, press **1 of 2** and select **Display**. Press **Blank Screen**.

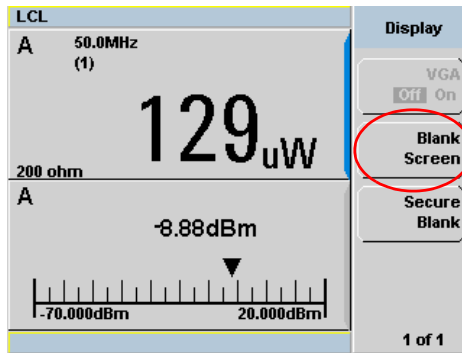

Figure 2-47 Blank Screen feature

Secure Blank

The secure blank feature is the next level of security to the blank screen feature. Data confidentiality can be secured using this password-protection feature. To restore the display, you are required to enter the correct password.

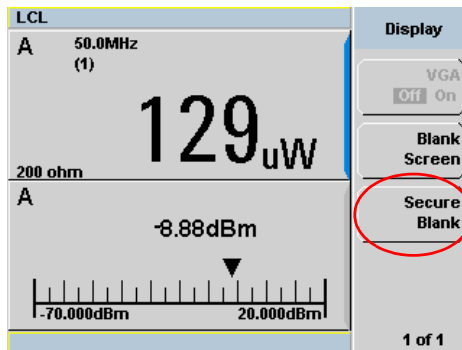

Figure 2-48 Secure Blank feature

Procedure

Use the following steps to access the secure blank feature.

- 1 Press **System** > **1 of 2** and select **Service**.
- 2 On the **Service** menu, press **1 of 2** and select **Display**.
- 3 Press **Secure Blank**. The Enter 6-digit Password pop-up will appear as shown in [Figure 2-49](#). You need to enter a 6-digit password upon activating the secure blank feature.

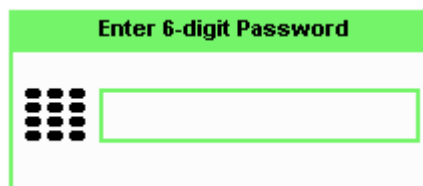

Figure 2-49 Enter 6-digit Password pop-up

2 Operating Information

- 4 Press **Enter** once you have entered the password.
- 5 If the entered password is not made up of six digits, a warning message will appear as shown below. This warning will appear for two seconds before the enter password pop-up (Figure 2-49) re-appears.



Figure 2-50 Warning message

- 6 Once you have entered a valid password, the Reconfirm Password pop-up will appear as shown below. You need to enter the password again for confirmation.

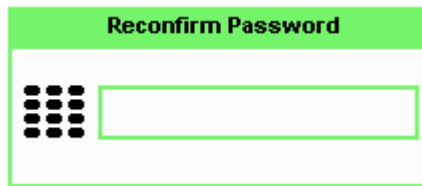

Figure 2-51 Reconfirm Password pop-up

- 7 If the password entered is different from the initial password, a warning message will appear as shown in Figure 2-52. This warning will appear for two seconds before the Reconfirm Password pop-up (Figure 2-49) re-appears.



Figure 2-52 Warning message

- 8 When the correct password is successfully entered for the second time, you will be prompted for confirmation before the screen is blanked. Press **Confirm**.

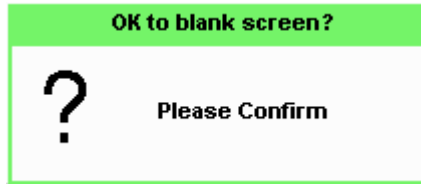

Figure 2-53 Password reconfirmation pop-up

- 9 Once the screen is blanked, pressing any of the front panel keys will prompt you to enter the password to restore the display (Figure 2-54). You are only allowed up to three attempts of password entry.

Upon an unsuccessful third attempt, you will need to wait for two hours with the N432A powered on before you can re-enter the password. You are then allowed up to three attempts of password entry again. The whole cycle of password entry will then be repeated.

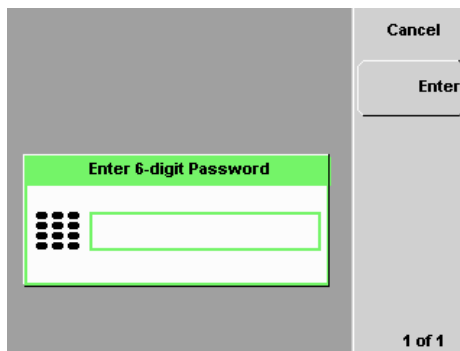

Figure 2-54 Password required to restore display

NOTE

If you have forgotten the 6-digit password and need to operate the N432A immediately, perform the Memory Erase operation. This operation will erase all data stored in the N432A. Refer to “[Memory Erase/Secure Erase](#)” on page 93 for more details.

Backlight Intensity Control

The backlight intensity control allows you to increase or decrease the backlight brightness.

To access this feature, press **System** > **1 of 2** and select **Service**. On the **Service** menu, press **1 of 2** and select **Backlight**.

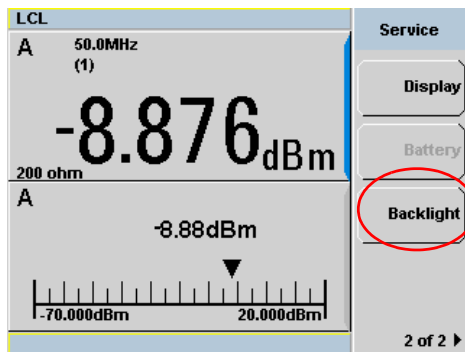

Figure 2-55 Backlight intensity control feature

Press **Brightness +** to increase the backlight brightness.

Press **Brightness -** to decrease the backlight brightness.

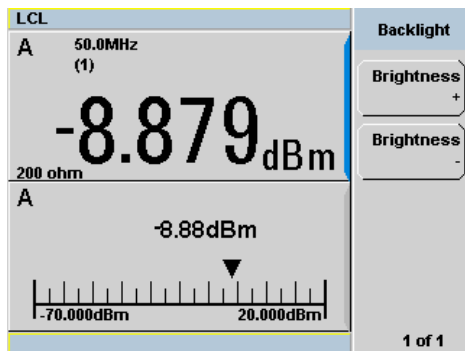

Figure 2-56 Increase or decrease the backlight brightness

Memory Erase/Secure Erase

The memory erase and secure erase features will erase the SRAM and flash file system. The flash file system includes the N432A states, calibration factor tables, frequency-dependent offset tables, and a secure blank password stored in EEPROM. Upon completion, the N432A contents will be initialized to the default settings. These features can only be activated via the front panel.

The memory erase feature can be invoked if you forget the 6-digit password set during secure blank.

To perform memory erase/secure erase, use one of the following procedures:

Memory erase

- 1 Simultaneously press and hold both the fourth softkey from the top and



before power on, as shown below.

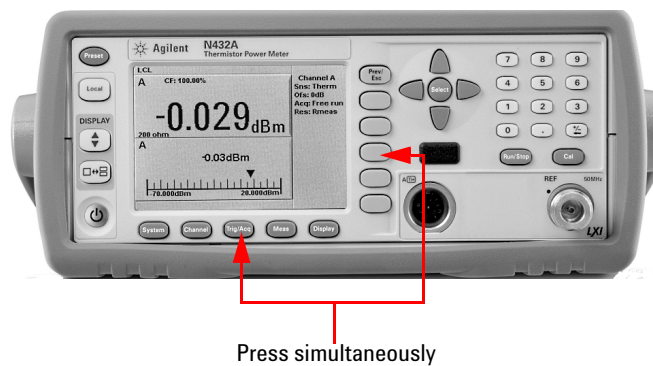

Figure 2-57 Activate memory erase using combo keys

- 2 During memory erase, the splash screen will display **“Clearing Memory...”**. When memory erase has completed, **“Clearing Memory...done”** will be displayed.

Secure erase

- 1 Press **System** > **1 of 2** and select **Service**. On the **Service** menu, select **Secure Erase** as shown below.

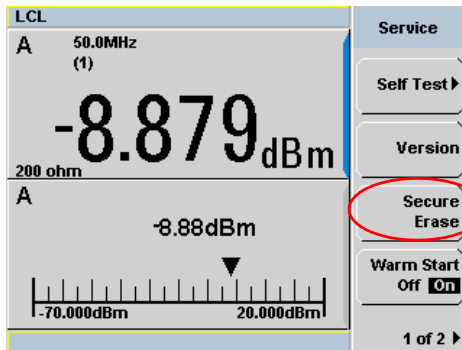

Figure 2-58 Secure Erase feature

- 2 A confirmation pop-up dialog will appear as shown below. Press **Confirm** to begin secure erase.

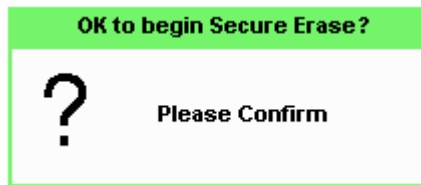

Figure 2-59 Confirmation to begin secure erase

- 3 The following warning message will appear to inform you of the progress status.



Figure 2-60 Warning message displaying the secure erase status

Warm Start

The warm start feature allows you to retain the N432A current states and settings upon power cycle or in the event of interrupted power. The warm start On/Off feature is selectable via the front panel and SCPI. The default setting is On.

Warm start ON

All the current states and settings configured via the front panel or SCPI will be saved. The N432A will be powered on with the states and settings before it was powered off.

Warm start OFF

The N432A will be powered on with the default states and settings.

Procedure

Use the following steps to enable/disable the warm start feature.

- 1 Press **System** > **1 of 2** and select **Service**.
- 2 On the **Service** menu, press **Warm Start** to toggle On/Off the warm start feature as shown below.

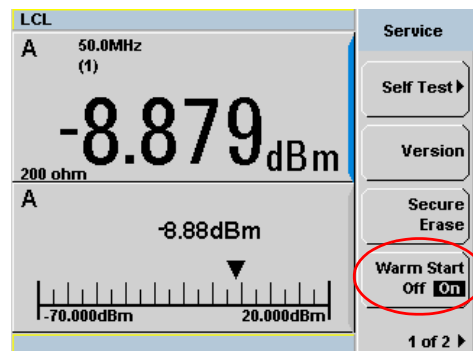

Figure 2-61 Warm start On/Off feature



3 Maintenance

Self-Test	98
Error Messages	103
Operator Maintenance	112
Contacting Agilent Technologies	113
Erasing Memory Data	116
Returning the N432A for Service	117
Agilent Sales and Service Offices	118

This chapter describes the built-in tests, error messages, and general maintenance.



Self-Test

The N432A troubleshooting mode self-test can be accessed via the front panel or remotely. The front panel softkey menu allows you to run individual test, whereas the remote command runs a full instrument self-test as listed in “[Remote testing](#)” on page 101.

Front panel selection of self-tests

Press  > **1 of 2** > **Service** > **Self Test** to access the **Self Test** menu that consists of the following tests:

- Instrument Self-Test
- Keyboard
- Bitmap Displays
- RTC Battery

Instrument self-test

When **Instrument Self Test** is selected, the following tests will be run: (These are the same tests run using the *TST? command.)

- Test Point Voltages
- Calibrator
- Fan
- RTC Battery
- V_{RF} Path
- V_{COMP} Path
- V_0 Path

When **Run Self Test** is pressed, the N432A will check if the thermistor sensor is connected. If connected, you will be prompted to disconnect the sensor.

Once **Confirm** is pressed, the N432A will check if the sensor is disconnected. If disconnected, self-test will initiate and display the test results accordingly.

As each test takes place, the name of the test is listed on the screen. While a test is running, the message **Testing...** appears beside the name of the test. As each stage of the test completes, the **Testing...** message is replaced by either **Passed** or **Failed**.

LCL		Self Test
TEST	RESULT	
Test Point Voltages	Passed	
Calibrator	Passed	
Fan	Passed	
RTC Battery	Passed	
Vrf Path	Passed	
Vcomp Path	Passed	
V0 Path	Passed	
		Done

Figure 3-1 Self-test completed

When the self-test has completed, press **Done** to return to the **Self Test** menu.

If the self-test failed, information about the failure will be displayed on the screen.

For any currently selected bridge resistance value of either 100 Ω , 200 Ω , 300 Ω , or 400 Ω , the internal self-test resistance value of 200 Ω will be used to perform the self-test.

When you press **Run Self Test** followed by **Confirm** even if the sensor is still connected, you will be prompted again to disconnect the sensor. If you cancel the sensor disconnect confirmation with the sensor still connected, tests for V_{RF} , V_{COMP} , and V_0 will be skipped and displayed as shown below.

LCL ERR		Self Test
TEST	RESULT	
Test Point Voltages	Passed	Done
Calibrator	Passed	
Fan	Passed	
RTC Battery	Passed	
Vrf Path (Sensor connected)	Skipped	
Vcomp Path (Sensor connected)	Skipped	
V0 Path (Sensor connected)	Skipped	

Figure 3-2 V_{RF} , V_{COMP} , and V_0 tests skipped

Remote testing

To perform a remote instrument self-test, the IEEE-488.2 common command *TST? is used. This command runs a full self-test and returns one of the following codes:

- 0 – no tests failed
- 1 – one or more tests failed

The communications assembly is tested implicitly, in that the command will not be accepted or return a result unless the remote interface is functioning correctly.

Refer to “[Test descriptions](#)” on page 101 if you require a description of each individual test.

When the *TST? command is executed, the screen is cleared. As each test takes place, the name of the test is listed on the screen. While a test is running, the message **Testing...** appears beside the name of the test. As each stage of the test completes, the message **Testing...** is replaced by either **Passed** or **Failed**.

Test descriptions

This section specifies what is actually checked by each of the tests. Some of the tests may only be applicable to one method of invocation (for example, from the front panel). If this is the case, it is specified in the test description. Most of the tests have an associated error message which is added to the error queue if the test fails. The exception to this is the bitmap display test. Refer to “[Error Messages](#)” on page 103 for more details.

Test Point Voltages

An array of tests on various DC voltages inside the N432A.

Calibrator

The reference calibrator is turned on (indicated by the POWER REF LED) and measured internally. A pass or fail result is returned.

Fan

This test confirms that the internal cooling fan is running.

Real Time Clock (RTC) Battery

The RTC battery provides power for the real-time clock circuitry on the motherboard when the N432A is powered off.

During the RTC battery test, the RTC battery power level is determined by converting the ADC value of the RTC battery power level read from the FPGA, to voltage level. If the battery power level is less than a prespecified threshold (threshold to be defined later), the test will fail. An error will be logged in the error list if the test fails.

V_{RF} , V_{COMP} , V_0 Paths

An array of tests on the voltage metering for V_{RF} , V_{COMP} , and V_0 . The built-in self-test circuit will output a set of known DC voltages to the bridge which are then compared to those measured by the N432A metering. This is a user-invoked self-test.

Error Messages

Introduction

This section contains information on error messages. It explains how to read the N432A error queue and lists all the error messages and their probable causes.

When there is a hardware-related problem, for example, a sensor overload, the error is indicated on the status line at the top of the display. In addition, errors are also written to the error queue. If there is any error in the error queue, the front-panel error indicator is displayed as shown in the figure below.

Other errors can also be generated when the N432A is being operated over the remote interface. These errors also display the error indicator and are written to the error queue.

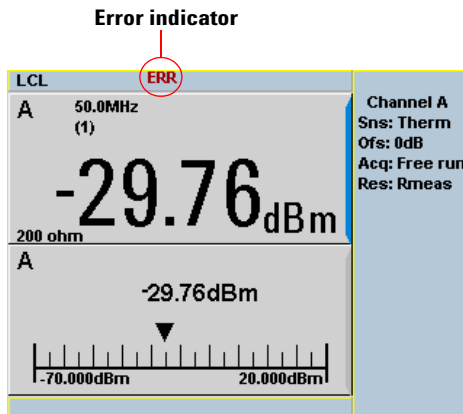



Figure 3-3 Error indicator

To read the error queue from the front panel:

- press  > **Error List** and use **Next** to scroll through each error message.

To read the error queue from the remote interface, use:

- the SYSTem:ERRor? query.

Error queue messages have the following format:

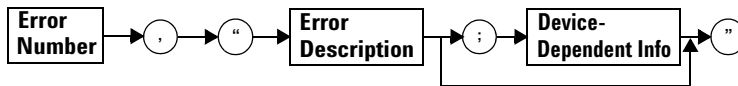

Error queue message

For example, -113,"Undefined header;*T<Err> ST?".

Errors are retrieved in a first-in, first-out (FIFO) order. If more than 30 errors occur, the error queue overflows and the last error in the queue is replaced with error -350,"Queue overflow". Any time the queue overflows, the most recent errors are discarded.

When the errors are read, they are removed from the error queue. This opens a position at the end of the queue for a new error message, if one is subsequently detected. When all errors have been read from the queue, further error queries return +0,"No error".

To delete all the errors in the queue from the front panel:

- press  > **Error List** and use **Clear Errors**.

To delete all the errors in the queue remotely, use:

- the *CLS (clear status) command.

The error queue is also cleared when the N432A power has been switched off.

Error list

-101	<p>Invalid character</p> <p>An invalid character was found in the command string. You may have inserted a character such as #, \$, or % in the command header or within a parameter.</p> <p>Example: LIM:LOW 0#</p>
-102	<p>Syntax error</p> <p>Invalid syntax was found in the command string</p> <p>Example: LIM:CLE:AUTO, 1 or LIM:CLE: AUTO 1</p>
-103	<p>Invalid separator</p> <p>An invalid separator was found in the command string. You may have used a comma instead of a colon, semicolon, or blank space; or you may have used a blank space instead of a comma.</p> <p>Example: OUTP:ROSC,1</p>
-105	<p>GET not allowed</p> <p>A Group Execute Trigger (GET) is not allowed within a command string</p>
-108	<p>Parameter not allowed</p> <p>More parameters were received than expected for the command. You may have entered an extra parameter, or added a parameter to a command that does not accept a parameter.</p> <p>Example: CAL 10</p>
-109	<p>Missing parameter</p> <p>Fewer parameters were received than expected for the command. You may have omitted one or more parameters that are required for this command.</p> <p>Example: AVER:COUN:VOLT</p>
-112	<p>Program mnemonic too long</p> <p>A command header was received which contained more than the maximum 12 characters allowed</p> <p>Example: SENSEAVERageCOUNtVOLTage AVC8</p>

-113	Undefined header
	A command was received that is not valid for the N432A. You may have misspelled the command, it may not be a valid command, or you may have selected the wrong interface. If you are using the short form of the command, remember that it may contain up to four letters. Example: TRIG:SOU IMM
-121	Invalid character in number
	An invalid character was found in the number specified for a parameter value Example: SENS:BRES R100#H
-123	Exponent too large
	A numeric parameter was found whose exponent was larger than 32000 Example: CAL:RCF 1E34000
-124	Too many digits
	A numeric parameter was found whose mantissa contained more than 255 digits, excluding leading zeros
-128	Numeric data not allowed
	A numeric value was received within a command which does not accept a numeric value Example: MEM:CLE 24
-131	Invalid suffix
	A suffix was incorrectly specified for a numeric parameter. You may have misspelled the suffix. Example: SENS:FREQ 200KZ
-134	Suffix too long
	A suffix used contained more than 12 characters Example: SENS:FREQ 2MHZZZZZZZZZZ
-138	Suffix not allowed
	A suffix was received following a numeric parameter which does not accept a suffix Example: INIT:CONT 0Hz

-148	Character data not allowed
	A discrete parameter was received but a character string or a numeric parameter was expected. Check the list of parameters to verify that you have used a valid parameter type. Example: MEM:CLE CUSTOM_1
-151	Invalid string data
	An invalid string was received. Check to see if you have enclosed the character string in single or double quotes. Example; MEM:CLE "CUSTOM_1
-158	String data not allowed
	A character string was received but is not allowed for the command. Check the list of parameters to verify that you have used a valid parameter type. Example: LIM:STAT 'ON'
-161	Invalid block data
	A block data element was expected but was invalid for some reason, for example, *DDT #15FET. The 5 in the string indicates that five characters should follow, whereas in this example there are only three.
-168	Block data not allowed
	A legal block data element was encountered but not allowed by the N432A at this point Example: SYST:COMM:GPIB:ADDR #15FETC?
-178	Expression data not allowed
	A legal expression data was encountered but not allowed by the N432A at this point Example: FORM:BORD (5+2)
-211	Trigger ignored
	Indicates that <GET> or *TRG, or TRIG:IMM was received and recognized by the device but was ignored because the N432A was not in the wait-for-trigger state

-213	<p>Init ignored</p> <p>Indicates that a request for a measurement initiation was ignored as the N432A was already initiated</p> <p>Example: INIT:CONT ON INIT</p>
-214	<p>Trigger deadlock</p> <p>TRIG:SOUR was set to HOLD or BUS and a READ? or MEASure? was attempted, expecting TRIG:SOUR to be set to IMMEDIATE</p>
-220	<p>Parameter error; Frequency list must be in ascending order</p> <p>Indicates that the frequencies entered using the MEMory:TABLE:FREQuency command are not in the ascending order</p>
-221	<p>Settings conflict</p> <p>This message occurs under a variety of conflicting conditions. The following list gives a few examples of where this error may occur:</p> <ul style="list-style-type: none">• If the READ? parameters do not match the current settings• Trying to clear a sensor calibration table when none is selected
-222	<p>Data out of range</p> <p>A numeric parameter value is outside the valid range for the command</p> <p>Example: SENS:FREQ 2 HZ</p>
-224	<p>Illegal parameter value</p> <p>A discrete parameter was received which was not a valid choice for the command. You may have used an invalid parameter choice.</p> <p>Example: TRIG:SOUR EXT</p>
-226	<p>Lists not same length</p> <p>This occurs when SENSE:CORREction:CSET[1] CSET2:STATE is set to ON and the frequency and calibration/offset lists do not correspond in length</p>
-230	<p>Data corrupt or stale</p> <p>This occurs when a FETC? is attempted and either a reset has been received or the N432A state has changed such that the current measurement is invalidated (for example, a change of frequency setting or triggering conditions)</p>

-231	Data questionable;Input Overload The power input to the channel exceeds the maximum range of the sensor
-231	Data questionable;Input Overload ChA The power input to Channel A exceeds the maximum range of the sensor
-231	Data questionable;Lower window log error This indicates that a difference measurement in the lower window has given a negative result when the units of measurement were logarithmic
-231	Data questionable;Upper window log error This indicates that a difference measurement in the upper window has given a negative result when the units of measurement were logarithmic
-231	Data questionable;ZERO ERROR N432A zeroing failed. The most likely cause is attempting to zero when some power signal is being applied to the sensor.
-231	Data questionable;ZERO ERROR ChA N432A zeroing failed on Channel A. The most likely cause is attempting to zero when some power signal is being applied to the sensor.
-231	Data questionable;Measurement Over Range The voltage measurement failed as the measured data has exceeded the maximum range
-231	Data questionable;Measurement Under Range The voltage measurement failed as the measured data is below the minimum range
-241	Hardware missing The N432A is unable to execute the command because either no sensor is connected or it expects a compatible thermistor sensor and one is not connected

-310	System error This indicates that there is a problem with the N432A operation. This error may occur under certain conditions, for example, the front panel backlight is not turned on when you set the backlight intensity or there is no non-volatile RAM on board when you configure the warm start state.
-321	Out of memory The N432A required more memory than was available to run an internal operation
-330	Self-test Failed; The -330, "Self-test Failed" errors indicate that you have a problem with your N432A. Refer to " Contacting Agilent Technologies " on page 113 for details on how to manage your faulty N432A.
-330	Self-test Failed; Measurement Channel Fault
-330	Self-test Failed; Measurement Channel A Fault
-330	Self-test Failed; Calibrator Fault Refer to " Calibrator " on page 101 if you require a description of the calibrator test
-330	Self-test Failed; ROM Check Failed
-330	Self-test Failed; RAM Check Failed
-350	Queue overflow The error queue is full and another error has occurred which could not be recorded
-361	Parity error in program The serial port receiver has detected a parity error and consequently, data integrity cannot be guaranteed
-362	Framing error in program The serial port receiver has detected a framing error and consequently, data integrity cannot be guaranteed

-363	Input buffer overrun The serial port receiver has been overrun and consequently, data has been lost
-410	Query INTERRUPTED A command which sends data to the output buffer was received, but the output buffer contained data from a previous command (the previous data was not overwritten). The output buffer was cleared when power has been turned off, or after a *RST (reset) command has been executed.
-420	Query UNTERMINATED The N432A was addressed to talk (that is, to send data over the interface) but a command which sends data to the output buffer has not been received. For example, you may have executed a CONFigure command (which does not generate data) and then attempted to read data from the remote interface.
-430	Query DEADLOCKED A command was received which generates too much data to fit in the output buffer and the input buffer is also full. Command execution continues but data is lost.
-440	Query UNTERMINATED after indefinite response The *IDN? query must be the last query within a command string

Operator Maintenance

This section describes how to replace the power line fuses and clean the N432A. If you need additional information on replacing parts or repairing the N432A, refer to the *N432A Thermistor Power Meter Service Guide*.

To clean the N432A, disconnect its power supply and wipe the outer panels with a soft, lint-free, slightly dampened cloth. Do not use detergent. Disassembly is not required or recommended for cleaning.

The power line fuses are located within the N432A fuse holder assembly on the rear panel. For all voltages, the N432A uses 250 V, T2.5 H, 20 mm slow blow fuses with high breaking capacity.

Checking the power line fuses

- 1 Slide the fuse holder assembly from the rear panel as shown in the figure below.
- 2 The fuses should be positioned “in line” as shown below. Ensure that both fuses are operational.
- 3 Slide the fuse holder assembly back into the rear panel.

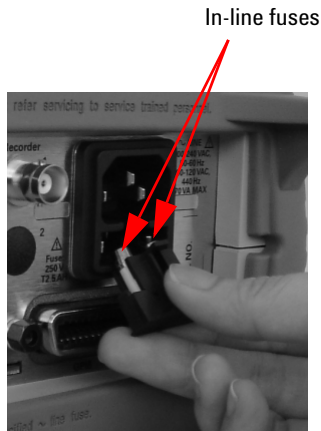

Figure 3-4 Checking the fuses

Contacting Agilent Technologies

This section provides the information on what to do if you encounter problems with your N432A.

First, refer to the section “[Prior to contacting Agilent Technologies](#)”. This chapter contains a checklist that will help identify some of the most common problems.

If you wish to contact Agilent Technologies to enquire about the N432A, from service problems to ordering information, refer to “[Agilent Sales and Service Offices](#)” on page 118.

If you wish to return the N432A to Agilent Technologies, refer to “[Returning the N432A for Service](#)” on page 117.

Prior to contacting Agilent Technologies

Before calling Agilent Technologies or returning the N432A for service, perform the inspection based on the list in “[Check the basics](#)” on page 114. If you still encounter problems, read the warranty printed at the front of this guide. If your N432A is covered by a separate maintenance agreement, familiarize yourself with the terms.

Agilent Technologies offers several maintenance plans to service your N432A after warranty expiration. Call your Agilent Technologies Sales and Service Center for full details.

Check the basics

Problems can be solved by repeating what was being performed when the problem occurred. A few minutes spent in performing these simple inspections may eliminate time spent waiting for instrument repair. Before calling Agilent Technologies or returning the N432A for service, make the following inspections:

- Check that the line socket has power.
- Check that the N432A is plugged into a proper AC power source.
- Check that the N432A is switched on.
- Check that the line fuses are in good working condition.
- Check that other equipment, cables, and connectors are connected properly and operating correctly.
- Check the equipment settings in the procedure that was being used when the problem occurred.
- Check that the test being performed and the expected results are within the specifications and capabilities of the N432A.
- Check the N432A display for error indicators.
- Check the N432A operation by performing self-tests.
- Check using a different thermistor sensor.

Instrument serial numbers

Agilent Technologies makes frequent improvements to its products to enhance their performance, usability, and reliability. Agilent Technologies service personnel have access to complete records of design changes for each instrument. The information is based on the serial number and option designation of each N432A.

Whenever you contact Agilent Technologies about your N432A, have a complete serial number available. This ensures you obtain the most complete and accurate service information. The serial number can be obtained via the following:

- querying the N432A over the remote interface using the *IDN? command.
- from the front panel by pressing  > **1 of 2** > **Service** > **Version**.
- from the serial number label.

The serial number label is attached to the rear panel of each Agilent Technologies instrument. This label has two instrument identification entries. The first provides the instrument serial number and the second provides the identification number for each option built into the instrument.

The serial number is divided into two parts: the prefix (two letters and the first four numbers), and the suffix (the last four numbers).

- The prefix letters indicate the country of manufacture. This code is based on the ISO international country code standard, and is used to designate the specific country of manufacture for the individual product. The same product number could be manufactured in two different countries. In this case, the individual product serial numbers would reflect different country of manufacture codes. The prefix also consists of four numbers. This is a code identifying the date of the last major design change.
- The suffix indicates an alphanumeric code which is used to ensure unique identification of each product throughout Agilent Technologies.

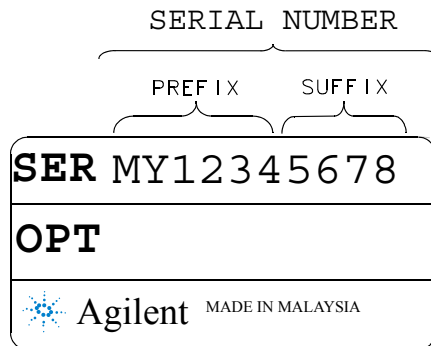

Recommended calibration interval

Agilent Technologies recommends a one-year calibration cycle for the N432A.

Erasing Memory Data

This section explains how to erase the N432A memory, for example, before you return the N432A to Agilent Technologies for repair or calibration, of all data stored in it which includes the save/recall and last power-on states.

Use the following procedure to erase the memory data.

- 1 Press  > **1 of 2**.
- 2 Press **Service** followed by **Secure Erase**.
- 3 Press **Confirm** to begin secure erase.
- 4 The following warning message will appear, informing you of the progress status.



Figure 3-5 Secure erase status pop-up

Returning the N432A for Service

Use the information in this section if you need to return your N432A to Agilent Technologies.

Packaging the N432A for shipment

Use the following procedure to package the N432A for shipment to Agilent Technologies for servicing:

- Be as specific as possible about the nature of the problem. Send a copy of any or all of the following information:
 - Any error messages that appeared on the N432A display.
 - Any information on the performance of the N432A.

CAUTION

Damage to the instrument can result from using packaging material other than those specified. Never use styrene pellets in any shape as packaging material. They do not adequately cushion the instrument or prevent it from shifting in the carton. Styrene pellets cause instrument damage by generating static electricity and by lodging in the rear panel.

- Use the original packaging material or a strong shipping container made of double-walled, corrugated cardboard with 91 kg (200 lb.) bursting strength. The carton must be large and strong enough to accommodate the N432A and allow at least 3 to 4 inches on all sides of the N432A for packing material.
- Surround the N432A with at least 3 to 4 inches of packing material, or enough to prevent the N432A from moving in the carton. If packing foam is not available, the best alternative is SD-240 Air Cap™ from Sealed Air Corporation (Commerce, CA 90001). Air Cap looks like a plastic sheet covered with 1-1/4-inch air filled bubbles. Use the pink Air Cap to reduce static electricity. Wrap the N432A several times in the material as protection and to prevent it from moving in the carton.
- Seal the shipping container securely with strong nylon adhesive tape.
- Mark the shipping container as “FRAGILE, HANDLE WITH CARE” to ensure careful handling.
- Retain copies of all shipping papers.

Agilent Sales and Service Offices

In any correspondence or telephone conversations, refer to the N432A by its model number and full serial number. With this information, the Agilent representative can quickly determine whether your unit is still within its warranty period.

UNITED STATES	Agilent Technologies (tel) (800) 829 4444
CANADA	Agilent Technologies Canada Inc. Test & Measurement (tel) (877) 894 4414
EUROPE	Agilent Technologies Test & Measurement European Marketing Organization (tel) 31 20 547 2111
JAPAN	Agilent Technologies Japan Ltd. (tel) 0120 (421) 345 (fax) 0120 421 678
LATIN AMERICA	Agilent Technologies Latin America Region Headquarters, USA (tel) 305 269 7500
AUSTRALIA and NEW ZEALAND	Agilent Technologies Australia Pty Ltd. (tel) 61 3 9210 5555 (Australia) (fax) 61 3 9210 5899 (Australia) (tel) (408) 345 8886 (New Zealand) (fax) (408) 345 8474 (New Zealand)
ASIA PACIFIC	Agilent Technologies, Hong Kong (tel) (852) 3197 7777 (fax) (852) 2506 9292

Or visit Agilent's Web site at www.agilent.com/find/assist.



4 Specifications and Characteristics

Introduction	120
N432A Specifications	122
Rear Panel Input and Output Connections	124
1 mW Power Reference	125
Environmental Conditions	126
Physical Characteristics	127
Regulatory Information	128

This chapter describes the specifications and characteristics of your N432A.



Introduction

This chapter details the N432A specifications and supplemental characteristics.

Specification definitions

There are two types of product specifications:

- Warranted specifications
- Characteristic specifications

Warranted specifications

Warranted specifications are covered by the product warranty and applied after a 30-minute warm-up. These specifications are valid over the N432A operating and environmental ranges unless otherwise stated, and after performing zeroing.

Characteristic specifications

Supplemental characteristics which are specified in italics are intended to provide information useful in applying to the N432A by giving typical, but non-warranted performance parameters. These characteristics are specified in *italics* or denoted as “*typical*”, “*nominal*”, or “*approximate*”.

Characteristic information is representative of the product. In many cases, it may also be supplemental to a warranted specification. Characteristic specifications are not verified on all products. The types of characteristic specifications can be placed in two groups:

- The first group of characteristic types describes 'attributes' common to all products of a given model or option.

Examples of characteristics that describe 'attributes' are product weight and 50 Ω input Type-N connector. In these examples, the product weight is an *approximate* value and the 50 Ω input is *nominal*. These two terms are most widely used when describing 'attributes' of a product.

- The second group of characteristic types describes 'statistically' the aggregate performance of the population of products.

These characteristics describe the expected behavior of the population of products. They do not guarantee the performance of any individual product. No measurement uncertainty value is accounted for in the specifications. These specifications are referred to as *typical*.

Conditions

The N432A with a thermistor sensor meet its specifications when:

- stored for a minimum of two hours at a stable temperature within the operating temperature range, and turned on for at least 30 minutes.
- the N432A and the thermistor sensor are within their recommended calibration periods.
- used in accordance to the information provided in this guide.

N432A Specifications

Frequency range

100 kHz to 18 GHz, thermistor-sensor dependent

Power range

-30 dBm to +10 dBm (1 μ W to 10 mW), thermistor-sensor dependent

Thermistor sensor compatibility

- Agilent 478A thermistor sensor (with Option H63, H75, and H76)
- Agilent 8478B thermistor sensor

Meter power accuracy

Absolute power accuracy: \pm (0.1% of reading + 0.5 μ W)

Meter voltage accuracies (1-year reference specifications)

- V_{RF} and V_{COMP} : $23^{\circ}\text{C} \pm 5^{\circ}\text{C}$: $\pm(0.0035\% + 50 \mu\text{V})$ [reading + range]
- V_0 and V_1 : $23^{\circ}\text{C} \pm 5^{\circ}\text{C}$: $\pm(0.0040\% + 25 \mu\text{V})$ [reading + range]

Bridge resistance

Selectable resistances of 100, 200, 300, and 400 Ω

Single sensor dynamic range

40 dB maximum (Agilent 478A and 8478B thermistor sensors)

Display units

- Power: Absolute – Watts (W) or dBm, Relative – Percent (%) or dB
- V_{RF} and V_{COMP} : VDC
- V_0 and V_1 : VDC and mVDC
- Bridge resistance: Ohm

Display resolutions

- Power: Selectable resolutions of 1, 0.1, 0.01, and 0.001 dBm in logarithmic mode, or 1, 2, 3, and 4 significant digits in linear mode

- Voltage: 6.5-digit resolution
- Bridge resistance: 6.5-digit resolution

Default resolution

0.01 dBm in logarithmic mode or three significant digits in linear mode

Rear Panel Input and Output Connections

Recorder output	Analog 0 to 1 V, 1 k Ω output impedance, BNC connector
GPIB USB 2.0 10/100 BaseT LAN	These interfaces allow communication with an external controller
V_{RF} and V_{COMP} outputs	BNC terminals which output the RF and compensation bridge voltages that can be used for precision power measurements
Ground	Binding post, accepts 4 mm plug or bare wire connection

Line power

Input voltage range	100 – 240 Vac, automatic selection 220 – 240 V \pm 10%
Input frequency range	50 – 60 Hz, 400 Hz 400 Hz (100 – 120 Vac)
Power requirement	70 VA

1 mW Power Reference

Power output	1.00 mW (0.0 dBm)
Accuracy	$\pm 1.2\%$ (0 – 45°C) $\pm 0.4\%$ (25 \pm 10°C)
Frequency	50 MHz nominal
SWR	1.06 maximum
Connector type	Type N (f), 50 Ω

Environmental Conditions

General

The N432A complies with the requirements of the EMC Directive 89/336/EEC. The N432A is designed for indoor use only.

Operating environment

Operating temperature	0°C to 45°C
Operating humidity	15% to 95% at 40°C (non-condensing)
Altitude	Up to 4600 m (15000 ft.)

Storage

Storage temperature	-40°C to +70°C
Storage humidity	Up to 90% relative humidity at 65°C (non-condensing)

Physical Characteristics

Dimensions

The following dimensions exclude front and rear panel protrusions:

- 212.6 mm W x 88.5 mm H x 348.3 mm D
(8.5 in x 3.5 in x 13.7 in)

Weight

Weight (net)	≤ 3.70 kg (approximately)
Weight (shipping)	≤ 8.30 kg (approximately)

Regulatory Information

Electromagnetic (EM) compatibility

The N432A complies with the essential requirements of the following applicable European (EC) Directives, and carries the CE marking accordingly to the Low Voltage Directive (2006/95/EC) and EMC Directive (2004/108/EC).

EMC tests conform to the IEC 61326-2-1:2005/EN 61326-2-1:2006 and CISPR 11:2003/EN 55011:2007 (Group 1, Class A). In order to preserve the EMC performance of the N432A, any cable which becomes worn or damaged must be replaced with the same type and specification.

The N432A also meets the following EMC standards:

- Canada: ICES-001:2004
- Australia/New Zealand: AS/NZS CISPR11:2004

Degradation of some instrument specifications can occur in the presence of ambient EM fields and noise that are coupled to the power line or I/O cables of the N432A. The N432A will self-recover and operate to all specifications when the source of ambient EM fields and noise are removed or when the N432A is protected from the ambient EM fields or when the N432A cabling is shielded from the ambient EM noise.

Product safety

The N432A conforms to the requirements of the following safety standards:

- IEC 61010-1:2001/EN 61010-1:2001
- CAN/CSA-C22.2 No.61010-1-04
- ANSI/UL61010-1:2004

Low voltage directive

The N432A conforms to the requirements of the European Council Directive "2006/95/EC".

4 Specifications and Characteristics

www.agilent.com

Contact us

To obtain service, warranty, or technical assistance, contact us at the following phone or fax numbers:

United States:

(tel) (800) 829 4444 (fax) 800 829 4433

Canada:

(tel) (877) 894 4414 (fax) 800 746 4866

China:

(tel) 800 810 0189 (fax) 800 820 2816

Europe:

(tel) 31 20 547 2111

Japan:

(tel) 0120 (421) 345 (fax) 0120 421 678

Korea:

(tel) 080 769 0800 (fax) (080) 769 0900

Latin America:

(tel) 305 269 7500

Taiwan:

(tel) 0800 047 866 (fax) 0800 286 331

Other Asia Pacific Countries:

(tel) (65) 6375 8100 (fax) (65) 6755 0042

Or visit Agilent World Wide Web at:

www.agilent.com/find/assist

Product specifications and descriptions in this document are subject to change without notice. Always refer to the Agilent web site for the latest revision.

© Agilent Technologies, Inc. 2010 - 2011

Third Edition, October 26, 2011

N432A-90002



Agilent Technologies

www.valuetronics.com