

**Agilent
N1911A/1912A
P-Series Power
Meters**

Service Guide



Agilent Technologies

Notices

© Agilent Technologies, Inc. 2006 - 2011

No part of this manual may be reproduced in any form or by any means (including electronic storage and retrieval or translation into a foreign language) without prior agreement and written consent from Agilent Technologies, Inc. as governed by United States and international copyright laws.

Manual Part Number

N1912-90015

Edition

Sixth Edition, March 9, 2011

Printed in Malaysia

Agilent Technologies, Inc.
3501 Stevens Creek Blvd.
Santa Clara, CA 95052 USA

Warranty

The material contained in this document is provided “as is,” and is subject to being changed, without notice, in future editions. Further, to the maximum extent permitted by applicable law, Agilent disclaims all warranties, either express or implied, with regard to this manual and any information contained herein, including but not limited to the implied warranties of merchantability and fitness for a particular purpose. Agilent shall not be liable for errors or for incidental or consequential damages in connection with the furnishing, use, or performance of this document or of any information contained herein. Should Agilent and the user have a separate written agreement with warranty terms covering the material in this document that conflict with these terms, the warranty terms in the separate agreement shall control.

Technology Licenses

The hardware and/or software described in this document are furnished under a license and may be used or copied only in accordance with the terms of such license.

Restricted Rights Legend

U.S. Government Restricted Rights. Software and technical data rights granted to the federal government include only those rights customarily provided to end user customers. Agilent provides this customary commercial license in Software and technical data pursuant to FAR 12.211 (Technical Data) and 12.212 (Computer Software) and, for the Department of Defense, DFARS 252.227-7015 (Technical Data - Commercial Items) and DFARS 227.7202-3 (Rights in Commercial Computer Software or Computer Software Documentation).

Safety Notices

CAUTION

A **CAUTION** notice denotes a hazard. It calls attention to an operating procedure, practice, or the like that, if not correctly performed or adhered to, could result in damage to the product or loss of important data. Do not proceed beyond a **CAUTION** notice until the indicated conditions are fully understood and met.

WARNING

A **WARNING** notice denotes a hazard. It calls attention to an operating procedure, practice, or the like that, if not correctly performed or adhered to, could result in personal injury or death. Do not proceed beyond a **WARNING** notice until the indicated conditions are fully understood and met.

Certification

Agilent Technologies certifies that this product met its published specifications at the time of shipment from the factory. Agilent Technologies further certifies that its calibration measurements are traceable to the United States National Institute of Standard and Technology, to the extent allowed by the Institute's calibration facility, and to the calibration facilities of other International Standard Organization members

Limitation of Warranty

The foregoing warranty shall not apply to defects resulting from improper or inadequate maintenance by Buyer, Buyer-supplied software or interfacing, unauthorized modification or misuse, operation outside of the environmental specifications for the product, or improper site preparation or maintenance. NO OTHER WARRANTY IS EXPRESSED OR IMPLIED. AGILENT TECHNOLOGIES SPECIFICALLY DISCLAIMS THE IMPLIED WARRANTIES OF MERCHANTABILITY AND FITNESS FOR A PARTICULAR PURPOSE.

Exclusive Remedies

THE REMEDIES PROVIDED HEREIN ARE BUYER'S SOLE AND EXCLUSIVE REMEDIES. HP SHALL NOT BE LIABLE FOR ANY DIRECT, INDIRECT, SPECIAL, INCIDENTAL, OR CONSEQUENTIAL DAMAGES, WHETHER BASED ON CONTRACT, TORT, OR ANY OTHER LEGAL THEORY.

Equipment Operation

Warnings and Cautions

This guide uses warnings and cautions to denote hazards.

WARNING

A WARNING notice denotes a hazard. It calls attention to an operating procedure, practice, or the like that, if not correctly performed or adhered to, could result in personal injury or loss of life. Do not proceed beyond a WARNING notice until the indicated conditions are fully understood and met.

CAUTION

A CAUTION notice denotes a hazard. It calls attention to an operating procedure, practice, or the like that, if not correctly performed or adhered to, could result in damage to the product or loss of important data. Do not proceed beyond a CAUTION notice until the indicated conditions are fully understood and met.

Personal Safety Considerations

This is a Safety Class I product (provided with a protective earthing ground incorporated in the power cord). The mains plug shall only be inserted in a socket outlet provided with a protective earth contact. Any interruption of the protective conductor, inside or outside the instrument, is likely to make the instrument dangerous. Intentional interruption is prohibited. If this instrument is not used as specified, the protection provided by the equipment could be impaired. This instrument must be used in a normal condition (in which all means of protection are intact) only.

No operator serviceable parts inside. Refer servicing to qualified personnel. To prevent electrical shock, do not remove covers. For continued protection against fire hazard, replace the line fuse(s) only with fuses of the same type and rating (for example, normal blow, time delay, etc.). The use of other fuses or material is prohibited.

General Safety Considerations

The following general safety precautions must be observed during all phases of operation of this instrument. Failure to comply with these precautions or with specific warnings elsewhere in this manual violates safety standards of design, manufacture, and intended use of the instrument. Agilent Technologies, Inc. assumes no liability for the customer's failure to comply with these requirements.

WARNING

- **Before this instrument is switched on, make sure it has been properly grounded through the protective conductor of the ac power cable to a socket outlet provided with protective earth contact. Any interruption of the protective (grounding) conductor, inside or outside the instrument, or disconnection of the protective earth terminal can result in personal injury.**
-

CAUTION

- Any adjustments or service procedures that require operation of the instrument with protective covers removed should be performed only by trained service personnel.
-

Recommended Calibration Interval

Agilent Technologies recommends a two- years calibration cycle for the N1911A and N1912A P-Series power meter.

Safety Symbols

The following symbol on the instrument and in the documentation indicates precautions that must be taken to maintain safe operation of the instrument.



Caution, risk of danger.

The Instruction Documentation Symbol. The product is marked with this symbol when it is necessary for the user to refer to the instructions in the supplied documentation.



Alternating current (AC).



This symbol indicates the operating switch for 'Stand-by' mode. Note, the instrument is NOT isolated from the mains when the switch is pressed.

To isolate the instrument, the mains coupler (mains input cord) should be removed from the power supply.



Direct current (DC).



Both direct and alternating current.



Three-phase alternating current.

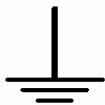

Earth (ground) TERMINAL.



PROTECTIVE CONDUCTOR TERMINAL.

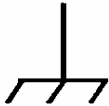

Frame or chassis TERMINAL.



Equipotentiality.



On (Supply).

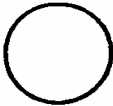

Off (Supply).

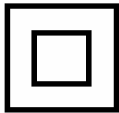

Equipment protected throughout by DOUBLE INSULATION or REINFORCED INSULATION.



Caution, risk of electric shock.



Caution, hot surface.



In position of bi-stable push control.



Out position of bi-stable push control.

Markings



The CE mark shows that the product complies with all the relevant European legal Directives (if accompanied by a year, it signifies when the design was proven).



This is the symbol of an Industrial Scientific and Medical Group 1 Class A product.



The CSA mark is a registered trademark of the Canadian Standards Association.



External Protective Earth Terminal.

While this is a Class I product, provided with a protective earthing conductor in a power cord, an external protective earthing terminal has also been provided. This terminal is for use where the earthing cannot be assured. At least an 18AWG earthing conductor should be used in such an instance, to ground the instrument to an assured earth

IEC 1010-1 Compliance

This instrument has been designed and tested in accordance with IEC Publication 1010-1 +A1:1992 Safety Requirements for Electrical Equipment for Measurement, Control and Laboratory Use and has been supplied in a safe condition. The instruction documentation contains information and warnings which must be followed by the user to ensure safe operation and to maintain the instrument in a safe condition.

Statement of Compliance

This product has been designed and tested for compliance with IEC 60529 (1989) Degrees of Protection Provided by Enclosures (IP Code). Level IPx4 is attained if, and only if, the carry case (Agilent part number 34141A) is fitted.

In This Guide ...

- 1 Specifications** Chapter 1 lists the power meter's specifications and describes how to interpret these specifications.
- 2 Performance Tests** Chapter 2 contains procedures which allow you to test the power meter's electrical performance to its specifications.
- 3 Adjustments** Chapter 3 contains checks and adjustments that ensure proper performance of the power meter.
- 4 Theory of Operation** Chapter 4 describes how each of the power meter's individual assemblies operate.
- 5 Troubleshooting Guide** Chapter 5 contains troubleshooting flow charts designed to isolate faults in the Rmt I/O, GP-IB and RS232/422 interface ports.
- 6 Repair Guide** Chapter 6 details the power meter's replaceable parts. It also explains how to assemble and disassemble the power meter.
- 7 Contacting Agilent Technologies** Chapter 7 details what to do if you have a problem with your power meter.

Contents

Notices	ii
Certification	iii
Limitation of Warranty	iii
Exclusive Remedies	iii
Equipment Operation	iv
General Safety Considerations	v
Safety Symbols	vi
Markings	ix
In This Guide ...	x

1 Specifications

Introduction	2
Specification Definitions	3
General Features	5
P-Series Power Meter and Sensor	6
P-Series Power Meter Specifications	8
P-Series Wideband Power Sensor Specifications	10
Sensor Calibration Uncertainty ⁹	11
1 mW Power Reference	12
System Specifications and Characteristics	15
Characteristics Peak Flatness	16

2 Performance Tests

Introduction	20
Complete Equipment List	21
1 mW Power Reference Level Test	23
Output Standing Wave Ratio (SWR) Test	25
Time Base Frequency Accuracy	28
Zero Set (Average Path)	30
Zero Set (Peak Path)	31
Linearity (Average Path)	32
Linearity (Peak Path)	33

Rise/Fall Time (Peak Path) 34

3 Adjustments

Introduction 38

Power Reference Level Adjustment 39

4 Theory of Operation

PPMC Assembly 42

Main Board Assembly 43

DAP Assembly 44

Calibrator Assembly 45

Front Panel Assembly 46

PSU Assembly 47

5 Troubleshooting Guide

Introduction 50

Power-Up Problems 51

Instrument Self-Test 52

Extended Self-Test 54

Performance Test 55

Power Reference Level Adjustment Problems 56

Communication Interface Failures 57

Additional Diagnostic Tests 58

6 Repair Guide

Introduction 60

Replaceable Parts 61

Tools Required 81

Required Torque Values for Fasteners 82

Disassembly Instructions 83

Reassembly Instructions 91

Disassembly vs Part Replacement 94

Front Panel Disassembly Instructions 97

Front Panel Reassembly Instructions 102

Additional Repair Notes	107
Replacing the PPMC Assembly	109
Replacing the Calibrator Semi-Rigid/Split Ferrite	110

7 Contacting Agilent Technologies

Introduction	112
Before Calling Agilent Technologies	113
Check the Basics	114
Instrument Serial Numbers	115
Agilent Sales and Service Offices	116
Returning Your Power Meter for Service	117
Useful Web Pages	118

List of Figures

- Figure 2-1 1 mW Power Reference Level Test Setup Connection Diagram 23
- Figure 2-2 System Calibration Connection Diagram 26
- Figure 2-3 Output SWR Test Setup - Open Connection Diagram 26
- Figure 2-4 Output SWR Test Setup - Load Connection Diagram 26
- Figure 2-5 Time Base Test Setup Connection Diagram 28
- Figure 2-6 Rise/Fall Time Test Setup Connection Diagram 34



1 Specifications

Introduction	2
Specification Definitions	3
General Features	5
P-Series Power Meter and Sensor	6
P-Series Power Meter Specifications	8
P-Series Wideband Power Sensor Specifications	10
Sensor Calibration Uncertainty ⁹	11
1 mW Power Reference	12
System Specifications and Characteristics	15
Characteristics Peak Flatness	16

This chapter lists the power meter's specifications and describes how to interpret these specifications.



Introduction

This chapter details the power meter's specifications and supplemental characteristics

Specifications describe the warranted performance and apply after a 30 minute warm-up. These specifications are valid over the power meter's operating and environmental range unless otherwise stated and after performing a zero and calibration.

Supplemental characteristics, which are shown in italics, are intended to provide information useful in applying the power meter by giving typical, but non warranted performance parameters. These characteristics are shown in italics or denoted as "attributes", "nominal" or "approximate".

For information on measurement uncertainty calculations, refer to Agilent Application Note 64-1A, "Fundamentals of RF and Microwave Power Measurements", Literature 5965-6630E.

Specification Definitions

There are two types of product specifications:

Warranted specifications are specifications which are covered by the product warranty and apply over 0 to 55½ °C unless otherwise noted. Warranted specifications include measurement uncertainty calculated with a 95 % confidence.

Characteristic specifications are specifications that are not warranted. They describe product performance that is useful in the application of the product. These characteristic specifications are shown in *italics*.

Characteristic information is representative of the product. In many cases, it may also be supplemental to a warranted specification. Characteristic specifications are not verified on all units. There are several types of characteristic specifications. These types can be placed in two groups:

One group of characteristic types describes ‘attributes’ common to all products of a given model or option. Examples of characteristics that describe ‘attributes’ are product weight, and 50 Ω input Type-N connector. In these examples product weight is an ‘approximate’ value and a 50 Ω input is ‘nominal’. These two terms are most widely used when describing a product’s ‘attributes’.

The second group describes ‘statistically’ the aggregate performance of the population of products.

These characteristics describe the expected behavior of the population of products. They do not guarantee the performance of any individual product. No measurement uncertainty value is accounted for in the specification. These specifications are referred to as ‘typical’.

Conditions

The power meter and sensor will meet its specifications when:

- stored for a minimum of two hours at a stable temperature within the operating temperature range, and turned on for at least 30 minutes
- the power meter and sensor are within their recommended calibration period, and
- used in accordance to the information provided in the user's guide.

General Features

Number of channels	N1911A P-Series power meter, single channel N1912A P-Series power meter, dual channel
Frequency range	N1912A P-Series wideband power sensor, 50 MHz to 18 GHz N1922A P-Series wideband power sensor, 50 MHz to 40 GHz
Measurements	Average, peak and peak-to-average ratio power measurements are provided with free-run or time gate definition. Time parameter measurements of pulse rise time, fall time, pulse width, time to positive occurrence and time to negative occurrence are also provided.
Sensor compatibility	P-Series power meters are compatible with all Agilent P-Series wideband power sensors, E-Series sensors, 8480 Series power sensors and N8480 Series sensors ¹ .

¹ Information contained in this document refers to operation with P-Series sensors. For specifications when used with 8480 and E-Series sensors (except E9320 range), refer to Lit Number 5965-6382E. For specifications when used with E932XA sensors, refer to Literature Number 5980-1469E. For specifications when used with N8480 Series sensors, refer to Lit Number 5989-9333EN.

P-Series Power Meter and Sensor

Key System Specifications and Characteristics

Maximum sampling rate	100 Msamples/sec, continuous sampling
Video bandwidth	≥ 30 MHz
Single shot bandwidth	≥ 30 MHz
Rise time and fall time	≤ 13 ns (for frequencies ≥ 500 MHz) ³ , see Figure 1-1
Minimum pulse width	50 ns ⁴
Overshoot	≤ 5 % ³
Average power measurement accuracy	N1921A: ≤ ± 0.2 dB or ± 4.5 % ⁵ N1922A: ≤ ± 0.3 dB or ± 6.7 %
Dynamic range	–35 dBm to +20 dBm (> 500 MHz) –30 dBm to +20 dBm (50 MHz to 500 MHz)
Maximum capture length	1 second
Maximum pulse repetition rate	10 MHz (based on 10 samples per period)

³ Specification applies only when the Off video bandwidth is selected.

⁴ The Minimum Pulse Width is the recommended minimum pulse width viewable on the power meter, where power measurements are meaningful and accurate, but not warranted.

⁵ Specification is valid over –15 to +12 dBm, and a frequency range 0.5 to 10 GHz, DUT Max. SWR < 1.27 for the N1921A, and a frequency range 0.5 to 40 GHz, DUT Max. SWR < 1.2 for the N1922A. Averaging set to 32, in Free Run mode.

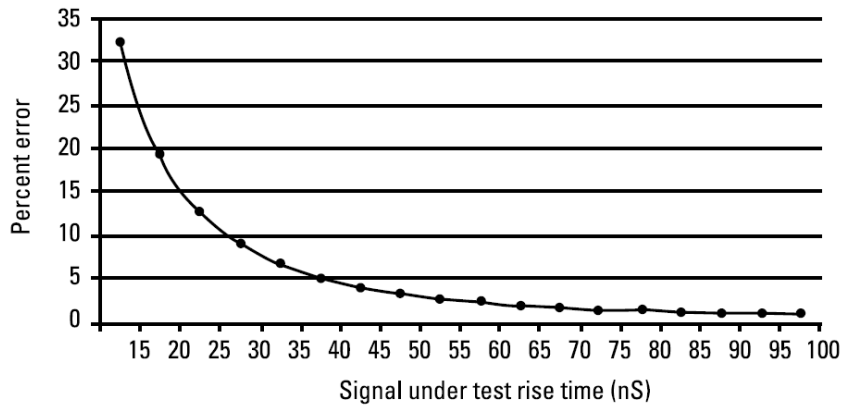

Figure 1-1 Measured rise time percentage error versus signal under test rise time

Although the rise time specification is ≤ 13 ns, this does not mean that the P-Series meters and sensors combination can accurately measure a signal with a known rise time of 13 ns. The Measured rise time is the root sum of the squares (RSS) of the signal under test rise time and the system rise time (13 ns):

Measured rise time = $\sqrt{((\text{signal under test rise time})^2 + (\text{system rise time})^2)}$,
and the % error is:

% Error = $((\text{measured rise time} - \text{signal under test rise time}) / \text{signal under test rise time}) \times 100$

P-Series Power Meter Specifications

Meter uncertainty

Instrumentation linearity	$\pm 0.8\%$
---------------------------	-------------

Timebase

Timebase range	<i>2 ns to 100 msec/div</i>
Accuracy	± 10 ppm
Jitter	≤ 1 ns

Trigger

Internal trigger

Range	-20 to $+20$ dBm
Resolution	0.1 dB
Level accuracy	± 0.5 dB
Latency ⁶	160 ns ± 10 ns
Jitter	≤ 5 ns rms

External TTL trigger input

High	> 2.4 V
Low	< 0.7 V
Latency ⁷	90 ns ± 10 ns
Minimum trigger pulse width	15 ns
Minimum trigger repetition period	50 ns
Impedance	$50\ \Omega$
Jitter	≤ 5 ns rms

External TTL trigger output

	Low to high transition on trigger event.
High	> 2.4 V
Low	< 0.7 V
Latency ⁸	30 ns ± 10 ns
Impedance	$50\ \Omega$
Jitter	≤ 5 ns rms

Trigger delay

Delay range	± 1.0 s, maximum
Delay resolution	1% of delay setting, 10 ns maximum

Trigger hold-off

Range	1 μ s to 400 ns
Resolution	1% of selected value (to a minimum of 10 ns)

Trigger level threshold hysteresis

Range	± 3 dB
Resolution	0.05 dB

⁶ Internal trigger latency is defined as the delay between the applied RF crossing the trigger level and the meter switching into the triggered state.

⁷ External trigger latency is defined as the delay between the applied trigger crossing the trigger level and the meter switching into the triggered state.

⁸ External trigger output latency is defined as the delay between the meter entering the triggered state and the output signal switching.

P-Series Wideband Power Sensor Specifications

The P-Series wideband power sensors are designed for use with the P-Series power sensor only.

Sensor model	Frequency range	Dynamic range	Damage level	Connector type
N1921A	50 MHz to 18 GHz	-35 dBm to +20 dBm (500 MHz) -30 dBm to +20 dBm (50 MHz to 500 MHz)	+23 dBm (average power); +30 dBm (<1 μs duration)(peak power)	Type N (m)
N1922A	50 MHz to 40 GHz	35 dBm to +20 dBm (500 MHz) -30 dBm to +20 dBm (50 MHz to 500 MHz)		2.4mm (m)

Maximum SWR

Frequency band	N1921A/N1922A
50 MHz to 10 GHz	1.2
10 GHz to 18 GHz	1.26
18 GHz to 26.5 GHz	1.3
26.5 GHz to 40 GHz	1.5

Sensor Calibration Uncertainty⁹

Definition: Uncertainty resulting from non-linearity in the sensor detection and correction process. This can be considered as a combination of traditional linearity, cal factor and temperature specifications and the uncertainty associated with the internal calibration process.

⁹ Beyond 70 % Humidity, and additional 0.6 % should be added to these values.

Frequency band	N1921A	N1922A
50 MHz to 500 MHz	4.5 %	4.3 %
500 MHz to 1 GHz	4.0 %	4.2 %
1 GHz to 10 GHz	4.0 %	4.4 %
10 GHz to 18 GHz	5.0 %	4.7 %
18 GHz to 26.5 GHz		5.9 %
26.5 GHz to 40 GHz		6.0 %

Physical characteristics

Dimensions	N1921A N1922A	<i>135 mm x 40 mm x 27mm</i> <i>127 mm x 40 mm x 27 mm</i>
Weights with cable	Option 105 Option 106 Option 107	<i>0.4 kg</i> <i>0.6 kg</i> <i>1.4 kg</i>
Fixed sensor cable lengths	Standard Option 106 Option 107	<i>1.5 m (5-feet)</i> <i>3.0 m (10-feet)</i> <i>10 m (31-feet)</i>

1 mW Power Reference

NOTE

The 1mW power reference is provided for calibration of E-Series, 8480 Series and N8480 Series sensors. The P-Series sensors are automatically calibrated do not need this reference calibration.

Power output	1.00 mW (0.0 dBm). Factory set $\pm 0.4\%$ traceable to the National Physical Laborator (NPL) UK
Accuracy (over 2 years)	$\pm 1.2\%$ (0 to 55 °C) $\pm 0.4\%$ (25 to 10 °C)
Frequency	50 MHz nominal
SWR	1.08 (0 to 55 °C) <i>1.05 typical</i>
Connector type	Type N (f), 50 Ω

Rear panel inputs/outputs

Recorder output	Analog 0-1 Volt, 1 k Ω output impedance, BNC connector. For dual channel instruments there will be two recorder outputs.	
GPIO, 10/100 BaseT LAN and USB 2.0	Interfaces allow communication with an external controller.	
Ground	Binding post, accepts 4 mm plug or bare-wire connection.	
Trigger input	Input has TTL compatible logic levels and uses a BNC connector.	
Trigger output	Output provides TTL compatible logic levels and uses.	
Line power	A BNC connector	
• Input voltage range	90 to 264 Vac, automatic selection	
• Input frequency range	47 to 63 Hz and 440 Hz	
• Power requirement	N1911A	not exceeding 50 VA (30 Watts)
	N1912A	not exceeding 75 VA (50 Watts)

Remote Programming

Interface	GPIB interface operates to IEEE 488.2 and IEC65 10/100 BaseT LAN interface USB 2.0 interface
Command language	SCPI standard interface commands
GPIB compatibility	SH1, AH1, T6, TE0, L4, LE0, SR1, RL1, PP1, DC1, DT1, C0

Measurement Speed

Measurement speed via remote interface ≥ 1500 readings per second
--

Regulatory Information

Electromagnetic compatibility	Complies with the requirements of the EMC Directive 89/336/EEC
Product safety	Conforms to the following product specifications: <ul style="list-style-type: none"> • EN61010-1: 2001/IEC 1010-1:2001/CSA C22.2 No.1010-1:1993 • IEC 60825-1:1993/A2:2001/IEC 60825-1:1993 +A1:1997+A2:2001 • Low Voltage Directive 72/23/EEC

Physical Characteristics

Dimensions	The following dimensions exclude front and rear panel protrusions: 88.5 mm H x 212.6 mm W x 348.3 mm D (3.5 in x 8.5 in x 13.7 in)	
Net weight	N1911A	≤ 3.5 kg (7.7 lb) approximate
	N1912A	≤ 3.7 kg (8.1 lb) approximate
Shipping weigh	N1911A	≤ 7.9 kg (17.4 lb) approximate
	N1912A	≤ 8.0 kg (17.6 lb) approximate

Environmental Conditions

<i>General</i>	Complies with the requirement of the EMC Directive 89/336/EEC.	
<i>Operating</i>		
Temperature	0 ° C to 55 ° C	
Maximum humidity	95 % at 40 ° C (non-condensing)	
Minimum humidity	15 % at 40 ° C (non-condensing)	
Maximum altitude	3,000 meters (9,840 feet)	
<i>Storage</i>		
Non-operating storage temperature	−30 ° C to +70 ° C	
Non-operating maximum humidity	90 % at 65 ° C (non-condensing)	
Non-operating altitude	15,420 meters (50,000 feet)	

System Specifications and Characteristics

The video bandwidth in the meter can be set to High, Medium, Low and Off. The video bandwidths stated in the table below are not the 3 dB bandwidths, as the video bandwidths are corrected for optimal flatness (except the Off filter). Refer to [Figure 1-2](#) for information on the flatness response. The Off video bandwidth setting provides the warranted rise time and fall time specification and is the recommended setting for minimizing overshoot on pulse signals.

Dynamic response - rise time, fall time, and overshoot versus video bandwidth settings

Parameter	Video bandwidth setting				
	Low: 5MHz	Medium: 15 MHz	High: 30 MHz	Off	
				< 500 MHz	> 500 MHz
Rise time/fall time ¹⁰	< 56 ns	< 25 ns	< 13 ns	< 36 ns	< 13 ns
Overshoot ¹¹				< 5 %	< 5 %

For option 107 (10 m cable), add 5 ns to the rise time and fall time specifications.

¹⁰ Specified as 10 % to 90 % for rise time and 90 % to 10 % for fall time on a 0 dBm pulse.

¹¹ Specified as the overshoot relative to the settled pulse top power.

Characteristics Peak Flatness

The peak flatness is the flatness of a peak-to-average ratio measurement for various tone-separations for an equal magnitude two-tone RF input. Figure 1-2 refers to the relative error in peak-to-average ratio measurements as the tone separation is varied. The measurements were performed at -10 dBm with power sensors with 1.5 m cable lengths.

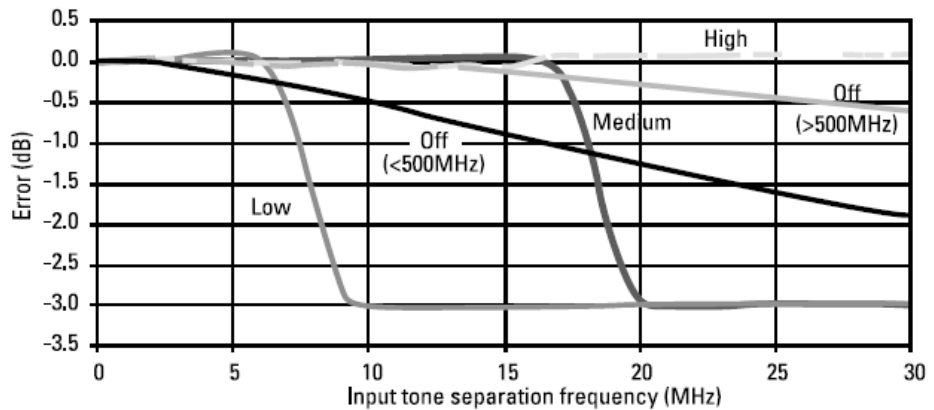

Figure 1-2 N192XA Error in peak-to-average measurements for a two-tone input (High, Medium, Low and Off filters)

Noise and drift

Sensor Model	Zeroing	Zero set		Zero drift ¹²	Noise per sample	Measurement noise (Free run) ¹³
		< 500 MHz	> 500 MHz			
N1921A/ N1922A	No RF on input	200 nW		100 nW	2 μ W	50 nW
	RF present	550 nW	200 nW			

¹² Within 1 hour after a zero, at a constant temperature, after 24 hour warm up of the power meter. This component can be disregarded with Auto zero mode set to ON.

¹³ Measured over a one minute interval, at a constant temperature, two standard deviations, with averaging set to 1.

Measurement average setting	1	2	4	8	16	32	64	128	256	512	1024
-----------------------------	---	---	---	---	----	----	----	-----	-----	-----	------

Free run noise multiplier	1	0.9	0.8	0.7	0.6	0.5	0.45	0.4	0.3	0.25	0.2
---------------------------	---	-----	-----	-----	-----	-----	------	-----	-----	------	-----

Video BW setting		Low 5 MHz	Medium 15 MHz	High 30 MHz	Off
Noise per sample multiplier	< 500 MHz	0.5	1	2	1
	> 500 MHz	0.45	0.75	1.1	1

Effect of video bandwidth setting

The noise per sample is reduced by applying the meter video bandwidth filter setting (High, Medium or Low). If averaging is implemented, this will dominate any effect of changing the video bandwidth.

Effect of time-gating on measurement

The measurement noise on a time-gated measurement will depend on the time gate length. 100 averages are carried out every 1 μ s of gate length. The Noise per Sample contribution in this mode can approximately be reduced by $\sqrt{(\text{gate length}/ 10 \text{ ns})}$ to a limit of 50 nW.

1 Specifications



2 Performance Tests

Introduction	20
Complete Equipment List	21
1 mW Power Reference Level Test	23
Output Standing Wave Ratio (SWR) Test	25
Time Base Frequency Accuracy	28
Zero Set (Average Path)	30
Zero Set (Peak Path)	31
Linearity (Average Path)	32
Linearity (Peak Path)	33
Rise/Fall Time (Peak Path)	34

This chapter contains procedures which allow you to test the power meter's electrical performance to its specifications.



Introduction

The performance tests described in this chapter test the power meter's electrical performance against the specifications detailed in [Chapter 1](#). They are used for incoming inspection, the calibration cycle (also called periodic maintenance), or after repairs have been made.

NOTE

- This document does not provide a complete breakdown for these tests; it only gives a brief overview of each, in line with Agilent's recommendation that the Agilent N7832A calibration software should be used at all times.
- Performance testing is limited to the measurement and verification of warranted specifications.
- Some tests cannot be performed manually, and so the N7832A calibration software is essential.
- Measurement uncertainty will not be addressed in this document (this is handled by the N7832A software).

The following performance tests are described in this chapter:

- [1 mW Power Reference Level Test](#)
- [Output Standing Wave Ratio \(SWR\) Test](#) (Power Reference Output)
- [Time Base Frequency Accuracy](#)
- [Zero Set \(Average Path\)](#)
- [Zero Set \(Peak Path\)](#)
- [Linearity \(Average Path\)](#)
- [Linearity \(Peak Path\)](#)
- [Rise/Fall Time \(Peak Path\)](#)

Complete Equipment List

Instrument	Critical Specifications	Recommended Agilent Model Number	Alternative Agilent Model Number
Analyzers			
Network analyzer		N3383A	N3381A N3382A 8753ES/ET
Counters			
Universal counter	Frequency: 10 MHz Gate Time: 10 seconds	53132A	53131A
Meters			
Power meter	Dual channel Absolute Accuracy: $\pm 0.5\%$ Power Reference Accuracy: $\pm 0.9\%$ - (a best capability measurement is required for the Power Reference Output - the power level must be accurately measured, and the uncertainty of this measurement must also be known)	E4419B	E4419A
Power sensor 2 required	Frequency: 50 MHz Amplitude Range: -70 dBm to -20 dBm SWR: ≤ 1.15 at 50 MHz	8481D	
Power sensor	Frequency: 50 MHz Amplitude Range: -30 dBm to $+20$ dBm SWR: ≤ 1.1 at 50 MHz	8482A	
Attenuators			
20 dB Fixed attenuator	Type-N(m,f)	8491A (Option 020)	
30 dB Fixed attenuator	Type-N(m,f)	11708A	
Miscellaneous Devices			
10 MHz Frequency standard			

2 Performance Tests

Pulse/Data generator 81131A Output modules required		81130A	
Power splitter required	Frequency: DC to 6 GHz Insertion Loss: 6 to 7 dB, ≤ 3 GHz SWR: < 1.1 10 MHz to 2 GHz < 1.3 2 GHz to 3 GHz	11667A (Option 001)	
BNC cable	Frequency: DC to 10 GHz 50 Ω Coax BNC (m), both ends 120 cm (48 in)	10503A	
Calibration test cable required for N1912A		N1912-61017	
Sensor cable required		11730A	
N-Type Calibration kit		85032B	
Assorted accessories (cables and adapters) required			

1 mW Power Reference Level Test

Description

The 1 mW power reference is used for the calibration of 8480 Series, N8480 Series and E-Series power sensors, and is traceable to national standards. This test uses an 8482A power sensor to transfer the power measured on an accurately calibrated E4419B or E4417A power meter to the DUT reference.

Equipment

- Required test equipment:
 - 1 unit of E4419B or E4417A dual channel power meter,
 - 1 unit of 8482A power sensor.
 - 11730A power sensor cable
- Either of these E4419B or E4417A power meters can be used. This specific power sensor model must be used.

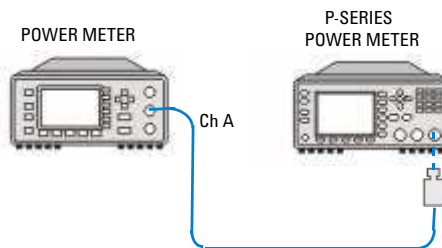

Figure 2-1 1 mW Power Reference Level Test Setup Connection Diagram

NOTE

For rear panel options, the connections will differ from the illustration shown here. Refer to the connector identification markings on the rear panel for further details

Test Method

- 1 Enter the recorded measurement uncertainty of the E4419B or E4417A 1 mW power reference
- 2 Using the E4419B or E4417A power meter and the 8482A sensor, measure the 1mW power reference of the E4419B or E4417A
- 3 Using the E4419B or E4417A power meter and the 8482A sensor, measure the 1 mW power reference of the DUT
- 4 Using all of these values, the N7832A software will calculate the power reference level of the DUT

NOTE

- The 1 mW reference of the E4419B or E4417A power meter must be precisely calibrated at a standards accredited lab, and the uncertainty of this measurement known.
 - Anyone who has a basic understanding of metrology should be able to perform this test manually; it is simply the transfer of known power level with a known calibration uncertainty to the DUT.
 - An adjustment is available for this test if it fails (see [Chapter 3](#), “Adjustments”).
-

Output Standing Wave Ratio (SWR) Test

Description

Connector mismatch is the largest single contributor to measurement uncertainty, so this specification must be warranted to provide assurance of instrument accuracy. The 1 mW power reference level test must be carried out prior to this test, as the VSWR specification is only valid at 1 mW. This test measures VSWR by equating relative powers (measured by the test system power meter and its sensors) when the power reference is exercised under different load conditions.

Equipment

- Required test equipment:
 - 1 unit of 8753ES/ ET network analyzer
 - 1 unit of 85032B Type N calibration kit
 - 1 unit of E4419B or E4417A dual channel power meter
 - 2 unit of 8481D power sensor
 - 2 unit of 11667A #001 power splitter
 - 1 unit of 20dB pad, male to female (e. g. 8491A)
 - 1 unit of 30dB pad (e. g. 11708A reference attenuator)
 - 2 unit of 11730A power sensor cable
- An alternative network analyzer can be used, as long as it can measure S11 in the 45 MHz -55 MHz range
- Either of these E4419B or E4417A power meters can be used
- These specific models of power sensors and power splitters must be used
- Any type of pad can be used (as long as there are no additional mating connections, or differing pad values)
- 1 unit of 11667A, 1 unit of 8481D and the 30 dB pad combine to create the 'Calibration System'
- 1 unit of 11667A, 1 unit of 8481D and the 20 dB pad combine to create the 'Measurement System'

2 Performance Tests

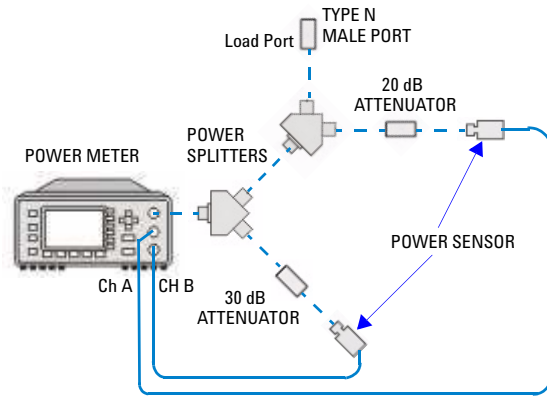

Figure 2-2 System Calibration Connection Diagram

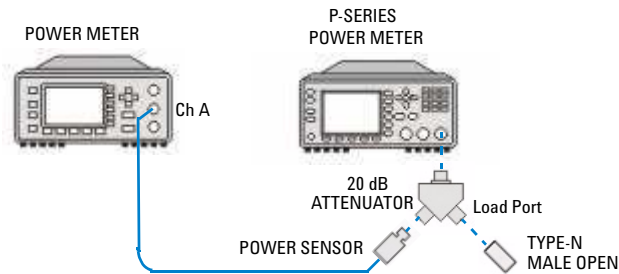

Figure 2-3 Output SWR Test Setup - Open Connection Diagram

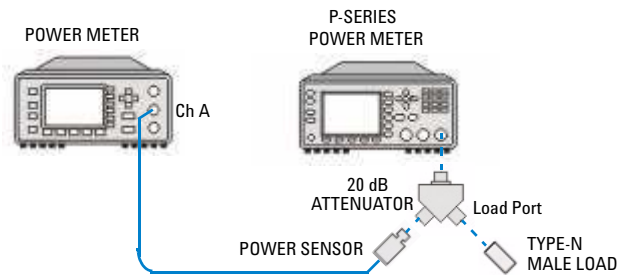

Figure 2-4 Output SWR Test Setup - Load Connection Diagram

NOTE

For rear panel options, the connections will differ from the illustration shown here. Refer to the connector identification markings on the rear panel for further details

Test Method

- 1 Obtain the S11 parameter of the calibration system.
- 2 Connect the measurement system to the calibration system and obtain its S21 (load) & S21 (open) parameters.
- 3 Using only the measurement system, terminated with the OPEN connector from the 85032B calibration kit, measure the 1 mW power reference level of the DUT.
- 4 Remove the OPEN connector from the measurement system, terminate it with the 50 R load from the 85032B calibration kit, and repeat the 1 mW power reference level measurement.
- 5 Using all of these values, the N7832A software will calculate the VSWR of the power reference output.

NOTE

- This test cannot be performed manually, due to the complexity of the equipment calibration procedure, and the complexity of the measurement algorithm.
 - No adjustment is available for this test if it fails (see [Chapter 5](#), “Troubleshooting Guide”).
-

Time Base Frequency Accuracy

Description

The accuracy of the 100 MHz sample clock determines the accuracy of all measurements that are based on samples taken over time. This test measures the time base by dividing the sample clock by 10 (within the meter) and feeding it out of the trigger output connector, where it can be directly measured by a frequency counter.

Equipment

- Required test equipment:
 - 1 unit of 53132A frequency counter
 - 10 MHz frequency standard
 - 1 unit of 10503A BNC cable
- An alternative frequency counter can be used, as long as it has the appropriate bandwidth (> 10 MHz)

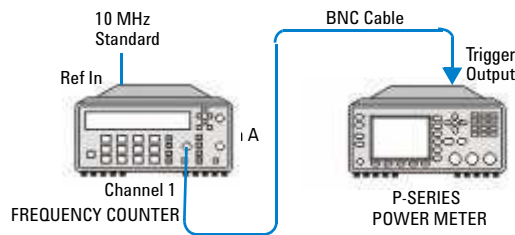

Figure 2-5 Time Base Test Setup Connection Diagram

NOTE

For rear panel options, the connections will differ from the illustration shown here. Refer to the connector identification markings on the rear panel for further details

Test Method

- 1 Enable the path that routes the time base signal to the trigger output connector.
- 2 Using the 53132A, measure the frequency of the signal at the trigger output connector.

NOTE

- This test can be configured manually via the command `SERV:BIST:TBAS:STAT ON`, which enables the 10 MHz feed to the trigger output connector (refer to the programming guide for further details on the use of this command).
 - This test can also be configured manually via the front panel; access the Service menu, select Self Test, and select Time Base to enable the 10 MHz feed to the trigger output connector.
 - No adjustment is available for this test if it fails (see [Chapter 5](#), “Troubleshooting Guide”).
-

Zero Set (Average Path)

Description

Zero set is defined as the amount of residual offset error that is present following a zero operation. This offset error is caused by contamination from several sources, including circuit noise. This test measures the effectiveness of zero set by performing 15 back-to-back zero operations of the average path (with no sensor attached), after which the standard deviation of the results is calculated and returned as the measured value.

Equipment

- No test equipment required

Test Method

- 1 Execute the internal zero set measurement procedure for channel A.
- 2 Read back the result of the measurement from the DUT.
- 3 If the DUT model number is N1912A, then repeat this procedure for channel B.

NOTE

- This test can be performed manually via the commands:
`SERV:BIST:PEAK[1|2]:ZSET`
`SERV:BIST:CW[1|2]:ZSET:NUM?`
(Refer to the programming guide for further details on the use of these commands)
 - No adjustment is available for this test if it fails (see [Chapter 5](#), “Troubleshooting Guide”).
-

Zero Set (Peak Path)

Description

Zero set is defined as the amount of residual offset error that is present following a zero operation. This offset error is caused by contamination from several sources, including circuit noise. This test measures the effectiveness of zero set by performing 15 back-to-back zero operations of the peak path (with no sensor attached), after which the standard deviation of the results is calculated and returned as the measured value.

Equipment

- No test equipment required

Test Method

- 1 Execute the internal zero set measurement procedure for channel A.
- 2 Read back the result of the measurement from the DUT.
- 3 If the DUT model number is N1912A, then repeat this procedure for channel B.

NOTE

- This test can be performed manually via the commands:
`SERV:BIST:PEAK[1|2]:ZSET`
`SERV:BIST:PEAK[1|2]:ZSET:NUM?`
(Refer to the programming guide for further details on the use of these commands)
 - No adjustment is available for this test if it fails (see [Chapter 5](#), “Troubleshooting Guide”).
-

Linearity (Average Path)

Description

Linearity over the full input voltage range of the measurement path is warranted to provide assurance of instrument accuracy. This test measures linearity by using a calibration DAC and a calibration ADC (built into the DUT) to stimulate and compare performance of the average path against the measurement ADC, returning the worst case percentage error.

Equipment

- No test equipment required

Test Method

- 1 Execute the internal linearity measurement procedure for channel A.
- 2 Read back the result of the measurement from the DUT.
- 3 If the DUT model number is N1912A, then repeat this procedure for channel B.

NOTE

- This test can be performed manually via the commands:
`SERV:BIST:CW[1|2]:LIN 0`
`SERV:BIST:CW[1|2]:LIN:PERR?`
(Refer to the programming guide for further details on the use of these commands)
 - No adjustment is available for this test if it fails (see [Chapter 5](#), “Troubleshooting Guide”).
-

Linearity (Peak Path)

Description

Linearity over the full input voltage range of the measurement path is warranted to provide assurance of instrument accuracy. This test measures linearity by using a calibration DAC and a calibration ADC (built into the DUT) to stimulate and compare performance of the peak path against the measurement ADC, returning the worst case percentage error.

Equipment

- No test equipment required

Test Method

- 1 Execute the internal linearity measurement procedure for channel A.
- 2 Read back the result of the measurement from the DUT.
- 3 If the DUT model number is N1912A, then repeat this procedure for channel B.

NOTE

- This test can be performed manually via the commands:
`SERV:BIST:PEAK[1|2]:LIN 0`
`SERV:BIST:PEAK[1|2]:LIN:PERR?`
(Refer to the programming guide for further details on the use of these commands)
 - No adjustment is available for this test if it fails (see [Chapter 5](#), “Troubleshooting Guide”).
-

Rise/Fall Time (Peak Path)

Description

The rise and fall time performance of the instrument path has to be quantified accurately. The 81130A pulse generator is used to supply the appropriate pulse with defined rise and fall time. The instrument measures and processes the known signal which is then compared with defined acceptance limits. Overshoot, settling time and pulse recovery are also characterized.

Equipment

- Required test equipment:
 - 1 unit of 81130A pulse/data generator mainframe
 - 2 unit of 81131A output modules (installed in 81130A)
 - 2 unit of N1912-61017 calibration test cable
 - 2 unit of 10503A BNC cable
 - 2 unit of adapter, BNC to SMC

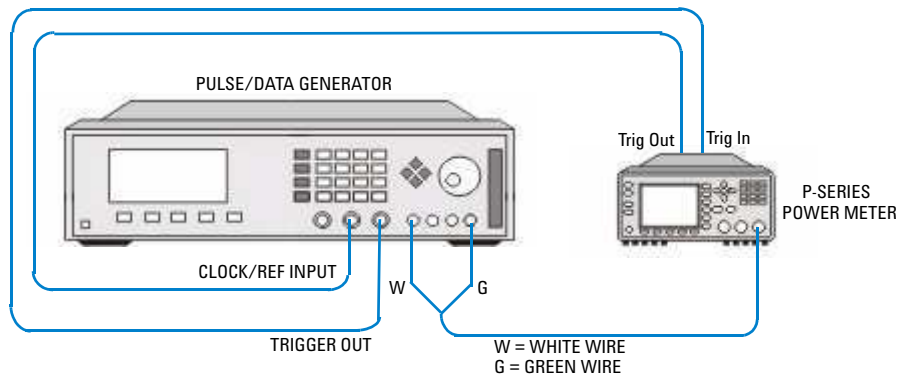

Figure 2-6 Rise/Fall Time Test Setup Connection Diagram

NOTE

For rear panel options, the connections will differ from the illustration shown here. Refer to the connector identification markings on the rear panel for further details

Test Method

- 1 Capture a train of 10 pulses with very fast rise/fall times.
- 2 Combine the sample data to create an equivalent pulse with 10 unit of the sample resolution of the DUT.
- 3 Analyze the equivalent pulse to determine the 10 % and 90 % voltage levels of the risign/falling edges
- 4 Analyze the equivalent pulse to determine when the 10 % and 90 % crossover points occur for both edges.
- 5 Using the times obtained for the 10 % & 90 % crossovers, the N7832A software will calculate the rise/fall time performance of the DUT.

NOTE

- Only 1 cable is required if the DUT is an N1911A.
 - This test cannot be performed manually, due to the complexity of the pulse analysis algorithm.
 - No adjustment is available for this test if it fails (see [Chapter 5](#), “Troubleshooting Guide”).
-

2 Performance Tests



3 Adjustments

Introduction 38

Power Reference Level Adjustment 39

This chapter contains checks and adjustments that ensure proper performance of the power meter.



Introduction

Attempts to correct the power reference level if the performance test has failed. Power reference level is controlled by the coarse and fine settings of a digital potentiometer. Adjustment of the coarse and fine settings can only be carried out via remote commands. Adjustment can be carried out without having to remove the outer covers from the DUT.

Power Reference Level Adjustment

Equipment

- As per the test equipment list for the power reference level performance test

Test Method

- 1 Set: Coarse = 834, Fine = 550
- 2 Measure power ref. level as per the performance test:
 - a If the result is > 1 mW, the increment COARSE by 1
 - b If the result is < 1 mW, the decrement COARSE by 1
- 3 Repeat step 2 until the result crosses the 1 mW boundary (in either direction)
- 4 Measure power ref. level as per the performance test:
 - a If the result is > 1 mW, then decrement FINE by 1
 - b If the result is < 1 mW, then increment FINE by 1
- 5 Repeat step 4 until the result crosses the 1 mW boundary (in either direction)
- 6 The adjustment is completed

NOTE

- This adjustment can be performed manually via the commands:
`SERV:CAL:ADJ:COUR <Value>`
`SERV:CAL:ADJ:COUR?`
`SERV:CAL:ADJ:FINE <Value>`
`SERV:CAL:ADJ:FIINE?`
 (Refer to the programming guide for further details on the use of these commands)
- COARSE and FINE values are valid in the range of 0 to 1023
- If adjustment is not possible, then a fault may be present in the DUT (see [Chapter 5](#), "Troubleshooting Guide").

3 Adjustments



4 Theory of Operation

PPMC Assembly	42
Main Board Assembly	43
DAP Assembly	44
Calibrator Assembly	45
Front Panel Assembly	46
PSU Assembly	47

This chapter describes how each of the power meter's individual assemblies operate.



PPMC Assembly

Purpose

- Provides the main processor and memory for the power meter
- Provides external interfaces for LAN and USB
- Stores the power meter firmware in flash EEPROM
- Stores the power meter serial number and option data

Inputs

- Power supplies [from PSU, via main board]
- Control and data lines [from main board, DAP(s), and front panel]
- LAN/ USB communications [from external equipment]
- GPIB communications [from external equipment, via main board]

Outputs

- Control, address, and data lines [to main board, DAP(s), and front panel]

Main Board Assembly

Purpose

- Provides the average measurement path(s)
- Provides the peak measurement path(s) to the DAP(s)
- Provides external trigger input/ output and recorder output(s)
- Provides the driver and the LVDS serialiser for the LCD display
- Provides signal routing between the PPMC, DAP(s), and front panel

Inputs

- Power supplies [from PSU]
- Sensed power level(s) [from sensor flexi(s)]
- Trigger input [from external equipment]
- Control, address, and data lines [from PPMC]

Outputs

- Processed average path measurement [to PPMC]
- Unprocessed peak path measurement samples [to DAP(s)]
- Trigger output & recorder output(s) [to external equipment]
- LVDS LCD display control lines [to front panel]
- Control and data lines [to PPMC]

DAP Assembly

Purpose

- Provides data acquisition and processing for the peak measurement path of a channel

Inputs

- Power supplies [from PSU, via main board]
- Unprocessed peak path measurement samples [from main board]
- Control, address, and data lines [from PPMC]

Outputs

- Processed peak path measurement data [to PPMC, via main board]
- Control and data lines [to PPMC, via main board]

Calibrator Assembly

Purpose

- Provides a 1 mW (0 dBm) power reference level at 50 MHz

Inputs

- Power supplies [from PSU, via main board]
- Control, address, and data lines [from PPMC]

Outputs

- 1 mW (0 dBm) power reference [to external equipment]
- Control and data lines [to PPMC, via main board]

Front Panel Assembly

Purpose

- Provides a keyboard as the manual user interface
- Provides an LCD display to assist with manual setups and measurements
- Provides mounting for the sensor and power reference connectors (option 101)

Inputs

- Power supplies [from PSU, via main board]
- Front panel control interface [from the PPMC LVDS LCD control lines, via main board]

Outputs

- Keypress data [to PPMC, via main board]
- Information on the LCD display
- Control and data lines [to PPMC, via main board]

PSU Assembly

Purpose:

- Provides various DC power supplies

Inputs:

- 100 Vac~ 240 Vac, 50 Hz~ 60 Hz, 150 VA Max [from an external source]
- Control lines [from front panel, via main board]

Outputs:

- +12 Vdc [to main board]
- +5 Vdc]to main board]
- -5 Vdc [to main board]
- -12 Vdc [to main board]

4 Theory of Operation



5 Troubleshooting Guide

Introduction	50
Power-Up Problems	51
Instrument Self-Test	52
Extended Self-Test	54
Performance Test	55
Power Reference Level Adjustment Problems	56
Communication Interface Failures	57
Additional Diagnostic Tests	58

This chapter contains troubleshooting flow charts designed to isolate faults in the Rmt I/O, GP-IB and RS232/422 interface ports.



Introduction

This chapter enables qualified service personnel to diagnose suspected faults with the power meter Rmt I/O (Remote Input/Output) signal lines and RS232/422 serial port.

If there is a problem when attempting to use the RS232/422 serial interface or the remote I/O functions, consult the user's guide and confirm that all the user setups are correct before proceeding with the following fault finding flowcharts.

Power-Up Problems

Basic External Checks

- Check the mains power source is live
- Check the mains fuse is operational
- Check the mains cable for any obvious damage
- Check the line module fuse in the instrument is operational

Basic Internal Checks

- Check/reseat the cable between the line module and the PSU
- Check/reseat the cable between the PSU and the main board
- Green LED DS1: If this is off, then the PSU may be faulty
- Green LED DS4: This should come on when the power button is pressed
- Green LEDs DS2/DS3: These will flash on and off during normal operation

Possible Faults

- PSU
- Main board
- Front panel (defective keymat, key flex circuit, or display)
- Loose front panel cable (connection to main board)

Instrument Self-Test

Instrument	Purpose	Debug Tips	Possible Faults
Test point voltages	Checks that all of the supply voltages are present	Replace the PSU to see if this clears the faults	PSU (low probability) Main board (high probability)
Calibrator	Verifies that the calibrator is working (Note: This test does not check that the calibrator meets its specifications)	Check/reseat that cable between the Calibrator Assembly and the Main Board Attempt to adjust the 1 mW Power Reference Level	Calibrator assembly (high probability) Main board (low probability)
Fan	Verifies that the fan is working	Check/reseat the cable between the Fan Assembly and the Main Board Check visually to see whether or not the Fan is working	Fan assembly (high probability) Main Board (low probability)
Battery	Checks that the lithium manganese battery on the main board is working	Replace the battery to see if this clears the fault	Lithium manganese battery (high probability) Main board (low probability)
Peak path/ChA peak path	Verifies that the peak path of channel A is working (Note: This does not prove that the peak path meets its specifications)	Replace the DAP Assembly for Channel A to see if this clears the fault	DAP assembly, channel A (low probability) Main board (low probability)
CW path/ChA CW path	Verifies that the average path of channel A is working (Note: This does not prove that the average path meets its specifications)	Not applicable	Main board
DAP check/ChA DAP check	Executes an internal self-test procedure on the DAP Assembly for channel A	Replace the DAP assembly for channel A to see if this clears the fault	DAP assembly, channel A (high probability) Main board (low probability)
ChB peak path	Verifies that the peak path of channel B is working (Note: This does not prove that the peak path meets its specifications)	Replace the DAP assembly for channel B to see if this clears the fault	DAP assembly, channel B (low probability) Main board (high probability)

ChB CW path	Verifies that the average path of channel B is working (Note: This does not prove that the average path meets its specifications)	Not applicable	Main board
ChB DAP check	Executes an internal self-test procedure on the DAP assembly for channel B	Replace the DAP assembly for channel B to see if this clears the fault	DAP assembly, channel B (high probability) Main board (low probability)

Extended Self-Test

Instrument	Purpose	Debug Tips	Possible Faults
Keyboard	Verifies the operation of every key (apart from the power button)	Not applicable	Front panel (defective keymat or key flex circuit)
Bitmap display	Verifies that all pixels in the display can be illuminated in various colors	Not applicable	Front panel (defective display, display interface board, or inverter board)
Time base	Provides a means to measure time base frequency accuracy	Check that the BNC cable being used is not damaged Check that the BNC is connected to 'Trig Out', not 'Trig In'	Main Board

Performance Test

Type of Failures	Debug Tips	Possible Faults
1 mW power reference level failures	Attempt to adjust the 1 mW power reference level	Calibrator assembly (high probability) Main board (low probability)
VSWR failures	Not applicable	Calibrator assembly
Time base frequency accuracy failures	Check that the BNC cable being used is not damaged Check that the BNC is connected to 'Trig Out', not 'Trig In'	Main board
Zero set (average Path) failures	Not applicable	Main board
Zero set (peak path) failures	Not applicable	Main board
Linearity (average path) failures	Not applicable	Main board
Linearity (peak path) failures	Replace the DAP assembly for the channel to see if this clears the fault	DAP assembly (low probability) main board (high probability)
Rise/fall time (peak path) failures	Check/reseat the sensor flex RF connections	Sensor flex assembly (low probability) DAP assembly (low probability) Main board (high probability)

Power Reference Level Adjustment Problems

Possible Faults

- Calibrator assembly (high probability)
- Main board (low probability)

Communication Interface Failures

Type of Communication	Debug Tips	Possible Faults
GPIB communication	Check/reseat the ribbon cable connecting the PPMC to the main board	Ribbon cable (low probability) PPMC assembly (low probability) Main board (high probability)
LAN/USB communication	Check visually to see whether or not the connector is obstructed/damaged	PPMC assembly

Additional Diagnostic Tests

Type of Functionality	Reason	Recommended Test Method	Possible Faults
USB/LAN functionality	The N7832A software only tests functionality over GPIB	Check the DUT responds when *RST is sent to it via the USB/LAN interfaces	PPMC assembly
Sensor functionality	The N7832A software does not prove both paths of the sensor flex assembly	Connect an E4412A sensor to the DUT and ensure it can be zeroed/calibrated	Sensor flex assembly



6 Repair Guide

Introduction	60
Replaceable Parts	61
Front Panel Assembly	61
Main Board Assembly	69
PPMC (Processor PCI Mezzanine) Assembly	70
DAP (Digital Acquisition & Processing) Assembly	71
PSU (Power Supply Unit)	72
Rear Panel Assembly	73
Additional Spare Parts	76
Calibrator Assembly	77
Outer Housing Components	78
Sundries	80
Tools Required	81
Required Torque Values for Fasteners	82
Disassembly Instructions	83
Reassembly Instructions	91
Disassembly vs Part Replacement	94
Front Panel Disassembly Instructions	97
Front Panel Reassembly Instructions	102
Additional Repair Notes	107
Replacing the PPMC Assembly	109
Replacing the Calibrator Semi-Rigid/Split Ferrite	110

This chapter details the power meter's replaceable parts. It also explains how to assemble and disassemble the power meter.



Introduction

This chapter contains details of some of the higher level components and assemblies which can be ordered from Agilent Technologies. It also details how to assemble and disassemble the power meter for repair. The contents included are:

- 1 Replaceable Parts
- 2 Tools Required
- 3 Disassembly Instructions
- 4 Reassembly Instructions
- 5 Disassembly vs Part Replacement
- 6 Front Panel Disassembly Instructions
- 7 Front Panel Reassembly Instructions
- 8 Additional Repair Notes
- 9 Replacing the PPMC Assembly
- 10 Replacing the Calibrator Semi-Rigid/Split Ferrite

To order parts contact your local Agilent Technologies Sales and Service Office.



To return your power meter for servicing at a qualified service center refer to [Chapter 7](#), “Contacting Agilent Technologies”.

Replaceable Parts

Front Panel Assembly

Main Assembly

The standard P-Series power meter has the reference calibrator at the front panel. Option is available to move the reference calibrator to rear panel.

Agilent Part Number	Description	Visual
N1912-61804	Front panel assembly (front calibrator option)	
N1912-61805	<p>Front panel assembly (rear calibrator option)</p> <p>Note:</p> <ul style="list-style-type: none"> The front panel assembly must be customized to suit the hardware configuration of the unit being repaired Refurbished front panel assemblies are not available 	



Customization Details



The standard P-Series power meters have the input sensor connector(s) and reference calibrator connector on the front panel. Option 003 is available to move the input sensor connector(s) and reference calibrator connector to the rear panel. Below are the customization details on front panel assembly.

Connector Option	Details	Part Number
N1911A (front connectors option)	1 unit of sensor flex assembly 1 unit of calibrator plug 1 unit of front panel plug (large) 1 unit of N1911A front panel dress label 1 unit of N1911A nameplate	N1912-61806 N1912-21003 N1912-21004 N1912-00026 N1911-80001
N1911A (front connectors option)	2 unit of front panel plug (large) 1 unit of front panel Plug (small) 1 unit of blank front panel dress label 1 unit of N1911A nameplate	N1912-21004 N1912-21005 N1912-00025 N1911-80001
N1912A (front connectors option)	2 unit of sensor flex assembly 1 unit of calibrator plug 1 unit of N1912A front panel dress label 1 unit of N1912A nameplate	N1912-61806 N1912-21003 N1912-00027 N1912-80003
N1912A (front connectors option)	2 unit of front panel plug (large) 1 unit of front panel plug (small) 1 unit of blank front panel dress label 1 unit of N1912A nameplate	N1912-21004 N1912-21005 N1912-00025 N1912-80003

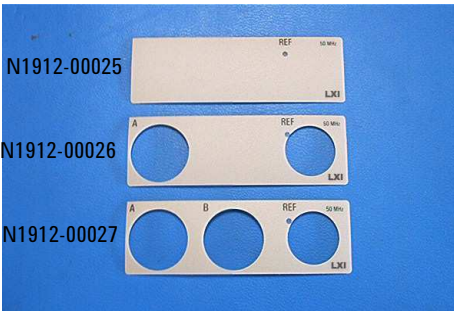

Photos on items above are available in next section.

Customization Parts

Agilent Part Number	Description	Visual
N1912-61806	<p>Sensor flex assembly</p> <p>Note:</p> <ul style="list-style-type: none"> • The same assembly is used for all four sensor positions • The kit includes a spacer, required for fitting the flex to the rear panel • The sensor flex assembly is supplied straight, and so it must be folded to match the assembly being replaced (see “Additional Repair Notes” on page 107) 	
N1912-21003	Calibrator plug	
N1912-21005	Front panel plug (small)	

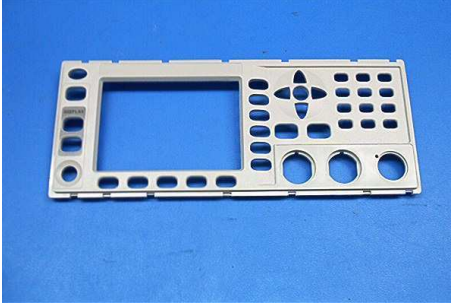
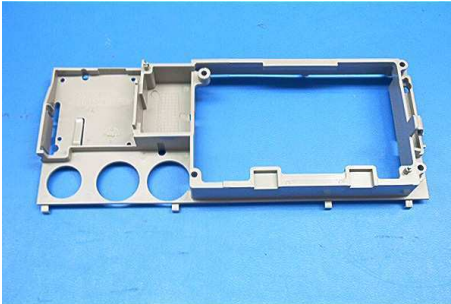

Agilent Part Number	Description	Visual
<p>N1912-00025</p> <p>N1912-00026</p> <p>N1912-00027</p>	<p>Blank front panel dress label</p> <p>N1911A front panel dress label</p> <p>N1912A front panel dress label</p>	 <p>The image shows three Agilent front panel dress labels. The top label, N1912-00025, is a blank white rectangular label with 'REF' and '50 MHz' printed on the right side. The middle label, N1912-00026, is a white rectangular label with two circular cutouts labeled 'A' and 'B', and 'REF' and '50 MHz' printed on the right side. The bottom label, N1912-00027, is a white rectangular label with three circular cutouts labeled 'A', 'B', and 'C', and 'REF' and '50 MHz' printed on the right side.</p>
<p>N1911-80001</p> <p>N1912-80003</p>	<p>N1911A nameplate</p> <p>N1912A nameplate</p>	 <p>The image shows two Agilent nameplates. The top nameplate, N1911-80001, is a white rectangular label with the Agilent logo, 'Agilent N1911A P-Series Power Meter' printed on it. The bottom nameplate, N1912-80003, is a white rectangular label with the Agilent logo, 'Agilent N1912A P-Series Power Meter' printed on it.</p>

Replaceable Parts

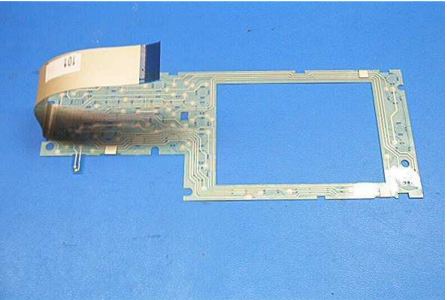
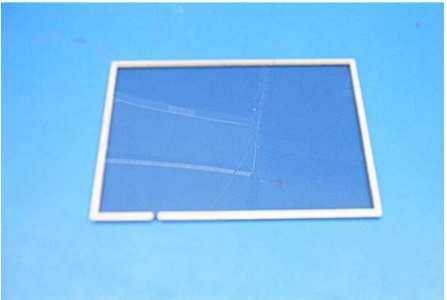
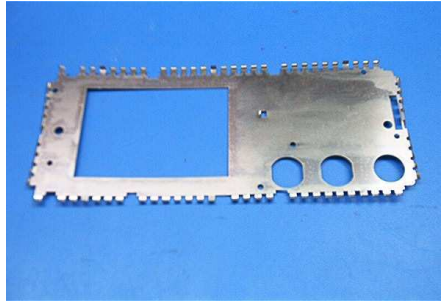

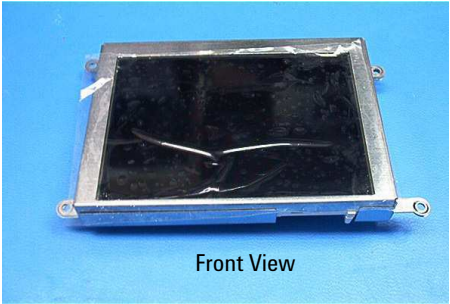
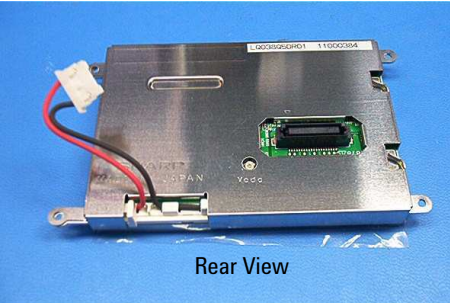
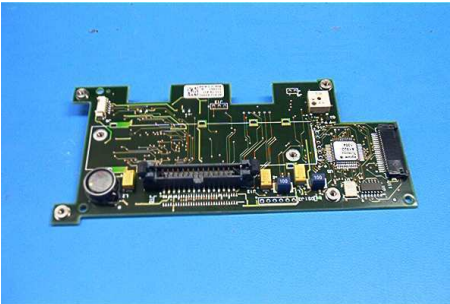
Agilent Part Number	Description	Visual
N1912-40003	<p>Front panel sub-frame</p> <p>Note:</p> <ul style="list-style-type: none"> This front panel sub-frame is used on all variants of the front panel assembly 	 <p>A silver-colored metal sub-frame for a front panel, featuring a large rectangular cutout on the left side and a control panel area on the right with a directional pad and several buttons.</p>
N1912-40002	<p>Display support molding</p> <p>Note:</p> <ul style="list-style-type: none"> This display support molding is used on all variants of the front panel assembly 	 <p>A silver-colored metal molding piece designed to support a display screen, with a large rectangular opening and several mounting points.</p>
N1912-40001	<p>Keymat</p> <p>Note:</p> <ul style="list-style-type: none"> This keymat is used on all variants of the front panel assembly 	 <p>A keymat assembly with a central display area and a control panel on the right side containing various buttons and a directional pad.</p>

Agilent Part Number	Description	Visual
N1912-20001	<p>Key flex circuit</p> <p>Note:</p> <ul style="list-style-type: none"> This key flex circuit is used on all variants of the front panel assembly 	 <p>A photograph of a key flex circuit component. It consists of a rectangular metal frame with a central cutout, connected to a flexible printed circuit (FPC) strip. The FPC strip has a gold-colored surface and a blue adhesive layer. The component is shown against a blue background.</p>
N1912-20005	<p>EMI shielded window</p> <p>Note:</p> <ul style="list-style-type: none"> This EMI shielded window is used on all variants of the front panel assembly 	 <p>A photograph of an EMI shielded window component. It is a rectangular metal frame with a central cutout, similar in shape to the key flex circuit. The component is shown against a blue background.</p>
N1912-00002	<p>EMI Screen</p> <p>Note:</p> <ul style="list-style-type: none"> This EMI screen is used on all variants of the front panel assembly 	 <p>A photograph of an EMI screen component. It is a rectangular metal frame with a central cutout and two circular holes on the right side. The component is shown against a blue background.</p>

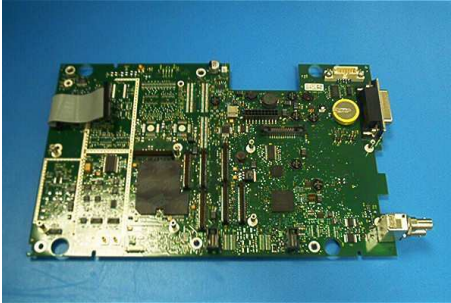

Agilent Part Number	Description	Visual
2090-0825	<p>Display</p> <p>Note:</p> <ul style="list-style-type: none"> This display is used on all variants of the front panel assembly 	 <p style="text-align: center;">Front View</p>  <p style="text-align: center;">Rear View</p>
N1912-60002	<p>Display interface board</p> <p>Note:</p> <ul style="list-style-type: none"> This display interface board is used on all variants of the front panel assembly 	

Agilent Part Number	Description	Visual
0950-4111	<p>Inverter board</p> <p>Note:</p> <ul style="list-style-type: none"> This inverter board is used on all variants of the front panel assembly 	
N1912-61002	<p>Backlight cable assembly</p> <p>Note:</p> <ul style="list-style-type: none"> This backlight cable assembly is used on all variants of the front panel assembly 	
N1912-00038	<p>Split washer</p> <p>Note:</p> <ul style="list-style-type: none"> This split washer is used on all variants of the front panel assembly 	

Main Board Assembly

Agilent Part Number	Description	Visual
N1911-61801	N1911A main board assembly [new]	
N1912-61801	<p>N1912A main board assembly [new]</p> <p>Note:</p> <ul style="list-style-type: none"> • Refurbished main boards are not available • The part number for the lithium manganese battery (Upper- right of both photographs) is 1420-0394 	

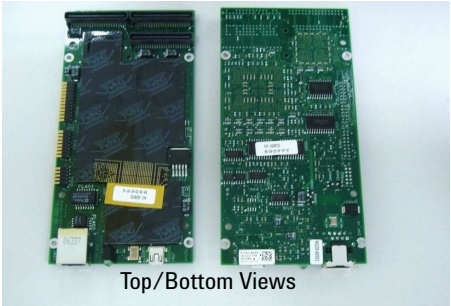
PPMC (Processor PCI Mezzanine) Assembly

Agilent Part Number	Description	Visual
<p>N1911-61802</p>	<p>PPMC PCA</p> <p>Note:</p> <ul style="list-style-type: none"> • The same assembly is used for both N1911A and N1912A models • N1911-66500 (single channel PPMC PCA) comes pre-programmed with N1911A firmware • N1912-66500 (dual channel PPMC PCA) comes pre-programmed with N1912A firmware • Refurbished PPMC assemblies are not available • The PPMC assembly must be programmed once it has been installed (see “Additional Repair Notes” on page 107) • Ribbon cable 8121-1076 is supplied separately. 	 <p>Top/Bottom Views</p>  <p>8121-1076</p>

DAP (Digital Acquisition & Processing) Assembly

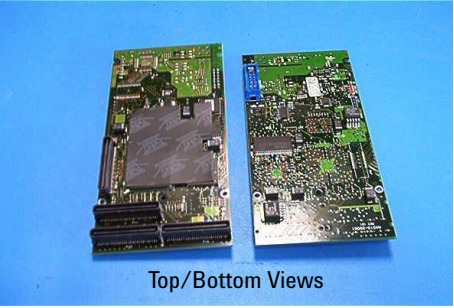
Agilent Part Number	Description	Visual
N1912-60004	<p>Measurement board</p> <p>Note:</p> <ul style="list-style-type: none"> • The same assembly is used for both N1911A and N1912A models • Two identical DAP assemblies are fitted to the N1912A model • Refurbished DAP assemblies are not available 	 <p>Top/Bottom Views</p>

PSU (Power Supply Unit)

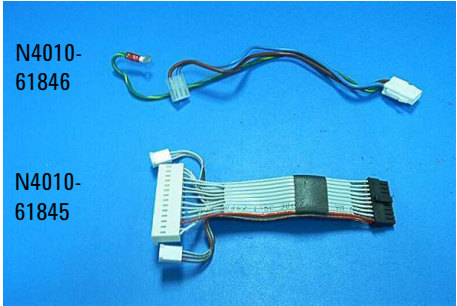
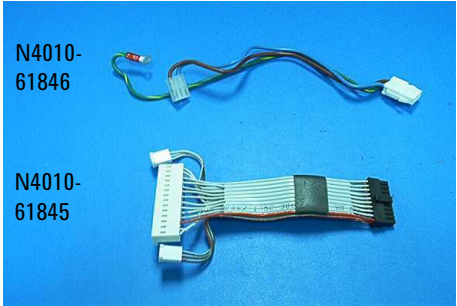
Agilent Part Number	Description	Visual
<p>N4010-61848</p>	<p>PSU [new]</p> <p>Note:</p> <ul style="list-style-type: none"> • The same assembly is used for both N1911A and N1912A models • Refurbished PSUs are not available • Cables N4010-61846 and N4010-61845 are supplied separately 	 <p>The image shows a black PSU assembly mounted on a green printed circuit board. It features a transformer, various electronic components, and a label with technical specifications and safety warnings.</p>  <p>The image shows a thin, multi-colored ribbon cable with a white plastic connector on one end and a multi-pin connector on the other.</p>  <p>The image shows a wider, multi-colored ribbon cable with a white plastic connector on one end and a multi-pin connector on the other.</p>

Rear Panel Assembly

Main Assembly

Agilent Part Number	Description	Visual
N1912-61007	Rear panel assembly [new]	 <p data-bbox="896 734 1165 760">N1912-61007 / N1912-61031</p>
N1912-61031	Revised rear panel assembly [new] Note: <ul style="list-style-type: none"> • The rear panel assembly must be customized to suit the hardware configuration of the unit being repaired • Refurbished rear panel assemblies are not available • Parts N1912-61007 and N1912-61031 differ slightly with regards to the connector cutout positions • The revision of the main board can be used to help determine which rear panel assembly is in use (see “Additional Repair Notes” on page 107) • The same assemblies are used for both N1911A and N1912A models 	

Customization Details



The standard P-Series power meters have the input sensor connector(s) and reference calibrator connector on the front panel. Option 003 is available to move the input sensor connector(s) and reference calibrator connector to the rear panel. Below are the customization details on rear panel assembly.

Connector Option	Details	Part Number
N1911A (Front connectors option)	1 unit of rear panel plug (BNC) 2 unit of rear panel plug (Sensor) 1 unit of rear panel plug (Calibrator)	6960-0081 6960-0024 6960-0178



Connector Option	Details	Part Number
N1911A (front connectors option)	1 unit of sensor flex assembly 1 unit of N-Type connector 1 unit of lock washer 1 unit of hex nut 1 unit of washer 1 unit of rear panel plug (BNC) 1 unit of rear panel plug (Sensor)	N1912-61806 E4418-20009 E4418-00016 2950-0132 3050-0916 6960-0081 6960-0024
N1912A (front connectors option)	1 unit of Recorder Output Cable 2 unit of rear panel plug (Sensor) 1 unit of rear panel plug (Calibrator)	E4418-61015 6960-0024 6960-0178
N1912A (front connectors option)	2 unit of sensor flex assembly 1 unit of N-Type connector 1 unit of lock washer 1 unit of hex nut 1 unit of washer 1 unit of recorder output cable	N1912-61806 E4418-20009 E4418-00016 2950-0132 3050-0916 E4418-61015

Customization Parts

Agilent Part Number	Description	Visual
E4418-20009	N- Type connector	
E4418-00016	Lock washer	
2950-0132	Hex nut	
3050-0916	Washer	

Agilent Part Number	Description	Visual
N1912-61806	Sensor flex assembly	
E4418-61015	Recorder output cable	
6960-0081 6960-0024 6960-0178	Rear panel plug (BNC) Rear panel plug (sensor) Rear panel plug (calibrator)	<p>(Two Views Shown For Each Part)</p>  <p>6960-0178 6960-0024 6960-0081</p>

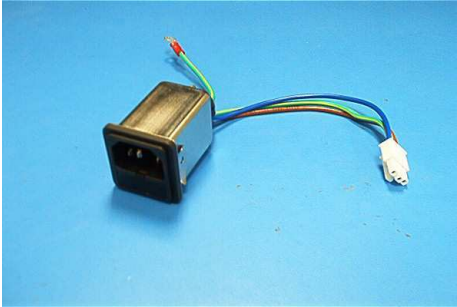
Additional Spare Parts

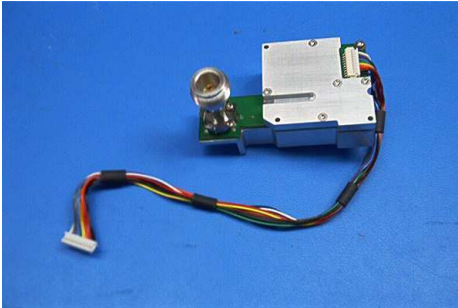
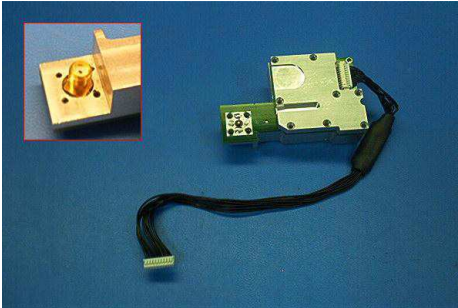

Agilent Part Number	Description	Visual
N1912-61036	Line module	
N4010-21025	Service connector cable	

Calibrator Assembly

Agilent Part Number	Description	Visual
N1911-61001	Calibrator assembly (front connectors option)	
N1911-61002	<p>Calibrator assembly (rear connectors option)</p> <p>Note:</p> <ul style="list-style-type: none"> Semi-rigid cable N1912-61004 is not included with assembly N1911-61002; if this is required, it is available as a separate item 	

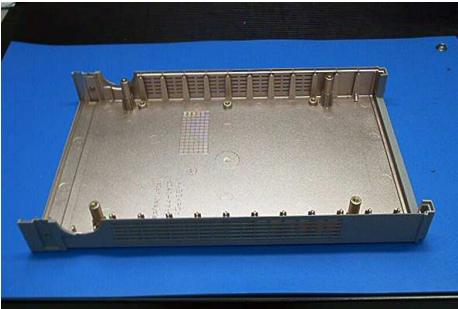
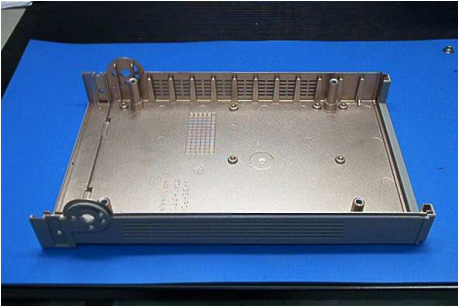
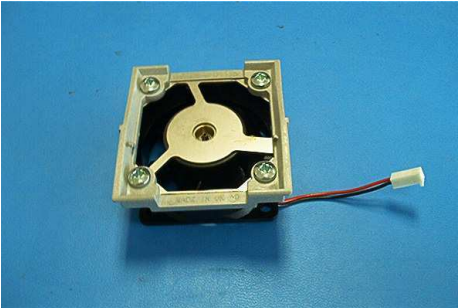
Outer Housing Components

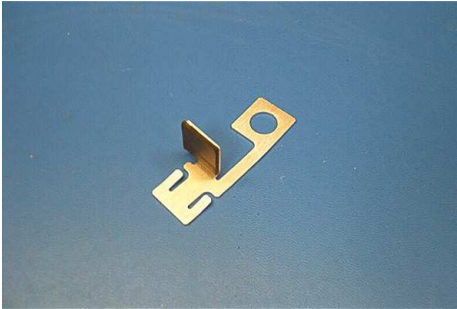
Agilent Part Number	Description	Visual
5041-7717	Clamshell (top)	 <p>A photograph of the top clamshell component, a rectangular metal frame with a central grid and various mounting points, resting on a blue surface.</p>
5041-7718	Clamshell (bottom)	 <p>A photograph of the bottom clamshell component, similar to the top one but with a different internal structure and mounting points, resting on a blue surface.</p>
N1912-61005	Fan assembly	 <p>A photograph of the fan assembly, a small square component with a central fan and a four-pin connector, resting on a blue surface.</p>

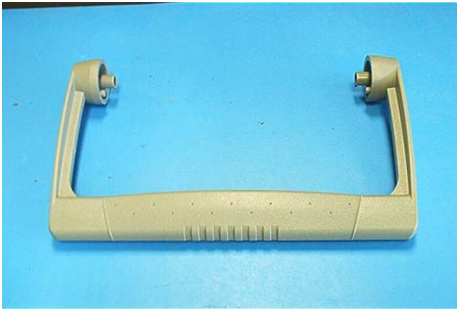
Agilent Part Number	Description	Visual
N1912-61025	Cable clamp	
34401-86020	Bumper kit	
34401-45021	Handle	

Sundries

Agilent Part Number	Description	Visual
N1911-61004 N1912-80005	Calibrator semi-rigid cable (rear option) Split ferrite Note: <ul style="list-style-type: none"> If the semi-rigid cable is replaced, then the split ferrite must be positioned correctly (see "Additional Repair Notes" on page 107) 	 <p>N1911-61004 (with N1912-80005)</p>
2110-0957	Line module fuse, 3.15A/250V (non-time-delayed)	

Tools Required

Agilent Part Number	Description	Visual
<p>N1911-61004</p> <p>N1912-80005</p>	<ul style="list-style-type: none"> • 3 unit of ¼” drive torque wrenches <ul style="list-style-type: none"> • 1 unit of calibrated to 2.37 Nm (21 lb-in) • 1 unit of calibrated to 1.02 Nm (9 lb-in) • 1 unit of calibrated to 0.68 Nm (6 lb-in) • 3 unit of torque screwdrivers <ul style="list-style-type: none"> • 1 unit of calibrated to 2.37 Nm (21 lb-in) • 1 unit of calibrated to 0.56 Nm (5 lb-in) • 1 unit of calibrated to 0.34 Nm (3 lb-in) • T6, T8, T10, & T20 Torx screwdriver bits • 7/16” break spanner, calibrated to 2.37 Nm (21 lb- in) • 5/16” break spanner, calibrated to 1.02 Nm (9 lb- in) • 9/32” socket 	
<p>N1912-61807</p>	<p>Special tooling kit</p> <ul style="list-style-type: none"> • Contains: <ul style="list-style-type: none"> • ODU socket • Trigger socket • 9/16” BNC socket • Sockets must be used in conjunction with a ¼” drive torque wrench, calibrated to 2.37 Nm (21 lb-in) • The 9/16” BNC socket is required to remove the Trig In/Out fasteners for the majority of N1911A/12A power meters • The trigger socket is required to remove the Trig In/Out fasteners for a minority of N1911A/12A power meters 	 <p>ODU Socket Trigger Socket 9/16” BNC Socket</p>

Required Torque Values for Fasteners

Required tools and torque values for fasteners are listed below:

Item	Description/Default	Range of Values
Fit rear panel GPIB standoffs	9/32" socket	0.68 Nm
Fit rear panel Trig In/Out connectors	Special tooling kit (N1912-61807)	2.37 Nm
Fit rear panel recorder output connectors	7/16" spanner	2.37 Nm
Attach main board to clamshell	T20 screwdriver	2.37 Nm
Attach PPMC/DAP assemblies to main board	T8 screwdriver	0.56 Nm
Fit calibrator semi-rigid, both ends (Option 003)	5/16" spanner	1.02 Nm
Attach earth wires (Nut)	9/32" socket	1.02 Nm
Attach earth wires (Screw)	T20 screwdriver	2.37 Nm
Attach top clamshell to bottom clamshell	T20 screwdriver	2.37 Nm
Fit sensor connector	Special tooling kit (N1912-61807)	2.37 Nm
Fit PSU/PSU safety cover	T10 screwdriver	2.37 Nm
Fit display to display support moulding	T6 screwdriver	0.56 Nm
Fit calibrator to display support moulding	T6 screwdriver	0.34 Nm
Fit display interface board to inverter board	T6 screwdriver	0.56 Nm

Disassembly Instructions

The guidelines in this section describe the disassembly of the major assembling in the Agilent N1911A and N1912A power meters.

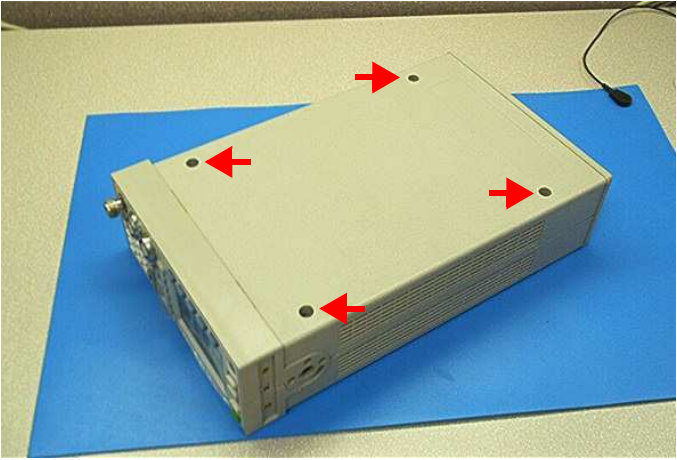
Instructions	Visual
<ul style="list-style-type: none"> This procedure focuses primarily on model N1912A, Option 101 (i. e. dual channel, with front panel sensor and power reference connectors) Additional information is provided to assist in the disassembly of Option 003 units (i. e. with rear panel sensor and power reference connectors) 	 <p style="text-align: center;">N1912A, Option 101</p> <p style="text-align: center;">N1911A, Option 003</p>
<ul style="list-style-type: none"> Remove the handle: Rotate it to the vertical position. Pull both sides outwards from the body of the unit. Remove the front/rear bumpers: Pull one side of the bumper outwards to disengage it. Pull it away from the unit. Separate the clamshells (Figure 6-1): Use the T20 Torx screwdriver bit to loosen the 4 captive screws. 	 <p>Figure 6-1</p>

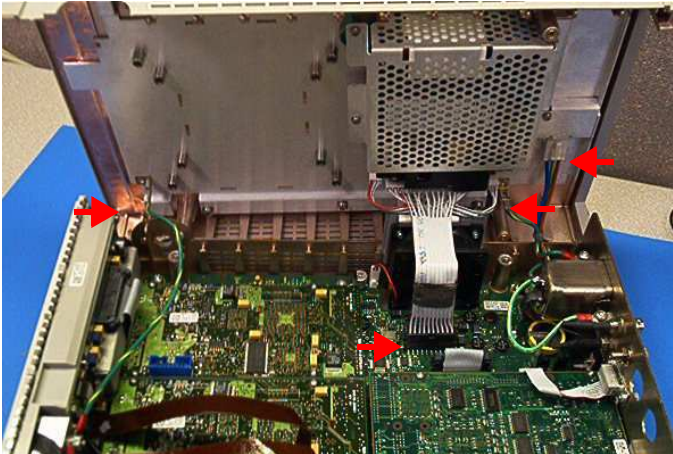
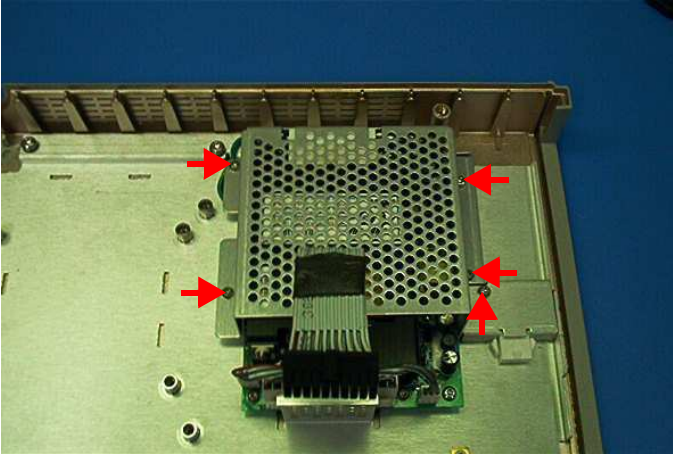
Instructions	Visual
<ul style="list-style-type: none"> Remove the top clamshell (Figure 6-2): Disconnect the mains power connector from the top clamshell. Disconnect the ribbon cable from the main board. Disconnect both earth spade connectors from the top clamshell. Remove top clamshell. 	 <p>Figure 6-2</p>
<ul style="list-style-type: none"> Remove the PSU safety cover (Figure 6-3): Use the T10 Torx screwdriver bit to remove the 4 screws attaching the PSU safety cover to the top clamshell. Lift and remove the safety cover. Remove the PSU cable guide (Figure 6-3): Use the T10 Torx screwdriver bit to remove the screw attaching the cable guide to the top clamshell. Lift and remove cable guide. 	 <p>Figure 6-3</p>

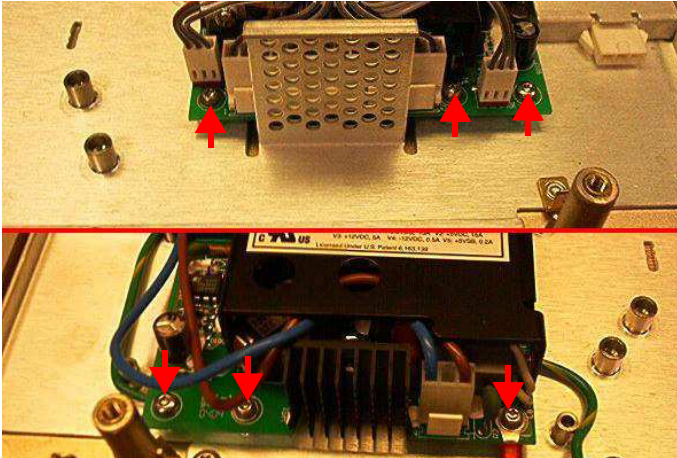
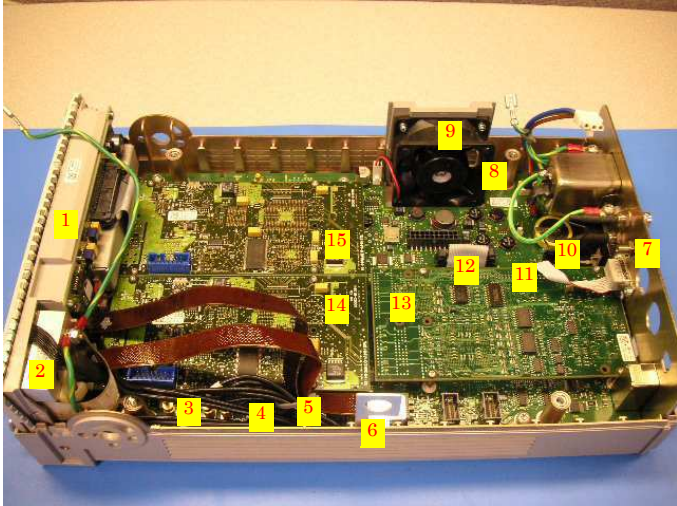
Instructions	Visual
<ul style="list-style-type: none"> Remove the PSU (Figure 6-4): Use the T10 Torx screwdriver bit to remove the 6 screws attaching the PSU to the top clamshell. Lift and remove the PSU. 	 <p>Figure 6-4</p>
<ul style="list-style-type: none"> Key to Figure 6-5 and Figure 6-6: <ol style="list-style-type: none"> 1 Front panel assembly 2 Calibrator assembly 3 Sensor RF connections 4 Sensor flex connection(s) 5 Calibrator cable connection 6 Cable clamp 7 Rear panel assembly 8 Line module 9 Fan assembly 10 Analog recorder output connection(s) 11 Service connector cable 12 Ribbon cable 13 PPMC assembly 14 DAP assembly (Channel A) 15 DAP assembly (Channel B) 	 <p>Figure 6-5</p>

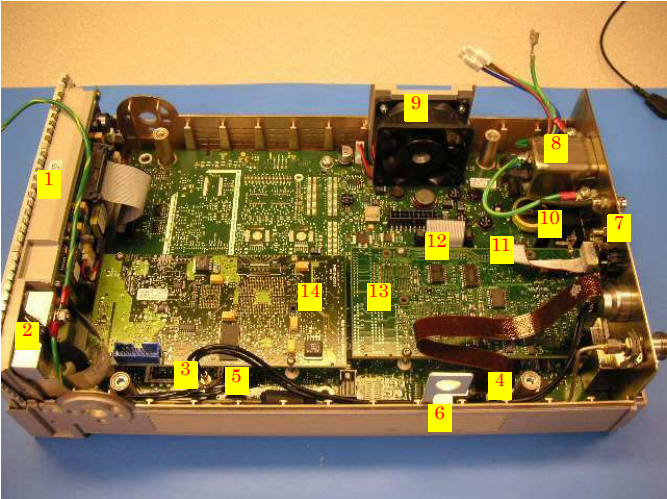
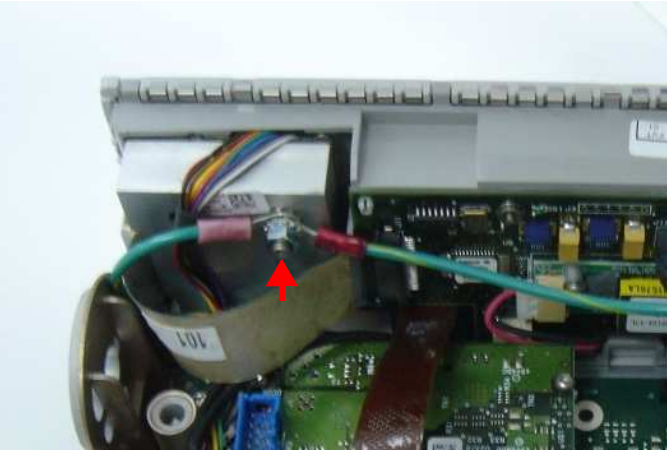
Instructions	Visual
<ul style="list-style-type: none"> • With reference to Figure 6-5 and Figure 6-6: • Lift and remove the cable clamp. • Disconnect the cable attaching the fan assembly to the main board. • Lift and remove the fan assembly • Disconnect the sensor RF connections from the main board. • Disconnect the sensor flex connection(s) from the main board. • Disconnect the calibrator cable connection from the main board. • Disconnect the analog recorder output connection(s) from the main board. 	 <p>Figure 6-6</p>
<ul style="list-style-type: none"> • Remove the EMI earth wires (Figure 6-7): Use the 9/32" Socket to remove the hex nut attaching the EMI earth wires to the calibrator assembly. Remove the earth wires and washers, taking note of the assembly order. 	 <p>Figure 6-7</p>

Instructions	Visual
<ul style="list-style-type: none"> Disconnect the front panel cable (Figure 6-8): Depress both sides of the connector holding the ribbon cable to eject it. 	 <p data-bbox="614 807 721 833">Figure 6-8</p>
<ul style="list-style-type: none"> Disconnect the semi-rigid cable (Figure 6-9): <p data-bbox="149 911 207 937">Note:</p> <ul style="list-style-type: none"> This only applies to Option 003 units. <p data-bbox="149 1015 578 1102">Use the 5/16" spanner to disconnect the semi-rigid cable from the N-Type connector on the rear panel.</p>	 <p data-bbox="614 1414 721 1440">Figure 6-9</p>

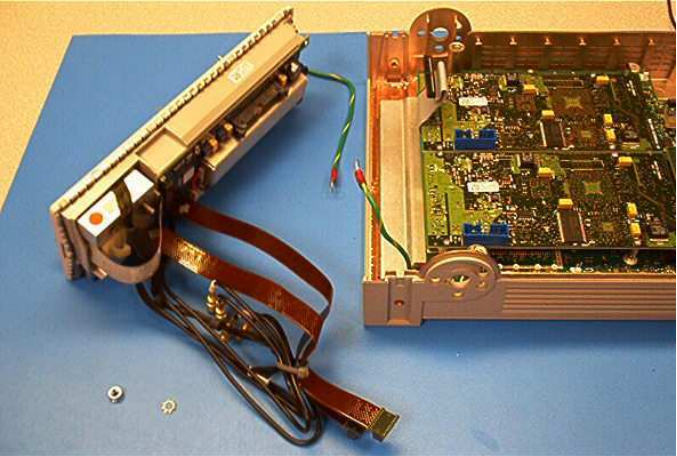
Instructions	Visual
<ul style="list-style-type: none">Remove the front panel (Figure 6-10): Carefully lift and remove the front panel assembly.	 <p data-bbox="611 822 733 850">Figure 6-10</p>
<ul style="list-style-type: none">Disconnect PPMC cables (Figure 6-5/Figure 6-6): Disconnect the service connector cable from the PPMC assembly. Disconnect the ribbon cable from the main board, whilst leaving it connected to the PPMC assembly.	

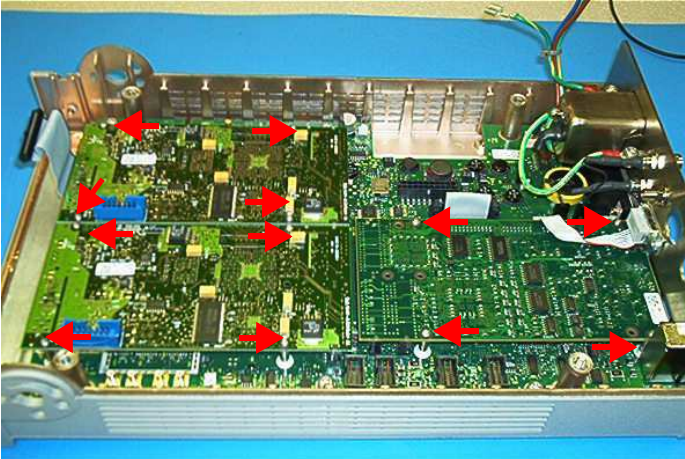
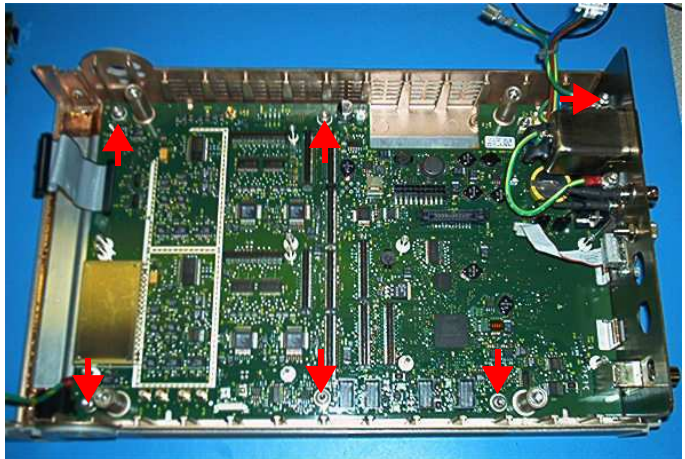
Instructions	Visual
<ul style="list-style-type: none"> Remove DAP/PPMC (Figure 6-11): Use the T8 Torx screwdriver bit to remove the screws attaching the DAP and PPMC assemblies to the main board. Carefully remove the PPMC assembly by lifting the end closest to the DAP assembly. Carefully remove each DAP assembly by lifting the end closest to the rear panel. 	 <p>Figure 6-11</p>
<ul style="list-style-type: none"> Remove the main board (Figure 6-12): Use the T20 Torx screwdriver bit to remove the 5 screws attaching the main board to the bottom clamshell. Use the T20 Torx screwdriver bit to remove the screw attaching the earth wires to the line module. Remove the earth wires and washers, taking note of the assembly order. Lift & remove the main board. 	 <p>Figure 6-12</p>

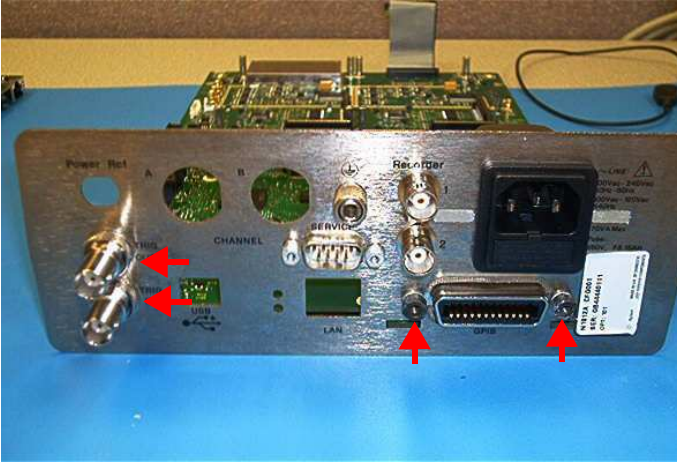
Instructions	Visual
<ul style="list-style-type: none"> Remove the rear panel (Figure 6-13): Use the N1912-61807 special tooling kit to remove the asteners on the trigger connectors. Use the 9/32" Socket to remove the GPIB standoffs. Carefully pull the rear panel away from the main board. 	 <p>The image shows the rear panel of a power meter. It features several ports and connectors: a Power Port, two Channel ports (A and B), a Service port, a Recorder port, a LAN port, a USB port, and a GPIB port. Red arrows point to the trigger connectors on the left, the LAN port, and the GPIB port. A label on the right side of the panel reads: 'N1911A-0001', 'SERIAL 000000011', and 'DATE 01/07'. The panel is mounted on a blue surface.</p> <p>Figure 6-13</p>

Reassembly Instructions

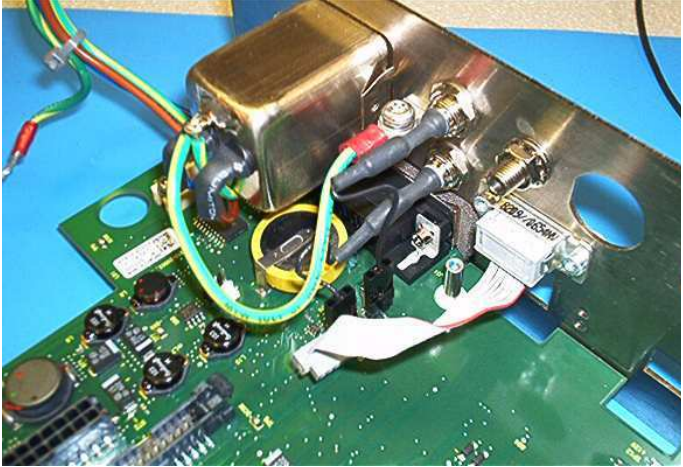
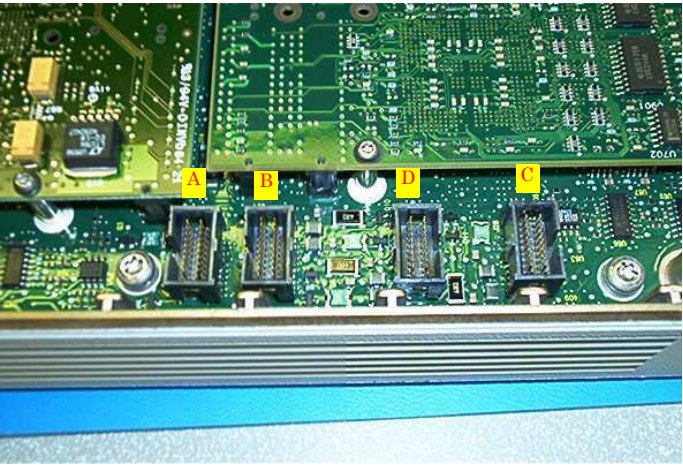
Instructions	Visual
<ul style="list-style-type: none"> • The reassembly process is simply the reverse of the disassembly process. However, there are various points to be aware of: <ul style="list-style-type: none"> • USB/LAN connectors must rest on top of the rear panels' EMC spring fingers. • The position of the cable clamp depends on whether option 101 or 003 is fitted. • The main board connector from the PSU must be pushed firmly to fully engage it. • Take care not to trap any cables when fitting the top clamshell. • Analog recorder output connections (Figure 6-14): Ensure recorder 1 is plugged into the rear connector. Where applicable, recorder 2 is plugged into the connector nearer the front. 	 <p data-bbox="608 899 728 927">Figure 6-14</p>
<ul style="list-style-type: none"> • Sensor flex connections (Figure 6-15): <ul style="list-style-type: none"> A – Front, Channel A (for Option 101) B – Front, Channel B (for Option 101) C – Rear, Channel A (for Option 003) D – Rear, Channel B (for Option 003) 	 <p data-bbox="608 1461 728 1489">Figure 6-15</p>

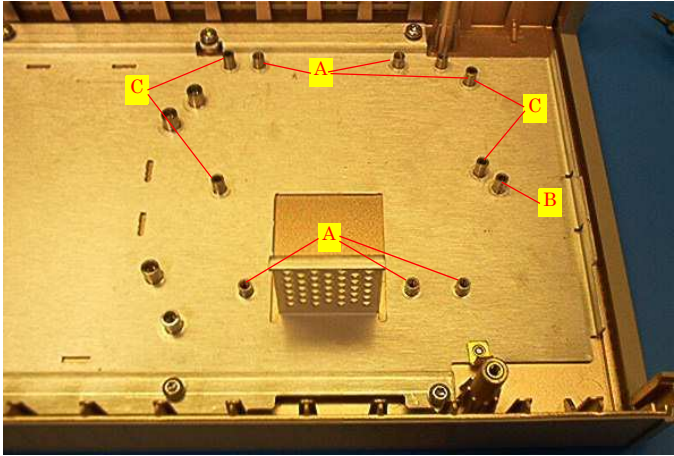
Instructions	Visual
<ul style="list-style-type: none"> • Sensor RF connections (Figure 6-16): E – Channel A(+), Black cable F – Channel A(-), Black/White cable G – Channel B(+), Black cable H – Channel B(-), Black/White cable <p>Note:</p> <ul style="list-style-type: none"> • Only connect E and F for N1911A • Connect E, F, G, H for N1912A 	 <p>Figure 6-16</p>
<ul style="list-style-type: none"> • PSU screw locations (Figure 6-17): A – Attach PSU to clamshell (6 screws) B – Attach PSU cable guide (1 screw) C – Attach PSU safety cover (4 screws) 	 <p>Figure 6-17</p>

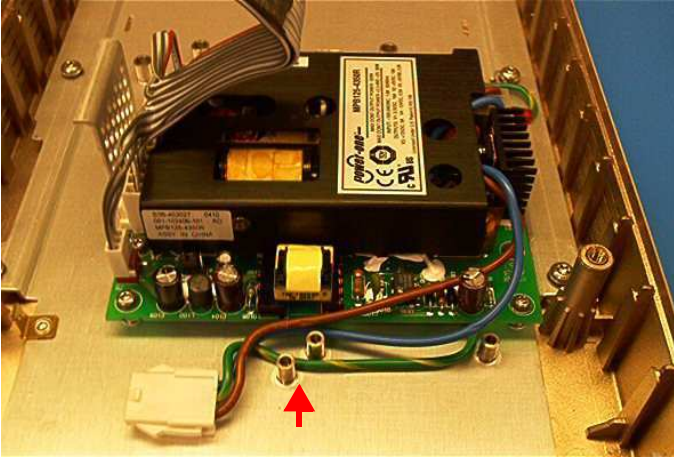
Instructions	Visual
<ul style="list-style-type: none">• PSU cable routing (Figure 6-18): Ensure the PSU cables are positioned such that the cable guide does not trap them or pinch them.	 <p data-bbox="606 835 729 864">Figure 6-18</p>

Disassembly vs Part Replacement

Disassembly of Replacement Part	Instructions
Main board / Rear panel assembly / Bottom clamshell	<ul style="list-style-type: none"> • Full strip-down required
PSU / Top clamshell	<ul style="list-style-type: none"> • Remove handle, bumpers, and top clamshell (including PSU) • PSU can now be removed from the top clamshell
Fan assembly	<ul style="list-style-type: none"> • Remove handle, bumpers, and top clamshell (including PSU) • Disconnect fan assembly from the main board • Fan assembly can now be removed
PPMC assembly (front connectors option)	<ul style="list-style-type: none"> • Remove handle, bumpers, and top clamshell (including PSU) • Disconnect the main board ribbon cable from the PPMC • Disconnect the service connector cable from the PPMC • Remove the 4 screws securing the PPMC to the main board • PPMC assembly can now be removed
PPMC assembly (rear connectors option)	<ul style="list-style-type: none"> • Remove handle, bumpers, and top clamshell (including PSU) • Disconnect the sensor flex connection(s) from the main board • Disconnect the main board ribbon cable from the PPMC • Disconnect the service connector cable from the PPMC • Remove the 4 screws securing the DAP assembly to the main board • PPMC assembly can now be removed
DAP assembly, Channel A (front connectors option)	<ul style="list-style-type: none"> • Remove handle, bumpers, and top clamshell (including PSU) • Disconnect the sensor RF connections from the main board • Disconnect the sensor flex connection(s) from the main board • Remove the 4 screws securing the DAP assembly to the main board • DAP assembly can now be removed



Disassembly of Replacement Part	Instructions
DAP assembly, Channel A (Rear connectors option)	<ul style="list-style-type: none"> • Remove handle, bumpers, and top clamshell (including PSU) • Disconnect the sensor RF connections from the main board • Remove the 4 screws securing the DAP assembly to the main board • DAP assembly can now be removed
DAP assembly, Channel B	<ul style="list-style-type: none"> • Remove handle, bumpers, and top clamshell (including PSU) • Remove the 4 screws securing the DAP assembly to the main board • DAP assembly can now be removed
Front panel assembly (front connectors option)	<ul style="list-style-type: none"> • Remove handle, bumpers, and top clamshell (including PSU) • Disconnect the sensor RF connections from the main board • Disconnect the sensor flex connection(s) from the main board • Disconnect the calibrator assembly cable connection from the main board • Disconnect the EMI earth wires from the calibrator assembly • Disconnect main board ribbon cable from the front panel • Front panel assembly can now be removed
Front panel assembly (rear connectors option)	<ul style="list-style-type: none"> • Remove handle, bumpers, and top clamshell (including PSU) • Disconnect calibrator semi-rigid from the rear panel assembly • Disconnect the calibrator assembly cable connection from the main board • Disconnect the EMI earth wires from the calibrator assembly • Disconnect main board ribbon cable from the front panel • Front panel assembly can now be removed
Sensor flex assembly (front connectors option)	<ul style="list-style-type: none"> • [Remove front panel assembly as previously described] • Use the N1912-61807 special tooling kit to remove the sensor flex assembly

Disassembly of Replacement Part	Instructions
Sensor flex assembly (rear connectors option)	<ul style="list-style-type: none">• Remove handle and front/rear Bumpers• Remove top clamshell (including PSU)• Disconnect the sensor RF connections from the main board• Disconnect the sensor flex connection from the Main Board• Use the N1912-61807 special tooling kit to remove the sensor flex assembly

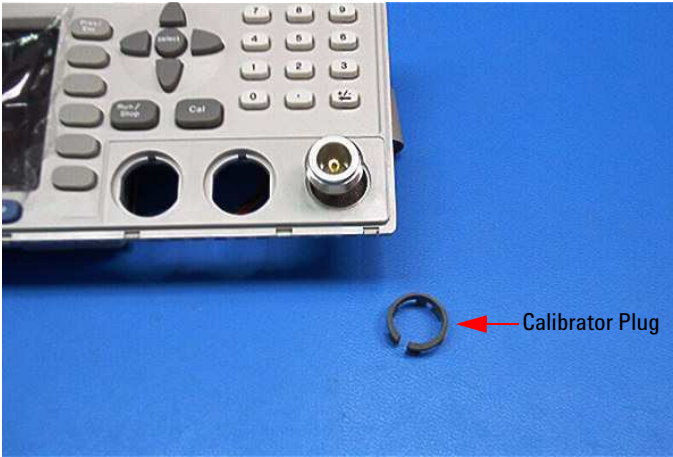
Front Panel Disassembly Instructions

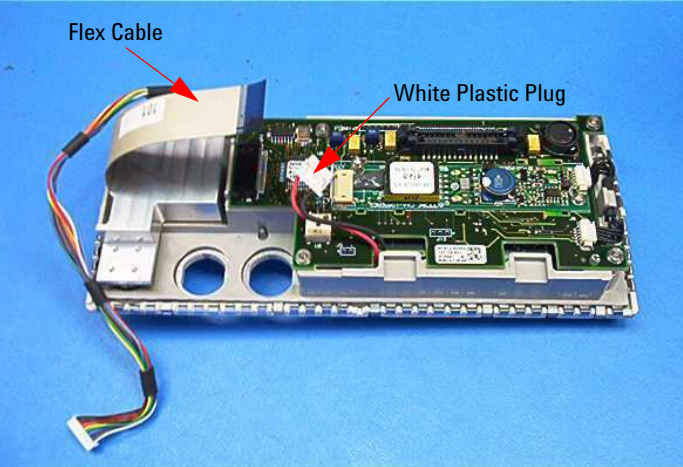
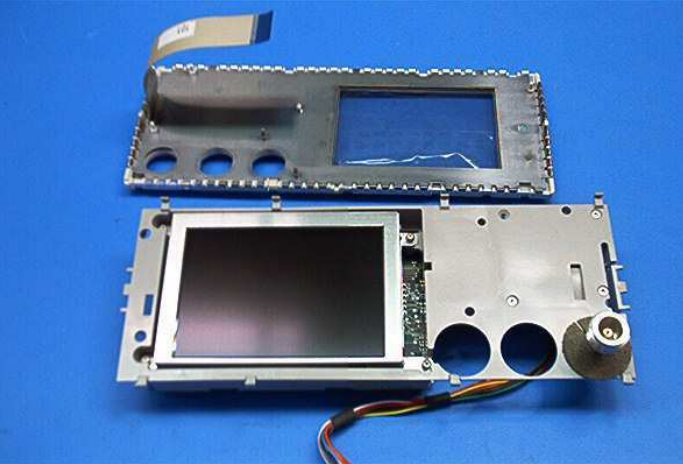
Instructions	Visual
<p>IMPORTANT NOTE:</p> <ul style="list-style-type: none"> • The front panel assembly should only be repaired in a clean and dust-free environment. • Failure to do so may introduce contamination between the EMI shielded window and the display. • Also note that it may not be necessary to completely disassemble the front panel in order to repair or replace some of its parts. As such, this procedure should be tailored to suit the specific repair requirements. 	
<p>Step 1:</p> <ul style="list-style-type: none"> • Carefully lift and remove the calibrator plug [This step does not apply to units with ear-panel connectors] Use ODU socket to remove N1912- 61806 sensor flex assembly 	

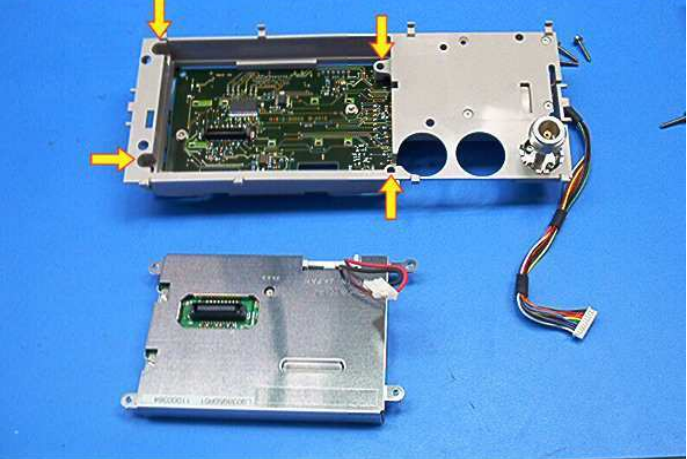

Instructions	Visual
<p>Step 2:</p> <ul style="list-style-type: none"> Release the tab holding the flex cable to the display interface board, and then disconnect it <p>Step 3:</p> <ul style="list-style-type: none"> Disconnect the white plastic plug from the display interface board 	 <p>The image shows a green printed circuit board (PCB) with various electronic components. A multi-colored flex cable is connected to the board. A white plastic plug is inserted into a connector on the board. Red arrows point to the flex cable and the white plastic plug. Labels 'Flex Cable' and 'White Plastic Plug' are placed above the respective components.</p>
<p>Step 4:</p> <ul style="list-style-type: none"> Unlock the main plastic clip that holds the front panel sub-frame and display support molding together (situated beside the key flex circuit), and carefully pull them apart to separate them 	 <p>The image shows two separate metal components. The top component is a front panel sub-frame with a rectangular cutout. The bottom component is a display support molding with a similar rectangular cutout and a small electronic component attached to its side. The two components are shown separated, illustrating the result of step 4.</p>

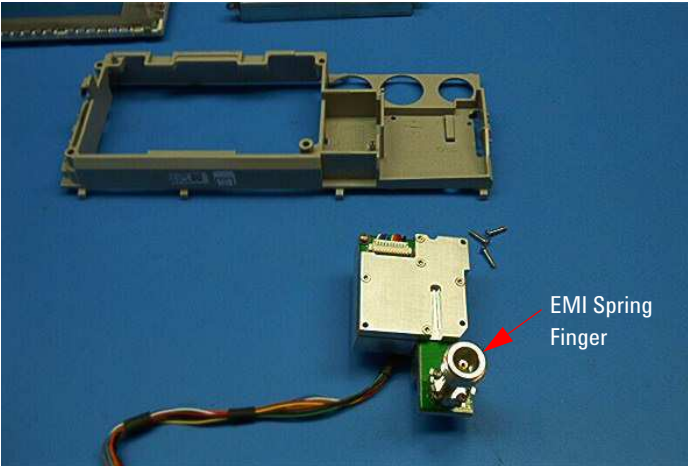
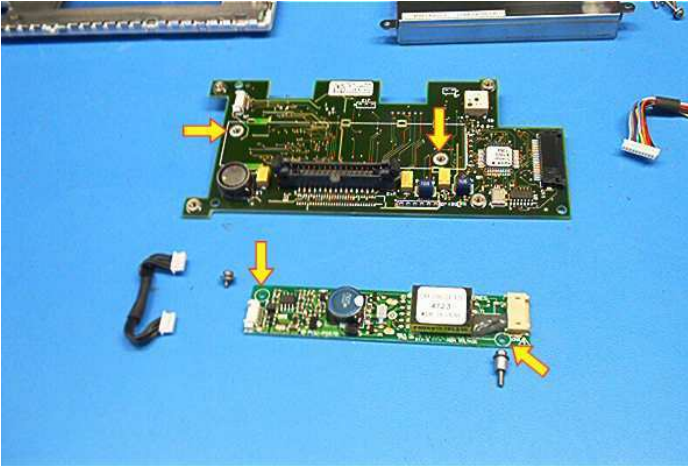
Instructions	Visual
<p>Step 5:</p> <ul style="list-style-type: none">Remove the 4 screws that attach the display to the display support molding, and then disconnect it from the display interface board	
<p>Step 6:</p> <ul style="list-style-type: none">Lift the display interface board off of the plastic mounting lugs on the display support molding to separate them from one another	

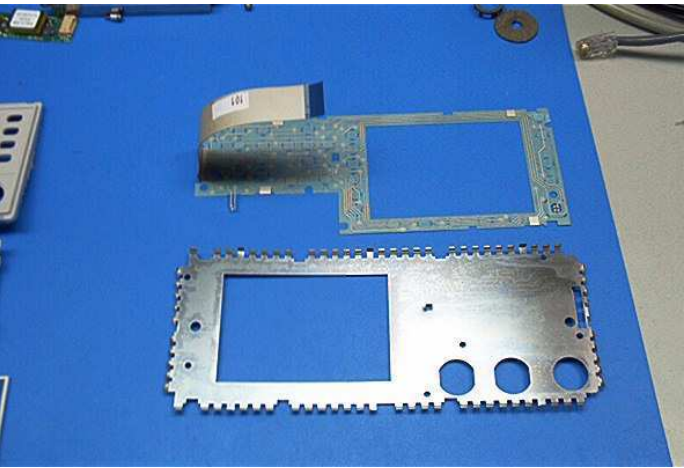
Instructions	Visual
<p>Step 7:</p> <ul style="list-style-type: none"> Remove the 3 screws that attach the calibrator assembly to the display support molding, and separate them from one another <p>Note:</p> <ul style="list-style-type: none"> Take care not to damage the EMI spring fingers on the calibrator assembly 	 <p>EMI Spring Finger</p>
<p>Step 8:</p> <ul style="list-style-type: none"> Disconnect the backlight cable assembly from the display interface board and inverter board <p>Step 9:</p> <ul style="list-style-type: none"> Remove the 2 screws that attach the display inter face board to the inverter board, and separate them from one another 	

Instructions	Visual
<p>Step 10:</p> <ul style="list-style-type: none">• Release the metal tabs holding the EMI screen to the front panel sub-frame, and separate them from one another <p>Step 11:</p> <ul style="list-style-type: none">• Disengage the rubber tabs that attach the key flex circuit to the keymat, and carefully lift it out	
<p>Step 12:</p> <ul style="list-style-type: none">• Remove the EMI shielded window and the keymat from the front panel sub-frame	

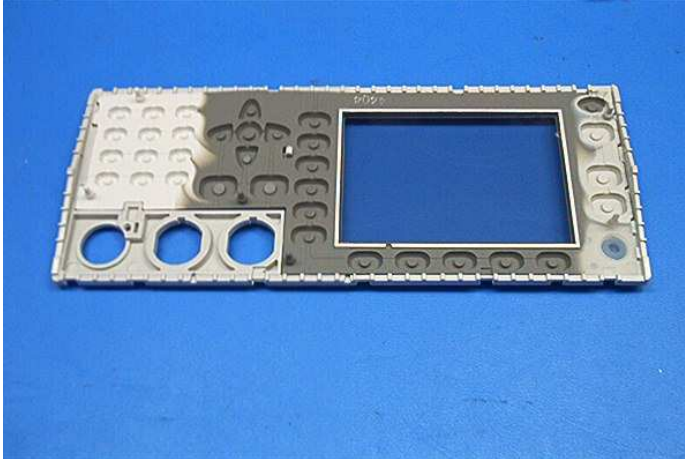

Front Panel Reassembly Instructions

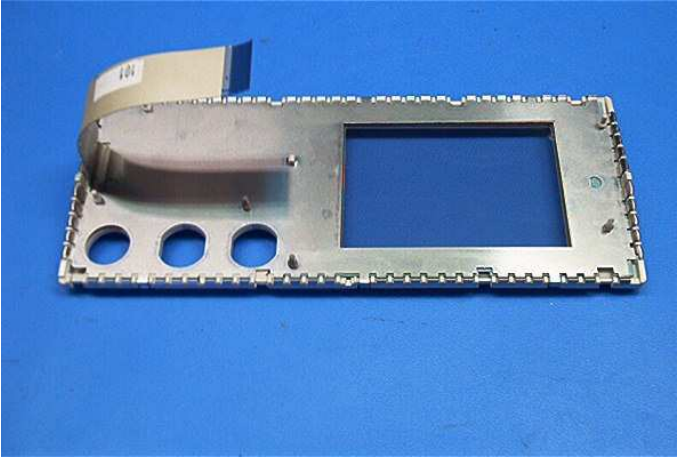
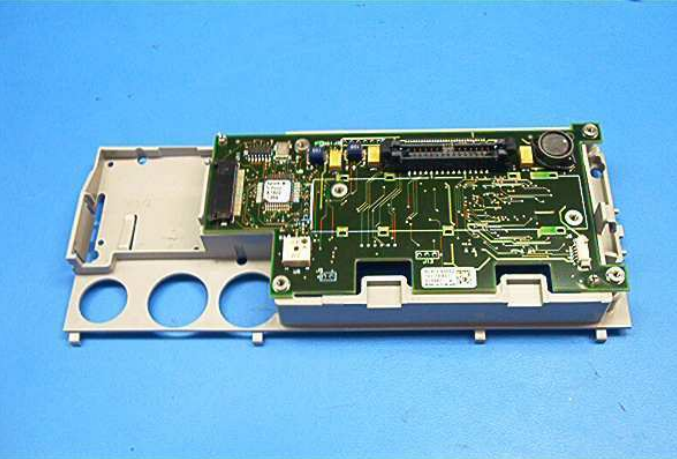
Instructions	Visual
<p>Step 1:</p> <ul style="list-style-type: none"> • Insert the keymat into the front panel Sub-Frame <p>Step 2:</p> <ul style="list-style-type: none"> • Insert the EMI shielded window into the keymat, ensuring that it is clean and free from fingerprints 	
<p>Step 3:</p> <ul style="list-style-type: none"> • Overlay the key flex circuit onto the keymat, ensuring that all of the rubber lugs are engaged to hold it securely 	

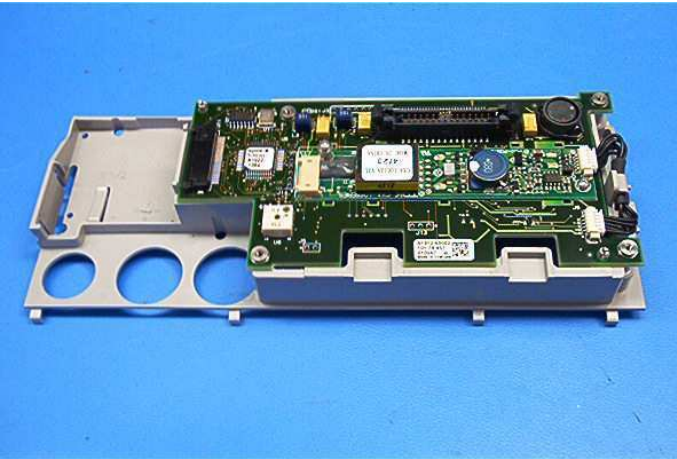
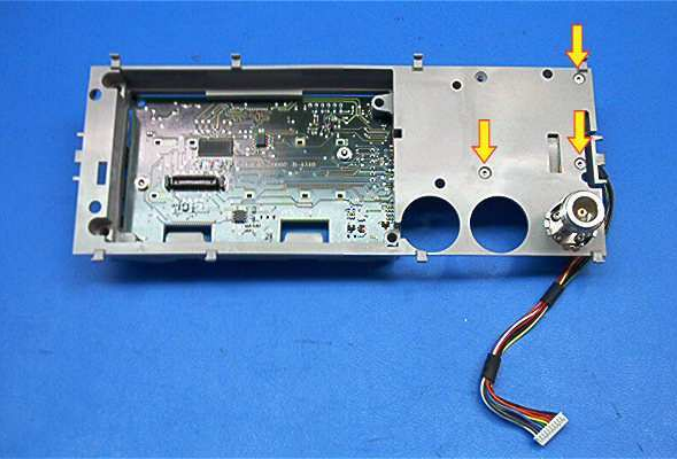
Instructions	Visual
<p>Step 4:</p> <ul style="list-style-type: none">• Overlay the EMI screen onto the key flex circuit, ensuring that all of the metal tabs are engaged to hold it securely	
<p>Step 5:</p> <ul style="list-style-type: none">• Fit the display interface board onto the plastic mounting lugs on the display support molding	

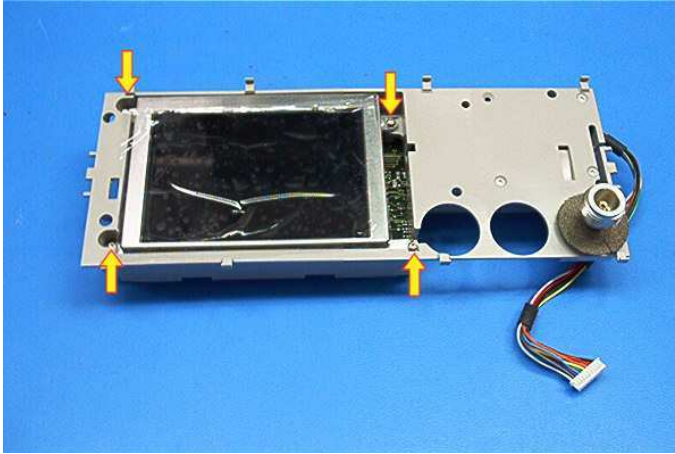
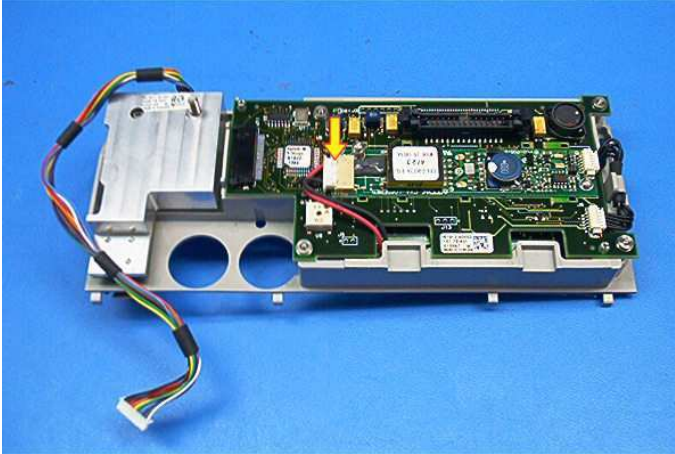
Instructions	Visual
<p>Step 6:</p> <ul style="list-style-type: none"> • Attach the inverter board to the display interface board using the 2 screws removed earlier <p>Step 7:</p> <ul style="list-style-type: none"> • Connect the inverter board to the display interface board using the backlight cable assembly <p>Note:</p> <ul style="list-style-type: none"> • The cable must be tucked under the plastic clip to prevent any fouling 	
<p>Step 8:</p> <ul style="list-style-type: none"> • Attach the calibrator assembly to the display support molding using the 3 screws removed earlier <p>Step 9:</p> <ul style="list-style-type: none"> • Carefully spread the EMI fingers outwards, ensuring they extend beyond the edges of the hole in which the calibrator assembly is fitted 	

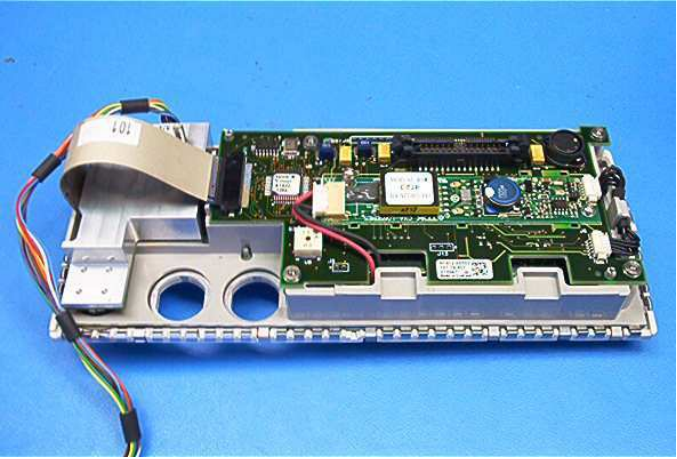
Instructions	Visual
<p>Step 10:</p> <ul style="list-style-type: none">• Fit the split washer to the calibrator assembly <p>Step 11:</p> <ul style="list-style-type: none">• Attach the display to the display interface board using the 4 screws removed earlier	
<p>Step 12:</p> <ul style="list-style-type: none">• Connect the white plastic plug to the display interface board	

Instructions	Visual
<p>Step 13:</p> <ul style="list-style-type: none"> • Attach the front panel sub-frame to the display support moulding, ensuring that all plastic clips are engaged to hold it securely <p>Step 14:</p> <ul style="list-style-type: none"> • Connect the flex cable to the display interface board, and then tighten the locking tab 	
<p>Step 15:</p> <ul style="list-style-type: none"> • Re-fit the calibrator plug 	

Additional Repair Notes

Replacing A Sensor Flex Assembly:

- The Sensor flex assembly is supplied straight
- Create A sharp bend (Figure 6-19): The flex circuit must be bent at a right-angle where it meets the printed circuit board. It can only be bent after heat has been applied to it (i. e. using a hot-air gun, or a similar device)

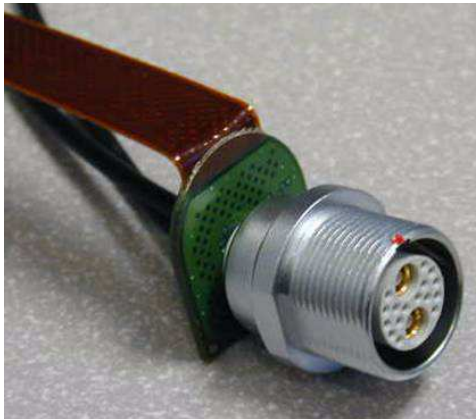

Figure 6-19 Creating a sharp bend

NOTE

- Once this sharp bend has been created, the flex should not be bent at this point again; to do so may break the tracking within the flex.
- Route and connect the sensor flex assembly: once the sensor flex assembly has been attached to the power meter; it should be folded to match the route taken by the assembly being replaced. Heat may be used to assist the folding of the flex.

Main Board vs. Rear Panel Assembly

Instructions	Visual
<ul style="list-style-type: none"> • Due to a difference in the connector positions for main board revision 102 and revision 103, there are TWO different rear panels • Revision 102 main boards are not available as spares – all spare main boards will be revision 103 (or newer) • When replacing a revision 102 main board, take note that the rear panel will need to be replaced • Figure 6-20 and Figure 6-21 show where to find the main board revision markings 	<div data-bbox="658 395 1208 812" data-label="Image"> <p>Main Board Revision 102</p> </div> <p data-bbox="594 852 715 881">Figure 6-20</p> <div data-bbox="658 923 1208 1331" data-label="Image"> <p>Main Board-Revision 103</p> </div> <p data-bbox="594 1364 715 1394">Figure 6-21</p>

Replacing the PPMC Assembly

- The PPMC assembly is pre-programmed with N1912A firmware
- Always perform a firmware upgrade to the instrument if the PPMC assembly has been replaced

NOTE

- Fitting a PPMC assembly that has been pre-programmed with N1912A firmware to an N1911A power meter will generate errors; these errors will disappear once the firmware upgrade procedure has been carried out.

-
- Instrument serial number:

This can be stored in the PPMC assembly via the command:

```
SERV: SNUM <CHARACTER DATA>
```

- Instrument option(s):

This/these can be stored in the PPMC assembly via the command:

```
SERV: OPT "< CHARACTER DATA>"
```

Refer to the *Programming Guide* for further details on the use of these commands.

Replacing the Calibrator Semi-Rigid/Split Ferrite

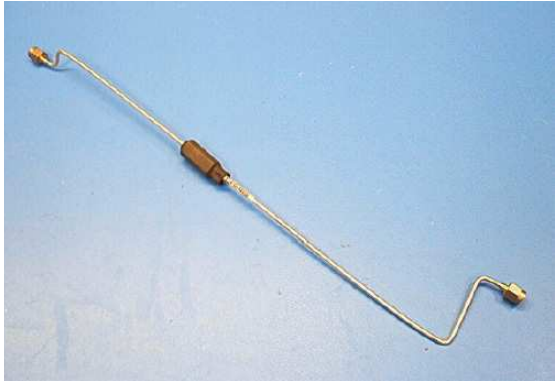
Instructions	Visual
<ul style="list-style-type: none"> • Separate the two halves of the ferrite (Figure 6-22) • Position the ferrite such that it's furthest edge is 120 mm (4 ¾") from the bend of the semi-rigid (Figure 6-23) • Hold the ferrite in place by applying a coating of silicone or silicone-rubber compound (e. g. RTV) along that 20 mm (¾") section of the semi-rigid • Join both halves of the ferrite, keeping the mating surfaces free of the silicone compound if possible 	<div style="text-align: center;">  <p>Figure 6-22 shows a semi-rigid cable with a split ferrite core. The ferrite is split into two halves, and a small ferrite component is visible above the cable. The cable has two connectors at the ends.</p> </div> <div style="text-align: center; margin-top: 20px;">  <p>Figure 6-23 shows the semi-rigid cable with the ferrite core installed. The ferrite is a small, cylindrical component mounted on the cable. The cable has two connectors at the ends.</p> </div>



7 Contacting Agilent Technologies

Introduction	112
Before Calling Agilent Technologies	113
Check the Basics	114
Instrument Serial Numbers	115
Agilent Sales and Service Offices	116
Returning Your Power Meter for Service	117
Useful Web Pages	118

This chapter details what to do if you have a problem with your power meter.



Introduction

Contacting Agilent Technologies

This section details what to do if you have a problem with your power meter. If you have a problem with your power meter, first refer to the page titled [“Before Calling Agilent Technologies”](#). This section contains a checklist that helps identify some of the most common problems. If you wish to contact Agilent Technologies about any aspect of the power meter, from service problems to ordering information, refer to the page titled [“Agilent Sales and Service Offices”](#). If you wish to return the power meter to Agilent Technologies, refer to the section titled [“Returning Your Power Meter for Service”](#).

Before Calling Agilent Technologies

Before calling Agilent Technologies or returning the power meter for service, please make the checks listed in [“Check the Basics”](#) on page 114. If your power meter is covered by a separate maintenance agreement, please be familiar with the terms.

Agilent Technologies offers several maintenance plans to service your power meter after warranty expiration. Call your Agilent Technologies Sales and Service Center for full details.

If the power meter becomes faulty and you wish to return the faulty instrument, follow the description on how to return the faulty instrument in [“Returning Your Power Meter for Service”](#) on page 117.

Check the Basics

Problems can be solved by repeating what was being performed when the problem occurred. A few minutes spent in performing these simple checks may eliminate time spent waiting for instrument repair. Before calling Agilent Technologies or returning the power meter for service, please make the following checks:

- Check that the line socket has power.
- Check that the power meter is plugged into the proper ac power source.
- Check that the power meter is switched on.
- Check that the line fuse is in working condition.
- Check that the other equipment, cables, and connectors are connected properly and operating correctly.
- Check the equipment settings in the procedure that was being used when the problem occurred.
- Check that the test being performed and the expected results are within the specifications and capabilities of the power meter.
- Check the power meter display for error message.
- Check operation by performing the self tests.
- Check with a different power sensor.

Instrument Serial Numbers

Agilent Technologies makes frequent improvements to its products to enhance their performance, usability and reliability. Agilent Technologies service personnel have access to complete records of design changes for each instrument. The information is based on the serial number and option designation of each power meter.

Whenever you contact Agilent Technologies about your power meter have a complete serial number available. This ensures you obtain the most complete and accurate service information. The serial number can be obtained by:

- Querying the power meter over a remote interface (via the *IDN? Command).
- From the front panel (via the Service menu).
- From the serial number label.

The serial number label is attached to the rear of each Agilent Technologies instrument. This label has two instrument identification entries. The first provides the instruments serial number and the second provides the identification number for each option built into the instrument.

The serial number is divided into two parts: the prefix (two letters and the first four numbers), and the suffix (the last four numbers).

The prefix letters indicate the country of manufacture. This code is based on the ISO international country code standard, and is used to designate the specific country of manufacture for the individual product. The same product number could be manufactured in two different countries. In this case the individual product serial numbers would reflect different country of manufacture codes. The prefix also consists of four numbers. This is a code identifying the date of the last major design change.

The suffix indicates an alpha numeric code which is used to ensure unique identification of each product throughout Agilent Technologies.

Agilent Sales and Service Offices

In any correspondence or telephone conversations, please refer to the power meter by its model number and full serial number. With this information, the Agilent representative can quickly determine whether your unit is still within its warranty period.

UNITED STATES	Agilent Technologies (tel) 1 800 829 4444
CANADA	Agilent Technologies Canada Inc., Test & Measurement (tel) 1 877 894 4414
EUROPE	Agilent Technologies, Test & Measurement, European Marketing Organization (tel) (31 20) 547 2000
JAPAN	Agilent Technologies Japan Ltd. (tel) (81) 426 56 7832 (fax) (81) 426 56 7840
LATIN AMERICA	Agilent Technologies, Latin America Region Headquarters, USA (tel) (305) 267 4245 (fax) (305) 267 4286
AUSTRALIA and NEW ZEALAND	Agilent Technologies Australia Pty Ltd. (tel) 1-800 629 4852 (Australia) (fax) (61 3) 9272 0749 (Australia) (tel) 0-800 738 378 (New Zealand) (fax) (64 4) 802 6881 (New Zealand)
ASIA PACIFIC	Agilent Technologies, Hong Kong (tel) (852) 3197 7777
You can visit our website:	www.agilent.com/find/assist

Returning Your Power Meter for Service

Use the information in this section if you need to return your power meter to Agilent Technologies.

Packaging the power meter for shipment to Agilent Technologies for service

- Fill in a blue service tag (available at the end of most hardcopy *Agilent Service Guides*) and attach it to the power meter. Please be as specific as possible about the nature of the problem. Send a copy of any or all of the following information:
 - Any error messages that appeared on the power meter display.
 - Any information on the performance of the power meter.

CAUTION

Power meter damage can result from using packaging materials other than those specified. Never use styrene pellets in any shape as packaging materials. They do not adequately cushion the power meter or prevent it from shifting in the carton. Styrene pellets cause power meter damage by generating static electricity and by lodging in the rear panel.

-
- Use the original packaging materials or a strong shipping container that is made of double-walled, corrugated cardboard with 159 kg (350 lb) bursting strength. The carton must be both large enough and strong enough to accommodate the power meter and allow at least 3 to 4 inches on all sides of the power meter for packing material.
 - Surround the power meter with at least 3 to 4 inches of packing material, or enough to prevent the power meter from moving in the carton. If packing foam is not available, the best alternative is SD- 240 Air Cap™ from Sealed Air Corporation (Commerce, CA 90001). Air Cap looks like a plastic sheet covered with 1-1/4 inch air filled bubbles. Use the pink Air Cap to reduce static electricity. Wrap the power meter several times in the material to both protect the power meter and prevent it from moving in the carton.
 - Seal the shipping container securely with strong nylon adhesive tape.
 - Mark the shipping container “FRAGILE, HANDLE WITH CARE” to ensure careful handling.
 - Retain copies of all shipping papers.

Useful Web Pages

- Main Product Page
www.agilent.com/find/wideband_powermeters
- Product Manuals
www.agilent.com/find/pseriesmanuals
- Product Firmware
www.agilent.com/find/pseriesfirmware
- Performance Test & Calibration Software
www.calsw.tm.agilent.com
- Service Notes
www.literature.agilent.com/LitWeb/Admin/SNSelectForTM.cfm

www.agilent.com

Contact us

To obtain service, warranty or technical support assistance, contact us at the following phone numbers:

United States:

(tel) 800 829 4444 (fax) 800 829 4433

Canada:

(tel) 877 894 4414 (fax) 800 746 4866

China:

(tel) 800 810 0189 (fax) 800 820 2816

Europe:

(tel) 31 20 547 2111

Japan:

(tel) (81) 426 56 7832 (fax) (81) 426 56 7840

Korea:

(tel) (080) 769 0800 (fax) (080) 769 0900

Latin America:

(tel) (305) 269 7500

Taiwan:

(tel) 0800 047 866 (fax) 0800 286 331

Other Asia Pacific Countries:

(tel) (65) 6375 8100 (fax) (65) 6755 0042

Or visit Agilent worldwide Web at:

www.agilent.com/find/assist

Product specifications and descriptions in this document are subject to change without notice. Always refer to Agilent Web site for the latest revision.

© Agilent Technologies, Inc. 2006 - 2011

Printed in Malaysia
Sixth Edition, March 9, 2011

N1912-90015



Agilent Technologies