



Agilent Technologies LogicWave E9340A PC-Hosted Logic Analyzer

Technical Data



Figure 1. Agilent's New PC-Hosted Logic Analyzer Offers Intuitive and Transportable Measurement Capability.

Affordable and User-friendly Logic Analysis

The Agilent Technologies LogicWave E9340A logic analyzer offers design engineers a low-cost, transportable debug tool that is easy to set up and use. With the amazing price/performance of LogicWave, designers can afford to use a personal analyzer to conduct basic measurements rather than wait for the lab analyzer to become available.

LogicWave is PC-hosted, making it an ideal tool for cramped workspaces. The intuitive, single window user interface runs as a Microsoft® Windows 95/98/NT application on any Pentium® or better PC and does not require a dedicated PC. Run it on a laptop and the entire system is completely portable.

Software and software updates are available at no cost on the Internet. Download the user interface now and try it yourself at: www.agilent.com/find/LogicWave or request the LogicWave product CD number 5968-6655E.

Model	Agilent Technologies LogicWave (E9340A)
State/timing channels	34
Maximum state clock	100 MHz
Maximum timing sample-rate	250 MHz
Memory depth	128K timing, 64K state
User interface	Windows 95, 98, 2000 (Professional and Me), NT 3.1, and NT 4.1, PC-hosted (runs as an application on any Pentium or better, desktop or laptop)
"WYDIWYC" timing trigger	"What you draw is what you capture" visual timing trigger events
Printers	Shared with the host PC - can print to any local or network printer supported by the PC
Probing	Agilent patented, 100kΩ, 1.5 pF
Dimensions	11.5" x 9" x 2.5" (29.1 x 22.8 x 6.3 cm)
Weight	4.5 pounds (2.1 kg)
I/O ports	Enhanced parallel connection to PC for fast display update rates, trigger IN/OUT BNC

Microsoft is a U.S. registered trademark of Microsoft Corp.
Pentium is a U.S. registered trademark of Intel Corporation.



Agilent Technologies
Innovating the HP Way

Agilent Technologies Logic Wave E9340A

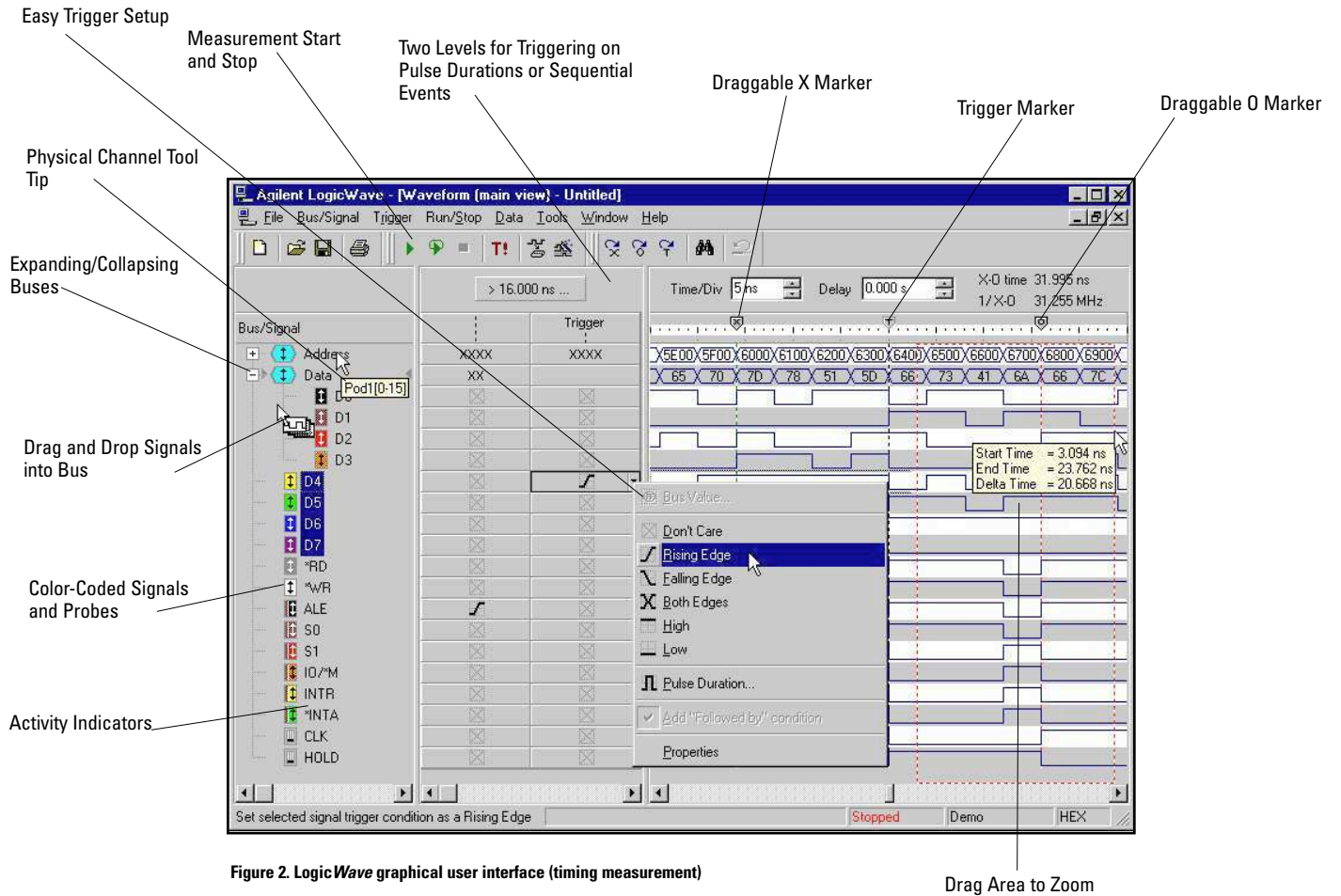

Figure 2. Logic Wave graphical user interface (timing measurement)

Agilent Technologies LogicWave E9340A

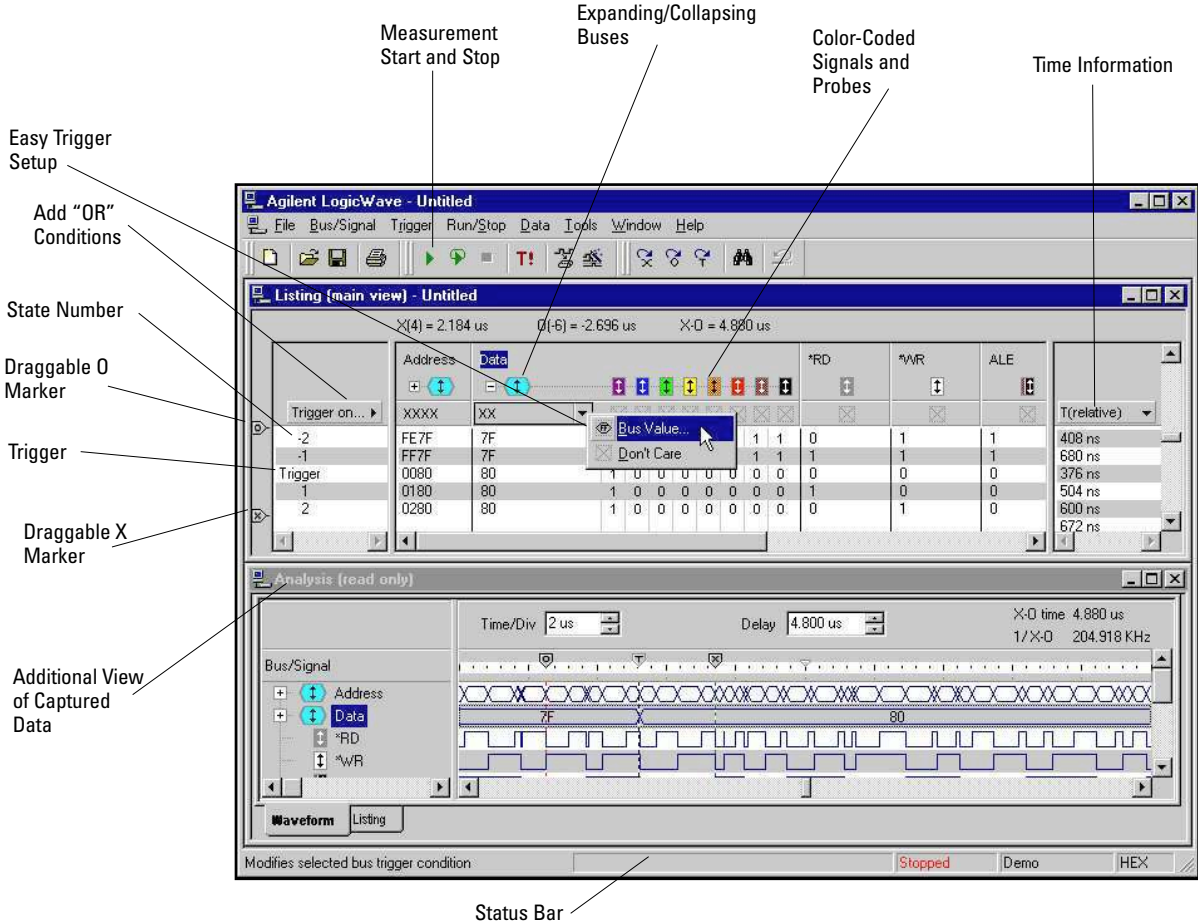

Figure 3. LogicWave graphical user interface (state measurement)

Agilent Technologies LogicWave E9340A

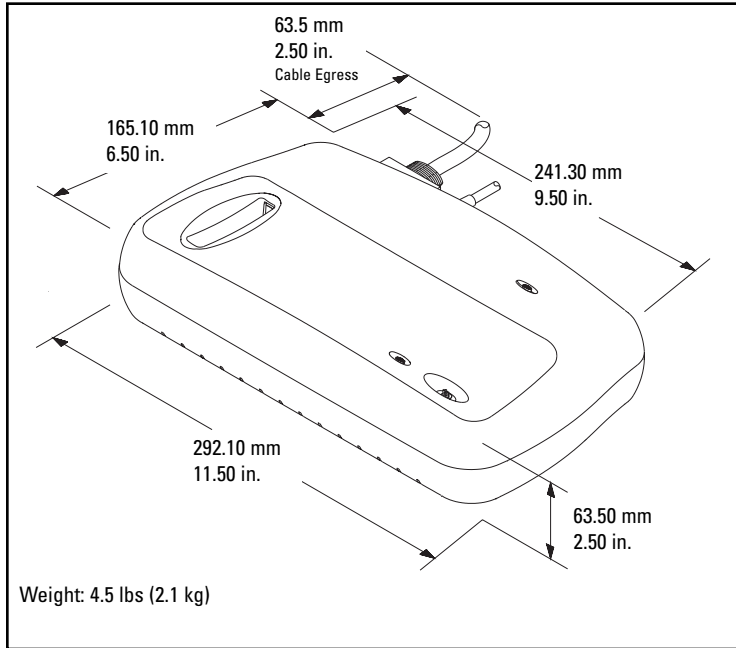

Figure 4. LogicWave dimensions and weight

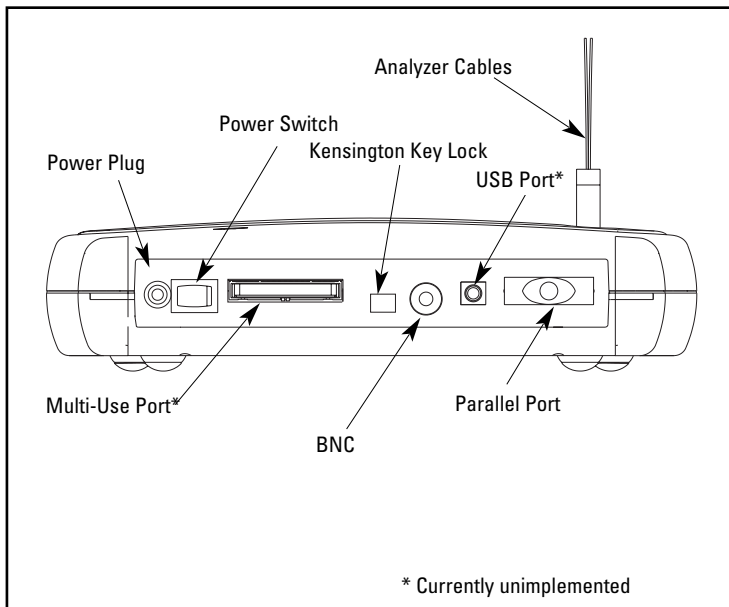

Figure 5. Diagram of LogicWave rear panel

Additional Features:

- **Zoom box** — To zoom in on part of a waveform, click and drag a box around the area of interest.
- **Multiple group into bus** — In addition to dragging-and-dropping individual channels into a bus, you can also select multiple channels. Use Ctrl+mouse, right click, and select "Group into bus" from the menu.
- **Physical channel tool tip** — After renaming signals, you can hold the cursor over the new name and the location (pod and channel numbers) of the signal will appear.
- **Color-coded signals and probe leads** — Colored activity indicators on screen correspond to the color of the equivalent channel on the general-purpose lead set.
- **External trigger for scope** — LogicWave can be used to trigger an oscilloscope by connecting the PortOut BNC to the PortIn of the oscilloscope.
- **Capture screen shot** — Use Ctrl+Alt+PrintScrn to capture a LogicWave screen, as you would with any other Windows program.
- **Export data to Microsoft Excel** — an ASCII version of LogicWave files can be imported into Excel for data analysis.
- **Off-line analysis** — Data files can be viewed on any machine that has the software interface installed, regardless of whether a logic analyzer is connected or not.

Agilent Technologies LogicWave E9340A

Specifications and Characteristics

Timing Analysis

Sample period accuracy	±0.01%
Channel-to-channel skew	2 ns typical, 3 ns max
Timing interval accuracy	±(sample period accuracy + channel-to-channel skew + 0.01% of time interval reading)

State Analysis

Setup/hold¹	4.0/0 ns fixed
Minimum state clock pulse width	3.5 ns
Time tag resolution	8 ns or ± 0.1% (whichever is greater)
Maximum time count between states	34 seconds
Clock qualifiers setup/hold	4.0/0 ns fixed

Triggering

Sequencer speed	125 MHz maximum
State sequence levels	3
Timing sequence levels	2
Port In delay	35 ns between rising edge on Port In BNC and don't care logic analyzer trigger
Port Out delay	120 ns between logic analyzer trigger and rising edge on Port Out BNC

Probes

Input resistance	100 kΩ±2%
Parasitic tip capacitance	1.5 pF
Minimum input voltage swing	500 mV peak-to-peak
Threshold accuracy	±(100 mV + 3% of threshold setting)
Threshold range	TTL, ECL, -6.0 V to + 6.0 V in 50 mV increments
Maximum input voltage	± 40 V peak

Operating Environment

Temperature	Instrument: 0°C to 55° C (+32°F to 131°F) Disk media: 10°C to 40°C (+50°F to 104°F)
Humidity	Up to 95% relative humidity at 40°C
Altitude	4,572 m (15,000 ft)

Data Storage

Supported file formats for screen shots

Use CTRL + ALT + PrtScrn to create bitmap

Configuration and data files	Encoded in binary format (stored to or loaded from host PC); can export acquired data to an ASCII formatted file.
-------------------------------------	---

¹ Minimum setup/hold time specified for single-clock, single-edge acquisition. For single-clock, multi-edge or multi-clock, multi-edge acquisition, add 1.0 ns to setup time.

Probing Alternatives

Probing the device under test is potentially one of the most difficult and certainly one of the most important tasks in debugging a digital design. That is why Agilent Technologies provides a wider variety of probing solutions than anyone else in the industry — each with a different set of advantages particular to a given situation. We like to think of it as helping you get your signals off to a great start.

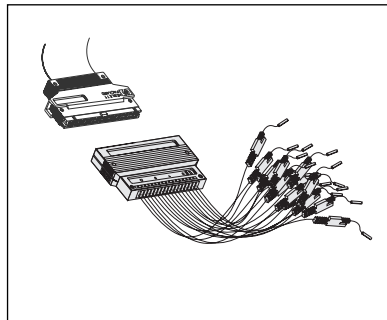

Figure 6. General-purpose lead set

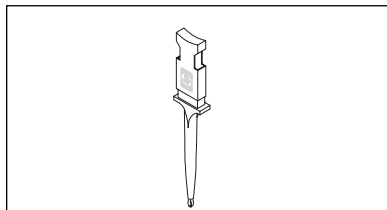

Figure 7. Surface mount IC clip

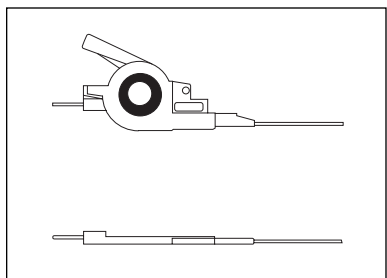

Figure 8. Ultra-Fine pitch surface mount device clips

Probing Alternative	Advantages	Limitation
General-Purpose Lead Sets and Surface Mount IC Clips (Figure 6 & 7)	Most flexible method. Works in conjunction with SMD clips and Wedge adapters listed below. Included with logic analyzer purchase.	Can be cumbersome when connecting a large number of channels.
Ultra-Fine Pitch Surface Mount Device Clips (Figure 8)	Smallest IC clips in the industry to date (down to 0.5 mm). Works with both logic analyzer and scope probing systems.	Same as above plus small incremental cost.
Wedge Probe Adapter for QFP Packages (Figure 9)	Compressible dual conductors between adjacent IC legs make 3-16 adjacent signal leads available to logic analyzer and scope probing systems.	Same as above plus small incremental cost.
Direct Connection to Device Under Test via Built-In Connectors (Figure 10 & 11)	Very reliable and convenient probing system when frequent probing connections are required (manufacturing or field test for example). Connectors can be located at optimal position in the device under test.	Requires advance planning to integrate into design process. Moderate (normal density) to significant (high density) incremental cost.

Replacement Part Numbers for Logic Analyzer Probes

5959-9333	Five gray probe leads
5959-9334	Five short ground leads
01650-61608	16-Channel probe lead set
5090-4356	Surface-mount IC clips (package of 20)
5959-0288	Throughhole IC clips (package of 20)

Probing Alternatives for Logic Analyzers

10467-68701	0.5 mm SMD clips (Qty 4)
E2613A	Wedge, 0.5mm, 3 signal (Qty1)
E2613B	Wedge, 0.5mm, 3 signal (Qty 2)
E2614A	Wedge, 0.5mm, 8 signal (Qty 1)
E2643A	Wedge, 0.5mm, 16 signal (Qty 1)
E2615A	Wedge, 0.65mm, 3 signal (Qty1)
E2615B	Wedge, 0.65mm, 3 signal (Qty 2)
E2616A	Wedge, 0.65mm, 8 signal (Qty 1)
E2644A	Wedge, 0.65mm, 16 signal (Qty 1)
E5346A	High-Density Termination Adapter
E5346-44701	Shroud for High-Density Termination Adapter
E5346-68701	Mictor High-Density Connector (Qty 5)
01650-63203	Normal-Density Termination Adapter
1251-8106	Normal-Density 20-pin Connector

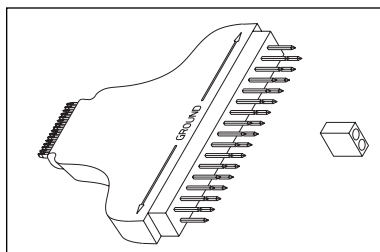

Figure 9. Wedge probe adapters for QFP package

The LogicWave probe cables are compatible with a wide range of probing adapters and accessories available from Agilent Technologies and its channel partners. See *Probing Solutions for Agilent Technologies Logic Analysis Systems* (pub. no. 5968-4632E) for more information on probing.

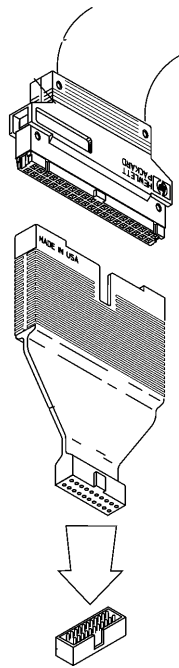

Figure 10. Normal-density direct connection solution

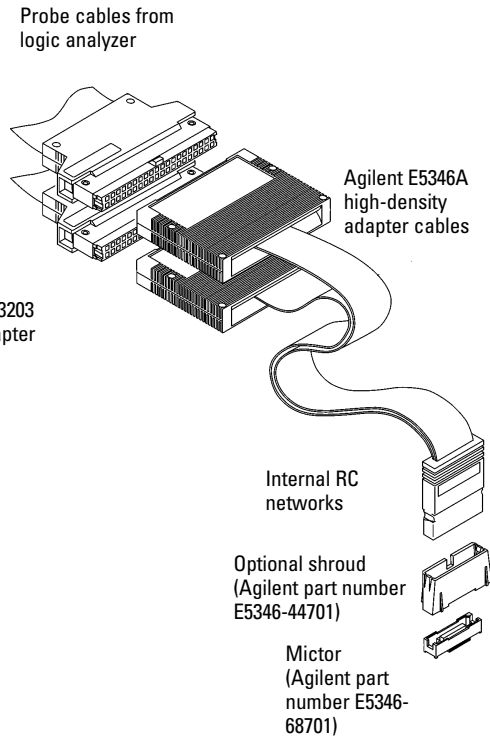

Figure 11. High-density direct connection solution

Related Literature

Title	Publication Description	Publication Number
<i>LogicWave User Interface Software</i>	Product CD-ROM	5968-6655E
<i>Probing Solutions for Agilent Technologies Logic Analysis Systems</i>	Product Overview	5968-4632E

Product Warranty

LogicWave is warranted against defects in materials and workmanship for a period of three years from date of shipment. Some newly manufactured Agilent Technologies products may contain remanufactured parts, which are equivalent to new in performance. If you send notice of defects during the warranty period, Agilent will either repair or replace hardware products that prove defective.

Ordering Information

E9340A	LogicWave 34-Channel, PC-Hosted Logic Analyzer
Option 001	Quick Reference Card and Target Board

Agilent Technologies' Test and Measurement Support, Services, and Assistance

Agilent Technologies aims to maximize the value you receive, while minimizing your risk and problems. We strive to ensure that you get the test and measurement capabilities you paid for and obtain the support you need. Our extensive support resources and services can help you choose the right Agilent products for your applications and apply them successfully. Every instrument and system we sell has a global warranty. Support is available for at least five years beyond the production life of the product. Two concepts underlie Agilent's overall support policy: "Our Promise" and "Your Advantage."

Our Promise

Our Promise means your Agilent test and measurement equipment will meet its advertised performance and functionality. When you are choosing new equipment, we will help you with product information, including realistic performance specifications and practical recommendations from experienced test engineers. When you use Agilent equipment, we can verify that it works properly, help with product operation, and provide basic measurement assistance for the use of specified capabilities, at no extra cost upon request. Many self-help tools are available.

Your Advantage

Your Advantage means that Agilent offers a wide range of additional expert test and measurement services, which you can purchase according to your unique technical and business needs. Solve problems efficiently and gain a competitive edge by contracting with us for calibration, extra-cost upgrades, out-of-warranty repairs, and on-site education and training, as well as design, system integration, project management, and other professional engineering services. Experienced Agilent engineers and technicians worldwide can help you maximize your productivity, optimize the return on investment of your Agilent instruments and systems, and obtain dependable measurement accuracy for the life of those products.

For more assistance with your test & measurement needs go to:

www.agilent.com/find/assist

Or contact the test and measurement experts at Agilent Technologies (During normal business hours)

United States:

(tel) 1 800 452 4844

Canada:

(tel) 1 877 894 4414
(fax) (905) 206 4120

Europe:

(tel) (31 20) 547 2000

Japan:

(tel) (81) 426 56 7832
(fax) (81) 426 56 7840

Latin America:

(tel) (305) 267 4245
(fax) (305) 267 4286

Australia:

(tel) 1 800 629 485
(fax) (61 3) 9272 0749

New Zealand:

(tel) 0 800 738 378
(fax) 64 4 495 8950

Asia Pacific:

(tel) (852) 3197 7777
(fax) (852) 2506 9284

Product specifications and descriptions in this document subject to change without notice.

Copyright© 2000 Agilent Technologies
Printed in USA 11-00

5968-5560E



Agilent Technologies
Innovating the HP Way