

Errata

Title & Document Type: E1430A VXI ADC User's Guide

Manual Part Number: E1430-90011

Revision Date: June 1,1995

HP References in this Manual

This manual may contain references to HP or Hewlett-Packard. Please note that Hewlett-Packard's former test and measurement, semiconductor products and chemical analysis businesses are now part of Agilent Technologies. We have made no changes to this manual copy. The HP XXXX referred to in this document is now the Agilent XXXX. For example, model number HP8648A is now model number Agilent 8648A.

About this Manual

We've added this manual to the Agilent website in an effort to help you support your product. This manual provides the best information we could find. It may be incomplete or contain dated information, and the scan quality may not be ideal. If we find a better copy in the future, we will add it to the Agilent website.

Support for Your Product

Agilent no longer sells or supports this product. You will find any other available product information on the Agilent Test & Measurement website:

www.tm.agilent.com

Search for the model number of this product, and the resulting product page will guide you to any available information. Our service centers may be able to perform calibration if no repair parts are needed, but no other support from Agilent is available.





HP E1430 VXI ADC

User's Guide

Part Number E1430-90011
Microfiche Number E1430-90211

Printed in U.S.A.
Print Date: June, 1995

©Hewlett-Packard Company, 1992, 1993, 1994, 1995. All rights reserved.
8600 Soper Hill Road Everett, Washington 98205-1298 U.S.A.

NOTICE

The information contained in this document is subject to change without notice.

HEWLETT-PACKARD MAKES NO WARRANTY OF ANY KIND WITH REGARD TO THIS MANUAL, INCLUDING, BUT NOT LIMITED TO, THE IMPLIED WARRANTIES OF MERCHANTABILITY AND FITNESS FOR A PARTICULAR PURPOSE. Hewlett-Packard shall not be liable for errors contained herein or direct, indirect, special, incidental or consequential damages in connection with the furnishing, performance, or use of this material.

WARRANTY

A copy of the specific warranty terms applicable to your Hewlett-Packard product and replacement parts can be obtained from your local Sales and Service Office.

This document contains proprietary information which is protected by copyright. All rights are reserved. No part of this document may be photocopied, reproduced or translated to another language without the prior written consent of Hewlett-Packard Company. This information contained in this document is subject to change without notice.

Use of this manual and flexible disk(s) or tape cartridge(s) supplied for this pack is restricted to this product only. Additional copies of the programs can be made for security and back-up purposes only.

- © Copyright 1983, 1984, 1985, 1986, 1987, 1988 Hewlett-Packard Company.
- © Copyright 1979 The Regents of the University of Colorado, a body corporate.
- © Copyright 1979, 1980, 1983 The Regents of the University of California.
- © Copyright 1980, 1984 AT&T Technologies. All Rights Reserved.
- © Copyright 1986, 1987 Sun Microsystems, Inc.
- © Copyright 1984, 1985 Productivity Products Intl.

RESTRICTED RIGHTS LEGEND

Use, duplication, or disclosure by the government is subject to restrictions as set forth in subdivision (c) (1) (ii) of the Rights in Technical Data and Computer Software clause at DFARS 252.227-7013.

HEWLETT-PACKARD COMPANY
3000 Hanover St.
Palo Alto, CA 94303

Rights for non-DOD U.S. Government Departments and Agencies are set forth in FAR 52.227-19 (c) (1,2)

Copyright (c) 1994 Hewlett-Packard Company. All rights Reserved

The HP E1430A at a Glance

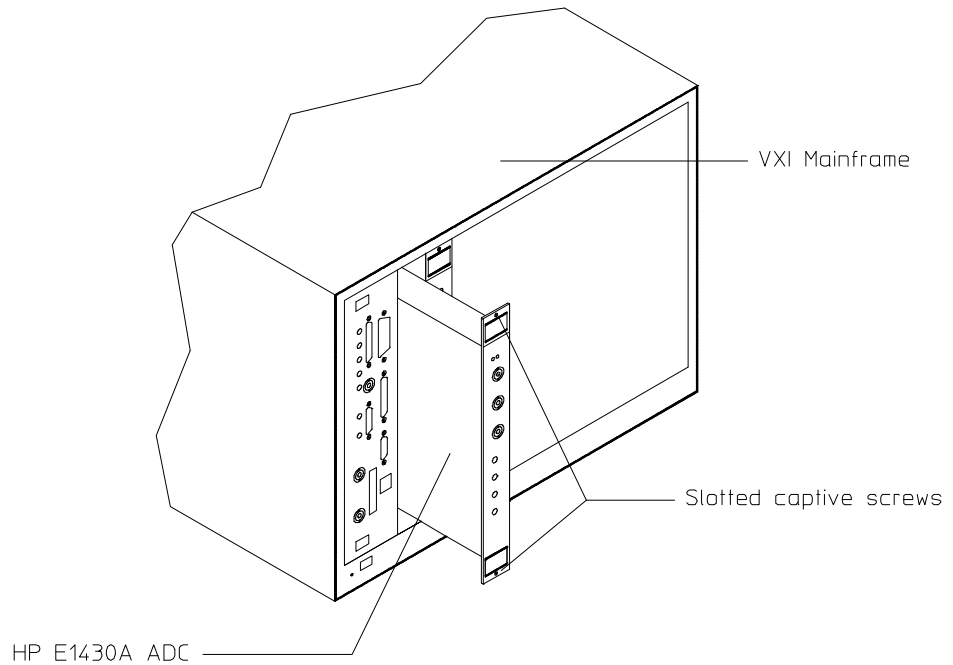

Number of Channels	1
Type of Input	50 ohm
Input Bandwidths (alias protected)	0 Hz to 4 MHz
Sample Rate	10 MHz
Voltage Ranges	7.8 mV to 8 V_{peak}
Raw ADC resolution	23 bits
VXI Bus Support	VME and Local Bus
VXI Device Type	Register-based
Size	C-sized, single slot

Options and Accessories

Options

Opt AYD, a 10.24 MHz AYD clock, is the only option available for this module. It is an upgrade for the main PC assembly.

The following items are included with your HP E1430A:

Hardware:

- HP E1430A Input - C-size VXI module
- Software media:
 - DAT tape
 - 3 1/2" disks

Software:

DAT Tape

- The HP E1430A C Interface Library; including source files, HP-UX Series 300 C Library binaries and HP-UX Series 700 C Library binaries
- HP E1485A/B C Library binaries
- C-SCPI libraries for the HP E1430A (HP-UX Series 300 and HP-UX Series 700)
- SCPI downloadable for the HP E1405/06 Command module
- Example programs

Programming Software Disk

- The HP E1430A C Interface Library source files
- Example programs

SCPI Driver for Command Module Disk

- SCPI downloadable for the HP E1405/06 Command Module
- DOS downloader for HP E1405/06 Command Module

Documentation:

- HP E1430A User's Guide
- Online manual pages accessed via ptman (HP-UX only)

In This Book

This guide provides instructions for installing, verifying the performance, adjusting, and troubleshooting the HP E1430A VXI ADC module. C Library software support reference material and SCPI command reference materials are also provided.

Associated with this product is the HP E1485A/B and the HP 35635T Programmer's Toolkit. The HP E1485 A/B is a VXI signal processing module. The 35635T Programmer's Toolkit consists of libraries and tools that form an application program development environment.

Chapter 1, "Installing the HP E1430A," provides step-by-step instructions for installation and for setting the address of the HP E1430A. Included in this chapter are basic instructions for installing the C-library interface, the compiled SCPI driver, and the downloadable SCPI driver.

Chapter 2, "Verifying Specifications," lists the specifications for the HP E1430A and the specifications for the recommended test equipment. This chapter also provides step-by-step instructions for installing and running the performance test software used to verify the specifications.

Chapter 3, "Troubleshooting the HP E1430A," provides two methods available for localizing problems with the HP E1430A module. The first method uses HP-IB commands. The second method, which requires added test equipment, provides instructions for troubleshooting using the performance tests.

Chapter 4, "Adjusting the HP E1430A," contains the adjustment procedures for the HP E1430A. These adjustments are used to return the module to specified operating accuracy if the performance tests indicate a specification failure.

Chapter 5, "Replaceable Parts," provides ordering information and identification of all replaceable parts. This chapter also contains illustrations that show how to disassemble the HP E1430A module in order to replace the front panel.

Chapter 6, "Backdating," contains information necessary to modify this guide for modules that differ from those currently being produced.

Chapter 7, "Circuit Descriptions," provides a basic understanding of the major circuits within the HP E1430A.

Chapter 8, "Using the HP E1430A" includes a front panel description and an explanation of the VXI backplane connections.

Chapter 9, "Programming the HP E1430A with the C Interface Libraries" contains programming information and a quick reference to the C-libraries, by category and alphabetically.

Chapter 10, “C Interface Library Support Reference” lists and describes all the C-library commands. At the end of the chapter is a list and description of the error messages.

Chapter 11, “SCPI Overview and Commands,” provides a brief introduction to SCPI and describes all of the IEEE 488.2 common commands implemented by the HP E1430A. A sample program using SCPI commands is at the end of this chapter.

Chapter 12, “VXI Registers,” describes each register and its function in the HP E1430A module.

Table of Contents

1 Installing the HP E1430A

- Installing the HP E1430A 1-2
- To inspect the HP E1430A 1-2
- To install the HP E1430A 1-3
- To install the C library interface 1-6
- To install the compiled SCPI (C-SCPI) driver 1-7
- To install the downloadable SCPI driver 1-8
- To store the module 1-10
- To transport the module 1-10

2 Verifying Specifications

- To verify specifications 2-2
- To start pt1430 in the HP-UX environment 2-5
- To start pt1430 in the DOS environment 2-6
- To run the tests 2-7
- Specifications 2-9

3 Troubleshooting the HP E1430A

- To troubleshoot using HP-IB interface 3-2
- To troubleshoot using performance tests 3-5

4 Adjusting the HP E1430A

- To adjust the module 4-2

5 Replaceable Parts

- Replaceable Parts 5-2
- To remove the front panel 5-6

6 Backdating

- Backdating 6-2

7 Circuit Descriptions

- Block Diagram and Description 7-2

8 Using the HP E1430A

Front-panel Description 8-2

VXI Backplane Connections 8-4

9 Programming the HP E1430A with the C Interface Libraries

Getting Started 9-3

C Libraries Quick Reference (by Category) 9-7

C Libraries Quick Reference (Alphabetical) 9-12

10 C Interface Library Support Reference

Errors 10-81

11 SCPI Overview and Commands

Introduction to SCPI 11-2

SCPI Commands 11-4

Command Syntax 11-4

The Status Registers 11-7

The Service Request Process 11-10

The HP E1430A Register Sets 11-12

SCPI Common Commands 11-18

Other SCPI Commands 11-31

Example Program Using SCPI Commands 11-77

SCPI Commands to control and sync up two HP E1430A's 11-79

12 VXI Registers

The Control Registers 12-2

Index

Declaration of Conformity

Need Assistance?

About this Edition

1

Installing the HP E1430A

Installing the HP E1430A

This chapter contains instructions for installing the HP E1430A VXI ADC Module and its drivers. This chapter also includes instructions for transporting and storing the module.

To inspect the HP E1430A

The HP E1430A single channel VXI ADC Module was carefully inspected both mechanically and electrically before shipment. It should be free of marks or scratches and it should meet its published specifications upon receipt.

If the module was damaged in transit, do the following:

- Save all packing materials.
- File a claim with the carrier.
- Call your Hewlett-Packard sales and service office.

To install the HP E1430A

If you will be using the HP E1406A Command Module and an external computer with DOS based windows, use the HP VXI Installation Consultant (HP VIC) to install the HP E1430A module. Before starting HP VIC, insert the "SCPI Driver for Command Module" disk into your computer. HP VIC steps you through the installation procedure then tests the modules using the *tst? command. HP VIC may time out before the test is finished and display a "timed out" message. If this occurs, exit HP VIC and send the *tst? command. For instructions on sending the *tst? command, see chapter 3, "Troubleshooting the HP E1430A."

Caution

To protect circuits from static discharge, observe anti-static techniques whenever handling the HP E1430A VXI ADC Module.

- 1** Set up your VXI mainframe. See the installation guide for your mainframe.
- 2** Select a slot in the VXI mainframe for the HP E1430A module.
The HP E1430A module's local bus receives ECL-level data from the module immediately to its left and outputs ECL-level data to the module immediately to its right. Every module using the local bus is keyed to prevent two modules from fitting next to each other unless they are compatible. If you will be using the local bus, select adjacent slots immediately to the left of the data-receiving module. If the VXI Bus is used, maximum data rates will be reduced but the module can be placed in any available slot.
- 3** Using a small screwdriver or similar tool, set the logical address configuration switch on the HP E1430A.
Each module in the system must have a unique logical address. The factory default setting is 1000 0001 (129). If an HP E1485 Signal Processor module will be controlling the HP E1430A module, select an address within the HP E1485 module's servant area. If an HP-IB command module will be controlling the HP E1430A module, select an address that is a multiple of 8.

HP E1430A User's Guide
To install the HP E1430A

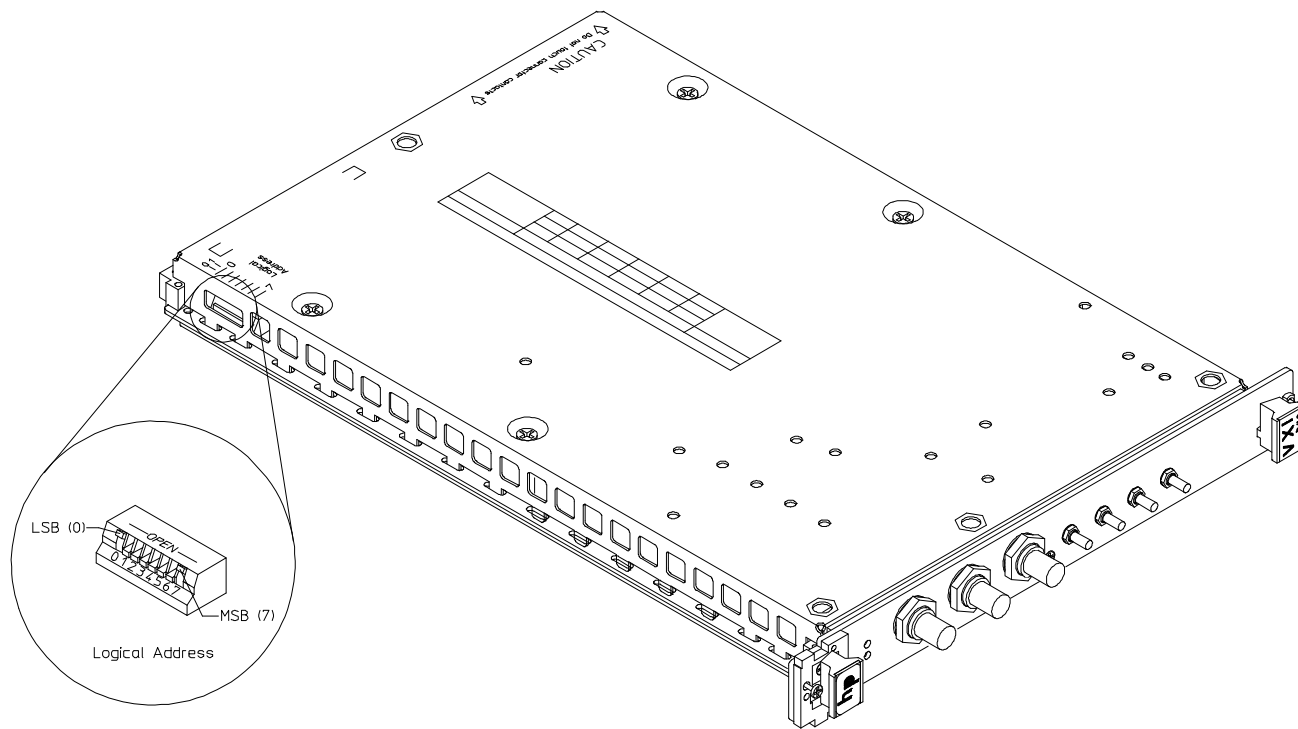

- 4** Set the mainframe's power switch to off (**O**).
- 5** Place the module's card edges (top and bottom) into the module guides in the slot.
- 6** Slide the module into the mainframe until the module connects firmly with the backplane connectors. Make sure the module slides in straight.
- 7** Attach the module's front panel to the mainframe chassis using the module's captive mounting screws.

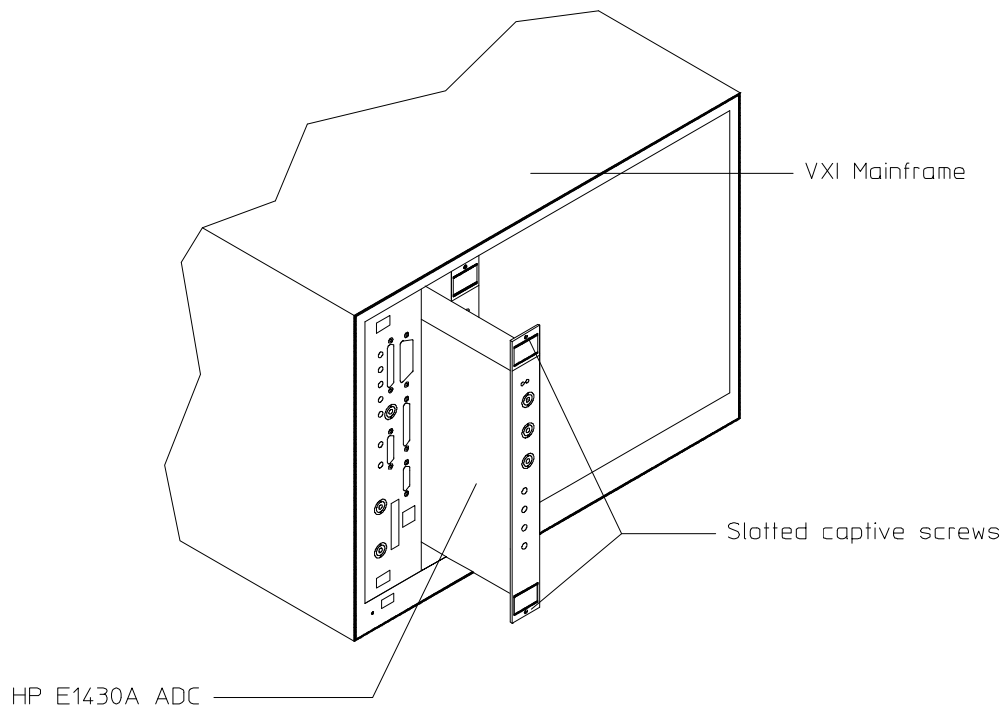

To install the C library interface

- Using an HP-UX operating system and one of the following:

- HP Series 300 Computer
- HP Series 700 Computer
- HP V/382 Embedded Computer

Do the following to install the C library interface:

- 1** Log in as root.
- 2** Insert the E1430A HP-UX tape into the tape drive.
- 3** Type `/etc/update`.
See the *HP-UX Reference* manual for information on the update command.

- Using a Windows or DOS operating system and one of the following:

- Personal Computer
- HP RADI-EPC7 Embedded Computer

The C library files are on the *E1430A Programming Software* disk. To copy these files from a floppy disk to your hard drive, see the following example:

- 1** Insert the HP E1430A Programming Software disk into drive A:
- 2** Type `mkdir c:\E1430`
- 3** Type `xcopy /s A:*. * c:\E1430`

To install the compiled SCPI (C-SCPI) driver

- Using an HP-UX operating system and one of the following:

- HP Series 300 Computer
- HP Series 700 Computer
- HP V/382 Embedded Computer

Two driver files are named E1430.o, but they are not identical. One file is for the C-SCPI preprocessor program and the other is linked to the C-SCPI library. The files are placed in the `/usr/e1430/cscpi/inst` and `/usr/e1430/cscpi/preproc` directories during the update process.

After you install C-SCPI, do the following to install the C-SCPI driver:

- 1** Log in as root.
- 2** Insert the E1430A HP-UX tape into the tape drive.
- 3** Type `/etc/update` to install the C library interface.
See the *HP-UX Reference* manual for information on the update command.
- 4** Type `/usr/hp7500/bin/build_cscpi`.

- C-SCPI is not supported on the Windows or DOS operating system.

To install the downloadable SCPI driver

The SCPI driver is downloaded into the HP E1405/06 Command Module.

Using an HP-UX operating system and one of the following:

- HP Series 300 Computer
- HP Series 700 Computer
- HP V/382 Embedded Computer

The downloadable version of the driver is named E1430. To accommodate older methods of downloading drivers, the driver files E1430.DU and E1430.DC are also included. The update process places these files in the `/usr/e1430/scpi` directory.

The utility, `vxidldux`, downloads the E1430 file into the Command Module. Either the Series 300 or the Series 700 version of this utility is taken off the update tape depending on the file set chosen.

Do the following to install the SCPI driver:

- 1** Set the HP 1405/06 Command Module's HP-IB address to 0000 1001 (9).
- 2** Connect an HP-IB cable from your computer to the HP E1405/06 Command Module.
- 3** Log in as root.
- 4** Insert the E1430A HP-UX tape into the tape drive.
- 5** To install the C library interface, type `/etc/update`.
See the *HP-UX Reference* manual for information on the update command.
- 6** Type `/usr/e1430/bin/vxidldux -h1 -d/dev/hpib7 -c ``diag:dram:cre 0;:diag:boot" /usr/e1430/scpi/E1430.DU`.

See application note E1401-90021 if you have difficulty; or the `VXIdldux` description in the UNIX[®] manual for more details.

UNIX[®] is a registered trademark of UNIX System Laboratories Inc. in the U.S.A. and other countries.

Using a Windows operating system and one of the following:

- Personal Computer
- HP RADI-EPC7 Embedded Computer

Use the HP VXI Installation Consultant (HP VIC) to install the SCPI driver.

- 1** Connect an RS-232 cable (HP 24542U) from your computer to the HP E1405/06 Command Module.
- 2** Insert the "SCPI Driver for Command Module" disk into your computer.
- 3** Start HP VIC.
- 4** Select the HP E1430A from the "HP INSTRUMENTS" list.
If the HP E1430A did not appear on the list, make sure the "SCPI Driver for Command Module" disk is in the computer's disk drive and restart HP VIC.
- 5** Follow the instructions provided by HP VIC.

HP VIC steps you through the installation procedure then tests the modules using the *tst? command. HP VIC may time out before the test is finished and display a "timed out" message. If this occurs, exit HP VIC and send the *tst? command. For instructions on sending the *tst? command, see chapter 3, "Troubleshooting the HP E1430A."

Using a DOS operating system and one of the following:

- Personal Computer
- HP RADI-EPC7 Embedded Computer

To download the driver, do the following:

- 1** Connect an RS-232 cable from your computer to the HP E1405/06 Command Module.
- 2** Insert the "SCPI Driver for Command Module" disk into drive A: on your computer.
- 3** Type A :
- 4** Type \VXIDLD.

See the HP E1405/06 Command Module *User's Guide* for more information.

To store the module

Store the module in a clean, dry, and static free environment.

For other requirements, see storage and transport restrictions in chapter 2, "Verifying Specifications."

To transport the module

- **Package the module using the original factory packaging or packaging identical to the factory packaging.**
Containers and materials identical to those used in factory packaging are available through Hewlett-Packard offices.
- **If returning the module to Hewlett-Packard for service, attach a tag describing the following:**
 - Type of service required
 - Return address
 - Model number
 - Full serial numberIn any correspondence, refer to the module by model number and full serial number.
- **Mark the container FRAGILE to ensure careful handling.**
- **If necessary to package the module in a container other than original packaging, observe the following (use of other packaging is not recommended):**
 - Wrap the module in heavy paper or anti-static plastic.
 - Protect the front panel with cardboard.
 - Use a double-wall carton made of at least 350-pound test material.
 - Cushion the module to prevent damage.

Caution

Do not use styrene pellets in any shape as packing material for the module. The pellets do not adequately cushion the module and do not prevent the module from shifting in the carton. In addition, the pellets create static electricity which can damage electronic components.

2

Verifying Specifications

To verify specifications

The HP E1430A VXI ADC requires a complete performance test every 24 months to verify conformance to its published specifications. The performance tests take about 1.5 hours to complete.

A program for automating the performance tests is included in the software supplied with the HP E1430A. This program, "pt1430", will sequence through the tests, prompt you to set up test equipment, perform the measurements required, and print a test record. Optionally, the program can control some of the test equipment if the equipment is connected via HP-IB.

There are two versions of the performance test software, one for each of the following computer environments:

- The HP V/382 controller. Software part number: E1430-19411 (DAT)
- A DOS Personal Computer with the HP 82335B HP-IB interface, connected to a VXI Command Module. Software part number: E1430-19409 (DOS disk)

Recommended Test Equipment

The following table lists the recommended equipment for the HP E1430A's performance tests and adjustments. You may substitute other equipment for the recommended model if the equipment meets or exceeds the listed critical specifications.

Recommended Test Equipment

Instrument	Critical Specifications	Recommended Model [Alternates]	Test Type
Printer	compatible with controller		
Controller	see previous page		
AC calibrator	amplitude accuracy, 2 V, 12 kHz, driving 40 mA: ± 600ppm	Fluke 5700A*† [Fluke 5200A]* [Daytron 4200/4700]*	P, A
Synthesizer	frequency range: 0 to 10 MHz frequency accuracy: 1ppm amplitude accuracy: ±0.6 dB distortion: -30 dBc	HP 3325A/B* [HP 3335A]*	P, A
Source for flatness test	freq. range: 100 kHz to 4 MHz flatness: ±0.06 dB	Fluke 5700A OPT 03*† [HP 3335A]*	P
Network analyzer	frequency range: 100 kHz to 4 MHz full 1-port calibration capability	HP 4195A [HP 3577A/B] [HP 8751A] [HP 3589A]	P
Transmission/ reflection kit [alternate: 50 ohm s-parameter test set]	frequency range: 100 kHz to 4 MHz compatible with network analyzer	HP 41952A [HP 35677A and HP 35678A] [HP 87512A] [HP 35689A]	P
Precision 50 ohm termination	return loss, 0 to 4 MHz: 52 dB	HP 909C OPT 200 013	P
Adapter	BNC(f) to type N	HP 1250-0780	P
Feedthrough/termination	impedance: 50 ohm ± 1 ohm	HP 11048C [Pomona 4119-50]	P, A
BNC Cable (2 required)	48 inch, 50 ohm	HP 8120-1840	P, A
BNC Tee		HP 1250-0781	P, A
Adapter (2 required)	BNC to dual banana	HP 1251-2277	P, A
Adapter	BNC to alligator clip	Pomona 2631‡	A
Alignment tool	adjustment screwdriver with long insulated shaft	Sprague-Goodman†† JFD-7104-8	A

Test type: P = performance test, A = adjustment

* = this equipment is HP-IB controllable

Alternate models in [square brackets]

† John Fluke Manufacturing Co., Inc., PO Box C9090, Everett, WA 98206 U.S.A. (206) 347-6100

‡ ITT Pomona Electronics, 1500 East Ninth Street, Pomona, CA 91769 U.S.A. (714) 469-2900

FAX (206) 629-3317

†† Sprague-Goodman Electronics, New Hyde Park, NY 11040 U.S.A.

Notes on the Test Equipment:

An AC calibrator is required for the amplitude accuracy test and the adjustments, and is recommended for the flatness test.

When connecting the calibrator, it is important to use “External Sense” and to connect the sense signal as close as possible to the unit under test.

To use the calibrator for the flatness test, it must have a “Wideband” output with a frequency range of at least 4 MHz. A synthesizer may be substituted for the flatness test.

A synthesizer is required for the range accuracy, frequency accuracy, and distortion tests.

A network analyzer and test set are required only for the “Return Loss” test. You will also need a precision 50 ohm termination, open and short, to calibrate the measurement. This program does not automatically control the network analyzer.

Measurement Uncertainty

Test	Recommended Equipment		Other Equipment	
	Uncertainty	Ratio	Uncertainty	Ratio
Self Test	NA	NA	NA	NA
Amplitude Accuracy	440 ppm	7.8 : 1		
Flatness	0.4 %	7.3 : 1		
Range Accuracy	616 ppm	5.6 : 1		
Frequency Accuracy	1 ppm	7.0 : 1		
Distortion	-30 ; -80 dBc	10 : 1		
Input Noise Density	0.6 dB	10 : 1		
Spurious Responses	-130 dBfs	10 : 1		
Return Loss	52 dB	4 : 1		

To start pt1430 in the HP-UX environment

Follow these steps to install and run the Performance Test software using an Embedded (or MXI bus) VXI controller running HP-UX. When the performance test program is running, follow the steps under “To run the tests.”

- 1** If the HP E1430A software has not already been installed, follow the software installation instructions in Chapter 1, “Installing the HP E1430A”.
- 2** The logical address of the HP E1430A module must be in the servant area of the controller. Note the logical address (factory default is 129).
- 3** To automatically control the test equipment during the test, connect the test equipment to the controller using the HP-IB cable. Note the HP-IB addresses of the equipment.
- 4** Exit any application programs that use the HP E1430A module.
- 5** At the HP-UX prompt, type

```
/usr/e1430/ptest/pt1430
```

The program should begin by displaying the Performance Test Main Menu. If not, check the screen for error messages. The message

```
Unable to open SICL session with address vxi
```

indicates the Standard Instrument Control Library has not been installed. The message

```
unable to load library - /usr/lib/libsicl.sl
```

indicates the SICL has not been installed, or the program version does not match the HP-UX operating system version.

To start pt1430 in the DOS environment

Follow these steps to install and run the Performance Test software using a DOS Personal Computer with an HP 82335B HP-IB card, connected to an HP E1405/06 VXI Command Module. When the performance test program is running, follow the steps under "To run the tests."

- 1** Install the test software on the PC's hard disk. For example, to copy the Performance test files from a floppy disk in drive A to the PC's hard disk, type these lines at the DOS prompt:

```
MKDIR \PT1430  
  
CD \PT1430  
  
COPY A:*.*
```

- 2** Configure the Command Module, install it in slot 0 of the VXI mainframe, and connect it to the PC via HP-IB. Switches on the Command Module should be set to enable it as VXI system controller, logical address 0, Servant Area large enough to include the HP E1430A module, HP-IB address 09, and HP-IB controller disabled. See the Command Module user's manual.
- 3** The logical address of the HP E1430A module must be in the servant area of the controller. Note the logical address (factory default is 129).
- 4** To automatically control the test equipment during the test, connect the test equipment to the PC using HP-IB cables. Note the HP-IB addresses of the equipment.
- 5** To start the program, at the DOS prompt, type

```
PT1430
```

To run the tests

Use the arrow keys to move through the menus in this program. Use the up and down keys to select an item from the current menu. Use the right arrow key to go to the next menu. Use the left arrow key to return. In some menus, you can enter information. Press "Enter" when finished with each entry.

Menu settings are automatically saved in the "ptest.ini" configuration file which is recalled when you run the program again.

"Program Settings" menu:

Set "Pause on Test Fail" to "ON" if you want the program to stop whenever a measurement exceeds the test limits. Press the "Enter" key to toggle.

Set "Beep" to "ON" if you want the program to beep when it stops. Press the "Enter" key to toggle.

The "Test Record File" is the name of the file that the program will use to record test results. You can print this file by selecting "Print Test Record" in the main menu. The file name limit for DOS is eight characters.

The "Print Command" is the command executed to print the test record. The default is "copy %s prn" for DOS and "pr -F %s | lp - F dlaser" for UNIX.

The "Sequence Directory" is the directory the program will search for test sequence files. Test sequence files are read by this program and contain a list of tests and measurements. Sequence files end in ".seq". The sequence is selected under the "Test sequence" menu.

"Unit-Under-Test" menu:

Use this menu to enter information such as the serial number and the customer name. This information will be printed on the test record. The "Logical Addr." entry is used by the program to address the unit under test. It must match the switch setting on the module.

"Test Equipment" menu:

Use these menus to select test equipment and record information about the equipment. The information will be printed on the test record. If you want the program to automatically control some of the equipment, HP-IB address must be entered. Additional help text is provided in this menu.

“Test Sequence” menu:

Use this menu to select the test sequence. Test sequences are stored in files and have names such as “Perform.seq” or “Adjust.seq”. Use the up/down keys to highlight one sequence, then use the left arrow key to return to the main menu.

The performance tests give a high level of confidence that the HP E1430A is operating properly and conforms to its published specifications. The adjustment procedures are to be done when the HP E1430A does not meet its specifications; they are not required for routine maintenance. Before starting the adjustments, allow the HP E1430A to warm up for at least one hour.

“Start Testing” menu:

This will display another menu so you can choose to run all the tests in the sequence, choose a starting test, or choose one test to run.

“Print Test Record” menu:

Highlight this menu item, then press “Enter” to print the test record. The command used to print the test record can be set in the “Program Settings” menu.

Specifications

Specifications apply after 15 minutes warm-up.

Abbreviations

dBfs = dB relative to full scale of a particular range.

dBc = dB relative to the carrier or fundamental amplitude.

Fs = Sample frequency.

Analog Input

Input Modes:

DC coupled, AC coupled, grounded;
Single-ended, differential

Input Ranges:

Input voltage ranges (clipping voltages):

$\pm 8\text{ V}$	$+28\text{ dBm}$	$\pm 0.5\text{ V}$	$+4\text{ dBm}$	$\pm 31.25\text{ mV}$	-20 dBm
$\pm 4\text{ V}$	$+22\text{ dBm}$	$\pm 0.25\text{ V}$	-2 dBm	$\pm 15.625\text{ mV}$	-26 dBm
$\pm 2\text{ V}$	$+16\text{ dBm}$	$\pm 0.125\text{ V}$	-8 dBm	$\pm 7.8125\text{ mV}$	-32 dBm
$\pm 1\text{ V}$	$+10\text{ dBm}$	$\pm 62.5\text{ mV}$	-14 dBm		

Maximum input voltage without damage: 8 Vrms for any time interval > 10 ms

Input Impedance:

50 ohm $\pm 1\%$ DC; >40 dB return loss to 4 MHz; DC coupled or grounded modes only

AC Coupling:

In ac coupled mode, a 0.2 μF $\pm 10\%$ capacitor is placed in series with the input signal. Maximum dc voltage without damage is $\pm 50\text{ V}$ when ac coupling is used.

Common Mode Characteristics:

Impedance to chassis ground: 47 ohms $\pm 10\%$ in parallel with 0.04 μF $\pm 10\%$, differential input mode; < 0.1 ohms, single ended input mode

Maximum common mode current without damage: ± 1 Amp peak; diode clamped to < $\pm 1\text{ V}$ peak

Common mode response: < $(-90+20 \times \text{LOG}(V_{\text{com}}))$ dBfs, range $\geq 125\text{ mV}$
< $(-80+20 \times \text{LOG}(V_{\text{com}}))$ dBfs, range = 62.5 mV
< $(-65+20 \times \text{LOG}(V_{\text{com}}))$ dBfs, range $\leq 31.25\text{ mV}$

Note

The common mode source for these characteristics is a sine wave voltage source of V_{com} mV applied through a 50 ohm series resistor. The characteristics apply for source frequencies < 4 MHz.

Accuracy

Resolution:

Raw ADC resolution: 23 bits, two's complement

After digital zoom and filter operations: 32 bits, full resolution mode;
16 bits, reduced resolution mode

Amplitude Accuracy:

Absolute voltage measurement accuracy: ± 0.03 dB (< 100 kHz, ± 1 V input range, 25°C, analog alias filter on, digital decimation filters off, DC coupled)

Range accuracy relative to ± 1 V range: ± 0.03 dB (for all ranges), <100 kHz

Alias filter off mode: ± 0.02 dB relative to alias filter on mode, 12 kHz

Temperature drift: < 0.001 dB per °C of deviation from 25°C (typical)

DC Offset:

Programmable DC offset:

Resolution: <0.05% of input range clipping voltage

Range (minimum): $\pm 50\%$ of input range clipping voltage, range ≥ 62.5 mV

Input bias current: < 64 μ A (in parallel with 50 ohm input load)

DC offset voltage vs temperature (% of clipping voltage, typical):
< $\pm 0.01\%$ / °C for 62.5 mV and higher ranges; < $\pm 0.1\%$ / °C for ranges < 62.5 mV

Filtering

Total Frequency response

Total Frequency response is:

$$H(f) = H_{analog}(f) \cdot H_{digital, N} \left(\frac{f-f_0}{f_s} \right)$$

where:

f = input signal frequency

f₀ = zoom center frequency (zero in baseband mode)

f_s = ADC sampling frequency (10 MHz with standard internal clock)

N = Digital filter bandwidth selector N = 0, 1, 2, ..., 24

Analog frequency response (H_{analog})

Analog Flatness (peak to peak):

Alias filter on: 0.03 dB, f ≤ 100 kHz; 0.25 dB, f ≤ 2.5 MHz; 0.8 dB, f ≤ 4 MHz

Alias filter off: 0.25 dB, f ≤ 4 MHz; 3 dB typical, f < 20 MHz

Stopband rejection: 100 dB, f > 6 MHz, alias filter on

Analog Frequency Response Function (nominal), with alias filter off:

$$H_{analog}(f) = \frac{1}{2 \prod_{n=1} [(1-s/c_n)(1-s/c_n^*)]} \Big|_{s=j2\pi f}$$

n	c_n / 2π
0	20 MHz
1	40 + j × 52 MHz
2	50 + j × 120 MHz

Analog Frequency Response Function (nominal), with alias filter on:

$$H_{analog}(f) = \frac{\prod_{n=1}^5 [(1-s/a_n)(1-s/a_n^*)]}{(1-s/b_0) \prod_{n=1}^5 [(1-s/b_n)(1-s/b_n^*)]} \Bigg|_{z=e^{j2\pi f}}$$

n	a _n (Radians / second)	b _n (Radians / second)
0		-8.2909964×10^6
1	$j 3.4904432 \times 10^7$	$-7.5372809 \times 10^6 + j 9.0528495 \times 10^6$
2	$j 3.7024164 \times 10^7$	$-5.7386094 \times 10^6 + j 1.6425689 \times 10^7$
3	$j 4.2617433 \times 10^7$	$-3.7379055 \times 10^6 + j 2.1470763 \times 10^7$
4	$j 5.6601087 \times 10^7$	$-2.0233064 \times 10^6 + j 2.4424917 \times 10^7$
5	$j 1.0424240 \times 10^8$	$-6.3191539 \times 10^5 + j 2.5754323 \times 10^7$

Digital filter response (H_{digital}):

Amplitude Flatness (1≤N≤24): +0/-0.23 dB, |f-f₀| < 0.36 × fs/2^N

Stopband rejection (1≤N≤24): > 111 dB, |f-f₀| > 0.64 × fs/2^N

Frequency Response Function:

$$H_{digital,N} \left(\frac{f-f_0}{f_s} \right) = \begin{cases} 1, N = 0 \\ \prod_{n=1}^N \left[\left(\frac{z^3 + 2z^2 + 2z + 1}{4z^3 + 2z} \right)^5 \right] \Bigg|_{z=e^{j2^n \pi (f-f_0)/f_s}}, N > 0 \end{cases}$$

Dynamic Range

ADC sample clock ≥ 10 MHz unless otherwise specified.

(Note: if you reset the HP E1430A and your application depends on the dynamic range specifications, allow at least 20 seconds after the reset for the ADC correction to settle before beginning your measurements.)

Signal to Noise Ratio:

(The reference signal is a sine wave with peaks at the clipping voltage of the current range.)

Alias filter on: 70 dB, range ≥ 62.5 mV; 62 dB, range ≤ 31.25 mV

Alias filter off: 66 dB, range ≥ 62.5 mV; 53 dB, range ≤ 31.25 mV

Input Noise Density: (Alias filter on)

Range = 62.5 mV to 8 V:

-136 dBfs/Hz for frequencies > 100 kHz

-134 dBfs/Hz for frequencies between 10 kHz and 100 kHz

-130 dBfs/Hz for frequencies between 2 kHz and 10 kHz

$(-97 - 10 \times \text{LOG}(f))$ dBfs/Hz for frequencies < 2 kHz (typical),
where (f) = frequency in Hz.

Range = 7.8125 mV to 31.25 mV:

-127 dBfs/Hz for frequencies ≥ 200 kHz

-122 dBfs/Hz for frequencies between 20 kHz and 200 kHz

$(-79 - 10 \times \text{LOG}(f))$ dBfs/Hz for frequencies < 20 kHz (typical),
where (f) = frequency in Hz.

Input Noise Density in absolute dBm level can be calculated with the following formula:

$$\text{range} + (10 \times \text{Log}(\text{measurement bandwidth})) - \text{dBfs}$$

Spurious Signals:

(Between 0 to 4 MHz; terminated with 50 ohms at input connector)

< -110 dBfs, alias filter on, DSP clock = ADC clock

< -95 dBfs, alias filter on, DSP clock \neq ADC clock

< -70 dBfs, alias filter off, DSP clock = ADC clock

Distortion:

(Includes aliased distortion components)

Harmonic distortion:

< -80 dBc or < -110 dBfs, with additional signal applied > -20 dBfs

< -80 dBc or < -100 dBfs, without other signals applied

Intermodulation (two tones each at -6 dBc):

< -80 dBc or < -110 dBfs, with additional signal applied > -20 dBfs

< -80 dBc or < -100 dBfs, without other signals applied

Distortion vs Input Signal Level

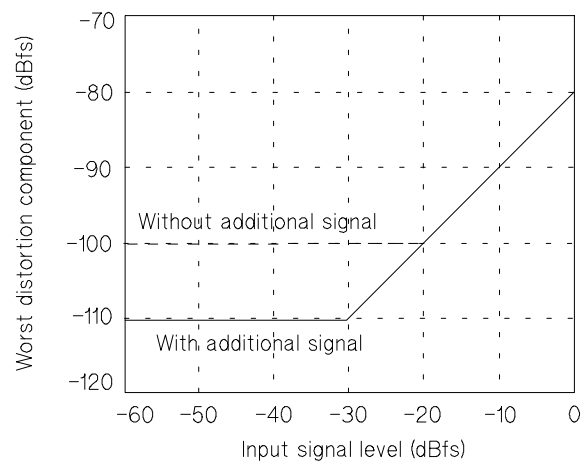

Phase Noise:

($F_{in} < 4$ MHz, vibration < 0.01G)

Phase noise density (single sideband power density):

< -128 dBc/Hz, $\Delta f = 100$ Hz

< -122 dBc/Hz, $\Delta f = 50$ Hz

< -92 dBc/Hz, $\Delta f = 5$ Hz

Discrete sidebands (5 Hz < Δf < 1 MHz):

< -110 dBc, internal clock

< -80 dBc, internal clock distributed on backplane (typical)

Note

The sideband specification for the backplane-distributed clock requires that all modules in the mainframe comply with the VXI 1.4 specification for ECL trigger lines; and that the 10 MHz VXI system clock be turned off. External clock input must be disconnected when not being used for ADC clock.

Clock

Clock I/O Connections:

External ADC clock input (ExtClk): BNC input compatible with TTL, ECL, and >-6 dBm sine waves. AC coupled with input impedance of 1 kohm above 10 kHz. ± 10 V absolute maximum input without damage

Clock Extender Input: ECL-10K compatible, 50 ohm termination to -2 V, SMB, -7 V to $+0.5$ V without damage

Clock Extender Output: ECL-10K compatible, SMB

Sync Extender Input: ECL-10K compatible, SMB, -7 V to $+0.5$ V without damage

Sync Extender Output: ECL-10K compatible, SMB

Clock sources:

ADC clock:

Internal 10 MHz clock (optional 10.24 MHz)

External clock, BNC input (the external clock frequency must be >100 kHz if the DSP clock is the ADC clock, and must be <4.6 MHz if the DSP clock is internal)

ECL clock, SMB input

DSP clock:

Internal 10 MHz clock (optional 10.24 MHz)

ADC clock (ADC clock must be > 100 kHz in this mode)

Internal Clock:

Frequency: 10 MHz (optional 10.24 MHz)

Accuracy: ± 70 Hz, 0 °C to 40 °C

Typical jitter: < 10 ps rms, 1 s interval (see phase noise specification for spectral content of jitter)

Typical sampling skew:

Within mainframe: 5 ns

Between mainframes: 20 ns, clock extended via a 1 M coaxial cable

Trigger

Trigger Sources:

External TTL

Level

LOG(Magnitude)

Software (via register write)

Slope:

Positive/negative

Threshold:

Level Trigger: $V_{\text{range}} \times N/128$, $-128 \leq N \leq 128$; hysteresis is $V_{\text{range}}/32$

LOG(Magnitude) Trigger: $V_{\text{range}}(\text{dBm}) - N \times 0.375 \text{ dBm}$, $0 \leq N \leq 255$; hysteresis is 1.5 dB

External Trigger Input:

TTL, BNC, $\pm 10 \text{ V}$ absolute maximum input without damage

Trigger Offset:

Resolution (in output sample periods):

1 sample, 32-bit complex data

2 samples, 16-bit complex or 32-bit real data

4 samples, 16-bit real data

Maximum pre-trigger delay: $1,048,575 \times$ trigger offset resolution

Maximum post-trigger delay: $8,388,607 \times$ trigger offset resolution

Programming

All functions are programmable via the VXI register interface.

Center Frequency:

Resolution: ADC clock frequency \div (1024 \times 109)

Range: \pm ADC clock frequency \div 2

Filtering and Decimation:

Bandwidths (–15 dB): $\pm 0.5 \times F_s/2^N$, $1 \leq N \leq 24$

(See the frequency response section for filter characteristics)

Output sample rate: $F_s/2^N$ (Nyquist sampled), $2 \times F_s/2^N$ (2 \times over-sampled)

Data output:

Formats: real, complex

Resolution: 16 bits, 32 bits

Output Ports: VME data transfers; Local Bus data transfers

Transfer rate:

40 MByte/s, local bus, block mode

20 MByte/s, local bus, continuous mode

3 MByte/s, VME

Block sizes: 8, 16, 32, ... , 8388608 bytes

Measurement modes:

Block mode (individually triggered blocks); continuous mode

Information Available in Read Registers:

Manufacturer's Code: 4095 Decimal (Hewlett-Packard)

Model Code: 0454 Decimal (E1430A)

Other: Logical Address, Status, Measurement Loop State, Data

Status bits: Data word ready, Data block available, Armed, Measurement done, Overload, ADC error.

Interrupts:

Two independent priority interrupts initiated by masked status bits.

General

Standards Compliance:

VXI (Rev. 1.4); Register based; A16/D16

Conducted Susceptibility:

The HP E1430A meets VXI section B.8.6 only for frequencies ≥ 50 kHz.

Power Required:

DC voltage/current: +5 V/4.2 A, -5.2 V/4.2 A, -2 V/0.3 A, +12 V/0.3 A, -12 V/0.1 A

Dynamic current: +5 V/0.5 A, -5.2 V/0.2 A, -2 V/0.1 A, +12 V/0.05 A, -12 V / 0.02 A

Size:

Single slot, C-size VXI module

Dimensions: 14 inches deep, 9.2 inches high, 1.2 inches wide
(approx 36 cm deep, 23 cm high, 3 cm wide)

Weight: 3.9 pounds (approx 1.8 kg)

Environmental:

Temperature:

Operating: 0° to 55° C

Storage: -20° to 65° C

Humidity, non-condensing:

Operating: 10% to 90% at 40° C

Storage: 10% to 90% at 40° C

Altitude:

Operating: 4600 m (15,000 ft)

above 2285 m (7500 ft), derate operating temperature by -3.6° C per 1000 m
(-1.1° C per 1000 ft)

Storage: 4600 m (15,000 ft)

Calibration interval: 1 year

Warm-up time: 15 minute

Filter characteristics for nominal analog alias filter

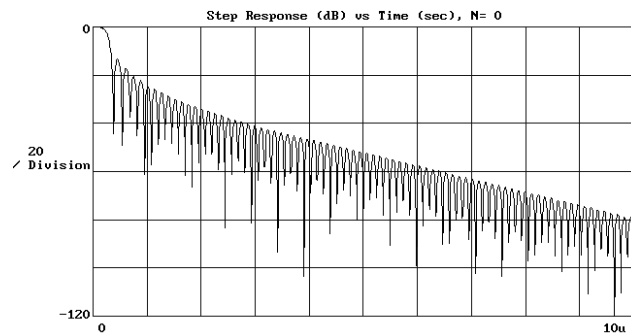
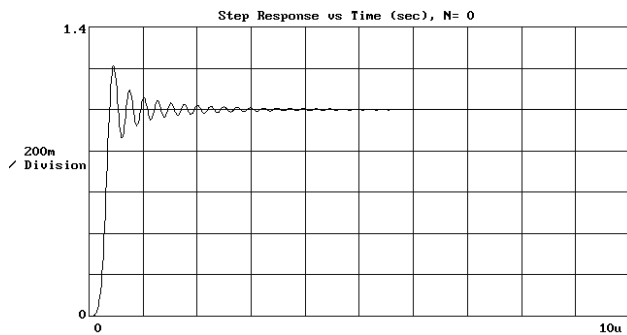
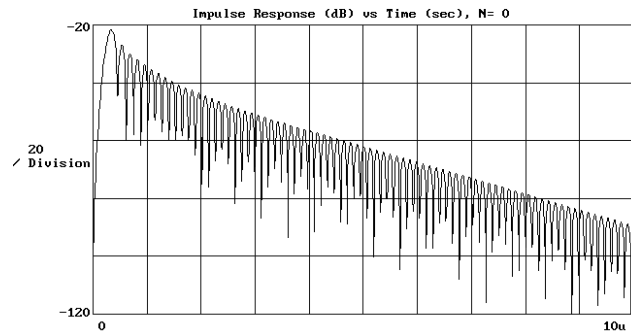
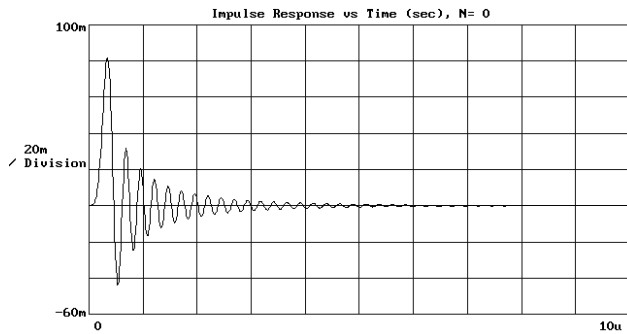
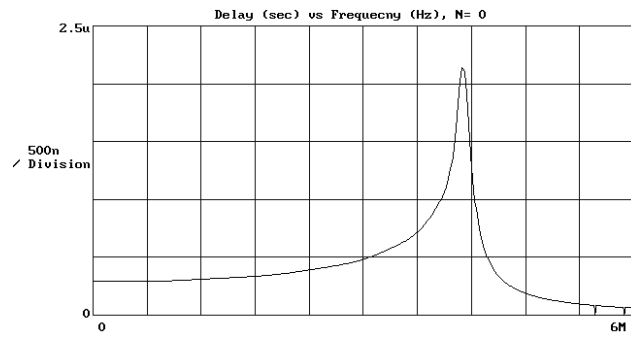
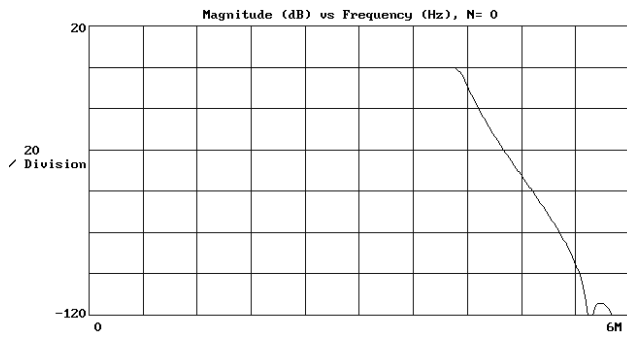
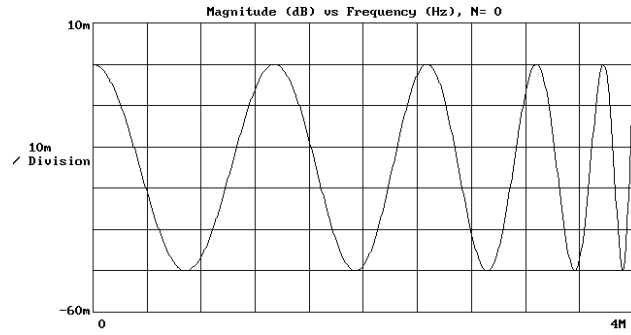
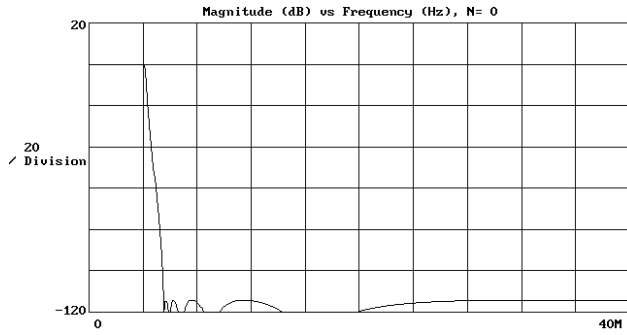

Filter characteristics for 3rd pass digital filter + analog filter (dominated by digital)

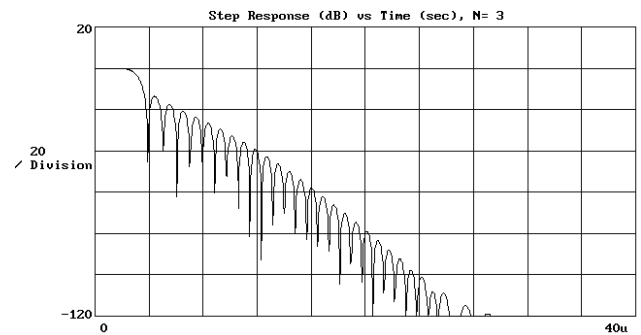
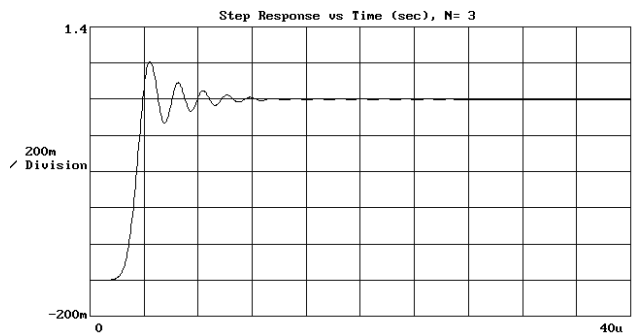
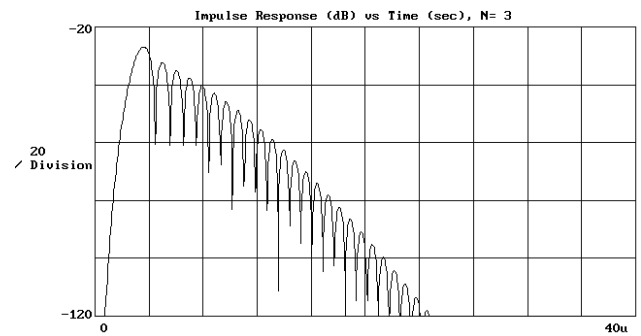
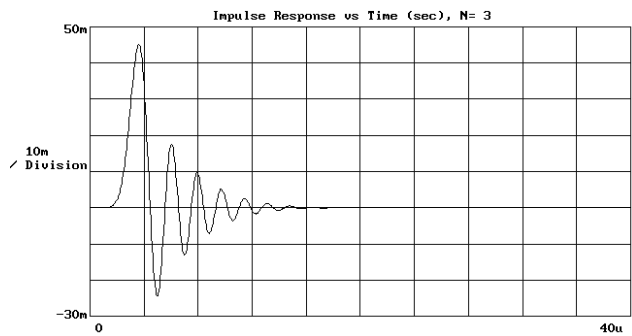
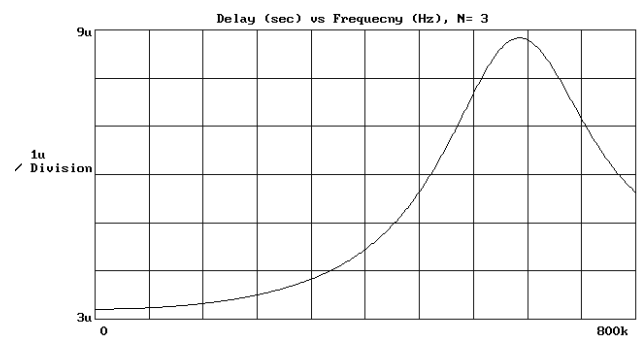
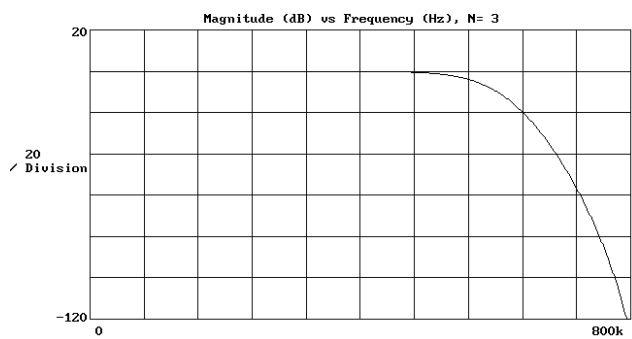
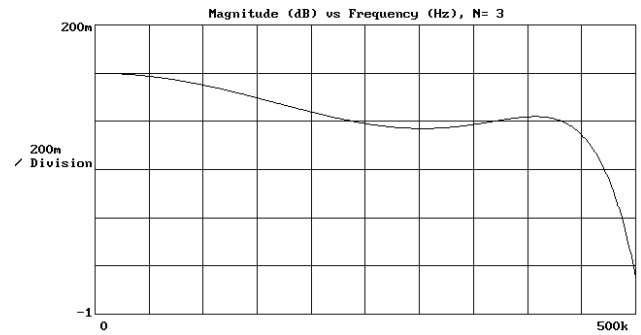
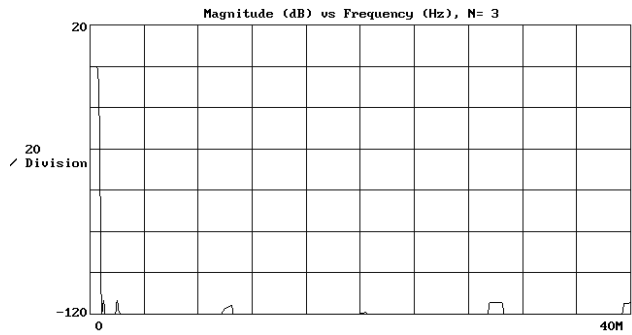

Filter characteristics with all alias filtering turned off (based on approximate model)

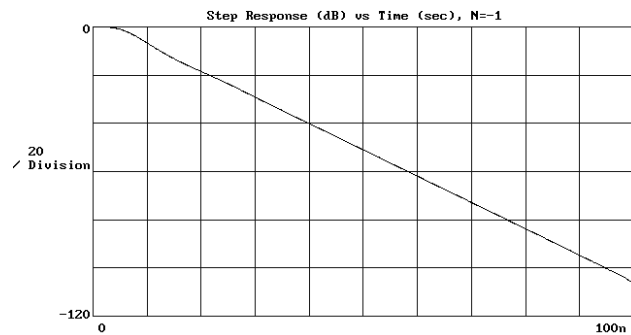
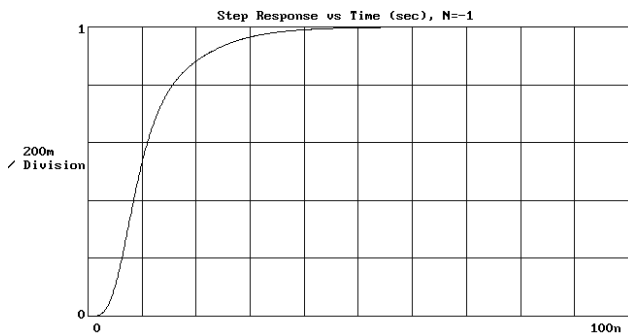
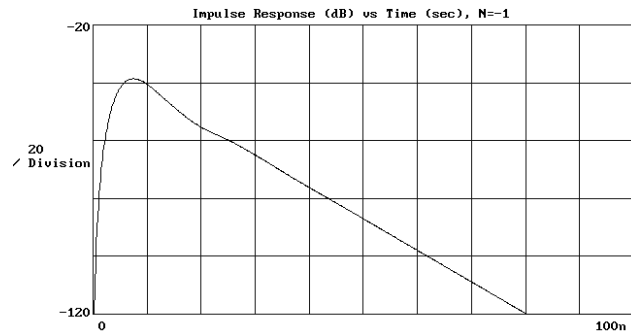
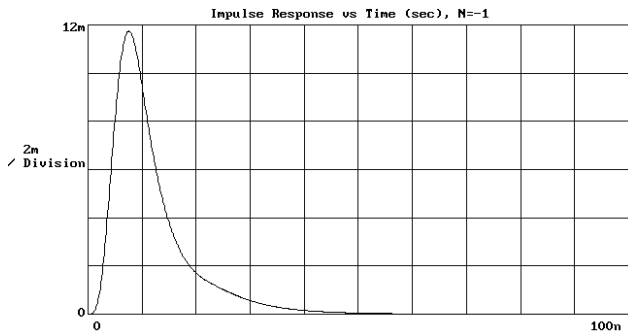
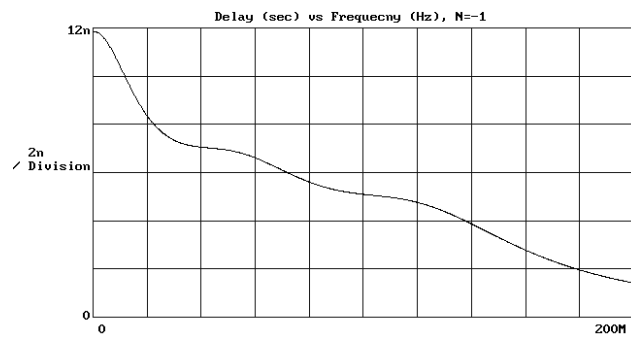
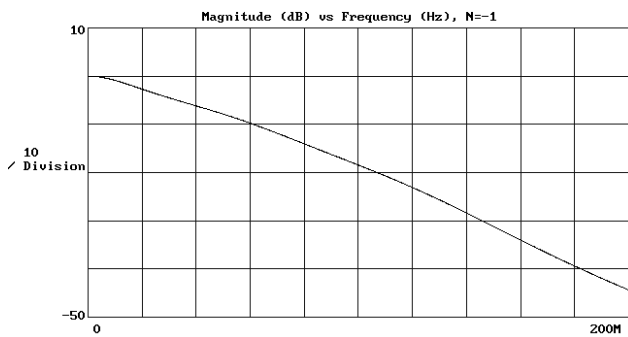
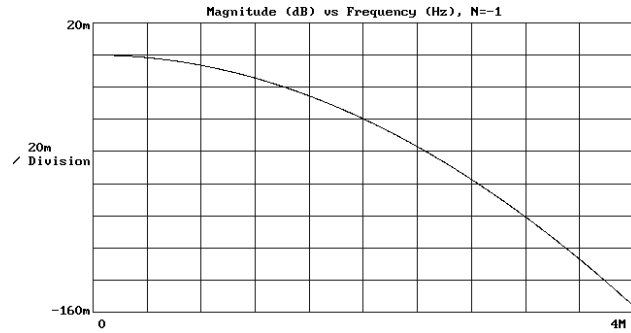
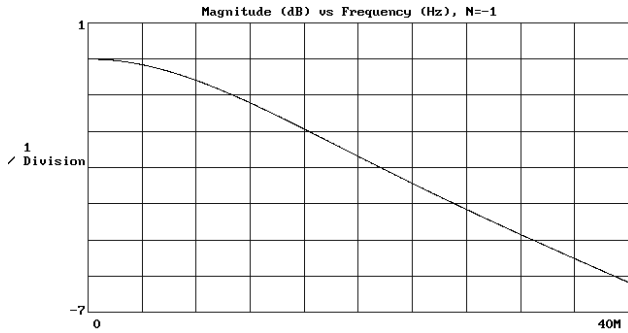

3

Troubleshooting the HP E1430A

To troubleshoot using HP-IB interface

Equipment Required: "C" size mainframe
HP E1405/06A Command Module with HP E1430A SCPI driver
Series 200/300 computer with an HP-IB interface and RMBASIC

- Step 1. Configure the system.
- 1 Set the mainframe's power switch to standby (⌘).
 - 2 Set the HP E1405/06A Command Module's HP-IB address to 0000 1001 (9).
 - 3 Set the HP E1430A module's logical address to 0000 1000 (8).

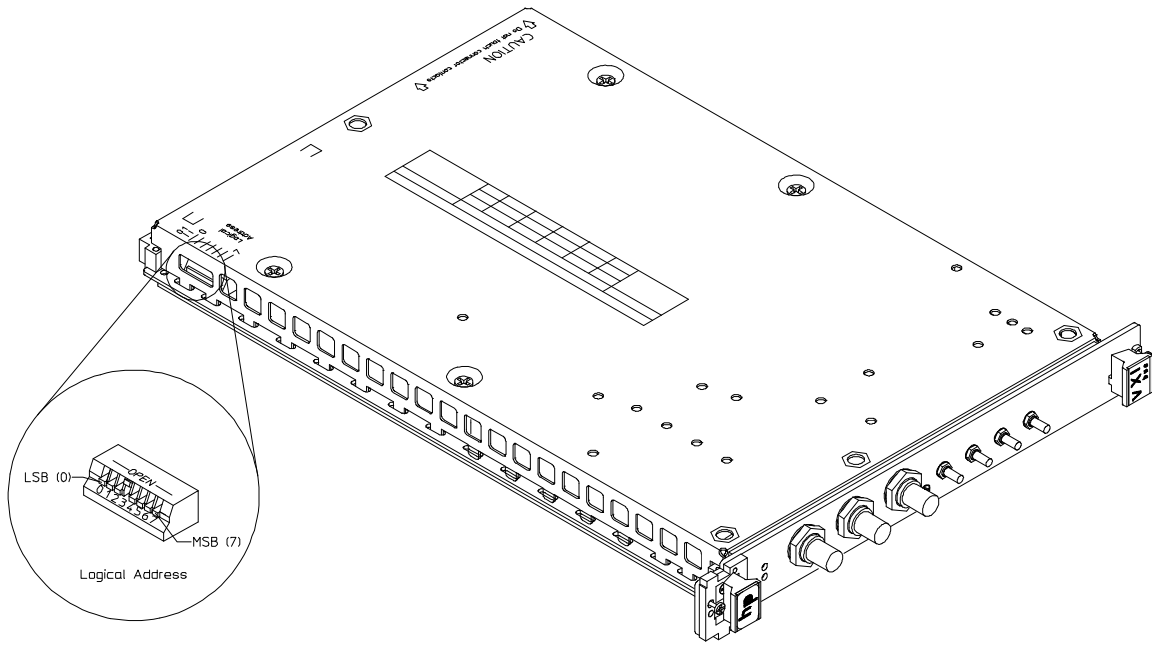

- 4 Connect an HP-IB cable from the computer to the command module's HP-IB port.
- 5 Set the mainframe's power switch to on (I).

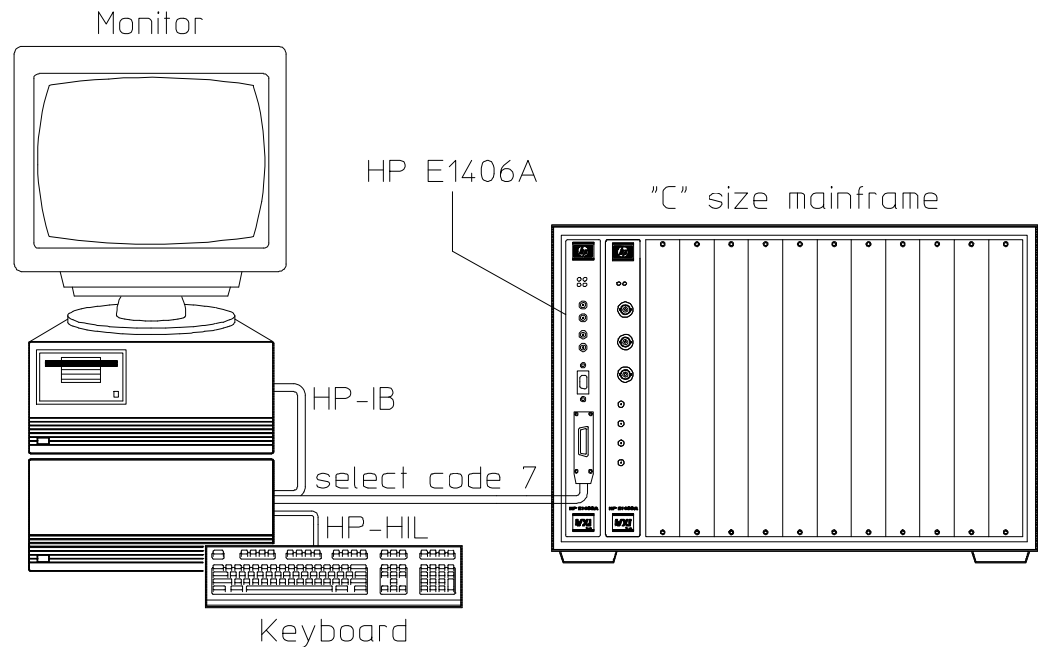

□ Step 2. Test the HP E1430A module.

1 Type in and run the following program:

```
10 DIM Response$(80)
20 OUTPUT 70901;"*idn?"
30 ENTER 70901;Response$
40 DISP Response$
50 END
```

The response should be "Hewlett-Packard, E1430A, *A.nn.nn*," where *A.nn.nn* is the module's software revision. If there is no response within 20 seconds, check your setup (cabling, address switch settings, baud rate), verify that the E1430A SCPI driver is installed in the command module, and run the program again.

2 Type in and run the following program:

```
10 OUTPUT 70901;"*tst?"
20 WAIT 150
30 ENTER 70901;Response$
40 DISP Response$
50 END
```

This test should take approximately 3 minutes.

3 If the response is +0, the self test has passed. If a failure is still suspected, see "To troubleshoot using performance tests."

HP E1430A User's Guide
To troubleshoot using HP-IB interface

- 4 If the response is +1, the HP E1430A module is faulty and an error message is placed in the error queue. To read this message, type in and run the following program:

```
10 OUTPUT 70901;"syst:err?"  
30 ENTER 70901;Response$  
40 DISP Response$  
50 END
```

- 5 If the error message is "ADC Error" or "Overload," perform the A/D Converter adjustments. For all other error messages, replace the module. See chapter 5, "Replaceable Parts," for the replacement procedure and exchange module part number.

To troubleshoot using performance tests

This section describes how each test is performed and how to troubleshoot performance test failures. For more information, see page 2-7 (“To run the tests”). A list of recommended test equipment is on page 2-3.

Caution

To protect circuits from static discharge, remove or replace modules only at static-protected work stations.

- 1** Install and start the performance test software following the steps on page 2-5, “To start pt 1430 in the HP-UX environment,” or page 2-6, “To start pt 1430 in the DOS environment.”
- 2** Select and run the self test.
This test runs the diagnostic routines provided with the HP E1430A software library. No external test equipment is needed. If a failure occurs check the error message. If the error message is “ADC Error” or “Overload,” perform the A/D Converter adjustments. For all other error messages, replace the module.
- 3** If there is no error message and a failure is still suspected, continue with the following performance tests.

Amplitude Accuracy

This test uses an AC Calibrator to apply a voltage to the HP E1430A Input. The AC Calibrator must use external sensing to avoid voltage drop due to cable resistance. If the test fails, perform the A/D Converter adjustments.

Flatness

This test measures amplitude flatness by stepping a signal through the frequency range. If a failure occurs, replace the module (flatness is not a field adjustment).

Range Accuracy

This test measures the relative accuracy between ranges. A signal is applied to the HP E1430A input and measured. The HP E1430A range is changed and the same signal is measured again. The measurements are done on HP E1430A ranges that use an internal 6dB attenuator to minimize any amplitude changes due to return loss variation. If a failure occurs, replace the module.

Frequency Accuracy

This test measures the accuracy of the HP E1430A internal sample clock. The HP E1430A measures a 4 MHz signal on a narrow (300 Hz) frequency span. The measured frequency is used to compute sample clock error in Hz. If a failure occurs, perform the frequency adjustment.

Distortion

This test measures harmonic distortion by using the HP E1430A's internal anti-alias filter to improve the distortion of a signal from a synthesizer. The test frequency is chosen so a harmonic is aliased to about 4.5 MHz, where the anti-alias filter will also reject synthesizer spurs. Measurements are done at two amplitudes: nearly full scale and 20 dB below full scale. If a failure occurs, replace the module.

Input Noise Density

This test measures residual noise in dB relative to full scale per Hz of bandwidth. If a failure occurs, perform the A/D Converter adjustments. If the test still fails, replace the module.

Spurious Responses

This test measures the level of some spurious residual responses. With no signal applied, the HP E1430A does a measurement on the most sensitive range using a 600 Hz frequency span centered around the frequency of a sub-harmonic of the sample clock.

If a failure occurs, check that the screws are tight on the internal shields, the module cover, and the module connections to the mainframe. If the test still fails, replace the module.

Return Loss

This test measures the return loss of the HP E1430A input impedance. A standard 50 Ohm reflection measurement is done on several HP E1430A ranges. If a failure occurs, replace the module.

4

Adjusting the HP E1430A

To adjust the module

Caution

To protect circuits from static discharge, perform these adjustments only at static-protected work stations.

This section contains the adjustment procedures for the HP E1430A. Use these adjustments to return the module to specified operating accuracy if the performance tests indicate a specification failure.

The HP E1430A is adjusted using the performance test software. Install and start this software by following the steps on page 2-5 ("To start pt1430 in the HP-UX environment") and page 2-6 ("To start pt1430 in the DOS environment"). Select "Adjust.seq" on the "Test Sequence" menu. This sequence will prompt you to set up the test equipment and step you through the adjustments.

The test equipment required for the adjustments is listed on page 2-3.

All adjustments can be done without removing the HP E1430A covers (see the illustration below). The right side of the module must be accessible while it is in the mainframe. A Hewlett-Packard VXI Development mainframe is recommended. A standard VXI mainframe that has only the controller and the HP E1430A module installed, on the left-hand side, can also be used.

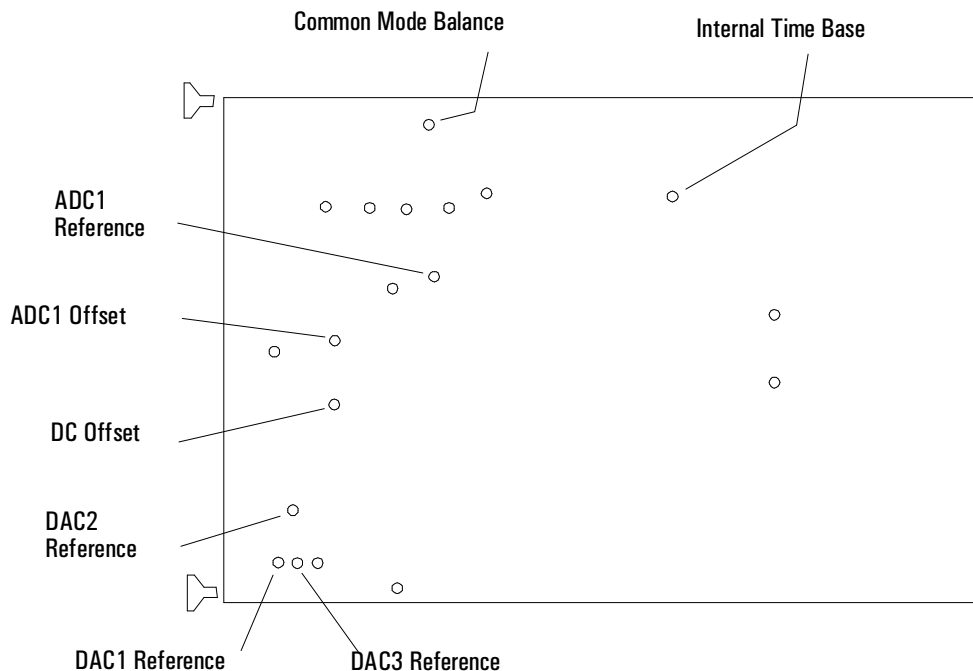

Set up for adjusting and measuring common mode characteristics

The common mode source for measuring the common mode characteristics is a sine wave voltage source applied through a 50 ohm series resistor, as shown in this diagram. See page 2-10 for more information about the common mode characteristics.

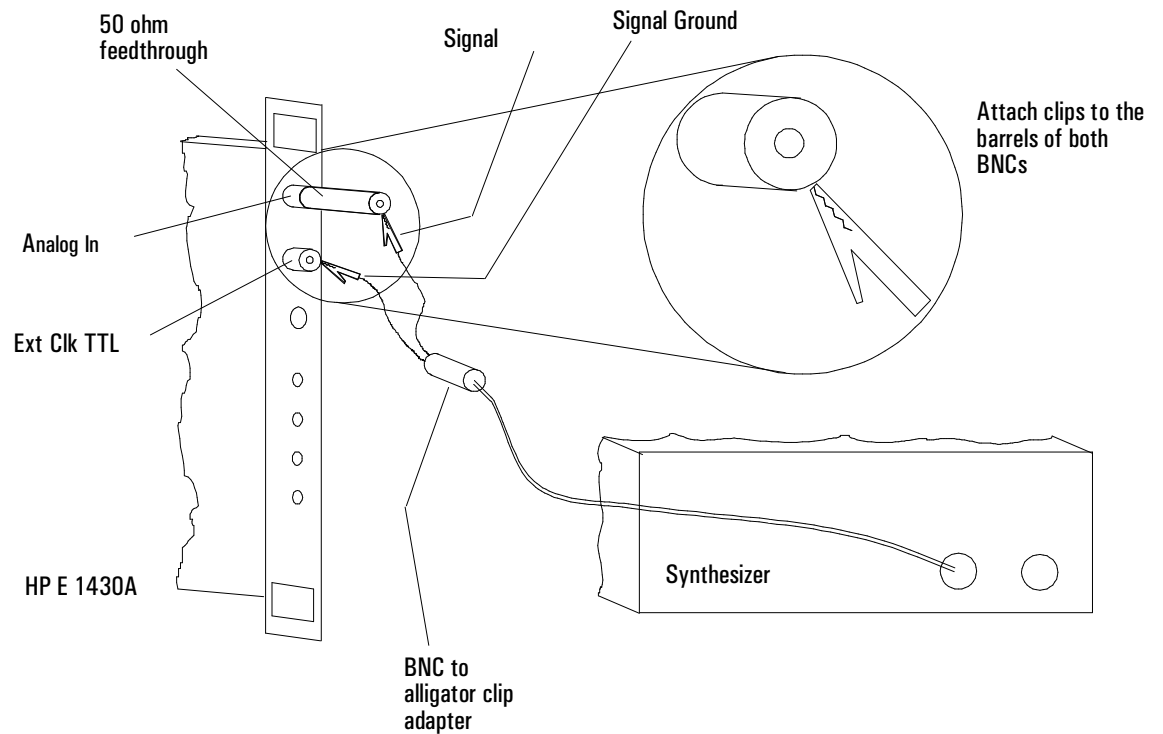

5

Replaceable Parts

Replaceable Parts

The HP E1430A VXI ADC Module's circuit assemblies cannot be individually replaced. The assemblies must be matched and adjusted at the factory. Therefore, if the HP E1430A fails, order the exchange module. However, selected hardware can be replaced if damaged. Replacement parts are listed in the following three tables:

- Module
- Covers
- Front Panel

Caution

The module is static sensitive. Use the appropriate precautions when removing, handling, and installing to avoid unnecessary damage.

Ordering Information

To order a part listed in one of the tables, quote the Hewlett-Packard part number (HP Part Number), the check digit (CD), indicate the quantity required, and address the order to the nearest Hewlett-Packard sales and service office (see the inside back cover of this guide). The check digit verifies that an order has been transmitted correctly, ensuring accurate and timely processing of the order. The first time a part is listed in the table, the quantity column (Qty) lists the total quantity of the part used in the module. For the corresponding name and address of the manufacturers' codes shown in the tables, see "Code Numbers."

Direct Mail Order System

Within the U.S.A., Hewlett-Packard can supply parts through a direct mail order system. Advantages of the Direct Mail Order System are:

- Direct ordering and shipment from the HP Parts Center.
- No maximum or minimum on any mail order. There is a minimum order for parts ordered through a local HP sales and service office when the orders require billing and invoicing.
- Transportation charges are prepaid. A small handling charge is added to each order.
- No invoicing. A check or money order must accompany each order.
- Mail order forms and specific ordering information are available through your local Hewlett-Packard sales and service office. See the inside back cover of this guide for a list of Hewlett-Packard sales and service office locations and addresses.

Code Numbers

The following table provides the name and address for the manufacturers' code numbers (Mfr Code) listed in the replaceable parts tables.

Mfr No.	Mfr Name	Address
05791	Lyn Tron Inc.	Burbank, CA 91505 U.S.A.
12085	Schlegel Corp.	Rochester, NY 14692 U.S.A.
28480	Hewlett-Packard Company	Palo Alto, CA 94304 U.S.A.
30817	Instrument Specialties Co. Inc.	Placentia, CA 92670 U.S.A.
83486	ELCO Industries Inc.	Rockford, IL 61101 U.S.A.
98291	ITT Sealectro	New Britain, CT 06051 U.S.A.

Module

Caution

Before installing the HP E1430A module into the VXI mainframe, be sure to set the mainframe power switch to standby () or remove power from the mainframe. Inserting or removing the module with power on can damage the module or mainframe.

Caution

To protect circuits from static discharge, remove or replace modules only at static-protected work stations.

HP Part Number	CD	Qty	Description	Mfr Code	Mfr Part Number
E1430-69201	2	1	HP E1430A EXCHANGE MODULE (STD) †	28480	E1430-69201
E1430-69202	3	1	HP E1430A EXCHANGE MODULE (OPT AYD) †	28480	E1430-69202

† This information applies to modules with serial numbers ≥ 3419 .
For modules with serial numbers < 3419 , see chapter 6, "Backdating".

Do the following when you replace the HP E1430A module:

- 1** Write the faulty module's serial number on the exchange module's blank serial number tag using a fine point permanent marker.
- 2** Write the faulty module's serial number on the exchange module's Certificate of Calibration.
- 3** Remove all customer labels from the faulty module and place on the exchange module.
- 4** Set the exchange module's logical address configuration switch to the faulty module's original logical address for customer configuration convenience.

Covers

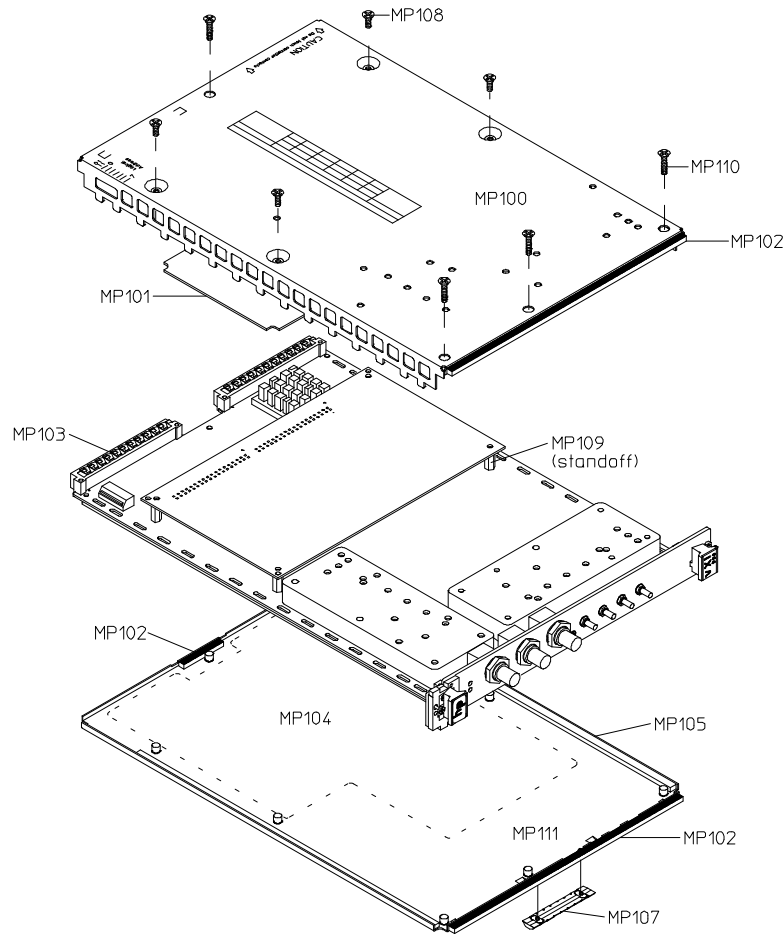

Ref Des	HP Part Number	CD	Qty	Description	Mfr Code	Mfr Part Number
MP100	E1430-00202	9	1	SHTF CVR-TOP ALSK	28480	E1430-00202
MP101	E1430-44101	9	1	SHTF NSLTR-TOP PLCR	28480	E1430-44101
MP102	E1485-40602	2	2	GSKT RFI-FRT PNL,ADH LG SD	12085	5774-191W-0
MP103	E1450-01202	5	4	STMP SHLD-RFI GRND "VXI"	28480	E1450-01202
MP104	E1430-44102	0	1	SHTF NSLTR-BTTM PLCR	28480	E1430-44102
MP105	E1485-40601	1	2	GSKT-RFI,BTTM CVR ADH SHT SD	12085	5774-194W-0
MP107	8160-0686	6	1	STMP FNGRS-RFI STRP BECU	30817	786-185
MP108	0515-1135	7	4	SCREW-MACH M3 X 0.5 25MM-LG	28480	0515-1135
MP109	0380-2070	4	4	STDF-HXMF M3.0 14.0MMLG SSTPA	05791	SS5172-14.0-01
MP110	0515-0372	2	4	SCREW-MACHINE ASSEMBLY M3 X 0.5 8MM-LG	28480	0515-0372
MP111	E1430-00203	0	1	SHTF CVR-BOTTOM AL	28480	E1430-00203

Front Panel

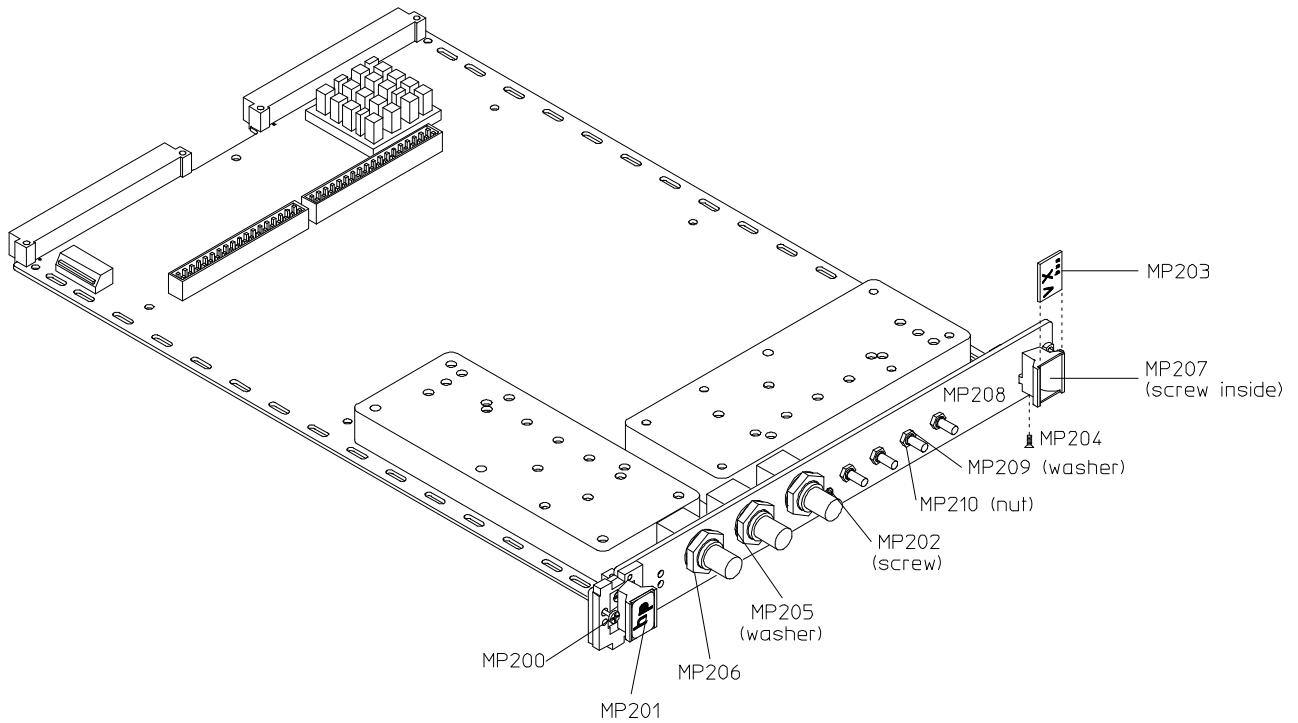

Ref Des	HP Part Number	CD	Qty	Description	Mfr Code	Mfr Part Number
MP200	0515-1968	4	2	SCR-MCH M2.5 11MMLG PHSPS SST	28480	0515-1968
MP201	E1400-84106	2	1	MOLD KIT-TOP EXTR HDNL"HP"	28480	E1400-84106
MP202	0515-1946	8	1	SCR-MCH M3.0 6MMLG FHTX SST	28480	0515-1946
MP203	E1400-84105	1	1	MOLD KIT-BTTM EXTR HDL"VXI"	28480	E1400-84105
MP204	0515-0368	6	2	SCREW-MACHINE ASSEMBLY M2.5 X 0.45	28480	0515-0368
MP205	2190-0068	5	3	WASHER-LK INTL T 1/2 IN .505-IN-ID	28480	2190-0068
MP206	2950-0154	2	3	NUT-HEX-DBL-CHAM 1/2-28-THD .078-IN-THK	28480	2950-0154
MP207	0515-1375	7	2	SCR-MCH M2.5 6MMLG FHTX SST	83486	343-300-02506
MP208	E1430-00201	8	1	PNL-FRT "E1430A" VXI ALPT	28480	E1430-00201
MP209	2190-0124	4	4	WASHER-LK INTL T NO. 10 .195-IN-ID	98291	3002-26
MP210	2950-0078	9	4	NUT-HEX-DBL-CHAM 10-32-THD .067-IN-THK	98291	40001-18-030-156

To remove the front panel

1 Using a 1/4-inch nut driver, remove the washers and nuts from the SMB connectors.

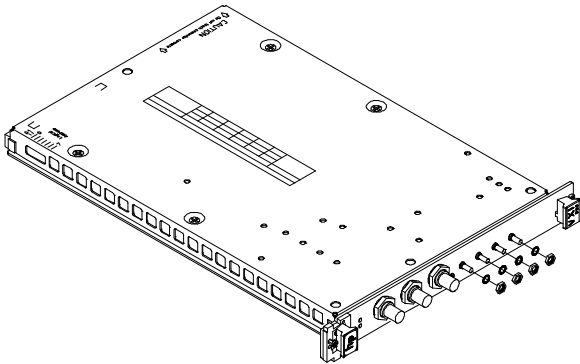

2 Using a 9/16-inch open-end wrench, remove the washers and nuts from the BNC connectors.

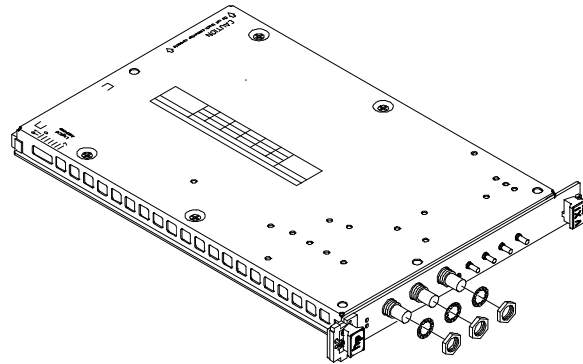

3 Using a T-8 torx driver, remove the screws that attach the handles. The screws come out from below. The screws pass through a gold spacer; be careful not to lose the spacer when the handle is removed.

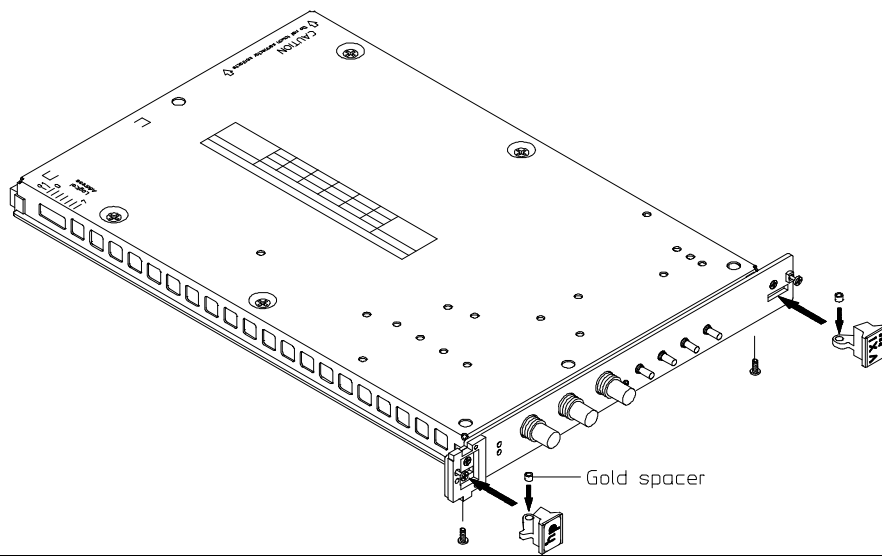

- 4** Using a T-10 torx driver, remove the screw that attaches the front panel to the main assembly.

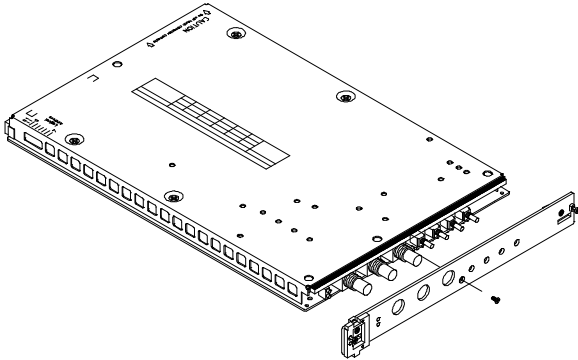

- 5** To replace the front panel with another that does not have its own side brackets, remove the brackets from the old front panel. Use a T-8 torx driver.

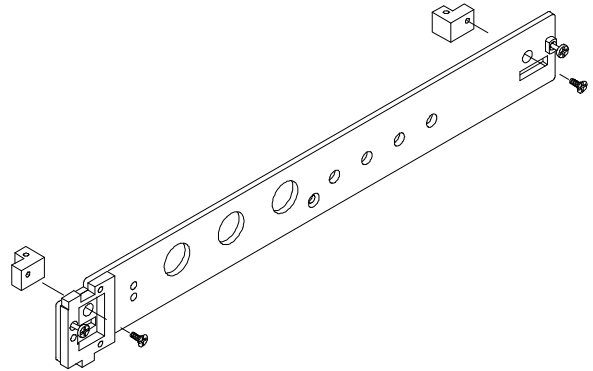

6

Backdating

Backdating

This chapter provides information necessary to modify this guide for modules that differ from those currently being produced. The information in this chapter documents earlier module configurations and associated servicing procedures.

With the information provided in this chapter, this guide can be corrected so that it applies to any earlier version or configuration of the module.

If module serial number prefix is	Make change
≤ 3245A	A
< 3419	B

Change A

The external clock in these modules is a single-ended BNC input that requires TTL levels. The following changes should be made to the manual.

- On page 2-16 , **Clock I/O Connections**, “External ADC clock input (ExtClk):” should be changed to read “BNC input compatible with TTL. AC coupled with input impedance of 1 kohm above 10 kHz. ±10 V absolute maximum input without damage.”
- On page 6-2 , **External Connections**, “External Clock Input (Ext Clk)” should be changed to read “This is a single-ended BNC input for TTL signals. The module can be programmed to use the positive edges of this signal as the ADC sample clock.”
- On page 6-7 , **Clock Generation**, paragraph 1, the last sentence should be changed to read “This signal must be TTL.”

Change B

The following table contains the information necessary to replace modules with serial numbers < 3419. The procedure for replacing the module is on page 5-3.

HP Part Number	CD	Qty	Description	Mfr Code	Mfr Part Number
E1430-69211	4	1	HP E1430A EXCHANGE MODULE (STD)	28480	E1430-69211
E1430-69212	5	1	HP E1430A EXCHANGE MODULE (OPT AYD)	28480	E1430-69212

7

Circuit Descriptions

Block Diagram and Description

Input Amplifier

The input amplifier provides an input termination which maintains good flatness to 4 MHz. The gain/attenuation of the input amplifier is programmable.

Under program control, the input signal can be ac coupled. This allows the system to measure low level ac signals in the presence of a large dc offset. The input can also be programmed to eliminate any dc offset.

Anti-alias Filter

Since the normal ADC sample rate is 10 MHz, a complete representation of the input signal can be achieved only for bandwidths up to 5 MHz. Frequency components above 5 MHz can cause ambiguous results (aliasing).

The anti-alias filter attenuates these high frequency components to reduce aliasing. The anti-alias filter in the HP E1430A is flat to 4 MHz and rejects signals above 6 MHz by at least 100 dB. Thus the 0-4 MHz frequency range of the sampled signal will be alias free. The filter's transition band from 4 MHz to 6 MHz will affect flatness and allow some aliasing in the sampled signal frequency range of 4 MHz-5 MHz.

In cases where alias filtering is not necessary the HP E1430A can be programmed to bypass the anti-alias filter. This allows the system to take advantage of the full 20 MHz sampler bandwidth. To avoid incorrect results, the alias filter bypass mode should be used with caution; it is not recommended for normal operation.

Sampling ADC

The heart of the HP E1430A is a precision Analog-to-Digital Converter (ADC). The ADC generates 23 bit outputs at a sample rate up to 10.24 MHz. It has very low noise density and very low distortion levels.

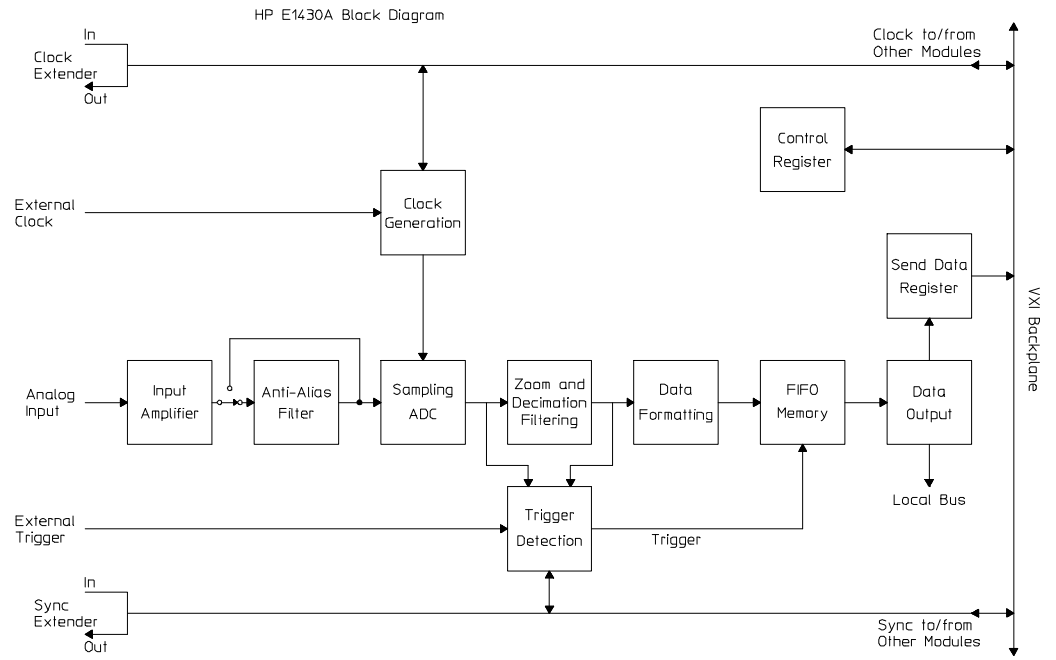

Zoom and Decimation Filtering

This section uses digital circuitry to allow programmable changes in the center frequency and signal bandwidth of the HP E1430A (zoom). This is done at high speed for real-time operation.

Bandwidth is controlled by a chain of digital low-pass filters (see the diagram on the next page). Each of the filters reduces the bandwidth by a factor of two (decimation). With the ADC sample rate (F_s) set to the standard internal 10 MHz rate, the bandwidth choices are ± 5 MHz, ± 2.5 MHz, ... ± 0.289 Hz around the programmed local-oscillator (LO) frequency.

Real and imaginary components of the signal are each computed to 32-bit precision, so the complex output of the decimation filtering block contains 64 bits. Whether or not all of these bits are stored in memory is programmable.

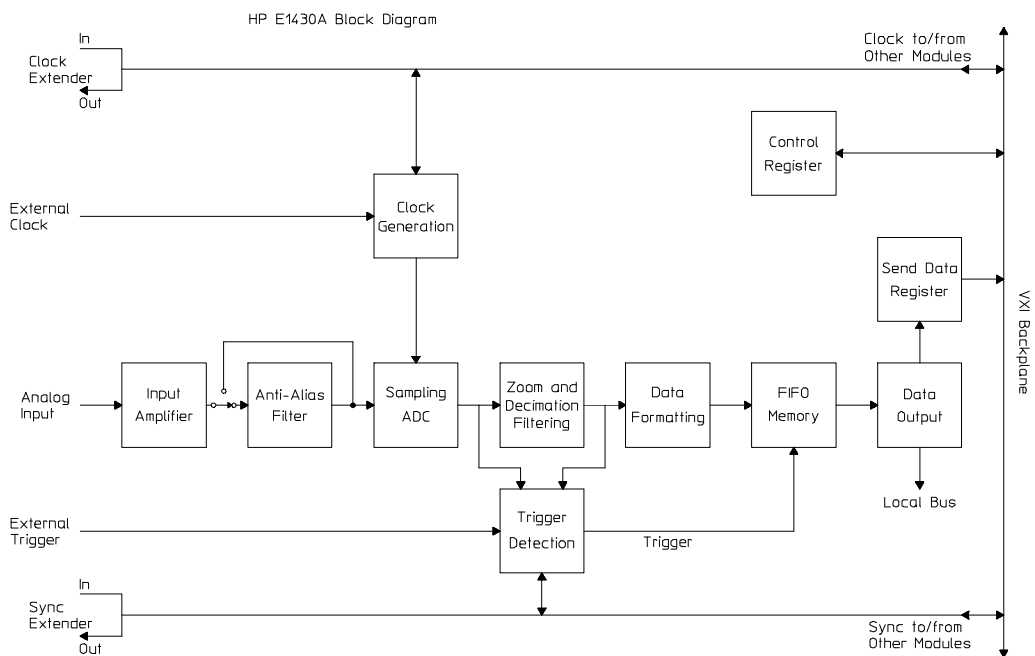
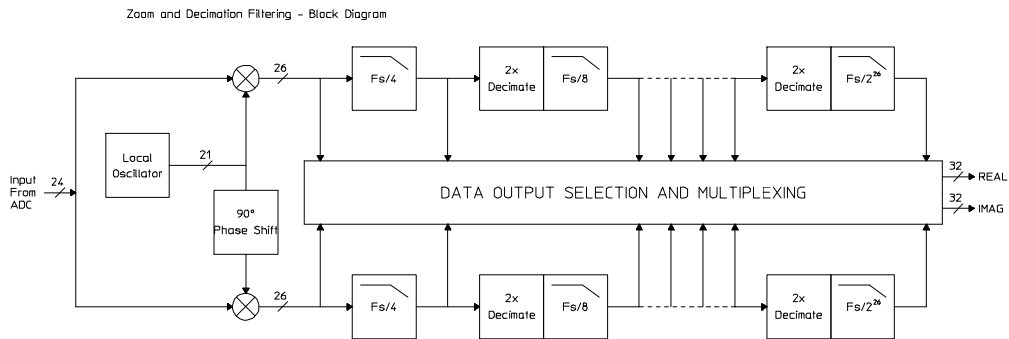

Data Formatting and FIFO Memory

The HP E1430A can be programmed to save the real component of the signal or to save the complete complex signal. The data precision can be set to 16 bits or 32 bits. Thus, each sample will occupy from two to eight bytes of memory in the FIFO. The data formatting block packs the selected data into 64-bit words which are stored in the FIFO memory. Since the standard FIFO depth is 1-Mword (8 MB), it is possible to hold up to 4-Msamples in memory at one time.

The memory may be configured either in block mode or in continuous mode. In block mode, data collection initiated by a trigger will proceed until a specified block length is captured. The measurement is then paused so that the data can be read out. Before a new block can be collected, the module must be re-armed and triggered again. This mode is useful in capturing single transient events or whenever the output data rate is too high to be read and processed in real time.

In continuous mode, data collection is initiated by a trigger and will continue as long as the FIFO does not overflow. Data may be read out of the memory while the measurement is in progress. If the reading of data is sufficiently fast, the FIFO will never overflow and the measurement will continue indefinitely. If the FIFO should ever overflow then the measurement will stop and wait for data to be read out, the measurement to be re-armed, and a new trigger. This mode of operation is useful for real-time applications that employ a high speed signal processor to continuously read and operate on each sample of data. Data can be read from the FIFO in bursts to accommodate pauses for such things as disk access times or block mode computations.

The effective trigger time may be offset from the actual trigger event by programming a trigger timing offset. Pre-trigger offset is limited to the physical depth of the FIFO memory. Post-trigger offset is limited to 2^{25} samples.

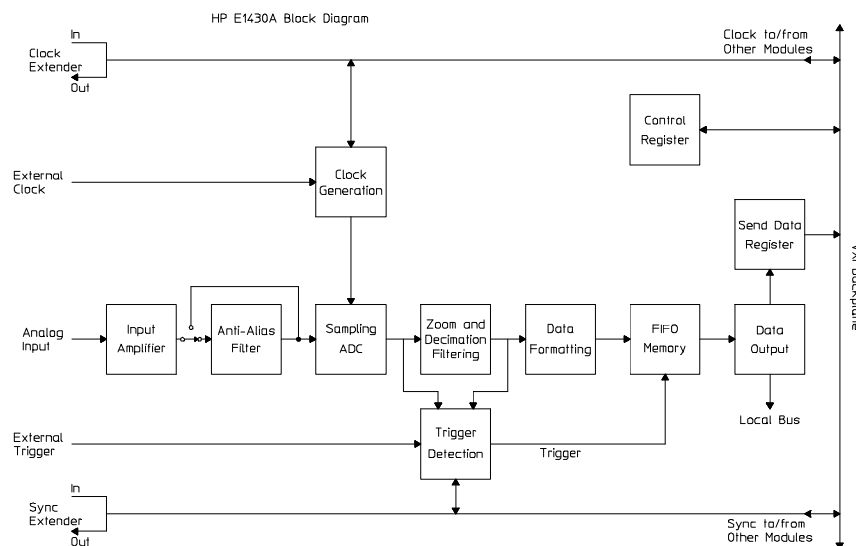

Data Output

There are two ways to output data from the HP E1430A: by way of the VXI backplane or by way of the local bus.

To use the VXI backplane, the HP E1430A can be programmed so that the output of the FIFO is sent to the Send Data register. Each 64-bit portion of the FIFO memory is sent to the 16-bit register as four separate words. The register can then be read by any controller compatible with the VME standard. Maximum data flow is about 2 MB/s.

The local bus allows data transfers over a high speed 8-bit ECL bus to an adjacent module (to the right) in the VXI mainframe. Multiple adjacent HP E1430A modules can send data to one signal processor module. The signal processor must be one which supports the Hewlett-Packard ECL local bus protocol, such as the HP E1485A/B. In addition to higher speed (up to 40 MB/s), the local bus has the advantage that data can be output at the same time that control signals are being sent over the VXI backplane.

In both of the data output modes, the samples must be read out sequentially, beginning with the sample following the trigger.

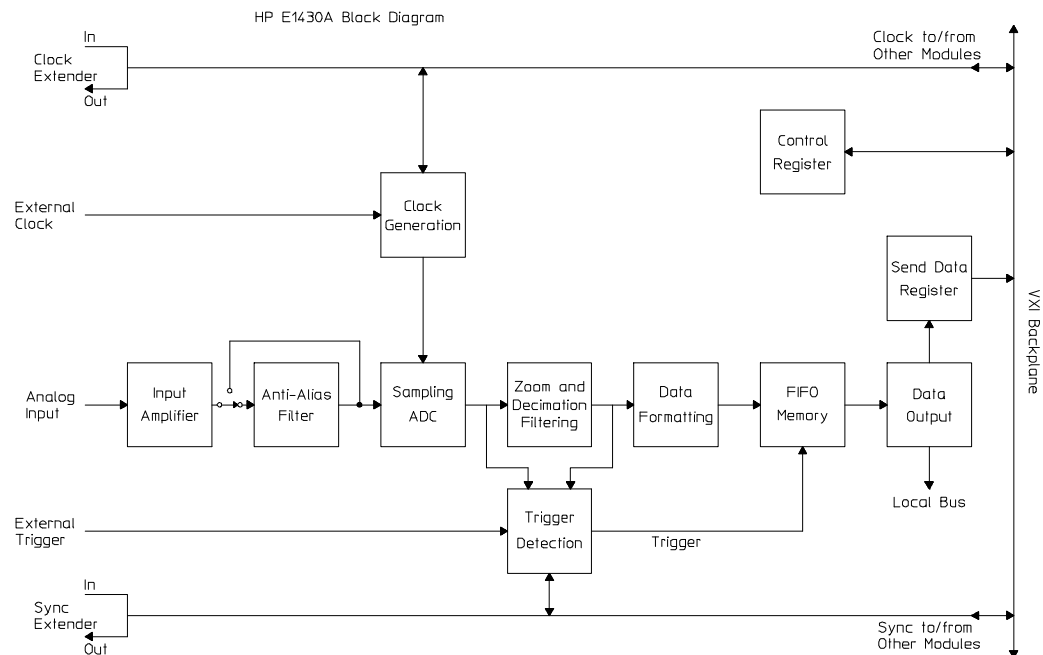

Clock Generation

The usual source for a clock signal is the 10 MHz (or optional 10.24 MHz) crystal oscillator inside the HP E1430A. However, the HP E1430A can also accept an external clock signal through a front-panel BNC ("Ext Clk"). This signal can be TTL, ECL, or sine wave.

In a system using more than one HP E1430A, the ADCs can be synchronized by programming them to use a common ECL line on the backplane. One of the modules can be the clock master that drives this line. This backplane clock can be extended to other mainframes by connecting the "Clk Out" SMB connector to the "Clk In" SMB connector on an HP E1430A in the second mainframe.

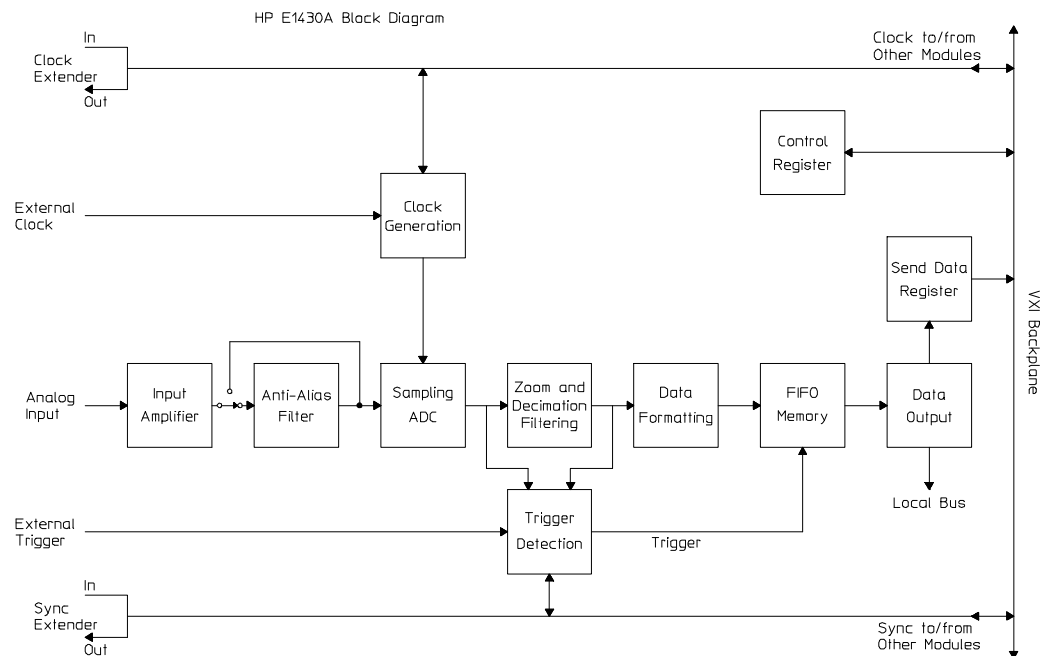
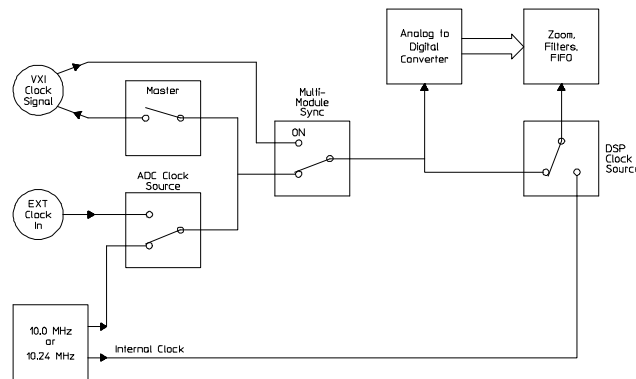

Trigger

The trigger event used to start a measurement can be generated in four different ways:

- Software trigger
- External TTL
- ADC threshold
- Log-magnitude

All triggering modes support slope selection. In ADC or log-magnitude mode the trigger threshold can be specified with hysteresis to prevent noise-generated triggers of the wrong slope. Log-magnitude triggering is based on the magnitude of the complex signal after zooming and filtering.

For external TTL mode, a trigger signal must be supplied at the "Ext Trg TTL" connector on the front panel.

Any HP E1430A module can trigger other HP E1430A modules using a shared sync line on the VXI backplane. This backplane sync line can be extended to other mainframes by connecting the "Sync Out" SMB connector to the "Sync In" SMB connector on a HP E1430A in the second mainframe. All modules in a synchronous system are triggered on the same ADC sample.

The HP E1430A hardware samples the trigger source once every sample clock, so the trigger condition must be present for at least one sample clock in order to be recognized.

Control Registers

The HP E1430A module is controlled using registers mapped into the 16-bit VXI address space. There are 24 writable and 18 readable registers; each has 16 bits.

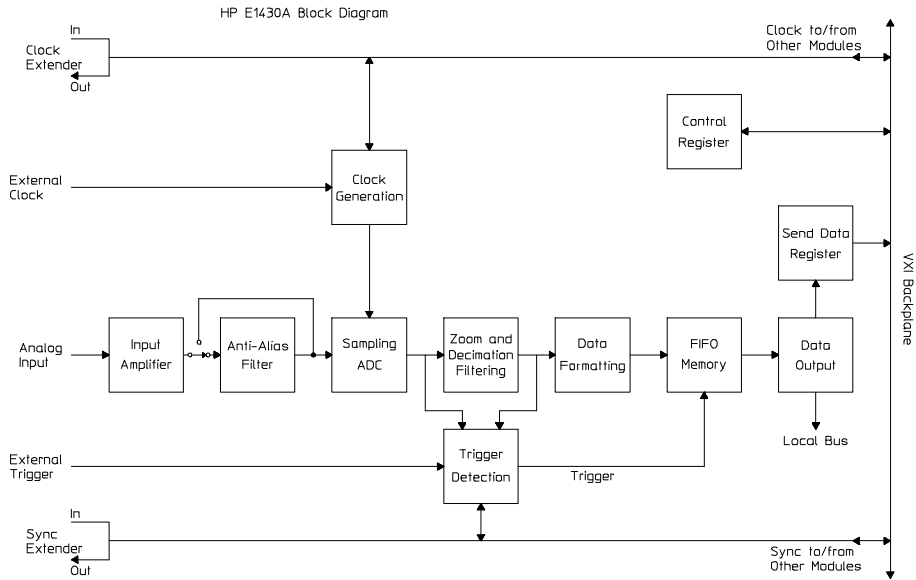

8

Using the HP E1430A

Front-panel Description

Status LEDs

Access

This LED lights whenever the module is being accessed via the VXI backplane.

Overload

This LED lights when the input range is exceeded, producing an overload in the ADC.

External Connections

Analog Input (Analog In)

This BNC connector is the main input to the ADC. It is a pseudo-floating single-ended input terminated into 50 ohms. The maximum signal level without damage is 7 volts rms.

External Clock Input (Ext Clk)

This is a single-ended BNC input for TTL, ECL, or sine wave signals. The module can be programmed to use the positive edges of this signal as the ADC sample clock.

Trigger Input (Ext Trg TTL)

This is a single-ended BNC input for TTL signals. The module can be programmed to use the positive or negative edges of this signal to trigger the acquisition of a block of data.

Sync Extender Output (Sync Out)

This SMB connector is an ECL output with a buffered version of the backplane sync line used for synchronization and triggering. It is used to extend the sync line from one mainframe to another.

Clock Extender Output (Clk Out)

This SMB connector is an ECL output with a buffered version of the sample clock line on the backplane of the mainframe. It is used to extend the sample clock from one mainframe to another.

Sync Extender Input (Sync In)

This SMB connector is an ECL input used to drive the sync line on the backplane of the mainframe with a sync signal generated in another mainframe. The signal must be supplied from the "Sync Out" connector of an HP E1430A module in the driving mainframe.

Clock Extender Input (Clk In)

This SMB connector is an ECL input used to drive the sample clock line on the backplane of the mainframe with a clock signal generated in another mainframe. Normally the signal is supplied from the “Clk Out” connector of an HP E1430A module in the driving mainframe. This input can also be driven by an external ADC clock generator using ECL levels.

HP E1430A Front Panel

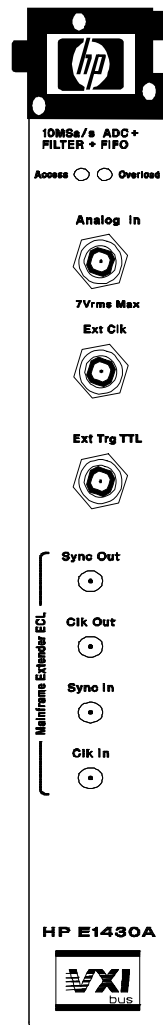

VXI Backplane Connections

Power Supplies and Ground

The HP E1430A conforms to the VME and VXI specifications for pin assignment. The current drawn from each supply is given in chapter 2, “Verifying Specifications.”

Data Transfer Bus

The HP E1430A conforms to the VME and VXI specifications for pin assignment and protocol. Only A16/D16 data transfers are supported. Thus the upper address and data bits are ignored.

DTB Arbitration Bus

The HP E1430A module is not capable of requesting bus control. Thus it does not use the Arbitration bus. To conform to the VME and VXI specifications, it passes the bus lines through.

Priority Interrupt Bus

The HP E1430A generates interrupts by applying a programmable mask to its status bits. The priority of the interrupt is determined by the interrupt priority setting in the control register.

Utility Bus

The VME specification provides a set of lines collectively called the utility bus. Of these lines, the HP E1430A only uses the SYSRESET* line.

Pulling the SYSRESET* line low (a hardware reset) has the same effect as setting the reset bit in the Control Register (a software reset), with two exceptions. The exceptions are:

- The Control Register is also reset.
- All logic arrays are reloaded.

Reloading the logic arrays enables the hardware reset to recover from power dropouts which may invalidate the logic setup.

Local Bus

The VXI specification includes a 12-wire local bus between adjacent module slots. Using the local bus, Hewlett-Packard has defined a standard byte-wide ECL protocol that transfers data from left to right at up to 100 Mbyte/s. The HP E1430A can be programmed to output its data using this high speed port instead of the VME data output register. The Data Port Control register determines which output port is used.

Trigger Lines

The VXI specification provides 8 TTL and 2 ECL trigger lines which can be used for module-specific signaling. When programmed in a multi-input configuration, the HP E1430A uses the ECL trigger lines, designating ECLTRG0 as the SYNC line and ECLTRG1 as the ADC sample clock (CLOCK). These lines can be extended to other mainframes using the SMB connectors on the front panel.

The CLOCK line is the master ADC clock for a synchronous system of multiple HP E1430A modules. Only one HP E1430A module in each mainframe is allowed to drive this line.

The SYNC line is used to send timing signals among HP E1430A modules in a multi-input system. Any module which drives this line must do so synchronously with CLOCK so that transitions on SYNC do not occur near the rising edge of CLOCK. This ensures that all modules with a synchronous state machine clocked on CLOCK will interpret SYNC in a consistent manner for each cycle of the state machine. SYNC is used for synchronizing, arming, and triggering signals between HP E1430A modules. The interpretation of the SYNC line is dependent on the states of the module described in the Measurement Loop section. The E1430A module is also capable of controlling the SYNC line synchronously via the Measurement Control Register.

9

Programming the HP E1430A with the C Interface Libraries

The C Interface Libraries for the HP E1430A are a set of functions that allow you to program the register-based HP E1430A at a higher level than register reads and writes. The libraries allow groups of HP E1430As to be set up and programmed as if they were one entity. The current state of each HP E1430A in a system is maintained in your host computer because you cannot read from many of the HP E1430A's registers you can write to. These states can be saved and restored. The libraries include routines to perform auto-ranging and autozeroing, routines to aid debugging and hardware diagnostic routines. In addition, there are low-level routines to allow direct register access, but with the added protection of bus error trapping.

The libraries are designed to work both in the Series 300 and Series 700 UNIX environment, in the Series 700 UNIX/MXI environment, and in the HP E1485A/B environment. *The library must be used in one environment or the other, but not both at the same time.* This restriction is necessary since the libraries maintain internal state information about the HP E1430A that could become corrupted if two sources are changing the HP E1430A's registers.

Getting Started

For instructions on how to install the C Interface Libraries, see Chapter 1, "Installing the HP E1430A."

Compiling and Linking Your Program

How you compile and link the libraries to your program depends on the operating environment.

HP-UX Environment

Here is an example of the linker line in the make file in an HP-UX environment:

```
cc -o<program name> <object files> /usr/e1430/lib/lib1430.a  
-lsicl -lc -lm
```

HP E1485A Environment

Here is an example of the linker line in the make file in an HP E1485A environment using the GNU compiler supplied with HP E1485A Programmer's Toolkit 2.0:

```
/usr/e1485/gcc/gcc -B/usr/gcc/gcc -nostdlib -d -r -N  
\<object files> /usr/e1485/lib/libspil.o -o <program name>
```

Here is an example of the linker line in older versions of the toolkit that are compiled with cc:

```
ld -dr -N -a archive /usr/e1485/lib/libspil.o <object files> \  
/usr/e1430/libd1430.a /usr/e1485/lib/libsrfa.a -o <program name>
```

Note

See the HP E1485A/B Programmer's Reference manual for more information on developing code in the HP E1485A environment.

Debugging

There are several levels of debugging aids provided with the libraries. First, you should check the return value of all functions. Usually, a non-zero value denotes an error.

The *e1430_print_errors* function can be called to enable/disable an error printing mechanism. If error printing is enabled, an error message will be printed by any function returning an error. If the libraries are used in a host computer environment, the errors are output to stdout (normally the console screen). If the libraries are used in the HP E1485A/B environment, the error messages will be output to a terminal connected to the RS-232-C port available on this module. It is normal while developing code to include a call to *e1430_print_errors* enabling error printing early in the code. Once the code has been fully debugged, you should remove this call.

There are functions for dumping individual registers or the complete state of a group of HP E1430As in an easy-to-read format. See “Debugging” under the C-libraries Quick Reference (by Category) following this section.

The function, *e1430_debug_level*, is used to print out a message each time a register write occurs to the HP E1430A. The message includes the register number and new contents being written. This function allows the detailed examination of a sequence of register writes as well as the contents of the HP E1430A registers at the bit level.

Diagnostics

The HP E1430A library comes with a set of diagnostic functions that test various sections of HP E1430A hardware and perform calibration. These functions can be called individually, or the entire diagnostic suite can be run. In addition, a standalone diagnostic program, *test1430*, is included with the software shipped with the HP E1430A.

Data Format

An HP E1430A can collect either real or complex data in 16-bit or 32-bit format. It can collect data into various blocksizes or in a continuous mode. This data can be transferred either through a register on the VXI backplane or over the local bus. Status information can be appended to each block of data indicating ADC overloads or ADC errors during the block.

Decimation Filter

The decimation filter provides bandpass filtering (low pass for baseband) and decimation capabilities. It is possible to program the filter to interleave output data from more than one stage of the filter, which is useful for octave type measurements.

Triggering

An HP E1430A can be triggered to collect data in a variety of ways. The trigger can be internally generated or can come from an external source. Multiple modules can be triggered synchronously. A variable pre and post trigger delay can be programmed for data collection. The slope and level of the trigger point on a signal can be selected. The source of the internal trigger can be either the output of the ADC or the magnitude of the complex output of the decimation filter. When in the magnitude triggering mode the trigger bandwidth out of the decimation filter can be selected independently of the bandwidth (span) of the data that is passed on out of the module.

Managing Multiple Mainframe Measurements

In a single mainframe measurement, the HP E1430A communicates with other HP E1430As through the TTLTRG lines. However, when using the VXI-MXI bus extender modules, the TTLTRG lines, which carry the group synchronization pulse and sample clock, are extended only in one direction. This unidirectional signal connection restricts the types of measurements you can make in a multiple mainframe environment.

You cannot perform the following types of multiple mainframe measurements:

- unequal pre-trigger delay settings between mainframes
- channel triggering by channels in Mainframe B
- lower spans or longer block sizes in Mainframe B
- different digital filter settling times between HP E1430A modules

Programming Specific Modules Contained in a Single Module Group

When using multiple HP E1430A modules with the ADC clocks synchronized, all modules share a common ADC clock and a common sync signal. Both of these are distributed across the VXI backplane. Since the SYNC line is used for multiple purposes (triggering, synchronizing local oscillators, and synchronizing decimation) it is important that all modules agree on the meaning of each SYNC line transition.

All modules in the mainframe which are programmed to use these shared resources must be placed in a single module group created by *e1430_create_module_group*. Since most of the library functions program all modules in a group simultaneously, they will normally have the same setup parameters.

One way to get different setups among the modules is to create additional groups, each of which contains a subset of the modules in the system. In the extreme, a sub-group of one module could be defined for each module in the system. There is a problem with this approach.

Many of the setup functions in the library check to see if a module is configured with the E1430_MULTI_SYNC_ON command. If it is, these functions use the SYNC line to program the modules in such a way as to maintain synchronization of the local oscillators and decimators. If any of these functions are called using one of the sub-group identifiers, the manipulation of the SYNC line is interpreted incorrectly by other modules which are not part of the sub-group. Thus none of these functions can be used for sub-group programming once the multi-sync mode has been set.

To establish different setups for these functions among the modules in a synchronous group, use the *e1430_write_register_image* command. This command will write directly to registers at individual logical addresses without using group IDs at all. This circumvents the check for multi_sync_on and allows setup without using the SYNC line. For example, block mode, data type, data precision, and zoom span can all be set up for an individual module by writing the appropriate value to register 12 (decimal). The registers are described in chapter 12, "VXI Registers".

Functions not listed in the following table may still be used for sub-groups even in systems with MULTI_SYNC_ON. For example, *e1430_set_analog_input* may be used to set up different ranges without having to resort to the lower level direct register writes. The direct register writes would work as well, removing the need to create the sub-groups at all.

The following functions should not be used for subgroups with MULTI_SYNC_ON:

e1430_abort_meas	e1430_set_data_size
e1430_arm_module	e1430_set_data_type
e1430_auto zero	e1430_set_decimation_bandwidth
e1430_diagnostics	e1430_set_decimation_filter
e1430_read_float32_data	e1430_set_decimation_output
e1430_read_raw_data	e1430_set_decimation_passtag
e1430_reset_dsp	e1430_set_decimation_states
e1430_reset_module	e1430_set_span_zoom
e1430_set_append_status	e1430_test_fifo_memory
e1430_set_blocksize	e1430_test_interrupts
e1430_set_center_frequency	e1430_test_meas_control
e1430_set_data_format	e1430_test_trigger
e1430_set_data_mode	e1430_trigger_module

C Libraries Quick Reference (by Category)

Initialization

A user program must first initialize the I/O driver and set up at least one module group.
An HP E1430A can be reset and the timeout for I/O operations set optionally.

Function	Description	Page number
e1430_init_io_driver	Initialize I/O driver	10- 18
e1430_create_module_group	Create a group of HP E1430A modules	10- 5
e1430_delete_module_group	Delete a group of HP E1430A modules	10- 5
e1430_delete_all_module_groups	Delete all groups of HP E1430A modules	10- 5
e1430_get_timeout	Get value of timeout for I/O operations	10- 67
e1430_set_timeout	Set value of timeout for I/O operations	10- 67

Configuring the Analog Inputs

Function	Description	Page number
e1430_auto zero	Null out input DC offset	10-4
e1430_auto_range	Set range at level to avoid ADC overload	10-4
e1430_set_analog_input	Set all analog setup parameters	10-26
e1430_set_range	Set range of all HP E1430As in a group	10-62
e1430_get_range	Get current range of all HP E1430As in a group	10-62
e1430_set_range-la	Set range of HP E1430A at a logical address	10-62
e1430_get_range_la	Get range of HP E1430A at a logical address	10-62
e1430_set_anti_alias_filter	Include/bypass input anti-alias filter	10-28
e1430_get_anti_alias_filter	Get current state of anti-alias filter	10-28
e1430_set_coupling	Set input coupling to AC or DC	10-36
e1430_get_coupling	Get current state of input coupling	10-36
e1430_set_input_high	Set source of input signal to ADC	10-54
e1430_get_input_high	Get current source of input signal	10-54
e1430_set_input_low	Set input connector shield to float or ground	10-54
e1430_get_input_low	Get state of input connector shield	10-54
e1430_get_input_offset	Get the value of the input offset DAC	10-56
e1430_set_input_offset	Set the value of the input offset DAC	10-56

Data Format

Function	Description	Page number
e1430_set_data_format	Set all data format parameters except data port	10-37
e1430_set_data_port	Set data port to VME or Local Bus	10-40
e1430_get_data_port	Get current data port	10-40
e1430_set_lbus_mode	Set the transmission mode of the Local Bus	10-59
e1430_get_lbus_mode	Get the transmission mode of the Local Bus	10-59
e1430_set_data_mode	Set data collection to block or continuous mode	10-39
e1430_get_data_mode	Get current data collection mode	10-39
e1430_set_append_status	Enable/disable appending status onto data	10-29
e1430_get_append_status	Get current state of append status switch	10-29
e1430_set_data_type	Set data type to real or complex	10-43
e1430_get_data_type	Get current value of data type	10-43
e1430_get_data_reread	Get current reread state	10-41
e1430_set_data_reread	Set FIFO to continuous reread of block	10-41
e1430_set_data_size	Set data size to 16 or 32 bits	10-42
e1430_get_data_size	Get current value of data size	10-42
e1430_set_blocksize	Set blocksize	10-30
e1430_get_blocksize	Get current blocksize	10-30

Trigger

Function	Description	Page number
e1430_set_trigger_mode	Set all trigger setup parameters	10-72
e1430_set_trigger_source	Set source of trigger	10-76
e1430_get_trigger_source	Get current source of trigger	10-76
e1430_set_trigger_slope	Set slope of trigger	10-75
e1430_get_trigger_slope	Get current slope of trigger	10-75
e1430_set_trigger_level_adc	Set trigger level for ADC triggering	10-70
e1430_get_trigger_level_adc	Get current ADC triggering level	10-70
e1430_set_trigger_level_mag	Set trigger level for magnitude triggering	10-71
e1430_get_trigger_level_mag	Get current magnitude triggering level	10-71
e1430_set_trigger_delay	Set trigger delay	10-68
e1430_get_trigger_delay	Get current trigger delay	10-68
e1430_get_trigger_bandwidth	Get current trigger bandwidth	10-44
e1430_get_trigger_phase	Get current trigger phase	10-17

Decimation Filter

Function	Description	Page number
e1430_set_decimation_filter	Set all decimation filter parameters	10-46
e1430_set_decimation_bandwidth	Set data and trigger bandwidths and decimation	10-44
e1430_get_decimation_bandwidth	Get current data bandwidth (span)	10-44
e1430_set_decimation_state	Enable/disable extra X2 decimation	10-52
e1430_get_decimation_state	Get current state of extra decimation	10-52
e1430_set_decimation_output	Set filter output as one pass or multi-pass	10-49
e1430_get_decimation_output	Get current state of output	10-49
e1430_set_decimation_passtag	Set position of tag on multi-pass data	10-50
e1430_get_decimation_passtag	Get position of tage on data	10-50

Measurement

Function	Description	Page number
e1430_abort_meas	Move HP E1430A to IDLE state	10-2
e1430_arm_module	Move HP E1430A to ARM state	10-3
e1430_get_center_frequency	Get current center frequency	10-31
e1430_get_span	Get span	10-65
e1430_reset_module	Reset all HP E1430As in a group	10-23
e1430_reset_dsp	Reset local oscillator phase and decimation filters	10-21
e1430_reset_lbus	Reset local bus on all HP E1430As in a group	10-22
e1430_set_center_frequency	Set center frequency	10-31
e1430_trigger_module	Trigger HP E1430A programatically	10-78
e1430_set_span_zoom	Set center frequency, span, and zoom at one time	10-65

Reading Data

Function	Description	Page number
e1430_read_raw_data	Read raw data from HP E1430A	10-19
e1430_get_scale_la	Get data scaling factor of HP E1430A	10-19
e1430_read_float32_data	Read scaled float data from HP E1430A	10-19
e1430_get_fifo_block_data_size	Return size in bytes of block of data	10-13
e1430_get_fifo_size	Return size in bytes of FIFO	10-13
e1430_get_fifo_data_point_size	Return size in bytes of one sample	10-13
e1430_get_fifo_max_blocksize	Return size in samples of maximum block	10-13

Timing

Function	Description	Page number
e1430_set_clock_mode	Set all trigger setup parameters	10-34
e1430_set_clock_master_mode	Enable an HP E1430A to drive VXI clock line	10-32
e1430_set_adc_clock	Set ADC clock source	10-25
e1430_get_adc_clock	Get current value of ADC clock source	10-25
e1430_set_dsp_clock	Set DSP clock source	10-53
e1430_get_dsp_clock	Get current value of DSP clock source	10-53
e1430_set_multi_sync	Set multi-module synchronization	10-60
e1430_get_multi_sync	Get current multi-module sync state	10-60
e1430_get_sample_clock_freq_la	Get sample clock frequency	10-64
e1430_set_sample_clock_freq_la	Set external sample clock frequency	10-64

Interrupts

Function	Description	Page number
e1430_set_interrupt	Sets all interrupt parameters	10-57
e1430_set_interrupt_priority	Set interrupt priority	10-57
e1430_get_interrupt_priority	Get current interrupt priority	10-57
e1430_set_interrupt_mask	Set interrupt mask	10-57
e1430_get_interrupt_mask	Get current interrupt mask	10-57

Register Read/Write

Function	Description	Page number
E1430_TRY E1430_RECOVER	Bracket code with these to trap bus errors	*
e1430_get_register_address	Get memory mapped address of HP E1430A register	10-14
e1430_set_try_recover	Turn TRY-RECOVER mechanism on or off	10-14
e1430_write_register	Register write to all HP E1430As in group	10-79
e1430_write_register_card	Register write to one HP E1430A only	10-79
e1430_write_register_image	Register write to one HP E1430A and image	10-79
e1430_read_register_card	Register read of one HP E1430A	10-79
e1430_read_register_image	Register read of internal image of HP E1430A	10-79

*These macro definitions are included to be able to trap bus errors when doing direct accesses on a register.

Diagnostics and Calibration

Function	Description	Page number
e1430_diagnostics	Perform all HP E1430A diagnostics	10-9
e1430_test_logical_address	Verify decoding of logical addresses	10-9
e1430_test_register_access	Verify register access	10-9
e1430_test_meas_control	Verify measurement loop	10-9
e1430_test_timing_setup	Verify ADC and DSP clock sources	10-9
e1430_test_fifo_memory	Verify FIFO memory	10-9
e1430_test_data_collection	Verify data collection modes	10-9
e1430_test_trigger	Verifies proper operation of trigger modes	10- 9
e1430_test_interrupts	Verify interrupt modes	10-9

Debugging

Function	Description	Page number
e1430_display_module_state	Dump HP E1430A state in easy to read format	10-7
e1430_display_register	Dump contents of an HP E1430A register	10-7
e1430_get_module_state	Return internal HP E1430A state	10-7
e1430_print_errors	Enable/disable function error printout	10-7
e1430_get_error_string	Points to most recent error returned	10- 7
e1430_debug_level	Enable/disable register write printout	10-7

Post Processing Data

Function	Description	Page number
e1430_get_filter	Filter time domain data	10- 11
e1430_get_resample	Filter and resample time domain data	10-15

C Libraries Quick Reference (Alphabetical)

Function	Description	Page number
e1430_abort_meas	Move HP E1430A to IDLE state	10-2
e1430_arm_module	Move HP E1430A to ARM state	10-3
e1430_auto_zero	Null out input DC offset	10-4
e1430_auto_range	Set range at level to avoid ADC overload	10-4
e1430_create_module_group	Create a group of HP E1430A modules	10- 5
e1430_debug_level	Enable/disable register write printout	10-7
e1430_delete_all_module_groups	Delete all groups of HP E1430A modules	10- 5
e1430_delete_module_group	Delete a group of HP E1430A modules	10- 5
e1430_diagnostics	Perform all HP E1430A diagnostics	10-9
e1430_display_module_state	Dump HP E1430A state in easy to read format	10-7
e1430_display_register	Dump contents of an HP E1430A register	10-7
e1430_get_adc_clock	Get current value of ADC clock source	10-25
e1430_get_anti_alias_filter	Get current state of anti-alias filter	10-28
e1430_get_append_status	Get current state of append status switch	10-29
e1430_get_blocksize	Get current blocksize	10-30
e1430_get_center_frequency	Get current center frequency	10-31
e1430_get_coupling	Get current state of input coupling	10-36
e1430_get_data_mode	Get current data collection mode	10-39
e1430_get_data_port	Get current data port	10-40
e1430_get_data_reread	Get current reread state	10-41
e1430_get_data_size	Get current value of data size	10-42
e1430_get_data_type	Get current value of data type	10-43
e1430_get_decimation_bandwidth	Get current data bandwidth (span)	10-44
e1430_get_decimation_output	Get current state of output	10-49
e1430_get_decimation_passtag	Get position of tage on data	10-50
e1430_get_decimation_state	Get current state of extra decimation	10-52
e1430_get_dsp_clock	Get current value of DSP clock source	10-53
e1430_get_error_string	Points to most recent error returned	10- 7
e1430_get_fifo_block_data_size	Return size in bytes of block of data	10-13
e1430_get_fifo_data_point_size	Return size in bytes of one sample	10-13
e1430_get_fifo_max_blocksize	Return size in samples of maximum block	10-13
e1430_get_fifo_size	Return size in bytes of FIFO	10-13
e1430_get_filter	Filter time domain data	10- 11

Function	Description	Page Number
e1430_get_input_high	Get current source of input signal	10-54
e1430_get_input_low	Get state of input connector shield	10-54
e1430_get_input_offset	Get the value of the input offset DAC	10-56
e1430_get_interrupt_mask	Get current interrupt mask	10-57
e1430_get_interrupt_priority	Get current interrupt priority	10-57
e1430_get_lbus_mode	Get the transmission mode of the Local Bus	10-59
e1430_get_module_state	Return internal HP E1430A state	10-7
e1430_get_multi_sync	Get current multi-module sync state	10-60
e1430_get_range	Get current range of all HP E1430As in a group	10-62
e1430_get_range_la	Get range of HP E1430A at a logical address	10-62
e1430_get_register_address	Get memory mapped address of HP E1430A register	10-14
e1430_get_resample	Filter and resample time domain data	10-15
e1430_get_sample_clock_freq_la	Get sample clock frequency	10-64
e1430_get_scale_la	Get data scaling factor of HP E1430A	10-19
e1430_get_span	Get span	10-65
e1430_get_timeout	Get value of timeout for I/O operations	10-67
e1430_get_trigger_bandwidth	Get current trigger bandwidth	10-44
e1430_get_trigger_delay	Get current trigger delay	10-68
e1430_get_trigger_level_adc	Get current ADC triggering level	10-70
e1430_get_trigger_level_mag	Get current magnitude triggering level	10-71
e1430_get_trigger_phase	Get current trigger phase	10-17
e1430_get_trigger_slope	Get current slope of trigger	10-75
e1430_get_trigger_source	Get current source of trigger	10-76
e1430_init_io_driver	Initialize I/O driver	10-18
e1430_print_errors	Enable/disable function error printout	10-7
e1430_read_float32_data	Read scaled float data from HP E1430A	10-19
e1430_read_raw_data	Read raw data from HP E1430A	10-19
e1430_read_register_card	Register read of one HP E1430A	10-79
e1430_read_register_image	Register read of internal image of HP E1430A	10-79
e1430_reset_dsp	Reset local oscillator phase and decimation filters	10-21
e1430_reset_lbus	Reset local bus on all HP E1430As in a group	10-22
e1430_reset_module	Reset all HP E1430As in a group	10-23
e1430_set_adc_clock	Set ADC clock source	10-25
e1430_set_analog_input	Set all analog setup parameters	10-26
e1430_set_anti_alias_filter	Include/bypass input anti-alias filter	10-28
e1430_set_append_status	Enable/disable appending status onto data	10-29

HP E1430A User's Guide
C Libraries Quick Reference (Alphabetical)

Function	Description	Page Number
e1430_set_blocksize	Set blocksize	10-30
e1430_set_center_frequency	Set center frequency	10-31
e1430_set_clock_master_mode	Enable an HP E1430A to drive VXI clock line	10-32
e1430_set_clock_mode	Set all trigger setup parameters	10-34
e1430_set_coupling	Set input coupling to AC or DC	10-36
e1430_set_data_format	Set all data format parameters except data port	10-37
e1430_set_data_mode	Set data collection to block or continuous mode	10-39
e1430_set_data_port	Set data port to VME or Local Bus	10-40
e1430_set_data_reread	Set FIFO to continuous reread of block	10-41
e1430_set_data_size	Set data size to 16 or 32 bits	10-42
e1430_set_data_type	Set data type to real or complex	10-43
e1430_set_decimation_bandwidth	Set data and trigger bandwidths and decimation	10-44
e1430_set_decimation_filter	Set all decimation filter parameters	10-46
e1430_set_decimation_output	Set filter output as one pass or multi-pass	10-49
e1430_set_decimation_passtag	Set position of tag on multi-pass data	10-50
e1430_set_decimation_state	Enable/disable extra X2 decimation	10-52
e1430_set_dsp_clock	Set DSP clock source	10-53
e1430_set_input_high	Set source of input signal to ADC	10-54
e1430_set_input_low	Set input connector shield to float or ground	10-54
e1430_set_input_offset	Set the value of the input offset DAC	10-56
e1430_set_interrupt	Sets all interrupt parameters	10-57
e1430_set_interrupt_mask	Set interrupt mask	10-57
e1430_set_interrupt_priority	Set interrupt priority	10-57
e1430_set_lbus_mode	Set the transmission mode of the Local Bus	10-59
e1430_set_multi_sync	Set multi-module synchronization	10-60
e1430_set_range	Set range of all HP E1430As in a group	10-62
e1430_set_range-la	Set range of HP E1430A at a logical address	10-62
e1430_set_sample_clock_freq_la	Set external sample clock frequency	10-64
e1430_set_span_zoom	Set center frequency, span, and zoom at one time	10-65
e1430_set_timeout	Set value of timeout for I/O operations	10-67
e1430_set_trigger_delay	Set trigger delay	10-68
e1430_set_trigger_level_adc	Set trigger level for ADC triggering	10-70
e1430_set_trigger_level_mag	Set trigger level for magnitude triggering	10-71
e1430_set_trigger_mode	Set all trigger setup parameters	10-72
e1430_set_trigger_slope	Set slope of trigger	10-75
e1430_set_trigger_source	Set source of trigger	10-76

Function	Description	Page Number
e1430_set_try_recover	Turn TRY-RECOVER mechanism on or off	10-14
e1430_test_data_collection	Verify data collection modes	10-9
e1430_test_fifo_memory	Verify FIFO memory	10-9
e1430_test_interrupts	Verify interrupt modes	10-9
e1430_test_logical_address	Verify decoding of logical addresses	10-9
e1430_test_meas_control	Verify measurement loop	10-9
e1430_test_register_access	Verify register access	10-9
e1430_test_timing_setup	Verify ADC and DSP clock sources	10-9
e1430_test_trigger	Verifies proper operation of trigger modes	10-9
e1430_trigger_module	Trigger HP E1430A programatically	10-78
E1430_TRY E1430_RECOVER	Bracket code with these to trap bus errors	*
e1430_write_register	Register write to all HP E1430As in group	10-79
e1430_write_register_card	Register write to one HP E1430A only	10-79
e1430_write_register_image	Register write to one HP E1430A and image	10-79

*These macro definitions are included to be able to trap bus errors when doing direct accesses on a register.

10

C Interface Library Support Reference

e1430_abort_meas

Abort measurement

SYNOPSIS

```
#include "e1430.h"
```

```
SHORTSIZ16 e1430_abort_meas(groupID)  
SHORTSIZ16 groupID;
```

DESCRIPTION

E1430_abort_meas places all HP E1430As in the group into the IDLE state.

GroupID is the group ID of a single HP E1430A or group of HP E1430As that was obtained by a call to *e1430_create_module_group*.

RETURN VALUE

Upon successful completion a value of 0 is returned. Otherwise an error will be returned. The error, ERR1430_NO_GROUP, is returned if an illegal value of the *groupID* parameter is used (i.e. one that was not obtained by a call to *e1430_create_module_group(E1430)*).

SEE ALSO

e1430_create_module_group(E1430), *e1430_set_timeout(E1430)*.

e1430_arm_module

Arm HP E1430A to take a measurement

SYNOPSIS

```
#include "e1430.h"
```

```
SHORTSIZ16 e1430_arm_module(groupID)  
SHORTSIZ16 groupID;
```

DESCRIPTION

E1430_arm_module moves all HP E1430As in a synchronous module group into the IDLE state. After all HP E1430As in the group are in the IDLE state, they are moved into the ARM state. A synchronous module group is one in which all HP E1430As in the group have been placed in the multi-sync mode using the *e1430_set_multi_sync* function, and one HP E1430A in the group has been designated clock master using the *e1430_set_clock_master_mode* function.

Note:

e1430_arm_module works only with single HP E1430As or synchronous groups of HP E1430As. To arm multiple HP E1430As not in a synchronous group, create a groupID for each HP E1430A in addition to the groupID for the collection of HP E1430As. *E1430_arm_module* is then called for each groupID in the non-synchronous collection.

GroupID is the group ID of a single HP E1430A or group of HP E1430As that was obtained by a call to *e1430_create_module_group*.

RETURN VALUE

Upon successful completion a value of 0 is returned, otherwise an error will be returned. The error, ERR1430_NO_GROUP, is returned if an illegal value of the *groupID* parameter is used (i.e. one that was not obtained by a call to *e1430_create_module_group(E1430)*). If there is a time-out, there are two possible errors. ERR1430_WAIT_SYNC_TIMEOUT will be returned if an attempt is made to place the SYNC line in a certain state and it doesn't happen. ERR1430_ARM_TIMEOUT will be returned if a time-out occurs waiting for all HP E1430As to go into the ARM state. ERR1430_NO_MASTER is returned if there is more than one HP E1430A in this group and none has been designated clock master. ERR1430_NOT_SYNCHRONOUS_GROUP is returned if all modules in the group are not in the multi-sync mode.

SEE ALSO

e1430_create_module_group(E1430), *e1430_set_timeout(E1430)*,
e1430_set_multi_sync(E1430), *e1430_set_clock_master_la(E1430)*.

e1430_auto_range **e1430_auto_zero**

Perform auto zero or auto range

SYNOPSIS

```
#include "e1430.h"
```

```
SHORTSIZ16 e1430_auto_range(groupID, time);  
SHORTSIZ16 groupID;  
FLOATSIZ64 time;
```

```
SHORTSIZ16 e1430_auto_zero(groupID);  
SHORTSIZ16 groupID;
```

DESCRIPTION

E1430_auto_zero will set the input offset DAC of all HP E1430As in a group to a value that will null out the offset of the input amplifier of the ADC. It will do this by grounding the amplifier and going through all ranges, nulling the offset voltage. Each of these values of offset voltage are stored in the internal state structure for each HP E1430A. Whenever a future range change occurs, the offset value for that range is placed in the offset DAC to zero the input offset.

Note:

A waiting period of 20 seconds is required after *e1430_auto_zero* to allow the ADC calibration to settle to its specified accuracy.

The *e1430_auto_zero* function can cause disruption of data in the Local Bus pipeline, if the Local Bus is in use. The Local Bus must be reset after calling this function. See reset instructions under *e1430_reset_lbus()*.

E1430_auto_range will set the range of all HP E1430As in a group to the lowest value that will not cause an ADC overload to occur. The algorithm will start at the lowest range and move up until there is no ADC overload.

GroupID is the group ID of a single HP E1430A or a group of HP E1430As that was obtained by a call to *e1430_create_module_group*.

Time is the time in seconds to take data at each range to insure that an overload is detected. Setting this parameter to 0.0 will result in this time being set according to an algorithm that depends on blocksize, decimation level, etc.

RETURN VALUE

Upon successful completion a value of 0 is returned by all functions. Otherwise an error will be returned. The error, `ERR_NO_GROUP`, is returned if an illegal value of the *groupID* parameter is used (i.e. one that was not obtained by a call to *e1430_create_module_group(E1430)*).

SEE ALSO

`e1430_create_module_group(E1430)`.

e1430_create_module_group
e1430_delete_module_group
e1430_delete_all_module_groups

Create and destroy module groups

SYNOPSIS

```
#include "e1430.h"

SHORTSIZ16 e1430_create_module_group(numMods, laArray);
SHORTSIZ16 numMods;
SHORTSIZ16 *laArray;

SHORTSIZ16 e1430_delete_module_group(groupID);
SHORTSIZ16 groupID;

SHORTSIZ16 e1430_delete_all_module_groups();
```

DESCRIPTION

E1430_create_module_group creates and initializes a module group. The concept of a module group allows the user to issue commands to several HP E1430A modules at once, thus simplifying system setup. This function returns a 16-bit integer, *groupID*, which is then used to reference the module group in most other functions in this library. Modules included in a group have an internal data structure that keeps track of the state of the write only registers on an HP E1430A and other information. It is possible to have overlapping module groups. The state of an individual HP E1430A that is in more than one module group will be determined by the most recent operation performed on one of its module groups. The first time a module is added to any module group, *e1430_reset_module_group* should be called to set these modules to their power-up state. A waiting period of 20 seconds is required after reset to allow the ADC calibration to settle to specified accuracy.

E1430_delete_module_group "ungroups" a module group, releasing the memory associated with the group's internal data structure. The state of an individual module is maintained, even if it is referenced by no other module group. An individual module "ungrouped" by this function that does not belong to any existing group will not be reset if included in another group by a subsequent call to *e1430_create_module_group*; it will retain its old state at the time of the *e1430_delete_module_group* call.

Note:

It is good practice to use *e1430_reset_module()* to reset the group before deleting it. This will clear any HP E1430As that are acting as clock masters, driving the VXI backplane with their internal clocks and SYNC signals.

E1430_delete_all_module_groups deletes all module groups, freeing the memory for all internal data structures. Individual module states are not remembered after this call, and any subsequent call to *e1430_create_module_group* will reset all HP E1430As in the group.

LaArray is a pointer to an array of logical addresses of HP E1430As to be included into a logical group.

NumMods is the number of logical addresses in the array pointed to by *laArray*.

GroupID is the group ID of a single HP E1430A or group of HP E1430As that was returned by a call to *e1430_create_module_group*.

RETURN VALUE

E1430_create_module_group returns a positive integer, *group ID*, when successful. It will return 0 if unsuccessful. These *groupIDs* are greater than 255 to be able to distinguish them from logical addresses when returning error messages. A call to *e1430_print_errors* before the unsuccessful call to *e1430_create_module_group* will cause the reason for an error to be output to the screen.

All other functions return a value of 0 when successful. Otherwise an error will be returned. The error, ERR1430_NO_GROUP, is returned if an illegal value of the *groupID* parameter is used (i.e. one that was not obtained by a call to *e1430_create_module_group(E1430)*).

SEE ALSO

e1430_create_module_group(E1430), e1430_print_errors(E1430).

e1430_debug_level
e1430_display_module_state
e1430_display_register
e1430_get_error_string
e1430_get_module_state
e1430_print_errors

Debugging aids

SYNOPSIS

```
#include "e1430.h"

SHORTSIZ16 e1430_debug_level(SHORTSIZ16 level);
SHORTSIZ16 level;

SHORTSIZ16 e1430_display_module_state(groupID);
SHORTSIZ16 groupID;

SHORTSIZ16 e1430_display_register(groupID, offset, image);
SHORTSIZ16 groupID;
SHORTSIZ16 offset;
SHORTSIZ16 image;

char *e1430_get_error_string();

SHORTSIZ16 e1430_get_module_state(la, statePtr);
SHORTSIZ16 la;
aE1430State *statePtr;

SHORTSIZ16 e1430_print_errors(enable);
SHORTSIZ16 enable;
```

DESCRIPTION

E1430_debug_level will enable or disable printing of actual register writes to an HP E1430A on the standard output using printf. Calling the function with *level* non-zero will enable printing of information about each register write made by the HP E1430A library. Calling it with *level* equal zero will disable the printing of this information.

E1430_display_module_state will use printf to dump the current state of all HP E1430As in *groupID* in an easy to read format.

E1430_display_register will use printf to dump the current state of a register. Depending on what the value of *image* is will dump the value of the register image in memory or the actual value read from the HP E1430A's register set, if it is a readable register.

E1430_get_error_string will return the pointer to a string describing the most recent error returned by any function in the library that returns error values.

E1430_get_module_state will return the state of a particular HP E1430A into the structure, aE1430State, which is defined in e1430.h.

E1430_print_errors enables/disables the printing of error messages to the standard output using printf, when any function returns an error. When called with the *enable* parameter non-zero, the printing is enabled. Calling with a value of zero disables the error message printing.

GroupID is the group ID of a single HP E1430A or group of HP E1430As that was obtained by a call to *e1430_create_module_group*.

La is the logical address of a single HP E1430A.

StatePtr is a pointer to a memory location in which to return the current state of an HP E1430A. It is a pointer to an aE1430State structure. The programmer must allocate this memory and pass the pointer to it. The aE1430State structure is defined in e1430.h.

Offset is the register offset of the VXI register of interest.

Image selects whether the register image (maintained in memory) or the actual register value is displayed. E1430_IMAGE_REGISTER selects the internal image, while E1430_CARD_REGISTER selects the value read directly from the HP E1430A, if it is a readable register.

RETURN VALUE

Upon successful completion a value of 0 is returned by all functions. Otherwise an error will be returned. The error, ERR1430_NO_GROUP, is returned if an illegal value of the *groupID* parameter is used (i.e. one that was not obtained by a call to *e1430_create_module_group(E1430)*). If there is no HP E1430A at the logical address given by the *la* parameter, the error, ERR1430_NO_MOD_AT_LA will be returned.

SEE ALSO

e1430_create_module_group(E1430).

e1430_diagnostics
e1430_test_data_collection
e1430_test_fifo_memory
e1430_test_interrupts
e1430_test_logical_address
e1430_test_meas_control
e1430_test_register_access
e1430_test_timing_setup
e1430_test_trigger

Hardware diagnostics

SYNOPSIS

```
#include "e1430.h"

SHORTSIZ16 e1430_diagnostics(la, flag);
SHORTSIZ16 la;
SHORTSIZ16 flag;

SHORTSIZ16 e1430_test_data_collection(la);
SHORTSIZ16 la;

SHORTSIZ16 e1430_test_fifo_memory(la);
SHORTSIZ16 la;

SHORTSIZ16 e1430_test_interrupts(la);
SHORTSIZ16 la;

SHORTSIZ16 e1430_test_logical_address(la);
SHORTSIZ16 la;

SHORTSIZ16 e1430_test_meas_control(la);
SHORTSIZ16 la;

SHORTSIZ16 e1430_test_register_access(la);
SHORTSIZ16 la;

SHORTSIZ16 e1430_test_timing_setup(la);
SHORTSIZ16 la;

SHORTSIZ16 e1430_test_trigger(la);
SHORTSIZ16 la;
```

DESCRIPTION

E1430_diagnostics is a function that calls all of the other diagnostic functions. It will perform a reset on the module under test and will leave it in the default state after the test. After the diagnostics are run, the modules will have to run 20 seconds for the ADC calibration to return to specified accuracy.

E1430_test_data_collection checks the ability of the HP E1430A to collect data and output the results with the correct data type.

E1430_test_fifo_memory exercises the FIFO memory with a sine wave and verifies the response.

E1430_test_interrupts exercises the interrupt hardware.

E1430_test_logical_address verifies logical address decoding and proper response to D8, D16 and D32 bus operations as well as A16, A24 and A32 addressing modes.

Note:

This test should only be run in a system with one HP E1430A, since it tests other logical addresses to see if an HP E1430A will illegally respond to a logical address other than its own. It will return errors in a multiple HP E1430A system.

E1430_test_meas_control verifies proper operation of the measurement loop.

E1430_test_register_access verifies proper access to all of the registers of the HP E1430A.

E1430_test_timing_setup verifies proper operation of the ADC and DSP clocks.

E1430_test_trigger verifies proper operation of the trigger modes.

La is the logical address of a single HP E1430A.

Flag determines if the logical address test and the FIFO memory test diagnostic are run. The logical address test should only be run in a system that has one HP E1430A, otherwise it will return errors. The *flag* parameter can be zero, which means neither of these two tests are run. It can also be either MEM_TEST_FLAG, REG_ACCESS_TEST_FLAG, or both of these ORed together.

RETURN VALUE

Upon successful completion a value of 0 is returned by all functions. If an error is encountered, a positive error number is returned.

e1430_get_filter_data

Take the input buffer data, filter it and return new data in the output buffer.

SYNOPSIS

```
#include "e1430.h"

SHORTSIZ16 get_filt_data(*in_buffer,out_buffer,*rec,clock,size,filter,bw_num)

FLOATSIZ32 *in_buffer
FLOATSIZ32 *out_buffer
FLOATSIZ32 *rec
SHORTSIZ16 clock
LONGSIZ32 size
SHORTSIZ16 filter
SHORTSIZ16 bw_num
```

DESCRIPTION

e1430_get_filter_data returns a block of floating point data that has been filtered with respect to the calling parameters. The scaling of the resampled data is the same as the scaling of the original raw data. Both the *in_buffer* and the *out_buffer* represent REAL data.

This function is faster than the resampling function, and in the block mode has a startup transient. The ratio of output points to input points is 1. In the continuous mode the transient is eliminated if the system is in real time and the user keeps the **rec* registers updated correctly.

This function compensates for the analog and digital filters of the HP E1430A and provides incorrect results if the analog filter is not used, or if incorrect information about how the data was collected is passed on to the function. When the HP E1430A digital filters are used, (*deci_bw 0*) proper operation of the function requires that the final 2x decimation be turned on by using the *e1430_set_decimation_state* function.

in_buffer is the buffer containing the data to be filtered. The buffer size is indicated by the *size* parameter in the parameter list.

out_buffer is the buffer containing the data that has been filtered. This buffer is sized and allocated by the calling program.

rec is a fixed buffer of 12 points (0 to 11) which represents the data in the compensation filters. For single HP E1430A systems, this buffer is zeroed in the block mode and contains previous good data in the continuous mode. If multiple HP E1430A's are used in the continuous mode the user must provide interim storage between calls to different HP E1430A's.

clock is a value which depends on the value of the HP E1430A clock. This value can be found by checking the status register or using the *status long* command in the demo program. 0 = 10 MHz and 1 = 10.24 MHz.

size is the size of the *in_buffer*, also referred to as the blocksize parameter for the HP E1430A. It is a power of 2 starting at 4 for real 16 bit data.

HP E1430A User's Guide
e1430_get_filter_data

filter is an integer which indicates which kind of filtering is taking place. 0 = "gauss" = gaussian filtering, 1 = "flat" = linear phase filtering.

0 provides a Gaussian impulse response for a non-overshooting step response. Frequency response is linear phase Gaussian with 3dB bandwidth equal to the input block sample rate/10.

1 provides flat linear phase frequency response to .35 times the input block sample rate. This preserves the time domain shape of any signal constrained to this bandwidth. See the following example.

A/D clock = 10.00 MHz; bw_num = 3
3dB Gaussian BW = 250 kHz
3dB Flat BW = 937 kHz

bw_num is an integer which is the value that the decimation of the HP E1430A was at when the data was taken. It is a number between 0 and 25. Refer to the level parameter in *e1430_set_decimation_filter* for an explanation of the *bw_num*.

RETURN VALUE

Upon successful completion the number 0 will be returned, otherwise an error is returned.

SEE ALSO

e1430_set_decimation_state(E1430), e1430_set_decimation_bandwidth(E1430)

e1430_get_fifo_block_data_size
e1430_get_fifo_data_point_size
e1430_get_fifo_max_blocksize
e1430_get_fifo_size

Get sizes in FIFO memory

SYNOPSIS

```
#include "e1430.h"

SHORTSIZ16 e1430_get_fifo_block_data_size(la, sizePtr);
SHORTSIZ16 la;
LONGSIZ32 *sizePtr;

SHORTSIZ16 e1430_get_fifo_data_point_size(la, sizePtr);
SHORTSIZ16 la;
LONGSIZ32 *sizePtr;

SHORTSIZ16 e1430_get_fifo_max_blocksize(la, sizePtr);
SHORTSIZ16 la;
LONGSIZ32 *sizePtr;

SHORTSIZ16 e1430_get_fifo_size(la, sizePtr);
SHORTSIZ16 la;
LONGSIZ32 *sizePtr;
```

DESCRIPTION

E1430_get_fifo_size returns the total size of the FIFO.

E1430_get_fifo_data_point_size returns the size of one data sample in the FIFO for the currently selected data type and precision.

E1430_get_fifo_block_data_size returns the size of one block of data in the FIFO for the currently selected data type, precision and blocksize.

E1430_get_fifo_max_blocksize returns the maximum blocksize that can be stored in the FIFO with the currently selected data type and precision.

La is the logical address of a single HP E1430A.

SizePtr is a pointer to a memory location in which to return the current value of a particular size parameter for an HP E1430A.

RETURN VALUE

Upon successful completion a value of 0 is returned by all functions. Otherwise an error will be returned. If there is no HP E1430A at the logical address given by the *la* parameter, the error, ERR1430_NO_MOD_AT_LA will be returned.

e1430_get_register_address **e1430_set_try_recover**

Get the address of HP E1430A register

SYNOPSIS

```
#include "e1430.h"

volatile SHORTSIZ16 *e1430_get_register_address(la, reg);
SHORTSIZ16 la;
SHORTSIZ16 reg;

void e1430_set_try_recover(state);
SHORTSIZ16 state;
```

DESCRIPTION

e1430_get_register_address will return the address of a register on a single HP E1430A located at logical address, *la*. This address can be used to directly access the register in question.

Note:

Bus errors that occur when accessing a register from an address returned by this function are not trapped; so extreme care must be exercised when using the address returned. It is customary to use the `E1430A_TRY` and `E1430_RECOVER` macros defined in `e1430.h` to bracket any code which directly addresses registers.

The TRY-RECOVER mechanism allows trapping of bus errors in code that occurs between the `E1430A_TRY` and the `E1430_RECOVER` macros. If a bus error occurs in the code between these two macros, control immediately passes to the line after the `E1430_RECOVER` macro. Note that the `E1430_RECOVER` macro will require a pair of brackets after it if more than one line is meant to be executed in the recover block.

Typical usage of *e1430_get_register_address* is:

```
SHORTSIZ16 *addr, la, buff[1024];
addr = e1430_get_register_address(la, E1430_HP_SEND_DATA_REG);
E1430_TRY
for(i=0; i, i++) buff[i] = *addr;
E1430_RECOVER
{printf ("Bus error while reading data at word %hd\n", i); exit(-1);}
```

e1430_set_try_recover can enable/disable the TRY-RECOVER mechanism in all of the library excluding the diagnostics and calibration routines. Setting the *state* parameter to non-zero enables the TRY-RECOVER mechanism, while zero disables it. The default condition is to have it enabled. This function is provided to allow the user to have provide their own global TRY-RECOVER mechanism, since each invocation of the `E1430A_TRY` macro overwrites the previous invocation; i.e. the TRY-RECOVER mechanism can not be nested.

RETURN VALUE

Upon successful completion an address is returned, otherwise a NULL is returned. If there is no HP E1430A at the logical address given by the *la* parameter, the error, `ERR1430_NO_MOD_AT_LA` will be returned.

e1430_get_resample_data

Take the input buffer data, filter it, resample, and return in the output buffer.

SYNOPSIS

```
#include "e1430.h"

SHORTSIZ16 int e1430_get_resample_data(*in_buffer,*out_buffer,*rec,clock,size,
filter,bw_num,dt,*re,*time,*out_size)

FLOATSIZ32 *in_buffer
FLOATSIZ32 *out_buffer
FLOATSIZ32 *rec
SHORTSIZ16 clock
LONGSIZ32 size
SHORTSIZ16 filter
SHORTSIZ16 bw_num
FLOATSIZ32 dt
FLOATSIZ32 *re
FLOATSIZ32 *time
LONGSIZ32 *out_size
```

DESCRIPTION

E1430_get_resample_data returns a block of floating point data that has been filtered and resampled with respect to the calling parameters. The scaling of the resampled data is the same as the scaling of the original raw data. Both the *in_buffer* and the *out_buffer* represent REAL data.

This function compensates for the analog and digital filters of the HP E1430A, and provides incorrect results if the analog filter is not used, or if incorrect information about how the data was collected is passed on to the function. When the HP E1430A digital filters are used (decim_bw 0), proper operation of the function requires that the final 2x decimation be turned on by using the *e1430_set_decimation_state* function.

in_buffer is the buffer containing the data to be filtered and resampled. its size is indicated by the size parameter in the parameter list.

out_buffer is the buffer containing the data that has been filtered. This buffer is sized and allocated by the calling program.

The size of the *out_buffer* must be sufficient to hold the number of samples indicated by the following formula. The return value of the function will indicate how many output samples were actually generated.

$$\text{size} = (1 + (\text{size}(\text{in_buffer}) + 1 + \text{time}) * \text{dt})$$

rec is a fixed buffer of 12 points (0 to 11) which represents the data in the compensation filters. For single HP E1430A systems, this buffer is zeroed in the block mode and contains previous good data in the continuous mode. If multiple HP E1430A's are used in the continuous mode the user must provide interim storage between calls to different HP E1430A's.

clock is a value which depends on the value of the HP E1430A clock. This value can be found by checking the status register or using the `status long` command in the demo program. 0 = 10 MHz and 1 = 10.24 MHz.

size is the size of the `in_buffer`, also referred to the blocksize parameter for the HP E1430A.

filter is an integer which relates which kind of filtering is taking place.
0 = "gauss" = gaussian filtering, 1 = "flat" = linear phase filtering

0 provides a Gaussian impulse response for a non-overshooting step response. Frequency response is linear phase Gaussian with 3dB bandwidth equal to the input block sample rate/10.

1 provides flat linear phase frequency response to .35 times the input block sample rate. This preserves the time domain shape of any signal constrained to this bandwidth. See the following example.

A/D clock = 10.00 MHz, bw_num = 3
3dB Gaussian BW = 250 kHz
3dB Flat BW = 937 kHz

bw_num is an integer which is the value that the decimation of the HP E1430A was at when the data was taken. It is a number between 0 and 25. Refer to the level parameter in `e1430_set_decimation_filter` for an explanation of the `bw_num`.

dt is the ratio of the output samples to the input samples. Thus if `dt = 10` is used, 10 output samples will be generated for every input sample and the buffer output will be approximately 10 times bigger.

re is a fixed buffer of 7 points (0 to 6) which represents the resampler registers. For single HP E1430A systems, this buffer is zeroed in the block mode and contains previous good data in the continuous mode. If multiple HP E1430A's are used in the continuous mode the user must provide interim storage between calls to different HP E1430A's.

time represents the first input sample time minus the first output sample time expressed in units of input sample periods. By setting `time = -18` the initial filter/resampler conditions are not seen in the output buffer. The *time* parameter will be changed by the function to reflect the next output sample time. This value should be retained by the calling program and passed in the subsequent call to `get_resample_data` and should be used if contiguous data blocks are being processed. In block mode, the time parameter should be set each time to the desired value before calling the function.

out_size is the actual number of computed points in the `out_buffer`. This number could be used instead of the formula given above, if the exact number of points were needed for each calling of the resample function.

RETURN VALUE

Upon successful completion a value of 0 will be returned by all functions. Otherwise an error will be returned.

SEE ALSO

`e1430_set_decimation_state(E1430)`, `e1430_set_decimation_bandwidth(E1430)`

e1430_get_trigger_phase

Get trigger delay correction

SYNOPSIS

```
#include "e1430.h"

SHORTSIZ16 e1430_get_trigger_phase(la, returnPtr);
SHORTSIZ16 la;
FLOATSIZ64 *returnPtr;
```

DESCRIPTION

E1430_get_trigger_phase will calculate and return a more accurate trigger delay than the course trigger delay set by *e1430_set_trigger_delay*. The course trigger delay can only be set with a granularity of the number of output samples in an 8 byte block. In addition, when the decimation filter is on there are delays between the SYNC transition and first data sample in the FIFO that vary depending on the level of decimation. This function corrects the programmed trigger delay to account for these effects with a resolution of one input sample period. The result returned is a floating point number representing output sample periods. See discussion in *e1430_set_decimation_filter* to determine the value of an output sample period. This function only works for single pass data, not multi-pass data.

Note:

This correction only accounts for data packing effects and the variable delay from SYNC transition to first sample. This correction does not cover the following sources of delay:

1. Group delay throughout the decimation filter (frequency dependent).
2. Fixed digital filter latency.
3. ADC trigger to SYNC line transition latency.
4. MAG trigger fixed latency.
5. External trigger to SYNC transition latency.
6. Phase shift due to Local Oscillator in complex data mode.

La is the logical address of a single HP E1430A.

ReturnPtr is a pointer to a memory location in which to return the corrected trigger delay.

RETURN VALUE

Upon successful completion a value of 0 is returned, otherwise an error will be returned. The error, ERR1430_NO_GROUP, is returned if an illegal value of the *groupID* parameter is used (i.e. one that was not obtained by a call to *e1430_create_module_group(E1430)*).

SEE ALSO

e1430_create_module_group(E1430), *e1430_set_trigger_delay(E1430)*, *e1430_set_decimation_filter(E1430)*.

e1430_init_io_driver

Initialize the library

SYNOPSIS

```
#include "e1430.h"
```

```
SHORTSIZ16 e1430_init_io_driver();
```

DESCRIPTION

E1430_init_io_driver must be the first routine called when using the HP E1430A library. It performs whatever initialization the I/O driver (i.e. SICL) needs for the environment in which this library is running.

RETURN VALUE

Return a value of 0 when successful, otherwise an error will be returned.

e1430_read_float32_data **e1430_get_scale_la** **e1430_read_raw_data**

Read data from FIFO, get data scale factor

SYNOPSIS

```
#include "e1430.h"

SHORTSIZ16 e1430_get_scale_la(la, &scalePtr);
SHORTSIZ16 la;
FLOATSIZ64 *scalePtr;

SHORTSIZ16 e1430_read_float32_data(la, buffer, size, adcOverload, adcError,
actualCnt);
SHORTSIZ16 la;
FLOATSIZ32 *buffer;
LONGSIZ32 size;
SHORTSIZ16 *adcOverload;
SHORTSIZ16 *adcError;
LONGSIZ32 *actualCnt;

SHORTSIZ16 e1430_read_raw_data(la, buffer, size, adcOverload, adcError,
actualCnt);
SHORTSIZ16 la;
SHORTSIZ16 *buffer;
LONGSIZ32 size;
SHORTSIZ16 *adcOverload;
SHORTSIZ16 *adcError;
LONGSIZ32 *actualCnt;
```

DESCRIPTION

E1430_read_float32_data returns a block of floating point data from the HP E1430A that has been scaled to be in volts. *E1430_read_raw_data* returns a block of raw, unscaled data from the FIFO. Both functions wait for a block of data to be ready before attempting to read the block.

These functions can only read data from the VME backplane register. The data port of the HP E1430A must be set to E1430_SEND_PORT_VME by the *e1430_set_data_port* function for these functions to be effective. To read data using the local bus in an HP E1485A environment, see the documentation for local bus data transfers in the HP E1485A documentation package.

E1430_get_scale_la calculates the correct scale factor for raw data using the current data size and range. The factor returned by this function is used to multiple raw data to get data in volts.

La is the logical address of a single HP E1430A.

Buffer is a pointer to the array for returned data.

Size is the size in bytes of *buffer*.

Note:

Always make this size less than or equal to the actual allocated memory for *buffer* or the function will overrun the buffer.

AdcOverload is a pointer to a short integer. It is set to 1 if an ADC overload occurred in the block of data just read, otherwise it is set to 0.

AdcError is a pointer to a short integer. It is set to 1 if an ADC error occurred during collection of the block of data, otherwise it is set to 0.

ActualCnt is a pointer to a long integer. It is set to the actual number of bytes transfer into *buffer*. It will always be less than or equal to *size*.

ScalePtr is a pointer to a memory location into which to place the calculated scale factor to scale raw data to volts.

RETURN VALUE

Upon successful completion a value of 0 is returned by all functions. Otherwise an error will be returned. If there is no HP E1430A at the logical address given by the *la* parameter, the error, ERR1430_NO_MOD_AT_LA will be returned. If a timeout occurs while waiting for a block of data to be present, ERR1430_DATA_READ_TIMEOUT will be returned.

SEE ALSO

e1430_create_module_group(E1430), e1430_set_blocksize(e1430), e1430_set_data_size(E1430), e1430_set_data_type(E1430).

e1430_reset_dsp

Reset the decimation filters and local oscillators on a group of HP E1430As

SYNOPSIS

```
#include "e1430.h"
```

```
SHORTSIZ16 e1430_reset_dsp(groupID);
SHORTSIZ16 groupID;
```

DESCRIPTION

E1430_reset_dsp resets the decimation filters and local oscillators of all modules in the module group *groupID*. This function is used to synchronize the phase of the local oscillators (LO) on several modules running in a synchronous group. The function resets the decimation filters, zeros the center frequency of the LO and zeros the phase of the LO for all modules in the group.

GroupID is the group ID of a single HP E1430A or a group of HP E1430As that was returned by a call to *e1430_create_module_group*.

This function should be used once after the synchronous group has been established by the *e1430_set_clock_master_mode* and *e1430_set_multi_sync* functions, and before setting the center frequency and decimation bandwidth (span). The following code is an example of the correct sequence of function calls to form a synchronous group of HP E1430As whose LOs and decimation filters are to be synchronized:

```
SHORTSIZ16 groupID;
SHORTSIZ16 laArray[3] = {129, 130, 131};

/* form group of three modules at logical addresses 129, 130 and 131 */
groupID = e1430_create_module_group(3, laArray);

/* make this group synchronous with module at 129 as master */
e1430_set_clock_master_mode(129, E1430_MASTER_CLOCK_ON);
e1430_set_multi_sync(groupID, E1430_MULTI_SYNC_ON);

/* sync up the LOs and decimation filters */
e1430_reset_dsp(groupID);

/* set center frequency and decimation filter bandwidth */
e1430_set_decimation_bandwidth(groupID, 6, 6);
e1430_set_center_frequency(groupID, .1);
```

RETURN VALUE

This function returns a value of 0 when successful. Otherwise an error will be returned. The error, ERR1430_NO_GROUP, is returned if an illegal value of the *groupID* parameter is used (i.e. one that was not obtained by a call to *e1430_create_module_group(E1430)*).

SEE ALSO

e1430_create_module_group(E1430), e1430_set_center_frequency(E1430), e1430_set_decimation_bandwidth(E1430), e1430_set_clock_master_mode(E1430), e1430_set_multi_sync(E1430).

e1430_reset_lbus

Reset the local bus

SYNOPSIS

```
#include "e1430.h"
```

```
SHORTSIZ16 e1430_reset_lbus(groupID, state);  
SHORTSIZ16 groupID;  
SHORTSIZ15 state;
```

DESCRIPTION

E1430_reset_lbus puts the local bus into reset or takes it out of reset depending on whether *state* is `E1430_RESET_LBUS_ON` or `E1430_RESET_LBUS_OFF`, respectively. Adjacent modules using the local bus must all be put into reset and then, after they all are in reset, must all be taken out of reset to avoid glitches in the local bus data. When HP E1430As are used with the HP E1485A measurement controller, the HP E1485A must be reset while all of the HP E1430As are being held in reset to avoid initial glitches in the local bus data. The HP E1430As should be taken out of reset only after the first *e1430_arm_module* is issued. The correct way to reset the local bus is as follows:

```
e1430_reset_lbus(groupID, E1430_RESET_LBUS_ON); /* hold E1430s in  
reset */
```

```
lbus_control(LBUS_CTL_RESET, 0); /* reset the E1485 lbus */
```

```
....
```

```
....
```

```
e1430_arm_module(groupID);/* first arming */
```

```
/*remove reset from E1430s, has no effect after first time */  
e1430_reset_lbus(groupID, E1430_RESET_LBUS_OFF);
```

GroupID is the group ID of a single HP E1430A or group of HP E1430As that was returned by a call to `\fRe1430_create_module_group\fr`.

RETURN VALUE

All functions return a value of 0 when successful. Otherwise an error will be returned. The error, `ERR1430_NO_GROUP`, is returned if an illegal value of the *groupID* parameter is used (i.e. one that was not obtained by a call to *e1430_create_module_group(E1430)*).

SEE ALSO

`e1430_create_module_group(E1430)`.

e1430_reset_module

Reset an HP E1430

SYNOPSIS

```
#include "e1430.h"
```

```
SHORTSIZ16 e1430_reset_module(groupID);  
SHORTSIZ16 groupID;
```

DESCRIPTION

E1430_reset_module resets all modules in the module group *groupID* and their internal data structures to their power-up state. A waiting period of 20 seconds is required after reset to allow the ADC calibration to settle to specified accuracy.

GroupID is the group ID of a single HP E1430A or a group of HP E1430As that was returned by a call to *e1430_create_module_group*.

RETURN VALUE

All functions return a value of 0 when successful. Otherwise an error will be returned. The error, ERR1430_NO_GROUP, is returned if an illegal value of the *groupID* parameter is used (i.e. one that was not obtained by a call to *e1430_create_module_group(E1430)*).

SEE ALSO

e1430_create_module_group(E1430).

e1430_save_state_file **e1430_restore_state_file**

Save/recall states

SYNOPSIS

```
#include "e1430.h"
```

```
SHORTSIZ16 e1430_restore_state_file(groupID, filename, checkla);  
SHORTSIZ16 groupID;  
char *filename;  
SHORTSIZ16 checkla;
```

```
SHORTSIZ16 e1430_save_state_file(groupID, filename);  
SHORTSIZ16 groupID;  
char *filename;
```

DESCRIPTION

E1430_save_state_file saves the internal state of a group of HP E1430As to a file. *E1430_restore_state_file* sets a group of HP E1430As to the states contained in a previously saved state file. These functions are not valid in the HP E1485A environment.

GroupID is the group ID of a single HP E1430A or group of HP E1430As that was obtained by a call to *e1430_create_module_group*.

Filename is the filename including path.

Checkla can enable/disable a check that matches the logical addresses of the internal states stored in the file with available logical addresses of HP E1430As whose states are to be restored. `E1430_CHECK_LA_MISMATCH` checks that each logical address in the state file matches one in the module group.

`E1430_IGNORE_LA_MISMATCH` disables the check, and states are restored in the group in the order that they are found in the file.

RETURN VALUE

Upon successful completion a value of 0 is returned by all functions. Otherwise an error will be returned. The error, `ERR1430_NO_GROUP`, is returned if an illegal value of the *groupID* parameter is used (i.e. one that was not obtained by a call to *e1430_create_module_group(E1430)*). If logical address match checking is enabled and a mismatch occurs, *e1430_restore_state_file* will return the error, `ERR1430_MISMATCH_STATEFILE`. Possible file system errors are: `ERR1430_OPEN_STATEFILE` (can't open file), `ERR1430_CLOSE_STATEFILE` (can't close file), `ERR1430_READ_STATEFILE` (can't read file), `ERR1430_WRITE_STATEFILE` (can't write file), and `ERR1430_NOT_STATEFILE` (not a statefile).

SEE ALSO

`e1430_create_module_group(E1430)`.

e1430_set_adc_clock **e1430_get_adc_clock**

Get and set ADC clock source

SYNOPSIS

```
#include "e1430.h"

SHORTSIZ16 e1430_get_adc_clock(groupID, *sourcePtr);
SHORTSIZ16 groupID;
SHORTSIZ16 *sourcePtr;

SHORTSIZ16 e1430_set_adc_clock(groupID, adcClock);
SHORTSIZ16 groupID;
SHORTSIZ16 adcClock;
```

DESCRIPTION

E1430_set_adc_clock is used to set the source of the sample clock for the ADC. *E1430_get_adc_clock* returns the current source of the ADC clock.

groupID is the group ID of a single HP E1430A or group of HP E1430As that was obtained by a call to *e1430_create_module_group*.

AdcClock selects the clock source. When set to `E1430_ADC_CLOCK_INTERNAL` the clock source is the internal 10MHz (or 10.24MHz depending on option) oscillator. Setting it to `E1430_ADC_CLOCK_EXTERNAL` selects the TTL signal on the external clock input connector.

SourcePtr is a pointer to a memory location in which to return the current value of the *adcClock* parameter for an HP E1430A or group of HP E1430As.

RETURN VALUE

Upon successful completion a value of 0 is returned by all functions, otherwise an error will be returned. Setting the *adcClock* to an illegal value will cause the function to return the error, `ERR1430_ILLEGAL_ADC_CLOCK_SOURCE`. If *e1430_get_adc_clock* is called to get the current parameter value of a group of HP E1430As and that parameter is not the same for all modules in the group, then the error, `ERR1430_PARAMETER_UNEQUAL`, is returned. The error, `ERR1430_NO_GROUP`, is returned if an illegal value of the *groupID* parameter is used (i.e. one that was not obtained by a call to *e1430_create_module_group(E1430)*).

SEE ALSO

e1430_create_module_group(E1430).

e1430_set_analog_input

Set all analog input parameters

SYNOPSIS

```
#include "e1430.h"
```

```
SHORTSIZ16 e1430_set_analog_input(groupID, range, coupling, state, inHi, inLo);  
SHORTSIZ16 groupID;  
FLOATSIZ64 range;  
SHORTSIZ16 coupling;  
SHORTSIZ16 state;  
SHORTSIZ16 inHi;  
SHORTSIZ16 inLo;
```

DESCRIPTION

E1430_set_analog_input will set all of the analog input parameters in one function call. It is also possible to set the parameter individually.

GroupID is the group ID of a single HP E1430A or group of HP E1430As that was obtained by a call to *e1430_create_module_group*.

Range is the full scale range in volts. Signal inputs whose absolute value is larger than full scale will generate an ADC overflow error. The discrete legal values of *range* vary between 0.0078125 and 8.0 volts by powers of two. The actual range that is set will be the nearest legal range value that is greater than or equal to the value specified by the *range* parameter. If a value is specified that is greater than the maximum range, the range is set to the maximum, 8.0 volts.

Coupling determines the AC or DC coupling mode of the input. Using *E1430_COUPLING_DC* will connect the input directly to the 50 ohm buffer amplifier. *E1430_COUPLING_AC* inserts a series capacitor between the input connector and the 50 ohm buffer amplifier. The function will return *ERR1430_ILLEGAL_COUPLING* if anything other than the legal values for this parameter is specified.

State determines the state of the analog anti-alias filter in the front end. *E1430_ANTIALIAS_ON* connects the filter and *E1430_ANTIALIAS_OFF* bypasses the anti-alias filter. The function returns the error, *ERR1430_ILLEGAL_ANTI_ALIAS_MODE* if an illegal entry is used for the *state* parameter.

InHi selects the input to the ADC. *E1430_INPUT_HI_CONN* selects the *Analog Input* connector as the ADC input. *E1430_INPUT_HI_GROUND* grounds the ADC input. The function will return *ERR1430_ILLEGAL_INPUT_SOURCE* if anything other than the legal values for this parameter is specified.

InLo selects the grounding of the input connector shell.

E1430_INPUT_LO_FLOAT grounds the shell through a parallel combination of a 50 ohm resistor and a 0.04 uF capacitor. This provides sufficient impedance to suppress low frequency ground loop pickup. The maximum common mode voltage is limited to +/- .7 volts by a pair of 3 amp diodes.

E1430_INPUT_LO_GROUND grounds the connector shell to the chassis. The function will return ERR1430_ILLEGAL_INPUT_SOURCE if anything other than the legal values for this parameter is specified.

RETURN VALUE

Upon successful completion a value of 0 is returned, otherwise an error will be returned. The error, ERR1430_NO_GROUP, is returned if an illegal value of the *groupID* parameter is used (i.e. one that was not obtained by a call to *e1430_create_module_group(E1430)*).

SEE ALSO

e1430_create_module_group(E1430), *e1430_set_range(E1430)*,
e1430_set_coupling(E1430), *e1430_set_anti_alias_filter(E1430)*,
e1430_set_input_high(E1430), *e1430_set_input_low(E1430)*

e1430_set_anti_alias_filter **e1430_get_anti_alias_filter**

Set or get state of anti alias filter

SYNOPSIS

```
#include "e1430.h"
```

```
SHORTSIZ16 e1430_set_anti_alias_filter(groupID, state);  
SHORTSIZ16 groupID;  
SHORTSIZ16 state;
```

```
SHORTSIZ16 e1430_get_anti_alias_filter(groupID, statePtr);  
SHORTSIZ16 groupID;  
SHORTSIZ16 *statePtr;
```

DESCRIPTION

E1430_set_anti_alias_filter sets the state of the anti_alias filter either on or off. It is recommended that the filter is always on to insure bandlimited, anti-aliased data input.

GroupID is the group ID of a single HP E1430A or group of HP E1430As that was obtained by a call to *e1430_create_module_group*.

State determines the state of the analog anti-alias filter in the front end. E1430_ANTIALIAS_ON connects the filter and E1430_ANTIALIAS_OFF bypasses the anti-alias filter.

StatePtr is a pointer to a memory location in which to return the current value of the state parameter for an HP E1430A or group of HP E1430As.

RETURN VALUE

Upon successful completion a value of 0 is returned, otherwise an error will be returned. The function returns the error, ERR1430_ILLEGAL_ANTI_ALIAS_MODE if an illegal entry is used for the *state* parameter.

If *e1430_get_anti_alias_filter* is called to get the current parameter value of a group of HP E1430As and that parameter is not the same for all modules in the group, then the error, ERR1430_PARAMETER_UNEQUAL, is returned. The error, ERR1430_NO_GROUP, is returned if an illegal value of the *groupID* parameter is used (i.e. one that was not obtained by a call to *e1430_create_module_group(E1430)*).

SEE ALSO

e1430_create_module_group(E1430).

e1430_set_append_status **e1430_get_append_status**

Get and set append status flag

SYNOPSIS

```
#include "e1430.h"

SHORTSIZ16 e1430_get_append_status(groupID, appendPtr);
SHORTSIZ16 groupID;
SHORTSIZ16 *appendPtr;

SHORTSIZ16 e1430_set_append_status(groupID, append);
SHORTSIZ16 groupID;
SHORTSIZ16 append;
```

DESCRIPTION

E1430_set_append_status selects whether or not status information is appended to the end of each data block sent by an HP E1430.

GroupID is the group ID of a single HP E1430A or group of HP E1430As that was obtained by a call to *e1430_create_module_group*.

Append set to `E1430_APPEND_STATUS_ON` means that an extra byte of status information is appended to the end of each data block to indicate whether an ADC overload or error happened during the collection of that block of data. In this status byte, Bit 0 will be set if an ADC overload happened and bit 1 will be set for an ADC error. The other bits are undefined. When the appended byte is transferred via the VME backplane, the byte is located in the lower 8 bits of the 16 bit transfer. The upper 8 bits are undefined. When the appended byte is output via the local bus, it is marked as the last byte of a transfer block. This status byte should be read separately from any block read operations in order to not affect the alignment of subsequent 16 or 32 bit data elements. `E1430_APPEND_STATUS_OFF` disables this feature.

AppendPtr is a pointer to a memory location in which to return the current value of of the append status state for an HP E1430A or group of HP E1430As.

RETURN VALUE

Upon successful completion a value of 0 is returned, otherwise an error will be returned. For an illegal value of the *append* parameter, the error, `ERR1430_ILLEGAL_APPEND_STATUS`, is returned. If *e1430_get_append_status* is called to get the current parameter value of a group of HP E1430As and that parameter is not the same for all modules in the group, then the error, `ERR1430_PARAMETER_UNEQUAL`, is returned. The error, `ERR1430_NO_GROUP`, is returned if an illegal value of the *groupID* parameter is used (i.e. one that was not obtained by a call to *e1430_create_module_group(E1430)*).

SEE ALSO

e1430_create_module_group(E1430).

e1430_set_blocksize **e1430_get_blocksize**

Get and set data block size

SYNOPSIS

```
#include "e1430.h"
```

```
SHORTSIZ16 e1430_get_blocksize(groupID, sizePtr);  
SHORTSIZ16 groupID;  
SHORTSIZ16 *sizePtr;
```

```
SHORTSIZ16 e1430_set_blocksize(groupID, blocksize);  
SHORTSIZ16 groupID;  
LONGSIZ32 blocksize;
```

DESCRIPTION

E1430_set_blocksize sets the blocksize of the data block to be gathered by a group of HP E1430As.

GroupID is the group ID of a single HP E1430A or group of HP E1430As that was obtained by a call to *e1430_create_module_group*.

Blocksize selects number of sample points in a block. The number of bytes represented by this blocksize varies depending on the data format. The actual blocksize will be set to size that is the nearest power of 2 less than or equal to the *blocksize* parameter specified in the function call. The following table illustrates the dependence of blocksize on data size and type:

Type	Size	Bytes Per Sample	Minimum Blocksize
real	16	2	4
real	32	4	2
complex	16	4	2
complex	32	8	1

Specifying *blocksize* less than the minimum will result in the blocksize being set to the minimum. Specifying *blocksize* larger than the FIFO can support will result in the blocksize being set the largest value for which the data will all fit in the FIFO.

SizePtr is a pointer to a memory location in which to return the current value of the blocksize for an HP E1430A or group of HP E1430As.

RETURN VALUE

Upon successful completion a value of 0 is returned, otherwise an error will be returned. If *e1430_get_blocksize* is called to get the current parameter value of a group of HP E1430As and that parameter is not the same for all modules in the group, then the error, `ERR_PARAMETER_UNEQUAL`, is returned. The error, `ERR_NO_GROUP`, is returned if an illegal value of the *groupID* parameter is used (i.e. one that was not obtained by a call to *e1430_create_module_group(E1430)*).

SEE ALSO

e1430_create_module_group(E1430).

e1430_set_center_frequency **e1430_get_center_frequency**

Set and get center frequency

SYNOPSIS

```
#include "e1430.h"
```

```
SHORTSIZ16 e1430_set_center_frequency(groupID, frequency)  
SHORTSIZ16 groupID;  
FLOATSIZ64 frequency;
```

```
SHORTSIZ16 e1430_get_center_frequency(groupID, *freqPtr)  
SHORTSIZ16 groupID;  
FLOATSIZ64 *freqPtr;
```

DESCRIPTION

E1430_set_center_frequency sets the center frequency for a zoomed measurement. Setting the center frequency to a non-zero value causes the time data from the ADC to be multiplied by a complex exponential representing this frequency. *E1430_get_center_frequency* queries the current center frequency.

Note:

When using the Local Bus, it is necessary to reset the local bus after setting the center frequency because data can be flushed into the Local Bus pipeline by this function call. See documentation under *e1430_reset_lbus()*.

GroupID is the group ID of a single HP E1430A or group of HP E1430As that was obtained by a call to *e1430_create_module_group*.

Frequency is a number between 0.0 and 1.0, which will be interpreted as a fraction of the sample frequency. For example, selecting .25 with a sample clock frequency of 10MHz will yield a center frequency of 2.5MHz.

FreqPtr is a pointer to a memory location in which to return the current value of the center frequency (as a fraction of the sample clock frequency) for a group of HP E1430As.

To set the center frequency, span and zoom state in one function, see documentation for the *e1430_set_span_zoom* function.

RETURN VALUE

Upon successful completion a value of 0 is returned by all functions. Otherwise an error will be returned. If *e1430_get_center_frequency* is called and center frequency is not the same for all modules in the group, then it returns ERR1430_PARAMETER_UNEQUAL. The error, ERR1430_NO_GROUP, is returned if an illegal value of the *groupID* parameter is used (i.e. one that was not obtained by a call to *e1430_create_module_group(E1430)*).

SEE ALSO

e1430_create_module_group(E1430).

e1430_set_clock_master_mode

Set the clock master module in a system

SYNOPSIS

```
#include "e1430.h"
```

```
SHORTSIZ16 e1430_set_clock_master_mode(la, masterState);  
SHORTSIZ16 la;  
SHORTSIZ16 masterState;
```

DESCRIPTION

E1430_set_clock_master_mode is used enable or disable one of the HP E1430As in a mainframe to drive the master clock line on the VXI backplane with its internal ADC clock. This is used for multi-module synchronization.

Only one module per mainframe can be enabled to drive the clock line on the backplane. An alternative way to drive the backplane clock line is to connect the Clock Extend Input of an HP E1430A in one mainframe to the Clock Extend Output of an HP E1430A in another mainframe which has a clock master enabled. When the clock extender is used, no HP E1430As in the slave mainframe may be programmed as a clock master.

Note:

If an entire group is put into multi-sync mode, one HP E1430A must have previously been set up as a clock master OR an external clock must be applied to to the Mainframe extender ECL CLOCK connector. OTHERWISE, serious communications problems will occur with bus errors and measurement timeouts being returned from most e1430 commands.

La is the logical address of a single HP E1430.

MasterState determines whether an HP E1430A makes its local ADC clock available on the VXI backplane. Setting this parameter to `E1430_MASTER_CLOCK_ON` causes the HP E1430A located at logical address, *la*, to drive the VXI backplane in the mainframe in which it resides with its ADC clock. `E1430_MASTER_CLOCK_OFF` means that the HP E1430A is not driving the backplane.

The correct method to set up a synchronous multi-module group that insures that the local oscillators on each module are synchronized is:

```
/* first, insure one module is putting its clock on the backplane, or  
* the next function call could result in a hang  
*/  
e1430_set_clock_master_mode(logicalAddr, E1430_MASTER_CLOCK_ON);  
  
/* put whole group into multi-sync mode with internal clock (unless  
* external clock is connected to master E1430 through Ext Clk TTL  
* connector.)  
*/
```



```
e1430_set_clock_mode(groupID,E1430_MULTI_SYNC_ON,  
E1430_ADC_CLOCK_INTERNAL,  
E1430_DSP_CLOCK_ADC);
```

```
/* synchronize the decimation filter and local oscillators */  
e1430_reset_dsp(groupID);
```

RETURN VALUE

Upon successful completion a value of 0 is returned, otherwise an error will be returned. Setting the *masterState* parameter to any value other than the two listed above will cause the function to return the error, ERR1430_ILLEGAL_CLOCK_MASTER_MODE. If there is no HP E1430A at the logical address given by the *la* parameter, the error, ERR1430_NO_MOD_AT_LA will be returned.

SEE ALSO

e1430_reset_dsp(E1430).

e1430_set_clock_mode

Set all timing parameters

SYNOPSIS

```
#include "e1430.h"
```

```
SHORTSIZ16 e1430_set_clock_mode(groupID, syncState, adcClock, dspClock);  
SHORTSIZ16 groupID;  
SHORTSIZ16 syncState;  
SHORTSIZ16 adcClock;  
SHORTSIZ16 dspClock;
```

DESCRIPTION

E1430_set_clock_mode is used to configure all timing parameters used for sampling (ADC clock) and decimation/zoom (DSP clock). There are also functions to set these parameters individually.

GroupID is the group ID of a single HP E1430A or group of HP E1430As that was obtained by a call to *e1430_create_module_group*.

SyncState is used to select the source of the ADC clock and synchronization. The HP E1430A supports synchronous operation among multiple HP E1430As by using a VXI ECL line to drive all the modules in a system from the same clock. If this parameter is set to `E1430_MULTI_SYNC_OFF`, the ADC clock and SYNC are generated locally. If *syncState* is set to `E1430_MULTI_SYNC_ON` the module uses the ADC clock distributed on the VXI backplane, overriding the selection indicated by the *adcClock* parameter. This mode also uses the SYNC line for multi-module synchronization capabilities including: arming, triggering, initialization of the zoom local oscillator phase and decimation. Setting this parameter to any other value will cause the function to return the error, `ERR1430_ILLEGAL_MULTI_SYNC_MODE`.

Note:

If an entire group is put into multi-sync mode, one HP E1430A must have previously been set up as clock master. See *e1430_set_clock_master_mode* for an example of setting up multi-module synchronous groups.

AdcClock selects the clock source that is used to drive the analog to digital converter (ADC). When set to `E1430_ADC_CLOCK_INTERNAL` the clock source is the internal 10MHz oscillator. `E1430_ADC_CLOCK_EXTERNAL` selects the TTL signal on the external clock input connector. Setting this parameter to any other value will cause the function to return the error, `ERR1430_ILLEGAL_ADC_CLOCK_SOURCE`.

DspClock selects the clock used to drive the decimation/zoom section within the HP E1430. It is not required to be the same as the ADC clock, although this is the normal case. When a slow external ADC clock is used, the signal processing and data transfers may be unnecessarily slowed down. To avoid this problem there is an option to run the DSP clock from a separate, faster source. The disadvantage of doing this is that specified analog performance will degrade due to spurious pickup by the sensitive analog hardware. Setting this parameter to `E1430_DSP_CLOCK_ADC` forces the DSP clock to be driven by the ADC clock. `E1430_DSP_CLOCK_INTERNAL` will cause the DSP clock to be the internally generated 10MHz oscillator. Note that the computed results will be the same in either case. Setting this parameter to any other value will cause the function to return the error, `ERR1430_ILLEGAL_DSP_CLOCK_SOURCE`.

RETURN VALUE

Upon successful completion a value of 0 is returned, otherwise an error will be returned. Errors caused by an illegally specified parameter are described above. The error, `ERR1430_NO_GROUP`, is returned if an illegal value of the *groupID* parameter is used (i.e. one that was not obtained by a call to `e1430_create_module_group(E1430)`).

SEE ALSO

`e1430_create_module_group(E1430)`.

e1430_set_coupling **e1430_get_coupling**

Set or get input coupling

SYNOPSIS

```
#include "e1430.h"
```

```
SHORTSIZ16 e1430_set_coupling(groupID, coupling);  
SHORTSIZ16 groupID;  
SHORTSIZ16 coupling;
```

```
SHORTSIZ16 e1430_get_coupling(groupID, couplingPtr);  
SHORTSIZ16 groupID;  
SHORTSIZ16 *couplingPtr;
```

DESCRIPTION

E1430_set_coupling sets input coupling of the analog input section of an HP E1430A or a group of E1430s. *E1430_get_coupling* queries the current setting of the coupling parameter.

GroupID is the group ID of a single HP E1430A or group of HP E1430As that was obtained by a call to *e1430_create_module_group*.

Coupling determines the AC or DC coupling mode of the input. Using `E1430_COUPLING_DC` will connect the input directly to the 50 ohm buffer amplifier. `E1430_COUPLING_AC` inserts a series capacitor between the input connector and the 50 ohm buffer amplifier.

CouplingPtr is a pointer to a memory location in which to return the current value of the coupling parameter for an HP E1430A or group of HP E1430As.

RETURN VALUE

Upon successful completion a value of 0 is returned, otherwise an error will be returned. The set function returns the error, `ERR1430_ILLEGAL_COUPLING` if anything other than the two legal values is used for the *coupling* parameter. If *e1430_get_coupling* is called to get the current parameter value of a group of E1430s and that parameter is not the same for all modules in the group, then the error, `ERR1430_PARAMETER_UNEQUAL`, is returned. The error, `ERR1430_NO_GROUP`, is returned if an illegal value of the *groupID* parameter is used (i.e. one that was not obtained by a call to *e1430_create_module_group(E1430)*).

SEE ALSO

`e1430_create_module_group(E1430)`.

e1430_set_data_format

Set all data format parameters

SYNOPSIS

```
#include "e1430.h"

SHORTSIZ16 e1430_set_data_format(groupID, type, size, mode, blocksize, append);
SHORTSIZ16 groupID;
SHORTSIZ16 type;
SHORTSIZ16 size;
SHORTSIZ16 mode;
LONGSIZ32 blocksize;
SHORTSIZ16 append;
```

DESCRIPTION

E1430_set_data_format sets all of the parameters associated with data size and format.

GroupID is the group ID of a single HP E1430A or group of HP E1430As that was obtained by a call to *e1430_create_module_group*.

Type determines whether the HP E1430A returns real or complex data. Setting this parameter to `E1430_DATA_TYPE_REAL` causes only the real part of the data to be returned for each sample. `E1430_DATA_TYPE_COMPLEX` causes the real data followed by the imaginary data to be returned in each sample. Any other choice for this parameter will cause the function to return with the error, `ERR1430_ILLEGAL_DATA_TYPE`.

Size selects the number of bits of precision for the fixed point, two's complement data outputs from the HP E1430. Choosing 16-bit precision allows for more samples in the FIFO memory. Choosing 32 bits allows more dynamic range. The legal values for this parameter are `E1430_DATA_SIZE_32` and `E1430_DATA_SIZE_16`. Any other values will cause the function to return the error, `ERR1430_ILLEGAL_DATA_SIZE`.

Blocksize selects number of sample points in a block. The number of bytes represented by this blocksize varies depending on the data format. The actual blocksize will be set to size that is the nearest power of 2 less than or equal to the *blocksize* parameter specified in the function call. The following table illustrates the dependence of blocksize on data size and type:

Type	Size	Bytes Per Sample	Minimum Blocksize
real	16	2	4
real	32	4	2
complex	16	4	2
complex	32	8	1

Specifying *blocksize* less than the minimum will result in the blocksize being set to the minimum. Specifying *blocksize* larger than the FIFO can support will result in the blocksize being set the largest value for which the data will all fit in the FIFO.

Mode selects whether the HP E1430's data collection operates in block mode or continuous mode. `E1430_BLOCK_MODE` selects block transfer mode. The HP E1430A will stop collecting data as soon as one block of data has been collected. `E1430_CONTINUOUS_MODE` means data collection will be continuous, until the FIFO on the HP E1430A overflows or until the module is explicitly programmed to the IDLE state. Any other value for this parameter will cause the function to return the error, `ERR1430_ILLEGAL_DATA_MODE`.

Append selects whether or not status information is appended to a data block. Specifying `E1430_APPEND_STATUS_ON` means that an extra byte of status information is appended to the end of each data block to indicate whether an ADC overload or error happened during the collection of that block of data. In this status byte, Bit 0 will be set if an ADC overload happened and bit 1 will be set for an ADC error. The other bits are undefined. When the appended byte is transferred via the VME backplane, the byte is located in the lower 8 bits of the 16 bit transfer. The upper 8 bits are undefined. When the appended byte is output via the local bus, it is marked as the last byte of a transfer block. This status byte should be read separately from any block read operations in order to not affect the alignment of subsequent 16 or 32 bit data elements. `E1430_APPEND_STATUS_OFF` disables this feature. Any other value returns the error, `ERR1430_ILLEGAL_APPEND_STATUS`.

RETURN VALUE

Upon successful completion a value of 0 is returned by all functions. Otherwise an error will be returned. The error values returned because of an illegally specified parameter are described above. If a query function is called to get the current parameter value of a group of HP E1430As and that parameter is not the same for all modules in the group, then the error, `ERR1430_PARAMETER_UNEQUAL`, is returned. The error, `ERR1430_NO_GROUP`, is returned if an illegal value of the *groupID* parameter is used (i.e. one that was not obtained by a call to `e1430_create_module_group(E1430)`).

SEE ALSO

`e1430_create_module_group(E1430)`.

e1430_set_data_mode **e1430_get_data_mode**

Get and set data output mode

SYNOPSIS

```
#include "e1430.h"
```

```
SHORTSIZ16 e1430_get_data_mode(groupID, modePtr);  
SHORTSIZ16 groupID;  
SHORTSIZ16 *modePtr;
```

```
SHORTSIZ16 e1430_set_data_mode(groupID, mode);  
SHORTSIZ16 groupID;  
SHORTSIZ16 mode;
```

DESCRIPTION

E1430_set_data_mode sets a group of HP E1430s into block or continuous data collection mode.

GroupID is the group ID of a single HP E1430A or group of HP E1430As that was obtained by a call to e1430_create_module_group.

Mode selects whether the HP E1430's data collection operates in block mode or continuous mode. E1430_BLOCK_MODE selects block transfer mode. The HP E1430A will stop collecting data as soon as one block of data has been collected. E1430_CONTINUOUS_MODE means data collection will be continuous, until the FIFO on the E1430 overflows or until the module is explicitly programmed to the IDLE state.

ModePtr is a pointer to a memory location in which to return the current value of data collection mode parameter for an HP E1430A or group of HP E1430As.

RETURN VALUE

Upon successful completion a value of 0 is returned, otherwise an error will be returned. An illegal value for the *mode* parameter will cause the function to return the error, ERR1430_ILLEGAL_DATA_MODE. If *e1430_get_data_mode* is called to get the current parameter value of a group of HP E1430As and that parameter is not the same for all modules in the group, then the error, ERR1430_PARAMETER_UNEQUAL, is returned. The error, ERR1430_NO_GROUP, is returned if an illegal value of the *groupID* parameter is used (i.e. one that was not obtained by a call to *e1430_create_module_group(E1430)*).

SEE ALSO

e1430_create_module_group(E1430).

e1430_set_data_port **e1430_get_data_port**

Get and set data port parameter

SYNOPSIS

```
#include "e1430.h"
```

```
SHORTSIZ16 e1430_get_data_port(groupID, portPtr);  
SHORTSIZ16 groupID;  
SHORTSIZ16 *portPtr;
```

```
SHORTSIZ16 e1430_set_data_port(groupID, port);  
SHORTSIZ16 groupID;  
SHORTSIZ16 port;
```

DESCRIPTION

E1430_set_data_port sets the HP E1430A to deliver data either on the VME backplane or on the Local Bus.

GroupID is the group ID of a single HP E1430A or group of HP E1430As that was obtained by a call to *e1430_create_module_group*.

Port determines the path used to return data to the host.

E1430_SEND_PORT_VME causes data to be sent via the VME bus.

E1430_SEND_PORT_LBUS causes data to be transmitted via the Local Bus. In the E1430_SEND_PORT_LBUS mode, a group of HP E1430As must be contiguous in one mainframe and positioned to left of the host module (i.e. HP E1485A). If the host environment does not support the Local Bus, the function will return ERR1430_LOCAL_BUS_UNSUPPORTED.

PortPtr is a pointer to a memory location in which to return the current value of port parameter for an HP E1430A or group of HP E1430As.

RETURN VALUE

Upon successful completion a value of 0 is returned, otherwise an error will be returned. If other than the two legal choices for the *port* parameter are used the function will return the error, ERR1430_ILLEGAL_DATA_PORT. If *e1430_get_data_port* is called to get the current value of the port parameter of a group of HP E1430As and that parameter is not the same for all modules in the group, then the error, ERR1430_PARAMETER_UNEQUAL, is returned. The error, ERR1430_NO_GROUP, is returned if an illegal value of the *groupID* parameter is used (i.e. one that was not obtained by a call to *e1430_create_module_group(E1430)*).

SEE ALSO

e1430_create_module_group(E1430).

e1430_set_data_reread **e1430_get_data_reread**

Get and set data reread

SYNOPSIS

```
#include "e1430.h"

SHORTSIZ16 e1430_get_data_reread(groupID, rereadPtr);
SHORTSIZ16 groupID;
SHORTSIZ16 *rereadPtr;

SHORTSIZ16 e1430_set_data_reread(groupID, reread);
SHORTSIZ16 groupID;
SHORTSIZ16 reread;
```

DESCRIPTION

E1430_set_data_reread enables/disable the ability to continually reread a block of data out of an HP E1430A. This is useful when the host computer does not have enough memory to read an entire block of data. When reread is enabled only one block of data can be in the FIFO and an attempt to read past the end of the block will result in wrapping around to the beginning of the block.

GroupID is the group ID of a single HP E1430A or group of HP E1430As that was obtained by a call to *e1430_create_module_group*.

Reread enables/disables block reread. E1430_DATA_REREAD_OFF disables this ability and E1430_DATA_REREAD_ON enables it.

RereadPtr is a pointer to a memory location in which to return the current value of *reread* parameter for an HP E1430A or group of HP E1430As.

RETURN VALUE

Upon successful completion a value of 0 is returned, otherwise an error will be returned. Values for the *reread* parameter other than those mentioned above will cause the function to return the error, ERR1430_ILLEGAL_DATA_REREAD. If *e1430_get_data_reread* is called to get the current parameter value of a group of HP E1430As and that parameter is not the same for all modules in the group, then the error, ERR1430_PARAMETER_UNEQUAL, is returned. The error, ERR1430_NO_GROUP, is returned if an illegal value of the *groupID* parameter is used (i.e. one that was not obtained by a call to *e1430_create_module_group(E1430)*).

SEE ALSO

e1430_create_module_group(E1430).

e1430_set_data_size **e1430_get_data_size**

Get and set data size

SYNOPSIS

```
#include "e1430.h"
```

```
SHORTSIZ16 e1430_get_data_size(groupID, returnPtr);  
SHORTSIZ16 groupID;  
SHORTSIZ16 *returnPtr;
```

```
SHORTSIZ16 e1430_set_data_size(groupID, size);  
SHORTSIZ16 groupID;  
SHORTSIZ16 size;
```

DESCRIPTION

E1430_set_data_size sets the precision of the data output by an HP E1430.

GroupID is the group ID of a single HP E1430A or group of HP E1430As that was obtained by a call to *e1430_create_module_group*.

SizePtr is a pointer to a memory location in which to return the current value of *size* parameter for an HP E1430A or group of HP E1430As.

Size selects the number of bits of precision for the fixed point, two's complement data outputs from the HP E1430A. Choosing 16-bit precision allows for more samples in the FIFO memory. Choosing 32 bits allows more dynamic range. The legal values for this parameter are `E1430_DATA_SIZE_32` and `E1430_DATA_SIZE_16`.

RETURN VALUE

Upon successful completion a value of 0 is returned, otherwise an error will be returned. Values for the *size* parameter other than those mentioned above will cause the function to return the error, `ERR1430_ILLEGAL_DATA_SIZE`. If *e1430_get_data_size* is called to get the current parameter value of a group of HP E1430As and that parameter is not the same for all modules in the group, then the error, `ERR1430_PARAMETER_UNEQUAL`, is returned. The error, `ERR1430_NO_GROUP`, is returned if an illegal value of the *groupID* parameter is used (i.e. one that was not obtained by a call to *e1430_create_module_group(E1430)*).

SEE ALSO

`e1430_create_module_group(E1430)`.

e1430_set_data_type **e1430_get_data_type**

Get and set data type

SYNOPSIS

```
#include "e1430.h"

SHORTSIZ16 e1430_get_data_type(groupID, typePtr);
SHORTSIZ16 groupID;
SHORTSIZ16 *typePtr;

SHORTSIZ16 e1430_set_data_type(groupID, type);
SHORTSIZ16 groupID;
SHORTSIZ16 type;
```

DESCRIPTION

E1430_set_data_type sets the data type to real or complex.

GroupID is the group ID of a single HP E1430A or group of HP E1430As that was obtained by a call to *e1430_create_module_group*.

TypePtr is a pointer to a memory location in which to return the current value of individual data type parameter for an HP E1430A or group of HP E1430As.

Type determines whether the HP E1430A returns real or complex data. Setting this parameter to `E1430_DATA_TYPE_REAL` causes only real, unzoomed data to be returned for each sample. Setting it to `E1430_DATA_TYPE_COMPLEX` results in complex data being output.

RETURN VALUE

Upon successful completion a value of 0 is returned, otherwise an error will be returned. Any choice for the *type* parameter other than the values mentioned above will cause the function to return with the error, `ERR1430_ILLEGAL_DATA_TYPE`. If *e1430_get_data_type* is called to get the current parameter value of a group of HP E1430As and that parameter is not the same for all modules in the group, then the error, `ERR1430_PARAMETER_UNEQUAL`, is returned. The error, `ERR1430_NO_GROUP`, is returned if an illegal value of the *groupID* parameter is used (i.e. one that was not obtained by a call to *e1430_create_module_group(E1430)*).

SEE ALSO

e1430_create_module_group(E1430).

e1430_set_decimation_bandwidth **e1430_get_decimation_bandwidth** **e1430_get_trigger_bandwidth**

Get or set bandwidth of decimation filter

SYNOPSIS

```
#include "e1430.h"

SHORTSIZ16 e1430_get_decimation_bandwidth(groupID, bwPtr);
SHORTSIZ16 groupID;
SHORTSIZ16 *bwPtr;

SHORTSIZ16 e1430_get_trigger_bandwidth(groupID, bwPtr);
SHORTSIZ16 groupID;
SHORTSIZ16 *bwPtr;

SHORTSIZ16 e1430_set_decimation_bandwidth(groupID, dataBw, triggerBw);
SHORTSIZ16 groupID;
SHORTSIZ16 dataBw;
SHORTSIZ16 triggerBw;
```

DESCRIPTION

E1430_set_decimation_bandwidth allows setting the filter bandwidth for output data and triggering separately. The concept of trigger bandwidth makes sense only in the case of magnitude triggering. *E1430_get_decimation_bandwidth* and *e1430_get_trigger_bandwidth* return the data bandwidth and trigger bandwidth respectively. Normally these are both set to the same value.

Note:

Using these functions while a measurement is running will force all HP E1430As in the group into the IDLE state.

GroupID is the group ID of a single HP E1430A or group of HP E1430As that was obtained by a call to *e1430_create_module_group*.

DataBw and *triggerBw* selects the bandwidth of the filter and the amount of decimation applied to the signal. The *dataBw* parameter applies to the filtering of data to be output from the HP E1430, while the *triggerBw* applies to the filtering of the signal into the trigger circuitry. These bandwidths can be set to different values. If one of these parameters is set to zero, all filtering except the analog anti-alias filter is disabled, allowing potential aliasing. The relationship of these bandwidth parameters to filter bandwidth and filter output sample rate is discussed under the *level* and *state* parameters of the *e1430_set_decimation_filter* function.

BwPtr is a pointer to a memory location in which to return the current value of either the data or triggering bandwidth parameter for an HP E1430A or group of HP E1430As.

RETURN VALUE Upon successful completion a value of 0 is returned, otherwise an error will be returned. If *e1430_get_decimation_bandwidth* or *e1430_get_trigger_bandwidth* are called to get the current parameter value of a group of HP E1430As and that parameter is not the same for all modules in the group, then the error, ERR1430_PARAMETER_UNEQUAL, is returned. The error, ERR1430_NO_GROUP, is returned if an illegal value of the *groupID* parameter is used (i.e. one that was not obtained by a call to *e1430_create_module_group(E1430)*).

SEE ALSO *e1430_create_module_group(E1430)*.

e1430_set_decimation_filter

Set all decimation filter parameters

SYNOPSIS

```
#include "e1430.h"
```

```
SHORTSIZ16 e1430_set_decimation_filter(groupID, level, state, output, tag)  
SHORTSIZ16 groupID;  
SHORTSIZ16 level;  
SHORTSIZ16 state;  
SHORTSIZ16 output;  
SHORTSIZ16 tag;
```

DESCRIPTION

E1430_set_decimation_filter sets all parameters associated with the decimation filter of an HP E1430. Decimation allows data reduction on oversampled data, saving only those points needed to reconstruct the waveform. A decimation of 2 keeps every other data point, a decimation of 4 keeps every fourth data point, etc. The bandwidth of the data must be reduced at the same time to prevent aliasing.

Note:

Using this function while a measurement is running will force all HP E1430As in the group into the IDLE state.

GroupID is the group ID of a single HP E1430A or group of HP E1430As that was obtained by a call to *e1430_create_module_group*. *Level* selects the bandwidth of the filter and the amount of decimation applied to the signal. It sets both the bandwidth of the signal output and the magnitude triggering circuitry to the same value. If it is desired to set these bandwidths to different values, the *e1430_set_decimation_bandwidth* function can be used. If this parameter is set to zero, all filtering except the analog anti-alias filter is disabled.

If *level* is greater than 24 it will be set to 24. If the *state* parameter is set to E1430_DECIMATION_ON, the maximum value of these parameters is 23. The total decimation level can not exceed 24. If these parameters is less than zero, the function will return the error, ERR1340_ILLEGAL_FILTER_BW.

State selects additional decimation on the output of the decimation filter. When this parameter is set to E1430_DECIMATION_OFF all samples from the decimation filter are saved. This results in oversampling by almost a factor of 2 at every *level* except zero. Using E1430_DECIMATION_ON decimates by an extra factor of 2 in addition to the decimation level set by the *level*. If this parameter is set to E1430_DECIMATION_ON when the bandwidth parameters for either the data or triggering is set to 24, these bandwidth parameters are reduced to 23. The total decimation level can not exceed 24. If a value other than these two legal values is used for *state*, the function will return the error, ERR1340_ILLEGAL_DECIMATE_MODE.

The relationship of the *level* and *state* parameters to the corresponding output sample rate and bandwidth of the decimation filter is as follows (F_s equals the sample frequency):

for *level* = 0:

output sample rate = $F_s / (2^{\text{state}})$
bandwidth in baseband mode = $F_s / (2^{(\text{state} + 1)})$
bandwidth in zoomed mode = $F_s / (2^{\text{state}})$

for *level* = 1:

output sample rate = $F_s / (2^{(\text{level} + \text{state} - 1)})$
bandwidth in baseband mode = $F_s / (2^{(\text{level} + \text{state})})$
bandwidth in zoomed mode = $F_s / (2^{(\text{level} + \text{state} - 1)})$

state = 0 for E1430_DECIMATION_OFF
state = 1 for E1430_DECIMATION_ON

Baseband mode refers to case where the center frequency has been programmed to zero and the data type programmed to real. *Zoomed mode* refers to case of an arbitrary center frequency with data type being programmed to complex. In zoomed mode the filter is centered on the center frequency and the bandwidth includes frequencies above and below this center frequency. For baseband signals, the center frequency = 0, and the bandwidth in the formula above represents the width of the filter above zero frequency. See *e1430_set_center_frequency* and *e1430_set_data_type*.

StatePtr is a pointer to a memory location in which to return the current value of the state parameter for an HP E1430A or group of HP E1430As.

Output selects the type of output from the decimation filter. The decimation filter is made up of a cascaded chain of sections, each decimating the data stream by a factor of two and reducing its bandwidth by a factor of two. Setting the output to E1430_ONEPASS selects the output of the last filter in the chain. This is the normal operating mode of the filter. Using E1430_MULTIPASS causes an output consisting of the time multiplexed outputs of all cascaded filters equal to or narrower than the programmed bandwidth. This mode is useful when gathering data for octave measurements. This mode is available only for bandwidth 0. When in the multipass mode, each data sample is tagged with a 5 bit pass number as described below. If a value other than these two legal values is used for *output*, the function will return with an error, ERR1340_ILLEGAL_FILTER_PASS_MODE.

Tag determines the position of the 5 bit pass number tag. The value of this parameter is ignored if *output* is E1430_ONEPASS. In general, the tag replaces 5 of the original data bits for each data sample. Thus the tag must be positioned to have a minimum effect on the data accuracy. In the 16 bit precision mode, the tag does not replace any data bits, but is inserted as an extra 16 bit word. The table below shows the tag location for each data type and precision. Normally the tag will be placed over the least significant data bits, however, some controllers which read the data may only implement 24 bit data precision and will not be able to read the tag. In this case *tag* is set to E1430_PASS_TAG_24 and the tag will be positioned in the bottom 5 bits of the top 24 bits in a 32 bit word. Normally *tag* is set to E1430_PASS_TAG_32. If a value other than these two legal values is used for *tag*, the function will return with an error, ERR1340_ILLEGAL_PASS_TAG.

Multi-pass output data formats

Type	Precision	Tag	r = real data, i = imaginary data, t = tag
Real	16	24 or 32	rrrrrrr rrrrrrr 0000000 000ttttt
Real	32	32	rrrrrrr rrrrrrr rrrrrrr rrrttttt
Real	32	24	rrrrrrr rrrrrrr rrrttttt rrrrrrr
Complex	16	24 or 32	rrrrrrr rrrrrrr iiiiiii iittttt
Complex	32	32	rrrrrrr rrrrrrr rrrrrrr rrrrrrr iiiiiii iiiiii iiiiii iittttt
Complex	32	24	rrrrrrr rrrrrrr rrrrrrr rrrrrrr iiiiiii iiiiii iittttt iiiiii

RETURN VALUE

Upon successful completion a value of 0 is returned, otherwise an error will be returned. The error, ERR1340_NO_GROUP, is returned if an illegal value of the *groupID* parameter is used (i.e. one that was not obtained by a call to *e1430_create_module_group(E1430)*).

SEE ALSO

e1430_create_module_group(E1430), *e1430_set_decimation_bandwidth(E1430)*, *e1430_set_decimation_output(E1430)*, *e1430_set_decimation_state(E1430)*, *e1430_set_decimation_passtag(E1430)*.

e1430_set_decimation_output **e1430_get_decimation_output**

Get or set decimation filter output mode

SYNOPSIS

```
#include "e1430.h"

SHORTSIZ16 e1430_get_decimation_output(groupID, *outputPtr);
SHORTSIZ16 groupID;
SHORTSIZ16 *outputPtr;
SHORTSIZ16 e1430_set_decimation_output(groupID, output);
SHORTSIZ16 groupID;
SHORTSIZ16 output;
```

DESCRIPTION

E1430_set_decimation_output selects which stages from the multi-stage decimation filter are output. The decimation filter is made up of a cascaded chain of sections, each decimating the data stream by a factor of two and reducing its bandwidth by a factor of two.

Note:

Using these functions while a measurement is running will force all HP E1430As in the group into the IDLE state.

GroupID is the group ID of a single HP E1430A or group of HP E1430As that was obtained by a call to *e1430_create_module_group*.

Output selects the type of output from the decimation filter. Using *E1430_ONEPASS* for this parameter selects the output of the last filter in the chain. This is the normal operating mode of the filter. Using *E1430_MULTIPASS* causes an output consisting of the time multiplexed outputs of all cascaded filters equal to or narrower than the programmed bandwidth. This mode is useful when gathering data for octave measurements. This mode is available only for bandwidth 0. When in the multipass mode, each data sample is tagged with a 5 bit pass number as described in the documentation of the *e1430_set_decimation_passtag* function.

OutputPtr is a pointer to a memory location in which to return the current value of the output parameter for an HP E1430A or group of HP E1430As.

RETURN VALUE

Upon successful completion a value of 0 is returned, otherwise an error will be returned. If a value other than the two legal values is used for *output*, the function will return with an error, *ERR1430_ILLEGAL_FILTER_PASS_MODE*. If *e1430_get_decimation_output* is called to get the current parameter value of a group of HP E1430As and that parameter is not the same for all modules in the group, then the error, *ERR1430_PARAMETER_UNEQUAL*, is returned. The error, *ERR1430_NO_GROUP*, is returned if an illegal value of the *groupID* parameter is used (i.e. one that was not obtained by a call to *e1430_create_module_group(E1430)*).

SEE ALSO

e1430_create_module_group(E1430).

e1430_set_decimation_passtag **e1430_get_decimation_passtag**

Get or set decimation filter passtag parameter

SYNOPSIS

```
#include "e1430.h"
```

```
SHORTSIZ16 e1430_get_decimation_passtag(groupID, *tagPtr);  
SHORTSIZ16 groupID;  
SHORTSIZ16 *tagPtr;
```

```
SHORTSIZ16 e1430_set_decimation_passtag(groupID, tag);  
SHORTSIZ16 groupID;  
SHORTSIZ16 tag;
```

DESCRIPTION

E1430_set_decimation_passtag sets the position of the passtag on multipass data. See the documentation for *e1430_set_decimation_output* for an explanation of multipass output.

Note:

Using this function while a measurement is running will force all HP E1430As in the group into the IDLE state.

GroupID is the group ID of a single HP E1430A or group of HP E1430As that was obtained by a call to *e1430_create_module_group*.

Tag determines the position of the 5 bit pass number tag. The value of this parameter is ignored if the decimation filter is not in the multipass mode. In general, the tag replaces 5 of the original data bits for each data sample. Thus the tag must be positioned to have a minimum effect on the data accuracy. In the 16 bit precision mode, the tag does not replace any data bits, but is inserted as an extra 16 bit word. The table below shows the tag location for each data type and precision. Normally the tag will be placed over the least significant data bits, however, some controllers which read the data may only implement 24 bit data precision and will not be able to read the tag. In this case *tag* is set to E1430_PASS_TAG_24 and the tag will be positioned in the bottom 5 bits of the top 24 bits in a 32 bit word. Normally *tag* is set to E1430_PASS_TAG_32.

TagPtr is a pointer to a memory location into which to return the current setting of the tag parameter.

Multi-pass output data formats

Type	Precision	Tag	r = real data, i = imaginary data, t = tag
Real	16	24 or 32	rrrrrrrr rrrrrrrr 00000000 000ttttt
Real	32	32	rrrrrrrr rrrrrrrr rrrrrrrr rrrttttt
Real	32	24	rrrrrrrr rrrrrrrr rrrttttt rrrrrrrr
Complex	16	24 or 32	rrrrrrrr rrrrrrrr iiiiit iittttt
Complex	32	32	rrrrrrrr rrrrrrrr rrrrrrrr rrrrrrrr iiiiit iiiiit iiiiit iittttt
Complex	32	24	rrrrrrrr rrrrrrrr rrrrrrrr rrrrrrrr iiiiit iiiiit iittttt iiiiit

RETURN VALUE

Upon successful completion a value of 0 is returned, otherwise an error will be returned. If a value other than the two legal values is used for *tag*, the function will return with an error, ERR1430_ILLEGAL_PASS_TAG. If *e1430_get_decimation_tag* is called to get the current parameter value of a group of HP E1430As and that parameter is not the same for all modules in the group, then the error, ERR1430_PARAMETER_UNEQUAL, is returned. The error, ERR1430_NO_GROUP, is returned if an illegal value of the *groupID* parameter is used (i.e. one that was not obtained by a call to *e1430_create_module_group(E1430)*).

SEE ALSO

e1430_create_module_group(E1430).

e1430_set_decimation_state **e1430_get_decimation_state**

Get or set extra level of decimation

SYNOPSIS

```
#include "e1430.h"
```

```
SHORTSIZ16 e1430_set_decimation_state(groupID, state);  
SHORTSIZ16 groupID;  
SHORTSIZ16 state;
```

```
SHORTSIZ16 e1430_get_decimation_state(groupID, *statePtr);  
SHORTSIZ16 groupID;  
SHORTSIZ16 *statePtr;
```

DESCRIPTION

E1430_set_decimation_state enables or disables an extra stage of decimation from the decimation filter in the HP E1430.

Note:

Calling this function while a measurement is running will force all HP E1430As in the group into the IDLE state.

GroupID is the group ID of a single HP E1430A or group of HP E1430As that was obtained by a call to *e1430_create_module_group*.

State selects additional decimation on the output of the decimation filter.

When this parameter is set to `E1430_DECIMATION_OFF` all samples from the decimation pass are saved. This results in oversampling by almost a factor of 2. Using `E1430_DECIMATION_ON` decimates by another factor of two in addition to the decimation bandwidth set by the either the *e1430_set_decimation_bandwidth* or *e1430_set_decimation_filter* functions. If this parameter is set to `E1430_DECIMATION_ON` when the bandwidth parameters for either the data or triggering is set to 24, this bandwidth parameter is reduced to 23. The total decimation bandwidth can not exceed 24.

RETURN VALUE

Upon successful completion a value of 0 is returned, otherwise an error will be returned. If a value other than the two legal values is used for *state*, the function will return with an error, `ERR1430_ILLEGAL_DECIMATE_MODE`. If the query function is called to get the current parameter value of a group of HP E1430As and that parameter is not the same for all modules in the group, then the error, `ERR1430_PARAMETER_UNEQUAL`, is returned. The error, `ERR1430_NO_GROUP`, is returned if an illegal value of the *groupID* parameter is used (i.e. one that was not obtained by a call to *e1430_create_module_group(E1430)*).

SEE ALSO

e1430_create_module_group(E1430), *e1430_set_decimation_filter(E1430)*,
e1430_set_decimation_state(E1430).

e1430_set_dsp_clock **e1430_get_dsp_clock**

Get and set DSP clock source

SYNOPSIS

```
#include "e1430.h"

SHORTSIZ16 e1430_get_dsp_clock(groupID, *sourcePtr);
SHORTSIZ16 groupID;
SHORTSIZ16 *sourcePtr;

SHORTSIZ16 e1430_set_dsp_clock(groupID, source);
SHORTSIZ16 groupID;
SHORTSIZ16 source;
```

DESCRIPTION

E1430_set_dsp_clock is used to configure the clocks used for decimation/zoom (DSP clock).

GroupID is the group ID of a single HP E1430A or group of HP E1430As that was obtained by a call to *e1430_create_module_group*.

Source selects the clock used to drive the decimation/zoom section within the HP E1430. It is not required to be the same as the ADC clock, although this is the normal case. When a slow external ADC clock is used, the signal processing and data transfers may be unnecessarily slowed down. To avoid this problem there is an option to run the DSP clock from a separate, faster source. The disadvantage of doing this is that specified analog performance will degrade due to spurious pickup by the sensitive analog hardware. Setting this parameter to `E1430_DSP_CLOCK_ADC` forces the DSP clock to be driven by the ADC clock. `E1430_DSP_CLOCK_INTERNAL` will cause the DSP clock to be the internally generated 10MHz oscillator. Note that the computed results will be the same in either case.

SourcePtr is a pointer to a memory location in which to return the current value of either the *adcClock* or *dspClock* parameter for an HP E1430A or a group of HP E1430As.

RETURN VALUE

Upon successful completion a value of 0 is returned, otherwise an error will be returned. Setting the *source* parameter to any value other than the two described above will cause the function to return the error, `ERR1430_ILLEGAL_DSP_CLOCK_SOURCE`. If the query function is called to get the current parameter value of a group of HP E1430As and that parameter is not the same for all modules in the group, then the error, `ERR1430_PARAMETER_UNEQUAL`, is returned. The error, `ERR1430_NO_GROUP`, is returned if an illegal value of the *groupID* parameter is used (i.e. one that was not obtained by a call to *e1430_create_module_group(E1430)*).

SEE ALSO

e1430_create_module_group(E1430).

e1430_set_input_high
e1430_get_input_high
e1430_set_input_low
e1430_get_input_low

Set or get state of input connection to ADC

SYNOPSIS

```
#include "e1430.h"

SHORTSIZ16 e1430_set_input_high(groupID, inHi);
SHORTSIZ16 groupID;
SHORTSIZ16 inHi;

SHORTSIZ16 e1430_get_input_high(groupID, inputPtr);
SHORTSIZ16 groupID;
SHORTSIZ16 *inputPtr;

SHORTSIZ16 e1430_set_input_low(groupID, inLo);
SHORTSIZ16 groupID;
SHORTSIZ16 inLo;

SHORTSIZ16 e1430_get_input_low(groupID, inputPtr);
SHORTSIZ16 groupID;
SHORTSIZ16 *inputPtr;
```

DESCRIPTION

E1430_set_input_high determines the source of the input signal to the Analog to Digital Converter. *E1430_set_input_low* determines the grounding state of the shield of the input connector.

GroupID is the group ID of a single E1430 or group of E1430s that was obtained by a call to *e1430_create_module_group*.

InHi selects the input to the ADC. E1430_INPUT_HI_CONN selects the *Analog Input* connector as the ADC input. E1430_INPUT_HI_GROUND grounds the ADC input.

InLo selects the grounding of the input connector shell.

E1430_INPUT_LO_FLOAT grounds the shell through a parallel combination of a 50 ohm resistor and a 0.04 uF capacitor. This provides sufficient impedance to suppress low frequency ground loop pickup. The maximum common mode voltage is limited to +/- .7 volts by a pair of 3 amp diodes.

E1430_INPUT_LO_GROUND grounds the connector shell to the chassis.

inputPtr is a pointer to a memory location in which to return the current value of the input high or low parameter for an HP E1430A or group of HP E1430As.

RETURN VALUE Upon successful completion a value of 0 is returned, otherwise an error will be returned. The set functions will return the error, `ERR1430_ILLEGAL_INPUT_SOURCE` if anything other than the legal values of the parameter are used. If a query function is called to get the current parameter value of a group of HP E1430As and that parameter is not the same for all modules in the group, then the error, `ERR1430_PARAMETER_UNEQUAL`, is returned. The error, `ERR1430_NO_GROUP`, is returned if an illegal value of the *groupID* parameter is used (i.e. one that was not obtained by a call to `e1430_create_module_group(E1430)`).

SEE ALSO `e1430_create_module_group(E1430)`.

e1430_set_input_offset **e1430_get_input_offset**

Set or get input offset voltage

SYNOPSIS

```
#include "e1430.h"

SHORTSIZ16 e1430_get_input_offset(la, *offsetPtr);
SHORTSIZ16 la;
FLOATSIZ64 *offsetPtr;

SHORTSIZ16 e1430_set_input_offset(la, offset);
SHORTSIZ16 la;
FLOATSIZ64 offset;
```

DESCRIPTION

E1430_set_input_offset will set the input offset DAC of an HP E1430.
E1430_get_input_offset reads the current offset value.

La is the logical address of a single HP E1430.

Offset is the offset as a signed fraction of the current range. This parameter is limited to -1.0 to +1.0, approximately.

OffsetPtr is a pointer to a memory location in which to return the current value of the input offset for an HP E1430.

RETURN VALUE

Upon successful completion a value of 0 is returned, otherwise an error will be returned.

e1430_set_interrupt
e1430_get_interrupt_mask
e1430_get_interrupt_priority
e1430_set_interrupt_mask
e1430_set_interrupt_priority

Set and query interrupt parameters

SYNOPSIS

```
#include "e1430.h"

SHORTSIZ16 get_interrupt_mask(groupID, intrNum, returnPtr);
SHORTSIZ16 groupID;
SHORTSIZ16 intrNum;
SHORTSIZ16 *returnPtr;

SHORTSIZ16 get_interrupt_priority(groupID, intrNum, returnPtr);
SHORTSIZ16 groupID;
SHORTSIZ16 intrNum;
SHORTSIZ16 *returnPtr;

SHORTSIZ16 set_interrupt(groupID, intrNum, priority, mask);
SHORTSIZ16 groupID;
SHORTSIZ16 intrNum;
SHORTSIZ16 priority;
SHORTSIZ16 mask;

SHORTSIZ16 set_interrupt_mask(groupID, intrNum, mask);
SHORTSIZ16 groupID;
SHORTSIZ16 intrNum;
SHORTSIZ16 mask;

SHORTSIZ16 set_interrupt_priority(groupID, intrNum, priority);
SHORTSIZ16 groupID;
SHORTSIZ16 intrNum;
SHORTSIZ16 priority;
```

DESCRIPTION

An HP E1430A has two independent interrupt generators, each capable of interrupting on one of the seven VME interrupt lines when a status condition specified by a mask occurs. *E1430_set_interrupt* sets the interrupt mask, priority and which of the two interrupt generators on the HP E1430A is to be used. The other functions set or query the mask and priority individually.

GroupID is the group ID of a single HP E1430A or group of HP E1430As that was obtained by a call to *e1430_create_module_group*.

IntrNum is the number of the interrupt generator. The only values accepted are 0 and 1; any other causes the function to return `ERR1430_ILLEGAL_INTR_NUMBER`.

Priority specifies which of the seven VME interrupt lines to use. The only legal values are 0 through 7. Specifying 0 turns the interrupt off, while 7 is the highest priority. Other values cause the function to return ERR1430_ILLEGAL_INTR_PRIORITY.

Mask specifies the mask of events on which to interrupt. This mask is created by ORing together the bits defined in the following table:

Interrupt Mask Bit Definitions

Define	Description
E1430_INTR_READ_VALID	At least one data word in FIFO
E1430_INTR_BLOCK_READY	Block of data ready in FIFO
E1430_INTR_MODULE_ARMED	E1430 armed and waiting for trigger
E1430_INTR_MEAS_DONE	E1430 has stopped taking new data
E1430_INTR_INPUT_OVERLOAD	Input has exceeded range
E1430_INTR_ADC_ERROR	Hardware fault in ADC

Any value other than those in the table will cause the function to return the error, ERR1430_ILLEGAL_INTR_MASK.

ReturnPtr is a pointer to a memory location in which to return the current value of the either the interrupt mask or priority parameter for a group of HP E1430As.

RETURN VALUE

Upon successful completion a value of 0 is returned by all functions. Otherwise an error will be returned. The error values returned because of an illegally specified parameter are described above. If a query function is called to get the current parameter value of a group of HP E1430As and that parameter is not the same for all modules in the group, then the error, ERR1430_PARAMETER_UNEQUAL, is returned. The error, ERR1430_NO_GROUP, is returned if an illegal value of the *groupID* parameter is used.

SEE ALSO

e1430_create_module_group(E1430).

e1430_set_lbus_mode **e1430_get_lbus_mode**

Get and set local bus mode

SYNOPSIS

```
#include "e1430.h"

SHORTSIZ16 e1430_get_lbus_mode(la, returnPtr);
SHORTSIZ16 la;
SHORTSIZ16 *returnPtr;
SHORTSIZ16 e1430_set_lbus_mode(la, lbusMode);
SHORTSIZ16 la;
SHORTSIZ16 lbusMode;
```

DESCRIPTION

E1430_set_lbus_mode sets the local bus to either generate, append, insert or pipeline data. The data port must be set to the local bus with the *e1430_set_data_port* function before these modes take effect.

La is the logical address of a single HP E1430.

LbusMode selects the transmission mode of the local bus when it is enabled by the *e1430_set_data_port* function. E1430_LBUS_GENERATE forces the module at *la* to generate data only, not passing through data from other modules on the local bus. E1430_LBUS_APPEND causes the HP E1430A to pass through data from modules on its left and append its data to the end. E1430_LBUS_INSERT causes the HP E1430A to place its data on the local bus and then pass through data from modules on its left. E1430_LBUS_PIPELINE causes the HP E1430A to pipe data through from modules on its left without appending or inserting its own data. The state of this parameter is unaffected by switching back and forth between the local bus and the VME backplane with the *e1430_set_port* function. The default state is E1430_LBUS_GENERATE.

ReturnPtr is a pointer to a memory location into which to return the current value of the local bus mode.

RETURN VALUE

Upon successful completion a value of 0 is returned by all functions. Otherwise an error will be returned. If a value of *lbusMode* other than those described above is specified, the error, ERR1430_ILLEGAL_LBUS_MODE, is returned. If an HP E1430A is not present at the logical address, the error, ERR1430_NO_MOD_AT_LA, is returned.

SEE ALSO

e1430_set_data_port(E1430)

e1430_set_multi_sync **e1430_get_multi_sync**

Get and set multi sync mode

SYNOPSIS

```
#include "e1430.h"

SHORTSIZ16 e1430_get_multi_sync(groupID, *statePtr);
SHORTSIZ16 groupID;
SHORTSIZ16 *statePtr;

SHORTSIZ16 e1430_set_multi_sync(groupID, syncState);
SHORTSIZ16 groupID;
SHORTSIZ16 syncState;
```

DESCRIPTION

The HP E1430A supports synchronous operation among multiple HP E1430As by using an ECL line on the VXI backplane to drive all the modules in a system from the same clock. *E1430_set_multi_sync* is used to specify whether the ADC clock and sync is generated locally or is taken from the backplane.

Note:

If an entire group is put into multi-sync mode, one HP E1430A must have previously been set up as a clock master OR an external clock must be applied to the Mainframe extender ECL CLOCK connector. OTHERWISE, serious communications problems will occur with bus errors and measurement timeouts being returned from most e1430 commands.

To synchronize the phase of the local oscillators for a zoomed measurement, the *e1430_reset_dsp* function must also be called. See *e1430_set_clock_master_mode* for an example of setting up multi-module synchronous groups.

GroupID is the group ID of a single HP E1430A or group of HP E1430As that was obtained by a call to *e1430_create_module_group*.

SyncState set to E1430_MULTI_SYNC_OFF causes the ADC clock and SYNC to be generated locally. If *syncState* is set to E1430_MULTI_SYNC_ON the module uses the ADC clock distributed on the VXI backplane, overriding the selection made by a call to the *e1430_set_adc_clock* function. This mode also uses the backplane SYNC line for multi-module synchronization capabilities including: arming, triggering, initialization of the zoom local oscillator phase, and decimation.

StatePtr is a pointer to a memory location which is used to return the current value of the *syncState* parameter for an HP E1430A or group of HP E1430As.

RETURN VALUE Upon successful completion a value of 0 is returned, otherwise an error will be returned. Setting the *syncState* parameter to an illegal value will cause the function to return the error, ERR1430_ILLEGAL_MULTI_SYNC_MODE. If *e1430_get_multi_sync* is called to get the current parameter value of a group of HP E1430As and that parameter is not the same for all modules in the group, then the error, ERR1430_PARAMETER_UNEQUAL, is returned. The error, ERR1430_NO_GROUP, is returned if an illegal value of the *groupID* parameter is used (i.e. one that was not obtained by a call to *e1430_create_module_group(E1430)*).

SEE ALSO *e1430_create_module_group(E1430)*, *e1430_set_adc_clock(E1430)*, *e1430_reset_dsp(E1430)*.

e1430_set_range
e1430_get_range
e1430_set_range_la
e1430_get_range_la

Get or set range

SYNOPSIS

```
#include "e1430.h"

SHORTSIZ16 e1430_set_range(groupID, range);
SHORTSIZ16 groupID;
FLOATSIZ64 range;

SHORTSIZ16 e1430_get_range(groupID, rangePtr);
SHORTSIZ16 groupID;
FLOATSIZ64 *rangePtr;

SHORTSIZ16 e1430_set_range_la(la, range);
SHORTSIZ16 la;
FLOATSIZ64 range;

SHORTSIZ16 e1430_get_range_la(la, rangePtr);
SHORTSIZ16 la;
FLOATSIZ64 *rangePtr;
```

DESCRIPTION

E1430_set_range will set the range of a group of HP E1430As.
E1430_set_range_la will set the range of a single HP E1430.

GroupID is the group ID of a single E1430 or group of E1430s that was obtained by a call to *e1430_create_module_group*.

La is the logical address of a single E1430.

Range is the full scale range in volts. Signal inputs whose absolute value is larger than full scale will generate an ADC overflow error. The discrete legal values of *range* vary between 0.0078125 and 8.0 volts by powers of two. The actual range that is set will be the nearest legal range value that is greater than or equal to the value specified by the *range* parameter. If a value is specified that is greater than the maximum range, the range is set to the maximum, 8.0 volts.

RangePtr is a pointer to a memory location in which to return the current value of the range parameter for an E1430 or group of E1430s.

RETURN VALUE Upon successful completion a value of 0 is returned by all functions. Otherwise an error will be returned. If *e1430_get_range* is called to get the current parameter value of a group of E1430s and that parameter is not the same for all modules in the group, then the error, ERR1430_PARAMETER_UNEQUAL, is returned. The error, ERR1430_NO_GROUP, is returned if an illegal value of the *groupID* parameter is used (i.e. one that was not obtained by a call to *e1430_create_module_group(E1430)*). If there is no E1430 at the logical address given by the *la* parameter, the error, ERR1430_NO_MOD_AT_LA will be returned.

SEE ALSO *e1430_create_module_group(E1430)*.

e1430_set_sample_clock_freq_la **e1430_get_sample_clock_freq_la**

Get and set sample clock frequency

SYNOPSIS

```
#include "e1430.h"

SHORTSIZ16 e1430_get_sample_clock_freq_la(la, *freqPtr);
SHORTSIZ16 la;
FLOATSIZ64 *freqPtr;

SHORTSIZ16 e1430_set_sample_clock_freq_la(la, freq);
SHORTSIZ16 la;
FLOATSIZ64 freq;
```

DESCRIPTION

E1430_set_sample_clock_freq_la is used to set the frequency of an external sampling clock. *E1430_get_sample_clock_freq_la* returns the current sample clock frequency.

La is the logical address of a single E1430.

Freq sets the frequency of an external sample clock connected to the ExtClk TTL connector. When the source of the ADC clock is set to an external clock by the *e1430_set_adc_clock* function, the value specified by *freq* will be used in any calculations involving sample frequency. This value has no effect if the module is set up to use the internal ADC clock.

FreqPtr is a pointer to a memory location in which to return the current value of the sample clock frequency. If the E1430 is set to the internal ADC clock, the value of that clock frequency is returned. If the E1430 is set to the external clock, the last value entered via the *e1430_set_sample_clock_freq_la* function is returned.

RETURN VALUE

Upon successful completion a value of 0 is returned by all functions, otherwise an error will be returned. If there is no E1430 at the logical address given by the *la* parameter, the error, ERR1430_NO_MOD_AT_LA will be returned.

SEE ALSO

e1430_set_adc_clock(E1430).

e1430_set_span_zoom **e1430_get_span**

Set and get center frequency, span and zoom

SYNOPSIS

```
#include "e1430.h"
```

```
SHORTSIZ16 e1430_set_span_zoom(groupID, frequency, span, zoom)
SHORTSIZ16 groupID;
FLOATSIZ64 frequency;
FLOATSIZ64 span;
SHORTSIZ16 zoom;
```

```
SHORTSIZ16 e1430_get_span(groupID, spanPtr)
SHORTSIZ16 groupID;
FLOATSIZ64 *spanPtr;
```

DESCRIPTION

E1430_set_span_zoom sets the center frequency, span and zoom in one function. This function is included in the E1430 library to be backward compatible with the method of setting zoom parameters in the HP3665 product. *E1430_get_span* returns the current span. These functions will affect the decimation bandwidth and decimation state parameters set by the *e1430_set_decimation_filter* function.

GroupID is the group ID of a single E1430 or group of E1430s that was obtained by a call to *e1430_create_module_group*.

Frequency is the frequency in Hz for the center frequency. This parameter is ignored when *zoom* is set to E1430_ZOOM_OFF.

Span is the alias protected width of the decimation filter in hertz. This is the width at which aliased frequencies are suppressed by at least 80dB. Span is set in discrete steps that go as powers of two. Reducing the span also causes decimation of the samples in the decimation filter, thereby reducing the output sample rate. The legal spans and their relationship to output sample rate is given by the following formulas:

Zoom off: $\text{span} = F_s / (2.56 * 2^N)$ output sample rate = $F_s / (2^N)$

Zoom on: $\text{span} = F_s / (1.28 * 2^N)$ output sample rate = $F_s / (2^N)$

where $N = 0$ to 23.

In the baseband case (zoom off) span represents the width of decimation filter above zero frequency. In the zoomed case span represents the width of the decimation filter centered on the center frequency.

Zoom turns zoom on/off. E1430_ZOOM_ON turns it on, E1430_ZOOM_OFF turns it off. Turning zoom on sets the output data type to complex, while turning zoom off sets this data type to real.

Note:

When using the Local Bus, it is necessary to reset the local bus after setting the center frequency because data can be flushed into the Local Bus pipeline by this function call. See documentation under *e1430_reset_lbus()*.

RETURN VALUE

Upon successful completion a value of 0 is returned, otherwise an error will be returned.

e1430_set_timeout **e1430_get_timeout**

Get and set I/O timeout value

SYNOPSIS

```
#include "e1430.h"

SHORTSIZ16 e1430_get_timeout(returnPtr);
LONGSIZ32 *returnPtr;

SHORTSIZ16 e1430_set_timeout(timeout);
LONGSIZ32 timeout;
```

DESCRIPTION

E1430_set_timeout sets the timeout involved in I/O operations that wait for the change of a status bit or the state of the SYNC line. *E1430_get_timeout* queries the current value of the timeout. The default value is 5.0 seconds.

Timeout is in seconds.

ReturnPtr is a pointer to a memory location in which to return the current value of the *timeout* parameter in seconds for an E1430 or group of E1430s.

RETURN VALUE

All other functions return a value of 0 when successful. Otherwise an error will be returned.

e1430_set_trigger_delay **e1430_get_trigger_delay**

Set and get trigger delay

SYNOPSIS

```
#include "e1430.h"

SHORTSIZ16 e1430_get_trigger_delay(groupID, delayPtr);
SHORTSIZ16 groupID;
SHORTSIZ16 *delayPtr;

SHORTSIZ16 e1430_set_trigger_delay(groupID, delay);
SHORTSIZ16 groupID;
LONGSIZ32 delay;
```

DESCRIPTION

e1430_set_trigger_delay sets the delay between the trigger event and the first data point in the data block.

GroupID is the group ID of a single E1430 or group of E1430s that was obtained by a call to *e1430_create_module_group*.

Delay is the time delay in units of output samples between when a trigger is received and the first data point in the data block. Negative values indicate a pre-trigger condition, where samples prior to the trigger event are included in the data block.

In the E1430 hardware, the delay can only be set in integral multiples of 8 bytes of data. Depending on sample size, this means *delay* could be rounded to the nearest integer that is divisible by the number of samples in 8 bytes. Always query the delay after it is set with the *e1430_get_trigger_delay* to get the actual delay. A more accurate value of delay can be determined by adding a correction returned by the function, *e1430_get_trigger_delay*. The following table relates sample size, granularity of the *delay* parameter and range of values of the *delay* parameter. FIFOSIZE is the size of the FIFO memory in bytes.

Data Type	Granularity	Range
Real 16	4	-FIFOSIZE/2 to +33,554,431
Complex 16	2	-FIFOSIZE/4 to +16,777,215
Real 32	2	-FIFOSIZE/4 to +16,777,215
Complex 32	1	-FIFOSIZE/8 to 8,388,607

Note:

The trigger delay is set in number of output sample periods, not sample clock periods. This means that if the decimation filter is on, the output sample period is less than the sample clock period. See *e1430_set_decimation_filter* to determine the output sample rate.

To calculate the exact trigger delay to the resolution of one sample clock period, use the function *e1430_get_trigger_phase* to get a correction factor due to this FIFO packing and variable filter delays.

DelayPtr is a pointer to a memory location in which to return the current value of the trigger delay associated with triggering for an E1430 or group of E1430s.

RETURN VALUE

Upon successful completion a value of 0 is returned, otherwise an error will be returned. If *e1430_get_trigger_delay* is called to get the current parameter value of a group of E1430s and that parameter is not the same for all modules in the group, then the error, ERR1430_PARAMETER_UNEQUAL, is returned. The error, ERR1430_NO_GROUP, is returned if an illegal value of the *groupID* parameter is used (i.e. one that was not obtained by a call to *e1430_create_module_group(E1430)*).

SEE ALSO

e1430_create_module_group(E1430), *e1430_set_decimation_bandwidth(E1430)*, *e1430_set_decimation_filter(E1430)*, *e1430_get_trigger_phase(E1430)*.

e1430_set_trigger_level_adc **e1430_get_trigger_level_adc**

Set and get trigger level for ADC triggering

SYNOPSIS

```
#include "e1430.h"
```

```
SHORTSIZ16 e1430_get_trigger_level_adc(groupID, returnPtr);  
SHORTSIZ16 groupID;  
FLOATSIZ64 *returnPtr;
```

```
SHORTSIZ16 e1430_set_trigger_level_adc(groupID, level);  
SHORTSIZ16 groupID;  
FLOATSIZ64 level;
```

DESCRIPTION

E1430_set_trigger_level_adc set the trigger level for the ADC triggering mode. It can be set at any time, but is only effective when in the ADC triggering mode.

GroupID is the group ID of a single E1430 or group of E1430s that was obtained by a call to e1430_create_module_group.

Level is the triggering signal threshold expressed as a fraction of full scale of the current range (-1.0 to 1.0). There is hysteresis around the threshold in order to prevent multiple triggers from a single threshold crossing.

ReturnPtr is a pointer to a memory location in which to return the current value of the of the ADC trigger level for an E1430 or group of E1430s.

RETURN VALUE

Upon successful completion a value of 0 is returned, otherwise an error will be returned. If an illegal value of the *level* parameter is specified, the error, ERR1430_TRIG_LIN_LEVEL_RANGE, is returned. If *e1430_get_trigger_level_mag* is called to get the current ADC level value of a group of E1430s and that parameter is not the same for all modules in the group, then the error, ERR1430_PARAMETER_UNEQUAL, is returned. The error, ERR1430_NO_GROUP, is returned if an illegal value of the *groupID* parameter is used (i.e. one that was not obtained by a call to *e1430_create_module_group(E1430)*).

SEE ALSO

e1430_create_module_group(E1430)

e1430_set_trigger_level_mag **e1430_get_trigger_level_mag**

Get and set trigger level for magnitude triggering mode

SYNOPSIS

```
#include "e1430.h"

SHORTSIZ16 e1430_get_trigger_level_mag(groupID, returnPtr);
SHORTSIZ16 groupID;
FLOATSIZ64 *returnPtr;

SHORTSIZ16 e1430_set_trigger_level_mag(groupID, level);
SHORTSIZ16 groupID;
FLOATSIZ64 level;
```

DESCRIPTION

e1430_set_trigger_level_mag set the level for triggering for the magnitude triggering mode. It can be set at any time, but is effective only when in the magnitude trigger mode. The magnitude triggering level is a fraction of the full scale magnitude of the complex output of the decimation filter.

GroupID is the group ID of a single E1430 or group of E1430s that was obtained by a call to *e1430_create_module_group*.

level is used to set the triggering signal threshold in the magnitude mode of triggering and is expressed as dBs from full scale (+3.0 to -85.0). There is hysteresis around the threshold in order to prevent multiple triggers from a single threshold crossing.

ReturnPtr is a pointer to a memory location in which to return the current value of the of the magnitude triggering level associated with an E1430 or group of E1430s.

RETURN VALUE

Upon successful completion a value of 0 is returned, otherwise an error will be returned. The error value returned because of an illegal value for the *level* parameter is ERR1430_TRIG_LOG_LEVEL_RANGE. If *e1430_get_trigger_level_mag* is called to get the current parameter value of a group of E1430s and that parameter is not the same for all modules in the group, then the error, ERR1430_PARAMETER_UNEQUAL, is returned. The error, ERR1430_NO_GROUP, is returned if an illegal value of the *groupID* parameter is used (i.e. one that was not obtained by a call to *e1430_create_module_group(E1430)*).

SEE ALSO

e1430_create_module_group(E1430)

e1430_set_trigger_mode

Set all triggering parameters.

SYNOPSIS

```
#include "e1430.h"

SHORTSIZ16 e1430_set_trigger_mode(groupID, source, delay, level, slope);
SHORTSIZ16 groupID;
SHORTSIZ16 source;
LONGSIZ32 delay;
FLOATSIZ64 level;
SHORTSIZ16 slope;
```

DESCRIPTION

E1430_set_trigger_mode is the function that sets all trigger parameters at once, except the trigger bandwidth of the decimation filter. There are also functions to set the individual parameters associated with triggering. An E1430 will generate a trigger only when it is in the TRIGGER state and the SYNC line on the VXI backplane is high. When a trigger is generated, the E1430 generating the trigger will pull the SYNC line low.

GroupID is the group ID of a single E1430 or group of E1430s that was obtained by a call to *e1430_create_module_group*.

Source determines the trigger source.

E1430_TRIGGER_SOURCE_OFF will disable trigger generation.

E1430_TRIGGER_SOURCE_AUTO will cause trigger generation immediately upon entering the TRIGGER state.

E1430_TRIGGER_SOURCE_EXT will cause trigger generation when an E1430 is in the TRIGGER state of the measurement loop, the backplane SYNC line is high and a transition specified by the *slope* parameter is encountered on the TTL external trigger input connector.

E1430_TRIGGER_SOURCE_ADC is similar to the external mode except that triggers are generated when the ADC signal crosses the voltage level set by *level* with a slope set by *slope*.

E1430_TRIGGER_SOURCE_MAG is similar to the ADC mode except that the signal used is the magnitude of the complex output of the decimation filter instead of the ADC signal.

An illegal value for the *source* parameter will result in the function returning the error, ERR1430_ILLEGAL_TRIG_MODE.

Delay is the time delay in units of output samples between when a trigger is received and the first data point in the data block. Negative values indicate a pre-trigger condition, where samples prior to the trigger event are included in the data block.

In the E1430 hardware, the delay can only be set in integral multiples of 8 bytes of data. Depending on sample size, this means *delay* could be rounded to the nearest integer that is divisible by the number of samples in 8 bytes. Always query the delay after it is set with the *e1430_get_trigger_delay* function.

A more accurate value of delay can be determined by getting a correction factor from function, *e1430_get_trigger_delay*. The following table relates sample size, granularity of the *delay* parameter and range of values of the *delay* parameter. FIFOSIZE is the size of the FIFO memory in bytes.

Data Type	Granularity	Range
Real 16	4	-FIFOSIZE/2 to +33,554,431
Complex 16	2	-FIFOSIZE/4 to +16,777,215
Real 32	2	-FIFOSIZE/4 to +16,777,215
Complex 32	1	-FIFOSIZE/8 to 8,388,607

Note:

The trigger delay is set in number of output sample periods, not sample clock periods. This means that if the decimation filter is on, the output sample period is less than the sample clock period. See *e1430_set_decimation_filter* to determine output sample rate.

To calculate the exact trigger delay with a resolution of one input sample period, use the *e1430_get_trigger_phase* function.

Level is used to set the triggering signal threshold in the E1430_TRIGGER_SOURCE_ADC and E1430_TRIGGER_SOURCE_MAG modes. This threshold is expressed as a fraction of full scale (-1.0 to 1.0) in the E1430_TRIGGER_SOURCE_ADC mode, and as dBs from full scale (+3.0 to -85.0) in the E1430_TRIGGER_SOURCE_MAG mode. This parameter is ignored for the E1430_TRIGGER_SOURCE_EXT mode. There is hysteresis around the threshold in order to prevent multiple triggers from a single threshold crossing. An illegal value for the *level* parameter will cause the function to return one of the errors, ERR1430_TRIG_LIN_LEVEL_RANGE or ERR1430_TRIG_LOG_LEVEL_RANGE, depending on the *source* parameter.

Slope selects the edge of the trigger source on which trigger occurs. E1430_TRIGGER_SLOPE_POS sets triggering on the positive slope and E1430_TRIGGER_SLOPE_NEG on the negative slope. An illegal value for *slope* causes the function to return ERR1430_ILLEGAL_TRIGGER_SLOPE.

HP E1430A User's Guide
e1430_set_trigger_mode

RETURN VALUE

Upon successful completion a value of 0 is returned, otherwise an error will be returned. The error values returned because of an illegally specified parameter are described above. The error, ERR_NO_GROUP, is returned if an illegal value of the *groupID* parameter is used (i.e. one that was not obtained by a call to *e1430_create_module_group(E1430)*).

SEE ALSO

e1430_create_module_group(E1430), e1430_set_decimation_bandwidth(E1430), e1430_set_decimation_filter(E1430).

e1430_set_trigger_slope **e1430_get_trigger_slope**

Get and set trigger slope

SYNOPSIS

```
#include "e1430.h"

SHORTSIZ16 e1430_get_trigger_slope(groupID, returnPtr);
SHORTSIZ16 groupID;
FLOATSIZ64 *returnPtr;

SHORTSIZ16 e1430_set_trigger_slope(groupID, slope);
SHORTSIZ16 groupID;
SHORTSIZ16 slope;
```

DESCRIPTION

E1430_set_trigger_slope sets whether triggering occurs on the positive or negative slope of either the ADC output or the magnitude of the complex output of the decimation filter.

GroupID is the group ID of a single E1430 or group of E1430s that was obtained by a call to *e1430_create_module_group*.

Slope selects the edge of the trigger source on which trigger occurs. E1430_TRIGGER_SLOPE_POS sets triggering on the positive slope and E1430_TRIGGER_SLOPE_NEG on the negative slope.

ReturnPtr is a pointer to a memory location in which to return the current value of the of the trigger slope associated an E1430 or group of E1430s.

RETURN VALUE

Upon successful completion a value of 0 is returned, otherwise an error will be returned. An illegal value returns ERR1430_ILLEGAL_TRIGGER_SLOPE. If *e1430_get_trigger_slope* is called to get the current parameter value of a group of E1430s and that parameter is not the same for all modules in the group, then the error, ERR1340_PARAMETER_UNEQUAL, is returned. The error, ERR1340_NO_GROUP, is returned if an illegal value of the *groupID* parameter is used (i.e. one that was not obtained by a call to *e1430_create_module_group*(E1430)).

SEE ALSO

e1430_create_module_group(E1430), *e1430_set_trigger_source*(E1430).

e1430_set_trigger_source **e1430_get_trigger_source**

Get and set trigger source

SYNOPSIS

```
#include "e1430.h"
```

```
SHORTSIZ16 e1430_get_trigger_source(groupID, returnPtr);  
SHORTSIZ16 groupID;  
FLOATSIZ64 *returnPtr;
```

```
SHORTSIZ16 e1430_set_trigger_source(groupID, source);  
SHORTSIZ16 groupID;  
SHORTSIZ16 source;
```

DESCRIPTION

E1430_set_trigger_source sets the source for trigger generation. When an E1430 is enabled to generate triggers, it will pull the SYNC line on the VXI backplane when its trigger conditions are satisfied. All other E1430s that are in the TRIGGER state will exit the this state and enter the MEAS state when the SYNC line is pulled.

GroupID is the group ID of a single E1430 or group of E1430s that was obtained by a call to *e1430_create_module_group*.

Source determines the source of the trigger generation.

E1430_TRIGGER_SOURCE_OFF will disable trigger generation altogether.

E1430_TRIGGER_SOURCE_AUTO will cause trigger generation immediately upon entering the TRIGGER state.

E1430_TRIGGER_SOURCE_EXT will cause trigger generation when an E1430 is in the TRIGGER state of the measurement loop, the backplane SYNC line is high and a transition specified by the programmed trigger slope is encountered on the TTL external trigger input connector.

E1430_TRIGGER_SOURCE_ADC is similar to the external mode except that triggers are generated when the ADC signal crosses the voltage level and slope programmed by the *e1430_set_trigger_level_adc* and *e1430_set_trigger_slope*, respectively.

E1430_TRIGGER_SOURCE_MAG is similar to the ADC mode except that the signal used is the magnitude of the complex output of the decimation filter instead of the ADC signal. The trigger level in this case is set by the *e1430_set_trigger_level_mag* function.

ReturnPtr is a pointer to a memory location in which to return the current value of the trigger source associated with an E1430 or group of E1430s.

RETURN VALUE Upon successful completion a value of 0 is returned, otherwise an error will be returned. An illegal value for the *source* parameter will result in the function returning the error, ERR1430_ILLEGAL_TRIG_MODE. If *e1430_get_trigger_source* is called to get the current parameter value of a group of E1430s and that parameter is not the same for all modules in the group, then the error, ERR1430_PARAMETER_UNEQUAL, is returned. The error, ERR1430_NO_GROUP, is returned if an illegal value of the *groupID* parameter is used (i.e. one that was not obtained by a call to *e1430_create_module_group(E1430)*).

SEE ALSO *e1430_create_module_group(E1430)*, *e1430_set_trigger_level_adc(E1430)*, *e1430_set_trigger_level_mag(E1430)*, *e1430_set_trigger_slope(E1430)*.

e1430_trigger_module

Trigger module by software control

SYNOPSIS

```
#include "e1430.h"
```

```
SHORTSIZ16 e1430_trigger_module(groupID)  
SHORTSIZ16 groupID;
```

DESCRIPTION

E1430_trigger_module allows program controlled triggering of a group of E1430s. The function waits for all E1430s in the group to be in the TRIGGER state and then moves them all into the MEAS state.

GroupID is the group ID of a single E1430 or group of E1430s that was obtained by a call to *e1430_create_module_group*.

RETURN VALUE

Upon successful completion a value of 0 is returned. Otherwise an error will be returned. The error, ERR1430_NO_GROUP, is returned if an illegal value of the *groupID* parameter is used (i.e. one that was not obtained by a call to *e1430_create_module_group(E1430)*).

SEE ALSO

e1430_create_module_group(E1430)

e1430_write_register
e1430_write_register_card
e1430_write_register_image
e1430_read_register_card
e1430_read_register_image

Low level register reads and writes.

SYNOPSIS

```
#include "e1430.h"

SHORTSIZ16 e1430_read_register_card(la, reg, dataPtr);
SHORTSIZ16 la;
SHORTSIZ16 reg;
SHORTSIZ16 *dataPtr;

SHORTSIZ16 e1430_read_register_image(la, reg, dataPtr);
SHORTSIZ16 la;
SHORTSIZ16 reg;
SHORTSIZ16 *dataPtr;

SHORTSIZ16 e1430_write_register(groupID, reg, data);
SHORTSIZ16 groupID;
SHORTSIZ16 reg;
SHORTSIZ16 data;

SHORTSIZ16 e1430_write_register_card(la, reg, data);
SHORTSIZ16 la;
SHORTSIZ16 reg;
SHORTSIZ16 data;

SHORTSIZ16 e1430_write_register_image(la, reg, data);
SHORTSIZ16 la;
SHORTSIZ16 reg;
SHORTSIZ16 data;
```

DESCRIPTION

E1430_write_register will write the same data to a particular register in all E1430s in a group. It writes data to both the E1430 register and the internal register image.

E1430_write_register_card will write data to a particular register on a single E1430 located at logical address, *la*.

Note:

This function does not update the register image, use *write_register_image* to insure that the E1430's images are maintained correctly.

E1430_write_register_image will write data to a particular register on a single E1430 located at logical address, *la*. In addition, it will update the image of this register, if the register has an internal image.

E1430_read_register_card will read the contents of a register on a single E1430 located at logical address, *la*.

E1430_read_register_image will read the contents of a register image for the module located at logical address, *la*.

Note:

The functions above all trap bus errors that might occur while reading or writing a register, and return the error, ERR1430_BUS_ERROR, if a bus error occurs.

GroupID is the group ID of a single E1430 or group of E1430s that was obtained by a call to *e1430_create_module_group*.

La is the logical address of a single E1430.

Reg is the offset of the register relative to the base address of the E1430 (i.e. E1430_VXI_ID_REG = 0).

DataPtr is a pointer to a memory location in which to return the current value of the data contained in a register.

RETURN VALUE

Upon successful completion a value of 0 is returned by all functions. Otherwise an error will be returned. ERR1430_NO_GROUP, is returned if an illegal value of the *groupID* parameter is used (i.e. one that was not obtained by a call to *e1430_create_module_group(E1430)*). If there is no E1430 at the logical address given by the *la* parameter, the error, ERR1430_NO_MOD_AT_LA will be returned.

SEE ALSO

e1430_create_module_group(E1430).

Errors

Error Number	Description
1000	Error number returned is out of bounds
1001	Unable to malloc an internal data structure
1002	Unable to realloc an internal data structure
1003	Unable to create an internal module state
1004	No E1430 at specified logical address
1005	Invalid group ID parameter
1006	Illegal timing setup multi-sync state parameter
1007	Illegal timing setup ADC clock source parameter
1008	Illegal timing setup DSP clock source parameter
1009	Illegal data output port parameter
1010	Illegal decimate filter pass tag parameter
1011	Illegal data block append status parameter
1012	Illegal data type parameter
1013	Illegal data size parameter
1014	Blocksize parameter out of range
1015	Illegal decimate output parameter
1016	Illegal decimation state parameter
1017	Illegal anti-alias filter state parameter
1018	Range parameter out of range
1019	Illegal analog input source parameter
1020	Illegal data mode parameter
1021	Error returned by operating system on a VXI trigger line state query
1022	Illegal analog input coupling parameter
1023	Illegal triggering mode parameter
1024	Illegal triggering slope parameter
1025	ADC trigger level parameter out of range
1026	Magnitude trigger level parameter out of range
1027	Pre-trigger delay exceeds FIFO size
1028	Illegal VXI register number parameter
1029	Illegal interrupt number parameter
1030	Illegal interrupt priority parameter
1031	Illegal interrupt mask parameter
1032	Decimate bandwidth parameter out of range

Error Number	Description
1033	Timeout waiting for SYNC line to change state
1034	Attempt to assign 2 clock masters in one mainframe
1035	Illegal SYNC line state parameter
1036	Unable to map register addresses into current process
1037	Unable to open SICL device for E1430
1038	E1430 at logical address not in a group
1039	E1430s not in contiguous slots for local bus
1040	Parameter value not equal for all E1430 in the group
1041	Magnitude trigger bandwidth out of range
1042	Timeout waiting for trigger
1043	Timeout waiting for arm
1044	Timeout waiting for data ready in status register
1045	Illegal combination data/trigger filter bandwidths
1046	ADC error collecting last block of data
1047	Input signal exceeds maximum range
1048	Can't open statefile specified
1049	Can't read statefile specified
1050	Can't write to statefile specified
1051	Can't close statefile specified
1052	Specified file is not a statefile
1053	Logical address in state file does not match that of internal state
1054	Error trying to read system timer
1055	Bus error during register access
1056	Illegal clock master mode
1057	Local Bus not supported in this environment
1058	Logical address decoding error during diagnostics
1059	Timeout on read request during diagnostics
1060	Illegal response to D32 read request during diagnostics
1061	Timeout on D8 read request during diagnostics
1062	Illegal response to unaligned D16 read request during diagnostics
1063	Illegal response to A24 read request during diagnostics
1064	Illegal response to A32 read request during diagnostics
1065	Incorrect response to register read during diagnostics
1066	Illegal response to register write during diagnostics
1067	Timeout on register write during diagnostics
1068	Illegal response to register read during diagnostics

Error Number	Description
1069	No response to DSP chip read during diagnostics
1070	Incorrect read/write of Port Control Register during diagnostics
1071	Can't read/write of Port Control Register during diagnostics
1072	Illegal write during reset during diagnostics
1073	Can't reset module during diagnostics
1074	Can't read/write Timing Setup Register during diagnostics
1075	Can't read VXI Status Register during diagnostics
1076	Improper DSP clock present during diagnostics
1077	ADC clock missing during diagnostics
1078	Improper ADC clock present during diagnostics
1079	DSP clock missing during diagnostics
1080	16-bit real data error during diagnostics
1081	16-bit complex data error during diagnostics
1082	32-bit real data error during diagnostics
1083	32-bit complex data error during diagnostics
1084	Error saving or tagging multipass data during diagnostics
1085	Error data decimation pattern for multipass data during diagnostics
1086	Error in 24-bit passtag for multipass data during diagnostics
1087	Incorrect status byte appended to data during diagnostics
1088	No status byte appended to data during diagnostics
1089	Incorrect exit of IDLE state during diagnostics
1090	Failed to enter TRIGGER state properly during diagnostics
1091	Failed to enter MEAS state properly during diagnostics
1092	Failed to enter IDLE state properly during diagnostics
1093	Failed to enter ARM state properly during diagnostics
1094	Failed to auto trigger properly during diagnostics
1095	Failed FIFO memory test during diagnostics
1096	Illegal trigger delay value
1097	Auto zero failure
1098	Extra words in data block
1099	Selftest failure to reset DSP section
1100	Fails call to SICL ivxirminfo function
1101	Unexpected interrupt
1102	Missing ARMED interrupt
1103	Missing READ_VALID interrupt
1104	Missing BLOCK_READY interrupt

Error Number	Description
1105	Missing MEAS_DONE interrupt
1106	Incorrect interrupt status
1107	No interrupt lines allocated to this device
1108	Failure to install interrupt handler
1109	Failure to enable interrupt handler
1110	IOCTL failure
1111	Failure while reading keyboard
1112	Offset DAC out of range in trigger diagnostics
1113	Illegal exit of TRIG state in trigger diagnostics
1114	Failure to exit TRIG state in trigger diagnostics
1115	Wrong trigger delay in trigger diagnostics
1116	Triggered on wrong slope in trigger diagnostics
1117	Failed to trigger in slope trigger mode in trigger diagnostics
1118	Reread failure
1119	Illegal LBUS mode
1120	Illegal LBUS reset state
1121	Sample clock frequency not equal for module group
1122	Illegal data reread state
1123	Logical address used in function requiring group ID
1124	The module group referenced must be a synchronous group
1125	No clock master has been specified for the module group
1126	ADC Error or ADC Overload bits not being set properly
1127	Illegal clock value
1128	Illegal filter value 0 - 1
1129	Illegal buffer size 1
1130	Illegal resample output ratio .25 - 1000

11

SCPI Overview and Commands

Introduction to SCPI

What is SCPI?

SCPI—the Standard Commands for Programmable Instruments—is a programming language designed specifically for controlling instruments. It defines how you communicate with these instruments from an external controller (computer).

History

Computer-controlled test instruments that were introduced in the 1960s used a wide variety of non-standard interfaces and communication protocols. During this time, Hewlett-Packard developed the HP-IB as an internal standard. For connectors and cables, HP-IB defined an electrical and mechanical interface. For transmitting individual bytes of data between instruments and computers, it defined handshaking, addressing, and general protocol.

IEEE 488.1

In 1975, the Institute of Electrical and Electronic Engineers (IEEE) approved IEEE 488-1975, which was based on Hewlett-Packard's internal HP-IB standard. They updated this standard which is IEEE 488.1-1987. Hewlett-Packard uses HP-IB to indicate that an instrument or controller conforms to the IEEE 488.1 standard.

Although it solved the problem of how to send bytes of data between instruments and computers, IEEE 488 did not specify the data bytes' meanings. Instrument manufacturers freely invented new commands as they developed new instruments. The format of data returned from instruments varied as well. By the early 1980s, work began on additional standards that specified how to interpret data sent via the 488 bus.

IEEE 488.2

In 1987, the IEEE approved IEEE 488.2-1987. This standard defined the interface capabilities of instruments and controllers in a measurement system connected by the 488 bus (HP-IB). In particular, IEEE 488.2 described how to send commands to instruments and how to send responses to controllers. Although it explicitly defined some frequently used commands, it still left the naming of most commands to instrument manufacturers. This made it possible for two similar instruments to conform to 488.2, yet have entirely different command sets.

SCPI

SCPI goes beyond 488.2 by defining a standard set of programming commands. For a given measurement function (such as frequency), SCPI defines the specific commands used to access that function via the 488 bus. If two analyzers both conform to the SCPI standard, for example, you would use the same command to set each analyzer's center frequency.

Standard commands provide two advantages:

- If you know how to control functions on one SCPI instrument, you know how to control the same functions on any SCPI instrument.
- Programs written for a particular SCPI instrument are easily adapted to work with a similar SCPI instrument.

SCPI builds on the 488 standards.

The standards can be thought of as layers, each defining a different aspect of communication between devices:

- The first layer, IEEE 488.1, defines the physical and electrical connection between devices. It also defines how a byte of data is transmitted and how devices are instructed to talk and listen.
- The next layer, IEEE 488.2, defines the syntax and data formats used to send data between devices. It also defines the structure of status registers.
- The third layer, also part of IEEE 488.2, defines the commands used for common tasks (such as resetting the device and reading the Status Byte).
- The last layer, SCPI, defines the commands used to control device-specific functions (such as setting frequency and amplitude). It also defines the parameters accepted by these functions and the values they return.

Caution

SCPI commands should not be used for programming multiple HP E1430A modules. If you are programming multiple HP E1430A modules, refer to C-programming or VXI register programming in this manual.

SCPI Commands

The E1430A is a register-based (not message-based) VXI module. The SCPI protocol is implemented using a SCPI driver that is downloaded into an HP E1405/06 Command Module. SCPI commands from a supported external controller can then be sent to the command module which interprets them and performs the appropriate register operations on the HP E1430A. You can also use SCPI commands in an embedded controller using Compiled SCPI. See chapter 1 for instructions on downloading the SCPI driver.

Command Syntax

This section describes the syntax elements used in the SCPI command reference. It also describes the general syntax rules for both kinds of command and query messages.

Note

For a more detailed discussion of message syntax, including example program listings, refer to the *Beginner's Guide to SCPI* available through your local Hewlett-Packard Sales Office.

Special Syntactic Elements

Several syntactic elements have special meanings:

- colon (:) — When a command or query contains a series of keywords, the keywords are separated by colons. A colon immediately following a keyword tells the command parser that the program message is proceeding to the next level of the command tree. A colon immediately following a semicolon tells the command parser that the program message is returning to the base of the command tree.
- semicolon (;) — When a program message contains more than one command or query, a semicolon is used to separate them from each other. For example, if you want to autorange inputs and then start a measurement using one program message, the message would be:

```
SENSE:VOLT:RANGE:AUTO ONCE,0.1,(@1,4);:INITIATE:IMMEDIATE
```

- comma (,) — A comma separates the data sent with a command or returned with a response. For example, the SENSE:VOLT:DC:RANGE:AUTO command requires two values to select the best range for the current input signal: one for the number of times to autorange (once) and one for the length of time in seconds. A message to autorange the inputs for 1.5 seconds would be:

```
SENSE:VOLT:DC:RANGE:AUTO ONCE,1.5
```

- <WSP> — One white space is required to separate a program message (the command or query) from its parameters. For example, the command “SENSE:VOLT:DC:RANGE:AUTO ONCE,1.5” contains a space between the program header (SENSE:VOLT:DC:RANGE:AUTO) and its program data (ONCE,1.5). White space characters are not allowed within a program header.

For more information, see the *Beginner's Guide to SCPI* available through your local Hewlett-Packard Sales Office.

Conventions

Syntax and return format descriptions use the following conventions:

- < > Angle brackets enclose the names of items that need further definition. The definition will be included in accompanying text. In addition, detailed descriptions of these elements appear at the end of this section.
- ::= “is defined as” When two items are separated by this symbol, the second item replaces the first in any statement that contains the first item. For example, A::=B indicates that B replace A in a statement that contains A.
- | “or” When items in a list are separated by this symbol, one and only one of the items can be chosen from the list. For example, A|B indicates that A or B can be chosen, but not both.
- ... An ellipsis (trailing dots) is used to indicate that the preceding element may be repeated one or more times.
- [] Square brackets indicate that the enclosed items are optional.
- { } Braces are used to group items into a single syntactic element. They are most often used to enclose lists and to enclose elements that are followed by an ellipsis.

Although command interpreter is not case sensitive, the case of letters in the command keyword is significant in the Command Reference. Keywords that are longer than four characters can have a short form or a long form. SCPI accepts either form. Upper-case letters show the short form of a command keyword. For more information, see the *Beginner's Guide to SCPI*.

SCPI is sensitive to white space characters. White space characters are not allowed within command keywords. They are only allowed when they are used to separate a command and a parameter.

A message terminator is required at the end of a program message or a response message. Use <NL>, <^END>, or <NL> <^END> as the *program message terminator*. The word <NL> is an ASCII new line (line feed) character. The word <^END> means that End or Identify (EOI) is asserted on the HP-IB interface at the same time the preceding data byte is sent. Most programming languages send these terminators automatically. For example, if you use the HP BASIC OUTPUT statement, <NL> is automatically sent after your last data byte. If you are using a PC, you can usually configure your system to send whatever terminator you specify.

For more information about terminating messages, see the *Beginner's Guide to SCPI*.

Syntax Descriptions

Syntax descriptions in the SCPI command reference chapter use the following elements:

<Channels> This item designates channel lists. Channel lists are used to specify the input channels on a single HP E1430A module, or the input channels of multiple HP E1430A card sets. The syntax for <Channels> is:

<Channels> ::= (@<Channel_Range>,<Module_Channel>)

<Channel_Range> ::= <First_Channel_Specifier>:<Second_Channel_Specifier>

Channel_Specifier ::= Integer

limits: dependent upon system configuration

both instances of <Channel_Specifier> must contain
the same number of dimensions

<Module_Channel> ::= <Module_Channel>(<Channel_Range>,
<Channel_Range>)

Example sense:voltage:dc:range:upper 0.5V (@1,3,4:6) sets the input range for channels 1, 3, 4, 5, and 6 to 0.5 volts.

In query-only commands, channel lists can specify only one channel. For example, to determine if channel 3 is activated to acquire data send "INP? (@3)".

<CHAR> This item designates a string of ASCII characters. There are no delimiters. Usually, the string is from an explicit set of responses. Maximum length is 12 characters.

<DEF_BLOCK> This item designates definite-length-block data which takes the following form:

<DEF_BLOCK> ::= #<byte><length_bytes><data_byte>[<data_byte>] . . .

<byte> ::= number of length bytes to follow (ASCII encoded)

<length_bytes> ::= number of data bytes to follow (ASCII encoded)

<data_byte> ::= unsigned 8-bit data

If the data is ASCII encoded (FORMat:DATA ASCii command):

<DEF_BLOCK> ::= floating-point-numeric[,floating-point-numeric] . . . <NL>

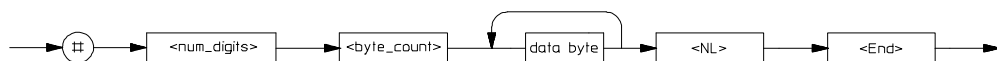

See the *Beginner's Guide to SCPI* for more information about block data.

<STRING> This item specifies any 8-bit characters delimited by single quotes or double quotes. The beginning and ending delimiter must be the same. If the delimiter character is in the string, it must be entered twice. (For example, to get "EXAMPLE", enter ""EXAMPLE"").

The Status Registers

Introduction

The HP E1430A's status registers contain information about various module conditions. The following sections describe the registers and tell you how to use them in your programs.

The General Status Register Model

The general status register model is the building block of the HP E1430A's status system. Most register sets in the module include all of the registers shown in the general model, although commands are not always available for reading or writing a particular register. The information flow within a register set starts at the condition register and ends at the register summary bit (see illustration). You control the flow by altering bits in the enable register.

Two register sets—Status Byte and Standard Event—are 8 bits wide. All others are 16 bits wide, but the most significant bit (bit 15) in the larger registers is always set to 0.

General Status Register Model

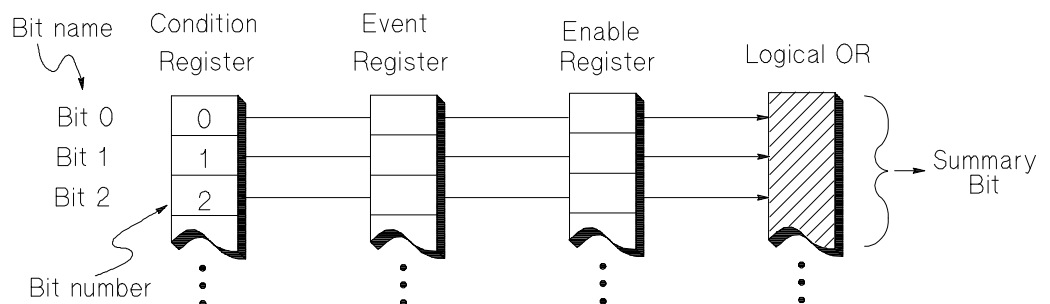

Condition Register

Condition registers continuously monitor hardware and firmware status. They represent the current state of the instrument. Bits in a condition register are not latched or buffered. They are updated in real time. When the condition monitored by a particular bit becomes true, the bit is set to 1. When the condition becomes false, the bit is reset to 0. Condition registers are read-only.

Event Register

Event registers latch condition changes. When a change occurs in the condition register, the corresponding event bit is set to 1. Once set, an event bit is no longer affected by condition changes. It remains set until the event register is cleared— either when you read the register or when you send the *CLS (clear status) command. Event registers are read-only.

An event register is cleared when you read it. All event registers are cleared when you send the *CLS command.

Enable Register

Enable registers control the reporting of events (latched conditions) to the register summary bit. If an enable bit is set to one, the corresponding event bit is included in the logical ORing process that determines the state of the summary bit. (The summary bit is only set to 1 if one or more enabled event bits are set to 1.) You can read and write all enable registers.

Flow of Information Within a Register Set

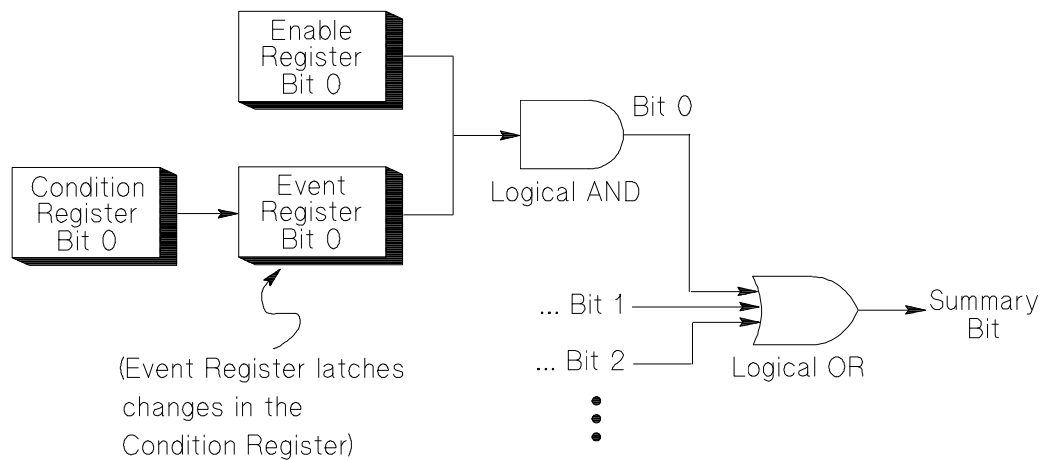

How to Use Registers

There are two methods you can use to access the information in status registers:

- The direct-read method.
- The service request (SRQ) method.

In the direct-read method, the module has a passive role. It only tells the controller that conditions have changed when the controller asks the right question. In the SRQ method, the module takes a more active role. It tells the controller when there has been a condition change without the controller asking. Either method allows you to monitor one or more conditions.

When you monitor a condition with the direct-read method, you must:

- 1** Determine which register contains the bit that monitors the condition.
- 2** Send the unique HP-IB query that reads that register.
- 3** Examine the bit to see if the condition has changed.

The direct-read method works well if you do not need to know about changes the moment they occur. It does not work well if you must know when a condition changes immediately. To detect a change in a condition your program would need to continuously read the registers at very short intervals. This makes the program relatively inefficient. It is better to use the SRQ method.

The Service Request Process

When you monitor a condition with the SRQ method request, you must:

- 1 Determine which bit monitors the condition.
- 2 Determine how that bit reports to the request service (RQS) bit of the Status Byte.
- 3 Send HP-IB commands to enable the bit that monitors the condition and to enable the summary bits that report the condition to the RQS bit.
- 4 Enable the controller to respond to service requests.

When the condition changes, the module sets its RQS bit and the HP-IB's SRQ line. The controller is informed of the change as soon as it occurs. The time the controller would otherwise have used to monitor the condition can now be used to perform other tasks. Your program determines how the controller responds to the SRQ.

Generating a Service Request

To use the SRQ method, you must understand how service requests are generated. As shown in the illustration below, other register sets in the HP E1430A report to the Status Byte. Most of them report directly, but two report indirectly—via the Questionable Status register set.

Generating a Service Request

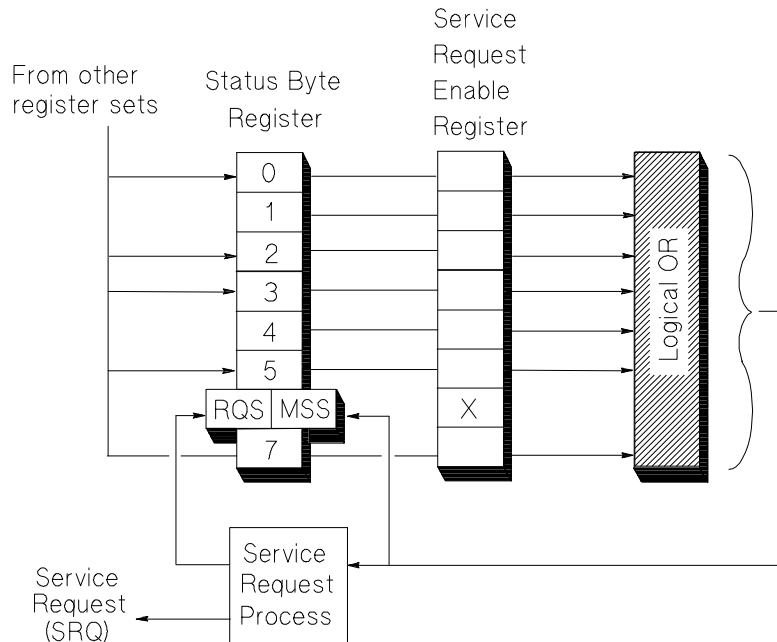

When a register set causes its summary bit in the Status Byte register to change from 0 to 1, the module can initiate the service request (SRQ) process. However, the process is only initiated if both of the following conditions are true:

- The corresponding bit of the Service Request enable register;initiating SRQ is also set to 1.
- The module does not have a service request pending. (A service request is considered to be pending between the time the module's SRQ process is initiated and the time the controller reads the Status Byte register with a serial poll.)

The SRQ process sets the HP-IB's SRQ line true. It also sets the Status Byte's request service (RQS) bit to 1. Both actions are necessary to inform the controller that the HP E1430A requires service. Setting the SRQ line only informs the controller that some device on the bus requires service. Setting the RQS bit allows the controller to determine that the HP E1430A, in particular, requires service.

If your program enables the controller to detect and respond to service requests, it should instruct the controller to perform a serial poll when the HP-IB's SRQ line is set true. Each device on the bus returns the contents of its Status Byte register in response to this poll. The device whose RQS bit is set to 1 is the device that requested service.

When you read the module's Status Byte with a serial poll, the RQS bit is reset to 0. Other bits in the register are not affected.

As implied in the previous illustration, bit 6 of the Status Byte register serves two functions; the request service function (RQS) and the master summary status function (MSS). Two different methods for reading the register allow you to access the two functions. Reading the register with a serial poll allows you to access the bit's RQS function. Reading the register with *STB allows you to access the bit's MSS function.

The HP E1430A Register Sets

Register Summary

The HP E1430A uses four register sets to keep track of instrument status:

- Status Byte.
- Questionable Status.
- Standard Event.
- Operational Status.

Their reporting structure is summarized in the illustration below. They are described in greater detail in the following sections.

Register bits not explicitly presented in the following sections are not used by the HP E1430A. A query to one of these bits returns a value of 0.

HP E1430A Register Sets

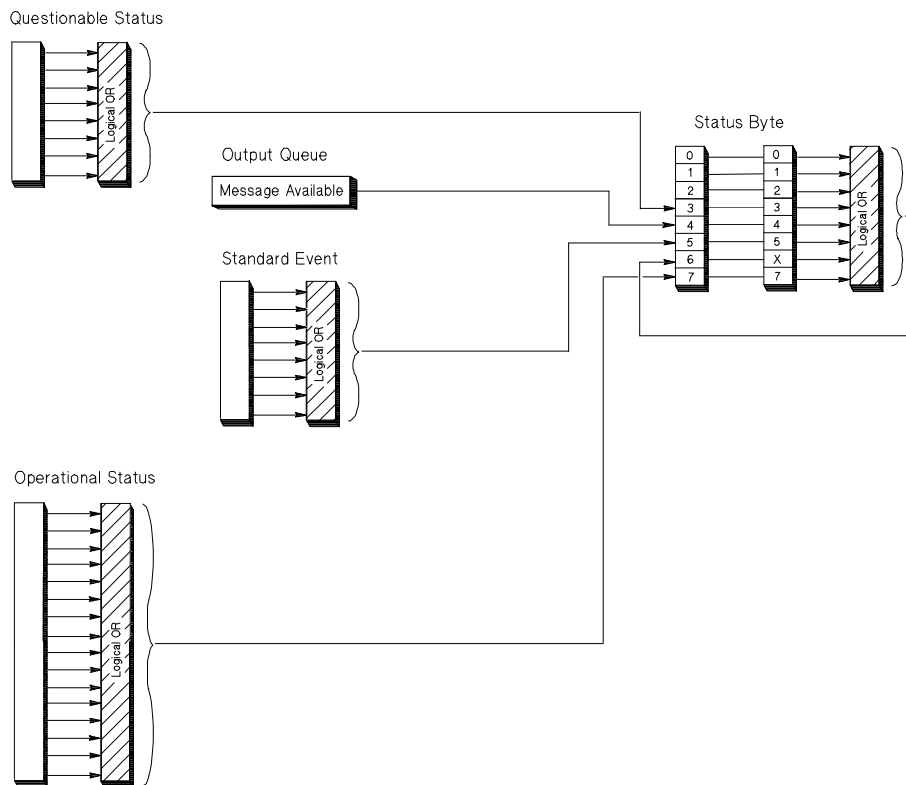

Status Byte Register Set

The Status Byte register set summarizes the states of the other register sets and monitors the HP E1430A output queue. It is also responsible for generating service requests (see "Generating a Service Request" earlier in this chapter).

The Status Byte Register Set

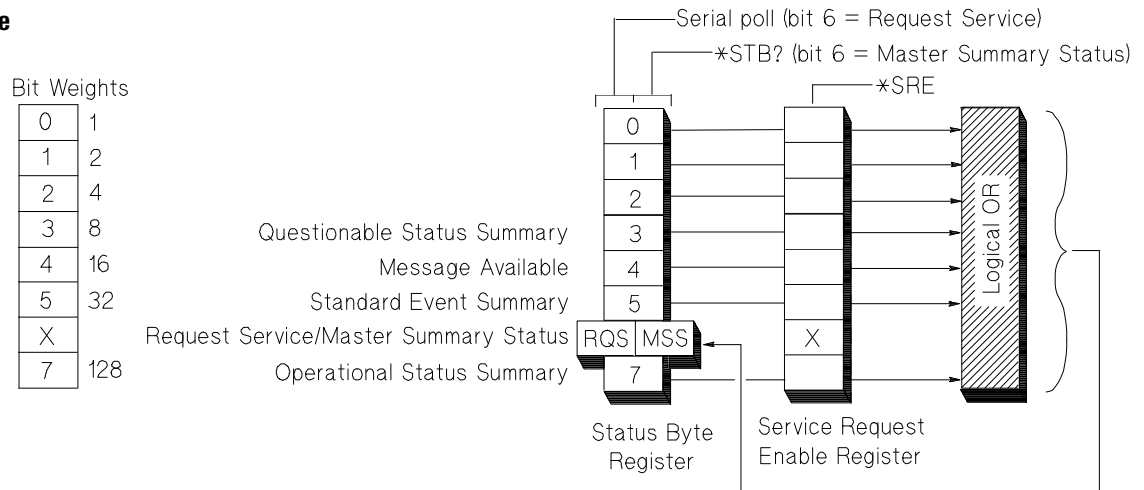

The Status Byte register set does not conform to the general status register model described at the beginning of this chapter. It contains only two registers: the Status Byte register and the Service Request enable register. The Status Byte register behaves like a condition register for all bits except bit 6. The Service Request enable register behaves like a standard enable register except that bit 6 is always set to 0.

Bits in the Status Byte register are set to 1 under the following conditions:

- Questionable Status Summary (bit 3) is set to 1 when one or more enabled bits in the Questionable Status event register are set to 1.
- Message Available (bit 4) is set to 1 when the output queue contains a response message.
- Standard Event Summary (bit 5) is set to 1 when one or more enabled bits in the Standard Event event register are set to 1.
- Master Summary Status (bit 6, when read by *STB) is set to 1 when one or more enabled bits in the Status Byte register are set to 1.
- Request Service (bit 6, when read by serial poll) is set to 1 by the service request process (see "Generating a Service Request" earlier in this chapter).
- Operational Status Summary (bit 7) is set to 1 when one or more enabled bits in the Operational Status event register are set to 1.

The illustration also shows the commands you use to read and write the Status Byte registers.

Questionable Status Register Set

The Questionable Status register set monitors conditions that affect the quality of measurement data. status register.

The Questionable Status Register Set

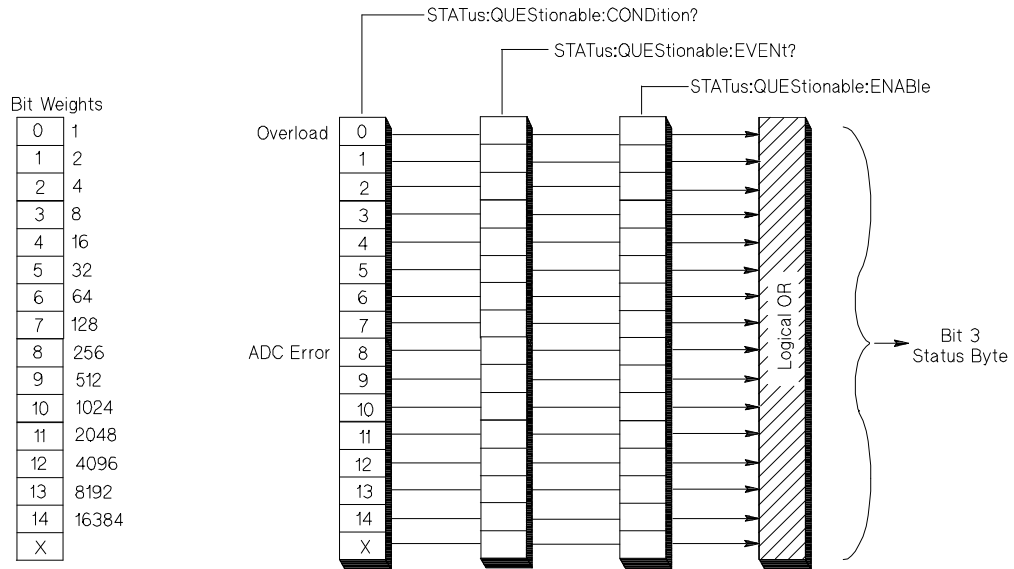

Bits in the Questionable Status condition register are set to 1 under the following conditions.

- Overload (bit 0) is set to 1 when the input to the ADC exceeds its range.
- ADC error (bit 8) is set to 1 when there is a hardware error in the Analog-to-Digital Converter.

The illustration also shows the commands you use to read and write the Questionable Status registers.

Standard Event Register Set; standard event

The Standard Event register set monitors HP-IB errors and synchronization conditions.

The Standard Event Register Set

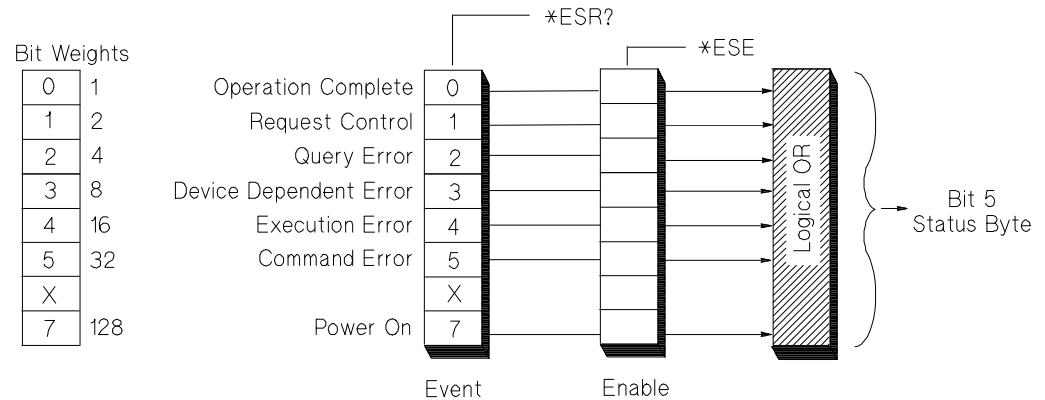

The Standard Event register set does not conform to the general status register model described at the beginning of this chapter. It contains only two registers: the Standard Event event register and the Standard Event enable register.

Bits in the Standard Event event register are set to 1 under the following conditions:

- Operation Complete (bit 0) is set to one when you send the *OPC command to the module.
- Query Error (bit 2) is set to 1 when the command parser detects a query error.
- Device Dependent Error (bit 3) is set to 1 when the command parser detects a device-dependent error.
- Execution Error (bit 4) is set to 1 when the command parser detects an execution error.
- Command Error (bit 5) is set to 1 when the command parser detects a command error.
- Power On (bit 7) is set to 1 when you turn on the module.

The illustration also shows the commands you use to read and write the Standard Event registers.

Operational Status Register Set

The Operational Status register set monitors conditions in the HP E1430A measurement process.

The Operational Status Register Set

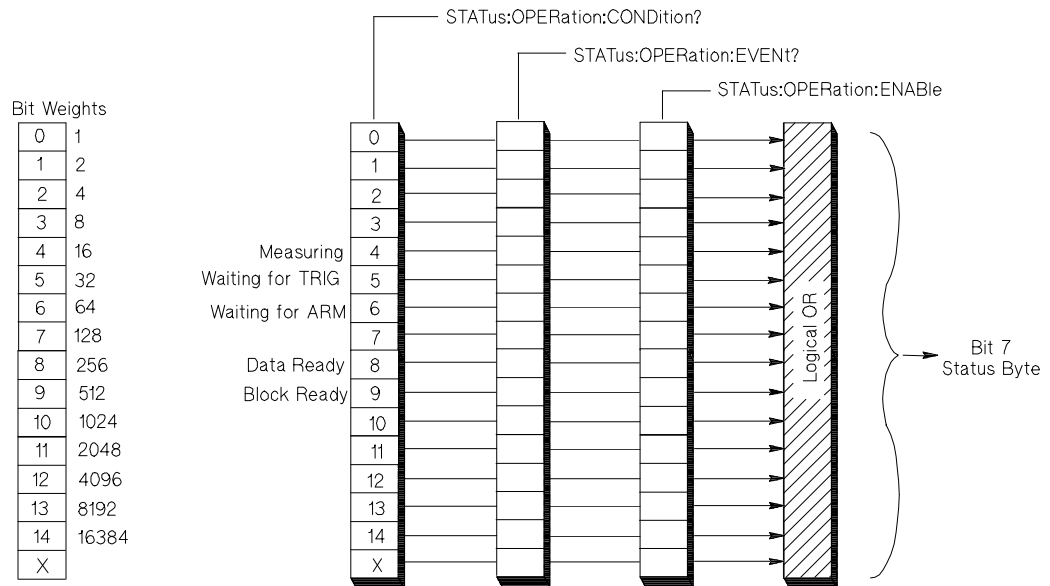

Bits in the Operational Status condition register are set to 1 under the following conditions:

- Measuring (bit 4) is set to 1 while the HP E1430A is collecting data for a measurement.
- Waiting for TRIG (bit 5) is set to 1 when the HP E1430A is ready to accept a trigger signal from one of the trigger sources. (If a trigger signal is sent before this bit is set, the signal is ignored.)
- Waiting for ARM (bit 6) is set to 1 when the HP E1430A is in the idle state.
- Data Ready (bit 8) is set when data is available on the VME data port.
- Block Ready (bit 9) is set when a complete block of data is ready.

The illustration also shows the commands you use to read and write the Operational Status registers.

Register Set Summary

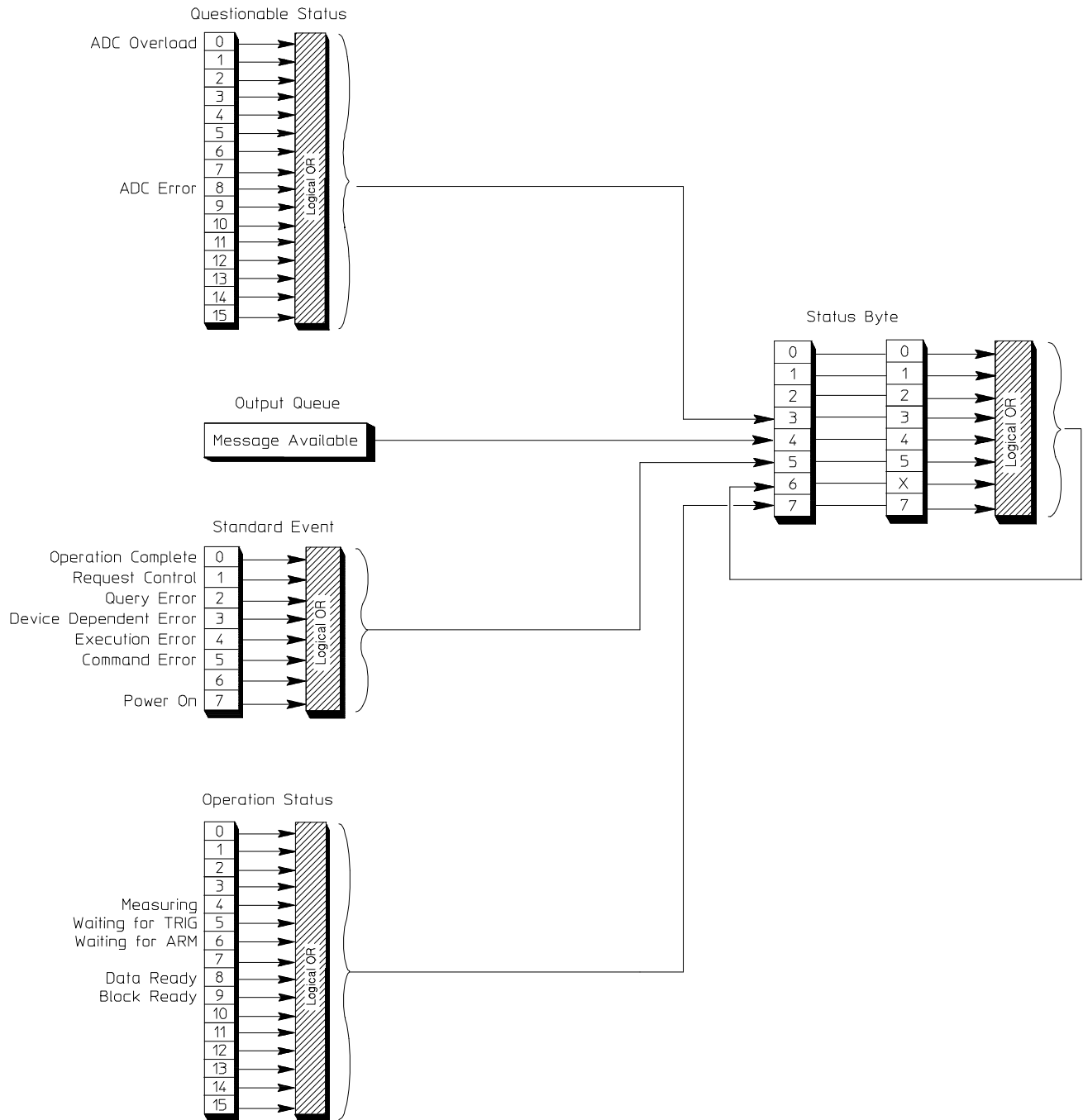

SCPI Common Commands

The following section describes all of the IEEE 488.2 common commands implemented by the HP E1430A. An important property of all common commands is that you can send them without regard to a program message's position in the HP-IB command tree.

***CLS**

command

Clears the Status Byte by emptying the error queue and clearing all event registers.

Command syntax: *CLS

Example Statements: OUTPUT 70901; "*Cls"
OUTPUT 70901; "*CLS"

Attribute Summary: Option: not applicable

Preset State: not applicable

SCPI Compliance: confirmed

Description: This command clears the Status Byte register. It does so by emptying the error queue and clearing (setting to 0) all bits in the event registers of the following register sets:

- Questionable Status.
- Standard Event.
- Operation Status.

*CLS does not change the current state of enable registers.

To guarantee that the Status Byte's Message Available and Master Summary Status bits are cleared, send *CLS immediately following a Program Message Terminator.

See the "VXI Registers" chapter for more information on the Status Byte register.

***ESE**

command/query

Sets bits in the Standard Event enable register.

Command syntax: *ESE <number>|<bound>

<number> ::= a real number (NRf data) limits: 0:255

<bound> ::= MAX|MIN

Example Statements: OUTPUT 70901;"*ese 101"
OUTPUT 70901;"*Ese 214"

Query syntax: *ESE?

Return Format: NR1

Attribute Summary: Option: not applicable

Preset State: dependent on setting of *PSC

SCPI Compliance: confirmed

Description: This command allows you to set bits in the Standard Event enable register. Assign a decimal weight to each bit you want set (to 1) according to the following formula:

$$2^{(\text{bit_number})}$$

with acceptable values for bit_number being 0 through 7. Add the weights and then send the sum with this command.

When an enable register bit is set to 1, the corresponding bit of the Standard Event event register is enabled. All enabled bits are logically ORed to create the Standard Event summary, which reports to bit 5 of the Status Byte. Bit 5 is only set to 1 if both of the following are true:

- One or more bits in the Standard Event event register are set to 1.
- At least one set bit is enabled by a corresponding bit in the Standard Event enable register.

The query returns the current state of the Standard Event enable register. The state is returned as a sum of the decimal weights of all set bits.

For more information on the Standard Event register set, see the "VXI Registers" chapter.

***ESR?**

query

Reads and clears the Standard Event event register.

Query syntax: *ESR?

Example Statements: OUTPUT 70901,"*ESR?"
OUTPUT 70901,"*esr?"

Return Format: NR1

Attribute Summary: Option: not applicable

Preset State: +0

SCPI Compliance: confirmed

Description: This query returns the current state of the Standard Event event register. The state is returned as a sum of the decimal weights of all set bits. The decimal weight for each bit is assigned according to the following formula:

$$2^{(\text{bit_number})}$$

with acceptable values for bit_number being 0 through 7.

The query clears the register after it reads the register.

A bit in this register is set to 1 when the condition it monitors becomes true. A set bit remains set, regardless of further changes in the condition it monitors, until one of the following occurs:

- You read the register with this query.
- You clear all event registers with the *CLS command.

For more information on the Standard Event register set, see the "VXI Registers" chapter.

***IDN?**

query

Returns a string that identifies the HP E1430A.

Query syntax: *IDN?

Example Statements: OUTPUT 70901; "*Idn?"
OUTPUT 70901; "*IDN?"

Return Format: HEWLETT-PACKARD,E1430A,<software_version>

Attribute Summary: Option: not applicable
Preset State: instrument dependent
SCPI Compliance: confirmed

Description: The response to this query identifies your HP E1430A.

The query returns:

- The name of the manufacturer, Hewlett-Packard.
- The product number.
- The version of the software.

***OPC**

command/query

Sets or queries completion of all pending overlapped commands.

Command syntax: *OPC

Example Statements: OUTPUT 70901;"*opc"
OUTPUT 70901;"*Opc"

Query syntax: *OPC?

Return Format: NR1

Attribute Summary: Option: not applicable

Preset State: 0

SCPI Compliance: confirmed

Description: There are no overlapped commands in the HP E1430A. This command/query is included for IEEE 488.2 compliance.

***OPT?**

query

Returns a string that identifies the module's option configuration.

Query syntax: *OPT?

Example Statements: OUTPUT 70901; "*OPT?"
OUTPUT 70901; "*opt?"

Return Format: "AYD"

Attribute Summary: Option: not applicable

Preset State: 0

SCPI Compliance: confirmed

Description: The response to this query identifies the module's option configuration. Options are identified by the following:

- AYD 10.24 MHz clock

The query returns a null string ("") if no special options are installed in the module (that is, the module has a 10.0 MHz clock).

***RST**

command

Executes a device reset.

Command syntax: *RST

Example Statements: OUTPUT 70901; "*RST"
OUTPUT 70901; "*rst"

Attribute Summary: Option: not applicable

Preset State: not applicable

SCPI Compliance: confirmed

Description: This command returns the module to a reset state.

A waiting period of 20 seconds is required after reset to allow the ADC calibration to settle to specified accuracy.

***SRE**

command/query

Sets bits in the Service Request enable register.

Command syntax: *SRE <number>|<bound>

<number> ::= a real number (NRf data)
limits: 0:255

<bound> ::= MAX|MIN

Example Statements: OUTPUT 70901,"*Sre 40"
OUTPUT 70901,"*SRE 97"

Query syntax: *SRE?

Return Format: NR1

Attribute Summary: Option: not applicable
Preset State: dependent on setting of *PSC
SCPI Compliance: confirmed

Description: This command allows you to set bits in the Service Request enable register. Assign a decimal weight to each bit you want set (to 1) according to the following formula:
$$2^{(\text{bit_number})}$$

with acceptable values for bit_number being 0 through 7. Add the weights and then send the sum with this command.

The module ignores the setting you specify for bit 6 of the Service Request enable register. This is because the corresponding bit of the Status Byte register is always enabled.

The module requests service from the active controller when one of the following occurs:

- A bit in the Status Byte register changes from 0 to 1 while the corresponding bit of the Service Request enable register is set to 1.
- A bit in the Service Request enable register changes from 0 to 1 while the corresponding bit of the Status Byte register is set to 1.

The query returns the current state of the Service Request enable register. The state is returned as a sum of the decimal weights of all set bits.

***STB?**

query

Reads the Status Byte register.

Query syntax: *STB?

Example Statements: OUTPUT 70901,"*stb?"
OUTPUT 70901,"*Stb?"

Return Format: NR1

Attribute Summary: Option: not applicable

Preset State: variable

SCPI Compliance: confirmed

Description: This command allows you to set bits in the Status Byte register. The state is returned as a sum of the decimal weights of all set bits. The decimal weight for each bit is assigned according to the following formula:

$$2^{(\text{bit_number})}$$

with acceptable values for bit_number being 0 through 7.

The register is not cleared by this query. To clear the Status Byte register, you must send the *CLS command.

Bits in the Status Byte register are defined as follows:

- Bit 0 summarizes all enabled bits of the User Status register.
- Bit 1 is reserved.
- Bit 2 summarizes all enabled bits of the Device State register.
- Bit 3 summarizes all enabled bits of the Questionable Status register.
- Bit 4 is the Message Available (MAV) bit. It is set whenever there is something in the module's output queue.
- Bit 5 summarizes all enabled bits of the Standard Event Status register.
- Bit 6, when read with this query (*STB?), acts as the Master Summary Status (MSS) bit. It summarizes all enabled bits of the Status Byte register. Bit 6 acts as the Request Service (RQS) bit when it is read by a serial poll.
- Bit 7 summarizes all enabled bits of the Operation Status register.

***TRG**

command

Triggers the module if TRIG:SOUR is BUS.

Command syntax: *TRG

Example Statements: OUTPUT 70901,"*TRG"
OUTPUT 70901,"*trg"

Attribute Summary: Option: not applicable

Preset State: not applicable

SCPI Compliance: confirmed

Description: This command triggers the HP E1430A module if the following two conditions are met:

- The HP-IB is designated as the trigger source. (Send the TRIG:SOUR:BUS command.)
- The module is waiting to trigger. (Bit 5 of the Operational Status condition register must be set.) It is ignored at all other times.

The *TRG command has the same effect as TRIG:IMM. It also has the same effect as the HP-IB bus management command Group Execute Trigger (GET).

This command triggers the module when the following two conditions are met:

- The HP-IB (BUS) is designated as the trigger source. (See the TRIGGER:SOURce command in this chapter.)
- The module is waiting to trigger. (Bit 5 of the Operational Status register must be set.)

The *TRG command has the same effect as TRIG:IMM. It also has the same effect as the HP-IB bus management command Group Execute Trigger (GET).

***TST?**

query

Tests the module hardware and returns the results.

Query syntax: *TST?

Example Statements: OUTPUT 70901,"*Tst?"
OUTPUT 70901,"*TST?"

Return Format: NR1

Attribute Summary: Option: not applicable

Preset State: not applicable

SCPI Compliance: confirmed

Description: The module's self-test performs the HP E1430A diagnostic tests. If the results are within specified limits, the module returns 0. If the results exceed the specified limits, the module returns 1 and an error message is put in the error queue. The length of the self test is approximately 3 minutes.

***WAI**

command

Holds off processing of subsequent commands until all preceding commands have been processed.

Command syntax: *WAI

Example Statements: OUTPUT 70901; "*wai"
OUTPUT 70901; "*Wai"

Attribute Summary: Option: not applicable

Preset State: not applicable

SCPI Compliance: confirmed

Description: There are no overlapped commands in the HP E1430A so this command has no effect. It is included to comply with IEEE 488.2.

Other SCPI Commands

This section describes all commands implemented by the HP E1430A that are not IEEE 488.2 common commands.

ABORt

command

Abort data collection.

Command syntax: ABORt

Example Statements: OUTPUT 70901;"abort"
OUTPUT 70901;"ABOR"

Attribute Summary: Option: not applicable

Preset State: not applicable

SCPI compliance: confirmed

Description: This command stops any current data collection and returns the HP E1430A to the IDLE state.

DATA[:DATA]

query

Read data from HP E1430A.

- Query syntax:** DATA[:DATA]?
- Example Statements:** OUTPUT 70901;"data:data?"
OUTPUT 70901;"DATA?"
- Return Format:** Depends on data format
- Attribute Summary:** Option: not applicable
Preset State: not applicable
SCPI compliance: confirmed

Description: This command reads data from an HP E1430A. Data can be read in either raw or scaled format. Raw data is the unscaled fixed point data from the analog to digital converter. Scaled data is IEEE 32-bit floating-point data that has been scaled into volts. See the DATA:SCALE command to set the data format.

The size of each raw data point depends on the setting of the data size (by the DATA:SIZE command) and of the data type (by the DATA:TYPE command). The size of the raw data returned and the scaling factor needed to scale it into volts are shown in the table below:

Data sizes and the scaling factors for raw data

Data size	Data type	Bytes per sample	Scale factor for value in volts
16	real	2	$\text{RANGE}/(K \times 2^{16})$
16	complex	4	$\text{RANGE}/(K \times 2^{16})$
32	real	4	$\text{RANGE}/(K \times 2^{32})$
32	complex	8	$\text{RANGE}/(K \times 2^{32})$

RANGE is determined by the INPUT:RANGE? query, and $K = 0.216715$. This table applies only to single-pass data without status appended. See documentation on the DATA:TAG and DATA:TRAILER commands for data format in the cases of multi-pass data and data with status appended.

The response depends upon the setting of the output data format (see FORMAT command). If ASCII is selected, data is output as a comma-separated list of numbers. If PACKED is selected, data is output as an arbitrary block according to IEEE 488.2. The block consists of a “#” character, one non-zero digit indicating the number of length digits to follow, the length digits indicating the number of data bytes, the data bytes, and a line-feed character.

DATA:SCALE

command/query

Set data output to raw or scaled data.

Command syntax: DATA:SCALE RAW|SCALed|REAL

Example Statements: OUTPUT 70901;"data:scale raw"
OUTPUT 70901;"DATA:SCAL SCAL"

Query syntax: DATA:SCALE?

Return Format: CHAR

Attribute Summary: Option: not applicable

Preset State: RAW

SCPI compliance: instrument specific

Description: This command determines the scaling of the data from an HP E1430A. When the RAW mode is selected data returned by the DATA? query is the raw data from the ADC. This data is in signed twos-compliment integer format and represents a fraction of the current range setting. (See the table under the DATA[:DATA] query for the appropriate scaling factor.)

When SCALed is selected, the data is output in IEEE 32-bit floating point format and is scaled to be in volts. When REAL is selected, the data is output in IEEE 64-bit floating point format and is scaled to be in volts. See diagrams below and ANSI/IEEE Std 754-1985 for details on floating point number standards.

Fields in binary floating point numbers

Field	32-bit Width (bits)	64-bit Width (bits)
Sign (s)	1	1
Exponent (e)	8	11
Fraction (f)	23	52

32-bit format

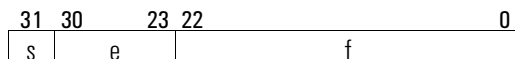

64-bit format

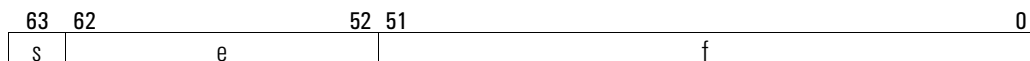

DATA:SIZE

command/query

Select 16 or 32 bit data size.

Command syntax: DATA:SIZE 16|32

Example Statements: OUTPUT 70901;"data:size 16"
OUTPUT 70901;"DATA:SIZE 32"

Query syntax: DATA:SIZE?

Return Format: NR1

Attribute Summary: Option: not applicable

Preset State: 32

SCPI compliance: instrument specific

Description: The output data size of raw data from the ADC can be set to either 16 or 32 bits. For greatest accuracy use the 32-bit mode. If size of stored data is more important, use the 16-bit mode.

DATA:TAG

command/query

Determine the placement of the pass tag for multi-pass data.

Command syntax: DATA:TAG 24|32

Example Statements: OUTPUT 70901;"DATA:tag 24"
OUTPUT 70901;"DATA:TAG 32"

Query syntax: DATA:TAG?

Return Format: NR1

Attribute Summary: Option: not applicable

Preset State: 32

SCPI compliance: instrument specific

Description: When the output of the decimation filter is selected by the [SENSe:]FILTer:MODE command to be ALL, each stage of the decimation filter whose bandwidth is less than or equal to the current span are time multiplexed on the output. A pass tag is superimposed on this data to indicate which filter pass the data is from. In general, the tag replaces five of the original data bits for each data sample. Thus the tag must be positioned to have a minimum effect on the data accuracy. In the 16-bit real mode, the tag does not replace any data bits, but is inserted as an extra 16-bit word.

Normally the tag is placed over the least significant bits, however, some controllers which read the data may only implement 24-data precision and will not be able to read the tag. In this case, the DATA:TAG command is set to 24 to position the tag correctly for these controllers. See the table below for tag position versus data size and type.

Multi-pass output data formats

Type	Precision	Tag	Format r = real data, i = imaginary data, t = tag
Real	16	24 or 32	rrrrrrrr rrrrrrrr 00000000 000ttttt
Real	32	32	rrrrrrrr rrrrrrrr rrrrrrrr rrrttttt
Real	32	24	rrrrrrrr rrrrrrrr rrrttttt rrrrrrrr
Complex	16	24 or 32	rrrrrrrr rrrrrrrr iiiiinnn iitttttt
Complex	32	32	rrrrrrrr rrrrrrrr rrrrrrrr rrrrrrrr iiiiinnn iiiiinnn iitttttt
Complex	32	24	rrrrrrrr rrrrrrrr rrrrrrrr rrrrrrrr iiiiinnn iiiiinnn iitttttt iiiiinnn

DATA:TRAIler

command/query

Enable/disable status information appended to data block.

Command syntax: DATA:TRAIler ON|OFF

Example Statements: OUTPUT 70901;"DATA:trailer off"
OUTPUT 70901;"DATA:TRA ON"

Query syntax: DATA:TRAIler?

Return Format: CHAR

Attribute Summary: Option: not applicable

Preset State: OFF

SCPI compliance: instrument specific

Description: A byte of status information can be appended to a block of data collected in the HP E1430A. Bit 0 of this status byte is set if there was an ADC overload in the block, and bit 1 is set if there was an ADC error during acquisition of the block of data. If the VME bus is used to transfer the data, then the status byte is located in the lower byte of the 16-bit data. When the data is output via the local bus, the status byte is marked as the last byte of a transfer block.

DATA:TYPE

command/query

Select real or complex data output.

Command syntax: DATA:TYPE REAL|COMPLex

Example Statements: OUTPUT 70901;"DATA:type real"
OUTPUT 70901;"DATA:TYPE COMP"

Query syntax: DATA:TYPE?

Return Format: CHAR

Attribute Summary: Option: not applicable

Preset State: REAL

SCPI compliance: instrument specific

Description: The output data type can be set to either real or complex data. If complex data is selected, each sample point is output with the real part first followed by the imaginary part.

The module produces complex time data by digitally mixing ADC data with the digital local oscillator. You can set the frequency of the digital local oscillator using the [SENSE:]FREQUENCY:CENTer command.

DATA:WRAP

command/query

Set data re-read mode for the FIFO.

Command syntax: DATA:WRAP ON|OFF

Example Statements: OUTPUT 70901;"DATA:wrap on"
OUTPUT 70901;"DATA:WRAP OFF"

Query syntax: DATA:WRAP?

Return Format: BOOLEAN

Attribute Summary: Option: not applicable

Preset State: OFF

SCPI compliance: instrument specific

Description: This command allows repeated post-processing of full data blocks. Setting the re-read (wrap) mode to ON limits the FIFO to one block of data. Data reads that try to read beyond the end of the block wrap around to the beginning of the block. This allows the host to re-read the same data as many times as desired.

DIAGnostic:REGister

command/query

Read or write individual registers on an HP E1430A.

Command syntax: DIAGnostic:REGister<register number>,<value>

where <register number> ::= decimal address offset of register
<value> ::= 16-bit value to write to the register

Example Statements: OUTPUT 70901,"diagnostic:register 62, 0"
OUTPUT 70901,"DIAG:REG 4, 7"

Query syntax: DIAGnostic:REGister?<register number>

Return Format: NR1

Attribute Summary: Option: not applicable

Preset State: not applicable

SCPI compliance: instrument specific

Description: This command allows you to do low level reads and writes on the registers on an HP E1430A. Many registers on the HP E1430A are write-only and cannot be read directly with the normal VXI:REGister:READ? command. To write to an HP E1430A register use the DIAGnostic:REGister command so that the proper internal state of the registers is maintained. Use DIAGnostic:REGister commands instead of the VXI:REGister:READ? and VXI:REGister:WRITE commands.

To obtain the address offset of the register, see *VXI Registers*, page 12-2. Remember to use the decimal address values for the register.

FORMat

command/query

Set the output data to binary or ASCII.

Command syntax: FORMat ASCiiPACKed

Example Statements: OUTPUT 70901;"format ascii"
OUTPUT 70901;"FORM PACK"

Query syntax: FORMat?

Return Format: CHAR

Attribute Summary: Option: not applicable

Preset State: PACK

SCPI compliance: confirmed

Description: This command determines the output format for data. If ASCii is selected, data is output as a comma-separated list of numbers. If PACKed is selected, the data is output in binary format. See the DATA? query for details on data format.

INITialize[:IMMediate]

command

Initialize (arm) an HP E1430A for data collection.

Command syntax: INIT:IMMediate

Example Statements: OUTPUT 70901;"initialize:immediate"
OUTPUT 70901;"INIT"

Attribute Summary: Option: not applicable

Preset State: not applicable

SCPI compliance: confirmed

Description: This command initializes the HP E1430A by moving it from the IDLE state to the ARM state. The HP E1430A then stays in the ARM state until a trigger event occurs, at which time it moves to the TRIGGER state.

This command was designed for only one ADC. It pulls the SYNC line too many times and doesn't make sure both Master and Slave modules are in the same measurement state. Because of this, it is required to perform direct register writes on the measurement state register (DEC-10 HEX-0A).

The following example shows how to accomplish this:

- Step 1. Force the Slave ADC2 into the IDLE state, then transition to normal operation and wait for a SYNC pulse.
For ADC2: Write text *"diag:reg 10,3" EOL*
- Step 2. Set Master ADC1 into the IDLE state, transition to normal operation, then pull the SYNC line.
For ADC1: Write text *"diag:reg 10,7" EOL*
- Step 3. Pull the SYNC line on the Master ADC1 which in turn pulls the SYNC line on the Slave ADC2 and moves both modules into the trigger state.
For ADC1: Write text *"diag:reg 10,2" EOL*

INPut:COUPling

command/query

Selects ac or dc coupling to input.

Command syntax: INPut:COUPling (AC|DC|GROund)

Example Statements: OUTPUT 70901;"input:coup ac"
OUTPUT 70901;"INP:COUP DC"

Query syntax: INPut:COUPling?

Return Format: CHAR

Attribute Summary: Option: not applicable

Preset State: DC

SCPI compliance: confirmed

Description: When dc is selected, the input connector is directly coupled to the ADC. When ac is selected, the input is coupled through a 0.2 μ F capacitor. When GROund is selected, the input of the ADC is connected to ground.

INPut:FILTer[:LPASs][:STATe]

command/query

Selects the state of the input anti-alias filter.

Command syntax: INPut:FILTer[:LPASs][:STATe] (ON|OFF)

Example Statements: OUTPUT 70901;"input:filter on"
OUTPUT 70901;"INP:FILT:LPAS ON"

Query syntax: INPut:FILTer[:LPASs][:STATe]?

Return Format: CHAR

Attribute Summary: Option: not applicable

Preset State: ON

SCPI compliance: confirmed

Description: This command controls that state of the analog anti-alias filter in the input section. This filter should always be ON to prevent aliased data. Use caution when turning this filter OFF to collect unprotected data.

INPut:LOW

command/query

Set the input connector's shield to either float or ground.

Command syntax: INPut:LOW (FLOat|GROund)

Example Statements: OUTPUT 70901;"input:low float"
OUTPUT 70901;"INP:LOW GRO"

Query syntax: INPut:LOW?

Return Format: CHAR

Attribute Summary: Option: not applicable

Preset State: FLO

SCPI compliance: confirmed

Description: Selecting GROund grounds the analog input connector's shell to chassis ground.

Selecting FLOat isolates the input connector's shell from chassis ground by a 50 ohm resistor in parallel with a 0.04 μ F capacitor. This provides sufficient impedance to suppress low frequency ground loop pickup.

INPut:OFFSet

command/query

Input dc offset correction.

Command syntax: INPut:OFFSet <number>

where <number> = a real number (NRf data) -1.0 - 1.0

Example Statements: OUTPUT 70901,"input:offset .3"
OUTPUT 70901,"INP:OFFS -.1"

Query syntax: INPut:OFFSet?

Return Format: NR3

Attribute Summary: Option: not applicable

Preset State: 0.0

SCPI compliance: confirmed

Description: The offset voltage is applied to the ADC after the input attenuators. Its main purpose is to compensate for the dc offset of the input amplifiers. The value is specified as a fraction of the ADC's full scale.

Zeroing a dc offset can be done automatically with the [SENSE:]CORRection:INPut:OFFSet command.

[SENSe:]CORRection:INPut:OFFSet

command

Perform auto-zero of input DC offset.

Command syntax: [SENSe:]CORRection:INPut:OFFSet

Example Statements: OUTPUT 70901;"sense:correction:input:offset"
OUTPUT 70901;"CORR:INP:OFFS"

Attribute Summary: Option: not applicable

Preset State: not applicable

SCPI compliance: instrument specific

Description:

This command saves the current state of the HP E1430A, grounds the input of the ADC, and calculates the dc offset voltage needed to zero the ADC. It calculates this auto-zero value for each range setting. It then restores the previous state of the module.

For any future range changes the module then applies the appropriate offset voltage to the ADC. This cancels any internal offset in the analog front end.

This command overwrites any offset that has been set with the INPut:OFFSet command.

[SENSe:]CORRection:TRIGger:PHASe?

query

Return the delay between the trigger event and the first sample in the FIFO.

Query syntax: [SENSe:]CORRection:TRIGger:PHASe?

Example Statements: OUTPUT 70901;"sense:correction:trigger:phase?"
OUTPUT 70901;"CORR:TRIG:PHAS?"

Return Format: NR3

Attribute Summary: Option: not applicable
Preset State: not applicable
SCPI compliance: instrument specific

Description: This query returns a correction factor between the trigger event and the first sample in the FIFO with an accuracy of one sample clock period. The value returned represents the number of output sample periods between the trigger event and the time of the first sample in a block of data in the FIFO.

The resolution of the trigger delay programmed with the [SENSe:]SWEep:OFFSet:POINts command is limited to the period of the samples from the output of the decimation filter, not the ADC clock period prior to decimation. For a small span, this granularity of the trigger delay is many sample clock periods, since it must always be an integral number of output sample periods. See the FREQuency:SPAN command for the formula for the output sample rate. You can improve the trigger timing resolution using this query, since its result has the resolution of one ADC sample clock period.

In a synchronous group of multiple HP E1430As, the phase parameter from any one of the HP E1430As may be used to determine the trigger delay for all of the HP E1430As. This is because the decimation counters of all the HP E1430As have been synchronized, and all HP E1430As in the group are triggered at the same time.

The value obtained by this query is added to that obtained by the [SENSe:]SWEep:OFFSet:POINts query to obtain a more accurate value for the trigger delay. This correction is for the variable portion of the trigger delay due to data packing in the FIFO and the decimation filter. This is only valid if the DSP clock is coupled to the ADC clock (the default case). This correction factor does not account for the following delays:

- Delay through the analog anti-alias filter
- Group delay through the decimation filter (frequency dependent)
- Fixed digital filter latency
- ADC trigger to SYNC line transition latency
- MAG trigger latency
- External trigger to SYNC transition latency
- Phase shift due to local oscillator mixing (in complex data mode)

[SENSe:]FILTer[:BPASs]:MODE

command/query

Selects single or multi-pass output data from the decimation filter.

Command syntax: [SENSe:]FILTer[:BPASs]:MODE (SINGle|ALL)

Example Statements: OUTPUT 70901;"sense:filter:bpass:mode all"
OUTPUT 70901;"FILT:MODE SING"

Query syntax: [SENSe:]FILTer:MODE?

Return Format: CHAR

Attribute Summary: Option: not applicable

Preset State: SING

SCPI compliance: instrument specific

Description: The decimation filter in the HP E1430A module is implemented so that the outputs of the cascaded chain of filters are time multiplexed into a single data sequence. Each filter in the cascade reduces the span by two and decimates the data stream by a factor of two. The HP E1430A can be configured to save the output of the single final pass of the filter, or the output of final pass and all previous passes (that is, those filters in the cascade with greater span). Selecting ALL saves all passes whose span is greater than or equal to the span set by `FREQ:SPAN`, whereas SINGle selects only the output of the last filter in the chain.

When ALL is selected, a 5-bit pass tag is attached to each data sample to indicate from which filter in the cascade the data originated. See the `DATA:TAG` command in this chapter for a discussion of pass tags and their placement.

[SENSe:]FREQuency:CENTer

command/query

Sets the digital local oscillator frequency.

Command syntax: [SENSe:]FREQuency:CENTer <number>
<number> ::= (NRf data) in Hertz

Example Statements: OUTPUT 70901,"sense:frequency:center 1000000"
OUTPUT 70901,"FREQ:CENT 250000"

Query syntax: [SENSe:]FREQuency:CENTer?

Return Format: NR3

Attribute Summary: Option: not applicable

Preset State: 0.0

SCPI compliance: confirmed

Description: The command sets the frequency of the digital local oscillator (LO) for frequency zooming operations. The range of values is 0.0 to F_s , where F_s is 10 MHz or 10.24 MHz, depending on option. The resolution is $9.77e-6$ Hz for $F_s = 10$ MHz and $1.0e-5$ Hz for $F_s = 10.24$ MHz.

Setting the center frequency to a non-zero value digitally mixes the time data coming from the ADC with the complex frequency of the LO, resulting in complex time data. The DATA:TYPE COMpLex command must be used to enable the module to output both the real and imaginary parts of this complex time data.

[SENSe:]FREQuency:SPAN

command/query

Sets the width of the decimation filter.

Command syntax: [SENSe:]FREQuency:SPAN <number>
<number> ::= (NRf data)

Example Statements: OUTPUT 70901,"sense:frequency:span 2MHz"
OUTPUT 70901,"FREQ:SPAN 500kHz"

Query syntax: [SENSe:]FREQuency:SPAN?

Return Format: NR3

Attribute Summary: Option: not applicable

Preset State: 4.0

SCPI compliance: confirmed

Description: This command sets the span of the output decimation filter. The decimation filter is a low-pass filter in baseband mode and a bandpass filter in zoomed mode. The HP E1430A is set to either baseband or zoomed mode with the DATA:TYPE command.

The legal values of span are descending powers of two from the maximum span in either baseband or zoomed mode. If a requested span is between two legal values, the higher legal span is set. As the span is reduced, the output sample rate is reduced through decimation. This relationship follows these formulas:

For baseband mode:

$$\text{span} = \frac{F_s}{2.56 \times 2^N} \qquad \text{output sample rate} = \frac{F_s}{2^N}$$

For zoomed mode:

$$\text{span} = \frac{F_s}{1.28 \times 2^N} \qquad \text{output sample rate} = \frac{F_s}{2^N}$$

where:

$$0 \leq n \leq 23$$

F_s = input sample frequency

[SENSe:]ROSCillator:DSP:SOURce

command/query

Set the source of the DSP clock.

Command syntax: [SENSe:]ROSCillator:DSP:SOURce ADC|INTernal

Example Statements: OUTPUT 70901;"roscillator:dsp:source int"
OUTPUT 70901;"ROSC:DSP:SOUR ADC"

Query syntax: [SENSe:]ROSCillator:DSP:SOURce?

Return Format: CHAR

Attribute Summary: Option: not applicable

Preset State: ADC

SCPI compliance: instrument specific

Description: This command selects the source of the clock for the DSP sections of the HP E1430A. Setting the source of the DSP clock to ADC selects the ADC sample clock to drive the digital sections and reduces the possibility of spurious signals due to an independent digital, resulting in better spurious specifications.

Selecting INT drives the digital sections from the internal 10 MHz (10.24 MHz) oscillator. This mode is useful whenever a slow external ADC clock is being used and the control logic would run too slowly with this external ADC clock. This mode results in degraded spurious specifications.

Note

This command will not work for controlling multiple HP E1430A's. The example on page 11-79 must be used.

[SENSe:]ROSCillator:MASTer

command/query

Enable/disable HP E1430A from driving VXI backplane with its sample clock.

Command syntax: [SENSe:]ROSCillator:MASTer ON|OFF

Example Statements: OUTPUT 70901;"roscillator:master on"
OUTPUT 70901;"ROSC:MAST OFF"

Query syntax: [SENSe:]ROSCillator:MASTer?

Return Format: CHAR

Attribute Summary: Option: not applicable

Preset State: OFF

SCPI compliance: instrument specific

Description: This command selects whether the HP E1430A module makes its local ADC clock available on the VXI backplane as the system wide ADC clock for multi-module applications. At most, one module should be programmed as a master per mainframe to avoid drive conflicts on the shared backplane clock line.

An alternative way to drive the backplane clock line is to connect the Clock Extend Input to the Clock Extend Output of a module in another mainframe containing a Master. When the clock extender is used, no modules in the slave mainframe may be programmed as a Master.

Note

This command will not work for controlling multiple HP E1430A's. The example on page 11-79 must be used.

[SENSe:]ROSCillator:SOURce

command/query

Set the source of the ADC clock.

Command syntax: [SENSe:]ROSCillator:SOURce SYSTem|INTernal|EXTernal

Example Statements: OUTPUT 70901;"roscillator:source int"
OUTPUT 70901;"ROSC:SOUR SYST"

Query syntax: [SENSe:]ROSCillator:SOURce?

Return Format: CHAR

Attribute Summary: Option: not applicable

Preset State: INT

SCPI compliance: confirmed

Description: This command selects the source of the clock for the ADC. INTernal selects the internal 10 MHz or 10.24 MHz (depending on option) clock as the ADC sample clock. EXTernal selects the External Clock BNC connector for the source of the ADC sample clock.

SYSTem selects the ADC from the VXI backplane. If the SYSTem option is specified, one HP E1430A module in the mainframe must be programmed to source its ADC clock onto the backplane using the [SENSe:]ROSCillator:MASTer command.

An individual HP E1430A can have its SYNC signal derived locally or taken from the SYNC line on the VXI backplane. Setting synchronization to INTernal or EXTernal forces the HP E1430A to use its internally generated SYNC signal, while setting it to SYSTem forces the HP E1430A to use the SYNC line from the backplane.

The SYNC signal is used to move the HP E1430A between different measurement states as well as to synchronously load the center frequency.

Note

For controlling multiple HP E1430A's the example on page 11-79 must be used or this command will not work.

[SENSe:]ROSCillator:SOURce:FREQuency command/query

Set or query the frequency of the sample clock.

Command syntax: [SENSe:]ROSCillator:SOURce:FREQuency <value>
<value> ::= NRF

Example Statements: OUTPUT 70901;"sense:roscillator:source:frequency 5 MHz"
OUTPUT 70901;"ROSC:SOUR:FREQ 100 kHz"

Query syntax: [SENSe:]ROSCillator:SOURce:FREQuency?

Return Format: NR3

Attribute Summary: Option: not applicable

Preset State: 0.0

SCPI compliance: instrument specific

Description: The command sets the frequency of the external clock that is connected via the EXT CLK connector. This value is used for all internal calculations involving sample frequency when the [SENSe:]ROSCillator:SOURce command has set the HP E1430A to the "external clock" clock mode.

The query returns 10.24 MHz or 10.00 MHz (depending on the sample frequency option) in the internal clock mode. In the external clock mode, the query returns the last value set by the [SENSe:]ROSCillator:SOURce:FREQuency command.

[SENSe:]SWEep:MODE

command/query

Select continuous or block mode data collection.

command syntax: [SENSe:]SWEep:MODE AUTO|MANual

Example Statements: OUTPUT 70901;"sense:sweep:mode auto"
OUTPUT 70901;"SWE:MODE MAN"

Query Syntax [SENSe:]SWEep:MODE?

Return Format: CHAR

Attribute Summary: Option: not applicable

Preset State: MAN

SCPI compliance: confirmed

Description: When the HP E1430A has been set to MANual mode, the module stops collecting data as soon as one block has been collected. (The size of the block is set with the [SENSe:]SWEep:POINts command.) At this time the MEAS_DONE bit in the status register is set and the module moves from the MEASURE state to the IDLE state.

When the HP E1430A has been set to AUTO mode, the module collects data continuously until its FIFO is full. At this time the MEAS_DONE bit in the status register is set and the module moves into the IDLE state. As soon as there are enough samples in the FIFO to satisfy the number of points set by the [SENSe:]SWEep:POINts command, the BLOCK_READY bit in the status register is set, signaling that data can be read out. After the data is read out, its space is freed up in the FIFO. If data is read out as fast as new data is entered into the FIFO, it is possible to run the module in a continuous mode.

[SENSe:]SWEep:OFFSet:POINts

command/query

Set the pre- and post-trigger delay.

Command syntax: [SENSe:]SWEep:OFFSet:POINts <number>
<number> ::= positive or negative integer

Example Statements: OUTPUT 70901;"sense:sweep:offset:points 1000"
OUTPUT 70901;"SWE:TIME:OFFS:POIN -100"

Query syntax: [SENSe:]SWEep:OFFSet:POINts?

Return Format: NR1

Attribute Summary: Option: not applicable
Preset State: 0
SCPI compliance: confirmed

Description: A negative number specifies a pre-trigger delay, the number of samples before the trigger event to be saved as data (if a requested pre-trigger delay is larger than the FIFO, an error will result). A positive number specifies a post-trigger delay, the number of samples to ignore after the trigger event before data collection begins.

The pre- or post-trigger delay is in terms of output samples whose rate is set by the **FREQ:SPAN** command. This rate is not necessarily the same as the input sample clock. See the **FREQ:SPAN** command for the formula to find the output sample rate.

Because of the way data is packed in the FIFO, the trigger delay must be an integral number of 8-byte groups of samples. This means that the delay must be divisible by 1, 2, or 4; depending on the data type and size set by the **DATA:TYPE** and **DATA:SIZE** commands. This is shown in the following table. (If a requested trigger delay is between two of the points allowed by this granularity, the lower legal span is set.)

Delay granularity

Data size	Data type	Delay granularity
16	real	4
16	complex	2
32	real	2
32	complex	1

This limitation applies to setting the trigger delay; you can find the actual delay between the trigger point and the first sample in the FIFO using the correction factor obtained from the [SENSe:]CORRection:TRIGger:PHASe? query.

[SENSe:]SWEep:POINts

command/query

Set the number of samples in a data block.

Command syntax: [SENSe:]SWEep:POINts <number>
<number> ::= positive integer

Example Statements: OUTPUT 70901,"sense:sweep:points 1024"
OUTPUT 70901,"SWE:POIN 8192"

Query syntax: [SENSe:]SWEep:POINts?

Return Format: NR1

Attribute Summary: Option: not applicable

Preset State: 1024

SCPI compliance: confirmed

Description: This command sets the number of sample points in a data block that are collected before the MEAS_DONE or BLOCK_READY bits in the status register are set. (See [SENSe:]SWEep:MODE to see how these status bits are set.) The relationship between the number of sample points in a block and the size in bytes of the block can be calculated using the table below:

Minimum samples in a block

Data type	Data size	Bytes per sample	Minimum number of samples in block
real	16	2	4
real	32	4	2
complex	16	4	2
complex	32	8	1

The legal values for the number of samples increases in powers of 2 from the minimum number of samples (for example: 4, 8, 16, 32, 64, 128...). If the number requested is between two legal values, the higher legal value is set.

Specifying a number less than the minimum results in the number of samples being set to the minimum. Specifying a number larger than the amount the FIFO will support results in the number of samples being set to the largest value for which the data will fit in the FIFO.

[SENSe:]VOLTage:[DC:]RANGe[:UPPer] command/query

Set the full scale range of the analog input section.

Command syntax: [SENSe:]VOLTage:[DC:]RANGe[:UPPer] <numeric>

Example Statements: OUTPUT 70901;"sense:voltage:dc:range:upper 4.0"
 OUTPUT 70901;"VOLT:RANG 1.0"

Query syntax: [SENSe:]VOLTage:[DC:]RANGe[:UPPer]?

Return Format: NR3

Attribute Summary: Option: not applicable

 Preset State: 8.0 volts

 SCPI compliance: confirmed

Description: This command sets the input range of the module. The highest range is 8.0 volts. Legal range values decrease by a factor of 2 to the lowest range of 0.0078125 volts. If a requested range is between two legal values, the higher legal range is set. Specifying a value greater than the maximum sets the range to the maximum. Specifying a value lower than the minimum sets the range to the minimum.

 An input signal that exceeds the range set will cause an ADC overload.

[SENSe:]VOLTage:[DC:]RANGe:AUTO

command

Performs auto range of analog input section.

Command syntax: [SENSe:]VOLTage:[DC:]RANGe:AUTO ONCE

Example Statements: OUTPUT 70901;"sense:voltage:dc:range:auto once"
OUTPUT 70901;"VOLT:RANG:AUTO ONCE"

Attribute Summary: Option: not applicable

Preset State: not applicable

SCPI compliance: confirmed

Description: This command performs a single auto range by starting at the lowest range and stepping up to the next range if an ADC overload is detected.

STATus:OPERation:CONDition?

query

Reads the Operational Status condition register.

Query syntax: STATus:OPERation:CONDition?

Example Statements: OUTPUT 70901;":STAT:OPERATION:COND?"
OUTPUT 70901;"stat:operation:cond?"

Return Format: NR1

Attribute Summary: Option: not applicable

Preset State: not affected by Preset

SCPI Compliance: confirmed

Description: This query returns the sum of the decimal weights of all bits currently set to 1 in the Operational Status condition register. (The decimal weight of a bit is 2^n , where n is the bit number.)

See page 11-16 for more information on the Operational Status register.

STATus:OPERation:ENABLE

command/query

Sets and queries bits in the Operational Status enable register.

Command syntax: STATus:OPERation:ENABLE <number>|<bound>
<number> ::= a real number (NRf data) limits: 0:32767
<bound> ::= MAXIMIN

Example Statements: OUTPUT 70901;"Status:Oper:Enab 96"
OUTPUT 70901;"STATUS:OPER:ENABLE 2"

Query syntax: STATus:OPERation:ENABLE?

Return Format: NR1

Attribute Summary: Option: not applicable
Preset State: not affected by Preset
SCPI Compliance: confirmed

Description: To set a single bit in the Operational Status enable register to 1, send the bit's decimal weight with this command. To set more than one bit to 1, send the sum of the decimal weights of all the bits. (The decimal weight of a bit is 2^n , where n is the bit number.)

See page 11-16 for more information on the Operational Status register.

STATus:OPERation[:EVENT]?

query

Reads and clears the Operational Status event register.

Query syntax: STATus:OPERation[:EVENT]?

Example Statements: OUTPUT 70901;":stat:oper?"
OUTPUT 70901;"Status:Oper:Event?"

Return Format: NR1

Attribute Summary: Option: not applicable

Preset State: not applicable

SCPI Compliance: confirmed

Description: This query returns the sum of the decimal weights of all bits currently set to 1 in the Operational Status event register. (The decimal weight of a bit is 2^n , where n is the bit number.)

The Operational Status event register is automatically cleared after it is read by this query. See page 11-16 for more information on the Operational Status register.

STATus:PRESet

command

Sets bits in the enable registers to their default state.

Command syntax: STATus:PRESet

Example Statements: OUTPUT 70901;"status:pres"
OUTPUT 70901;"Status:Pres"

Attribute Summary: Option: not applicable

Preset State: not applicable

SCPI Compliance: confirmed

Description: This command sets all of the enable register bits on the Questionable Status and Operational Status registers to 0.

STATus:QUEStionable:CONDition?

query

Reads and clears the Questionable Status condition register.

Query syntax: STATus:QUEStionable:CONDition?

Example Statements: OUTPUT 70901;":STAT:QUESTIONABLE:COND?"
OUTPUT 70901;"status:ques:cond?"

Return Format: NR1

Attribute Summary: Option: not applicable

Preset State: not affected by Preset

SCPI Compliance: confirmed

Description: This query returns the sum of the decimal weights of all bits currently set to 1 in the Questionable Status condition register. (The decimal weight of a bit is 2^n , where n is the bit number.)

See page 11-14 for more information on the Questionable Status register.

STATus:QUEStionable:ENABle

command/query

Sets and queries bits in the Questionable Status enable register.

Command syntax: STATus:QUEStionable:ENABle <number>|<bound>
<number> ::= a real number (NRf data) limits: 0:32767
<bound> ::= MAXIMIN

Example Statements: OUTPUT 70901;"Status:Ques:Enable 1"
OUTPUT 70901;"STAT:QUES:ENABLE 513"

Query syntax: STATus:QUEStionable:ENABle?

Return Format: NR1

Attribute Summary: Option: not applicable
Preset State: not affected by Preset
SCPI Compliance: confirmed

Description: To set a single bit in the Questionable Status enable register to 1, send the bit's decimal weight with this command. To set more than one bit to 1, send the sum of the decimal weights of all the bits. (The decimal weight of a bit is 2^n , where n is the bit number.)

All bits are initialized to 0 when the module is turned on. However, the current setting of bits is not modified when you send the *RST command.

See page 11-14 for more information on the Questionable Status register.

STATus:QUEStionable[:EVENT]?

query

Reads and clears the Questionable Status event register.

Query syntax: STATus:QUEStionable[:EVENT]?

Example Statements: OUTPUT 70901;":stat:questionable?"
OUTPUT 70901;":Stat:Ques:Event?"

Return Format: NR1

Attribute Summary: Option: not applicable

Preset State: not applicable

SCPI Compliance: confirmed

Description: This query returns the sum of the decimal weights of all bits currently set to 1 in the Questionable Status event register. (The decimal weight of a bit is 2^n , where n is the bit number.)

The Questionable Status event register is automatically cleared after it is read by this query. See page 11-14 for more information on the Questionable Status register.

SYSTem:ERRor?

query

Query the system error queue.

Query syntax: SYSTem:ERRor?

Example Statements: OUTPUT 70901;"system:error?"
OUTPUT 70901;"SYST:ERR?"

Return Format: String: <error number>, <error string>

Attribute Summary: Option: not applicable

Preset State: 0, "No error"

SCPI compliance: confirmed

Description: Each call returns the most recent error from the error queue. This error is also removed from the queue by the call. If there are no errors in the queue, '0, "No error"' is returned.

SYSTem:TIMEout

command/query

Set the system timeout.

Command syntax: SYSTem:TIMEout <number>
<number> ::= positive integer, in seconds

Example Statements: OUTPUT 70901,"system:timeout 8"
OUTPUT 70901,"SYST:TIM 4"

Query syntax: SYSTem:TIMEout?

Return Format: NR1

Attribute Summary: Option: not applicable

Preset State: 5

SCPI compliance: instrument specific

Description: The command sets the system timeout value associated with waiting for data to be ready or waiting for measurement state changes. The query returns the value of the timeout.

TRIGger[:IMMediate]

command

Trigger the HP E1430A.

Command syntax: TRIGger[:IMMediate]

Example Statements: OUTPUT 70901;"trigger:immediate"
OUTPUT 70901;"TRIG"

Attribute Summary: Option: not applicable

Preset State: not applicable

SCPI compliance: confirmed

Description: This command manually triggers the HP E1430A, moving it from the ARM state to the TRIGGER state.

TRIGger:LEVel[:ADC]

command/query

Set level for ADC triggering mode.

Command syntax: TRIGger:LEVel[:ADC] <numeric>

<numeric> ::= -1.0 to +1.0, in fraction of full scale

Example Statements: OUTPUT 70901;"trigger:level:adc 0.0"
OUTPUT 70901;"TRIG:LEV -0.5"

Query syntax: TRIGger:LEVel[:ADC]?

Return Format: NR3

Attribute Summary: Option: not applicable

Preset State: 0.0

SCPI compliance: instrument specific

Description: This command sets the voltage threshold for triggering from the ADC triggering source (see the TRIGger:SOURce command in this chapter). The number is a fraction of the ADC's full scale output (-1.0 to +1.0). Values outside that range will set the level to the nearest one of these limits.

There is a small hysteresis around the threshold in order to prevent multiple triggers from a single threshold crossing.

TRIGger:LEVel:RATio

command/query

Set level for magnitude triggering mode.

Command syntax: TRIGger:LEVel:RATio <numeric>
<numeric> ::= +3.0 -85.0 in dB from full scale

Example Statements: OUTPUT 70901;"trigger:level:ratio -4.5"
OUTPUT 70901;"TRIG:LEV:RAT -40.0"

Query syntax: TRIGger:LEVel:RATio?

Return Format: NR3

Attribute Summary: Option: not applicable

Preset State: 0.0

SCPI compliance: instrument specific

Description: This command sets the threshold for triggering from the magnitude triggering source (see the TRIGger:SOURce command in this chapter). The number is in dB from full scale of the magnitude of the complex output of the decimation filter.

A value of +3.0 dB is allowed since the real and imaginary portions of the waveform will add together. There is a 3.0 dB hysteresis around the threshold in order to prevent multiple triggers from a single threshold crossing.

TRIGger:SLOPe

command/query

Set the slope at which triggering occurs.

Command syntax: TRIGger:SLOPe POSitive|NEGative

Example Statements: OUTPUT 70901;"trigger:slope:negative"
OUTPUT 70901;"TRIG:SLOP POS"

Query syntax: TRIGger:SLOPe?

Return Format: CHAR

Attribute Summary: Option: not applicable

Preset State: POS

SCPI compliance: confirmed

Description: This command selects the trigger to occur on the rising edge (POSitive) or falling edge (NEGative) of the trigger waveform selected by the TRIGger:SOURce command.

TRIGger:SOURce

command/query

Select the source of the waveform to trigger from.

Command syntax: TRIGger:SOURce OFF|AUTO|ADC|MAGnitude|EXTernal

Example Statements: OUTPUT 70901;"trigger:source off"
OUTPUT 70901;"TRIG:SOUR ADC"

Query syntax: TRIGger:SOURce?

Return Format: CHAR

Attribute Summary: Option: not applicable

Preset State: AUTO

SCPI compliance: instrument specific

Description: When the trigger source is OFF, the HP E1430A stays in the ARM state until a *TRG or TRIGger:[IMMediate] command is issued. If the trigger source is AUTO, the HP E1430A triggers immediately upon entering the ARM state. A trigger source of EXTernal causes the HP E1430A to trigger on one of the edges of a trigger signal applied to the External Trigger connector on its front panel. This is selected by the TRIGger:SLOPe command.

Triggering on the waveform coming out of the ADC is done by selecting ADC as the source. The last triggering source is the magnitude of the complex waveform coming out of the decimation filter. It is selected by setting the source to MAGnitude.

The HP E1430A hardware samples the trigger source once every sample clock, so the trigger condition must be present for at least one sample clock in order to be recognized.

VINstrument[:CONFigure]:LBUS[:MODE]

command/query

Selects the mode in which the local bus operates.

Command syntax: VINstrument[:CONFigure]:LBUS[:MODE] <mode>

<mode> ::= GENERate|APPend|INSert|PIPeline

Example Statements: OUTPUT 70901,"vinstrument:configure:lbust:mode off"
OUTPUT 70901,"VINS:LBUS GEN"

Query syntax: VINstrument[:CONFigure]:LBUS[:MODE]?

Return Format: CHAR

Attribute Summary: Option: not applicable

Preset State: PIPeline

SCPI compliance: instrument specific

Description:

This command is used to set up single- or multiple-module systems to do data transfer via the local bus.

GENERate mode means that data generated in the HP E1430A is output on the local bus to the right.

PIPeline mode means that the module passes data from its local bus on the left to its local bus on the right. It does not output any of its own data via the local bus.

APPend mode means that the module pipelines data from right to left until the end of a local bus frame; at which time it appends its own data, sending it out to the left.

INSert mode means that the module starts in the generate mode, sends one block of data, and then switches to pipeline mode.

If the mode is set to GENERate, INSert, or APPend, data is output from the HP E1430A only if the port has been selected to be LBUS with the VINstrument[:CONFigure]:PORT command. Otherwise the local bus will remain in the PIPeline mode until selected as the data port.

VINstrument[:CONFigure]:PORT

command/query

Select which port on the HP E1430A delivers the data.

Command syntax: VINstrument[:CONFigure]:PORT LBUS|VME

Example Statements: OUTPUT 70901;"vinstrument:configure:port lbus"
OUTPUT 70901;"VINS:PORT VME"

Query syntax: VINstrument[:CONFigure]:PORT?

Return Format: CHAR

Attribute Summary: Option: not applicable

Preset State: VME

SCPI compliance: instrument specific

Description: This command sets the data output port for the HP E1430A to either the VME data output register or the local bus.

Example Program Using SCPI Commands

```

20      ! Example program for E1430A using SCPI commands.
30      !
40      ! This example is written in HP Rocky Mountain BASIC (RMB), and
50      ! expects the RMB computer to be connected by HP-IB to an E1406
60      ! Command Module in slot 0 of the VXI mainframe. Since the
70      ! E1430 is register-based, the E1430 SCPI driver must be
80      ! downloaded to the Command Module before running this program.
90      !
100     ! This example is useful for E1430 SCPI applications in other
110     ! languages:
120     !   If using Quick BASIC and the HP-IB Command Library,
130     !     change "OUTPUT" statements to CALL IOOUTPUTS.
140     !   If using C and SICL (Standard Instrument Control Library),
150     !     change "OUTPUT" statements to iprintf function calls.
160     !   If using Compiled SCPI,
170     !     change "OUTPUT" statements to INST_SEND macros.
180     !
190     !-----
200     ! Assign the IO path to the E1430. For example, use 70916 for
210     ! select code 7, Command Module HP-IB address 9, and E1430
220     ! logical address 128 (divide by 8 to get secondary address).
230     Hpib_isc=7          !Interface select code
240     E1406_addr=9        !Command module HP-IB primary address
250     E1430_la=128        !E1430 VXI Logical Address
260     ASSIGN @E1430 TO (Hpib_isc*100+E1406_addr)*100+(E1430_la DIV 8)
270     !
280     DIM Response$(100)
290     OUTPUT @E1430;"*IDN?"          !Ask for ID
300     ENTER @E1430;Response$        !Read ID response
310     PRINT Response$
320     !
330     OUTPUT @E1430;"*RST"          !Reset the E1430
340     !
350     OUTPUT @E1430;"SENSE:VOLTAGE:RANGE 2.0"  !Select 2 Vp range
360     !
370     OUTPUT @E1430;"SENSE:CORRECTION:INPUT:OFFSET" !Do Auto Zero
380     !Note: After a reset or Offset Correction, the E1430 requires
390     !20 seconds to allow ADC correction values to settle to
400     !specified accuracy. After code development, a delay should
410     !be inserted here.
420     !
430     OUTPUT @E1430;"SENSE:SWEEP:POINTS 256"  !Set block size
440     DIM Data_block(0:255)
450     !
460     OUTPUT @E1430;"SYSTEM:ERR?"          !Ask for any errors
470     ENTER @E1430;Response$
480     PRINT Response$

```

```
490  !
500  OUTPUT @E1430;"INIT:IMMEDIATE"           !Begin acquisition
510  !
520  REPEAT !loop to wait for data block ready
530     OUTPUT @E1430;"STATUS:OPERATION:CONDITION?" !get status
540     ENTER @E1430;Oper_status
550     PRINT "Operational Status Register = ";Oper_status
560  UNTIL BIT(Oper_status,8)                 !until data ready bit is set
570  !
580  OUTPUT @E1430;"FORMAT ASCII"            !select ASCII data format
590  OUTPUT @E1430;"DATA:SCALE SCALED"       !scale data to volts
600  OUTPUT @E1430;"DATA?"                  !ask for a data block
610  ENTER @E1430;Data_block(*)             !read data into array
620  !
630  PRINT "Time record samples (in Volts): "
640  FOR I=0 TO 19
650     PRINT I;" ";Data_block(I)
660  NEXT I
670  !
680  END
```

SCPI Commands to control and sync up two HP E1430A's

- Master HP E1430A:** **DIAG : REG 36, 3:** (Sets MULTI-SYNC ON, MASTER-CLOCK ON, ADC-CLOCK INT and DSP-CLOCK to ADC-CLOCK)
TRIG : SOUR :EXT: (Sets the master HP E1430 to receive its trigger source from the front panel External Trigger BNC connector)
- Slave HP E1430A's:** **DIAG : REG 36, 5:** (Sets MULTI-SYNC ON, MASTER-CLOCK OFF, ADC-CLOCK EXT and DSP-CLOCK to ADC-CLOCK)

To start the measurement, send the following SCPI commands (in order listed):

- Slave HP E1430A's:** **DIAG:REG 10,3:** (Forces the SLAVE ADC2 into the IDLE state, then transition to normal operation and wait for a SYNC pulse.)
- Master HP E1430A:** **DIAG:REG 10,1:** (Sets MASTER ADC1 into the IDLE state, then transitions to normal operation and pulls the SYNC line.)
 This should put both modules into the ARM state.

DIAG:REG 10,2: (Pulls the SYNC line on the MASTER ADC1 which in turn pulls the SYNC line on the SLAVE ADC2 and moves both modules into the TRIGGER state.)

Diagram of Clock and Timing Circuits

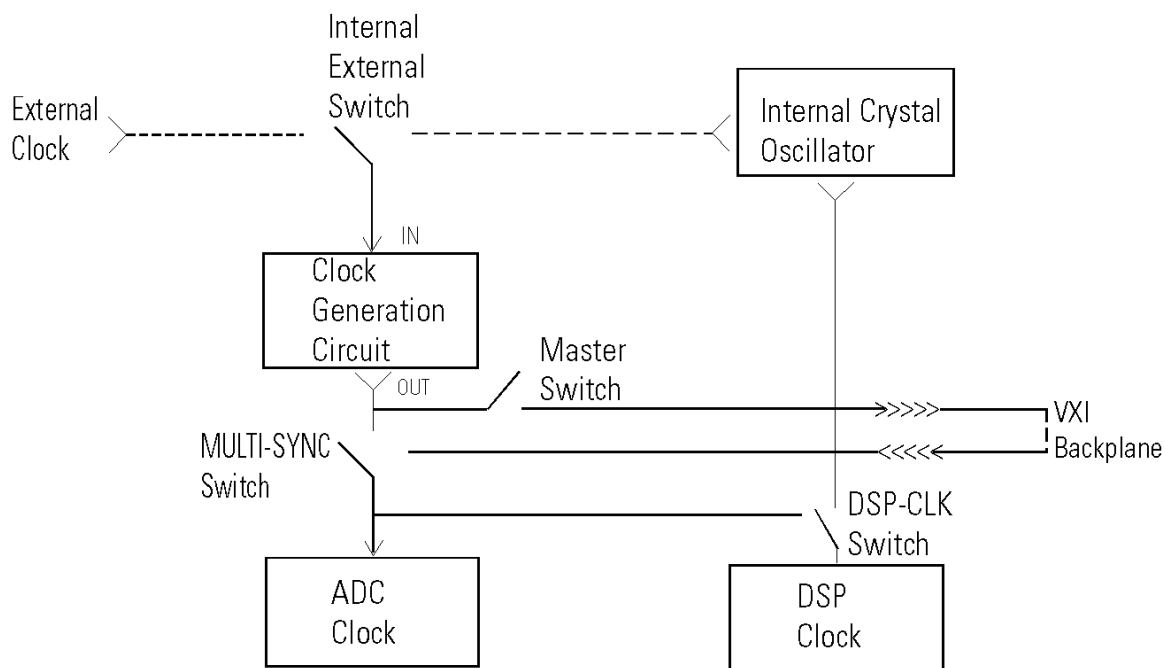

12

VXI Registers

The Control Registers

The HP E1430A module complies with the register-based VXI specification, using the 16-bit address/16-bit data (A16/D16) protocol. The table on the next page summarizes the registers.

In the table, register addresses are given as byte offsets relative to the base address $V \times 64 + 49152$, where V is the module's VXI logical address as set by the Logical Address Configuration Switches. Address locations not labeled in the table do not respond to a read or write.

Summary of registers in the HP E1430A

Address Hex Offset	Address Decimal	Read register	Write register
0	0	ID/Logical Address	
2	2	Device Type	
4	4	Status	Control
6	6		Analog Setup
8	8		Input Offset
0A	10		Measurement Control
0C	12		Data Format Control
0E	14		
10	16		
12	18		
14	20		IRQ Config 0
16	22		IRQ Config 1
18	24	Port Control	
1A	26		Trigger Setup
1C	28		Blocksize/Trigger offset high
1E	30	Subclass register	Trigger offset low
20	32		
22	34	Data register	
24	36		Timing Setup
26	38		ADC Control
28	40	CNTLAT[7:0] + SHIFT	Passout
2A	42	CNTLAT[15:8] + SHIFT	Reset Filter
2C	44	CNTLAT[23:16] + SHIFT	Capture decimation
2E	46	CNTLAT[24] + SHIFT	
30	48	Temp Coarse[10:3]	
32	50	Temp Coarse[2:0]	
34	52	Temp Fine[28:21]	
36	54	Temp Fine[20:13]	
38	56	Temp Fine[12:5]	
3A	58	Temp Fine[4:0]	
3C	60	(Unspecified)	Zoom Control
3E	62	(Unspecified)	LO Transfer

ID/Logical Address Register

The ID/Logical Address register is summarized in the table below. This register is defined in the VXI specification.

ID/Logical Address register bit definitions (Read Address 00H)

Bit position	Field label	Description
11-0	Manufacturer ID	Returns (FFF) Hex to indicate HP
13-12	Address Space	Returns (11) to indicate A16 addressing only
15-14	Device Class	Returns (11) to indicate register based

Device Type Register

The Device Type register is summarized in the table below. This register is defined in the VXI specification.

Device Type register bit definitions (read address 02H)

Bit position	Field label	Description
11-0	Model Code	Returns (1C6) Hex to indicate HP E1430A
15-12	Required Memory	Returns (0000)

Status Register

The following paragraphs describe the fields of the Status register. The register is summarized in the table below. Bits 2, 3, 14, and 15 are as defined in the VXI specification.

Status register bit definitions (read address 04H)

Bit position	Field label	Description
1-0	STATE	Measurement loop state
2	PASSED	Always set to (1)
3	READY	Indicates module is ready to accept commands
5-4	MEMSIZE	Indicates which memory size option is installed
6	10.24 MHz	Indicates optional 10.24 MHz internal clock
7	SYNC_VALID	Indicates when SYNC change has taken effect
8	READ_VALID	At least one 16 bit data word available to read
9	BLOCK_READY	FIFO contains at least one block of data
10	ARMED	Module is armed and waiting for a trigger
11	MEASURE_DONE	Module has stopped taking new data
12	OVERLOAD	Signal exceeded range since last status read
13	ADCERROR	Hardware fault in ADC since last status read
14	MODID*	Indicates when module is selected by P2MODID
15	A24/A32	Active

STATE

This field indicates the current state of the measurement loop. See the section “Measurement Control Register” for more information about the states.

STATE

Value of field	Meaning
0	IDLE
1	ARM
2	MEASURE
3	TRIGGER

READY

This bit is set after completion of a power-on reset.

MEMSIZE

This field indicates the memory size in the module:

MEMSIZE

Value of field	Meaning
0	8 MByte
1	16 MByte
2	32 MByte
3	64 MByte

10.24 MHz

A (1) in this bit indicates that the optional 10.24 MHz internal oscillator is installed instead of the standard 10 MHz.

SYNC_VALID

A (1) in this bit indicates that a change in the SYNC output has produced its desired effect.

READ_VALID

This flag is set whenever there is a valid data word available to be read via the Data register. After a reset this bit may be set in error. Its data is only valid after a measurement has been armed.

BLOCK_READY

This flag is set whenever the size of the data in the FIFO is equal to or greater than the blocksize register. This bit is useful for non-block mode, to indicate that a block of data may be transferred without fear of running out of data, thereby holding up the Local bus or VME bus. In continuous mode, check this bit before reading data. In BLOCK mode, use MEASURE DONE instead of BLOCK_READY since at power on the BLOCK_READY bit will not be valid until a measurement has been armed. After a reset this bit may be set in error. Its data is only valid after a measurement has been armed.

ARMED

This flag is set whenever the module is in the Trigger state, or it is in the Arm state and has satisfied its pre-trigger requirement. When this flag is set, the module releases the VXI SYNC line. When all modules release the line, and it goes high, all modules go to the Trigger state.

MEASURE DONE

This flag is set whenever the module is in the Idle state. It is also set whenever the module is in the Measure state and data collection has stopped due to FIFO overflow or end of block. (The end of block condition applies in block mode only.) When this flag is set, the module releases the VXI SYNC line. When all modules release the line, and it goes high, all modules go to the Idle state.

OVERLOAD

This flag is set whenever the ADC converts a sample that exceeds the range of the ADC. The flag is cleared when the Status register is read. Repeated ADC errors may indicate that the module should be recalibrated.

ADCERROR

This flag is set whenever a hardware error is detected in the ADC. The flag is cleared whenever the Status register is read.

MODID*

A (1) in this field indicates that the module is not selected via the P2 MODID line. A (0) indicates that the module is selected by a high state on the P2 MODID line.

Control Register

The following paragraphs describe the fields of the Control register. The register is summarized in the table below. This register is defined in the VXI specification.

VXI Control register (Write Address 04H)

Bit position	Field label	Description
0	Reset	VXI bit, 1 = module reset,
1	Sysfail Inhibit	VXI bit, always interpreted as a 1 in the HP E1430A
2-14	Unused	
15	A24/A32 Active	VXI bit, always interpreted as a 0 in the HP E1430A

RESET

Setting this bit high (1) is equivalent to writing (0) to all the writable control registers except for the VXI Control register (04 Hex). This bit must be set to (0) to enable other registers to be programmed.

Caution

After a RESET, the ADC control register must be programmed to fully calibrated mode for at least 20 seconds to achieve specified distortion and noise performance.

Setting the RESET bit also resets the decimation counter to zero and the zoom center frequency to 0 Hz with a constant phase of 54.77461 degrees. This destroys synchronous operation with other modules in a multi-module system. To re-establish synchronous operation see the description of the Measurement Control register.

SYSFAIL INHIBIT

This bit is defined as part of the VXI specification to allow modules the flexibility to drive the SYSFAIL* hardware line in the VXI utility bus. In the HP E1430A, this bit is always interpreted as a 1, indicating that the HP E1430A never asserts SYSFAIL*.

A24/A32 ACTIVE

This bit is defined by the VXI specification to enable modules to support larger memory spaces. Since the HP E1430A only supports the A16 protocol, this bit is always interpreted as (0).

Analog Setup Register

The following paragraphs describe the fields of the Analog Setup register. The register is summarized in the table below.

Caution

Writing changes to this register may cause a momentary improper termination of the input connector during the relay switching time.

Analog Setup register (Write Address 06H)

Bit position	Field label	Description
3-0	RANGE	Input range control
4	DC	Selects AC or DC input coupling
5	FILTER	Determines whether the analog anti-alias filter is used
6	FLOAT	Selects single-ended or pseudo-floating input
7	INPUT	Selects input from connector or shorted input
15-8		Unused

RANGE

The four range control bits each affect an attenuator or gain stage. Use the settings in the table on the following page for optimum noise, distortion, and power handling characteristics.

The first two columns of the table represent:

- “ADC Clipping Voltage” — the voltage at which the ADC will clip. However, because of overshoot in the digital filter responses, it is possible to see valid transient digital outputs which exceed the ADC clipping level even without observing an ADC overload. These transients may approach the full range of the selected 16 or 32 bit two’s complement outputs.
- “Scale Factor” — To convert a measured result which is in two’s complement integer form to absolute voltage, multiply by the range scale factor and divide by the data width; 2^{31} (for 32-bit data) or 2^{15} (for 16-bit data). See the example on the following page.

Because the low noise auxiliary amplifier is inverting, the scale factor for the lowest three ranges is negative. The magnitude of the scale factor is 2.307175 times the ADC clipping voltage.

Example of a 32-bit full scale voltage reading from a register read of register 0022H:

Input voltage: 8 volts

Range: ± 8 volts

Data width: 32 bit

Scale factor for 8 volt range: 18.4574 (see following table).

- 1** Set the phase of the local oscillator to zero and arm the E1430A.
- 2** Read register 0022H twice. First read= 3779AH Second read= A780H
- 3** Convert the two readings to decimal. Reading #1= 14,201
Reading #2= 42,880
- 4** Multiply the first reading by 2^{16} and add it to the second reading:
 $930,742,272 + 42,880 = 930,785,152$
- 5** Mutiply the results of step 4 by the range scale factor and divide by 2^{31} :
 $930,785,125 \times 18.4574 / 2^{31} = 8$ volts

With a 16 bit ADC set to its maximum value you would expect 7FFFH, not 3779H. Between the ADC and the digital filters is a data scaler which scales the data down by a factor of 0.4334. If you multiply 32,767 (7FFFH) \times 0.4334 you will get 14,201 (3779H) or $-32,768$ (8000H) \times 0.4334 you will get $-14,202$ (C886).

Range

ADC Clipping Voltage	Scale Factor	Bit 3 18 dB Gain (inverting)	Bit 2 24 dB Atten.	Bit 1 12 dB Atten.	Bit 0 6 dB Atten.
± 8 V	18.4574	0	1	1	1
± 4 V	9.2287	0	1	1	0
± 2 V	4.61435	0	1	0	1
± 1 V	2.30718	0	1	0	0
± 0.5 V	1.52588	0	0	1	1
± 0.25 V	0.576794	0	0	1	0
± 0.125 V	0.288397	0	0	0	1
± 62.5 mV	0.144198	0	0	0	0
± 31.25 mV	-72.0992	1	0	1	0
± 15.625 mV	-36.0496	1	0	0	1
± 7.8125 mV	-18.2481	1	0	0	0

DC

When this bit is (1), the input is dc coupled to the 50 ohm input. When the bit is (0), a 0.2uF capacitor is put in series with the input connector.

FILTER

When this bit is (0), an analog low-pass filter is applied to the input signal to eliminate aliasing effects when the signal is sampled by the ADC. When the bit is (1), the analog alias filter is bypassed.

FLOAT

When this bit is (0), the barrel of the analog input connector is isolated from chassis ground by 50 ohms in parallel with 0.04 uF. This provides sufficient impedance to suppress low frequency ground loop pickup. The maximum common mode voltage is limited to 0.7 V by a pair of 3-ampere diodes. When this bit is (1), the input connector barrel is connected to chassis ground.

INPUT

When this bit is (0), the differential input is disconnected from the input connector and is shorted to 0 V in order to provide a reference to calibrate the analog dc offset. When the bit is (1), the input is taken from the analog input connector. In either case, the input connector remains differentially terminated into 50 ohms.

Input Offset Register

This register programs a dc offset into the ADC after the analog attenuators.

The offset is approximately $\frac{V}{2} \left(\frac{N}{2^{11}} - 1 \right)$ where:

N = an unsigned integer specified by the lower 12 bits of the Input Offset register

V = the Scale Factor for the range (see the "Range" table on the previous page)

You can use the Input Offset register to compensate for the dc offset of the input amplifiers. Iterate the input offset setting until zero volts dc is read while the input is grounded.

The Measurement Control Register

The following paragraphs describe the fields of the Control register. The register is summarized in the table below.

Using the Measurement Control register you can control the sequence involved in arming and triggering the module and in collecting data.

Measurement Control Register (Write Address 0AH)

Bit position	Field label	Description
1-0	OPCODE	Sets measurement loop mode
2	PULL_SYNC	Pulls backplane SYNC line low
3	ADC DISABLE	1 turns off ADC data
15-4		Unused

OPCODE

This field controls the measurement loop. The value of these bits sets the measurement state and defines the SYNC line as follows:

OPCODE definitions

Value of bits	Measurement state	SYNC definition
(00)	idle	A falling transition resets the DSP section of the module. This is used to synchronize the decimation filters.
(01)	idle	A falling transition triggers the DSP section to do a register load/read as defined in the Zoom register and Filter register sections.
(10)	normal operating condition	SYNC transitions cause the module to cycle through the measurement loop.
(11)	idle, then normal operating condition	The measurement loop is forced to the idle state, then the OPCODE is changed to (10) and SYNC transitions cycle through the loop.

PULL_SYNC

Writing a (1) to this bit causes the module to pull the VXI backplane SYNC line low. Writing a (0) to this bit releases the SYNC line which allows it to go high whenever all modules release it. This allows the controller to manipulate the SYNC line and cause measurement loop state transitions.

ADC DISABLE

Writing a (1) in this bit disables the ADC from sending data to the digital mixer in the zoom processor. You must do this before loading the zoom phase register. After loading the zoom phase register, you can re-enable the ADC by writing (0) into this bit.

The Measurement Loop

The following diagram shows the measurement loop states of the HP E1430A module. The module changes from one state to another when the SYNC line changes (high to low or low to high.) These transitions are synchronous with the ADC sample clock. In synchronous systems with more than one HP E1430A module, all the ADC clocks and SYNC lines are driven from the VXI backplane, which allows all modules to change state at the same time.

You can force a transition from idle to arm (or from trigger to measure) by programming the Measurement Control register to drive the SYNC line low. Each of the measurement states is described in more detail below.

This diagram applies only when the Measurement Control register's opcode field is set to 2 (normal operating mode). Otherwise the module is forced to the idle state and the SYNC line is redefined.

Measurement loop states

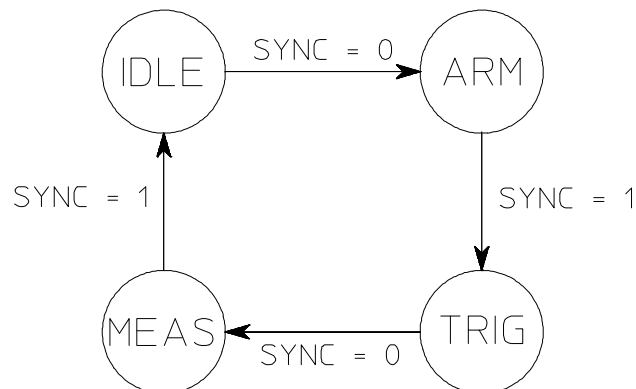

IDLE STATE In the idle state the ADC, zoom, and digital filters operate according to their own control registers and according to the OPCODE in the Measurement Control register. No new data is written into the FIFO. Data from the FIFO is available (via the backplane or local bus port) as long as there is data available from the previous measurement. The module can be forced to the idle state by writing an OPCODE $\neq 2$ in the Measurement Control register.

The module exits the idle state, and goes to the arm state, on a high-to-low transition of the SYNC line. The SYNC line can be pulled by writing to the Measurement Control register.

ARM STATE On entering the arm state, the module discards all data from previous measurements and begins saving new data in its FIFO. It holds down the SYNC line until enough data has been collected to satisfy the pre-trigger requirement, then it releases the SYNC line. When all modules have released the SYNC line, the SYNC line goes high and the modules go to the trigger state.

TRIGGER STATE In the trigger state, the module continues to collect data into the FIFO, discarding any data prior to the pre-trigger time.

The module exits the trigger state on a high-to-low transition of the SYNC line. The SYNC line can be pulled by any module which encounters a trigger condition and is programmed to pull SYNC; or it can be pulled by a controller writing to the Measurement Control register.

MEASURE STATE In the measure state, the module continues to collect data. The module also presents data from the FIFO to the selected output port, making it available for the controller to read.

The module holds SYNC low as long as it is collecting data. In block mode, the module stops when it has collected a block of data after the trigger (including pre- and post-trigger offsets). In the continuous mode, the module stops when the FIFO overflows.

When it stops collecting data, the module releases the SYNC line. When all modules have released the SYNC line, the SYNC line goes high and the modules go to the idle state.

The module can be forced to the idle state by writing to the Measurement Control register. An example of this procedure would be to force all the modules in a multi-module system to the idle state when one of the modules has overflowed its memory and stopped collecting data. The system would then be ready for re-arming and re-starting.

While the module is in the measure state, the FIFO manages both writes and reads. Writing takes precedence over reading; if the data rate is high into the FIFO, it may not be possible to read data from the FIFO. In this case, continuous (non-block) mode may not be useful since writing dominates until the FIFO is filled (and the module goes to the idle state). The data is still valid, but continuous data transfer is not possible. For continuous data transfer, the data output rate (as determined by the decimation and data format setup) must be $2 \times F$ bytes per second or lower, where F is the programmed DSP clock rate (usually 10 MHz).

Data Format Control Register

The following paragraphs describe the fields of the Data Format Control register. The register is summarized in the table below.

Data Format Control Register (Write Address 0CH)

Bit position	Field label	Description
0	BLOCK MODE	Selects Block or continuous data mode
1	DATA TYPE	Selects real or complex data
2	PRECISION	Selects 16/32 bit precision
3	DECIMATE	Turns on/off 2x decimation
8-4	PASSOUT	Selects which filter or filters (passes) are output
9	MULTI-PASS	Selects multi- or single-filter output
10	PASSTAG	Selects tag locations for multi-filter (multi-pass) mode (24-bit or 32-bit)
11	APPEND STATUS	Turns on appending of error and overload bits
15-12		Unused

BLOCK MODE

A (1) in this bit sets data transfers to block mode. In block mode, the module stops collecting data as soon as one block of data has been collected after a trigger.

A (0) in this bit sets continuous mode. In continuous mode, the module continues to collect data, generating multiple blocks of data, until the FIFO overflows or until the module is programmed to the idle state.

DATA TYPE

Low (0) specifies that all data transferred is real. High (1) specifies that all data transferred is complex.

PRECISION

Low (0) selects 16-bit data precision. High (1) selects 32-bit data precision. This precision applies to both real and complex data.

DECIMATE

Decimate mode reduces the output of the digital filters by a factor of two in order to save memory. (The data out of the filters is oversampled by nearly a factor of two relative to the Nyquist rate.) When the DECIMATE bit is (1), every other sample is saved; the rest are discarded. When the DECIMATE bit is (0), all samples are saved.

PASSOUT

The module filters the signal using a cascaded series of digital filters. You can select the bandwidth (amount of filtering) by designating which filter to take the output from. The five PASSOUT bits specify which filter (pass) is used as output. The resulting filter bandwidth is $F_s/2^{N+1}$ where F_s is the ADC sample rate and N is the number specified by PASSOUT. The valid range for N is 0 to 23.

MULTI-PASS

This bit selects single-filter or multi-filter mode. If the MULTI-PASS bit is (0), the module saves only the output of a single filter (the one designated by PASSOUT). If the MULTI-PASS bit is (1), the module saves the output of all the filters beyond the one designated by PASSOUT. Also, when MULTI-PASS mode is on, the module adds a 5-bit passtag to each sample to indicate which filter the sample came from.

PASSTAG

If MULTI-PASS is set to (1), the module adds a passtag to each data sample. The passtag is a 5-bit number showing which filter the data is from. The PASSTAG control bit determines where the passtag is placed within the data sample. (If MULTI-PASS is set to (0), PASSTAG control bit has no effect.)

The 5-bit passtag replaces five of the original data bits for each data sample (except in 16-bit precision real mode, where there is room to insert the passtag as an extra 16-bit word). The passtag is positioned to have a minimum effect on the data accuracy.

For controllers with 32-bit data precision, the PASSTAG control bit should be set to (0); the passtag then replaces the five least significant data bits. For controllers with 24-bit data precision, the PASSTAG control bit should be set to (1); the passtag is then positioned in the top 24 bits. See "Data Formats" below for a table showing the tag location for each combination of data type and precision.

APPEND STATUS

When the APPEND STATUS bit is high (1), extra bytes are appended to the end of each transfer block. Within the least significant byte of the extra bytes, two bits are defined.

Bit 0 of the least significant appended byte indicates whether an ADC overload occurred during the collection of the data block. A (1) in bit 0 means an overload occurred. Bit 1 of this byte has the same definition as the ADCERROR bit of the measurement status byte; a (1) means a hardware error has been detected in the ADC. When this appended byte is output via the VXI backplane, the byte is located in the lower eight bits of the 16-bit VXI data transfer; the upper byte is undefined. When the appended byte is output via the local bus, the byte is located in the lower 8 bits of a 32-bit Local Bus transfer; the upper 24 bits (3 bytes) are undefined.

Data Formats

Each data sample generates a packet of bytes as shown in the table below. If data is output via the 16-bit data register (address 22 hex) the bytes are sent out in pairs (0-1, 2-3, 4-5, 6-7).

Output Data Byte Sequence

MULTI-PASS	PASSTA G (X = 0 or 1)	Type	Precision	Format r = Real Data, i = Imaginary Data, p = Passtag, z = zeros
0	X	Real	16	r[31:24] r[23:16] (rrrrrrr rrrrrrr)
0	X	Real	32	r[31:24] r[23:16] r[15:8] r[7:0] (rrrrrrr rrrrrrr rrrrrrr rrrrrrr)
0	X	Complex	16	r[31:24] r[23:16] i[15:8] i[7:0] (rrrrrrr rrrrrrr iiiiii iiiiii)
0	X	Complex	32	r[63:56] r[55:48] r[47:40] r[39:32] i[31:24] i[23:16] i[15:8] i[7:0] (rrrrrrr rrrrrrr rrrrrrr rrrrrrr iiiiii iiiiii iiiiii iiiiii)
1	X	Real	16	r[31:24] r[23:16] z[15:8] z[7:5] p[4:0] (rrrrrrr rrrrrrr 00000000 000ppppp)
1	0	Real	32	r[31:24] r[23:16] r[15:8] r[7:5] p[4:0] (rrrrrrr rrrrrrr rrrrrrr rrrppppp)
1	1	Real	32	r[31:24] r[23:16] r[15:13] p[12:8] r[7:0] (rrrrrrr rrrrrrr rrrppppp rrrrrrr)
1	X	Complex	16	r[31:24] r[23:16] i[15:8] i[7:5] p[4:0] (rrrrrrr rrrrrrr iiiiii iiipppp)
1	0	Complex	32	r[63:56] r[55:48] r[47:40] r[39:32] i[31:24] i[23:16] i[15:8] i[7:5] p[4:0] (rrrrrrr rrrrrrr rrrrrrr rrrrrrr iiiiii iiiiii iiiiii iiipppp)
1	1	Complex	32	r[63:56] r[55:48] r[47:40] r[39:32] i[31:24] i[23:16] i[15:13] p[12:8] i[7:0] (rrrrrrr rrrrrrr rrrrrrr rrrrrrr iiiiii iiiiii iiipppp iiiiii)

IRQ Config 0 Register

The following paragraphs describe the fields of the IRQ Config 0 register. This is a write-only register which controls interrupts.

When the module generates an interrupt based on the settings of the IRQ Config 0 register, the subsequent interrupt-acknowledge clears the register. It must be reprogrammed to cause another interrupt.

The IRQ Config 0 register is summarized in the table below.

IRQ Config 0 register (Write Address 14H)

Bit position	Field label	Description
2-0	PRIORITY	VME Interrupt Priority Level
7-3		Unused
8	READ VALID	At least one 16-bit data word available to read
9	BLOCK_READY	FIFO contains at least one block of data
10	ARMED	Module is armed and waiting for a trigger
11	MEASURE DONE	Module has stopped taking new data
12	OVERLOAD	Signal exceeded range since last status read
13	ADCERROR	Hardware fault in ADC since last status read
15-14		Unused

PRIORITY

This field selects which of the seven priority interrupt lines (1-7) is asserted by the interrupt. A zero in this field turns off the interrupt.

MASK

Bits 8-13 of the IRQ Config 0 register act as a mask for the corresponding bits of the Status register. If any one of the bits is a (1) both in the mask and in the Status register then an interrupt is generated. The priority of the interrupt is set by the PRIORITY field.

IRQ Config 1 Register

This register (Write Address 16H) is identical to the IRQ Config 0 register except that it controls a second independent interrupt.

Port Control Register

The HP E1430A can send its output either to the VXI Databus or to the Local Bus.

When data is output via the VXI Databus, each HP E1430A manages its output independently. The controller can read the data from the modules in any order. Since the HP E1430A supports only 16-bit reads over the VXI Databus, each sample of the signal may take more than one word to transmit. For 32-bit data, the most significant word is transmitted first. For complex data, the real part is transmitted first, then the imaginary part.

When data is output via the Local Bus, all physically adjacent HP E1430A modules multiplex their data. Each module transmits an entire transfer block each time it has access to the local bus. Since the local bus supports only 8-bit data transfers, each sample of the signal takes multiple bytes to transmit. The most significant byte is transmitted first. For complex data, the real part is transmitted first, then the imaginary part.

You can program some modules to transmit on the LOCAL BUS and others to transmit on the VXI Databus. A module transmitting to the VXI Databus can be programmed to pass the local bus traffic through without appending its own data. The controller is responsible for keeping track of which blocks of data are multiplexed onto the Local Bus and in what order the data arrives. (See the LBus Mode field of the Port Control register for more information about multiplexing data on the Local Bus.)

The following paragraphs describe the fields of the Port Control register. The register is summarized in the table below.

Port Control register (Read/Write Address 18H)

Bit position	Field label	Fixed value (if any)	Meaning
0	LBus Enable		Enables local bus
1	LBus Pipe		Forces local bus to pipeline data, if enabled
4-2		000	unused
5	Send Port		selects between VME bus/Local bus
7-6		01	unused
9-8	LBus Mode		Selects Local Bus mode
15-10		111111	Unused

LBUS ENABLE

A (1) in this bit enables the local bus as the data output port (rather than the VXI Data register). See also LBUS PIPE, SEND PORT, and LBUS MODE below.

LBUS PIPE

A (0) indicates that the SEND PORT and LBUS MODE fields control the local bus transfers. A (1) forces the local bus to passthrough mode, passing local bus data from the module on its left to the module on its right. The LBUS PIPE field only applies if LBUS ENABLE is subsequently set to (1).

SEND PORT

A (0) in this field indicates that the data will be sent out via the local bus port. A (1) indicates that the data will be sent out the data register. The actual data path depends on the values of the other port control register fields (see table below).

LBUS MODE

The LBUS MODE field specifies the local bus mode. The modes are defined in the table below. Changes in mode and pipe should be made with LBUS ENABLE set low, then written high.

The LBUS MODE field only applies if LBUS PIPE is (0) and SEND PORT is local bus (0) prior to setting LBUS ENABLE to (1).

Port Control Field Interactions

LBUS ENABLE	LBUS PIPE	SEND PORT	LBUS MODE	Data Path
1	0	0	x	Data output via local bus as determined by LBUS MODE (see table below)
1	0	1	x	Data output via VXI data register
1	1	0	x	Module disabled. Data passed through from module on left to module on right
1	1	1	x	Module disabled. Avoid this mode
0	x	0	x	This is the setup mode to be used prior to setting LBUS ENABLE to (1)
0	x	1	x	Data output via VXI data register

LBUS MODE definitions

Value of bits	Local bus mode	Definition
(00)	generate mode	The module is always a data generator; it does not allow data to be pipelined through from the module to its left.
(01)	append mode	The module pipelines data until the end of a local bus frame and then appends its block of data to the frame.
(10)	insert mode	The module starts in generate mode, then changes to pipeline mode after it has sent a block of data.
(11)	pipeline mode	The module passes data through from the module on its left; it does not generate data.

Trigger Setup Register

This register controls when the module initiates a trigger event. The module can generate a trigger only when it is in the Start measurement state and the SYNC line is high (indicating that all modules are ready for a trigger).

The following paragraphs describe the fields of the Trigger Setup register. The register is summarized in the table below.

Trigger Setup register bit definitions (Write Address 1AH)

Bit position	Field label	Description
0-7	TRIGLEVEL	Sets trigger threshold (<i>n</i>)
8	AUTOTRIG	(0) Activates automatic triggering (free run)
9	SLOPE	Selects positive or negative trigger slope
10	TRIG_INTERNAL	Selects internal or external trigger
11	TRIGSOURCE	Selects between two internal trigger sources
12	TRIGOFF	Disables trigger generation by this module
15-13		Unused

TRIGLEVEL

TRIGLEVEL is an 8-bit unsigned integer which sets the trigger threshold level for internal trigger sources.

For the magnitude trigger source (TRIGSOURCE bit = 1):

$$\text{threshold level} = R \times 2^{(n-237)/16}$$

For the ADC trigger source: (TRIGSOURCE bit = 0)

$$\text{threshold level} = R(n/128-1)$$

where R is the input range ADC clipping level and n is the number specified by TRIGLEVEL. For the lowest three ranges, R is negative due to the inverting amplifier used on those ranges (see the "Analog Setup Register" section in this chapter).

There is a fixed trigger hysteresis to prevent triggering on the wrong slope in the presence of noise. The hysteresis is equivalent to two counts of n. A setting of $n < 2$ with positive slope or $n > 253$ with negative slope would never allow triggers to occur.

AUTOTRIG

If the AUTOTRIG bit is cleared (0), the module automatically generates a trigger as soon as it enters the trigger state.

If AUTOTRIG is (1), auto triggering is turned off and the module triggers as defined by the SLOPE, TRIG_INTERNAL, and TRIGSOURCE bits.

AUTOTRIG does not apply if the TRIGOFF bit is (1); that is, triggering is disabled.

SLOPE

If the SLOPE bit is (0), a positive-going crossing of the trigger threshold generates a trigger event. If the SLOPE bit is (1), a negative-going crossing of the threshold generates a trigger event. To avoid triggering on the wrong slope, hysteresis is provided for internal triggering thresholds (see TRIGLEVEL). Note that the inverting gain on the three lowest input ranges reverses the trigger slope with respect to the input signal.

TRIG_INTERNAL

If TRIG_INTERNAL is (0), the trigger source is the external TTL trigger input on the front panel. If TRIG_INTERNAL is (1), the trigger source is one of the two internal trigger sources (see TRIGSOURCE).

TRIGSOURCE

If the TRIGSOURCE bit is (1), the trigger source is the magnitude of the complex signal from the filter pass selected in the Passout register. This is called the magnitude internal trigger source.

If the TRIGSOURCE bit is (0), the trigger source is the unfiltered data straight from the ADC. This is called the ADC trigger source. This can only be selected if the TRIG_INTERNAL bit is set to (1).

TRIGOFF

If TRIGOFF is (1), the module is disabled from generating triggers. When the module is in this mode, triggers must be generated by other modules or by the controller. (The controller can trigger by pulling the SYNC line while the module is in the trigger measurement state.) If TRIGOFF is (0), the module can generate triggers.

Blocksize/Trigger Offset High register

The Blocksize/Trigger Offset High register controls the size of the data transfer blocks and designates the “first” data sample in the FIFO (relative to the trigger signal).

When a trigger occurs the module enters the measurement state. The module then moves the “first” data sample from the FIFO to the output port. After each sample has been read, the module moves the next sample until the end of the transfer block is reached. Then, if the BLOCK MODE bit in the Data Format Control register is (1), the data transfer stops until the module is armed and triggered again. If BLOCK MODE is (0), the module is in continuous mode and the transfer of the next block starts immediately.

The following paragraphs describe the fields of the Blocksize/Trigger Offset High register. The register is summarized in the table below.

Blocksize/Trigger Offset High register (Write Address 1CH)

Bit position	Field label	Description
6-0	Trigger Offset high	Upper seven bits of 23-bit trigger offset
8-7		Unused
9	Pre-Post Trig	Selects between pre- or post-trigger delay
14-10	Block size	Block size = 8×2^N bytes, $0 \leq N \leq 20$
15	Re-read On	Enables cyclic reading of the same data

TRIGGER OFFSET HIGH

These seven bits contain the high-order bits of the 23-bit unsigned integer trigger offset. The low-order 16 bits are in the Trigger Offset Low register.

The length of the trigger offset in terms of output sample periods is:

$$\text{trigger offset} = \text{PACK} \times M$$

where: M = the trigger offset number (a 23-bit unsigned binary integer)

PACK = 1 for 32-bit complex outputs

PACK = 2 for 16-bit complex or 32-bit real outputs

PACK = 4 for 16-bit real outputs

There is a potential uncertainty in the timing between the desired trigger time and effective trigger time on the order of PACK samples. If this trigger timing uncertainty is critical, use the information in the CNTLAT registers to remove it.

PRE-POST TRIG

If the PRE-POST TRIG bit is (0), the trigger offset is a post-trigger offset; that is, the beginning of the output data block is later in time than the trigger event. If the PRE-POST TRIG bit is (1), the offset is a pre-trigger offset and the beginning of the block is earlier than the trigger event.

Since pre-triggering requires access to data stored prior to the trigger, the offset is limited by the depth of the physical memory and the number of bytes needed to store the selected data type and precision. If the pre-trigger offset exceeds the FIFO memory depth, incorrect data will result. The number of bytes per sample is given in the BLOCKSIZE field description.

BLOCKSIZE

This field sets the length of a transfer data block (the block size). In block mode, this determines how much data will be collected each time the measurement is triggered. In continuous mode, the block size determines when the "block ready" flag is set in the Status register. When data is output via the local bus, the block size determines how much data will be sent for each data flow cycle on the local bus.

The block size, in bytes, is:

$$\text{block size} = 8 \times 2^N \text{ bytes}$$

where number specified by BLOCKSIZE. N is a binary integer in the range 0-20.

To determine the number of data samples contained in a transfer block, divide the block size by the number of bytes per sample. Real 16-bit data requires two bytes per sample (four bytes in multipass mode). Real 32-bit or complex 16-bit data requires four bytes per sample. Complex 32-bit data requires eight bytes per sample.

RE-READ ON

The re-read mode allows repeated post processing of full data blocks. It might be used, for example, in a host computer which does not have sufficient memory to store the entire data record. If the RE-READ ON bit is (1), the FIFO is limited to one blocksize. Data reads which try to read beyond the end of the data block wrap around to the beginning of a block. This allows the host to re-read the same data as many times as desired.

The minimum block size with re-read on is 16,384 bytes. Thus, the blocksize field of the blocksize/trigger offset register must be ≤ 11 .

If the RE-READ bit is (0), the module uses the entire FIFO depth. In this mode, trying to read beyond the end of the available data causes a bus error.

Subclass Register

The Subclass register defined is the VXI Extended device specification. It is a read-only register which indicates that this module conforms to an HP subclass standard. The following table lists the output of this register and its meaning.

Subclass Register (Read Address 1EH)

Bit position	Field label	Output	Meaning
11-0	Manufacturer ID	111111111111	Hewlett-Packard
14-12	Manuf. Subclass	111	Unspecified
15	Subclass type	0	Manufacturer specific subclass

Trigger Offset Low Register

The Trigger Offset Low register (Write Address 1EH) specifies the low order 16 bits of the 25-bit trigger offset. For a description of the trigger offset see "Blocksize/Trigger Offset register" on page 9-25 .

Data Register

When the module is programmed to use the VXI backplane for data output, the data becomes available to the controller at the Data register (Read Address 22H). After the register is read, the module loads it with the next available word from the FIFO.

The Data register is empty whenever the FIFO has no more new data or when the module is programmed for local bus output. If the controller tries to read from the Data register when it is empty, it will either "hang the bus" or cause a bus error, depending on the controller. (The controller will not receive a "DTAK" response.)

Each read of this register transfers two bytes of data. The data sequence is described in the "Data Format Control Register" section in this chapter. The first byte is the upper byte of each 16-bit transfer.

Timing Setup Register

The HP E1430A module uses two clock signals, the ADC clock and the DSP clock. The ADC clock drives the sampling analog-to-digital-converter. The DSP clock is the system clock for the digital signal processing hardware. It determines the maximum processing speed at which the module can handle data from the ADC.

The DSP clock rate must be at least as high as the ADC clock rate. One way to ensure this is to set the ADC clock to drive the DSP clock. To synchronize multiple modules, the ADC clock from one HP E1430A can be sent to other HP E1430A modules via the VXI backplane. These clock settings are controlled by the Timing Setup register.

The following paragraphs describe the fields of the Timing Setup register. The register is summarized in the table below.

Timing Setup Register (Write Address 24H)

Bit position	Field label	Description
0	Multi-module Sync	Turns on multi-module synchronization
1	Master	Enables module to drive ADC clock on VXI backplane
2	ADC Clock Source	Selects local ADC clock source (10 MHz or External)
3	DSP Clock Source	Selects 10 MHz or ADC clock for the DSP clock
5-4		Unused
6	ADC_LIMIT	Forces ADC output to full scale for diagnostics
7	Track Only	Used for diagnostics of ADC Track/Hold
15-8		Unused

MULTI-MODULE SYNC

If the MULTI-MODULE SYNC bit is (1), the module uses the ADC clock it receives on the VXI backplane. It also uses the SYNC line for arming, triggering, decimation, and initialization of zoom LO phase; synchronous with other modules. This bit overrides the clock selection in the ADC CLOCK SOURCE bit. This bit needs to be set even if you are master to the system.

If the MULTI-MODULE SYNC bit is (0), the sync functions and the ADC clock must come from within the module or from the External Clock connector (see "ADC CLOCK SOURCE").

MASTER

If the MASTER bit is (1), the module makes its local ADC clock available on the VXI backplane as the system-wide ADC clock. The source of the local ADC clock is determined by the ADC CLOCK SOURCE bit. To avoid conflicts on the backplane clock line, no more than one module should be programmed as a master.

An HP E1430A in one mainframe can drive the clock line in another mainframe. To do this connect the Clock Extend Output connector of the master module to the Clock Extend Input of a module in the second mainframe. No modules in the second mainframe should be programmed as master.

If the MASTER bit is (0), this module does not drive the VXI backplane clock.

ADC CLOCK SOURCE

If the ADC CLOCK SOURCE bit is (0), the local ADC clock is the internal 10 MHz clock within the module. If this bit is (1), the "local" ADC clock comes from the BNC External Clock input connector. Note that if the MULTI-MODULE SYNC bit is (1) this bit makes no difference because the clock line on the VXI backplane will be used.

DSP CLOCK SOURCE

The DSP clock controls timing for digital signal processing, memory, and control logic. If the DSP CLOCK SOURCE bit is (0), the DSP is clocked from the ADC clock. This reduces the chance of spurious signals due to an independent clock.

If the DSP CLOCK SOURCE bit is (1), the DSP is clocked from the internal 10 MHz oscillator. This is useful when a slow external ADC clock is used and the control logic would run too slowly from the ADC clock. A disadvantage of this is degraded spurious specifications.

Caution

If the external ADC clock rate is less than 1 MHz, set the DSP clock source bit to (1) to use the internal 10 MHz oscillator. Clocking the DSP at less than 1 MHz can result in loss of data in the dynamic RAMS.

ADC_LIMIT

This bit is used for diagnostics. If the ADC_LIMIT bit is set to (1), the ADC1 output goes to negative full scale. If ADCDIAG = 30 is set in the ADC Control register, this provides a negative full scale DC input to the zoom/digital filtering so that a memory test can be performed.

The ADC_LIMIT bit should be (0) for normal operation.

TRACK ONLY

This bit is used for hardware diagnostic testing. While TRACK ONLY is set to (1), the track and hold amplifier remains in the track mode.

The TRACK ONLY bit should be (0) for normal operation.

ADC Control Register

This write register is used to access non-standard modes of operation for the analog-to-digital converter.

The following paragraphs describe the fields of the ADC Control register. The register is summarized in the table below.

ADC Control register (Write Address 26H)

Bit position	Field label	Description
4-0	ADCDIAG	Selects ADC outputs for diagnostics
7-5	ADCMODE	Selects ADC calibration modes
15-8	Unused	

ADCDIAG

These five control bits form an integer, N, which selects various outputs from the ADC. In normal operation (N = 0), the ADC output is the combined result of both the first and second pass conversion. However, either pass can be output separately. Selections are also available to read out individual entries of the ADC error tables which are used for calibration purposes. These values are useful in determining the accuracy of the DACs and the gain accuracy of ADC2.

ADCDIAG Output Selection for Diagnostics

N	Output Selection
0	NORMAL Output
1-9	DAC3, bit N-1 error accumulator
10-19	DAC2, bit N-10 error accumulator
20-28	DAC1, bit N-20 error accumulator
29	Gain error accumulator
30	ADC1, First pass conversion
31	ADC2, Second pass conversion

ADCMODE

These three control bits form an integer, M, used to select the various control modes of the ADC. Typically, only the reset mode (M = 0) and normal mode (M = 7) are used (except for diagnostics). All modes are listed here for completeness.

Caution

After a RESET, the ADC control register must be programmed to fully calibrated mode for at least 20 seconds to achieve specified distortion and noise performance.

ADCMODE Selection

M	ADC Mode
0	RESET, use once at power up
1	Uncalibrated 2-pass conversion
2	Random dither applied to second pass
3	Second pass gain correction + dither
4	DAC error correction + dither
5	Gain/DAC correction w/o update to errors
6	Gain/DAC correction w/o update to Gain error
7	NORMAL, fully calibrated

CNTLAT+SHIFT

The exact amount of trigger delay depends on the value in the trigger offset register (which you can program) plus other factors such as the granularity of the output sample intervals and the packing of data into memory. If you do not require precise trigger timing, these additional variables can be ignored. However, if you need to know the precise trigger time you can calculate it (after the trigger has occurred) using the information in the four CNTLAT+SHIFT registers.

Calculating trigger delay

To calculate the total trigger delay in terms of output sample periods, use the following procedure. The parameters used are: CNTLAT, ALT_CNTLAT and SHIFT from the CNTLAT+SHIFT register; DATA_TYPE, PRECISION, DECIMATE, and PASSOUT from the data format control register; PRE-POST TRIG and TRIGGER OFFSET from the Trigger Offset registers.

The table below shows the location of the bits of the parameter CNTLAT: (CNTLAT is a positive integer.)

CNTLAT+SHIFT (Read Addresses 28H-2EH)

Address	Bit position	Field label	Description
28H	7-0	CNTLAT[7:0]	Lower eight bits of CNTLAT
28H	9-8	SHIFT	Indicates trigger shift due to sample packing
28H	10	ALT_CNTLAT	Alternate CNTLAT value in wide bandwidths
2AH	7-0	CNTLAT[15:8]	2nd eight bits of CNTLAT
2CH	7-0	CNTLAT[23:16]	3rd eight bits of CNTLAT
2EH	0	CNTLAT[24]	Most significant bit of CNTLAT

The delay from the trigger to the first output sample in terms of output sample periods is:

$$\text{DELAY} = \frac{8 \times (\text{SIGN} \times \text{TRIG_OFFSET} + \text{CA}) - 2 \times \text{SHIFT}}{\text{BYTES_PER_SAMPLE}} + \text{CB} + \text{CC} + \text{FINE}$$

Where:

$$\text{SIGN} = 1 - 2 \times \text{PRE_POST_TRIG}$$

$$\text{BYTES_PER_SAMPLE} = 2^{1+\text{PRECISION}+\text{DATA_TYPE}}$$

$$\text{IN_PER_OUT} = \frac{8 \times 2^{\text{PASSOUT}+\text{DECIMATE}}}{\text{BYTES_PER_SAMPLE}}$$

$$\text{RATE} = 2^{\text{PASSOUT} + \text{DECIMATE}}$$

$$\text{TRATE} = \begin{cases} 0 & , \text{PASSOUT} = 0 \\ 2^{\text{PASSOUT} - 1} & , \text{PASSOUT} > 0 \end{cases}$$

$$\text{CNT} = \begin{cases} \text{DECIMATE} \times \text{ALT_CNTLAT} & , \text{PASSOUT} = 0 \\ \text{CNTLAT} \bmod \text{RATE} & , \text{PASSOUT} > 0 \end{cases}$$

$$\text{FINE} = \begin{cases} \frac{\text{CNT} - 2}{\text{RATE}} & , \text{PASSOUT} = 0 \\ 1 - \frac{\text{CNT} + 2 - \text{TRATE} \times \text{DECIMATE}}{\text{RATE}} & , \text{PASSOUT} > 0 \end{cases}$$

$$\text{CB} = \begin{cases} 0 & , \text{CNT} \leq \text{RATE} - \text{TRATE} \\ 1 & , \text{CNT} > \text{RATE} - \text{TRATE} \end{cases}$$

$$\text{CC} = \begin{cases} -1 & , \text{PASSOUT} > 4 \text{ and } \left(\text{CNT} - 1 + \frac{\text{RATE}}{2^{\text{DECIMATE}}} \right) \bmod \text{RATE} < 32 \\ 0 & , \text{otherwise} \end{cases}$$

CA can be determined from the following table (shaded means “don’t care”):

TRIG OFFSET	PRE POST TRIG	PASSOUT	IN PER OUT	DECIMATE	SHIFT	CNT	CA		
> 0	1						1		
	0	0	1					1	
			2	0	2			1	
				1			0	1	
			> 2	0	0			-1	
				1	0			1	-1
		1	2					1	1
		1, 2, 3, 4	> 2			0	(RATE - TRATE + 1) mod RATE	1	
	> 4				0	(RATE - TRATE + 33) mod RATE	1		
	All other conditions							0	

Passout Register

The lower five bits of the Passout register form an integer, N, which is used to turn the Decimation filters on or off and to select the magnitude triggering filter bandwidth. The Analog, Zoom, and Decimation filters can be independently turned on or off. However, the Analog and Zoom filters should be on (to maintain alias protection) if the Decimation filters are to be used effectively.

PASSOUT Register (Write Address 28H)

N	Action Caused
0	Disables Decimation filters. Output of Zoom filter is passed through at SAMPCLK rate.
1-24	Identifies complex filter bandwidth for magnitude triggering as $F_s/2^{N+1}$, where F_s = ADC sample rate.
25-31	Not valid, yields unspecified result

Filter Reset “Register”

A write to this address (Write Address 2AH) clears all state variables in all the Decimation filters. This is equivalent to running the filters for an infinite time with 0's into the filter chain. The counter which controls the decimation pattern is not affected. This is not really a register because the data bus bits are ignored.

Decimation Capture “Register”

A write to this address (Write Address 2CH) copies the current state of the decimation counter into CNTLAT which can be read to determine the pattern of interleaving of outputs of all Decimation filters into a single data sequence. This is not really a register because the data bus bits are ignored.

Zoom (Frequency Shifting)

For frequency shifting, the module multiplies the data sequence by the complex exponential sequence:

$$\cos(\omega_n + \phi_0) + j \sin(\omega_n + \phi_0).$$

To compute the sequence of values for $\omega_n + \phi_0$, the module uses the Phase and Frequency registers. The value in the Frequency register is a digital representation of ω . The value in the Phase register is a digital representation of $\omega_n + \phi_0$. For each sample, the module increments the Phase register by value of the Frequency register.

The Phase and Frequency registers cannot be accessed directly. However, they can be accessed by way of two temporary storage registers, Temp Coarse and Temp Fine. See “Programming the Zoom frequency and phase registers” on page 9-40 for more information.

Temp Coarse Register

The Temp Coarse register is 11 bits wide and is accessed in two byte-wide pieces. Although each byte-wide piece is read/written using D16 accesses, the upper byte is ignored. The lower 3 bits of the Temp Coarse register are in bits 5-7 at address 32H. The other five bits at address 32H return zeros with a read operation, and are ignored in a write operation.

The Temp Coarse register is a temporary storage register which can be transferred to/from the working Frequency or Phase registers. See “Programming the Zoom frequency and phase registers” on page 9-40 .

Temp Fine Register

This 29-bit register is accessed via four read/write operations at address locations 34H, 36H, 38H, and 3AH. The upper byte of the 16-bit accesses to these registers is ignored. The lower 3 bits of the least significant byte at address 3AH return zeros with a read operation, and are ignored in a write operation.

The Temp Fine register is a temporary storage register that can be transferred to/from the working Frequency or Phase registers. See “Programming the Zoom frequency and phase registers” on page 9-40

Zoom Control Register

Data written to this register controls zoom operations according to the tables below. After data is written to the register, the action occurs when one of the following conditions is met:

- A write is made to the LO transfer “register.”
- The measurement loop is in the Trigger State and the SYNC line is pulled low (a trigger occurs).
- The Measurement Control register OP CODE is 01 and a falling transition is encountered on the SYNC line.

The following paragraphs describe the fields of the Zoom Control register. The register is summarized in the table below.

Zoom Control Register (Write Address 3CH)

Bit position	Field label	Description
3-0	Opcode	Selects transfer mode for Temp Coarse and Temp Fine
4	Filter	Enables 2x lowpass digital filters
5		Unused
6	Clear	Clears lowpass filters
7	Reset	Resets zoom to initialized state

OPCODE

These four bits control transfers between the temporary registers (Temp Coarse and Temp Fine) and the working registers (Frequency and Phase). The transfer occurs at the next trigger event. See “Programming the Zoom frequency and phase registers” on page 9-40 for more information.

Control register opcode definitions

Opcode (decimal)	Opcode (binary)	Store/Recall	Temporary Register	Working Register
0	0000	NOP		
1	0001	Store	Temp Coarse/Temp Fine	Frequency/Phase
2	0010	Recall	Temp Coarse	Frequency
3	0011	Recall	Temp Coarse	Phase
4	0100	Recall	Temp Fine	Frequency
5	0101	Recall	Temp Fine	Phase
6	0110	Recall	Temp Coarse/Temp Fine	Frequency
7	0111	Recall	Temp Coarse/Temp Fine	Phase
8	1000	Store	Temp Coarse	Frequency/Phase
9	1001	Store	Temp Fine	Frequency/Phase
10	1010	Store	Temp Coarse	Frequency
11	1011	Store	Temp Coarse	Phase
12	1100	Store	Temp Fine	Frequency
13	1101	Store	Temp Fine	Phase
14	1110	Store	Temp Coarse/Temp Fine	Frequency
15	1111	Store	Temp Coarse/Temp Fine	Phase

FILTER

If the FILTER bit is (1), the complex result of the Zoom operation is sent through a low pass filter. The passband of the filter is nominally $-F_s/4$ to $+F_s/4$. If the decimation filters are used, this filter is normally turned on to avoid aliasing due to sample rate reduction. If the FILTER bit is (0), this filter is bypassed.

CLEAR

If the CLEAR bit is (1), the lowpass filters are cleared to zero. The clear occurs at the next trigger event, at which time this bit itself is also cleared.

RESET

If the RESET bit is (1), the next high-to-low transition of the SYNC line initializes the zoom function. The initialized state is:

- Zero center frequency
- 54.77461 constant phase
- no filtering
- filter cleared
- zoom control register reset to zero.

LO Transfer “Register ”

This is not really a register because the data bus bits are ignored. A write to this address (Write Address 62) initiates a transfer of data from the temporary registers (Temp Coarse and Temp Fine) to the Frequency and Phase registers, or vice-versa. The type of transfer is indicated by OPCODE in the Zoom Control register. The transfer occurs on the next DSP clock cycle after the write occurs. An LO transfer will also occur whenever the module is armed and a trigger occurs.

Programming the Zoom frequency and phase registers

The information in this section is for programming the registers of the HP E1485A directly. You can also access the Zoom frequency and phase functions using the HP E1485A Software Library.

The Phase and Frequency registers cannot be accessed directly. However, they can be accessed by way of two temporary storage registers, Temp Coarse and Temp Fine. The Temp Coarse register is implemented in two 8-bit registers and the Temp Fine register in four 8-bit registers as shown in the following table:

Zoom temporary registers

Hex address	Decimal address	Name
30	48	Temp Coarse[10:3]
32	50	Temp Coarse[2:0]
34	52	Temp Fine[28:21]
36	54	Temp Fine[20:13]
38	56	Temp Fine[12:5]
3A	58	Temp Fine[4:0]

The following examples show how to select the numbers to load into these 8-bit registers.

Example 3-1: Programming a zoom frequency

- 1 Select a desired frequency. For this example we will use 100 kHz.
- 2 Note the sample ADC frequency. For this example we will use 10 MHz.
- 3 Divide the desired frequency by the ADC sample frequency.

$$\frac{F_d}{F_s} = \frac{100 \text{ kHz}}{10 \text{ MHz}} = 0.01$$

- 4 Multiply the result in step 3 by 2^{11} (2048)

$$0.01 \times 2048 = 20.48$$

In the following steps, the “20” will be loaded into the Temp Coarse register and the “0.48” will be loaded into the Temp Fine register.

- 5 Divide the integer part of the result in step 4 by 2^3 (8) and note the remainder.

$$\frac{20}{8} = 2, \text{ remainder } 4$$

- 6 Load the integer result (in this example “2”, binary “0000 0010”) into the Temp Coarse[10:3] register.
- 7 Multiply the remainder in step 5 by 2^5 (32).

$$4 \times 32 = 128$$

- 8 Load the result (in this example, “128,” binary “1000 0000”) into the Temp Coarse[2:0] register.

The result of steps 5 and 6 is to load decimal “20” (binary “10100”) into the overall Temp Coarse register.

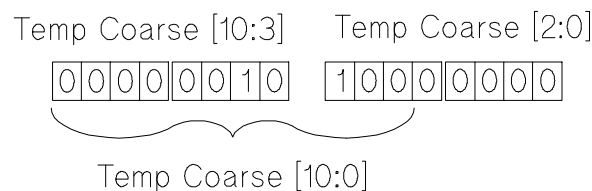

- 9 Multiply the fractional part of the result in step 4 by 500,000,000.

$$0.48 \times 500,000,000 = 240,000,000$$

- 10** Divide the result in step 7 by 2^{21} (2,097,152) and note the remainder.

$$\frac{240,000,000}{2,097,152} = 114, \text{ remainder } 924,672$$

- 11** Load the result (in this example “114”, binary “0111 0010”) into the Temp Fine[28:21] register.

- 12** Divide the remainder from step 8 by 2^{13} (8192) and note the remainder.

$$\frac{924,672}{8192} = 112, \text{ remainder } 7,168$$

- 13** Load the result (in this example “112”, binary “0111 0000”) into the Temp Fine[20:13] register.

- 14** Divide the remainder from step 9 by 2^5 (32) and note the remainder.

$$\frac{7,168}{32} = 224, \text{ remainder } 0$$

- 15** Load the result (in this example “224”, binary “1110 0000”) into the Temp Fine[12:5] register.

- 16** Multiply the remainder from step 9 by 2^3 (8).

$$0 \times 8 = 0$$

- 17** Load the result (in this example “0”, binary “0000 0000”) into the Temp Fine[4:0] register.

The result of steps 7 through 11 is to load decimal “240,000,000” (binary “1110 0100 1110 0001 1100 0000 0000”) into the overall Temp Fine register.

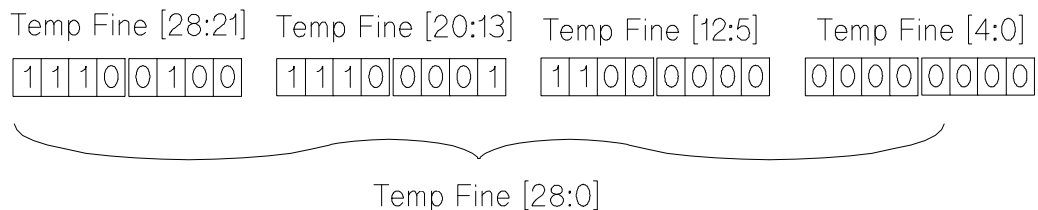

- 18** Load the Zoom Control register with decimal 14 (binary 0000 1110). This loads the OPCODE field with the code to transfer data from Temp Coarse and Temp Fine to the Frequency register.
- 19** Write to the LO Transfer register to trigger the transfer. (The transfer can also be triggered by the SYNC line.)

Example 3-2: Programming a zoom phase

- 1 Write a (1) to the ADC DISABLE bit of the measurement control register. This disables the ADC from sending data to the digital mixer in the zoom processor.
- 2 Select a desired phase. For this example we will use 90° ($\pi/2$ radians).
- 3 Divide the desired phase by 360° (2π radians).

$$\frac{\phi_d}{2\pi} = \frac{90^\circ}{360^\circ} = 0.25$$

- 4 Multiply the result in step 2 by 2^{11} (2048)

$$0.25 \times 2048 = 512.0$$

- 5 Load the integer part of the result in step 3 ("512" in this example) into the Temp Coarse[10:3] and Temp Coarse[2:0] registers. Use the same procedure as in steps 5 and 6 of the frequency example above.
- 6 Load the fractional part of the result in step 3 ("0" in this example) into the Temp Fine[28:21], Temp Fine[20:13], Temp Fine[12:5], and Temp Fine[4:0] registers. Use the same procedure as in steps 7 through 11 of the frequency example above.
- 7 Load the Zoom Control register with decimal 15 (binary 0000 1111). This loads the OPCODE field with the code to transfer data from Temp Coarse and Temp Fine to the Phase register.
- 8 Write to the LO Transfer register to trigger the transfer. (The transfer can also be triggered by the SYNC line.)
- 9 Write a (0) to the ADC DISABLE bit of the measurement control register to re-enable the ADC.

Index

A

- A24/A32 ACTIVE control register 12-8
- ABORt 11-32
- abort measurement 10-2
- AC coupling 11-43
- access LED 8-2
- accessories iv
- accuracy, specifications 2-11
- ADC
 - control register 12-30
 - DSP clock source 11-52
 - get clock 10-25
 - get trigger level 10-70
 - set clock 10-25
 - set trigger level 10-70
 - trigger level 11-71
- ADC clock source 11-54
 - timing setup register 12-29
- ADC DISABLE control register 12-13
- ADC_LIMIT setup register 12-29
- ADCDIAG control register 12-31
- ADCERROR status register 12-7
- ADCMODE control register 12-32
- address
 - register 10-14
- adjustments 4-2
- ALL 11-49
- analog
 - configuring input 9-7
 - input 8-2
 - input specifications 2-10
 - set input 10-26
 - setup register 12-9
- anti-alias filter 7-2, 11-44
 - get filter 10-28
 - set filter 10-28
- APPend (local bus mode) 11-75
- append status
 - control register 12-17
 - get status 10-29
 - set status 10-29
- arm
 - initialize 11-42
 - module 10-3
 - state 11-42, 11-70, 12-14
 - transition from idle 12-13
 - waiting for ARM bit 11-16
- ARMED status register 12-7
- ASCII format 11-41
- assistance 10
- *CLS 11-19
- *ESE 11-20
- *ESR? 11-21
- *IDN? 11-22
- *OPC 11-23
- *OPC? 11-23
- *OPT? 11-24
- *RST 11-25
- *SRE 11-26
- *STB? 11-27
- *TRG 11-28
- *TST? 11-29
- *WAI 11-30
- AUTO 11-56
- AUTO (auto range) 10-4, 11-60
- auto zero 10-4
- AUTOTRIG setup register 12-24
- AYD option iv

B

- backdating 6-2
- backplane connections 8-4
- bandwidth
 - decimation 10-44
 - trigger 10-44
- binary format 11-41
- block diagram and description 7-2 - 7-9
- BLOCK MODE
 - blocksize 12-26
 - data format control register 12-15
 - measurement state 12-14

- selecting 11-56
- using 12-7
- with trigger 12-25

BLOCK_READY status register 12-7

Blocksize

- get blocksize 10-30
- set blocksize 10-30
- trigger offset high register 12-25
- trigger offset register 12-26

BPASs 11-49

C

C interface libraries

- alphabetical listing 9-12 - 9-15
- category listing 9-7 - 9-11
- compiling program 9-3
- debugging 9-4
- errors, list of 10-81
- example program 9-3
- initialization 9-7
- installing 1-6
- linking program 9-3
- multiple mainframes 9-5

C-SCPI driver, installing 1-7

calculating trigger delay 12-33

calibration, commands 9-11

CENTer 11-50

CLEAR zoom control register 12-39

Clk Out 8-2

clock

- ADC source 11-54
- DSP source 11-52
- AYD option iv
- extender input 8-3
- external 8-2
- generation 7-7
- get DSP clock 10-53
- get sample frequency (1a) 10-64
- set DSP clock 10-53
- set master mode 10-32
- set mode 10-34
- set sample frequency (1a) 10-64
- specifications 2-16

*CLS 11-19

CNTLAT+SHIFT control register 12-33

command reference, SCPI

- conventions 11-5
- symbols 11-4
- syntax descriptions 11-6

common mode, adjusting and measuring 4-3

COMPLex 11-38

CONDition 11-61, 11-65

condition register 11-7

- operational status 11-61
- questionable status 11-65

CONFigure 11-75 - 11-76

continuous mode 11-56

control registers 7-9, 12-2, 12-8

CORRection 11-47 - 11-48

coupling

- get coupling 10-36
- set coupling 10-36

COUPLing, AC or DC 11-43

D

data

- get mode 10-39
- get port 10-40
- get reread 10-41
- get size 10-42
- get type 10-43
- post processing 9-11
- set mode 10-39
- set port 10-40
- set reread 10-41
- set size 10-42
- set type 10-43

data format 9-4

- commands 9-8
- control register 12-15
- formatting and FIFO memory 7-5
- multi-pass and passtag 11-36, 12-16, 12-18
- set format 10-37

data output 7-6

data register 12-27

Data size 11-33, 11-35

data transfer bus 8-4

DATA TYPE control register 12-15

data, reading 9-9

DATA:SCALE 11-34

DATA:SIZE 11-35

DATA:TAG 11-36

DATA:TRAIler 11-37

DATA:TYPE 11-38

DATA:WRAP 11-39

DATA[:DATA] 11-33

DC

- analog setup register 12-11
- autorange 11-60
- coupling 11-43

- setting full scale range 11-59
- debug level 10-7
- debugging 9-4
 - commands 9-11
- DECIMATE data control register 12-15
- decimation
 - filtering 7-4, 11-51
 - filtering commands 9-4
 - get bandwidth 10-44
 - get output 10-49
 - get passtag 10-50
 - get state 10-52
 - set bandwidth 10-44
 - set filter 10-46
 - set output 10-49
 - set passtag 10-50
 - set state 10-52
- decimation filtering 9-4
- declaration of conformity 9
- default logical address 1-3
- delay 11-48, 11-57
 - get trigger 10-68
 - set trigger 10-68
- device reset 11-25
- device type register 12-4
- DIAGnostic:REGister 11-40
- Diagnostics 10-9
 - commands 9-11
- display register 10-7
- driver
 - installing C library interface 1-6
 - installing C-SCPI 1-7
 - installing SCPI 1-8
- DSP
 - clock source 11-52
 - clock source setup register 12-29
 - get clock 10-53
 - set clock 10-53
- DTB arbitration bus 8-4
- dynamic range specifications 2-14

E

- elapsed time 11-48
- ENABLE 11-62, 11-66
- enable register 11-8
 - operational status 11-62
 - questionable status 11-66
- ^ END 11-5
- End or Identify (EOI) 11-5
- equipment, test 2-2, 2-4
- ERRor 11-68

errors

- C interface library 10-81
 - get string 10-7
 - print errors 10-7
- *ESE 11-20
- *ESR? 11-21
- EVENTt 11-63, 11-67
- event register 11-8
 - operational status 11-63
 - questionable status 11-67
- example program 11-77
 - HP-UX environment 9-3
- exchange module 5-3
- Ext Clk 8-2
- Ext Trg TTL 8-2
- EXTernal (ADC clock source) 11-54
- external clock input 8-2
- external connections 8-2

F

- fifo
 - block data size 10-13
 - data point size 10-13
 - get size 10-13
 - max size 10-13
- FIFO memory 7-5
- filter 11-44, 11-49
 - analog setup register 12-11
 - get data 10-11
 - zoom control register 12-39
- filter reset “register” 12-35
- filter, anti-alias 11-44
- filtering specifications 2-12
- firmware; version 10
- FLOat 11-45
- FLOAT analog setup register 12-11
- float32; read data 10-19
- FORMat 11-41
- format, data 11-36
- frequency 11-50 - 11-51
 - get center 10-31
 - set center 10-31
- front-panel description 8-2
- full scale range 11-59

G

- general specifications 2-19
- GENerate (local bus mode) 11-75
- ground 8-4, 11-45

H

- hardware reference 12-1

- help 10
- HP E1430A
 - identification 11-22
 - option configuration 11-24
 - register sets 11-12 - 11-17
- HP-IB commands
 - troubleshooting using 3-2
- I**
- I/O; initialize driver 10-18
- ID/logical address register 12-4
- identifying the HP E1430A 11-22
- IDLE state
 - ABORt 11-32
 - initialize to arm 11-42
 - measurement control register 12-13
 - moving from measure to idle 11-56
- *IDN 11-22
- IEEE 488.1 standard 11-2
- IEEE 488.2 standard 11-2
- IMMediate (initialize) 11-42
- IMMediate (trigger) 11-70
- incoming inspection 1-2
- initialize
 - C-library 9-7
 - I/O driver 10-18
- INITialize[:IMMediate] 11-42
- input
 - amplifier 7-2
 - analog setup register 12-11
 - autozero 11-47
 - get high 10-54
 - get low 10-54
 - get offset 10-56
 - offset register 12-11
 - set high 10-54 - 10-55
 - set low 10-54
 - set offset 10-56
- input channel
 - programming multiple 11-6
- INPut:COUPling 11-43
- INPut:FILTer[:LPASs][:STATE] 11-44
- INPut:LOW 11-45
- INPut:OFFSet 11-46
- INSert (local bus mode) 11-75
- install
 - C interface library 1-6
 - C-SCPI driver 1-7
 - downloadable SCPI 1-8
 - HP E1430A 1-3
- INTernal (ADC clock source) 11-54

- INTernal (DSP clock source) 11-52
- interrupt
 - get mask 10-57
 - get priority 10-57
 - set interrupt 10-57
 - set mask 10-57
 - set priority 10-57
- Interrupts 9-10
- IRQ Config 0 Register 12-19
- IRQ Config 1 Register 12-19
- L**
- lbus 11-75
 - get mode 10-59
 - set mode 10-59
- LBUS (port) 11-76
- LBUS ENABLE control register 12-21
- LBUS MODE control register 12-21
- LBUS PIPE control register 12-21
- LEVel 11-71 - 11-72
- line feed character (NL) 11-5
- LO transfer “register” 12-39
- local bus 8-5
 - modes 11-75
 - logic level 1-3
- local oscillator 11-50
- logical address, setting 1-3
- LOW 11-45
- LPASs 11-44
- M**
- magnitude triggering mode 11-72
- MANual 11-56
- manufacturers’ code 5-3
- MASK IRQ config 0 register 12-19
- MASTER
 - clock 11-53
 - timing setup register 12-29
- MAV bit 11-13
- MEASURE DONE status register 12-7
- MEASURE state 11-56, 12-14
- measurement
 - abort 10-2
 - C library commands 9-9
 - channel grouping 11-6
 - multiple mainframes 9-5
- measurement (example program) 11-77
- measurement control register 12-12
- measurement data
 - operational status register 11-16
 - questionable 11-14

- SYSTEM:TIMEout 11-69
- measurement loop 12-13
- measurement loop states 12-13
- MEMSIZE status register 12-6
- message available bit 11-13
- message, termination 11-5
- MODE 11-49, 11-56
- MODE (local bus) 11-75
- MODID* status register 12-7
- module
 - arm 10-3
 - controlling multiple 11-79
 - create group 10-5 - 10-6
 - delete all groups 10-5
 - delete group 10-5 - 10-6
 - display state 10-7
 - get state 10-7
 - replacing 3-5, 5-3
 - reset 10-23
 - sync up multiple 11-79
 - trigger 10-78
- module options with *OPT? 11-24
- module, installing 1-3
- MULTI-MODULE SYNC setup register 12-28
- multi-pass 11-36
 - data format control register 12-16
 - output data formats 11-36
 - selecting 11-49
- MULTI_SYNC
 - controlling multiple modules 11-79
- MXI interface 9-3

N
new line character (NL) 11-5

O
OFFSet 11-46 - 11-47, 11-57
ONCE (auto range) 11-60
*OPC 11-23
*OPC? 11-23
OPCODE

- measurement control register 12-12
- zoom control register 12-38

 OPERation 11-61 - 11-63
operational status register 11-16
operational status register set

- condition register 11-61
- enable register 11-62
- event register 11-63

 *OPT? 11-24
option AYD iv

- option configuration query 11-24
- options iv
- oscillator, local 11-50
- output data byte sequence 12-18
- overlapped command
 - completion of 11-23
 - processing 11-30
- overload LED 8-2
- OVERLOAD status register 12-7

P
PACKed (binary format) 11-41
pass tag 11-36
PASSOUT

- and trigger source 12-24
- data format control register 12-16
- passout register 12-35
- summary 12-15

 passtag

- control register 12-16
- get decimation 10-50
- set decimation 10-50
- summary 12-15

 performance tests 2-2
phase 11-48

- trigger 10-17

 PIPEline (local bus mode) 11-75
POINTs 11-57 - 11-58
PORT

- control register 12-20
- LBUS ENABLE 12-21
- LBUS MODE 12-21
- LBUS PIPE 12-21
- selection of 11-76

 post-trigger delay 11-57
power supplies 8-4
PRE-POST TRIG offset register 12-26
pre-trigger delay 11-57
PRECISION

- data format control register 12-15
- passtag 12-16

 preset

- setting bits 11-64
- status 11-64

 priority interrupt bus 8-4
PRIORITY IRQ config 0 register 12-19
problem; help with 10
program (example) 11-77
program message terminators 11-5
programming

- specifications 2-18

- zoom frequency (example) 12-41
- zoom frequency/phase register 12-40
- zoom phase (example) 12-43
- PULL_SYNC control register 12-12

Q

- QUESTionable 11-65 - 11-67
- questionable status register 11-14
- Questionable Status register set
 - condition register 11-65
 - enable register 11-66
 - event register 11-67

R

- range
 - analog input auto range 11-60
 - analog setup register 12-9
 - get 10-62
 - get logical address (la) 10-62
 - set 10-62
 - set logical address (la) 10-62
 - setting full scale 11-59
- RATio 11-72
- RAW mode 11-34
- re-read mode 11-39
- RE-READ ON offset register 12-26
- read
 - float32 data 10-19
 - raw data 10-19
 - register card 10-79
 - register image 10-79
- read a register 11-40
- read data 11-33
- READ VALID status register 12-6
- READY status register 12-6
- REAL 11-38
- register 11-40
 - get address 10-14
 - read card 10-79
 - read image 10-79
 - write 10-79
 - write card 10-79
 - write image 10-79
- register 11-13, 11-15
- register read/write 9-10, 11-40
- register set
 - summary 11-12
- reread
 - get data 10-41
 - set data 10-41
- resample
 - get data 10-15 - 10-16

- reset
 - control register 12-8
 - dsp 10-21
 - executing 11-25
 - lbus 10-22
 - module 10-23
 - zoom control register 12-39
- restore state file 10-24
- ROSCillator 11-52 - 11-54
- *RST 11-25
- running tests 2-7

S

- sample clock
 - get frequency (la) 10-64
 - in multiple mainframes 9-5
 - set frequency (la) 10-64
- sampling ADC 7-2
- save state file 10-24
- scale
 - get logical address (la) 10-19
- SCALed mode 11-34
- scaling factors 11-33
- SCPI
 - background 11-2
 - commands 11-4
 - register set summary 11-17
 - syntax 11-4 - 11-6
- SCPI installing driver 1-8
- self-test 11-29
- SEND PORT control register 12-21
- [SENSe:]CORRection:INPut:OFFSet 11-47
- [SENSe:]CORRection:TRIGger:PHASe? 11-48
- [SENSe:]FILTer[:BPASs]:MODE 11-49
- [SENSe:]FREQuency:CENTer 11-50
- [SENSe:]FREQuency:SPAN 11-51
- [SENSe:]ROSCillator:DSP:SOURce 11-52
- [SENSe:]ROSCillator:MASTer 11-53
- [SENSe:]ROSCillator:SOURce 11-54
- [SENSe:]SWEep:MODE 11-56
- [SENSe:]SWEep:OFFSet:POINts 11-57
- [SENSe:]SWEep:POINts 11-58
- [SENSe:]VOLTage:[DC:]RANGE:AUTO 11-60
- [SENSe:]VOLTage:[DC:]RANGE[:UPPer] 11-59
- serial poll 11-11
- service 11-10 - 11-11

service request 11-9 - 11-11
 Service Request enable register
 setting 11-26
 set try recover 10-14
 shipping 1-10
 SINGLE 11-49
 size, data 11-33, 11-35
 SLOPe 11-73
 trigger setup register 12-24
 software; version 10
 SOURce 11-52, 11-54
 SOURce (trigger) 11-74
 space character (WSP) 11-5
 span 11-51
 get span 10-65
 set zoom 10-65 - 10-66
 special syntactic elements 11-4
 specifications
 accuracy 2-11
 analog input 2-10
 clock 2-16
 dynamic range 2-14
 filtering 2-12
 general 2-19
 programming 2-18
 trigger 2-17
 *SRE 11-26
 standard event register set 11-15
 clearing 11-21
 reading 11-21
 setting 11-20
 state
 restore file 10-24
 save file 10-24
 selection 11-44
 status register 12-6
 status 11-11
 status byte register
 clearing 11-19
 reading 11-27
 register set 11-13
 status LEDs 8-2
 status register
 fields 12-5
 how to use 11-9
 model 11-7
 state 12-6
 STATus:OPERation:CONDition? 11-61
 STATus:OPERation:ENABle 11-62
 STATus:OPERation[:EVENT]? 11-63
 STATus:PRESet 11-64
 STATus:QUEStionable:CONDition?
 11-65
 STATus:QUEStionable:ENABle 11-66
 STATus:QUEStionable[:EVENT]? 11-67
 *STB? 11-27
 stop
 See ABORT
 subclass register 12-27
 SWEEp 11-56 - 11-58
 sync
 get multi 10-60
 multiple modules 11-79
 set multi 10-60
 Sync In 8-2
 Sync Out 8-2
 SYNC_VALID status register 12-6
 syntax
 conventions 11-5
 message terminators 11-5
 syntax descriptions 11-6
 CHANNELS 11-6
 CHAR 11-6
 DEF_BLOCK 11-6
 STRING 11-6
 SYSFAIL INHIBIT control register 12-8
 SYSTem (ADC clock source) 11-54
 SYSTem:ERRor? 11-68
 SYSTem:TIMEout 11-69
T
 TAG 11-36
 temp coarse register 12-36
 temp fine register 12-36
 test
 data collection 10-9
 equipment 2-2, 2-4
 fifo memory 10-9
 interrupts 10-9
 logical address 10-9
 measurement control 10-9
 performance 2-2
 register access 10-9
 running tests 2-7
 self-test 11-29
 timing setup 10-9
 trigger 10-9
 time elapsed 11-48
 TIMEout 11-69
 timeout; get,set 10-67
 timing
 C library commands 9-10

timing setup register 12-28
 TRACK ONLY timing set register 12-30
 TRAIler 11-37
 transporting 1-10
 *TRG 11-28
 TRIG_INTERNAL setup register 12-24
 trigger 11-48
 *TRG 11-28
 get bandwidth 10-44
 get delay 10-68
 get level for ADC 10-70
 get magnitude level 10-71
 get phase 10-17
 get slope 10-75
 get source 10-76
 initiating 12-23
 input 8-2
 lines 8-5
 modes 7-8
 set delay 10-68
 set level for ADC 10-70
 set magnitude level 10-71
 set mode 10-72
 set slope 10-75
 set source 10-76
 specifications 2-17
 state 11-42
 test 10-9
 waiting for TRIG bit 11-16
 trigger delay
 calculating 12-33
 setting 11-57
 trigger module 10-78
 TRIGGER OFFSET HIGH 12-25
 trigger offset low register 12-27
 trigger setup register
 initiating a trigger event 12-23
 TRIGLEVEL 12-23
 TRIGOFF 12-24
 TRIGSOURCE 12-24
 TRIGGER state
 ADC 11-71
 description 12-14
 level 11-72 - 11-73
 manual 11-70
 source 11-74
 TRIGger:LEVel:RATio 11-72
 TRIGger:LEVel[:ADC] 11-71
 TRIGger:SLOPe 11-73
 TRIGger:SOURce 11-74
 TRIGger[:IMMediate] 11-70
 Triggering
 commands 9-8
 process 9-5
 TRIGLEVEL trigger setup register 12-23
 TRIGOFF trigger setup register 12-24
 TRIGSOURCE setup register 12-24
 troubleshooting
 using HP-IB commands 3-2
 using performance tests 3-5 - 3-6
 *TST? 11-29
 TYPE 11-38
U
 UPPer 11-59
 utility bus 8-4
V
 VINStrument 11-75
 VINStrument[:CONFigure]:LBUS[:MODE] 11-75
 VINStrument[:CONFigure]:PORT 11-76
 VME (port) 11-76
 VOLTage 11-59 - 11-60
 VXI
 backplane 11-53
 backplane connections 8-4
 programming multiple mainframes 9-5
 VXI:REGister:READ? 11-40
 VXI:REGister:WRITE 11-40
W
 *WAI 11-30
 WRAP 11-39
 write
 register 10-79
 register card 10-79
 register image 10-79
 write to a register 11-40
 WSP 11-5
Z
 zoom
 control register 12-37
 filtering 7-4
 frequency shifting 12-36
 set span 10-65
 zoom programming
 frequency (example) 12-41
 frequency/phase registers 12-40
 phase (example) 12-43

Declaration of Conformity

According to ISO/IEC Guide 22 and EN 45014

Manufacturer's name: Hewlett-Packard Company
Manufacturer's address: Lake Stevens Instrument Division
8600 Soper Hill Road
Everett, Washington 98205-1298

declares, that the product

Product Name: Digitizer Module
Model Number: HP E1430A

conforms to the following specifications:

Safety: IEC 348/HD401

EMC: CISPR 11: 1990/EN55011 (1991), Group 1, Class A
IEC 801-2: 1991/EN50082-1 (1992): 4 kV CD, 8 kV AD
IEC 801-3: 1984/EN50082-1 (1992): 3 V/m (1)
IEC 801-4: 1988/EN50082-1 (1992): 1 kV

Supplementary Information:

The product herewith complies with the requirements of the Low Voltage Directive 73/23/EEC and the EMC Directive 89/336/EEC.

(1) In a 3 V/m field, some degradation of product performance occurs.

Everett, Washington - March 31, 1993

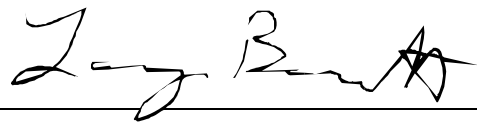

Larry Bennett, Product Services Manager

Need Assistance?

If you need assistance, contact your nearest Hewlett-Packard Sales and Service Office listed in the HP Catalog, or contact your nearest regional office listed at the back of this guide. If you are contacting Hewlett-Packard about a problem with your HP E1430A VXI ADC module, please provide the following information:

- Model number: HP E1430A
- Software version: †
- Options:
- Date the problem was first encountered:
- Circumstances in which the problem was encountered:
- Can you reproduce the problem?
- What effect does this problem have on you?

†For information on obtaining the software version see page 3-2, "To troubleshoot using HP-IB interface," or page 11-22.

About this edition

June 1995: Fourth Edition. In this edition, Chapter 3 and Chapter 5 were updated to reflect changes made in the repair procedure for the HP E1430A module. The HP E1430A VXI ADC Software Support Reference manual was updated and combined with the Operator's Guide, creating a User's Guide.

June 1994: Third Edition.

September 1993: Second Edition.

1992: First Edition.