

Errata

This manual may contain references to HP or Hewlett-Packard. Please note that Hewlett-Packard's former test and measurement, semiconductor products and chemical analysis businesses are now part of Agilent Technologies. To reduce potential confusion, the only change to product numbers and names has been in the company name prefix: where a product number/name was HP XXXX the current name/number is now Agilent XXXX. For example, model number HP8648 is now model number Agilent 8648.

Ce manuel peut contenir des références à <<HP>> ou <<Hewlett-Packard.>> Veuillez noter que les produits de test et mesure, de semi-conducteur et d'analyse chimique qui avaient fait partie de la société Hewlett-Packard sont maintenant une partie de la société Agilent Technologies. Pour réduire la confusion potentielle, le seul changement aux noms de référence a été dans le préfixe de nom de société : là où un nom de référence était HP XXXX, le nouveau nom de référence est maintenant Agilent XXXX. Par exemple, le HP 8648 s'appelle maintenant Agilent 8648.

Diese Gebrauchsanweisung kann Bezug nehmen auf die Namen HP oder Hewlett-Packard. Bitte beachten Sie, dass ehemalige Betriebsbereiche von Hewlett-Packard wie HP-Halbleiterprodukte, HP-chemische Analysen oder HP-Test- und Messwesen nun zu der Firma Agilent Technology gehören. Um Verwirrung zu vermeiden wurde lediglich bei Produktname und - Nummer der vor laufende Firmenname geändert: Produkte mit dem Namen/Nummer HP XXXX lauten nun mehr Agilent XXXX. Z.B. das Modell HP 8648 heißt nun Agilent 8648.

Questo manuale potrebbe contenere riferimenti ad HP o Hewlett-Packard. Si noti che le attività precedentemente gestite da Hewlett-Packard nel campo di Test & Misura, Semiconduttori, ed Analisi Chimica sono ora diventate parte di Agilent Technologies. Al fine di ridurre il rischio di confusione, l'unica modifica effettuata sui numeri di prodotto e sui nomi ha riguardato il prefisso con il nome dell'azienda : dove precedentemente compariva "HP XXXX" compare ora "Agilent XXXX". Ad esempio: il modello HP8648 è ora indicato come Agilent 8648.

Este manual puede hacer referencias a HP o Hewlett Packard. Las organizaciones de Prueba y Medición (Test and Measurement), Semiconductores (Semiconductor Products) y Análisis Químico (Chemical Analysis) que pertenecían a Hewlett Packard, ahora forman parte de Agilent Technologies. Para reducir una potencial confusión, el único cambio en el número de producto y nombre, es el prefijo de la compañía: Si el producto solía ser HP XXXX, ahora pasa a ser Agilent XXXX. Por ejemplo, el modelo HP8648 es ahora Agilent 8648.

这个手册里面可能含有惠普公司的资料。请注意惠普公司以前的测试, 半导体产品, 化学分析部门现在属于安捷伦公司。为了减少可能的误解, 产品号码和名字只改变最前面的公司名字。如果一个产品的号码/名字以前是HP XXXX, 现在的号码/名字是安捷伦 XXXX。例如模型号码是惠普8648。现在是模型号码安捷伦8648。

Document Part Number 08970-91012
Printed in the US April 1998



Agilent Technologies

マニュアル・チェンジ

変更

本文中の「HP (YHP)」、または「(横河)ヒューレット・パッカー株式会社」という語句を、「Agilent」、または「アジレント・テクノロジー株式会社」と変更してください。

ヒューレット・パッカー社の電子計測、半導体製品、化学分析ビジネス部門は分離独立し、アジレント・テクノロジー社となりました。

社名変更に伴うお客様の混乱を避けるため、製品番号の接頭部のみ変更しております。

(例: 旧製品名 HP 4294A は、現在 Agilent 4294A として販売いたしております。)

HP 8970B Noise Figure Meter

Operating Manual



© Copyright Hewlett-Packard Company
All rights reserved. Reproduction, adaptation, or translation without prior
written permission is prohibited, except as allowed under the copyright
laws.

Part No: 08970-91012

HP 8970B NOISE FIGURE METER

This manual covers operation of the Noise Figure Measurement System, including the HP 8970B, the HP 8971B, and the HP 8971C. System Local Oscillators are covered only in their operation as a part of this system.

Before operating the Noise Figure Meter, read the following information:

- **Error 19**

If error 19 is displayed during the calibration of the Noise Figure Measurement System, refer to the back of this page for troubleshooting help.

- **Recording IF Cal Data**

Refer to paragraph 2-14, "Recording IF Cal Data", in Section II of the HP 8970B Operating Manual. The IF attenuator data is needed to return the Noise Figure Meter to specified operation should a non-volatile memory failure occur (Error E-80).

- **For Those Familiar With The HP 8970B Noise Figure Meter, Please Note:**

The procedure for calibrating the IF attenuators has changed. If E-26 or E-13 should occur, refer to the "Calibrate, IF Attenuator" detailed operating instruction in Section III of the HP 8970B Operating Manual.

- **Maximum Input Power**

The maximum average power level for a CW signal at the RF INPUT connector of the HP 8970B must not exceed +20 dBm (100 mW), or +13 dBm (20 mW) for option 020. The maximum power for a pulsed signal is also +20 dBm (100 mW), or +13 dBm (20 mW) for option 020. The HP 8970B may be damaged by voltages exceeding ± 20 Vdc at the RF INPUT connector.

- **Using the HP 346A Noise Source with the HP 8970S/T, or HP 8970B Opt 020 and HP 8971B/C**

A preamplifier is required when using the HP 346A Noise Source to calibrate a system. Typically, a preamplifier with > 15 dB of gain and < 6 dB noise figure will work. Without a preamplifier, error E-19 will result when trying to perform a YIG-tuned filter fine peak calibration (36.3 SPECIAL FUNCTION or 36.4 SPECIAL FUNCTION) and error E-27 will result when trying to calibrate the Noise Figure Meter with 36.1 SPECIAL FUNCTION active (Disable YIG Tune in Cal). This applies to the HP 346A Noise Source only.

- **Using the HP 346A Noise Source with the HP 8970A/B**

A preamplifier may be required when using the HP 346A Noise Source to calibrate the HP 8970A/B Noise Figure Meter. If error E-27 occurs after pressing the CALIBRATE key on the noise figure meter, use a preamplifier to correct the situation. Typically, a preamplifier with > 10 dB of gain and < 6 dB noise figure will work.

(cont'd on reverse side)

• **Error 19**

Error 19 is a Noise Figure Measurement System error. The Noise Figure Measurement System consists of the Noise Figure Meter, Noise Figure Test Set and the System LO. If Error 19 is displayed, use the following steps before assuming that the Noise Figure Measurement System is malfunctioning:

1. Verify that the System LO has been connected to the Noise Figure Meter (System Interface Bus) and the Noise Figure Test Set (System Interface Bus and LO INPUT) correctly and with the proper type of cable.
2. Be sure the correct Special Function 41.X has been selected for the System LO being used.
3. Verify that the power level of the system LO is at least +7 dBm. It is assumed that the cable from the System LO to the Noise Figure Test Set is the cable that was shipped with the Noise Figure Test Set. If the cable is longer, a higher power will be needed. The power level at the Noise Figure Test Set input mixer needs to be at least +7 dBm. The power level of the system LO can be changed using Special Function 42.5.
4. Be sure at 2050MHz the System LO's AM noise is below -156 dBm/Hz and that spurs are below -45 dBm in the 10 to 2100 MHz (2400 MHz for opt 020) range and -15 dBm in the 2.1 to 18 GHz (2.4 for opt 020) range. Having AM noise and spurs outside these limits could cause a problem when calibrating.
5. When the HP 8673B/D is the System LO, be sure that the K-band amplifier is disabled for frequencies above 16 GHz. Disabling the K-band amplifier is described in the Noise Figure Meter Operating Manual, Programs Available to Control The System LO Detailed Operating Instructions.
6. Verify that the HP 346A noise source is not being used during the calibration of the Noise Figure Measurement System. The HP 346A does not have enough ENR to be used for a calibration. However, the HP 346A can be used when making a measurement.
7. Verify that FM and television signals, that fall within the input range of the Noise Figure Meter, are not leaking into the Noise Figure Measurement System and causing a problem. A spectrum analyzer can be used to look for spurs at the 20 MHz IF OUT. If spurs are found, the device under test may need shielding.
8. Be sure that the following special functions have been enabled:
 - Special Function 45.1, Enable the Noise Figure Test Set in all Modes.
 - Special Function 46.0, Enable the System LO commands.
 - Special Function 48.0, Enable the Noise Figure Meter as the system controller.
9. Be sure if a preamplifier is being used, that the calibration takes place within the passband of the preamplifier.
10. If the preceding steps didn't help, try using Special Function 0.9 to set the Noise Figure Meter to the factory preset condition. Then try Calibrating again.
11. If a problem still exists after using Special Function 0.9, refer to the Operator's Checks in the Noise Figure Meter Operating Manual to determine the instrument that is malfunctioning.

Special Considerations when using a bias tee with the HP 8970B Option 020 Noise Figure Meter

There is a possibility that the input section of the HP 8970B Option 020 Noise Figure Meter could be damaged during the measurement setup conditions of certain devices such as Low Noise Blocks (LNB's).

Typically, these devices are biased through their RF port using a bias tee. Due to the reactive components, contained within the bias tee, large transient voltages may be generated when either:

- i. The DC supply to the Device Under Test (DUT) is suddenly switched on or off.

Or:

- ii. The DC supply is interrupted when the DUT is connected to, or disconnected from, the bias tee.

Hewlett-Packard have investigated this measurement application and have some recommendations to reduce any risk of damage.

If your instrument serial prefix is less than **3811**, then consider recommendations **1** and **2**. Recommendation **1** provides adequate protection; for the most robust solution, combine both recommendations.

If your instrument serial prefix is **3811** or greater, input protection circuitry has been added to the product; however, recommendation **1** should be considered good practice.

1. Ensure that the HP 8970B Noise Figure Meter is in low sensitivity mode before the DUT power is switched off, and remains so until after the DUT power is switched back on. This mode switches 30 dB of attenuation into the input path, protecting the input circuitry. The HP 8970B Noise Figure Meter is put into low sensitivity mode by selecting **60.6 Special** and returned to auto-ranging mode by selecting **60.0 special**. If the unit is under remote program control, low sensitivity is selected by command "R6" and auto-ranging mode by "R0".

Ensure the DC supply to the bias tee is switched off before the DUT is disconnected, and is not switched on until the next DUT is connected.

2. Use a microwave limiter (**HP part number 5086-7746**) to reduce the amplitude of any voltage transients presented to the input section. This can be purchased from your nearest Hewlett-Packard Sales Office. This device has been thoroughly evaluated and causes no degradation in instrument specifications.

8970B Recommended Local Oscillators

The following is a list of recommended Local Oscillators (LO) for the 8970B along with the language settings and special functions used to invoke the corresponding System LO programs in the 8970B.

Model Number	Language Mode	Special Function
83751A/52A	8350	41.0
8671B/72B	N/A	41.2
8673B/C/E/G	N/A	41.3
8340B/41B	N/A	41.4
83620A/22A/30A/40A/50A	Analyzer	41.4
83711A/12A/31A/32A	N/A	41.5*
83711B/12B/31B/32B	SCPI	41.5*
83711B/12B/31B/32B	8673	41.3

*The Custom Local Oscillator Program (Special Function 41.5) is meant to be used with local oscillators that require anywhere from two (2) to twenty-two (22) ASCII characters to define the command sequence that sets the output frequency or output power. Special Function 41.5 default data will control the: 83711/12/31/32 (SCPI MODE), no custom programming is needed for these units.

For detailed programming information see Section III "Programming the System LO (DOI cont'd)".

Noise Declaration

LpA < 70dB

am Arbeitsplatz (operator position)
normaler Betrieb (normal position)
nach DIN 45635 pt.19 (per ISO 779)

Statement of Compliance

Electromagnetic Compatibility (EMC) Information

This product has been designed to meet the protection requirements of the European Communities Electromagnetic Compatibility (EMC) directives:

EN55011:1991 (Group1, Class A)
EN50082-1:1992
- IEC 1000-4-2 (1995) ESD
- IEC 1000-4-3 (1995) Radiated Susceptibility
- IEC 1000-4-4 (1995) EFT

In order to preserve the EMC performance of the product, any cable which becomes worn or damaged must be replaced with the same type and specification.

Safety Information

This instrument has been designed and tested in accordance with publication EN61010-1(1993)/ IEC 1010-1(1990) +A1(1992) +A2(1994) / CSA C22.2 No. 1010.1(1993) Safety Requirements for Electrical Equipment for Measurement, Control and Laboratory Use, and has been supplied in a safe condition. The instruction documentation contains information and warnings which must be followed by the user to ensure safe operation and to maintain the instrument in a safe condition.

Declaration of Conformity

according to ISO/IEC Guide 22 and EN45014

Manufacturer's Name: Hewlett-Packard Ltd.

Manufacturer's Address: Queensferry Microwave Division
South Queensferry
West Lothian, EH30 9TG
Scotland, United Kingdom

Declares that the product

Product Name: Noise Figure Meter

Model Numbers: HP 8970B

Product Options: This declaration covers all options of the above products as detailed in TCF A-5951-9852-02

Conforms with the protection requirements of European Council Directive 89/336/EEC on the approximation of the laws of the member states relating to electromagnetic compatibility.

Against EMC test specifications EN 55011:1991 (Group 1, Class A) and EN 50082-1:1992

As Detailed in: Electromagnetic Compatibility (EMC)
Technical Construction File (TCF) No. A-5951-9852-02

Assessed by: Dti Appointed Competent Body
EMC Test Centre,
GEC-Marconi Avionics Ltd.,
Maxwell Building,
Donibristle Industrial Park,
KY11 5LB
Scotland, United Kingdom

Technical Report Number:6893/2200/CBR, dated 23 September 1997

Supplementary Information:

The product conforms to the following safety standards:

EN 61010-1(1993) / IEC 1010-1(1990) +A1(1992) +A2(1994)
CSA-C22.2 No. 1010.1-93
EN 60825-1(1994) / IEC 825-1(1993)

The product herewith complies with the requirements of the Low Voltage Directive 73/23/EEC, and carries the CE-marking accordingly.

South Queensferry, Scotland

11 May 1998

R.M. Evans

Location

Date

R.M. Evans / Quality Manager

Europe Contact:
Your Local Hewlett-Packard Sales and Service Office or Hewlett-Packard GmbH, Department 2Q / Standards Europe
Herrenberger Strasse 130, D7030 Boblinger (Fax: +49-7031-143143)

Declaration of Conformity

according to ISO/IEC Guide 22 and EN45014

Manufacturer's Name: Hewlett-Packard Ltd.

Manufacturer's Address: Queensferry Microwave Division
South Queensferry
West Lothian, EH30 9TG
Scotland, United Kingdom

Declares that the product

Product Name: Noise Figure Test Set

Model Numbers: HP 8971C

Product Options: This declaration covers all options of the above products as detailed in TCF A-5951-9852-02

Conforms with the protection requirements of European Council Directive 89/336/EEC on the approximation of the laws of the member states relating to electromagnetic compatibility.

Against EMC test specifications EN 55011:1991 (Group 1, Class A) and EN 50082-1:1992

As Detailed in: Electromagnetic Compatibility (EMC)
Technical Construction File (TCF) No. A-5951-9852-02

Assessed by: Dti Appointed Competent Body
EMC Test Centre,
GEC-Marconi Avionics Ltd.,
Maxwell Building,
Donibristle Industrial Park,
KY11 5LB
Scotland, United Kingdom

Technical Report Number:6893/2200/CBR, dated 23 September 1997

Supplementary Information:

The product conforms to the following safety standards:

EN 61010-1(1993) / IEC 1010-1(1990) +A1(1992) +A2(1994)
CSA-C22.2 No. 1010.1-93
EN 60825-1(1994) / IEC 825-1(1993)

The product herewith complies with the requirements of the Low Voltage Directive 73/23/EEC, and carries the CE-marking accordingly.

South Queensferry, Scotland

11 May 1998

R.M. Evans

Location

Date

R.M. Evans / Quality Manager

Europe Contact:

Your Local Hewlett-Packard Sales and Service Office or Hewlett-Packard GmbH, Department 2Q / Standards Europe
Herrenberger Strasse 130, D7030 Boblinger (Fax: +49-7031-143143)

CONTENTS

I. GENERAL INFORMATION

Introduction	1-1
Specifications	1-1
Safety Considerations	1-1
Instruments Covered by Manual	1-1
Manual Updates	1-1
Description	1-2
Noise Figure Meter	1-2
HP 8970S/T/U Noise Figure Measurement System	1-4
Mechanical Options	1-4
Front Handle Kit (Option 907)	1-4
Rack Flange Kit (Option 908)	1-4
Rack Flange and Front Handle Combination Kit (Option 909)	1-4
Hewlett-Packard Interface Bus (HP-IB)	1-5
Compatibility	1-5
Selecting the HP-IB Address	1-5
System Interface Bus (SIB)	1-5
Compatibility	1-5
Selecting the SIB Address	1-5
Accessories Supplied	1-5
Equipment Required But Not Supplied	1-5
Electrical Equipment Available	1-5
HP-IB Controllers	1-5
External Mixers and System Local Oscillators	1-5
Waveguide/Coax Adapters	1-6
Front-to-Rear-Panel Connector Retrofit Kit	1-6
Mechanical Equipment Available	1-6
Chassis Slide Mount Kit	1-6
Chassis Tilt Slide Mount Kit	1-6
Recommended Test Equipment	1-6

II. INSTALLATION

Introduction	2-1
Initial Inspection	2-1
Preparation For Use	2-1
Power Requirements	2-1
Line Voltage and Fuse Selection	2-1
Power Cables	2-1
Address Selection - HP-IB	2-2
Interconnections	2-4

INSTALLATION (cont'd)

HP 8970S/T/U Noise Figure Measurement System	2-4
Mating Connectors	2-4
Operating Environment	2-4
Bench Operation	2-4
Rack Mounting	2-4
Recording IF Attenuator Values	2-6
Storage and Shipment	2-6
Environment	2-6
Packaging	2-6

III. OPERATION

Introduction	3-1
Operating Characteristics	3-1
Local Operation	3-1
Operator's Checks	3-2
Operator's Maintenance	3-2
General Operating Instructions	3-2
Turn-On	3-2
Keystroke Sequences	3-3
Operator's Checks	3-15
Basic Functional Checks	3-15
HP-IB Functional Checks	3-21
Noise Figure Measurement System Check	3-28
Remote Operation	3-33
HP-IB Compatibility	3-33
Remote Mode	3-33
Local Mode	3-33
Addressing	3-33
Data Messages	3-34
Receiving the Data Message	3-34
Sending the Data Message	3-37
Receiving the Clear Message	3-38
Receiving the Trigger Message	3-40
Receiving the Remote Message	3-40
Receiving the Local Message	3-40
Receiving the Local Lockout Message	3-41
Receiving the Clear Lockout/Set Local Message	3-41
Receiving the Pass Control Message	3-41
Sending the Require Service Message	3-41
Enabling the Service Request Condition	3-41
Sending the Status Byte Message	3-42
Clearing the Status Byte	3-43
Sending the Status Bit Message	3-44
Receiving the Abort Message	3-44
HP-IB Syntax and Characteristics Summary	3-45
Remote HP-IB Operation	3-46.1

Detailed Operating Instructions (DOI)

Calibrate	3-59
Calibration, Frequency	3-65
Calibration, IF Attenuators	3-67
Calibration, Input Gain Selection	3-69
Controller Capability of the Noise Figure Meter	3-71
Data Output to Oscilloscopes, Recorders and Plotters	3-73
Display Control	3-81
Display Resolution	3-83
Display Units Selection	3-85
ENR Table Entry	3-87

Error Messages (DOI cont'd)

Error Messages and Recovery	3-93
Fixed Frequency Increment	3-105
Fixed Frequency Tuning	3-108
Fixed IF or LO Frequency Selection	3-110
HP-IB and System Interface Bus (SIB) Addresses	3-113
IF Attenuation Selection	3-117
Loss Compensation	3-119
Manual Measurement Functions	3-121

Measurement Modes (DOI cont'd)

Measurement Modes	3-125
Measurement Mode 1.0	3-132
Measurement Mode 1.1	3-135
Measurement Mode 1.2	3-140
Measurement Mode 1.3	3-145
Measurement Mode 1.4	3-150
Measurement Mode 1.5	3-155
Measurement Mode 1.6	3-160
Measurement Mode 1.7	3-168
Measurement Mode 1.8	3-176
Measurement Mode 1.9	3-183
Noise Figure Test Set YIG Filter Calibration	3-190
Noise Figure (Uncorrected) and Noise Figure and Gain (Corrected)	3-198
Power Measurements	3-200
Preset Conditions and Power-Up Sequence	3-205
Programming the System LO	3-211.1
Programs Available to Control the System LO	3-219
RF Attenuation Selection	3-222
Sequence	3-224
Sideband Selection	3-226
Smoothing (Averaging)	3-230
Special Function Catalog	3-233
Special Functions	3-235

Special Functions Summary (DOI cont'd)

Spot ENR, T_{hot} , T_{cold} and ENR Table Selection	3-254
Store and Recall	3-257
Sweep	3-258
System Interface Bus Control	3-262
Temperature Units Selection	3-271
Trigger Selection	3-273

IV. PERFORMANCE TESTS

Introduction	4-1
Equipment Required	4-1
Test Record	4-1
Calibration Cycle	4-1
Tuning Accuracy Performance Test	4-2
Input SWR Performance Test	4-4
Noise Figure Range and Accuracy Performance Test	4-6
Gain Measurement Uncertainty Performance Test	4-10
Instrument Noise Figure Performance Test	4-19

HP 8971B/C Performance Tests

Introduction	4-29
Equipment Required	4-29
Performance Test Record	4-29
Calibration Cycle	4-29
Performance Test Procedures	4-29
Input SWR Performance Tests	4-30
Input SWR Performance Test	4-35
Noise Figure Test	4-40
Image and Third Harmonic Rejection Test	4-49
Noise Figure and Gain Test (Includes Repeatability	4-60

ILLUSTRATIONS

1-1. HP 8970B Accessories Supplied, and Options 907, 908, and 909	1-2
1-2. HP 8971B/C Accessories Supplied and Option	1-3
2-1. Line Voltage and Fuse Selection	2-2
2-2. Power Cable and Mains Plug Part Numbers	2-2
2-3. Hewlett-Packard Interface Bus and System Interface Bus Connections	2-3
2-4. Noise Figure Measurement System Interconnections	2-6
3-1. Front Panel Features	3-4
3-2. Display and Remote Features	3-8
3-3. GAIN MAX, GAIN MIN, NOISE MAX and NOISE MIN Features	3-9
3-4. LINE Switch, PRESET and SOURCE Features	3-10
3-5. SWEEP and FIXED FREQ Features	3-11
3-6. DATA and SPECIAL FUNCTION Features	3-12
3-7. MEASUREMENT and INPUT Features	3-13
3-8. Rear Panel Features	3-14
3-9. HP 8971B/C Front Panel Features	3-14.1
3-10. HP 8971B/C Rear Panel Features	3-14.2
3-11. Basic Functional Checks Setup	3-15
3-12. Test Pattern on Oscilloscope	3-16
3-13. Noise Figure Measurement System Check Setup	3-28
3-14. Example Flow Chart for Driving the Noise Figure Meter Using the Require Service Message (SRQ)	3-43
3-15. Test Pattern on Oscilloscope	3-75
3-16. Swept Measurement on Oscilloscope	3-76
3-17. Swept Measurement on Scalar Analyzer	3-78
3-18. Noise Figure Meter Measurement Passband	3-130
3-19. Measurement Mode 1.0 Calibration Setup	3-133
3-20. Mode 1.0 Measurement Setup	3-133
3-21. Measurement Mode 1.1 Calibration Setup	3-137
3-22. Measurement Mode 1.1 Setup	3-137
3-23. Measurement Mode 1.2 Calibration Setup	3-142
3-24. Measurement Mode 1.2 Setup	3-143
3-25. Measurement Mode 1.3 Calibration Setup	3-147
3-26. Measurement Mode 1.3 Setup	3-147
3-27. Measurement Mode 1.4 Calibration Setup	3-152
3-28. Measurement Mode 1.4 Setup	3-152
3-29. Measurement Mode 1.5 Calibration Setup	3-158
3-30. Measurement Mode 1.5 Setup	3-158

3-31. Measurement Mode 1.6 Calibration Setup	3-164
3-32. Measurement Mode 1.6 Setup	3-164
3-33. Measurement Mode 1.7 Calibration Setup	3-172
3-34. Measurement Mode 1.7 Setup	3-173
3-35. Measurement Mode 1.8 Calibration Setup	3-180
3-36. Measurement Mode 1.8 Setup	3-181
3-37. Measurement Mode 1.9 Calibration Setup	3-187
3-38. Measurement Mode 1.9 Setup	3-187
3-39. YIG Filter Calibration Setup	3-193
3-40. YIG Filter Calibration Setup	3-195
3-41. Special Functions	3-233
4-1. Input SWR Test Setup	4-4
4-2. Noise Figure Instrumentation Accuracy Test Setup	4-7
4-3. IF Attenuator Calibration Setup	4-11
4-4. Gain Measurement Uncertainty Test Setup	4-16
4-6. SWR Test Setup	4-31
4-7. Fine Peak YIG Test Setup	4-36
4-8. SWR Test Setup	4-37
4-9. Noise Figure Calibration Test Setup	4-41
4-10. Noise Figure Test Setup	4-42
4-11. Image and Odd Harmonic Rejection Test Setup	4-50
4-12. Gain Test Reference Setup SSB1	4-61
4-13. Gain Test Setup SSB1	4-63
4-14. Noise Figure and Gain Calibration Test Setup SSB2/SSB3	4-64
4-15. Noise Figure and Gain Test Setup SSB2/SSB3	4-68

TABLES

1-1. Noise Figure Meter Specifications	1-7
1-2. Noise Figure Meter Supplemental Characteristics	1-9
1-3. Noise Figure Measurement System Specifications	1-10
1-4. Noise Figure Measurement System Supplemental Characteristics	1-11
1-5. HP 8971C Specifications	1-12
1-6. HP 8971C Supplemental Characteristics	1-13
1-7. Noise Figure System Specifications (HP 8970B with HP 8971C Std. and Opt. 001	1-14
1-8. Supplemental Characteristics (HP 8970B with HP 8971C and Opt. 001)	1-15
1-9. Noise Figure System Specifications (HP 8970B with HP 8971C Option 002)	1-16
1-10. Supplemental Characteristics	1-17
1.11. HP 8970B or HP 8970B Opt. 020 Recommended Test Equipment	1-18
1.12 HP 8970B or HP 8970B Opt. 020 Recommended Test Equipment	1-19
1-13 HP 8971C Recommended Test Equipment	1-20
1-14 HP 8971B Recommended Test Equipment	1-21
2-1. Noise Figure Meter Factory Set Addresses	2-4
2-2. ASCII Address Codes to Decimal Equivalents	2-4
3-1. Operating Characteristics	3-3
3-2. Detailed Operating Instructions Table of Contents (Functional)	3-6
3-3. Message Reference Table	3-35
3-4. Functions Not Programmable Via HP-IB	3-36
3-5. HP-IB Data Output Summary	3-38
3-6. Response to a Clear Message (or Pressing PRESET)	3-39
3-7. Service Request Enabled Conditions Summary	3-42
3-7.1 Programming Quick Reference Guide	3-46.2
3-7.2 HP-IB Message Reference Table	3-46.8
3-7.3 HP-IB Program Codes	3-46.10
3-8. Noise Figure Meter HP-IB Code to Parameter Summary	3-47
3-9. Special Function to HP-IB Code	3-51
3-10. Front Panel Keys to HP-IB Code Summary	3-57
3-11. Commonly Used Code Conversions	3-58
3-12. Front Panel Summary	3-206

3-13. Special Function 0.9 and Preset Default Values for Special Functions	3-207
3-14. Special Function Summary	3-239
4-1. IF Attenuator Values	4-14
4-2. Performance Test Record	4-23
4-3. HP 8971B/C SWR Test Results	4-34
4-4. HP 8971B/C SWR Test Results	4-39
4-5. HP 8971C SSB1 Noise Figure Test Results	4-43
4-6. HP 8971C SSB2 Noise Figure Test Results	4-45
4-7. HP 8971C SSB3 Noise Figure Test Results	4-48
4-8. Power Reference, Image and Harmonic	4-52
4-9. HP 8971B Image and Third Harmonic Rejection	4-53
4-10. Performance Test Record	4-54
4-11. HP 8971B SSB1 Noise Figure and Gain	4-62
4-12. HP 8971B SSB1 Repeatability	4-63
4-13. HP 8971B SSB2 Noise Figure and Gain	4-66
4-14. HP 8971B SSB2 Repeatability	4-67
4-15. HP 8971B SSB3 Noise Figure and Gain	4-71
4-16. HP 8971B SSB3 Repeatability (YIG Tuning)	4-74
4-17. HP 8971B SSB3 Reapeatability (Microwave Relays)	4-75
4-18. HP 8971B DSB Repeatability (Microwave Relays)	4-78

General Safety Information

The following general safety precautions must be observed during all phases of operation, service, and repair of this instrument. Failure to comply with these precautions or with specific warnings elsewhere in this manual violates safety standards of design, manufacture, and intended use of the instrument. Hewlett-Packard Company assumes no liability for the customer's failure to comply with these requirements.

WARNING

This is a Safety Class I instrument (provided with a protective earthing ground, incorporated in the powercord). The mains plug shall only be inserted in a socket outlet provided with a protective earth contact. Any interruption of the protective conductor inside or outside of the instrument is likely to make the instrument dangerous. Intentional interruption is prohibited.

DO NOT operate the product in an explosive atmosphere or in the presence of flammable gasses or fumes.

DO NOT use repaired fuses or short-circuited fuseholders: For continued protection against fire, replace the line fuse(s) only with fuse(s) of the same voltage and current rating and type.

DO NOT perform procedures involving cover or shield removal unless you are qualified to do so: Operating personnel must not remove equipment covers or shields. Procedures involving the removal of covers and shields are for use by service-trained personnel only.









DO NOT service or adjust alone: Under certain conditions, dangerous voltages may exist even with the equipment switched off. To avoid dangerous electrical shock, service personnel must not attempt internal service or adjustment unless another person, capable of rendering first aid and resuscitation, is present.

DO NOT operate damaged equipment: Whenever it is possible that the safety protection features built into this product have been impaired, either through physical damage, excessive moisture, or any other reason, REMOVE POWER and do not use the product until safe operation can be verified by service-trained personnel. If necessary, return the product to a Hewlett-Packard Sales and Service Office for service and repair to ensure the safety features are maintained.

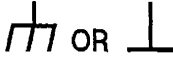
DO NOT substitute parts or modify equipment: Because of the danger of introducing additional hazards, do not install substitute parts or perform any unauthorized modification to the product. Return the product to a Hewlett-Packard Sales and Service Office for service and repair to ensure the safety features are maintained.

Safety Symbols

The following symbols on the instrument and in the manual indicate precautions which must be taken to maintain safe operation of the instrument.

Safety Symbols	
	The Instruction Documentation Symbol. The product is marked with this symbol when it is necessary for the user to refer to the instructions in the supplied documentation.
	Indicates the field wiring terminal that must be connected to earth ground before operating the equipment - protects against electrical shock in case of fault.
 OR 	Frame or chassis ground terminal - typically connects to the equipment's metal frame.
	Alternating current (AC)
	Direct current (DC)
	Indicates hazardous voltages
WARNING	Warning denotes a hazard. It calls attention to a procedure, which if not correctly performed or adhered to could result in injury or loss of life. Do not proceed beyond a warning note until the indicated conditions are fully understood and met.
CAUTION	Caution denotes a hazard. It calls attention to a procedure, which if not correctly performed or adhered to could result in damage to or destruction of the instrument. Do not proceed beyond a caution note until the indicated conditions are fully understood and met.
	The CE mark shows that the product complies with all relevant European Legal Directives.
ISM 1-A	This is a symbol of an Industrial, Scientific, and Medical Group 1 Class A product.
	The CSA mark is a registered trademark of the Canadian Standards Association, and indicates compliance to the standards layed out by them.

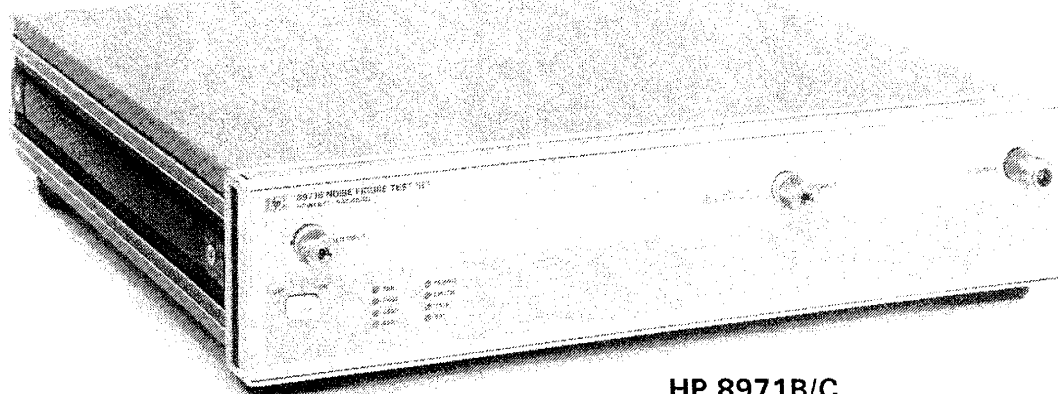

HP 8971B/C

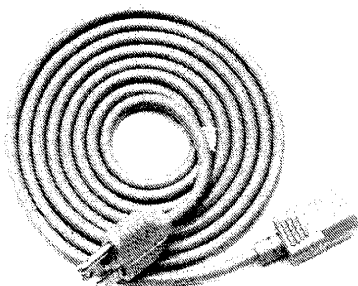

LINE POWER CABLE

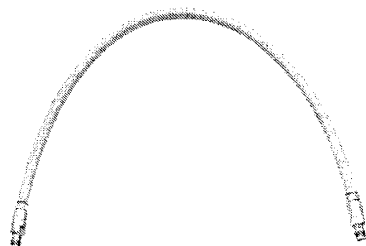

LO INPUT CABLE

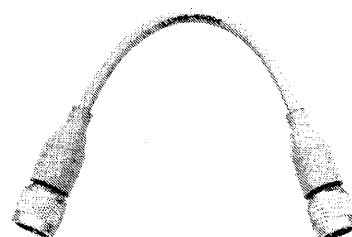

IF OUTPUT CABLE

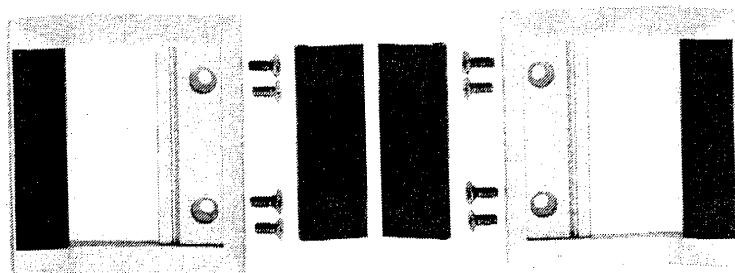

OPTION 907
FRONT HANDLE KIT

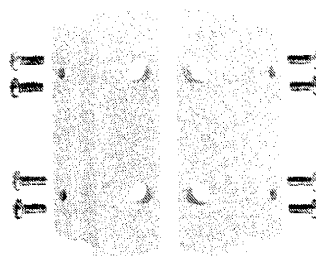

OPTION 908
RACK FLANGE KIT

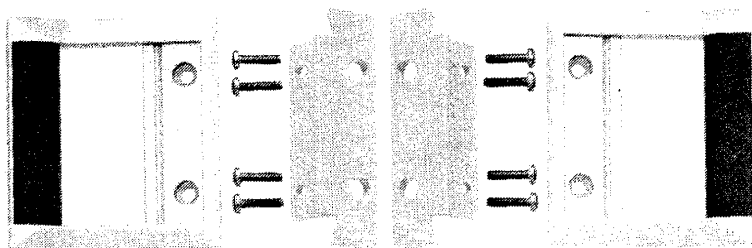

OPTION 909
RACK FLANGE KIT AND FRONT HANDLE COMBINATION KIT

Figure 1-2. HP 8971B/C Accessories Supplied and Option

or any part of that range. To measure the noise figure of devices with output frequencies greater than 1600 MHz (2047 MHz, opt 020), an external mixer and local oscillator can be used to convert the frequency to the 10 to 1600 MHz (2047 MHz, opt 020) range. Measured noise can be displayed as noise figure, equivalent input noise temperature or Y-Factor. Gain is displayed in dB.

Once calibrated, a single keystroke of the Noise Figure Meter can automatically remove the measurement system noise and gain contribution (called second stage correction). The Noise Figure Meter then displays only the noise figure and gain of the device under test (DUT).

Five Excess Noise Ratio (ENR) tables (four stored tables and one working table) can be entered into the Noise Figure Meter. Each table can have up to 35 entries. The Noise Figure Meter uses this data to correct for ENR versus frequency variations. For measurements made between calibration points, ENR data is interpolated. When the instrument is turned off, the ENR tables are stored in nonvolatile memory.

X- and Y-Axis outputs on the rear panel allow for noise figure and gain versus frequency to be displayed on a storage or nonstorage oscilloscope, or output to a recorder. On an oscilloscope, gain can be displayed at a lower intensity than noise figure, to distinguish between the two traces. The Z-Axis output blanks an oscilloscope or lifts a recorder pen. A storage oscilloscope can also be used, but the differences in trace intensity are obscured.

Most functions can be remotely programmed via the Hewlett-Packard Interface Bus (HP-IB) and all measurement data is available to the HP-IB. The Noise Figure Meter has a second bus, the System Interface Bus (SIB). The System Interface Bus is a private bus used by the Noise Figure Meter to control certain instruments in the Noise Figure Measurement System. Instruments controlled by the SIB are the Noise Figure Test Set, the System Local Oscillator and a plotter.

1-8. Noise Figure Measurement System

The HP Noise Figure Measurement System extends the frequency range of the Noise Figure Meter from 1600 MHz (2047 MHz, opt 020) to 18000/26500 MHz. The HP Noise Figure Measurement System consists of the Noise Figure Meter, the HP 8971B/C Noise Figure Test Set and a System Local Oscillator.

All the features described about the Noise Figure Meter apply to the Noise Figure Measurement System, with the following changes:

- The Noise Figure Measurement System can be tuned between 10 and 18000/26500 MHz.
- The noise figure of devices with output frequencies greater than 18000/26500 MHz can be measured with the addition of an external mixer and a second, user-controlled, local oscillator (double-down-conversion).
- Measurements using interpolated calibration data are not allowed for measurement modes 1.5 through 1.9 unless a special function has been selected.

For Simplicity, the Noise Figure Measurement System can be thought of as one instrument. The Noise Figure Meter's System Interface Bus is used to control the Noise Figure Test Set and the System Local Oscillator.

1-9. MECHANICAL OPTIONS

The following options may have been ordered and received with the Noise Figure Meter. If they were not ordered with the original shipment, they can be ordered from the nearest Hewlett-Packard office using the part number included in each of the following paragraphs.

1-10. Front Handle Kit (Option 907)

Ease of handling is increased with the front panel handles. Order HP part number 5062-3989 for the HP 8970B or 5062-3988 for the HP 8971B/C.

1-11. Rack Flange Kit (Option 908)

The Noise Figure Meter can be solidly mounted to the instrument rack using the flange kit. Order HP part number 5062-3977 for the 8970B or 5062-3974 for the HP 8971B/C.

1-12. Rack Flange and Front Handle Combination Kit (Option 909)

This is not a front handle kit and a rack flange kit package together; it is composed of a unique part which combines both functions. Order HP part number 5062-3983 for the 8970B or 5062-3975 for the HP 8971B/C.

1-13. HEWLETT-PACKARD INTERFACE BUS**1-14. Compatibility**

The Noise Figure Meter is compatible with HP-IB to the extent indicated by the following code: SH1, AH1, T5, TE0, L4, LE0, SR1, RL1, PP0, DC1, DT1, C0, and E1. The Noise Figure Meter interfaces with the bus via open collector TTL circuitry. An explanation of the compatibility code can be found in IEEE Standard 488 (1978), "IEEE Standard Digital Interface for Programmable Instrumentation" or the identical ANSI Standard MC1.1. For more detailed information relating to programmable control of the Noise Figure Meter, refer to Remote Operation, Hewlett-Packard Interface Bus in Section III of this manual.

1-15. Selecting the HP-IB Address

The Noise Figure Meter can use two HP-IB addresses. One is the address of the Noise Figure Meter. The second is the HP-IB address of the Noise Figure Meter when it is in Pass Through Mode. (Pass Through Mode allows commands to be passed through the Noise Figure Meter from a computer on the HP-IB to an instrument on the SIB.) Refer to the HP-IB and System Interface Bus (SIB) Addresses Detailed Operating Instruction, in Section III, for additional information.

1-16. SYSTEM INTERFACE BUS (SIB)

The System Interface Bus is a private bus used by the Noise Figure Meter to control the Noise Figure Test Set, the System Local Oscillator and a plotter.

1-17. Compatibility

The System Interface Bus is compatible with IEEE Standard 488 (1978) to the extent indicated by the following codes: SH1, AH1, T6, TE0, L4, LE0, RL1, PP0, DC1, DT0, C1, C2, C3, C4, C7 and E1. The Noise Figure Meter interfaces with the bus via open collector TTL circuitry. An explanation of the compatibility code can be found in IEEE Standard 488 (1978), "IEEE Standard Digital Interface for Programmable Instrumentation" or the identical ANSI Standard MC1.1.

1-18. Selecting the SIB Address

The Noise Figure Meter uses SIB addresses for the following:

- System Local Oscillator
- Noise Figure Test Set
- Plotter
- System Interface Bus
- Pass Control
- Pass Through Device on the SIB

For more information on selecting the SIB addresses, refer to the HP-IB and System Interface Bus (SIB) Addresses Detailed Operating Instruction, in Section III.

1-19. ACCESSORIES SUPPLIED

The accessories supplied with the Noise Figure Meter are shown in Figure 1-1 and Figure 1-2.

a. The line power may be supplied in several configurations, depending on the destination of the original shipment. Refer to paragraph Power Cables in Section II of this manual.

b. Two fuses, one for 100/200 Vac operation and one for 220/240 Vac operation are supplied. One fuse is factory installed according to the voltage available in the country of original destination. Refer to paragraph line " Voltage and Fuse Selection" in Chapter 2 of this manual.

c. The 8971B/C LO Input Cable, SMA female to SMA female, is HP part number 08971-60126.

60127

d. The 8971B/C IF Output Cable, Type N male to Type N male, is HP part number 11793-60006.

e. The 8971B/C Coaxial Adapter, SMA male to Type N male, is HP part number 1250-1636.

f. The 8971B/C has two HP 10833D 0.5 meter long HP-IB cables that are supplied.

1-20. EQUIPMENT REQUIRED BUT NOT SUPPLIED

A noise source such as HP Model 346B (346A or 346C), must be used with the Noise Figure Meter. The Noise Figure Meter supplies +28.0V pulses to drive the noise source on and off.

1-21. ELECTRICAL EQUIPMENT AVAILABLE**1-22. HP-IB Controllers**

The Noise Figure Meter has an HP-IB interface and can be used with any HP-IB compatible computing controller or computer for automatic systems applications.

1-23. System Local Oscillators

The System Local Oscillator is part of the Noise Figure Measurement System. Suitable local oscillators include the HP 8671B, HP 8672A or HP 8673B, C, D, E, G Synthesized Signal Generators and the HP 8340B, HP 8341B or the HP 8360 Synthesized Sweeper. The upper frequency limit of the Noise Figure Measurement System can be limited by the local oscillator.

The HP 8673B and G Option 008 and the HP 8673D use an amplifier to increase the output power above 16 GHz. The amplifier used in instruments prior to serial number prefix 2930A produces excessive broadband noise which can degrade the noise figure of the Noise Figure Measurement System. IF one of these signal generators is being used as the system local oscillator and the output signal is greater than or equal to 16 GHz, the amplifier must be removed from the output signal path. For more information, see manual section titled "Programming the System LO".

1-24. Waveguide/Coax Adapters

The HP 346B/C Noise Source combined with the HP X281C or P281C Waveguide/Coax Adapter makes a very accurate, calibrated waveguide noise source.

1-25. MECHANICAL EQUIPMENT AVAILABLE

1-26. Chassis Slide Mount Kit

This kit is extremely useful when the Noise Figure Meter is rack mounted. Access to internal circuits and components or the rear panel is possible without removing the instrument from the rack. Order

HP part number 1494-0060 for 430 mm (17 inch) fixed sides and part number 1494-0061 for the correct adapters for non-HP rack enclosures.

1-27. Chassis Tilt Slide Mount Kit

This kit is the same as the Chassis Slide Mount Kit above except that it also allows the tilting of the instrument up or down 90 degrees. Order HP part number 1494-0062 for 430 mm (17 inch) tilting slides and part number 1494-0061 for the correct adapters for non-HP rack enclosures.

1-28. RECOMMENDED TEST EQUIPMENT

Tables 1-11 thru 1-15 lists the test equipment recommended for use in testing, adjusting, and servicing the Noise Figure Meter. The "Critical Specification" column describes the essential requirements for each piece of test equipment. Other equipment can be substituted, if it meets or exceeds these critical specifications.

The "Recommended Model" column may suggest more than one model. The first model shown is usually the least expensive, single-purpose model. Alternate models are suggested for additional features that would make them a better choice in some applications.

Table 1- 1 HP 8970B Noise Figure Meter Specifications (1 of 2)

Characteristics	Performance Limits	Conditions
NOISE FIGURE MEASUREMENT Range Resolution Instrumentation Uncertainty	0 to 30 dB 0.01 dB ¹ ± 0.1 dB	For a noise source in a 0 to 55°C environment with an ENR of 14 to 16 dB
GAIN MEASUREMENT Range Resolution Instrument Uncertainty	-20 to > + 40 dB 0.01 dB ¹ 0.1 dB ² ±0.15 dB	For total noise figures ≤30 dB Gain ≥ -9.99 dB Gain < -9.99 dB
INPUT Frequency Range Frequency Resolution Tuning Accuracy Noise Figure Input SWR (Reflection Coefficient) STD Option 020 ³ Maximum Operating Input Power Maximum Net External Gain Reducing System Noise Figure with Pre-amplification	Tunable from 10 to 1600 MHz (2047 MHz, opt 020) 1 MHz ±(1 MHz + 1% of frequency), ±6 MHz maximum <7 dB +0.003 dB/MHz (+0.002 dB, opt 020) <1.7(0.26) 10 to 1600 MHz <1.8(0.286) 10 to 1600 MHz <2.0(0.33) >1600 to 2047 MHz -10 dBm (wideband) >65 dB <1.8 dB + noise figure of the external system	From +10 to +40°C For input power levels below -60 dBm 50Ω reference impedance Between noise source and HP 8970B RF Input Low noise external pre-amplification with net gain >20 dB
ELECTROMAGNETIC COMPATABILITY Designed to meet MIL STD 461B-1980 Conducted and Radiated Emissions Conducted and Radiated Immunity		MIL STD 461B-1980 using method CE03 MIL STD 461B-1980 using method CS01, CS02 and RS03
¹ Resolution over the Hewlett-Packard Interface Bus is 0.001 dB ² Resolution over the Hewlett-Packard Interface Bus is 0.01 dB ³ For serial prefixes below 3811: <1.7(0.26) 10 to 1600 MHz		

Table 1- 1. HP 8970B Noise Figure Meter Specifications (2 of 2)

Characteristics	Performance Limits	Conditions
<p>Meets the requirements of the European Union EMC Directive 89/336/EMC plus amendments and is CE marked accordingly.</p> <p>Conducted and Radiated Emissions</p> <p>Conducted and Radiated Immunity</p>	<p>EN 55011, 1991 Group 1, Class A</p> <p>EN 50082-1, 1992</p>	<p>Electrostatic Discharge immunity according to IEC 1000-4-2, 1995 at 8 kV air discharge and 4 kV contact discharge.</p> <p>Radiated Immunity according to IEC 1000-4-3, 1995 at 3 V/m from 27 to 500 MHz.</p> <p>Electrical Fast Transients - bursts according to IEC 1000-4-4, 1995 at 1.0 kV mains and 0.5 kV ports.</p>
<p>GENERAL</p> <p>Noise Source Drive</p>  <p>Power Requirements</p> <p>Line Voltage: 100, 120, 220, 230, or 240 V</p> <p>Operating Frequency Range</p> <p>Power Dissipation</p> <p>Temperature:</p> <p>Operating</p> <p>Storage</p> <p>Humidity</p> <p>Remote Operation (HP-IB)</p> <p>Dimensions:</p> <p>Height</p> <p>Width</p> <p>Depth</p> <p>Net Weight</p>	<p>28.0 ±0.1 V <1 V</p> <p>±10%</p> <p>48 - 66 Hz</p> <p>150 VA maximum</p> <p>0 to 55°C -55 to 75°C Up to 95% Relative Humidity to 40°C</p> <p>IEEE STD 488-1978 Compatibility Code: SH1, AH1, T5, TE0 L4, LE0, SR1, RL1, PP0, DC1, DT1, C0 and E1</p> <p>146 mm (5.75 in.) 425 mm (16.8 in.) 462 mm (18.2 in.) 15.5 kg (34 lbs)</p>	<p>Noise source ON at up to 60 mA peak. Noise source OFF.</p> <p>The Hewlett-Packard Interface Bus (HP-IB) is Hewlett-Packard's implementation of IEEE Std 488-1978, "Digital Interface for Programmable Instrumentation". Most functions are remotely programmable.</p> <p>Note: For ordering cabinet accessories, the module sizes are 5¹/₄H, 1 MW (Module width), and 17D.</p>

Table 1-2. HP 8970B Noise Figure Meter Supplemental Characteristics

Supplemental characteristics are intended to provide information useful in applying the instrument by giving typical, but non-warranted, performance parameters.

All parameters describe performance in automatic operation or properly set manual conditions.

Bandwidth: approximately 4 MHz.

Audible Noise Level: <5.5 bels at 1 metre.

Sensitivity: no external gain required; -100 dBm; able to measure its own noise figure.

Measurement Speed: about 6 to 9 measurements per second with minimum smoothing.

Sweep Speed at Minimum Smoothing (10 to 1600 MHz): 140 ms per frequency point.

Maximum Safe Input Level: ± 20 Vdc; +20 dBm peak (or average) at RF.

Jitter Peak-to-peak² Y-factor variation <0.15 dB At minimum smoothing
Peak-to-peak² Y-factor variation <0.02 dB With increased smoothing (smoothing factor set to 64).

Note: Jitter in noise figure is equivalent to jitter in Y factor to within 10% for ENR > 14 dB and F < 4 dB. At minimum smoothing, jitter can limit accuracy; the small jitter at high smoothing does not.

FUNCTIONAL PROPERTIES

Noise Figure Display Units: noise figure in dB or as a ratio, or uncorrected Y-Factor in dB or as a ratio, or effective input noise temperature in kelvins.

Displayed Measurement Frequency Range: 10 to 99999 MHz.

Number of Calibration Points in One Sweep: 181

System LO Control: frequency control over the System Interface Bus from 10 to 99999 MHz.

Noise Figure Display Jitter: <0.01 dB with appropriate smoothing.

Cold Noise Source Data Range: 0 to 9999K.

Hot Noise Source Data Range: stored table — ENR from -7 to +50 dB; spot frequency — from 0 to 14824K.

Storage Capacity of Hot Noise Source Tables: Four stored ENR tables with 35 frequencies each (plus one working ENR table).

Smoothing: exponential averaging of gain and noise figure before display according to $D = P(F-1) + M/F$ where D is the display result, prior to conversion to logarithmic form, P is the previous result, M is the latest measurement, and F is the averaging factor (1, 2, 4, 8, 16, 32, 64, 128, 256, or 512). Arithmetic averaging is used during swept operation.

Table 1-2. HP 8970B Noise Figure Meter Supplemental Characteristics (2 of 2)

<p>Rear Panel Outputs: X-Axis and Y-Axis from 0 to 6V. Z-Axis is TTL for pen lift (on an X-Y recorder) and blanking (on an oscilloscope).</p> <p>Plotter Capability: Noise figure and gain versus frequency plot with grid, title and noise figure, gain and frequency axis annotation.</p> <p>Compatible Digital Plotters: HP 7470A, 7475A, 7550A, 7440A and 9872B.</p>

Table 1-3. Noise Figure System Specifications (HP 8970B with HP 8971B and LO) (1 of 2)

Specifications for the Noise Figure Measurement System are the same as the Noise Figure Meter, with the following exceptions. These specifications are valid when any of the recommended system local oscillators (HP 8671B, HP 8672A, HP 8673B [standard], HP 8673C, HP 8340A/B or HP 8341A/B) is used in the Noise Figure Measurement System.

Characteristics	Performance Limits	Conditions
<p>NOISE FIGURE MEASUREMENT</p> <p>Range</p> <p>Instrumentation Uncertainty^{1,2}</p>	<p>0 to 30 dB</p> <p><±0.25 dB</p>	<p>All specifications certified for temperature range of +10 to +40° C</p> <p>For a noise source with an ENR of 14 to 16 dB.</p> <p>For $NF1 + G1 > 5$ dB where NF1 is the noise figure of the device under test and G1 is the gain of the device under test.</p>
<p>GAIN MEASUREMENT</p> <p>Instrumentation Uncertainty^{1,2}</p>	<p><±0.45 dB</p>	<p>For $NF1 + G1 > 10$ dB where NF1 is the noise figure of the device under test and G1 is the gain of the device under test.</p>
<p>INPUT</p> <p>Frequency Range</p> <p>Reducing System Noise Figure with Pre-amplification</p> <p>Noise Figure (maximum)</p> <p style="padding-left: 40px;">SSB1</p> <p style="padding-left: 40px;">SSB2</p> <p style="padding-left: 40px;">SSB3</p> <p>Input SWR</p> <p style="padding-left: 40px;">SSB1</p> <p style="padding-left: 40px;">SSB2</p> <p style="padding-left: 40px;">SSB3</p>	<p>Tunable from 10 to 18000 MHz</p> <p><2 dB + noise figure of the external system</p> <p>≤12 dB + 0.003 dB/MHz (+0.002 dB, opt 020)</p> <p>≤ 21 dB</p> <p>≤ 22 dB</p> <p>≤ 24 dB</p> <p>≤ 28 dB</p> <p>1.7:1 (1.5:1, opt 020)</p> <p>2:1</p> <p>2:1</p>	<p>Low noise external preamplification with net gain 30 dB</p> <p>10 MHz to 1.6 GHz</p> <p>1.6 to 2.4 GHz</p> <p>2.4 to 12 GHz</p> <p>12 to 15 GHz</p> <p>15 to 18 GHz</p> <p>10 MHz to 1.6 GHz</p> <p>1.6 to 2.4 GHz</p> <p>2.4 to 18 GHz</p>

Table 1-3. Noise Figure System Specifications (HP 8970B with HP 8971B and LO) (2 of 2)

<p>GENERAL Power, net weight and dimensions</p>	<p>Sum of HP 8970B, HP 8971B and local oscillator.</p>	
<p>¹ Noise figure accuracy and gain accuracy are dependent on the device under test. Refer to the Preamplifier Selection detailed operating instruction in Section III for more information on computing accuracy for your application.</p> <p>² When making a measurement, the Noise Figure Measurement System must be tuned in the same direction and to the same frequency points used during calibration without skipping any frequency points.</p>		

Table 1-4. Supplemental Characteristics (HP 8970B with HP 8971B)

<p>Supplemental characteristics are intended to provide information useful in applying the instrument by giving typical, but non-warranted, performance parameters.</p>	
<p>Maximum Safe Input Level Maximum Operating Input Power Maximum Net External Gain Sensitivity</p> <p>Double Sideband (DSB) Noise Figure SWR (DSB) Measurement Speed</p> <p>Sweep Speed at Minimum Smoothing (for each Noise Figure Test Set Band) SSB1 140 ms per frequency point SSB2 150 ms per frequency point SSB3 435 ms per frequency point DSB 150 ms per frequency point</p> <p>System Local Oscillator Control</p> <p>Displayed Measurement Frequency Range</p>	<p>+20 dBm (+16 dBm, opt 020), 0 Vdc -20 dBm >60 dB -90 dB (no external gain required, but recommended to lower measurement uncertainty; able to measure its own noise figure with HP 346B/C).</p> <p>18 dB, 2.4 - 26.5 GHz 2.5:1 6 to 9 measurements per second with minimum smoothing.</p> <p>10 to 1600 MHz 1.6 to 2.4 GHz 2.4 to 18 GHz 2.4 to 18 GHz</p> <p>The Noise Figure Meter will control the system local oscillator used in the Noise Figure Measurement System. The Noise Figure Meter will not control a local oscillator that is external to the Noise Figure Measurement System.</p> <p>10 to 99999 MHz</p>

Table 1-5. HP 8971C Specifications

Characteristics	Performance Limits	Conditions
All specifications certified for temperature range of +10°C to +40°C		
Noise Figure SSB Std. & Opt.001 Opt. 002 ¹	≤ 18 dB ≤ 13 dB ≤ 10 dB ≤ 11.5 dB ≤ 14.5 dB ≤ 5.4 dB ≤ 28 dB ≤ 26 dB ≤ 28 dB ≤ 28 dB typical ≤ 32 dB typical	10 MHz - 30 MHz 30 MHz - 100 MHz 100 MHz - 12 GHz 12 GHz - 18 GHz 18 GHz - 26.5 GHz 10 MHz - 1600 MHz 1.6 GHz - 2.4 GHz 2.4 GHz - 15 GHz 15 GHz - 18 GHz 18 GHz - 22 GHz 22 GHz - 26.5 GHz
Input Standing Wave Ratio SSB Std. and Opt. 001 Opt. 002	2.25 2.5 1.5 2 3	10 MHz - 18 GHz 18 GHz - 26.5 GHz 10 MHz - 1600 MHz 1.6 GHz - 18 GHz 18 GHz - 26.5 GHz
Image and Odd Harmonic Rejection SSB	20 dB typical	Applicable only from 2.4 GHz - 26.5 GHz
REMOTE PROGRAMMING	All functions HP-IB programmable except the LINE switch.	
EMC	Meets EN55011:1991 (Group 1, Class A), and EN50082-1:1992.	
GENERAL Operating Temperature Storage Temperature Humidity  Power Requirements: Operating Voltage: 100, 120, 220, or 240 Vac Operating Frequency Range Power Dissipation Dimensions: Height Width Depth Net Weight Shipping Weight	0 to +55°C -40 to +70°C Up to 95% Relative Humidity to 40°C. ±10% 48 - 440 Hz 200 VA Maximum 93 mm (3.68 in) 425 mm (16.75 in) 473 mm (18.63 in) 9.5 kg (21 lb) 11.8 kg (26 lb)	Specifications certified in range of +10°C to +40°C only. 360 - 440 Hz limited to ≤126.5 V For ordering cabinet accessories, the module sizes are 3.5H, 1MW (module width) and 17D.

1. See Table 1-9, footnote #1 pertaining to the HP 8971C Option 002

Table 1-6. HP 8971C Supplemental Characteristics

Supplemental characteristics are intended to provide information useful in applying the instrument by giving typical, but non-warranted, performance parameters.

Electrical Characteristics	Performance Limits	Conditions
Gain (Typical) Std. & Opt. 001 Opt. 002	23 dB Avg. 17 dB Min. 22 dB Avg. 20 dB Min. 27 dB Avg 14 dB Min. -3 dB Avg. -4 dB Min. 0 dB Avg. -2 dB Min. 0 dB Avg. -5.0 Min.	10 MHz - 1600 MHz 1.6 - 2.4 GHz 2.4 - 26.5 GHz 10 - 1600 MHz 1.6 - 2.4 GHz 2.4 - 26.5 GHz
DSB Gain Std. & Opt. 001 Opt. 002	28 dB Min. 4 dB Min.	
DSB Noise Figure (2.4 - 26.5 GHz) Std. & Opt. 001 Opt 002	Same as SSB 21 dB	Negligible LO noise.
DSB SWR Std. and Opt. 001 Opt. 002	Same as SSB 2.5:1	
Maximum Operating RF Noise Input Power Std. & Opt. 001 Opt. 002	-29 dBm -26 dBm -20 dBm	10 - 1600 MHz 1.6 - 26.5 GHz
Maximum Safe RF Input Power Std. & Opt. 001 Opt. 002	-5 dBm +20 dBm	
LO Input Power Minimum: Std. & Opt. 002 Opt. 001	+7 dBm +1 dBm	
Maximum: Std. & Opt. 002 Opt 001	+20 dBm +7 dBm	
Audible Noise Level	<5.5 bels at 1 metre	

**Table 1-7.
Noise Figure System Specifications
(HP 8970B with HP 8971C Std. and Opt. 001)**

Electrical Characteristics	Performance Limits	Conditions
Noise Figure Range Instrumentation Uncertainty^{1,2}	0 to 30 dB ± 0.2 dB plus typical drift of ± 0.015 dB/°C. ± 0.4 dB plus typical drift of ± 0.08 dB/°C.	All specifications certified for temperature range of +10°C to +40°C 10 MHz to 18 GHz 18 to 26.5 GHz. For a noise source with an ENR of 14 to 16 dB. For $NF1 + G1 > 10$ dB where NF1 is the noise figure of the device under test and G1 is the gain of the device under test.
Gain Measurement Instrumentation Uncertainty	$< \pm 0.28$ dB plus typical drift of ± 0.05 dB/°C. ± 0.07 dB/°C	10 MHz to 18 GHz 18 to 26.5 GHz For gains of -6 dB to 30 dB.
Input Frequency Range Noise Figure (maximum) Input SWR	Tunable from 10 to 26500 MHz Same as HP 8971C Same as HP 8971C	
General Power, net weight and dimensions	Sum of HP 8970B, HP 8971C, and local oscillator.	
¹ Noise figure accuracy and gain accuracy are dependent on the device under test. Refer to the Preamplifier Selection Detailed Operating Instruction in Section III for more information on computing accuracy for your application.		
² When making a measurement, the Noise Figure Measurement System must be tuned in the same direction and to the same frequency points used during calibration without skipping any frequency points.		

Table 1-8. Supplemental Characteristics (HP 8970B with HP 8971C and Opt. 001)

Supplemental characteristics are intended to provide information useful in applying the instrument by giving typical, but non-warranted, performance parameters.	
Maximum Safe Input Level Maximum Operating Input Power Maximum Net External Gain Sensitivity Double Sideband (DSB) Noise Figure SWR (DSB) Measurement Speed Sweep Speed at Minimum Smoothing (for each Noise Figure Test Set Band) SSB1 140 ms per frequency point. SSB2 150 ms per frequency point SSB3 435 ms per frequency point DSB 150 ms per frequency point System Local Oscillator Control	-5 dBm, 0Vdc -29 dBm, 10 to 1600 MHz -26 dBm, 1.6 to 26.5 GHz >35 dB -100 dBm (no external gain required, but recommended to lower measurement uncertainty; able to measure its own noise figure with HP 346B/C). Same as Single Sideband Same as Single Sideband 6 to 9 measurements per second with minimum smoothing. 10 to 1600 MHz 1.6 to 2.4 GHz 2.4 to 26.5 GHz 2.4 to 26.5 GHz The Noise Figure Meter will control the system local oscillator used in the Noise Figure Measurement System. The Noise Figure Meter will not control a local oscillator that is external to the Noise Figure Measurement System.
Displayed Measurement Frequency Range	10 to 99999 MHz

**Table 1-9. Noise Figure System Specifications
(HP 8970B with HP 8971C Option 002)¹**

Electrical Characteristics	Performance Limits	Conditions
Noise Figure Range Instrumentation Uncertainty ^{2,3}	0 to 30 dB ± 0.2 dB plus typical drift of ± 0.015 dB/°C.	All specifications certified for temperature range of +10°C to +40°C Assumes the use of a preamplifier with 10 dB noise figure and >20 dB gain. For a noise source with an ENR of 14 to 16 dB. For NF1 + G1 > 10 dB where NF1 is the noise figure of the device under test and G1 is the gain of the device under test.
Gain Measurement Instrumentation Uncertainty	$< \pm 0.28$ dB plus typical drift of ± 0.05 dB/°C. ± 0.07 dB/°C	10 MHz to 18 GHz 18 to 26.5 GHz For gains of -6 dB to 30 dB.
Input Frequency Range Noise Figure (maximum) SSB1 SSB2 SSB3	Tunable from 10 to 26500 MHz ≤ 12 dB + 0.003 dB/MHz ≤ 28 dB ≤ 26 dB ≤ 28 dB ≤ 28 dB typical ≤ 32 dB typical	10 MHz to 1.6 GHz 1.6 to 2.4 GHz 2.4 to 15 GHz 15 to 18 GHz 18 to 22 GHz 22 to 26.5 GHz
Input SWR SSB1 SSB2 SSB3 General Power, net weight and dimensions	1.5:1 2:1 2:1 3:1 Sum of HP 8970B, HP 8971C, and local oscillator.	10 MHz to 1.6 GHz 1.6 to 2.4 GHz 2.4 to 18 GHz 18 to 26.5 GHz

¹Typically, a preamplifier with gain greater than 10 dB and noise figure <20 dB is necessary to align the HP 8971C Opt. 002 input filter during calibration at frequencies greater than 18 GHz.

²Noise figure accuracy and gain accuracy are dependent on the device under test. Refer to the Preamplifier Selection Detailed Operating Instruction in Section III for more information on computing accuracy for your application.

³When making a measurement, the Noise Figure Measurement System must be tuned in the same direction and to the same frequency points used during calibration without skipping any frequency points.

Table 1-10. Supplemental Characteristics

<p>Supplemental characteristics are intended to provide information useful in applying the instrument by giving typical, but non-warranted, performance parameters.</p>	
<p>Maximum Safe Input Level</p> <p>Maximum Operating Input Power</p> <p>Maximum Net External Gain</p> <p>Sensitivity</p> <p>Double Sideband (DSB) Noise Figure</p> <p>SWR (DSB)</p> <p>Measurement Speed</p> <p>Sweep Speed at Minimum Smoothing (for each Noise Figure Test Set Band)</p> <p>SSB1 140 ms per frequency point</p> <p>SSB2 150 ms per frequency point</p> <p>SSB3 435 ms per frequency point</p> <p>DSB 150 ms per frequency point</p> <p>System Local Oscillator Control</p> <p>Displayed Measurement Frequency Range</p>	<p>+20 dBm, 0Vdc</p> <p>-20 dBm, 10 to 26500 MHz</p> <p>>60 dB</p> <p>-90 dB (no external gain required, but recommended to lower measurement uncertainty; able to measure its own noise figure with HP 346B/C but won't align its filter during calibration without an amplifier above 18 GHz).</p> <p>21 dB, 2.4 - 26.5 GHz with negligible LO noise.</p> <p>2.5:1</p> <p>6 to 9 measurements per second with minimum smoothing.</p> <p>10 to 1600 MHz</p> <p>1.6 to 2.4 GHz</p> <p>2.4 to 26.5 GHz</p> <p>2.4 to 26.5 GHz</p> <p>The Noise Figure Meter will control the system local oscillator used in the Noise Figure Measurement System. The Noise Figure Meter will not control a local oscillator that is external to the Noise Figure Measurement System.</p> <p>10 to 99999 MHz</p>

Table 1-11.
HP 8970B or HP 8970B Option 020 Recommended Test Equipment

Equipment	Critical Specifications	Recommended Model	Use ¹
Amplifier 1, Wideband	Frequency Range: 0.1 to 1300 MHz Gain: 26dB Output Power for 1 dB Gain Compression: +7 dBm	HP 8477D Option 010	P
Amplifier 2, Wideband	Frequency Range: 0.1 to 1300 MHz Gain: 48dB Output Power for 1 dB Gain Compression: >+15 dBm	HP 8447F Option 010	P
Attenuator, 1 dB Step	Steps: 1 dB Attenuation Range: 0 to 11 dB Frequency Range: 10 to 1600 MHz	HP 8494A Option 001	P,A
Attenuator, 10 dB Step	Step Size: 10 dB Attenuation: 0 to 70 dB Frequency Range: 10 to 1600 MHz	HP 8495A Option 001	P
Attenuator, Fixed	Attenuation: 6 dB Frequency Range: 10 to 1600 MHz	HP 8491A Option 006	P,A
Attenuator, Fixed (2 required)	Attenuation: 10 dB Frequency Range: 10 to 2047 MHz	HP 8491A Option 010	P
Attenuator, Fixed	Attenuation: 6 dB Frequency Range: 10 to 1600 MHz	HP 8493A Option 006	A
Attenuator, Fixed	Attenuation: 20 dB Frequency Range: 10 to 1600 MHz	HP 8491A Option 020	P
Calculator	Divide Multiply Square Root Programmable	HP 41CV	P,A
Controller	HP-IB compatibility as defined by IEEE Standard 488 and the identical ANSI Standard MC1.1:SH1,AH1,T2,TE0,L2,LE0,SR0,RL0,PP0,DC0,DT0,C1,2,3,4,5	HP 9000 Series 200 or 300	O,P,T
Digital Voltmeter	DC Voltage Range: Up to 100V Resolution: 1 μ V (high resolution mode, 1V dc range) Accuracy: $\pm 0.003\%$ of reading +4 counts (in high resolution mode) Single Trigger capability	HP 3455A or 3456A	P,A,T
Directional Coupler	Frequency Range: 1380 to 2300 MHz	HP 778D	P

¹ A= Adjustments, P=Performance, T=Troubleshooting, O=Operational Verification

Table 1-12.
HP 8970B or HP 8970B Option 020 Recommended Test Equipment

Equipment	Critical Specifications	Recommended Model	Use ¹
Filter, Low Pass	Insertion Loss: < 1 dB below 0.9 times cut-off frequency. Cut-off Frequency: 1200 MHz Rejection: >50 dB at 1.25 times cut-off frequency	HP 360B or RLC F-10-1500	P,A
Frequency Counter	Range: 10 to 6000 MHz Resolution: 1 kHz	HP 5340A or 5343A	A
Logic Analyzer	Input lines: 43 Timing Analysis: 16 lines	HP 1630A, 1630D, or 1631D	T
Noise Source	Power Required: +28V ENR: 15.2 dB Connector: Type N (male)	HP 346B Option 001 or HP 346C	O,P,T, A
Oscilloscope	Inputs: Two Channel (A vs B or X vs Y) and Z-Axis	HP 54111D	A,T
Power Meter	Uncertainty: ± 0.02 dB Mode: dB Relative	HP 436A	P,A,T
Power Sensor	Frequency Range: 10 to 4000 MHz Power Range: 0.1 nW to 10 μ W SWR: (30 to 4000 MHz): 1.15	HP 8484A or HP 8481D	P,A,T
Power Sensor	Frequency Range: 10 to 4000 MHz Power Range: 10 μ W to 100 mW SWR: (30 to 4000 MHz): 1.18	HP 8481A	P,A,T
Power Splitter	Frequency Range: 10 to 2047 MHz	HP 11667A	P,A
Signal Generator	Frequency Range: 10 to 2047 MHz Frequency Accuracy: ± 1 kHz Output Level: +13 dBm	HP 8340B, 8672A, or 8673B	O,T,P, A
Spectrum Analyzer	Frequency Range: 10 to 2047 MHz	HP 8566B	A
Sweep Oscillator	Frequency Range: 20 to 2400 MHz Attenuation: 70 dB in 10 dB steps	HP 8620C/ 86222B Option 002, HP 8350B HP 8340B/41B	P,A,O
SWR Bridge	Frequency Range: 10 to 2047 MHz Directivity: 40 dB	Wiltron 60N50	P

Table 1-13. HP 8971C Recommended Test Equipment

Equipment	Critical Specifications	Recommended Model	Use ¹
Attenuator, Fixed	Attenuation: 10 dB Frequency Range: 0.010 to 26.5 GHz	HP 8493C Option 010	P
Cable, IF Output	No substitute	HP 11793-60006	P,C
Cable, LO Input	No substitute	HP 08971-60126	P,C
Coaxial Detector	Compatible with the HP 8757E	HP 85025B	P
Digital Voltmeter		HP 3456A	A,T
Directional Bridge	Compatible with the HP 8757E	HP85027B	P
Noise Figure Meter	Compatible with the HP 8971C	HP 8970B	P,T,O
Noise Source	Frequency Range: 0.010 to 26.5 GHz	HP 346C	P,T,O
Oscilloscope		HP 54111D	T
Power Meter		HP 437B	T
Power Sensor	Frequency Range: 0.050 to 26.5 GHz Power Range: 1 μ W to 100 mW	HP 8485A	T
Power Splitter	Frequency Range: 0.010 to 26.5 GHz	HP 11667B	P
Scalar Network Analyzer		HP 8757E	P
Signal Generator (2 required)		HP 8340B/41B, 8671B, 8672A, 8673B/C/E/G	P,T,O
Signature Multimeter		HP 5005A/B, 5006A	T
SMA-male Coaxial Short/Open	Calibration standard for HP 8757E	HP 85037-60001	P
Spectrum Analyzer	Frequency Range: 0.01 to 26.5 GHz	HP 8566B	T

¹ A= Adjustments, P=Performance, T=Troubleshooting, O=Operational Verification

Table 1-14. HP 8971B Recommended Test Equipment

Equipment	Critical Specifications	Recommended	Use
Attenuator	Attenuation: 10 dB Frequency Range: 10 to 18000 MHz	HP 8491B Opt. 010	P
Digital Voltmeter		HP 3456A	P, A
Dual Directional Coupler	20 dB attenuation on reflected and incident ports. Frequency: 2 - 18 GHz frequency Directivity: >26 dB directivity	HP 11692D	P
Oscilloscope		HP 54200A/D, HP 1980B or HP 1740	P
Noise Figure Meter	No substitute	HP 8970B	P
Noise Source	Frequency Range 10 - 18000 MHz	HP 346B/C	P
Power Meter (2)	Uncertainty: +/- 0.02 dB Mode: dB relative	HP 436A (2)	P

Table 1-14. HP 8971B Recommended Test Equipment (Cont'd)

Equipment	Critical Specifications	Recommended	Use
Power Sensor (2)	Frequency range: 0.1 - 18 GHz Power range: 1 mW to 3W 1000W peak	HP 8484A (2)	P
Signature Multimeter		HP5005A/B, HP5006A	T
Spectrum Analyzer	.01 to 18 GHz	HP 8566B	T
Synthesized CW Generator	2 - 18 GHz	HP 8671B	P, T
Synthesized Signal Generator	.01 - 18 GHz	HP 8340B/41B	P, T
SWR Bridge	Frequency range: 10 - 1500 MHz Directivity: 40 dB	Wiltron 60N50	P
SMA Coaxial Open	Made from following parts: HP 1250-0196 Body HP 1250-0016 Snap Ring HP 1250-0198 Nut		P
SMA Coaxial Short	50 Ohm	HP 11512A	P
Controller			C

SECTION II INSTALLATION

2-1. INTRODUCTION

This section provides the information needed to install the Noise Figure Meter. Included is information pertinent to initial inspection, power requirements, line voltage selection, power cables, interconnection, environment, instrument mounting, storage and shipment. In addition, interconnect information for the Noise Measurement Measurement System is provided.

2-2. INITIAL INSPECTION

WARNING

To avoid hazardous electrical shock, do not perform electrical tests when there are signs of shipping damage to any portion of the outer enclosure (covers, panels, meters).

Inspect the shipping container for damage. If the shipping container or cushioning material is damaged, it should be kept until the contents of the shipment have been checked for completeness and the instrument has been checked mechanically and electrically. The contents of the shipment should be as shown in Figure 1-1. Procedures for checking electrical performance are given in Section IV. If the contents are incomplete, if there is mechanical damage or defects, or if the instrument does not pass the electrical performance tests, notify the nearest Hewlett-Packard office. If the shipping container is damaged or the cushioning material shows signs of stress, notify the carrier as well as the Hewlett-Packard office. Keep the shipping materials for the carrier's inspection.

2-3. PREPARATION FOR USE

WARNING

If this instrument is not used as specified, the protection provided by the equipment could be impaired. This instrument must be used in a normal condition only (in which all means for protection are in tact).

2-4. Power Requirements

The Noise Figure Meter requires a power source of 100, 120, 220 or 240 Vac, +10% to -10%, 48 to 66 Hz single phase. Power consumption is 150 VA maximum.

CAUTION

Mains supply voltage fluctuations should not exceed +/- 10% of the nominal selected line voltage.

2-5. Line Voltage and Fuse Selection

CAUTION

Before switching on this instrument, make sure that the line voltage selector board is set to the voltage of the power supply (refer to Figure 2-1) and the correct fuse is installed. Check that the power supply voltage is in the specified range.

WARNING

For continued protection against fire hazard, replace the line fuse only with the same type and line rating as detailed below.

Instrument	Supply Voltage	Fuse Type
HP 8970B	100 -120 Vac	F 1.5 A 250 V
HP 8970B	220 - 240 Vac	F 1.0 A 250 V
HP 8971C	100 - 120 Vac	F 2.0 A 250 V
HP 8971C	220 - 240 Vac	F 1.5 A 250 V

The use of other fuses or materials is prohibited.

2-6. Power Cables

WARNING

Appliance coupler (mains input power cord) is the power disconnect device. Do not position the instrument such that access to the coupler is impaired.

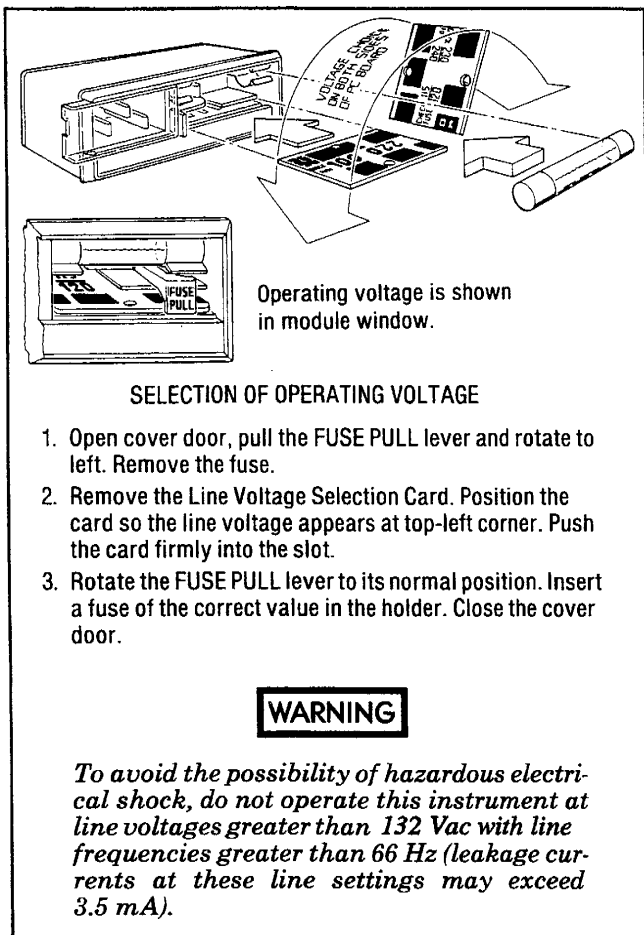

Figure 2-1. Line Voltage and Fuse Selection

This instrument is equipped with a three-wire power cable. When connected to an appropriate ac power receptacle, this cable grounds the instrument cabinet. The power cable plug shipped with each instrument depends on the country of destination. Refer to Figure 2-2 for the part numbers of the power cables available.

2-7. Address Selection **HP-IB**

The Noise Figure Meter uses HP-IB and System Interface Bus (SIB) addresses. The HP-IB address is used when the Noise Figure Meter is accessed by an external controller. SIB addresses are used when the Noise Figure Meter acts as a controller to access other devices. When the Noise Figure Meter is shipped from the factory, it assumes that devices are set to the addresses shown in Table 2-1.

Both HP-IB and SIB addresses are selected by Special Function from the front panel. Refer to HP-IB and System Interface Bus (SIB) Addresses, and System Interface Bus Control in the detailed operating instructions in Section III for additional information.

Valid HP-IB and SIB addresses are 0 through 30. Refer to Table 2-2 for decimal equivalents of the ASCII Talk and Listen address codes.

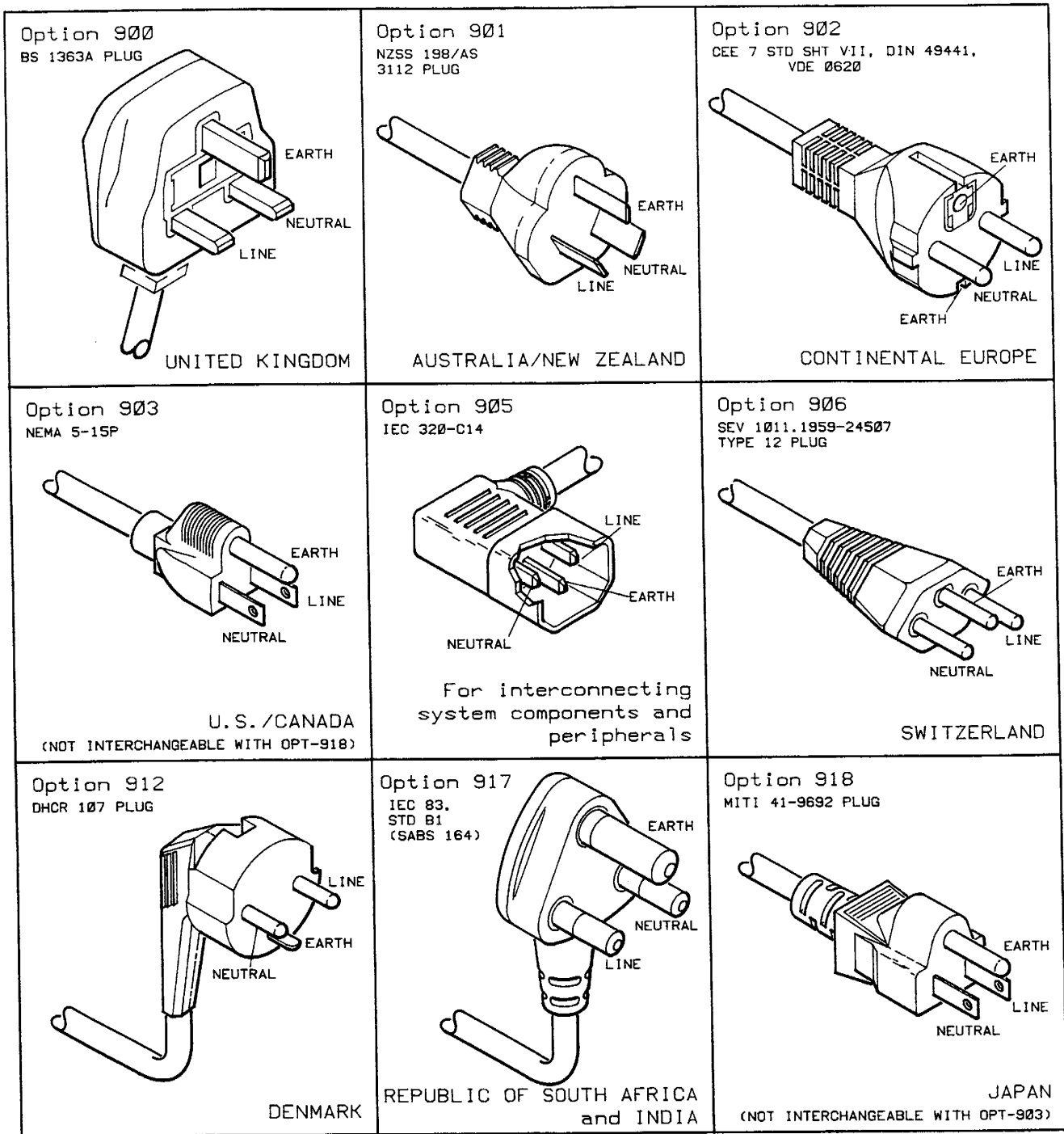

Figure 2-2. Power Cables and Mains Plug Options

Table 2-1. Noise Figure Meter Factory Set Addresses

Instrument	HP-IB Address	SIB Address
Noise Figure Meter	8	
Plotter		5
System Interface Bus		8
Noise Figure Test Set		10
Pass Control Device		16
System Local Oscillator		19

2-8. Interconnections

Interconnection data for the Hewlett Packard Interface Bus (HP-IB) and the System Interface Bus (SIB) is identical. See Figure 2-3.

2-9. HP 8970S/T/U Noise Figure Measurement System

The HP 8970S/T/U Noise Figure Measurement System consists of the Noise Figure Meter, the Noise Figure Test Set and a System Local Oscillator. Interconnection data for the Noise Figure Measurement System is provided in Figure 2-4. If the System Local Oscillator is a free-running source, a coarse tune calibration must be performed. Refer to the Noise Figure Test Set YIG Filter Calibration Detailed Operating Instruction in Section III for the coarse tune calibration procedure. The coarse tune calibration is not needed if a synthesizer is used for the local oscillator.

2-10. Mating Connectors

Interface Connector. The HP-IB and SIB mating connector is shown in Figure 2-3. Note that two securing screws are metric.

Coaxial Connectors. Coaxial mating connectors used with the Noise Figure Meter should be 50 ohm BNC, or type N male connectors. 50Ω type N and APC-3.5 male coaxial connectors are used with the Noise Figure Test Set.

2-11. Operating Environment

The operating environment for the Noise Figure Meter should be within the following limitations:
 Temperature 0 to +55°C
 Humidity <95% relative
 Altitude <4570 metres (15 000 feet)

2-12. Bench Operation

The instrument cabinet has plastic feet and fold-away tilt stands for convenience in bench operation. (The plastic feet are shaped to ensure self-aligning of the

instruments when stacked with other HP equipment.) The tilt stands raise the front of the instrument for easier viewing of the front panel.

Table 2-2. ASCII Address Codes to Decimal Equivalents

ASCII Address Codes		Decimal Equivalents
LISTEN	TALK	
SP	@	00
!	A	01
"	B	02
#	C	03
\$	D	04
%	E	05
&	F	06
'	G	07
(H	08
)	I	09
*	J	10
+	K	11
,	L	12
-	M	13
.	N	14
/	O	15
0	P	16
1	Q	17
2	R	18
3	S	19
4	T	20
5	U	21
6	V	22
7	W	23
8	X	24
9	Y	25
:	Z	26
;	[27
<	\	28
=]	29
>	^	30

2-13. Rack Mounting

WARNING

The Noise Figure Meter weighs 18.5 kg (40 lb), therefore, care must be exercised when lifting to avoid personal injury. Use equipment slides when rack mounting.

Rack mounting information is provided with the rack mounting kits. If the kits were not ordered with the instrument as options, they may be ordered through the nearest Hewlett-Packard office. Refer to the paragraph entitled Mechanical Options in Section I.

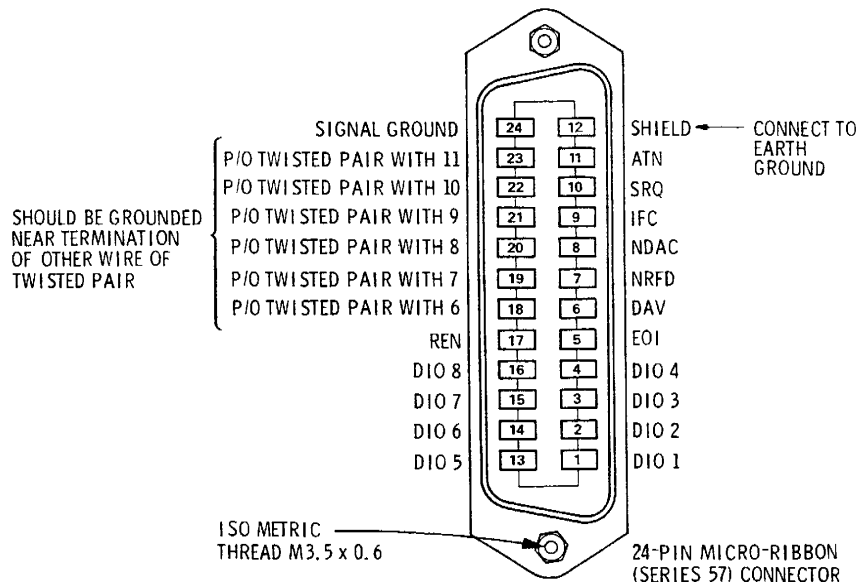

Logic Levels

The Hewlett-Packard Interface Bus and System Interface Bus Logic Levels are TTL compatible, i.e., the true (1) state is 0.0 Vdc to +0.4 Vdc and the false (0) state is +2.5 Vdc to +5.0 Vdc.

Programming and Output Data Format

Refer to Section III, Operation.

Mating Connector

HP 1251-0293; Amphenol 57-30240.

Mating Cables Available

HP 10833A, 1 metre (3.3 ft), HP 10833B, 2 metres (6.6 ft)
 HP 10833C 4 metres (13.2 ft), HP 10833D, 0.5 metres (1.6 ft)

Cabling Restrictions

1. A Hewlett-Packard Interface Bus system or System Interface Bus system may contain no more than 2 metres (6.6 ft) of connecting cable per instrument.
2. The maximum accumulative length of connecting cable for any Hewlett-Packard Interface Bus system or System Interface Bus system is 20.0 metres (65.6 ft).

Figure 2-3. Hewlett-Packard Interface Bus and System Interface Bus Connections

2-14. RECORDING IF ATTENUATOR VALUES

IF attenuator data is used to correct the gain readings during the gain measurement. It is critical that the Noise Figure Meter know the value of its internal IF attenuators in order to meet its gain accuracy specification. Recording these values ensures a backup record is kept if a nonvolatile memory failure should occur. *HP recommends that IF attenuator values be recorded in Table 4-1 when the Noise Figure Meter is turned on for the first time and after its annual calibration.* Table 4-1 is located in the Gain Measurement Uncertainty Performance Test in Section IV. This performance test also includes a procedure for reading the IF attenuator values. Refer to the "Entering IF Attenuator Values" portion of the performance test.

2-15. STORAGE AND SHIPMENT

2-16. Environment

The instrument should be stored in a clean, dry environment. The following environmental limitations apply to both storage and shipment:

- Temperature -55°C to +75°C
- Humidity <95% relative
- Altitude <15 300 metres (50 000 feet)

2-17. Packaging

Tagging for Service. If the instrument is being returned to Hewlett-Packard for service, please complete one of the blue repair tags located at the back of this manual and attach it to the instrument.

Original Packaging. Containers and materials identical to those used in factory packaging are available through Hewlett-Packard offices. Mark the container "FRAGILE" to assure careful handling. In any correspondence, refer to the instrument by model number and full serial number.

Other Packaging. The following general instructions should be used for re-packaging with commercially available materials:

- a. Wrap the instrument in heavy paper or plastic. (If shipping to a Hewlett-Packard office or service center, complete one of the blue tags and attach it to the instrument.)
- b. Use a strong shipping container. A double-wall carton made of 2.4 MPa (350 psi) test material is adequate.
- c. Use enough shock-absorbing material (75 to 100 mm layer; 3 to 4 inches) around all sides of the instrument to provide firm cushion and prevent movement in the container. Protect the front panel with cardboard.
- d. Seal the shipping container securely.
- e. Mark the shipping container "FRAGILE" to assure careful handling.

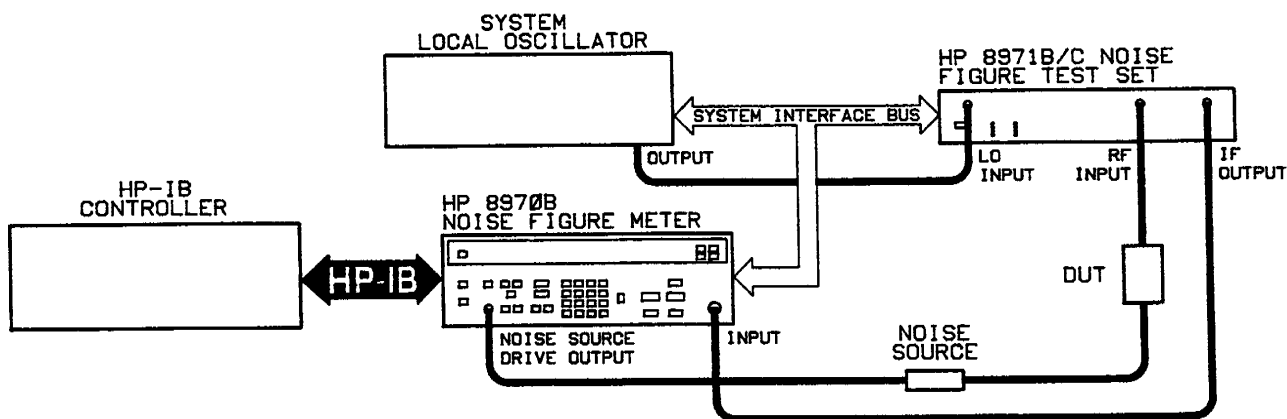

Figure 2-4. Noise Figure Measurement System Interconnections

2-18. OPERATING ENVIRONMENT

This instrument is designed for indoor use only.

The instrument may be operated at temperatures from 0°C to +55°C at altitudes up to 4600m (15,000 ft.). The instrument may be operated in environments up to 95% relative humidity to 40°C, but it should be protected from temperature extremes which may cause condensation.

CAUTION

This instrument is designed for use in Installation Category II and Pollution Degree 2 per IEC1010 and 644 respectively.

2-19. Internal Fuses

WARNING

No operator serviceable parts inside, Refer servicing to qualified personnel. To prevent electrical shock do not remove covers.

The internal fuses used in the HP 8971C are listed below, and are non-operator replaceable Cartridge, Fast Blow fuses.

Table 2-3. 8971C Internal Fuses

Fuse	Current	Voltage	Type
F1	3.0 A	250 V	F
F2	3.0 A	250 V	F
F3	2.0 A	250 V	F
F4	3.0 A	250 V	F
F5	3.0 A	250 V	F
F6	1.0 A	250 V	F
F7	0.5 A	250 V	F
F8	3.0 A	250 V	F

The internal fuse used in the HP 8970B is listed below, and is a non-operator replaceable plug-in Very Fast-Acting fuse.

Table 2-4. 8970B Internal Fuse

Fuse	Current	Voltage	Type
F1	3.0 A	125 V	FF

2-20. Cleaning

To clean the instrument: Use a soft , clean damp cloth to clean the front-panel and side covers.



SECTION III OPERATION

3-1. INTRODUCTION

This section provides complete operating information for the Noise Figure Meter. Included in this section are both general and detailed operating instructions, detailed descriptions of the front and rear panel, local and remote operator's checks, and operator's maintenance procedures. Also provided are operation and operators checks for the Noise Figure Measurement System (Noise Figure Meter, Noise Figure Test Set and System Local Oscillator). Operation of the Noise Figure Measurement System is described under Measurement Modes 1.5 through 1.9.

3-2. Operating Characteristics

Table 3-1 briefly summarizes the major operating characteristics of the Noise Figure Meter. This table is not intended to be an in-depth listing of all operations and ranges but gives a rough idea of the instrument's capabilities. For more information on the Noise Figure Meter's capabilities, refer to Table 1-1, Specifications and Table 1-2, Supplemental Characteristics. For information on HP-IB capabilities, refer to the summary contained in Table 3-3, Message Reference Table.

3-3. Local Operation

Information covering front panel operation of the Noise Figure Meter is given in the sections described below. To rapidly learn the operation of the instrument, begin with Simplified Operation and Operator's Checks. Once familiar with the general operation of the instrument, use the Detailed Operating Instructions for in-depth and complete information in operating the Noise Figure Meter.

CAUTION

The local oscillator power must be selected for the type of HP 8971B/C in use.

An HP 8971B requires +6 dBm, an HP 8971C standard or Option 002 requires +10 dBm at 26.5 GHz (+8 dBm is adequate below 22 GHz), and an HP 8971C Option 001 should have only +1 dBm. Use special function 42.5 to change the local oscillator power if necessary.

General Operating Information. Instructions relating to the Noise Figure Meter turn-on procedure and various keystroke sequences are presented to acquaint the user with the general operation of the instrument.

Simplified Operation. The instructions located on the inside of this fold provide a quick introduction to front panel operation of the Noise Figure Meter. These instructions are designed to rapidly acquaint the new user with basic operating procedures and therefore are not an exhaustive listing of all Noise Figure Meter functions. However, an index to the Detailed Operating Instructions appears opposite the fold to direct the operator to the more complete discussion of the topic of interest.

Panel Features. Front and rear panel features are described in detail in Figures 3-1 through 3-8.

Detailed Operating Instructions. The Detailed Operating Instructions provide the complete operating reference for the Noise Figure Meter user. The instructions are organized alphabetically by subject and are placed at the end of this section for easy reference. They are indexed by function in Table 3-2.

Operating Information Pull-Out Cards. The Operating Information pull-out cards are three flexible plastic reference sheets located in a tray below the front panel. They contain a listing of user special functions, HP-IB output formats, error codes, and measurement modes.

3-4. Remote Operation

The Noise Figure Meter is capable of remote operation via the Hewlett-Packard Interface Bus (HP-IB). In remote operation, the Noise Figure Meter operates in one of two modes: normal talker listener mode and talk only mode. The remote operation instructions provide information pertinent to HP-IB operation when the Noise Figure Meter is in the normal talker/listener mode or the talk only mode. Included are discussions on capabilities, addressing input and output formats, the status bytes and service requests. At the end of the discussion is a complete summary of all codes and formats.

In addition to the section described above, information concerning remote operation appears in several other locations. The controller capability of the Noise Figure Meter is described in the Detailed Operating Instructions. A summary of HP-IB codes and output formats appear on one of the Operating Information pull-out cards. Numerous examples of program strings appear throughout the Detailed Operating Instructions.

3-5. Operator's Checks

Operator's Checks are procedures designed to verify the proper operation of the Noise Figure Meter's main functions. Also, Operator's Checks are provided for the Noise Figure Measurement System. Three procedures are described below.

Basic Functional Checks. This procedure requires only a noise source, an oscilloscope (or a display module), and interconnecting cables. It assures that most front panel controlled functions are being properly executed by the Noise Figure Meter.

HP-IB HP-IB Functional Checks. These procedures require an HP-IB compatible computing controller, an HP-IB interface and connecting cable. The HP-IB Functional Checks assume that front panel operation of the Noise Figure Meter, has been verified by performing the Basic Functional Checks. The procedures check all of the applicable bus messages summarized in Table 3-3.

Noise Figure Measurement System Check. This procedure only requires the Noise Figure Measurement System (Noise Figure Meter, Noise Figure Test Set and System Local Oscillator) and a noise source. The check assures that the Noise Figure Measurement System is operating properly.

3-6. Operator's Maintenance

WARNING

For continued protection against fire hazard, replace the line fuse with a 250V fuse of the same rating only. Do not use repaired fuses or short-circuited fuse-holders.

Operator's maintenance consists of replacing blown fuses and cleaning the air filter.

The primary power fuse is located within the Line Power Module (A15). Refer to Figure 2-1 for instructions on how to change the fuse.

The rear panel fan has a filter inserted from the outside for ease of cleaning or replacement. To service the filter, disconnect power from the instrument and remove the filter by pulling it from the rear of the fan. To clean the filter, hold it under running water or wash it in warm soapy water and then rinse it in clear water. Dry the filter thoroughly before putting it back into place.

NOTE

The internal battery should be replaced once a year by qualified service personnel. In the Service Manual, Section VIII, is a procedure for replacing the battery. The part number of the Service Manual is on the title page of this manual.

If the instrument does not operate properly and is being returned to Hewlett-Packard for service, please complete one of the blue tags located at the end of this manual and attach it to the instrument. Refer to Section II for packaging instructions.

3-7. GENERAL OPERATING INSTRUCTIONS

WARNING

Before the Noise Figure Meter is switched on, all protective earth terminals, extension cords, auto-transformers, and devices connected to the instrument should be connected to a protective earth grounded socket. Any interruption of the protective earth grounding will cause a potential shock hazard that could result in personal injury.

CAUTION

Before the Noise Figure Meter is switched on, it must be set to the same line voltage as the power source or damage to the instrument may result.

The Noise Figure Test Set must be grounded through the third wire on the power cord to avoid instrument damage to critical microwave amplifier circuitry.

3-8. Turn-On

Turn-On Procedures. If the Noise Figure Meter is already plugged in, set the LINE switch to ON.

If the power cable is not plugged in, follow these instructions:

1. Check the line voltage selection card for correct voltage selection.
2. Check the fuse for correct current rating. The current rating is printed on the line power module label.
3. Plug in the power cable.

On the front panel, set the LINE switch to ON.

Turn On (cont'd)

Turn-on Sequence. The Noise Figure Meter performs a quick internal check at turn-on. During this check, all front panel indicators light for approximately two seconds to allow a quick visual inspection of each front panel display annunciator and display segment. If a failure is detected, an error code will appear in the NOISE FIGURE display to indicate the nature of the failure. For error codes E10 through E49, and E80, refer to Error Messages and Recovery in the Detailed Operating Instructions. For error codes E60 through E80, refer to Section VIII (Service)*.

If the memory check was successful, "Ctrl" will appear in the INSERTION GAIN display and "on" or "OFF" will appear in the NOISE FIGURE display. If the Noise Figure Meter is the system controller on the System Interface Bus (Special Function 48.0) "on" will be displayed. If the Noise Figure Meter is not the system controller on the System Interface Bus (Special Function 48.1) "OFF" will be displayed. Then, "Fr" will appear in the INSERTION GAIN display and "CAL" will appear in the NOISE FIGURE display for approximately five seconds while the Noise Figure Meter performs a frequency calibration.

After the frequency calibration, the instrument powers up to the last front panel configuration prior to being turned off. Refer to Preset Conditions and Power-Up Sequence in the Detailed Operating Instructions for additional information.

NOTE

An internal battery is used to retain data in continuous memory when the Noise Figure Meter is turned off. At turn-on, the Noise Figure Meter restores the same front panel configuration that was present when last powered down. Nine storage registers, the ENR tables and other information are also restored.

3-9. Keystroke Sequences

The Noise Figure Meter's functions can be selected in any order. However, each function selection

*Section VIII, Service, is in the Service Manual. The part number of the Service Manual is on the title page of this manual.

requires a prescribed sequence of keystrokes. A keystroke sequence can be either a single keystroke or several keystrokes that must be entered in a specific order. Functions requiring only single keystroke are: PRESET, LOCAL, UNCORRECTED NOISE FIGURE, CORRECTED NOISE FIGURE AND GAIN, INCREASE, DECREASE, AUTO, SINGLE, \blacktriangle and \blacktriangledown . The CALIBRATE function requires that the calibrate key be pressed twice.

Frequency parameters are entered in a Function-Data-ENTER format. Data entered following a function will be interpreted for that function only if terminated with the ENTER key. Data previously entered remains unaffected until the new data entry is terminated by pressing the ENTER key. If another function key is pressed before the data entry is terminated, that entry will be rejected and the last valid data for the function will remain active.

The STORE and RECALL functions are used to store and recall instrument configurations or Excess Noise Ratio (ENR) tables. When used to store and recall instrument configurations, the STORE and RECALL functions are entered in a Function-Data format. It is not necessary to use the ENTER key to terminate data entry. However, ENTER has no effect if it is used. Data is a single digit register number (0 through 9). When used to store and recall ENR tables, the STORE and RECALL functions are entered in a Function-ENR-Data format. It is not necessary to use the ENTER key to terminate data entry. However, ENTER has no effect if it is used. ENR is the ENR key. Data is a single digit table number (1 through 4).

Special Functions are entered in a Code-SPECIAL FUNCTION format. The code consists of a prefix, decimal, and suffix. 7.1 is an example of a special function code where 7 is the prefix and 1 is the suffix. If the suffix is zero, the zero and the decimal point can be omitted when entering the code. For example, 7 SPECIAL FUNCTION is equivalent to 7.0 SPECIAL FUNCTION. A Code-SPECIAL FUNCTION-Data-ENTER format is used to activate and enter data for special functions that require data entry.

FRONT PANEL FEATURES

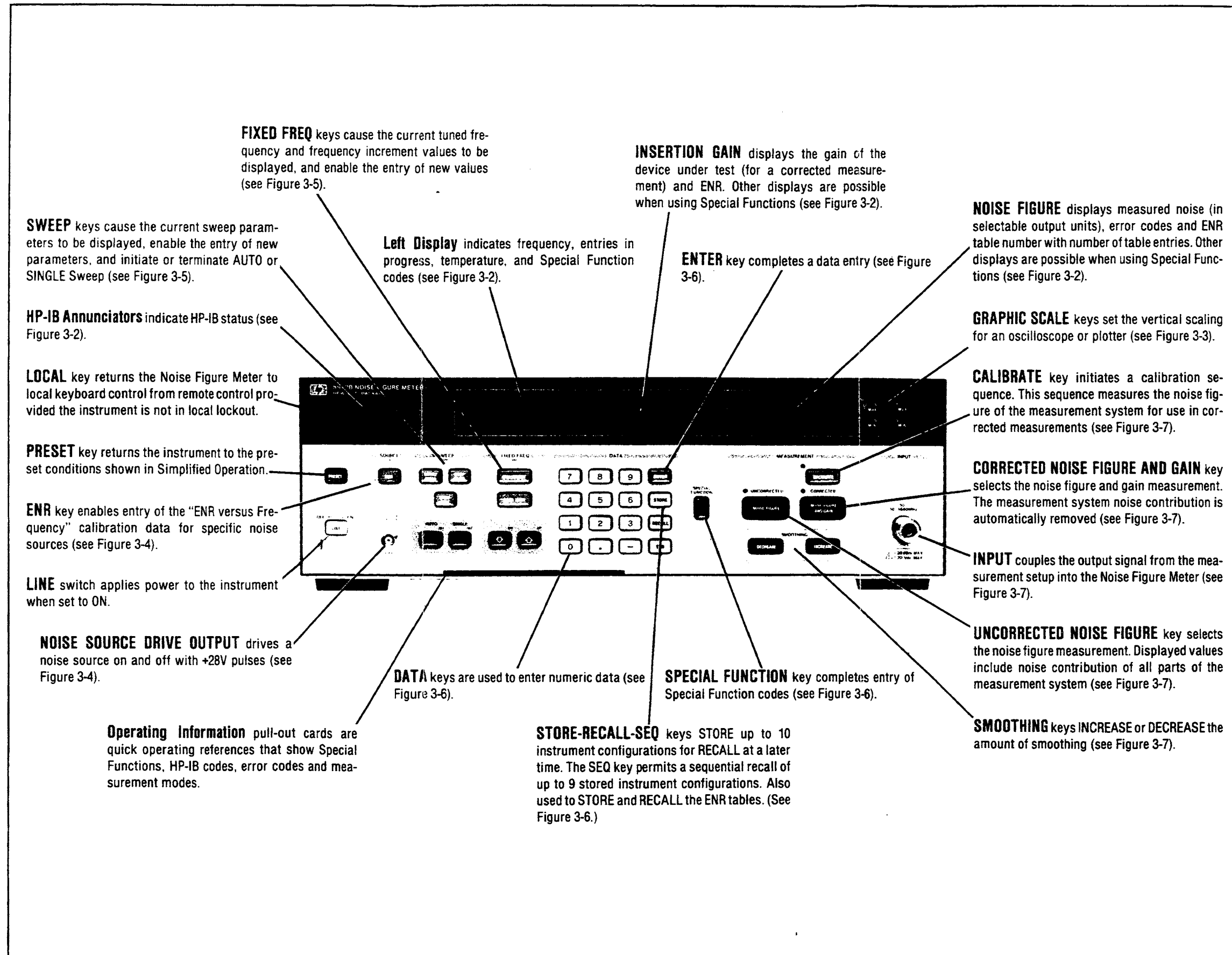

Figure 3-1. Front-Panel Features

SIMPLIFIED OPERATION PRESET

Press **PRESET** This sets the front panel functions to the following:

FREQUENCY = 30 MHz STEP SIZE = 20 MHz
 FREQ INCR = 20 MHz SMOOTHING = 1
 START FREQ = 10 MHz MEASUREMENT = UNCORRECTED NOISE FIGURE
 STOP FREQ = 1600 MHz CALIBRATE = Off
 SWEEP = Off

In addition, default values are entered for some Special Functions. Refer to Table 3-14, Special Function Summary.

MEASUREMENT MODES

The Noise Figure Meter has ten Measurement Modes (1.0 through 1.9). Mode 1.0 is used for RF Measurements ranging from 10 to 1600 MHz (2047 MHz, opt 020) and requires no external equipment (except a noise source). Modes 1.1 through 1.4 are used for microwave measurements up to 99999 Mhz and require the system local oscillator (LO). Modes 1.1 and 1.2 also require an external mixer (the mixer is part of the device-under-test (DUT) in modes 1.3 and 1.4). Modes 1.5 through 1.9 are also for microwave measurements. Mode 1.5 is used for measurements from 10 to 26500 MHz. Modes 1.6 through 1.9 are for measurements up to 99999 MHz. Modes 1.5 through 1.9 require use of the Noise Figure Test Set and the system LO. Along with the Noise Figure Meter, the Noise Figure Test Set and the system LO form the Noise Figure Measurement System, which extends the range of the Noise Figure Meter from 1600 MHz (2047 MHz, opt 020) to 26500 MHz. Modes 1.6 through 1.9 require use of a second LO (user-controlled). The user-controlled LO is used with the Noise Measurement System, and along with an external mixer, extend the range of the Noise Figure Measurement System from 26500 to 99999 MHz. Modes 1.6 and 1.7 require an external mixer (the mixer is part of the DUT in modes 1.8 and 1.9). Refer to the operating information pull-out card and Measurement Modes in the Detailed Operating Instructions for more information. A Measurement Mode must be selected before performing a calibration or measurement. (Mode 1.0 is selected with PRESET.) Simplified Operation assumes that Mode 1.0 is selected

FIXED FREQUENCY TUNING

Fixed frequency parameters are selected in a Function-Data-ENTER format. For example, to set the tuned frequency to 500 MHz and the frequency increment to 100 MHz:

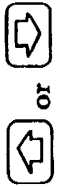
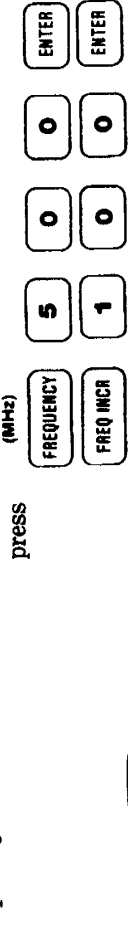

or steps the frequency up or down by the 100 MHz increment set with the FREQ INCR key.

STORE AND RECALL

Table 3-1. Operating Characteristics

Measurements	Noise Figure (Corrected and Uncorrected Modes) Range: 0 to 30 dB Selectable Display Units: F dB, F, Y dB, Y, Te K Insertion Gain (Corrected Mode Only) Range: -20 to +40 dB Display Units: dB
Tuning	Fixed Frequency Range 10 to 1600 MHz (Noise Figure Meter) 10 to 26500 MHz (Noise Figure Measurement System) Sweep Linear sweep Range: 10 to 1600 MHz Resolution: 1 MHz Modes: Automatic, Single
Noise Source Parameters	Drive: +28V (pulsed) Entry Units: ENR in dB, °C, °F, K Hot Temp. Entry Range: 363 to 1500K Cold Temp. Entry Range: 0 to 1000K
Smoothing	Exponential or linear averaging of insertion gain and noise figure data before result is displayed. Selectable units in factors of 2.

of the
measure-
ments
(see Figure
3-2).

ry (see Figure



NOISE FIGURE displays measured noise (in selectable output units), error codes and ENR table number with number of table entries. Other displays are possible when using Special Functions (see Figure 3-2).

GRAPHIC SCALE keys set the vertical scaling for an oscilloscope or plotter (see Figure 3-3).

CALIBRATE key initiates a calibration sequence. This sequence measures the noise figure of the measurement system for use in corrected measurements (see Figure 3-7).

CORRECTED NOISE FIGURE AND GAIN key selects the noise figure and gain measurement. The measurement system noise contribution is automatically removed (see Figure 3-7).

INPUT couples the output signal from the measurement setup into the Noise Figure Meter (see Figure 3-7).

is entry of
-6).

UNCORRECTED NOISE FIGURE key selects the noise figure measurement. Displayed values include noise contribution of all parts of the measurement system (see Figure 3-7).

SMOOTHING keys INCREASE or DECREASE the amount of smoothing (see Figure 3-7).

SIMPLIFIED OPERATION

PRESET

Press **PRESET** This sets the front panel functions to the following:

FREQUENCY = 30 MHz	STEP SIZE = 20 MHz
FREQ INCR = 20 MHz	SMOOTHING = 1
START FREQ = 10 MHz	MEASUREMENT = UNCORRECTED NOISE FIGURE
STOP FREQ = 1600 MHz	CALIBRATE = Off
SWEEP = Off	

In addition, default values are entered for some Special Functions. Refer to Table 3-14, Special Function Summary.

MEASUREMENT MODES

The Noise Figure Meter has ten Measurement Modes (1.0 through 1.9). Mode 1.0 is used for RF Measurements ranging from 10 to 1600 MHz (2047 MHz, opt 020) and requires no external equipment (except a noise source). Modes 1.1 through 1.4 are used for microwave measurements up to 99999 Mhz and require the system local oscillator (LO). Modes 1.1 and 1.2 also require an external mixer (the mixer is part of the device-under-test (DUT) in modes 1.3 and 1.4). Modes 1.5 through 1.9 are also for microwave measurements. Mode 1.5 is used for measurements from 10 to 26500 MHz. Modes 1.6 through 1.9 are for measurements up to 99999 MHz. Modes 1.5 through 1.9 require use of the Noise Figure Test Set and the system LO. Along with the Noise Figure Meter, the Noise Figure Test Set and the system LO form the Noise Figure Measurement System, which extends the range of the Noise Figure Meter from 1600 MHz (2047 MHz, opt 020) to 26500 MHz. Modes 1.6 through 1.9 require use of a second LO (user-controlled). The user-controlled LO is used with the Noise Measurement System, and along with an external mixer, extend the range of the Noise Figure Measurement System from 26500 to 99999 MHz. Modes 1.6 and 1.7 require an external mixer (the mixer is part of the DUT in modes 1.8 and 1.9). Refer to the operating information pull-out card and Measurement Modes in the Detailed Operating Instructions for more information. A Measurement Mode must be selected before performing a calibration or measurement. (Mode 1.0 is selected with PRESET.) Simplified Operation assumes that Mode 1.0 is selected

FIXED FREQUENCY TUNING

Fixed frequency parameters are selected in a Function-Data-ENTER format. For example, to set the tuned frequency to 500 MHz and the frequency increment to 100 MHz:

press

	FIXED FREQ (MHz)			DATA		
FREQUENCY	5	0	0	ENTER		
FREQ INCR	1	0	0	ENTER		

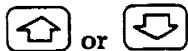

or



steps the frequency up or down by the 100 MHz increment set with the FREQ INCR key.

STORE AND RECALL

The Noise Figure Meter can store instrument configurations for recall at a later time. For example, to store an instrument configuration in storage register 5:

press **STORE** **5**

To recall the stored instrument configuration: press **RECALL** **5**

The Noise Figure Meter can store and recall four (1 through 4) Excess Noise Ratio (ENR) tables. For example, to store ENR data to table 3, use the following sequence:

press **STORE** **ENR** **3**

To recall ENR table 3, use the following sequence: press **RECALL** **ENR** **3**

SWEEP FUNCTIONS

Sweep parameters are selected in a Function-Data-ENTER format. For example, to set the start frequency to 1000 MHz, the stop frequency to 1600 MHz and the step size to 100 MHz:

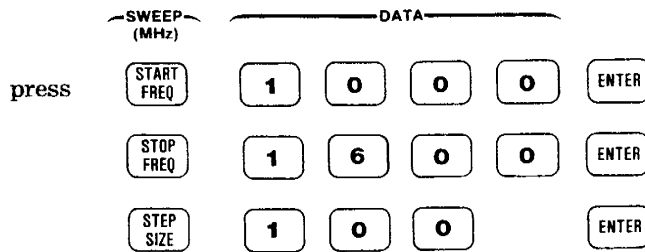

The Noise Figure Meter can sweep the selected frequency range once (SINGLE) or repetitively (AUTO). The sweep can be terminated by pressing the same key again.

MEASUREMENT

Connect a noise source to the Noise Figure Meter as shown:

Uncorrected Noise Figure

To measure uncorrected noise figure: press . The Noise Figure Meter is measuring its own noise figure.

● UNCORRECTED

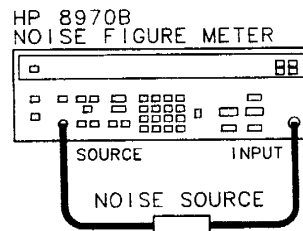

Calibrate

Calibrate measures and stores the measurement system noise characteristic at each frequency for correction of later measurements. Set START FREQ, STOP FREQ and STEP SIZE parameters. To initiate a calibration:

press twice

Corrected Noise Figure and Gain

The Noise Figure Meter must be calibrated before a corrected noise figure and gain measurement can be made.

After calibration, to measure corrected noise figure and gain: press .

● CORRECTED

Note that the Noise Figure Meter removes its own noise figure from the measurement results.

Smoothing

To change the number of measurements averaged to optimize speed of response and reduce jitter in the INSERTION GAIN and NOISE FIGURE displays: press or .

SPECIAL FUNCTIONS

Special Functions access capabilities of the Noise Figure Meter beyond those available with dedicated front panel keys. Special Functions are selected in a Code-SPECIAL FUNCTION format. For example, to display the ENR entry currently being used: press

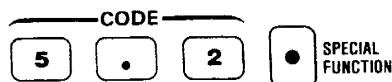

Refer to the Special Functions Detailed Operating Instruction at the end of this section for more information.

Table 3-2. Detailed Operating Instructions Table of Contents (Functional) (1 of 2)

Section	Page	Section	Page
Attenuation		Measurements	
IF Attenuation Selection	3-117	Manual Measurement Functions . . .	3-121
RF Attenuation Selection	3-222	Noise Figure (Uncorrected) and Noise Figure and Gain (Corrected)	3-198
Calibration		Power Measurements	3-200
Calibrate	3-59	Trigger Selection	3-273
Calibration, Frequency	3-65	Miscellaneous	
Calibration, IF Attenuators	3-67	Data Output to Oscilloscopes, Recorders and Plotters	3-73
Calibration, Input Gain Selection	3-69	Error Messages and Recovery	3-93
Noise Figure Test Set YIG Filter Calibration	3-190	Preset Conditions and Power Up Sequence	3-205
Displays		Sequence	3-224
Display Control	3-81	Store and Recall	3-257
Display Resolution	3-83	Programs	
Display Units Selection	3-85	Programming the System LO . . .	3-211.1
Smoothing (Averaging)	3-230	Programs Available to Control the System LO	3-219
Temperature Units Selection	3-271	Special Functions	
ENR		Calibration, Frequency	3-65
ENR Table Entry	3-87	Calibration, IF Attenuators	3-67
Loss Compensation	3-119	Calibration, Input Gain Selection . . .	3-69
Spot ENR, T_{hot} , T_{cold} and ENR Table Selection	3-254	Controller Capability of the Noise Figure Meter	3-71
Temperature Units Selection	3-271	Data Output to Oscilloscopes, Recorders and Plotters	3-73
HP-IB and SIB		Display Control	3-81
Controller Capability of the Noise Figure Meter	3-71	Display Resolution	3-83
HP-IB and System Interface Bus (SIB) Addresses	3-113	Display Units Selection	3-85
System Interface Bus Control	3-262	Fixed IF or LO Frequency Selection	3-110
Measurement Modes		HP-IB and System Interface Bus (SIB) Addresses	3-113
Fixed IF or LO Frequency Selection	3-110	IF Attenuation Selection	3-117
Loss Compensation	3-119	Loss Compensation	3-119
Measurement Modes	3-125	Manual Measurement Functions . . .	3-121
Measurement Mode 1.0	3-132	Measurement Mode 1.0	3-132
Measurement Mode 1.1	3-135	Measurement Mode 1.1	3-135
Measurement Mode 1.2	3-140	Measurement Mode 1.2	3-140
Measurement Mode 1.3	3-145	Measurement Mode 1.3	3-145
Measurement Mode 1.4	3-150	Measurement Mode 1.4	3-150
Measurement Mode 1.5	3-155	Measurement Mode 1.5	3-155
Measurement Mode 1.6	3-160	Measurement Mode 1.6	3-160
Measurement Mode 1.7	3-168		
Measurement Mode 1.8	3-176		
Measurement Mode 1.9	3-183		
Sideband Selection	3-226		

Table 3-2. Detailed Operating Instructions Table of Contents (Functional) (2 of 2)

Section	Page	Section	Page
Special Functions (cont'd)		Special Functions (cont'd)	
Measurement Mode 1.7	3-168	Sideband Selection	3-226
Measurement Mode 1.8	3-176	Smoothing (Averaging)	3-230
Measurement Mode 1.9	3-183	Special Function Catalog	3-233
Noise Figure Test Set YIG Filter		Special Functions	3-235
Calibration	3-190	Spot ENR, T_{hot} , T_{cold} , and ENR Table	
Power Measurements	3-200	Selection	3-254
Preset Conditions and Power Up		System Interface Bus Control	3-262
Sequence	3-205	Temperature Units Selection	3-271
Programming the System LO	3-211.1	Trigger Selection	3-273
Programs Available to Control the		Tuning	
System LO	3-219	Fixed Frequency Increment	3-105
RF Attenuation Selection	3-222	Fixed Frequency Tuning	3-108
Sequence	3-224	Sweep	3-258



1 **LOCAL Key.** Returns the Noise Figure Meter to local operation (front panel control) from remote HP-IB control provided that the instrument is not in Local Lockout.

2 **HP-IB Annunciators.** Display the HP-IB status. The REMOTE annunciator lights when the Noise Figure Meter is in the remote mode. The TALK annunciator lights when the Noise Figure Meter is addressed to talk or is in Talk Only mode. The LISTEN annunciator lights when the Noise Figure Meter is addressed to listen. The SRQ annunciator lights when the Noise Figure Meter is sending a Require Service message to the controller.

3 **Left Display.** Depending upon the selected functions, the following information is displayed:

Frequency parameters - always displayed in MHz: 1 MHz resolution; 10 to 1600 MHz (2047 MHz, opt 020) measurement range in Mode 1.0; 10 to 26500 MHz measurement range in Mode 1.5; up to 99999 MHz in Modes 1.1 through 1.4 and 1.6 through 1.9.
Special Function codes are displayed as they are entered

Spot ENR — displayed in dB.

Temperature of the noise source — displayed in °C, °F, or K.

Sequence order.

Smoothing factor.

All data as it is being entered (except ENR in the "ENR versus Frequency" tables).

EXT MIX (external mixer) annunciator — lights when Measurement Mode 1.1 through 1.4 or 1.6 through 1.9 is active.

4 **INSERTION GAIN Display.** Displays (in dB) the gain of the device under test (DUT) to two decimal places. This display also shows ENR in dB when entering the ENR tables.

5 **NOISE FIGURE Display.** Displays measured noise. Five annunciators (F dB, Y dB, F, Te K, and Y) indicate the noise figure display units. This display is also used for power measurements (displayed in dB), error codes and during ENR Table entry displays the ENR table number with entry number.

Figure 3-2. Display and Remote Features

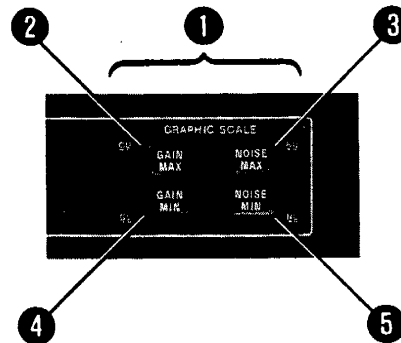

- 1 GRAPHIC SCALE.** The GRAPHIC SCALE keys are used to select the vertical scaling for an oscilloscope display or a plotter. The keys select the maximum and minimum limits for the display or plot. These keys perform the same functions as Special Functions 8.1 through 8.4.
- 2 GAIN MAX Key.** Used to display and enter the oscilloscope or plotter maximum vertical limit for insertion gain. When pressed the current GAIN MAX value appears in the left display. The allowable range of values for GAIN MAX is -9999 dB to 99999 dB. This key performs the same function as Special Function 8.4.
- 3 NOISE MAX Key.** Used to display and enter the oscilloscope or plotter maximum vertical limit for noise figure. When pressed the current NOISE MAX value appears in the left display. The allowable range of values for NOISE MAX is -9999 dB to 99999 dB. This key performs the same function as Special Function 8.2.
- 4 GAIN MIN Key.** Used to display and enter the oscilloscope or plotter minimum vertical limit for insertion gain. When pressed the current GAIN MIN value appears in the left display. The allowable range of values for GAIN MIN is -9999 dB to 99999 dB. This key performs the same function as Special Function 8.3.
- 5 NOISE MIN Key.** Used to display and enter the oscilloscope or plotter minimum vertical limit for noise figure. When pressed the current NOISE MIN value appears in the left display. The allowable range of values for NOISE MIN is -9999 dB to 99999 dB. This key performs the same function as Special Function 8.1.

Figure 3-3. GAIN MAX, GAIN MIN, NOISE MAX and NOISE MIN Features

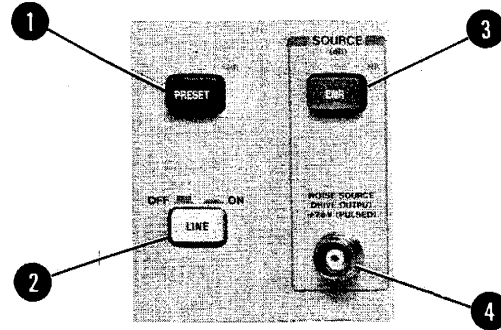

- 1 **PRESET Key.** Returns the instrument to a known state. Refer to the Preset Conditions and Power-Up Sequence Detailed Operating Instruction for a list of preset conditions and default values.
- 2 **LINE Switch.** Applies power to the Noise Figure Meter when set to the ON position.
- 3 **ENR Key.** Used to display and enable entry of the excess noise ratio (ENR) versus frequency tables. Five ENR tables, each table containing 35 frequencies, can be entered into the Noise Figure Meter. Frequency is shown in the left display and the corresponding ENR is shown in the INSERTION GAIN

display. The NOISE FIGURE display shows the ENR table number (0—4) and the current table entry number (1 through 35). An ENR table is selected by using the following sequence:

RECALL ENR N.

N is the number of the ENR table being recalled. An ENR table is stored using the following sequence:

STORE ENR N.

N is the number of the ENR table being stored.

- 4 **NOISE SOURCE DRIVE OUTPUT.** This BNC connector provides the output to drive a noise source on and off with +28 volt pulses.

Figure 3-4. LINE Switch, PRESET and SOURCE Features

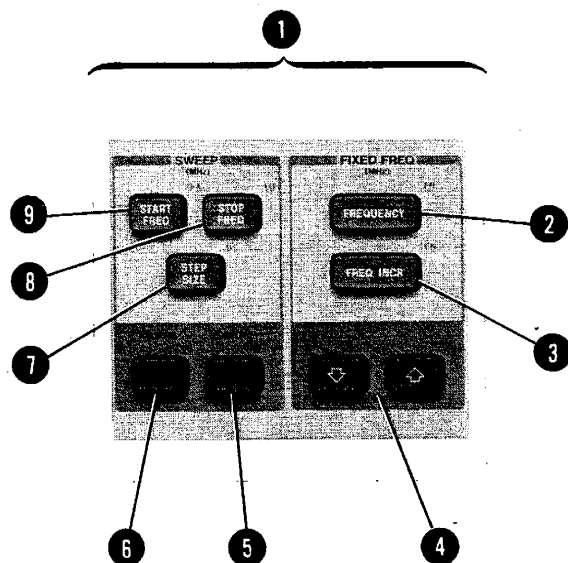

- 1 Frequency Function Keys.** In addition to the functions described below, the following keys are used to prefix numeric entries for the specified functions: START FREQ, STOP FREQ, STEP SIZE, FREQ, and FREQ INCR. Frequency is entered in MHz from the front panel. Frequency parameters are entered in a Function-Data-ENTER format.

FIXED FREQUENCY Keys

- 2 FREQUENCY Key.** Causes the tuned frequency to appear in the left display. This key also acts as a "clear" key when an error is made during entry; that is, it returns the instrument to the measurement frequency. (Also see Frequency Function Keys.)
- 3 FREQ INCR Key.** Causes the programmed frequency increment to appear in the left display while the key is depressed. (Also see Frequency Function Keys.)
- 4 \uparrow or \downarrow keys.** Increase or decrease the tuned fixed frequency by the programmed frequency increment. Holding either of these keys down causes the tuning to step continuously up or down.
- SWEEP Keys**
- 5 SINGLE Key.** Starts one sweep from START FREQ to STOP FREQ in increments determined by STEP SIZE.
- 6 AUTO Key.** Starts a sweep from the current frequency. The sweep repeats from START FREQ to STOP FREQ in increments determined by STEP SIZE until terminated. Auto sweep is terminated by pressing the AUTO key a second time.
- 7 STEP SIZE Key.** Causes the programmed frequency step size of the sweep to appear in the left display while the key is depressed. (Also see Frequency Function Keys.)
- 8 STOP FREQ Key.** Tunes the Noise Figure Meter to the programmed stop frequency and causes that frequency to appear in the left display. (Also see Frequency Function Keys.)
- 9 START FREQ Key.** Tunes the Noise Figure Meter to the programmed start frequency and causes that frequency to appear in the left display. (Also see Frequency Function Keys.)

At the end of one sweep the instrument remains tuned to the stop frequency. Single sweep can be terminated by pressing the SINGLE key a second time.

Figure 3-5. SWEEP and FIXED FREQ Features

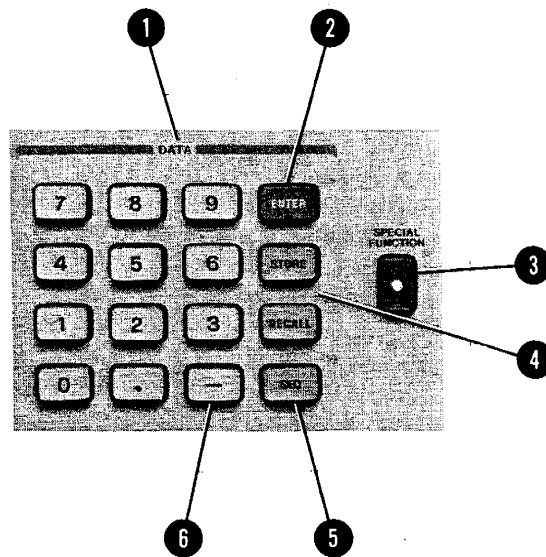

- 1 **DATA Keys.** Enter data or Special Function codes. Entries are completed by the ENTER key or the SPECIAL FUNCTION key (except for STORE and RECALL).
- 2 **ENTER Key.** Completes keyboard entries other than Special Function codes.
- 3 **SPECIAL FUNCTION Key.** Completes the keyboard entry of a Special Function code. Special Functions are instrument operations in addition to those accessible from dedicated front panel keys. Refer to Special Functions in the Detailed Operating Instructions for a complete listing of user special functions.
- 4 **STORE and RECALL Keys.** Store and recall up to ten instrument configurations in storage registers 0 through 9. Front panel features that cannot be stored and later recalled are CALIBRATE, SMOOTHING, AUTO or SINGLE SWEEP, UNCORRECTED NOISE FIGURE and CORRECTED NOISE FIGURE AND GAIN. STORE and RECALL are also used to store or recall an ENR table.

When the STORE key is used as a prefix for a numeric key (a single digit 0 — 9 to identify the register), the current instrument configuration is stored in that internal storage register.

When the RECALL key is used as a prefix to a numeric key (a single digit 0 — 9 to identify the register), the contents stored in that register are recalled and the instrument configuration is changed to the recalled parameter values.

- 5 **SEQ Key.** Recalls storage registers 1 through 9 in a preset sequence. Pressing the SEQ key momentarily displays the current storage register number. SEQ is used in conjunction with Special Function 35.
- 6 **- (Minus) Key.** Can be used as a prefix for loss, ENR, or temperature. Although the minus key can be used any time before an entry is completed, the minus sign is always inserted to the left of the entered digits. If the minus sign is used incorrectly an error message is displayed when ENTER is pressed.

Figure 3-6. DATA and SPECIAL FUNCTION Features

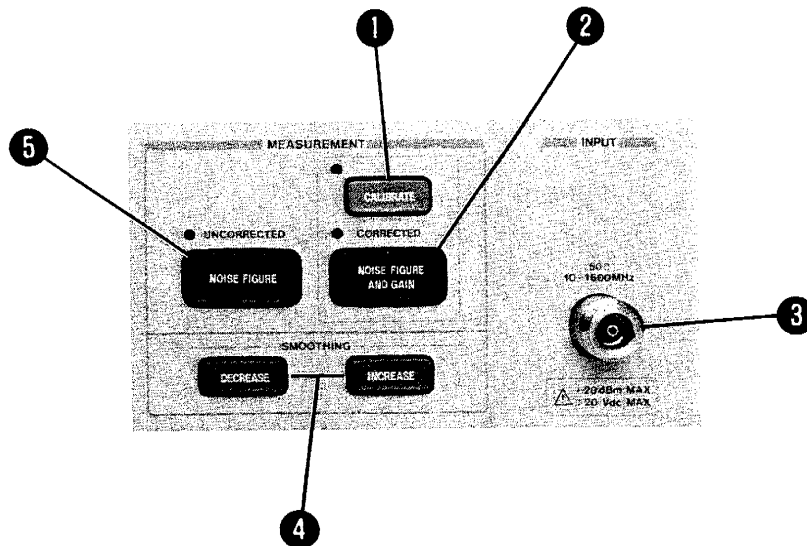

- 1 **CALIBRATE Key.** Initiates the calibration process which measures and stores the measurement system noise figure and gain. This data is used for second stage correction and gain measurements. Calibration is done from START FREQ to STOP FREQ in steps of STEP SIZE (see Figure 3-5). During calibration all front panel keys except PRESET, CALIBRATE and LOCAL are disabled. To start a calibration, the CALIBRATE key must be pressed twice. Pressing CALIBRATE before calibration is complete terminates the calibration.
- 2 **CORRECTED NOISE FIGURE AND GAIN Key.** Configures the Noise Figure Meter to measure noise figure and gain with second stage correction (that is, only the noise figure and gain of the device under test is displayed). A calibration must be completed prior to making corrected noise figure and gain measurements.
- 3 **INPUT.** This female type-N INPUT connector is used to connect the device under test to the Noise Figure Meter in Modes 1.0 through 1.4. In Modes 1.5 through 1.9, the Noise Figure Test Set is connected to this input. The nominal input impedance is 50 ohms. Specified operating input level is less than -10 dBm. The frequency range at the INPUT connector is 10 to 1600

MHz (2047 MHz, opt 020). The maximum average input power for a CW signal, and the maximum peak input power for a pulsed signal is +20 dBm (+13 dBm, opt 020).

CAUTION

Damage to the instrument can be caused by connecting signals to INPUT that exceed +20 dBm (+13 dBm, opt 020) or +20 Vdc.

- 4 **SMOOTHING Keys.** INCREASE and DECREASE the number of measurements averaged (smoothing factor) when displaying measurement results. When pressed, these keys cause the smoothing factor to appear in the left display. The smoothing factor ranges from 1 to 512 and changes in factors of 2. Pressing INCREASE doubles the smoothing factor. Pressing DECREASE halves the smoothing factor. Both INSERTION GAIN and NOISE FIGURE displays are smoothed. Increasing the smoothing reduces the jitter in the display.
- 5 **UNCORRECTED NOISE FIGURE Key.** Configures the Noise Figure Meter to measure noise figure without second stage correction (that is, the noise contribution of the measurement system is included in the reading in the NOISE FIGURE display).

Figure 3-7. MEASUREMENT and INPUT Features

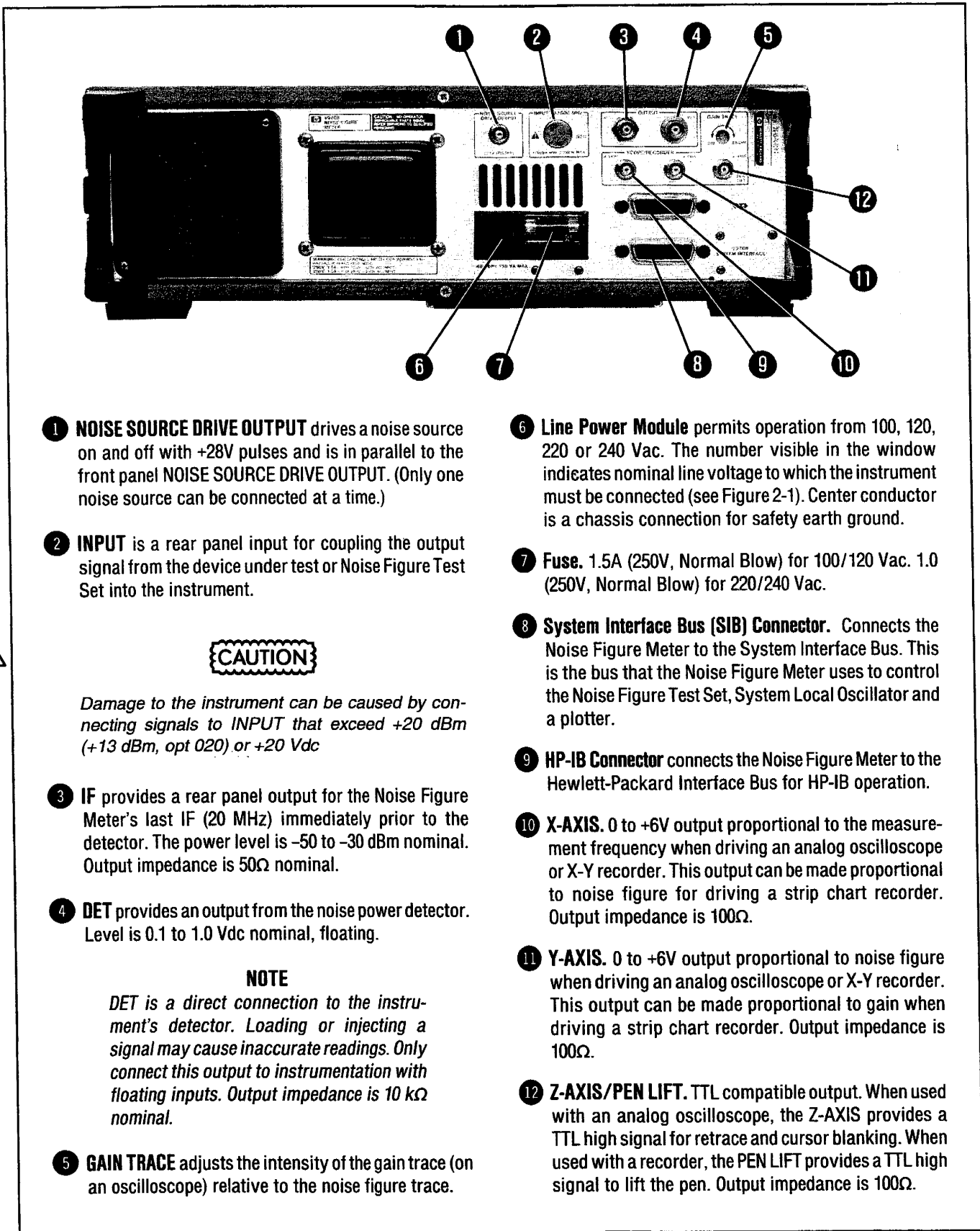

1 **NOISE SOURCE DRIVE OUTPUT** drives a noise source on and off with +28V pulses and is in parallel to the front panel NOISE SOURCE DRIVE OUTPUT. (Only one noise source can be connected at a time.)

2 **INPUT** is a rear panel input for coupling the output signal from the device under test or Noise Figure Test Set into the instrument.



CAUTION

Damage to the instrument can be caused by connecting signals to INPUT that exceed +20 dBm (+13 dBm, opt 020) or +20 Vdc

3 **IF** provides a rear panel output for the Noise Figure Meter's last IF (20 MHz) immediately prior to the detector. The power level is -50 to -30 dBm nominal. Output impedance is 50Ω nominal.

4 **DET** provides an output from the noise power detector. Level is 0.1 to 1.0 Vdc nominal, floating.

NOTE

DET is a direct connection to the instrument's detector. Loading or injecting a signal may cause inaccurate readings. Only connect this output to instrumentation with floating inputs. Output impedance is 10 kΩ nominal.

5 **GAIN TRACE** adjusts the intensity of the gain trace (on an oscilloscope) relative to the noise figure trace.

6 **Line Power Module** permits operation from 100, 120, 220 or 240 Vac. The number visible in the window indicates nominal line voltage to which the instrument must be connected (see Figure 2-1). Center conductor is a chassis connection for safety earth ground.

7 **Fuse.** 1.5A (250V, Normal Blow) for 100/120 Vac. 1.0 (250V, Normal Blow) for 220/240 Vac.

8 **System Interface Bus (SIB) Connector.** Connects the Noise Figure Meter to the System Interface Bus. This is the bus that the Noise Figure Meter uses to control the Noise Figure Test Set, System Local Oscillator and a plotter.

9 **HP-IB Connector** connects the Noise Figure Meter to the Hewlett-Packard Interface Bus for HP-IB operation.

10 **X-AXIS.** 0 to +6V output proportional to the measurement frequency when driving an analog oscilloscope or X-Y recorder. This output can be made proportional to noise figure for driving a strip chart recorder. Output impedance is 100Ω.

11 **Y-AXIS.** 0 to +6V output proportional to noise figure when driving an analog oscilloscope or X-Y recorder. This output can be made proportional to gain when driving a strip chart recorder. Output impedance is 100Ω.

12 **Z-AXIS/PEN LIFT.** TTL compatible output. When used with an analog oscilloscope, the Z-AXIS provides a TTL high signal for retrace and cursor blanking. When used with a recorder, the PEN LIFT provides a TTL high signal to lift the pen. Output impedance is 100Ω.

Figure 3-8. Rear Panel Features

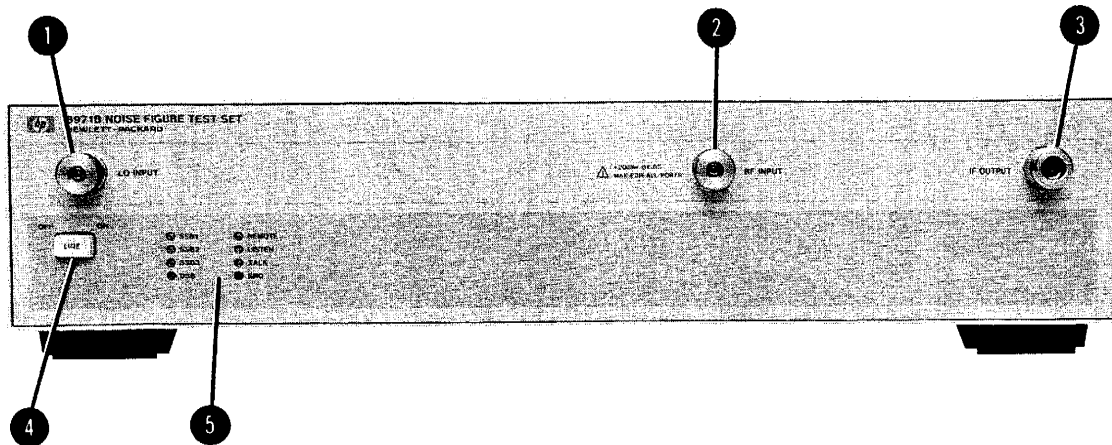

- 1 LO INPUT Connector connects the signal from a local oscillator to the Test Set for RF input signals above 1600 MHz.
- 2 RF INPUT Connector connects the signal from the measurement setup into the Test Set. If the input signal is 1600 MHz or below, it is connected by internal relays directly to the IF OUTPUT connector, to go to the Noise Figure Meter. Otherwise, it is mixed with the local oscillator input (LO INPUT) and the IF

signal generated is routed to the IF OUTPUT connector.

- 3 IF OUTPUT Connector connects the output of the Test Set to the Noise Figure Meter.
- 4 LINE Switch applies power to the instrument when set to ON.
- 5 ANNUNCIATORS indicate the configuration selected and the status of the HP-IB bus (also called the System Interface Bus).

Figure 3-9. HP 8971B/C Front Panel Features

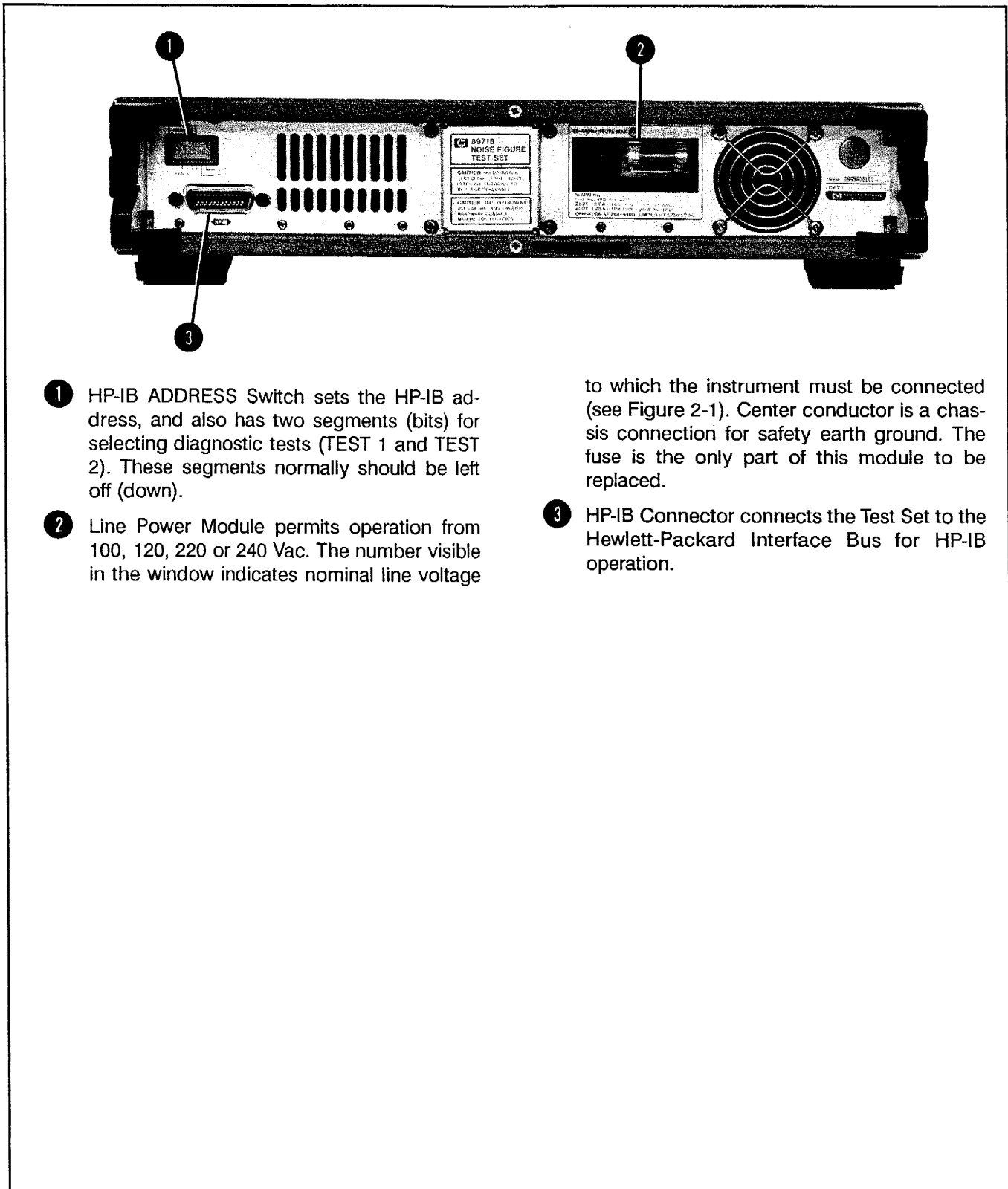

- 1 HP-IB ADDRESS Switch sets the HP-IB address, and also has two segments (bits) for selecting diagnostic tests (TEST 1 and TEST 2). These segments normally should be left off (down).
- 2 Line Power Module permits operation from 100, 120, 220 or 240 Vac. The number visible in the window indicates nominal line voltage

to which the instrument must be connected (see Figure 2-1). Center conductor is a chassis connection for safety earth ground. The fuse is the only part of this module to be replaced.

- 3 HP-IB Connector connects the Test Set to the Hewlett-Packard Interface Bus for HP-IB operation.

Figure 3-10. HP 8971B/C Rear Panel Features

OPERATOR'S CHECKS

3-10. OPERATOR'S CHECKS

3-11. Basic Functional Checks

Description The overall operation of the Noise Figure Meter is checked using a noise source and an analog display module. If the Noise Figure Meter is to be used to control the System LO, the optional System LO Check at the end of this procedure verifies that capability. This check should be performed sequentially.

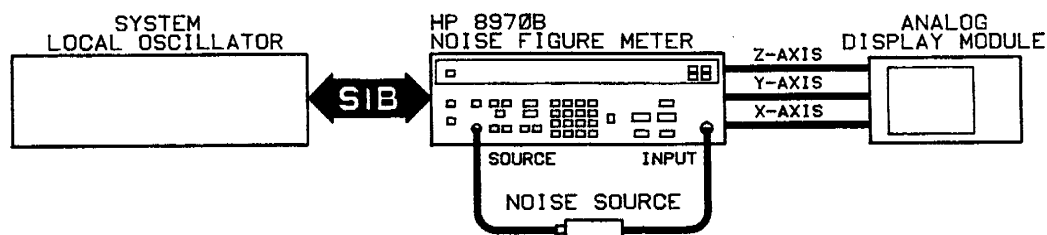

Figure 3-11. Basic Functional Checks Setup

Equipment	Noise Source	HP 346B Option 001
	Analog Display Module	HP 1332A Options 101 and 315
	System LO	HP 8671B

Procedure

Preliminary Check

1. Remove any cables from the Noise Figure Meter's INPUT and SOURCE. Set the LINE switch to OFF, and then back to ON. Verify the front panel LED annunciators, display segments, decimal points, and key lights turn on for approximately two seconds. Then, verify that "Ctrl" appears in the INSERTION GAIN display and "on" or "OFF" appears in the NOISE FIGURE display. If the Noise Figure Meter is the system controller on the System Interface Bus (Special Function 48.0) "on" will be displayed. If the Noise Figure Meter is not the system controller on the System Interface Bus (Special Function 48.1) "OFF" will be displayed. Then, "Fr" will appear in the INSERTION GAIN display and "CAL" will appear in the NOISE FIGURE display for approximately five seconds while the Noise Figure Meter performs a frequency calibration.
2. Press PRESET. After "Fr" disappears from the INSERTION GAIN display and "CAL" disappears from the NOISE FIGURE display, verify the following conditions:

NOTE

If error code E44 is displayed, press 45.0 SPECIAL FUNCTION. Since Measurement Mode 1.0 (default after PRESET) doesn't require the Noise Figure Test Set, Special Function 45.0 disables Noise Figure Test Set commands in Measurement Mode 1.0.

- a. Left display shows 30 MHz.
- b. INSERTION GAIN display is blank.
- c. NOISE FIGURE display shows "— FdB".
- d. UNCORRECTED NOISE FIGURE annunciator is on.

OPERATOR'S CHECKS

Basic Functional Checks (cont'd)**Procedure (cont'd)**

3. Enter the Excess Noise Ratio (ENR) data for the noise source being used. For more information, refer to the ENR Table Entry Detailed Operating Instruction. Connect the noise source between the Noise Figure Meter's SOURCE and INPUT (see Figure 3-11). Verify the NOISE FIGURE display shows approximately 5 dB.
4. Connect the display to the X-, Y-, and Z-AXIS connectors on the rear panel of the Noise Figure Meter. Use the X-AXIS for the horizontal input and the Y-AXIS for the vertical input.
5. On the Noise Figure Meter, press 7.1 SPECIAL FUNCTION. Verify that a test pattern is seen on the display. It may be necessary to adjust rear panel GAIN TRACE control to obtain the test pattern. The test pattern should be 6 ± 0.5 volts vertically and horizontally. Adjust the display until the test pattern fills the grid area (see Figure 3-12). Press 7.0 SPECIAL FUNCTION to enable the Noise Figure Meter to output the noise figure and gain data to the display.

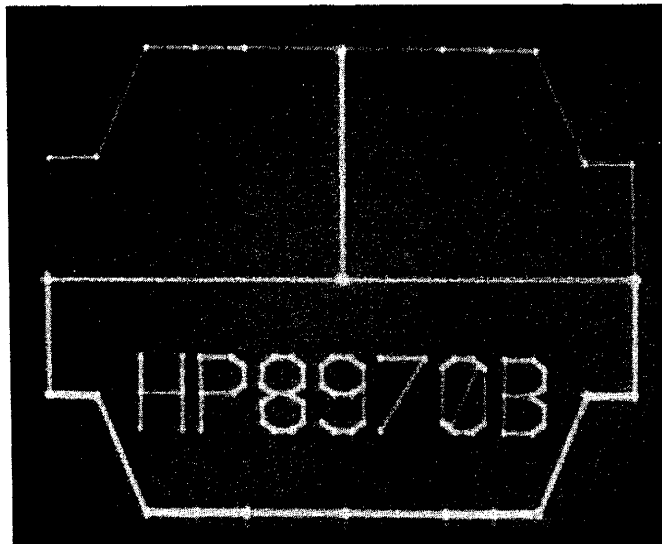

Figure 3-12. Test Pattern on Oscilloscope

Calibration and SWEEP Check

6. Press CORRECTED NOISE FIGURE AND GAIN. Verify the NOISE FIGURE display shows an error message.

NOTE

In step 6, error code E20 (not calibrated) is normally displayed.

7. Press UNCORRECTED NOISE FIGURE. Verify that the NOISE FIGURE display shows approximately 5 FdB indicating that the Noise Figure Meter can make uncorrected noise figure measurements prior to being calibrated.
8. Press CORRECTED NOISE FIGURE AND GAIN. Verify the NOISE FIGURE display again shows an error message.

OPERATOR'S CHECKS

Basic Functional Checks (cont'd)**Procedure
(cont'd)****NOTE**

All frequency data must be entered in MHz.

9. Press the following keys to enter the SWEEP calibration parameters:
 - a. START FREQ 1 2 3 ENTER.
 - b. STOP FREQ 7 8 9 ENTER.
 - c. STEP SIZE 4 0 ENTER.
10. Press CALIBRATE twice. Verify the following conditions:
 - a. CALIBRATE annunciator lights.
 - b. The frequency is swept from the start frequency (123 MHz) to the stop frequency (789 MHz) in 40 MHz steps. This sweep is performed three times.
 - c. After calibration is complete, the CALIBRATE annunciator turns off and the CORRECTED NOISE FIGURE AND GAIN annunciator lights.
 - d. The INSERTION GAIN display shows approximately 0 dB and the NOISE FIGURE display shows approximately 0 FdB.
11. Press SWEEP SINGLE. Verify that the key's LED lights. The established frequency range is swept once. After the sweep is completed, the LED turns off and the left display shows 789 MHz.
12. Press SWEEP AUTO. Verify that the key's LED lights and the frequency range is swept repetitively. Press SWEEP AUTO again. Verify the sweep stops at the current frequency and the LED goes off.
13. Press SMOOTHING INCREASE four times to set the smoothing (averaging) factor to 16. Press SWEEP SINGLE. Verify that the INSERTION GAIN and NOISE FIGURE displays are more stable and the time required for each measurement is longer. Press SMOOTHING DECREASE four times to return the smoothing factor to 1.

GRAPHIC SCALE Check



14. Verify that the display is set up as described in steps 3 through 5.
 15. Press 7.0 SPECIAL FUNCTION. This will enable Noise Figure and Insertion Gain to be seen on the display.
 16. Press NOISE MAX. Verify that 8.000 dB is shown in the left display. If 8.000 dB is not shown, press 8 and ENTER.
 17. Press NOISE MIN. Verify that 0.000 dB is shown in the left display. If 0.000 dB is not shown, press 0 and ENTER.
 18. Press GAIN MAX. Verify that 40.00 dB is shown in the left display. If 40.00 dB is not shown, press 40 and ENTER.
-

OPERATOR'S CHECKS

Basic Functional Checks (cont'd)**Procedure
(cont'd)**

19. Press GAIN MIN. Verify that 0.000 dB is shown in the left display. If 0.000 dB is not shown, press 0 and ENTER.
20. Press START FREQ. Verify that 10 is displayed in the left display. If 10 is not displayed, key in 10 and press ENTER. Press STOP FREQ. Verify that 1600 is displayed in the left display. If 1600 is not displayed, key in 1600 and press ENTER. Press STEP SIZE. Verify that 20 is displayed in the left display. If 20 is not displayed, key in 20 and press ENTER.
21. Press CALIBRATE twice. The Noise Figure Meter will perform a calibration from the start frequency to the stop frequency, using the step size selected.
22. Press CORRECTED NOISE FIGURE AND GAIN.
23. Press SINGLE SWEEP. Verify that the traces are along the bottom of the display.
24. Change the NOISE MAX and GAIN MAX limit to 2. Change the NOISE MIN and GAIN MIN limit to -2.
25. Press SINGLE SWEEP. The Noise Figure trace and Insertion Gain trace will appear in the center of the display.

FIXED FREQUENCY Tuning Check

26. Press the following keys to establish the tuned FIXED FREQUENCY parameters:
 - a. FREQUENCY 5 0 0 ENTER.
 - b. FREQ INCR 3 0 0 ENTER.
27. Press . Verify that the left display shows 800 MHz and the NOISE FIGURE display shows error code E21 (current frequency is out of calibrated range).
28. Press . Verify the left display shows 500 MHz and the INSERTION GAIN and NOISE FIGURE displays show approximately 0.

ENR Table Entry Check**NOTE**

This check verifies the capability of the ENR and ENTER keys to initiate and sequence through the ENR table. If it is necessary to change the ENR table, refer to the ENR Table Entry Detailed Operating Instruction.

29. Press ENR. Verify the MHz annunciator in the left display is flashing.
 30. Press ENTER. Verify that the MHz annunciator remains on and the dB annunciator in the INSERTION GAIN display is flashing.
 31. Press and hold ENTER. Verify the two displays sequence through the ENR table entries. Also, the ENR table entry should be changing in the NOISE FIGURE display. Release ENTER.
-

OPERATOR'S CHECKS

Basic Functional Checks (cont'd)**Procedure
(cont'd)****NOTE**

If ENTER is held down until all 35 frequency vs. ENR pairs have been displayed, both annunciators light and remain lit. When ENTER is released, the Noise Figure Meter returns to the measurement configuration it was in prior to pressing ENR. If ENTER is released prior to displaying all pairs, press FREQUENCY to return to the previous measurement configuration.

32. Verify that the CORRECTED NOISE FIGURE AND GAIN annunciator lights.

STORE, RECALL and SEQ Check

33. Press PRESET. Verify the left display shows 30 MHz.

NOTE

During the STORE and RECALL checks the complete instrument configuration is stored and recalled. The frequency change is merely a convenient indication that different setups have been stored and recalled.

34. Press STORE 1.
35. Press . Verify the left display shows 50 MHz. Press STORE 2.
36. Press RECALL 1. Verify the left display shows 30 MHz. Press RECALL 2. Verify the left display shows 50 MHz.
37. Press and hold SEQ. Verify the left display shows 1. Release SEQ. Verify the left display shows 30 MHz.
38. Press and hold SEQ. Verify the left display shows 2. Release SEQ. Verify the left display shows 50 MHz.

Minus Check

39. Press -. Verify the left display shows -.

System LO Check (Optional; for Measurement Modes 1.1 through 1.4)**NOTE**

The following steps check the Noise Figure Meter's capability to control the System LO. It is not necessary to perform this check unless the Noise Figure Meter is used for this purpose and a suitable System LO is available. It is assumed in the following check that the SIB addresses used by the Noise Figure Meter and the System LO are compatible.

40. Connect the System LO to the Noise Figure Meter's SYSTEM INTERFACE BUS connector (see Figure 3-9).
41. Press 48.0 SPECIAL FUNCTION. This will enable the Noise Figure Meter to be the system controller on the System Interface Bus.
-

OPERATOR'S CHECKS

Basic Functional Checks (cont'd)**Procedure
(cont'd)**

42. Press 46.0 SPECIAL FUNCTION. This will enable the commands for the system LO on the System Interface Bus.
43. Press one of the following sequences of keys depending upon the System LO used:
 - a. For an HP 8350B, press 41.0 SPECIAL FUNCTION.
 - b. For an HP 8671B/8672A press 41.2 SPECIAL FUNCTION.
 - c. For an HP 8673B/C/G, press 41.3 SPECIAL FUNCTION.
 - d. For an HP 8340B/8341B, press 41.4 SPECIAL FUNCTION.
 - e. For the Custom Local Oscillator Program, press 41.5 SPECIAL FUNCTION.
44. Press 1.1 SPECIAL FUNCTION. Verify the left display shows 10000 MHz and the EXT MIX annunciator lights. Also, verify that the remote and listen annunciators light on the system LO.
45. On the Noise Figure Meter, press SWEEP START FREQ. Verify the left display shows 8000 MHz and the System LO is tuned to the same frequency.
46. On the Noise Figure Meter, press SWEEP STOP FREQ. Verify the left display shows 12000 MHz and the System LO is tuned to the same frequency.

OPERATOR'S CHECKS

3-12. HP-IB Functional Checks **HP-IB**

Description

The following procedures check the instrument's ability to perform the following functions:

- a. Process or send all of the applicable HP-IB messages described in Table 3-3.
- b. Recognize its own HP-IB address.
- c. Set all of the bus data, handshake, and control lines (except DIO8) to both their true and false states.

These procedures do not check if all Noise Figure Meter program codes are being properly interpreted and executed by the instrument. However, if the power-up sequence (including the memory checks) and the front panel operation is good, the program codes, in all likelihood, will be correctly executed.

The validity of these checks is based on the following assumptions:

- a. The Noise Figure Meter performs properly when operated via the front panel keys (that is, in local mode). This can be verified with the Basic Functional Checks.
- b. The bus controller properly executes HP-IB operations.
- c. The bus controller's HP-IB interface properly executes the HP-IB operations.

If the Noise Figure Meter appears to fail any of these HP-IB checks, the validity of the above assumptions should be confirmed before attempting to service the instrument.

The select code of the controller's HP-IB interface is assumed to be 7. The address of the Noise Figure Meter is assumed to be 8 (its address as set at the factory). This select code address combination (that is, 708) is not necessary for these checks to be valid. However, the program lines presented here have to be modified for any other combination.

These checks are intended to be as independent of each other as possible. Nevertheless, the first four checks should be performed in order before other checks are selected. Any special initialization or requirements for a check are described at its beginning.

Initial Setup

The test setup is the same for all of the checks. Connect the Noise Figure Meter to the bus controller via the HP-IB interface. Do not connect any equipment, other than the noise source, to the Noise Figure Meter's INPUT.

Equipment

HP-IB Controller	HP 9000 Series 200/300
Noise Source	HP 346B (Option 001)

OPERATOR'S CHECKS

HP-IB Functional Checks **HP-IB** (cont'd)

Address Recognition
Note

This check determines if the Noise Figure Meter recognizes when it is being addressed and when it is not. This check assumes only that the Noise Figure Meter can properly handshake on the bus. Before beginning this check, set the Noise Figure Meter's LINE switch to ON, press PRESET, 45.0 SPECIAL FUNCTION, and 4.0 SPECIAL FUNCTION.

Description	HP 9000 Series 200/300 (BASIC)
Set the Remote Enable (REN) bus control line false.	LOCAL 7
Send the Noise Figure Meter's listen address.	OUTPUT 708

Operator's Response

Check that the Noise Figure Meter's REMOTE annunciator is off and that its LISTEN annunciator is on.

Unaddress the Noise Figure Meter by sending a different address.	OUTPUT 715
--	------------

Operator's Response

Check that both the Noise Figure Meter's REMOTE and LISTEN annunciators are off.

Remote and Local Messages and the LOCAL Key
Note

This check determines if the Noise Figure Meter properly switches from local to remote control, from remote to local control, and if the LOCAL key returns the instrument to local control. This check assumes that the Noise Figure Meter is able to both handshake and recognize its own address. Before beginning this check, press the Noise Figure Meter's PRESET key. Then press 4.0 SPECIAL FUNCTION.

Description	HP 9000 Series 200/300 (BASIC)
Send the Remote message (by setting Remote Enable, REN, true and addressing the Noise Figure Meter to listen).	REMOTE 708

Operator's Response

Check that the Noise Figure Meter's REMOTE and LISTEN annunciators are on.

Send the Local message to the Noise Figure Meter	LOCAL 708
--	-----------

Operator's Response

Check that the Noise Figure Meter's REMOTE annunciator is off but its LISTEN annunciator is on.

Send the Remote message to the Noise Figure Meter.	REMOTE 708
--	------------

OPERATOR'S CHECKS

HP-IB Functional Checks **HP-IB (cont'd)**

Operator's Response

Check that both the Noise Figure Meter's REMOTE and LISTEN annunciators are on. Press the LOCAL key on the Noise Figure Meter. Check that the Noise Figure Meter's REMOTE annunciator is now off, but that its LISTEN annunciator remains on.

Sending the Data Message

Note

This check determines if the Noise Figure Meter properly issues Data messages when addressed to talk. This check assumes that the Noise Figure Meter is able to handshake and recognize its own address. Before beginning this check, press the Noise Figure Meter's LINE switch twice (OFF then ON). Then, after the power-up sequence is completed, press CORRECTED NOISE FIGURE AND GAIN and 4.0 SPECIAL FUNCTION. (If an HP 9000 Series 200/300 controller is used, a short program is required to perform this check.)

Description	HP 9000 Series 200/300 (BASIC)
Address the Noise Figure Meter to talk and store its output in variable V. (The output is E20 since the Noise Figure Meter is not calibrated.)	10 V = 0 20 ENTER 708;V 30 DISP V 40 END
Display the value of V.	DISP V

Operator's Response

Check that the Noise Figure Meter's REMOTE annunciator is off but that its TALK annunciator is on. The controller's display should read 9.002E+10 (HP 9000 Series 200/300).

Receiving the Data Message

Note

This check determines if the Noise Figure Meter properly receives Data messages. The Data messages sent cause the 7 least significant HP-IB data lines to be placed in both their true and false states. This check assumes the Noise Figure Meter is able to handshake, recognize its own address and properly make the remote/local transitions. Before beginning this check, press the Noise Figure Meter's PRESET key. Then press 4.0 SPECIAL FUNCTION.

Description	HP 9000 Series 200/300 (BASIC)
Send the first part of the Remote message (enabling the Noise Figure Meter to remote).	REMOTE 7
Address the Noise Figure Meter to listen (completing the Remote message), then send a Data message.	OUTPUT 708; "FR15MZ"

OPERATOR'S CHECKS

HP-IB Functional Checks  (cont'd)

Operator's Response Check that both the Noise Figure Meter's REMOTE and LISTEN annunciators are on and that the left display shows 15 MHz.

Local Lockout and Clear Lockout/Set Local Messages

Note This check determines if the Noise Figure Meter properly receives the Local Lockout message, disabling the LOCAL key. The check also determines if the Clear Lockout/Set Local message is properly received and executed by the Noise Figure Meter. This check assumes that the Noise Figure Meter is able to handshake, recognize its own address, and properly make the remote/local transitions. Before beginning this check, press the Noise Figure Meter's LINE switch OFF then ON and then press the PRESET key. Then press 4.0 SPECIAL FUNCTION.

Description	HP 9000 Series 200/300 (BASIC)
Send the first part of the Remote message (enabling the Noise Figure Meter to remote).	REMOTE 7
Send the Local Lockout message.	LOCAL LOCKOUT 7
Address the Noise Figure Meter to listen (completing the Remote message).	OUTPUT 708

Operator's Response Check that both the Noise Figure Meter's REMOTE and LISTEN annunciators are on. Press the Noise Figure Meter's LOCAL key. Both its REMOTE and LISTEN annunciators should remain on.

Send the Clear Lockout/Set Local message.	LOCAL 7
---	---------

Operator's Response Check that the Noise Figure Meter's REMOTE annunciator is off but its LISTEN annunciator is on.

Clear Message

Note This check determines if the Noise Figure Meter properly responds to the Clear message. This check assumes that the Noise Figure Meter is able to handshake, recognize its own address, make the remote/local changes and receive Data messages. Before beginning this check press the Noise Figure Meter's PRESET key. When "Fr" disappears from the INSERTION GAIN display and "CAL" disappears from the NOISE FIGURE display, press CALIBRATE twice. Once the LED above the CALIBRATE key turns off, press 4.0 SPECIAL FUNCTION.

OPERATOR'S CHECKS

HP-IB Functional Checks **HP-IB (cont'd)**

Description	HP 9000 Series 200/300 (BASIC)
Send the first part of the Remote message (enabling the Noise Figure Meter to remote).	REMOTE 7
Address the Noise Figure Meter to listen (completing the Remote message), then send a Data message that selects the CORRECTED NOISE FIGURE AND GAIN measurement.	OUTPUT 708; "M2"

Operator's Response

Check that both the Noise Figure Meter's REMOTE and LISTEN annunciators are on and that the CORRECTED NOISE FIGURE AND GAIN key light is on.

Send the Clear message (setting the Noise Figure Meters measurement to UNCORRECTED NOISE FIGURE).	CLEAR 708
---	-----------

Operator's Response

Check that both the Noise Figure Meter's REMOTE and LISTEN annunciators are on and that the UNCORRECTED NOISE FIGURE key light is on.

Abort Message Note

This check determines if the Noise Figure Meter becomes unaddressed when it receives the Abort message. Before beginning this check, enter LOCAL 708 and press the Noise Figure Meter's PRESET key. Then press 4.0 SPECIAL FUNCTION.

Description	HP 9000 Series 200/300 (BASIC)
Send the Remote message to the Noise Figure Meter.	REMOTE 708

Operator's Response

Check that both the Noise Figure Meter's REMOTE and LISTEN annunciators are on.

Send the Abort message, unaddressing the Noise Figure Meter from listening.	ABORT 7
---	---------

Operator's Response

Check that the Noise Figure Meter's LISTEN annunciator is off.

OPERATOR'S CHECKS

HP-IB Functional Checks **HP-IB** (cont'd)

Status Byte Message

Note

This check determines if the Noise Figure Meter sends the Status Byte message. Before beginning this check, press the Noise Figure Meter's PRESET key. Then press 4.0 SPECIAL FUNCTION.

Description	HP 9000 Series 200/300 (BASIC)
Place the Noise Figure Meter in serial-poll mode and address it to talk (causing it to send the Status Byte message).	SPOLL(708)

Operator's Response

Check that the controller's display reads 0.

Require Service Message

Note

This check determines if the Noise Figure Meter can issue the Require Service message (set the SRQ bus control line true). This check assumes that the Noise Figure Meter is able to handshake, recognize its own address, make the remote/local changes, and receive Data messages. Before beginning this check, press the Noise Figure Meter's PRESET key. Then press 4.0 SPECIAL FUNCTION. (If an HP 9000 Series 200/300 controller is used, a short program is required to perform the last half of this check.)

Description	HP 9000 Series 200/300 (BASIC)
Send the first part of the Remote message (enabling the Noise Figure Meter to remote).	REMOTE 7
Address the Noise Figure Meter to listen (completing the Remote message), then send a Data message containing an invalid HP-IB code. This enables a Require Service message to be sent.	OUTPUT 708; "<"
Make controller wait two seconds to allow time for the Noise Figure Meter to send the Require Service message. (This step is not necessary if sufficient time is allowed.)	WAIT
Read the binary status of the controller's HP-IB interface and store the data in variable V (in this step, 7 is the interface's select code).	10 V = 0 20 STATUS 7,7; V
Display the value of the SRQ bit (in this step 10 (HP 9836) is the SRQ bit for the controller, numbered from 0).	30 DISP "SRQ="; 30 BIT(V,10) 40 END

Operator's Response

Check that the SRQ value is 1, indicating the Noise Figure Meter issued the Require Service message.

OPERATOR'S CHECKS

HP-IB Functional Checks **HP-IB** (cont'd)**Trigger Message****Note**

This check determines if the Noise Figure Meter responds to the Trigger message. This check assumes that the Noise Figure Meter is able to handshake, recognize its own address, make the remote/local changes, and send and receive Data messages. Before beginning this check, enter LOCAL 708 and press the Noise Figure Meter's PRESET key. Then press 4.0 SPECIAL FUNCTION (If an HP 9000 Series 200/300 controller is used, a short program is required to perform this check.)

Description	HP 9000 Series 200/300 (BASIC)
Send the first part of the Remote message (enabling the Noise Figure Meter to remote).	10 REMOTE 7
Address the Noise Figure Meter to listen (completing the Remote message), then send a Data message placing the Noise Figure Meter in the Trigger Hold mode.	20 OUTPUT 708; "T1"
Send the Trigger message.	30 TRIGGER 708 40 V = 0
Address the Noise Figure Meter to talk and store the data in variable V.	50 ENTER 708; V
Display the value of V.	60 DISP V 70 END

OPERATOR'S CHECKS

3-13. Noise Figure Measurement System Check

Description This check will verify proper operation of the Noise Figure Measurement System (Noise Figure Meter, Noise Figure Test Set and System Local Oscillator). The Noise Figure Test Set and the System Local Oscillator extend the input frequency range of the Noise Figure Meter from 2047 to 26500 MHz.

Equipment Noise Source HP 346B Option 001

- Procedure**
1. Set up the Noise Figure Measurement System as shown in Figure 3-13.
 2. Turn the Noise Figure Measurement System on and press PRESET.
 3. Verify the following conditions:
 - Special Function 48.0 is active.
 - Special Function 45.1 is active.
 - Special Function 46.0 is active.
 - The address of the Noise Figure Test Set is the one stored in the Noise Figure Meter (Special Function 40.2).
 - The address of the System Local Oscillator is the one stored in the Noise Figure Meter (Special Function 40.1).
 - The appropriate System Local Oscillator program (Special Function 41) is active.

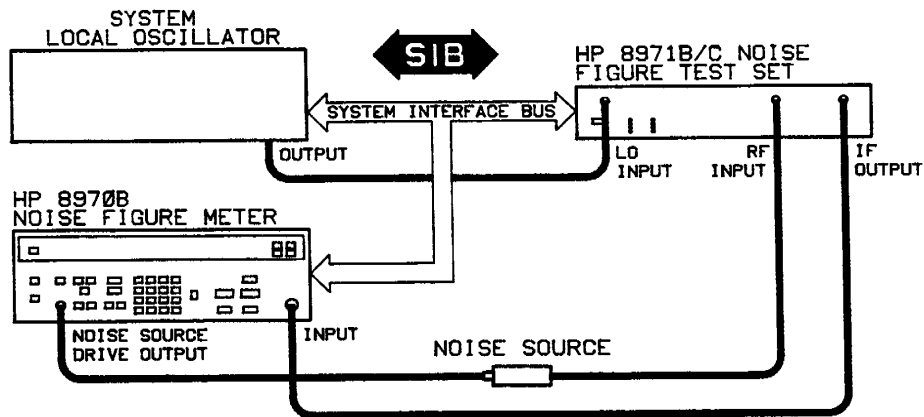

Figure 3-13. Noise Figure Measurement System Check Setup

OPERATOR'S CHECKS

Noise Figure Measurement System Check (cont'd)**Procedure
(cont'd)****NOTE**

Steps 4 through 9 will verify that the Noise Figure Test Set and the System Local Oscillator are properly connected to the Noise Figure Meter and that the Noise Figure Meter can talk to the Noise Figure Test Set and System Local Oscillator. If steps 4 through 9 do not perform as indicated, go to step 17.

4. On the Noise Figure Meter, press 1.5 SPECIAL FUNCTION. Verify that 3000 and E28 are displayed. Error code E28 can be ignored.
5. Press FREQUENCY and key in 100. Press ENTER. Verify that the SSB1 annunciator on the Noise Figure Test Set is on.
6. Press FREQUENCY and key in 2000. Press ENTER. Verify that the SSB2 annunciator on the Noise Figure Test Set is on and the LO is set to 2700 MHz.
7. Press FREQUENCY and key in 3000. Press ENTER. Verify that the SSB3 annunciator on the Noise Figure Test Set is on and the LO is set to 3450 MHz. Error code E28 will be displayed, on the Noise Figure Meter. This error can be ignored.
8. Press 17.1 SPECIAL FUNCTION. Verify that the DSB annunciator on the Noise Figure Test Set is on, the LO is set to 3000 MHz and E28 is gone.
9. Press 17.0 SPECIAL FUNCTION and 36.2 SPECIAL FUNCTION. Verify that error code E28 is still gone. Press 36.0 SPECIAL FUNCTION.
10. If steps 4 through 9 performed as indicated, go to step 12. If there seems to be a problem, go to step 11.
11. If any one of the steps (4 through 9) did not perform as indicated, check the cabling between the instruments. Then, repeat steps 4 through 9. If the problem still exists, go to step 17.

NOTE

The following steps will verify if the Noise Figure Measurement System is operating properly. If steps 12 through 16 do not perform as indicated, go to step 17.

12. On the Noise Figure Meter, change the start frequency to 1000, the stop frequency to 5000 and the step size to 1000. The procedure is to press the appropriate key (START FREQ, STOP FREQ or STEP SIZE), key in the new value and press ENTER.

NOTE

Step 13 should not be performed until the Noise Figure Measurement System has had a twenty minute warm-up period. Twenty minutes is needed for the Noise Figure Measurement System to reach operating temperature.

13. On the Noise Figure Meter, press CALIBRATE twice. CALIBRATE is pressed twice to ensure that a calibration is performed only when desired. After CALIBRATE is pressed twice, the Noise Figure Test Set's YIG filter is fine tuned. Then,
-

OPERATOR'S CHECKS

Noise Figure Measurement System Check (cont'd)**Procedure
(cont'd)**

the Noise Figure Measurement System is calibrated. During the Noise Figure Test Set's YIG filter fine tuning, the following indications will be seen on the Noise Figure Meter, Noise Figure Test Set and System Local Oscillator:

NOTE

The fine tuning calibration will take from twenty-five to thirty seconds to complete.

Noise Figure Meter

- a. Each point that is being fine tuned and is included in band SSB3 (single sideband 3, on the Noise Figure Test Set; 2401 to 26500 MHz) is displayed in the left display. Frequency points that are included in bands SSB1 (single sideband 1, on the Noise Figure Test Set; 10 to 1600 MHz) or SSB2 (single sideband 2, on the Noise Figure Test Set; 1601 to 2400 MHz) are not displayed.
- b. "8971" appears in the INSERTION GAIN display.
- c. "CAL" appears in the NOISE FIGURE display.

Noise Figure Test Set

- a. The REMOTE annunciator is on.
- b. The LISTEN annunciator will flash.
- c. The annunciators for SSB1, SSB2 and SSB3 will be stepped from SSB1 to SSB2 to SSB3.

System Local Oscillator

- a. The REMOTE annunciator is on.
- b. The LISTEN annunciator will flash.
- c. The FREQUENCY display will move around.

When the Noise Figure Test Set YIG filter fine tuning is complete, the Noise Figure Measurement System is calibrated. The calibration will be done for each input gain setting at the frequencies set by START FREQ, STOP FREQ and STEP SIZE.

During calibration the following indications can be seen on the Noise Figure Meter, Noise Figure Test Set and System Local Oscillator:

Noise Figure Meter

- a. The frequency point being calibrated will be shown in the left display.
- b. The noise figure of the frequency point is shown in the NOISE FIGURE display.
- c. The INSERTION GAIN display is blank.

Noise Figure Test Set

- a. The REMOTE annunciator is on.
 - b. The LISTEN annunciator will flash.
 - c. The annunciators for SSB1, SSB2 and SSB3 will step from SSB1 to SSB2 to SSB3.
-

OPERATOR'S CHECKS

Noise Figure Measurement System Check (cont'd)**Procedure
(cont'd)****System Local Oscillator**

- a. The REMOTE annunciator is on.
 - b. The LISTEN annunciator will flash.
 - c. The FREQUENCY display will be changing.
14. When calibration is complete, press 17.1 SPECIAL FUNCTION. The annunciator for band DSB (double sideband) will light up on the Noise Figure Test Set.
 15. On the Noise Figure Meter, change the stop frequency by pressing SWEEP STOP FREQ, keying in 3000 and pressing ENTER.
 16. Observe the NOISE FIGURE display on the Noise Figure Meter. The noise figure displayed should be between 8 and 12 dB.

If the system performed as indicated in steps 13 through 16, the Noise Figure Measurement System is operating properly and this check is complete. If the system did not operate as indicated, go to step 17.
 17. Disconnect the Noise Figure Test Set from the Noise Figure Meter's SIB connector.
 18. If the Operator's Checks for the Noise Figure Meter have not been performed, perform the Operator's Checks for the Noise Figure Meter; a check for the System Local Oscillator is included. The Operator's Checks begin at paragraph 3-10, in this manual. If the Noise Figure Meter and System Local Oscillator are found to be operating properly, go to step 19. If either of the instruments is not operating properly, refer to the appropriate service manual.
 19. With both the Noise Figure Meter and System Local Oscillator operating properly, the following check should be completed before it is assumed that the Noise Figure Test Set is not operating properly.
 20. Disconnect all instruments from the Noise Figure Meter's HP-IB and SIB connectors. This test will verify that both buses are operating properly.
 21. Press 45.2 SPECIAL FUNCTION and 46.1 SPECIAL FUNCTION.
 22. Turn the Noise Figure Meter off and then back on. When "Fr CAL" is gone from the Noise Figure Meter's display, connect the SIB connector to the HP-IB connector.
 23. Press 98.1 SPECIAL FUNCTION; "SIB tEst" is displayed and there is a five second delay before the test begins. The results of the test will be displayed on the front panel using one of the error codes listed in the table below. The tests are performed as listed in the table. The first failure will abort the test.
 24. If an error is not encountered, the HP-IB and the SIB are operating properly. It is safe to assume that the Noise Figure Test Set is the instrument that is causing the Noise Figure Measurement System problem. Refer to the Noise Figure Test Set service manual for troubleshooting assistance.
 25. Remove the cable connecting the HP-IB and SIB connectors. Turn the Noise Figure Meter off and then back to on.
 26. Press 45.1 SPECIAL FUNCTION and 46.0 SPECIAL FUNCTION.
-

OPERATOR'S CHECKS

Noise Figure Measurement System Check (cont'd)

Procedure (cont'd)

Error Code	Description of Error Code	Corrective Action
E00	No Errors	
E75	A14U28, the interface hardware or the traces to A14U28 are bad.	Try another HP-IB cable; refer to Service ¹
E74	A14U2 or the interface hardware to A14U2 is bad. The interface hardware to A14U28 is good.	Try another HP-IB cable; refer to Service ¹
E01	May be caused by the following: REN or ATN line has failed, REN and/or ATN line drivers are bad or cable connecting the HP-IB and SIB connectors is defective.	Try another HP-IB cable; refer to Service ¹
E02	Data path has been broken.	Try another HP-IB cable; refer to Service ¹
E03	System Interface Bus could not send a message to the Hewlett-Packard Interface Bus.	Try another HP-IB cable; refer to Service ¹
E04	SRQ not being set by A14U28 or not being detected by A14U2.	Try another HP-IB cable; refer to Service ¹
E05	System Interface Bus could not serial poll Hewlett-Packard Interface Bus.	Try another HP-IB cable; refer to Service ¹
E06	Collision detect circuit not functioning.	Try another HP-IB cable; refer to Service ¹
E07	Hewlett-Packard Interface Bus could not address System Interface Bus.	Try another HP-IB cable; refer to Service ¹
E08	Hewlett-Packard Interface Bus could not send a message to the System Interface Bus.	Try another HP-IB cable; refer to Service ¹
¹ Service is in Section VIII of the Service Manual. The part number of the Service Manual is on the title page of this manual.		

3-14. REMOTE OPERATION

The Noise Figure Meter can be operated through the Hewlett-Packard Interface Bus (HP-IB). Bus compatibility, programming and data formats are described in the following paragraphs.

The Noise Figure Meter can operate in two mutually exclusive modes on the HP-IB:

1. **Normal Talker/Listener Mode.** This mode is used when the Noise Figure Meter is under the control of an HP-IB compatible computer or controller.
2. **Talk Only Mode.** This mode is used to output data to a device that is operating in the Listen Only Mode.

Most front panel functions, special functions and remote-only functions are programmable via HP-IB. Table 3-4 lists the functions that cannot be programmed via HP-IB.

A quick test of the Noise Figure Meter's HP-IB interface is described earlier in this section under Remote Operator's Checks. These checks verify that the Noise Figure Meter can respond to or send each of the applicable bus messages described in Table 3-3.

3-15. HP-IB Compatibility

The Noise Figure Meter has an open-collector, TTL, HP-IB interface which can be used with any HP-IB computing controller or computer for automatic system applications. The Noise Figure Meter is programmable via the HP Interface Bus. Its programming capability is described by the twelve HP-IB messages listed in Table 3-3. The Noise Figure Meter's compatibility with HP-IB is further defined by the following list of interface functions: SH1, AH1, T5, TE0, L4, LE0, SR1, RL1, PP0, DC1, DT1, C0, and E1. A more detailed explanation of these compatibility codes can be found in IEEE Standard 488-1978 (and the identical ANSI Standard MC1.1). For more information about HP-IB, refer to the Hewlett-Packard Electronic Instruments and Systems catalog and the booklet titled "Improving Measurements in Engineering and Manufacturing" (HP part number 5952-0058).

3-16. Remote Mode

Remote Capability. The Noise Figure Meter communicates on the bus in both remote and local modes. In remote, most of the Noise Figure Meter's

front panel controls are disabled (except for the LINE switch and LOCAL key). However, front panel displays remain active and valid. In remote, the Noise Figure Meter can be addressed to talk or listen. When addressed to listen, the Noise Figure Meter can issue the Data and Status Byte messages. Whether addressed or not, the Noise Figure Meter responds to the Clear (DCL), Local Lockout, Clear Lockout/Set Local, and Abort messages. In addition, the Noise Figure Meter can issue the Require Service Message.

Local-to-Remote Mode Changes. The Noise Figure Meter switches to remote operation upon receipt of the Remote message. The Remote message has two parts. They are:

- a. Remote enable bus control line (REN) set true.
- b. Device listen address received once (while REN is true).

When the Noise Figure Meter switches to remote, the REMOTE annunciator on the front panel turns on.

3-17. Local Mode

Local Capability. In local, the Noise Figure Meter's front panel controls are fully operational and the instrument responds to the Remote message. Whether addressed or not, the Noise Figure Meter also responds to the Clear, Local Lockout, Clear Lockout/Set Local, and the Abort messages. When addressed to talk, the Noise Figure Meter can issue Data messages and the Status Byte message, and whether addressed or not, it can issue the Require Service message.

Remote-to-Local Mode Changes. The Noise Figure Meter always switches to local from remote whenever it receives the Local message (GTL) or the Clear Lockout/Set Local message. (The Clear Lockout/Set Local message sets the Remote Enable control line [REN] false.) The Noise Figure Meter can also be switched to local by pressing the front panel LOCAL key (assuming Local Lockout is not in effect).

3-18. Addressing

The Noise Figure Meter interprets the byte on the eight HP-IB data lines as an address or a bus command if the bus is in the command mode. The command mode is defined as attention control line



Addressing (cont'd)

(ATN) true and interface clear control line (IFC) false. Whenever the Noise Figure Meter is being addressed (if in local or remote), either the TALK or LISTEN annunciator on the front panel turns on.

The Noise Figure Meter's HP-IB address is selected by special function. To change the HP-IB address or to determine the present address setting, refer to the discussion titled HP-IB and System Interface Bus (SIB) Addresses in the Detailed Operating Instructions at the end of this section.

Local Lockout. When a data transmission is interrupted, which can happen by pressing the LOCAL key to return the Noise Figure Meter to local mode, the data could be lost. This would leave the Noise Figure Meter in an unknown state. To prevent this, a local lockout is recommended. Local lockout disables the LOCAL key and allows return-to-local only under program control.

NOTE

Return-to-local can also be accomplished by turning the Noise Figure Meter's LINE switch to OFF, then back to ON. However, this technique has some disadvantages:

- a. It defeats the purpose and advantage of local lockout (that is, the system controller will lose control of a system element).*
- b. There are several HP-IB conditions that reset to default states at turn-on.*

3-19. Data Messages

The Noise Figure Meter communicates on the interface bus primarily with data messages. Data messages consist of one or more bytes sent over the bus' data lines when the bus is in the data

mode (attention control line [ATN] false). Unless it is set to Talk Only, the Noise Figure Meter receives data messages when addressed to listen. Virtually all instrument operations available in local mode can be performed in remote mode via data messages. The major exceptions are changing the LINE switch setting, using the Talk Only capability, and changing the HP-IB address of the Noise Figure Meter (refer to Table 3-4).

3-20. Receiving the Data Message

Depending on the status of Special Function 4, the Noise Figure Meter can either talk only, or talk and listen both (normal operation). The instrument responds to Data messages when it is enabled to remote (REN control line true) and it is addressed to listen. The instrument remains addressed to listen until it receives an Abort message or until its talk address or a universal unlisten command is sent by the controller.

Data Input Format. The Data message string, or program string, consists of a series of ASCII codes. Each code is typically equivalent to a front panel keystroke in local mode. Thus, for a given operation, the program string syntax in remote mode is the same as the keystroke sequence in local mode. Example 1 shows a typical program string.

Program Codes. All of the HP-IB codes normally used by the operator to control the Noise Figure Meter are given in Tables 3-8, 3-9, and 3-10. Table 3-8 provides an HP-IB code to parameter summary. Table 3-9 provides a special function to HP-IB code summary. Table 3-10 provides a front panel key to HP-IB code summary. All front panel keys except LOCAL have corresponding program codes. Some functions have an additional code which terminates the numeric data entry in Hz rather than MHz as indicated on the front panel.

EXAMPLE 1: Typical Program String

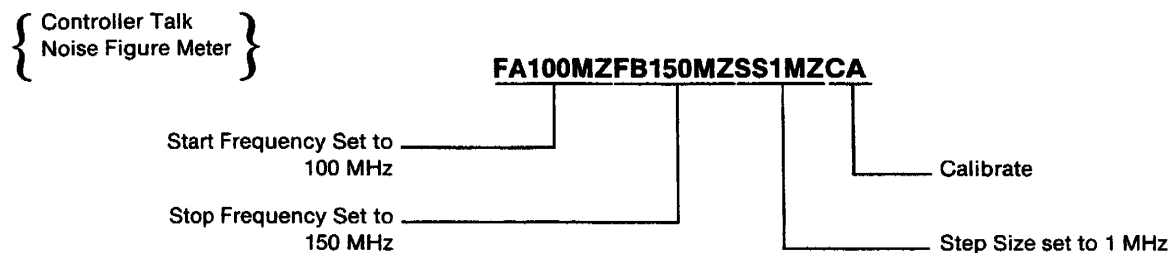

Table 3-3. Message Reference Table (1 of 2)

HP-IB Message	Applicable	Response	Related Commands and Controls	Interface Functions*
Data	Yes	Most Noise Figure Meter operations are bus programmable. All measurement results, special displays, and error outputs are available to the bus.		AH1, SH1, T5, TE0, L4, LEO
Trigger	Yes	If in remote and addressed to listen, the Noise Figure Meter makes a measurement according to previously programmed setup. It responds equally to bus command GET and program code T2, Trigger Execute (a Data message).	GET	DT1
Clear	Yes	The Noise Figure Meter is set to the same conditions established by pressing PRESET. Refer to Table 3-6.	DCL SDC	DC1
Remote	Yes	Remote mode is enabled when the REN bus control line is true. However, remote mode is not entered until the first time the Noise Figure Meter is addressed to listen. The front panel REMOTE annunciator lights when the instrument is actually in the remote mode. When entering the remote mode, no instrument settings or functions are changed, but all front panel keys except LOCAL are disabled.	REN	RL1
Local	Yes	The Noise Figure Meter returns to local mode (front panel control). It responds equally to the GTL bus command and the front panel LOCAL key. When entering the local mode, no instrument settings or functions are changed.	GTL	RL1
Local Lockout	Yes	Disables all front panel keys including LOCAL. Only the controller can return the Noise Figure Meter to local (front panel control).	LLO	RL1
Clear Lockout/ Set Local	Yes	The Noise Figure Meter returns to local (front panel control) and local lockout is cleared when the REN bus control line goes false. When entering local mode, no instrument settings or functions are changed.	$\overline{\text{REN}}$	RL1
Pass Control/ Take Control	No	The Noise Figure Meter cannot pass or take control of HP-IB.		C0

*Commands, Control lines, and Interface Functions are defined in IEEE Std 488-1978. Knowledge of these may not be necessary if your controller's manual describes programming in terms of the twelve HP-IB Messages shown in the left column.

Table 3-3. Message Reference Table (2 of 2)

HP-IB Message	Applicable	Response	Related Commands and Controls	Interface Functions*
Require Service	Yes	The Noise Figure Meter sets the SRQ bus control line true if an invalid program code is received (unless disabled). The following conditions also set SRQ true when they occur if they are enabled by the operator to do so: Data Ready, Noise Figure Meter Calibration Complete, SRQ on the System Interface Bus, Noise Figure Meter received control of the System Interface Bus, Instrument Error has occurred and Extended Status Byte enabled conditions are active.	SRQ	SR1
Status Byte	Yes	The Noise Figure Meter responds to a Serial Poll Enable (SPE) bus command by sending an 8-bit byte when addressed to talk. If the instrument is holding the SRQ control line true (issuing the Require Service message) bit 6 (RQS bit) in the Status Byte and the bit representing the condition causing the Require Service message to be issued will both be true. The bits in the Status Byte are latched but can be cleared by: <ol style="list-style-type: none"> 1. removing the causing condition, and 2. reading the Status Byte or 3. by sending the program code OS (output status) or RS (reset status). 	SPE SPD	TE5 TE0
Status Bit	No	The Noise Figure Meter does not respond to a parallel poll.		PP0
Abort	Yes	The Noise Figure Meter stops talking and listening.	IFC	T5 TE0
* Commands, Control lines, and Interface Functions are defined in IEEE Std 488-1978. Knowledge of these may not be necessary if your controller's manual describes programming in terms of the twelve HP-IB Messages shown in the left column.				

Complete HP-IB capability as defined in IEEE Std 488 and ANSI Std MC1.1 is: SH1, AH1, T5, TE0, L4, LE0, SR1, RL1, PP0, DT1, C0 and E1.

Table 3-4. Functions Not Programmable Via HP-IB

Function	Description
Control Function Selection (Special Function 4)	Normal Talker and Listener Talk Only
HP-IB Addresses (Special Function 40.0)	Display and Enter Noise Figure Meter Address
LINE Switch	Turns instrument ON and OFF.

Receiving the Data Message (cont'd)

Where more than one code is given for a function, either code will serve equally. However, the mnemonic code given is recommended since it is shorter and more closely represents the function selected. Also, the mnemonic code will make deciphering program code strings easier. The first codes given are the codes used in all programming examples in this manual.

The Noise Figure Meter's response to the ASCII character set is as follows:

- a. The ASCII characters used for the program codes are the alphabet (A through Z), the numbers 0 through 9, the period (.), and the minus (-).
- b. Lower case letters are treated the same as upper case letters.
- c. All other characters are ignored (however, they can not be used as the second character of a two-character HP-IB program code). If any of these other characters are used as a second character or if an undefined combination of valid characters is sent, SRQ is set if the HP-IB error condition has been enabled.

Turning Off Functions. When operating in local mode, CALIBRATE, and SINGLE and AUTO Sweep toggle on and off with successive keystrokes. In remote mode, these functions do not toggle on and off. Instead, both require that the HP-IB code W0 be used to turn off the function.

Programming Numeric Data. When programming tuned frequency or issuing any numeric data (other than specific HP-IB codes) to the Noise Figure Meter, certain precautions should be observed. Numeric data may consist of up to five digits, one decimal point, and a one-digit signed exponent.

Triggering Measurements with the Data Message. A feature that is available from both the front panel and via remote programming is the selection of free run, standby, or triggered operation of the Noise Figure Meter. The HP-IB codes and related Special Functions are discussed in detail in the Trigger Selection Detailed Operating Instruction later in this section.

3-21. Sending The Data Message

Depending on how the control functions are set, the Noise Figure Meter can either talk only, or talk and listen both (normal operation). If set to both

talk and listen, the instrument sends Data messages when addressed to talk. The instrument then remains configured to talk until it is unaddressed to talk by the controller. To unaddress the Noise Figure Meter, the controller must send either an Abort message, a new talk address, or a universal untalk command.

Talk Only Mode. If the Noise Figure Meter's Talk address is valid and Special Function 4.2 is selected, the Noise Figure Meter is placed in the Talk Only mode. In this mode the instrument is configured to send Data messages whenever the bus is in the data mode. Each time the measurement is completed, the measurement result will be output to the bus unless the listening device is not ready for data. If the listener is not ready for data, another measurement cycle is executed.

Data Output Format. As shown below, the output data is always formatted as a real constant: first the sign, then five digits (leading zeros not suppressed) followed by the letter E and a signed power-of-ten multiplier. The string is terminated by a carriage return (CR) and a line feed (LF), string positions 11 and 12. Data is always output in fundamental units (that is Hz, dB, etc.), and the decimal point (not sent) is assumed to be to the right of the fifth digit of the mantissa. Data values never exceed 1×10^9 . The one exception to this format is the voltmeter mode as shown in Table 3-5, HP-IB Data Output Summary.

The general data output format is as follows:

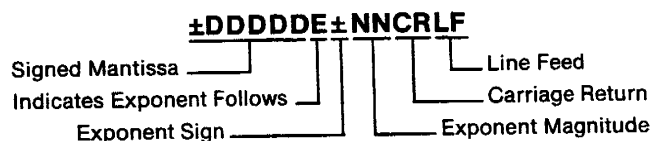

A summary of the different data outputs is listed in Table 3-5.

When an error is output to the bus, it follows the same 12-byte format described above except most of the numeric digits have predetermined values as shown below. Error outputs always exceed 90 000 000 000. The two-digit error code is represented by the last two digits of the five-digit mantissa. The error code can be derived from the string by subtracting 9×10^{10} , then dividing the result by 1 000 000.



Sending the Data Message (cont'd)

Table 3-5. HP-IB Data Output Summary

Front Panel Display ¹	HP-IB Output Format	Conditions
Left Display	+DDDDDE+06	Frequency
	±DDDDDE±NN	Data other than frequency
INSERTION GAIN ²	+90000E+06	Display is blank
	±DDDDDE±NN	Gain or Calibration data (GmKBm) is displayed.
NOISE FIGURE ²	+90000E+06	Display is blank
	±DDDDDE±NN	Normal display or second stage temperature
	+DDDDDE-05	Voltmeter mode
	+900DDE+06	Error codes where DD is the error code)
	+90000E+06	Data not ready. Sent when the instrument receives a read command while "... " is displayed in Trigger Hold mode. Also sent when display is blank.

¹ The HP-IB data output for mode H0 is NOISE FIGURE CR/LF. The HP-IB data output for mode H1 or H2 is Left Display, INSERTION GAIN, NOISE FIGURE CR/LF. EOI is set each time LF is sent.

² The HP-IB output has one more digit of resolution than the front panel display (except for the voltmeter mode which has two more digits of resolution than the front panel NOISE FIGURE display).

Error Output Format:

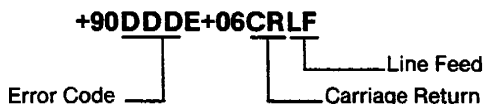

The Noise Figure Meter will output special HP-IB codes, for the NOISE FIGURE window, when a read of the Noise Figure Meter is attempted during the following operations: ENR editing, ENR cata-

log, Noise Figure Test Set Coarse or Fine Tuning Calibration. The special HP-IB codes are given below:

ENR Editing



ENR Catalog

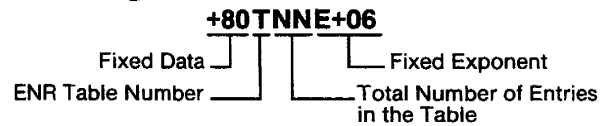

Noise Figure Test Set Fine Tuning Calibration

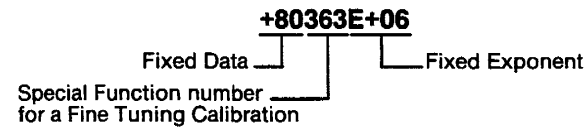

Noise Figure Test Set Coarse Tuning Calibration

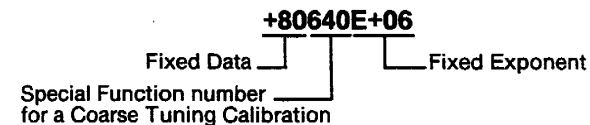

One purpose for these special codes would be to read back from the Noise Figure Meter until the codes stop being sent, which would mean the task is complete. This would be useful when doing a coarse or fine tune calibration.

Timeouts should not be used with these special codes. If a timeout is used, it should be at least sixty seconds. This is necessary because it may take the Noise Figure Meter many seconds to set up the special code for output. This is the case for coarse and fine tune calibration.

3-22. Receiving the Clear Message

The Noise Figure Meter responds to the Clear message by assuming the settings detailed in Table 3-6. The Noise Figure Meter responds equally to the Selected Device Clear (SDC) bus command when addressed to listen, and the Device Clear (DCL) bus command whether addressed or not. The Clear message clears any pending Require Service mes-

Table 3-6. Response to a Clear Message (or Pressing PRESET) (1 of 2)

Parameter	Condition
START FREQ	10 MHz
STOP FREQ	1600 MHz
STEP SIZE	20 MHz
SWEEP	Off
FREQUENCY	30 MHz
FREQ INCR	20 MHz
SMOOTHING	1
CALIBRATE	Off
MEASUREMENT	UNCORRECTED NOISE FIGURE
SPECIAL FUNCTION	<p style="text-align: center;">NOTE</p> <p><i>Most Special Functions are set to their zero suffix state (for example, Measurement Mode Selection is set to 1.0). Some are turned off (for example, Power Measurements). The following four Special Functions are not affected by either the Clear message or by pressing PRESET. These four Special Functions are affected by Special Function 0.9. For the default values of these four Special Functions, refer to Table 3-14, Special Function Summary, in the Special Functions Detailed Operating Instruction.</i></p> <ul style="list-style-type: none"> <i>a. Control Function Selection (Special Function 4).</i> <i>b. HP-B Addresses (Special Function 40).</i> <i>c. System LO Programs (Special Function 41).</i> <i>d. System LO Commands (Special Function 42).</i> <p><i>In addition, Service Request (Special Function 44) is set to enable HP-IB Code Error (Special Function 44.3).</i></p> <p>The following Special Functions are set to the indicated default values:</p>
IF (Special Function 3.0)	30 MHz
LO Frequency (Special Function 3.1)	10000 MHz
Smoothing Factor (Special Function 13.2)	1
Spot ENR (Special Function 5.3)	15.2 dB
T _{hot} (Special Function 5.4)	9893K
T _{cold} (Special Function 6)	296.5K
Oscilloscope Limits (Special Function 8)	
Noise Figure Lower Limit	0
Noise Figure Upper Limit	8
Gain Lower Limit	0
Gain Upper Limit	40
System LO Sideband Crossover frequency; Measurement Modes 1.5 through 1.9 (Special Function 17.2)	16 GHz

Table 3-6. Response to a Clear Message (or Pressing PRESET) (1 of 2)

Parameter	Condition
Noise Figure Measurement System	
Internal IF (Special Function 19)	
SSB2 IF	700 MHz
SSB3 IF	450 MHz
DBS IF	25 MHz
Plotter Functions (Special Function 25)	
Noise Pen Number	1
Gain Pen Number	2
Plot Title	HP 8970B Noise Figure Meter
Loss Compensation (Special Function 34)	
Before DUT	0 dB
Temperature of Losses	OK
After DUT	0 dB
Set Sequence (Special Function 35.2)	1 through 9

Receiving the Clear Message (cont'd)

sage and resets the Service Request Condition (Special Function 44) such that the Require Service message will be issued on HP-IB code errors only (Special Function 44.3).

Refer to Table 3-14 in the Special Functions Detailed Operating Instruction for a list of the Special Functions that are turned off or not affected by the Clear Message.

3-23. Receiving the Trigger Message

When in remote and addressed to listen, the Noise Figure Meter responds to a Trigger message by executing one measurement cycle. The Noise Figure Meter responds equally to a Trigger message (the Group Execute Trigger bus command [GET]) and a Data message, program code T2 (execute a measurement).

3-24. Receiving the Remote Message

The Remote message has two parts. First, the remote enable bus control line (REN) is held true; second, the device listen address is sent by the controller. These two actions combine to place the Noise Figure Meter in remote mode. Thus, the Noise Figure Meter is enabled to go into remote when the controller begins the Remote message, but it does not actually switch to remote until addressed to listen the first time. No instrument settings are changed by the transition from local to remote. When actually in remote, the Noise Figure Meter's

front panel REMOTE annunciator lights. When the Noise Figure Meter is being addressed (whether in remote or local), its front panel LISTEN or TALK annunciator turns on.

3-25. Receiving the Local Message

The Local message is the means by which the controller sends the Go To Local (GTL) bus command. If addressed to listen, the Noise Figure Meter returns to front panel control when it receives the Local message. If the instrument was in local lockout when the Local message was received, front panel control is returned, but lockout is not cleared. Unless it receives the Clear Lockout/Set Local message, the Noise Figure Meter will return to local lockout the next time it goes to remote. No instrument settings are changed by the transition from remote to local.

When the Noise Figure Meter goes to local mode, the front panel REMOTE annunciator turns off. However, when the Noise Figure Meter is being addressed (whether in remote or local), its front panel LISTEN or TALK annunciator lights.

If the Noise Figure Meter is not in local lockout mode, pressing the front panel LOCAL key might interrupt a Data message being sent to the instrument, leaving the instrument in a state unknown to the controller. This can be prevented by disabling the Noise Figure Meter's front panel keys entirely, using the Local Lockout message.

3-26. Receiving the Local Lockout Message

The Local Lockout message is the means by which the controller sends the Local Lockout (LLO) bus command. If in remote, the Noise Figure Meter responds to the Local Lockout Message by disabling the front panel LOCAL key. The local lockout mode prevents loss of data or system control due to someone accidentally pressing front panel keys. If, while in local, the Noise Figure Meter is enabled to remote (that is, REN is set true) and it receives the Local Lockout message, it will switch to remote mode with local lockout the first time it is addressed to listen. When in local lockout, the Noise Figure Meter can be returned to local only by the controller (using the Local or Clear Lockout/Set Local messages) or by setting the LINE switch to OFF and back to ON or by removing the bus cable.

3-27. Receiving the Clear Lockout/Set Local Message

The Clear Lockout/Set Local message is the means by which the controller sets the Remote Enable (REN) bus control line false. The Noise Figure Meter returns to local mode (full front panel control) when it receives the Clear Lockout/Set Local message. No instrument settings are changed by the transition from remote with local lockout to local. When the Noise Figure Meter goes to local mode, the front panel REMOTE annunciator turns off.

3-28. Receiving the Pass Control Message

The Noise Figure Meter does not respond to the Pass Control message because it does not have this control capability.

3-29. Sending the Require Service Message

The Noise Figure Meter sends the Require Service message by setting the Service Request (SRQ) bus control line true. The instrument can send the Require Service message in either local or remote mode. The Require Service message is cleared when a serial poll is executed by the controller or if a Clear message is received by the Noise Figure Meter. (During serial poll, the Require Service message is cleared immediately before the Noise Figure Meter places the Status Byte message on the bus.) There are seven conditions that can be enabled to cause the Require Service message to be sent when they occur. All seven conditions are described as follows:

1. Data Ready: When the Noise Figure Meter is ready to send any information except error codes.
2. HP-IB Code Error: When the Noise Figure Meter receives an invalid Data message. (Unless specifically disabled, this condition causes a Require Service message to be sent.)
3. Instrument Error: When any operator error (E10 through E49, and E99) is displayed by the Noise Figure Meter.
4. Calibration Complete: When a Noise Figure Meter calibration cycle is complete.
5. System Interface Bus SRQ: When an instrument on the System Interface Bus is issuing a Service Request (SRQ).
6. Received Control of the System Interface Bus: When the Noise Figure Meter has taken control of the System Interface Bus.
7. Extended Status Byte: When one of the enabled bits on the Extended Status Byte is true.

3-30. Enabling the Service Request Condition

Use Special Function 44 (or the related Service Request Condition HP-IB codes) to enable the Noise Figure Meter to issue the Require Service message on any of the conditions above. The Service Request Condition Special Function is entered from either the front panel or via the HP-IB. A description of the Service Request Condition Special Function and the procedure for enabling the various conditions are given in the following paragraphs:

NOTE

Each condition of the Status Byte can be enabled separately or all the conditions can be enabled at once (Special Function 44.7). Desired conditions of the Extended Status Byte must be enabled all at once (Special Function 44.9). If the enabled conditions of the Status Byte are changed, it is a good practice to first disable the SRQ capability and then enter the required enabled conditions.

A description of the Status Byte and Extended Status Byte bits is found in the HP-IB Syntax and Characteristics Summary.

Enabling the Service Request Condition (cont'd)

Table 3-7. Service Request Enabled Conditions Summary

HP-IB Code HP-IB	Special Function	Description
Q0	44.0	Disables the SRQ capability (clears all enabled conditions)
Q1	44.1	Enable Data Ready
Q2	44.2	Enable Noise Figure Meter Calibration Complete (not for Zero Frequency or IF Calibration)
Q3	44.3	Enable HP-IB Code Error
Q4	44.4	Enable SRQ on the System Interface Bus
Q5	44.5	Enable Noise Figure Meter received control on the System Interface Bus
Q6	44.6	Enable Instrument Error
RM	44.7	Set entire Status Byte Mask
Q8	44.8	Enable Extended Status Byte
RE	44.9	Set the Extended Status Byte Mask

a. Send the HP-IB Code Q0 to clear all the enabled conditions of the Status Byte. The enabled conditions of the Extended Status Byte are not cleared with Q0. The Extended Status Byte enabled conditions are cleared with RE0EN.

b. Each of the desired conditions of the Status Byte may be set individually (Special Functions 44.1 through 44.6) or all the conditions may be set at once (Special Function 44.7).

c. To set conditions individually, send the applicable HP-IB Codes from Table 3-7. To set all the desired conditions at once, send the total binary weight of the bit positions desired. The command sequence would be as follows: RM132EN.

RM is the HP-IB code for Special Function 44.7; 132 is the total binary weight of bits 2 and 7 of the Status Byte; EN is the HP-IB code for ENTER.

d. The conditions of the Extended Status Byte can't be enabled individually; the desired conditions must be enabled with Special Function 44.9.

e. To set the conditions of the Extended Status Byte, send the total binary weight of the bit positions desired. The command sequence would be as follows: RE36EN.

RE is the HP-IB code for Special Function 44.9; 36 is the total binary weight of bits 2 and 5 of the Extended Status Byte; EN is the HP-IB code for ENTER.

Normally, device subroutines for the Noise Figure Meter can be implemented simply by triggering measurements and then reading the output data. In certain applications, the controller must perform other tasks while controlling the Noise Figure Meter. Figure 3-12 illustrates a flow chart for developing device subroutines using the instrument's ability to issue the Require Service message when data is ready. This subroutine structure frees the controller to process other routines until the Noise Figure Meter is ready with data.

3-31. Sending the Status Byte Message

After receiving a Serial Poll Enable bus command (SPE) and when addressed to talk, the Noise Figure Meter sends a Status Byte message.

The Status Byte message consists of one 8-bit byte in which 7 of the bits are set according to the enabled conditions described above under Sending the Require Service Message. If one or more of the seven conditions are enabled and present, all the bits corresponding to the conditions and also bit 6, the RQS bit, will be set true (and the Require Service message is sent). If one of the above conditions occurs but has not been enabled by Special Function 44 or the HP-IB codes, neither the bit corresponding to the condition nor the RQS bit will be set (and the Require Service message will not be sent). The bit pattern of the Status Byte is shown in the HP-IB Syntax and Characteristics Summary.

Extended Status Byte. A second status byte is available but can only be accessed via the Output Status function (refer to the following paragraph for an explanation of the Output Status function). Bit 7 of the Status Byte indicates that an enabled condition on the Extended Status Byte is true. If Bit 7 is true, the second status byte should be accessed via the Output Status function to determine what caused Bit 7 to become true. The bit pattern can be interpreted with the information in the HP-IB Syntax and Characteristics Summary.

Sending the Status Byte Message (cont'd)

Output Status Function. After receiving the program code OS (Output Status) and when addressed to talk, the Noise Figure Meter sends two binary bytes, each 8 bits wide. The first byte is identical to the Status Byte of the Serial Poll. The second byte is the Extended Status Byte which provides additional information. Refer to the HP-IB Syntax and Characteristics Summary for a description of each Status Byte. Bits in the main Status Byte and Extended Status Byte are cleared upon execution of the Output Status (OS) or Reset Status (RS) program code.

3-32. Clearing the Status Byte

Once the Noise Figure Meter receives the serial poll enable bus command (SPE), it is no longer allowed to clear the Status Byte. However, it can add additional bits to the status byte if the bit has been enabled and the condition occurs.

After the Status Byte message has been sent it will be cleared if the Serial Poll Disabled (SPD) bus command is received, if the Abort message is received, or if the Noise Figure Meter is unaddressed to talk. Nonvolatile error messages are

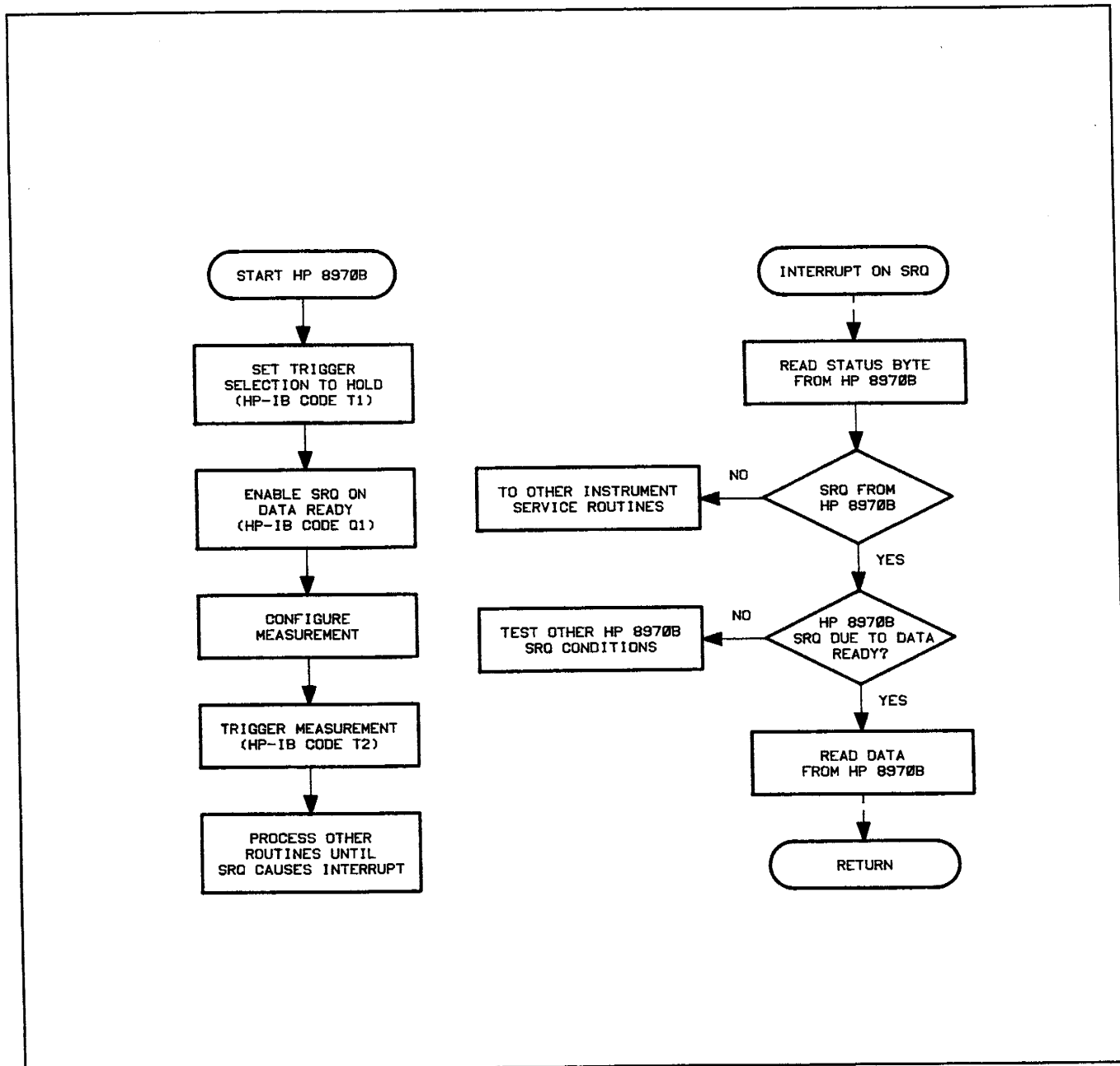

Figure 3-14. Example Flow Chart for Driving the Noise Figure Meter Using the Require Service Message (SRQ)

Clearing the Status Byte (cont'd)

also cleared when the Status Byte message is sent. Thus, some error messages that may have caused the Require Service Message to be issued disappear when a serial poll is performed. Refer to the Error Messages and Recovery Detailed Operating Instructions for a listing of volatile and nonvolatile errors. Regardless of whether or not the Status Byte message has been sent, the Status Byte and any Require Service message pending will be cleared if a Clear message is received.

3-33. Sending the Status Bit Message

The Noise Figure Meter does not respond to a Parallel Poll Enable (PPE) bus command and thus cannot send the Status Bit message.

3-34. Receiving the Abort Message

The Abort message is the means by which the controller sets the Interface Clear (IFC) bus control line true. When the Abort message is received, the Noise Figure Meter becomes unaddressed and stops talking or listening.

HP-IB SYNTAX AND CHARACTERISTICS SUMMARY

Address:

Selected and displayed on front panel using Special Function 44.0, Noise Figure Meter HP-IB Address.
Factory set to 8 decimal.

Numeric Data Input Format (Except in Voltmeter mode):*

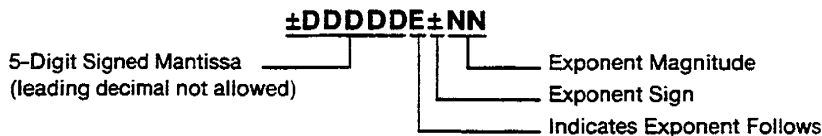

Output Formats: (Except in Voltmeter mode).*

HP-IB code H0 (43.0 SP): **±DDDDDE±NNCRLF**

HP-IB code H1 (43.1 SP): **±DDDDDE±NN, ±DDDDDE±NN, ±DDDDDE±NNCRLF**
and H2 (43.2 SP)

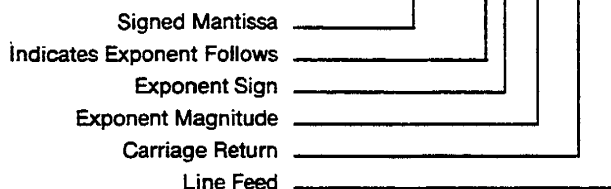

Errors:

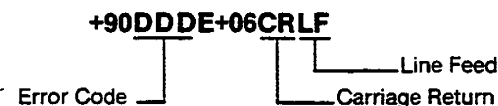

Special HP-IB error codes (used for ENR Editing, ENR Catalog and Noise Figure Test Set Coarse and Fine Tuning Calibration):

ENR Editing or Catalog:

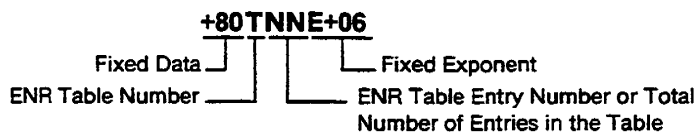

Noise Figure Test Set Coarse or Fine Tuning Calibration:

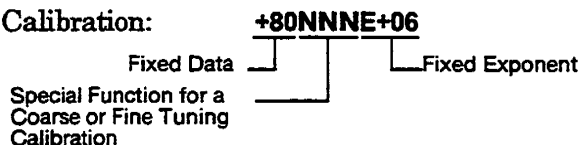

Reserved Number (used for the "—" special display or a blank display):

+90000E+06CRLF

Reserved Number (used for the "—", overflow in measurement or measured noise figure > 32 dB):

+90099E+06CRLF

Return to Local:

Front panel LOCAL key if not locked out.

* For information on the Voltmeter mode refer to Section VIII. Section VIII is in the Service Manual. The part number of the Service Manual is on the title page of this manual.



HP-IB SYNTAX AND CHARACTERISTICS SUMMARY (cont'd)

Status Byte:

Bit	7	6	5	4	3	2	1	0
Weight	128	64	32	16	8	4	2	1
Service Request Condition	Extended Status Byte	RQS Bit Require Service	Instrument Error	Received Control on SIB	SRQ on System Interface Bus	HP-IB Code Error	Noise Figure Meter Calibration Complete	Data Ready

- Notes
1. The condition indicated in bits 0—5 and 7 must be enabled to cause a Service Request by Special Function 44. Each condition can be enabled separately or all conditions can be enabled at once, using Special Function 44.7.
 2. The RQS bit (bit 6) is set true whenever any of the conditions of bits 0—5 and 7 are enabled and occur.
 3. For bit 7 to be enabled, both the Extended Status Byte mask and Special Function 44.8 must be enabled.

Extended Status Byte:

Bit	7	6	5	4	3	2	1	0
Weight	128	64	32	16	8	4	2	1
Service Request Condition	0 (always)	Power On Cycle	Plot Completed	Fine Tuning Calibration Completed	Coarse Tuning Calibration Completed	Noise Figure Test Set needs Coarse Tuning	Noise Figure Test Set needs Fine Tuning at Current Frequency	Noise Figure Test Set needs Fine Tuning Calibration (Special Function 36.3)

- Notes
1. The conditions indicated in bits 0 through 6 must be enabled to cause a Service Request, by Special Function 44.9. Special Function 44.9 enables all the conditions desired at once. The procedure is to press 44.9 SPECIAL FUNCTION, enter the total binary weights of the conditions desired and press ENTER.
 2. Special Function 44.8 must also be used to enable bit 7, in the status byte, to generate an SRQ.

Complete HP-IB capability as defined in IEEE Std 488-1978, and ANSI Std MC1.1 is: SH1, AH1, T5, TE0, L4, LE0, SR1, RL1, PP0, DC1, DT1, C0, E1.

Remote HP-IB Operation

In a noise figure measurement system the Test Set is normally controlled through the System Interface Bus (SIB).

The Test Set can also be operated through the Hewlett-Packard Interface Bus (HP-IB). HP-IB compatibility, programming and data formats are described in the following paragraphs.

All functions except the LINE switch are programmable via HP-IB.

A quick test of the Test Set's HP-IB interface is described in this section under HP-IB Checks. These checks verify that the Test Set can respond to or send each of the applicable bus messages described in Table 3-2.

3-10. HP-IB Program Codes

Table 3-1, Programming Quick Reference Guide, lists the most common programming codes for programming the Test Set with a controller, and defines the bits of the status byte.

3-11. HP-IB Compatibility

The Test Set's programming capability is described by the twelve HP-IB messages listed in Table 3-2. The Test Set's compatibility with HP-IB is further defined by the following list of interfaces: SH1, AH1, T6, TE0, L3, LE0, SR1, RL1, PP1, DC1, DT1, and C0. A more detailed explanation of these compatibility codes can be found in IEEE Standard 488-1978 and the identical ANSI Standard MC1.1.

3-12. Remote Mode

Remote Capability. The Test Set communicates on the bus in both remote and local modes. In remote, the Test Set can be addressed to talk or listen. When addressed to listen, the Test Set automatically stops talking and responds to the following messages: Data, Clear (SDC), Remote, Local, and Abort. When addressed to talk, the Test Set automatically stops

listening and sends any message that has previously been requested. Whether addressed or not, the Test Set responds to the Clear (DCL) and Abort messages.

Local-to-Remote Mode Changes. The Test Set switches to remote operation upon receipt of the Remote message. The Remote message has two parts. They are:

- a. Remote enable bus control line (REN) set true.
- b. Device listen address received once (while REN is true).

When the Test Set switches to remote, the REMOTE annunciator on the front panel turns on.

Table 3-7.1 . Programming Quick Reference Guide

BD_x	Sets all switches to Band x configuration. X can be a value for 1 - 4. Bands are defined as follows: Band 1, SSB1 (10-1600 MHz, 10-1600 MHz IF) Band 2, SSB2 (1601-2400 MHz, 700 MHz IF) Band 3, SSB3 (2401-18000/26500 MHz, 450 MHz IF) Band 4, DSB (2401-18000/26500 MHz, 25 MHz IF)
DN	Steps YIG-tuned filter frequency down by increment set with FN. This sets the frequency of the YIG-tuned filter needed for single-sideband measurements in SSB3.
FN value	Sets YIG-tuned filter step frequency in 1 MHz increments. This value is used with either the UP or DN step functions. The value should be terminated by using the carriage return and line feed. You may optionally use MZ to terminate, but all values entered are taken to be in MHz regardless of whether you use MZ to terminate or not.
FR value	Sets YIG-tuned filter frequency to the specified value in MH, where the value is in the range of 2400 to 18000/26500. The value should be terminated by a carriage return and line feed. You may optionally use MZ to terminate, but all values entered are taken to be in MHz regardless of whether you use MZ to terminate or not.

Table 3-7.1. Programming Quick Reference Guide (Cont.)

ST	Requests status message from the Test Set. The status message will be in the following format: "BDx,FRnnnnnMZ", where x in "BDx" is an ASCII value, 1 - 4 representing BD1 through BD4, and "FRnnnnnMZ" is the frequency of the YIG-tuned Filter (2400 to 18000/26500 MHz).
UP	Steps YIG-tuned filter frequency up by increment set with FN.
*CLS *IDN?	Clears Status Registers. The event status register and the status register are cleared. Requests status message showing the software revision date. Outputs the instrument identification in the following format: "HEWLETT PACKARD,8971B,0,YYWW"/"HEWLETT-PACKARD,8971C,0,YYWW". The YY is the year minus 60, and the WW is the week of the year of the software revision.
*RST	Resets the Test Set. The output message is cleared, and the HP-IB input parser is reset. Resets internal variables, including the heater control and post tuning drift correction loops. The HP 8971B/C is returned to SSB1 with the YIG set to 2401 MHz.

Bit Number	7	6	5	4	3	2	1	0
Bit Value	128	64	32	16	8	4	2	1
Function	Not Used	Request Service (RQS)	Event Status Register (ESB)	Message Available (MAV)	YIG Temp. Not Locked	Last Frequency was interpolated	Last Frequency Set From Coarse Tune Table	Last Frequency Set From EPROM Table

Status Byte

Bit 0: A frequency set command has come from the EPROM tables.

Bit 1: A frequency set command has come from the coarse tuning table.

Bit 2: A frequency set command used a point from the tuning tables that was interpolated

Bit 3: The HP 8971B/C YIG temperature loop has gone out to lock. This bit indicates that a RH command is needed to reset the temperature loop, or that the ambient air temperature should return to within 5 degrees centigrade of the point at which the last RH was issued. It is normal for the YIG temperature to take 15 minutes to lock after a power on.

Bit 4: The message Available Bit is set when the HP 8971B/C has a message that can be read over HP-IB.

Bit 5: The Event Status Register Bit is set when corresponding bits in the Event Status Enable Register and the Event Status Register are set to 1.

Bit 6: The Request Service Bit is set when corresponding bits in the Service Request Enable Register and the Status Byte are set to 1.

Bit 7: Not used.

3-13. Local Mode

Local Capability. In the local mode, the front panel REMOTE annunciator is off. However, even in local, the Test Set can send a Require Service message or a Status Byte message.

Remote-to-Local Mode Changes. The Test Set switches to local from remote whenever it receives a Local (GTL) or Clear Lockout/Set Local message. (The Clear Lockout/Set Local message sets the Remote Enable control line [REN] false.) The Test Set can also be switched to local by turning the LINE switch to OFF, and then to ON.

With the Remote-to-Local transition, the REMOTE annunciator turns off. However, when the Test Set is being addressed (whether in remote or local), its LISTEN or TALK annunciator is on.

3-14. Addressing

When the Remote Enable line (REN) and the Attention control line (ATN) are true and the Interface Clear control line (IFC) is false, the Test Set interprets the byte on the eight HP-IB data lines as an address or a command. When addressed, either the TALK or LISTEN annunciator is on.

3-15. Data Messages

The Test Set communicates on the interface bus primarily with Data messages. Data messages consist of one or more bytes sent over the bus' data lines when the bus is in the data mode (attention control line [ATN] false). The Test Set receives Data messages when addressed to listen.

3-16. Receiving Data Messages

The Test Set responds to Data messages when it is enabled to remote (REN control line true) and addressed to listen. The instrument remains addressed to listen until it receives an Abort message or until its talk address or a universal unlisten command is sent by the controller.

A data message is a string of two or more ASCII characters.

A summary of the most common programming codes and arguments is given in Table 3-1. Some programming examples are given in HP-IB Checks.

3-17. Receiving the Clear Message

The Test Set responds to the Clear message as follows:

1. Clears output message
2. Resets the HP-IB input parser.

It does not clear the status byte, and does not affect instrument state.

The message can take two forms: Selected Device Clear which the Test Set responds to only when addressed to listen, and Device Clear, which it responds to whether addressed or not. The Device Clear message does not affect addressing, while the Selected Device Clear message leaves the Test Set addressed to listen.

3-18. Receiving the Trigger Message

The Test Set does not respond to the Trigger message.

3-19. Receiving the Remote Message

The Remote message has two parts. First, the remote enable bus control line (REN) is held true; second, the device listen address is sent by the controller. These two actions combine to place the Test Set in remote mode. Thus, the Test Set is enabled to go into remote when the controller sets REN true, but it does not actually switch to remote until addressed to listen the first time. When actually in remote, the Test Set's front panel REMOTE annunciator lights.

3-20. Receiving the Local Message

The Local message sets the Remote Enable bus control line (REN) false. The Test Set returns to front panel control when it receives the Local message.

When the Test Set goes to local mode, the front panel REMOTE annunciator turns off. However, even in local, the Test Set can send the status byte.

3-21. Receiving the Local Lockout Message

The Test Set receives but ignores the the Local Lockout message, since there are no front panel controls and no Local key.

3-22. Receiving the Clear Lockout/Set Local Message

The Clear Lockout/Set Local message sets the Remote Enable (REN) bus control line false. The Test Set returns to local mode when it receives the Clear Lockout/Set Local message. When the Test Set goes to local mode, the front panel REMOTE annunciator turns off.

3-23. Receiving the Pass Control Message

The Test Set does not respond to the Pass Control message.

3-24. Sending the Require Service Message

The Test Set sends a Require Service message if the Service Request Enable Mask has been set to enable a a service request. This is accomplished by setting Service Request Enable Mask bits to 1. The command "SRE value", configures the Service Request Mask using a binary equivalent of the value entered. The value entered may be 0 through 255. Refer to Table 3-1 for status byte functions that may be enabled for a Require Service message.

The Test Set sends the message by setting the Service Request (SRQ) bus line true.

Once the Test Set is addressed to talk, the RQS bit is latched, even though Test Set's need for service may have changed.

3-25. Sending the Status Byte Message

After receiving a Serial Poll Enable bus command (SPE) and when addressed to talk, the Test Set sends a Status Byte message. The message consists of one 8-bit byte.

If the Test Set is holding the SRQ control line true (issuing the Require Service message), the RQS bit and the bit representing the condition causing the Require Service message to be issued will both be true. The bits in the Status Byte are latched but can be cleared by removing the causing condition and reading the Status Byte. For more information about the status byte, refer to Table 3-1.

3-26. Sending the Status Bit Message

The Test Set does not send the Status Bit message. It does not respond to the Parallel Poll Enable (PPE) bus command.

3-27. Receiving the Abort Message

The Abort message sets the Interface Clear (IFC) bus control line true. When the Abort message is received, the Test Set becomes unaddressed and stops talking or listening.

Table 3-7.2. HP-IB Message Reference Table

HP-IB Message	Applicable	Response	Related Command and Controls	Interface Functions*
Data	Yes	All Test Set functions except the LINE switch can be programmed.		AH1, SH1, T6, TE0, L4, LE0
Trigger	No	The Test Set does not respond to the Group Execute Trigger (GET) bus command.		DT0
Clear	Yes	Clears output message, resets HP-IB input parser, does not clear status byte, does not affect instrument state.	DCL SDC	DC1
Remote	Yes	Remote mode is enabled when the REN bus control line is true. However, remote mode is not entered until the first time the Test Set is addressed to listen. The front panel REMOTE annunciator lights when the instrument is actually in the remote mode. No instrument settings are changed.	REN	RL1
Local	Yes	The Test Set returns to local mode. However, there are no front panel controls on the Test Set.	GTL	RL1
Local Lockout	No	The Test Set receives but ignores the Local Lockout message, since there are no front panel controls.	REN	RL1

Table 3-7.2. HP-IB Message Reference Table (Cont.)

HP-IB Message	Applicable	Response	Related Command and Controls	Interface Functions*
Clear Lockout/Set Local	Yes	The Test Set returns to local when the REN bus control line goes false.	REN	RL1
Pass Control/Take Control	No	The Test Set has no controller capability.		C0
Require Service	Yes	If the SRQ mask is set, (see Table 3-1 for a description of *SRE), and if one of the following conditions exists, then SRQ will be true. 1) Last frequency from EPROM Table. 2) Last frequency from coarse table. 3) Last frequency was interpolated. 4) YIG temperature not locked. 5) Message available. 6) Event status register conditions active.	SRQ	SR1
Status Byte	Yes	The Test Set responds to a Serial Poll Enable (SPE) bus command by sending an 8-bit status byte when addressed to talk. If the Test Set is holding the SRQ control line true (issuing the Require Service message), the RQS bit and the bit representing the condition causing the Require Service message to be issued will		

Table 3-7.2. HP-IB Message Reference Table (Cont.)

HP-IB Message	Applicable	Response	Related Command and Controls	Interface Functions*
		both be true. The bits in the Status Byte are latched but can be cleared by removing the causing condition and reading the Status Byte.	SPE, SPD	T5
Status Bit	No	The Test Set does not respond to a Parallel Poll Enable (PPE) bus command.		PP0
Abort	Yes	The Test Set stops talking and listening.	IFC	T6, TE0 L4, LE0

*Control lines and Interface Functions are defined in IEEE Std 488-1978. Knowledge of these may not be necessary if your controller's manual describes programming in terms of the twelve HP-IB Messages shown in the table above.

Complete HP-IB capability as defined in IEEE Std 488 and ANSI Std MC1.1 is: SH1, AH1, T5, TE0, L3, LE0, DT1, DC1, RL1, C0, SR1, and PP1.

Table 3-7.3. HP-IB Program Codes

Program Code	Parameter
AD value BD value CAD value CF value *CLS CS CT DF DH	Take internal voltage reading on channel 0-7, return 1 byte result. Configure switches for frequency band 1 - 4 Take internal voltage reading on channel 0-7, return ASCII 0-255 Add current DAC settings to fine tune table for this frequency Clear the status byte and event status register Save fine tune table into the coarse tune table (10,000 time limit) Clears fine tuning table Reports Post tuning drift factor Disable automatic YIG-tuned filter temperature control

Table 3-7.3 . HP-IB Program Codes (Cont.)

Program Code	Parameter
DN	Step YIG-tuned filter frequency down by amount set with FN
DP	Disable YIG-tuned filter Post tuning drift compensation
DS	Report Post tuning drift factor after FN,UP,DN
DY value	Decrement YIG-tuned filter DAC setting
EC	Enable calibration save command. See "CS" command
EH	Enable YIG-tuned filter temperature control
EP	Enable YIG-tuned filter Post tuning drift control
ERR?	Output last device dependent error
*ESE	Set Event Status Enable register
*ESE?	Output Event Status Enable register
*ESR?	Output Event Status Register
ETC value	Set ET control register
ETL value	Set ET LEDs on front panel
FN value	Set YIG-tuned filter step frequency in 1 MHz increments
FR value	Set YIG-tuned filter filter to specified frequency when in SSB3
HY	Do hysteresis correction on YIG-tuned filter DAC and leave YIG at 0 MHz
*IDN?	Outputs instrument identification
IW value	Inspect a word of memory at specified address
IY value	Increment YIG-tuned filter DAC setting
NWC	Returns total number of times the CS command has been done
OC	Output control loop status
OD	Output Scale and YIG-tuned filter DAC settings
RH	Resets YIG-tuned filter heater regulation set point
*RST	Resets instrument
SA value	Set ambient offset DAC to new value
SD	Outputs instrument identification
SH value	Set heater DAC to specified value
*SRE value	Set the Service request enable register
*SRE?	Output contents of Service Request Enable Register
SS value	Set YIG-tuned filter Scale DAC to a value 0 - 4095
ST	Returns instrument status
*STB?	Returns the Status Byte but does not clear it
SY value	Set main YIG-tuned filter DAC to a value 0 - 65535
UP	Steps YIG-tuned filter frequency up by setting set with FN



3-46.12 *This Page Intentionally Left Blank*

Table 3-8. Noise Figure Meter HP-IB Code to Parameter Summary (1 of 4)

HP-IB Code HP-IB	Parameter	HP-IB Code HP-IB	Parameter
AC	System LO Auxiliary Commands		Input Gain Calibration
AD	Sets the RAM address for modification/ inspection or ROM address for inspection and disables auto-increment mode	C0	+20, +10, and 0 dB
		C1	+10, 0, and -10 dB
AF	Enable Smoothing Factor	C2	0, -10, and -20 dB
AI	Sets the RAM address for modification/ inspection or ROM address for inspection and enables auto-increment mode	C3	-10, -20, and -30 dB
		DA	Disable auto sweep abort
		DB	dB
		DC	Disable Error 48 (E48)
		DD	Perform a Selective Device Clear of the Pass Through Device on the System Interface Bus
A0	Output to Oscilloscope Noise Figure and Gain	DE	DECREASE Smoothing
A1	Test Pattern	DF	Measurement frequency is shown in the left display
A2	Noise Figure Only	DG	Interpolated measurements disabled above 1600 MHz in Modes 1.5 through 1.9
A3	Gain Only	DI	Input to Noise Figure Meter (Modes 1.0 through 1.4) or Input to Noise Figure Test Set (Modes 1.5 through 1.9) displayed ↓ (Step down)
A4	Plot Noise Figure (for X-Y Recorder)	DN	Disable Auto Pass Control
A5	Plot Gain (for X-Y Recorder)	DP	Perform a Device Clear on the System Interface Bus, if the Noise Figure Meter is the Active Controller.
A6	X Axis is Noise Figure and Y Axis is Gain (Strip Chart Mode)	DS	Enable Display Test
A7	Enable recorder test		Noise Source Temperature Units for Data Input
A8	Oscilloscope display cursor enabled	D0	K
A9	Oscilloscope display cursor disabled	D1	°C
BA	All displays are blanked	D2	°F
BF	Left display is blanked	EA	Display and Enter System LO SIB Address
B0	Double Sideband	EC	ENR Table for Calibration
B1	Lower Single Sideband	EG	Enable Interpolated Measurements in Modes 1.5 through 1.9
B2	Upper Single Sideband		Noise Figure Meter YIG Filter Tuning Functions
B3	Signal Up Conversion $IF = F_{\text{signal}} + F_{LO}$	EH	Enable Hysteresis Calibration when Frequency is Changed
B4	Noise Figure Test Set single sideband operation; Modes 1.5 through 1.9	EM	ENR Table for Measurement
B5	Noise Figure Test Set double sideband operation; Modes 1.5 through 1.9	EN	ENTER
CA	CALIBRATE	EP	Enable Auto Pass Control
CC	Cold Calibration (Manual Measurement)	ER	Recalls Last Error Issued
CF	Upper and lower sideband crossover frequency selection; Modes 1.5 through 1.9		Measurement Modes
CH	Hot Calibration (Manual Measurement)	E0	Mode 1.0
CI*	Calibrate IF Attenuators*	E1	Mode 1.1
CP	Noise Figure Test Set Coarse Tuning Calibration		
CR	Noise Figure Meter releases control of the System Interface Bus		
CS	Initialize Special Functions		
CT	Noise Figure Meter takes control of the System Interface Bus		
CU	Selects Upper Frequency of Noise Figure Test Set		

* If code CI is used, the gain accuracy specification will be degraded from 0.15 dB to a typical value of 0.25 dB. For more information, refer to "Calibration, IF Attenuators" Detailed Operating Instruction.

Table 3-8. Noise Figure Meter HP-IB Code to Parameter Summary (2 of 4)

HP-IB Code HP-IB	Parameter	HP-IB Code HP-IB	Parameter
	Measurement Modes (cont'd)		Special Function Catalog (cont'd)
E2	Mode 1.2	G7	Line 7 Status
E3	Mode 1.3	G8	Line 8 Status
E4	Mode 1.4	HC	Display and Enter Pass Control System Interface Bus Address
E5	Mode 1.5	HP	Display and Enter Plotter System Interface Bus Address
E6	Mode 1.6	HS	Display and Enter System Interface Bus Address
E7	Mode 1.7	HT	Display and Enter Noise Figure Test Set System Interface Bus Address
E8	Mode 1.8	HZ	Hz
E9	Mode 1.9		HP-IB Data Output
FA	START FREQ	H0	NOISE FIGURE Display Only
FB	STOP FREQ	H1	Left, INSERTION GAIN, and NOISE FIGURE Displays
FC	Custom LO CW Prefix and Suffix	H2	During Calibration the Frequency, Calibration Data (GKB) and Second Stage Temperature are output.
FD	Disable Noise Figure Test Set Fine Tuning Calibration with Noise Figure Measurement System Calibration; warning (E28) when fine tune needed	IF	IF (for Modes 1.1, 1.3, 1.6 and 1.8)
FF	Noise Figure Test Set Fine Tuning Calibration at the current Frequency	IH	IF Attenuator Hold
FN	FREQ INCR	IN	INCREASE Smoothing
FR	FREQUENCY	IS	Perform an Interface Clear on the System Interface Bus, if the Noise Figure Meter is the System Controller.
FT	Noise Figure Test Set Fine Tuning Calibration with Noise Figure Measurement System Calibration; warning (E28) when fine tune needed.		IF Attenuation Selection
FW	Disable Noise Figure Test Set Fine Tuning Calibration before Noise Figure Measurement System Calibration and disable Error 28 (E28)	I0	Auto
F0	Smoothing Factor = 1	I1	0 dB
F1	Smoothing Factor = 2	I2	5 dB
F2	Smoothing Factor = 4	I3	10 dB
F3	Smoothing Factor = 8	I4	15 dB
F4	Smoothing Factor = 16	I5	20 dB
F5	Smoothing Factor = 32	I6	25 dB
F6	Smoothing Factor = 64	I7	30 dB
F7	Smoothing Factor = 128	I8	35 dB
F8	Smoothing Factor = 256		System LO Programs
F9	Smoothing Factor = 512	J0	HP 8350B Sweep Oscillator
GL	Gain Lower Limit (for Oscilloscope)	J2	HP 8671B/8672A Syn. Signal Generator
GP	Select Gain Pen Number	J3	HP 8673B/C/G Syn. Signal Generator
GU	Gain Upper Limit (for Oscilloscope)	J4	HP 8340B Sweep Oscillator
	Special Function Catalog	J5	Custom Local Oscillator Program
G0	Scan Catalog Lines		Keyboard Test
G1	Line 1 Status	KY	Display Key Codes
G2	Line 2 Status	K1	Key Test — Row 1
G3	Line 3 Status	K2	Key Test — Row 2
G4	Line 4 Status	K3	Key Test — Row 3
G5	Line 5 Status		
G6	Line 6 Status		

Table 3-8. Noise Figure Meter HP-IB Code to Parameter Summary (3 of 4)

HP-IB Code HP-IB	Parameter	HP-IB Code HP-IB	Parameter
	Key Test (cont'd)		Power Measurements
K4	Key Test — Row 4	N5	SOURCE Off (Uncal)
K5	Key Test — Row 5	N6	SOURCE On (Uncal)
K6	Key Test — Row 6	N7	SOURCE Off (Cal)
K7	Key Test — Row 7	N8	SOURCE On (Cal)
K8	Key Test — Row 8	OS	Output Both Status Bytes
LA	Loss Compensation before DUT	PA	Plot Grid and Data
LB	Loss Compensation after DUT	PC	Custom LO Power Prefix and Suffix
LD	Disable System LO on System Inter- face Bus	PD	Plot Data Only
LE	Enable System LO on System Inter- face Bus	PF	Perform Noise Figure Test Set Fine Tuning Calibration
LF	LO Frequency (for Modes 1.2, 1.4, 1.7 and 1.9)	PG	Plot Grid and Axes Labels
LL	Go to Lower Left (for X-Y Recorder)	PI	Plotter is on the System Interface Bus
LT	Temperature of Losses	PL	System LO Power Level
L0	Loss Compensation Off	PM	Plot Data read on HP-IB
L1	Loss Compensation On	PR	PRESET
MB	Selects Modification or Inspection of a Byte in RAM or Inspection of a Byte in ROM.	PS	System LO CW Prefix and Suffix
MC	Cold Manual Measurement	PT	Display and Enter the Address of the Pass Through Device on the System Interface Bus
MF	Selects Modification or Inspection of a Floating Point Value in RAM or Inspec- tion of a Floating Point Value in ROM.	P0	Normal Display (to return from displaying manual measurement results)
MH	Hot Manual Measurement	P1	Display Manual Measurement Results
MN	System LO Minimum Frequency in MHz		Sequence Functions
MW	Selects Modification or Inspection of a Word in RAM or Inspection of a Word in ROM.	QA	Automatic
		QC	Clear
		QM	Manual
		QS	Set
			Service Request
MX	System LO Maximum Frequency in MHz	Q0	Disable SRQ Capability
MZ	MHz	Q1	Enable Data Ready to Cause SRQ
M1	UNCORRECTED NOISE FIGURE	Q2	Enable Cal Complete to Cause SRQ
M2	CORRECTED NOISE FIGURE AND GAIN	Q3	Enable HP-IB Code Error to Cause SRQ
NC	Noise Figure Meter is not system control- ler on the System Interface Bus	Q4	Enable SRQ on the System Interface Bus to Cause SRQ
ND	Sets all ENR Values to 15.20 dB and Noise Source ID No. to 00000.	Q5	Enable Noise Figure Meter received control on the System Interface Bus to Cause SRQ
NE	Enter and Use ENR	Q6	Enable Instrument Error to cause SRQ
NL	Noise Figure Lower Limit (for Oscilloscope)	Q8	Enable Extended Status Byte to Cause SRQ
NP	Selects the Noise Pen Number		RECALL
NR	Enter ENR Table	RC	RECALL
NS	Noise Source Catalog	RE	Set Extended Status Byte Mask
NU	Noise Figure Upper Limit (for Oscilloscope)	RH	RF Attenuator Hold
	Noise Figure Display Units	RM	Set Status Byte Mask
N0	F dB	RS	Reset Status Bytes
N1	F		RF Attenuation Selection
N2	Y dB	R0	Auto
N3	Y	R1	+20 dB
N4	Te K	R2	+10 dB

Table 3-8. Noise Figure Meter HP-IB Code to Parameter Summary (4 of 4)

HP-IB Code HP-IB	Parameter	HP-IB Code HP-IB	Parameter
	RF Attenuation Selection (cont'd)		Voltmeter Mode
R3	0 dB	VC	Noise Source Off
R4	-10 dB	VH	Noise Source On
R5	-20 dB	VP	Display Pass Through Address of Noise Figure Meter
R6	-30 dB		Exponential Smoothing
SB	Noise Figure Meter does a Serial Poll on the System Interface Bus	V0	Arithmetic Smoothing
SC	Noise Figure Meter is System Controller on the System Interface Bus	WT	Enter Plot Name
SD	Displays Current Software Date	W0	Sweep Off
SE	Display Current ENR	W1	AUTO Sweep
SI	Display IF Attenuator Setting	W2	SINGLE Sweep
SN	Enter Noise Source Identifier		Recorder Test Functions
SP	SPECIAL FUNCTION	XV	X-Axis Test
SQ	SEQ		Display Resolution
SR	Display RF Attenuator Setting	X0	Maximum Resolution
SS	STEP SIZE	X1	Less Resolution on Noise Figure
ST	STORE	X2	Less Resolution on Gain
S0	Use ENR Table		Recorder Test Functions
S1	Use Spot ENR	YV	Y-Axis Test
	Noise Figure Measurement System Internal IF Selection		Frequency Calibration
S2	Display and Enter Internal IF for SSB2	Y0	Automatic
S3	Display and Enter Internal IF for SSB3	Y1	Disable Frequency Cal
S4	Display and Enter Internal IF for DSB	Y2	Perform 1 Frequency Cal
S5	Display Noise Figure Meter Input Frequency	Y8	Disables Debug Oscilloscope Plots
TC	T _{cold}	Y9	Enables Debug Oscilloscope Plots
TD	Disable Noise Figure Test Set on the System Interface Bus		HP 8757 Scalar Analyzer Control
TE	Enable Noise Figure Test Set in Modes 1.5 through 1.9	ZP	Enable plot to HP 8757 Scalar Analyzer.
TH	T _{hot}	ZQ	Disable plot to HP 8757 Scalar Analyzer.
TM	System LO Settling Time	ZR	Display and enter HP 8757 Scalar Analyzer System Interface Bus Address.
TS	Enable Noise Figure Test Set in Modes 1.0 through 1.9	ZS	Number of measurement frequencies per HP 8757 Scalar Analyzer display refresh.
	Trigger Selection		Individual RF Attenuator Selection
T0	Free Run	Z0	Select RF Thru Path
T1	Hold	Z1	Select 10 dB Pad No. 1
T2	Execute	Z2	Select 20 dB Input Amplifier
UL	Display User Controlled Local Oscillator Frequency; Modes 1.5 through 1.9	Z4	Select 10 dB Pad No. 2
UP	↑ (Step up)	Z5	Select 10 dB Pad No. 3
UR	Go to Upper Right (for X-Y Recorder)		
	Noise Figure Meter YIG Filter Tuning Functions		
UY	YIG DAC is Updated when Frequency is Changed		
U0	0 MHz Hold Off		
U1	0 MHz Hold On		

Table 3-9. Special Function to HP-IB Code (1 of 7)

Special Function		HP-IB Code	Description
Name	Code*	HP-IB	
Initialize Special Functions	0.0	CS	Initializes many Special Functions.
Initialize Special Functions and Set Defaults	0.9	None	Initializes all Special Functions and Sets all Defaults to Factory Set Conditions.
Measurement Mode Selection	1.0	E0	Mode 1.0 (10—1600 MHz measurement)
	1.1	E1	Mode 1.1 (fixed IF; variable freq. Sys. LO)
	1.2	E2	Mode 1.2 (variable IF; fixed freq. Sys. LO; SSB)
	1.3	E3	Mode 1.3 (fixed IF; variable freq. Sys. LO; mixer is DUT)
	1.4	E4	Mode 1.4 (variable IF; fixed freq. Sys. LO; mixer is DUT)
	1.5	E5	Mode 1.5 (10 to 26500 MHz)
	1.6	E6	Mode 1.6 (fixed IF; variable frequency User Controlled LO)
	1.7	E7	Mode 1.7 (variable IF; fixed frequency User Controlled LO; SSB)
	1.8	E8	Mode 1.8 (fixed IF; variable frequency User Controlled LO; mixer is DUT)
	1.9	E9	Mode 1.9 (variable IF; fixed frequency User Controlled LO; mixer is DUT)
Sideband Frequency Offset	2.0	B0	Double Sideband (no offset)
	2.1	B1	Lower Single Sideband ($F_{\text{signal}} < F_{\text{LO}}$)
	2.2	B2	Upper Single Sideband ($F_{\text{signal}} > F_{\text{LO}}$)
	2.3	B3	Signal Up Conversion $F_{\text{(IF)}} = F_{\text{(signal)}} + F_{\text{(LO)}}$
Enter IF and LO Frequencies	3.0	IF	IF (for Modes 1.1, 1.3, 1.6 and 1.8)
	3.1	LF	LO (for Modes 1.2, 1.4, 1.7 and 1.9)
	3.2	UL	Displays User Controlled LO Frequency in Modes 1.6 through 1.9
Control Function Selection	4.0	none	Normal Talker and Listener
	4.2	none	Talk Only
ENR, T_{hot} Settings and ENR Table Selection	5.0	S0	Use ENR Table
	5.1	S1	Use Spot ENR
	5.2	SE	Display Current ENR in dB
	5.3	NE	Enter and Use Spot ENR
	5.4	TH	Enter and Use T_{hot}
	5.5	SN	Enter Noise Source Identifier
	5.6	NS	Noise Source Catalog
	5.7	EC	ENR Table for Calibration
	5.8	EM	ENR Table for Measurement
	T_{cold} Setting Output to Oscilloscope	6.0	TC
7.0		A0	Noise Figure and Gain
7.1		A1	Test Pattern
7.2		A2	Noise Figure Only
7.3		A3	Gain Only
7.4		A8	Oscilloscope Display Cursor Enabled
7.5		A9	Oscilloscope Display Cursor Disabled

*Most Special Functions can be programmed using either the code number followed by SP or the HP-IB Code.

Table 3-9. Special Function to HP-IB Code (2 of 7)

Special Function		HP-IB Code	Description
Name	Code*	HP-IB	
Enter Oscilloscope Limits	8.1	NL	Noise Figure Lower Limit
	8.2	NU	Noise Figure Upper Limit
	8.3	GL	Gain Lower Limit
	8.4	GU	Gain Upper Limit
Power Measurements	9.1	N5	SOURCE Off (uncal)
	9.2	N6	SOURCE On (uncal)
	9.3	N7	SOURCE Off (cal)
	9.4	N8	SOURCE On (cal)
Noise Figure Display Units	10.0	N0	F dB
	10.1	N1	F
	10.2	N2	Y dB
	10.3	N3	Y
	10.4	N4	Te K
Select Noise Source Temperature Units for Data Input	11.0	D0	K
	11.1	D1	°C
	11.2	D2	°F
Display Resolution	12.0	X0	Maximum Resolution
	12.1	X1	Less Resolution on Noise Figure
	12.2	X2	Less Resolution on Gain
Smoothing (Averaging)	13.0	V0	Exponential Smoothing
	13.1	V1	Arithmetic Smoothing
	13.2	AF	Smoothing Factor
Manual Measurement Functions	14.1	MC	Cold Measurement (SOURCE-off)
	14.2	MH	Hot Measurement (SOURCE-On)
	14.3	CC	Cold Calibration (SOURCE-Off)
	14.4	CH	Hot Calibration (SOURCE-On)
	15.0	P0	Display Current Measurement
	15.1	P1	Display Manual Measurement Results
Display Control	16.0	DF	Displays Measurement Frequency in Left Display
	16.1	DI	Displays Input to Noise Figure Meter (Modes 1.0 through 1.4) or Input to Noise Figure Test Set (Modes 1.5 through 1.9) in Left Display
	16.2	BF	Left Display is Blanked
	16.3	BA	All Displays are Blanked
Noise Figure Test Set Internal Sideband Frequency Offset	17.0	B4	Single Sideband Operation (Modes 1.5 through 1.9)
	17.1	B5	Double Sideband Operation (Modes 1.5 through 1.9)
	17.2	CF	Upper and Lower Sideband Crossover Frequency Selection
Noise Figure Measurement System Internal IF	19.2	S2	Internal IF for SSB2
	19.3	S3	Internal IF for SSB3
	19.4	S4	Internal IF for DSB
	19.5	S5	Display Noise Figure Meter Input Frequency

*Most Special Functions can be programmed using either the code number followed by SP or the HP-IB Code.

Table 3-9. Special Function to HP-IB Code (3 of 7)

Special Function		HP-IB Code	Description
Name	Code*	HP-IB	
Recorder Functions	20.0	LL	Go to Lower Left
	21.0	UR	Go to Upper Right
	22.0	A4	Plot Noise Figure
	23.0	A5	Plot Gain
	24.0	A6	X-AXIS Output is Noise Figure and Y-AXIS Output is Gain (Strip Chart mode)
Plotter Functions	25.0	PA	Plot Grid and Data
	25.1	PG	Plot Grid and Axes Labels
	25.2	PD	Plot Data Only
	25.3	NP	Select Noise Pen Number
	25.4	GP	Select Gain Pen Number
	25.5	WT	Select Plot Name
Trigger Selection	30.0	T0	Free Run
	30.1	T1	Hold
	30.2	T2	Execute
Frequency Calibration	31.0	Y0	Automatic: See Calibration, Frequency (DOI)
	31.1	Y1	Disable Frequency Cal
	31.2	Y2	Perform 1 Frequency Cal
Input Gain Calibration	32.0	C0	+20, +10 and 0 dB
	32.1	C1	+10, 0 and -10 dB
	32.2	C2	0, -10 and -20 dB
	32.3	C3	-10, -20 and -30 dB
IF Attenuators Calibration**	33.1**	CI**	Calibrate IF Attenuators**
Loss Compensation	34.0	L0	Off
	34.1	L1	On
	34.2	LA	Enter Loss before DUT in dB
	34.3	LT	Enter Temperature of Losses
	34.4	LB	Enter Loss after DUT in dB
Sequence Functions	35.0	QM	Manual
	35.1	QA	Automatic
	35.2	QS	Set
	35.3	QC	Clear
Noise Figure Test Set YIG Filter Fine Tuning Calibration	36.0	FT	Fine Tuning Calibration with Noise Figure Measurement System Calibration; enable Warning (E28) if Fine Tuning is needed.
	36.1	FD	Disable Fine Tuning Calibration before Noise Figure Measurement System Calibration.
	36.2	FW	Disable Fine Tuning Calibration before Noise Figure Measurement System Calibration and Disable Warning (E28) if Fine Tuning is needed.
	36.3	PF	Fine Tuning Calibration from Start to Stop Frequencies and Disable Fine Tuning Calibration before Noise Figure Measurement System Calibration.

*Most Special Functions can be programmed using either the code number followed by SP or the HP-IB Code.

**If Special Function 33.1 is used, the gain accuracy specification will be degraded from 0.15 dB to a typical value of 0.25 dB. For more information, refer to "Calibration, IF Attenuators" Detailed Operating Instruction.

Table 3-9. Special Function to HP-IB Code (4 of 7)

Special Function		HP-IB Code	Description
Name	Code*	HP-IB	
Interpolated Measurements	36.4	FF	Fine Tuning Calibration at Current Frequency
	39.0	DG	Disable Interpolated Measurements in Modes 1.5 through 1.9
	39.1	EG	Enable Interpolated Measurements in Modes 1.5 through 1.9
HP-IB and SIB Addresses	40.0	none	Display and Enter Noise Figure Meter Address
	40.1	EA	Display and Enter System LO Address
	40.2	HT	Display and Enter Noise Figure Test Set SIB Address
	40.3	HP	Display and Enter Plotter SIB Address
	40.4	HS	Display and Enter SIB Address
	40.5	HC	Display and Enter Pass Control SIB Address
	40.6	PT	Display and Enter the SIB Address of the Pass Through Device on the SIB
	40.7	VP	Display the Pass Through Address of the Noise Figure Meter
System LO Programs	41.0	J0	HP 8350B Sweep Oscillator
	41.2	J2	HP 8671B/8672A Syn. Signal Generator
	41.3	J3	HP 8673B/C/G Syn. Signal Generator
	41.4	J4	HP 8340B/8341B Sweep Oscillator
	41.5	J5	Custom Local Oscillator
System LO Commands	42.0	AC	Auxiliary Commands
	42.1	PS	CW Prefix and Suffix
	42.2	TM	Settling Time in ms
	42.3	MN	Minimum Frequency in MHz
	42.4	MX	Maximum Frequency in MHz
	42.5	PL	System Local Oscillator Power Level
	42.6	PC	Power Prefix and Suffix for Custom Local Oscillator
	42.7	FC	Frequency Prefix and Suffix for Custom Local Oscillator
HP-IB Data Output Selection	43.0	H0	NOISE FIGURE Only
	43.1	H1	Frequency (left display), INSERTION GAIN, NOISE FIGURE
	43.2	H2	Frequency, Calibration Data (GmKBm) and Second Stage Temperature are Output over HP-IB during Calibration.
Service Request	44.0	Q0	Disable SRQ Capability (clears all enabled conditions)
	44.1	Q1	Enable Data Ready to cause an SRQ
	44.2	Q2	Enable Cal Complete to cause an SRQ
	44.3	Q3	Enable HP-IB Code Error to cause an SRQ
	44.4	Q4	Enable SRQ on the SIB to Cause an SRQ
	44.5	Q5	Enable Noise Figure Meter Received Control on the SIB to Cause an SRQ

*Most Special Functions can be programmed using either the code number followed by SP or the HP-IB Code.

Table 3-9. Special Function to HP-IB Code (5 of 7)

Special Function		HP-IB Code	Description
Name	Code*	HP-IB	
	44.6	Q6	Enable Instrument Error to cause an SRQ
	44.7	RM	Enable all desired Conditions on the Status Byte to Cause an SRQ
	44.8	Q8	Enable Extended Status Byte to Cause an SRQ
	44.9	RE	Enable all desired Conditions on the Extended Status Byte
Noise Figure Test Set Control	45.0	TE	Enable Noise Figure Test Set in Modes 1.5 through 1.9
	45.1	TS	Enable Noise Figure Test Set in all Modes
	45.2	TD	Disable Noise Figure Test Set in all Modes
System Local Oscillator Control	46.0	LE	Enable System Local Oscillator on the SIB
	46.1	LD	Disable System Local Oscillator on the SIB
Plotter Control	47.0	PI	Plotter is on the SIB
	47.1	PM	Enable Plot Data to be read on the HP-IB
HP 8757 Scalar Analyzer Control	47.2	ZP	Enable plot to HP 8757 Scalar Analyzer
	47.3	ZQ	Disable plot to HP 8757 Scalar Analyzer
	47.4	ZR	Display and enter HP 8757 Scalar Analyzer System Interface Bus Address
	47.5	ZS	Number of measurement frequencies per HP 8757 Scalar Analyzer display refresh
	48.0	SC	Enable Noise Figure Meter as System Controller on the SIB
SIB Controller	48.1	NC	Disable Noise Figure Meter as System Controller on the SIB
	48.2	DC	Disable Error 48 (E48)
Sharing Control on the SIB	49.0	DP	Disable Auto Pass Control
	49.1	EP	Enable Auto Pass Control
	49.2	CR	Enable Noise Figure Meter to Release Control of the SIB
	49.3	CT	Enable Noise Figure Meter to Take Control of the SIB
	49.4	SB	Enable Noise Figure Meter to perform a Serial Poll on the SIB
	49.5	DD	Perform a Selective Device Clear of the Pass Through Device on the SIB.
	49.6	DS	Perform a Device Clear on the SIB, if the Noise Figure Meter is the Active Controller.
Special Function Catalog	49.7	IS	Perform an Interface Clear on the SIB, if the Noise Figure Meter is the System Controller.
	50.0	G0	Scan Special Function Catalog Lines
	50.1	G1	Line 1 Status
	50.2	G2	Line 2 Status
	50.3	G3	Line 3 Status
	50.4	G4	Line 4 Status
	50.5	G5	Line 5 Status
	50.6	G6	Line 6 Status
	50.7	G7	Line 7 Status
	50.8	G8	Line 8 Status

*Most Special Functions can be programmed using either the code number followed by SP or the HP-IB Code.

Table 3-9. Special Function to HP-IB Code (6 of 7)

Special Function		HP-IB Code	Description
Name	Code*	HP-IB	
RF Attenuation Selection	60.0	R0	Auto
	60.1	R1	+20 dB
	60.2	R2	+10 dB
	60.3	R3	0 dB
	60.4	R4	-10 dB
	60.5	R5	-20 dB
	60.6	R6	-30 dB
Display RF Attenuator Settings	61.0	SR	Display RF Attenuators
RF Attenuator Hold	62.0	RH	RF Attenuators are held in the configuration that exists when Special Function 62.0 is activated.
Individual RF Attenuator Selection	63.0	Z0	Select RF Thru Path
	63.1	Z1	Select 10 dB Pad No. 1
	63.2	Z2	Select 20 dB Input Amplifier
	63.4	Z4	Select 10 dB Pad No. 2
	63.5	Z5	Select 10 dB Pad No. 3
Noise Figure Test Set YIG Filter	64.0	CP	Enable Coarse Tuning Calibration
Coarse Tuning Calibration	64.1	CU	Select Upper Frequency of Noise Figure Test Set
IF Attenuation Selection	70.0	I0	Auto
	70.1	I1	0 dB
	70.2	I2	5 dB
	70.3	I3	10 dB
	70.4	I4	15 dB
	70.5	I5	20 dB
	70.6	I6	25 dB
	70.7	I7	30 dB
	70.8	I8	35 dB
Display IF Attenuator Settings	71.0	SI	Display IF Attenuators
IF Attenuator Hold	72.0	IH	IF Attenuators are held in the configuration that exists when Special Function 72.0 is activated.
Voltmeter Mode	80.0	VC	Noise Source Off
	81.0	VH	Noise Source On
Recorder Test Functions	82.0	A7	Enable Recorder Test
	82.1	XV	X-Axis Test
	82.2	YV	Y-Axis Test
Keyboard Test	90.0	KY	Display Key Codes
	90.1	K1	Key Test — Row 1
	90.2	K2	Key Test — Row 2
	90.3	K3	Key Test — Row 3
	90.4	K4	Key Test — Row 4
	90.5	K5	Key Test — Row 5
	90.6	K6	Key Test — Row 6
	90.7	K7	Key Test — Row 7
	90.8	K8	Key Test — Row 8
Display Test	91.0	DT	Enable Display Test
0 MHz Hold	92.0	U0	Off
	92.1	U1	On
	93.0	AI	Sets the Address for Modification or Inspection and Enables Auto-Increment Mode.

*Most Special Functions can be programmed using either the code number followed by SP or the HP-IB Code.

Table 3-9. Special Function to HP-IB Code (7 of 7)

Special Function		HP-IB Code	Description
Name	Code*	HP-IB	
	93.1	AD	Sets the Address for Modification or Inspection and Disables Auto-Increment Mode.
	93.2	MB	Selects Modification or Inspection of a Byte in RAM or Inspection of a Byte in ROM.
	93.3	MW	Selects Modification or Inspection of a Word in RAM or Inspection of a Word in ROM.
	93.4	MF	Selects Modification or Inspection of a Floating Point Value in RAM or Inspection of a Floating Point Value in ROM.
Noise Figure Meter YIG Filter Tuning Functions	94.1	—	Disable Hysteresis Calibration when Frequency is Changed.
	94.2	EH	Enable Hysteresis Calibration when Frequency is Changed.
	94.3	—	YIG DAC is not Updated when Frequency is Changed.
	94.4	UY	YIG DAC is Updated when Frequency is Changed.
Default ENR	95.6	ND	Sets all ENR Values to 15.20 dB and Noise Source ID No. to 00000
Debug Oscilloscope Plots	97.1	Y9	Enables Debug Oscilloscope Plots
	97.2	Y8	Disables Debug Oscilloscope Plots
Noise Figure Test Set Protection	97.3	DA	Disable Auto Sweep Abort (See Error E102)
Last Error	99.1	ER	Recalls Last Error Issued.
Software Date	99.9	SD	Displays Current Software Date

*Most Special Functions can be programmed using either the code number followed by SP or the HP-IB Code.

Table 3-10. Front Panel Keys to HP-IB Code Summary

Parameter	HP-IB Code	Parameter	HP-IB Code
	HP-IB		HP-IB
AUTO	W1	PRESET	PR
CALIBRATE	CA	RECALL	RC
DECREASE	DE	SEQ	SQ
ENR	NR	SINGLE	W2
ENTER	EN	SPECIAL FUNCTION	SP
FREQ INCR	FN	START FREQ	FA
▼	DN	STEP SIZE	SS
▲	UP	STOP FREQ	FB
FREQUENCY	FR	STORE	ST
GRAPHIC SCALE		Sweep and Calibrate Off (must be used to turn these functions off over the HP-IB)	W0
GAIN MAX	GU		
GAIN MIN	GL		
NOISE MAX	NU		
NOISE MIN	NL		
INCREASE	IN		
NOISE FIGURE (UNCORRECTED)	M1		
NOISE FIGURE AND GAIN (CORRECTED)	M2		

Table 3-11. Commonly Used Code Conversions

ASCII	Binary	Octal	Decimal	Hexa-decimal
NUL	00 000 000	000	0	00
SOH	00 000 001	001	1	01
STX	00 000 010	002	2	02
ETX	00 000 011	003	3	03
EOT	00 000 100	004	4	04
ENQ	00 000 101	005	5	05
ACK	00 000 110	006	6	06
BEL	00 000 111	007	7	07
BS	00 001 000	010	8	08
HT	00 001 001	011	9	09
LF	00 001 010	012	10	0A
VT	00 001 011	013	11	0B
FF	00 001 100	014	12	0C
CR	00 001 101	015	13	0D
SO	00 001 110	016	14	0E
SI	00 001 111	017	15	0F
DLE	00 010 000	020	16	10
DC1	00 010 001	021	17	11
DC2	00 010 010	022	18	12
DC3	00 010 011	023	19	13
DC4	00 010 100	024	20	14
NAK	00 010 101	025	21	15
SYN	00 010 110	026	22	16
ETB	00 010 111	027	23	17
CAN	00 011 000	030	24	18
EM	00 011 001	031	25	19
SUB	00 011 010	032	26	1A
ESC	00 011 011	033	27	1B
FS	00 011 100	034	28	1C
GS	00 011 101	035	29	1D
RS	00 011 110	036	30	1E
US	00 011 111	037	31	1F
SP	00 100 000	040	32	20
!	00 100 001	041	33	21
"	00 100 010	042	34	22
#	00 100 011	043	35	23
\$	00 100 100	044	36	24
%	00 100 101	045	37	25
&	00 100 110	046	38	26
'	00 100 111	047	39	27
(00 101 000	050	40	28
)	00 101 001	051	41	29
*	00 101 010	052	42	2A
+	00 101 011	053	43	2B
,	00 101 100	054	44	2C
-	00 101 101	055	45	2D
.	00 101 110	056	46	2E
/	00 101 111	057	47	2F
0	00 110 000	060	48	30
1	00 110 001	061	49	31
2	00 110 010	062	50	32
3	00 110 011	063	51	33
4	00 110 100	064	52	34
5	00 110 101	065	53	35
6	00 110 110	066	54	36
7	00 110 111	067	55	37
8	00 111 000	070	56	38
9	00 111 001	071	57	39
:	00 111 010	072	58	3A
;	00 111 011	073	59	3B
<	00 111 100	074	60	3C
=	00 111 101	075	61	3D
>	00 111 110	076	62	3E
?	00 111 111	077	63	3F

ASCII	Binary	Octal	Decimal	Hexa-decimal
@	01 000 000	100	64	40
A	01 000 001	101	65	41
B	01 000 010	102	66	42
C	01 000 011	103	67	43
D	01 000 100	104	68	44
E	01 000 101	105	69	45
F	01 000 110	106	70	46
G	01 000 111	107	71	47
H	01 001 000	110	72	48
I	01 001 001	111	73	49
J	01 001 010	112	74	4A
K	01 001 011	113	75	4B
L	01 001 100	114	76	4C
M	01 001 101	115	77	4D
N	01 001 110	116	78	4E
O	01 001 111	117	79	4F
P	01 010 000	120	80	50
Q	01 010 001	121	81	51
R	01 010 010	122	82	52
S	01 010 011	123	83	53
T	01 010 100	124	84	54
U	01 010 101	125	85	55
V	01 010 110	126	86	56
W	01 010 111	127	87	57
X	01 011 000	130	88	58
Y	01 011 001	131	89	59
Z	01 011 010	132	90	5A
[01 011 011	133	91	5B
\	01 011 100	134	92	5C
^	01 011 101	135	93	5D
^	01 011 110	136	94	5E
_	01 011 111	137	95	5F
`	01 100 000	140	96	60
a	01 100 001	141	97	61
b	01 100 010	142	98	62
c	01 100 011	143	99	63
d	01 100 100	144	100	64
e	01 100 101	145	101	65
f	01 100 110	146	102	66
g	01 100 111	147	103	67
h	01 101 000	150	104	68
i	01 101 001	151	105	69
j	01 101 010	152	106	6A
k	01 101 011	153	107	6B
l	01 101 100	154	108	6C
m	01 101 101	155	109	6D
n	01 101 110	156	110	6E
o	01 101 111	157	111	6F
p	01 110 000	160	112	70
q	01 110 001	161	113	71
r	01 110 010	162	114	72
s	01 110 011	163	115	73
t	01 110 100	164	116	74
u	01 110 101	165	117	75
v	01 110 110	166	118	76
w	01 110 111	167	119	77
x	01 111 000	170	120	78
y	01 111 001	171	121	79
z	01 111 010	172	122	7A
{	01 111 011	173	123	7B
:	01 111 100	174	124	7C
}	01 111 101	175	125	7D
~	01 111 110	176	126	7E
DEL	01 111 111	177	127	7F

Calibrate

(Includes Special Function 39)

Description

Special Functions 39.0 and 39.1 are ONLY used with Measurement Modes 1.5 through 1.9. Special Function 39.0 does not allow interpolated measurements between calibrated points. Special Function 39.1 does allow interpolated measurements between calibrated points.

Pressing the CALIBRATE key initiates a calibration of the instrument and any equipment that is currently connected to the INPUT. First a frequency calibration is performed and then the noise figure is measured at each selected calibration point. The calibration data obtained is used to measure gain and to perform the “second stage correction” computations needed to make a CORRECTED NOISE FIGURE AND GAIN measurement. The calibration points are the START FREQ setting, the STOP FREQ setting, and the frequency steps determined by the setting of STEP SIZE. Refer to the Sweep Detailed Operating Instruction for additional information on these keys. During calibration, each specified frequency in the selected range is calibrated at three input gain settings as selected by Special Function 32. The default gain settings are +20, +10 and 0 dB. In Measurement Modes 1.0 through 1.4, the calibration data is automatically interpolated between the calibrated points when it is used for a gain measurement and second stage correction. Therefore, it is not necessary to calibrate at every frequency that is to be measured. However, Hewlett-Packard recommends that each measured point should be a calibrated point. In Measurement Modes 1.5 through 1.9, the default (Special Function 39.0) is set, which does not allow interpolation between calibrated points. However, the calibration data can be interpolated between calibrated points by using Special Function 39.1.

If Special Function 39.0 is active and interpolation is attempted in Measurement Modes 1.5 through 1.9, error code E21 (Frequency Out of Calibrated Range or not a calibrated point) is generated. Also, if a corrected measurement is attempted at a frequency less than the START FREQ setting or more than the STOP FREQ setting of the calibration run, error code E21 is displayed.

During a calibration, the calibration data can be gathered over the Hewlett-Packard Interface Bus (HP-IB). For more information, refer to the “Comments” section at the end of this instruction.

Specific calibration setups and procedures are contained in the “Detailed Operating Instructions” for Measurement Modes 1.0 through 1.9.

WARNING

The local oscillator power must be selected for the type of HP 8971B/C in use.

An HP 8971B requires +6 dBm, an HP 8971C standard or Option 002 requires +10 dBm at 26.5 GHz (+8 dBm is adequate below 22 GHz), and an HP 8971C Option 001 should have only +1 dBm. Use special function 42.5 to change the local oscillator power if necessary.

Procedure

To initiate a calibration sequence, press CALIBRATE. The message “Press Cal” will be displayed. Press CALIBRATE again. Pressing the CALIBRATE key twice ensures that the CALIBRATE key is not inadvertently pressed. To terminate calibration

Calibrate (cont'd)

(Includes Special Function 39)

Procedure (cont'd)

Front Panel Key	Program Code 	Stored in Continuous Memory	Can Be Stored and Recalled	Preset (and HP-IB Clear) Conditions	Special Function 0.9 Conditions
CALIBRATE	CA	N	N	Off	Off

Table categories are described in the Preset Conditions and Power-Up Sequence Detailed Operating Instruction.

Special Function		Program Code 	Lights Special ¹ Function Key	Stored in Continuous Memory	Can be Stored and Recalled	Special Function 0.0 Conditions	Preset (and HP-IB Clear) Conditions	Special Function 0.9 Conditions
Description	Code							
Disables interpolated measurements in Measurement Modes 1.5 through 1.9	39.0	DG or 39.0 SP	N	Y	N	On	On	On
Enables interpolated measurements in Measurement Modes 1.5 through 1.9	39.1	EG or 39.1 SP	N	Y	N	Off	Off	Off

¹ Table categories are described in the Preset Conditions and Power-Up Sequence Detailed Operating Instruction.
N = No, Y = Yes, NC = No Change

Example

To initiate calibration at the existing SWEEP function settings:

LOCAL (keystrokes)	
(program codes)	CA

Calibrate (cont'd)

(Includes Special Function 39)

Procedure (cont'd)

before it is complete, press CALIBRATE again. Pressing PRESET also terminates the calibration sequence.

To select Special Function 39.0 or 39.1, enter the code desired and press the SPECIAL FUNCTION key.

Program Codes HP-IB

CA is the program code for the CALIBRATE key. The calibration sequence can not be toggled on and off over the HP-IB. Instead, successive CA codes cause the calibration to be restarted. To terminate calibration prior to completion, use the Sweep Stop command (W0). Refer to the Procedure for other HP-IB codes.

Indications

The CALIBRATE LED lights and remains lit until the calibration is complete. During frequency calibration, the INSERTION GAIN display shows "Fr" and the NOISE FIGURE display shows "CAL".

During second stage calibration, the left display indicates each tuned frequency and the NOISE FIGURE display indicates the noise figure at that frequency. The frequency range and step size are controlled by the SWEEP keys.

When calibration is completed, the instrument resumes making the measurement that was active when CALIBRATE was pressed. However, if the instrument was sweeping (either in AUTO or SINGLE) it does not resume sweeping. Instead, it performs the previously selected measurement at the frequency it was tuned to when CALIBRATE was pressed.

Comments

The maximum number of frequency points that can be calibrated is 181 for the Noise Figure Meter (range 10 MHz to 1600 MHz; 2047 MHz for opt 020) or the Noise Figure Measurement System (range 10 MHz to 26500 MHz). For the Noise Figure Measurement System, this is approximately 150 MHz steps for the full range.

When a calibration is done in Measurement Modes 1.5 through 1.9 and Special Function 36.0 is active, the Noise Figure Test Set is calibrated before the Noise Figure Measurement System (Noise Figure Meter, Noise Figure Test Set and System Local Oscillator) calibration. "8971 CAL" is displayed, on the Noise Figure Meter, during the Noise Figure Test Set calibration. For more information, refer to the Noise Figure Test Set YIG Filter Calibration Detailed Operating Instruction.

During calibration, all of the front panel keys except LOCAL, PRESET, and CALIBRATE are disabled.

If LOCAL is pressed during calibration, the instrument returns to local control (if it was in remote, and the Local Lockout command was not in effect). Calibration is not interrupted by the LOCAL command.

Pressing PRESET or CALIBRATE terminates the calibration function. However, PRESET also resets the entire instrument to a specified set of conditions (refer to the Preset Conditions and Power-Up Sequence Detailed Operating Instruction). If either of these keys are pressed during the frequency calibration portion of the sequence (that

Calibrate (cont'd) **(Includes Special Function 39)**

Comments (cont'd)

is, "Fr CAL" is being displayed), calibration is not terminated. These commands cannot be used until the frequency calibration is completed.

The calibration data cannot be stored using the STORE key and it is not retained when the instrument is turned off. Therefore, it is necessary to calibrate the instrument each time power is turned on.

The most accurate calibration can be obtained after a warm-up of at least one hour. The best HP 8971C thermal equilibrium can be obtained if the instrument is allowed to dwell at a frequency 0.7 times the maximum tuning frequency, or if the noise figure meter is stepped through its frequency list prior to calibration.

The HP 8971C will give a warning if the ambient temperature changes greater than 5°C. If the ambient temperature is measured as part of a measurement program at calibration, and sampled at intervals, then a change in ambient temperature can be used to warn the operator that recalibration is suggested to obtain greater accuracy. See program example.

If smoothing (averaging) is used during calibration, the arithmetic averaging algorithm is used. Refer to the Smoothing (Averaging) Detailed Operating Instruction for a detailed discussion of the averaging techniques used by the instrument. A smoothing factor of 4 or 8 is recommended for the most accurate calibration. Note that once calibration is initiated, the SMOOTHING keys are disabled and the averaging factor cannot be changed during the calibration sequence.

If an external controller is being used to control both the Noise Figure Meter and the system local oscillator or the Noise Figure Measurement System and the user controlled local oscillator, the calibration sequence must be stepped using the HP-IB commands T1 (Trigger hold) and T2 (Trigger execute) after the local oscillator has been moved to each new frequency. Once the HP-IB command for calibration (CA) is issued, the T2 mnemonic for trigger execute must be used. The Noise Figure Meter will ignore the alternate HP-IB code of 30.2SP. Refer to the Trigger Selection Detailed Operating Instruction for additional triggering information.

It is assumed that the triggered calibration is being performed as a part of the procedure in the Comments section of the Detailed Operating Instructions for Measurement Modes 1.0 through 1.9. All Measurement Modes require a triggered calibration sequence. Therefore, the preliminary steps such as selecting Special Function 4.0 will have already been performed. The following general conditions must be observed when using an external controller to perform a triggered calibration:

- a. Remove the device under test (DUT) from the measurement system.
- b. Set the Noise Figure Meter to trigger hold (T1) mode.
- c. Set the Noise Figure Meter's calibrate function on (HP-IB code is CA).

Calibrate (cont'd)

(Includes Special Function 39)

Program Example To Check Ambient Temperature

```

10 COM /Check_temp/ Pass_thru, Temp_spec, Init_amb_temp
20 Nfm=708 ! Noise Figure Meter Address.
30 Nfts=710 ! 8971C Address.
40 Controller=700 ! Controller Card * 100.
50 Pass_thru=BINOR(Nfm,1) ! Pass Thru Address to 8971C
60 Temp_spec=2 ! Tight Temperature Spec
70 Temp_time=5*60 ! Time Between Measurements of Temp.
80 OUTPUT Nfm;"PT ";Nfts-Controller;" EN"! Pass Thru Address
90 OUTPUT Pass_thru;"CAD 6" ! Request Ambient Temperature.
100 ENTER Pass_thru;Ambient_a_d ! Get Temperature.
110 Init_amb_temp=Ambient_a_d*.346 ! Convert A to D Value to Deg C
120 PRINT Init_amb_temp ! Initial Temp
130 !
140 ON CYCLE Temp_time CALL Check_temp
150 Cycle_thru; !
160 PRINT "WORKING"
170 !
180 !
190 ! YOUR TEST GOES HERE
200 !
210 !
220 !
230 GOTO Cycle_thru
240 END
250 !
260 SUB Check_temp! This Sub Checks The Ambient Temp
270 COM /Check_temp/ Pass_thru, Temp_spec, Init_amb_temp
280 OUTPUT Pass_thru;"CADX 6" ! Request Ambient Temperature.
290 ENTER Pass_thru;Ambient_a_d ! Get Temperature.
300 Ambient_temp=Ambient_a_d*.346 ! Convert A to D Value to Deg C
310 IF ABS(Init_amb_temp-Ambient_temp)>Temp_spec THEN
320 DISP "MIGHT BE TIME TO RECALIBRATE"
330 END IF
340 SUBEND

```

Comments (cont'd)

- d. Set the LO to the appropriate frequency. Refer to the LO's operating manual for the required HP-IB codes. Allow sufficient settling time for the output of the LO to stabilize.
- e. Trigger a measurement using the HP-IB code T2. Do not use the alternate HP-IB code 30.2SP for it will be ignored.
- f. A method must be determined when to step to a new frequency and read the noise figure results. This read operation cannot be completed until the new data is ready. It is possible to write an SRQ interrupt routine on the Data Ready status bit. Refer to "Enabling the Service Request Condition", paragraph 3-30.

Calibrate (cont'd)

(Includes Special Function 39)

Comments (cont'd)

- g. Continue to loop through steps d, e, and f. A method for determining when the calibration is complete must be programmed into the external controller. One method is to compare the frequency that is sent to the LO with the stop frequency programmed into the Noise Figure Meter and terminate the program after the third measurement in which they are equal. It is also possible to write an SRQ interrupt routine on the Calibration Complete SRQ. Refer to "Enabling the Service Request Condition", paragraph 3-30.

Calibration data can be collected at the time the calibrate command is executed. This feature is useful for comparing calibrations, to see how the Noise Figure Meter is performing. The controller can command the Noise Figure Meter to send both the gain reference (GkB) and second stage temperature, using the HP-IB command H2. H2 will cause the Noise Figure Meter to output the following string:

+FFFFFFE+06,SCCCCE+XX,STTTTTE+YY (CRLF)

Where FFFFFF is the calibration frequency, STTTTT is the sign followed by the second stage temperature value and SCCCCC is the sign followed by the calibration data of GkB for the point being sent. The exponents are shown above as XX and YY. The string is followed with carriage return and line feed.

The equations for GkB and the second stage temperature are given below:

$$GkB = \frac{P_{(hot)} - P_{(cold)}}{T_{(hot)} - T_{(cold)}}$$

$$Second\ Stage\ Temperature = \frac{T_{(hot)} - [(T_{(cold)})(Y)]}{Y - 1}$$

$$Y = \frac{P_{(hot)}}{P_{(cold)}}$$

$P_{(hot)}$ is the power (in joules/second) for a hot (noise source on) measurement during calibration. $P_{(cold)}$ is the power (in joules/second) for a cold (noise source off) measurement during calibration. $T_{(hot)}$ is the temperature (in Kelvin) for a hot measurement from the ENR (Excess Noise Ratio) tables. $T_{(cold)}$ is the temperature (in Kelvin) for a cold measurement set with Special Function 6.0.

The same general conditions (steps a through g), as described earlier, also apply when performing a triggered calibration and outputting the data to the controller. The exception is that the command H2 must be used.

The following is an example of a program that will perform a triggered calibration and output the calibration data, in Measurement Modes 1.0 or 1.5:

NOTE

This program was written in BASIC language 3.0 using the HP 9000 Series 200 Model 236 computer.

Calibrate (cont'd) (Includes Special Function 39)

Program Example For Triggered Calibration

```

10 DIM A$[80],T$[10]
20 PRINTER IS CRT
30 Nfm=708                !Noise Figure Meter address.
40 Start=20              !Start Frequency
50 Stop=100              !Stop Frequency
60 Step=20               !Step Size
70 OUTPUT Nfm;"H2"      !Output second stage temperature and
                        !GkB during calibration
80 OUTPUT Nfm;"T1"      !Trigger Hold
90 OUTPUT Nfm;"FA";Start;"EN FB";Stop;"EN"!Start and stop frequencies
100 OUTPUT Nfm;"SS";Step;"EN"    !Step Size
110 INPUT "MAKE SURE THE NOISE FIGURE METER IS SETUP FOR A CALIBRATION AND PRESS 'ENTER'",A
120 !
130 !
140 !NOW BEGIN TAKING DATA FROM THE CALIBRATION
150 !
160 OUTPUT Nfm;"RM 2 EN"      !Setup calibration complete SRQ
170 OUTPUT Nfm;"RS"          !Reset Noise Figure Meter Status Byte
180 OUTPUT Nfm;"CA"          !Start the calibration
190 Loop:                    !Loop to do all measurements
200 !IN MEASUREMENT MODES 1.6 THROUGH 1.9,
210 !APPROPRIATE COMMANDS TO CONTROL THE USER
220 !CONTROLLED LOCAL OSCILLATOR SHOULD BE ADDED HERE
230 OUTPUT Nfm;"T2"          !Trigger a measurement
240 ENTER Nfm;Freq,GkB,Tem   !Get the calibration frequency,
                        !gain reference and second stage
                        !temperature
250 PRINT "FREQ, GkB, Tem =";Freq," ",GkB," ",Tem
260 S=SPOLL (Nfm)           !Get Noise Figure Meter Status Byte
270 IF BIT (S,1)=0 THEN GOTO Loop    !Continue until done
280 !
290 PRINT "DONE."
300 !
310 END

```

Calibrate (cont'd)

(Includes Special Function 39)

Comments (cont'd)

If any of the 60 or 70 series of Special Functions (except 60.0 and 70.0) are active, the calibration sequence does not override them. Therefore, to calibrate on one range only, use any of these Special Functions except 60.0 or 70.0. If any of these Special Functions are inadvertently left active the calibration sequence may not cover the expected gain range.

Any loss compensation entered by Special Function 34 is ignored during the calibration sequence.

Related Sections

Calibration, Frequency

Calibration, Input Gain Selection

Measurement Modes 1.0 through 1.9

Noise Figure (Uncorrected) and Noise Figure and Gain (Corrected)

Sweep

Trigger Selection

Calibration, Frequency (Special Function 31)

Description

Frequency Calibration is performed to ensure the accuracy of the displayed tuned frequency. During frequency calibration, the instrument's first local oscillator (the YIG oscillator) is tuned to the first IF (2050 MHz; 3900 MHz opt 020). Since the first mixer is not perfectly balanced, some of the first local oscillator power is fed through to the first IF. This signal is mixed down to the third IF. It is then detected by a special narrow-band detector (approx. 100kHz wide). Unless Special Function 60.1 - 60.6 or 62 is selected, the RF input attenuators are switched in during frequency Calibration to allow the LO feed thru signal to dominate.

The YIG oscillator is then stepped through the narrow-band detector's pass band using a special fine tune digital-to-analog converter (DAC). When the peak output is detected, the YIG oscillator is tuned to the first IF (2050 MHz; 3900 MHz opt 020). This IF corresponds to 0 MHz on the front-panel frequency display. The fine tune DAC is held at this value. This correction value is then used when the YIG oscillator is tuned in response to subsequent tuning changes

Frequency calibration is initiated by the following:

- a. The LINE switch is pressed to apply power to the instrument.
- b. The PRESET key is pressed or the CALIBRATE key is pressed if Special Function 31.0 is active.
- c. Special Function 31 is used to initiate and control frequency calibration.

Completion of Frequency Calibration does not set the CALIBRATION COMPLETE bit of the HP-IB status byte. That bit is used only for RF calibration.

Special Function 31 is defined as follows:

- a. 31.0—Selects the automatic frequency calibration mode. In addition to the initial frequency calibration described previously, a frequency calibration is automatically initiated 15 minutes after power on, 30 minutes later, 1 hour later, 2 hours later, and then every 2 hours until the instrument is turned off or a different 31 Special Function is entered. This mode is the default condition. If the RF input attenuators are locked (special function 60.1-60.6 or 62), frequency calibration may fail due to excess noise power from the device under test. This will result in an E18 (Frequency Calibration failure) error. If this should occur, automatic frequency calibration can be disabled, and periodic manual calibration (31.2 special function) can be substituted. Note, however, that the input attenuators should be unlocked (60.0 special function) prior to executing the calibration.
- b. 31.1—Disables the frequency calibration. In this mode, frequency calibration is still done if the PRESET key is pressed. However, frequency calibration is not initiated periodically as described in 31.0.
- c. 31.2—Initiates a frequency calibration immediately. After that frequency calibration, the operation returns to the mode active when 31.2 was entered. If 31.1 was active, it remains active after the frequency calibration is done.

Procedure

Frequency calibration is performed as a part of PRESET. Frequency calibration can also be done when the CALIBRATE key is pressed and Special Function 31.0 is active. In addition, the frequency calibration can be performed or disabled by keying in the corresponding Special Function code and then pressing the SPECIAL FUNCTION key.

Calibration Frequency (cont'd)

(Special Function 31)

Procedure (cont'd)

Special Function		Program Code HP-IB	Lights Special ¹ Function Key	Stored in Continuous Memory	Can be Stored and Recalled	Special Function 0.0 Conditions	Preset (and HP-IB Clear) Conditions	Special Function 0.9 Conditions
Description	Code							
Automatic Frequency Calibration	31.0	Y0 or 31.0SP	N	N	N	On	On	On
Disable Frequency Calibration	31.1	Y1 or 31.1SP	N	N	N	Off	Off	Off
Perform One Frequency Calibration	31.2	Y2 or 31.2SP	N	N	N	Off	Off	Off

¹Table categories are explained in the Special Functions Detailed Operating Instruction.

Example

To select the Disable Frequency Calibration Mode:

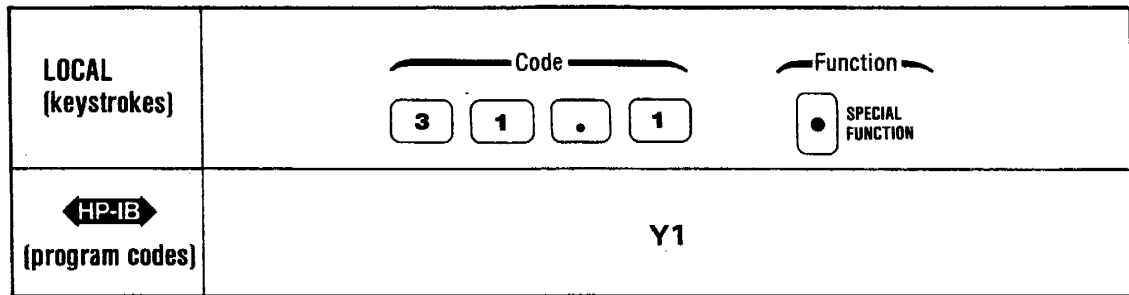

Program Codes



For HP-IB codes, refer to Procedure above.

Indications

The INSERTION GAIN and NOISE FIGURE displays are not affected by 31.0 and 31.1. If 31.2 is entered, the INSERTION GAIN display shows “Fr” and NOISE FIGURE display shows “CAL” until the frequency calibration is completed.

Related Sections

- Calibrate
- Preset Conditions and Power-Up Sequence
- Special Functions

Calibration, IF Attenuators (Special Function 33.1)

READ THE FOLLOWING NOTE BEFORE CALIBRATING THE IF ATTENUATORS USING SPECIAL FUNCTION 33.1

NOTE

Using Special Function 33.1, to calibrate the IF attenuators, will reduce the gain instrumentation uncertainty specification to a typical value of ± 0.25 dB.

If error code E26 (IF calibration needed) is valid, the following methods can be used to calibrate the IF attenuators, while maintaining a gain instrumentation uncertainty specification of ± 0.15 dB:

- *If the Noise Figure Meter is due for its annual calibration, refer to Section IV, Performance Tests. Before starting the tests, use Special Function 33.1, with an HP 346 B/C Noise Source, to clear error E26. OR, send the Noise Figure Meter to the nearest Hewlett-Packard service center for calibration.*
- *If the Noise Figure Meter is not due for its annual calibration, enter the IF attenuator calibration data that should have been recorded in Section IV (Table 4-1), at the time of installation (see Section II). Enter the data using the "Entering IF Attenuator Values" section of the Gain Measurement Uncertainty Performance Test in Section IV. This method maintains the gain instrumentation uncertainty specification of ± 0.15 dB.*
- *Perform the "IF Attenuator Calibration" section of the Gain Measurement Uncertainty Performance Test in Section IV. This method maintains the gain instrumentation uncertainty specification of ± 0.15 dB.*
- *Use Special Function 33.1 to perform the IF attenuator calibration. If Special Function 33.1 is used, the gain instrumentation uncertainty specification will be degraded from ± 0.15 dB to a typical value of ± 0.25 dB. Because of this degradation, Hewlett-Packard recommends that one of the other methods be used to calibrate the IF attenuators.*

Calibration, IF Attenuators (cont'd)

(Special Function 33.1)

Description

Special Function 33.1 is used to calibrate the IF Attenuators. The HP 346 B/C noise source **MUST** be connected to the Noise Figure Meter. The Noise Figure Meter turns on the noise source and uses its own internal noise power detector to measure each IF attenuator. This data is used to correct the gain readings during gain measurement. After the IF attenuation calibration is completed, this data is stored in the instrument's continuous memory and is retained when power is removed. Completion of IF calibration does not set the CALIBRATION COMPLETE bit of the HP-IB status byte.

Procedure

To calibrate the IF Attenuators, connect the HP 346 B/C noise source to the instrument's INPUT connector, enter 33.1, and then press SPECIAL FUNCTION.

Special Function		Program Code 	Description	Lights Special ¹ Function Key	Stored in Continuous Memory	Can be Stored and Recalled	Special Function 0.0 Conditions	Preset (and HP-IB Clear) Conditions	Special Function 0.9 Conditions
Name	Code								
IF Attenuators Calibration	33.1	CI or 33.1SP	Calibrate IF Attenuators	N	Y	N	Off	Off	Off

¹ Table categories are explained in the Special Functions Detailed Operating Instruction.

Example

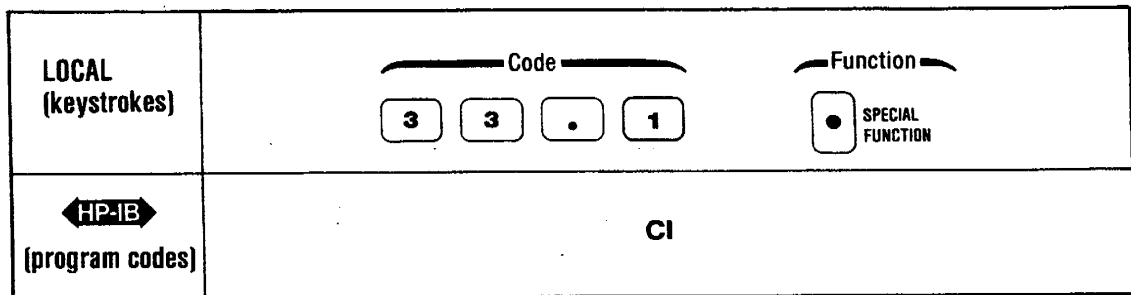

Program Codes



The HP-IB code for IF Attenuator Calibration is CI (or 33.1SP).

Indications

During calibration, the NOISE FIGURE display shows "IF CAL". IF Attenuator Calibration takes only a few seconds. If for any reason the IF Attenuator Calibration is not successfully completed, error E13 (IF Attenuator Calibration failed) is displayed.

Comments

Error code E26 is displayed if the IF Attenuator calibration data is not stored in the continuous memory. Error E26 always occurs after an error E80 (continuous memory failure). Therefore, an IF Attenuator calibration must always be performed after an error E80 has been cleared. Either an HP 346B or HP 346C Noise Source is needed for calibrating the IF attenuators. The HP 346A will work only with the addition of approximately 10 dB of gain (at the calibration frequency, of 30 MHz) between the Noise Source and the Noise Figure Meter INPUT connector.

Related Sections

Error Messages and Recovery
Special Functions

Calibration, Input Gain Selection (Special Function 32)

Description

The gain setting for calibration can be selected using Special Function 32. Calibration is performed from the start frequency to the stop frequency in steps of the specified step size. At each frequency, calibration is done at the three most sensitive RF attenuator gain settings (that is, +20,+10, and 0 dB). These settings are the default value for Special Function 32. Three other sets of gain settings can be selected using the special functions shown below. Selection of the gain settings to be calibrated depends upon the specific application. Selecting a calibration gain setting does not initiate a calibration sequence.

Procedure

To select an alternate gain setting for calibration, key in the corresponding Special Function code and then press the SPECIAL FUNCTION key.

Special Function		Program Code HP-IB	Lights Special ¹ Function Key	Stored in Continuous Memory	Can be Stored and Recalled	Special Function 0.0 Conditions	Preset (and HP-IB Clear) Conditions	Special Function 0.9 Conditions
Description	Code							
+20, +10, and 0 dB	32.0	C0 or 32.0SP	N	N	N	On	On	On
+10, 0, and -10 dB	32.1	C1 or 32.1SP	Y	N	N	Off	Off	Off
0, -10, and -20 dB	32.2	C2 or 32.2SP	Y	N	N	Off	Off	Off
-10, -20, and -30 dB	32.3	C3 or 32.3SP	Y	N	N	Off	Off	Off

¹ Table categories are explained in the Special Function Detailed Operation Instruction.

Example

To select +10, 0 and -10 dB as the gain settings for calibration:

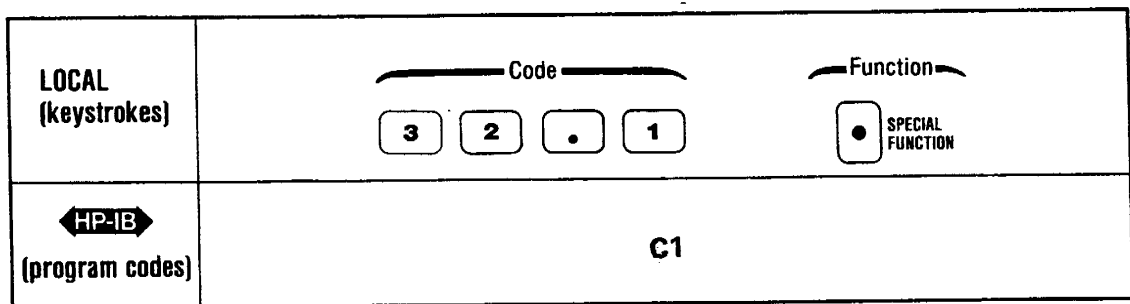

Program Codes



For HP-IB codes, refer to Procedure above.

Calibration, Input Gain Selection (cont'd)

(Special Function 32)

Comments

The gain settings, other than the default values, are used primarily when the Noise Figure Meter is calibrated with high gain external to the Noise Figure Meter.

If external gain is not being used during calibration and Special Function 32.1 is active, error code E27 (too much loss while calibrating) may be generated. If external gain is not being used during calibration and Special Function 32.2 or 32.3 is active, error code E27 will be generated.

DUTs in the specified range of -20 to $+40$ dB can be measured using Special Function 32.0.

Related Sections

Calibrate
Special Functions

Controller Capability of the Noise Figure Meter (Special Function 4)

Description The Noise Figure Meter can be used as a limited controller for an external device connected to the HP-IB connector. This capability is limited to operating in the Talk Only Mode (outputting data to a recording device such as a printer). The Noise Figure Meter can also be controlled by an external controller when Special Function 4.0 is active. Only one of the two capabilities can be active at any one time.

Procedure To select an HP-IB control capability, key in the corresponding Special Function code and then press the SPECIAL FUNCTION key.

Special Function		Program Code HP-IB	Lights Special ¹ Function Key	Stored in Con- tinuous Memory	Can be Stored and Recalled	Special Function 0.0 Conditions	Preset (and HP-IB Clear) Conditions	Special Function 0.9 Conditions
Description	Code							
Normal Talker and Listener Mode	4.0	None	N	Y	N	NC	NC	On
Refer to Special Function 46.0	4.1		—	—	—	—	—	—
Talk Only Mode	4.2	None	N	Y	N	NC	NC	Off

¹ Table categories are explained in the Special Function Detailed Operation Instruction.

Example To select the Talk Only Mode.

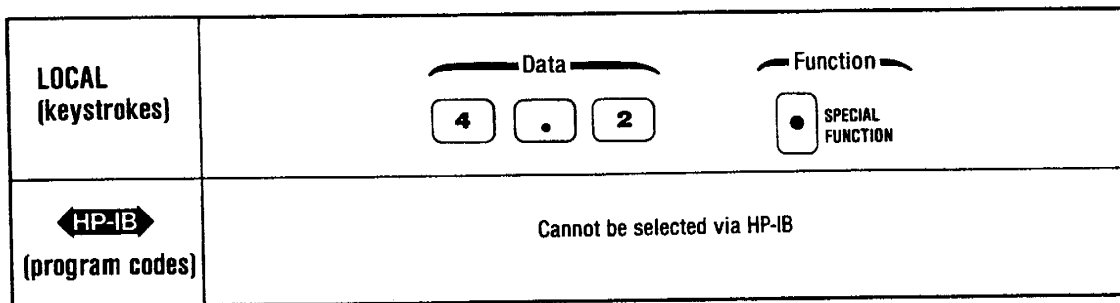

Indications When Special Function 4.2 is active, the HP-IB TALK annunciator lights.

Comments In the Talk Only Mode, the instrument continuously outputs data to a recording device that is in the Listen Only Mode. The data output format and content is controlled by Special Function 43. Refer to the HP-IB portion of this section for additional information on this Special Function.

Since the Noise Figure Meter has a second bus (System Interface Bus) to control the system LO, the Noise Figure Test Set and plotter, Special Function 4.1 is no longer used. Refer to Special Functions 45, 46 and 47.

Controller Capability of the Noise Figure Meter (cont'd) **(Special Function 4)**

**Comments
(cont'd)**

An external controller cannot be used when Special Function 4.2 is active.

The active function of Special Function 4 is not affected by PRESET, Special Function 0.0, or the LINE switch.

**Related
Sections**

Special Functions.
System Interface Bus Control

Data Output to Oscilloscopes, Recorders and Plotters

(Special Functions 7, 8, 20 through 25, and 47)

Description

The Noise Figure Meter can output analog data to an oscilloscope, an X-Y recorder, or a strip chart recorder. The Noise Figure Meter can only be used with an analog oscilloscope. Digital data can be output to a plotter on the Hewlett-Packard Interface Bus or the System Interface Bus. Digital data can also be output to the HP 8757 Scalar Analyzer on the System Interface Bus. However, only one of these devices can be used at a time. Since the setup procedures and operation are similar for all five devices, the operating information for all are covered in this operating instruction.

Normally it is simpler to perform a setup procedure using the oscilloscope and then do a plot or switch to a recorder mode (or use an oscilloscope camera) if a permanent record is required. In the example following the general procedure, this type of setup will be shown.

Procedure

To select one of the oscilloscope, recorder, or plotter output functions, key in the corresponding Special Function code and then press the SPECIAL FUNCTION key.

Special Function		Program Code HP-IB	Lights Special Function Key	Stored in Continuous Memory	Can be Stored and Recalled	Special Function 0.0 Conditions	Preset (and HP-IB Clear) Conditions	Special Function 0.9 Conditions
Description	Code							
Output to Oscilloscope								
Noise Figure and Gain	7.0	A0 or 7.0SP	N	Y	N	On	On	On
Test Pattern	7.1	A1 or 7.1SP	N	Y	N	Off	Off	Off
Noise Figure Only	7.2	A2 or 7.2SP	N	Y	N	Off	Off	Off
Gain Only	7.3	A3 or 7.3SP	N	Y	N	Off	Off	Off
Cursor enabled for oscilloscope display	7.4	A8 or 7.4SP	N	Y	N	On	On	On
Cursor disabled for oscilloscope display	7.5	A9 or 7.5SP	N	Y	N	Off	Off	Off
Enter Oscilloscope Limits								
Noise Figure Lower Limit	8.1	NL or 8.1SP	N	Y	Y	NC	0	0
Noise Figure Upper Limit	8.2	NU or 8.2SP	N	Y	Y	NC	8	8
Gain Lower Limit	8.3	GL or 8.3SP	N	Y	Y	NC	0	0
Gain Upper Limit	8.4	GU or 8.4SP	N	Y	Y	NC	40	40
Recorder Functions								
Go to Lower Left	20.0	LL or 20.0SP	N	N	N	Off	Off	Off
Go to Upper Right	21.0	UR or 21.0SP	N	N	N	Off	Off	Off
Plot Noise Figure	22.0	A4 or 22.0SP	N	Y	N	Off	Off	Off
Plot Gain	23.0	A5 or 23.0SP	N	Y	N	Off	Off	Off
Strip Chart Mode (X = Noise Figure; Y = Gain)	24.0	A6 or 24.0SP	N	Y	N	Off	Off	Off
¹ Table categories are explained in the Special Function Detailed Operating Instruction.								

Data Output to Oscilloscopes, Recorders and Plotters (cont'd)

(Special Functions 7, 8, 20 through 25, and 47)

Procedure
(cont'd)

Special Function		Program Code HP-IB	Lights Special Function Key	Stored in Continuous Memory	Can be Stored and Recalled	Special Function 0.0 Conditions	Preset (and HP-IB Clear) Conditions	Special Function 0.9 Conditions
Description	Code							
Plotter and HP 8757 Scalar Analyzer Functions								
Plot the grid with units, title and curves.	25.0	PA or 25.0SP	N	N	N	Off	Off	Off
Plot only the grid and annotation.	25.1	PG or 25.1SP	N	N	N	Off	Off	Off
Plot only the data curves.	25.2	PD or 25.2SP	N	N	N	Off	Off	Off
Select the Noise curve pen.	25.3	NP or 25.3SP	N	N	N	Off	1	1
Select the Gain curve pen.	25.4	GP or 25.4SP	N	N	N	Off	2	2
Write the plot title for next plot.	25.5	WT or 25.5SP	N	N	N	Off	HP 8970B Noise Figure Meter	
Enable plotter commands on the System Interface Bus.	47.0	PI or 47.0SP	N	Y	N	NC	NC	On
Enable plot data on the Hewlett-Packard Interface Bus.	47.1	PM or 47.1SP	N	Y	N	NC	NC	Off
Enable plot to HP 8757 Scalar Analyzer.	47.2	ZP or 47.2SP	N	N	N	On	On	On
Disable plot to HP 8757 Scalar Analyzer.	47.3	ZQ or 47.3SP	N	N	N	Off	Off	Off
Number of measurement frequencies per HP 8757 Scalar Analyzer display refresh.	47.5	ZS or 47.5SP	N	N	N	NC	0	0

¹Table categories are explained in the Special Function Detailed Operation Instruction.

Example

The following example shows how to set up the Noise Figure Meter to output a swept CORRECTED NOISE FIGURE AND GAIN measurement result to an oscilloscope and then to plot noise figure and gain results independently. It is assumed that the Noise Figure Meter is already making this type of measurement in one of the Measurement Modes. It is also assumed that the oscilloscope has A vs B (or X/Y) capability.

Data Output to an Oscilloscope

NOTE

The oscilloscope must be an analog oscilloscope. Digital oscilloscopes will not work with the Noise Figure Meter.

The oscilloscope display will flash intermittently if data from a swept measurement is being output to both the oscilloscope and the HP 8757 Scalar Analyzer.

- a. Connect the Y-AXIS, X-AXIS, and Z-AXIS outputs on the rear panel of the Noise Figure Meter to the A, B, and Z (or horizontal, vertical, and Z) inputs of the oscilloscope as appropriate. Select the DC mode for all oscilloscope inputs.

Data Output to Oscilloscopes, Recorders and Plotters (cont'd)

(Special Functions 7, 8, 20 through 25, and 47)

Example (cont'd)

- b. To display the test pattern on the oscilloscope screen press 7 . 1 SPECIAL FUNCTION (or send HP-IB code A1).

NOTE

In the following step, first adjust the position controls on the oscilloscope to place the test pattern on the left side and the bottom. Then, adjust the gain controls to position the right side and top.

- c. Adjust the oscilloscope controls until the test pattern just fills the screen (touching the outer lines on all four sides). See figure below. Verify that the vertical and horizontal lines cross near the center of the screen.

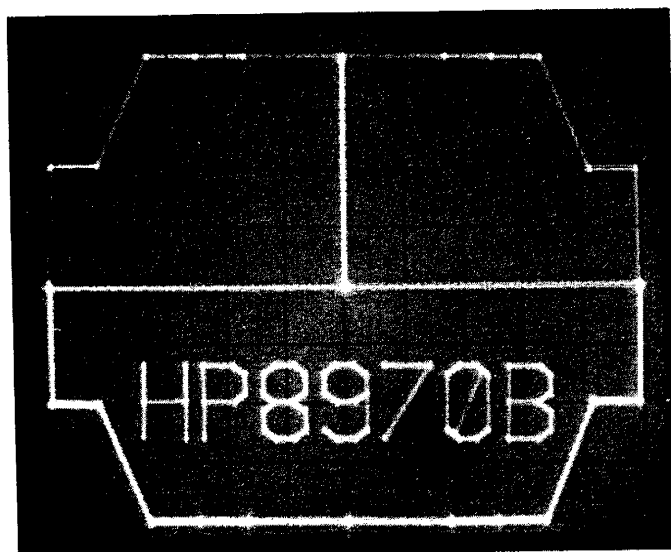

Figure 3-15. Test Pattern on Oscilloscope

NOTE

In the following steps it is assumed that the DUT has a noise figure range of 0.5 to 4 dB and a gain range of 0 to 25 dB over the specified frequency range.

- d. To display the noise figure and gain traces on the oscilloscope screen, press 7 . 0 SPECIAL FUNCTION (or send HP-IB code A0).

e. To display the noise figure lower limit in the left display, press the front panel key GRAPHIC SCALE NOISE MIN or press 8.1 SPECIAL FUNCTION (or send HP-IB code NL). If the left display shows the default value of 0.000 dB, continue with the next step. If the display shows a different value, press 0 and ENTER (or send HP-IB code 0EN).

f. To display the noise figure upper limit in the left display, press the front panel key GRAPHIC SCALE NOISE MAX or press 8.2 SPECIAL FUNCTION (or send HP-IB code NU). The default value is 8.000 dB. To change the upper limit to 4 dB, press 4 and ENTER (or send HP-IB code 4EN).

Data Output to Oscilloscopes, Recorders and Plotters (cont'd)

(Special Functions 7, 8, 20 through 25, and 47)

Example (cont'd)

g. In a similar manner, use front panel key GRAPHIC SCALE GAIN MIN (8.3 SPECIAL FUNCTION or HP-IB code GL) and front panel key GRAPHIC SCALE GAIN MAX (8.4 SPECIAL FUNCTION or HP-IB code GU) to display and change the lower and upper limits of the gain trace. The default values of 0.000 and 40.00 are satisfactory for this example.

h. To display the corrected swept measurement, press CORRECTED NOISE FIGURE AND GAIN (or send HP-IB code M2).

i. For a repetitive swept measurement beginning at the start frequency, press START FREQ and then AUTO (or send HP-IB codes FAW1). Verify the display is similar to that shown below. There should be a noise figure trace and a gain trace.

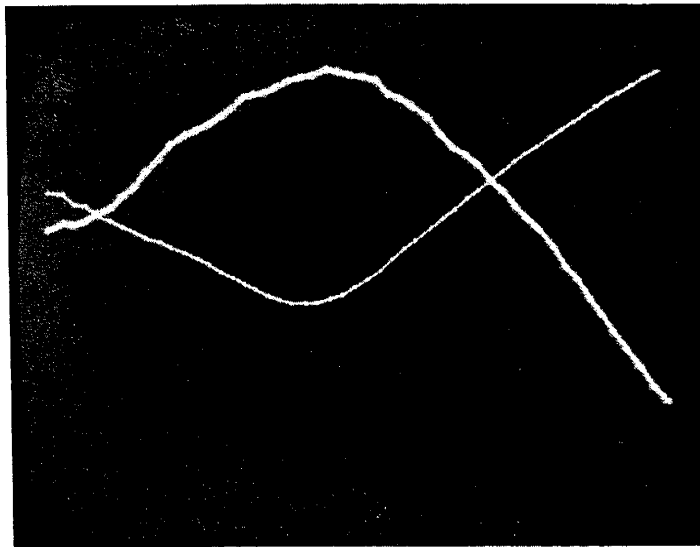

Figure 3-16. Swept Measurement on Oscilloscope

NOTE

If desired, the intensity of the gain trace can be adjusted relative to the noise figure trace. This can be done by turning the GAIN TRACE adjustment on the rear panel of the Noise Figure Meter (see Figure 3-8).

j. To stop the sweep press AUTO again (or send HP-IB code W0). Note that a different HP-IB code is required to turn off the sweep since this function cannot be toggled over the HP-IB.

NOTE

Step j completes the procedure for setting up the Noise Figure Meter for an oscilloscope display. If a permanent record of the measurement results is required, use an oscilloscope camera or perform the sections following the procedure for "Outputting Data to the HP 8757 Scalar Analyzer on the System Interface Bus." Procedures are given for outputting data to a plotter on the System Interface Bus or the Hewlett-Packard Interface Bus and for plotting data on an X-Y recorder.

Data Output to Oscilloscopes, Recorders and Plotters (cont'd)

(Special Functions 7, 8, 20 through 25, and 47)

Example (cont'd)

Outputting Data to the HP 8757 Scalar Analyzer on the System Interface Bus

NOTE

If an analog oscilloscope is not available, the HP 8757 Scalar Analyzer can be used to display the noise figure and/or gain curves from a swept measurement.

The curves are drawn on a calibrated display. The oscilloscope display is not calibrated until Special Function 7.1 and the oscilloscope gain controls have been used. The Scalar Analyzer provides a means of seeing what a plotter output will look like before a plot is done.

k. Connect the HP-IB connector of the HP 8757 Scalar Analyzer to the SYSTEM INTERFACE BUS connector of the Noise Figure Meter.

NOTE

In this configuration the HP-IB connector of the Scalar Analyzer is unavailable for other purposes.

l. Verify that the address set by Special Function 47.4 is the same as the address of the Scalar Analyzer. The default address for Special Function 47.4 and the Scalar Analyzer is 16.

m. Enable a plot to the Scalar Analyzer using Special Function 47.2.

n. The Noise Figure Meter can be set to allow a specific number of measurement frequencies between each refresh of the Scalar Analyzer display. Special Function 47.5 is used to enter the number of measurement frequencies between each display refresh, and the number of measurement frequencies between each refresh can be set from 0 to 255. The default is 0. A default of zero means that the display will be refreshed at the end of each sweep.

NOTE

The time that is required to complete a swept measurement is indirectly proportional to the number of measurement frequencies between each refresh of the display.

To enter the number of measurement frequencies between each display refresh, press 47.5 SPECIAL FUNCTION, key in the number desired and press ENTER.

NOTE

In the following steps it is assumed that the DUT has a noise figure range of 0.5 to 4 dB and a gain range of 0 to 25 dB over the specified frequency range.

The 7.X series of special functions, that apply to an oscilloscope, can still be used with the Scalar Analyzer. There is one exception, Special Function 7.1 is not applicable to the Scalar Analyzer, and if Special Function 7.1 is used, the output to the Scalar Analyzer is suppressed.

Data Output to Oscilloscopes, Recorders and Plotters (cont'd)

(Special Functions 7, 8, 20 through 25, and 47)

Example (cont'd)

o. To display the noise figure and gain traces on the Scalar Analyzer display, press 7.0 SPECIAL FUNCTION (or send HP-IB code A0).

p. To display the noise figure lower limit in the left display, press the front panel key GRAPHIC SCALE NOISE MIN or press 8.1 SPECIAL FUNCTION (or send HP-IB code NL). If the left display shows the default value of 0.000 dB, continue with the next step. If the display shows a different value, press 0 and ENTER (or send HP-IB code 0EN).

q. To display the noise figure upper limit in the left display, press the front panel key GRAPHIC SCALE NOISE MAX or press 8.2 SPECIAL FUNCTION (or send HP-IB code NU). The default value is 8.000 dB. To change the upper limit to 4 dB, press 4 and ENTER (or send HP-IB code 4EN).

r. In a similar manner, use front panel key GRAPHIC SCALE GAIN MIN (8.3 SPECIAL FUNCTION or HP-IB code GL) and front panel key GRAPHIC SCALE GAIN MAX (8.4 SPECIAL FUNCTION or HP-IB code GU) to display and change the lower and upper limits of the gain trace. The default values of 0.000 and 40.00 are satisfactory for this example.

s. To display the corrected swept measurement, press CORRECTED NOISE FIGURE AND GAIN (or send HP-IB code M2).

t. For a repetitive swept measurement beginning at the start frequency, press START FREQ and then AUTO (or send HP-IB codes FAW1). Verify the display is similar to that shown below. There should be a noise figure trace and a gain trace.

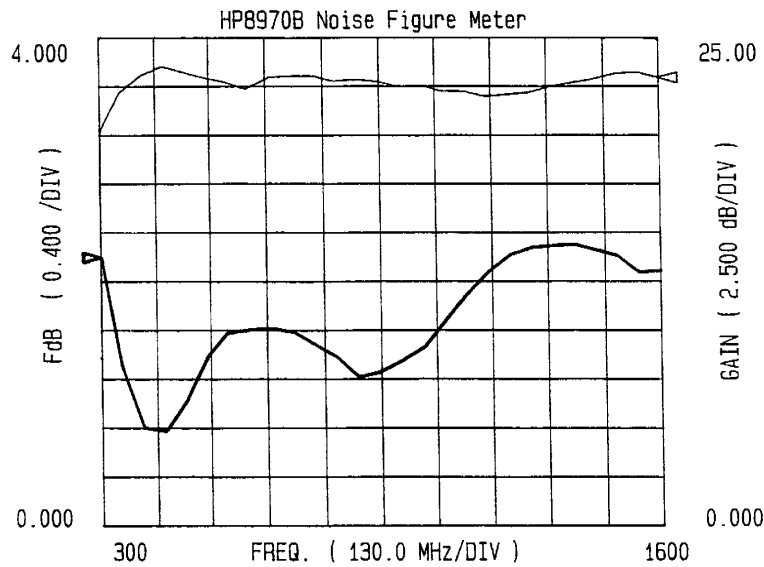

Figure 3-17. Swept Measurement on the Scalar Analyzer

Data Output to Oscilloscopes, Recorders and Plotters (cont'd)

(Special Functions 7, 8, 20 through 25, and 47)

Example (cont'd)

u. To stop the sweep press AUTO again (or send HP-IB code W0). Note that a different HP-IB code is required to turn off the sweep since this function cannot be toggled over the HP-IB. Disable commands to the Scalar Analyzer using 47.3 SPECIAL FUNCTION.

Outputting Data to a Plotter on the System Interface Bus

NOTE

The following Hewlett-Packard plotters can be used with the Noise Figure Meter: HP 9872B, 7440A, 7470A, 7475A, 7550A. In general, most Hewlett-Packard plotters that use HP-IB and support the common command core of HP-GL will work with the Noise Figure Meter.

The maximum number of points that can be plotted is 251. If an attempt is made to plot more than 251 points, error code E39 will appear when Special Function 25.X is entered to start the plot. The maximum number of points is determined by the sweep START FREQ, STOP FREQ and STEP SIZE. Generally the number of points can be arrived at using the following equation:

$$\text{Number of plot points} = \frac{(\text{STOP FREQ} - \text{START FREQ})}{\text{STEP SIZE}} + 1$$

$$\text{If the fractional part of} = \frac{(\text{STOP FREQ} - \text{START FREQ})}{\text{STEP SIZE}} + 1$$

does not equal 0, then add 1.

v. Connect the plotter to the SYSTEM INTERFACE BUS connector on the Noise Figure Meter.

w. Special Function 47.0 (plotter is on the System Interface Bus) active.

x. The address of the plotter must match the address of the plotter stored in the Noise Figure Meter. Use Special Function 40.3 (plotter system interface bus address) to display and change, if necessary, the address of the plotter stored in the Noise Figure Meter. The default address for the plotter is 5.

NOTE

When the plot starts, Error 45 (E45) will be given if the Noise Figure Meter can not find the plotter at the address set by Special Function 40.3, the plotter is not turned on or the plotter is not connected to the SYSTEM INTERFACE BUS connector with an HP-IB cable.

y. The default title of the plot will be HP 8970B Noise Figure Meter. The user can supply a title using Special Function 25.5. The title is placed at the top of the plot grid and can be sixty-five (65) characters long. The title is entered with ASCII characters (in decimal) using the front panel numeric key pad. When using HP-IB, the title is sent the way it will appear on the plot. For example, a title would be sent over HP-IB using the following format:

OUTPUT 708; "WT This would be a title of up to 65 characters."

Data Output to Oscilloscopes, Recorders and Plotters (cont'd)

(Special Functions 7, 8, 20 through 25, and 47)

Example

z. The pens used to make the plot can be selected using Special Functions 25.3 (noise) and 25.4 (gain curve). The default pens are 1 (noise) and 2 (gain).

aa. Perform a SINGLE or AUTO sweep to gather data for the plot.

NOTE

The plot will be aborted if an HP-IB command is sent to the Noise Figure Meter or a front panel key is pressed during the plot.

ab. Start the plot by using Special Function 25.0, 25.1 or 25.2.

NOTE

If Special Function 7.1 (test pattern) was selected earlier and Special Function 25.0, 25.1 or 25.2 has been selected, the plotter will not produce a plot.

If the Noise Figure Meter measurement is UNCORRECTED, the gain curve will not be plotted.

ac. The plotted traces will be the same as the traces that were displayed on the oscilloscope.

Outputting Data to a Plotter on the Hewlett-Packard Interface Bus

NOTE

The controller should be able to accept a very large string on the order of 1000 to 6000 bytes or more depending on the number of points that are to be plotted.

In general, the controller should be able to accept the number of points as described in the following equation:

$$P = 1000 + [12 (N)]$$

P = Number of Points

N = Total Number of Noise Figure and Gain Points

ad. Connect the controller and the plotter to the HP-IB connector on the Noise Figure Meter.

ae. Special Function 47.1 (plot data is on HP-IB) must be active.

af. The address of the plotter must match the address that the controller will use later to send data to the plotter.

NOTE

If the controller sends a command to the Noise Figure Meter when it is expecting to have a plot read, the plot is aborted. Hitting a front panel key also aborts the plot.

When Special Function 47.1 is selected and a plot is started, the Noise Figure Meter's front panel will display "Plot." If data is not read from the Noise Figure Meter, the front panel will continue to display "Plot" until data is read, the Noise Figure Meter receives an HP-IB command or a front panel key is pressed.

Data Output to Oscilloscopes, Recorders and Plotters (cont'd)

(Special Functions 7, 8, 20 through 25, and 47)

Example (cont'd)

ag. The following program example shows how to get data from the Noise Figure Meter to the controller and from the controller to the plotter:

NOTE

The program assumes that the address of the Noise Figure Meter is set to eight and the plotter address is set to five. Also, it is assumed that a measurement has been made and now it is desired to plot the data.

This program was written in BASIC language 3.0 using the HP 9000 Series 200 Model 236 computer.

10 DIM A\$(30000)	!Setup a large string for the plot data.
20 OUTPUT 708;"PM"	!Read plot data on HP-IB.
30 OUTPUT 708;"PA"	!Start the plot.
40 ENTER 708;A\$!Get the plot data.
50 OUTPUT 705;A\$!Send data to plotter at address 5.
60 END	

ah. The plotted traces should be the same as the traces that were displayed on the oscilloscope.

Plotting Data on an X-Y Recorder

ai. Connect the X-AXIS, Y-AXIS, and Z-AXIS outputs from the Noise Figure Meter to the X, Y, and pen lifts inputs of the X-Y recorder. Select DC mode on all recorder inputs.

aj. To adjust the lower left point on the recorder, press 20.0 SPECIAL FUNCTION (or send HP-IB code LL) and adjust the X and Y zero-set controls on the recorder.

ak. To adjust the upper right point on the recorder, press 21.0 SPECIAL FUNCTION (or send HP-IB code UR) and adjust the X and Y vernier controls on the recorder.

NOTE

The X-AXIS and Y-AXIS output voltages from the Noise Figure Meter vary from 0 to 6V. Therefore, it may be necessary to adjust the recorder to accommodate this range of voltages.

al. Check both the upper and lower limits on the recorder and readjust as required.

am. To plot a single sweep of the noise figure results, press 22.0 SPECIAL FUNCTION and then SINGLE (or send HP-IB codes A4W2). When the single sweep is complete, the Noise Figure Meter remains tuned to the stop frequency.

an. To plot a single sweep of the gain results, press 23.0 SPECIAL FUNCTION and then SINGLE (or send HP-IB codes A5W2). When the single sweep is complete, the Noise Figure Meter remains tuned to the stop frequency.

ao. The plotted traces should be similar to the traces that were displayed on the oscilloscope.

Data Output to Oscilloscopes, Recorders and Plotters (cont'd)

(Special Functions 7, 8, 20 through 25, and 47)

Program Codes

For HP-IB codes, refer to Procedure.

HP-IB

Comments

For the oscilloscope, recorder and plotter modes, whatever is displayed in the NOISE FIGURE display is treated as a noise figure trace. For example, if Special Function 9 is active, the power measurement information displayed is output to the oscilloscope, recorder or plotter as if it were noise figure information. Noise figure is displayed in the units selected by Special Function 10 and gain is displayed in dB.

Special Function 8 or the front panel Graphic Scale Keys are used to set both noise figure and gain limits.

Special Function 24 selects the strip chart mode. This mode is useful in plotting noise figure and gain versus time. For example, it can be used to plot noise figure versus emitter current on an X-Y recorder or to drive an external meter. The X-AXIS output is the noise figure information and the Y-AXIS output is the gain information.

Related Sections

Display Units Selection
Measurement Modes 1.0 through 1.9
Special Functions

Display Control (Special Function 16)

Description

Special Function 16 allows the user to select the kind of information that will be shown by the left front panel display or to disable the front panel displays.

Special Function 16.0 enables the left display to display the measurement frequency. In this mode the front panel displays function normally.

Special Function 16.1 enables the left display to display the IF into the Noise Figure Meter (Measurement Modes 1.1 through 1.4) or the IF into the Noise Figure Test Set (Measurement Modes 1.5 through 1.9). Special Function 16.1 is particularly useful in Measurement Modes 1.2 and 1.7. In these modes the left display normally displays the measurement frequency before it has been down converted. With Special Function 16.1 the IF into the Noise Figure Meter or Noise Figure Test Set is displayed.

Special Function 16.2 blanks the left (frequency) display. In this mode, parameters being displayed or changed are shown in the left display until the ENTER or FREQUENCY key is pressed. When the START FREQ or STOP FREQ key is pressed, the start and stop frequencies are displayed. Once the start and stop frequencies have been entered, press the FREQUENCY key to blank the left display again. The left display is blank during a SINGLE or AUTO sweep.

Special Function 16.3 blanks all the front panel displays. The displays are not updated. The message DISP Off is displayed in the right displays. The Noise Figure Meter runs slightly faster in this mode.

Procedure

To select one of the Display Control special functions, key in the special function desired and then press the SPECIAL FUNCTION key.

Special Function		Program Code HP-IB	Lights Special ¹ Function Key	Stored in Con- tinuous Memory	Can be Stored and Recalled	Special Function 0.0 Conditions	Preset (and HP-IB Clear) Conditions	Special Function 0.9 Conditions
Description	Code							
Measurement frequency is displayed	16.0	DF or 16.0SP	N	Y	Y	On	On	On
Input IF is displayed	16.1	DI or 16.1SP	N	Y	Y	Off	Off	Off
Measurement frequency is not displayed	16.2	BF or 16.2SP	N	Y	Y	Off	Off	Off
Front panel displays are disabled	16.3	BA or 16.3SP	N	Y	Y	Off	Off	Off

¹Table categories are explained in the Special Function Detailed Operating Instruction.

Display Control (cont'd)

(Special Function 16)

Example To blank the left (frequency) display:

LOCAL (keystrokes)	<div style="display: flex; justify-content: space-around; align-items: center;"> <div style="text-align: center;"> <p>Code</p> <div style="display: flex; justify-content: center; gap: 5px;"> <div style="border: 1px solid black; padding: 2px 5px;">1</div> <div style="border: 1px solid black; padding: 2px 5px;">6</div> <div style="border: 1px solid black; padding: 2px 5px;">.</div> <div style="border: 1px solid black; padding: 2px 5px;">2</div> </div> </div> <div style="text-align: center;"> <p>Function</p> <div style="border: 1px solid black; padding: 2px 5px; display: flex; align-items: center; justify-content: center;"> • <p style="margin: 0;">SPECIAL FUNCTION</p> </div> </div> </div>
<div style="text-align: center; margin-bottom: 5px;"> HP-IB </div> (program codes)	BF

Program Codes

For HP-IB codes, refer to the Procedure above.



Related Sections

Measurement Modes 1.1 through 1.9

Display Resolution (Includes Special Function 12)

Description

The Noise Figure Meter can vary the resolution of the INSERTION GAIN and NOISE FIGURE displays.

The table below shows the maximum resolution (to the right of the decimal point) allowed by Special Function 12.

Display	12.0SP Maximum Resolution	12.1SP Less Resolution on NOISE FIGURE	12.2SP Less Resolution on GAIN
NOISE FIGURE			
F dB	dd.dd	dd.d	
F	d.ddd	d.dd	
Y dB	dd.dd	dd.d	
Y	d.ddd	d.dd	
Te K	ddd.d	ddd	
INSERTION GAIN			
dB	dd.dd		dd.d

Procedure

To select the desired display resolution, key in the corresponding Special Function code and then press the SPECIAL FUNCTION key.

Special Function		Program Code HP-IB	Lights Special ¹ Function Key	Stored in Continuous Memory	Can be Stored and Recalled	Special Function 0.0 Conditions	Preset (and HP-IB Clear) Conditions	Special Function 0.9 Conditions
Description	Code							
Maximum resolution for both INSERTION GAIN and NOISE FIGURE displays	12.0	X0 or 12.0SP	N	Y	N	On	On	On
Less resolution on NOISE FIGURE display	12.1	X1 or 12.1 SP	N	Y	N	Off	Off	Off
Less resolution on INSERTION GAIN display	12.2	X2 or 12.2SP	N	Y	N	Off	Off	Off

¹Table categories are explained in the Special Function Detailed Operation Instruction.

Display Resolution (cont'd)

(Includes Special Function 12)

Example

To have less resolution in the NOISE FIGURE display:

LOCAL (keystrokes)	<div style="display: flex; justify-content: space-around; align-items: center;"> <div style="text-align: center;"> Code 1 2 . 1 </div> <div style="text-align: center;"> Function ● SPECIAL FUNCTION </div> </div>
<div style="text-align: center; margin-bottom: 5px;"> HP-IB </div> (program codes)	X1

Program Codes

For HP-IB program codes, refer to Procedure above.



Indications

The NOISE FIGURE and INSERTION GAIN displays reflect the resolution corresponding to the selected Special Function.

Comments

Special Function 12 also affects the resolution of the HP-IB output. The HP-IB output always has one digit more of resolution than the front panel displays.

Related Sections

Display Units Selection
Special Functions

Display Units Selection (Special Function 10)

Description

Noise measurements can be output in the following display units:

- a. noise figure in dB (F dB)
- b. noise figure as a ratio (F)
- c. Y factor in dB (Y dB)
- d. Y factor as a ratio (Y)
- e. equivalent input noise temperature in kelvins (Te K)

Procedure

To select a NOISE FIGURE display unit, key in the corresponding Special Function code and then press the SPECIAL FUNCTION key.

Special Function		Program Code HP-IB	Lights Special Function Key	Stored in Continuous Memory	Can be Stored and Recalled	Special Function 0.0 Conditions	Preset (and HP-IB Clear) Conditions	Special Function 0.9 Conditions
Description	Code							
F dB	10.0	N0 or 10.0SP	N	Y	Y	On	On	On
F	10.1	N1 or 10.1SP	N	Y	Y	Off	Off	Off
Y dB	10.2	N2 or 10.2SP	N	Y	Y	Off	Off	Off
Y	10.3	N3 or 10.3SP	N	Y	Y	Off	Off	Off
Te K	10.4	N4 or 10.4SP	N	Y	Y	Off	Off	Off

Table categories are explained in the Special Function Detailed Operation Instruction.

Example

To have measured noise displayed as Y factor in dB:

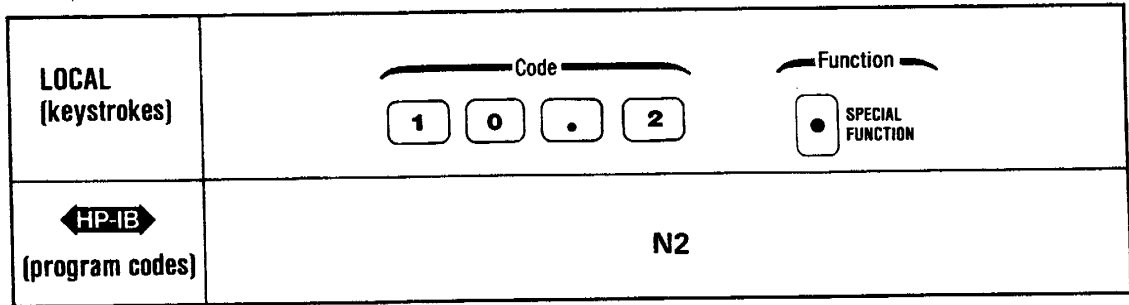

Program Codes



For HP-IB program codes, refer to Procedure above.

Indications

The selected display unit appears on the right side of the NOISE FIGURE display. Special Function 10 has no effect on the INSERTION GAIN display.

Comments

32 dB is the maximum value that can be displayed in units of F dB. Readings above this value cause the NOISE FIGURE display to show two dashes “ — — ”. The smoothed number is the value that is checked against 32 dB. Therefore, if the display is flashing between approximately 30 dB and “ — — ”, increasing the smoothing may provide a stable display if the noise figure is less than 32 dB.

The maximum value allowable for Te K is 9999K (noise figure of 15.5 dB).

Display Units Selection (cont'd)

(Special Function 10)

Comments (cont'd)

The maximum value allowable for F is 9999 (noise figure of approximately 40 dB).

Equations for the display units are as follows:

$$F = \frac{\text{noise power added by DUT} + \text{noise power out due to source}}{\text{noise power out due to source}}$$

(when the source is a 290K)

$$F(\text{dB}) = 10 \log F$$

$$Y = \frac{\text{power measured with noise source On}}{\text{power measured with noise source Off}}$$

$$Y(\text{dB}) = 10 \log Y$$

$$T_e = \frac{T_{\text{hot}} - Y \times T_{\text{cold}}}{Y - 1}$$

where: T_{hot} is the equivalent temperature of the noise source when it is On
and

T_{cold} is the equivalent temperature of the noise source when it is Off.

Related Sections

Display Resolution
Noise Figure (Uncorrected) and Noise Figure and Gain (Corrected)
Smoothing
Special Functions

ENR Table Entry

Description

The ENR key is used to store, recall or display an ENR (Excess Noise Ratio) table. The Noise Figure Meter can store the ENR tables for five noise sources. Each table can have up to thirty-five frequency/ENR pairs. This information is used to improve the accuracy of the noise figure and gain calculations made by the Noise Figure Meter. The information entered is the actual Excess Noise Ratio (ENR) value at the specified frequency. All noise sources have this calibration information available. In the case of the HP 346A, B and C Noise Sources, a separate printout is supplied, and a graph or table is printed on the side of the Noise Source showing the ENR versus Frequency data. The frequency/ENR pairs shown on the printout or graph are the values that are entered into one of the ENR tables. The valid frequency range for entries is from 10 MHz to 99999 MHz. The valid power range for the ENR entries is from -6 to +50 dB.

During a measurement the Noise Figure Meter searches the ENR table until the measurement frequency is found. If the measurement frequency is between ENR table entries, the Noise Figure Meter will interpolate the ENR data. If the measurement frequency is higher than the highest table entry, the Noise Figure Meter will use the ENR value of the highest table entry. If the measurement frequency is lower than the lowest table entry, the Noise Figure Meter will use the ENR value of the lowest table entry. When power is initially applied to the Noise Figure Meter, the ENR table contains the default value of 15.20 dB at all frequency points. After an ENR table is entered for a specific noise source, this information is retained in the continuous memory and need not be re-entered each time power is turned off and on.

Procedure

This discussion will cover the following areas:

- Entering a new ENR (Excess Noise Ratio) table
- Editing an ENR table
- Viewing information on stored ENR tables

NOTE

The Noise Figure Meter has five tables (Tables 0-4) that are used for ENR data. Tables 1-4 are used to store ENR data. Table 0 contains the ENR data that is currently being used. Information in Table 0 can be stored to Tables 1-4. Information in Tables 1-4 can be recalled to Table 0.

If ENR data has not been previously entered into any of the tables (as with a new Noise Figure Meter), the tables will contain the following default information: The frequency points will be 10, 100, 1000 through 26000 (every 1000 MHz) and 26500 MHz. There won't be any default frequencies after the thirty-first (31) table entry. The ENR value will be 15.20 dB for each frequency point.

Setting the ENR Source Identifier.

NOTE

The ENR source identifier is a unique number used to identify the Noise Source associated with one of the stored ENR tables. The ENR source identifier should be set before the ENR data is entered into the table. If a

ENR Table Entry (cont'd)

Procedure (cont'd)

table other than Table 0 is to be edited, that table will have to be recalled into Table 0, before the table can be edited. ENR editing is always done to Table 0. To recall a table, key in the following sequence:

RECALL ENR X

X is the number of the table (1—4) to be recalled. Rcl will appear in the INSERTION GAIN display and Enr will appear in the NOISE FIGURE display. After the table number is keyed in, the displays return to what they were displaying before the recall.

1. Press 5.5 SPECIAL FUNCTION. A five digit number will appear in the left display; if the number is less than five digits, leading zeros will be added to the number. In either case, five digits will be displayed. This number is used to identify the Noise Source associated with the ENR table currently in Table 0. The last five digits of the Noise Source serial number are suggested as the number to use as the identifier.

With Special Function 5.5 activated, key in the new identifier. The number will begin to appear in the left display; press ENTER. The values in the other two displays are dependent on what action the Noise Figure Meter is performing and are not affected by the entering of the Noise Source identifier.

Entering or Editing an ENR table

NOTES

The following procedure describes how to enter a new ENR table. The same procedure is used if an existing ENR table is being edited.

The following discussion describes four keys used to look at data, enter data or edit data in an ENR table after the ENR key has been pressed.

- *The UP ARROW and DOWN ARROW allow the user to scroll between ENR tables (Special Function 5.6) or to scroll through information within a table (ENR Editing).*
- *The DECREASE key is used to delete an ENR entry. Press the DECREASE key and the frequency currently being displayed is deleted. This key is very helpful in deleting unwanted default frequencies.*
- *The INCREASE key is used to insert a new ENR entry before the ENR data currently being displayed. After pressing INCREASE the ENR table entry number, in the NOISE FIGURE display, will be the same number that was displayed before the INCREASE key was pressed. The INSERTION GAIN display will show an ENR of 15.2 dB. The left display will show a frequency that is the average of the old frequencies that surround the new entry. The new frequency and ENR value can be entered using the procedure in steps 2 through 4.*

If data is read, over the Hewlett-Packard Interface Bus, from the Noise Figure Meter during ENR Table Entry, the Noise Figure Meter will output a special HP-IB code for the NOISE FIGURE window. For more information about this special HP-IB code, refer to the Error Messages and Recovery Detailed Operating Instruction.

ENR Table Entry (cont'd)

Procedure (cont'd)

1. If a new ENR table is being entered, go to step 2. If an existing ENR table is to be edited, continue with this step.

If the table to be edited is not in Table 0, the table will have to be recalled. Use the following key sequence to recall an existing ENR table:

RECALL ENR X

X is the number of the table (1—4) to be recalled.

When doing a recall, rcl appears in the INSERTION GAIN display and Enr appears in the NOISE FIGURE display. When the table number is keyed in, the displays return to what they were displaying before the recall was done.

2. Press the ENR key. The displays will be as shown below:

FFFF	EEEE	T-NN
------	------	------

FFFF is the first frequency in Table 0. EEEE is the ENR for the first frequency in Table 0. T is the ENR table number (in this case 0). NN is the ENR table entry number (1 through 35).

NOTE

When editing, T is the number of the most recently recalled table. T will be zero if a change has been made to the table after it was recalled.

3. The MHz annunciator in the left display will be blinking. This indicates that the frequency can be changed, if desired. To change the frequency, key in the new frequency and press ENTER. The new frequency will appear as it is typed. If an error is made before ENTER is pressed, press NOISE FIGURE. This will return the original frequency to the display. The new frequency can then be re-entered. If an error was made after ENTER was pressed, press DOWN ARROW and then UP ARROW. The MHz annunciator in the left display will begin blinking indicating that the frequency can be changed. If the default frequency is being used, press ENTER. In either case, pressing ENTER will cause the dB annunciator in the INSERTION GAIN display to begin blinking.
4. The blinking dB annunciator indicates that the ENR value can be changed, if desired. To change the ENR value, key in the new value and press ENTER. The new ENR value will appear as it is typed. With one exception, the error recovery procedure is the same as that described for frequency in step 3. If the error is made after ENTER is pressed, press DOWN ARROW and ENTER. Then re-enter the ENR value. If the default ENR value is being used, press ENTER. In either case, pressing ENTER will cause the MHz annunciator in the left display to begin blinking and the next entry in the table will be displayed.

Once the frequency and the ENR value have been entered, the ENR table entry number, in the NOISE FIGURE display, will increase by one. If any values have been entered, the ENR table number will be set to zero.

ENR Table Entry (cont'd)

Procedure (cont'd)

5. Repeat steps 3 and 4 as needed to make all ENR table entries.
6. After all frequencies and ENR values have been entered, the information must be stored to Table 1, 2, 3 or 4. If the information is not stored, it will be lost the next time one of the tables (Tables 1-4) is recalled to Table 0. The store procedure will save the Noise Source identifier and the ENR data.
7. To store the information, key in the following sequence:

STORE ENR X

X is the number of the table (1—4) where the information is stored.

When a store is keyed in, the INSERTION GAIN display shows Sto and the NOISE FIGURE display shows Enr. After the table number is entered, the displays return to what they were previously displaying.

8. To terminate ENR table entry mode, press FREQUENCY or send HP-IB code FR.

Viewing Information on Stored ENR Tables

Press 5.6 Special Function. This special function will cause the following information to be displayed:

IIII		T-NN
------	--	------

IIII is the ENR source identifier. T is the ENR table number. NN is the number of entries in the table. The INSERTION GAIN display does not have any information displayed in this mode.

Information on other tables can be viewed by using the UP ARROW and DOWN ARROW keys.

NOTE

If data is read, over the Hewlett-Packard Interface Bus, from the Noise Figure Meter when Special Function 5.6 (HP-IB code NS) is active, the Noise Figure Meter will output a special HP-IB code for the NOISE FIGURE window. For more information about this special HP-IB code, refer to the Error Messages and Recovery Detailed Operation Instruction.

Pressing ENTER causes the Noise Figure Meter to resume normal measurement mode.

Program Codes

HP-IB

The HP-IB code to enable ENR table entry is NR. The HP-IB code for Special Function 5.5 (Noise Source identifier) is SN. The HP-IB code for Special Function 5.6 (Noise Source catalog) is NS.

Comments

The following program is an example of how to download an ENR table into the Noise Figure Meter:

ENR Table Entry (cont'd)

Comments (cont'd)

NOTE

This program example was written in BASIC language 3.0 using the HP 9000 Series 200 Model 236 computer.

```

10 DIM Freq(5,40),Enr(5,40)
20 Nfm=708                                !Address of the Noise Figure Meter
30 N=20                                    !Number for frequency/ENR pairs.
40 DATA 10,15.20,100,15.40,1000,15.20,2000,15.2,3000,15.00
50 DATA 4000,15.00,5000,15.10,6000,15.20,7000,15.20,8000,15.30
60 DATA 9000,15.40,10000,15.50,11000,15.60,12000,15.60,
70 DATA 13000,15.45,14000,15.50,15000,15.35,16000,15.30,
80 DATA 17000,15.30,18000,15.30
90 T=1
100 FOR I=1 TO N                            !FILL UP A TABLE
110   READ Freq(T,I)                        !READ FREQUENCY VALUE
120   READ Enr(T,I)                         !READ ENR VALUE
130 NEXT I
140 OUTPUT Nfm;"NR"                          !GO INTO ENR EDIT MODE
150 FOR I=1 TO N                            !SEND THE ENR TABLE
160   OUTPUT Nfm;Freq(T,I);"EN";Enr(T,I);"EN"
170   PRINT "SENDING FREQ/ENR VALUES OF: ";Freq(T,I),Enr(T,I)
180 NEXT I
190 OUTPUT Nfm;"FR"                          !END ENR ENTRY
200 PRINT
210 PRINT "DONE DOWNLOADING THE ENR TABLE."
220 END

```

The ENR table is used during both **UNCORRECTED NOISE FIGURE** measurements and **CORRECTED NOISE FIGURE AND GAIN** measurements.

The specific ENR vs. frequency data that is used is determined by the stimulus frequency and the measurement mode that has been selected. Refer to Measurement Modes 1.0 through 1.9 Detailed Operating Instructions for additional information.

Special Function 0.9 or PRESET has no effect on data stored in the ENR tables.

Special Function 0.9 or PRESET sets Table 0 as the table that is used for calibration and the measurement.

Related Sections

Measurement Modes 1.0 through 1.9
Spot ENR, T_{hot} , T_{cold} and ENR Table Selection.

3-92 This Page Intentionally Left Blank

Error Messages and Recovery

Description

The instrument generates error messages to indicate operating problems, incorrect keyboard entries, or service-related problems. The error message is cleared when the error condition is removed. The error messages are grouped by error code as follows:

Error 10 through Error 49 and Error 106. These are operating and entry errors which indicate that not all conditions have been met to assure a calibrated measurement, or that an invalid keyboard or HP-IB entry has been made. Operating errors can usually be cleared by using the front panel controls, changing the equipment setup, or correcting the HP-IB code. Entry errors require that a new keyboard entry or function selection be made. A number of errors in this group may represent instrument malfunctions. The operator should try to clear the error condition using the corrective actions shown in the table below before referring the unit for service.

Error 60 through Error 80. These are service errors which provide service-related information. Service errors are discussed in Section VIII of the Service Manual.

Error 100 through Error 105. These are Noise Figure Test Set operational and service errors.

Errors may also be classified as volatile or nonvolatile.

Nonvolatile errors typically occur when the instrument has received conflicting commands from the operator. The instrument stops making measurements and waits for the conflict to be resolved by the operator. An example of this type of conflict is selecting a corrected measurement when a calibration has not been performed. All hardware errors are also nonvolatile.

Volatile errors typically represent invalid entries of either frequency, special function codes, numerical data, or HP-IB characters. Volatile errors are cleared when a front panel key is pressed or when a serial poll is performed over the HP-IB. Upon clearing a volatile error, the invalid entry is ignored by the instrument and measurements resume as if the entry was never received.

The last volatile or nonvolatile error generated can be displayed using Special Function 99.1 (HP-IB code ER). The error may already be resolved or can be active. When the error is requested over HP-IB, the error will be displayed using the error code or can be displayed in English. Using the English display, an error code does not have to be interpreted. The Comments section, at the end of this instruction, contains a program for displaying the error in English.

HP-IB Output Format

HP-IB

The HP-IB output format for errors is:



For example, Error 10 is output to the HP-IB as +90010E+06CRLF. This format differs from normal data outputs since normal data outputs will never exceed 1×10^5 . Once an error has been input to the computing controller, the error code is simply derived by subtracting 9×10^{10} from the input number, and then dividing the result by 1 000 000.

Error Messages and Recovery (cont'd)

HP-IB Output Format
HP-IB
 (cont'd)

Special Codes Over HP-IB. When a read of the Noise Figure Meter is attempted during the following operations: ENR editing, ENR catalog, Noise Figure Test Set Coarse or Fine Tuning Calibration, the Noise Figure Meter will output special HP-IB codes for the NOISE FIGURE window. The special HP-IB codes are given below:

ENR Editing



ENR Catalog

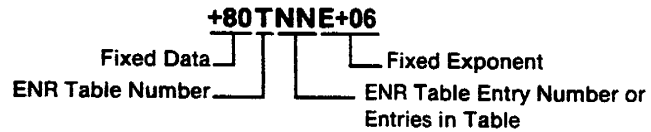

**Noise Figure Test Set
 Fine Tuning Calibration:**

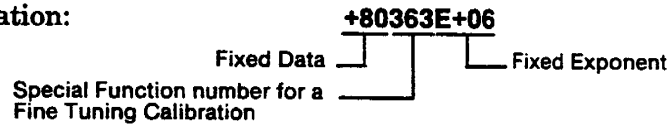

**Noise Figure Test Set
 Coarse Tuning Calibration:**

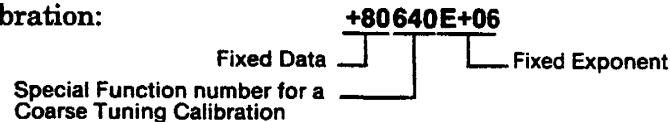

One purpose for these special codes would be to read back from the Noise Figure Meter until the codes stop being sent, which would mean the task is complete. This would be useful when doing a coarse or fine tune calibration.

Timeouts should not be used with these special codes. If a timeout is used, it should be at least sixty seconds. This is necessary because it may take the Noise Figure Meter many seconds to set up the special code for output. This is the case for coarse and fine tune calibration.

Error Displays

There are three types of error displays. All three use the format shown above to output the error message to the HP-IB. The following examples illustrate each type:



The display above shows the general error display format. E means error while the number is the error code.

Error Messages and Recovery (cont'd)

Error Displays (cont'd)

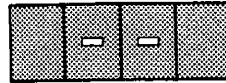

This display indicates that a measurement overflow has occurred or that the measured noise figure exceeds 32 dB. This display is output to the HP-IB as E99 using the HP-IB output format 90099E+06CRLF.

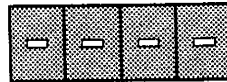

The display above indicates that the data is not ready. This display is output to the HP-IB as a special reserved number (90000E+06CRLF).

Error Messages

The table below describes all operating and entry errors. The error code, message, and the action typically required to remove the error-causing condition are given. Additional information pertaining to particular errors is also given.

Error Code	Volatile (V) or Nonvolatile (NV)	Message	Recommended Action/Comments
Hardware Error			
General Remedy: Press PRESET and check that input signal is within the specified amplitude and frequency range.			
10	NV	A/D conversion failed.	Refer to Service-Related Errors in Section VIII, Service. ¹
11	NV	A/D converter overflow.	Set IF and RF attenuators to autorange (Special Functions 70.0 and 60.0). If error persists, refer to Service-Related Errors in Section VIII, Service. ¹ Also check for proper operation of the Noise Source.
12	NV	Input overflow.	Set RF attenuators to autorange (Special Function 60.0). If error persists, refer to Service-Related Errors in Section VIII, Service. ¹
13	NV	IF attenuator calibration failed.	Refer to the Calibration, IF Attenuators Detailed Operating Instruction. If error persists, refer to Service-Related Errors in Section VIII, Service. ¹
14	NV	Proper IF or RF attenuators cannot be selected.	Refer to Service-Related Errors in Section VIII, Service. ¹

¹ Section VIII, Service, is in the Service Manual. The part number of the Service Manual is on the title page of this manual.

Error Messages and Recovery (cont'd)

Error Messages (cont'd)

Error Code	Volatile (V) or Nonvolatile (NV)	Message	Recommended Action/Comments
Hardware Error (cont'd)			
18	NV	Frequency calibration failed.	Refer to Service-Related Errors in Section VIII, Service. ¹
19	NV	Noise Figure Test Set YIG Filter calibration (coarse or fine) failed.	Refer to the Comments section at the end of this instruction.
Not Properly Calibrated For Corrected Measurement			
General Remedy: Repeat calibration.			
20	NV	Not calibrated.	Perform calibration prior to selecting CORRECTED NOISE FIGURE AND GAIN measurement.
21	NV	Current frequency is out of calibrated range or not a calibrated point in Modes 1.5–1.9	Select frequency within calibrated range, calibrate over a new frequency range, or refer to Special Function 39, in Modes 1.5–1.9.
22	NV	Current RF attenuation not calibrated	Select appropriate input gain calibration range (Special Function 32).
23	NV	Not calibrated in the current measurement and sideband modes.	Perform calibration in current measurement and sideband modes.
24	NV	Not calibrated for the current IF (Measurement Modes 1.1, 1.3, 1.6 and 1.8).	Perform calibration. (Changing any IF requires recalibration; refer to Special Functions 3 and 19.)
25	NV	Not calibrated for the current LO frequency (Measurement Mode 1.2 and 1.7).	Perform calibration. (Changing the LO frequency requires recalibration; refer to Special Function 3.)
26	NV	Internal IF attenuators not calibrated.	Refer to the Calibration, IF Attenuators Detailed Operating Instruction.
27	NV	Overflow while calibrating.	Too much loss in calibration system. Check input gain calibration setting (Special Function 32). Check for proper Noise Source

¹ Section VIII, Service, is in the Service Manual. The part number of the Service Manual is on the title page of this manual.

Error Messages and Recovery (cont'd)

Error Messages (cont'd)

Error Code	Volatile (V) or Nonvolatile (NV)	Message	Recommended Action/Comments
Not Properly Calibrated For Corrected Measurement (cont'd)			
28	NV	Noise Figure Test Set fine tuning calibration is needed.	operation. Verify that the Noise Source can supply enough ENR (Excess Noise Ratio). Refer to comments. Refer to the Comments section at the end of this instruction and the Noise Figure Test Set YIG Filter Calibration Detailed Operating Instruction.
29	NV	Noise Figure Test Set coarse tuning calibration is needed.	Refer to the Comments section at the end of this instruction and the Noise Figure Test Set YIG Filter Calibration Detailed Operating Instruction.
Invalid Frequency Error			
General Remedy: Change frequency parameter and repeat measurement.			
30	V	Start frequency is greater than stop frequency during calibration or plot. Or, the lower limit is greater than the upper limit (noise or gain) during sweep.	Set start frequency (or lower limit) to a value less than the stop frequency (or upper limit).
31	V	Number of calibration points exceeds 181.	Reduce the number of calibration points. (Reduce calibration range or increase step size.)
32	V	LO (set by Special Function 3.1) frequency will be out of range.	Change IF, START FREQ, STOP FREQ, or sideband selection so that system LO does not tune through 0 MHz.
33	V	IF into Noise Figure Meter will be out of range.	If single sideband has been selected, change START FREQ, STOP FREQ, or LO (set by Special Function 3.1) frequency so that the difference between the LO (set by Special Function 3.1) frequency and the start or stop frequency is greater than 10 MHz and less than 1600 MHz; 2047 MHz, opt 020 (modes 1.1 to 1.4) or

Error Messages and Recovery (cont'd)

Error Messages (cont'd)

Error Code	Volatile (V) or Nonvolatile (NV)	Message	Recommended Action/Comments
Invalid Frequency Error (cont'd)			
34	NV	Double sideband is not allowed in Measurement Modes 1.2 or 1.7.	26500 MHz (1.6 to 1.9). If sum function (Special Function 2.3) is being used, change START FREQ or LO (set by Special Function 3.1) frequency so that LO plus START or STOP FREQ is within 10 - 1600 MHz (2047 MHz, opt 020) range. Use single sideband (Special Function 2.1—2.3) with Measurement Modes 1.2 or 1.7.
Entry Error			
General Remedy: Check and repeat entry.			
35	V	Entered value is out of range.	Re-enter new value.
36	V	Undefined special function.	Check, then re-enter correct special function code.
37	V	Cannot enter specified parameter.	Select proper function that allows entry of this parameter.
38	V	Noise Figure Test Set IF will be out of range.	Refer to the Comments section at the end of this instruction.
39	V	The number of plot points exceeds 251.	Change START FREQ, STOP FREQ or STEP SIZE to reduce the number of plot points below 251. Also, refer to the Data Output to Oscilloscopes, Recorders and Plotters Detailed Operating Instruction.
HP-IB HP-IB Errors			
General Remedy: Check and repeat entry.			
40	V	Undefined HP-IB code.	Check, then re-enter correct HP-IB code.
41	V	Invalid HP-IB characters.	Check, then re-enter valid HP-IB characters.
42	NV	System Local Oscillator not found on System Interface Bus with 46.0 SP active.	Refer to the Comments section at the end of this instruction.

Error Messages and Recovery (cont'd)

Error Messages (cont'd)

Error Code	Volatile (V) or Nonvolatile (NV)	Message	Recommended Action/Comments
HP-IB HP-IB Errors (cont'd)			
43	V	Codes received while in Talk Only Mode (4.2SP).	Only send codes when the instrument is addressed to listen.
44	NV	Noise Figure Test Set not found when 45.0 SP or 45.1 SP is active.	Refer to the Comments section at the end of this instruction.
45	NV	Plotter was not found on the System Interface Bus at the address specified by 40.3 SP. Or, the HP 8757 Scalar Analyzer was not found on the System Interface Bus at the address specified by 47.4SP.	Refer to the Comments section at the end of this instruction.
46	NV	Pass through device not found on the System Interface Bus or 40.6 SP set incorrectly.	Refer to the Comments section at the end of this instruction.
47	NV	Noise Figure Meter did not find a controller on the System Interface Bus while passing control.	The Noise Figure Meter pass control capability (Special Function 49.1) is not being used, select Special Function 49.0. Also, refer to the comments section at the end of this instruction.
48	NV	Two or more controllers are on the System Interface Bus.	Refer to the Comments section at the end of this instruction.
Service Errors			
60-79	NV	Service-related errors.	Refer to Service-Related Errors in Section VIII, Service. ¹
80	NV	Continuous memory failure.	Refer to Comments below.
Noise Figure Test Set Errors			
100	V	Noise Figure Test Set fine tune table will overflow.	Reduce the number of points by changing the START FREQ, STOP FREQ or STEP SIZE; then, perform a fine tune calibration.
101	NV	Noise Figure Test Set self-test failed.	Refer to Section VIII, Service ¹ and Special Function 98.7.
102	NV	Auto sweep was aborted to protect Noise Figure Test Set switches.	Start sweep again with SWEEP AUTO key. Also, refer to comments.

¹ Section VIII, Service, is in the Service Manual. The part number of the Service Manual is on the title page of this manual.

Error Messages and Recovery (cont'd)

Error Messages (cont'd)

Error Code	Volatile (V) or Nonvolatile (NV)	Message	Recommended Action/Comments
Noise Figure Test Set Errors (cont'd)			
103	NV	Noise Figure Test Set cannot perform a single sideband measurement at this frequency.	Select Special Function 17.1.
104	NV	Interpolating across the Noise Figure Test Set's bands is not permitted.	Ensure that the frequency of interest is a calibrated point.
105	NV	The YIG filter temperature control loop will not lock, inside the Noise Figure Test Set.	Repeat the procedure that was used prior to error E105 being generated. Refer to Section VIII, Service, ¹ for the Noise Figure Meter or the Noise Figure Test Set.
106	NV	Uses selected LO not on the SIB	See chapter 3 Special Functions 96.N

Comments

Error code E19 can be generated for either a coarse or fine tuning calibration of the Noise Figure Test Set. Check all cables and ensure that the LO INPUT, RF INPUT and IF OUTPUT signal paths have been properly connected. If the error occurs after another attempted calibration, the Noise Figure Meter is unable to locate the Noise Figure Test Set's YIG filter passband.

If a fine tune calibration is being performed, a coarse tune calibration may be needed. A coarse tune calibration is needed when the Noise Figure Measurement System is initially put together and the system local oscillator is a sweeper or if repairs are done to the Noise Figure Test Set. Also, if a fine tune calibration is being performed, loss after the Noise Source can cause this error. Some calibration setups, with loss between the Noise Source and the Noise Figure Test Set, may require the use of a preamplifier. It is possible to do a fine tuning calibration with the Noise Source connected directly to the Noise Figure Test Set's INPUT, if a preamplifier is not available. The Noise Source should have at least 12 dB ENR (Excess Noise Ratio) for a fine tuning calibration without a preamplifier. For additional information, refer to the Noise Figure Test Set YIG Filter Calibration Detailed Operating Instruction.

Error code E21 is generated if the current frequency is out of the calibrated measurement range. In Measurement Modes 1.5 through 1.9 the current frequency may be in the calibrated measurement range, but the frequency may not be an actual calibrated frequency. Since corrected measurements are very susceptible to small changes in the system noise figure, it is not advisable to expect good data between calibration points, especially if the points are separated by many megahertz.

Also, because of discontinuities in the band crossings of the Noise Figure Test Set, the Noise Figure Meter cannot interpolate across the Noise Figure Test Set's band crossings. For instance, when one calibration point is in SSB1 and another is in SSB2, a corrected measurement of noise figure and gain would not yield a valid data point that did not require interpolating calibration data for a frequency between the two calibration points.

¹ Section VIII, Service, is in the Service Manual. The part number of the Service Manual is on the title page of this manual.

Error Messages and Recovery (cont'd)

Comments (cont'd)

Special Function 39.1 can be used to disable E21, for interpolated calibration data. Special Function 39.0 (default after a PRESET) enables E21.

Error code E27 usually occurs because the noise figure of the measurement system is too high during the calibration of the third input gain setting at one or more calibration frequency. Either a HP 346B or HP 346C Noise Source is needed for the calibration of an HP 8971C Option 002. The HP 346A will work with the HP 8971C Standard or HP 8971C Option 001. But, the HP 8971C Option 002 requires the addition of approximately 10 dB of gain between the Noise Source and the Noise Figure Meter INPUT connector. Consider the error code as only a warning, and that the ability of the instrument to make valid measurements is most likely not impaired.

If error code E22 occurs during the actual measurement, do one of the following:

1. Increase the instrument's smoothing factor and try to recalibrate.
2. The DUT probably has 30 dB or more of gain, causing the Noise Figure Meter to use the attenuator setting of the third calibration setting. Attach a 10 dB attenuator to the output of the DUT and use special functions 34.3, 34.4, and 34.1 to correct for the loss.
3. Add a preamp to the measurement system and recalibrate.

Error code E28 is generated when the Noise Figure Test Set needs a fine tuning calibration for the current set of frequencies defined by START FREQ, STOP FREQ and STEP SIZE. The calibration can be performed using Special Function 36.3. If a point between those defined by START FREQ, STOP FREQ and STEP SIZE needs to be fine tuned, Special Function 36.4 can be used. The error could have been generated due to the following reasons:

- The YIG filter, in the Noise Figure Test Set, has not been fine tuned at the current frequency and coarse tune data is being used.
- The current frequency of the Noise Figure Test Set YIG filter has been interpolated from the fine tuning calibration data.
- The Noise Figure Test Set has been fine tuned, but the temperature has drifted more than five degrees centigrade, since the last Fine Tuning Calibration. The YIG heater loop must be reset and new fine tuning data gathered. Use Special Function 36.3 to reset the heater loop and gather the new fine tune data.

Usually, the solution to error twenty-eight (E28) is to perform a Fine Tuning Calibration using Special Function 36.3.

Error code E29 is generated if a Noise Figure Test Set coarse tuning calibration is required before making a single sideband measurement within the frequency range of 2401 to 26500 MHz. Special Function 64.0 (refer to the Noise Figure Test Set YIG Filter Calibration Detailed Operating Instruction) must be performed. The Noise Source (HP 346B or HP 346C) must have an ENR (Excess Noise Ratio) of at least 12 dB from 2401 to 26500 MHz to coarse calibrate an HP 8971C Option 002.

Error code E38 is generated when the signal being input to the Noise Figure Test Set does not fall between 10 to 26500 MHz. Check the parameter (START FREQ, STOP

Error Messages and Recovery (cont'd)

Comments (cont'd)

FREQ, STEP SIZE, Special Functions 3.0 or 3.1 and Special Functions 2.0 through 2.3) that may have caused E38 or do a PRESET and re-enter the parameters. Verify that the measurement signal falls between 10 to 26500 MHz.

Error code E42 is generated when the System Local Oscillator is not found at the address specified with Special Function 40.1. Verify that the System Local Oscillator is connected to the SYSTEM INTERFACE BUS connector and not to the HEWLETT-PACKARD INTERFACE BUS (HP-IB) connector. Also, verify that the address of the System Local Oscillator is the same address that is specified with Special Function 40.1.

If the Noise Figure Meter is not going to control the System Local Oscillator, error E42 can be eliminated by using Special Function 46.1. Special Function 46.1 is retained in memory, when the Noise Figure Meter is turned off. The next time it is desired to have the Noise Figure Meter control the System Local Oscillator, Special Function 46.0 will have to be active.

Error code E44 is generated when the Noise Figure Test Set is not found at the address specified by Special Function 40.2. Verify that the Noise Figure Test Set is connected to the SYSTEM INTERFACE BUS connector and not to the HEWLETT-PACKARD INTERFACE BUS connector.

If the Noise Figure Meter is not going to control the Noise Figure Test Set, Special Function 45.2 can be selected to avoid E44. The next time it is desired for the Noise Figure Meter to control the Noise Figure Test Set, Special Function 45.0 or 45.1 will have to be selected.

Error code E45 is generated when the plotter is not found at the address specified by Special Function 40.3. Verify that the plotter is connected to the SYSTEM INTERFACE BUS connector and not to the HEWLETT-PACKARD INTERFACE BUS connector. Also, verify that the address of the plotter is the same as the address specified by Special Function 40.3.

This error can also be generated when the HP 8757 Scalar Analyzer is connected to the System Interface Bus. The error could be a transient situation, which clears itself in five seconds or so, as a result of the untimely interruption of a Noise Figure Meter/Scalar Analyzer conversation. The interruption could be caused by pressing front panel keys or by calculator commands in the middle of a measurement.

If the error doesn't clear itself, follow the steps outlined in the first paragraph for the plotter. With one exception, the address of the Scalar Analyzer is specified using Special Function 47.4.

Error code E46 is generated when the "pass through device" is not found at the address specified by Special Function 40.6 (or HP-IB code PT). Verify that the "pass through device" is connected to the SYSTEM INTERFACE BUS connector and not to the HEWLETT-PACKARD INTERFACE BUS connector. Also, verify that the address of the "pass through device", sent with the PT command, is the valid address of the "pass through device" on the System Interface Bus. The address specified with Special Function 40.6 must be the same as the address sent with the PT command.

Error Messages and Recovery (cont'd)

Comments (cont'd)

Error code E47 is generated when the Noise Figure Meter expects to find a controller on the System Interface Bus and the controller is not found. Error E47 could be caused by Special Function 49.1 being enabled when it is not desired. If Auto-Pass-Control is not desired, select Special Function 49.0 to disable Auto-Pass-Control. If Auto-Pass-Control (Special Function 49.1) should be active, verify, that the other controller is connected to the SYSTEM INTERFACE BUS connector and not to the HEWLETT-PACKARD INTERFACE BUS connector. Also, verify that the address of the controller is the same as the address specified by Special Function 40.5.

Error code E48 is generated when the Noise Figure Meter has detected the existence of another controller on the System Interface Bus; the Noise Figure Meter was told (Special Function 48.0) that it would be the controller. Verify that a controller is connected to the HEWLETT-PACKARD INTERFACE BUS connector and not to the SYSTEM INTERFACE BUS connector.

In systems where there are multiple controllers on the System Interface Bus that are sharing resources such as a local oscillator or a plotter, only one of the controllers should be enabled to be the system controller or active controller at any given time. Verify that the other controllers are not set to be the system controller, at turn-on. If the Noise Figure Meter has been told to be the system controller, it will display "Ctrl on" in the right display after power-on. If the Noise Figure Meter has been told not to be the system controller, the message "Ctrl OFF" will appear in the right displays just after power-on.

Error 48 may also be generated if the HP 8757 Scalar Analyzer is powered-up while connected to the System Interface Bus. First verify that the HP-IB connector on the Scalar Analyzer is connected to the SYSTEM INTERFACE BUS connector on the Noise Figure Meter. If the two instruments are connected correctly, re-initialize the Scalar Analyzer using Special Function 47.2. This should clear error 48.

Error code E80 indicates a continuous memory failure. The instrument may not retain data when powered down. However, the ability of the instrument to make valid measurements may not be impaired. If E80 occurs, press PRESET and proceed. The occurrence of E80 implies that stored information such as the IF attenuator calibration was not retained. Therefore, error code E26 will appear. Perform an IF attenuator calibration (refer to the Calibration, IF Attenuators Detailed Operating Instruction). If E80 persists, service should be performed on the internal battery and related circuits. Refer to Service-Related Errors in Section VIII, Service.¹

Error code E102 indicates that auto sweep has been aborted, in Measurement Modes 1.5 through 1.9. After one hundred sweeps, auto sweep is aborted to protect the switches in the Noise Figure Test Set. To disable auto sweep abort (and error code E102), use Special Function 97.3. PRESET will re-enable auto sweep abort and error code E102.

The following program describes how an error can be displayed in English, over HP-IB:

NOTES

This program was written in BASIC language 3.0 using the HP 9000 Series 200 Model 236 computer.

This program assumes that the Noise Figure Meter has an HP-IB address of 8 and the interface card has a select code of 7. Also, it is assumed that an error has occurred.

¹ Section VIII, Service, is in the Service Manual. The part number of the Service Manual is on the title page of this manual.

Error Messages and Recovery (cont'd)

Comments (cont'd)

```

100 OUTPUT 708;"H1 ER"           !OUTPUT FREQUENCY, INSERTION GAIN
                                  !AND NOISE FIGURE DISPLAYS AND DISPLAY
                                  !THE ERROR.
110 ENTER 708;W1,W2,W3          !GET THE FREQUENCY, INSERTION GAIN AND
                                  !NOISE FIGURE DISPLAYS.
120 PRINT "The last Noise Figure Meter error was: ";W1
130 OUTPUT 708;"FR"           !STOP THE ERROR REPORTING DISPLAY
140 Error_num=W1               !SETUP FOR ERROR READBACK
                                  !
                                  ! THE NEXT LINES ASK FOR THE TEXT OF THE ERROR
                                  ! NUMBER THAT IS CONTAINED IN THE VARIABLE W1.
                                  !
150 OUTPUT 708; "ER ";Error_num;"EN" !SETUP ERROR TEXT TO READ.
160 ENTER 708; Errmes$         !READ THE TEXT.
170 PRINT Errmes$
180 END

```





Related Sections

Calibrate
 Calibration, IF Attenuators
 Calibration, Input Gain Selection
 IF Attenuation Selection
 Measurement Modes 1.1 through 1.9
 Remote Operation, HP-IB
 RF Attenuation Selection
 Service-Related Errors, Section VIII¹
 Special Functions

¹ Section VIII, Service, is in the Service Manual. The part number of the Service Manual is on the title page of this manual.

Fixed Frequency Increment

Description

The tuned frequency of the instrument can be changed by using a combination of the **FREQ INCR**, , and  keys. The **FREQ INCR** key is used to set the fixed increment size. The , and  keys step the fixed frequency up or down by the value of the current frequency increment. These keys provide a convenient method of controlling the fixed frequency of the instrument for applications such as locating the minimum noise figure of an amplifier.

The allowable range of values for a frequency increment is:

- 1 to 1590 MHz (2037 MHz, opt 020) for Measurement Modes 1.0 and 1.4.
- 1 to 26500 MHz for Measurement Modes 1.5 and 1.9
- 1 to 99999 MHz for Measurement Modes 1.1 through 1.3 and 1.6 through 1.8

Fractional increments are rounded to the nearest 1 MHz. If an attempt is made to enter an illegal frequency increment, error code E35 is displayed and the entry is not made.



The Measurement Mode selected determines the fixed frequency increment default. The table below lists the defaults for each of the Measurement Modes.



Measurement Mode	Fixed Frequency Increment
1.0 and 1.4	20 MHz
1.1, 1.2 and 1.3	200 MHz
1.5 and 1.9	250 MHz
1.6, 1.7 and 1.8	500 MHz

As shown in the table, the Measurement Modes have been placed into four groups. If the fixed frequency increment is changed for one Measurement Mode, the fixed frequency increment is changed for all the measurement modes of the group. When going from one measurement mode to another, the fixed frequency increment of the previous measurement mode is automatically saved by the Noise Figure Meter.

Procedure

To change the size of the frequency increment, press the **FREQ INCR** key, enter a value for frequency in MHz, and then press the **ENTER** key.

Use  or  to step the frequency up or down by the current frequency increment.

Front Panel Key	Program Code 	Stored in ¹ Continuous Memory	Can Be Stored and Recalled	Preset (and HP-IB Clear) Conditions	Special Function 0.9 Conditions
FREQ INCR	FN	Y	Y	20 MHz	20 MHz
	UP	—	—	—	—
	DN	—	—	—	—

¹Table categories are described in the Preset Conditions and Power-Up Sequence Detailed Operating Instruction.

Fixed Frequency Increment (cont'd)

Example

To set the frequency increment to 50 MHz:

<p>LOCAL (keystrokes)</p>	<p style="text-align: center;">Function Data Function</p> <p style="text-align: center;"> FREQUENCY 5 0 ENTER </p>
<p>HP-IB (program codes)</p>	<p style="text-align: center;"> FN50MZ Code ——— ——— Data ——— ——— Function </p>

To decrease the tuned frequency by the current frequency increment:

<p>LOCAL (keystrokes)</p>	<p style="text-align: center;">Function</p> <p style="text-align: center;"> ↵ </p>
<p>HP-IB (program codes)</p>	<p style="text-align: center;">DN</p>

Holding either the or key down causes the frequency to step continuously. However, the frequency is slower to change when stepped downward.

Program Codes

HP-IB

In addition to the HP-IB program codes given in Procedure above, HZ and MZ are the program codes for Hz and MHz, respectively.

Indications

The currently programmed frequency increment is displayed in the left display for as long as the **FREQ INCR** key is depressed. After **FREQ INCR** is pressed, the new frequency increment data can be entered. This data is displayed in the left display until the **ENTER** key is pressed. The function is then implemented and the instrument returns to the last selected measurement.

When either or is pressed, the tuned frequency is changed in the selected direction. The new tuned frequency is displayed in the left display and the instrument continues with the selected measurement.

Comments

Front panel frequency increment values should be entered in integer MHz units. If a decimal MHz entry is made, the instrument rounds the entry to the nearest integer (0.5 MHz and above is rounded up).

The Hz unit, provided for HP-IB, is for programmer convenience. The instrument rounds all HP-IB tuned frequency inputs to the nearest MHz.

If or is pressed rapidly in succession, the left display updates the frequency each time the key is pressed. The noise measurement may be delayed (— — — will appear in the **NOISE FIGURE** display), especially if smoothing is used.

Fixed Frequency Increment (cont'd)

**Comments
(cont'd)**

For highest repeatability, always tune in the same manner (direction and step size) as the calibration was done.

**Related
Sections**

Fixed Frequency Tuning
Measurement Modes 1.0 through 1.9
Preset Conditions and Power-Up Sequence

Fixed Frequency Tuning

Description

The FREQUENCY key is used to display the frequency to which the instrument is tuned and to enter a new fixed frequency value. The allowable frequency range is:

- 10 to 1600 MHz (2047 MHz, opt 020) in Measurement Modes 1.5 and 1.9
- 10 to 26500 MHz in Measurement Modes 1.5 and 1.9
- 10 to 99999 MHz in Measurement Modes 1.1 through 1.3 and 1.6 through 1.8

The Measurement Mode determines the default for fixed frequency tuning. The defaults are given in the table below.

Measurement Mode	Fixed Frequency
1.0 and 1.4	30 MHz
1.1, 1.2 and 1.3	10000 MHz
1.5 and 1.9	3000 MHz
1.6, 1.7 and 1.8	46000 MHz

As shown in the table above, the Measurement Modes have been placed into groups. If the fixed frequency is changed for one Measurement Mode, the fixed frequency is changed for all the Measurement Modes of the group. When going from one Measurement Mode to another, the previous fixed frequency is automatically saved by the Noise Figure Meter.

The tuned fixed frequency of the instrument can also be changed by using a combination of the **FREQ INCR** key to set the increment size, and the **▲** and **▼** keys to step the fixed frequency in the selected direction.

The FREQUENCY key acts as a “clear entry” key. It clears entries in progress, returns the instrument to the last selected measurement with the left display showing the current tuned frequency, and halts the sweep if it is in progress.

Procedure

To display the current tuned frequency and enter a new tuned frequency, press FREQUENCY, enter the value of the new frequency in MHz, and press ENTER.

Front Panel Key	Program Code HP-IB	Stored in ¹ Continuous Memory	Can Be Stored and Recalled	Preset (and HP-IB Clear) Conditions	Special Function 0.9 Conditions
FREQUENCY	FR	Y	Y	30 MHz	30 MHz

¹Table categories are described in the Preset Conditions and Power-Up Sequence Detailed Operating Instruction.

Fixed Frequency Tuning (cont'd)

Example

To tune the instrument to a new frequency of 100 MHz:

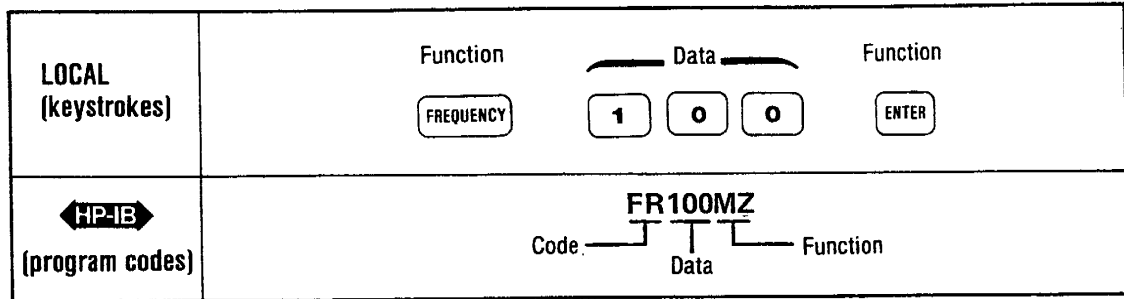

Program Codes



The HP-IB program code for FREQUENCY is FR. The program codes for Hz and MHz are HZ and MZ.

Indications

Pressing the FREQUENCY key clears an incomplete entry, displays the current tuned frequency, and enables the entry of a new tuned frequency. As the entry numbers are pressed, the specific numbers appear in the left display. When ENTER is pressed, the instrument is tuned to the specified frequency and the instrument continues to make the the last selected measurement.

Comments

Front panel frequency entries should be made in integer MHz units. If a decimal MHz entry is made, the instrument rounds the entry to the nearest integer (0.5 MHz and above is rounded up).

The Hz unit, provided for HP-IB, is for programmer convenience. The instrument rounds all HP-IB tuned frequency inputs to the nearest MHz.

If no other prefix key has been pressed, any digits entered followed by ENTER will be interpreted as if the FREQUENCY key were the prefix.

For highest repeatability, always tune in the same manner (direction and step size) as the calibration was done.

Related Sections

- Fixed Frequency Increment
- Measurement Modes 1.0 through 1.9
- Preset Conditions and Power-Up Sequence

Fixed IF or LO Frequency Selection

(Special Functions 3 and 19)

Description

Special Function 3 displays and allows entry of the fixed IF and LO frequencies. This special function is used when the measurement signal is down converted prior to being input to the Noise Figure Meter (Measurement Modes 1.1 through 1.4) or the Noise Figure Test Set (Measurement Modes 1.6 through 1.9).

Special Function 19 is ONLY used in Measurement Modes 1.5 through 1.9. Special Function 19 displays and allows the user to change the internal IF between the Noise Figure Meter and the Noise Figure Test Set. The internal IF can only be changed when the measurement frequency is between 1601 and 26500 MHz.

Special Function 3.0 is used to display and enter the fixed IF for the Measurement Modes 1.1, 1.3, 1.6 and 1.8. If no entry is made, the Noise Figure Meter uses the last entered value. The fixed IF value does not apply when the instrument is operated in Measurement Modes 1.0, 1.2, 1.4, 1.5, 1.7 or 1.9. The allowable range of values for IF entries is 10 to 1600 MHz; 2047 MHz, opt 020 (Measurement Modes 1.1 and 1.3) or 10 to 26500 MHz (Measurement Modes 1.6 and 1.8).

Special Function 3.1 is used to display and enter the fixed local oscillator frequency for Measurement Modes 1.2, 1.4, 1.7 and 1.9. If no entry is made, the Noise Figure Meter uses the last entered value. If the instrument is operated in Measurement Modes 1.0, 1.1, 1.3, 1.5, 1.6 or 1.8, the fixed local oscillator frequency does not apply. The allowable range of values for the local oscillator is 10 to 99999 MHz (Measurement Modes 1.7 and 1.9) and 0 to 99999 MHz (Measurement Modes 1.2, 1.4, 1.7 and 1.9).

Special Function 3.2 is used to display the user controlled local oscillator frequency in Measurement Modes 1.6 through 1.9. Special Function 3.2 is particularly useful in Measurement Modes 1.6 and 1.8. The frequency that the user controlled local oscillator should be set to is displayed. If zero is displayed, an error exists with the Special Function 3 frequency and Special Function 2 frequency mix.

Special Functions 19.2 through 19.4 are used when the Noise Figure Test Set is configured with the Noise Figure Meter. These special functions are used to change the internal IF between the Noise Figure Meter and the Noise Figure Test Set. Special Functions 19.2 through 19.4 can only be used when the measurement frequency is greater than 1601 MHz. The default IFs, for Special Functions 19.2 through 19.4, have been carefully chosen; only small deviations from the defaults should be used and only if the particular measurement requires that the default be changed.

Special Function 19.5 is used to display the current frequency (IF) that is being input to the Noise Figure Meter.

Front panel frequency entries should be made in integer MHz units. If a decimal MHz entry is made, the instrument rounds the entry to the nearest integer (0.5 MHz and above are rounded up).

Fixed IF or LO Frequency Selection (cont'd)

(Special Functions 3 and 19)

Procedure

To select a fixed IF or LO frequency, key in the corresponding Special Function code and then press the SPECIAL FUNCTION key. Next, enter the appropriate value using the DATA keys and press ENTER.

Special Function		Program Code HP-IB	Lights Special ¹ Function Key	Stored in Con- tinuous Memory	Can be Stored and Recalled	Special Function 0.0 Conditions	Preset (and HP-IB Clear) Conditions	Special Function 0.9 Conditions
Description	Code							
Fixed IF (for modes 1.1 and 1.3) (for modes 1.6 and 1.8)	3.0	IF or 3.0SP	N	Y	Y	NC	30 MHz	30 MHz
Fixed LO Frequency (for modes 1.2 and 1.4) (for modes 1.7 and 1.9)	3.1	LF or 3.1SP	N	Y	Y	NC	10 000 MHz	10000 MHz
Display User Controlled LO frequency in Measurement Modes 1.6 through 1.9	3.2	UL or 3.2SP	N	N	N	OFF	OFF	OFF
Fixed IF for Noise Figure Test Set band 2 (SSB2)	19.2	S2 or 19.2SP	N	Y	Y	NC	700 MHz	700 MHz
Fixed IF for Noise Figure Test Set band 3 (SSB3)	19.3	S3 or 19.3SP	N	Y	Y	NC	450 MHz	450 MHz
Fixed IF for Noise Figure Test Set band 4 (DSB)	19.4	S4 or 19.4SP	N	Y	Y	NC	25 MHz	25 MHz
Display Noise Figure Meter input frequency.	19.5	S5 or 19.5SP	N	N	N	NC	NC	NC

¹Table categories are explained in the Special Function Detailed Operation Instruction.

Example

To select a fixed IF of 70 MHz:

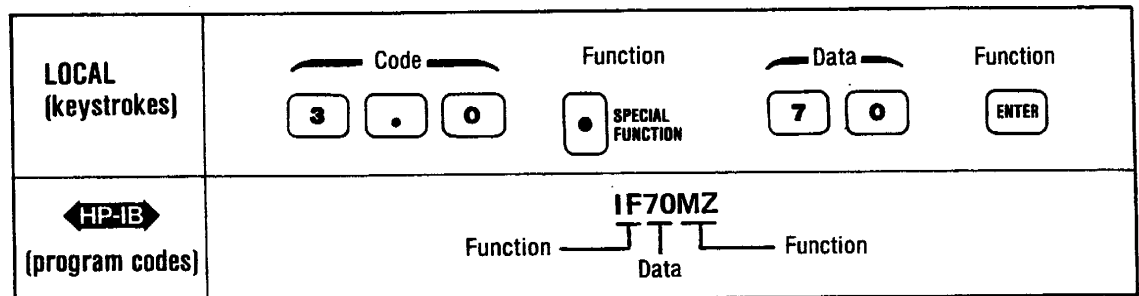

Fixed IF or LO Frequency Selection (cont'd)

(Special Functions 3 and 19)

Program Codes

HP-IB

The HP-IB codes for Hz and MHz are HZ and MZ, respectively. For Special Functions 3 and 19 program codes, refer to Procedure.

Indications

When Special Function 3.0, 3.1 or 19.2 through 19.4 is selected, the left display shows the current IF or LO frequency. When a new frequency value is entered, it appears in the left display only for as long as the ENTER key is depressed. When the ENTER key is released, the left display returns to the display that was present when the special function was entered.

When Special Function 19.5 is selected, the left display shows the current frequency being input to the Noise Figure Meter. The display is cleared by pressing the FREQUENCY key.

Comments

If error code E32 is displayed when attempting to enter a fixed LO frequency, the entered frequency is outside the range specified for the LO. If the entered frequency was incorrect, re-enter the correct frequency. If the LO frequencies are incorrect, they can be changed using either Special Function 42.3 or 42.4 (refer to Programming the System LO Detailed Operating Instruction).

The Hz unit, provided for HP-IB, is for programmer convenience. The instrument rounds all HP-IB tuned frequency inputs to the nearest MHz.

Related Sections

Error Messages and Recovery
Measurement Modes 1.1 through 1.9
Programming the System LO
Special Functions

HP-IB and System Interface Bus (SIB) Addresses (Special Function 40, 47 and 96)

Description

HP-IB

There are two HP-IB and eight SIB (System Interface Bus) addresses.

The two HP-IB addresses are really both addresses of the Noise Figure Meter. One address is the address of the Noise Figure Meter. The other address is called the "Pass Through Address" of the Noise Figure Meter. The "Pass Through Address" is used when an external controller on the Hewlett-Packard Interface Bus (HP-IB) wants to control a device on the System Interface Bus (SIB). The Pass Through Address is set up automatically by the Noise Figure Meter, only after Pass Through Mode has been initialized using Special Function 40.6 (or HP-IB code PT). The Pass Through Address is one greater than the Noise Figure Meter's address if it is even and is one less than the Noise Figure Meter's address if it is odd. Refer to the System Interface Bus Control Detailed Operating Instruction for more information about Pass Through Mode and the Pass Through Address.

Special Function 40.7 can be used to display the Pass Through Address.

The eight SIB addresses are listed below:

- System Local Oscillator
- Noise Figure Test Set
- Plotter
- User Controlled Local Oscillator
- System Interface Bus
- Pass Through Device
- Pass Control
- HP 8757 Scalar Analyzer

The System Local Oscillator is used with the Noise Figure Meter in Measurement Modes 1.1 through 1.4 and the Noise Figure Meter and Noise Figure Test Set in Measurement Modes 1.5 through 1.9.

The Noise Figure Test Set is configured with the Noise Figure Meter in Measurement Modes 1.5 through 1.9 to extend the frequency range of the Noise Figure Meter.

The plotter is connected to the System Interface Bus to give a permanent record of a noise figure or gain measurement.

The user controlled local oscillator is used with the Noise Figure Measurement System (Noise Figure Meter, Noise Figure Test Set and System Local Oscillator) in Measurement Modes 1.6 through 1.9. Along with a mixer or the device under test, the user controlled local oscillator provides the first level of frequency conversion.

The system interface bus address is the address of the System Interface Bus (SIB) connector on the back of the Noise Figure Meter. This address only needs to be changed if some other instrument on the System Interface Bus has to use the default address that has been set up for the System Interface Bus.

The pass through device address is used in Pass Through Mode. The pass through device address selects an instrument on the System Interface Bus that is going to be controlled by an external controller connected to the Hewlett-Packard Interface Bus (HP-IB). For more information on using Pass Through Mode and the pass through device address, refer to the System Interface Bus Control Detailed Operating Instruction.

The pass control address is the address of the controller that will alternate control responsibilities with the Noise Figure Meter. The two instruments will alternate control on the System Interface Bus. This is an advanced capability and does not need to be set under normal circumstances.

HP-IB and System Interface Bus (SIB) Addresses (cont'd) (Special Function 40, 47 and 96)

Description
HP-IB
(cont'd)

The HP 8757 Scalar Analyzer is connected to the System Interface Bus for a calibrated visual representation of a noise figure and/or gain measurement.

The HP-IB and SIB addresses can be displayed and changed by Special Functions 40, 47 and 96. The selected address is displayed in decimal in the left display. The decimal value of the factory set addresses are as shown below:

- Noise Figure Meter=8
- Pass Control Address=16
- System Local Oscillator=19
- Noise Figure Test Set=10
- Plotter=5
- System Interface Bus=8
- Pass Through Device (There isn't any factory set address.)
- User Controlled LO=20
- HP 8757 Scalar Analyzer=16

A list of allowable addresses is given below.

ASCII Address Codes		Decimal Equivalents
LISTEN	TALK	
SP	@	00
!	A	01
"	B	02
#	C	03
\$	D	04
%	E	05
&	F	06
'	G	07
(H	08
)	I	09
*	J	10
+	K	11
,	L	12
-	M	13
.	N	14
/	O	15
0	P	16
1	Q	17
2	R	18
3	S	19
4	T	20
5	U	21
6	V	22
7	W	23
8	X	24
9	Y	25
:	Z	26
;	[27
<	\	28
=]	29
>	^	30

HP-IB and System Interface Bus (SIB) Addresses (cont'd)

(Special Function 40, 47 and 96)

Procedure

To display the current HP-IB or SIB address, key in the corresponding Special Function code and then press the SPECIAL FUNCTION key.

To change an HP-IB or SIB address, first display the current address. Then, enter a decimal number from 0 to 30 for the new address and press the ENTER key.

Special Function		Program Code ◀ HP-IB ▶	Lights Special ¹ Function Key	Stored in Continuous Memory	Can be Stored and Recalled	Special Function 0.0 Conditions	Preset (and HP-IB Clear) Conditions	Special Function 0.9 Conditions
Description	Code							
Noise Figure Meter HP-IB Address	40.0	None	N	Y	N	NC	NC	8
System LO SIB Address	40.1	EA or 40.1SP	N	Y	N	NC	NC	19
Noise Figure Test Set SIB Address	40.2	HT or 40.2SP	N	Y	N	NC	NC	10
Plotter SIB Address	40.3	HP or 40.3SP	N	Y	N	NC	NC	5
System Interface Bus Address	40.4	HS or 40.4SP	N	Y	N	NC	NC	8
Pass Control SIB Address	40.5	HC or 40.5SP	N	Y	N	NC	NC	16
Pass Through Device SIB Address	40.6	PT or 40.6SP	N	Y	N	NC	NC	NC
Display the Noise Figure Meter's Pass Through Address	40.7	VP or 40.7SP	N	N	N	NC	NC	Off
HP 8757 Scalar Analyzer SIB Address	47.4	ZR or 47.4SP	N	N	N	NC	16	16
User Controlled LO SIB Address	96.2	None	N	Y	N	NC	NC	20

¹Table categories are explained in the Special Function Detailed Operation Instruction.

Example

To display the system LO address and change it to 20:

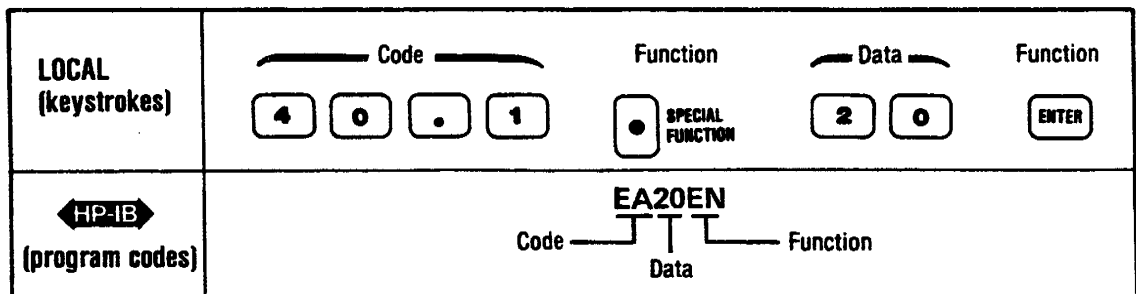

HP-IB and System Interface Bus (SIB) Addresses (cont'd)

(Special Function 40, 47 and 96)

Program Codes ▶HP-IB◀	The program code to display the SIB address of the system LO is EA. The system LO address can be changed by entering a decimal number from 0 to 30 and then EN (the program code for ENTER). The other addresses are changed in a similar manner. The HP-IB address of the Noise Figure Meter cannot be read or changed over the HP-IB.
Indications	The HP-IB or SIB address of the corresponding special function appears in the left display when Special Function 40 is selected. When an address is changed, the new address appears in the left display for as long as the ENTER key is depressed. When the ENTER key is released, the instrument returns to the last selected measurement.
Comments	Do not set the Noise Figure Meter address equal to any of the other addresses.
Related Sections	Controller Capability of the Noise Figure Meter Remote Operation, HP-IB Special Functions

IF Attenuation Selection (Special Functions 70, 71, and 72)

Description

IF attenuation selection, display, and hold are available in all measurement modes. It should be noted, however, that only the hold capability (Special Function 72.0) is normally used by most operators. The hold is required during manual measurements (refer to the Manual Measurements Detailed Operating Instruction for additional information). The selection and display of specific IF attenuation settings are more likely to be used during adjustment procedures, performance tests, or troubleshooting procedures. In some specialized applications these capabilities can be helpful, but care must be exercised when using them. It is possible to introduce some very subtle errors in the measurements that the Noise Figure Meter may not be able to guard against. Additional information on how to use and interpret these Special Functions is contained in Section VIII, Service¹.

Procedure

To select a specific IF attenuation setting, display, or hold, key in the corresponding Special Function code and then press the SPECIAL FUNCTION key.

Special Function		Program Code HP-IB	Lights Special ¹ Function Key	Stored in Con- tinuous Memory	Can be Stored and Recalled	Special Function 0.0 Conditions	Preset (and HP-IB Clear) Conditions	Special Function 0.9 Conditions
Description	Code							
IF Attenuation Selection								
Auto	70.0	I0 or 70.0SP	N	N	N	On	On	On
0 dB	70.1	I1 or 70.1SP	Y	N	N	Off	Off	Off
5 dB	70.2	I2 or 70.2SP	Y	N	N	Off	Off	Off
10 dB	70.3	I3 or 70.3SP	Y	N	N	Off	Off	Off
15 dB	70.4	I4 or 70.4SP	Y	N	N	Off	Off	Off
20 dB	70.5	I5 or 70.5SP	Y	N	N	Off	Off	Off
25 dB	70.6	I6 or 70.6SP	Y	N	N	Off	Off	Off
30 dB	70.7	I7 or 70.7SP	Y	N	N	Off	Off	Off
35 dB	70.8	I8 or 70.8SP	Y	N	N	Off	Off	Off
Display IF Attenuator Settings								
Display IF Attenuator	71.0	SI or 71.0SP	N	N	N	Off	Off	Off
IF Attenuator Hold								
IF Attenuator Hold	72.0	IH or 72.0SP	Y	N	N	Off	Off	Off
¹ Table categories are explained in the Special Functions Detailed Operating Instruction.								

¹ Section VIII, Service, is in the Service Manual. The part number of the Service Manual is on the title page of this manual.

IF Attenuation Selection (cont'd)

(Special Functions 70, 71, and 72)

Example To select the IF attenuator hold function:

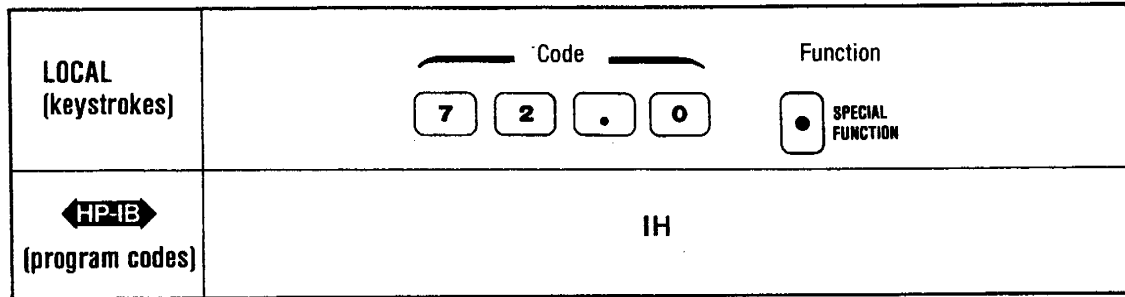

Program Codes



For HP-IB codes, refer to Procedure.

Indications

When Special Function 71 is implemented, three digits appear in the left display. The digits are either "1" (yes) or "0" (no) to indicate whether or not the corresponding attenuator is switched into the 20 MHz IF Assembly circuits (see Service Sheets 3 and 4 in Section VIII, Service¹). The first (most significant) digit represents 20 dB. The second digit represents 10 dB. The third (least significant) digit represents 5 dB. To obtain the IF attenuator setting, add the attenuation that is represented by each digit. For example, a display of "1 0 1" indicates an IF attenuator setting of 25 dB.

The following table lists the IF attenuation available (Special Function 70.1 through 70.8) and the ones (1) and zeros (0) that are displayed using Special Function 71.0.

Attenuation (dB)	Special Function	Attenuator		
		20 dB	10 dB	5 dB
0	70.1	0	0	0
5	70.2	0	0	1
10	70.3	0	1	0
15	70.4	0	1	1
20	70.5	1	0	0
25	70.6	1	0	1
30	70.7	1	1	0
35	70.8	1	1	1

Comments

If any of the 60 or 70 series of Special Functions (except 60.0 and 70.0) are active, the calibration sequence does not override them. Therefore, to calibrate on one range only, use any of these Special Functions except 60.0 or 70.0. It is also true that if any of these Special Functions are inadvertently active, the calibration sequence will not cover the expected gain range.

Related Sections

- Calibrate
- Manual Measurements
- RF Attenuation Selection
- Special Functions

¹ Section VIII, Service, is in the Service Manual. The part number of the Service Manual is on the title page of this manual.

Loss Compensation (Special Function 34)

Description

Special Function 34 corrects for loss between the noise source and the device under test (DUT), and the DUT and the Noise Figure Meter. The loss in dB and the temperature of the loss must be entered prior to enabling loss compensation (Special Function 34.1) or else the default values of 0 dB and 0K are used.

The temperature of the loss is the ambient temperature. Therefore, both the loss before the DUT and the loss after the DUT are assumed to be at the same temperature. Only one temperature can be entered for both losses. The temperature of the loss can be entered in Kelvins, degrees Fahrenheit, or degrees Celsius. Temperature units are selected by Special Function 11.

The allowable range of loss in Kelvins is 0 to 9999. The allowable range of loss in dB is -100 to +100.

Procedure

To display, enter, or enable loss compensation, key in the corresponding Special Function code and then press the SPECIAL FUNCTION key.

Special Function		Program Code HP-IB	Lights Special ¹ Function Key	Stored in Con- tinuous Memory	Can be Stored and Recalled	Special Function 0.0 Conditions	Preset (and HP-IB Clear) Conditions	Special Function 0.9 Conditions
Description	Code							
Turn loss compensation off.	34.0	LO or 34.0SP	N	Y	N	On	On	On
Turn loss compensation on.	34.1	L1 or 34.1SP	Y	Y	N	Off	Off	Off
Display and enter the amount of loss between the noise source and the DUT in dB.	34.2	LA or 34.2SP	N	Y	N	NC	0 dB	0 dB
Display and enter the temperature of losses (units are determined by Special Function 11).	34.3	LT or 34.3SP	N	Y	N	NC	0K	0K
Display and enter the amount of loss between the DUT and the Noise Figure Meter in dB.	34.4	LB or 34.4SP	N	Y	N	NC	0 dB	0 dB

¹Table categories are explained in the Special Functions Detailed Operating Instruction.

Loss Compensation (cont'd)

(Special Function 34)

Example

To compensate for a loss of 3 dB between the noise source and the DUT at a temperature of 290K (assume Special Function 11.0 is active — temperature in K) and to enable the loss compensation function:

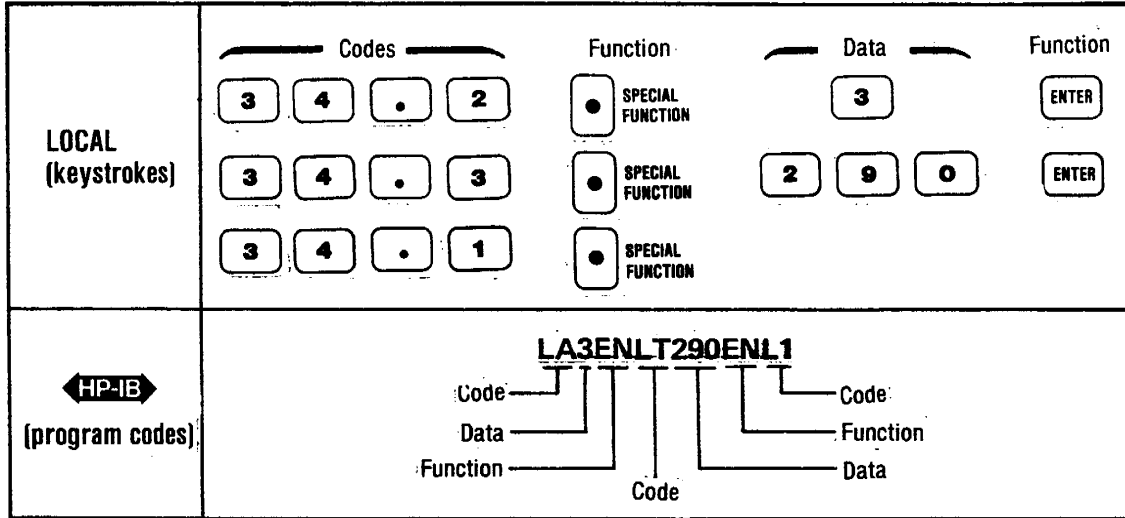

Program Codes



For HP-IB codes, refer to Procedure above.

Indications

If Special Function 34.0 or 34.1 is selected, the left display returns to the previously selected display. The INSERTION GAIN and NOISE FIGURE displays are not affected by this function.

Comments

When a loss compensation entry is made in dB, the temperature of the loss should also be entered.

The Noise Figure Meter assumes that the loss was not present during calibration.

If a 2 dB attenuator is being used in the measurement, 2 dB would be entered as the loss. If the loss varies with frequency, the ENR table can be modified to provide proper compensation. In order to do this, enter a new ENR table in which the effective ENR at each frequency has been determined by subtracting the loss (at that frequency) from the noise source ENR. Although this assumes the noise source and the loss are at the same temperature the following example shows that for loss cases, the resultant error is negligible.

For typical adapter losses of < 0.5 dB and a noise source 5 deg K (actually warmer than usual) hotter than the adapter, the difference between the actual combined cold temperature (T cold combined) and the temperature on the bulkhead of the noise source is only 0.54 deg K. This is derived from the following equation:

$$T_{new} = T_{ns} * loss + (1-loss) * T_{loss}$$

where the losses are in linear terms i.e. 10^(losses_dB/10) and the temperatures are in Kelvin.

The error in noise figure caused by the -0.54 K error in T cold is less than 0.01 dB for a DUT with a one dB noise figure.

Related Sections

- Special Functions
- Temperature Units Selection

Manual Measurement Functions (Special Functions 14 and 15)

Description

The manual measurement functions calibrate and measure noise figure using a thermal (hot/cold) noise source. They also can be used to display either the current measurement or the result of the manual measurement. Manual measurement functions are used for fixed frequency measurements only.

Three general requirements must be understood when performing manual measurements:

1. A stable reading must be stored in the Noise Figure Meter's memory prior to disconnecting the noise source. This stable reading can be obtained by either activating the next manual measurement special function or by using the Trigger Selection Special Function (30). Since activating the next special function requires fewer keystrokes, that is the method used in the example shown in this instruction.
2. The device under test (DUT) must first be connected to the measurement system and the proper RF attenuation level determined. The RF attenuators must then be held fixed (Special Function 62) for the entire manual measurement.
3. The IF attenuators must be held fixed (Special Function 72) during the two measurement readings (noise source off and on) and again during the two calibration readings (noise source off and on). However, the IF attenuators must be allowed to autorange when switching between calibration and measurements, and vice versa.

Procedure

To measure, calibrate, or display manual measurements, key in the corresponding Special Function code and then press the SPECIAL FUNCTION key.

Special Function		Program Code HP-IB	Lights Special ¹ Function Key	Stored In Con- tinuous Memory	Can be Stored and Recalled	Special Function 0.0 Conditions	Preset (and HP-IB Clear) Conditions	Special Function 0.9 Conditions
Description	Code							
Make cold measure- ments (source off)	14.1	MC or 14.1SP	N	Y	Y	Off	Off	Off
Make hot measure- ments (source on).	14.2	MH or 14.2SP	N	Y	Y	Off	Off	Off
Perform cold calibra- tion (source off).	14.3	CC or 14.3SP	N	Y	Y	Off	Off	Off
Perform hot calibra- tion (source on).	14.4	CH or 14.4SP	N	Y	Y	Off	Off	Off
Normal display mode.	15.0	P0 or 15.0SP	N	N	Y	On	On	On
Display manual meas- urement results.	15.1	P1 or 15.1SP	Y	N	Y	Off	Off	Off

¹Table categories are explained in the Special Functions Detailed Operating Instruction.

Manual Measurement Functions (cont'd)

(Special Functions 14 and 15)

Example

The following example is a general procedure for making manual measurements. It may be necessary to determine the requirements of a specific application and make the necessary changes to obtain the best measurement results. For example, it is possible to make manual measurements using an external controller. Additional information on this method is contained in the Comments section of this instruction.

Find and Hold the RF Attenuation

- a. Enter the required parameters for the Measurement Mode that is going to be used.
- b. Connect the hot noise source to the DUT input. Connect the DUT output to the measurement system setup.
- c. Press 1 4 . 2 SPECIAL FUNCTION to obtain the noise power.
- d. Press 6 2 . 0 SPECIAL FUNCTION to hold the RF attenuation setting. The RF attenuation is held at this setting for the entire measurement.

Calibrate

- e. Remove the DUT and connect the hot noise source to the measurement system setup.
- f. Press 1 4 . 4 SPECIAL FUNCTION to calibrate the measurement system for the hot noise source.
- g. Press 7 2 . 0 SPECIAL FUNCTION to hold the IF attenuation setting.
- h. Press 1 4 . 3 SPECIAL FUNCTION to store the hot noise source calibration reading and to select the cold noise source calibration. Note that while the cold noise source calibration is selected, the results are not stored until after the cold noise source is connected and Special Function 14.2 is activated in step j.
- i. Remove the hot noise source and connect the cold noise source to the measurement system setup.
- j. Press 1 4 . 2 SPECIAL FUNCTION to select the hot noise source measurement and to store the cold noise source calibration reading.

Measure, then Calculate and Display Noise Figure

- k. Connect the hot noise source to the DUT and the DUT to the measurement system setup.
- l. Press 7 0 . 0 SPECIAL FUNCTION to allow the IF attenuators to autorange.
- m. Press 7 2 . 0 SPECIAL FUNCTION to hold the IF attenuation fixed at the new value.
- n. Press 1 4 . 1 SPECIAL FUNCTION to select the cold noise source measurement and to store the hot noise measurement reading.
- o. Disconnect the hot noise source from the DUT and connect the cold noise source to the DUT.

Manual Measurement Functions (cont'd)

(Special Functions 14 and 15)

Example (cont'd)

p. Press 15.1 SPECIAL FUNCTION to calculate and display the manual measurement noise figure result. Verify that the LED in the SPECIAL FUNCTION key lights when this special function is activated. The Noise Figure Meter continues to make cold noise source measurements and update the display.

NOTE

The calibration data remains stored. Therefore, if another DUT is to be tested immediately, it is only necessary to press 14.2 SPECIAL FUNCTION and repeat steps k through p. To exit manual measurements and return to the normal display, press 15.0 SPECIAL FUNCTION and then press UNCORRECTED NOISE FIGURE.

Program Codes

HP-IB

For HP-IB codes, refer to Procedure above.

Indications

When Special Functions 15.0 and any 14.N are selected, no unit annunciators are lit in the NOISE FIGURE display. The number displayed is the power into the detector in mW.

Comments

When Special Function 15.1 is selected, UNCORRECTED NOISE FIGURE, CORRECTED NOISE FIGURE AND GAIN, or any noise figure display unit (Special Function 10) can be selected.

Another way to ensure that stable readings are stored in the Noise Figure Meter's memory during Manual Measurements is to use the Trigger Hold Special Function (30.1) and Trigger Execute Special Function (30.2). In this type of operation only one measurement is taken and stored. Therefore, it is not critical if the equipment is disconnected prior to switching Manual Measurement Special Functions.

Related Sections

IF Attenuation Selection
RF Attenuation Selection
Special Functions
Trigger Selection



3-124 This Page Intentionally Left Blank

Measurement Modes (Special Function 1)

Description

The Noise Figure Meter has ten Measurement Modes available. Each Measurement Mode, 1.0 through 1.9, is described individually in a separate Detailed Operating Instruction. This discussion covers the capabilities and differences of the individual modes. The following table lists the modes and shows their status in different instrument operations.

Special Function		Program Code HP-IB	Lights Special ¹ Function Key	Stored in Continuous Memory	Can be Stored and Recalled	Special Function 0.0 Conditions	Preset (and HP-IB Clear) Conditions	Special Function 0.9 Conditions
Description	Code							
Measurement Mode 1.0—10 to 1600 MHz (2047 MHz, opt 020)	1.0	E0	N	Y	Y	On	On	On
Measurement Mode 1.1—variable frequency system LO; fixed IF	1.1	E1	N	Y	Y	Off	Off	Off
Measurement Mode 1.2—fixed frequency system LO; variable IF; SSB	1.2	E2	N	Y	Y	Off	Off	Off
Measurement Mode 1.3—variable frequency system LO; fixed IF; mixer in DUT	1.3	E3	N	Y	Y	Off	Off	Off
Measurement Mode 1.4—fixed frequency system LO; variable IF; mixer in DUT	1.4	E4	N	Y	Y	Off	Off	Off
Measurement Mode 1.5—10 to 26500 MHz	1.5	E5	N	Y	Y	Off	Off	Off
Measurement Mode 1.6—variable frequency user controlled LO; fixed IF	1.6	E6	N	Y	Y	Off	Off	Off
Measurement Mode 1.7—fixed frequency user controlled LO; variable IF; SSB	1.7	E7	N	Y	Y	Off	Off	Off
Measurement Mode 1.8—variable frequency user controlled LO; fixed IF; mixer in DUT	1.8	E8	N	Y	Y	Off	Off	Off
Measurement Mode 1.9—fixed frequency user controlled LO; variable IF; mixer in DUT	1.9	E9	N	Y	Y	Off	Off	Off

¹Table categories are explained in the Special Functions Detailed Operating Instruction.

Measurement Modes (cont'd)

(Special Function 1)

Description (cont'd)

The following definitions will be helpful when using the different Measurement Modes:

System Local Oscillator—The System Local Oscillator is used in Measurement Modes 1.1 through 1.9, is connected to the SYSTEM INTERFACE BUS connector and is controlled by the Noise Figure Meter. The System Local Oscillator is used for frequency conversion in Measurement Modes 1.1 through 1.4 and is part of the Noise Figure Measurement System (Noise Figure Meter, Noise Figure Test Set and System Local Oscillator) in Measurement Modes 1.5 through 1.9.

User Controlled Local Oscillator—The User Controlled Local Oscillator is ONLY used in Measurement Modes 1.6 through 1.9. The User Controlled Local Oscillator is used for frequency conversion. In the Measurement Modes, the examples assume that the user controlled LO is being controlled by the user and not by the Noise Figure Meter. However, the Noise Figure Meter can control the user controlled LO to a limited extent. The limited control capability is explained in the Comments section at the end of Measurement Modes 1.6 through 1.9. If the user controlled LO is being controlled by the user, the LO is connected to the HP-IB connector. When the user controlled LO is being controlled by the Noise Figure Meter, the LO is connected to the System Interface Bus (SIB) connector.

The ten Measurement Modes can be divided into the following three subsets:

a. Measurement Mode 1.0 is a stand alone mode with no external mixer or system local oscillator required and no frequency conversion in the device under test. The frequency range in this mode is 10 to 1600 MHz (2047 MHz, opt 020).

Measurement Mode 1.5 is similar to Measurement Mode 1.0. Measurement Mode 1.5 requires the use of the HP 8971C Noise Figure Test Set and a system local oscillator. The Noise Figure Meter, Noise Figure Test Set and system local oscillator form the HP 8970S Noise Figure Measurement System. The Noise Figure Meter controls the Noise Figure Test Set and the system local oscillator. This mode does not require the use of an external mixer (that is, external to the system) or second local oscillator. There is no frequency conversion in the device under test. The frequency range in this mode is 10 to 26500 MHz.

b. Measurement Modes 1.1 and 1.3 both require a variable frequency system local oscillator and an external mixer. Measurement Modes 1.6 and 1.8 both require the Noise Figure Measurement System (Noise Figure Meter, Noise Figure Test Set and system local oscillator), external mixer and user controlled local oscillator. The Noise Figure Meter can be used to control the system local oscillator (Measurement Modes 1.1 and 1.3) and is used to control the Noise Figure Measurement System (Measurement Modes 1.6 and 1.8). The Noise Figure Meter controls the system local oscillator as directed by the system local oscillator program (Special Function 41 or 42). Measurement Modes 1.1 and 1.3 down convert the measurement frequency to 10 to 1600 MHz (2047 MHz, opt 020), Measurement Modes 1.6 and 1.8 down convert the measurement frequency to 10 to 26500 MHz. Measurement Modes 1.1 and 1.6 have no down conversion in the Device Under Test (DUT; for example, an amplifier or transistor). Measurement Modes 1.3 and 1.8 do provide for down conversion in the DUT (for example, a mixer or receiver).

c. Measurement Modes 1.2 and 1.4 require a fixed frequency system local oscillator and an external mixer. Measurement Modes 1.7 and 1.9 require the Noise Figure Measurement System (Noise Figure Meter, Noise Figure Test Set and system local oscillator), an external mixer and fixed user controlled local oscillator. The Noise

Measurement Modes (cont'd)

(Special Function 1)

Description (cont'd)

Figure Meter can be used to control the system local oscillator (Measurement Modes 1.2 and 1.4) and is used to control the Noise Figure Measurement System (Measurement Modes 1.7 and 1.9). The Noise Figure Meter controls the system local oscillator as directed by the system local oscillator program (Special Function 41 or 42). Measurement Modes 1.2 and 1.4 down convert the measurement frequency to 10 to 1600 MHz (2047 MHz, opt 020). Measurement Modes 1.7 and 1.9 down convert the measurement frequency to 10 to 26500 MHz. Measurement Modes 1.2 and 1.7 have no down conversion in the DUT (for example, an amplifier or transistor). Measurement Modes 1.4 and 1.9 do provide for down conversion in the DUT (for example, a mixer or receiver. Modes 1.2 and 1.7 must be a single sideband measurement. Additional information on sideband selection is covered later in this instruction and in the Sideband Selection Detailed Operating Instruction.

For a summary of the ten Measurement Modes, refer to the Measurement Modes Summary table.

The calibration and measurement setups and procedures are illustrated and specific examples are provided in the Detailed Operating Instructions for Measurement Modes 1.0 through 1.9.

Signal Comparison

In the following discussion, signals present at different points in the measurement system are compared for the different measurement modes. The following signal points are covered:

- a. The output of the noise source (for example the HP 346B).
- b. The output of the system LO (Measurement Modes 1.1—1.4) and the user controlled LO (Measurement Modes 1.6—1.9).
- c. The measurement bandwidth of the Noise Figure Meter (Noise Figure Measurement System) as seen looking back into the mixer (translated to the frequency range of the system LO (Measurement Modes 1.1—1.4) and user controlled LO (Measurement Modes 1.6—1.9)).
- d. The input to the Noise Figure Meter (Noise Figure Test Set).

The noise source output is the same for all modes. For a noise source with a nominal Excess Noise Ratio (ENR) of 15.2 dB, the output is broadband random noise varying between approximately -158.8 dBm/Hz when on (hot) and -174 dBm/Hz when off (cold). The ENR of the noise source varies slightly over the frequency range of 10 to 26500 MHz. This variation in power level is compensated for in the Noise Figure Meter using the specific information entered into the ENR tables. Refer to the ENR Table Entry Detailed Operating Instruction for additional information on the ENR tables.

There is no system local oscillator used in Measurement Mode 1.0. The user controlled local oscillator is not used in Measurement Mode 1.5. In Measurement Modes 1.1 and 1.3, the system local oscillator can be swept over any range within a 2000 to 26500 MHz bandwidth. The system local oscillator is controlled by the existing system local oscillator programs, in the Noise Figure Meter. The system local oscillator programs can be modified to sweep the system local oscillator up to 99999 MHz. In Measurement Modes 1.6 and 1.8, the user controlled local oscillator can be swept over any range necessary, needed for a measurement. The user controlled local oscillator is controlled by the user and not by the Noise Figure Meter. The frequency that the user controlled local oscillator needs to be set to can be displayed using Special Function 3.2. In

Measurement Modes Summary

Measurement Mode	Type of Measurement	Measurement Frequencies	Frequency Conversion in DUT?	System LO Required?	User-Controlled LO Required?	IF into NF Meter (Modes 1.1-1.4) or IF into NF Test Set (Modes 1.6-1.9)	Sideband Selection ¹
1.0	RF Amplifier	10-1600 MHz 2047 opt 020	No	No	No	N/A ²	N/A ²
1.1	Microwave Amplifier	>1600 MHz 2047 opt 020	No	Yes-Variable frequency	No	Fixed IF into NF Meter set with Special Function 3.0.	Sideband selection is required only if NF Meter controls System LO.
1.2	Microwave Amplifier	>1600 MHz 2047 opt 020	No	Yes-Fixed frequency set with Special Function 3.1	No	Variable IF into NF Meter	Double sideband is not allowed. Sideband selection is required to calculate IF.
1.3	Mixer/ Receiver	IF=10-1600 MHz 2047 opt 020	Yes	Mixer-Yes, variable frequency; Receiver-No	No	Fixed IF into NF Meter set with Special Function 3.0.	Sideband selection is required only if NF Meter controls System LO.
1.4	Mixer/ Receiver	IF=10-1600 MHz 2047 opt 020	Yes	Mixer-Yes, fixed frequency set with Special Function 3.1; Receiver-No	No	Variable IF into NF Meter	Sideband selection is required to calculate measurement frequency.
1.5	RF or Microwave Amplifier	10-26500 MHz	No	Yes	No	N/A ²	N/A ²
1.6	Millimeter-Wave Amplifier	>26500 MHz and IF= 10 - 26500 MHz	No	Yes	Yes-Variable frequency	Fixed IF into NF Test Set set with Special Function 3.0.	No sideband selection is required unless Special Function 3.2 is used to find user LO frequency.
1.7	Millimeter-Wave Amplifier	>26500 MHz and IF > 10 MHz	No	Yes	Yes-Fixed frequency set with Special Function 3.1.	Variable IF into NF Test Set	Double sideband is not allowed. Sideband selection is required to calculate IF.
1.8	Mixer/ Receiver	IF= 10 - 26500 MHz	Yes	Yes	Mixer-Yes, variable frequency; Receiver-No	Fixed IF into NF Test Set set with Special Function 3.0.	No sideband selection is required unless Special Function 3.2 is used to find user LO frequency.
1.9	Mixer/ Receiver	IF>10 MHz	Yes	Yes	Mixer-Yes, fixed frequency set with Special Function 3.1; Receiver-No	Variable IF into NF Test Set	Sideband selection is required to calculate correct measurement signal or user LO frequency when Special Function 3.2 is used.

¹ Double sideband = Special Function 2.0.
Lower single sideband (measurement frequency < LO frequency) = Special Function 2.1.
Upper single sideband (measurement frequency > LO frequency) = Special Function 2.2.
Single sideband signal up conversion (IF = measurement frequency + LO frequency) = Special Function 2.3.
An external filter is required for single sideband measurements.

² N/A = Not Applicable

Measurement Modes (cont'd) (Special Function 1)

Signal Comparison (cont'd)

Measurement Modes 1.2 and 1.4, the fixed system local oscillator frequency can be set to any point within the 10 to 99999 MHz range. In Measurement Modes 1.7 and 1.9, the fixed user controlled local oscillator frequency can be set to any point, necessary. The limiting factors within each range are the frequency range of the local oscillator and the noise source.

There is no mixer used in Measurement Modes 1.0 and 1.5. Looking back into the mixer in Measurement Modes 1.1, 1.3, 1.6 and 1.8, the Noise Figure Meter passband translates into two sidebands. Each sideband is separated from the local oscillator frequency by a fixed IF (the receiving frequency of the Noise Figure Meter or Noise Figure Test Set). As the local oscillator sweeps, the sidebands move with it. The frequency can be increased or decreased within the allowable frequency range. In Measurement Modes 1.2, 1.4, 1.7 and 1.9, the local oscillator frequency is held fixed. As the variable IF sweeps, the sidebands move away from the system local oscillator frequency in opposite directions for an increasing IF sweep and toward the local oscillator frequency for a decreasing IF sweep. Examples of both a fixed IF and a variable local oscillator, and a variable IF and fixed local oscillator are shown in the Noise Figure Meter Measurement Passband figure.

The Noise Figure Meter's input frequency range is 10 to 1600 MHz (2047 MHz, opt 020). In Measurement Mode 1.0 a swept measurement can sweep the Noise Figure Meter's 4 MHz passband over the 10 to 1600 MHz (2047 MHz, opt 020) range. The Noise Figure Measurement System (Noise Figure Meter, Noise Figure Test Set and system local oscillator) has a frequency range of 10 to 26500 MHz. In Measurement Mode 1.5 a swept measurement can sweep the Noise Figure Measurement System's 4 MHz passband over the 10 to 26500 MHz range. In Modes 1.1, 1.3, 1.6 and 1.8, the IF is fixed and the local oscillator frequency is swept within the frequency ranges previously explained. In Modes 1.2, 1.4, (1.7 and 1.9), the local oscillator frequency is fixed and the IF is swept across the 10 to 1600 MHz; 2047 MHz, opt 020 (10 to 26500 MHz for Modes 1.7 and 1.9) range. In Modes 1.1, 1.3, 1.4, 1.6, 1.8 and 1.9, either upper, lower, sum or both sidebands can be accepted by the Noise Figure Meter (Noise Figure Measurement System). However, in Modes 1.2 and 1.7, a double sideband measurement cannot be made (the Noise Figure Meter will display error E34). In these modes, a double sideband measurement does not make sense since the IF sweeps and the sidebands get further and further apart. Suppose the IF is a 1000 MHz, in this condition the average between the two 4 MHz passbands, 2000 MHz apart, might easily be useless data.

Indications

The frequencies displayed in the left display and entered as measurement frequencies for various measurement conditions are shown in the following table. The display frequency depends upon the measurement mode used and the sideband selected (Special Function 2). In Measurement Mode 1.0 and 1.5, no external conversion is performed so the left display represents the measurement signal (F_{signal}). In Measurement Modes 1.1 through 1.4 and 1.6 through 1.9 conversion is performed, thus creating an external IF. The Noise Figure Meter (Noise Figure Measurement System) is tuned to this IF while the system (user controlled) local oscillator is tuned to F_{LO} .

For Measurement Modes 1.1, 1.3, 1.6 and 1.8:

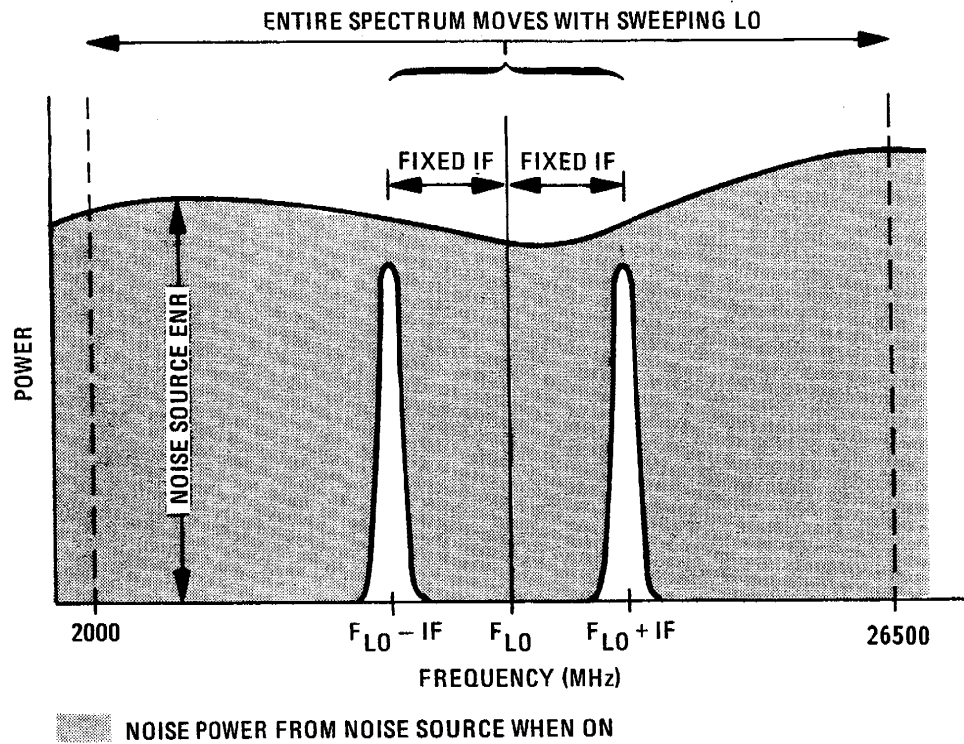

For Measurement Modes 1.2, 1.4, 1.7 and 1.9:

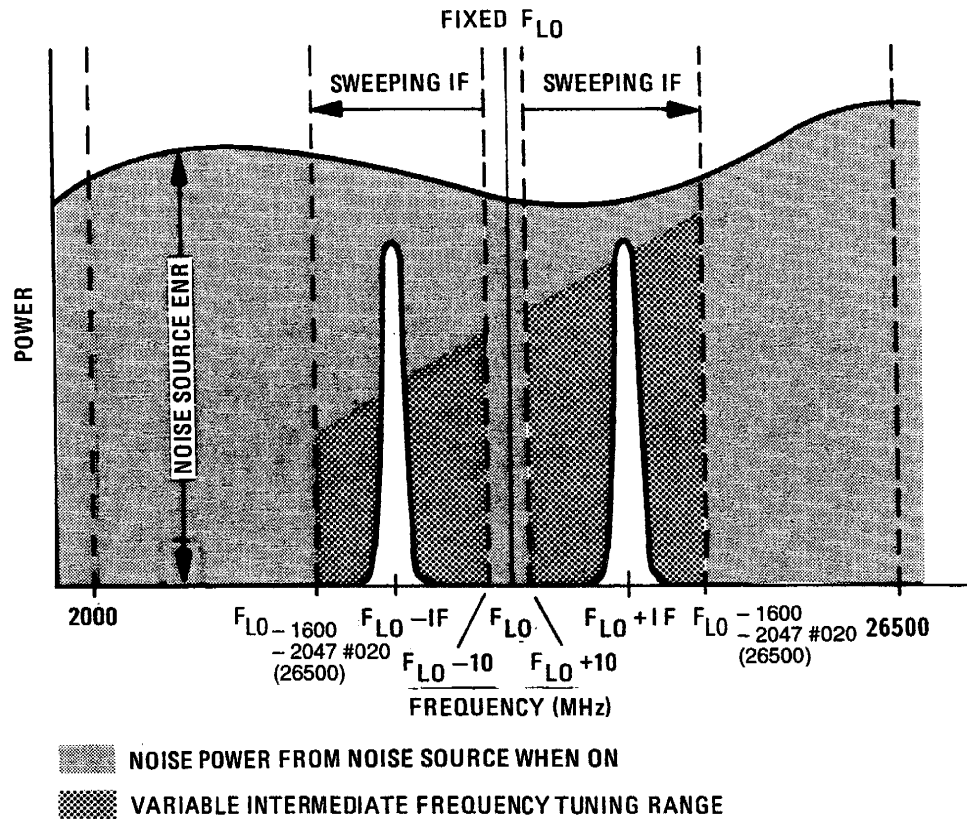

Figure 3-18. Noise Figure Meter Measurement Passband

Measurement Modes (cont'd) (Special Function 1)

Indications

Noise Figure Meter Left Display

Selected Sideband	Measurement Mode				
	1.0 and 1.5	1.1 and 1.6	1.2 and 1.7	1.3 and 1.8	1.4 and 1.9
Double Sideband (2.0SP)	F_{signal}	F_{LO}	not allowed	F_{LO}	IF
Lower Single Sideband (2.1SP)	F_{signal}	$F_{\text{LO}} - \text{IF}$	$F_{\text{LO}} - \text{IF}$	$F_{\text{LO}} - \text{IF}$	IF
Upper Single Sideband (2.2SP)	F_{signal}	$F_{\text{LO}} + \text{IF}$	$F_{\text{LO}} + \text{IF}$	$F_{\text{LO}} + \text{IF}$	IF
Sum (up conversion; 2.3SP)	F_{signal}	$\text{IF} - F_{\text{LO}}$	$\text{IF} - F_{\text{LO}}$	$\text{IF} - F_{\text{LO}}$	IF

Measurement Mode and Sideband Selection

Prior to making any measurement, the Measurement Mode and sideband operation that are best suited to that specific measurement must be chosen.

Each of the Detailed Operating Instructions for Measurement Modes 1.0 through 1.9 has valid examples of the type of measurements that are made in each mode.

Related Sections

- Calibrate
- ENR Table Entry
- Fixed IF or LO Frequency Selection
- Measurement Modes 1.0 through 1.9
- Sideband Selection

Measurement Mode 1.0

(Special Function 1.0)

Description

Measurement Mode 1.0 is for DUTs with no frequency conversion and a maximum frequency less than 1600 MHz (2047 MHz, opt 020). Measurements are single sideband. No external mixer or LO is required. The typical DUT is an amplifier or a transistor. All the Measurement Modes can be set up to use many of the other capabilities of the Noise Figure Meter. For example, each mode can make either UNCORRECTED NOISE FIGURE or CORRECTED NOISE FIGURE AND GAIN measurements, plus the measurement results for each mode can be displayed on an oscilloscope and output to a recorder or plotter.

Procedure

There are many possible measurement procedures. However, the following general procedure applies to all cases:

NOTE

High measurement system noise figure leads to high measurement uncertainty, when measuring low gain devices. A low noise preamplifier, between the device under test and the measurement system, can lower system noise figure and therefore reduce the measurement uncertainty. For more information on determining if a preamplifier is needed and selection of the preamplifier, refer to Application Note 57-2.

- a. Set frequency parameters.
- b. Calibrate in Mode 1.0 (this is only required for a CORRECTED NOISE FIGURE AND GAIN measurement).
- c. Insert DUT and measure.

Example

To make a swept CORRECTED NOISE FIGURE AND GAIN measurement in the 100 to 150 MHz range in 1 MHz steps:

- a. Press PRESET (or send HP-IB code PR) to establish initial conditions. This sets the Noise Figure Meter to Measurement Mode 1.0.
- b. Set the frequency parameters for both the calibration and measurement.
- c. Enter actual ENR for the Noise Source, if this has not previously been done.

Measurement Mode 1.0 (cont'd) (Special Function 1.0)

Example
(cont'd)

LOCAL (keystrokes)	<table style="margin: auto;"> <tr> <td style="text-align: center;">Function</td> <td style="text-align: center;">Data</td> <td style="text-align: center;">Function</td> </tr> <tr> <td style="text-align: center;">START FREQ</td> <td style="text-align: center;">1 0 0</td> <td style="text-align: center;">ENTER</td> </tr> <tr> <td style="text-align: center;">STOP FREQ</td> <td style="text-align: center;">1 5 0</td> <td style="text-align: center;">ENTER</td> </tr> <tr> <td style="text-align: center;">STEP SIZE</td> <td style="text-align: center;">1</td> <td style="text-align: center;">ENTER</td> </tr> </table>	Function	Data	Function	START FREQ	1 0 0	ENTER	STOP FREQ	1 5 0	ENTER	STEP SIZE	1	ENTER
Function	Data	Function											
START FREQ	1 0 0	ENTER											
STOP FREQ	1 5 0	ENTER											
STEP SIZE	1	ENTER											
HP-IB (program codes)	<p style="text-align: center;">FA100MZFB150MZSS1MZ</p> <table style="margin: auto;"> <tr> <td style="text-align: center;">Code</td> <td style="text-align: center;">Function</td> </tr> <tr> <td style="text-align: center;">Data</td> <td style="text-align: center;">Data</td> </tr> <tr> <td style="text-align: center;">Function</td> <td style="text-align: center;">Code</td> </tr> <tr> <td style="text-align: center;">Code</td> <td style="text-align: center;">Function</td> </tr> </table>	Code	Function	Data	Data	Function	Code	Code	Function				
Code	Function												
Data	Data												
Function	Code												
Code	Function												

d. To calibrate the Noise Figure Meter, set up the equipment as shown below.

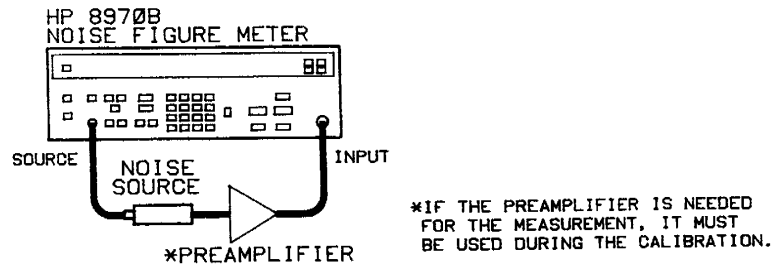

Figure 3-19. Measurement Mode 1.0 Calibration Setup

e. Calibrate the equipment in Measurement Mode 1.0 by pressing CALIBRATE twice (or send HP-IB code CA). The Noise Figure Meter was set to Measurement Mode 1.0 when PRESET was pressed.

f. To make the measurement, set up the equipment as shown below.

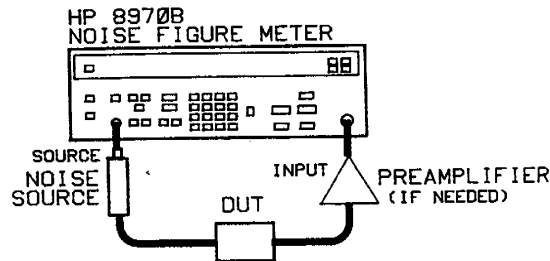

Figure 3-20. Mode 1.0 Measurement Setup

g. Press CORRECTED NOISE FIGURE AND GAIN (or send HP-IB code M2).

h. Press SINGLE (or send HP-IB code W2). The Noise Figure Meter will sweep from 100 MHz to 150 MHz in 1 MHz steps and halt.

Measurement Mode 1.0 (cont'd)

(Special Function 1.0)

**Program
Codes**The icon consists of the text "HP-IB" inside a dark, rounded rectangular box with a white border.

The HP-IB code for Measurement Mode 1.0 is E0 (or 1.0SP).

Indications

The left display shows each frequency at which a measurement is made. The INSERTION GAIN display shows the gain of the DUT at the displayed frequency. The NOISE FIGURE display shows the noise figure of the DUT at the displayed frequency.

Comments

Measurement Mode 1.0 is often referred to as an RF measurement. The other nine Measurement Modes are often referred to as microwave measurements.

**Related
Sections**

Calibrate
Measurement Modes
Special Functions

Measurement Mode 1.1

(Special Function 1.1)

Description

Measurement Mode 1.1 is for DUTs with no frequency conversion, but whose maximum frequency is greater than 1600 MHz (2047 MHz, opt 020). The Measurement is double sideband at a fixed low frequency IF, or a single sideband at a high IF frequency using appropriate filters, and is performed with a mixer and an external system LO controlled by the Noise Figure Meter. The typical DUT is an amplifier or a transistor. Although the input frequency to the Noise Figure Meter is 10 MHz to 1600 MHz (2047 MHz, opt 020), the Noise Figure Meter uses the excess noise ratio, ENR, of the noise source at the DUT input frequency. All the Measurement Modes can be set up to use many of the other capabilities of the Noise Figure Meter. For example, each mode can make either UNCORRECTED NOISE FIGURE or CORRECTED NOISE FIGURE AND GAIN measurements, plus the measurement results for each mode can be displayed on an oscilloscope and output to a recorder or plotter.

Requirements

The following minimum requirements are necessary for the Noise Figure Meter to act as a controller in Measurement Mode 1.1:

- a. Connect the system local oscillator to the Noise Figure Meter's SYSTEM INTERFACE BUS connector with an HP-IB cable.
- b. Special Function 48.0 active (Noise Figure Meter is the controller on System Interface Bus; Special Function 48.0 is the default setting, after using Special Function 0.9.).
- c. Special Function 46.0 active (Enable system local oscillator on the System Interface Bus; Special Function 46.0 is the default setting, after using Special Function 0.9.).
- d. The address of the system LO must match the system LO address that is stored in the Noise Figure Meter. Use Special Function 40.1 (system LO address) to display and change this address if necessary. The default address is 19, after using Special Function 0.9.
- e. The correct system local oscillator program must be active if the Noise Figure Meter is going to control the system local oscillator. The system local oscillator programs are listed below:
 - HP 8350B Sweep Oscillator; Special Function 41.0
 - HP 8671B/8672A Synthesized Signal Generators; Special Function 41.2
 - HP 8673B/C/G Synthesized Signal Generator; Special Function 41.3
 - HP 8340B/8341B Sweep Oscillator; Special Function 41.4
 - custom local oscillator; Special Function 41.5

The custom local oscillator program will support local oscillators that may require a maximum of twenty-two characters for the frequency prefix and suffix and/or the output power prefix and suffix. The prefix and suffix define the command sequence that will set the frequency or output power.

Measurement Mode 1.1 (cont'd)

(Special Function 1.1)

Requirements (cont'd) Use Special Function 42 to define a new program for other system local oscillators.

Procedure There are many possible measurement procedures. However, the following general procedure applies to all cases:

NOTE

High measurement system noise figure leads to high measurement uncertainty, when measuring low gain devices. A low noise preamplifier, between the device under test and the measurement system, can lower system noise figure and therefore reduce the measurement uncertainty. For more information on determining if a preamplifier is needed and selection of the preamplifier, refer to Application Note 57-2.

- a. Verify that the minimum requirements specified under Requirements are satisfied.
- b. Press 1 . 1 SPECIAL FUNCTION to set the Noise Figure Meter to Measurement Mode 1.1.
- c. Set frequency parameters (including the fixed IF, Special Function 3.0).
- d. Calibrate in Mode 1.1. If a preamplifier will be used in the measurement, the preamplifier must be used during the calibration.
- e. Insert DUT and measure.

Example To make a swept double sideband CORRECTED NOISE FIGURE AND GAIN measurement in the 6 to 12 GHz range in 200 MHz steps with a fixed IF of 70 MHz:

NOTE

This example assumes that the Noise Figure Meter is acting as a controller on the System Interface Bus and the minimum requirements specified under Requirements are satisfied. Refer to Comments for a brief description of using an external controller when in Measurement Mode 1.1.

- a. Press PRESET to establish initial conditions.

NOTE

Measurement Mode 1.1 must be activated prior to entering the frequency parameters to avoid error E35 (entered value is out of range).

- b. Press 1 . 1 SPECIAL FUNCTION to activate Measurement Mode 1.1.
- c. Set the frequency parameters for both the calibration and measurement.
- d. Enter actual ENR for the Noise Source, if this has not previously been done.

Measurement Mode 1.1 (cont'd)

(Special Function 1.1)

Example (cont'd)

- h. Press CORRECTED NOISE FIGURE AND GAIN.
- i. Press SINGLE. The Noise Figure Meter will sweep the system LO from 6 GHz to 12 GHz in 200 MHz steps and halt.

Program Codes

HP-IB

The HP-IB code for Measurement Mode 1.1 is E1 (or 1.1SP). Refer to Comments for additional information on using HP-IB program codes in Measurement Mode 1.1.

Indications

The left display shows each frequency at which a measurement is made and the EXT MIX annunciator lights. The INSERTION GAIN display shows the gain of the DUT at the displayed frequency. The NOISE FIGURE display shows the noise figure of the DUT at the displayed frequency.

Comments

An external controller can be used in place of the Noise Figure Meter to control the system LO and the Noise Figure Meter in Measurement Mode 1.1. The following general conditions must be observed when using an external controller:

- a. Connect the system local oscillator and the external controller to the HP-IB connector on the Noise Figure Meter.
- b. HP-IB code H1 must be active.
- c. Special Function 46.1 must be active.
- d. Special Function 4.0 (normal talker and listener) must be active. Note that there is no HP-IB code for this special function.
- e. Special Function 30.1 (trigger hold) must be active (HP-IB code is T1).
- f. The correct measurement parameters (for example, Measurement Mode, frequencies, etc.) must be established. Refer to Table 3-9, Special Function to HP-IB Code Summary, and Table 3-10, Front Panel Keys to HP-IB Code Summary, for applicable HP-IB codes.
- g. Perform a triggered calibration with the DUT out of the measurement system (refer to the Calibrate Detailed Operating Instruction).
- h. Set the Noise Figure Meter's calibrate function on (HP-IB code is CA).
- i. Set the system LO to the appropriate frequency. Refer to the LO's operating manual for the required HP-IB codes. Allow sufficient settling time for the output of the LO to stabilize.
- j. Trigger a measurement using the HP-IB code T2. Do not use the alternate HP-IB code 30.2SP for it will be ignored.
- k. A method must be determined when to step to a new frequency and read the noise figure results. This read operation cannot be completed until the new data is ready. It is possible to write an SRQ interrupt routine on the Data Ready status bit. Refer to Enabling the Service Request Condition, paragraph 3-30.

Measurement Mode 1.1 (cont'd)

(Special Function 1.1)

Comments (cont'd)

l. Continue to loop through steps i, j and k. A method for determining when the calibration is completed must be programmed into the external controller. One method is to compare the frequency that is sent to the system LO with the stop frequency programmed into the Noise Figure Meter and terminate the program after the third measurement in which they are equal. It is also possible to write an SRQ interrupt routine on the Calibration Complete SRQ. Refer to Enabling the Service Request Condition, paragraph 3-30.

m. Insert the DUT into the measurement system.

n. Set the Noise Figure Meter's SINGLE sweep on (HP-IB code is W2) or AUTO sweep on (HP-IB code is W1).

o. Set the system LO to the appropriate frequency. Refer to the LO's operating manual for the required HP-IB codes. Allow sufficient time for the output of the LO to stabilize.

p. Trigger a measurement using the HP-IB code T2. Do not use the alternate HP-IB code 30.2SP for Special Function 30.2 as it will reset the sweep.

q. A method must be determined when to step to a new frequency and read the noise figure results. This read operation cannot be completed until the new data is ready. It is possible to write an SRQ interrupt routine on the Data Ready SRQ. Refer to Enabling the Service Request Condition, paragraph 3-30.

r. Continue to loop through steps o, p, and q. A method for determining when the measurements are complete must be programmed into the external controller. One method is to compare the frequency that was read from the Noise Figure Meter with the stop frequency programmed into the Noise Figure Meter and terminate the program after the measurement in which they are equal.

External filtering is necessary for single sideband measurements using Special Functions 2.1 through 2.3.

Related Sections

Calibrate
Controller Capability of the Noise Figure Meter
Fixed IF or LO Frequency Selection
Measurement Modes
Sideband Selection
Special Functions
Trigger Selection

Measurement Mode 1.2

(Special Function 1.2)

Description

Measurement Mode 1.2 is for DUTs with no frequency conversion, whose bandwidth is less than 1590 MHz (2037 MHz, opt 020) but whose maximum frequency is greater than 1600 MHz (2047 MHz, opt 020). The measurement is single sideband and requires a filter (to eliminate the undesired sideband), an external mixer and a fixed LO. The Noise Figure Meter is tuned over a variable IF ranging from 10 to 1600 MHz (2047 MHz, opt 020). The typical DUT is an amplifier with a bandwidth less than 1590 MHz (2037 MHz, opt 020). Although the input frequency to the Noise Figure Meter ranges from 10 to 1600 MHz (2047 MHz, opt 020), the Noise Figure Meter uses the excess noise ratio, ENR, of the noise source at the DUT input frequency. All the Measurement Modes can be set up to use many of the other capabilities of the Noise Figure Meter. For example, each mode can make either UNCORRECTED NOISE FIGURE or CORRECTED NOISE FIGURE AND GAIN measurements, plus the measurement results for each mode can be displayed on an oscilloscope and output to a recorder or plotter.

Requirements

The following minimum requirements are necessary for the Noise Figure Meter to act as a controller in Measurement Mode 1.2:

- a. The system local oscillator is connected to the Noise Figure Meter's SYSTEM INTERFACE BUS connector with an HP-IB cable.
- b. Special Function 48.0 active (Noise Figure Meter is controller on System Interface Bus; Special Function 48.0 is the default setting, after using Special Function 0.9.).
- c. Special Function 46.0 active (Enable local oscillator on System Interface Bus; Special Function 46.0 is the default setting, after using Special Function 0.9.).
- d. The address of the system local oscillator must match the system local oscillator address that is stored in the Noise Figure Meter. Use Special Function 40.1 (system local oscillator address) to display and change this address if necessary. The default address is 19, after using Special Function 0.9.
- e. The correct system local oscillator program must be active if the Noise Figure Meter is going to control the system local oscillator. The system local oscillator programs are listed below:
 - HP 8350B Sweep Oscillator; Special Function 41.0
 - HP 8671B/8672A Synthesized Signal Generators; Special Function 41.2
 - HP 8673B/C/G Synthesized Signal Generator; Special Function 41.3
 - HP 8340B/8341B Sweep Oscillator; Special Function 41.4
 - custom local oscillator; Special Function 41.5

Measurement Mode 1.2 (cont'd)

(Special Function 1.2)

Requirements (cont'd)

The custom local oscillator program will support local oscillators that may require a maximum of twenty-two characters for the frequency prefix and suffix and/or the output power prefix and suffix. The prefix and suffix define the command sequence that will set the frequency or output power.

Use Special Function 42 to define a new program for other system local oscillators.

Procedure

There are many possible measurement procedures. However, the following general procedure applies to all cases:

NOTE

High measurement system noise figure leads to high measurement uncertainty, when measuring low gain devices. A low noise preamplifier, between the device under test and the measurement system, can lower system noise figure and therefore reduce the measurement uncertainty. For more information on determining if a preamplifier is needed and selection of the preamplifier, refer to Application Note 57-2.

- a. Select single sideband offset (use either Special Function 2.1, 2.2 or 2.3).
- b. Press 1 . 2 SPECIAL FUNCTION to set the Noise Figure Meter to Measurement Mode 1.2.
- c. Set frequency parameters (including the fixed frequency for the system LO, Special Function 3.1).
- d. Calibrate in Mode 1.2 (this is only required for a CORRECTED NOISE FIGURE AND GAIN measurement). External filtering is required during both the calibration and the measurement. If a preamplifier will be used during the measurement, the preamplifier must be used during the calibration.
- e. Insert DUT and measure.

NOTE

The following example assumes that the Noise Figure Meter is the controller, on the System Interface Bus. For information on using an external controller, refer to the Comments section at the end of this instruction.

Example

To make a swept CORRECTED NOISE FIGURE AND GAIN measurement of a wide-band amplifier in the 3.5 to 4.5 GHz range using 20 MHz steps and a fixed system LO of 5 GHz:

- a. Press PRESET (or send HP-IB code PR) to establish initial conditions.
- b. Press 2 . 1 SPECIAL FUNCTION (or send HP-IB code B1) to select a lower sideband measurement.

Measurement Mode 1.2 (cont'd)

(Special Function 1.2)

Example (cont'd)

NOTE

Measurement Mode 1.2 must be activated prior to entering the frequency parameters to avoid error E35 (entered value is out of range).

c. Press 1 . 2 SPECIAL FUNCTION (or send HP-IB code E2) to activate Mode 1.2. Note that error E33 (IF will be out of range) is displayed. This error is cleared when the correct frequency parameters are entered in step d.

d. Set the frequency parameters for both the calibration and measurement.

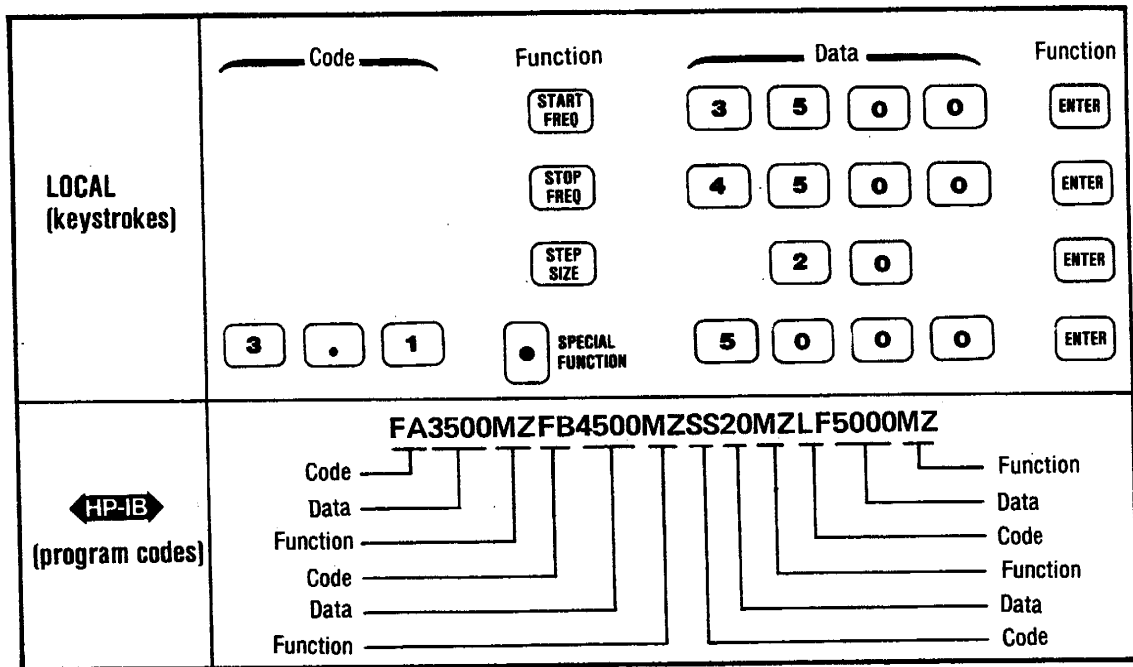

e. To calibrate the Noise Figure Meter, set up the equipment as shown below.

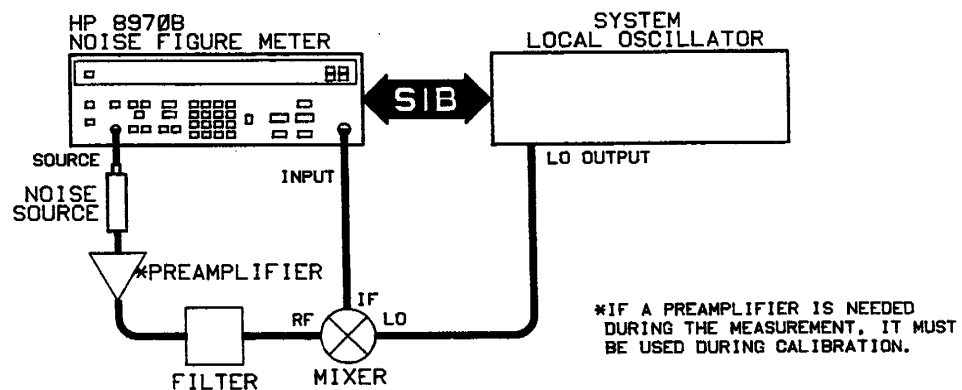

Figure 3-23. Measurement Mode 1.2 Calibration Setup

f. Calibrate the equipment in Measurement Mode 1.2 by pressing CALIBRATE twice (or sending HP-IB code CA).

Measurement Mode 1.2 (cont'd) (Special Function 1.2)

**Example
(cont'd)**

g. To make the measurement, set up the equipment as shown below.

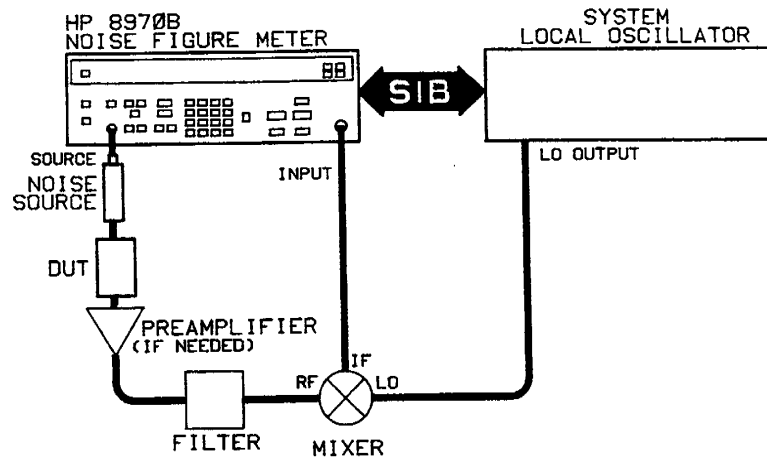

Figure 3-24. Measurement Mode 1.2 Setup

h. Press CORRECTED NOISE FIGURE AND GAIN (or send HP-IB code M2).

i. Press SINGLE (or send HP-IB code W2). The Noise Figure Meter will sweep from 1500 to 500 MHz in 20 MHz steps but will display the microwave measurement frequency of 3500 to 4500 MHz. After the single sweep is completed, the instrument halts.

The HP-IB code for Measurement Mode 1.2 is E2 (or 1.2SP).

**Program
Codes**

◀ HP-IB ▶

Indications

The left display shows each frequency at which a measurement is made and the EXT MIX annunciator lights. The INSERTION GAIN display shows the gain of the DUT at the displayed frequency. The NOISE FIGURE display shows the noise figure of the DUT at the displayed frequency.

Comments

An external controller can be used to control the Noise Figure Meter and system local oscillator. The following general conditions must be observed when using an external controller:

- a. Connect the system local oscillator and the external controller to the HP-IB connector on the Noise Figure Meter.
- b. HP-IB code H1 must be active.
- c. Special Function 46.1 must be active.
- d. Special Function 4.0 (normal talker and listener) must be active. Note that there is no HP-IB code for this special function.
- e. Special Function 30.0 (free run) should be active (HP-IB code is T0).

Measurement Mode 1.2 (cont'd)

(Special Function 1.2)

Comments (cont'd)

f. The correct measurement parameters (for example, Measurement Mode, frequencies, etc.) must be established. Refer to Table 3-9, Special Function to HP-IB Code Summary and Table 3-10, Front Panel Keys to HP-IB Code Summary, for applicable HP-IB codes.

g. Set up for a calibration with the device under test (DUT) out of the measurement system (refer to the Calibrate Detailed Operating Instruction).

h. Set the system local oscillator to the desired frequency. Refer to the local oscillator's operating manual for the required HP-IB codes. Allow sufficient time for the output of the local oscillator to stabilize.

i. Send the command "RM 2EN RS CA." Wait for a serial poll to return a non-zero value, indicating calibration is complete.

j. Insert the DUT into the measurement system.

k. Special Function 30.1 (trigger hold) must be active (HP-IB code is T1).

l. Set the Noise Figure Meter's SINGLE sweep on (HP-IB code is W2) or AUTO sweep on (HP-IB code is W1).

m. Trigger a measurement using the HP-IB code T2. Do not use the alternate HP-IB code 30.2SP for Special Function 30.2 as it will reset the sweep.

n. A method must be determined when to step to a new frequency and read the noise figure results. This read operation cannot be completed until the new data is ready. It is possible to write an SRQ interrupt routine on the Data Ready SRQ. Refer to Enabling the Service Request Condition, paragraph 3-30.

o. Continue to loop through steps m and n. A method for determining when the measurements are complete must be programmed into the external controller. One method is to compare the frequency that was read from the Noise Figure Meter with the stop frequency programmed into the Noise Figure Meter and terminate the program after the measurement in which they are equal.

External filtering is necessary for single sideband measurements using Special Functions 2.1 through 2.3.

Related Sections

Calibrate
Controller Capability of the Noise Figure Meter
Fixed IF or LO Frequency Selection
Measurement Modes
Sideband Selection
Special Functions

Measurement Mode 1.3

(Special Function 1.3)

Description

Measurement mode 1.3 is for frequency converting DUTs with a fixed IF less than 2047 MHz, and a variable LO which may be controlled (if desired) by the Noise Figure Meter. A typical DUT is a mixer or receiver. Although the input frequency to the Noise Figure Meter ranges from 10 MHz to 2047 MHz, the Noise Figure Meter uses the excess noise ratio, ENR, of the noise source at the DUT input frequency. All the Measurement Modes can be set up to use many of the other capabilities of the Noise Figure Meter. For example, each mode can make either UNCORRECTED NOISE FIGURE or CORRECTED NOISE FIGURE AND GAIN measurements, plus the measurement results for each mode can be displayed on an oscilloscope and output to a recorder or plotter.

Requirements

The following minimum requirements are necessary for the Noise Figure Meter to act as a controller in Measurement Mode 1.3:

- a. The system local oscillator must be connected to the Noise Figure Meter's SYSTEM INTERFACE BUS connector with an HP-IB cable.
- b. Special Function 48.0 active (Noise Figure Meter is controller on System Interface Bus; Special Function 48.0 is the default setting, after using Special Function 0.9.).
- c. Special Function 46.0 active (Enable local oscillator on System Interface Bus; Special Function 46.0 is the default setting, after using Special Function 0.9.).
- d. The address of the system LO must match the system LO address that is stored in the Noise Figure Meter. Use Special Function 40.1 to display and change this address if necessary. The default address is 19, after using Special Function 0.9.
- e. The correct system local oscillator program must be active if the Noise Figure Meter is going to control the system local oscillator. The system local oscillator programs are listed below:
 - HP 8350B Sweep Oscillator; Special Function 41.0
 - HP 8671B/8672A Synthesized Signal Generators; Special Function 41.2
 - HP 8673B/C/G Synthesized Signal Generator; Special Function 41.3
 - HP 8340B/8341B Sweep Oscillator; Special Function 41.4
 - custom local oscillator; Special Function 41.5

The custom local oscillator program will support local oscillators that may require a maximum of twenty-two characters for the frequency prefix and suffix and/or the output power prefix and suffix. The prefix and suffix define the command sequence that will set the frequency or output power.

Use Special Function 42 to define a new program for other system local oscillators.

Measurement Mode 1.3 (cont'd)

(Special Function 1.3)

Procedure

There are many possible measurement procedures. However, the following general procedure applies to all cases:

NOTE

High measurement system noise figure leads to high measurement uncertainty, when measuring low gain devices. A low noise preamplifier, between the device under test and the measurement system, can lower system noise figure and therefore reduce the measurement uncertainty. For more information on determining if a preamplifier is needed and selection of the preamplifier, refer to Application Note 57-2.

- a. Verify that the minimum requirements specified under Requirements are satisfied.
- b. Press 1 . 3 SPECIAL FUNCTION to set the Noise Figure Meter to Measurement Mode 1.3.
- c. Set frequency parameters (including the fixed IF, Special Function 3.0).
- d. Calibrate in Mode 1.3. If a preamplifier will be used during the measurement, the preamplifier must be used during the calibration.
- e. Insert DUT and initiate sweep.

Example

To make a swept CORRECTED NOISE FIGURE AND GAIN measurement in the 3.0 to 4.5 GHz range in 20 MHz steps with a fixed IF of 70 MHz:

NOTE

This example assumes that the Noise Figure Meter is acting as a controller on the System Interface Bus and the minimum requirements specified under Requirements are satisfied. Refer to Comments for a brief description of using an external controller when in Measurement Mode 1.3.

- a. Press PRESET (or send HP-IB code PR) to establish initial conditions.

NOTE

Measurement Mode 1.3 must be activated prior to entering the frequency parameters to avoid error E35 (entered value is out of range).

- b. Press 1 . 3 SPECIAL FUNCTION to activate Measurement Mode 1.3.
- c. Set the frequency parameters for both the calibration and measurement.

Measurement Mode 1.3 (cont'd)

(Special Function 1.3)

Program Codes

HP-IB

The HP-IB code for Measurement Mode 1.3 is E3 (or 1.3SP). Refer to Comments for additional information on using HP-IB program codes in Measurement Mode 1.3.

Indications

The left display shows each frequency at which a measurement is made and the EXT MIX annunciator lights. The INSERTION GAIN display shows the gain of the DUT at the displayed frequency. The NOISE FIGURE display shows the noise figure of the DUT at the displayed frequency.

Comments

An external controller can be used in place of the Noise Figure Meter to control the system LO and the Noise Figure Meter in Measurement Mode 1.3. The following general conditions must be observed when using an external controller:

- a. The system local oscillator and the external controller must be connected to the HP-IB connector on the Noise Figure Meter.
- b. HP-IB code H1 must be active.
- c. Special Function 46.1 must be active.
- d. Special Function 4.0 (normal talker and listener) must be active. Note that there is no HP-IB code for this special function.
- e. Special Function 30.0 (free run) should be active (HP-IB code is T0).
- f. The correct measurement parameters (for example, Measurement Mode, frequencies, etc.) must be established. Refer to Table 3-9, Special Function to HP-IB Code Summary, and Table 3-10, Front Panel Keys to HP-IB Code Summary, for applicable HP-IB codes.
- g. Set up for a calibration with the DUT out of the measurement system (refer to the Calibrate Detailed Operating Instruction).
- h. Send the command "RM 2EN RS CA". Wait for a serial poll to return a non-zero value, indicating calibration is complete.
- i. Insert the DUT into the measurement system.
- j. Special Function 30.1 (trigger hold) must be active (HP-IB code is T1).
- k. Set the Noise Figure Meter's SINGLE sweep on (HP-IB code is W2) or AUTO sweep on (HP-IB code is W1).
- l. Set the system LO to the appropriate frequency. Refer to the LO's operating manual for the required HP-IB codes. Allow sufficient time for the output of the system LO to stabilize.
- m. Trigger a measurement using the HP-IB code T2. Do not use the alternate HP-IB code 30.2SP for Special Function 30.2 as it will reset the sweep.

Measurement Mode 1.3 (cont'd)

(Special Function 1.3)

Comments (cont'd)

n. A method must be determined when to step to a new frequency and read the noise figure results. This read operation cannot be completed until the new data is ready. It is possible to write an SRQ interrupt routine on the Data Ready SRQ. Refer to Enabling the Service Request Condition, paragraph 3-30.

o. Continue to loop through steps l, m, and n. A method for determining when the measurements are complete must be programmed into the external controller. One method is to compare the frequency that was read from the Noise Figure Meter with the stop frequency programmed into the Noise Figure Meter and terminate the program after the measurement in which they are equal.

External filtering is necessary for single sideband measurements, using Special Functions 2.1 through 2.3.

Related Sections

Calibrate
Controller Capability of the Noise Figure Meter
Fixed IF or LO Frequency Selection
HP-IB and System Interface Bus (SIB) Addresses
Sideband Selection
Special Functions
Trigger Selection

Measurement Mode 1.4

(Special Function 1.4)

Description

Measurement Mode 1.4 is for frequency converting DUTs with a broadband variable IF output ranging from 10 to 1600 MHz (2047 MHz, opt 020) and a fixed LO, which may be controlled (if desired) by the Noise Figure Meter. A typical DUT is a receiver or mixer with a full RF bandwidth IF or a satellite receiver block down converter. The measurement frequencies entered and displayed on the Noise Figure Meter correspond to the swept IF START, STOP and STEP frequencies. The Noise Figure Meter automatically calculates the DUTs input frequency and uses the excess noise ratio (ENR) at this frequency for noise calculations. All the measurement Modes can be set up to use many of the other capabilities of the Noise Figure Meter. For example, each mode can make either UNCORRECTED NOISE FIGURE or CORRECTED NOISE FIGURE AND GAIN measurements, plus the measurement results for each mode can be displayed on an oscilloscope and output to a recorder or plotter.

Requirements

The following minimum requirements are necessary for the Noise Figure Meter to act as a controller in Measurement Mode 1.4:

- a. The system local oscillator must be connected to the Noise Figure Meter's SYSTEM INTERFACE BUS connector with an HP-IB cable.
- b. Special Function 48.0 active (Noise Figure Meter is controller on System Interface Bus; Special Function 48.0 is the default setting, after using Special Function 0.9.).
- c. Special Function 46.0 active (Enable local oscillator on System Interface Bus; Special Function 46.0 is the default setting, after using Special Function 0.9.).
- d. The address of the system local oscillator must match the system local oscillator address that is stored in the Noise Figure Meter. Use Special Function 40.1 (system local oscillator address) to display and change this address if necessary. The default address is 19, after using Special Function 0.9.
- e. The correct system local oscillator program must be active if the Noise Figure Meter is going to control the system local oscillator. The system local oscillator programs are listed below:
 - HP 8350B Sweep Oscillator; Special Function 41.0
 - HP 8671B/8672A Synthesized Signal Generators; Special Function 41.2
 - HP 8673B/C/G Synthesized Signal Generator; Special Function 41.3
 - HP 8340B/8341B Sweep Oscillator; Special Function 41.4
 - custom local oscillator; Special Function 41.5

The custom local oscillator program will support local oscillators that may require a maximum of twenty-two characters for the frequency prefix and suffix and/or the output power prefix and suffix. The prefix and suffix define the command sequence that will set the frequency or output power.

Measurement Mode 1.4 (cont'd)

(Special Function 1.4)

Description (cont'd) Procedure

Use Special Function 42 to define a new program for other system local oscillators.

There are many possible measurement procedures. However, the following general procedure applies to all cases:

NOTE

High measurement system noise figure leads to high measurement uncertainty, when measuring low gain devices. A low noise preamplifier, between the device under test and the measurement system, can lower system noise figure and therefore reduce the measurement uncertainty. For more information on determining if a preamplifier is needed and selection of the preamplifier, refer to Application Note 57-2.

a. Set the frequency parameters. The frequency parameters include the frequency of the system LO or DUT LO (Special Function 3.1); and the sideband selection (Special Functions 2.0, 2.1 or 2.2 for double, lower or upper sideband). Note that the START, STOP and STEP frequencies refer to the IF frequencies. Special Function 3.1 and 2.1 or 2.2 must be used, even if the DUT's LO isn't on the SYSTEM INTERFACE BUS so the Noise Figure Meter will be able to correctly determine the DUT's input frequency and, therefore, choose the appropriate ENR. If the DUT has its own internal LO, then disable the LO on the SYSTEM INTERFACE BUS, (Special Function 46.1).

b. Press 1 . 4 SPECIAL FUNCTION to set the Noise Figure Meter to Measurement Mode 1.4.

c. Calibrate in Mode 1.4 (this is only required for a CORRECTED NOISE FIGURE AND GAIN measurement). If a preamplifier will be used during the measurement, the preamplifier must be used during the calibration.

d. Insert DUT and measure.

e. The left display shows the swept IF.

Example

NOTE

The following example assumes that the Noise Figure Meter is the controller, on the System Interface Bus. For information on using an external controller, refer to the Comments section at the end of this instruction.

To make a swept CORRECTED NOISE FIGURE AND GAIN measurement over an IF of 10 MHz to 1 GHz using 20 MHz steps with a fixed system LO frequency of 10 GHz:

a. Press PRESET (or send HP-IB code PR) to establish initial conditions.

b. Set the frequency parameters for both the calibration and measurement.

Measurement Mode 1.4 (cont'd) (Special Function 1.4)

Example
(cont'd)

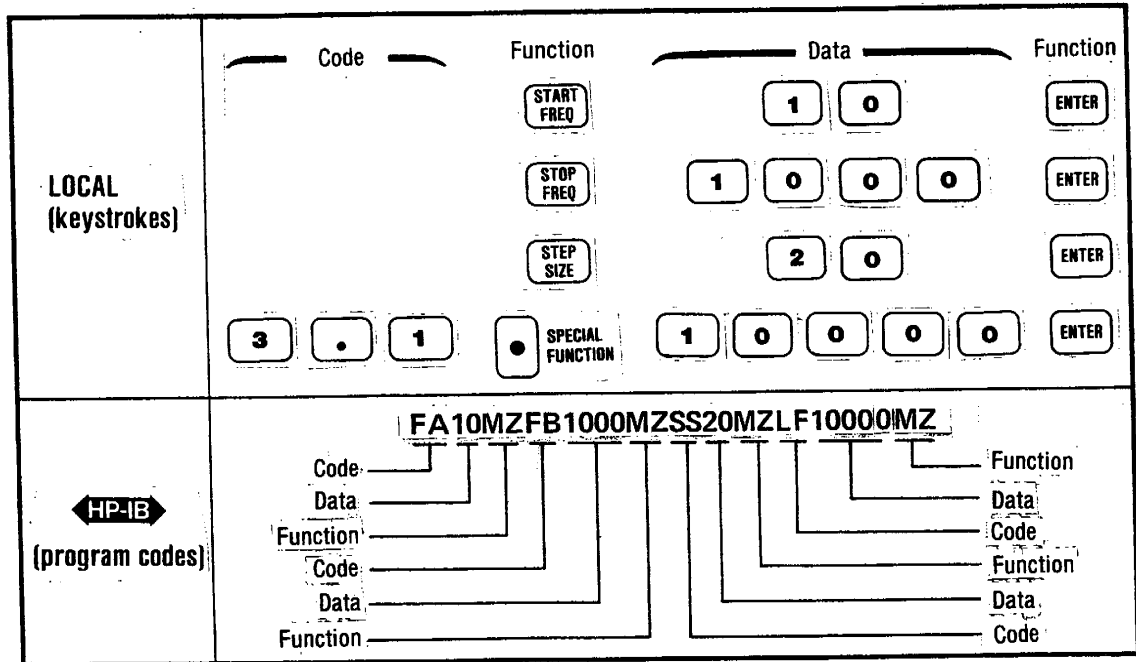

c. Press 1.4 SPECIAL FUNCTION (or send HP-IB code E4) to activate Measurement Mode 1.4.

d. To calibrate the Noise Figure Meter, set up the equipment as shown below.

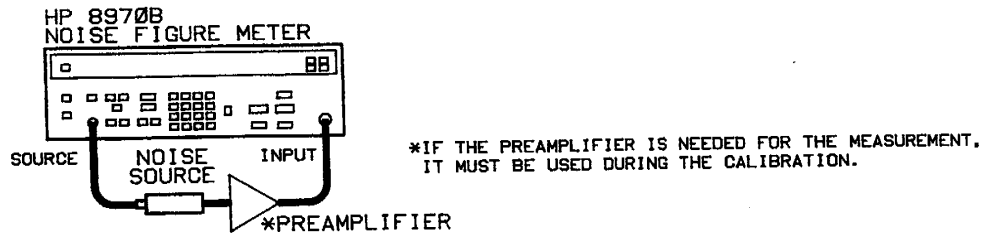

Figure 3-27. Measurement Mode 1.4 Calibration Setup

e. Calibrate the equipment in Measurement Mode 1.4 by pressing CALIBRATE twice (or sending HP-IB code CA).

f. To make the measurement, set up the equipment as shown below.

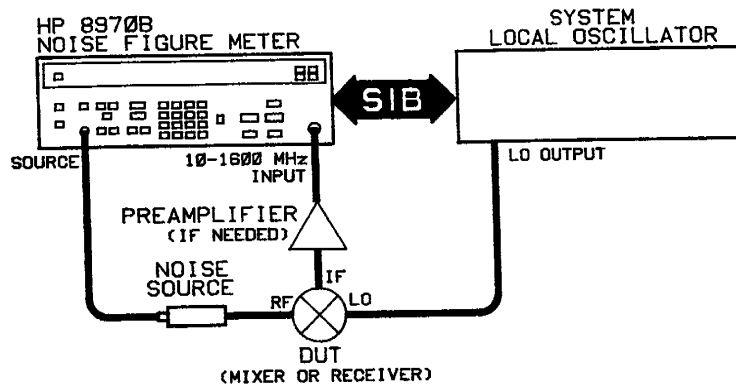

Figure 3-28. Measurement Mode 1.4 Setup

Measurement Mode 1.4 (cont'd)

(Special Function 1.4)

Example (cont'd)

g. Press CORRECTED NOISE FIGURE AND GAIN (or send HP-IB code M2).

h. Press SINGLE (or send HP-IB code W2). The Noise Figure Meter will sweep from 10 to 1000 MHz in 20 MHz steps. After the single sweep is completed, the instrument halts.

Program Codes

HP-IB

The HP-IB code for Measurement Mode 1.4 is E4 (or 1.4SP).

Indications

The left display shows each IF frequency at which a measurement is made and the EXT MIX annunciator lights. The INSERTION GAIN display shows the gain of the DUT at the displayed frequency. The NOISE FIGURE display shows the noise figure of the DUT at the displayed frequency.

Comments

An external controller can be used to control the Noise Figure Meter and system local oscillator. The following general conditions must be observed when using an external controller:

- a. The system local oscillator and the external controller must be connected to the HP-IB connector on the Noise Figure Meter.
- b. HP-IB code H1 must be active.
- c. Special Function 46.1 must be active.
- d. Special Function 4.0 (normal talker and listener) must be active. Note that there is no HP-IB code for this special function.
- e. Special Function 30.0 (free run) should be active (HP-IB code is T0).
- f. The correct measurement parameters (for example, Measurement Mode, frequencies, etc.) must be established. Refer to Table 3-9, Special Function to HP-IB Code Summary and Table 3-10, Front Panel Keys to HP-IB Code Summary, for applicable HP-IB codes.
- g. Set up for a calibration with the device under test (DUT) out of the measurement system (refer to the Calibrate Detailed Operating Instruction).
- h. Send the command "RM 2EN RS CA." Wait for a serial poll to return a non-zero value, indicating calibration is complete.
- i. Insert the DUT into the measurement system.
- j. Special Function 30.1 (trigger hold) must be active (HP-IB code T1).
- k. Set the Noise Figure Meter's SINGLE sweep on (HP-IB code is W2) or AUTO sweep on (HP-IB code is W1).

Measurement Mode 1.4 (cont'd)

(Special Function 1.4)

Comments (cont'd)

l. Set the system local oscillator to the desired frequency. Refer to the local oscillator's operating manual for the required HP-IB codes. Allow sufficient time for the output of the system local oscillator to stabilize.

m. Trigger a measurement using the HP-IB code T2. Do not use the alternate HP-IB code 30.2SP for Special Function 30.2 as it will reset the sweep.

n. A method must be determined when to step to a new frequency and read the noise figure results. This read operation cannot be completed until the new data is ready. It is possible to write an SRQ interrupt routine on the Data Ready SRQ. Refer to Enabling the Service Request Condition, paragraph 3-30.

o. Continue to loop through steps m and n. A method for determining when the measurements are complete must be programmed into the external controller. One method is to compare the frequency that was read from the Noise Figure Meter with the stop frequency programmed into the Noise Figure Meter and terminate the program after the measurement in which they are equal.

External filtering is necessary for single sideband measurements, using Special Functions 2.1 through 2.3.

Related Sections

Calibrate
Controller Capability of the Noise Figure Meter
Fixed IF or LO Frequency Selection
Sideband Selection
Special Functions

Measurement Mode 1.5

(Special Function 1.5)

Description

Measurement mode 1.5 is for DUTs with no frequency conversion that operate at frequencies from 10 MHz to 26.5 GHz. The HP 8971C and its LO are capable of performing both double and single (default) sideband down conversions into the frequency range of the HP 8970B Option 020. The typical DUT is an amplifier or a transistor. All the Measurement Modes can be set up to use many of the other capabilities of the Noise Figure Meter. For example, each mode can make either **UNCORRECTED NOISE FIGURE** or **CORRECTED NOISE FIGURE AND GAIN** measurements, plus the measurement results for each mode can be displayed on an oscilloscope and output to a recorder or plotter.

NOTE

The HP 8971B/C Noise Figure Test Set and the system local oscillator are required when making a measurement using Measurement Mode 1.5.

Requirements

The following minimum requirements are necessary for the Noise Figure Measurement System (Noise Figure Meter, Noise Figure Test Set and system local oscillator) to operate in Measurement Mode 1.5.

- a. The system local oscillator and the Noise Figure Test Set must be connected to the Noise Figure Meter's SYSTEM INTERFACE BUS connector with an HP-IB cable.
- b. Special Function 48.0 must be active (Noise Figure Meter is System controller on System Interface Bus; Special Function 48.0 is the default setting, after using Special Function 0.9).
- c. Special Function 45.0 must be active (Noise Figure Test Set enabled in measurement modes 1.5 through 1.9; Special Function 45.0 is the default setting, after using Special Function 0.9.) or Special Function 45.1 (Noise Figure Test Set enabled always) must be active.
- d. The address of the Noise Figure Test Set must match the Noise Figure Test Set address that is stored in the Noise Figure Meter. Use Special Function 40.2 (Noise Figure Test Set System Interface Bus address) to display and change this address if necessary. The default address for the Noise Figure Test Set is 10, after using Special Function 0.9.
- e. Special Function 46.0 must be active (Enable system local oscillator on System Interface Bus; Special Function 46.0 is the default setting, after using Special Function 0.9.)
- f. The address of the system local oscillator must match the address of the system local oscillator stored in the Noise Figure Meter. Use Special Function 40.1 (system local oscillator System Interface Bus address) to display and change this address if necessary. The default address is 19, after using Special Function 0.9.
- g. The correct system local oscillator program must be active if the Noise Figure Meter is going to control the system local oscillator. The system local oscillator programs are listed below:

Measurement Mode 1.5 (cont'd) (Special Function 1.5)

Requirements (cont'd)

- HP 8671B/8672A Synthesized Signal Generators; Special Function 41.2
- HP 8673B/C/G (Standard) Synthesized Signal Generator; Special Function 41.3
- HP 8340B/8341B Sweep Oscillator; Special Function 41.4
- Custom local oscillator; Special Function 41.5

The custom local oscillator program will support local oscillators that may require a maximum of twenty-two characters for the frequency prefix and suffix and/or the output power prefix and suffix. The prefix and suffix define the command sequence that will set the frequency or output power.

Use Special Function 42 to define a new program for other system local oscillators.

Procedure

There are many possible measurement procedures. However, the following general procedure applies to all cases:

NOTE

High measurement system noise figure leads to high measurement uncertainty, when measuring low gain devices. A low noise preamplifier, between the device under test and the measurement system, can lower system noise figure and therefore reduce the measurement uncertainty. For more information on determining if a preamplifier is needed and selection of the preamplifier, refer to Application Note 57-2.

- a. Verify that the minimum requirements specified under Requirements are satisfied.
- b. Press PRESET.
- c. Press 1.5 SPECIAL FUNCTION to set the Noise Figure Meter to Measurement Mode 1.5.
- d. Set frequency parameters.
- e. Select sideband operation desired (Special Function 17).
- f. Select appropriate smoothing (Special Function 13).
- g. Perform a Noise Figure Test Set Fine Tuning Calibration. Refer to the Noise Figure Test Set YIG Filter Calibration Detailed Operating Instruction.

Measurement Mode 1.5 (cont'd) (Special Function 1.5)

Procedure (cont'd)

h. Calibrate in Mode 1.5 (this is only required for a CORRECTED NOISE FIGURE AND GAIN measurement). If a preamplifier is required for the measurement, the preamplifier must be used in the calibration.

i. Insert device under test (DUT) and measure.

Example

To make a swept CORRECTED NOISE FIGURE AND GAIN single sideband measurement in the 3000 to 4000 MHz range in 10 MHz steps:

a. Press PRESET to establish initial conditions. Single sideband (Special Function 17.0) is active when PRESET is pressed.

b. Press 1.5 SPECIAL FUNCTION to set the Noise Figure Measurement System to Measurement Mode 1.5.

c. Set the frequency parameters for both the calibration and measurement.

d. Enter actual ENR for the Noise Source, if this has not previously been done.

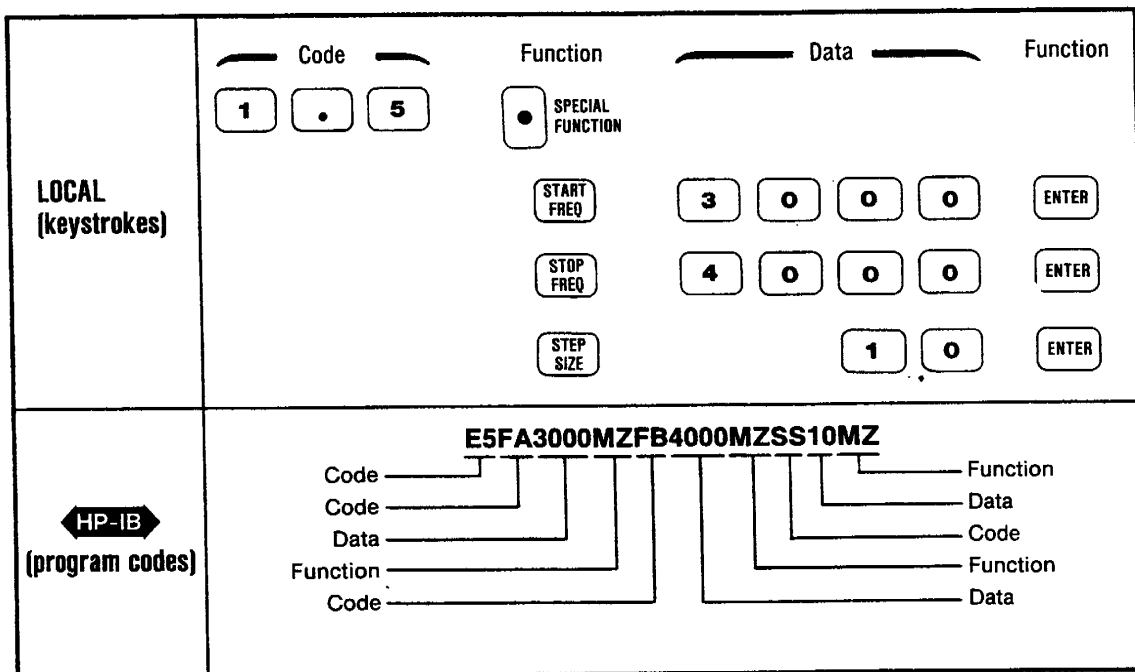

e. To calibrate and perform a Noise Figure Test Set Fine Tuning Calibration, set up the equipment as shown below.

Measurement Mode 1.5 (cont'd) (Special Function 1.5)

**Example
(cont'd)**

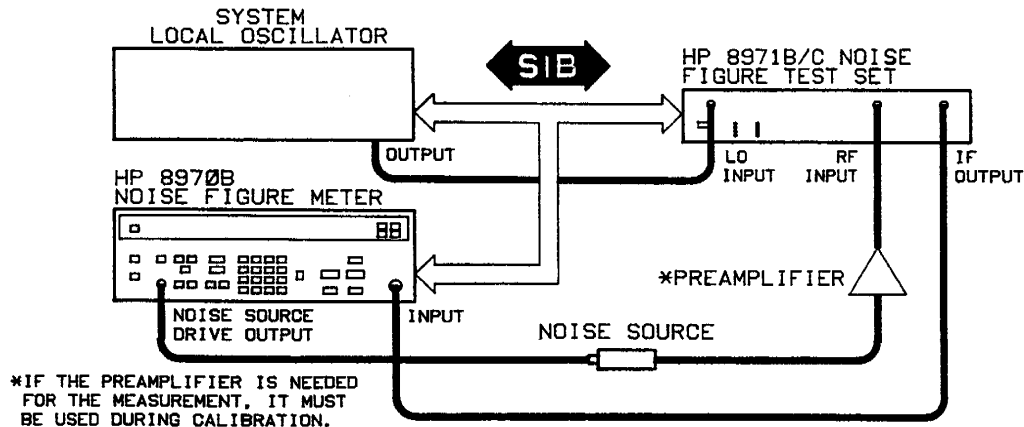

Figure 3-29. Measurement Mode 1.5 Calibration Setup

f. Calibrate and fine tune in Measurement Mode 1.5 by pressing CALIBRATE twice (or send HP-IB code CA). PRESET enabled a fine tune (Special Function 36.0) to be done each time a calibration is done.

g. To make the measurement, set up the equipment as shown below.

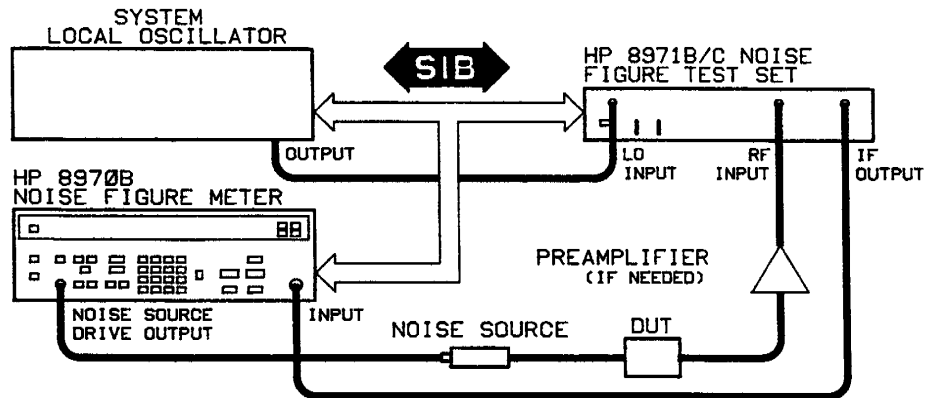

Figure 3-30. Measurement Mode 1.5 Setup

NOTE

For the Noise Figure Measurement System specifications to be valid, the measurement must use the same START FREQ, STOP FREQ and STEP SIZE that was used for calibration. None of the calibrated points can be skipped. Also, the measurement must be done in the same direction as the calibration, for example, from start frequency to stop frequency.

h. Press CORRECTED NOISE FIGURE AND GAIN (or send HP-IB code M2).

i. Press SINGLE (or send HP-IB code W2). The Noise Figure Measurement System will sweep from 3000 MHz to 4000 MHz in 10 MHz steps and halt.

Measurement Mode 1.5 (cont'd)

(Special Function 1.5)

Program Codes



The HP-IB code for Measurement Mode 1.5 is E5 (or 1.5SP).

Indications

The left display shows each frequency at which a measurement is made. The INSERTION GAIN display shows the gain of the DUT at the displayed frequency. The NOISE FIGURE display shows the noise figure of the DUT at the displayed frequency.

Related Sections

Calibrate
Noise Figure Test Set YIG Filter Calibration
Measurement Modes
Sideband Selection
Special Functions

Measurement Mode 1.6 (Special Function 1.6)

Description

Measurement Mode 1.6 is for DUTs with no frequency conversion that operate at frequencies greater than 26.5 GHz. The measurement system may be single or double sided. The measuring system uses double conversion with a variable 1st LO (1st IF fixed) driving an external mixer. The first IF, which can range from 10 MHz to 26.5 GHz (18 GHz) is further down converted by the HP 8971C (HP 8971B) and its LO into the frequency range of the HP 8970B. If the 1st IF can be reduced below 1600 MHz (2047 MHz, opt 020), then Measurement 1.1 is a better choice than Measurement 1.6; since Measurement Mode 1.1 requires less equipment, less noise figure is contributed by the measurement system, and a preamplifier may not be required. The typical DUT is an amplifier or a transistor. All the Measurement Modes can be set up to use many of the capabilities of the Noise Figure Meter. For example, each mode can make either UNCORRECTED NOISE FIGURE or CORRECTED NOISE FIGURE AND GAIN measurements, plus the measurement results for each mode can be displayed on an oscilloscope and output to a recorder or plotter.

NOTE

The Noise Figure Meter has limited control of the user controlled LO. However, in the following text the user controlled LO is not controlled by the Noise Figure Meter; the user must control the LO. Refer to the Comments section at the end of this instruction for an explanation of how to have the Noise Figure Meter control the LO.

Requirement

The following minimum requirements are necessary for the Noise Figure Measurement System to operate in Measurement Mode 1.6.

Measurement Mode 1.6 (cont'd) (Special Function 1.6)

Requirement (cont'd)

- a. The Noise Figure Test Set and the system local oscillator must be connected to the Noise Figure Meter's SYSTEM INTERFACE BUS connector with an HP-IB cable.
- b. Special Function 48.0 must be active (Noise Figure Meter is the system controller on the system interface bus; Special Function 48.0 is the default setting, after using Special Function 0.9).
- c. Special Function 45.0 must be active (Noise Figure Test Set enabled in measurement modes 1.5 through 1.9; Special Function 45.0 is the default setting, after using Special Function 0.9.) or Special Function 45.1 (Noise Figure Test Set enabled always) must be active.
- d. The address of the Noise Figure Test Set must match the Noise Figure Test Set address that is stored in the Noise Figure Meter. Use Special Function 40.2 (Noise Figure Test Set address) to display and change the address if necessary. The default address of the Noise Figure Test Set is 10, after using Special Function 0.9.
- e. Special Function 46.0 must be active (Enable system local oscillator on System Interface Bus; Special Function 46.0 is the default setting, after using Special Function 0.9.).
- f. The address of the system local oscillator must match the address of the system local oscillator stored in the Noise Figure Meter. Use Special Function 40.1 (system local oscillator System Interface Bus address) to display and change this address, if necessary. The default address is 19, after using Special Function 0.9.
- g. The correct system local oscillator program must be active if the Noise Figure Meter is going to control the system local oscillator. The system local oscillator programs are listed below:
 - HP 8671B/8672A Synthesized Signal Generators; Special Function 41.2
 - HP 8673B/C/G (Standard) Synthesized Signal Generator; Special Function 41.3
 - HP 8340B/8341B Sweep Oscillator; Special Function 41.4
 - Custom local oscillator; Special Function 41.5

The custom local oscillator program will support local oscillators that may require a maximum of twenty-two characters for the frequency prefix and suffix and/or the output power prefix and suffix. The prefix and suffix define the command sequence that will set the frequency or output power.

Use Special Function 42 to define a new program for other system local oscillators.

Procedure

NOTE

High measurement system noise figure leads to high measurement uncertainty, when measuring low gain devices. A low noise preamplifier, between the device under test and the measurement system, can lower system noise figure and therefore reduce the measurement uncertainty. For more information on determining if a preamplifier is needed and selection of the preamplifier, refer to Application Note 57-2.

Measurement Mode 1.6 (cont'd)

(Special Function 1.6)

Procedure (cont'd)

- a. Verify that the minimum requirements specified under Requirements are satisfied.
- b. Press PRESET.
- c. Press 1.6 SPECIAL FUNCTION to set the Noise Figure Meter to Measurement Mode 1.6.
- d. Set frequency parameters (including the fixed IF, Special Function 3.0).
- e. Select sideband operation desired. (Special Function 2 and 17)
- f. Select appropriate smoothing (Special Function 13).
- g. Enter the ENR table of the noise source.
- h. Perform a Noise Figure Test Set fine tuning calibration. For more information, refer to the Noise Figure Test Set YIG Filter Calibration Detailed Operating Instruction.
- i. Perform a triggered calibration of the Noise Figure Measurement System, with the device under test (DUT) out of the measurement system, in Mode 1.6 (this is only required for a CORRECTED NOISE FIGURE AND GAIN measurement). The user controlled local oscillator must be set up for each of the calibration points. If external filtering and a preamplifier are required for the measurement, external filtering and the preamplifier must be used during calibration.
- j. Insert the DUT into the measurement system and make a noise figure or noise figure and gain measurement.

Example

To make a swept single sideband CORRECTED NOISE FIGURE AND GAIN measurement in the 20 to 24 GHz range in 200 MHz steps with a fixed IF of 3.5 GHz.

NOTE

This example assumes that the Noise Figure Meter is acting as a controller and the minimum requirements specified under Requirements are satisfied. Refer to Comments for a brief description of using an external controller when in Measurement Mode 1.6.

- a. Press PRESET to establish initial conditions.

NOTE

Single sideband (Special Function 17.0) was enabled, for the Noise Figure Test Set, when PRESET was pressed.

Measurement Mode 1.6 must be activated prior to entering the frequency parameters to avoid error E35 (entered value is out of range).

- b. Press 1.6 SPECIAL FUNCTION to activate Measurement Mode 1.6.
- c. Set the frequency parameters for both the calibration and measurement.

Measurement Mode 1.6 (cont'd) (Special Function 1.6)

**Example
(cont'd)**

d. Enter actual ENR for the noise source, if this has not previously been done.

e. Press 2.1 SPECIAL FUNCTION to select a lower sideband measurement. Special Function 2.1 is used to select the sideband operation desired for the first frequency conversion, using the user controlled local oscillator and the external mixer.

NOTE

When a single sideband measurement is being made, the user must place a filter between the device under test and the external mixer to eliminate the unwanted sideband.

f. Configure the user controlled local oscillator to produce a 3.5 GHz IF at the input of the Noise Figure Measurement System. The correct frequency to set the user controlled local oscillator to can be viewed by using Special Function 3.2.

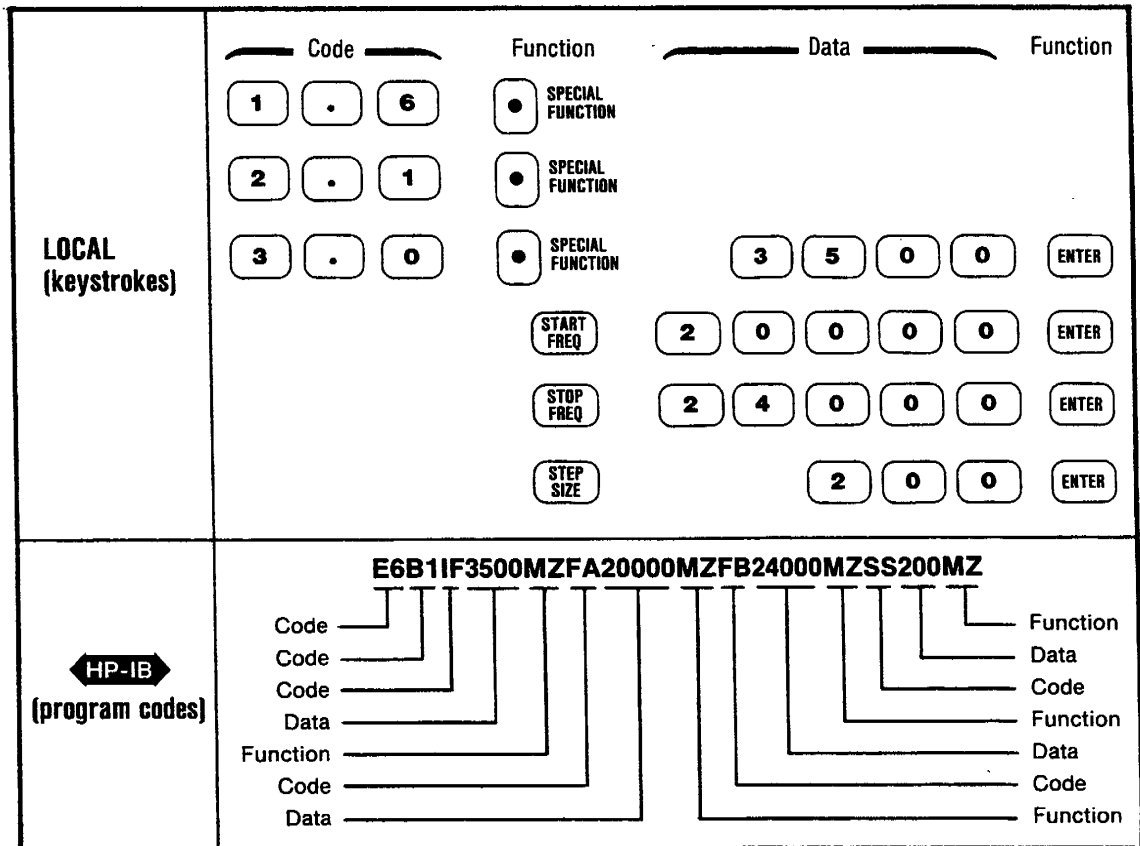

g. To calibrate the Noise Figure Measurement System and perform a Noise Figure Test Set Fine Tuning Calibration, set up the equipment as shown below.

Measurement Mode 1.6 (cont'd) (Special Function 1.6)

Example
(cont'd)

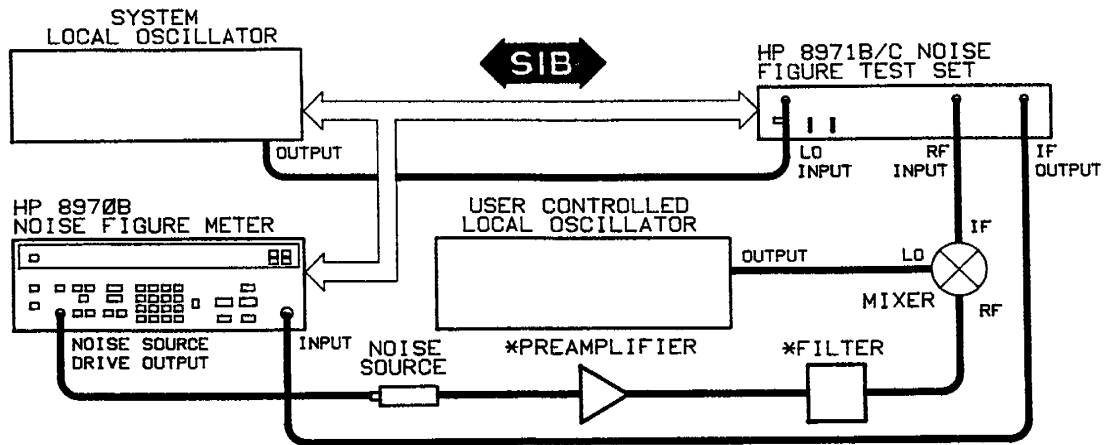

*IF THE PREAMPLIFIER AND FILTER ARE NEEDED DURING THE MEASUREMENT (THE FILTER IS ADDED IF A SINGLE SIDEBAND MEASUREMENT IS BEING MADE), THEY NEED TO BE USED DURING CALIBRATION.

Figure 3-31. Measurement Mode 1.6 Calibration Setup

NOTE

A Noise Figure Test Set Fine Tuning Calibration may need to be done separately from the measurement system calibration (step h). The separate fine tuning calibration is needed if a mixer is being used out in front of the Noise Figure Measurement System and a preamplifier is not being used. An Excess Noise Ratio (ENR) of 13 dB or greater is needed at the input to the Noise Figure Test Set during the fine tuning calibration.

h. Calibrate and fine tune in Measurement Mode 1.6 by performing a triggered calibration. The user controlled local oscillator frequency must be set up before the Noise Figure Meter is triggered. PRESET enabled a fine tune (Special Function 36.0) to be done each time a calibration is done. Enable the calibration and fine tune by pressing the CALIBRATE key twice.

i. To make the measurement, set up the equipment as shown below.

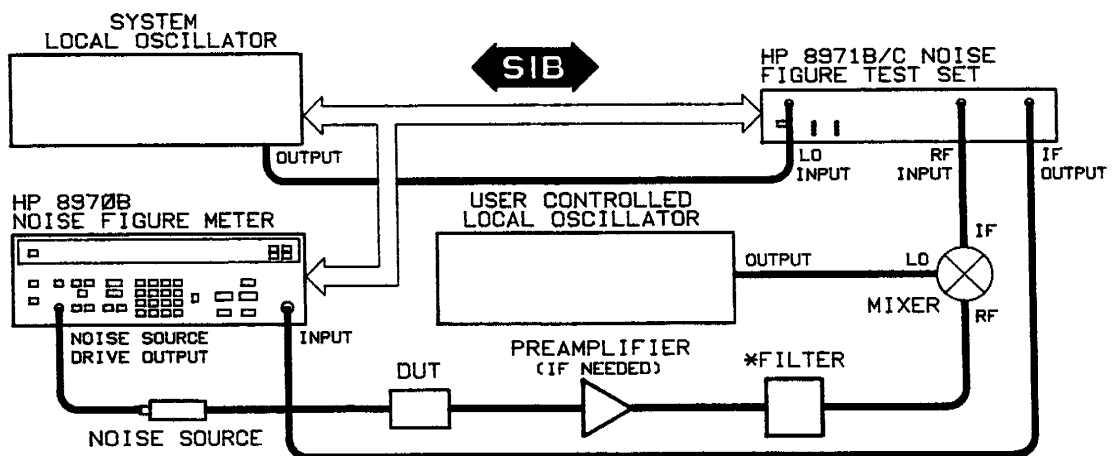

*THE FILTER IS ADDED IF A SINGLE SIDEBAND MEASUREMENT IS BEING MADE.

Figure 3-32. Measurement Mode 1.6 Setup

Measurement Mode 1.6 (cont'd)

(Special Function 1.6)

Example (cont'd)

NOTE

For the Noise Figure Measurement System specifications to be valid, the measurement must use the same START FREQ, STOP FREQ and STEP SIZE that was used for calibration. None of the calibrated points can be skipped. Also, the measurement must be done in the same direction as the calibration, for example, from start frequency to stop frequency.

j. Press CORRECTED NOISE FIGURE AND GAIN.

k. Perform a triggered sweep of the user controlled local oscillator and the Noise Figure Measurement System to gather the data.

Program Codes

HP-IB

The HP-IB code for Measurement Mode 1.6 is E6 (or 1.6SP). Refer to Comments for additional information on using HP-IB program codes in Measurement Mode 1.6.

Indications

The left display shows each frequency at which a measurement is made and the EXT MIX annunciator lights. The INSERTION GAIN display shows the gain of the DUT at the displayed frequency. The NOISE FIGURE display shows the noise figure of the DUT at the displayed frequency.

Comments

An external controller can be used to control the Noise Figure Measurement System and the user controlled local oscillator. The following general conditions must be observed when using an external controller:

a. The external controller and the user controlled local oscillator must be connected to the HP-IB connector on the Noise Figure Meter.

b. HP-IB code H1 must be active.

c. Special Function 4.0 (normal talker and listener) must be active. Note that there is no HP-IB code for this special function.

d. Special Function 30.1 (trigger hold) must be active (HP-IB code is T1).

e. The correct measurement parameters (for example, Measurement Mode, frequencies, etc.) must be established. Refer to Table 3-9, Special Function to HP-IB Code Summary and Table 3-10, Front Panel Keys to HP-IB Code Summary for applicable HP-IB codes.

f. Perform a triggered Noise Figure Test Set Fine Tuning Calibration and Noise Figure Measurement System Calibration with the DUT out of the measurement system (refer to the Calibrate Detailed Operating Instruction and the Noise Figure Test Set YIG Filter Calibration Detailed Operating Instruction).

A Noise Figure Test Set Fine Tuning Calibration may need to be done separately from the measurement system calibration. The separate fine tuning calibration is needed if a mixer is being used out in front of the Noise Figure Measurement System and a preamplifier is not being used. An ENR (Excess Noise Ratio) of 13 dB or greater is needed at the input to the Noise Figure Test Set during the fine tuning calibration.

Measurement Mode 1.6 (cont'd)

(Special Function 1.6)

Comments (cont'd)

g. Set the Noise Figure Meter's calibrate function on (HP-IB code is CA).

h. Set the user controlled local oscillator to the desired frequency, depending on the sideband selection. If double sideband was selected, the oscillator should be set to the measurement frequency. If lower sideband was selected, the oscillator should be set to the measurement frequency plus the IF. If upper sideband was selected, the oscillator should be set to the measurement frequency minus the IF. If sum (upconversion; Special Function 2.3) was selected, set the oscillator to the IF minus the measurement frequency. Refer to the user controlled local oscillator's operating manual for the required HP-IB codes. Allow sufficient time for the output of the user controlled local oscillator to stabilize.

i. Trigger a measurement using the HP-IB code T2. Do not use the alternate HP-IB code 30.2SP for it will be ignored.

j. A method must be determined when to step to a new frequency after reading the noise figure results. This read operation cannot be completed until the new data is ready. It is possible to write an SRQ interrupt routine on the Data Ready status bit. Refer to Enabling the Service Request Condition, paragraph 3-30.

k. Continue to loop through steps h, i and j. A method for determining when the calibration will be completed must be programmed into the external controller. One method is to compare the frequency that is sent to the user LO with the stop frequency programmed into the Noise Figure Meter and terminate the program after the third measurement in which they are equal. It is also possible to write an SRQ interrupt routine on the Calibration Complete Status Bit. Refer to Enabling the Service Request Condition, paragraph 3-30.

l. Insert the device under test (DUT) into the measurement system.

m. Set the Noise Figure Meter's SINGLE sweep on (HP-IB code is W2) or AUTO sweep on (HP-IB code is W1).

n. Repeat step h.

o. Trigger a measurement using the HP-IB code T2. Do not use the alternate HP-IB code 30.2SP for Special Function 30.2 as it will reset the sweep.

p. A method must be determined when to step to a new frequency after reading the noise figure results. This read operation cannot be completed until the new data is ready. It is possible to write an SRQ interrupt routine on the Data Ready Status Bit. Refer to Enabling the Service Request Condition, paragraph 3-30.

q. Continue to loop through steps n, o and p. A method for determining when the measurements are complete must be programmed into the external controller. One method is to compare the measurement frequency read from the Noise Figure Meter with the stop frequency programmed into the Noise Figure Meter and terminate the program after the measurement in which they are equal.

Measurement Mode 1.6 (cont'd)

(Special Function 1.6)

Comments (cont'd)

User Controlled Local Oscillator Control

The Noise Figure Meter can control the user controlled LO to a limited extent. If the system LO and the user controlled LO are to be controlled by the same predefined program (Special Function 41), control is limited to setting the frequency prefix and suffix (Special Function 42.1). The frequency prefix and suffix are used to properly format the command sequence that will set the LO's output frequency. If the user controlled LO is to be controlled by the custom LO program (Special Function 41.5) and the system LO is controlled by another predefined program, the Noise Figure Meter has increased control of the user controlled LO. The additional control can include setting the output power level and turning off any modulation. The Noise Figure Meter will not check to see if an out of range frequency has been sent to the user controlled LO. Also, a variable settling time is not allowed. A default settling time of 200 ms is always used.

Add the following steps to the Requirements section at the beginning of the measurement instruction:

NOTE

Any steps within the measurement instruction that say to set the user controlled LO manually may be ignored. Where the user controlled LO was set manually the Noise Figure Meter will set the LO.

- a. The user controlled LO must be connected to the Noise Figure Meter's SYSTEM INTERFACE BUS.
- b. Special Function 96.1 must be active (Enable the user controlled LO on the System Interface bus).
- c. The address of the user controlled LO must match the address of the user controlled LO stored in the Noise Figure Meter. Use Special Function 96.2 (user controlled LO System Interface Bus address) to display and change this address if necessary. The default address is 20, after using Special Function 0.9.

NOTE

If Special Function 96.1 is active (enable the user controlled LO) and the Noise Figure Meter can't find the LO at the address set by Special Function 96.2, error code E106 will be displayed.

- d. Special Function 96.3 must be used to let the Noise Figure Meter know if the system LO and the user controlled LO are using the same predefined program (Special Function 41). Or, if the user controlled LO will be controlled by the custom LO program (Special Function 41.5). If the two LOs are being controlled by the same predefined program, zero is entered after Special Function 96.3 is enabled. If the user controlled LO is being controlled by the custom LO program, one is entered after Special Function 96.3 is enabled. The procedure is to key in 96.3, press SPECIAL FUNCTION, key in 0 or 1 and press ENTER.

If the system LO and the user controlled LO are to be controlled by the same program, the Noise Figure Meter has limited control of the user controlled LO. Control is limited to setting the frequency prefix and suffix. All other commands must be set manually.

If the user controlled LO is to be controlled by the custom LO program and the system LO is controlled by another predefined program, the Noise Figure Meter has increased control of the user controlled LO. The increased control can include setting the power level and other commands. When the custom LO program is used, only the frequency

Measurement Mode 1.6 (cont'd) (Special Function 1.6)

**Comments
(cont'd)**

prefix and suffix section (Special Function 42.7) is valid. All commands are set using Special Function 42.7. The frequency prefix and suffix can have a total of twenty-two characters. Plus there are two characters (count characters) that are used to indicate the number of characters in the prefix and in the suffix. Since the maximum number of characters in the prefix and suffix is twenty-two, the frequency prefix and suffix determines the number of additional commands that can be added. The output power level and any other commands are placed in the frequency suffix.

The following procedure outlines the steps needed to setup the custom LO program to control the user controlled LO:

NOTE

When the user controlled LO is controlled by the custom LO program, Special Function 41.5 is NOT enabled. If Special Function 41.5 were to be enabled, the predefined program controlling the system LO would be replaced by the custom LO program. This would be an undesirable condition. Control of the user controlled LO is accomplished using Special Function 42.7. With Special Function 96.3 set to 1, the frequency prefix and suffix defined by Special Function 42.7 will be used, without having Special Function 41.5 active.

1. Special Function 42.7 must be active (frequency prefix and suffix). This allows modification of the frequency prefix and suffix.
2. Modify the frequency prefix by entering the decimal count for the number of characters in the prefix followed by the decimal equivalents of the required ASCII prefix characters. Then, enter the decimal count for the number of suffix characters followed by the decimal equivalents of the ASCII suffix characters. With Special Function 42.7 active, the decimal values are entered using the front panel key pad. Each time a decimal is keyed in, the ENTER key is pressed. For additional information refer to the Programming The System LO Detailed Operating Instruction (Example 2, Using the Custom Local Oscillator Program).

For example, the desired characters could be as follows:

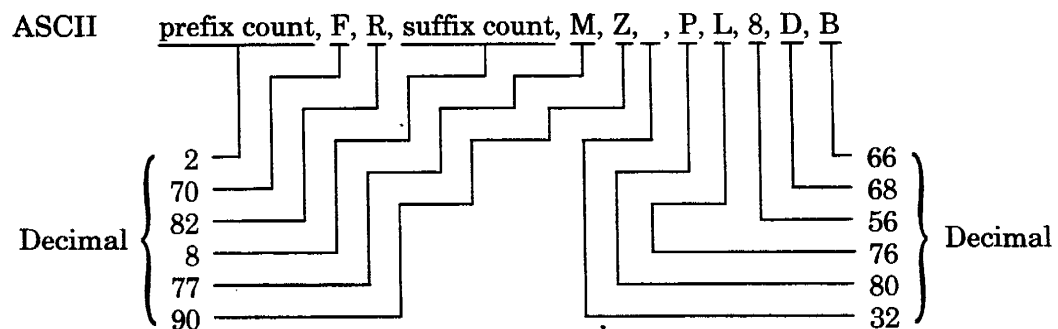

Where 2 is the number of characters in the prefix. "FR" (decimal 70 and 82) is the frequency prefix. 8 is the number of characters in the suffix. "MZ" (decimal 77 and 90) is the frequency suffix followed by a space (decimal 32). "PL" (decimal 80 and 76) is the power prefix. 8 (decimal 56) is the power level. "DB" (decimal 68 and 66) is the power suffix.

Measurement Mode 1.6 (cont'd)

(Special Function 1.6)

Comments (cont'd)

A space can be used between each command set. As the example shows a space was placed between the frequency prefix and suffix and the power setting command.

In the example ten characters were used. Since twenty-two characters can be used between the frequency prefix and suffix, twelve more characters could be added to the suffix to control other functions.

- e. Pressing the FREQUENCY key will exit the user from special function 42.7.

Related Sections

Calibrate
Controller Capability of the Noise Figure Meter
Fixed IF Selection
Measurement Modes
Noise Figure Test Set YIG Filter Calibration
Sideband Selection
Special Functions
Trigger Selection

Measurement Mode 1.7 (Special Function 1.7)

Description

Measurement mode 1.7 is for DUTs with no frequency conversion and operating at frequencies greater than 26.5 GHz. The measurement system is single sideband and double conversion. The 1st conversion is done using an external mixer and a fixed LO (wideband 1st IF). The HP 8971C and its LO perform the second conversion using a variable LO to produce a fixed 2nd IF in the range of the HP 8970B Option 020. This is a convenient measurement system to cover a wide measurement bandwidth at millimeter frequencies with a less expensive fixed 1st LO. Wideband filters preceding the system's first mixer are used to eliminate the image to obtain single sideband measurements. (Typically these filters are either lowpass or "waveguide beyond cutoff" highpass structures). The typical DUT is an amplifier or a transistor. All the Measurement Mode can be set up to use many of the other capabilities of the Noise Figure Meter. For example, each mode can make either UNCORRECTED NOISE FIGURE or CORRECTED NOISE FIGURE AND GAIN measurements, plus the measurement results for each mode can be displayed on an oscilloscope and output to a recorder or plotter.

NOTE

The Noise Figure Meter has limited control of the user controlled LO. However, in the following text the user controlled LO is not controlled by the Noise Figure Meter; the user must control the LO. Refer to the Comments section at the end of this instruction for an explanation of how to have the Noise Figure Meter control the LO.

Requirements

The following minimum requirements are necessary for the Noise Figure Measurement System and the user controlled local oscillator to operate in Measurement Mode 1.7.

Measurement Mode 1.7 (cont'd) (Special Function 1.7)

Requirements (cont'd)

- a. The system local oscillator and the Noise Figure Test Set must be connected to the Noise Figure Meter's SYSTEM INTERFACE BUS connector with an HP-IB cable.
 - b. Special Function 48.0 must be active (Noise Figure Meter is system controller on System Interface Bus; Special Function 48.0 is the default setting, after using Special Function 0.9).
 - c. Special Function 45.0 must be active (Noise Figure Test Set enabled in measurement modes 1.5 through 1.9; Special Function 45.0 is the default setting, after using Special Function 0.9.) or Special Function 45.1 (Noise Figure Test Set enabled always) must be active.
 - d. The address of the Noise Figure Test Set must match the Noise Figure Test Set address that is stored in the Noise Figure Meter. Use Special Function 40.2 (Noise Figure Test Set System Interface Bus address) to display and change this address if necessary. The default address for the Noise Figure Test Set is 10, after using Special Function 0.9.
 - e. Special Function 46.0 must be active (Enable system local oscillator on System Interface Bus; Special Function 46.0 is the default setting, after using Special Function 0.9.).
 - f. The address of the system local oscillator must match the address of the system local oscillator stored in the Noise Figure Meter. Use Special Function 40.1 (system local oscillator System Interface Bus address) to display and change this address if necessary. The default address is 19, after using Special Function 0.9.
 - g. The correct system local oscillator program must be active if the Noise Figure Meter is going to control the system local oscillator. The system local oscillator programs are listed below:
 - HP 8671B/8672A Synthesized Signal Generators; Special Function 41.2
 - HP 8673B/C/G (Standard) Synthesized Signal Generator; Special Function 41.3
 - HP 8340B/8341B Sweep Oscillator; Special Function 41.4
 - Custom local oscillator; Special Function 41.5
- The custom local oscillator program will support local oscillators that may require a maximum of twenty-two characters for the frequency prefix and suffix and/or the output power prefix and suffix. The prefix and suffix define the command sequence that will set the frequency or output power.
- Use Special Function 42 to define a new program for other system local oscillators.
- h. The user controlled local oscillator must be configured to produce the desired IF (10 to 26500 MHz). The user controlled local oscillator is not controlled by the Noise Figure Meter.

Procedure

There are many possible measurement procedures. However, the following general procedure applies to all cases:

Measurement Mode 1.7 (cont'd)

(Special Function 1.7)

Procedure (cont'd)

NOTE

High measurement system noise figure leads to high measurement uncertainty, when measuring low gain devices. A low noise preamplifier, between the device under test and the measurement system, can lower system noise figure and therefore reduce the measurement uncertainty. For more information on determining if a preamplifier is needed and selection of the preamplifier, refer to Application Note 57-2.

- a. Verify that the minimum requirements specified under Requirements are satisfied.
- b. Press PRESET.
- c. Press 1.7 SPECIAL FUNCTION to set the Noise Figure Meter to Measurement Mode 1.7.
- d. Set frequency parameters (including the fixed frequency for the user controlled local oscillator, Special Function 3.1).
- e. Select sideband operation desired (Special Functions 2.1 through 2.3 and 17; Special Function 2.1 is the default.)
- f. Select appropriate smoothing (Special Function 13).
- g. Enter the noise source ENR table.
- h. Set the user controlled local oscillator to the frequency specified by Special Function 3.1.
- i. Perform a Noise Figure Test Set Fine Tuning Calibration. For more information, refer to the Noise Figure Test Set YIG Filter Calibration Detailed Operating Instruction.
- j. Calibrate the Noise Figure Measurement System in Mode 1.7 (this is only required for a CORRECTED NOISE FIGURE AND GAIN measurement). External filtering is required during both calibration and the measurement. If a preamplifier is required for the measurement, the preamplifier must be used in the calibration.
- k. Insert DUT and make a noise figure or noise figure and gain measurement.

Example

NOTE

The following example assumes that the Noise Figure Meter is the controller. An external controller can be used to control the Noise Figure Measurement System and the user controlled local oscillator. For more information on using an external controller, refer to Comments at the end of this instruction.

To make a swept CORRECTED NOISE FIGURE AND GAIN measurement of a wideband amplifier in the 20 to 30 GHz range using 200 MHz steps:

Measurement Mode 1.7 (cont'd)

(Special Function 1.7)

Example (cont'd)

a. Press PRESET (or send HP-IB code PR) to establish initial conditions. PRESET selects a single sideband measurement (Special Function 17.0) for the Noise Figure Test Set.

NOTE

Measurement Mode 1.7 must be activated prior to entering the frequency parameters to avoid error E35 (entered value is out of range).

b. Press 1.7 SPECIAL FUNCTION (or send HP-IB code E7) to activate Mode 1.7.

c. Special Function 2.1 was activated when Special Function 1.7 was enabled. Special Function 2.1 is used to select single sideband operation for the first frequency conversion, using the user controlled local oscillator and the external mixer.

NOTE

When a single sideband measurement is being made, the user must place a filter between the device under test and the external mixer to eliminate the unwanted sideband.

d. Set the frequency parameters for both the calibration and measurement.

e. Enter the noise source ENR table, if this has not already been done.

f. Set the user controlled local oscillator to the frequency specified by Special Function 3.1.

Measurement Mode 1.7 (cont'd) (Special Function 1.7)

Example
(cont'd)

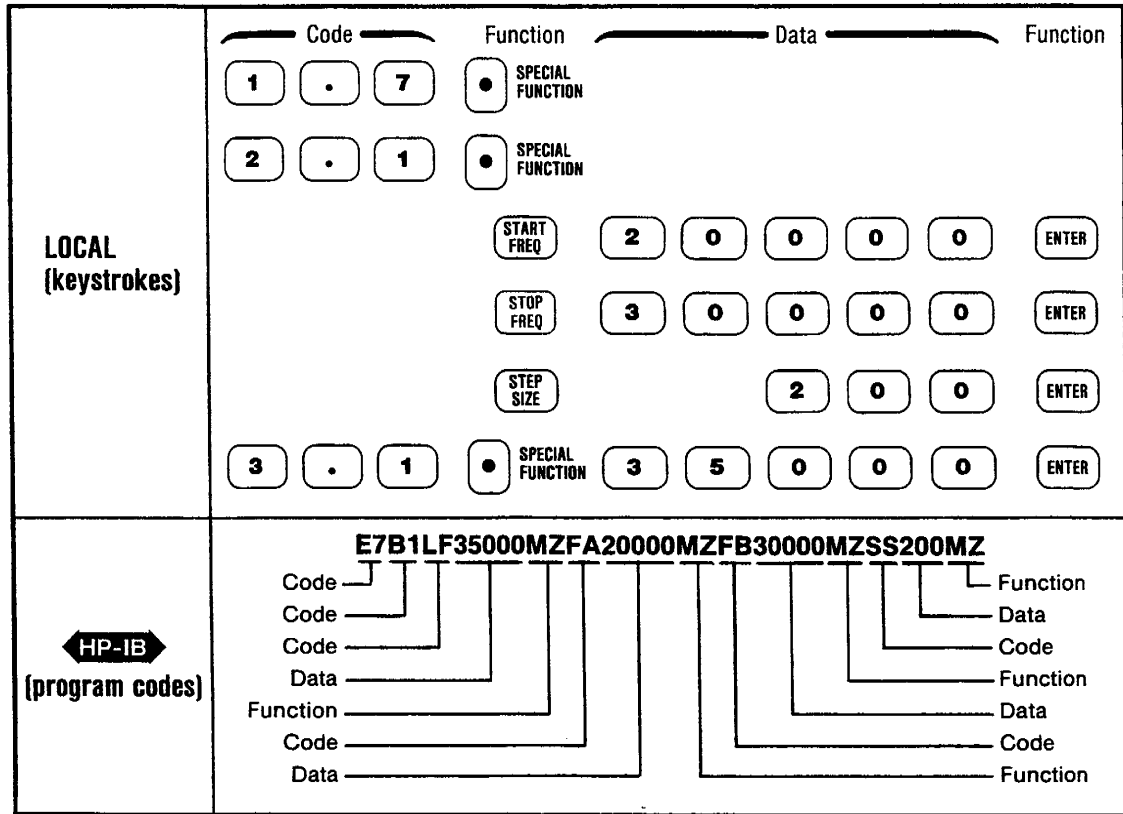

g. To calibrate the Noise Figure Measurement System and perform a Noise Figure Test Set Fine Tuning Calibration, set up the equipment as shown below. Ensure the user controlled local oscillator frequency is set before calibration. PRESET enabled a fine tuning calibration (Special Function 36.0) each time the Noise Figure Measurement System is calibrated.

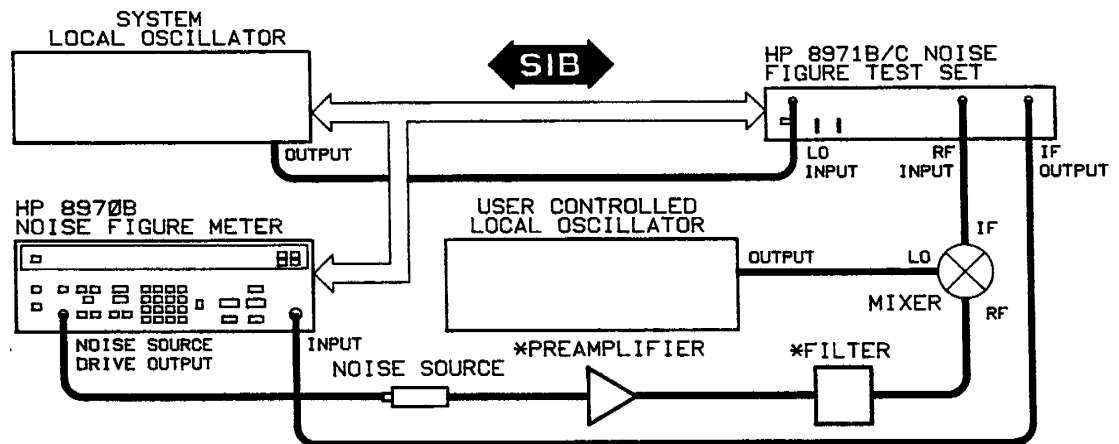

*IF THE PREAMPLIFIER AND FILTER ARE NEEDED DURING THE MEASUREMENT (THE FILTER IS ADDED IF A SINGLE SIDEBAND MEASUREMENT IS BEING MADE), THEY NEED TO BE USED DURING CALIBRATION.

Figure 3-33. Measurement Mode 1.7 Calibration Setup

Measurement Mode 1.7 (cont'd)

(Special Function 1.7)

Example (cont'd)

NOTE

A Noise Figure Test Set Fine Tuning Calibration may need to be done separately from the measurement system calibration (step h). The separate fine tuning calibration is needed if a mixer is being used out in front of the Noise Figure Measurement System and a preamplifier is not being used. An Excess Noise Ratio (ENR) of 13 dB or greater is needed at the input to the Noise Figure Test Set during the fine tuning calibration.

h. Calibrate and fine tune the equipment in Measurement Mode 1.7 by pressing CALIBRATE twice (or sending HP-IB code CA).

i. To make the measurement, set up the equipment as shown below.

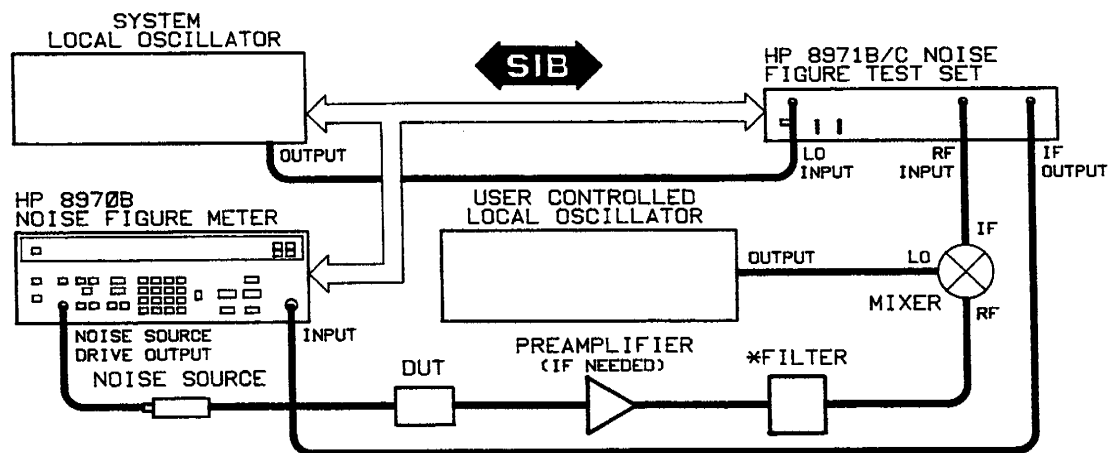

*THE FILTER IS ADDED IF A SINGLE SIDEBAND MEASUREMENT IS BEING MADE.

Figure 3-34. Measurement Mode 1.7 Setup

NOTE

For the Noise Figure Measurement System specifications to be valid, the measurement must use the same START FREQ, STOP FREQ and STEP SIZE that was used for calibration. None of the calibrated points can be skipped. Also, the measurement must be done in the same direction as the calibration, for example, from start frequency to stop frequency.

This example assumes that the user controlled local oscillator is tuned to the specified frequency of 35 GHz.

j. Press CORRECTED NOISE FIGURE AND GAIN (or send HP-IB code M2).

k. Press SINGLE (or send HP-IB code W2). The Noise Figure Measurement System will sweep from 15000 to 5000 MHz in 200 MHz steps but will display the microwave measurement frequency of 20000 to 30000 MHz. After the single sweep is completed, the instrument halts.

Measurement Mode 1.7 (cont'd)

(Special Function 1.7)

Program Codes

HP-IB

The HP-IB code for Measurement Mode 1.7 is E7 (or 1.7SP). Additional HP-IB codes are given, in the Comments section, when using an external controller.

Indications

The left display shows each frequency at which a measurement is made and the EXT MIX annunciator lights. The INSERTION GAIN display shows the gain of the DUT at the displayed frequency. The NOISE FIGURE display shows the noise figure of the DUT at the displayed frequency.

Comments

An external controller can be used to control the Noise Figure Measurement System and the user controlled local oscillator in Measurement Mode 1.7. The following general conditions must be observed when using an external controller:

- a. The external controller and the user controlled local oscillator must be connected to the HP-IB connector on the Noise Figure Meter.
 - b. HP-IB code H1 must be active.
 - c. Special Function 4.0 (normal talker and listener) must be active. Note that there is no HP-IB code for this special function.
 - d. Special Function 30.0 (free run) must be active (HP-IB code is T0).
 - e. The correct measurement parameters (for example, Measurement Mode, frequencies, etc.) must be established. Refer to Table 3-9, Special Function to HP-IB Code Summary, and Table 3-10, Front Panel Keys to HP-IB Code Summary, for applicable HP-IB codes.
 - f. Set the user controlled local oscillator to the appropriate frequency. Refer to the local oscillator's operating manual for the required HP-IB codes. Allow sufficient time for the output of the local oscillator to stabilize.
 - g. Perform a Noise Figure Test Set Fine Tuning Calibration and a Noise Figure Measurement System Calibration with the DUT out of the measurement system (refer to the Calibrate Detailed Operating Instruction and the Noise Figure Test Set YIG Filter Calibration Detailed Operating Instruction).
- A Noise Figure Test Set Fine Tuning Calibration may need to be done separately from the measurement system calibration. The separate fine tuning calibration is needed if a mixer is being used out in front of the Noise Figure Measurement System and a preamplifier is not being used. An Excess Noise Ratio (ENR) of 13 dB or greater is needed at the input to the Noise Figure Test Set during the fine tuning calibration.
- h. Send the command "RM 2EN RS CA." Wait for a serial poll to return a non-zero value, indicating calibration is complete.
 - i. Insert the DUT into the measurement system.
 - j. Special Function 30.1 (trigger hold) must be active (HP-IB code is T1).

Measurement Mode 1.7 (cont'd)

(Special Function 1.7)

Comments (cont'd)

k. Set the Noise Figure Meter's SINGLE sweep on (HP-IB code is W2) or AUTO sweep on (HP-IB code is W1).

l. Trigger a measurement using the HP-IB code T2. Do not use the alternate HP-IB code 30.2SP for Special Function 30.2 as it will reset the sweep.

m. A method must be determined when to step to a new frequency after reading the noise figure results. This read operation cannot be completed until the new data is ready. It is possible to write an SRQ interrupt routine on the Data Ready Status Bit. Refer to Enabling the Service Request Condition, paragraph 3-30.

n. Continue to loop through steps l and m. A method for determining when the measurements are complete must be programmed into the external controller. One method is to compare the measurement frequency that is read from Noise Figure Meter with the stop frequency programmed into the Noise Figure Meter and terminate the program after the measurement in which they are equal.

User Controlled Local Oscillator Control

The Noise Figure Meter can control the user controlled LO to a limited extent. If the system LO and the user controlled LO are to be controlled by the same predefined program (Special Function 41), control is limited to setting the frequency prefix and suffix (Special Function 42.1). The frequency prefix and suffix are used to properly format the command sequence that will set the LO's output frequency. If the user controlled LO is to be controlled by the custom LO program (Special Function 41.5) and the system LO is controlled by another predefined program, the Noise Figure Meter has increased control of the user controlled LO. The additional control can include setting the output power level and turning off any modulation. The Noise Figure Meter will not check to see if an out of range frequency has been sent to the user controlled LO. Also, a variable settling time is not allowed. A default settling time of 200 ms is always used.

Add the following steps to the Requirements section at the beginning of the measurement instruction:

NOTE

Any steps within the measurement instruction that say to set the user controlled LO manually may be ignored. Where the user controlled LO was set manually the Noise Figure Meter will set the LO.

a. The user controlled LO must be connected to the Noise Figure Meter's SYSTEM INTERFACE BUS.

b. Special Function 96.1 must be active (Enable the user controlled LO on the System Interface bus).

c. The address of the user controlled LO must match the address of the user controlled LO stored in the Noise Figure Meter. Use Special Function 96.2 (user controlled LO System Interface Bus address) to display and change this address if necessary. The default address is 20, after using Special Function 0.9.

NOTE

If Special Function 96.1 is active (enable the user controlled LO) and the Noise Figure Meter can't find the LO at the address set by Special Function 96.2, error code E106 will be displayed.

Measurement Mode 1.7 (cont'd)

(Special Function 1.7)

Comments (cont'd)

d. Special Function 96.3 must be used to let the Noise Figure Meter know if the system LO and the user controlled LO are using the same predefined program (Special Function 41). Or, if the user controlled LO will be controlled by the custom LO program (Special Function 41.5). If the two LOs are being controlled by the same predefined program, zero is entered after Special Function 96.3 is enabled. If the user controlled LO is being controlled by the custom LO program, one is entered after Special Function 96.3 is enabled. The procedure is to key in 96.3, press SPECIAL FUNCTION, key in 0 or 1 and press ENTER.

If the system LO and the user controlled LO are to be controlled by the same program, the Noise Figure Meter has limited control of the user controlled LO. Control is limited to setting the frequency prefix and suffix. All other commands must be set manually.

If the user controlled LO is to be controlled by the custom LO program and the system LO is controlled by another predefined program, the Noise Figure Meter has increased control of the user controlled LO. The increased control can include setting the power level and other commands. When the custom LO program is used, only the frequency prefix and suffix section (Special Function 42.7) is valid. All commands are set using Special Function 42.7. The frequency prefix and suffix can have a total of twenty-two characters. Plus there are two characters (count characters) that are used to indicate the number of characters in the prefix and in the suffix. Since the maximum number of characters in the prefix and suffix is twenty-two, the frequency prefix and suffix determines the number of additional commands that can be added. The output power level and any other commands are placed in the frequency suffix.

The following procedure outlines the steps needed to setup the custom LO program to control the user controlled LO:

NOTE

When the user controlled LO is controlled by the custom LO program, Special Function 41.5 is NOT enabled. If Special Function 41.5 were to be enabled, the predefined program controlling the system LO would be replaced by the custom LO program. This would be an undesirable condition. Control of the user controlled LO is accomplished using Special Function 42.7. With Special Function 96.3 set to 1, the frequency prefix and suffix defined by Special Function 42.7 will be used, without having Special Function 41.5 active.

1. Special Function 42.7 must be active (frequency prefix and suffix). This allows modification of the frequency prefix and suffix.
2. Modify the frequency prefix by entering the decimal count for the number of characters in the prefix followed by the decimal equivalents of the required ASCII prefix characters. Then, enter the decimal count for the number of suffix characters followed by the decimal equivalents of the ASCII suffix characters. With Special Function 42.7 active, the decimal values are entered using the front panel key pad. Each time a decimal is keyed in, the ENTER key is pressed. For additional information refer to the Programming The System LO Detailed Operating Instruction (Example 2, Using the Custom Local Oscillator Program).

For example, the desired characters could be as follows:

Measurement Mode 1.7 (cont'd) (Special Function 1.7)

**Comments
(cont'd)**

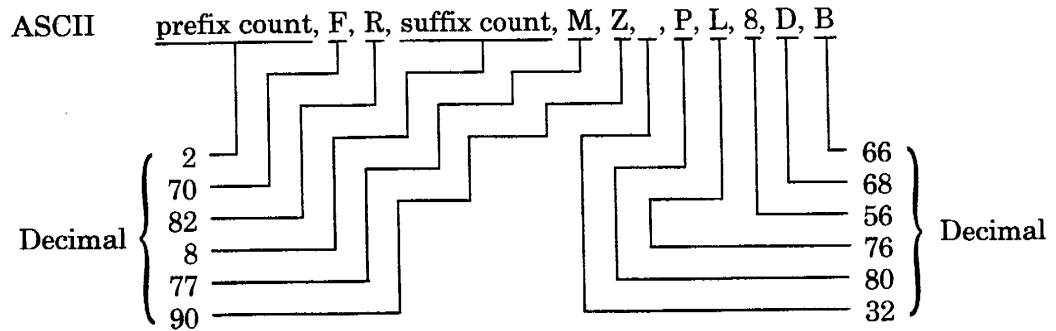

Where 2 is the number of characters in the prefix. "FR" (decimal 70 and 82) is the frequency prefix. 8 is the number of characters in the suffix. "MZ" (decimal 77 and 90) is the frequency suffix followed by a space (decimal 32). "PL" (decimal 80 and 76) is the power prefix. 8 (decimal 56) is the power level. "DB" (decimal 68 and 66) is the power suffix.

A space can be used between each command set. As the example shows a space was placed between the frequency prefix and suffix and the power setting command.

In the example ten characters were used. Since twenty-two characters can be used between the frequency prefix and suffix, twelve more characters could be added to the suffix to control other functions.

- e. Pressing the FREQUENCY key will exit the user from special function 42.7.

**Related
Sections**

- Calibrate
- Controller Capability of the Noise Figure Meter
- Fixed IF or LO Frequency Selection
- Measurement Modes
- Noise Figure Test Set YIG Filter Calibration
- Sideband Selection
- Special Functions

Measurement Mode 1.8 (Special Function 1.8)

Description

Measurement Mode 1.8 is for DUTs with frequency conversion and a variable DUT LO. The measurement system expects a fixed IF at a frequency ranging from 10 MHz to 26.5 GHz. If the 1st IF can be reduced below 1600 MHz (2047 MHz, opt 020), then Measurement 1.3 is a better choice than Measurement 1.8. Since Measurement 1.3 requires less equipment, less noise figure is contributed by the measurement. The Typical DUT is mixer or receiver. All the Measurement Modes can be set up to use many of the other capabilities of the Noise Figure Meter. For example, each mode can make either UNCORRECTED NOISE FIGURE or CORRECTED NOISE FIGURE AND GAIN measurements, plus the measurement results for each mode can be displayed on an oscilloscope and output to a recorder or plotter.

NOTE

The Noise Figure Meter has limited control of the user controlled LO. However, in the following text the user controlled LO is not controlled by the Noise Figure Meter; the user must control the LO. Refer to the Comments section at the end of this instruction for an explanation of how to have the Noise Figure Meter control the LO.

Requirements

The following minimum requirements are necessary for the Noise Figure Measurement System and user controlled local oscillator to operate in Measurement Mode 1.8.

Measurement Mode 1.8 (cont'd) (Special Function 1.8)

Requirements (cont'd)

- a. The system local oscillator and the Noise Figure Test Set must be connected to the Noise Figure Meter's SYSTEM INTERFACE BUS connector with an HP-IB cable.
- b. Special Function 48.0 must be active (Noise Figure Meter is system controller on System Interface Bus; Special Function 48.0 is the default setting, after using Special Function 0.9).
- c. Special Function 45.0 must be active (Noise Figure Test Set enabled in measurement modes 1.5 through 1.9; Special Function 45.0 is the default setting, after using Special Function 0.9.) or Special Function 45.1 (Noise Figure Test Set enabled always) must be active.
- d. The address of the Noise Figure Test Set must match the Noise Figure Test Set address that is stored in the Noise Figure Meter. Use Special Function 40.2 (Noise Figure Test Set address) to display and change the address if necessary. The default address for the Noise Figure Test Set is 10, after using Special Function 0.9.
- e. Special Function 46.0 must be active (Enable system local oscillator on System Interface Bus; Special Function 46.0 is the default setting, after using Special Function 0.9.).
- f. The address of the system local oscillator must match the address of the system local oscillator stored in the Noise Figure Meter. Use Special Function 40.1 (system local oscillator System Interface Bus address) to display and change this address if necessary. The default address is 19, after using Special Function 0.9.
- g. The correct system local oscillator program must be active if the Noise Figure Meter is going to control the system local oscillator. The system local oscillator programs are listed below:
 - HP 8671B/8672A Synthesized Signal Generators; Special Function 41.2
 - HP 8673B/C/G (Standard) Synthesized Signal Generator; Special Function 41.3
 - HP 8340B/8341B Sweep Oscillator; Special Function 41.4
 - Custom local oscillator; Special Function 41.5

The custom local oscillator program will support local oscillators that may require a maximum of twenty-two characters for the frequency prefix and suffix and/or the output power prefix and suffix. The prefix and suffix define the command sequence that will set the frequency or output power.

Use Special Function 42 to define a new program for other system local oscillators.

- h. Configure the user controlled local oscillator to produce the desired frequency.

Procedure

There are many possible measurement procedures. However, the following general procedure applies to all cases:

NOTE

High measurement system noise figure leads to high measurement uncertainty, when measuring low gain devices. A low noise preamplifier, between the device under test and the measurement system, can lower

Measurement Mode 1.8 (cont'd)

(Special Function 1.8)

Procedure (cont'd)

system noise figure and therefore reduce the measurement uncertainty. For more information on determining if a preamplifier is needed and selection of the preamplifier, refer to Application Note 57-2.

- a. Verify that the minimum requirements specified under Requirements are satisfied.
- b. Press PRESET.
- c. Press 1.8 SPECIAL FUNCTION to set the Noise Figure Meter to Measurement Mode 1.8.
- d. Set frequency parameters (including the fixed IF, Special Function 3.0).
- e. Enter the ENR table for calibration (Special Function 5.7) and the ENR table for the measurement (Special Function 5.8). Refer to the ENR Table Entry Detailed Operating Instruction for more information.
- f. Select appropriate smoothing (Special Function 13).
- g. Select sideband operation desired. (Special Function 2 and 17)
- h. Perform a Noise Figure Test Set Fine Tuning Calibration. Refer to the Noise Figure Test Set YIG Calibration Detailed Operating Instruction for more information.
- i. With the device under test (DUT) removed, perform a calibration of the Noise Figure Measurement System in Mode 1.8 (this is only required for a CORRECTED NOISE FIGURE AND GAIN measurement). If a preamplifier is required for the measurement, the preamplifier must be used in the calibration.
- j. Insert DUT and measure the noise figure or noise figure and gain of the DUT.

Example

To make a swept CORRECTED NOISE FIGURE AND GAIN single sideband measurement in the 30 to 45 GHz range in 200 MHz steps with a fixed IF of 4000 MHz.

NOTE

This example assumes that the Noise Figure Meter is acting as a controller and the minimum requirements specified under Requirements are satisfied. Refer to Comments for a brief description of using an external controller when in Measurement Mode 1.8.

- a. Press PRESET (or send HP-IB code PR) to establish initial conditions. PRESET selects a single sideband measurement (Special Function 17.0) for the Noise Figure Test Set.

NOTE

Measurement Mode 1.8 must be activated prior to entering the frequency parameters to avoid error E35 (entered value is out of range).

- b. Press 1.8 SPECIAL FUNCTION to activate Measurement Mode 1.8.

Measurement Mode 1.8 (cont'd) (Special Function 1.8)

**Example
(cont'd)**

c. Set the frequency parameters for both the calibration and measurement.

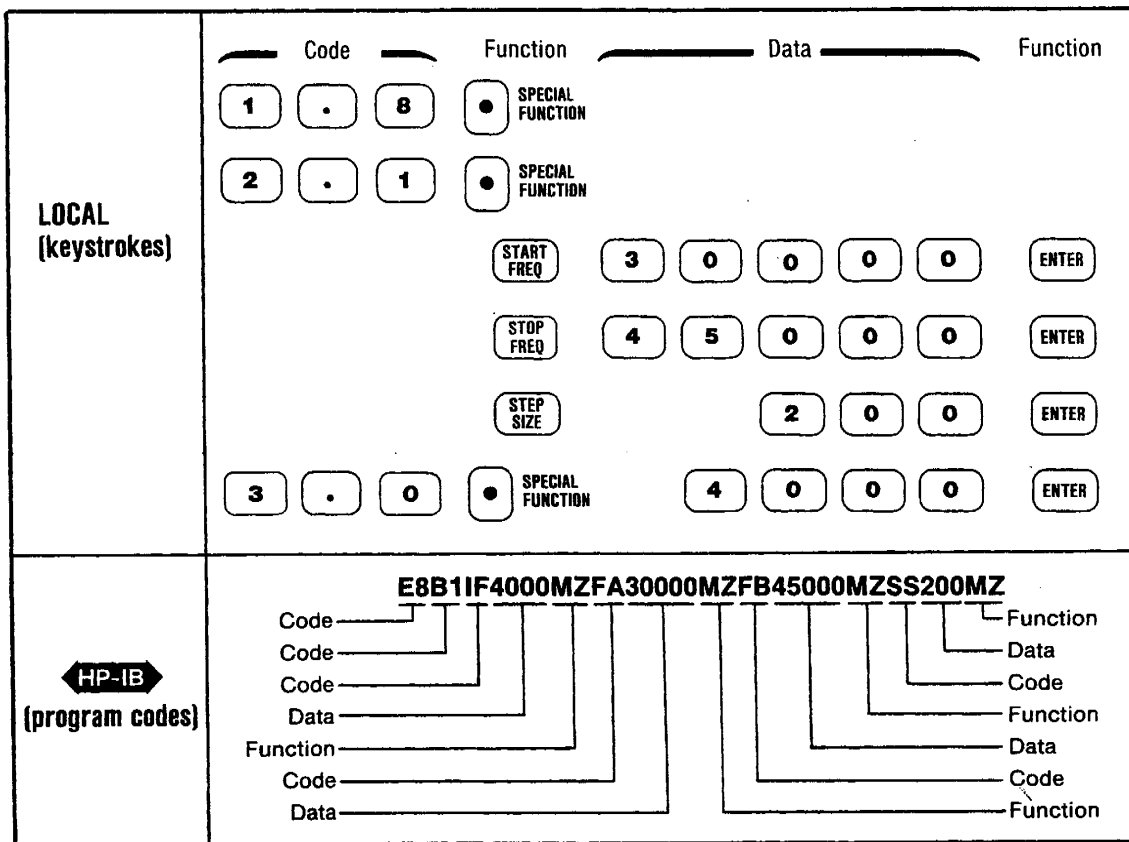

d. Enter the calibration and measurement ENR tables, if this hasn't already been done (Special Functions 5.7 and 5.8).

e. Press 2.1 SPECIAL FUNCTION to enable a lower sideband measurement. Special Function 2.1 is used with the first frequency conversion, using the user controlled local oscillator and the device under test.

NOTE

When a single sideband measurement is being made, the user must place a filter between the noise source and the device under test to eliminate the unwanted sideband.

f. Configure the user controlled local oscillator to produce a 4 GHz IF at the input of the Noise Figure Measurement System. The correct frequency to set the user controlled local oscillator to can be viewed by using Special Function 3.2.

Measurement Mode 1.8 (cont'd)

(Special Function 1.8)

Example (cont'd)

g. To calibrate the Noise Figure Measurement System and perform a Noise Figure Test Set Fine Tuning calibration, set up the equipment as shown below.

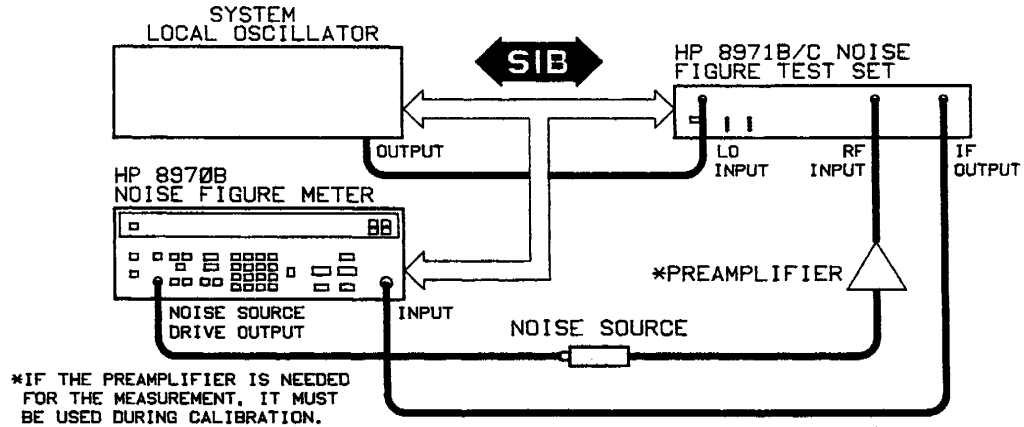

Figure 3-35. Measurement Mode 1.8 Calibration Setup

NOTES

For a single sideband measurement, the external filter is not included during calibration. During calibration the Noise Figure Meter only accounts for loss after the device under test. Since the filter is before the device under test, the loss of the filter is not accounted for properly.

To account for the filter's conversion loss, enter the filter's loss (in dB) into the Noise Figure Meter using Special Function 34.2 (loss between the noise source and device under test). Also, enter the room temperature of the filter using Special Function 34.3. To turn loss compensation on, use Special Function 34.1.

h. Calibrate and fine tune in Measurement Mode 1.8 by pressing the CALIBRATE key twice. PRESET enabled a fine tune (Special Function 36.0) to be done each time a calibration is done.

Measurement Mode 1.8 (cont'd) (Special Function 1.8)

**Example
(cont'd)**

i. To make the measurement, set up the equipment as shown below.

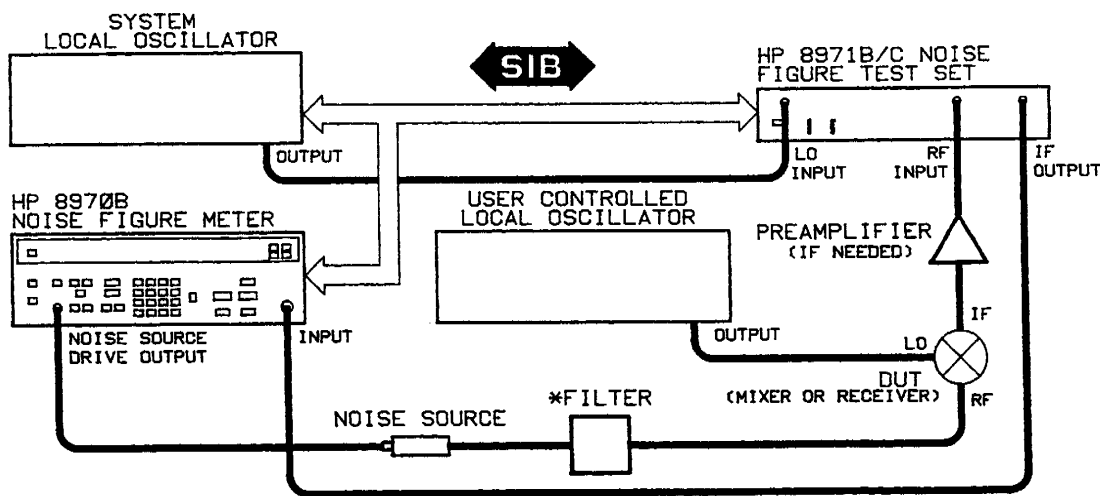

*THE FILTER IS ADDED IF A SINGLE SIDEBAND MEASUREMENT IS BEING MADE.

Figure 3-36. Measurement Mode 1.8 Setup

NOTE

For the Noise Figure Measurement System specifications to be valid, the measurement must use the same START FREQ, STOP FREQ and STEP SIZE that was used for calibration. None of the calibrated points can be skipped. Also, the measurement must be done in the same direction as the calibration, for example, from start frequency to stop frequency.

j. Press CORRECTED NOISE FIGURE AND GAIN.

k. While in trigger hold mode (Special Function 30.1), press SWEEP SINGLE. Sweep the user controlled local oscillator from 34000 MHz to 49000 MHz in 200 MHz steps and trigger a measurement at each frequency of interest.

Program Codes

HP-IB

The HP-IB code for Measurement Mode 1.8 is E8 (or 1.8SP). Refer to Comments for additional information on using HP-IB program codes in Measurement Mode 1.8.

Indications

The left display shows each frequency at which a measurement is made and the EXT MIX annunciator lights. The INSERTION GAIN display shows the gain of the DUT at the displayed frequency. The NOISE FIGURE display shows the noise figure of the DUT at the displayed frequency.

Comments

An external controller can be used to control the Noise Figure Measurement System and the user controlled local oscillator. The following general conditions must be observed when using an external controller:

- a. The external controller and the user controlled local oscillator must be connected to the Noise Figure Meter's HP-IB connector.
- b. HP-IB code H1 must be active.

Measurement Mode 1.8 (cont'd)

(Special Function 1.8)

Comments (cont'd)

- c. Special Function 4.0 (normal talker and listener) must be active. Note that there is no HP-IB code for this special function.
- d. Special Function 30.0 (free run) should be active (HP-IB code is T0).
- e. The correct measurement parameters (for example, Measurement Mode, frequencies, etc.) must be established. Refer to Table 3-9, Special Function to HP-IB Code Summary and Table 3-10, Front Panel Keys to HP-IB Code Summary, for applicable HP-IB codes.
- f. Perform a Noise Figure Test Set Fine Tuning Calibration and a Noise Figure Measurement System Calibration with the DUT out of the measurement system (refer to the Calibrate Detailed Operating Instruction and the Noise Figure Test Set YIG Filter Calibration Detailed Operating Instruction).
- g. Send the command "RM 2EN RS CA." Wait for a serial poll to return a non-zero value, indicating calibration is complete.
- h. Insert the DUT into the measurement system.
- i. Special Function 30.1 (trigger hold) must be active (HP-IB code is T1).
- j. Set the Noise Figure Meter's SINGLE sweep on (HP-IB code is W2) or AUTO sweep on (HP-IB code is W1).
- k. Set the user controlled LO to the desired frequency, depending on the sideband selection. If double sideband was selected, the oscillator should be set to the measurement frequency. If lower sideband was selected, the oscillator should be set to the measurement frequency plus the IF. If upper sideband was selected, the oscillator should be set to the measurement frequency minus the IF. If sum (upconversion; Special Function 2.3) was selected, set the oscillator to the IF minus the measurement frequency. Refer to the user controlled LO's operating manual for the required HP-IB codes. Allow sufficient time for the output of the user controlled LO to stabilize.
- l. Trigger a measurement using the HP-IB code T2. Do not use the alternate HP-IB code 30.2SP for Special Function 30.2 as it will reset the sweep.
- m. A method must be determined when to step to a new frequency after reading the noise figure results. This read operation cannot be completed until the new data is ready. It is possible to write an SRQ interrupt routine on the Data Ready Status Bit. Refer to Enabling the Service Request Condition, paragraph 3-30.
- n. Continue to loop through steps k, l and m. A method for determining when the measurements are complete must be programmed into the external controller. One method is to compare the measurement frequency that is read from the Noise Figure Meter with the stop frequency programmed into the Noise Figure Meter and terminate the program after the measurement in which they are equal.

User Controlled Local Oscillator Control

The Noise Figure Meter can control the user controlled LO to a limited extent. If the system LO and the user controlled LO are to be controlled by the same predefined program (Special Function 41), control is limited to setting the frequency prefix and suffix (Special Function 42.1). The frequency prefix and suffix are used to properly format the command sequence that will set the LO's output frequency. If the user

Measurement Mode 1.8 (cont'd)

(Special Function 1.8)

Comments (cont'd)

controlled LO is to be controlled by the custom LO program (Special Function 41.5) and the system LO is controlled by another predefined program, the Noise Figure Meter has increased control of the user controlled LO. The additional control can include setting the output power level and turning off any modulation. The Noise Figure Meter will not check to see if an out of range frequency has been sent to the user controlled LO. Also, a variable settling time is not allowed. A default settling time of 200 ms is always used.

Add the following steps to the Requirements section at the beginning of the measurement instruction:

NOTE

Any steps within the measurement instruction that say to set the user controlled LO manually may be ignored. Where the user controlled LO was set manually the Noise Figure Meter will set the LO.

a. The user controlled LO must be connected to the Noise Figure Meter's SYSTEM INTERFACE BUS.

b. Special Function 96.1 must be active (Enable the user controlled LO on the System Interface bus).

c. The address of the user controlled LO must match the address of the user controlled LO stored in the Noise Figure Meter. Use Special Function 96.2 (user controlled LO System Interface Bus address) to display and change this address if necessary. The default address is 20, after using Special Function 0.9.

NOTE

If Special Function 96.1 is active (enable the user controlled LO) and the Noise Figure Meter can't find the LO at the address set by Special Function 96.2, error code E106 will be displayed.

d. Special Function 96.3 must be used to let the Noise Figure Meter know if the system LO and the user controlled LO are using the same predefined program (Special Function 41). Or, if the user controlled LO will be controlled by the custom LO program (Special Function 41.5). If the two LOs are being controlled by the same predefined program, zero is entered after Special Function 96.3 is enabled. If the user controlled LO is being controlled by the custom LO program, one is entered after Special Function 96.3 is enabled. The procedure is to key in 96.3, press SPECIAL FUNCTION, key in 0 or 1 and press ENTER.

If the system LO and the user controlled LO are to be controlled by the same program, the Noise Figure Meter has limited control of the user controlled LO. Control is limited to setting the frequency prefix and suffix. All other commands must be set manually.

If the user controlled LO is to be controlled by the custom LO program and the system LO is controlled by another predefined program, the Noise Figure Meter has increased control of the user controlled LO. The increased control can include setting the power level and other commands. When the custom LO program is used, only the frequency prefix and suffix section (Special Function 42.7) is valid. All commands are set using Special Function 42.7. The frequency prefix and suffix can have a total of twenty-two characters. Plus there are two characters (count characters) that are used to indicate the number of characters in the prefix and in the suffix. Since the maximum number of

Measurement Mode 1.8 (cont'd) (Special Function 1.8)

**Comments
(cont'd)**

characters in the prefix and suffix is twenty-two, the frequency prefix and suffix determines the number of additional commands that can be added. The output power level and any other commands are placed in the frequency suffix.

The following procedure outlines the steps needed to setup the custom LO program to control the user controlled LO:

NOTE

When the user controlled LO is controlled by the custom LO program, Special Function 41.5 is NOT enabled. If Special Function 41.5 were to be enabled, the predefined program controlling the system LO would be replaced by the custom LO program. This would be an undesirable condition. Control of the user controlled LO is accomplished using Special Function 42.7. With Special Function 96.3 set to 1, the frequency prefix and suffix defined by Special Function 42.7 will be used, without having Special Function 41.5 active.

1. Special Function 42.7 must be active (frequency prefix and suffix). This allows modification of the frequency prefix and suffix.
2. Modify the frequency prefix by entering the decimal count for the number of characters in the prefix followed by the decimal equivalents of the required ASCII prefix characters. Then, enter the decimal count for the number of suffix characters followed by the decimal equivalents of the ASCII suffix characters. With Special Function 42.7 active, the decimal values are entered using the front panel key pad. Each time a decimal is keyed in, the ENTER key is pressed. For additional information refer to the Programming The System LO Detailed Operating Instruction (Example 2, Using the Custom Local Oscillator Program).

For example, the desired characters could be as follows:

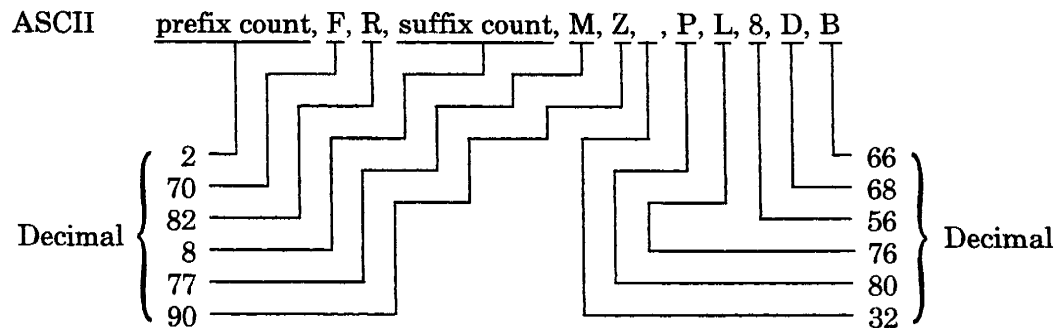

Where 2 is the number of characters in the prefix. "FR" (decimal 70 and 82) is the frequency prefix. 8 is the number of characters in the suffix. "MZ" (decimal 77 and 90) is the frequency suffix followed by a space (decimal 32). "PL" (decimal 80 and 76) is the power prefix. 8 (decimal 56) is the power level. "DB" (decimal 68 and 66) is the power suffix.

A space can be used between each command set. As the example shows a space was placed between the frequency prefix and suffix and the power setting command.

Measurement Mode 1.8 (cont'd)

(Special Function 1.8)

Comments (cont'd)

In the example ten characters were used. Since twenty-two characters can be used between the frequency prefix and suffix, twelve more characters could be added to the suffix to control other functions.

- e. Pressing the FREQUENCY key will exit the user from Special Function 42.7.

Related Sections

Calibrate
Controller Capability of the Noise Figure Meter
Fixed IF or LO Frequency Selection
HP-IB Addresses
Noise Figure Test Set YIG Filter Calibration
Sideband Selection
Special Functions
System Interface Bus Control
Trigger Selection

3-182.4 This Page Intentionally Left Blank

Measurement Mode 1.9 (Special Function 1.9)

Description

Measurement mode 1.9 is for DUTs with frequency conversion and a fixed DUT LO with a wideband DUT IF frequencies <26.5 GHz. The measurement system uses the HP 8971C and its variable LO to convert the wideband DUT IFs (ranging from 10MHz to 26.5 GHz) into the range of the HP 8970B Option 020. A typical DUT is a microwave or millimeter wave block down converter. The measurement system's IF is variable and the measurement frequency entered and displayed on the Noise Figure Meter is the swept IF START, STOP and STEP frequencies. Although the frequency entered on the Noise Figure Meter corresponds to the DUT IF, (10 MHz to 26500 MHz), the Noise Figure Meter uses the excess noise ratio, ENR, of the noise source at the DUT input frequency. All the Measurement Modes can be set up to use many of the other capabilities of the Noise Figure Meter. For example, each mode can make either UNCORRECTED NOISE FIGURE or CORRECTED NOISE FIGURE AND GAIN measurements, plus the measurement results for each mode can be displayed on an oscilloscope and output to a recorder or plotter.

NOTE

The Noise Figure Meter has limited control of the user controlled LO. However, in the following text the user controlled LO is not controlled by the Noise Figure Meter; the user must control the LO. Refer to the Comments section at the end of this instruction for an explanation of how to have the Noise Figure Meter control the LO.

Requirements

The following minimum requirements are necessary for the Noise Figure Measurement System and user controlled local oscillator to operate in Measurement Mode 1.9.

- a. The system local oscillator and the Noise Figure Test Set must be connected to the Noise Figure Meter's SYSTEM INTERFACE BUS connector with an HP-IB cable.
- b. Special Function 48.0 must be active (Noise Figure Meter is system controller on System Interface Bus; Special Function 48.0 is the default setting, after using Special Function 0.9.).

Measurement Mode 1.9 (cont'd)

(Special Function 1.9)

Requirements (cont'd)

c. Special Function 45.0 must be active (Noise Figure Test Set enabled in measurement modes 1.5 through 1.9; Special Function 45.0 is the default setting, after using Special Function 0.9.) or Special Function 45.1 (Noise Figure Test Set enabled always) must be active.

d. The address of the Noise Figure Test Set must match the Noise Figure Test Set address that is stored in the Noise Figure Meter. Use Special Function 40.2 (Noise Figure Test Set System Interface Bus address) to display and change this address if necessary. The default address for the Noise Figure Test Set is 10, after using Special Function 0.9.

e. Special Function 46.0 must be active (Enable system local oscillator on System Interface Bus; Special Function 46.0 is the default setting, after using Special Function 0.9.).

f. The address of the system local oscillator must match the address of the system local oscillator stored in the Noise Figure Meter. Use Special Function 40.1 (system local oscillator System Interface Bus address) to display and change this address if necessary. The default address is 19, after using Special Function 0.9.

g. The correct system local oscillator program must be active if the Noise Figure Meter is going to control the system local oscillator. The system local oscillator programs are listed below:

- HP 8671B/8672A Synthesized Signal Generator; Special Function 41.2
- HP 8673B/C/G (Standard) Synthesized Signal Generator; Special Function 41.3
- HP 8340B/8341B Sweep Oscillator; Special Function 41.4
- Custom local oscillator; Special Function 41.5

The custom local oscillator program will support local oscillators that may require a maximum of twenty-two characters for the frequency prefix and suffix and/or the output power prefix and suffix. The prefix and suffix define the command sequence that will set the frequency or output power.

Use Special Function 42 to define a new program for other system local oscillators.

h. The user controlled local oscillator must be configured to produce the desired IF (10 to 26500 MHz).

Procedure

There are many possible measurement procedures. However, the following general procedure applies to all cases:

NOTE

High measurement system noise figure leads to high measurement uncertainty, when measuring low gain devices. A low noise preamplifier, between the device under test and the measurement system, can lower system noise figure and therefore reduce the measurement uncertainty. For more information on determining if a preamplifier is needed and selection of the preamplifier, refer to Application Note 57-2.

Measurement Mode 1.9 (cont'd)

(Special Function 1.9)

Procedure (cont'd)

- a. Verify that the minimum requirements specified under Requirements are satisfied.
- b. Press PRESET.
- c. Press 1.9 SPECIAL FUNCTION to set the Noise Figure Meter to Measurement Mode 1.9.
 - d. Set the frequency parameters. The frequency parameters include the frequency of the system LO or DUT LO (Special Function 3.1); and the sideband selection (Special Functions 2.0, 2.1 or 2.2 for double, lower or upper sideband). Note that the START, STOP and STEP frequencies refer to the IF frequencies. Special Functions 3.1 and 2.1 or 2.2 must be used, even if the DUT's LO isn't on the SYSTEM INTERFACE BUS so Noise Figure Meter will be able to correctly determine the DUT's input frequency and, therefore, choose the appropriate ENR. If the DUT has its own internal LO then disable the User Controlled LO on the SYSTEM INTERFACE BUS (Special Function 96.0).
 - e. Enter ENR tables for calibration and measurement (use Special Functions 5.7 and 5.8).
 - f. Select sideband operation desired (Special Function 2 and 17).
 - g. Set up the user controlled local oscillator to produce the desired output, as specified by Special Function 3.1.
 - h. Perform a Noise Figure Test Set Fine Tuning Calibration. For more information, refer to the Noise Figure Test Set YIG Filter Calibration Detailed Operating Instruction.
 - i. Calibrate the Noise Figure Measurement System in Mode 1.9 (this is only required for a CORRECTED NOISE FIGURE AND GAIN measurement). If a preamplifier is required for the measurement, the preamplifier must be used in the calibration.
 - j. Insert DUT into the measurement system and make a noise figure or noise figure and gain measurement.

Example

NOTE

The following example assumes that the Noise Figure Meter is the controller. An external controller can be used to control the Noise Figure Measurement System and the user controlled local oscillator. For more information on using an external controller, refer to Comments at the end of this instruction.

To make a swept CORRECTED NOISE FIGURE AND GAIN single sideband measurement over an IF of 10 to 12 GHz using 100 MHz steps with a fixed user controlled local oscillator frequency of 5 GHz.

- a. Press PRESET (or send HP-IB code PR) to establish initial conditions. PRESET selects a single sideband measurement (Special Function 17.0) for the Noise Figure Test Set.

NOTE

Measurement Mode 1.9 must be activated prior to entering the frequency parameters to avoid error E35 (entered value is out of range).

- b. Press 1.9 SPECIAL FUNCTION (or send HP-IB code E9) to activate Measurement Mode 1.9.

Measurement Mode 1.9 (cont'd) (Special Function 1.9)

**Example
(cont'd)**

c. Set the frequency parameters for both the calibration and measurement.

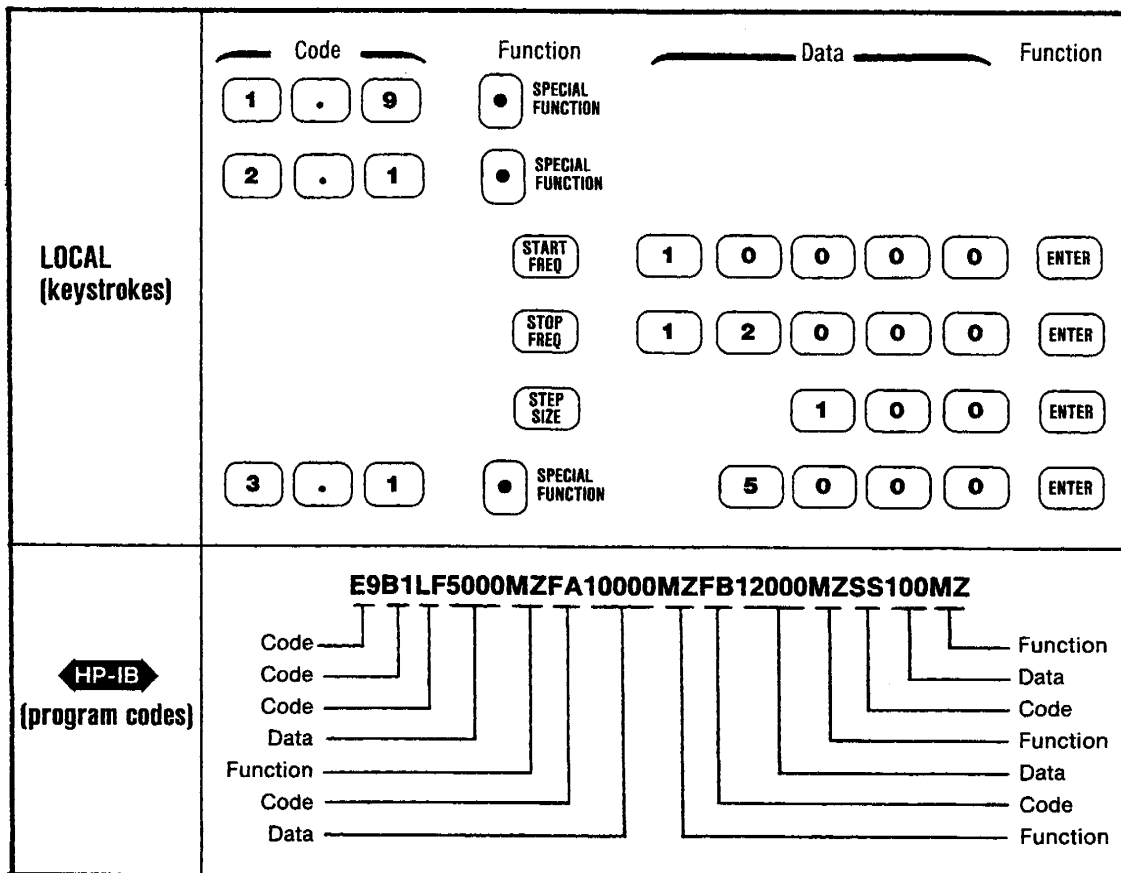

d. Enter the ENR tables for calibration (Special Function 5.7) and the measurement (Special Function 5.8), if this hasn't already been done. Refer to the ENR Table Entry Detailed Operating Instruction for more information.

e. Press 2.1 SPECIAL FUNCTION to select a lower sideband measurement. Special Function 2.1 is used to select the sideband operation desired for the first frequency conversion, using the user controlled local oscillator and the device under test.

NOTE

When a signal sideband measurement is being made, the user must place a filter between the noise source and the device under test to eliminate the unwanted sideband, if the DUT doesn't already have one prior to its first convertor.

f. To calibrate the Noise Figure Measurement System and perform a Noise Figure Test Set Fine Tuning Calibration, set up the equipment as shown below.

Measurement Mode 1.9 (cont'd)

(Special Function 1.9)

**Example
(cont'd)**

NOTES

For a single sideband measurement, the external filter is not included during calibration. During calibration the Noise Figure Meter only accounts for loss after the device under test.

To account for the filter's conversion loss during measurement, enter the filter's loss (in dB) into the Noise Figure Meter using Special Function 34.2 (loss between the noise source and device under test). Also, enter the temperature of the filter using Special Function 34.3. To turn loss compensation on, use Special Function 34.1.

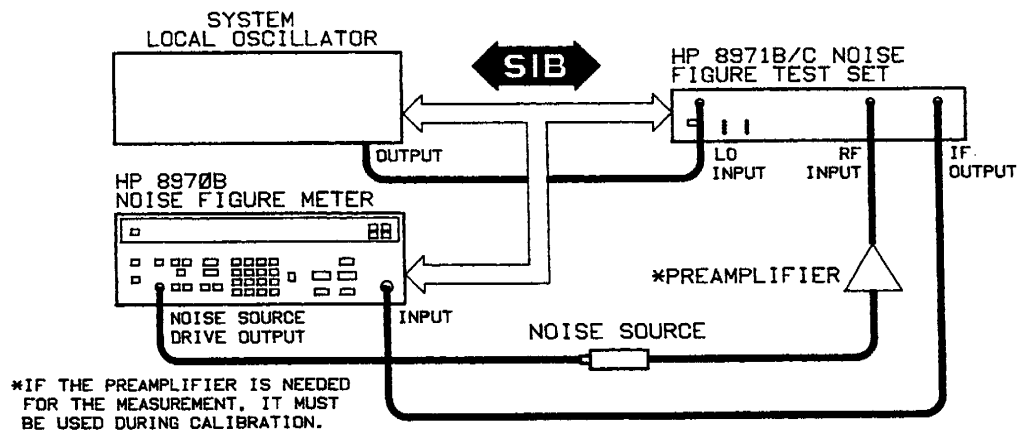

Figure 3-37. Measurement Mode 1.9 Calibration Setup

g. Calibrate the Noise Figure Measurement System and fine tune the Noise Figure Test Set in Mode 1.9 by pressing CALIBRATE twice (or sending HP-IB code CA). PRESET enabled a fine tuning calibration (Special Function 36.0) each time the Noise Figure Measurement system is calibrated.

h. To make the measurement, set up the equipment as shown below.

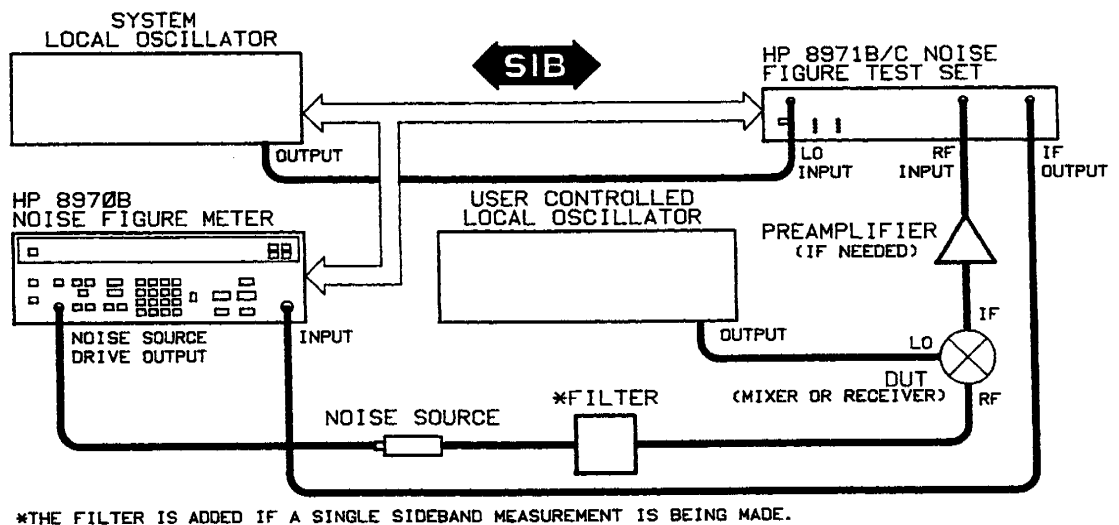

Figure 3-38. Measurement Mode 1.9 Setup

Measurement Mode 1.9 (cont'd)

(Special Function 1.9)

Example (cont'd)

NOTE

For the Noise Figure Measurement System specifications to be valid, the measurement must use the same START FREQ, STOP FREQ and STEP SIZE that was used for calibration. None of the calibrated points can be skipped. Also, the measurement must be done in the same direction as the calibration, for example, from start frequency to stop frequency.

This example assumes that the user controlled local oscillator is tuned to the specified frequency (5 GHz).

i. Press CORRECTED NOISE FIGURE AND GAIN (or send HP-IB code M2).

j. Press SINGLE (or send HP-IB code W2). The Noise Figure Measurement System will sweep from 10 to 12 GHz in 100 MHz steps. After the single sweep is completed, the system halts.

Program Codes

The HP-IB code for Measurement Mode 1.9 is E9 (or 1.9SP). The Comments section contains additional HP-IB codes, when using an external controller.

HP-IB

Indications

The left display shows each IF frequency at which a measurement is made and the EXT MIX annunciator lights. The INSERTION GAIN display shows the gain of the DUT at the displayed frequency. The NOISE FIGURE display shows the noise figure of the DUT at the displayed frequency.

Comments

An external controller can be used to control the Noise Figure Measurement System and the user controlled local oscillator in Measurement Mode 1.9. The following general conditions must be observed when using an external controller:

a. The external controller and the user controlled local oscillator must be connected to the HP-IB connector on the Noise Figure Meter.

b. HP-IB code H1 must be active.

c. Special Function 4.0 (normal talker and listener) must be active. Note that there is no HP-IB code for this special function.

d. Special Function 30.0 (free run) should be active (HP-IB code is T0).

e. The correct measurement parameters (for example, Measurement Mode, frequencies, etc.) must be established. Refer to Table 3-9, Special Function to HP-IB Code Summary, and Table 3-10, Front Panel Keys to HP-IB Code Summary, for applicable HP-IB codes.

f. Set the user controlled local oscillator to the appropriate frequency. Refer to the local oscillator's operating manual for the required HP-IB codes. Allow sufficient time for the output of the local oscillator to stabilize.

g. Perform a Noise Figure Test Set Fine Tuning Calibration and a Noise Figure Measurement System Calibration with the DUT out of the measurement system (refer to the Calibrate Detailed Operating Instruction and the Noise Figure Test Set YIG Filter Calibration Detailed Operating Instruction).

Measurement Mode 1.9 (cont'd)

(Special Function 1.9)

Comments (cont'd)

- h. Send the command "RM 2EN RS CA." Wait for a serial poll to return a non-zero value, indicating calibration is complete.
- i. Insert the DUT into the measurement system.
- j. Special Function 30.1 (trigger hold) must be active (HP-IB code is T1).
- k. Set the Noise Figure Meter's SINGLE sweep on (HP-IB code is W2) or AUTO sweep on (HP-IB code is W1).
- l. Trigger a measurement using the HP-IB code T2. Do not use the alternate HP-IB code 30.2SP for Special Function 30.2 as it will reset the sweep.
- m. A method must be determined when to step to a new frequency after reading the noise figure results. This read operation cannot be completed until the new data is ready. It is possible to write an SRQ interrupt routine on the Data Ready Status Bit. Refer to Enabling the Service Request Condition, paragraph 3-30.
- n. Continue to loop through steps l and m. A method for determining when the measurements are complete must be programmed into the external controller. One method is to compare the measurement frequency that is read from the Noise Figure Meter with the stop frequency programmed into the Noise Figure Meter and terminate the program after the measurement in which they are equal.

User Controlled Local Oscillator Control

The Noise Figure Meter can control the user controlled LO to a limited extent. If the system LO and the user controlled LO are to be controlled by the same predefined program (Special Function 41), control is limited to setting the frequency prefix and suffix (Special Function 42.1). The frequency prefix and suffix are used to properly format the command sequence that will set the LO's output frequency. If the user controlled LO is to be controlled by the custom LO program (Special Function 41.5) and the system LO is controlled by another predefined program, the Noise Figure Meter has increased control of the user controlled LO. The additional control can include setting the output power level and turning off any modulation. The Noise Figure Meter will not check to see if an out of range frequency has been sent to the user controlled LO. Also, a variable settling time is not allowed. A default settling time of 200 ms is always used.

Add the following steps to the Requirements section at the beginning of the measurement instruction:

NOTE

Any steps within the measurement instruction that say to set the user controlled LO manually may be ignored. Where the user controlled LO was set manually the Noise Figure Meter will set the LO.

- a. The user controlled LO must be connected to the Noise Figure Meter's SYSTEM INTERFACE BUS.
- b. Special Function 96.1 must be active (Enable the user controlled LO on the System Interface bus).
- c. The address of the user controlled LO must match the address of the user controlled LO stored in the Noise Figure Meter. Use Special Function 96.2 (user controlled LO System Interface Bus address) to display and change this address if necessary. The default address is 20, after using Special Function 0.9.

Measurement Mode 1.9 (cont'd)

(Special Function 1.9)

Comments (cont'd)

NOTE

If Special Function 96.1 is active (enable the user controlled LO) and the Noise Figure Meter can't find the LO at the address set by Special Function 96.2, error code E106 will be displayed.

d. Special Function 96.3 must be used to let the Noise Figure Meter know if the system LO and the user controlled LO are using the same predefined program (Special Function 41). Or, if the user controlled LO will be controlled by the custom LO program (Special Function 41.5). If the two LOs are being controlled by the same predefined program, zero is entered after Special Function 96.3 is enabled. If the user controlled LO is being controlled by the custom LO program, one is entered after Special Function 96.3 is enabled. The procedure is to key in 96.3, press SPECIAL FUNCTION, key in 0 or 1 and press ENTER.

If the system LO and the user controlled LO are to be controlled by the same program, the Noise Figure Meter has limited control of the user controlled LO. Control is limited to setting the frequency prefix and suffix. All other commands must be set manually.

If the user controlled LO is to be controlled by the custom LO program and the system LO is controlled by another predefined program, the Noise Figure Meter has increased control of the user controlled LO. The increased control can include setting the power level and other commands. When the custom LO program is used, only the frequency prefix and suffix section (Special Function 42.7) is valid. All commands are set using Special Function 42.7. The frequency prefix and suffix can have a total of twenty-two characters. Plus there are two characters (count characters) that are used to indicate the number of characters in the prefix and in the suffix. Since the maximum number of characters in the prefix and suffix is twenty-two, the frequency prefix and suffix determines the number of additional commands that can be added. The output power level and any other commands are placed in the frequency suffix.

The following procedure outlines the steps needed to setup the custom LO program to control the user controlled LO:

NOTE

When the user controlled LO is controlled by the custom LO program, Special Function 41.5 is NOT enabled. If Special Function 41.5 were to be enabled, the predefined program controlling the system LO would be replaced by the custom LO program. This would be an undesirable condition. Control of the user controlled LO is accomplished using Special Function 42.7. With Special Function 96.3 set to 1, the frequency prefix and suffix defined by Special Function 42.7 will be used, without having Special Function 41.5 active.

1. Special Function 42.7 must be active (frequency prefix and suffix). This allows modification of the frequency prefix and suffix.
2. Modify the frequency prefix by entering the decimal count for the number of characters in the prefix followed by the decimal equivalents of the required ASCII prefix characters. Then, enter the decimal count for the number of suffix characters followed by the decimal equivalents of the ASCII suffix characters. With Special Function 42.7 active, the decimal values are entered using the front panel key pad.

Measurement Mode 1.9 (cont'd) (Special Function 1.9)

**Comments
(cont'd)**

Each time a decimal is keyed in, the ENTER key is pressed. For additional information refer to the Programming The System LO Detailed Operating Instruction (Example 2, Using the Custom Local Oscillator Program).

For example, the desired characters could be as follows:

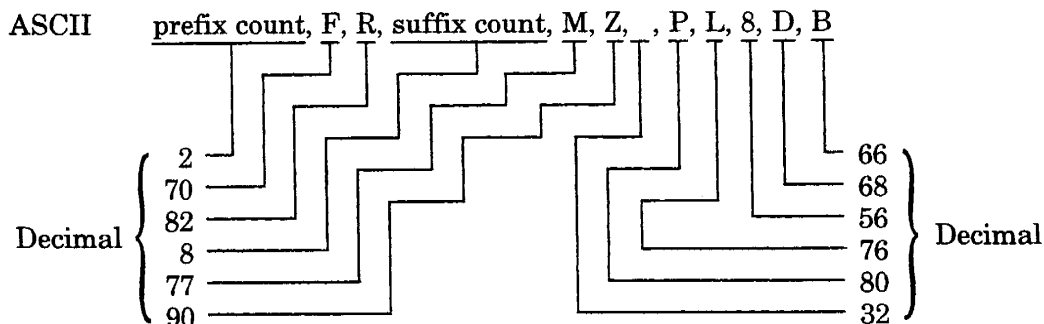

Where 2 is the number of characters in the prefix. "FR" (decimal 70 and 82) is the frequency prefix. 8 is the number of characters in the suffix. "MZ" (decimal 77 and 90) is the frequency suffix followed by a space (decimal 32). "PL" (decimal 80 and 76) is the power prefix. 8 (decimal 56) is the power level. "DB" (decimal 68 and 66) is the power suffix.

A space can be used between each command set. As the example shows a space was placed between the frequency prefix and suffix and the power setting command.

In the example ten characters were used. Since twenty-two characters can be used between the frequency prefix and suffix, twelve more characters could be added to the suffix to control other functions.

- e. Pressing the FREQUENCY key will exit the user from Special Function 42.7.

**Related
Sections**

- Calibrate
- Controller Capability of the Noise Figure Meter
- ENR Table Entry
- Fixed IF or LO Frequency Selection
- Noise Figure Test Set YIG Filter Calibration
- Sideband Selection
- Special Functions
- System Interface Bus Control

Noise Figure Test Set YIG Filter Calibration (Special Functions 36 and 64)

Description

When the Noise Figure Meter, Noise Figure Test Set and system local oscillator are configured to form the Noise Figure Measurement System, the passbands of the Noise Figure Meter and the Noise Figure Test Set must be aligned.

The alignment process involves a Coarse Tuning Calibration (Special Function 64) and a Fine Tuning Calibration (Special Function 36).

Coarse Tuning Calibration (Special Function 64). The Coarse Tuning Calibration will be done at the factory and needs to be done when repairs are done to the Noise Figure Test Set.

NOTE

Sweepers are not recommended as the system local oscillator when the Noise Figure Test Set is operating in band SSB3. High local oscillator accuracy is needed by the Noise Figure Measurement System in this band. A better choice is a local oscillator that is a synthesizer.

The Coarse Tuning Calibration will align the passbands of the Noise Figure Meter and Noise Figure Test Set at the following frequencies: 2401 MHz, 3000 MHz, and every 500 MHz from 3500 MHz to 26500 MHz. At each of these frequencies, the Noise Figure Test Set preselector YIG filter is peaked at the frequency being calibrated. The entire calibration procedure will take about 15 minutes. The Coarse Tuning Calibration is not needed each time the Noise Figure Measurement System is powered up. Normally, the Coarse Tuning Calibration will only need to be done once or twice in the lifetime of a Noise Figure Test Set. The results of the Coarse Tuning Calibration will be saved in memory, in the Noise Figure Test Set.

NOTE

There is a limit to the number of Coarse Calibrations that can be performed. Due to the nature of the memory devices in the Noise Figure Test Set, the number of calibrations is limited to 10000.

Special Function 64.0 is used to enable a Coarse Tuning Calibration. The upper frequency limit of the Noise Figure Test Set can be changed using Special Function 64.1. The allowable range for Special Function 64.1 is 2400 to 30000 MHz. Special Function 64.1 is useful if the system local oscillator doesn't go to 26500 MHz. With Special Function 64.1, the Noise Figure Test Set can be calibrated to the nearest 500 MHz of the upper frequency limit desired.

NOTE

If the system local oscillator doesn't go to 26500 MHz, Special Function 64.1 MUST be used. If Special Function 64.1 isn't used, error code E19 (Noise Figure Test Set Calibration Failed) will be generated.

Fine Tuning Calibration (Special Function 36). Fine tuning calibration is used to align the passbands of the Noise Figure Meter and Noise Figure Test Set, at the measurement frequencies defined by START FREQ, STOP FREQ and STEP SIZE. Fine Tuning Calibration is required when the Noise Figure Test Set is in single sideband operation (Special Function 17.0) and the measurement frequency is greater than 2400 MHz (SSB3). There is no limit to the number of times that a Fine Tuning Calibration may be

Noise Figure Test Set YIG Filter Calibration (cont'd)

(Special Functions 36 and 64)

Description (cont'd)

performed. The Noise Figure Measurement System will perform better the more frequently a Fine Tuning Calibration is done. However, once the Fine Tuning Calibration is done, a new Fine Tuning Calibration should not be required unless the Noise Figure Test Set is turned off, the ambient air temperature around the Noise Figure Test Set changes by more than $\pm 5^{\circ}\text{C}$ since the last Fine Tuning Calibration or the START FREQ, STOP FREQ or STEP SIZE have been changed.

Fine Tuning Calibration is controlled by Special Functions 36.0 through 36.4.

The progress of the Coarse and Fine Tuning Calibrations may be viewed on an analog oscilloscope, using Special Functions 97.1 and 97.2. These special functions can be used to diagnose any measurement system setup problems. Special Functions 97.1 and 97.2 are described in the Example section of this instruction. Refer to Viewing a Coarse or Fine Tuning Calibration on an Oscilloscope.

The following discussion will help to give a better understanding of Special Functions 36.0 through 36.4, 64.0 and 64.1:

Special Function 36.0 will enable a Fine Tuning Calibration to be done just before the Noise Figure Measurement System is calibrated, when a CORRECTED NOISE FIGURE AND GAIN measurement is to be made. Also, error twenty-eight (E28) is enabled. Possible causes for error twenty-eight are given in the Comments section, at the end of this instruction. Error twenty-eight (E28) is a warning to the user and is not necessarily an indication of any hardware problem.

Special Function 36.1 will disable a Fine Tuning Calibration each time the Noise Figure Measurement System is calibrated. The user can perform a Fine Tuning Calibration using Special Function 36.3.

Special Function 36.2 disables a Fine Tuning Calibration each time the Noise Figure Measurement System is calibrated and also disables the error twenty-eight warning. The user can perform a Fine Tuning Calibration using Special Function 36.3. This special function is useful if the user is not concerned with absolute accuracy and understands the accuracy problems associated with not having the Noise Figure Test Set fine tuned. Possible causes of error twenty-eight are found in the Comments section at the end of this instruction. Even though the error is not displayed, a warning indication still exists in the Noise Figure Meter's extended status byte. Normally, using special function 36.2 is not a good idea because it removes the safeguard of the Noise Figure Measurement System checking to see if a Fine Tune Calibration is needed.

Special Function 36.3 will perform a Fine Tuning Calibration of the Noise Figure Test Set, immediately. Special Function 36.1 is enabled, since the Fine Tuning Calibration has been completed using Special Function 36.3. Additional Fine Tuning Calibrations are not needed unless the temperature inside the Noise Figure Test Set drifts five degrees centigrade or new frequency points are to be measured.

Special Function 36.4 allows the user to define additional Fine Tuning Calibration frequencies, between the frequencies set by START FREQ, STOP FREQ and STEP SIZE. The passbands are aligned for the frequency point added by Special Function 36.4, but the point added is not a calibrated point of the Noise Figure Measurement System. In other words, any noise contributed by the Noise Figure Measurement System has not been factored out at the frequency point added. Special Function 36.4 may be useful for an uncorrected noise figure measurement or as a way of re-fine tuning a single frequency point.

Noise Figure Test Set YIG Filter Calibration (cont'd)

(Special Functions 36 and 64)

Procedure

To select Special Functions 36.0 through 36.3 and 64.0, key in the special function code desired and press the SPECIAL FUNCTION key. To select Special Function 64.1, press 64.1 SPECIAL FUNCTION, select the frequency desired and press ENTER. To use Special Function 36.4, press the FREQUENCY key and select the frequency desired. Press ENTER. Then, press 36.4 SPECIAL FUNCTION.

Special Function		Program Code HP-IB	Lights Special ¹ Function Key	Stored in Con- tinuous Memory	Can be Stored and Recalled	Special Function 0.0 Conditions	Preset (and HP-IB Clear) Conditions	Special Function 0.9 Conditions
Description	Code							
Enable Fine Tuning Calibration before Noise Figure Measurement System Calibration is done. Error E28 is enabled.	36.0	FT	N	Y	Y	On	On	On
Disable Fine Tuning Calibration before Noise Figure Measurement System Calibration is done.	36.1	FD	N	Y	Y	Off	Off	Off
Disable Fine Tuning Calibration before Noise Figure Measurement System Calibration is done. Also, error twenty-eight is disabled.	36.2	FW	Y	Y	Y	Off	Off	Off
Perform a Fine Tuning Calibration from START FREQ to STOP FREQ and enable Special Function 36.1.	36.3	PF	N	N	N	Off	Off	Off
Enable a Fine Tuning Calibration at the current frequency.	36.4	FF	N	N	N	Off	Off	Off
Enable a Coarse Tuning Calibration.	64.0	CP	N	N	N	Off	Off	Off
Set the upper frequency limit of the Noise Figure Test Set.	64.1	CU	N	N	N	NC	26500	26500

¹Table categories are explained in the Special Functions Detailed Operating Instruction.

Noise Figure Test Set YIG Filter Calibration (cont'd)

(Special Functions 36 and 64)

Example

To select a coarse tuning calibration:

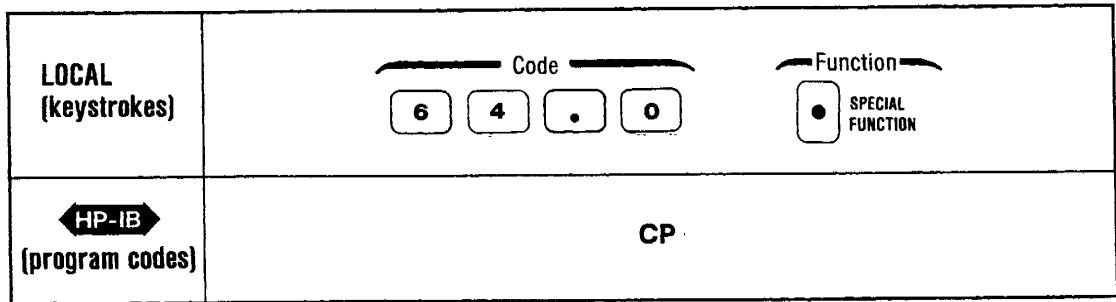

The following examples will describe how to perform a Coarse Tuning Calibration, Fine Tuning Calibration and how to view a Coarse or Fine Tuning Calibration on an oscilloscope.

Coarse Tuning Calibration. The following discussion will describe how to perform a Coarse Tuning Calibration:

NOTE

A Coarse Tuning Calibration should only be done when the Noise Figure Measurement System is first configured and a freerunning source is being used as the system local oscillator or repairs have been made to the Noise Figure Test Set.

The Excess Noise Ratio (ENR) of the noise source should be 12 to 13 dB or more from 2401 to 26500 MHz or a preamplifier may be required.

- a. Connect the equipment as shown below.

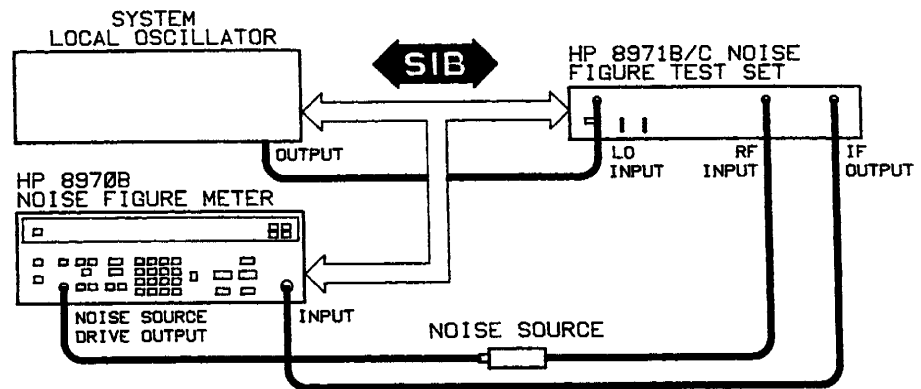

Figure 3-39. YIG Filter Calibration Setup

- b. Turn the equipment on and allow a twenty (20) minute warm up period, before performing the Coarse Tuning Calibration.

- c. If the upper frequency limit of the Noise Figure Test Set is to be less than 26500 MHz, enter the upper limit using Special Function 64.1.

Noise Figure Test Set YIG Filter Calibration (cont'd)

(Special Functions 36 and 64)

Example (cont'd)

d. After the equipment has warmed up for twenty minutes, press 64.0 SPECIAL FUNCTION. The Coarse Tuning Calibration will take about fifteen (15) minutes.

NOTE

If data is read from the Noise Figure Meter, over the Hewlett-Packard Interface Bus, during a Coarse Tuning Calibration, the Noise Figure Meter will output a special HP-IB code for the NOISE FIGURE window. For more information on this HP-IB code, refer to the Error Messages and Recovery Detailed Operating Instruction.

e. To view the Coarse Tuning Calibration, refer to Viewing a Coarse or Fine Tuning Calibration on an Oscilloscope, at the end of the Example section.

Fine Tuning Calibration. The following discussion will describe how to perform a Fine Tuning Calibration:

NOTE

Fine Tuning Calibration is only required when single sideband operation (Special Function 17.0) has been selected on the Noise Figure Test Set and the measurement frequency is greater than 2400 MHz (SSB3).

There is no limit on the number of times that a Fine Tuning Calibration may be performed. But, a Fine Tuning Calibration is not needed each time a measurement is made.

a. Connect the equipment as shown below. The noise source should have a minimum ENR (Excess Noise Ratio) of 13 dB. The noise source should be placed as close as possible to the RF INPUT of the Noise Figure Test Set. If a preamplifier will be used in the measurement, the preamplifier may be placed between the noise source and the RF INPUT during the Fine Tuning Calibration. For Measurement Modes 1.6 and 1.7, when there is quite a bit of loss in the measurement setup, it is possible to do the Fine Tune Calibration by connecting the noise source directly to the Noise Figure Test Set RF INPUT. This will ensure that 13 dB of ENR is available for the Fine Tuning Calibration. In this case, the Fine Tuning Calibration can be performed using Special Function 36.3. In Measurement Modes 1.6 and 1.7, it is also possible to do a Fine Tuning Calibration with the external mixer in place and a preamplifier in the measurement system, to increase the available noise power at the Noise Figure Test Set RF INPUT. The preamplifier should be low noise or it may affect the Fine Tuning Calibration.

NOTE

Allow the equipment to warm up for twenty (20) minutes, before performing the Fine Tuning Calibration.

Noise Figure Test Set YIG Filter Calibration (cont'd)

(Special Functions 36 and 64)

Example (cont'd)

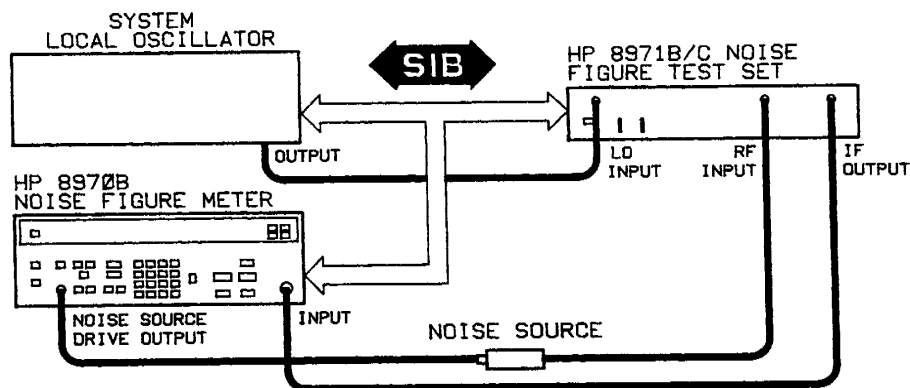

Figure 3-40. YIG Filter Calibration Setup

b. Select the start, stop and step size frequencies, using the START FREQ, STOP FREQ and STEP SIZE keys. Refer to the Sweep Detailed Operating Instruction for an explanation of START FREQ, STOP FREQ and STEP SIZE.

c. The Noise Figure Measurement System is now ready to perform a Fine Tuning Calibration. The Fine Tuning Calibration will be performed each time the Noise Figure Measurement System is calibrated, if Special Function 36.0 has been selected. Or, Special Function 36.3 can be selected to perform a Fine Tuning Calibration from the START FREQ to the STOP FREQ, immediately. The calibration will take from five to ten seconds per frequency point.

NOTE

When a Fine Tuning Calibration has been enabled and the decimal point is flashing in the NOISE FIGURE display, the Noise Figure Test Set is not at operating temperature. The calibration cannot be completed until the instrument is up to temperature. The Noise Figure Meter is waiting for the YIG filter temperature control loop, in the Noise Figure Test Set, to lock. The flashing decimal can also be caused by a power loss to the Noise Figure Test Set. The time needed for the temperature control loop to lock could be fifteen minutes, if the Noise Figure Test Set was cold or four to five minutes if the Noise Figure Test Set was warmed-up before it lost power. When the loop locks, the Fine Tuning Calibration will be completed.

It is normal for the system local oscillator to change frequency a number of times at each frequency point. This is part of the calibration process.

If data is read from the Noise Figure Meter, over the Hewlett-Packard Interface Bus, during a Fine Tuning Calibration, the Noise Figure Meter will output a special HP-IB code for the NOISE FIGURE window. For more information about this HP-IB code, refer to the Error Messages and Recovery Detailed Operating Instruction.

Noise Figure Test Set YIG Filter Calibration (cont'd)

(Special Functions 36 and 64)

Example (cont'd)

Measurement accuracy is dependent on the temperature inside the Noise Figure Test Set. If the temperature drifts approximately five degrees centigrade, since the last Fine Tuning Calibration, error twenty-eight (E28) will be generated. The Fine Tuning Calibration must be repeated using Special Function 36.3.

d. If a frequency not selected by START FREQ, STOP FREQ or STEP SIZE is desired, use Special Function 36.4. To select this frequency, press the FREQUENCY key and key in the frequency desired. Press ENTER. Then, press 36.4 SPECIAL FUNCTION, to start the Fine Tuning Calibration at the selected frequency.

NOTE

The passbands of the Noise Figure Meter and Noise Figure Test Set are aligned for the frequency fine tuned with Special Function 36.4. When the Noise Figure Measurement System is calibrated, for a CORRECTED NOISE FIGURE AND GAIN measurement, the noise contributed by the Noise Figure Measurement System is not factored out, at the frequency fine tuned by Special Function 36.4. Unless, the frequency fine tuned is a calibrated frequency point of the Noise Figure Measurement System.

e. To view the progress of the Fine Tuning Calibration, refer to Viewing a Coarse or Fine Tuning Calibration, at the end of the Example section.

Viewing a Coarse or Fine Tuning Calibration on an Oscilloscope or the HP 8757 Scalar Analyzer. The following discussion will describe how to view a Coarse or Fine Tuning Calibration on an analog oscilloscope or the HP 8757 Scalar Analyzer:

Using an Oscilloscope.

NOTE

An analog oscilloscope must be used with the Noise Figure Meter. A digital oscilloscope won't work with the Noise Figure Meter.

a. Connect the X-AXIS, Y-AXIS and Z-AXIS outputs on the rear panel of the Noise Figure Meter to the A, B and Z (or horizontal, vertical and Z) inputs of the oscilloscope. Select DC mode for all oscilloscope inputs.

b. Press 7.1 SPECIAL FUNCTION (or send HP-IB code A1) to display the test pattern on the oscilloscope screen.

c. Using the oscilloscope's position and gain controls, position the test pattern where desired.

d. Press 97.1 SPECIAL FUNCTION (or send HP-IB code Y9). The oscilloscope will now display the peaking (maximum power) at each frequency point for a Coarse or Fine Tuning Calibration, when enabled by Special Function 36 or 64.

NOTES

If a preamplifier is being used, the maximum and minimum oscilloscope display limits will need to be changed to view the noise peak at optimum scale. Special Function 97.1 sets the maximum limit to 500 and the minimum limit to 120.

Noise Figure Test Set YIG Filter Calibration (cont'd)

(Special Functions 36 and 64)

Example (cont'd)

To change the maximum limit and minimum limit, use the front panel keys of GAIN MAX (Special Function 8.4) and GAIN MIN (Special Function 8.3). The limits are entered by pressing the appropriate key, keying in the data and pressing ENTER.

e. When finished viewing the Coarse or Fine Tuning Calibration, press 97.2 SPECIAL FUNCTION (or send HP-IB code Y8). Special Function 97.2 disables the oscilloscope from displaying the Coarse or Fine Tuning Calibration and restores the GAIN MIN and GAIN MAX settings to where they were before Special Function 97.1 was enabled.

Using the HP 8757 Scalar Analyzer.

f. Connect the HP-IB connector of the Scalar Analyzer to the SYSTEM INTERFACE BUS connector of the Noise Figure Meter.

g. Press 47.2 SPECIAL FUNCTION. This enables the Scalar Analyzer on the System Interface Bus.

h. Press 97.1 SPECIAL FUNCTION (or send HP-IB code Y9).

NOTE

If a fine tuning calibration is being done, press CORRECTED NOISE FIGURE AND GAIN. If this key is not pressed, the display will disappear if the fine tuning calibration fails.

i. The Scalar Analyzer will now display the peaking (maximum power) at each frequency point for a Coarse or Fine Tuning Calibration, when enabled by Special Function 36 or 64.

NOTES

If a preamplifier is being used, the maximum and minimum display limits will need to be changed to view the noise peak at optimum scale. Special Function 97.1 sets the maximum limit to 500 and the minimum limit to 120.

To change the maximum limit and minimum limit, use the front panel keys of GAIN MAX (Special Function 8.4) and GAIN MIN (Special Function 8.3). The limits are entered by pressing the appropriate key, keying in the data and pressing ENTER.

j. When finished viewing the Coarse or Fine Tuning Calibration, press 97.2 SPECIAL FUNCTION (or send HP-IB code Y8). Special Function 97.2 disables the Scalar Analyzer from displaying the Coarse or Fine Tuning Calibration and restores the GAIN MIN and GAIN MAX settings to where they were before Special Function 97.1 was enabled. Disable commands to the Scalar Analyzer using 47.3 SPECIAL FUNCTION.



3-197.1 This Page Intentionally Left Blank

Noise Figure Test Set YIG Filter Calibration (cont'd)

(Special Functions 36 and 64)

Program Codes

HP-IB

For HP-IB codes, refer to the Procedure above.

Indications

For a Coarse and Fine Tuning Calibration, the left display shows each Noise Figure Test Set input frequency at which a calibration is made. The INSERTION GAIN display shows "8971." The NOISE FIGURE display shows "CAL."

When viewing a Coarse Tuning Calibration, a noise peak will be drawn on the oscilloscope for each frequency point being coarse tuned.

When viewing a Fine Tuning Calibration, a first pass at finding the noise peak is drawn and then a reference power line is drawn. Finally, a dot is placed where the actual noise peak was found. These steps are repeated for each frequency point to be fine tuned.

For a Coarse or Fine Tuning Calibration, three attempts will be made at each frequency point, to find the noise peak. After three attempts, error code E19 will be generated.

Comments

The causes that generate an error twenty-eight (E28) are given below:

- a. The YIG filter, in the Noise Figure Test Set, has not been fine tuned at the current frequency and coarse tune data is being used. The measurement may not be valid.
- b. The current frequency of the Noise Figure Test Set YIG filter has been interpolated from the Fine Tuning Calibration data. The measurement may not be valid.
- c. The Noise Figure Test Set has been fine tuned, but the temperature has drifted more than five degrees centigrade, since the last Fine Tuning Calibration. The YIG heater loop must be reset and new fine tuning data gathered. Use Special Function 36.3 to reset the heater loop and gather the new fine tune data.

Usually, the solution to error twenty-eight (E28) is to perform a Fine Tuning Calibration using Special Function 36.3.

Related Sections

Calibrate
Measurement Modes 1.0 through 1.9
Sweep

Noise Figure (Uncorrected) and Noise Figure and Gain (Corrected)

Description **UNCORRECTED NOISE FIGURE** measures the combined noise figure of the device under test and the measurement system (including the effect of the Noise Figure Test Set, local oscillator, mixer, cables, connectors and adapters).

CORRECTED NOISE FIGURE AND GAIN removes the measurement system noise contribution and allows only the noise figure and gain of the device under test to be displayed. The Noise Figure Meter must be calibrated in the measurement frequency range and measurement mode before a corrected noise figure and gain measurement can be made.

Procedure To measure uncorrected noise figure, press the **NOISE FIGURE** key.

To measure corrected noise figure and gain, press the **NOISE FIGURE AND GAIN** key. If the Noise Figure Meter is not correctly calibrated, error code E20 will be displayed.

Front Panel Key	Program Code HP-IB	Stored in Continuous Memory ¹	Can be Stored and Recalled	Preset (and HP-IB Clear) Conditions	Special Function 0.9 Conditions
NOISE FIGURE (UNCORRECTED)	M1	N	N	Active	Active
NOISE FIGURE AND GAIN (CORRECTED)	M2	N	N	Off	Off

¹Table categories are explained in the Preset Conditions and Power-Up Sequence Detailed Operating Instruction.

Example To measure corrected noise figure and gain:

LOCAL (keystrokes)	Measurement ● CORRECTED NOISE FIGURE AND GAIN
HP-IB (program codes)	M2

Program Codes For HP-IB program codes, refer to Procedure above.



Indications When the instrument is making uncorrected noise figure measurements, the **UNCORRECTED** LED above the **NOISE FIGURE** key is illuminated. The measurement result is displayed in the **NOISE FIGURE** display. In addition, the **INSERTION GAIN** display is blank.

Noise Figure (Uncorrected) and Noise Figure and Gain (Corrected) (cont'd)

Indications (cont'd)

When the instrument is making noise figure and gain measurements, the CORRECTED LED above the NOISE FIGURE AND GAIN key is illuminated. The gain of the device under test (DUT) appears in the INSERTION GAIN display and the noise figure of the DUT appears in the NOISE FIGURE display.

Comments

For CORRECTED NOISE FIGURE AND GAIN measurements, it is necessary to calibrate the instrument each time there is a change in measurement modes, equipment (except the DUT), or frequency parameters (if the new frequency parameters are outside of the calibrated range).

UNCORRECTED NOISE FIGURE and CORRECTED NOISE FIGURE AND GAIN measurements are always corrected for T_{cold} and ENR.

Measured noise can be expressed in a variety of units: F, F dB, Y, Y dB, and Te K. Refer to the Display Units Selection Detailed Operating Instruction for additional information.

The noise figure measurement range is 0 to 30 dB. The gain measurement range (for total noise figures less than 30 dB) is -20 to at least +40 dB, for the Noise Figure Meter.

High measurement system noise figure leads to high measurement uncertainty when measuring low gain devices. A low noise preamplifier, between the device under test and the measurement system, can lower system noise figure, and therefore reduce the measurement uncertainty. For more information, refer to the Preamplifier Selection Detailed Operating Instruction.

Related Sections

Calibrate
Display Units Selection
Preset Conditions and Power-Up Sequence

Power Measurements (Special Function 9)

Description

Special Function 9 measures noise power density in dB relative to -174 dBm/Hz with the noise source on or off. Either an approximate or a calibrated measurement can be made. The value -174 dBm/Hz was chosen because this is the thermal noise at 290K in a 1 Hz bandwidth. This special function can be used to make absolute power density measurements or simply to verify that the measurement system setup is operating and the signal path is complete. To exit from Special Function 9, press either UNCORRECTED NOISE FIGURE or CORRECTED NOISE FIGURE AND GAIN.

Procedure

To select a power density measurement, key in the corresponding Special Function code and then press the SPECIAL FUNCTION key.

Special Functions 9.3 and 9.4 require that a calibration be performed prior to activating the special function. If the calibration has not been performed, error E20 (not calibrated) is displayed and the special function is not activated.

Since the power measurements can be performed from any Measurement Mode, refer to the applicable Detailed Operating Instruction for the correct calibration procedures.

Special Function		Program Code HP-IB	Lights Special ¹ Function Key	Stored In Con- tinuous Memory	Can be Stored and Recalled	Special Function 0.0 Conditions	Preset (and HP-IB Clear) Conditions	Special Function 0.9 Conditions
Description	Code							
SOURCE Off (uncalibrated)	9.1	N5 or 9.1SP	N	Y	Y	Off	Off	Off
SOURCE On (uncalibrated)	9.2	N6 or 9.2SP	N	Y	Y	Off	Off	Off
SOURCE Off (calibrated)	9.3	N7 or 9.3SP	N	Y	Y	Off	Off	Off
SOURCE On (calibrated)	9.4	N8 or 9.4SP	N	Y	Y	Off	Off	Off

¹Table categories are explained in the Special Functions Detailed Operating Instruction.

Example

To select an uncalibrated power measurement with the noise source on:

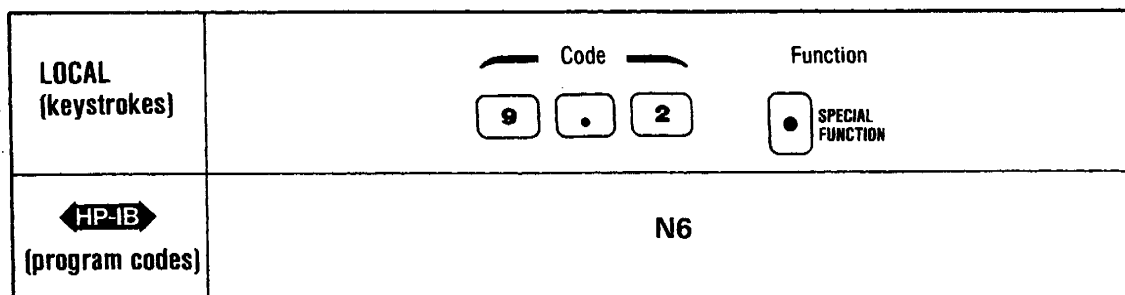

Power Measurements (cont'd)

(Special Function 9)

Program Codes

▶ HP-IB ◀

For HP-IB codes, refer to Procedure above.

Indications

The NOISE FIGURE display shows the selected power measurement result in dB.

Comments

Special Functions 9.3 and 9.4 measure the power density delivered from the DUT. The rest of the measurement system setup is corrected for by the calibration (second stage correction).

The units shown in the NOISE FIGURE display are dB referenced to 290K (-174 dBm/Hz). The equation is:

$$\text{Power displayed} = 10 \log \frac{\text{unknown power density}}{290} \text{ dB}$$

Special Functions 9.1 and 9.2 are similar to 9.3 and 9.4 except that they are not calibrated and they use nominal values for noise figure. These Special Functions are primarily used to verify that the measurement system is operating.

Special Functions 9.1 and 9.2 do not correct for the RF attenuators. There can be an error for very low power when the lowest RF attenuation is selected.

Related Sections

Calibrate
Measurement Modes 1.1 through 1.9
Special Functions

3-202 Intentionally Left Blank. *Pages 3-203 and 3-204 Are Non-Existent In This Manual*

Preset Conditions and Power-Up Sequence

(Includes Special Functions 0.0 and 0.9)

Description

NOTE

Special Function 0.9 will clear and reset the Noise Figure Meter to its default conditions. The default conditions are shown in Tables 3-12 and 3-13. Special Function 0.9 is covered in more detail in the following paragraphs.

Power-Up. When first turned on, the Noise Figure Meter performs a sequence of internal checks after which the instrument is ready to make measurements. During the power-up sequence, all front panel indicators light for approximately two seconds to allow the operator to determine if any are defective. Then, "Ctrl" appears in the INSERTION GAIN display and "on" or "OFF" appears in the NOISE FIGURE display. If the Noise Figure Meter is the System Interface Bus controller (Special Function 48.0) "on" will be displayed. If the Noise Figure Meter is not the System Interface Bus controller (Special Function 48.1) "OFF" will be displayed. Next, "Fr" appears in the INSERTION GAIN display and "CAL" appears in the NOISE FIGURE display for approximately five seconds while the Noise Figure Meter performs a frequency calibration. When the frequency calibration is completed, the Noise Figure Meter restores the same configuration it had before the power was removed. Except that:

- a. Sweep is always off.
- b. The measurement is always UNCORRECTED NOISE FIGURE.
- c. The instrument always turns on in local mode (instead of HP-IB remote).
- d. Calibration data is not retained when power is removed.
- e. Special Functions 25, 30 through 32, 35.1, 43, 44, 49.2 through 49.4 and 60 through 72 are not remembered when power is removed.

Preset Functions. The Noise Figure Meter has three levels of preset: Special Function 0.9, PRESET and Special Function 0.0. Special Function 0.9 is the upper level of preset; Special Function 0.9 sets all conditions set by PRESET and Special Function 0.0 and sets default values for some special functions, not set by PRESET. Special Function 0.9 does not reset the ENR (Excess Noise Ratio) tables and does not clear the IF calibration data. PRESET is the second level of preset; PRESET sets all conditions set by Special Function 0.0 and sets the default values for some of the special functions. Special Function 0.0 is the lowest level of preset. More detail is given for Special Function 0.9, PRESET and Special Function 0.0 in the following text.

Special Function 0.9 and PRESET. Special Function 0.9 and the PRESET key set the Noise Figure Meter to a known state. The front panel is set to the conditions listed in the "Special Function 0.9, Preset and HP-IB Clear Conditions" column in Table 3-12, Front Panel Summary. Table 3-13 lists the default data values that are set, by Special Function 0.9 and PRESET, for some of the special functions. Table 3-14, Special Functions Summary, in the Special Functions Detailed Operating Instruction provides a complete list of Special Function 0.9 and PRESET conditions for special functions.

In the "Program Code" column in Table 3-12, program codes that are equivalent to front panel keystrokes are listed. HP-IB codes control the Noise Figure Meter's functions over the HP-IB.

The "Stored in Continuous Memory" column in Table 3-12 indicates whether or not the status of a front panel key is retained when the Noise Figure Meter is turned off.

The "Can Be Stored and Recalled" column in Table 3-12 indicates whether or not the status of a front panel key can be stored in an internal storage register for recall at a later time.

Preset Conditions and Power-Up Sequence (cont'd)

(Includes Special Functions 0.0 and 0.9)

Table 3-12. Front Panel Summary

Front Panel Key	Program Code ↕ HP-IB ↕	Stored in Con- tinuous Memory	Can be Stored and Recalled	Special Function 0.9 and Preset (and HP-IB Clear) Conditions	References and Comments
AUTO Sweep	W1	N	N	Off	Sweep
CALIBRATE	CA	N	N	Off	Calibrate
DECREASE	DE	Y	N	1	Smoothing
ENTER	EN	—	—	—	General Operating Instructions
ENR	NR	Y	N	NC	ENR Table Entry
FREQ INCR	FN	Y	Y	20 MHz	Fixed Frequency Increment
▼	DN	—	—	—	Fixed Frequency Increment
▲	UP	—	—	—	Fixed Frequency Increment
FREQUENCY	FR	Y	Y	30 MHz	Fixed Frequency Tuning
INCREASE	IN	Y	N	1	Smoothing
NOISE FIGURE (UNCORRECTED)	M1	N	N	Active	Noise Figure (Uncorrected) and Noise Figure and Gain (Corrected)
NOISE FIGURE AND GAIN (CORRECTED)	M2	N	N	Off	Noise Figure (Uncorrected) and Noise Figure and Gain (Corrected)
PRESET	PR	—	—	—	Preset Conditions and Power-Up Sequence
RECALL	RC	—	—	—	Store and Recall
GRAPHIC SCALE					
Noise Min	NL	Y	Y	0 dB	Data Output to Oscilloscopes, Recorders and Plotters.
Noise Max	NU	Y	Y	8 dB	Data Output to Oscilloscopes, Recorders and Plotters.
Gain Min	GL	Y	Y	0 dB	Data Output to Oscilloscopes, Recorders and Plotters.
Gain Max	GU	Y	Y	40 dB	Data Output to Oscilloscopes, Recorders and Plotters.
SEQ	SQ	—	—	—	Sequence
SINGLE Sweep	W2	N	N	Off	Sweep
SPECIAL FUNCTION	SP	—	—	—	Special Functions
START FREQ	FA	Y	Y	10 MHz	Sweep
STEP SIZE	SS	Y	Y	20 MHz	Sweep
STOP FREQ	FB	Y	Y	1600 MHz	Sweep
STORE	ST	—	—	—	Store and Recall
Sweep and Calibrate Off (must be used to turn these functions off over the HP-IB)	W0	—	—	—	Sweep

Y = Yes, N = No, NC = No Change, — = Not Applicable

Preset Conditions and Power-Up Sequence (cont'd)

(Includes Special Functions 0.0 and 0.9)

Table 3-13. Special Function 0.9 and Preset Default Values for Special Functions

Special Function		Preset Default Value	Special Function 0.9 Default Value
Description	Code		
Addresses (HP-IB and SIB)			
Noise Figure Meter	40.0		8
System Local Oscillator	40.1		19
Noise Figure Test Set	40.2		10
Plotter	40.3		5
System Interface Bus	40.4		8
Pass Control	40.5		16
HP 8757 Scalar Analyzer	47.4		16
User Controlled Local Oscillator	96.2		20
HP 8757 Scalar Analyzer Measurement frequencies per display refresh	47.5	0	0
IF	3.0	30 MHz (Modes 1.1 and 1.3) 3500 MHz (Modes 1.6 and 1.8)	
LO Frequency	3.1	10000 MHz (Modes 1.2 and 1.4) 44000 MHz (Modes 1.7 and 1.9)	
Loss Compensation			
Before DUT	34.2	0 dB	0 dB
Temperature of Losses	34.3	OK	OK
After DUT	34.4	0 dB	0 dB
Measurement Mode 1.1, Measurement Mode 1.2, and Measurement Mode 1.3			
Start Frequency	1.1		
Stop Frequency	1.2		
Step Size	1.3		
Noise Figure Measurement System Internal IF		8000 MHz 12000 MHz 200 MHz	8000 MHz 12000 MHz 200 MHz
SSB2 IF	19.2	700 MHz	700 MHz
SSB3 IF	19.3	450 MHz	450 MHz
DSB IF	19.4	25 MHz	25 MHz
Oscilloscope Limits			
Noise Figure Lower Limit	8.1	0	0
Noise Figure Upper Limit	8.2	8	8
Gain Lower Limit	8.3	0	0
Gain Upper Limit	8.4	40	40
Plotter Functions			
Noise Pen	25.3	1	1
Gain Pen	25.4	2	2
Plot Title	25.5	HP 8970B Noise Figure Meter	
Programming the System LO			
Power Level	42.5	6 dBm	6 dBm
Set Sequence	35.2	1-9	1-9
Smoothing Factor	13.2	1	1
Spot ENR	5.3	15.2 dB	15.2 dB
System LO Sideband Crossover frequency; Measurement Modes 1.5 - 1.9	17.2	16 GHz	16 GHz
T _{cold}	6.0	296.5K	296.5K
Spot T _{hot}	5.4	9893K	9893K

Preset Conditions and Power-Up Sequence (cont'd)

(Includes Special Functions 0.0 and 0.9)

Description (cont'd)

Special Functions are off or set to their zero-suffix mode. The exception is Service Request, which is set to enable an HP-IB code error to cause an SRQ (Special Function 44.3). In addition, default data values are set for the special functions listed in Table 3-13.

Special Function 0.0. Special Function 0.0 initializes selected special functions. It is similar to PRESET except that default data values are not set. Existing values do not change. Refer to Table 3-14, Special Function Summary, in the Special Functions Detailed Operating Instruction for a complete list of Special Function 0.0 conditions.

Procedure

To set the Noise Figure Meter to a known state, press the PRESET key or key in 0.9 and press the SPECIAL FUNCTION key.

To initialize selected special functions, key in 0.0, then press the SPECIAL FUNCTION key.

Example

To initialize selected special functions:

<p>LOCAL (keystrokes)</p>	<p style="text-align: center;">Code</p> <p style="text-align: center;">Function</p>
<p>HP-IB (program codes)</p>	<p>CS</p>

Program Codes



Parameter	Program Code HP-IB
Special Function 0.9	0.9SP
PRESET	PR
Special Function 0.0	CS

Indications

After entering Special Function 0.9 or pressing PRESET, the INSERTION GAIN display shows "Fr" and the NOISE FIGURE display shows "CAL" while a frequency calibration is performed. After approximately five seconds, the left display shows 30 MHz, the INSERTION GAIN display is blank, and the NOISE FIGURE display shows noise figure in units of F dB. Also, the UNCORRECTED NOISE FIGURE LED is illuminated.

When Special Function 0.0 is executed, the SPECIAL FUNCTION key LED turns off if it was on.

Comments

Special Function 0.0 does not affect any data entered by special functions or front panel keys.

PRESET is identical to the Device Clear command over the HP-IB.

Preset Conditions and Power-Up Sequence (cont'd)

(Includes Special Functions 0.0 and 0.9)

Comments (cont'd)

PRESET does not effect calibration data or information in the ENR table.

Special Function 0.9, PRESET and Special Function 0.0 do not modify any data in the internal storage registers.

When using HP-IB code 0.9SP to issue Special Function 0.9, allow ten seconds to pass before giving the next command.

Related Sections

Calibration, Frequency
Special Functions



3-210 This Page Intentionally Left Blank

Programming The System LO (Special Function 42)

Description

Special Function 42 can be used to modify the predefined system local oscillator programs for the HP 8340B/8341B Sweep Oscillator (Special Function 41.4), HP 8350B Sweep Oscillator (Special Function 41.0), the HP 8671B/8672A Synthesized Signal Generators (Special Function 41.2), the HP 8673B/C/G Synthesized Signal Generator (Special Function 41.3) or a custom local oscillator (Special Function 41.5). Special Function 42 can also be used to define a new program for other system local oscillators provided the local oscillator is HP-IB compatible. However, a thorough understanding of the HP-IB program requirements and restrictions that apply to the system local oscillator is required.

The custom local oscillator program is different from the other predefined system LO programs. The other programs will only support a frequency prefix or suffix of two characters, maximum. The same is true for the power prefix or suffix. The custom local oscillator program will support a system LO that could require a maximum of twenty-two characters in the prefix and suffix. This is true for frequency and power.

The five predefined system LO programs are stored in permanent memory (ROM). Activating Special Function 41.0, 41.2, 41.3, 41.4 or 41.5 loads the corresponding predefined program from permanent memory into temporary memory (RAM). The programs stored in the permanent memory are never changed; only the program in temporary memory can be modified. Special Function 42 can change the program data that is stored in the temporary memory. One of the predefined programs or the last modified program is always present in the temporary memory. And, only the program in temporary memory can control the system LO.

Detailed examples will be used to explain the use of Special Function 42. However, a brief definition of the purpose of the individual parts of the program that can be changed using Special Function 42 will make the programs easier to understand:

- a. Special Function 42.0 is used to display and change the auxiliary commands. The purpose of the auxiliary commands are to set the system LO to continuous wave (CW) operation.
- b. Special Function 42.1 is used to display and change the CW prefix and suffix. The purpose of the prefix and suffix is to correctly format the frequency commands from the Noise Figure Meter to the system LO. The format is different for different LOs. Frequency data of up to five digits is located between the prefix and suffix. The frequency information is determined by the frequency parameters entered into the Noise Figure Meter during the measurement setup and by the measurement mode in which the instrument is operating. The custom local oscillator program (Special Function 41.5) overrides Special Function 42.1. Refer to Special Function 42.7.
- c. Special Function 42.2 is used to display and change the settling time (in ms). The purpose of the settling time is to ensure that the Noise Figure Meter waits a sufficient amount of time after issuing the frequency command and the auxiliary commands to allow the system LO output to stabilize.

Programming The System LO (cont'd) (Special Function 42)

Description (cont'd)

d. Special Functions 42.3 and 42.4 are used to display and change the minimum and maximum frequencies that the program will accept. These entries are in MHz. In most cases, they will represent the frequency capability of the system LO. However, they do not affect the system LO but are only used by the Noise Figure Meter to determine if a requested frequency parameter will be accepted. If an attempt to enter an out-of-range frequency is made, the Noise Figure Meter displays one of the invalid frequency entry error messages.

e. Special Function 42.5 is used to display and set the output signal power level of the system local oscillator. The allowable range is 0 to 30 dBm. If a level less than zero or greater than thirty is desired, the auxiliary commands (Special Function 42.0) need to be used to set the level. Do not use Special Function 42.5 to exceed the minimum or maximum output signal power level limits of the local oscillator being used. For Special Functions 41.0 through 41.4, Special Function 42.5 sets the command sequence (prefix and suffix) automatically as the power level (0 to 30 dBm) is entered. Special Function 41.5 (custom local oscillator program) requires that Special Function 42.6 be used with Special Function 42.5. The order is Special Function 42.6 then Special Function 42.5.

f. Special Function 42.6 is used only when the custom local oscillator (Special Function 41.5) program has been selected. Special Function 42.6 is used to properly format the command sequence that will set the output signal power level. Special Function 42.6 is used to set the power prefix and suffix in place of Special Function 42.0. The prefix and suffix are set much like Special Function 42.1 sets the frequency prefix and suffix. Once Special Function 42.6 is set up, Special Function 42.5 is used to set the power level. With Special Function 42.6 the prefix and suffix can total as many as twenty-four (24) characters. The twenty-four characters include the count character for the prefix, the prefix characters, the count character for the suffix and the characters for the suffix. The count characters indicate the number of characters that are in the prefix or suffix.

g. Special Function 42.7 is used only when the custom local oscillator (Special Function 41.5) program has been selected. Special Function 42.7 is used to properly format the command sequence that will set the output frequency. Special Function 42.7 is similar to Special Function 42.1 (prefix and suffix). With Special Function 42.1 the prefix and suffix, used to format the output frequency, is limited to four (4) ASCII characters. With Special Function 42.7 the prefix and suffix can total as many as twenty-four (24) characters. The twenty-four characters include the count character for the prefix, the prefix characters, the count character for the suffix and the characters for the suffix. The count characters indicate the number of characters in the prefix or suffix.

Predefined Program Listing

The listings for the five predefined programs are shown below. Each listing shows the data that is stored in permanent memory. Also shown are the system LO Commands (Special Functions 42.0 through 42.7) and the data that can be modified by each special function.

Programming The System LO (cont'd) (Special Function 42)

Predefined Program Listing (cont'd)

The following conventions are used in the program listings:

HP-IB

a. All HP-IB program codes consist of ASCII characters. The numbers and letters shown before the parentheses (in Special Functions 42.0, 42.1 and 42.5 through 42.7) are the ASCII characters that make up valid HP-IB program codes.

There is one exception, the custom local oscillator program. "Count" is not ASCII. Count is used to show the position in the program where the prefix and suffix count characters are to be placed. The count character indicates the number of characters in the prefix or suffix. (*cont'd on page 3-213*)

Programming The System LO (cont'd)

(Special Function 42)

**Predefined
Program
Listings
(cont'd)**

System LO Predefined Program Listings

System LO Commands (Special Function 42)	HP8340B/8341B (41.4) or HP 8350B (41.0) Program	HP 8671B/8672A Program (41.2)	HP 8673B/C/G Program (41.3)	Custom Local Oscillator Program (41.5)
42.0 Auxiliary Commands	(0) (0) (0) (0) (0) (0) (0) (0) (0) (0) (0) (0) (0) (0) (0)	M(77) } O(48) } AM off N(78) } 7(55) } FM off (0) (0) (0) (0) (0) (0) (0) (0) (0)	R (82) } 1 (49) } RF on D (68) } 0 (48) } Mod- A (65) } ulation 0 (48) } off P (80) 0 (48)	M (77) } O (79) } D (68) } : (58) } S (83) } T (84) } A (65) } T (84) } Space (32) O (79) F (70) F (70)
42.1 Prefix Suffix	C(67) W(87) M(77) Z(90)	P(80) (255) Z(90) O(48)	F (70) R (82) M (77) Z (90)	Special Function 42.1 is not used with Special Function 41.5. Refer to Special Function 42.7.
42.2 Settling Time	60 ms	20 ms	30 ms	30 ms
42.3 Minimum Frequency	2000 MHz	2000 MHz	2000 MHz	10 MHz
42.4 Maximum Frequency	26500 MHz	18000 MHz	26500 MHz	60000 MHz
42.5 Output Signal Power Level	6 dBm	7 dBm	8 dBm	8 dBm
42.6 Power Prefix Power Suffix				Count (4) P (80) O (79) W (87) Space (32) Count (5) Space (32) D (68) B (66) M (77) ; (59)
42.7 Frequency Prefix				Count (5) F (70) R (82) E (69) Q (81) Space (32)

Programming The System LO (cont'd) (Special Function 42)

**Predefined
Program
Listings
(cont'd)**

External LO Predefined Program Listings (cont'd)

System LO Commands (Special Function 42)	HP8340B/8341B (41.4) or HP 8350B (41.0) Program	HP 8671B/8672A Program (41.2)	HP 8673B/C/G Program (41.3)	Custom Local Oscillator Program (41.5)
Frequency Suffix				Count (5) Space (32) M (77) H (72) Z (90) ; (59)

b. The numbers shown within parentheses are the decimal equivalent of the required ASCII or count character. (It is this decimal value that is entered into the Noise Figure Meter) For example, in the first line of the listing for the HP 8671B/8672A program, the entry is M(77). The M is the first ASCII character of a valid HP-IB program code for the HP 8671B/8672A. The 77 is the decimal equivalent of the letter M.

The two exceptions to this rule are (0) in the HP 8340B/8341B/8350B program and (255) in the HP 8671B/8672A program. The (0) entry is used as a placeholder. It is ignored by the Noise Figure Meter and is not transmitted on the HP-IB. In the HP 8340B/8341B/8350B program (Special Functions 41.0 and 41.4), there are no preset auxiliary commands. This area contains zeros because no single program can control all possible HP 8340B/8341B/8350B configurations. This portion of the program must be correctly entered by the user to match the configuration of the HP 8340B/8341B/8350B used with the Noise Figure Meter. The (255) in the HP 8671B/8672A program is used by the Noise Figure Meter to establish that, when controlling the HP 8671B/8672A, leading zeros must be sent if they are required to complete five digits of frequency data.

c. The numbers shown without parentheses (in Special Functions 42.2, 42.3, and 42.4) are the actual values used for that function. For example, the "60 ms" shown as the settling time for the HP 8340B/8341B/8350B program is the actual settling time allowed by that program.

d. The comments following the brackets, such as in the HP 8671B/8672A program, are the functions performed by each HP-IB code. Note that many two-character HP-IB codes use the first character to establish the instrument function and the second character to establish the setting of that function.

In all the programs, a maximum five digits of frequency information are sent between the prefix and the suffix. This information is generated by the front panel settings of frequency parameters on the Noise Figure Meter.

Procedure

To activate a specific programming function, key in the corresponding Special Function code and then press the SPECIAL FUNCTION key.

Programming The System LO (cont'd) (Special Function 42)

Procedure
(con't)

Special Function		Program Code HP-IB	Lights Special ¹ Function Key	Stored in Con- tinuous Memory	Can be Stored and Recalled	Special Function 0.0 Conditions	Preset (and HP-IB Clear) Conditions	Special Function 0.9 Conditions
Description	Code							
Auxiliary Commands	42.0	AC or 42.0SP	N	Y	Y	NC	NC	0
CW Prefix and Suffix	42.1	PS or 42.1SP	N	Y	N	NC	NC	CW;MZ
Settling Time in ms	42.2	TM or 42.2SP	N	Y	N	NC	NC	60
Minimum Frequency in MHz	42.3	MN or 42.3SP	N	Y	N	NC	NC	2000
Maximum Frequency in MHz	42.4	MX or 42.4SP	N	Y	N	NC	NC	26500
Output Signal Power Level	42.5	PL or 42.5SP	N	Y	Y	NC	NC	6.0 dBm
Power Prefix and Suffix (Special Function 41.5)	42.6	PC or 42.6SP	N	Y	N	NC	NC	POW DBM;
Frequency Prefix and Suffix (Special Function 41.5)	42.7	FC or 42.7SP	N	Y	N	NC	NC	FREQ MHZ;

¹ Table categories are explained in the Special Functions Detailed Operating Instruction.

Entering Data

Special Function 42.0 allows for modification of the auxiliary commands of the program stored in temporary memory. If one of the predefined system LO programs is to be modified, Special Function 41.0 through 41.5 should be activated first to ensure that the correct program is in the temporary memory.



An auxiliary command is simply an HP-IB program code required to control one function of the system LO. Each program code consists of one or more ASCII character. The decimal equivalent of each ASCII character is stored in one of the fifteen data locations available for auxiliary commands.

The general procedure for entering data using Special Function 42.0 is as follows:

- a. Determine what system LO functions are to be controlled by the Noise Figure Meter.
- b. Use the system LO's manual to look up the HP-IB program codes for the above functions.
- c. Use Table 3-11, located in Remote Operation near the front of this section, to look up the decimal equivalent for each of the ASCII characters used for the program codes.
- d. On the Noise Figure Meter, press 42.0 SPECIAL FUNCTION to display the current number stored in the first of the fifteen data locations. Enter the decimal equivalent of the desired ASCII character from the front panel of the Noise Figure Meter. The allowable range of decimal values is 0 to 255.
- e. Press the ENTER key on the Noise Figure Meter's front panel. The next data location available for modification will appear in the Noise Figure Meter's left display. If no change to the existing data is desired, press ENTER to advance to the next data location.

Programming The System LO (cont'd)

(Special Function 42)

Procedure (cont'd)

f. Continue stepping through the data locations until all fifteen have been filled. If all of the auxiliary command data locations are not used in a specific application, always enter zeros in the remaining locations to avoid possible HP-IB command errors.

After all fifteen locations are displayed, the Noise Figure Meter returns to the previous front panel setup the next time ENTER is pressed. It is also possible to exit Special Function 42.0 at any time by pressing FREQUENCY (and still retain the data).

HP-IB

Special Function 42.1 allows for modification of the CW prefix and suffix commands (Special Functions 41.0 through 41.4 ONLY) for the system local oscillator program. The prefix is the system LO's HP-IB program code for CW. The suffix is the system LO's program code for MHz. The CW prefix and suffix commands are entered in a manner similar to the auxiliary commands (that is, the decimal equivalent of each ASCII character is entered into the Noise Figure Meter). However, the prefix and suffix HP-IB program codes must each be two ASCII characters or less because only four data locations are available for this Special Function. Enter zeros in any data locations that are not used. The allowable range of decimal values is 0 to 255.

For Special Functions 42.2 through 42.5, the decimal value is entered directly into the Noise Figure Meter. The settling time is entered in ms. The allowable range is 0 to 65530 ms. Frequency is entered in MHz. The allowable range is 0 to 99999 MHz.

The output power is entered in dBm. The allowable range is 0 to 30 dBm.

Special Function 42.6 is ONLY used with the custom local oscillator program (Special Function 41.5). Special Function 42.6 is used to properly format the command sequence that is used to set the output signal power level. Special Function 42.6 allows entry of the prefix and suffix for the output signal power level. The count character for the prefix, the prefix characters, the count character for the suffix and the suffix characters can be a maximum of twenty-four (24) characters. The prefix, suffix and count characters are entered in a manner similar to the auxiliary commands (that is, the decimal equivalent of each ASCII character is entered into the Noise Figure Meter. Since the count characters are decimal, they are entered as they are.) Once the prefix and suffix have been entered, Special Function 42.5 is used to enter the actual power level (0 to 30 dBm). For an example of using the custom local oscillator program and Special Function 42.6, refer to Example two (2) at the end of this instruction. With the other local oscillator programs (Special Functions 41.0 through 41.4), Special Function 42.5 sets the power level and the prefix and suffix for the output signal power level.

Special Function 42.7 is used with the custom local oscillator program (Special Function 41.5) ONLY. Special Function 42.7 is used to properly format the command sequence that is used to set the output frequency. Special Function 42.7 allows entry of the prefix and suffix for the output frequency. The count character for the prefix, the prefix characters, the count character for the suffix and the suffix characters can be a maximum of twenty-four (24) characters. The prefix, suffix and count characters are entered in a manner similar to the auxiliary commands (that is, the decimal equivalent of each ASCII character is entered into the Noise Figure Meter. Since the count characters are in decimal, they are entered as they are.) For an example of using the custom local oscillator program and Special Function 42.7, refer to Example two (2) at the end of this instruction.

Programming The System LO (cont'd)

(Special Function 42)

Procedure (cont'd)

Modified data can be entered in any order. For example, the settling time can be modified prior to changing the frequency prefix and suffix.

Running the System LO Program

Before the program can be run, several conditions must be met:

- a. The system local oscillator must be connected to the Noise Figure Meter's SYSTEM INTERFACE BUS connector with an HP-IB cable.
- b. Special Function 48.0 active (Noise Figure Meter is the system controller on System Interface Bus; Special Function 48.0 is the default setting, after using Special Function 0.9.).
- c. Special Function 46.0 active (Enable local oscillator on System Interface Bus; Special Function 46.0 is the default setting, after using Special Function 0.9.).
- d. The address of the system local oscillator must match the system local oscillator address that is stored in the Noise Figure Meter. Use Special Function 40.1 (system local oscillator address) to display and change the address, if necessary.
- e. Select the proper measurement mode, 1.1 through 1.9.
- f. The internal sweep of the system LO (if one exists) should be off.

Once the above conditions are met, the system LO program stored in the Noise Figure Meter's temporary memory runs whenever a frequency value is entered from the front panel of the Noise Figure Meter and the system LO is required. The program is also triggered each time an auxiliary command is changed when a system LO is connected.

When the program is running the following sequence occurs:

- a. A frequency command is given.
- b. The power level is set.
- c. The auxiliary commands are given.
- d. The Noise Figure Meter waits for the programmed settling time and then makes a measurement.

This sequence is repeated until all of the frequencies required by the measurement setup have been sent and the measurement results obtained.

HP-IB

Each time the frequency is changed the Noise Figure Meter issues an HP-IB command string. The Noise Figure Meter sends the following HP-IB commands to the system LO in the order indicated:

- a. REN and ATN are both set true.
- b. the LO's listen address is sent.
- c. ATN is released (that is, set false).
- d. the frequency command is sent.
- e. the power command is sent.
- f. the auxiliary commands are sent.
- g. carriage return (CR) and line feed (LF) are sent.

Programming The System LO (cont'd)

(Special Function 42)

Procedure (cont'd)

Because the frequency command precedes the auxiliary commands, a Preset or Initialize command cannot be used in the auxiliary commands. These type of commands will prevent the system LO from tuning to the required frequencies because after the LO tunes to the requested frequency, it will be reset to its original frequency.

Examples

Example 1—Modifying the Output Power Level for a Predefined Program

In example 1, the HP 8671B/8672A program is modified for different output power levels. Modifying the output power level will probably be the most frequent change made to this predefined program.

NOTE

The actual power level command is not contained in the predefined program. The power level is entered with a separate Special Function.

a. On the Noise Figure Meter, press 41.2 SPECIAL FUNCTION to load the HP 8671B/8672A program from permanent memory to temporary memory.

b. Changing the output power level is a simple procedure. Press 42.5 SPECIAL FUNCTION and key in the level desired (0 to 30 dBm). Press ENTER. Be sure not to exceed the limits of the system LO being used. For a power level less than 0 dBm or greater than 30 dBm, the auxiliary commands can be used.

c. Each time the power level is changed, step b is repeated.

Example 2—Using the Custom Local Oscillator Program

The Custom Local Oscillator (Special Function 41.5) Program is meant to be used with local oscillators that require anywhere from two (2) to twenty-two (22) ASCII characters to define the command sequence that sets the output frequency or output power. Special Functions 42.0 (Auxiliary Commands), 42.2 (Settling Time), 42.3 (Minimum Frequency), 42.4 (Maximum Frequency) and 42.5 (Output Signal Power Level) are still valid when using the Custom Local Oscillator Program. Special Function 42.1 is not valid with the Custom Local Oscillator Program.

The following procedure outlines the steps to be followed when using the Custom Local Oscillator Program:

a. Press 46.1 SPECIAL FUNCTION. This disables the system local oscillator commands on the System Interface Bus.

b. Press 41.5 SPECIAL FUNCTION. This brings the Custom Local Oscillator Program from permanent memory (ROM) to temporary memory (RAM).

NOTE

Once the parameters for Special Function 41.5 have been selected, enabling Special Function 41.5 again will set the default conditions.

c. Press 42.0 SPECIAL FUNCTION. Modify the auxiliary commands, if desired, as described earlier under Entering Data.

Programming The System LO (cont'd)

(Special Function 42)

Examples (cont'd)

d. Press 42.2 SPECIAL FUNCTION. Enter the settling time of the local oscillator being used.

e. Press 42.3 SPECIAL FUNCTION. Enter the minimum frequency of the local oscillator being used.

f. Press 42.4 SPECIAL FUNCTION. Enter the maximum frequency of the local oscillator being used.

g. Press 42.6 SPECIAL FUNCTION. Enter the count character for the prefix, the prefix characters, the count character for the suffix and the suffix characters for the output signal power level. The prefix and suffix can be found in the local oscillator's operating manual. The prefix and suffix are used to format the command sequence that sets the power level. The prefix, suffix, count character for the prefix and count character for the suffix can be a maximum of twenty-four (24) characters. The count character indicates the number of ASCII characters in the prefix or suffix. The prefix and suffix should be entered using the following format:

CPPPPCSSSS

C equals the decimal count character. P equals the prefix ASCII characters. S equals the suffix ASCII characters.

Use the front panel to enter the ASCII characters using their decimal equivalents. Since the count characters are in decimal, they are entered as they are. Press ENTER each time a decimal number is keyed in.

h. Press 42.5 SPECIAL FUNCTION. Enter the power level (0 to 30 dBm) using the front panel keys. Press ENTER.

i. Press 42.7 SPECIAL FUNCTION. Enter the count character for the prefix, the prefix characters, the count character for the suffix and the suffix characters for the output frequency. The prefix and suffix can be found in the local oscillator's operating manual. The prefix and suffix are used to format the command sequence that sets the output frequency. The prefix, suffix, count character for the prefix and count character for the suffix can be a maximum of twenty-four (24) characters. The count characters indicate the number of ASCII characters in the prefix or suffix. The prefix and suffix should be entered using the following format:

CPPPPCSSSS

C equals the decimal count character. P equals the prefix ASCII characters. S equals the suffix ASCII characters.

Use the front panel to enter the ASCII characters using their decimal equivalents. Since the count characters are in decimal, they are entered as they are. Press ENTER each time a decimal number is keyed in.

j. Press 46.0 SPECIAL FUNCTION. This enables the system local oscillator on the System Interface Bus.

Programs Available to Control The System LO (Special Function 41)

Description

Special Function 41 selects predefined programs to control the system LO. Special Function 41.0 selects the program for the HP 8350B Sweep Oscillator, Special Function 41.2 selects the program for the HP 8671B/8672A Synthesized Signal Generators, Special Function 41.3 selects the program for the HP 8673B/C/G Synthesized Signal Generator, Special Function 41.4 selects the program for the HP 8340B/8341B Sweep Oscillator and Special Function 41.5 selects the program for the custom local oscillator. A listing of these programs is contained in the Comments section of this instruction.

The programs are activated when Special Function 46.0 (enable system local oscillator on the System Interface Bus), a Measurement Mode (1.1 through 1.4 or 1.6 through 1.9), and the correct predefined program has been selected. The programs can be modified using Special Function 42 (System Local Oscillator Commands). Refer to the Programming the System Local Oscillator Detailed Operating Instruction for additional information on how to modify these programs.

Procedure

To select one of the predefined programs key in the corresponding Special Function code and then press the SPECIAL FUNCTION key.

Special Function		Program Code HP-IB	Lights Special ¹ Function Key	Stored in Continuous Memory	Can be Stored and Recalled	Special Function 0.0 Conditions	Preset (and HP-IB Clear) Conditions	Special Function 0.9 Conditions
Description	Code							
HP 8350B Sweep Oscillator Program	41.0	J0 or 41.0SP	N	Y	N	NC	NC	On
HP 8671B/8672A Synthesized Signal Generator Program	41.2	J2 or 41.2SP	N	Y	N	NC	NC	Off
HP 8673B/C/G Synthesized Signal Generator Program ²	41.3	J3 or 41.3SP	N	Y	N	NC	NC	Off
HP 8340B/8341B Sweep Oscillator Program	41.4	J4 or 41.4SP	N	Y	N	NC	NC	Off
Custom Local Oscillator Program	41.5	J5 or 41.5SP	N	Y	N	NC	NC	Off

¹ Table categories are explained in the Special Functions Detailed Operating Instruction.
² If the HP 8673B Option 008 or HP 8673D Synthesized Signal Generator is used as the system local oscillator, the auxiliary commands for the predefined program (Special Function 41.3) will need to be modified. For additional information, refer to the Comments section at the end of this instruction.

Example

To select the predefined program to control the HP 8671B/8672A:

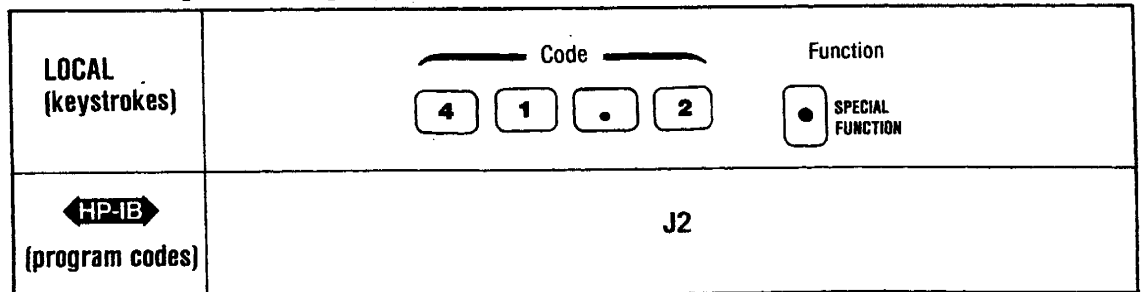

Programs Available to Control The System LO (cont'd)

(Special Function 41)

Program Codes

HP-IB

Comments

For HP-IB codes, refer to Procedure.

A listing of the predefined programs is provided here for a quick reference. A complete explanation of these programs and instructions on how to modify them are contained in the Programming the System LO Detailed Operating Instruction.

System LO Predefined Program Listings

System LO Commands (Special Function 42)	HP8340B/8341B (41.4) or HP 8350B (41.0) Program	HP 8671B/8672A Program (41.2)	HP 8673B/C/G Program (41.3)	Custom Local Oscillator Program (41.5)
42.0 Auxiliary Commands	(0) (0) (0) (0) (0) (0) (0) (0) (0) (0) (0) (0) (0) (0) (0) (0)	M(77) } 0(48) } AM off N(78) } 7(55) } FM off (0) (0) (0) (0) (0) (0) (0) (0) (0) (0)	R (82) } 1 (49) } RF on D (68) } 0 (48) } Mod- A (65) } ulation 0 (48) } off P (80) 0 (48)	M (77) } O (79) } D (68) } : (58) } S (83) } T (84) } Mod- A (65) } ulation T (84) } off Space(32) O (79) F (70) F (70)
42.1 Prefix Suffix	C(67) W(87) M(77) Z(90)	P(80) (255) Z(90) 0(48)	F (70) R (82) M (77) Z (90)	Special Function 42.1 is not used with Special Function 41.5. Refer to Special Function 42.7.
42.2 Settling Time	60 ms	20 ms	30 ms	30 ms
42.3 Minimum Frequency	2000 MHz	2000 MHz	2000 MHz	10 MHz
42.4 Maximum Frequency	26500 MHz	18000 MHz	26500 MHz	60000 MHz
42.5 Output Signal Power Level	6 dBm	7 dBm	8 dBm	8 dBm
42.6 Power Prefix Power Suffix				P (80) O (79) W (87) Space (32) Space (32) D (68) B (66) M (77) ; (59)

Programs Available to Control The System LO (cont'd) (Special Function 41)

**Comments
(cont'd)**

System LO Predefined Program Listings (cont'd)

System LO Commands (Special Function 42)	HP8340B/8341B (41.4) or HP 8350B (41.0) Program	HP 8671B/8672A Program (41.2)	HP 8673B/C/G Program (41.3)	Custom Local Oscillator Program (41.5)
42.7 Frequency Prefix				F (70) R (82) E (69) Q (81) Space (32)
Frequency Suffix				Space (32) M (77) H (72) Z (90) ; (59)

The HP 8673B Option 008 and HP 8673D Synthesized Signal Generators use K-band amplifiers. The amplifier is used when the output signal is greater than or equal to 16 GHz. The amplifier used in instruments prior to serial number prefix 2930A produce excessive broadband noise which can degrade the noise figure of the Noise Figure Measurement System. If one of these signal generators is being used as the system local oscillator and the output signal is greater than or equal to 16 GHz, the K-band amplifier must be removed from the output signal path.

Taking the K-band amplifier out of the signal path involves modifying the auxiliary commands (Special Function 42.0) for Special Function 41.3. The following HP-IB program code needs to be added to the auxiliary commands: 9SV. The decimal equivalent of each ASCII character (9SV) is entered into the Noise Figure Meter. The decimal equivalents of the ASCII characters are as follows: 9 (57), S (83) and V (86). Modifying the auxiliary commands is described in the Entering Data section of the Programming the System LO Detailed Operating Instruction.

After the K-band amplifier is removed, the local oscillator must be able to supply the minimum LO power required by the Noise Figure Test Set (+8 dBm for HP 8971B and standard HP 8971C, and 1 dBm for HP 8971C Option 001) over the oscillator's complete bandwidth. If the local oscillator can't supply this level, another local oscillator will have to be selected.

**Related
Sections**

Controller Capability of the Noise Figure Meter
Measurement Modes 1.1 through 1.9
Programming the System LO
Special Functions

RF Attenuation Selection

(Special Functions 60, 61, and 62)

Description

RF attenuation selection, display, and hold are available in all measurement modes. It should be noted, however, that only the hold capability (Special Function 62.0) is normally used by most operators. The hold is required during manual measurements (refer to the Manual Measurements Detailed Operating Instruction for additional information). The selection and display of specific RF attenuation settings are more likely to be used during adjustment procedures, performance tests, or troubleshooting procedures. In some specialized applications these capabilities can be helpful, but care must be exercised when using them. It is possible to introduce some very subtle errors in the measurements that the Noise Figure Meter may not be able to guard against. Additional information on how to use and interpret these Special Functions is contained in Section VIII, Service.¹

Procedure

To select a specific RF attenuation setting, display, or hold, key in the corresponding Special Function code and then press the SPECIAL FUNCTION key.

Special Function		Program Code HP-IB	Lights Special ² Function Key	Stored in Continuous Memory	Can be Stored and Recalled	Special Function 0.0 Conditions	Preset (and HP-IB Clear) Conditions	Special Function 0.9 Conditions
Description	Code							
RF Attenuation Selection								
Auto	60.0	R0 or 60.0SP	N	N	N	On	On	On
+20 dB	60.1	R1 or 60.1SP	Y	N	N	Off	Off	Off
+10 dB	60.2	R2 or 60.2SP	Y	N	N	Off	Off	Off
0 dB	60.3	R3 or 60.3SP	Y	N	N	Off	Off	Off
-10 dB	60.4	R4 or 60.4SP	Y	N	N	Off	Off	Off
-20 dB	60.5	R5 or 60.5SP	Y	N	N	Off	Off	Off
-30 dB	60.6	R6 or 60.6SP	Y	N	N	Off	Off	Off
Display RF Attenuator Settings								
Display RF Attenuator	61.0	SR or 61.0SP	N	N	N	Off	Off	Off
RF Attenuator Hold								
RF Attenuator Hold	62.0	RH or 62.0SP	Y	N	N	Off	Off	Off
² Table categories are explained in the Special Functions Detailed Operating Instruction.								

¹ Section VIII, Service, is in the Service Manual. The part number of the Service Manual is on the title page of this manual.

RF Attenuation Selection (cont'd)

(Special Functions 60, 61, and 62)

Example

To select the RF attenuator hold function:

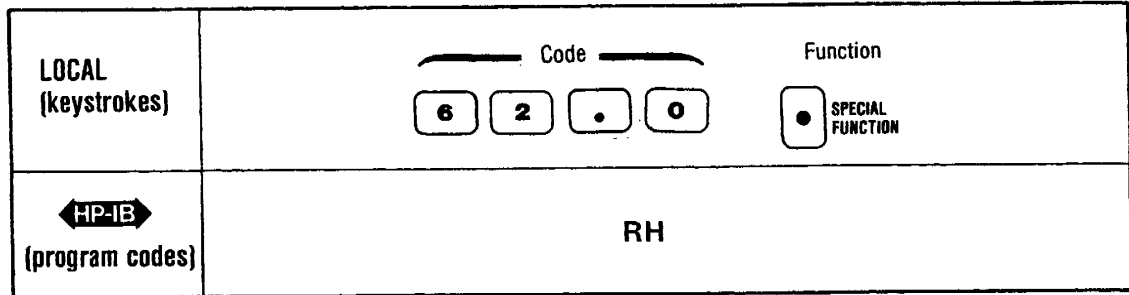

Program Codes



For HP-IB codes, refer to Procedure.

Indications

When Special Function 61 is implemented, four digits appear in the left display. The digits are either “1” (yes) or “0” (no) to indicate whether or not the corresponding 10 dB pads and 20 dB amplifier are switched into the Input Assembly circuits (see Service Sheet 1 in Section VIII, Service¹). The first, third, and fourth digits each represent -10 dB (10 dB Pad No. 1, 10 dB Pad No. 2, and 10 dB Pad No. 3, respectively). The second digit represents +20 dB (20 dB Input Gain Amplifier). To obtain the RF attenuator setting, add the attenuation that is represented by each digit in the display. For example, a display of “1 1 1 0” indicates an RF attenuation setting of 0 dB.

The following table lists the RF attenuation available (Special Functions 60.1 through 60.6) and the ones (1) and zeros (0) that are displayed, using Special Function 61.0.

Attenuation (dB)	Special Function	Attenuator or Amplifier			
		-10 dB	+20 dB	-10 dB	-10 dB
+20	60.1	0	1	0	0
+10	60.2	0	1	1	0
0	60.3	1	1	1	0
-10	60.4	1	0	0	0
-20	60.5	1	0	1	0
-30	60.6	1	0	1	1

Comments

If any of the 60 or 70 series of Special Functions (except 60.0 and 70.0) are active, the calibration sequence does not override them. Therefore, to calibrate on one range only, use any of these Special Functions except 60.0 or 70.0. It is also true that if any of these Special Functions are inadvertently active, the calibration sequence will not cover the expected gain range.

Related Sections

- Calibrate
- IF Attenuation Selection
- Manual Measurements
- Special Functions

¹ Section VIII, Service, is in the Service Manual. The part number of the Service Manual is on the title page of this manual.

Sequence (Includes Special Function 35)

Description The sequence feature allows the user to predetermine the recall order of the storage registers. Manual sequence (recall of registers one at a time) or automatic sequence (continuous recall of registers) can be selected.

Nine digits are used in a sequence. Any combination of registers 1 through 9 is allowed. Zeros used within a sequence are ignored.

Procedure To set the sequence (that is, the recall order), key in 35.2 SPECIAL FUNCTION. The register to be recalled at each step of the sequence is displayed in turn in the left display. If a change is desired, enter the new register number and press ENTER. If no change is desired, press ENTER to advance to the next step of the sequence. After all nine registers have been displayed, the Noise Figure Meter returns to normal measurement. Pressing the FREQUENCY key at any time terminates setting the sequence.

To select the manual sequence mode, key in 35.0 SPECIAL FUNCTION. The instrument steps through the defined sequence one step at a time each time the SEQ key is pressed. When the end of a sequence is reached, it starts over.

To select the automatic sequence mode, key in 35.1 SPECIAL FUNCTION. Press the SEQ key to start automatic sequencing. The instrument starts a continuous recall of registers in the predetermined sequence. To stop an automatic sequence, press the SEQ key again.

To clear the sequence (that is, set the sequence to 000 000 000), key in 35.3 SPECIAL FUNCTION.

To set the sequence to 1 through 9 in order, press PRESET.

Special Function		Program Code ◀ HP-IB ▶	Lights Special ¹ Function Key	Stored in Con- tinuous Memory	Can be Stored and Recalled	Special Function 0.0 Conditions	Preset (and HP-IB Clear) Conditions	Special Function 0.9 Conditions
Description	Code							
Manual Sequence	35.0	QM or 35.0SP	N	N	N	On	On	On
Automatic Sequence	35.1	QA or 35.1 SP	N	N*	N	Off	Off	Off
Set Sequence	35.2	QS or 35.2SP	N	Y	N	NC	1-9	1-9
Clear Sequence	35.3	QC or 35.3SP	N	N	N	Off	Off	Off

* Enables Special Function key LED to light when SEQ is pressed.
¹ Table categories are explained in the Special Functions Detailed Operating Instruction.

Sideband Selection

(Special Functions 2 and 17)

Description

Special Functions 2.0 through 2.2 are used when external down conversion is used with the Noise Figure Meter or Noise Figure Measurement System (Noise Figure Meter, Noise Figure Test Set and system local oscillator). Special Functions 2.0 through 2.2 convey to the Noise Figure Meter the sideband operation (double sideband, upper sideband or lower sideband) being used with the external down conversion. Special Function 2.3 is used when up-conversion is employed with the Noise Figure Meter or Noise Figure Measurement System.

Special Function 2 is used in Measurement Modes 1.1 through 1.4, 1.7 and 1.9. Special Function 2 is optional with Measurement Modes 1.6 or 1.8. Since the user controlled local oscillator, used in Measurement Modes 1.6 and 1.8, produces a fixed IF and is not controlled by the Noise Figure Measurement System, Special Function 2 is optional. However, if Special Function 3.2 (display user controlled local oscillator frequency in Measurement Modes 1.6 through 1.9) is desired, Special Function 2 will have to be used.

In Measurement Modes 1.2 or 1.7, one of the single sideband special functions must be selected or else an error code (E34) is displayed. The reason a double sideband measurement cannot be made in Modes 1.2 or 1.7 is that the frequency at which the measurement is being made is ambiguous. Therefore, one of the two single sideband special functions must be selected and the other sideband must be filtered out after the device under test (DUT) for a meaningful sweep. This eliminates any noise that is added by the DUT that may fall in the undesired sideband.

It is in Measurement Modes 1.1, 1.3, 1.4, 1.6, 1.8 and 1.9 that the choice between single or double sideband becomes necessary. The following brief description will help clarify the choices available:

a. Special Function 2.0 selects a double sideband measurement. The measured result is an average of the noise figure at two frequencies; in Measurement Modes 1.1 through 1.4, the system local oscillator frequency plus the IF and the system local oscillator minus the IF; in Measurement Modes 1.6 through 1.9, the user controlled local oscillator frequency plus the IF and the user controlled local oscillator frequency minus the IF.

b. Special Function 2.1 offsets the measurement frequency to the system local oscillator frequency minus the IF, in Measurement Modes 1.1 through 1.4. Special Function 2.1 offsets the measurement frequency to the user controlled local oscillator frequency minus the IF, in Measurement Modes 1.6 through 1.9. The Noise Figure Meter uses the ENR (Excess Noise Ratio) value of the offset measurement frequency. When using Special Function 2.1 an external filter is needed to eliminate the unwanted sideband.

c. Special Function 2.2 offsets the measurement frequency to the system local oscillator frequency plus the IF, in Measurement Modes 1.1 through 1.4. Special Function 2.2 offsets the measurement frequency to the user controlled local oscillator frequency plus the IF, in Measurement Modes 1.6 through 1.9. The Noise Figure Meter uses the ENR value of the offset measurement frequency. When using Special Function 2.2 an external filter is needed to eliminate the unwanted sideband.

d. Special Function 2.3 offsets the measurement frequency to the IF frequency minus the system local oscillator frequency, in Measurement Modes 1.1 through 1.4. Special Function 2.3 offsets the measurement frequency to the IF frequency minus the user controlled local oscillator frequency, in Measurement Modes 1.6 through 1.9. The Noise

Sideband Selection (cont'd)

(Special Functions 2 and 17)

Description (cont'd)

Figure Meter uses the ENR value of the offset measurement frequency. Special Function 2.3 is useful for frequency upconversion characterization.

Special Function 17 is only used in Measurement Modes 1.5 through 1.9. With the exception of Measurement Mode 1.5, the measurement signal is converted twice. The first conversion is done using an external mixer and the user controlled local oscillator. The second conversion is done using the Noise Figure Test Set and the system local oscillator. Special Function 17 selects a single sideband (SSB) or a double sideband (DBS) measurement, for the second conversion (or the first conversion, in the case of Measurement Mode 1.5). The sideband selection for the first conversion (Special Function 2) does not have to be the same as the sideband selection for the second conversion. And the sideband selection for the second conversion does not have to be the same as the sideband selection for the first conversion.

For measurement signals from 10 to 2400 MHz, single sideband operation is all that is available. For measurement signals greater than 2400 MHz, single and double sideband operation are available.

Normally, there is no need to change Special Function 17. Special Function 17.0 (single sideband) is the default. Special Function 17.0 has been chosen for best system performance.

The following descriptions will help to clarify Special Function 17:

a. Special Function 17.0 selects single sideband operation, for the Noise Figure Measurement System, when the Noise Figure Test Set input frequency is greater than 2400 MHz. Step c describes how to set the single sideband operation to either lower or upper sideband. The measurement frequency is offset from the system local oscillator frequency plus or minus the IF, depending upon how Special Function 17.2 has been set up.

The IF into the Noise Figure Meter (the difference between the Noise Figure Test Set input frequency and the system local oscillator frequency) is a fixed value of 450 MHz, set by the Noise Figure Measurement System. The IF can be changed using Special Function 19.3. For more information on Special Function 19.3, refer to the Fixed IF or LO Frequency Selection Detailed Operating Instruction. Normally, there is no reason to change Special Function 19.3.

b. Special Function 17.1 selects double sideband operation, for the Noise Figure Measurement System, when the Noise Figure Test Set input frequency is greater than 2400 MHz. The measured result is an average of the noise figure at two frequencies; the system local oscillator plus the IF, into the Noise Figure Meter and the system local oscillator minus the IF, into the Noise Figure Meter.

The IF (the difference between the Noise Figure Test Set input frequency and the system local oscillator frequency) is a fixed value of 25 MHz, set by the Noise Figure Measurement System. The IF can be changed using Special Function 19.4. For more information on Special Function 19.4, refer to the Fixed IF or LO Frequency Selection Detailed Operating Instruction. Normally, there is no need to change Special Function 19.4.

c. Special Function 17.2 is used with Special Function 17.0. Special Function 17.0 selects single sideband operation, for the Noise Figure Measurement System; Special

Sideband Selection (cont'd)

(Special Functions 2 and 17)

Description (cont'd)

Function 17.2 selects either lower or upper single sideband operation. Special Function 17.2 is used to enter a value from 2400 to 30000 MHz. Once the value is entered, a Noise Figure Test Set input frequency at or below the entered value will be a lower sideband measurement and a Noise Figure Test Set input frequency above the entered value will be an upper sideband measurement.

The procedure is to press 17.2 SPECIAL FUNCTION; key in the data (2400 to 30000 MHz) and press ENTER. Once Special Function 17.2 is set up, Special Function 17.0 may be keyed in, if desired. After PRESET, 2401 to 16000 MHz is lower sideband and 16000 to 26500 MHz is upper sideband.

Procedure

To select Special Function 2 or Special Function 17, key in the corresponding Special Function code and then press the SPECIAL FUNCTION key. In the case of Special Function 17.2, the SPECIAL FUNCTION key is pressed then data is keyed in and the ENTER key is pressed.

Special Function		Program Code HP-IB	Lights Special ¹ Function Key	Stored in Continuous Memory	Can be Stored and Recalled	Special Function 0.0 Conditions	Preset (and HP-IB Clear) Conditions	Special Function 0.9 Conditions
Description	Code							
Double Sideband (no frequency offset)	2.0	B0 or 2.0SP	N	Y	Y	On	On	On
Lower Single Sideband (measurement frequency less than LO frequency)	2.1	B1 or 2.1 SP	Y	Y	Y	Off	Off	Off
Upper Single Sideband (measurement frequency greater than LO frequency)	2.2	B2 or 2.2SP	Y	Y	Y	Off	Off	Off
Signal Up Conversion IF = F _{signal} plus F _{LO}	2.3	B3 or 2.3SP	Y	Y	Y	Off	Off	Off
Single Sideband measurement for Noise Figure Test Set input frequencies >2400 MHz	17.0	B4 or 17.0SP	N	Y	Y	On	On	On
Double Sideband measurement for Noise Figure Test Set input frequencies >2400 MHz	17.1	B5 or 17.1SP	N	Y	Y	Off	Off	Off
Lower and Upper sideband cross-over frequency	17.2	CF or 17.2SP	N	Y	Y	NC	16 GHz	16 GHz

¹ Table categories are explained in the Special Functions Detailed Operating Instruction.

Sideband Selection (cont'd)

(Special Functions 2 and 17)

Example

To select lower single sideband frequency offset:

<p>LOCAL (keystrokes)</p>	<div style="display: flex; justify-content: space-around; align-items: center;"> <div style="text-align: center;"> <p>Code</p> <div style="display: flex; justify-content: center; gap: 10px;"> <div style="border: 1px solid black; border-radius: 5px; padding: 2px 5px;">2</div> <div style="border: 1px solid black; border-radius: 5px; padding: 2px 5px;">.</div> <div style="border: 1px solid black; border-radius: 5px; padding: 2px 5px;">1</div> </div> </div> <div style="text-align: center;"> <p>Function</p> <div style="border: 1px solid black; border-radius: 5px; padding: 2px 5px; display: flex; align-items: center; justify-content: center;"> • <p style="font-size: 8px; margin: 0;">SPECIAL FUNCTION</p> </div> </div> </div>
<p style="text-align: center;">HP-IB</p> <p>(program codes)</p>	<p style="font-size: 24px; margin: 0;">B1</p>

Program Codes

For HP-IB codes, refer to Procedure.



Indications

For indications, refer to the "Lights Special Function Key" column in the table in Procedure above.

Related Sections

Measurement Modes
 Measurement Modes 1.1 through 1.9
 Special Functions

Smoothing (Averaging)

(Includes Special Function 13)

Description

The purpose of smoothing is to reduce jitter in both the NOISE FIGURE and INSERTION GAIN displays. Numbers that are sent to both of these displays are averaged before being displayed.

The Noise Figure Meter has two modes of smoothing: exponential and arithmetic (straight averaging). The equation for exponential smoothing is:

$$\text{new display} = \frac{\text{new measurement}}{n} + \frac{n-1}{n} (\text{previous display})$$

where n is the smoothing factor.

The equation for arithmetic is:

$$\text{new display} = \frac{n \text{ measurements}}{n}$$

where n is the smoothing factor.

The smoothing factor can range from 1 to 512 in factors of two. Each time the INCREASE key is pressed, the smoothing factor is doubled (until the smoothing factor is 512). Each time the DECREASE key is pressed, the smoothing factor is halved (until the smoothing factor is 1). A stable display can usually be obtained by increasing the smoothing factor.

When exponential smoothing is used for a fixed frequency measurement, the display is updated approximately five times per second for all smoothing factors. However, when a large smoothing factor is used, the Noise Figure Meter is slow to respond to changes in the noise measurement when tuning from one fixed frequency to another.

Arithmetic smoothing makes the number of measurements indicated by the smoothing factor and averages them before the result is displayed. The display is updated each time n measurements are made, where n is the smoothing factor. With a smoothing factor of 1, sixteen measurement updates are made each second. With a smoothing factor of 512, the measurement update interval is typically forty seconds to one minute.

Calibration and swept measurements always use arithmetic smoothing automatically. Either exponential or arithmetic smoothing can be selected for fixed frequency measurements.

Procedure

To display the smoothing factor, key in 13.2 SPECIAL FUNCTION. If a change is desired, key in the new smoothing factor and then press the ENTER key.

The smoothing factor can also be changed from the front panel. Press INCREASE for more smoothing or press DECREASE for less smoothing. Each time one of these keys is pressed the smoothing factor changes by a factor of two.

To select exponential or arithmetic smoothing for fixed frequency measurements only, key in the corresponding Special Function code and then press the SPECIAL FUNCTION key.

Smoothing (Averaging) (cont'd)

(Includes Special Function 13)

Procedure
(cont'd)

Special Function		Program Code ↔ HP-IB ↔	Lights Special ¹ Function Key	Stored in Con- tinuous Memory	Can be Stored and Recalled	Special Function 0.0 Conditions	Preset (and HP-IB Clear) Conditions	Special Function 0.9 Conditions
Description	Code							
Exponential smoothing mode for fixed frequency measurements	13.0	V0 or 13.0SP	N	Y	N	On	On	On
Arithmetic smoothing mode for fixed frequency measurements	13.1	V1 or 13.1SP	N	Y	N	Off	Off	Off
Displays and allows entry of smooth- ing factor	13.2	AF or 13.2SP	N	Y	N	NC	1	1

¹ Table categories are explained in the Special Functions Detailed Operating Instruction.

Example

To select exponential smoothing and a smoothing factor of 4:

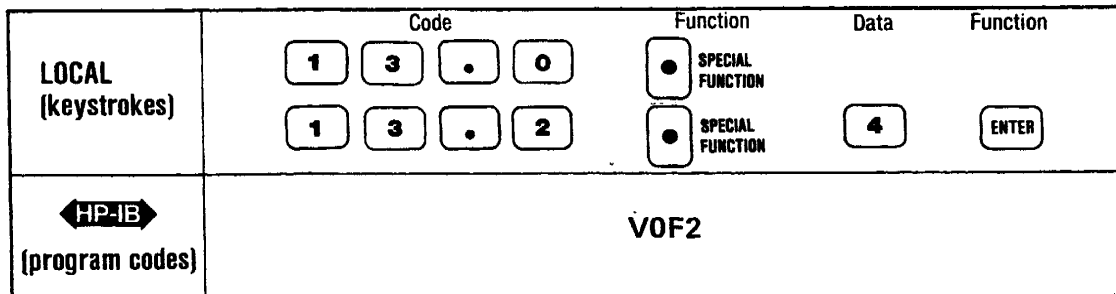

Program Codes
↔ HP-IB ↔

Parameter	Program Code ↔ HP-IB ↔
INCREASE	IN
DECREASE	DE
Smoothing Factor = 1	F0 or AF1EN
Smoothing Factor = 2	F1 or AF2EN
Smoothing Factor = 4	F2 or AF4EN
Smoothing Factor = 8	F3 or AF8EN
Smoothing Factor = 16	F4 or AF16EN
Smoothing Factor = 32	F5 or AF32EN
Smoothing Factor = 64	F6 or AF64EN
Smoothing Factor = 128	F7 or AF128EN
Smoothing Factor = 256	F8 or AF256EN
Smoothing Factor = 512	F9 or AF512EN

For HP-IB codes for Special Function 13, refer to Procedure above.

Smoothing (Averaging) (cont'd)

(Includes Special Function 13)

Indications The current smoothing factor is displayed in the left display whenever the INCREASE key or the DECREASE key is depressed.

Comments The smoothing factor can be changed while swept measurements are in progress. However, the smoothing factor cannot be changed during calibration.

For fixed frequency measurements, arithmetic smoothing is mainly useful in HP-IB systems. Exponential smoothing is best for reading measurement results on the front panel display or on an oscilloscope.

When using exponential smoothing, any time the fixed frequency changes, a number of measurements equal to the smoothing factor is made before any results are displayed. During this time the NOISE FIGURE display shows four dashes (— — — —).

In exponential smoothing, to reduce the settling time after a large measurement change, press the FREQUENCY key to reset the display to the current measurement value.

**Related
Sections**

Calibrate
Fixed Frequency Tuning
Special Functions
Sweep

Special Function Catalog (Special Function 50)

Description

Special Function 50 displays the contents of the eight line special functions catalog either sequentially or by individual line. The catalog can be used to quickly determine the present status of many of the special functions. For a concise explanation of the special function catalog, refer to the Special Function Catalog Summary shown below.

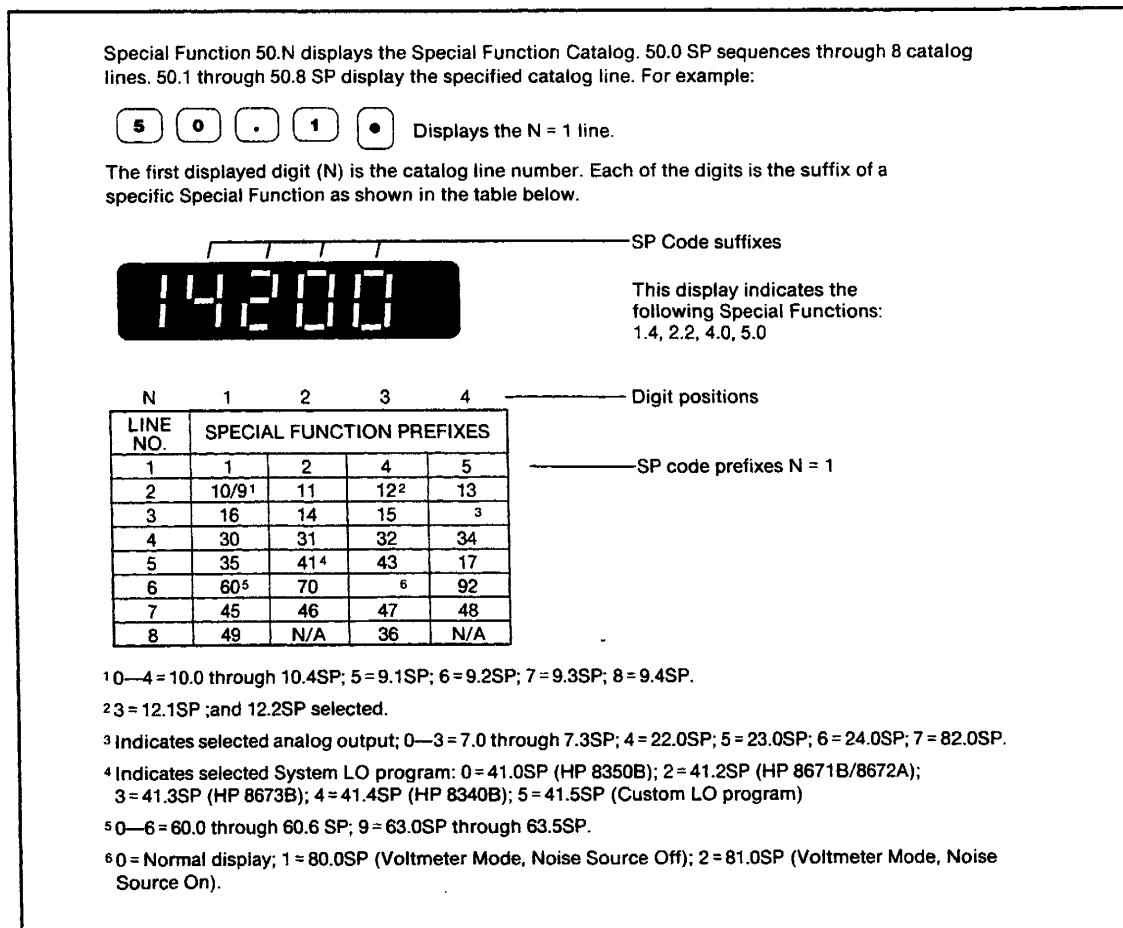

Figure 3-41. Special Functions

Special Function Catalog (cont'd) (Special Function 50)

Procedure

To select a specific special function catalog display, key in the corresponding Special Function code and then press the SPECIAL FUNCTION key.

Special Function		Program Code ↔ HP-IB ↔	Lights Special ¹ Function Key	Stored in Con- tinuous Memory	Can be Stored and Recalled	Special Function 0.0 Conditions	Preset (and HP-IB Clear) Conditions	Special Function 0.9 Conditions
Description	Code							
Sequence through all eight lines at once	50.0	G0 or 50.0SP	N	N	N	Off	Off	Off
Display Line 1	50.1	G1 or 50.1SP	N	N	N	Off	Off	Off
Display Line 2	50.2	G2 or 50.2SP	N	N	N	Off	Off	Off
Display Line 3	50.3	G3 or 50.3SP	N	N	N	Off	Off	Off
Display Line 4	50.4	G4 or 50.4SP	N	N	N	Off	Off	Off
Display Line 5	50.5	G5 or 50.5SP	N	N	N	Off	Off	Off
Display Line 6	50.6	G6 or 50.6SP	N	N	N	Off	Off	Off
Display Line 7	50.7	G7 or 50.7SP	N	N	N	Off	Off	Off
Display Line 8	50.8	G8 or 50.8SP	N	N	N	Off	Off	Off

¹ Table categories are explained in the Special Functions Detailed Operating Instruction.

Example

To display line 2 of the special function catalog:

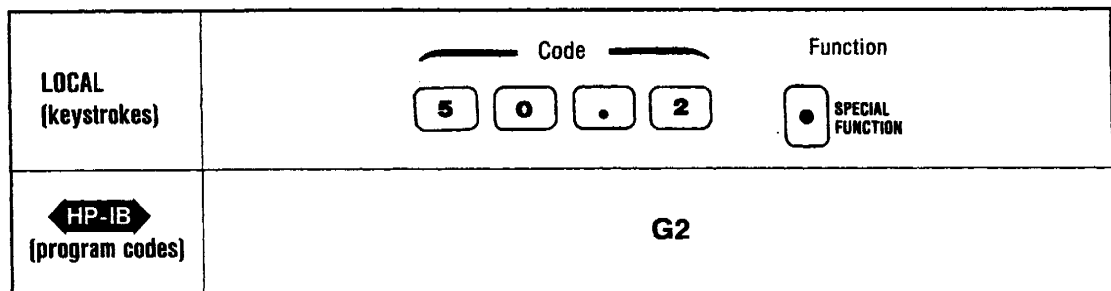

Program Codes



For HP-IB codes, refer to Procedure above.

Indications

When Special Function 50.0 is selected, the Noise Figure Meter automatically sequences through all eight lines, showing the status of each line for approximately one second in the left display.

When Special Functions 50.1 through 50.8 are selected, the status of the corresponding line is displayed in the left display until another function is selected.

Under the left display are reference characters N, 1, 2, 3, and 4. N refers to the line number and 1, 2, 3, and 4 refer to digit positions in the display.

Comments

To read the special function catalog information via HP-IB, use Special Functions 50.1 through 50.8 and read one line at a time. The HP-IB output format must be set to output all three displays (HP-IB code H1 or 43.1SP).

Related Sections

Special Functions

Special Functions

Description

General Information. Special Functions extend user control of the instrument beyond that normally available from dedicated front panel keys. They are accessed via keyboard entry of the appropriate numeric code terminated by the SPECIAL FUNCTION key. The codes consist of a prefix, decimal, and suffix. Special Functions are grouped by their prefixes into five categories as follows:

Prefix 0

This initializes selected Special Functions. Refer to Table 3-14, Special Function Summary, for a complete listing of initialized Special Function conditions.

Prefixes 1 to 49

These are User Special Functions which are used during normal instrument operation when a special configuration, a special measurement, or special information is required. These Special Functions are described in the Special Function Summary, Table 3-14.

Prefixes 50 to 59

These are Catalog Special Functions and are used to display the status of Special Function settings. Refer to the Special Function Catalog Detailed Operating Instruction for additional information.

Prefixes 60 to 79

These are Auxiliary Special Functions which are normally used for servicing the Noise Figure Meter. However, some of these Special Functions must be used for manual measurements (HOT and COLD). Refer to Section VIII (Service¹), and the IF Attenuation Selection and RF Attenuation Selection Detailed Operating Instructions for additional information.

Prefixes 80 to 99

These are the Service Special Functions used to assist in troubleshooting an instrument fault. The functions available are quite diverse — special internal measurements, software control, and special service tests and configurations. These Special Functions are discussed in detail in Section VIII, Service.¹

Special Function Summary Table. A summary of User, Catalog, and Auxiliary Special Functions is given in Table 3-14. Most of the Special Functions are explained in more detail in other operating instructions.

The “Lights Special Function Key” column indicates which Special Functions, when active, light the SPECIAL FUNCTION key LED on the front panel.

The “Stored in Continuous Memory” column indicates whether or not the status of a Special Function can be retained when power is removed from the Noise Figure Meter.

The “Can Be Stored and Recalled” column indicates whether or not the status of a Special Function can be stored in an internal storage register for recall at a later time.

The “Special Function 0.0 Conditions” column indicates the status of each Special Function (that is, on, off, or no change) when Special Function 0.0 is selected.

¹ Section VIII, Service, is in the Service Manual. The part number of the Service Manual is on the title page of this manual.

Special Functions (cont'd)

Description (cont'd)

The "Preset (and HP-IB Clear) Conditions" column indicates the status of each Special Function when the front panel PRESET key is pressed (or HP-IB code PR is sent). In addition, this column indicates default data values that are set for some Special Functions.

The "Special Function 0.9 Conditions" column indicates the status of each Special Function when Special Function 0.9 is selected. In addition, this column indicates default data values that are set for some Special Functions. Special Function 0.9 is the highest level of preset that the Noise Figure Meter has. Special Function 0.9 sets up everything that is set by PRESET or Special Function 0.0 and more. When Special Function 0.9 is selected it doesn't have any effect on the ENR tables or the IF calibration data. Special Function 0.9 does set the defaults for all Hewlett-Packard Interface Bus (HP-IB) and System Interface Bus (SIB) addresses and the system local oscillator programs.

Procedure

To use a Special Function, key in the corresponding code, then press the SPECIAL FUNCTION key.

Example

To select Measurement Mode 1.1 (Special Function 1.1):

<p>LOCAL (keystrokes)</p>	<div style="display: flex; justify-content: space-around; align-items: center;"> <div style="text-align: center;"> <p>Code</p> <div style="display: flex; gap: 10px;"> <div style="border: 1px solid black; padding: 2px 10px; border-radius: 5px;">1</div> <div style="border: 1px solid black; padding: 2px 10px; border-radius: 5px;">.</div> <div style="border: 1px solid black; padding: 2px 10px; border-radius: 5px;">1</div> </div> </div> <div style="text-align: center;"> <p>Function</p> <div style="border: 1px solid black; padding: 5px; border-radius: 5px; display: inline-block;"> ● SPECIAL FUNCTION </div> </div> </div>
<p style="text-align: center;">HP-IB</p> <p>(program codes)</p>	<p style="font-size: 1.5em; margin: 0;">E1</p>

Indications

The numeric code appears in the left display as it is being entered. Pressing the SPECIAL FUNCTION key activates the selected Special Function. Refer to the "Lights Special Function Key" column in Table 3-14 for a list of Special Functions that light the key LED.

Related Sections

- Calibration, Frequency
- Calibration, IF Attenuators
- Calibration, Input Gain Selection
- Controller Capability of the Noise Figure Meter
- Data Output to Oscilloscopes, Recorders and Plotters
- Display Control
- Display Resolution
- Display Units Selection
- Fixed IF or LO Frequency Selection
- HP-IB and System Interface Bus (SIB) Addresses
- IF Attenuation Selection
- Loss Compensation
- Manual Measurement Functions
- Measurement Mode 1.0
- Measurement Mode 1.1
- Measurement Mode 1.2
- Measurement Mode 1.3
- Measurement Mode 1.4

Special Functions (cont'd)

Related Sections (cont'd)

Measurement Mode 1.5
Measurement Mode 1.6
Measurement Mode 1.7
Measurement Mode 1.8
Measurement Mode 1.9
Noise Figure Test Set YIG Filter Calibration
Power Measurements
Preamplifier Selection
Preset Conditions and Power-Up Sequence
Programming the System LO
Programs Available to Control the System LO
RF Attenuation Selection
Sequence
Sideband Selection
Smoothing
Special Function Catalog
Spot ENR, T_{hot} , T_{cold} and ENR Table Selection
System Interface Bus Control
Temperature Units Selection
Trigger Selection

3-238 This Page Intentionally Left Blank

Table 3-14. Special Function Summary (1 of 15)

Special Function		Program Code HP-IB	Description	Lights Special Function Key	Stored in Continuous Memory	Can be Stored and Recalled	Special Function 0.0 Conditions	Preset (and HP-IB Clear) Conditions	Special Function 0.9 Conditions	References and Comments
Name	Code*									
Initialize Special Functions	0.0	CS	Initializes many Special Functions	N	—	—	—	—	—	Preset Conditions and Power Up Sequence
	0.9	—	Initializes or sets defaults for all Special Functions	N	N	N	—	—	—	
Measurement Mode Selection (Noise Figure Meter)	1.0	E0	Mode 1.0 (10-1600 MHz; 2047 MHz, opt 020, Meas)	N	Y	Y	On	On	On	Measurement Mode 1.0
	1.1	E1	Mode 1.1 (fixed IF; variable freq. sys. LO)	N	Y	Y	Off	Off	Off	Measurement Mode 1.1
	1.2	E2	Mode 1.2 (variable IF; fixed freq. sys. LO; SSB)	N	Y	Y	Off	Off	Off	Measurement Mode 1.2
	1.3	E3	Mode 1.3 (fixed IF; variable freq. sys. LO; mixer is DUT)	N	Y	Y	Off	Off	Off	Measurement Mode 1.3
	1.4	E4	Mode 1.4 (variable IF; fixed freq. sys. LO; mixer is DUT)	N	Y	Y	Off	Off	Off	Measurement Mode 1.4
Measurement Mode Selection (Noise Figure Measurement System)	1.5	E5	Mode 1.5 (10 to 26500 MHz)	N	Y	Y	Off	Off	Off	Measurement Mode 1.5
	1.6	E6	Mode 1.6 (fixed IF; variable user controlled LO)	N	Y	Y	Off	Off	Off	Measurement Mode 1.6
	1.7	E7	Mode 1.7 (variable IF; fixed freq. user controlled LO; SSB)	N	Y	Y	Off	Off	Off	Measurement Mode 1.7
	1.8	E8	Mode 1.8 (fixed IF; variable user controlled LO; mixer in DUT)	N	Y	Y	Off	Off	Off	Measurement Mode 1.8
	1.9	E9	Mode 1.9 (variable IF; fixed user controlled LO; mixer in DUT.)	N	Y	Y	Off	Off	Off	Measurement Mode 1.9
Sideband Frequency Offset	2.0	B0	Double Sideband (no offset)	N	Y	Y	On	On	On	Sideband Selection
	2.1	B1	Lower Single Sideband ($F_{\text{signal}} < F_{\text{LO}}$)	Y	Y	Y	Off	Off	Off	
	2.2	B2	Upper Single Sideband ($F_{\text{signal}} > F_{\text{LO}}$)	Y	Y	Y	Off	Off	Off	
	2.3	B3	Signal Up Conversion $IF = F_{\text{signal}} + F_{\text{LO}}$	Y	Y	Y	Off	Off	Off	

*Most Special Functions can be programmed using either the code number followed by SP or the HP-IB Code.
N = No; Y = Yes; NC = No Change; — = Not Applicable

Table 3-14. Special Function Summary (2 of 15)

Special Function		Program Code HP-IB	Description	Lights Special Function Key	Stored in Continuous Memory	Can be Stored and Recalled	Special Functions 0.0 Conditions	Preset (and HP-IB Clear) Conditions	Special Function 0.9 Conditions	References and Comments
Name	Code*									
Enter IF and LO Frequencies	3.0	IF	IF (for Modes 1.1 & 1.3) (for Modes 1.6 & 1.8)	N	Y	Y	NC	30 MHz 3 500 MHz	30 MHz 3 500 MHz	Fixed IF or LO Frequency Selection
	3.1	LF	LO (for Modes 1.2 & 1.4) (for Modes 1.7 & 1.9)	N	Y	Y	NC	10 000 MHz 44 000 MHz	10 000 MHz 44 000 MHz	Measurement Modes, Special Function 1
	3.2	UL	Display the User Controlled LO Frequency in Measurement Modes 1.6 through 1.9	N	N	N	Off	Off	Off	
Control Function Selection	4.0	none	Normal Talker and Listener	N	Y	N	NC	NC	On	Controller Capability of the Noise Figure Meter
	4.1 ¹	—		—	—	—	—	—	—	
	4.2	none	Talk Only	N	Y	N	NC	NC	Off	
ENR, THOT Settings and ENR Table Selection	5.0	S0	Use ENR Table	N	Y	Y	On	On	On	Spot ENR, T _{HOT} , T _{COLD} and ENR Table Selection
	5.1	S1	Use Spot ENR	Y	Y	Y	Off	Off	Off	
	5.2	SE	Display Current ENR in dB	N	N	N	Off	Off	Off	
	5.3	NR	Enter and Use Spot ENR	N	Y	Y	NC	15.2 dB	15.2 dB	
	5.4	TH	Enter and Use THOT	N	Y	Y	NC	9893K	9893K	
	5.5	SN	Enter Noise Source Identifier	N	Y	N	NC	NC	NC	
	5.6	NS	Noise Source catalog	N	N	N	NC	NC	NC	
	5.7	EC	ENR table number for calibration	N	Y	Y	NC	0	0	
5.8	EM	ENR table number for the measurement	N	Y	Y	NC	0	0		
TCOLD Setting	6.0	TC	Enter TCOLD	N	Y	Y	NC	296.5K	296.5K	Spot ENR, T _{HOT} , T _{COLD} and ENR Table Selection
Output to Oscilloscope	7.0	A0	Noise Figure and Gain	N	Y	N	On	On	On	Data Output to Oscilloscopes, Recorders and Plotters
	7.1	A1	Test Pattern	N	Y	N	Off	Off	Off	
	7.2	A2	Noise Figure Only	N	Y	N	Off	Off	Off	
	7.3	A3	Gain Only	N	Y	N	Off	Off	Off	
	7.4	A8	Cursor enabled for oscilloscope display	N	Y	N	On	On	On	
	7.5	A9	Cursor disabled for oscilloscope display	N	Y	N	Off	Off	Off	

*Most Special Functions can be programmed using either the code number followed by SP or the HP-IB Code.
N = No; Y = Yes; NC = No Change; — = Not Applicable

¹Special Function 4.1 is no longer used. Refer to Special Function 46.

Table 3-14. Special Function Summary (3 of 15)

Special Function		Program Code HP-IB	Description	Lights Special Function Key	Stored in Continuous Memory	Can be Stored and Recalled	Special Functions 0.0 Conditions	Preset (and HP-IB Clear) Conditions	Special Function 0.9 Conditions	References and Comments
Name	Code*									
Enter Oscilloscope Limits	8.1	NL	Noise Figure Lower Limit	N	Y	Y	NC	0	0	Data Output to Oscilloscopes, Recorders and Plotters
	8.2	NU	Noise Figure Upper Limit	N	Y	Y	NC	8	8	
	8.3	GL	Gain Lower Limit	N	Y	Y	NC	0	0	
	8.4	GU	Gain Upper Limit	N	Y	Y	NC	40	40	
Power Measurements	9.1	N5	SOURCE Off (uncal)	N	Y	Y	Off	Off	Off	Power Measurements
	9.2	N6	SOURCE On (uncal)	N	Y	Y	Off	Off	Off	
	9.3	N7	SOURCE Off (cal)	N	Y	Y	Off	Off	Off	
	9.4	N8	SOURCE On (cal)	N	Y	Y	Off	Off	Off	
Noise Figure Display Units	10.0	N0	F dB	N	Y	Y	On	On	On	Display Units Selection
	10.1	N1	F	N	Y	Y	Off	Off	Off	
	10.2	N2	Y dB	N	Y	Y	Off	Off	Off	
	10.3	N3	Y	N	Y	Y	Off	Off	Off	
	10.4	N4	TeK	N	Y	Y	Off	Off	Off	
Select Noise Source Temp. Units for Data Input	11.0	D0	K	N	Y	Y	On	On	On	Temperature Units Selection (Also see Special Functions 5.4, 6.0 and 34.3)
	11.1	D1	°C	N	Y	Y	Off	Off	Off	
	11.2	D2	°F	N	Y	Y	Off	Off	Off	
Display Resolution	12.0	X0	Maximum Resolution	N	Y	N	On	On	On	Display Resolution
	12.1	X1	Less Res. on Noise Figure	N	Y	N	Off	Off	Off	
	12.2	X2	Less Res. on Gain	N	Y	N	Off	Off	Off	
Smoothing (Averaging)	13.0	V0	Exponential Smoothing	N	Y	N	On	On	On	Smoothing (Averaging)
	13.1	V1	Arithmetic Averaging	N	Y	N	Off	Off	Off	
	13.2	AF	Smoothing Factor	N	Y	N	NC	1	1	

*Most Special Functions can be programmed using either the code number followed by SP or the HP-IB Code.
N = No; Y = Yes; NC = No Change; — = Not Applicable

Table 3-14. Special Function Summary (4 of 15)

Special Function		Program Code HP-IB	Description	Lights Special Function Key	Stored in Continuous Memory	Can be Stored and Recalled	Special Functions 0.0 Conditions	Preset (and HP-IB Clear) Conditions	Special Function 0.9 Conditions	References and Comments
Name	Code*									
Manual Measurement Functions	14.1	MC	Cold Measurement (SOURCE-off)	N	Y	Y	Off	Off	Off	Manual Measurement Functions
	14.2	MH	Hot Measurement (SOURCE-on)	N	Y	Y	Off	Off	Off	
	14.3	CC	Cold Calibration (SOURCE-off)	N	Y	Y	Off	Off	Off	
	14.4	CH	Hot Calibration (SOURCE-on)	N	Y	Y	Off	Off	Off	
	15.0	P0	Display Current Measurement	N	N	Y	On	On	On	
	15.1	P1	Display Manual Measurement Results	Y	N	Y	Off	Off	Off	
Display Control	16.0	DF	Measurement frequency is displayed in left window.	N	Y	Y	On	On	On	Display Control
	16.1	DI	Input to Noise Figure Meter (Modes 1.0 through 1.4) or Noise Figure Test Set (Modes 1.5 through 1.9) displayed.	N	Y	Y	Off	Off	Off	
	16.2	BF	Frequency display is blanked.	N	Y	Y	Off	Off	Off	
	16.3	BA	All displays are blanked.	N	Y	Y	Off	Off	Off	
Sideband Frequency Offset	17.0	B4	Single Sideband Operation (Modes 1.5 through 1.9)	N	Y	Y	On	On	On	Sideband Selection
	17.1	B5	Double Sideband Operation (Modes 1.5 through 1.9)	N	Y	Y	Off	Off	Off	
	17.2	CF	Upper and Lower sideband crossover frequency selection	N	Y	Y	NC	16 GHz	16 GHz	
Noise Figure Measurement System Internal IF	19.2	S2	Internal IF for SSB2	N	Y	Y	NC	700 MHz	700 MHz	Fixed IF or LO Frequency Selection
	19.3	S3	Internal IF for SSB3	N	Y	Y	NC	450 MHz	450 MHz	
	19.4	S4	Internal IF for DSB	N	Y	Y	NC	25 MHz	25 MHz	
	19.5	S5	Display Noise Figure Meter input frequency	N	N	N	NC	NC	NC	

*Most Special Functions can be programmed using either the code number followed by SP or the HP-IB Code.
N = No; Y = Yes; NC = No Change; — = Not Applicable

Table 3-14. Special Function Summary (5 of 15)

Special Function		Program Code HP-IB	Description	Lights Special Function Key	Stored in Continuous Memory	Can be Stored and Recalled	Special Functions 0.0 Conditions	Preset (and HP-IB Clear) Conditions	Special Function 0.9 Conditions	References and Comments
Name	Code*									
Recorder Functions	20.0	LL	Go to Lower Left	N	N	N	Off	Off	Off	Data Output to Oscilloscopes, Recorders and Plotters
	21.0	UR	Go to Upper Right	N	N	N	Off	Off	Off	
	22.0	A4	Plot Noise Figure	N	Y	N	Off	Off	Off	
	23.0	A5	Plot Gain	N	Y	N	Off	Off	Off	
	24.0	A6	X-AXIS Output is Noise Figure and Y-AXIS Output is Gain (Strip Chart mode)	N	Y	N	Off	Off	Off	
Plotter Functions	25.0	PA	Plot grid and data	N	N	N	Off	Off	Off	Data Output to Oscilloscopes, Recorders and Plotters
	25.1	PG	Plot grid and axes labels	N	N	N	Off	Off	Off	
	25.2	PD	Plot data only	N	N	N	Off	Off	Off	
	25.3	NP	Select noise pen number	N	N	N	NC	1	1	
	25.4	GP	Select gain pen number	N	N	N	NC	2	2	
	25.5	WT	Select plot name	N	N	N	NC	HP 8970B Noise Figure Meter	HP 8970B Noise Figure Meter	
Trigger Selection	30.0	T0	Free Run	N	N	N	On	On	On	Trigger Selection
	30.1	T1	Hold	N	N	N	Off	Off	Off	
	30.2	T2	Execute	N	N	N	Off	Off	Off	
Frequency Calibration	31.0	Y0	Automatic	N	N	N	On	On	On	Calibration, Frequency
	31.1	Y1	Disable Frequency Cal	N	N	N	Off	Off	Off	
	31.2	Y2	Perform 1 Frequency Cal	N	N	N	Off	Off	Off	
Input Gain Calibration	32.0	C0	20, 10 and 0 dB	N	N	N	On	On	On	Calibration, Input Gain Selection
	32.1	C1	10, 0 and -10 dB	Y	N	N	Off	Off	Off	
	32.2	C2	0, -10 and -20 dB	Y	N	N	Off	Off	Off	
	32.3	C3	-10, -20 and -30 dB	Y	N	N	Off	Off	Off	

*Most Special Functions can be programmed using either the code number followed by SP or the HP-IB Code.
N = No; Y = Yes; NC = No Change; — = Not Applicable

Table 3-14. Special Function Summary (6 of 15)

Special Function		Program Code HP-IB	Description	Lights Special Function Key	Stored in Continuous Memory	Can be Stored and Recalled	Special Function 0.0 Conditions	Preset (and HP-IB Clear) Conditions	Special Function 0.9 Conditions	References and Comments
Name	Code*									
IF Attenuators Calibration	See footnote below ¹		Calibrate IF Attenuators	N	Y	N	Off	Off	Off	Calibration, IF Attenuators
Loss Compensation	34.0	L0	Off	N	Y	N	On	On	On	Loss Compensation
	34.1	L1	On	Y	Y	N	Off	Off	Off	
	34.2	LA	Enter Loss before DUT in dB	N	Y	N	NC	0 dB	0 dB	
	34.3	LT	Enter Temperature of Losses	N	Y	N	NC	0K	0K	
34.4	LB	Enter Loss after DUT in dB	N	Y	N	NC	0 dB	0 dB		
Sequence Functions	35.0	QM	Manual	N	N	N	On	On	On	Sequence
	35.1	QA	Automatic	N ²	N	N	Off	Off	Off	
	35.2	QS	Set	N	Y	N	NC	1-9	1-9	
	35.3	QC	Clear	N	N	N	Off	Off	Off	
Noise Figure Test Set YIG Filter Fine Tuning Calibration	36.0	FT	Enable Fine Tuning Calibration before Noise Figure Measurement System Cal. (Error E28 enabled.)	N	Y	Y	On	On	On	Noise Figure Test Set YIG Filter Calibration
	36.1	FD	Disable Fine Tuning Calibration before Noise Figure Measurement System Calibration is done.	N	Y	Y	Off	Off	Off	
	36.2	FW	Disable Fine Tuning Calibration before Noise Figure Measurement System Calibration is done. Also, error twenty-eight is disabled.	Y	Y	Y	Off	Off	Off	
	36.3	PF	Perform a Fine Tuning Calibration from START FREQ to STOP FREQ and enable Special Function 36.1.	N	N	N	Off	Off	Off	
	36.4	FF	Enable a Fine Tuning Calibration at the current frequency	N	N	N	Off	Off	Off	
<p>*Most Special Functions can be programmed using either the code number followed by SP or the HP-IB Code. N = No; Y = Yes; NC = No Change; -- = Not Applicable</p>										

¹IF Attenuators Calibration; Special Function 33.1 (HP-IB Code CI). IF Special Function 33.1 is used, the gain accuracy specification will be degraded from 0.15 dB to a typical value of 0.25 dB. For more information, refer to the Calibration, IF Attenuators Detailed Operating Instruction.

²Enables Special Function Key LED to light when SEQ is pressed.

Table 3-14. Special Function Summary (7 of 15)

Special Function		Program Code HP-IB	Description	Lights Special Function Key	Stored in Continuous Memory	Can be Stored and Recalled	Special Function 0.0 Conditions	Preset (and HP-IB Clear) Conditions	Special Function 0.9 Conditions	References and Comments
Name	Code*									
Interpolated Measurements	39.0	DG	Disables interpolated measurements in Measurement Modes 1.5 to 1.9	N	Y	Y	NC	On	On	Calibration
	39.1	EG	Enables interpolated measurements in Measurement Modes 1.5 to 1.9	N	Y	Y	NC	Off	Off	
HP-IB and SIB Addresses	40.0	none	Display and Enter Noise Figure Meter Address	N	Y	N	NC	NC	8	HP-IB and SIB Addresses
	40.1	EA	Display and Enter Sys. LO Address	N	Y	N	NC	NC	19	
	40.2	HT	Display and Enter Noise Figure Test Set Address	N	Y	N	NC	NC	10	
	40.3	HP	Display and Enter Plotter Address	N	Y	N	NC	NC	5	
	40.4	HS	Display and Enter System Interface Bus Address	N	Y	N	NC	NC	8	
	40.5	HC	Display and Enter the Pass Control Address	N	Y	N	NC	NC	16	
	40.6	PT	Display and Enter the Address of the Pass Through Device on the System Interface Bus	N	Y	N	NC	0 ¹	0 ¹	
	40.7	VP	Display the Pass Through Address of the Noise Figure Meter	N	N	N	NC	NC	NC	
System LO Programs	41.0	J0	HP 8350B Sweep Oscillator	N	Y	N	NC	NC	On	Programs Available to Control the System LO
	41.2	J2	HP 8671B/8672A Syn. Signal Generator	N	Y	N	NC	NC	Off	
	41.3	J3	HP 8673B/C Syn. Signal Generator	N	Y	N	NC	NC	Off	
	41.4	J4	HP 8340B/8341B Sweep Oscillator	N	Y	N	Off	Off	Off	
	41.5	J5	Custom Local Oscillator	N	Y	N	Off	Off	Off	
<p>*Most Special Functions can be programmed using either the code number followed by SP or the HP-IB Code. N = No; Y = Yes; NC = No Change; — = Not Applicable</p>										

¹Also, Pass Through Mode is disabled.

Table 3-14. Special Function Summary (8 of 15)

Special Function		Program Code HP-IB	Description	Lights Special Function Key	Stored in Continuous Memory	Can be Stored and Recalled	Special Functions 0.0 Conditions	Preset (and HP-IB Clear) Conditions	Special Function 0.9 Conditions	References and Comments
Name	Code*									
System LO Commands	42.0	AC	Auxilliary Commands	N	Y	Y	NC	NC	0	Programming the System LO
	42.1	PS	CW Prefix and Suffix	N	Y	N	NC	NC	CW,MZ	
	42.2	TM	Settling Time in ms	N	Y	N	NC	NC	60	
	42.3	MN	Min Frequency in MHz	N	Y	N	NC	NC	2 000	
	42.4	MX	Max Frequency in MHz	N	Y	N	NC	NC	26 500	
	42.5	PL	Power level in dBm	N	Y	Y	NC	NC	6 dBm	
	42.6	PC	Power Prefix and Suffix (Special Function 41.5)	N	Y	N	NC	NC	NC	
	42.7	FC	Frequency Prefix and Suffix (Special Function 41.5)	N	Y	N	NC	NC	NC	
HP-IB Data Output Selection	43.0	H0	NOISE FIGURE Only	N	N	N	On	On	On	Refer to Remote Operation, Hewlett-Packard Interface Bus
	43.1	H1	Frequency (left display), INSERTION GAIN, NOISE FIGURE	N	N	N	Off	Off	Off	
	43.2	H2	Send gain reference and second stage temperature, while calibrating.	N	N	N	Off	Off	Off	
Service Request	44.0	Q0	Disable SRQ Capability (clears all enabled conditions)	N	N	N	Off	Off	Off	Refer to Remote Operations, Hewlett-Packard Interface Bus
	44.1	Q1	Enable Data Ready to cause an SRQ	N	N	N	Off	Off	Off	
	44.2	Q2	Enable Cal Complete to cause an SRQ	N	N	N	Off	Off	Off	
	44.3	Q3	Enable HP-IB Code Error to cause an SRQ	N	N	N	On	On	On	
	44.4	Q4	Enable SRQ on the System Interface Bus	N	N	N	Off	Off	Off	
	44.5	Q5	Enable System Interface Bus control active	N	N	N	Off	Off	Off	
	44.6	Q6	Enable Instrument Error to cause an SRQ	N	N	N	Off	Off	Off	
	44.7	RM	Set Status Byte Mask	N	N	N	4	4	4	
<p>*Most Special Functions can be programmed using either the code number followed by SP or the HP-IB Code. N = No; Y = Yes; NC = No Change; -- = Not Applicable</p>										

Table 3-14. Special Function Summary (9 of 15)

Special Function		Program Code HP-IB	Description	Lights Special Function Key	Stored in Continuous Memory	Can be Stored and Recalled	Special Function 0.0 Conditions	Preset (and HP-IB Clear) Conditions	Special Function 0.9 Conditions	References and Comments
Name	Code*									
Service Request (cont'd)	44.8	Q8	Enable Extended Status Byte	N	N	N	Off	Off	Off	
	44.9	RE	Set Extended Status Byte Mask	N	N	N	0	0	0	
Noise Figure Test Set Control	45.0	TE	Enable Noise Figure Test Set in Modes 1.5 — 1.9	N	Y	N	NC	NC	On	System Interface Control
	45.1	TS	Enable Noise Figure Test Set on SIB in all Modes	N	Y	N	NC	NC	Off	
	45.2	TD	Disable Noise Figure Test Set on SIB	N	Y	N	NC	NC	Off	
System Local Oscillator Control	46.0	LE	Enable LO on SIB	N	Y	N	NC	NC	On	SIB Control
	46.1	LD	Disable LO on SIB	N	Y	N	NC	NC	Off	
Plotter and HP 8757 Scalar Analyzer Control on SIB	47.0	PI	Plotter is on SIB	N	Y	N	NC	NC	On	Data Output to Oscilloscopes, Recorders and Plotters and SIB Control
	47.1	PM	Enable plot data to be read on HP-IB	N	Y	N	NC	NC	Off	
	47.2	ZP	Enable Scalar Analyzer commands on SIB	N	N	N	On	On	On	
	47.3	ZQ	Disable Scalar Analyzer commands on SIB	N	N	N	Off	Off	Off	
	47.4	ZR	Display and enter Scalar Analyzer SIB address	N	N	N	NC	16	16	
	47.5	ZS	Enter measurement frequencies per Scalar Analyzer display refresh	N	N	N	NC	0	0	
SIB Controller	48.0	SC	Noise Figure Meter is System Controller on SIB	N	Y	N	NC	NC	On	SIB Control
	48.1	NC	Noise Figure Meter is not System Controller on SIB	N	Y	N	NC	NC	Off	
	48.2	DC	Disable controller collision, on SIB, error (E48)	N	Y	N	NC	Off	Off	

*Most Special Functions can be programmed using either the code number followed by SP or the HP-IB Code.
N = No; Y = Yes; NC = No Change; — = Not Applicable

Table 3-14. Special Function Summary (10 of 15)

Special Function		Program Code HP-IB	Description	Lights Special Function Key	Stored in Continuous Memory	Can be Stored and Recalled	Special Functions 0.0 Conditions	Preset (and HP-IB Clear) Conditions	Special Function 0.9 Conditions	References and Comments
Name	Code*									
Sharing Control on the System Interface Bus	49.0	DP	Disable Auto Pass Control on the System Interface Bus	N	Y	N	NC	NC	On	System Interface Control
	49.1	EP	Enable Auto Pass Control on the System Interface Bus	N	Y	N	NC	NC	Off	
	49.2	CR	Noise Figure Meter releases control of the System Interface Bus	N	N	N	NC	NC	Off	
	49.3	CT	Noise Figure Meter takes control of the System Interface Bus	N	N	N	NC	NC	Off	
	49.4	SB	Noise Figure Meter does a serial poll on the System Interface Bus	N	N	N	NC	NC	Off	
	49.5	DD	Enable a selective device clear of the Pass Through Device on the System Interface Bus	N	N	N	Off	Off	Off	
	49.6	DS	Enable a device clear on the System Interface Bus, if the Noise Figure Meter is the active controller	N	N	N	Off	Off	Off	
	49.7	IS	Enable an interface clear on the System Interface Bus, if the Noise Figure Meter is the system controller	N	N	N	Off	Off	Off	
Special Function Catalog	50.0	G0	Scan Special Function Catalog Lines	N	N	N	Off	Off	Off	Special Function Catalog
	50.1	G1	Line 1 Status	N	N	N	Off	Off	Off	
	50.2	G2	Line 2 Status	N	N	N	Off	Off	Off	
	50.3	G3	Line 3 Status	N	N	N	Off	Off	Off	
	50.4	G4	Line 4 Status	N	N	N	Off	Off	Off	
	50.5	G5	Line 5 Status	N	N	N	Off	Off	Off	
<p>*Most Special Functions can be programmed using either the code number followed by SP or the HP-IB Code. N = No; Y = Yes; NC = No Change; — = Not Applicable</p>										

Table 3-14. Special Function Summary (11 of 15)

Special Function		Program Code HP-IB	Description	Lights Special Function Key	Stored in Continuous Memory	Can be Stored and Recalled	Special Functions 0.0 Conditions	Preset (and HP-IB Clear) Conditions	Special Function 0.9 Conditions	References and Comments
Name	Code*									
Special Function Catalog (cont'd)	50.6	G6	Line 6 Status	N	N	N	Off	Off	Off	
	50.7	G7	Line 7 Status	N	N	N	Off	Off	Off	
	50.8	G8	Line 8 Status	N	N	N	Off	Off	Off	
RF Attenuation Selection	60.0	R0	Auto	N	N	N	On	On	On	RF Attenuation Selection
	60.1	R1	+20 dB	Y	N	N	Off	Off	Off	
	60.2	R2	+10 dB	Y	N	N	Off	Off	Off	
	60.3	R3	0 dB	Y	N	N	Off	Off	Off	
	60.4	R4	-10 dB	Y	N	N	Off	Off	Off	
	60.5	R5	-20 dB	Y	N	N	Off	Off	Off	
	60.6	R6	-30 dB	Y	N	N	Off	Off	Off	
Display RF Attenuator Settings	61.0	SR	Display RF Attenuators	N	N	N	Off	Off	Off	RF Attenuation Selection
RF Attenuator Hold	62.0	RH	RF Attenuators are held in the configuration that exists when Special Function 62.0 is activated	Y	N	N	Off	Off	Off	RF Attenuation Selection
Individual RF Attenuator Selection	63.0	Z0	Select RF through Path	Y	N	N	Off	Off	Off	RF Attenuation Selection Refer to Section VIII, Service ¹
	63.1	Z1	Select 10 dB Pad Number 1	Y	N	N	Off	Off	Off	
	63.2	Z2	Select 20 dB Input Amplifier	Y	N	N	Off	Off	Off	
	63.4	Z4	Select 10 dB Pad Number 2	Y	N	N	Off	Off	Off	
	63.5	Z5	Select 10 dB Pad Number 3	Y	N	N	Off	Off	Off	
<p>*Most Special Functions can be programmed using either the code number followed by SP or the HP-IB Code. N = No; Y = Yes; NC = No Change; -- = Not Applicable</p>										

¹Section VIII, Service, is in the Service Manual. The part number of the Service Manual is on the title page of this manual.

Table 3-14. Special Function Summary (12 of 15)

Special Function		Program Code HP-IB	Description	Lights Special Function Key	Stored in Continuous Memory	Can be Stored and Recalled	Special Functions 0.0 Conditions	Preset (and HP-IB Clear) Conditions	Special Function 0.9 Conditions	References and Comments
Name	Code*									
Noise Figure Test Set YIG Filter Coarse Calibration	64.0	CP	Enable a coarse calibration of the Noise Figure Test Set	N	N	N	NC	NC	Off	Noise Figure Test Set YIG Filter Calibration
	64.1	CU	Selects the upper frequency of the Noise Figure Test Set	N	N	N	NC	NC	Off	
IF Attenuation Selection	70.0	I0	Auto	N	N	N	On	On	On	IF Attenuation Selection
	70.1	I1	0 db	Y	N	N	Off	Off	Off	
	70.2	I2	5 db	Y	N	N	Off	Off	Off	
	70.3	I3	10 db	Y	N	N	Off	Off	Off	
	70.4	I4	15 db	Y	N	N	Off	Off	Off	
	70.5	I5	20 db	Y	N	N	Off	Off	Off	
	70.6	I6	25 db	Y	N	N	Off	Off	Off	
	70.7	I7	30 db	Y	N	N	Off	Off	Off	
70.8	I8	35 db	Y	N	N	Off	Off	Off		
Display IF Attenuator Settings	71.0	SI	Display IF Attenuators	N	N	N	Off	Off	Off	IF Attenuation Selection
IF Attenuator Hold	72.0	IH	IF Attenuators are held in the configuration that exists when Special Function 72.0 is activated	Y	N	N	Off	Off	Off	IF Attenuation Selection
Voltmeter Mode	80.0	VC	Noise Source Off	N	Y	Y	Off	Off	Off	Refer to Section VIII, Service ¹
	81.0	VH	Noise Source On	N	Y	Y	Off	Off	Off	
Recorder Test Functions	82.0	A7	Enable Recorder Test	N	N	N	Off	Off	Off	Refer to Section VIII, Service ¹
	82.1	XV	X-Axis Test	N	N	N	NC	0	0	
	82.2	YV	Y-Axis Test	N	N	N	NC	0	0	
<p>*Most Special Functions can be programmed using either the code number followed by SP or the HP-IB Code. N = No; Y = Yes; NC = No Change; — = Not Applicable</p>										

¹Section VIII, Service, is in the Service Manual. The part number of the Service Manual is on the title page of this manual.

Table 3-14. Special Function Summary (13 of 15)

Special Function		Program Code HP-IB	Description	Lights Special Function Key	Stored in Continuous Memory	Can be Stored and Recalled	Special Functions 0.0 Conditions	Preset (and HP-IB Clear) Conditions	Special Function 0.9 Conditions	References and Comments
Name	Code*									
Keyboard Test	90.0	KY	Display Key Codes	N	N	N	Off	On	Off	Refer to Section VIII, Service ¹
	90.1	K1	Key Test—Row 1	N	N	N	Off	On	Off	
	90.2	K2	Key Test—Row 2	N	N	N	Off	On	Off	
	90.3	K3	Key Test—Row 3	N	N	N	Off	On	Off	
	90.4	K4	Key Test—Row 4	N	N	N	Off	On	Off	
	90.5	K5	Key Test—Row 5	N	N	N	Off	On	Off	
	90.6	K6	Key Test—Row 6	N	N	N	Off	On	Off	
	90.7	K7	Key Test—Row 7	N	N	N	Off	On	Off	
	90.8	K8	Key Test—Row 8	N	N	N	Off	On	Off	
Display Test	91.0	DT	Enable Display Test	N	N	N	Off	Off	Off	Refer to Section VIII, Service ¹
0 MHz Hold	92.0	U0	Off	N	N	N	On	On	On	Refer to Section VIII, Service ¹
	92.1	U1	On	Y	N	Y	Off	Off	Off	
RAM Inspection/Modification or ROM Inspection Utilities	93.0	AI	Sets the address for modification or inspection and enables auto-increment mode	N	N	N	NC	Cal Data	Cal Data	Refer to Section VIII, Service ¹
	93.1	AD	Sets the address for modification or inspection and disables auto-increment mode	N	N	N	NC	Cal Data	Cal Data	
	93.2	MB	Selects modification or inspection of a byte in RAM or inspection of a byte in ROM	N	N	N	Off	Off	Off	
	93.3	MW	Selects modification or inspection of a word in RAM or inspection of a word in ROM	N	N	N	Off	Off	Off	
	93.4	MF	Selects modification or inspection of a floating point value in RAM or inspection of a floating point value in ROM	N	N	N	Off	Off	Off	
<p>*Most Special Functions can be programmed using either the code number followed by SP or the HP-IB Code. N = No; Y = Yes; NC = No Change; — = Not Applicable</p>										

¹Section VIII, Service, is in the Service Manual. The part number of the Service Manual is on the title page of this manual.

Table 3-14. Special Function Summary (14 of 15)

Special Function		Program Code HP-IB	Description	Lights Special Function Key	Stored in Continuous Memory	Can be Stored and Recalled	Special Function 0.0 Conditions	Preset (and HP-IB Clear) Conditions	Special Function 0.9 Conditions	References and Comments
Name	Code*									
Noise Figure Meter YIG Filter Tuning Functions	94.1	—	Disable hysteresis calibration when frequency is changed	N	N	N	Off	Off	Off	Refer to Section VIII, Service ¹
	94.2	EH	Enable hysteresis calibration when frequency is changed	N	N	N	On	On	On	
	94.3	—	YIG DAC is not updated when frequency is changed	N	N	N	Off	Off	Off	
	94.4	UY	YIG DAC is updated when frequency is changed	N	N	N	On	On	On	
Default ENR	95.6	ND	Sets all ENR values to 15.20 dB and Noise Source ID No. to 00000	N	N	N	Off	Off	Off	Refer to Section VIII, Service ¹
User Controlled LO Functions	96.0	—	Disables LO commands on the System Interface Bus (SIB).	N	Y	N	NC	NC	On	System Interface Bus Control
	96.1	—	Enables LO commands on the SIB.	N	Y	N	NC	NC	Off	System Interface Bus Control
	96.2	—	User Controlled LO SIB Address	N	Y	N	NC	NC	20	HP-IB and SIB Addresses
	96.3	—	User Controlled LO Program; 0=same used by system LO; 1=custom LO program	N	Y	N	NC	NC	0	Measurement Modes 1.6–1.9 Comments section
Debug Oscilloscope Plots	97.1	Y9	Enables debug oscilloscope plots	N	N	N	NC	Off	Off	Refer to Section VIII, Service ¹
	97.2	Y8	Disable debug oscilloscope plots	N	N	N	NC	On	On	
Noise Figure Test Set Functions	97.3	DA	Disable auto-sweep abort, error E102.	N	Y	Y	Off	Off	Off	Refer to Section VIII, Service ¹
	97.4	—	Reset Noise Figure Test Set YIG Filter Heater.	N	N	N	Off	Off	Off	Refer to the HP 8971B Service Manual
<p>*Most Special Functions can be programmed using either the code number followed by SP or the HP-IB Code. N = No; Y = Yes; NC = No Change; — = Not Applicable</p>										

¹Section VIII, Service, is in the Service Manual. The part number of the Service Manual is on the title page of this manual.

Table 3-14. Special Function Summary (15 of 15)

Special Function		Program Code HP-IB	Description	Lights Special Function Key	Stored in Continuous Memory	Can be Stored and Recalled	Special Functions 0.0 Conditions	Preset (and HP-IB Clear) Conditions	Special Function 0.9 Conditions	References and Comments
Name	Code*									
Hewlett-Packard Interface Bus and System Interface Bus Test	98.1	—	Enable HP-IB and SIB test	N	N	N	Off	Off	Off	Refer to Section VIII, Service ¹
Noise Figure Meter RAM Test	98.2	—	Enable RAM test.	N	N	N	Off	Off	Off	Refer to Section VIII, Service ¹
Noise Figure Test Set Self Test	98.7	—	Enable Noise Figure Test Set Self Test	N	N	N	Off	Off	Off	Refer to Section VIII, Service ¹
Last Error	99.1	ER	Recall last error issued	N	N	N	Off	Off	Off	Refer to Section VIII, Service ¹
Noise Figure Test Set Firmware Datecode	99.7	—	Display Noise Figure Test Set Firmware Datecode	N	N	N	Off	Off	Off	Refer to Section VIII, Service ¹
Noise Figure Meter Firmware Datecode	99.9	SD	Display Noise Figure Meter Firmware Datecode	N	N	N	Off	Off	Off	Refer to Section VIII, Service ¹

*Most Special Functions can be programmed using either the code number followed by SP or the HP-IB Code.
N = No; Y = Yes; NC = No Change; — = Not Applicable

¹Section VIII, Service, is in the Service Manual. The part number of the Service Manual is on the title page of this manual.

Spot ENR, T_{hot} , T_{cold} and ENR Table Selection (Special Functions 5 and 6)

Description

Special Functions 5 and 6 perform the following functions:

a. Special Function 5.0 enables use of the ENR (Excess Noise Ratio) data that was previously entered (refer to the ENR Table Entry Detailed Operating Instruction). This function disables spot ENR. (Spot ENR can be re-enabled using Special Function 5.1).

b. Special Function 5.1 enables use of the previously entered spot ENR value (refer to Special Function 5.3). The ENR table is disabled and the single spot ENR value will be used at all frequencies. (The ENR table can be re-enabled using Special Function 5.0).

c. Special Function 5.2 enables the current value of ENR being used by the instrument to be displayed.

d. Special Function 5.3 enables entry and use of a spot ENR value. The allowable values for spot ENR range from -7 to $+17$ dB.

e. Special Function 5.4 enables entry and use of T_{hot} . Some noise sources are specified in terms of T_{hot} instead of ENR. The allowable values for T_{hot} (in Kelvins) range from 0 to 14824. The equation to convert T_{hot} (in Kelvins) to ENR is:

$$\text{ENR} = 10 \log (T_{\text{hot}}/290 - 1)$$

f. Special Function 5.5 enables display and entry of the noise source identifier. Up to five digits, within the range of 0 to 60000 can be used to identify the noise source. For example, the serial number of the noise source for which the ENR table data was entered can be used.

g. Special Function 5.6 enables display of the noise source catalog. The noise source catalog special function allows the user to examine each of the ENR tables; the user is able to see how many entries are in each table.

h. Special Function 5.7 allows display and entry of the ENR table that will be used for calibration. Tables 0 through 4 can be selected for a calibration. Special Function 5.7 is useful in Measurement Modes 1.3, 1.4, 1.8 and 1.9, where two noise sources may be required.

i. Special Function 5.8 allows display and entry of the ENR table that will be used for a measurement. Tables 0 through 4 can be selected for the measurement.

j. Special Function 6.0 enables entry of a value for T_{cold} . T_{hot} and T_{cold} are used for hot/cold manual measurements. The allowable values for T_{cold} (in Kelvins) range from 0 to 9999.

Procedure

To enable use of the ENR table data or spot ENR data, or to display the current ENR or noise source catalog, key in the corresponding Special Function code and then press the SPECIAL FUNCTION key.

To display and enable entry of spot ENR, T_{hot} , T_{cold} , the noise source identifier, the ENR table number for calibration or the ENR table number for a measurement, key in the corresponding Special Function code and then press the SPECIAL FUNCTION key. Next, enter the appropriate value using the DATA keys and press ENTER.

Spot ENR, T_{hot} , T_{cold} and ENR Table Selection (cont'd)

(Special Functions 5 and 6)

**Procedure
(cont'd)**

Special Function		Program Code HP-IB	Lights Special ¹ Function Key	Stored in Con- tinuous Memory	Can be Stored and Recalled	Special Function 0.0 Conditions	Preset (and HP-IB Clear) Conditions	Special Function 0.9 Conditions
Description	Code							
Use ENR Table Data	5.0	S0 or 5.0SP	N	Y	Y	On	On	On
Use Spot ENR Data	5.1	S1 or 5.1 SP	Y	Y	Y	Off	Off	Off
Display Current ENR in dB	5.2	SE or 5.2SP	N	N	N	Off	Off	Off
Enter and Use Spot ENR	5.3	NE or 5.3SP	N	Y	Y	NC	15.2 dB	15.2 dB
Enter and Use T_{hot}	5.4	TH or 5.4SP	N	Y	Y	NC	9893K	9893K
Enter Noise Source Identifier	5.5	SN or 5.5SP	N	Y	N	NC	NC	NC
Noise Source Catalog	5.6	NS or 5.6SP	N	N	N	NC	NC	NC
ENR Table for Calibration	5.7	EC or 5.7SP	N	Y	Y	NC	0	0
ENR Table for Measurement	5.8	EM or 5.8SP	N	Y	Y	NC	0	0
Enter T_{cold}	6.0	TC or 6.0SP	N	Y	Y	NC	296.5K	296.5K

¹Table categories are explained in the Special Functions Detailed Operating Instruction.

Example

To enter and use a value of 9800K for T_{hot} (assuming Special Function 11.0 is active).

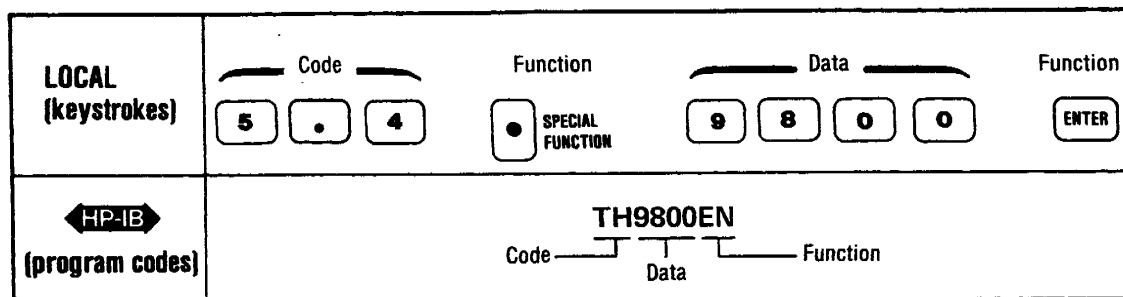

Program Codes



For HP-IB codes for Special Functions 5 and 6, refer to Procedure above. The program code for ENTER is EN.

Indications

When Special Function 5.2 or 5.3 is active, the current ENR or spot ENR is shown in the left display in units of dB. If a new spot ENR value is entered, it appears in the left display for as long as the ENTER key is depressed.

When Special Function 5.4 or 6.0 is active, T_{hot} or T_{cold} is shown in the left display in the temperature unit selected by Special Function 11. If a new value is entered for either T_{hot} or T_{cold} , it appears in the left display for as long as the ENTER key is depressed.

Spot ENR, T_{hot} , T_{cold} and ENR Table Selection (cont'd)

(Special Functions 5 and 6)

Indications (cont'd)

When Special Function 5.5 is active, the left display shows five digits. No units are displayed.

When Special Function 5.6 is active, the left display shows the ENR identification number of one of the ENR tables. The right display shows the ENR table number and the number of entries in the table.

When Special Function 5.7 or 5.8 is active, the left display shows the number of the table that is currently being used for calibration or measurement. If a new table number is entered for calibration or measurement, it appears in the left display for as long as the ENTER key is depressed.

Related Sections

ENR Table Entry
Manual Measurement Functions
Special Functions
Temperature Units Selection

Store and Recall

Description Up to ten instrument configurations can be stored in the Noise Figure Meter's storage registers. Front panel settings that are stored and recalled are FREQUENCY, FREQ INCR, START FREQ, STOP FREQ, and STEP SIZE. Table 3-14, Special Function Summary, in the Special Functions Detailed Operating Instruction has a complete listing of special functions that can and cannot be stored and recalled.

Procedure Press STORE and a Data key (a single digit 0-9 to identify the storage register).
Press RECALL and a Data key (a single digit 0-9 to identify the storage register).

Example To recall an instrument configuration that has been stored in register 2:

LOCAL (keystrokes)	<table border="0"> <tr> <td style="text-align: center;">Function</td> <td style="text-align: center;">Data</td> </tr> <tr> <td style="text-align: center;">RECALL</td> <td style="text-align: center;">2</td> </tr> </table>	Function	Data	RECALL	2
Function	Data				
RECALL	2				
 (program codes)	<table border="0"> <tr> <td colspan="2" style="text-align: center;">RC2</td> </tr> <tr> <td style="text-align: center;">Code</td> <td style="text-align: center;">Data</td> </tr> </table>	RC2		Code	Data
RC2					
Code	Data				

Program Codes



Key	Program Code 
STORE RECALL	ST RC

Indications When the stored contents of a register are recalled, the instrument configuration changes to the recalled parameter values.

Comments If any key other than a digit is pressed after STORE or RECALL, the store or recall entry will be rejected.

The data in the storage registers is not affected by PRESET or Special Function 0.0.

When the Noise Figure Meter is turned off, data stored in the registers is retained.

Related Sections Preset Conditions and Power-Up Sequence
Sequence
Special Functions

Sweep

Description

The Noise Figure Meter (Noise Figure Measurement System) can sweep the measurement frequency from START FREQ to STOP FREQ. The frequency changes in discrete steps (as set by STEP SIZE) rather than in a continuous analog manner.

The allowable sweep range depends on the measurement mode selected.

Measurement Mode	Range of Sweep	Conditions
1.0	10 to 1600 MHz 2047 MHz, opt 020	
1.1	1 to 99999 MHz	Depends on the frequency range of the system LO and the noise source.
1.2	>10 to <1600 MHz 2047 MHz, opt 020	System LO must be set up so that variable IF sweeps 10 to 1600 MHz (2047 MHz, opt 020)
1.3	1 to 99999 MHz	Depends on the frequency range of the system LO and the noise source.
1.4	10 to 1600 MHz 2047 MHz, opt 020	IF port response of mixer is being measured. Left display shows IF.
1.5	10 to 26500 MHz	
1.6	1 to 99999 MHz	Depends on frequency range of user controlled local oscillator and the noise source.
1.7	10 to 26500 MHz	User controlled local oscillator must be set up so that variable IF sweeps 10 to 26500 MHz
1.8	1 to 99999 MHz	Depends on frequency range of user controlled local oscillator and the noise source.
1.9	10 to 26500 MHz	IF port response of mixer is being measured. Left display shows IF.

Depending on the Measurement Mode selected, the START FREQ, STOP FREQ and STEP SIZE default to different values. The following table lists the default frequencies for the Measurement Modes.

Measurement Modes	START FREQ	STOP FREQ	STEP SIZE
1.0 and 1.4	10 MHz	1600 MHz	20 MHz
1.1, 1.2 and 1.3	8000 MHz	12000 MHz	200 MHz
1.5 and 1.9	10 MHz	26500 MHz	250 MHz
1.6, 1.7 and 1.8	45000 MHz	50000 MHz	500 MHz

Sweep (cont'd)

Description (cont'd)

As shown in the table, the Measurement Modes have been placed into four groups. When the start, stop and step size frequencies are changed for one measurement mode, the start, stop and step size frequencies are changed for all the measurement modes of the group. When selecting a new Measurement Mode, the Noise Figure Meter automatically saves the start, stop and step size frequencies from the previous measurement mode.

The minimum step size is 1 MHz. The maximum number of frequency points allowable in one sweep is

$$\frac{\text{STOP FREQ} - \text{START FREQ}}{\text{STEP SIZE}} + 1$$

If the fractional part of

$$\frac{\text{STOP FREQ} - \text{START FREQ}}{\text{STEP SIZE}} + 1$$

does not equal 0, then add 1.

However, the maximum number of frequency points that should be used when the sweep is displayed on an oscilloscope is 251. If more points are swept, multiple readings could occur at some points. Other limitations may be caused by the system LO.

Two sweep modes are available: Auto and Single. Each mode uses the sweep parameters that were previously set. Auto mode executes a repetitive sweep, restarting at the end of each sweep. Single mode executes one sweep only. At the end of a single sweep, the instrument remains tuned to the stop frequency.

Procedure

Sweep Range Selection. The START FREQ and STOP FREQ keys set the starting and stopping points of the frequency sweep. STEP SIZE sets the frequency increment. Sweep parameters are selected in a Function - Data - ENTER format. Note that all frequency inputs from the front panel are in MHz.

Sweep Mode Selection. Press the desired mode key (AUTO or SINGLE) to initiate a sweep. To turn a sweep off, press the active sweep mode key a second time.

Front Panel Key	Program Code HP-IB	Stored in Continuous Memory ¹	Can be Stored and Recalled	Preset (and HP-IB Clear) Conditions	Special Function 0.9 Conditions
AUTO	W1	N	N	Off	Off
SINGLE	W2	N	N	Off	Off
START FREQ	FA	Y	Y	10 MHz	10 MHz
STEP SIZE	SS	Y	Y	20 MHz	20 MHz
STOP FREQ	FB	Y	Y	1600 MHz	1600 MHz

¹ Table categories are explained in the Preset Conditions and Power-Up Sequence Detailed Operating Instruction.

Sweep (cont'd)

Example

To sweep from 100 MHz to 400 MHz in 50 MHz steps once only:

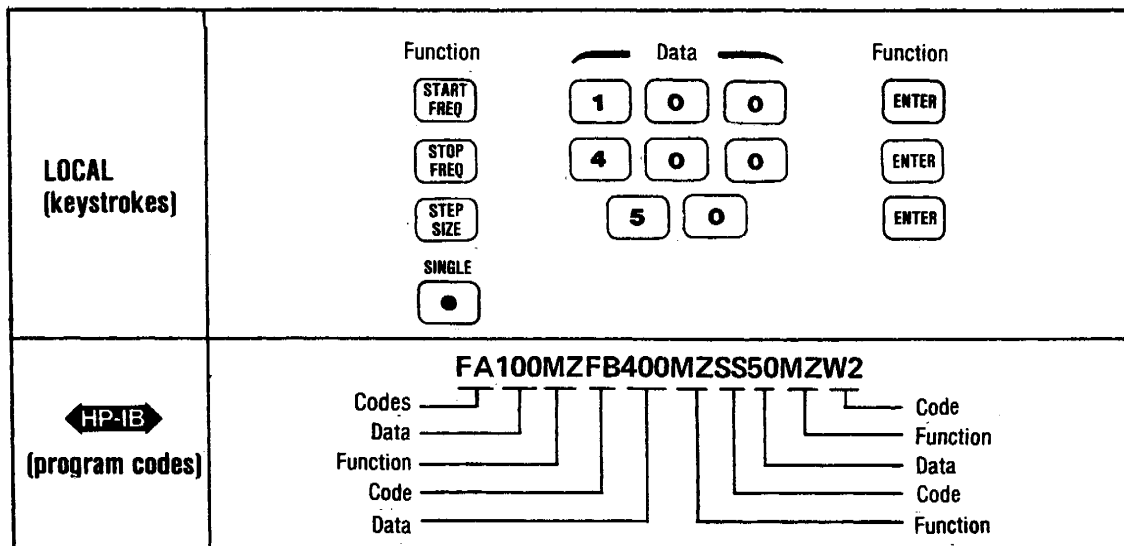

Program Codes
HP-IB

Parameter	Program Code HP-IB
Hz	HZ
MHz	MZ
Sweep Off	W0

For additional HP-IB program codes, refer to Procedure above.

Indications

When the START FREQ or STOP FREQ key is pressed, the left display shows the currently programmed start or stop frequency. The instrument tunes to that frequency and continues measuring there. As a new start or stop frequency is entered, it appears in the left display. When the STEP SIZE key is pressed, the left display shows the step size only for as long as the key is held down. A newly entered value is displayed for as long as the ENTER key is held down.

When the AUTO or SINGLE key is pressed, the LED within the corresponding key lights to indicate that the instrument is in the sweep mode.

Comments

If the stop frequency is less than the start frequency, the instrument sweeps downward. The sweep is slower when it operates in this manner. However, calibration and plotting to an X/Y recorder must be performed in ascending frequency order only.

Pressing the AUTO key starts a sweep at the current frequency if the current frequency is not outside the start-stop range. If the current frequency is outside the start-stop range, the auto sweep starts at the programmed start frequency. To assure that an auto sweep starts at the programmed start frequency, press START FREQ, then AUTO.

Sweep (cont'd)

Comments (cont'd)

AUTO and SINGLE are toggle keys, and they stop the sweep when pressed a second time. However, program codes W1 and W2 do not toggle over the HP-IB. Use program code W0 to stop a sweep over the HP-IB.

Any front panel key except LOCAL, DECREASE, INCREASE, SPECIAL FUNCTION, NOISE FIGURE, and NOISE FIGURE AND GAIN stop the sweep when pressed.

All HP-IB codes except DE (DECREASE Smoothing), IN (INCREASE Smoothing), M1 (UNCORRECTED NOISE FIGURE), M2 (CORRECTED NOISE FIGURE and GAIN) and PT (Pass Through Mode) stop the sweep when given.

START FREQ, STOP FREQ, and STEP SIZE set the calibration parameters. During calibration, the maximum number of frequency points allowed in a sweep is 181.

If the last step of a sweep causes the frequency to exceed the programmed stop frequency, the Noise Figure Meter tunes a partial step to reach the programmed stop frequency.

HP-IB code W2 (single sweep) should be the last code given before a single sweep is triggered.

Related Sections

Calibrate
Measurement Modes 1.0 through 1.9

System Interface Bus Control

(Special Functions 45 through 49 and 96)

Description

The Noise Figure Meter has two IEEE 488.1 connectors, the Hewlett-Packard Interface Bus (HP-IB) and System Interface Bus (SIB). The System Interface Bus is actually an HP-IB port that the Noise Figure Meter uses to control such instruments as the system local oscillator, the user controlled local oscillator, a plotter and the Noise Figure Test Set. All instruments that the Noise Figure Meter can control are connected to the SIB connector. The external computer, used to control the Noise Figure Meter, is connected to the HP-IB connector. Also, connected to the HP-IB connector are any other instruments that the external computer needs to control, such as, the user controlled local oscillator, if it is not being controlled by the Noise Figure Meter, or other HP-IB devices.

When an instrument is connected to the SIB, a special function is used to enable or disable the Noise Figure Meter from sending that instruments commands, on the SIB. Special Functions 45 through 47 and 96 are used to control the HP 8971B/C Noise Figure Test Set (Special Function 45), system local oscillator (Special Function 46), plotter (Special Function 47), or the user controlled local oscillstor (Special Function 96).

The Noise Figure Meter has the capability of sharing control responsibilities with another instrument on the System Interface Bus. Special Function 49 deals with passing control between controllers on the System Interface Bus and control of the System Interface Bus. The Noise Figure Meter can be configured to the following Special Function 49 conditions:

- Special Function 49.0; do not pass control automatically.
- Special Function 49.1; pass control automatically.
- Special Function 49.2; release control of the SIB.
- Special Function 49.3; take control of the SIB.
- Special Function 49.4; perform a serial poll on the SIB.
- Special Function 49.5; perform a selective device clear of the pass through device.
- Special Function 49.6; perform a device clear on the SIB, if the Noise Figure Meter is the active controller.
- Special Function 49.7; perform an interface clear on the SIB, if the Noise Figure Meter is the system controller.

The structure of the System Interface Bus requires that one and ONLY one instrument be the system controller on the SIB. As called out in the IEEE 488.1 specification, "The system controller is defined as the device that controls the REN and IFC lines on an IEEE 488.1 interface." Special Function 48 conveys to the Noise Figure Meter if it will be the system controller (Special Function 48.0) or if the Noise Figure Meter will not be the system controller (Special Function 48.1).

Finally, the Noise Figure Meter has the capability of allowing an external computer, on the Hewlett-Packard Interface Bus, to gain control of an instrument on the System Interface Bus. The mode used is called Pass Through Mode. Pass Through Mode is described in the Example section of this instruction.

The following descriptions will give a better understanding of Special Functions 45 through 49 and 96:

- a. Special Function 45.0 enables the commands for the Noise Figure Test Set to be sent on the SIB in Measurement Modes 1.5 through 1.9.

System Interface Bus Control (cont'd)

(Special Functions 45 through 49 and 96)

Description (cont'd)

b. Special Function 45.1 enables the commands for the Noise Figure Test Set to be sent on the SIB in Measurement Modes 1.0 through 1.9. When Special Function 45.1 is active, the Noise Figure Test Set is set to bypass mode (SSB1) in Measurement Modes 1.0 through 1.4. This means that the measurement signal is passed straight through the Noise Figure Test Set, with only a 3 dB loss.

c. Special Function 45.2 disables the commands for the Noise Figure Test Set.

d. Special Function 46.0 enables the commands for the System Local Oscillator to be sent on the SIB in Measurement Modes 1.1 through 1.9.

e. Special Function 46.1 disables the commands for the System Local Oscillator in Measurement Modes 1.1 through 1.9.

f. Special Function 47.0 conveys to the Noise Figure Meter that the plotter is on the System Interface Bus. The use of Special Function 47.0 is described in the Data Output to Oscilloscopes, Recorders and Plotters Detailed Operating Instruction.

g. Special Function 47.1 conveys to the Noise Figure Meter that the plot data is to be read on the Hewlett-Packard Interface Bus (HP-IB). The use of Special Function 47.1 is described in the Data Output to Oscilloscopes, Recorders and Plotters Detailed Operating Instruction.

h. Special Function 48.0 enables the Noise Figure Meter to be the system controller on the System Interface Bus. Error forty-eight (E48) is generated if another controller has been enabled as controller on the System Interface Bus and Special Function 48 is active.

i. Special Function 48.1 conveys to the Noise Figure Meter that it is not the system controller on the System Interface Bus. This special function is useful if another controller is to share the System Interface Bus with the Noise Figure Meter.

j. Special Function 48.2 disables error forty-eight (E48). Error forty-eight occurs when the Noise Figure Meter has been told that it will be the controller on the System Interface Bus (Special Function 48.0) and the Noise Figure Meter detects another controller on the System Interface Bus. If this special function is to be used, ensure that the error condition does not exist. Check cabling carefully.

k. Special Function 49.0 disables auto-pass control. For instruments with auto-pass control capabilities, control is not automatically passed between the Noise Figure Meter and another controller.

l. Special Function 49.1 enables auto-pass control. For instruments with auto-pass control capabilities, control is automatically passed between the Noise Figure Meter and another controller. Control is passed automatically only if the pass control address (Special Function 40.5) has been set up previously.

m. Special Function 49.2 tells the Noise Figure Meter to release active control of the System Interface Bus. This special function is useful if control of the System Interface Bus is to be shared. Special Function 49.2 should be used before another controller is told to take control.

n. Special Function 49.3 tells the Noise Figure Meter to take active control of the System Interface Bus. Special Function 49.3 is only useful if there are more than two controllers on the System Interface Bus and control of the System Interface Bus is to be shared. This special function should be used after all other controllers have been told to release control of the System Interface Bus.

System Interface Bus Control (cont'd) (Special Functions 45 through 49 and 96)

**Description
(cont'd)**

o. Special Function 49.4 tells the Noise Figure Meter to do a serial poll on the System Interface Bus. The request is usually given by an external computer over the Hewlett-Packard Interface Bus, using the HP-IB code SB. For a serial poll program example, refer to the Comments section, at the end of this instruction.

p. Special Function 49.5 performs a selective device clear of the "pass through device" on the System Interface Bus. This task will be done before the next HP-IB read of the Noise Figure Meter can be done.

q. Special Function 49.6 performs a device clear on the System Interface Bus, if the Noise Figure Meter is the active controller. This task will be done before the next HP-IB read of the Noise Figure Meter can be done.

r. Special Function 49.7 performs an interface clear on the System Interface Bus, if the Noise Figure Meter is the system controller. All instruments on the System Interface Bus are unaddressed to listen or talk. This task will be done before the next HP-IB read of the Noise Figure Meter can be done.

s. Special Function 96.0 disables the commands for the User Controlled Local Oscillator from being sent on the SIB in Measurement Modes 1.6 through 1.9.

t. Special Function 96.1 enables the commands for the User Controlled Local Oscillator to be sent on the SIB in Measurement Modes 1.6 through 1.9.

u. Special Function 96.3 is used to let the Noise Figure Meter know which predefined program (Special Function 41) will be controlling the User Controlled Local Oscillator. Once Special Function 96.3 is active, a zero is entered if the System Local Oscillator and the User Controlled Local Oscillator will be controlled by the same predefined program. A one is entered if the User Controlled Local Oscillator will be controlled by the custom local oscillator program.

Procedure

To select one of the System Interface Bus Control special functions, key in the corresponding Special Function code and then press the SPECIAL FUNCTION key.

Special Function		Program Code HP-IB	Lights Special ¹ Function Key	Stored in Con- tinuous Memory	Can be Stored and Recalled	Special Function 0.0 Conditions	Preset (and HP-IB Clear) Conditions	Special Function 0.9 Conditions
Description	Code							
Enable Noise Figure Test Set in Measurement Modes 1.5 through 1.9	45.0	TE	N	Y	N	NC	NC	On
Enable Noise Figure Test Set in all Measurement Modes	45.1	TS	N	Y	N	NC	NC	Off
Disable Noise Figure Test Set in all Measurement Modes	45.2	TD	N	Y	N	NC	NC	Off

¹Table categories are explained in the Special Functions Detailed Operating Instruction.

System Interface Bus Control (cont'd)

(Special Functions 45 through 49 and 96)

Procedure
(cont'd)

Special Function		Program Code HP-IB	Lights Special ¹ Function Key	Stored in Con- tinuous Memory	Can be Stored and Recalled	Special Function 0.0 Conditions	Preset (and HP-IB Clear) Conditions	Special Function 0.9 Conditions
Description	Code							
Enable System Local Oscillator on the System Interface Bus	46.0	LE	N	Y	N	NC	NC	On
Disable System Local Oscillator on the System Interface Bus	46.1	LD	N	Y	N	NC	NC	Off
Plotter is on the System Interface Bus	47.0	PI	N	Y	N	NC	NC	On
Enable plot data to be on the Hewlett-Packard Interface Bus	47.1	PM	N	Y	N	NC	NC	Off
Enable Noise Figure Meter to be the system controller on the System Interface Bus	48.0	SC	N	Y	N	NC	NC	On
Disable Noise Figure Meter as the system controller on the System Interface Bus	48.1	NC	N	Y	N	NC	NC	Off
Disable error 48 (E48)	48.2	DC	N	N	N	NC	Off	Off
Disable auto-pass control	49.0	DP	N	Y	N	NC	NC	On
Enable auto-pass control	49.1	EP	N	Y	N	NC	NC	Off
Noise Figure Meter releases active control of the System Interface Bus	49.2	CR	N	N	N	Off	Off	Off
Noise Figure Meter takes active control of the System Interface Bus	49.3	CT	N	N	N	Off	Off	Off
Noise Figure Meter performs a serial poll on the System Interface Bus	49.4	SB	N	N	N	Off	Off	Off
Perform a selective device clear of the pass through device on the System Interface Bus	49.5	DD	N	N	N	Off	Off	Off

¹Table categories are explained in the Special Functions Detailed Operating Instruction.

System Interface Bus Control (cont'd)

(Special Functions 45 through 49 and 96)

Procedure
(cont'd)

Special Function		Program Code HP-IB	Lights Special ¹ Function Key	Stored in Con- tinuous Memory	Can be Stored and Recalled	Special Function 0.0 Conditions	Preset (and HP-IB Clear) Conditions	Special Function 0.9 Conditions
Description	Code							
Perform a device clear on the System Interface Bus, if the Noise Figure Meter is the active controller	49.6	DS	N	N	N	Off	Off	Off
Perform an interface clear on the System Interface Bus, if the Noise Figure Meter is the system controller	49.7	IS	N	N	N	Off	Off	Off
Disable the User Controlled LO on the System Interface Bus	96.0	—	N	Y	N	NC	NC	On
Enable the User Controlled LO on the System Interface Bus	96.1	—	N	Y	N	NC	NC	Off
Informs the Noise Figure Meter which pre-defined program will control the User Controlled Local Oscillator; 0=same as the System Local Oscillator; 1=custom local oscillator program	96.3	—	N	Y	N	NC	NC	0

¹Table categories are explained in the Special Functions Detailed Operating Instruction.

Example

To select the Noise Figure Meter as the controller on the System Interface Bus:

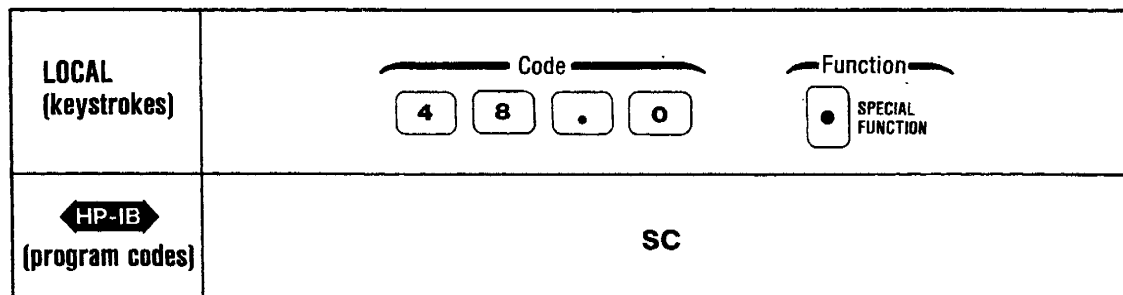

System Interface Bus Control (cont'd)

(Special Functions 45 through 49 and 96)

Procedure (cont'd)

The following examples will illustrate how the Noise Figure Meter can share control of the System Interface Bus (SIB) with another instrument on the SIB and how the Noise Figure Meter can be configured to pass commands from a computer on the Hewlett-Packard Interface Bus (HP-IB) to an instrument on the SIB.

Pass Through Mode

Pass Through Mode will allow commands to be “passed through” the Noise Figure Meter from an external computer, on the Hewlett-Packard Interface Bus (HP-IB), to an instrument on the System Interface Bus (SIB). The instrument on the SIB can be a listener or a talker. An SRQ (Service Request) on the SIB can trigger an SRQ on the HP-IB. Special Function 49.4 can be used to do a serial poll of an instrument on the SIB. Parallel poll will not be supported.

NOTE

When in Pass Through Mode the rate at which data is sent or received is slowed down. Typically data is sent at a rate of 0.5 ms/byte and received at a rate of 1.6 ms/byte. This is five and eight times, respectively, slower than if the instrument were connected directly to the external computer.

Pass Through Mode is set up as follows:

a. When the external computer wants to communicate with an instrument on the SIB, it sends the command PTdEN; d is the address of the instrument, on the SIB, that the computer wants to communicate with. The Noise Figure Meter will also accept the command PTd (carriage return; line feed) to be compatible with the HP 8757A Scalar Network Analyzer.

NOTE

The command PTdEN does not have to be sent each time a command is sent to the instrument on the SIB. The instrument on the SIB needs only to be specified once.

b. The external computer can now send commands to the instrument on the SIB. After Pass Through Mode is set up using PTdEN, the Noise Figure Meter has two addresses, its address and the pass through address. The pass through address is one greater than the Noise Figure Meter's address if the Noise Figure Meter's address is even and one less than the Noise Figure Meter's address if the Noise Figure Meter's address is odd. So, if the address of the Noise Figure Meter is eight (8) then the pass through address would be nine (9). If the address of the Noise Figure Meter is seven (7) then the pass through address would be six (6).

NOTE

The pass through address can be displayed by pressing 40.7 SPECIAL FUNCTION.

In Pass Through Mode two addresses are used up on the Hewlett-Packard Interface Bus (HP-IB). Ensure that an address is not used twice.

c. The external computer can send commands to a device on the SIB by using the Noise Figure Meter's pass through address. Commands can be sent to the Noise Figure Meter by using the Noise Figure Meter's HP-IB address.

System Interface Bus Control (cont'd)

(Special Functions 45 through 49 and 96)

Example (cont'd)

For example, if the external computer wanted to control the local oscillator on the SIB (at address 19) and the Noise Figure Meter's address is eight (8), the external computer may send the following commands:

OUTPUT 708; "PT19EN"	!This sets up the pass through !device address.
OUTPUT 709; "FR10000MZ"	!This command is sent to the !pass through address and then !to the local oscillator.

To get out of Pass Through Mode, simply, address the Noise Figure Meter or press the LOCAL key. Once the Noise Figure Meter is addressed, it is out of Pass Through Mode until the next time an output is done to the pass through address.

NOTE

Error 46 (E46) is generated if the instrument on the SIB is not found or the address of the instrument is incorrect.

If the Noise Figure Meter is addressed, all the instruments on the SIB are re-initialized to the state they were in before Pass Through Mode was enabled. To avoid the instruments from being re-initialized, Special Function 45.2 (disable Noise Figure Test Set), Special Function 46.1 (disable system local oscillator) and Special Function 96.0 (disable user controlled local oscillator) can be used before Pass Through Mode is enabled (PTdEN). When finished with Pass Through Mode, the appropriate special functions for the Noise Figure Test Set, system local oscillator and user controlled local oscillator should be enabled.

Passing Control On The System Interface Bus

The Noise Figure Meter has the capability of passing control to another instrument on the System Interface Bus. An external computer, on the Hewlett-Packard Interface Bus, determines which instrument will have control.

Instrument Configuration. The following minimum requirements are necessary for the Noise Figure Meter to be able to pass control on the System Interface Bus:

NOTE

The following steps must be done in the order given.

- a. Set the Noise Figure Meter's System Interface Bus address using Special Function 40.4. The default address of the System Interface Bus is eight (8).
- b. Set the address of the Noise Figure Meter using Special Function 40.0. The default address of the Noise Figure Meter is eight (8).
- c. Decide if the Noise Figure Meter or the other instrument will be the system controller. If the other instrument can be enabled or disabled as system controller, either instrument can initially be system controller. If the other instrument can only be enabled as system controller, the other instrument will initially have to be the system controller and Special Function 48.1 (Noise Figure Meter is not the system controller on the System Interface Bus.) will have to be active.

System Interface Bus Control (cont'd)

(Special Functions 45 through 49 and 96)

Example (cont'd)

NOTE

Error forty-eight (E48) is generated if the Noise Figure Meter detects another controller on the System Interface Bus and the Noise Figure Meter has been told it would be the controller.

d. Special Function 48.0 will enable the Noise Figure Meter as system controller. Special Function 48.1 will disable the Noise Figure Meter as system controller. Use the appropriate commands to enable or disable the other controller.

NOTE

The Noise Figure Meter is set up to be the system controller when shipped from the factory, after memory (RAM) loss or when Special Function 0.9 is used.

e. Connect the Noise Figure Meter, external computer and the second instrument controller to the Hewlett-Packard Interface Bus (HP-IB).

f. Connect the Noise Figure Meter, second instrument controller, the local oscillator, plotter and any other instruments to be controlled to the System Interface Bus (SIB).

Computer Control. The following discussion will describe how the computer will pass control between the Noise Figure Meter and the other controller.

If the Noise Figure Meter has control of the System Interface Bus and the other controller needs to have control, the computer will send 49.2SP or the HP-IB code CR. This will convey to the Noise Figure Meter to release control of the System Interface Bus. The other controller will be told to take control, using the appropriate code for that instrument.

The other controller will now have control of the System Interface Bus and the Noise Figure Meter will display the message "Ctrl OFF."

When the Noise Figure Meter needs to be controller, the computer must tell the other controller to release control, using the appropriate code for that instrument. The Noise Figure Meter is then told to take control, using 49.3SP or the HP-IB code CT. Once the Noise Figure Meter is the controller, it will no longer display the message "Ctrl OFF."

For HP-IB codes, refer to the Procedure above.

Program Codes

HP-IB

Indications

As a special function code is entered it appears in the left display. The code remains there until the SPECIAL FUNCTION key is pressed.

When the Noise Figure Meter is not the System Interface Bus controller, "Ctrl" appears in the INSERTION GAIN display and "OFF" appears in the NOISE FIGURE display.

When the Noise Figure Meter is in Pass Through Mode, "PASS" appears in the INSERTION GAIN display and "thru" appears in the NOISE FIGURE display.

When the Noise Figure Meter is doing a plot, "Plot" appears in the INSERTION GAIN display.

System Interface Bus Control (cont'd)

(Special Functions 45 through 49 and 96)

Comments

The following program example shows how an external controller would request that the Noise Figure Meter perform a serial poll of a device on the System Interface Bus (SIB):

NOTE

The following example assumes that the address of the Noise Figure Meter is 708 and the address of the device on the SIB, to be polled, is 19.

This program was written in BASIC language 3.0 using the HP 9000 Series 200 Model 236 computer.

```

10 Spoll:                                !Serial poll of device on the Noise Figure
                                        !Meter System Interface Bus.
20 Addr=19                                !Address of device on SIB to be polled.
30 OUTPUT 708;"SB";Addr;"EN"             !Tell Noise Figure Meter
                                        !to poll device on SIB.
40 OUTPUT 708;"H1"                        !Output frequency, insertion
                                        !gain and noise figure windows.
50 OUTPUT 708;"SB"                        !Show serial poll return value.
60 Error=0                                !Clear subroutine error code.
70 Wait_poll:                              !Wait for the serial poll to finish.
80 ENTER 708;V,W2,W3                      !Get Noise Figure Meter frequency window.
90 !The value returned will be 2000 plus 19 until the
100 !poll is completed or it is aborted due to an error,
110 !such as, the device is not present or is off.
120 !
130 IF V≥2000 THEN GOTO Wait_poll          !Wait for the serial poll to be complete.
140 !
150 !At this point, the poll is complete or is in error.
160 !We find out which is the case in the next statement.
170 !If the value is 1000 plus 19, there has been an error,
180 !the device was not found or it was off. If the device
190 !was present and the serial poll worked, the value will
200 !be 0 through 255, for the serial poll value.
210 !
220 IF V≥1000 THEN                        !An error has occurred
230 Error=1                                !Indicate error to program
240 END IF
250 !
260 !The subroutine will return V=serial poll value
270 !and Error=0, if the serial poll is valid, or Error <> 0,
280 !if the serial poll failed.
290 !
300 IF Error <> 0 THEN
310 PRINT "SERIAL POLL FAILED"
320 ELSE
330 PRINT "SERIAL POLL VALUE = ";V
340 END IF
350 END

```

Related Sections

Measurement Modes 1.0 through 1.9

Temperature Units Selection (Special Function 11)

Description

Temperature units are used when loss temperature, T_{hot} , or T_{cold} data is entered into the instrument. The instrument can accept temperature data entries in three different measurement units: Kelvins (K), Fahrenheit ($^{\circ}F$), or Celsius ($^{\circ}C$).

Procedure

To select a temperature unit, key in the corresponding Special Function code and then press the SPECIAL FUNCTION key.

Special Function		Program Code HP-IB	Lights Special ¹ Function Key	Stored in Continuous Memory	Can be Stored and Recalled	Special Function 0.0 Conditions	Preset (and HP-IB Clear) Conditions	Special Function 0.9 Conditions
Description	Code							
K	11.0	D0 or 11.0SP	N	Y	Y	On	On	On
$^{\circ}C$	11.1	D1 or 11.1SP	N	Y	Y	Off	Off	Off
$^{\circ}F$	11.2	D2 or 11.2SP	N	Y	Y	Off	Off	Off

¹Table categories are explained in the Special Functions Detailed Operating Instruction.

It is not necessary to select temperature units each time temperature data is entered. Once a temperature unit has been selected, all temperature data are entered and displayed in the same unit until that unit is changed (either by Special Function 0.9, PRESET, Special Function 0.0, or by another temperature unit selection).

After a temperature unit has been selected, one of the special functions listed below must be active before temperature data can be entered.

Description	Special Function Code	Range of Values		
		K	$^{\circ}C$	$^{\circ}F$
Enter and Use T_{hot}	5.4	0 to 14824	-273.2 to 14551	-459.7 to 26224
Enter T_{cold}	6.0	0 to 9999	-273.2 to 9725.9	-459.7 to 17539
Enter Temperature of Losses	34.3	0 to 9999	-273.2 to 9725.9	-459.7 to 17539

Next, key in a value for temperature (within the specified range) and press the ENTER key. Up to five digits are allowed for temperature entries. If a minus sign is used, only four digits are allowed. The maximum resolution is to three places to the right of the decimal point.

Temperature Units Selection (cont'd)

(Special Function 11)

Example To enter a value of 75 °F for T_{cold} :

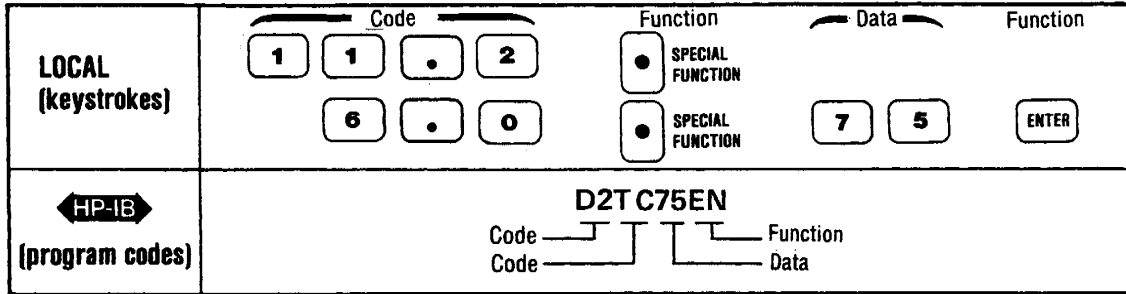

Program Codes For HP-IB codes, refer to Procedure above.



Indications When temperature data has been entered correctly, the selected unit appears in the left display.

Comments The equations used to convert from one temperature unit to another are:
 $K = °C + 273.15$
 $°F = (9/5)°C + 32$

Related Sections
 ENR Table Entry
 Loss Compensation
 Special Functions
 Spot ENR, T_{hot} , T_{cold} and ENR Table Selection

Trigger Selection (Special Function 30)

Description

Special Function 30.0 selects free run triggering for continuous measurements.

Special Function 30.1 selects trigger hold to prevent continuous measurements. When trigger hold is active, the frequency and results of the last measurement are held and displayed. No additional measurements are made and the displayed data can be read over the HP-IB as many times as required. Trigger hold is useful when the measurement setup must be reconfigured before making the next measurement.

Special Function 30.2 triggers one measurement and then returns to the previously selected trigger mode. Normally, this trigger execute command is used in conjunction with the trigger hold mode. Once the measurement is complete, the results are displayed and are available via the HP-IB. The measurement results are also output to an oscilloscope or recorder if one is connected to the rear panel X, Y and Z connectors. If a smoothing factor other than one has been selected, the Noise Figure Meter makes the number of measurements required by the selected smoothing factor before the smoothed measurement is displayed or available via the HP-IB.

Procedure

To select a specific triggering mode, key in the corresponding Special Function code and then press the SPECIAL FUNCTION key.

Special Function		Program Code HP-IB	Lights Special ¹ Function Key	Stored in Con- tinuous Memory	Can be Stored and Recalled	Special Function 0.0 Conditions	Preset (and HP-IB Clear) Conditions	Special Function 0.9 Conditions
Description	Code							
Free Run	30.0	T0 or 30.0SP	N	N	N	On	On	On
Hold	30.1	T1 or 30.1 SP	N	N	N	Off	Off	Off
Execute	30.2	T2 or 30.2SP	N	N	N	Off	Off	Off

¹Table categories are explained in the Special Functions Detailed Operating Instruction.

Example

To select trigger hold and then execute a single measurement and return to trigger hold:

LOCAL (keystrokes)	<div style="display: flex; justify-content: center; align-items: center; gap: 10px;"> <div style="text-align: center;">Code</div> <div style="display: flex; gap: 5px;"> <div style="border: 1px solid black; border-radius: 5px; padding: 2px 10px;">3</div> <div style="border: 1px solid black; border-radius: 5px; padding: 2px 10px;">0</div> <div style="border: 1px solid black; border-radius: 5px; padding: 2px 10px;">.</div> <div style="border: 1px solid black; border-radius: 5px; padding: 2px 10px;">1</div> </div> </div> <div style="display: flex; justify-content: center; align-items: center; gap: 10px; margin-top: 10px;"> <div style="border: 1px solid black; border-radius: 5px; padding: 2px 10px;">3</div> <div style="border: 1px solid black; border-radius: 5px; padding: 2px 10px;">0</div> <div style="border: 1px solid black; border-radius: 5px; padding: 2px 10px;">.</div> <div style="border: 1px solid black; border-radius: 5px; padding: 2px 10px;">2</div> </div>	<div style="text-align: center; margin-bottom: 10px;">Function</div> <div style="display: flex; flex-direction: column; gap: 10px;"> <div style="display: flex; align-items: center;"> <div style="border: 1px solid black; border-radius: 50%; width: 20px; height: 20px; margin-right: 5px;"></div> <div style="font-size: 8px;">SPECIAL FUNCTION</div> </div> <div style="display: flex; align-items: center;"> <div style="border: 1px solid black; border-radius: 50%; width: 20px; height: 20px; margin-right: 5px;"></div> <div style="font-size: 8px;">SPECIAL FUNCTION</div> </div> </div>
HP-IB (program codes)	T1T2	

Trigger Selection (cont'd) (Special Function 30)

**Program
Codes****HP-IB**

For HP-IB codes, refer to Procedure.

Indications

When Special Function 30.0 is active, the front panel displays update continuously. When Special Function 30.1 is active, the front panel displays do not change. When Special Function 30.2 is active, the Noise Figure Meter makes one measurement and then returns to the last selected trigger mode.

Comments

When performing a triggered calibration, only the HP-IB mnemonic code T2 can be used. The Noise Figure Meter does not respond to the alternate 30.2SP code.

**Related
Sections**

Calibrate
Measurement Modes 1.0 through 1.9
Smoothing
Special Functions

SECTION IV PERFORMANCE TESTS

4-1. INTRODUCTION

The procedures in this section test the HP 8970B's electrical performance using the specifications of Table 1-1 as the performance standards. All tests can be performed without access to the interior of the instrument.

These tests, in conjunction with the performance tests of the HP 8971B/C Noise Figure Test Set, System Local Oscillator and Noise Source, verify the performance of the Noise Figure Measurement System.

NOTES

Unless otherwise noted, no warm-up period is required for the tests.

Line voltage must be within +5% and -10% of nominal, if the performance tests are to be considered valid.

4-2. EQUIPMENT REQUIRED

Equipment required for the performance tests is listed in Table 1-11, Recommended Test Equipment in Section I.

in Section I. Any equipment that satisfies the critical specifications given in the table may be substituted for the recommended model(s).

4-3. TEST RECORD

Results of the performance tests may be tabulated on the Test Record at the end of the procedures. The Test Record lists all of the tested specifications and their acceptable limits. The results, recorded at incoming inspection, can be used for comparison in periodic maintenance and troubleshooting and after repairs or adjustments.

System performance is guaranteed if each instrument in the system is calibrated.

4-4. CALIBRATION CYCLE

This instrument requires periodic verification of performance. Depending on the use and environmental conditions, the instrument should be checked using the following performance tests at least once every year.

The instruments that are part of the Noise Figure Measurement System should be calibrated once a year.

PERFORMANCE TESTS

4-5. TUNING ACCURACY PERFORMANCE TEST

Specification TUNING ACCURACY: (from 10° to 40°C) $\pm(1 \text{ MHz} + 1\% \text{ of frequency})$, $\pm 6 \text{ MHz}$ maximum.

Description The Noise Figure Meter is tuned to the frequency where accuracy is to be tested. The point of maximum IF signal level is found by stepping the signal source through the passband while monitoring the level at the internal noise power detector. A power reference is set, and the 3-dB passband frequencies are determined. The tuned center frequency of the Noise Figure Meter is then found as the average of the 3-dB frequencies. This tuned frequency is compared to limits derived from the specifications above.

Equipment: Signal Generator HP 8340B

- Procedure**
1. Connect the signal generator RF output to the Noise Figure Meter INPUT.
 2. Turn on the equipment and allow it to warm up for one half hour. Set the signal generator output level to -30 dBm .
 3. On the Noise Figure Meter, key in 31.2 SPECIAL FUNCTION to execute a frequency calibration, then key in 31.1 SPECIAL FUNCTION to inhibit any further frequency calibrations. Key in 10.2 SPECIAL FUNCTION to set the display units to read Y-Factor in dB.
 4. Tune both the Noise Figure Meter and the signal generator to 10 MHz (20 MHz, opt 020).
 5. On the Noise Figure Meter, key in 80.0 SPECIAL FUNCTION to display the noise power detector output in volts. Key in 62.0 SPECIAL FUNCTION to hold the RF attenuators. Key in 72.0 SPECIAL FUNCTION to hold the IF attenuators.
 6. Tune the signal generator up and down in 100 kHz steps until the maximum voltage display on the Noise Figure Meter is located. The 3-dB point should be within approximately 4 MHz of center frequency.
 7. On the Noise Figure Meter, key in 14.1 SPECIAL FUNCTION to activate the manual measurement mode and make a cold measurement. Key in 14.2 SPECIAL FUNCTION to exit the cold measurement mode (and store that value) and to make hot measurements. Finally, key in 15.1 SPECIAL FUNCTION to set the Noise Figure Meter to actively display the ratio of hot to cold values. The NOISE FIGURE display should now indicate 0.00 dB.
 8. Tune the signal generator up and down to find the 3-dB frequencies to within 100 kHz. Find the center frequency by summing the 3-dB frequencies and dividing by two. The center frequency should be within the limits in the table in step 9.

PERFORMANCE TESTS

INPUT SWR PERFORMANCE TEST (cont'd)

- Connect the test port of the SWR bridge to the Noise Figure Meter INPUT. Slowly tune the Signal Generator in 10 MHz steps down in frequency to 10 MHz. While tuning, note each frequency at which the power meter peaks at less than the value given in the following table, below the 0 dB reference set in step 4. For example, if the power meter display showed -11.0 dB at a frequency between 10 MHz and 1600 MHz for a standard product, then the frequency should be noted. However, a reading of -13 dB indicates a return loss well within specification.

NOISE FIGURE METER	FREQUENCY RANGE	POWER METER PEAK
Standard Product	10 MHz to 1600 MHz	< 12.5 dB
Option 020, serial prefix 3811 and above	10 MHz to 1600 MHz 1600 MHz to 2047 MHz	<11.5 dB <10.4 dB
Option 020, serial prefixes below 3811	10 MHz to 1600 MHz 1600 MHz to 2047 MHz	<12.5 dB <10.4 dB

- For each frequency noted in step 5, tune the Signal Generator and the Noise Figure Meter to that frequency. Disconnect the SWR bridge from the Noise Figure Meter INPUT, and set a power meter reference. Reconnect the SWR bridge to the Noise Figure Meter INPUT and check the power meter reading against the following table.

INPUT SWR PERFORMANCE TEST	Min.	Actual	Max
+20 dB Input Gain Setting Frequency _____ MHz		_____	-11.73 dB* (10.88 dB, opt 020) < 1600 MHz
_____ MHz		_____	-9.63 dB < 2047 MHz (opt 020)
+10 dB Input Gain Setting Frequency _____ MHz		_____	-11.73 dB* (10.88 dB, opt 020) < 1600 MHz
_____ MHz		_____	-9.63 dB < 2047 MHz (opt 020)
0 dB Input Gain Setting Frequency _____ MHz		_____	-11.73 dB* (10.88 dB, opt 020) < 1600 MHz
_____ MHz		_____	-9.63 dB < 2047 MHz (opt 020)

* -11.73 dB applies to option 020 below serial prefix 3811.

- On the Noise Figure Meter, key in 60.2 SPECIAL FUNCTION to set the input gain to +10 dB. Repeat steps 4 through 6.
- Key in 60.3 SPECIAL FUNCTION to set the input gain to 0dB and repeat steps 4 through 6.

PERFORMANCE TESTS

4-7. NOISE FIGURE RANGE AND ACCURACY PERFORMANCE TEST

Specification NOISE FIGURE MEASUREMENT CHARACTERISTICS Range: 0.0 to 30 dB. Instrumentation Uncertainty: ± 0.1 dB for a noise source in a 0 to 55°C in a 300K environment with a noise source ENR of 14 to 16 dB.

Description Level ratios of -0.1 dB, -1 dB, -5 dB, -10 dB, -15 dB, and -20 dB are generated. The levels are measured on the power meter, and linear power ratios are computed. The levels are simultaneously measured on the Noise Figure Meter, and linear voltage ratios are computed. The voltage ratios are squared and then subtracted from the linear power ratios to compute the Y-Factor error. This error is compared to accuracy limits derived from the 0.1 dB noise figure accuracy specification. (A 15 dB ENR value is assumed.) The reading at -20 dB and the reading at -5 dB are used to compute a second 15 dB ratio. This ratio is also checked for accuracy.

NOTES

This test is difficult to perform. Passing the test requires minimum drift in both the measurement equipment and the Noise Figure Meter. The more rapidly the test is performed, the more closely the test results will indicate the actual performance of the instrument. If the instrument fails by a narrow margin, performing the test more quickly will probably allow the instrument to pass.

Since the Noise Figure Meter is highly sensitive to RF signals at its input, spurious transmissions or noise can adversely affect performance test results. Use short well shielded cables and a minimum of adapters when performing this test. A screen room might be required.

Equipment

Attenuator, 6 dB	HP 8491A Opt. 006
Attenuator, 1 dB Step.	HP 8494A Opt. 001
Calculator	HP 41CV
Digital Voltmeter	HP 3456A
Filter, Low-Pass	HP 360B or RLC F-10-1500
Power Meter	HP 436A
Power Sensor	HP 8484A/HP 8481D
Power Splitter	HP 11667A
Signal Generator	HP 8340B

Procedure

1. Connect equipment as shown in Figure 4-2, except do not connect the power sensor to the step attenuator.
2. Turn on all equipment and allow it to warm up for one hour.
3. Set the signal generator for a 50 MHz continuous wave output at -17 dBm.
4. On the Noise Figure Meter, set FREQUENCY to 50 MHz. Key in 80.0 SPECIAL FUNCTION to display the noise power detector output in volts (voltmeter mode). Key in 31.1 SPECIAL FUNCTION to inhibit frequency calibrations. Key in 60.5 SPECIAL FUNCTION to set the input gain to -20 dB. Key in 70.6 SPECIAL FUNCTION to set the IF attenuation to -25 dB. Set the smoothing factor to 4 using the INCREASE and DECREASE keys.
5. Zero the power meter and set the 1 dB step attenuator to 10 dB. Connect the power sensor to the 1 dB step attenuator as shown in Figure 4-2.

PERFORMANCE TESTS

NOISE FIGURE RANGE AND ACCURACY PERFORMANCE TEST (cont'd)

Procedure (cont'd)

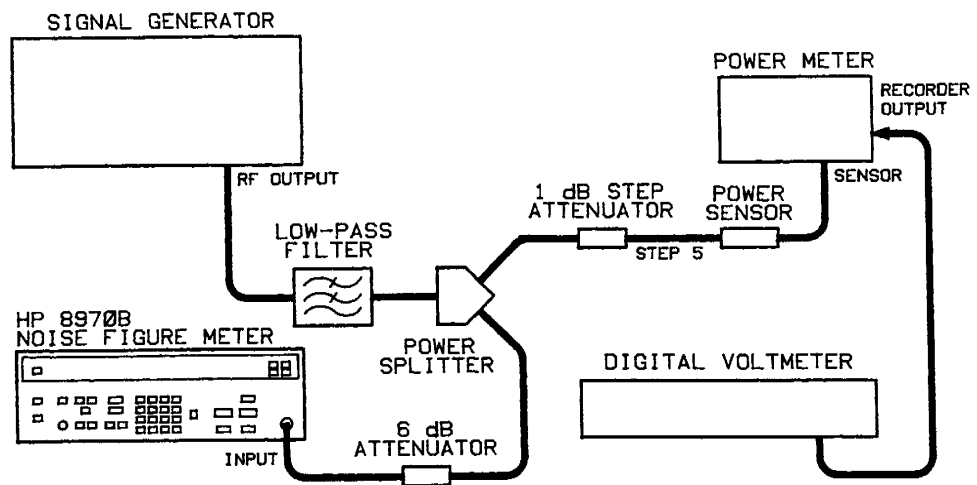

Figure 4-2. Noise Figure Instrumentation Accuracy Test Setup

6. Peak the Noise Figure Meter display reading by tuning the signal generator up and down in frequency in 10 kHz increments.
7. Increase the signal generator power in 0.1 dB steps until the combined INSERTION GAIN and NOISE FIGURE displays on the Noise Figure Meter indicate as close as possible to 1.00000 volts. The signal generator power should be near -14.7 dBm. Note this power level as indicated on the signal generator.
 _____ dBm
8. Set the step attenuator for a power meter reading as close as possible to 1.000 μ W.
9. Set the digital voltmeter to read dc volts on the high resolution setting. Using the manual trigger control, trigger several readings then stop on a typical reading. Note this reading using full resolution.
 _____ Vdc
10. Note the voltmeter mode reading on the Noise Figure Meter also using full resolution.
 _____ Vdc
11. Decrease the signal generator power by 0.1 dB.
12. Using the same technique as in step 9, take a voltmeter reading.
 _____ Vdc
13. Note the new voltmeter mode reading on the Noise Figure Meter.
 _____ Vdc
14. Decrease the signal generator output power to 1 dB below that set in step 7.

PERFORMANCE TESTS

NOISE FIGURE RANGE AND ACCURACY PERFORMANCE TEST (cont'd)

- Procedure (cont'd)**
15. Using the same technique as in step 9, take a voltmeter reading. _____ Vdc
 16. Note the new voltmeter mode reading on the Noise Figure Meter. _____ Vdc
 17. Decrease the signal generator output power to 5 dB below that set in step 7.
 18. Using the same technique as in step 9, take a voltmeter reading. _____ Vdc
 19. Note the new voltmeter mode reading on the Noise Figure Meter. _____ Vdc
 20. Decrease the signal generator output power to 10 dB below that set in step 7.
 21. Using the same technique as in step 9, take a voltmeter reading. (Note that the power meter may change ranges for this reading. If it does, the voltmeter reading taken must be decreased by a factor of 10.) _____ Vdc
 22. Note the new voltmeter mode reading on the Noise Figure Meter. _____ Vdc
 23. Decrease the signal generator output power to 15 dB below that set in step 7.
 24. Using the same technique as in step 9, take a voltmeter reading. (Remember to decrease this reading by a factor of 10.) _____ Vdc
 25. Note the new voltmeter mode reading on the Noise Figure Meter. _____ Vdc
 26. Decrease the signal generator output power to 20 dB below that set in step 7.
 27. Using the same technique as in step 9, take a voltmeter reading. (Note that the power meter may change ranges again. If so this voltmeter reading must be decreased by a factor of 100.) _____ Vdc
 28. Note the new voltmeter mode reading on the Noise Figure Meter. _____ Vdc
-

PERFORMANCE TESTS

NOISE FIGURE RANGE AND ACCURACY PERFORMANCE TEST (cont'd)

Procedure (cont'd)

29. Fill in the table below using the readings from the appropriate steps above. For the column on the far right, square the readings in the previous column.

Voltmeter Readings (Vdc)		Noise Figure Meter Readings		
			Vdc	(Vdc) ²
Step 9	_____	Step 10	_____	_____
Step 12	_____	Step 13	_____	_____
Step 15	_____	Step 16	_____	_____
Step 18	_____	Step 19	_____	_____
Step 21	_____	Step 22	_____	_____
Step 24	_____	Step 25	_____	_____
Step 27	_____	Step 28	_____	_____

30. Fill in the table below by computing the indicated ratios (Y-Factors). The ratios of the second set of columns should be computed from the squared voltages from the previous table. Subtract the ratios of the second set of columns from those of the first set to yield the net error (difference). The result should be within the indicated limits.

Ratios (Y-Factors)				Difference		
				Min.	Actual	Max.
(Step 9)		(Step 10) ²				
_____	_____	_____	_____	-0.00053	_____	+0.00054
(Step 12)		(Step 13) ²				
_____	_____	_____	_____	-0.00589	_____	+0.00603
(Step 9)		(Step 10) ²				
_____	_____	_____	_____	-0.04922	_____	+0.05037
(Step 15)		(Step 16) ²				
_____	_____	_____	_____	-0.20487	_____	+0.20964
(Step 18)		(Step 19) ²				
_____	_____	_____	_____	-0.69706	_____	+0.71330
(Step 21)		(Step 22) ²				
_____	_____	_____	_____	-0.69706	_____	+0.71330
(Step 24)		(Step 25) ²				
_____	_____	_____	_____			
(Step 27)		(Step 28) ²				
_____	_____	_____	_____			

PERFORMANCE TESTS

4-8. GAIN MEASUREMENT UNCERTAINTY PERFORMANCE TEST

Specification **GAIN MEASUREMENT CHARACTERISTICS** Range: -20 to $> +40$ dB. Instrumentation Uncertainty: ± 0.15 dB.

Description The Noise Figure Meter uses internal IF attenuator values for measuring gain. Prior to performing the Gain Measurement Uncertainty Performance Test, the IF attenuators are calibrated to ensure valid gain measurements.

For the IF attenuator calibration the IF attenuators are measured by taking a reference power reading, switching in an attenuator and then taking another power measurement. The relative power change is equal to the IF attenuator value. The power change is calculated using a voltmeter to measure the change in voltage from the Recorder Output of the power meter.

The attenuator values are computed as the ratio of measured voltages (linear units) rather than in decibels (logarithmic units). The linear value of the 15 dB attenuator is calculated by multiplying the linear value for the 10 dB attenuator and the linear value for the 5 dB power change observed when the attenuators change from 10 to 15 dB. The 25 dB attenuator is calculated in the same way, using the 20 dB instead of the 10 dB attenuator value. The calibrated IF attenuator values are recorded in Table 4-1 and entered into the Noise Figure Meter.

For the Gain Measurement Uncertainty Performance Test, net gain is generated by removing attenuation from a high gain setup. The net gain is alternately measured first by a power meter and then by the Noise Figure Meter. The two measurements should compare to within 0.15 dB.

NOTES

This test is difficult to perform. Passing the test requires minimum drift in both the measurement equipment and the Noise Figure Meter. The more rapidly the test is performed, the more closely the test results will indicate the actual performance of the instrument. If the instrument fails by a narrow margin, performing the test more quickly will probably allow the instrument to pass.

Since the Noise Figure Meter is highly sensitive to RF signals at its input, spurious transmissions or noise can adversely affect performance test results. Use short well shielded cables and a minimum of adapters when performing this test.

Equipment	Attenuator, 10 dB (2 required)	HP 8491A Opt. 010
	Attenuator, 20 dB	HP 8491A Opt. 020
	Attenuator, 1 dB Step	HP 8494A Opt. 001
	Attenuator, 10 dB Step	HP 8495A Opt. 001
	Filter, Low-Pass.	HP 360B or RLC F-10-1500
	Noise Source	HP 346B Opt. 001
	Power Meter	HP 436A
	Power Sensor	HP 8484A/HP 8481D
	Power Splitter	HP 11667A
	Wideband Amplifier I	HP 8447D Opt. 010
	Wideband Amplifier II	HP 8447F Opt. 010
	Digital Voltmeter	HP 3456A

PERFORMANCE TESTS

GAIN MEASUREMENT UNCERTAINTY PERFORMANCE TEST (cont'd)**Procedure IF Attenuator Calibration**

1. Connect the noise source to the Noise Figure Meter's NOISE SOURCE DRIVE OUTPUT.
2. Turn on all equipment and allow it to warm up for a half hour.
3. Zero and calibrate the power meter and sensor.
4. Set the 10 dB step attenuator to 70 dB and connect the equipment as shown in Figure 4-3.

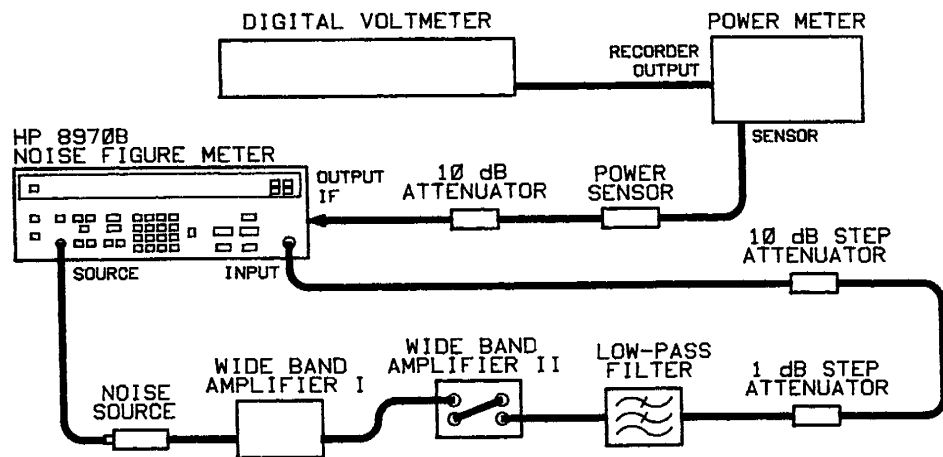

Figure 4-3. IF Attenuator Calibration Setup

5. On the Noise Figure Meter press
 - 70.1 SPECIAL FUNCTION to set the IF attenuators to 0 dB
 - 60.1 SPECIAL FUNCTION to set the RF attenuators to +20 dB.
6. Put the power meter in range 3. Do not allow the power meter to autorange. (For the HP 436A Power Meter, adjust the 10 dB and the 1 dB step attenuators until the power meter reads -45 dBm. Press RANGE HOLD to set the power meter to RANGE 3.)
7. Adjust the step attenuators for a voltmeter reading as close to 1 volt as possible. On the voltmeter, select single triggering. If the voltmeter has filtering, turn it on. Take 10 voltmeter readings. Using at least four digits to the right of the decimal point, calculate the average of the readings.

(On the HP 3456A Digital Voltmeter, press FILTER on to enable the analog filter, 10 STORE 6 to store 10 readings per trigger, SINGLE to select the single trigger mode, MATH 2 to turn on the statistical math mode and SINGLE to trigger 10 voltmeter readings. When the voltmeter has finished taking the 10 readings, press RECALL 0 to recall the average of the readings.)

PERFORMANCE TESTS

GAIN MEASUREMENT UNCERTAINTY PERFORMANCE TEST (cont'd)**Procedure
(cont'd)**

Record the average of the voltmeter readings. This is the reference voltage for the 5 dB and 10 dB attenuator calculations.

_____ Vref1

NOTE

When using the HP 3456A Digital Voltmeter's statistical math mode to calculate an average, be sure to clear the math register before triggering the set of readings to be averaged. Press MATH 0 to clear the register and then MATH 2 to enable math mode.

8. On the Noise Figure Meter press 70.2 SPECIAL FUNCTION to switch in the internal 5 dB attenuator. Take 10 voltmeter readings. Using at least four digits to the right of the decimal point, calculate the average of the voltmeter readings.

(On the HP 3456A Digital Voltmeter, press MATH 0 to clear the math registers by turning math mode off, MATH 2 to enable the statistical math mode and SINGLE to trigger 10 voltmeter readings. When the voltmeter has finished taking the 10 readings, press RECALL 0 to recall the average of the readings.)

Record the average of the voltmeter readings.

_____ Vavg (5 dB)

NOTE

The limits for each attenuator are shown in linear units, that is, as the ratio of measured voltages. If an attenuator is outside its limits, it may be defective. Refer to Section VIII in the Service Manual for troubleshooting information.

9. Compute the 5 dB attenuator value as shown:

$$V_{\text{ref1}}/V_{\text{avg}} (5 \text{ dB}) = \text{_____} (>2.661; <3.758 \text{ for } 5 \text{ dB attenuator})$$

(For example, $V_{\text{ref1}} = 0.986622$ volts and $V_{\text{avg}} (5 \text{ dB}) = 0.312579$ volts. $0.986622 \text{ volts} / 0.312579 \text{ volts} = 3.15639$. This value is within the stated limits.)

10. On the Noise Figure Meter press 70.3 SPECIAL FUNCTION to switch in the internal 10 dB attenuator. Take 10 voltmeter readings. Using at least four digits to the right of the decimal point, calculate and record the average of the readings.

_____ Vavg (10 dB)

11. Compute the 10 dB attenuator value as shown:

$$V_{\text{ref1}}/V_{\text{avg}} (10 \text{ dB}) = \text{_____} (>8.414; <11.885 \text{ for } 10 \text{ dB attenuator})$$

12. On the voltmeter, select internal triggering. If the voltmeter has filtering, turn it off. Reduce the 10 dB step attenuator by 10 dB, and adjust the 1 dB step attenuator until the voltmeter reads as close to 1 volt as possible. Select single triggering on the voltmeter. If the voltmeter has filtering, turn it on. Take 10 voltmeter readings.
-

PERFORMANCE TESTS

GAIN MEASUREMENT UNCERTAINTY PERFORMANCE TEST (cont'd)**Procedure
(cont'd)**

Using at least four digits to the right of the decimal point, calculate and record the average of the readings. This is the reference voltage for the 15 dB and 20 dB attenuator calculations.

_____ Vref2

13. On the Noise Figure Meter press 70.4 SPECIAL FUNCTION to switch in the internal 15 dB attenuator. Take 10 voltmeter readings. Then, calculate and record the average of those readings.

_____ Vavg (15 dB)

14. Compute the 15 dB attenuator value as shown:

(Result from step 11) * Vref2/Vavg (15 dB) = _____ (>26.607; <37.584 for 15 dB attenuator)

15. On the Noise Figure Meter press 70.5 SPECIAL FUNCTION to switch in the internal 20 dB attenuator. Take 10 voltmeter readings. Then, calculate and record the average of the readings.

_____ Vavg (20 dB)

16. Compute the 20 dB attenuator value as shown:

(Result from step 11) * Vref2/Vavg (20 dB) = _____ (>84.140; <118.850 for 20 dB attenuator)

17. On the voltmeter, select internal triggering. If the voltmeter has filtering, turn it off. Reduce the 10 dB step attenuator by 10 dB and adjust the 1 dB step attenuator until the voltmeter reads as close to 1 volt as possible. On the voltmeter, select single triggering. If the voltmeter has filtering, turn it on. Take 10 voltmeter readings. Using at least four digits to the right of the decimal point, calculate and record the average of the readings. This is a reference voltage used in the 25 dB and 30 dB attenuator calculations.

_____ Vref3

18. On the Noise Figure Meter press 70.6 SPECIAL FUNCTION to switch in the internal 25 dB attenuator. Take 10 voltmeter readings. Then, calculate and record the average of the readings.

_____ Vavg (25 dB)

19. Compute the 25 dB attenuator value as shown:

(Result from step 16) * Vref3/Vavg (25 dB) = _____ (>266.07; <375.84 for 25 dB attenuator)

20. On the Noise Figure Meter press 70.7 SPECIAL FUNCTION to switch in the internal 30 dB attenuator. Take 10 voltmeter readings. Then, calculate and record the average of the readings.

_____ Vavg (30 dB)

21. Compute the 30 dB attenuator value as shown:

(Result from step 16) * Vref3/Vavg (30 dB) = _____ (>841.4; <1188.5 for 30 dB attenuator)

PERFORMANCE TESTS

GAIN MEASUREMENT UNCERTAINTY PERFORMANCE TEST (cont'd)

Procedure (cont'd)

- 22. On the voltmeter, select internal triggering. If the voltmeter has filtering, turn it off. Reduce the 10 dB step attenuator by 10 dB and adjust the 1 dB step attenuator until the voltmeter reads as close to 1 volt as possible. On the voltmeter, select single triggering. If the voltmeter has filtering, turn it on. Take 10 voltmeter readings. Using at least four digits to the right of the decimal point, calculate and record the average of the readings. This is the reference voltage for the 35 dB attenuator calculation. _____ Vref4

- 23. On the Noise Figure Meter press 70.8 SPECIAL FUNCTION to switch in the internal 35 dB attenuator. Take 10 voltmeter readings, and then calculate the average of those readings. Record the average. _____ Vavg (35 dB)

- 24. Compute the 35 dB attenuator value as shown:
 (Result from step 21) * Vref4/Vavg (35 dB) = _____ (>2660.7; <3758.4 for 35 dB attenuator)

- 25. Enter the measured attenuator values in Table 4-1.

Table 4-1. IF Attenuator Values

Date:		
Nominal Value		Measured Value
Log Units	Linear Units	Linear Units
5 dB	3.162	_____
10 dB	10.000	_____
15 dB	31.623	_____
20 dB	100.000	_____
25 dB	316.23	_____
30 dB	1000.0	_____
35 dB	3162.3	_____

Entering IF Attenuator Values

- 26. Enter the measured attenuator values recorded in Table 4-1 into the Noise Figure Meter:

NOTE

It is not necessary to perform steps 26a through h if you only want to read the IF attenuator values and record them in Table 4-1.

PERFORMANCE TESTS

GAIN MEASUREMENT UNCERTAINTY PERFORMANCE TEST (cont'd)**Procedure
(cont'd)**

- a. Key in 93.1 SPECIAL FUNCTION. (This enables you to enter a RAM address.)
 - b. Key in 65452 and then press ENTER. (This is the RAM location where you will find the address of the memory protection word. The memory protection word must be modified before you can change the IF attenuator values stored in RAM.)
 - c. Key in 93.3 SPECIAL FUNCTION. (This displays the address of the memory protection word.)
 - d. Record the address of the memory protection word, which is shown in the left display of the Noise Figure Meter.
 - e. Key in 93.1 SPECIAL FUNCTION.
 - f. Key in the memory protection word address recorded in step d and then press ENTER.
 - g. Key in 93.3 SPECIAL FUNCTION.
 - h. Key in 20299 and then press ENTER. (The value 20299 disables the memory protection and allows you to change the IF attenuator values. Turning the instrument off and then on turns memory protection back on.)
 - i. Key in 93.1 SPECIAL FUNCTION.
 - j. Key in 65460 and then press ENTER. (This is the RAM location where you will find the start address of the IF attenuator calibration table.)
 - k. Key in 93.3 SPECIAL FUNCTION. (This displays the start address of the IF attenuator calibration table.)
 - l. Add 1 to the least significant digit shown in the left display of the Noise Figure Meter and record the value. 2993 (Address of the first attenuator data in calibration table.)
 - m. Key in 93.0 SPECIAL FUNCTION. (This enables you to enter the RAM address of the first attenuator data in the calibration table. It also automatically increments the address after pressing ENTER so that you can step through the calibration table.)
 - n. Enter the number from step l and press ENTER.
 - o. Key in 93.4 SPECIAL FUNCTION. (This enables you to read and/or modify the 5 dB attenuator value in RAM.)
 - p. The number shown in the left display is the 5 dB attenuator value (in linear units). Key in the new 5 dB attenuator value and press ENTER. (To leave the value shown in the left display unchanged, press ENTER without keying in a new value.)
-

PERFORMANCE TESTS

GAIN MEASUREMENT UNCERTAINTY PERFORMANCE TEST (cont'd)

Procedure (cont'd)

- q. Press 93.4 SPECIAL FUNCTION to view the next attenuator value. Enter the new value and press ENTER.
- r. Repeat step q for each subsequent attenuator value until all values have been entered.
- s. Press FREQUENCY to return to normal operation.

NOTE

Error code E26 (internal IF attenuators not calibrated) will occur after E80 (continuous memory failure). To clear E26, first enter the IF attenuator values by following the procedure in step 26. Then, perform the following:

1. Key in 93.0 SPECIAL FUNCTION.
2. Subtract 1 from the value recorded in step 26l. Enter this value into the Noise Figure Meter and then press ENTER.
3. Key in 93.2 SPECIAL FUNCTION. Then, key in 128 and press ENTER.
4. Press FREQUENCY to return to normal operation.

Gain Measurement Uncertainty Performance Test

27. On the Noise Figure Meter, press PRESET.

NOTE

This procedure relies critically upon the proper setup of the power meter. If readings yield results that are out of specification, check that the calibration adjustment and zero setting of the power meter are valid. Always disconnect the power sensor from the test setup when zeroing.

28. Connect the equipment as shown in Figure 4-4.

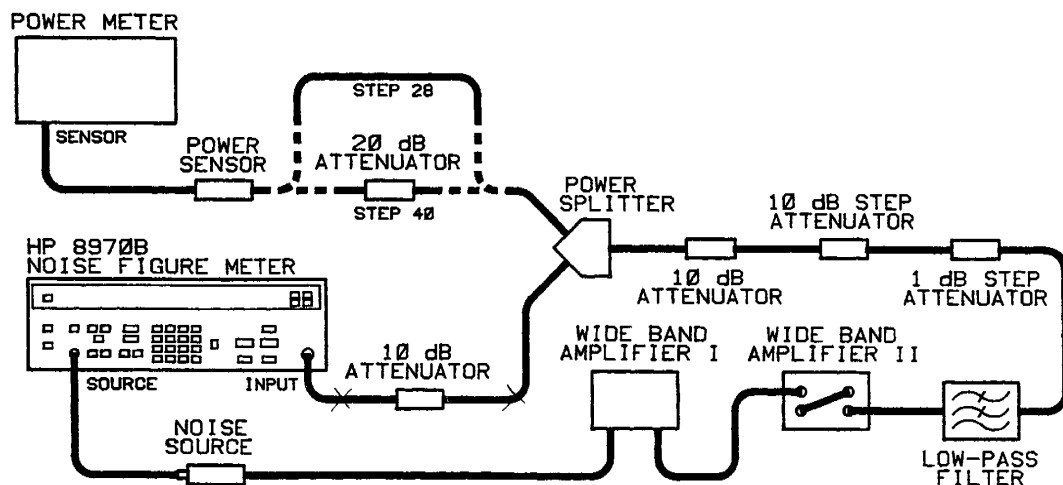

Figure 4-4. Gain Measurement Uncertainty Test Setup

PERFORMANCE TESTS

GAIN MEASUREMENT UNCERTAINTY PERFORMANCE TEST (cont'd)**Procedure
(cont'd)**

29. On the Noise Figure Meter, press the ENR key to access the working ENR table with in the Noise Figure Meter. Using the DATA keys and the ENTER key, modify the 10, 100, 1000 and 2000 MHz ENR entries to correspond to the noise source ENR chart. Exit the ENR table entry mode by pressing the FREQUENCY key.
 30. On the Noise Figure Meter, set START FREQ, STOP FREQ, and FREQUENCY all to 1000 MHz.
 31. Set the 10 dB step attenuator for 40 dB of attenuation. Set the 1 dB step attenuator for a power level no greater than -48 dBm (-53 dBm, opt 020) as read on the power meter.
 32. On the Noise Figure Meter, press INCREASE to set the smoothing factor to 8. Press CALIBRATE twice.
 33. When calibration is complete, key in 81.0 SPECIAL FUNCTION to turn on the noise source and display the noise power detector output in volts (voltmeter mode). Press STORE 1 to store this setting in the instrument memory.
 34. Set a relative reference on the power meter. (Press dBREL key on HP 436).
 35. Set the step attenuator for 30 dB of attenuation. Note the power meter reading.
(Power Meter \approx 10 dB Gain) _____ dB
 36. On the Noise Figure Meter, press NOISE FIGURE AND GAIN. Note the Insertion Gain reading.
(Noise Figure Meter \approx 10 dB Gain) _____ dB
 37. On the Noise Figure Meter, press RECALL 1.
 38. Set the step attenuator for 20 dB of attenuation. Note the power meter reading.
(Power Meter \approx 20 dB Gain) _____ dB
 39. On the Noise Figure Meter, press NOISE FIGURE AND GAIN. Note the Insertion Gain reading.
(Noise Figure Meter \approx 20 dB Gain) _____ dB
 40. Insert a 20 dB attenuator into the setup at the input to the power sensor.
 41. On the Noise Figure Meter, press RECALL 1.
 42. Note the power meter reading. (Power Meter Reference) _____ dB
 43. On the Noise Figure Meter, press NOISE FIGURE AND GAIN. Note the Insertion Gain Reading.
(Noise Figure Meter Reference) _____ dB
 44. On the Noise Figure Meter, press RECALL 1.
-

PERFORMANCE TESTS

GAIN MEASUREMENT UNCERTAINTY PERFORMANCE TEST (cont'd)

**Procedure
(cont'd)**

- 45. Set the step attenuator for 10 dB of attenuation. Note the power meter reading.
(Power Meter \approx 30 dB Gain) _____ dB
- 46. On the Noise Figure Meter, press NOISE FIGURE AND GAIN. Note the Insertion Gain reading.
(Noise Figure Meter \approx 30 dB Gain) _____ dB
- 47. On the Noise Figure Meter, press RECALL 1.
- 48. Set the step attenuator for 0 dB of attenuation. Note the power meter reading.
(Power Meter \approx 40 dB Gain) _____ dB
- 49. On the Noise Figure Meter, press NOISE FIGURE AND GAIN. Note the Insertion Gain reading.
(Noise Figure Meter \approx 40 dB Gain) _____ dB
- 50. Subtract the reading of step 42 from that of step 38. This is the value of the 20 dB attenuator as seen by the power meter.
(20 dB Attenuator) _____ dB
- 51. Subtract the reading of step 43 from that of step 39. This is the Noise Figure Meter reference correction factor.
(Noise Figure Meter Correction Factor) _____ dB
- 52. Fill appropriate values into the following table, then subtract the values for the Noise Figure Meter from the power meter readings above them to yield the net error. The error should be within ± 0.15 dB.

Power Meter	Step 35	Step 38	Step 45 + Step 50	Step 48 + Step 50
	_____ dB	_____ dB	_____ dB	_____ dB
Noise Figure Meter	Step 36	Step 39	Step 46 + Step 51	Step 49 + Step 51
	_____ dB	_____ dB	_____ dB	_____ dB
Error	_____ dB	_____ dB	_____ dB	_____ dB

PERFORMANCE TESTS

4-9. INSTRUMENT NOISE FIGURE PERFORMANCE TEST

Specification INSTRUMENT NOISE FIGURE: <7 dB + 0.003 dB (0.002 dB, opt 020) per MHz on the most sensitive input range.

Description A noise source is connected to the Noise Figure Meter INPUT, and the instrument measures its own noise figure in the UNCORRECTED mode.

Equipment Noise Source HP 346B Opt. 001

- Procedure**
1. Connect the noise source between the SOURCE output and the INPUT of the Noise Figure Meter. Turn on the Noise Figure Meter, then press PRESET. Set FREQ INCR to 100 MHz.
 2. Press the ENR key to access the working ENR table within the Noise Figure Meter. Using the DATA keys and the ENTER key, modify the 10, 1000, 2000, and for opt 020, 3000 MHz ENR entries to correspond to the noise ENR chart. Exit the ENR table entry mode by pressing the FREQUENCY key.
 3. Use the INCREASE key to set the smoothing factor to 4. Select UNCORRECTED NOISE FIGURE.
 4. Note the NOISE FIGURE display reading at each frequency, while using the step up key (up arrow) to tune the Noise Figure Meter through its tuning range. The Noise Figure measurement results should be less than those shown in the table below.

Frequency (MHz)	Noise Figure (dB)	
	Actual	Maximum (Std) (Opt 020)
10	_____	7.03 7.02
110	_____	7.33 7.22
210	_____	7.63 7.42
310	_____	7.93 7.62
410	_____	8.23 7.82
510	_____	8.53 8.02
610	_____	8.83 8.22
710	_____	9.13 8.42
810	_____	9.43 8.62
910	_____	9.73 8.82
1010	_____	10.03 9.02

Frequency (MHz)	Noise Figure (dB)	
	Actual	Maximum (Std) (Opt 020)
1110	_____	10.33 9.22
1210	_____	10.63 9.42
1310	_____	10.93 9.62
1410	_____	11.23 9.82
1510	_____	11.53 10.02
1610	_____	10.22
1710	_____	10.42
1810	_____	10.62
1910	_____	10.82
2010	_____	11.02

Table 4-2. Performance Test Record (1 of 3)

Hewlett-Packard Company Model HP 8970B Noise Figure Meter Serial Number _____		Tested by _____ Date _____		
Para. No.	Test	Results		
		Min.	Actual	Max.
4-5	TUNING ACCURACY PERFORMANCE TEST Tuned Frequency 10 MHz 100 MHz 300 MHz 500 MHz 1000 MHz 1300 MHz 1600 MHz	8.9 MHz 98 MHz 296 MHz 494 MHz 994 MHz 1294 MHz 1594 MHz	_____ _____ _____ _____ _____ _____ _____	11.1 MHz 102 MHz 304 MHz 506 MHz 1006 MHz 1306 MHz 1606 MHz
4-6	INPUT SWR PERFORMANCE TEST +20 dB Input Gain Setting Frequency _____ MHz _____ MHz _____ MHz +10 dB Input Gain Setting Frequency _____ MHz _____ MHz _____ MHz 0 dB Input Gain Setting Frequency _____ MHz _____ MHz _____ MHz		_____ _____ _____ _____ _____ _____ _____	-11.73 dB -11.73 dB -11.73 dB -11.73 dB -11.73 dB -11.73 dB -11.73 dB
4-7	NOISE FIGURE RANGE AND ACCURACY PERFORMANCE TEST Step 9 - Step 10 ² Step 12 - Step 13 ² Step 9 - Step 10 ² Step 15 - Step 16 ² Step 9 - Step 10 ² Step 18 - Step 19 ² Step 9 - Step 10 ² Step 21 - Step 22 ² Step 9 - Step 10 ² Step 24 - Step 25 ² Step 18 - Step 19 ² Step 27 - Step 28 ²	-0.00053 -0.00589 -0.04922 -0.20487 -0.69706 -0.69706	Difference _____ _____ _____ _____ _____ _____	+0.00054 +0.00603 +0.05037 +0.20964 +0.71330 +0.71330

Table 4-2. Performance Test Record (2 of 3)

Para. No.	Test	Results																																															
		Min.	Actual	Max.																																													
4-8	GAIN MEASUREMENT UNCERTAINTY PERFORMANCE TEST																																																
	<table style="width:100%; border:none;"> <tr> <td style="text-align:center;">Power Meter Reading</td> <td style="text-align:center;">Noise Figure Meter Reading</td> <td></td> <td></td> <td></td> </tr> <tr> <td style="text-align:center;">Step 35</td> <td style="text-align:center;">Step 36</td> <td></td> <td></td> <td></td> </tr> <tr> <td style="text-align:center;">_____ dB</td> <td style="text-align:center;">_____ dB</td> <td style="text-align:center;">-0.15 dB</td> <td style="text-align:center;">_____</td> <td style="text-align:center;">+0.15 dB</td> </tr> <tr> <td style="text-align:center;">Step 38</td> <td style="text-align:center;">Step 39</td> <td></td> <td></td> <td></td> </tr> <tr> <td style="text-align:center;">_____ dB</td> <td style="text-align:center;">_____ dB</td> <td style="text-align:center;">-0.15 dB</td> <td style="text-align:center;">_____</td> <td style="text-align:center;">+0.15 dB</td> </tr> <tr> <td style="text-align:center;">Step 45 + Step 50</td> <td style="text-align:center;">Step 46 + Step 51</td> <td></td> <td></td> <td></td> </tr> <tr> <td style="text-align:center;">_____ dB</td> <td style="text-align:center;">_____ dB</td> <td style="text-align:center;">-0.15 dB</td> <td style="text-align:center;">_____</td> <td style="text-align:center;">+0.15 dB</td> </tr> <tr> <td style="text-align:center;">Step 48 + Step 50</td> <td style="text-align:center;">Step 49 + Step 51</td> <td></td> <td></td> <td></td> </tr> <tr> <td style="text-align:center;">_____ dB</td> <td style="text-align:center;">_____ dB</td> <td style="text-align:center;">-0.15 dB</td> <td style="text-align:center;">_____</td> <td style="text-align:center;">+0.15 dB</td> </tr> </table>	Power Meter Reading	Noise Figure Meter Reading				Step 35	Step 36				_____ dB	_____ dB	-0.15 dB	_____	+0.15 dB	Step 38	Step 39				_____ dB	_____ dB	-0.15 dB	_____	+0.15 dB	Step 45 + Step 50	Step 46 + Step 51				_____ dB	_____ dB	-0.15 dB	_____	+0.15 dB	Step 48 + Step 50	Step 49 + Step 51				_____ dB	_____ dB	-0.15 dB	_____	+0.15 dB			
	Power Meter Reading	Noise Figure Meter Reading																																															
	Step 35	Step 36																																															
	_____ dB	_____ dB	-0.15 dB	_____	+0.15 dB																																												
Step 38	Step 39																																																
_____ dB	_____ dB	-0.15 dB	_____	+0.15 dB																																													
Step 45 + Step 50	Step 46 + Step 51																																																
_____ dB	_____ dB	-0.15 dB	_____	+0.15 dB																																													
Step 48 + Step 50	Step 49 + Step 51																																																
_____ dB	_____ dB	-0.15 dB	_____	+0.15 dB																																													
4-9	INSTRUMENT NOISE FIGURE PERFORMANCE TEST																																																
	Frequency																																																
	10 MHz		_____	7.03 FdB																																													
	110 MHz		_____	7.33 FdB																																													
	210 MHz		_____	7.63 FdB																																													
	310 MHz		_____	7.93 FdB																																													
	410 MHz		_____	8.23 FdB																																													
	510 MHz		_____	8.53 FdB																																													
	610 MHz		_____	8.83 FdB																																													
	710 MHz		_____	9.13 FdB																																													
	810 MHz		_____	9.43 FdB																																													
	910 MHz		_____	9.73 FdB																																													
	1010 MHz		_____	10.03 FdB																																													
	1110 MHz		_____	10.33 FdB																																													
	1210 MHz		_____	10.63 FdB																																													
	1310 MHz		_____	10.93 FdB																																													
1410 MHz		_____	11.23 FdB																																														
1510 MHz		_____	11.53 FdB																																														



4-22 This Page Intentionally Left Blank

Table 4-2. Performance Test Record (1 of 3)

Hewlett-Packard Company Model HP 8970B Option 020 Noise Figure Meter Serial Number _____		Tested by _____ Date _____		
Para. No.	Test	Results		
		Min.	Actual	Max.
4-5	TUNING ACCURACY PERFORMANCE TEST Tuned Frequency 20 MHz 100 MHz 300 MHz 500 MHz 1000 MHz 1300 MHz 1600 MHz 1800 MHz 2000 MHz 2047 MHz	18.8 MHz 98 MHz 296 MHz 494 MHz 994 MHz 1294 MHz 1594 MHz 1794 MHz 1994 MHz 2041 MHz	_____ _____ _____ _____ _____ _____ _____ _____ _____ _____ _____	21.2 MHz 102 MHz 304 MHz 506 MHz 1006 MHz 1306 MHz 1606 MHz 1806 MHz 2006 MHz 2053 MHz
4-6	INPUT SWR PERFORMANCE TEST +20 dB Input Gain Setting Frequency _____ MHz _____ MHz +10 dB Input Gain Setting Frequency _____ MHz _____ MHz 0 dB Input Gain Setting Frequency _____ MHz _____ MHz		_____ _____ _____ _____ _____	-11.73 dB < 1600 MHz -9.63 dB < 2047 MHz -11.73 dB < 1600 MHz -9.63 dB < 2047 MHz -11.73 dB < 1600 MHz -9.63 dB < 2047 MHz

Table 4-2. Performance Test Record (2 of 3)

Para. No.	Test	Results		
		Min.	Actual	Max.
4-7	NOISE FIGURE RANGE AND ACCURACY PERFORMANCE TEST		Difference	
	Step 9 — Step 10 ²	-0.00053	_____	+0.00054
	Step 12 — Step 13 ²	-0.00589	_____	+0.00603
	Step 9 — Step 10 ²	-0.04922	_____	+0.05037
	Step 15 — Step 16 ²	-0.20487	_____	+0.20964
	Step 9 — Step 10 ²	-0.69706	_____	+0.71330
	Step 18 — Step 19 ²	-0.69706	_____	+0.71330
	Step 9 — Step 10 ²			
	Step 21 — Step 22 ²			
	Step 9 — Step 10 ²			
	Step 24 — Step 25 ²			
Step 18 — Step 19 ²				
Step 27 — Step 28 ²				
4-8	GAIN MEASUREMENT UNCERTAINTY PERFORMANCE TEST			
	Power Meter Reading	Noise Figure Meter Reading		
	Step 35	Step 36		
	_____ dB — _____ dB		-0.15 dB	+0.15 dB
	Step 38	Step 39		
	_____ dB — _____ dB		-0.15 dB	+0.15 dB
Step 45 + Step 50	Step 46 + Step 51			
_____ dB — _____ dB		-0.15 dB	+0.15 dB	
Step 48 + Step 50	Step 49 + Step 51			
_____ dB — _____ dB		-0.15 dB	+0.15 dB	

Table 4-2. Performance Test Record (3 of 3)

Para. No.	Test	Results		
		Min.	Actual	Max.
4-9	INSTRUMENT NOISE FIGURE PERFORMANCE TEST			
	Frequency			
	10 MHz		_____	7.02 FdB
	110 MHz		_____	7.22 FdB
	210 MHz		_____	7.42 FdB
	310 MHz		_____	7.62 FdB
	410 MHz		_____	7.82 FdB
	510 MHz		_____	8.02 FdB
	610 MHz		_____	8.22 FdB
	710 MHz		_____	8.42 FdB
	810 MHz		_____	8.62 FdB
	910 MHz		_____	8.82 FdB
	1010 MHz		_____	9.02 FdB
	1110 MHz		_____	9.22 FdB
	1210 MHz		_____	9.42 FdB
	1310 MHz		_____	9.62 FdB
	1410 MHz		_____	9.82 FdB
	1510 MHz		_____	10.02 FdB
	1610 MHz		_____	10.22 FdB
	1710 MHz		_____	10.42 FdB
1810 MHz		_____	10.62 FdB	
1910 MHz		_____	10.82 FdB	
2010 MHz		_____	11.09 FdB	



4-26 Thru 4-28 Intentionally Left Blank

HP 8971B/C PERFORMANCE TESTS

4-12. INTRODUCTION

The procedures that follow test the electrical performance of the Noise Figure Test Set using the appropriate specifications of Section I as performance standards. All tests can be performed without access to the interior of the instrument.

4-13. Equipment Required

Equipment required for the performance tests is listed before each of the tests.

4-14. Performance Test Record

Results of the performance tests may be recorded in the Performance Test Record at the end of this section. Results recorded at incoming inspection can be used for comparison in periodic maintenance and troubleshooting and after repairs or adjustments.

4-15. Calibration Cycle

The HP 8971B and the HP 8971C require periodic verification of performance. Depending on the use and environmental conditions, the instrument should be checked using the performance tests at least once a year.

4-16. Performance Test Procedures

Perform the tests in the order given and record the data in the Performance Test Record and/or in the data spaces provided within the text.

NOTE

All specifications of performance are certified only in the temperature range of +10 °C to +40 °C.

It is assumed that the person performing the tests understands how to use the specified test equipment. Equipment settings, other than those for the instrument, are stated in general terms. It is also assumed that the person performing the tests will supply whatever cables, connectors, and adapters which are necessary.

PERFORMANCE TESTS

4-17. INPUT SWR PERFORMANCE TESTS

NOTE

This SWR test applies to HP 8971Cs Standard or Option 001. For HP 8971Cs Option 002 and HP 8971Bs, you may test SSB 1 and 2 (up to 2.4 GHz) with this test, but you must use the test that follows this test for SSB 3.

Specification

SWR Test	Specification	Range
HP 8971C Std. and Opt. 001	2.25:1	10 MHz – 18 GHz
	2.5:1	18 – 26.5 GHz
HP 8971C Opt. 002	1.5:1	10 – 1600 MHz
	2:1	1.6 – 2.4 GHz
HP 8971B	1.5:1	10 – 1600 MHz
	2:1	1.6 – 2.4 GHz

Description An input SWR test is performed for each of the three single sideband modes of operation.

Equipment

- 10 dB Attenuator HP 8493C opt 010
- Signal Generator HP 8340B/41B
- Scalar Network Analyzer ... HP 8757A
- Power Splitter HP 11667B
- Detector HP 85025B
- Directional Bridge HP 85027B
- SMA-male Coaxial Short/
Open HP 85037-60001
- System See the section on Programming the System LO.
- Noise Source HP 346B/C

NOTE

You will test the SWR in three ranges of operation. It is not necessary to set the YIG filter for a SWR test on the HP 8971C Standard or Option 001.

5. On the HP 8757A, press **CAL**.
6. A menu will appear. Press the **SHORT/OPEN** softkey. The HP 8757A menu will prompt you to connect a short (see Figure 4-6). Follow the directions on the menu. The short and open calibrations will only take a few milliseconds each.
7. Hook the HP 8971C back up to the SWR bridge.
8. Set the average to **AVG ON** on the HP 8757A, and set to 32 for smoother trace.
9. On the HP 8970B, press **PRESET**.
10. To establish the HP 8970B as system controller:
 - a. Press: **4 6 . 0 SPECIAL FUNCTION**
 - b. Press: **4 8 . 0 SPECIAL FUNCTION**
11. To control the system LO press: **4 1 . 3 SPECIAL FUNCTION** (41.3 is for an HP 8673B. Use pullout #1 on the HP 8970B to find the correct special function for another system LO.)
12. To control the HP 8971C (or HP 8971B): Press: **1 . 5 SPECIAL FUNCTION**
13. If your HP 8971C is an option 001, set the power of the system LO to +1 dBm using special function 42.5.
 - a. Press: **4 2 . 5 SPECIAL FUNCTION**
 - b. Press: **1 ENTER**
14. On the HP 8970B, press: **FREQUENCY 8 0 0 ENTER**
15. Set the HP 8757A for SWR format and measure by reading the **MAX** marker level. Press: **MAX**. Wait, then press **MAX** again to record the worst case SWR: _____
16. Disconnect the directional bridge from the 8971C and set the HP 8340B to a start frequency of 1600 MHz and a stop frequency of 2400 MHz.
17. On the HP 8757A, press **CAL**.
18. A menu will appear. Press the **SHORT/OPEN** softkey. The HP 8757A menu will prompt you to connect a short (see Figure 4-6). Follow the directions on the menu. The short and open calibrations will only take a few milliseconds each.
19. Hook the HP 8971C back up to the SWR bridge.
20. On the HP 8970B, press: **FREQUENCY 2 0 0 0 ENTER**
21. Set the average to **AVG ON** on the HP 8757A.
22. Press the **CURSOR** key and measure the worst case SWR by reading the **MAX** marker level. Record the worst case SWR: _____

NOTE

If you have an HP 8971C option 002 or an HP 8971B, do not continue this test. Move on to the next SWR test to measure SSB 3.

23. Disconnect the directional bridge from the 8971C and set the HP 8340B to a start frequency of 2400 MHz and a stop frequency of 26500 MHz.
24. On the HP 8757A, press **CAL**.
25. A menu will appear. Press the **SHORT/OPEN** softkey. The HP 8757A menu will prompt you to connect a short (see Figure 4-6). Follow the directions on the menu. The short and open calibrations will only take a few milliseconds each.
26. Hook the HP 8971C back up to the SWR bridge.
27. Set the average to **AVG ON** on the HP 8757A.
28. Press the **CURSOR** key and measure by reading the **MAX** marker level. Record the worst case SWR: _____

NOTE

If the recorded worst case SWR meets the specifications of the 2.4 to 18GHz spec, this test is complete. If it does not meet the 2.4 to 18GHz spec but meets the 18 to 26.5GHz spec, then the worse case SWR below 18GHz must be found using the dial to determine if it meets spec.

Table 4-3. HP 8971B/C SWR Test Results

Noted Frequencies	Test Result	Maximum Std and Option 001	Maximum Option 002	Maximum HP 8971B
10 MHz to 1600 MHz	Worst Case	2.25:1	1.5:1	1.5:1
		2.25:1	1.5:1	1.5:1
		2.25:1	1.5:1	1.5:1
		2.25:1	1.5:1	1.5:1
1.6 GHz to 2.4 GHz	Worst Case	2.25:1	2:1	2:1
		2.25:1	2:1	2:1
		2.25:1	2:1	2:1
		2.25:1	2:1	2:1
2.4 GHz to 18 GHz	Worst Case	2.25:1	NA	NA
		2.25:1	NA	NA
		2.25:1	NA	NA
		2.25:1	NA	NA
18 GHz to 26.5 GHz	Worst Case	2.5:1	NA	NA
		2.5:1	NA	NA
		2.5:1	NA	NA
		2.5:1	NA	NA

PERFORMANCE TESTS

4-18. INPUT SWR PERFORMANCE TESTS

NOTE

This SWR test applies to HP 8971C Models with Option 002, and to HP 8971B models. It covers only frequencies in SSB 3, 2400 to 18000 MHz in the HP 8971B, and 2400 to 26500 MHz in the HP 8971C Option 002. Testing lower bands can be done easily using the preceding SWR test.

Specification

SWR Test	Specification	Range
HP 8971C Opt 002	2:1	2.4 - 18 GHz
	3:1	18 - 26.5 GHz
HP 8971B	2:1	2.4 - 18 GHz

Description

An input SWR test is performed in SSB 3 of the HP 8971C OPTION 002 and the HP 8971B.

Equipment

- 10 dB Attenuator HP 8493C option 010
- Signal Generator HP 8340B/41B
- Scalar Network Analyzer HP 8757A
- Power Splitter HP 11667B
- Detector HP 85025B
- Directional Bridge HP 85027B
- SMA-male Coaxial Short/Open HP 85037-60001
- LO Input Cable HP 08971-60126
- IF Output Cable HP 11793-60006
- System LO See the section on Programming the System LO.
- Noise Source HP 346B/C

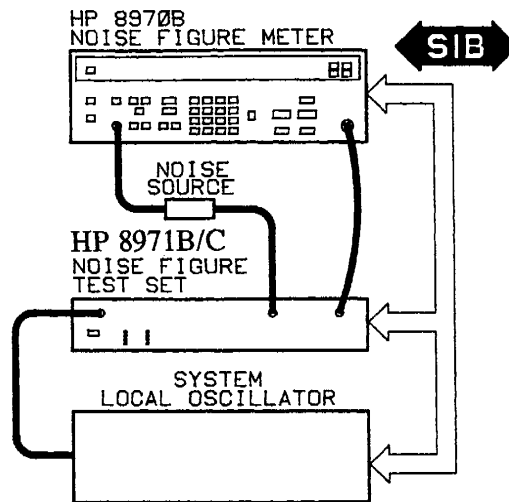

Figure 4-7. Fine Peak YIG Test Setup

Procedure

1. Power up all equipment and allow to warm up for one hour.
2. On the HP 8970B, press **PRESET**.
3. Set up the HP 8970B as the system controller.
 - a. Press: **4 6 . 0** **SPECIAL FUNCTION**
 - b. Press: **4 8 . 0** **SPECIAL FUNCTION**
4. On the HP 8970B, press **1 . 5** **SPECIAL FUNCTION**.
5. To control the system LO, press **4 1 . 3** **SPECIAL FUNCTION**. (41.3 is for a HP 8673B. Use pullout #1 on the 8970B to find the correct special function for another system LO.)

NOTE

Make sure that the correct ENR table for the noise source used is entered in the HP 8970B. A preamplifier connected between the noise source and the HP 9871B/C RF input may be necessary to allow the YIG to be peaked above 18 GHz (Typically above 24 GHz).

6. If your HP 8971C is an option 001, use special function 42.5 to set the LO power to +1 dBm.
 - a. Press: **4 2 . 5** **SPECIAL FUNCTION**
 - b. Press: **1** **ENTER**
 - c. Press: **4 2 . 4** **SPECIAL FUNCTION**
 - d. Press: **2 6 5 0 0** **ENTER**
7. Fine Peak the YIG at frequencies to be tested.
 - a. Press: **START FREQ**
 - b. Press: **2 5 0 0** **ENTER**

- c. Press: **STOP FREQ**
- d. Press: **2 6 5 0 0 ENTER** (18000 for HP 8971B)
- e. Press: **STEP SIZE**
- f. Press: **5 0 0 ENTER**
- g. Press: **3 6 . 3 SPECIAL FUNCTION**
- h. Wait until fine peak finishes before continuing.

NOTE

The fine peak above checks only the frequencies that are stepped through. If you have other frequencies of specific interest to your application, fine peak at those frequencies also. Before proceeding, remove the preamplifier if used for fine peaking the YIG.

8. Set up the equipment as shown in the following figure.

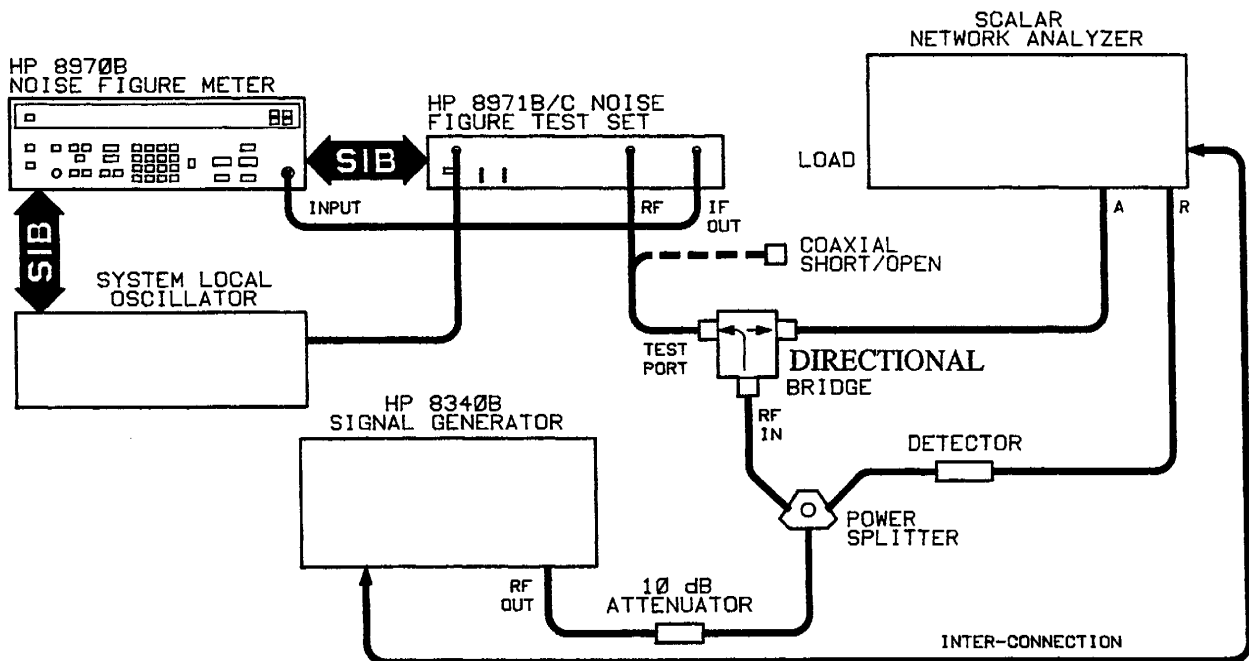

Figure 4-8. SWR Test Setup

9. The interconnections between the HP 8757A and the HP 8340B are as follows:
 - a. Connect the HP 8340B Pulse Modulation Input to the HP 8757A Modulation Drive.
 - b. Connect the HP 8340B Sweep Output to the HP 8757A Sweep In 0-10V.
 - c. Connect the HP 8340B Z-Axis Blank/MKRS to the HP 8757A Pos Z Blank.
 - d. Connect the HP 8340B Stop SWP In/Out to the HP 8757A Stop Sweep.
 - e. Connect an HPIB cable from the HPIB connector on the HP 8340B to the HP 8757S System Interface connector on the HP 8757A.

NOTE

Keep all connectors clean and keep the number of adapters to a minimum.

10. Preset the HP 8757A Scalar Network Analyzer. Turn Channel 2 OFF. Set the SCALE to 10 dB/div. Set the measurement mode to A/R. Set the display for MEAS—MEM
11. On the HP 8340B(microwave test station) set the output power to -5 dBm. Set Pulse Modulation to on. Set the Sweep Time to 100 ms. Set Sweep Mode to continuous. Set the start frequency to 2400 MHz and the stop frequency to 2600 MHz.
12. On the HP 8757A, press **CAL**.
13. A menu will appear. Press the **SHORT/OPEN** softkey. The HP 8757A menu will prompt you to connect a short (see Figure 4-7). Follow the directions on the menu. The short and open calibrations will only take a few milliseconds each.
14. Hook the HP 8971C back up to the SWR bridge.
15. Set the average to ON on the HP 8757A, and to 32 for smoother trace.
 - a. Press: **AVG**
 - b. Press: **AVG ON** softkey so the the AVG is set to on.
 - c. Press: **AVG FACTOR** softkey
 - d. Press: **3 2 ENT**
16. Set the HP 8757A for SWR format and measure by reading the marker level.
 - a. Press: **CURSOR**
 - b. Check to see if the cursor is set to on. If it is not press the **CURSOR ON** softkey so that the cursor is set.
 - c. Press: **SWR dB** softkey so that the display shows SWR.
17. Set the HP 8970B to a frequency of 2500 MHz.
18. Measure SWR and record in the table that follows. Use the **MIN** softkey to adjust the cursor to the low point.
19. Set the HP 8340B to the next 200 MHz sweep. This will be 16900 to 17100 MHz. (± 100 MHz from the next frequency to be measured.)
20. Press **CAL** on HP 8757A. Press the SHORT\OPEN key. Follow directions on the display.
21. On the HP 8757A, turn the AVG back ON.
22. Reconnect the HP 8971C to the SWR bridge.
23. Set the HP 8970B to the next frequency(17000 MHz, 26500 MHz).
24. Set the HP 8757A for SWR readout and measure by reading the marker level. Use the **MIN** softkey to adjust the cursor. Record the SWR in the table that follows.
25. Repeat steps 20 through 25 for the last frequency, 26500 MHz.

NOTE

Other frequencies at multiples of 500 MHz (2500 MHz and above) can be tested. Test any multiple that might be of interest. Repeat steps 20 through 25 for each additional frequency.

Table 4-4. HP 8971B/C SWR Test Results

Noted Frequencies	Test Result	Maximum Option 002	Maximum HP 8971B
2.4 GHz to 18 GHz	Worst Case	2:1	2:1
		2:1	2:1
		2:1	2:1
		2:1	2:1
18 GHz to 26.5 GHz	Worst Case	3:1	NA
		3:1	NA
		3:1	NA
		3:1	NA

PERFORMANCE TESTS

4-19. NOISE FIGURE TEST

NOTE

This Noise Figure Test applies to all HP 8971C instruments. This test does not apply to the HP 8971B. The Noise Figure Gain Test (4-20), which follows this test, applies to the HP 8971B.

Specification

Mode	Specification	Conditions
<i>Noise Figure</i>		
HP 8971C Std and Opt 001		
	< = 18 dB	10-30 MHz
	< = 13 dB	30-100 MHz
	< = 10 dB	0.1-12 GHz
	< = 11.5 dB	12-18 GHz
	< = 14.5 dB	18-26.5 GHz
Opt 002 only		
	< = 5.4 dB	10 MHz-1.6 GHz
	< = 28 dB	1.6-2.4 GHz
	< = 26 dB	2.4-15 GHz
	< = 28 dB	15-18 GHz
	< = 28 dB typical	18-22 GHz
	< = 32 dB typical	22-26.5 GHz

Description

Noise Figure is tested in each of the three SSB test ranges:

- a) SSB1 10 MHz to 1600 MHz
- b) SSB2 1.6 GHz to 2.4 GHz
- c) SSB3 2.4 GHz to 26.5 GHz

Results of all tests are compared with specified values to verify that the HP 8971C meets specifications.

Equipment

Noise Figure Meter HP 8970B
 Signal Generator See the Section on Programming the System LO.
 Noise Source HP 346B/C

Procedure

10 to 1600 MHz

1. Connect the Noise Figure Calibration Setup.

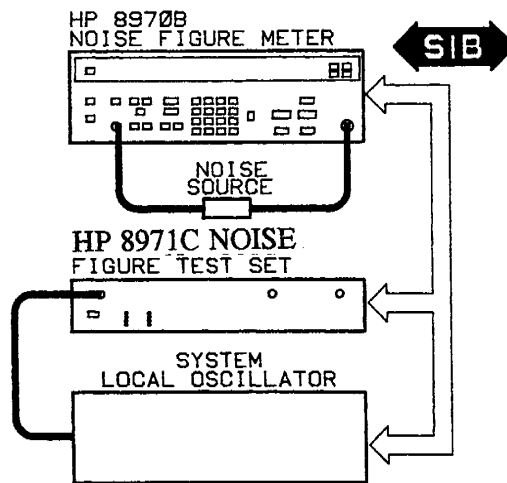

Figure 4-9. Noise Figure Calibration Test Setup

2. Warm up equipment for sixty minutes.

NOTE

Make sure that the correct ENR table for the noise source used is entered in the HP 8970B.

3. On the HP 8970B, press **PRESET**
4. Increase smoothing to 32. Press **INCREASE** five times.
5. Prepare the Noise Figure Measurement System for use.
 - a. Press: **4 6 . 0 SPECIAL FUNCTION**
 - b. Press: **4 8 . 0 SPECIAL FUNCTION**
 - c. Press: **4 5 . 1 SPECIAL FUNCTION**
 - d. Press: **1 . 5 SPECIAL FUNCTION**
 - e. Press: **4 1 . 4** (See Pull Out Card 1 on the 8970B if you are not using an HP 8340B)
 - f. Press: **SPECIAL FUNCTION**
 - g. If you have an option 001, press: **4 2 . 5 SPECIAL FUNCTION** and **1 ENTER**
6. Press: **4 2 . 4 SPECIAL FUNCTION**
7. Press: **2 6 5 0 0 ENTER**
8. Set up the HP 8970B to calibrate 10 and 100 MHz.
 - a. Press: **START FREQ**
 - b. Press: **1 0 ENTER**

- c. Press: **STOP FREQ**
- d. Press: **1 0 0 ENTER**
- e. Press: **STEP SIZE**
- f. Press: **9 0 ENTER**
9. Press: **CALIBRATE CALIBRATE**
10. Wait for the calibration to finish before proceeding.
11. Connect the equipment as in the following figure.

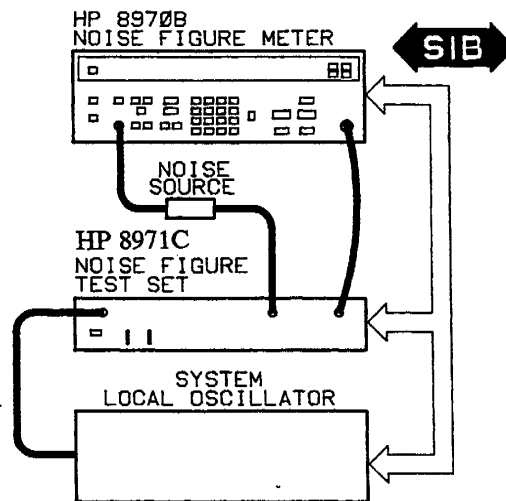

Figure 4-10. Noise Figure Test Setup

12. Press: **NOISE FIGURE AND GAIN**.
13. Use the **START FREQ** and **STOP FREQ** keys to view 10 and 100 MHz. Measure the noise figure at 10 and 100 MHz.
14. Record results in the table that follows.
15. Reconnect the Noise Figure Calibration Setup. (Figure 4-9)
16. Set up the HP 8970B to calibrate for 200 to 1600 MHz.
 - a. Press: **START FREQ**
 - b. Press: **2 0 0 ENTER**
 - c. Press: **STOP FREQ**
 - d. Press: **1 6 0 0 ENTER**
 - e. Press: **STEP SIZE**
 - f. Press: **1 0 0 ENTER** (Ignore E21)
17. Press: **CALIBRATE CALIBRATE**

18. Wait for the calibration to finish before proceeding.
19. Reconnect the Noise Figure Test Setup.
20. Measure the noise figure from 200 to 1600 MHz.
21. Use the fixed frequency **UP** and **DOWN** keys to measure the desired frequency.
 - a. Press: **FREQ**
 - b. Press: **2 0 0 ENTER**
 - c. Press: **FREQ INCR**
 - d. Press: **1 0 0 ENTER**
22. Record the results in the following table.

Table 4-5. HP 8971C SSB1 Noise Figure Test Results

Frequency	Noise Figure Specified Std and Opt 001	Noise Figure Specified Opt 002	Noise Figure Actual
10 MHz	18 dB	5.4 dB	_____
100 MHz	10 dB	5.4 dB	_____
200 MHz	10 dB	5.4 dB	_____
300 MHz	10 dB	5.4 dB	_____
400 MHz	10 dB	5.4 dB	_____
500 MHz	10 dB	5.4 dB	_____
600 MHz	10 dB	5.4 dB	_____
700 MHz	10 dB	5.4 dB	_____
800 MHz	10 dB	5.4 dB	_____
900 MHz	10 dB	5.4 dB	_____
1000 MHz	10 dB	5.4 dB	_____
1100 MHz	10 dB	5.4 dB	_____
1200 MHz	10 dB	5.4 dB	_____
1300 MHz	10 dB	5.4 dB	_____
1400 MHz	10 dB	5.4 dB	_____
1500 MHz	10 dB	5.4 dB	_____
1600 MHz	10 dB	5.4 dB	_____

Procedure**1600 to 2400 MHz**

1. Connect equipment as shown in the Noise Figure Calibration Setup.
2. Warm up equipment for sixty minutes.

NOTE

Make sure that correct ENR calibration tables for Noise Source used are entered in HP 8970B. (See HP 8970B Operating Manual).

3. Press: **PRESET**
4. Press: **4 6 . 0 SPECIAL FUNCTION**
5. Press: **4 8 . 0 SPECIAL FUNCTION**
6. If you have an option 001, press: **4 2 . 5 SPECIAL FUNCTION** and **1 ENTER**.
7. Enable communication with the HP 8971C in modes 1.5 to 1.9
 - a. Press **4 5 . 0**
 - b. Press: **SPECIAL FUNCTION**
8. Enable Local Oscillator for fixed IF of 700 MHz
 - a. Press: **1 . 3 SPECIAL FUNCTION**
 - b. Press: **3 . 0 SPECIAL FUNCTION**
 - c. Press: **7 0 0 ENTER**

NOTE

Ignore ERROR 42 whenever it appears during this test procedure.

9. Set for lower sideband measurement and select the correct LO program (SPECIAL FUNCTION 41.X)
 - a. Press: **2 . 1 SPECIAL FUNCTION**
 - b. Press: **4 1 . 4** (See Pull Out Card 1 on the 8970B if you are not using a HP 8340B)
 - c. Press: **SPECIAL FUNCTION**
10. Increase Smoothing to 32
 - a. Press: **INCREASE**
 - b. Press: **INCREASE**
 - c. Press: **INCREASE**
 - d. Press: **INCREASE**
 - e. Press: **INCREASE**
11. Calibrate the HP 8970B
 - a. Press: **CALIBRATE**
 - b. Press: **CALIBRATE**
12. Wait for the calibration to finish before proceeding.
13. Reconnect the Noise Figure Test Setup.

14. Enable mode 1.5 and set the Noise Figure Meter frequency to 2000 MHz. This puts the Noise Figure Test Set into SSB2.
 - a. Press: **1** **.** **5** **SPECIAL FUNCTION**
 - b. Press: **FREQUENCY**
 - c. Press: **2** **0** **0** **0** **ENTER**
 - d. Press: **1** **.** **3** **SPECIAL FUNCTION**
15. To observe results, set up a 100 MHz increment and use the fixed freq **▲** key.
 - a. Press: **START FREQ**
 - b. Press: **1** **7** **0** **0** **ENTER**
 - c. Press: **FREQ INCR**
 - d. Press: **1** **0** **0** **ENTER**
 - e. Press: **NOISE FIGURE AND GAIN**
16. Record values of noise figure in the following table using the fixed freq **▲** key to step to each new frequency.

Table 4-6. HP 9871C SSB2 Noise Figure Test Results

Frequency	Noise Figure Specified Std and Opt 001	Noise Figure Specified Opt 002	Noise Figure Actual
1700 MHz	≤10 dB	≤25 dB	_____
1800 MHz	≤10 dB	≤25 dB	_____
1900 MHz	≤10 dB	≤25 dB	_____
2000 MHz	≤10 dB	≤25 dB	_____
2100 MHz	≤10 dB	≤25 dB	_____
2200 MHz	≤10 dB	≤25 dB	_____
2300 MHz	≤10 dB	≤25 dB	_____
2400 MHz	≤10 dB	≤25 dB	_____

Procedure

2.4 to 26.5 GHz

1. Set up instruments as shown in the Noise Figure Test Setup.
2. Turn on power to the instruments and allow a warm up of one hour.
3. Preset the HP 8970B and select the correct LO program (SPECIAL FUNCTION 41.X)
 - a. Press: **PRESET**
 - b. Press: **4** **6** **.** **0** **SPECIAL FUNCTION**
 - c. Press: **4** **8** **.** **0** **SPECIAL FUNCTION**
 - d. Press: **4** **2** **.** **4** **SPECIAL FUNCTION**

- e. Press: **2 6 5 0 0 ENTER**
- f. Press: **4 1 . 4** (See Pull Out Card 1 on the 8970B if you are not using a HP 8340B.)
- g. Press: **SPECIAL FUNCTION**
4. If you have an option 001, Press: **4 2 . 5 SPECIAL FUNCTION** and **1 ENTER**

NOTE

The instrument responds slowly to some commands. Make sure that each time a key is pressed the instrument recognizes it and responds.

Make sure that the correct ENR table for the noise source used is entered in the HP 8970B.

5. Enable communication with the HP 8971C in modes 1.5–1.9
- a. Press: **4 5 . 0**
- b. Press: **SPECIAL FUNCTION**
6. Enable mode 1.5
- a. Press: **1 . 5**
- b. Press: **SPECIAL FUNCTION** (Ignore E28)
7. Set Frequency points to calibrate the YIG filter
- a. Press: **START FREQ**
- b. Press: **2 5 0 0 ENTER**
- c. Press: **STOP FREQ**
- d. Press: **2 6 5 0 0 ENTER**
- e. Press: **STEP SIZE**
- f. Press: **1 0 0 0 ENTER**
8. Fine peak the YIG filter: **3 6 . 3 SPECIAL FUNCTION**
9. After "8971 CAL" disappears from the INSERTION GAIN and NOISE FIGURE displays, enable control of the YIG filter in mode 1.3 (this is accomplished by modifying a special RAM location) Ignore E23 if it appears.
- a. Press: **9 3 . 1 SPECIAL FUNCTION**
- b. Press: **6 5 4 5 8 ENTER**
- c. Press: **9 3 . 3 SPECIAL FUNCTION**
- d. Write down the number in the HP 8970B display. _____
- e. Press: **9 3 . 1 SPECIAL FUNCTION**
10. Key in the number recorded above Press: **ENTER**
- a. Press: **9 3 . 2 SPECIAL FUNCTION**
- b. Press: **1 6 ENTER**
- c. Press: **1 . 3 SPECIAL FUNCTION**
11. Set measurement frequency parameters

- a. Press: **FREQUENCY**
 - b. Press: **2 5 0 0 ENTER**
 - c. Press: **FREQ INCR**
 - d. Press: **1 0 0 0 ENTER**
12. Fix Intermediate Frequency (IF) to 450 MHz.
- a. Press: **3 . 0 SPECIAL FUNCTION**
 - b. Press: **4 5 0 ENTER**
13. Set smoothing to 32
- a. Press: **INCREASE**
 - b. Press: **INCREASE**
 - c. Press: **INCREASE**
 - d. Press: **INCREASE**
 - e. Press: **INCREASE**
14. Select Lower Sideband: Press: **2 . 1 SPECIAL FUNCTION**
15. Reconnect the Noise Figure Calibration Setup.
- a. Press: **CALIBRATE**
 - b. Press: **CALIBRATE**
 - c. Wait for the calibration to finish before proceeding.
16. Reconnect the system as shown in the Noise Figure Test Setup.
17. Take measurement at 2500 MHz
- a. Press: **NOISE FIGURE AND GAIN**
 - b. Record results in the table that follows.
18. To make the rest of the measurements:
- a. Press fixed freq **▲** key
 - b. Record Noise Figure for each frequency.

Table 4-7. HP 8971C SSB3 Noise Figure Test Results

Frequency	Noise Figure Specified Std and Opt 001	Noise Figure Specified Opt 002	Noise Figure Actual
2500 MHz	≤ 10 dB	≤ 26 dB	
3500 MHz	≤ 10 dB	≤ 26 dB	
4500 MHz	≤ 10 dB	≤ 26 dB	
5500 MHz	≤ 10 dB	≤ 26 dB	
6500 MHz	≤ 10 dB	≤ 26 dB	
7500 MHz	≤ 10 dB	≤ 26 dB	
8500 MHz	≤ 10 dB	≤ 26 dB	
9500 MHz	≤ 10 dB	≤ 26 dB	
10500 MHz	≤ 10 dB	≤ 26 dB	
11500 MHz	≤ 10 dB	≤ 26 dB	
12500 MHz	≤ 11.5 dB	≤ 26 dB	
13500 MHz	≤ 11.5 dB	≤ 26 dB	
14500 MHz	≤ 11.5 dB	≤ 26 dB	
15500 MHz	≤ 11.5 dB	≤ 28 dB	
16500 MHz	≤ 11.5 dB	≤ 28 dB	
17500 MHz	≤ 11.5 dB	≤ 28 dB	
18500 MHz	≤ 14 dB	≤ 28 dB <i>typical</i>	
19500 MHz	≤ 14 dB	≤ 28 dB <i>typical</i>	
20500 MHz	≤ 14 dB	≤ 28 dB <i>typical</i>	
21500 MHz	≤ 14 dB	≤ 28 dB <i>typical</i>	
22500 MHz	≤ 14 dB	≤ 28 dB <i>typical</i>	
23500 MHz	≤ 14 dB	≤ 28 dB <i>typical</i>	
24500 MHz	≤ 14 dB	≤ 28 dB <i>typical</i>	
25500 MHz	≤ 14 dB	≤ 28 dB <i>typical</i>	

PERFORMANCE TESTS

4-20. IMAGE AND THIRD HARMONIC REJECTION TEST

NOTE

This performance test applies to HP 8971B instruments ONLY.

Specification

Mode	Specification	Conditions
SSB3	>20 dB	

Description

This test verifies the ability of the Noise Figure Test Set to reject unwanted responses to signals appearing at the image frequency or the third harmonic of the desired response. The HP 8971B provides rejection of these signals in SSB modes 2 and 3. The test consists of injecting signals at the appropriate frequency and using the HP 8970B as a measuring receiver. In SSB mode 2, the image will appear 1400 MHz above the desired response (700 MHz IF) and in SSB mode 3 the image will appear either 900 MHz above the desired signal (frequency <16.001 GHz) or 900 MHz below the desired signal (frequency >16 GHz). By design, the mixer in the HP 8971B rejects even harmonic responses and all odd responses which exceed 20 GHz, so it is not necessary to test all possible responses.

Equipment

- Noise Figure Measurement System . HP 8970B, HP 8971B and supported LO.
- Noise Source HP 346B/C
- Signal Generator HP 8340B
- Power Meter HP 436A
- Power Sensor HP 8484A/8481D

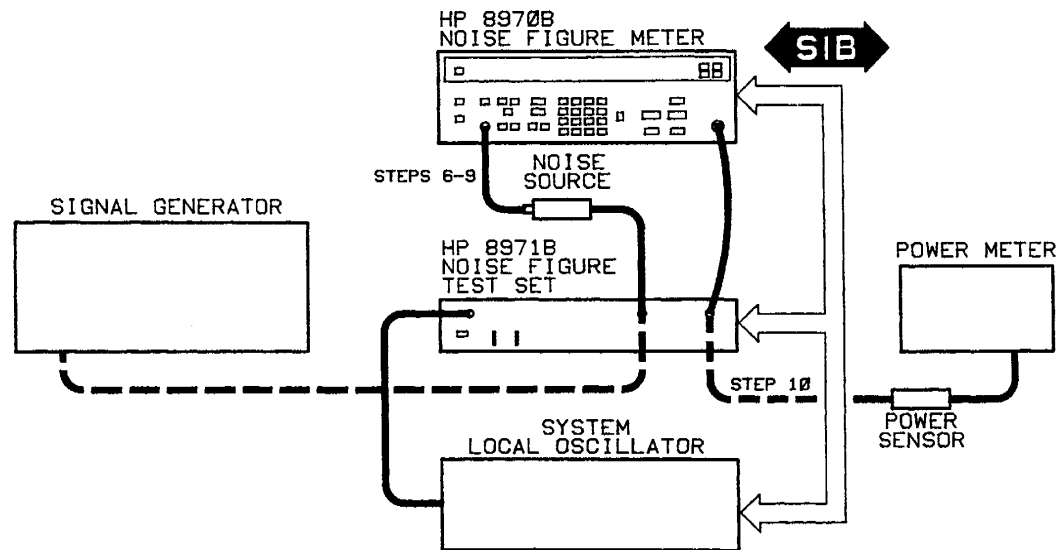

Figure 4-11. Image and Odd Harmonic Rejection Test Setup

Procedure

1. Connect equipment as shown above.
2. Select the proper system LO (41.0–41.4 SP)
 - a. Press: **4 1 . 3** (For HP 8673B only. For HP 8671B or 8672A use 41.2. For HP 8340B use 41.4)
 - b. Press: **SPECIAL FUNCTION**
3. Preset the Noise Figure Meter

Press: **PRESET**
4. Place system in mode 1.5.
 - a. Press: **1 . 5**
 - b. Press: **SPECIAL FUNCTION**
5. Set start, stop and step frequencies.
 - a. Press: **START FREQ**
 - b. Press: **4 0 0 0**
 - c. Press: **ENTER**
 - d. Press: **STOP FREQ**
 - e. Press: **1 8 0 0 0**
 - f. Press: **ENTER**
 - g. Press: **STEP SIZE**
 - h. Press: **2 0 0 0**

- i. Press: **ENTER**
6. Connect noise source to RF Input of HP 8971B.
7. Fine tune the HP 8971B YIG filter (4 to 18 GHz).
 - a. Press: **3 6 . 3**
 - b. Press: **SPECIAL FUNCTION**
 - c. Wait for "8971 CAL" to disappear from the INSERTION GAIN and NOISE FIGURE displays before proceeding to the next step.
8. Set Frequency to 2401 MHz (lowest SSB3 frequency).
 - a. Press: **FREQUENCY**
 - b. Press: **2 4 0 1**
 - c. Press: **ENTER**
9. Peak YIG filter.
 - a. Press: **3 6 . 4**
 - b. Press: **SPECIAL FUNCTION**
10. Connect the power meter to the Noise Figure Test Set IF OUTPUT. Connect the signal source to the HP 8971B RF INPUT. Set the signal source to the image frequency 3301 MHz. Adjust the signal source output level so that the power meter reads $-40 \text{ dBm} \pm 5 \text{ dBm}$. Connect The Noise Figure Test Set IF OUTPUT to the Noise Figure Meter RF INPUT.
11. Select Power Measurement Mode
 - a. Press: **9 . 1**
 - b. Press: **SPECIAL FUNCTION**
12. Set smoothing to 8
 - a. Press: **INCREASE**
 - b. Press: **INCREASE**
 - c. Press: **INCREASE**
13. Tune the HP 8970B to the first frequency in table 4-8.
14. Set RF attenuator auto range.
 - a. Press: **6 0**
 - b. Press: **SPECIAL FUNCTION**
15. Tune the signal generator to the same frequency as the HP 8970B and record the power reading from the HP 8970B in Table 4-8. It may be necessary to fine tune the frequency of the signal generator in order to obtain the maximum reading in the Noise Figure Meters Noise Figure display.
16. Set RF attenuator hold mode.
 - a. Press: **6 2**
 - b. Press: **SPECIAL FUNCTION**

17. Retune the signal generator to the image frequency and record the HP 8970B power reading in column 4 of Table 4-8. It may be necessary to fine tune the signal generator in order to obtain the maximum Noise Figure reading.
18. If applicable, tune the signal generator to the 3rd harmonic frequency shown in column 5 of the table. Record the HP 8970B power reading in column 6 of the table.
19. Tune the HP 8970B to the next frequency in Table 4-8 and repeat steps 15 through 18. Repeat this process until all frequencies in the table have been tested.

NOTE

It might be necessary to fine tune the source at each frequency to obtain the maximum reading.

Table 4-8. Power Reference, Image and Harmonic

Source and 8970 Freq (step 13)	Power Ref (step 15)	Image Freq (step 17)	Power Image (step 17)	3rd Harmonic (step 18)	Power Harmonic (step 18)
1601 MHz		3001 MHz		NA	NA
2401 MHz		3301 MHz		7203 MHz	
4000 MHz		4900 MHz		12000 MHz	
6000 MHz		6900 MHz		18000 MHz	
8000 MHz		8900 MHz		NA	NA
10000 MHz		10900 MHz		NA	NA
12000 MHz		12900 MHz		NA	NA
14000 MHz		14900 MHz		NA	NA
16000 MHz		16900 MHz		NA	NA
18000 MHz		17100 MHz		NA	NA

20. Compute the difference between the power readings of columns 2 and 4. This is the rejection in dB. Record this value in column 2 of the following table.
21. From the results in above table, compute the rejection by subtracting the image or harmonic power level from the reference. LIMIT >20 dB.

Table 4-9. HP 9871B Image and Third Harmonic Rejection

8970 Frequency	Image Rejection(dB) Col 2-Col 4	3rd Harmonic Rejection(dB) Col 2-Col 6	Specification
1601	_____	NA	> 20 dB
2401	_____	_____	> 20 dB
4000	_____	_____	> 20 dB
6000	_____	_____	> 20 dB
8000	_____	_____	> 20 dB
10000	_____	NA	> 20 dB
12000	_____	NA	> 20 dB
14000	_____	NA	> 20 dB
16000	_____	NA	> 20 dB
18000	_____	NA	> 20 dB

Table 4-10. Performance Test Record (1 of 6)

Hewlett-Packard Company

Tested by _____

Model HP 8971B/C Noise Figure Test Set

Serial Number _____

Date _____

**Table 4-10. Performance Test Record (1 of 5)
HP 8971B/C SWR Test Results**

Noted Frequencies	Test Result	Maximum Std. and Opt. 001	Maximum Opt. 002	Maximum HP 8971B
10 MHz to 1600 MHz				
Worst Case	_____	2.25:1	1.5:1	1.5:1
	_____	2.25:1	1.5:1	1.5:1
	_____	2.25:1	1.5:1	1.5:1
	_____	2.25:1	1.5:1	1.5:1
1.6 GHz to 2.4 GHz				
Worst Case	_____	2.25:1	2:1	2:1
	_____	2.25:1	2:1	2:1
	_____	2.25:1	2:1	2:1
	_____	2.25:1	2:1	2:1
2.4 GHz to 18 GHz				
Worst Case	_____	2.25:1	2:1	2:1
	_____	2.25:1	2:1	2:1
	_____	2.25:1	2:1	2:1
	_____	2.25:1	2:1	2:1
18 GHz to 26.5 GHz				
Worst Case	_____	2.5:1	3:1	NA
	_____	2.5:1	3:1	NA
	_____	2.5:1	3:1	NA
	_____	2.5:1	3:1	NA

**Table 4-10. Performance Test Record (2 of 5)
HP 8971C SSB1 Noise Figure Test Results**

Frequency	Noise Figure Specified Std and Opt 001	Noise Figure Specified Opt 002	Noise Figure Actual
10 MHz	18 dB	5.4 dB	_____
100 MHz	10 dB	5.4 dB	_____
200 MHz	10 dB	5.4 dB	_____
300 MHz	10 dB	5.4 dB	_____
400 MHz	10 dB	5.4 dB	_____
500 MHz	10 dB	5.4 dB	_____
600 MHz	10 dB	5.4 dB	_____
700 MHz	10 dB	5.4 dB	_____
800 MHz	10 dB	5.4 dB	_____
900 MHz	10 dB	5.4 dB	_____
1000 MHz	10 dB	5.4 dB	_____
1100 MHz	10 dB	5.4 dB	_____
1200 MHz	10 dB	5.4 dB	_____
1300 MHz	10 dB	5.4 dB	_____
1400 MHz	10 dB	5.4 dB	_____
1500 MHz	10 dB	5.4 dB	_____
1600 MHz	10 dB	5.4 dB	_____

*Table 4-10. Performance Test Record (3 of 5)
HP 8971C Noise Figure Test Results*

Frequency	Noise Figure Specified Std and Opt 001	Noise Figure Specified Opt 002	Noise Figure Actual
1700 MHz	≤10 dB	≤25 dB	_____
1800 MHz	≤10 dB	≤25 dB	_____
1900 MHz	≤10 dB	≤25 dB	_____
2000 MHz	≤10 dB	≤25 dB	_____
2100 MHz	≤10 dB	≤25 dB	_____
2200 MHz	≤10 dB	≤25 dB	_____
2300 MHz	≤10 dB	≤25 dB	_____
2400 MHz	≤10 dB	≤25 dB	_____

**Table 4-10. Performance Test Record(4 of 5)
HP 8971C SSB1 Noise Figure Test Results**

Frequency	Noise Figure Specified Std and Opt 001	Noise Figure Specified Opt 002	Noise Figure Actual
2500 MHz	≤ 10 dB	≤ 26 dB	
3500 MHz	≤ 10 dB	≤ 26 dB	
4500 MHz	≤ 10 dB	≤ 26 dB	
5500 MHz	≤ 10 dB	≤ 26 dB	
6500 MHz	≤ 10 dB	≤ 26 dB	
7500 MHz	≤ 10 dB	≤ 26 dB	
8500 MHz	≤ 10 dB	≤ 26 dB	
9500 MHz	≤ 10 dB	≤ 26 dB	
10500 MHz	≤ 10 dB	≤ 26 dB	
11500 MHz	≤ 10 dB	≤ 26 dB	
12500 MHz	≤ 11.5 dB	≤ 26 dB	
13500 MHz	≤ 11.5 dB	≤ 26 dB	
14500 MHz	≤ 11.5 dB	≤ 26 dB	
15500 MHz	≤ 11.5 dB	≤ 28 dB	
16500 MHz	≤ 11.5 dB	≤ 28 dB	
17500 MHz	≤ 11.5 dB	≤ 28 dB	
18500 MHz	≤ 14 dB	≤ 28 dB <i>typical</i>	
19500 MHz	≤ 14 dB	≤ 28 dB <i>typical</i>	
20500 MHz	≤ 14 dB	≤ 28 dB <i>typical</i>	
21500 MHz	≤ 14 dB	≤ 28 dB <i>typical</i>	
22500 MHz	≤ 14 dB	≤ 28 dB <i>typical</i>	
23500 MHz	≤ 14 dB	≤ 28 dB <i>typical</i>	
24500 MHz	≤ 14 dB	≤ 28 dB <i>typical</i>	
25500 MHz	≤ 14 dB	≤ 28 dB <i>typical</i>	

**Table 4-10. Performance Test Record (5 of 5)
HP 8971B Image and Third Harmonic Rejection**

HP 8970 Frequency	Image Rejection(dB) Col 2-Col 4	3rd Harmonic Rejection(dB) Col 2-Col 6	Specification
1601	_____	NA	> 20 dB
2401	_____	_____	> 20 dB
4000	_____	_____	> 20 dB
6000	_____	_____	> 20 dB
8000	_____	_____	> 20 dB
10000	_____	NA	> 20 dB
12000	_____	NA	> 20 dB
14000	_____	NA	> 20 dB
16000	_____	NA	> 20 dB
18000	_____	NA	> 20 dB



PERFORMANCE TESTS

4-21. NOISE FIGURE AND GAIN TEST (INCLUDES REPEATABILITY)

NOTE

This performance test applies to the HP 8971B instrument ONLY

Specification

Mode	Specification	Conditions
<i>Noise Figure</i>		
SSB1	≤ 5 dB	10 MHz-1.6 GHz
SSB2	≤ 25 dB	1.6-2.4 GHz
SSB3	≤ 23 dB	2.4-12 GHz
	≤ 24 dB	12-15 GHz
	≤ 28 dB	15-18 GHz
<i>Gain</i>		
SSB1	≥ -4 dB	10 MHz-1.6 GHz
SSB2	≥ 0 dB	1.6-2.4 GHz
SSB3	≥ 2 dB	2.4-12 GHz
	≥ 1 dB	12-15 GHz
	≥ -2 dB	15-18 GHz
<i>Gain Repeatability</i>	≤ 0.2 dB	

Description

Noise Figure is tested in each of the three SSB test ranges:

- a) SSB1 10 MHz to 1600 MHz
- b) SSB2 1.6 GHz to 2.4 GHz
- c) SSB3 2.4 GHz to 18 GHz
- d) DSB 2.4 GHz to 18 GHz

SSB1 mode is a pass through mode. A 3 dB attenuator in series with the path attenuates the signal passing through. In the SSB1 test the attenuator is tested at several frequencies and amplitudes for gain. Measurements are made with a signal generator and a power meter. The external 3 dB attenuator improves the match at the output of the signal generator. Also, the microwave relays are switched 10 times and the results are checked for repeatability.

The Noise Figure and Gain Test for SSB2 mode checks noise figure and gain in the frequency range of 1.6 GHz to 2.4 GHz. After the signal passes through a 3 dB attenuator it passes through a band pass filter and another 3 dB attenuator. It is then mixed with the local oscillator to produce a 700 MHz IF which is then amplified and sent to the noise figure meter. The microwave relays are switched 10 times and the results are checked for repeatability.

The Noise Figure and Gain Test of SSB3 mode checks noise figure and gain in the frequency range of 2.4 GHz to 18 GHz. After the signal passes through a 3 dB attenuator it passes through a YIG bandpass filter and through another 3 dB attenuator. It is then mixed with the local oscillator to produce a 450 MHz IF which is amplified and sent to the noise figure meter. The YIG bandpass filter is tuned to

the low, mid, and high ends of its frequency range to check repeatability. Also, the microwave relays are switched 10 times to check for repeatability.

The Noise Figure and Gain Test of DSB mode checks the repeatability of the microwave switches. After the input signal passes through a 3 dB attenuator it is mixed with a local oscillator to produce a 25 MHz IF output. It is then amplified and sent to the noise figure meter. The microwave relays are checked 10 times for repeatability.

Results of all tests are compared with specified values to verify that the HP 8971B meets specifications.

Equipment

Noise Figure Meter	HP 8970B
Signal Generator	HP 8340B
Power Meter	HP 436A
Power Sensor	HP 8481A
Attenuator 3 dB	HP 8493A OPT. 003
Noise Source	HP 346B

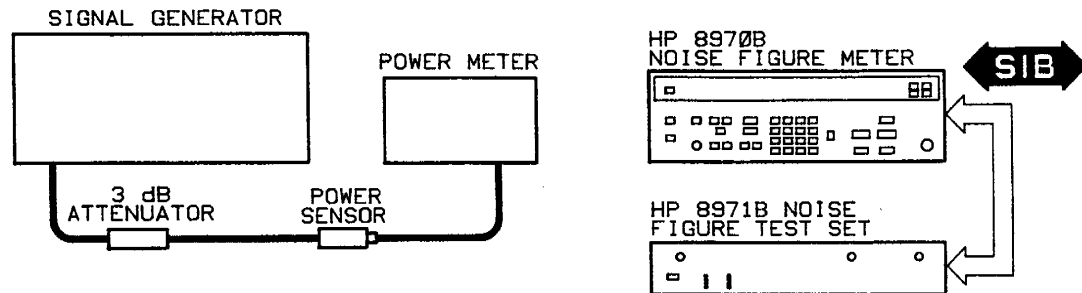

Figure 4-12. Gain Test Reference Setup SSB1

Procedure

SSB1 — 10 to 1600 MHz

1. Connect equipment as shown in Figure 4-12.
2. On the noise figure meter:
 - a. Press: **PRESET**
3. Enable communication with the HP 8971B on system interface bus.
 - a. Press: **4 5 . 1**
 - b. Press: **SPECIAL FUNCTION** (Ignore E42)
4. Enable mode 1.5 and set START FREQ to 1600 MHz.
 - a. Press: **1 . 5**
 - b. Press: **SPECIAL FUNCTION**
 - c. Press: **START FREQ**
 - d. Press: **1600**
 - e. Press: **ENTER**
5. Place the signal generator in local mode with output at 10 MHz.

6. Set the power level of the signal generator to +4 dBm.
7. Check the power level of the signal generator on the power meter. Adjust the signal generator for proper power, if necessary.
8. Set the signal generator to each of the frequencies in Table 4-11 and record the power level on the power meter under "Output Signal Generator". (frequencies are 10, 100, 300, 500, 700, 1000, 1300, and 1600 MHz).

Table 4-11. HP 8971B SSBI Noise Figure Gain

Frequency	Output Signal Generator	Output Test Set	Output Difference	Specified
10 MHz	_____	_____	_____	<=4 dB
100 MHz	_____	_____	_____	<=4 dB
300 MHz	_____	_____	_____	<=4 dB
500 MHz	_____	_____	_____	<=4 dB
700 MHz	_____	_____	_____	<=4 dB
1000 MHz	_____	_____	_____	<=4 dB
1300 MHz	_____	_____	_____	<=4 dB
1600 MHz	_____	_____	_____	<=4 dB

9. Disconnect the signal generator from the power meter. Connect the signal generator output (after the 3 dB attenuator) to the RF INPUT of the Noise Figure Test Set.
10. Connect the IF OUTPUT of the Noise Figure Test Set to the power meter. The test should now be configured as shown in Figure 4-13.
11. Set the signal generator to 10 MHz. Read the power meter and record the result in Table 4-11 under "Output Test Set".
12. Repeat step 11 for each of the frequencies in Table 4-11.
13. Subtract the power levels measured in the "Output Test Set" column from the power levels measured in the "Output Signal Generator" column and record in the "Output Difference" column.
14. If any item in the "Output Difference" column is greater than 4 dB, repeat measurements for that frequency and subtract again.

15. Perform this step ten times and record each reading in Table 4-12. Verify that all the difference between the largest and the smallest power meter readings is ≤ 0.2 dB

- a. Press: **STOP FREQ** (Ignore E-42)
- b. Press: **START FREQ**

Record the reading in Table 4-12.

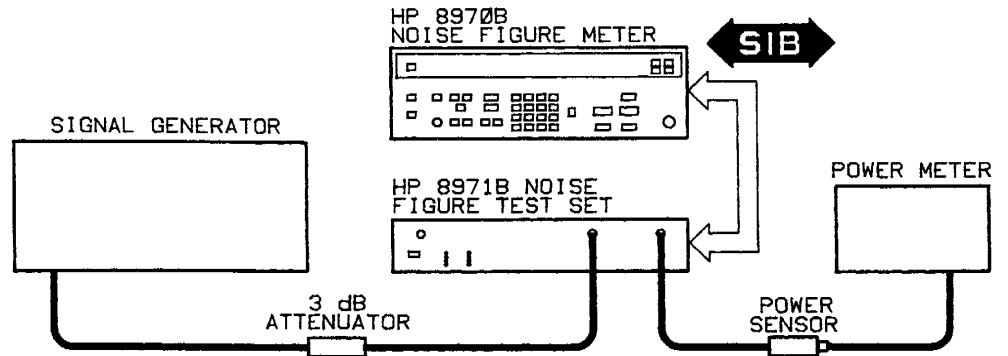

Figure 4-13. Gain Test Setup SSB1

Table 4-12. HP 8971B SSB1 Repeatability

Reading #	Reading
1	_____
2	_____
3	_____
4	_____
5	_____
6	_____
7	_____
8	_____
9	_____
10	_____
	Largest reading - smallest reading &= _____ ≤ 0.2 dB

Procedure (cont'd)

SSB2 — 1.6 to 2.4 GHz

1. Connect equipment as shown in Figure 4-14.
2. Warm up equipment for thirty minutes.

Insure correct ENR calibration tables for Noise Source used are entered in HP 8970B.
(See HP 8970B Operating Manual).

3. Press: **PRESET**
4. Enable communication with the HP 8971B in modes 1.5 to 1.9
 - a. Press: **4 5 . 0**
 - b. Press: **SPECIAL FUNCTION**
5. Enable Local Oscillator for fixed IF of 700 MHz
 - a. Press: **1 0 3**
 - b. Press: **SPECIAL FUNCTION**
 - c. Press: **3 0 0**
 - d. Press: **SPECIAL FUNCTION**
 - e. Press: **7 0 0**
 - f. Press: **ENTER**

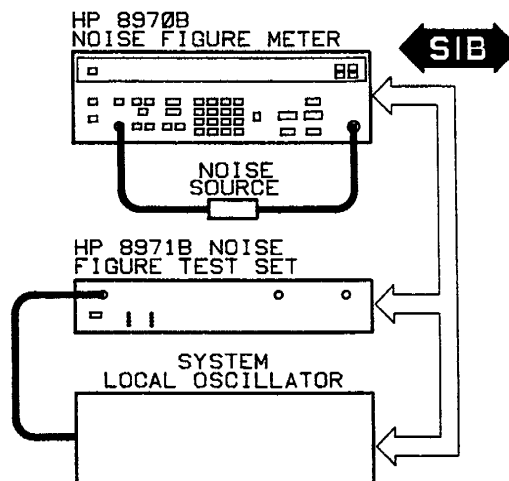

Figure 4-14. Noise Figure and Gain Calibration Test Setup SSB2/SSB3

6. Set for lower sideband measurement and select the correct LO program (SPECIAL FUNCTION 41.X)
 - a. Press: **2 0 1**
 - b. Press: **SPECIAL FUNCTION**
 - c. Press: **4 1 . 2** (For HP 8671B/8672A only)

- d. Press: **SPECIAL FUNCTION**
7. Increase Smoothing to 32.
 - a. Press: **INCREASE**
 - b. Press: **INCREASE**
 - c. Press: **INCREASE**
 - d. Press: **INCREASE**
 - e. Press: **INCREASE**
8. Calibrate the HP 8970B.
 - a. Press: **CALIBRATE**
 - b. Press: **CALIBRATE**

Wait for calibration to finish before proceeding.
9. Connect Noise Source to HP 8971B as shown in Figure 4-15. Make sure all other connections are made as shown — including HP-IB connections. Make sure the ENR table is set for the Noise Source (See the HP 8970B Operating Manual for instructions).
10. Enable mode 1.5 and set the Noise Figure Meter frequency to 2000 MHz. This puts the Noise Figure Test Set into SSB2.
 - a. Press: **1 . 5**
 - b. Press: **SPECIAL FUNCTION**
 - c. Press: **FREQUENCY**
 - d. Press: **2 0 0 0**
 - e. Press: **ENTER**
 - f. Press: **1 . 3**
 - g. Press: **SPECIAL FUNCTION**
11. To observe results, set up a 100 MHz increment and use the **▲** key.
 - a. Press: **START FREQ**
 - b. Press: **1 7 0 0**
 - c. Press: **ENTER**
 - d. Press: **FREQ INCR**
 - e. Press: **1 0 0**
 - f. Press: **ENTER**
 - g. Press: **NOISE FIGURE AND GAIN**
12. Record values of gain and noise figure in Table 4-13 using the **▲** key to step to each new frequency.

Table 4-13. HP 8971B SSB2 Noise Figure and Gain

Frequency	Gain >=0 dB	Noise Figure <=25 dB
1700 MHz	_____	_____
1800 MHz	_____	_____
1900 MHz	_____	_____
2000 MHz	_____	_____
2100 MHz	_____	_____
2200 MHz	_____	_____
2300 MHz	_____	_____
2400 MHz	_____	_____

13. On the noise figure meter: (Ignore E-23)

- a. Press: **1** **.** **3**
- b. Press: **SPECIAL FUNCTION**
- c. Press: **FREQUENCY**
- d. Press: **2** **4** **0** **0**
- e. Press: **ENTER**
- f. Press: **STORE** **1**
- g. Press: **1** **.** **5**
- h. Press: **SPECIAL FUNCTION**
- i. Press: **FREQUENCY**
- j. Press: **2** **4** **0** **0**
- k. Press: **ENTER**
- l. Press: **STORE** **2**
- m. Press: **FREQUENCY**
- n. Press: **3** **0** **0** **0**
- o. Press: **ENTER**
- p. Press: **STORE** **3**
- q. Press: **3** **5** **.** **3**
- r. Press: **SPECIAL FUNCTION**
- s. Press: **3** **5** **.** **2**
- t. Press: **SPECIAL FUNCTION**
- u. Press: **3**
- v. Press: **ENTER**

- w. Press: **2**
 - x. Press: **ENTER**
 - y. Press: **1**
 - z. Press: **ENTER**
 - aa. Press: **3 5 . 0**
 - bb. Press: **SPECIAL FUNCTION**
 - cc. Press: **FREQUENCY**
 - dd. Press: **2 4 0 0**
 - ee. Press: **ENTER**
14. Perform this step 10 times and record each noise figure and gain reading in Table 4-14. Verify that the difference between the largest and the smallest readings is ≤ 0.2 dB. Increase SMOOTHING to decrease jitter if necessary.
- a. Press: **SEQ** (wait for the HP 8971B to switch to SSB3)
 - b. Press: **SEQ**
 - c. Press: **SEQ**
 - d. Press: **NOISE FIGURE AND GAIN**
- Record the readings in Table 4-14.

Table 4-14. HP 8971B SSB2 Repeatability

Reading # (@ 2400 MHz)	Gain	Noise Figure
1		
2		
3		
4		
5		
6		
7		
8		
9		
10		
	Largest gain – smallest gain	Largest noise figure – smallest noise figure
	≤ 0.2 dB	≤ 0.2 dB

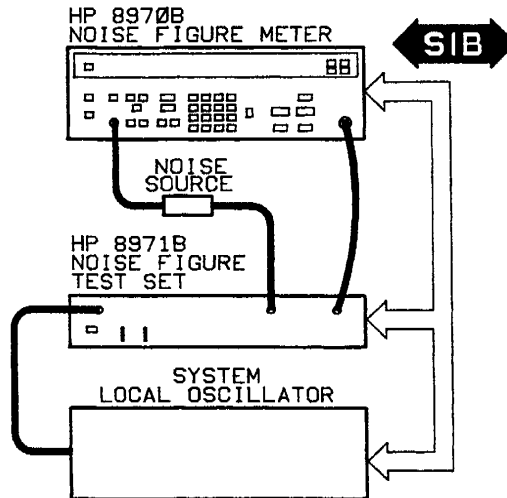

Figure 4-15. Noise Figure and Gain Test Setup SSB2/SSB3

Procedure (cont'd)

SSB3 — 2.4 to 18 GHz

1. Set up instruments as shown in Figure 4-15.
2. Turn on power to the instruments and allow a warm up of thirty minutes.
3. Preset the HP 8970B and select the correct LO program (SPECIAL FUNCTION 41.X)
 - a. Press: **PRESET**
 - b. Press: **4 1 . 2** (For HP 8671B/8672A only)
 - c. Press: **SPECIAL FUNCTION**

NOTE

The instrument responds slowly to some commands. Make sure that each time a key is pressed the instrument recognizes it and responds.

4. Enable communication with the HP 8971B in modes 1.5-1.9
 - a. Press: **4 5 . 0**
 - b. Press: **SPECIAL FUNCTION**
5. Enable mode 1.5
 - a. Press: **1 . 5**
 - b. Press: **SPECIAL FUNCTION** Ignore E28
6. Set Frequency points to calibrate the YIG filter
 - a. Press: **START FREQ**
 - b. Press: **2 5 0 0**
 - c. Press: **ENTER**

- d. Press: **STOP FREQ**
 - e. Press: **1 8 0 0 0**
 - f. Press: **ENTER**
 - g. Press: **STEP SIZE**
 - h. Press: **1 0 0 0**
 - i. Press: **ENTER**
7. Fine peak the YIG filter.
- a. Press: **3 6 . 3**
 - b. Press: **SPECIAL FUNCTION**
8. After "8971 CAL" disappears from the INSERTION GAIN and NOISE FIGURE displays, enable control of the YIG filter in mode 1.3 (this is accomplished by modifying a special RAM location) Ignore E23 if it appears.
- a. Press: **9 3 . 1**
 - b. Press: **SPECIAL FUNCTION**
 - c. Press: **6 5 4 5 8**
 - d. Press: **ENTER**
 - e. Press: **9 3 . 3**
 - f. Press: **SPECIAL FUNCTION**
- Write down the number in the HP 8970B display. _____
- g. Press: **9 3 . 1**
 - h. Press: **SPECIAL FUNCTION**
- Key in the number recorded above
- i. Press: **ENTER**
 - j. Press: **9 3 . 2**
 - k. Press: **SPECIAL FUNCTION**
 - l. Press: **1 6**
 - m. Press: **ENTER**
 - n. Press: **1 . 3**
 - o. Press: **SPECIAL FUNCTION**
9. Set measurement frequency parameters.
- a. Press: **FREQUENCY**
 - b. Press: **2 5 0 0**
 - c. Press: **ENTER**
 - d. Press: **FREQ INCR**
 - e. Press: **1 0 0 0**

- f. Press: **ENTER**
10. Fix Intermediate Frequency (IF) to 450 MHz.
 - a. Press: **3 . 0**
 - b. Press: **SPECIAL FUNCTION**
 - c. Press: **4 5 0**
 - d. Press: **ENTER**
11. Set smoothing to 32.
 - a. Press: **INCREASE**
 - b. Press: **INCREASE**
 - c. Press: **INCREASE**
 - d. Press: **INCREASE**
 - e. Press: **INCREASE**
12. Select Lower Sideband.
 - a. Press: **2 . 1**
 - b. Press: **SPECIAL FUNCTION**
13. Connect Noise Source to HP 8970B as shown in Figure 4-14, and calibrate.
 - a. Press: **CALIBRATE**
 - b. Press: **CALIBRATE**

Wait for calibration to finish before proceeding.
14. Connect system as shown in Figure 4-15.
15. Take measurement at 2500 MHz.
 - a. Press: **NOISE FIGURE AND GAIN**

Record results in Table 4-15.
16. To make the rest of the measurements:
 - a. Press: **▲**

Record Noise Figure and Gain for each frequency in Table 4-15.

Table 4-15. HP 8971B SSB3 Noise Figure and Gain

Frequency	Gain Specified	Gain Actual	Noise Figure Specified	Noise Figure Actual
2500 MHz	>= 2 dB	_____	<= 23 dB	_____
3500 MHz	>= 2 dB	_____	<= 23 dB	_____
4500 MHz	>= 2 dB	_____	<= 23 dB	_____
5500 MHz	>= 2 dB	_____	<= 23 dB	_____
6500 MHz	>= 2 dB	_____	<= 23 dB	_____
7500 MHz	>= 2 dB	_____	<= 23 dB	_____
8500 MHz	>= 2 dB	_____	<= 23 dB	_____
9500 MHz	>= 2 dB	_____	<= 23 dB	_____
10500 MHz	>= 2 dB	_____	<= 23 dB	_____
11500 MHz	>= 2 dB	_____	<= 23 dB	_____
12500 MHz	>= 1 dB	_____	<= 24 dB	_____
13500 MHz	>= 1 dB	_____	<= 24 dB	_____
14500 MHz	>= 1 dB	_____	<= 24 dB	_____
15500 MHz	>= -2 dB	_____	<= 28 dB	_____
16500 MHz	>= -2 dB	_____	<= 28 dB	_____
17500 MHz	>= -2 dB	_____	<= 28 dB	_____

17. Enable mode 1.5.

a. Press: **1 . 5**

b. Press: **SPECIAL FUNCTION**

18. Set Frequency points to calibrate the YIG filter.

a. Press: **START FREQ**

b. Press: **2 5 0 0**

c. Press: **ENTER**

d. Press: **STOP FREQ**

e. Press: **1 7 5 0 0**

f. Press: **ENTER**

g. Press: **STEP SIZE**

h. Press: **7 5 0 0**

i. Press: **ENTER**

19. Fine peak the YIG filter.

a. Press: **3 6 . 3**

b. Press: **SPECIAL FUNCTION**

Ignore E22 or E23. It will clear when we calibrate in step 21. Wait for "8971 CAL" to clear from the HP 8970B display before proceeding.

20. Enable measurement mode 1.3.

a. Press: **1** **.** **3**

b. Press: **SPECIAL FUNCTION**

21. Connect the noise source to the HP 8970B as shown in Figure 4-14 and calibrate.

a. Press: **CALIBRATE**

b. Press: **CALIBRATE**

Wait for the calibration to finish before proceeding.

22. Connect the system as shown in Figure 4-15.

23. Set the noise figure meter to test repeatability

a. Press: **FREQUENCY**

b. Press: **2** **5** **0** **0**

c. Press: **ENTER**

d. Press: **STORE**

e. Press: **1**

f. Press: **FREQUENCY**

g. Press: **1** **0** **0** **0** **0**

h. Press: **ENTER**

i. Press: **STORE**

j. Press: **2**

k. Press: **FREQUENCY**

l. Press: **1** **7** **5** **0** **0**

m. Press: **ENTER**

n. Press: **STORE**

o. Press: **3**

p. Press: **1** **.** **5**

q. Press: **SPECIAL FUNCTION**

r. Press: **FREQUENCY**

s. Press: **1** **7** **5** **0** **0**

t. Press: **ENTER**

u. Press: **STORE**

v. Press: **4**

Ignore E23

- w. Press: **FREQUENCY**
- x. Press: **2 0 0 0**
- y. Press: **ENTER**
- z. Press: **STORE**
- aa. Press: **5**
- bb. Press: **START FREQ**
- cc. Press: **3 5 . 3**
- dd. Press: **SPECIAL FUNCTION**
- ee. Press: **3 5 . 2**
- ff. Press: **SPECIAL FUNCTION**
- gg. Press: **1**
- hh. Press: **ENTER**
- ii. Press: **2**
- jj. Press: **ENTER**
- kk. Press: **3**
- ll. Press: **ENTER**
- mm. Press: **3 5 . 0**
- nn. Press: **SPECIAL FUNCTION**

24. To test repeatability due to YIG tuning, perform this step 10 times:

- a. Press: **SEQ**
Press: **NOISE FIGURE AND GAIN**
Record the gain and noise figure readings in Table 4-16.
- b. Press: **SEQ**
Press: **NOISE FIGURE AND GAIN**
Record the gain and noise figure readings in Table 4-16.
- c. Press: **SEQ**
Press: **NOISE FIGURE AND GAIN**

Record the gain and noise figure readings at 17500 MHz in Table 4-16. Continue with step 24a until 10 readings have been taken at each frequency in Table 4-16.

The value of the difference between the highest and lowest value in each column below must be ≤ 0.2 dB.

Table 4-16. HP 8971B SSB3 Repeatability (YIG Tuning)

2500 MHz	2500 MHz	10000 MHz	10000 MHz	17500 MHz	17500 MHz
Gain	Noise Figure	Gain	Noise Figure	Gain	Noise Figure
1 _____	1 _____	1 _____	1 _____	1 _____	1 _____
2 _____	2 _____	2 _____	2 _____	2 _____	2 _____
3 _____	3 _____	3 _____	3 _____	3 _____	3 _____
4 _____	4 _____	4 _____	4 _____	4 _____	4 _____
5 _____	5 _____	5 _____	5 _____	5 _____	5 _____
6 _____	6 _____	6 _____	6 _____	6 _____	6 _____
7 _____	7 _____	7 _____	7 _____	7 _____	7 _____
8 _____	8 _____	8 _____	8 _____	8 _____	8 _____
9 _____	9 _____	9 _____	9 _____	9 _____	9 _____
10 _____	10 _____	10 _____	10 _____	10 _____	10 _____
Largest gain – smallest gain	Largest NF – smallest NF	Largest gain – smallest gain	Largest NF – smallest NF	Largest gain – smallest gain	Largest NF – smallest NF
<= 0.2 dB	<= 0.2 dB	<= 0.2 dB	<= 0.2 dB	<= 0.2 dB	<= 0.2 dB

25. Set the HP 8970B to test the repeatability of the microwave relays.

- a. Press: **3** **5** **.** **3**
- b. Press: **SPECIAL FUNCTION**
- c. Press: **3** **5** **.** **2**
- d. Press: **SPECIAL FUNCTION**
- e. Press: **5**
- f. Press: **ENTER**
- g. Press: **4**
- h. Press: **ENTER**
- i. Press: **3**
- j. Press: **ENTER**
- k. Press: **3** **5** **.** **0**
- l. Press: **SPECIAL FUNCTION**

26. To test the repeatability of the microwave relays, perform this step 10 times and record the results in Table 4-17.

- a. Press: **SEQ** (Wait for HP 8971B to switch bands)
- b. Press: **SEQ**
- c. Press: **SEQ**

d. Press: **NOISE FIGURE AND GAIN**

Record the gain and noise figure readings in Table 4-17.

Table 4-17. HP 8971B SSB3 Repeatability (Microwave Relays)

Reading # (@ 17500 MHz)	Gain	Noise Figure
1	_____	_____
2	_____	_____
3	_____	_____
4	_____	_____
5	_____	_____
6	_____	_____
7	_____	_____
8	_____	_____
9	_____	_____
10	_____	_____
	Largest gain – smallest gain	Largest noise figure – smallest noise figure
	<= 0.2 dB	<= 0.2 dB

**Procedure
(cont'd)**

DSB – 2.4 to 18 GHz (Repeatability)

1. Set up equipment as shown in Figure 4-13.
2. Turn on power to the instruments and warm them up for thirty minutes.
3. Preset the HP 8970B and select the correct LO program (SPECIAL FUNCTION 41.X)
 - a. Press: **PRESET**
 - b. Press: **4 1 . 2** (For HP 8671B/8672A only)
 - c. Press: **SPECIAL FUNCTION**
4. Enable control of the HP 8971B.
 - a. Press: **4 5 . 0**
 - b. Press: **SPECIAL FUNCTION**
 - c. Press: **1 . 3**
 - d. Press: **SPECIAL FUNCTION**
5. Enable DSB mode.
 - a. Press: **2 . 0**
 - b. Press: **SPECIAL FUNCTION**

6. Set the Local Oscillator for fixed IF of 25 MHz.
 - a. Press: **3** **.** **0**
 - b. Press: **SPECIAL FUNCTION**
 - c. Press: **2** **5**
 - d. Press: **ENTER**
7. Set smoothing to 32.
 - a. Press: **INCREASE**
 - b. Press: **INCREASE**
 - c. Press: **INCREASE**
 - d. Press: **INCREASE**
 - e. Press: **INCREASE**
8. Make sure the Noise Source is connected to the HP 8970B as shown in Figure 4-13, and calibrate.
 - a. Press: **CALIBRATE**
 - b. Press: **CALIBRATE** Wait for the calibration to finish before proceeding.
9. Connect up system as shown in Figure 4-14.
 - a. Press: **1** **.** **5**
 - b. Press: **SPECIAL FUNCTION**
 - c. Press: **1** **7** **.** **1**
 - d. Press: **SPECIAL FUNCTION**
 - e. Press: **FREQUENCY**
 - f. Press: **2** **5** **0** **0**
 - g. Press: **ENTER**
 - h. Press: **1** **.** **3**
 - i. Press: **SPECIAL FUNCTION**
10. Set the HP 8970B for measurements.
 - a. Press: **NOISE FIGURE AND GAIN**
11. Set up the noise figure meter to test repeatability.
 - a. Press: **1** **.** **5** **SPECIAL FUNCTION**
 - b. Press: **FREQUENCY**
 - c. Press: **1** **0**
 - d. Press: **ENTER**
 - e. Press: **STORE**
 - f. Press: **1**
 - g. Press: **FREQUENCY**

- h. Press: **1 8 0 0 0**
- i. Press: **ENTER**
Ignore E23.
- j. Press: **STORE**
- k. Press: **2**
- l. Press: **STORE**
- m. Press: **4**
Ignore E38, if necessary.
- n. Press: **1 . 3**
- o. Press: **SPECIAL FUNCTION**
- p. Press: **FREQUENCY**
- q. Press: **1 8 0 0 0**
- r. Press: **ENTER**
- s. Press: **2 . 0**
- t. Press: **SPECIAL FUNCTION**
- u. Press: **STORE**
- v. Press: **3**
- w. Press: **3 5 . 3**
- x. Press: **SPECIAL FUNCTION**
- y. Press: **3 5 . 2**
- z. Press: **SPECIAL FUNCTION**
- aa. Press: **1**
- bb. Press: **ENTER**
- cc. Press: **2**
- dd. Press: **ENTER**
- ee. Press: **3**
- ff. Press: **ENTER**
- gg. Press: **4**
- hh. Press: **ENTER**
- ii. Press: **3 5 . 0**
- jj. Press: **SPECIAL FUNCTION**
12. Perform this step 10 times and record the gain and noise figure readings in Table 4-18.
- a. Press: **SEQ** (Wait for the HP 8971B to switch bands.)
- b. Press: **SEQ**

c. Press: **SEQ**

d. Press: **NOISE FIGURE AND GAIN**

Record the gain and noise figure readings in Table 4-18. Verify that the difference between the largest and the smallest gain (and noise figure) is less than or equal to 0.2 dB.

Table 4-18. HP 8971B DSB Repeatability (Microwave Relays)

Reading # (@ 18000 MHz)	Gain	Noise Figure
1		
2		
3		
4		
5		
6		
7		
8		
9		
10		
	Largest gain – smallest gain	Largest noise figure – smallest noise figure
	≤ 0.2 dB	≤ 0.2 dB

Sales and Service Offices

If you need technical assistance with a Hewlett-Packard test and measurement product or application please contact the Hewlett-Packard office or distributor in your country.

Asia Pacific:

Hong Kong: (852) 2599 7889

India: (91-11) 647 2311

Japan:

Hewlett-Packard Japan Ltd.
Measurement Assistance Center
9-1, Takakura-Cho, Hachioji-Shi,
Tokyo 192, Japan
Tel: (81-426) 56-7832
Fax: (81-426) 56-7840

Korea: (82-2) 769 0800

Malaysia: (60-3) 291 0213

Philippines: (63-2) 894 1451

PRC: (86-10) 6505 0149

Singapore: (1800) 292 8100

Taiwan: (886-3) 492 9666

Thailand: (66-2) 661 3900

For countries in Asia Pacific not listed contact:

Hewlett-Packard Asia Pacific Ltd.
17-21/F Shell Tower, Times Square,
1 Matheson Street, Causeway Bay,
Hong Kong
tel: (852) 2599 7070
fax: (852) 2506 9285

POST-SALES / SUPPORT ADDRESS LIST

If you need technical assistance with a Hewlett-Packard test and measurement product or application please contact the Hewlett-Packard office or distributor in your country.

Asia Pacific:

Hong Kong:

(852) 2599 7889

India:

(91-11) 682-6000

Japan:

Hewlett-Packard Japan Ltd.
Measurement Assistance Center
9-1, Takakura-Cho, Hachioji-Shi,
Tokyo 192-8510, Japan
Tel: (81) 426-56-7832
Fax: (81) 426-56-7840

Korea:

(82-2) 769 0800

Malaysia:

(60-3) 291 0213

Philippines:

(63-2) 894 1451

PRC:

(86-10) 6505 0149

Singapore:

(1800) 292 8100

Taiwan:

(886-3) 492 9666

Thailand:

(66-2) 661 3900

For countries in Asia Pacific not listed, contact:

Hewlett-Packard Asia Pacific Ltd
17-21/F Shell Tower, Times Square,
1 Matheson Street
Causeway Bay
Hong Kong
Tel: (852) 2599 7777
Fax: (852) 2506 9285

Australia/New Zealand:

Hewlett-Packard Australia Ltd.
31-41 Joseph Street
Blackburn, Victoria 3130
Australia
1 800 629 485

Canada:

Hewlett-Packard Canada Ltd.
5150 Spectrum Way
Mississauga, Ontario
L4W 5G1
(905) 206 4725

Europe, Africa and Middle East:

Austria:

(0)1 25000-0

Belgium and Luxembourg:

(02) 778 3417

Baltic Countries

(358) 08872 2100

Czech Republic:

420-2-4743111

Denmark:

45 99 10 00

Finland:

(90) 88 721

France:

(0)1 69.82.60.60

Germany:

(0180) 532 62-33

Greece:

30-1-7264045

Hungary:

36-1-4618219

Ireland:

(01) 284 4633

Israel:

972-3-5380333

Italy:

02 - 92 122 241

Netherlands:

(020) 547 6669

Norway:

(22) 73 57 50

Poland:

48-22-6087700

Portugal:

(11) 482 85 00

Russia:

(7/095) 928 6885

Fax: (7/095) 916 9844

South Africa:

27-11-8061000

Spain:

(34) 1 631 1323

Sweden:

(08) 444 22 77

Switzerland:

(01) 735 7111

Turkey:

90-212-2245925

United Kingdom:

(01344) 366 666

For countries in Europe/Middle East and Africa not listed, contact:

Hewlett-Packard
International Sales Europe
Geneva, Switzerland
Tel: +41-22-780-4111
Fax: +41-22-780-4770

Latin America:

Hewlett-Packard
Latin American Region Headquarters
5200 Blue Lagoon Drive
9th Floor
Miami, Florida 33126
U.S.A.
Tel: (305) 267-4245
(305) 267-4220
Fax: (305) 267-4288

United States:

Hewlett-Packard Company
Test and Measurement Organization
5301 Stevens Creek Blvd.
Bldg. 51L-SC
Santa Clara, CA 95052-8059
1 800 452 4844