

89440A

Installation and Verification Guide

Manufacturing Part Number: 89440-90056

Printed in USA

November 1996

© Copyright 1992-1996, 2005 Agilent Technologies



Agilent Technologies

Notice

Hewlett-Packard to Agilent Technologies Transition

This manual may contain references to HP or Hewlett-Packard. Please note that Hewlett-Packard's former test and measurement, semiconductor products and chemical analysis businesses are now part of Agilent Technologies. To reduce potential confusion, the only change to product numbers and names has been in the company name prefix: where a product name/number was HP XXXX the current name/number is now Agilent XXXX. For example, model number HP8648 is now model number Agilent 8648.

Contacting Agilent Sales and Service Offices

The sales and service contact information in this manual may be out of date. The latest service and contact information for your location can be found on the Web at:

<http://www.agilent.com/find/assist>

If you do not have access to the Internet, contact your field engineer or the nearest sales and service office listed below. In any correspondence or telephone conversation, refer to your instrument by its model number and full serial number.

United States

(tel) 1 800 452 4844
(fax) 1 800 829 4433

Canada

(tel) +1 877 894 4414
(fax) +1 888 900 8921

Europe

(tel) (31 20) 547 2323
(fax) (31 20) 547 2390

Latin America

(tel) (305) 269 7500
(fax) (305) 269 7599

Japan

(tel) (81) 426 56 7832
(fax) (81) 426 56 7840

Australia

(tel) 1 800 629 485
(fax) (61 3) 9210 5947

New Zealand

(tel) 0 800 738 378
(fax) 64 4 495 8950

Asia Pacific

(tel) (852) 3197 7777
(fax) (852) 2506 9284



Agilent Technologies

Printed in USA July 2004

The HP 89440A at a Glance

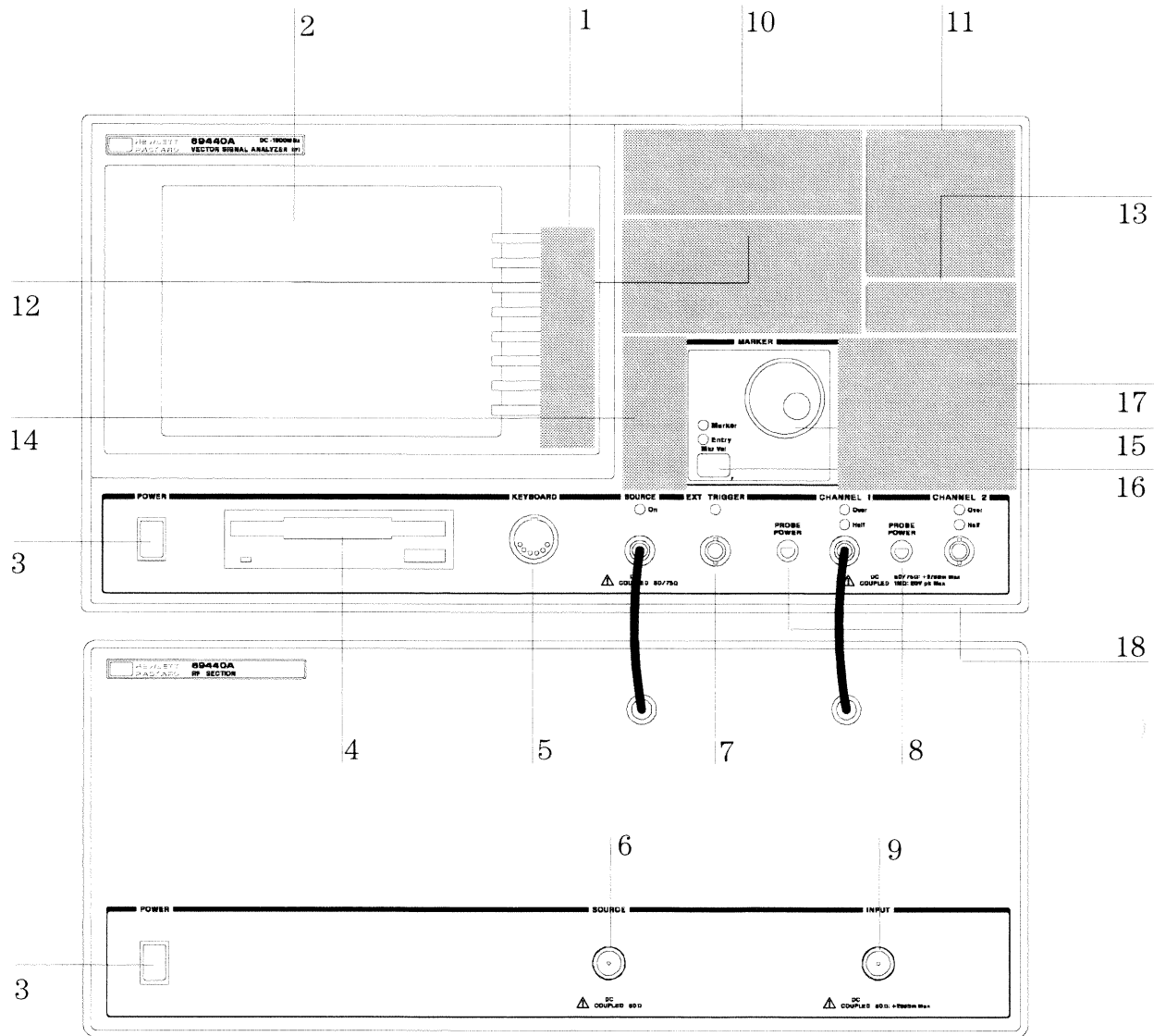

HP 89440A Front Panel

1-A softkey's function changes as different menus are displayed. Its current function is determined by the video label to its left, on the analyzer's screen.

2-The analyzer's screen is divided into two main areas. The menu area, a narrow column at the screen's right edge, displays softkey labels. The data area, the remaining portion of the screen, displays traces and other data.

3-The POWER switch turns the analyzer on and off.

4-Use a 3.5-inch flexible disk (DS,HD) in this disk drive to save your work.

5-The KEYBOARD connector allows you to attach an optional keyboard to the analyzer. The keyboard is most useful for writing and editing HP Instrument BASIC programs.

6- The SOURCE connector routes the analyzer's source output to your DUT. If option AY8 (internal RF source) is installed, the connector is a type-N. If option AY8 is not installed, the connector is a BNC. Output impedance is 50 ohms or 75 ohms with option 1D7 (minimum loss pads).

7-The EXT TRIGGER connector lets you provide an external trigger for the analyzer.

8-The PROBE POWER connectors provides power for various HP active probes.

9-The INPUT connector routes your test signal or DUT output to the analyzer's receiver. Input impedance is 50 ohms or 75 ohms with option 1D7 (minimum loss pads).

10-Use the DISPLAY hardkeys and their menus to select and manipulate trace data and to select display options for that data.

11-Use the SYSTEM hardkeys and their menus to control various system functions (online help, plotting, presetting, and so on).

12-Use the MEASUREMENT hardkeys and their menus to control the analyzer's receiver and source, and to specify other measurement parameters.

13-The REMOTE OPERATION hardkey and LED indicators allow you to set up and monitor the activity of remote devices.

14-Use the MARKER hardkeys and their menus to control marker positioning and marker functions.

15-The knob's primary purpose is to move a marker along the trace. But you can also use it to change values during numeric entry, move a cursor during text entry, or select a hypertext link in help topics.

16-Use the Marker/Entry key to determine the knob's function. With the Marker indicator illuminated, the knob moves a marker along the trace. With the Entry indicator illuminated, the knob changes numeric entry values.

17-Use the ENTRY hardkeys to change the value of numeric parameters or to enter numeric characters in text strings.

18-The optional CHANNEL 2 input connector routes your test signal or DUT output to the analyzer's receiver. Input impedance is selectable: 50 ohms, 75 ohms, or 1 megohm. For ease of upgrading, the CHANNEL 2 BNC connector is installed even if option AY7 (second input channel) is not installed.

For more details on the HP 89440A front panel, display the online help topic "Front Panel."

This page left intentionally blank.

Options and Accessories

To determine if an option is installed, press [**System Utility**] [option setup]. Installed options are also listed on the analyzer's rear panel.

To order an option to upgrade your HP 89440A, order HP 89440U followed by the option number.

Option Description		HP 89440U Option
Add Internal RF Source		AY8
Add High Precision Frequency Reference		AYC
Add Vector Modulation Analysis		AYA
Add Waterfall and Spectrogram		AYB
Add Digital Video Modulation Analysis and Adaptive Equalization		AYH
Add Adaptive Equalization to option AYA		AYJ
Add Second 10 MHz Input Channel		AY7
Extend Time Capture to 1 megasample		AY9
Add 4 megabyte Extended RAM and Additional I/O		UFG
Add Advanced LAN Support		UG7
Add HP Instrument BASIC		1C2
Add 50 - 75 Ohm Minimum Loss Pads		1D7
Add PC-Style Keyboard and Cable	U.S. version	1F0
Add PC-Style Keyboard and Cable	German version	1F1
Add PC-Style Keyboard and Cable	Spanish version	1F2
Add PC-Style Keyboard and Cable	French version	1F3
Add PC-Style Keyboard and Cable	U.K. version	1F4
Add PC-Style Keyboard and Cable	Italian version	1F5
Add PC-Style Keyboard and Cable	Swedish version	1F6
Add Front Handle Kit		AX3
Add Rack Flange Kit		AX4
Add Flange and Handle Kit		AX5
Add Extra Manual Set		OB1
Add Extra Instrument BASIC Manuals		OBU
Add Service Manual		OB3

The accessories listed in the following table are supplied with the HP 89440A.

Supplied Accessories

Line Power Cable (see page 1-4)

Rear Panel Lock Foot Kit (HP 5062-3999)

BNC Cable - 12 inch (HP 8120-1838)

2 BNC Cables - 8.5 inch (HP 8120-2682)

Coax BNC(m)-to-coax BNC(m) Connector (HP 1250-1499, deleted with option AY4)

Type N-to-BNC Adapter (HP 1250-0780, 2 with option AY8)

Serial Interface Interconnect Cable (HP 8120-6230)

Interconnect Cable EMI Suppressor (HP 9170-1521)

Standard Data Format Utilities (HP 5061-8054)

HP 89440A/HP 89441A Operator's Guide

HP 89440A/HP 89441A Getting Started Guide

HP 89440A Installation and Verification Guide

HP 89400 Series HP-IB Command Reference

HP 89400 Series HP-IB Quick Reference

HP 89400 Series Documentation Roadmap

The accessories listed in the following table are available for the HP 89440A.

Available Accessories	Part Number
HP 89411A 21.4 MHz Down Converter	HP 89411A
<i>Spectrum and Network Measurements</i>	HP 5960-5718
Box of ten 3.5-inch double-sided, double-density disks	HP 92192A
Active Probe	HP 41800A
Active Probe	HP 54701A
Active Divider Probe	HP 1124A
Resistor Divider Probe	HP 10020A
Differential Probe (requires HP 1142A)	HP 1141A
Probe Control and Power Module	HP 1142A
50 Ohm RF Bridge	HP 86205A
Switch/Control Unit	HP 3488A
High-Performance Switch/Control Unit	HP 3235A
HP-IB Cable - 1 meter	HP 10833A
HP-IB Cable - 2 meter	HP 10833B
HP-IB Cable - 4 meter	HP 10833C
HP-IB Cable - 0.5 meter	HP 10833D
HP ThinkJet Printer	HP 2225A
HP QuietJet Plus Printer	HP 2227B
HP Jet Paper	HP 92261N
HP ColorPro 8-Pen Plotter, option 002	HP 7440A
6-Pen Graphic Plotter, option 002	HP 7475A
8-Pen Graphic Plotter, option 005	HP 7550B

This page left intentionally blank.

Notation Conventions

Before you use this book, it is important to understand the types of keys on the front panel of the analyzer and how they are denoted in this book.

Hardkeys Hardkeys are front-panel buttons whose functions are always the same. Hardkeys have a label printed directly on the key. In this book, they are printed like this: **[Hardkey]**.

Softkeys Softkeys are keys whose functions change with the analyzer's current menu selection. A softkey's function is indicated by a video label to the left of the key (at the edge of the analyzer's screen). In this book, softkeys are printed like this: [softkey].

Toggle Softkeys Some softkeys toggle through multiple settings for a parameter. Toggle softkeys have a word highlighted (of a different color) in their label. Repeated presses of a toggle softkey changes which word is highlighted with each press of the softkey. In this book, toggle softkey presses are shown with the requested toggle state in bold type as follows:

"Press [key name **on**]" means "press the softkey [key name] until the selection on is active."

Shift Functions In addition to their normal labels, keys with blue lettering also have a shift function. This is similar to shift keys on a pocket calculator or the shift function on a typewriter or computer keyboard. Using a shift function is a two-step process. First, press the blue **[Shift]** key (at this point, the message "shift" appears on the display). Then press the key with the shift function you want to enable. Shift function are printed as two key presses, like this:

[Shift] [Shift Function]

Numeric Entries Numeric values may be entered by using the numeric keys in the lower right hand ENTRY area of the analyzer front panel. In this book, values which are to be entered from these keys are indicated only as numerals in the text, like this:
Press 50, [enter]

Ghosted Softkeys A softkey label may be shown in the menu when it is inactive. This occurs when a softkey function is not appropriate for a particular measurement or not available with the current analyzer configuration. To show that a softkey function is not available, the analyzer "ghosts" the inactive softkey label. A ghosted softkey appears less bright than a normal softkey. Settings/values may be changed while they are inactive. If this occurs, the new settings are effective when the configuration changes such that the softkey function becomes active.

This page left intentionally blank.

In This Book

This guide provides instructions for installing and verifying the performance of the HP 89440A DC-1800 MHz Vector Signal Analyzer.

Chapter 1, “Preparing the Analyzer for Use,” provides step-by-step instructions for getting the analyzer ready to use and instructions on cleaning the screen, storing, and transporting.

Chapter 2, “Verifying Specifications,” provides step-by-step instructions for installing and running the semiautomated performance test software. This chapter also provides illustrations that show the equipment set up for each test and a copy of the test records.

This page left intentionally blank.

Table of Contents

1 Preparing the Analyzer for Use

- To do the incoming inspection 1-5
- To connect the sections 1-7
- To install the analyzer 1-9
- To change the IF section's line-voltage switch 1-10
- To change the RF section's line-voltage switch 1-11
- To change the IF section's fuse 1-12
- To change the RF section's fuse 1-13
- To connect the analyzer to a LAN 1-14
- To connect the analyzer to a serial device 1-15
- To connect the analyzer to a parallel device 1-15
- To connect the analyzer to an HP-IB device 1-16
- To connect the analyzer to an external monitor 1-17
- To connect the optional keyboard 1-18
- To connect the optional minimum loss pad 1-19
- To clean the screen 1-20
- To store the analyzer 1-20
- To transport the analyzer 1-21
- If the IF section will not power up 1-22
- If the RF section will not power up 1-23
- If the analyzer's stop frequency is 10 MHz 1-24

2 Verifying Specifications

- To load the program 2-11
- To run the program in semiautomated mode 2-13
- To run the program without a printer 2-15
- To run the program in manual mode 2-17
- To set up the self test 2-18
- To set up the amplitude accuracy test 2-19
- To set up the amplitude linearity test 2-25
- To set up the amp_phase match test 2-27
- To set up the intermodulation distortion test 2-29

To set up the input coupling test 2-32
To set up the input trigger test 2-34
To set up the external trigger test 2-36
To set up the external arm test 2-37
To set up the harmonic distortion test 2-38
To set up the input capacitance test 2-41
To set up the input resistance test 2-44
To set up the dc offset test 2-46
To set up the spurious signals test 2-47
To set up the noise test 2-48
To set up the cross talk test 2-49
To set up the anti-alias filter test 2-51
To set up the source amplitude accuracy test 2-53
To set up the input rtn loss test 2-55
To set up the source rtn loss test 2-59
To set up the source distortion test 2-62
To set up the RF-amplitude accuracy test 2-63
To set up the phase noise test 2-64
To set up the LO spurs test 2-65
To set up the RF-spurious signals test 2-66
To set up the RF-harmonic distortion test 2-67
To set up the frequency accuracy test 2-69
To set up the RF-noise test 2-70
To set up the RF-source amplitude accuracy test 2-71
To set up the RF-source IF-flatness test 2-72
To set up the RF-source distortion test 2-73
To set up the RF-source noise test 2-74
Measurement Uncertainty 2-80
Performance Test Record 1 through 18
Operation Verification Test Record 1 through 11

Index

Hp 89400-Series Documentation Roadmap

Declaration of Conformity

Need Assistance?

About this edition

1

Preparing the Analyzer for Use

Preparing the Analyzer for Use

This chapter contains instructions for inspecting and installing the HP 89440A DC-1800 MHz Vector Signal Analyzer. This chapter also includes instructions for cleaning the screen, transporting and storing the analyzer.

Power Requirements

The analyzer can operate from a single-phase ac power source supplying voltages as shown in the table. With all options installed, the total power consumption of both sections is less than 1025 VA.

AC Line Voltage	
Range	Frequency
90-140 Vrms	47-63 Hz
198-264 Vrms	47-63 Hz

The line-voltage selector switches are set at the factory to match the most commonly used line voltage in the country of destination; the appropriate fuses are also installed. To check or change either the line-voltage selector switch or the fuse, see the appropriate sections later in this chapter.

Warning

Only a qualified service person, aware of the hazards involved, should measure the line voltage.

Caution

Before applying ac line power to the analyzer, ensure the line-voltage selector switches are set for the proper line voltage and the correct line fuses are installed in the fuse holders.

Power Cable and Grounding Requirements

On the HP-IB connector, pin 12 and pins 18 through 24 are tied to chassis ground and the HP-IB cable shield. The instrument frame, chassis, covers, and all exposed metal surfaces including the connectors' outer shell are connected to chassis ground. However, if channel 2 in the IF section is not installed, the channel 2 BNC connector's outer shell is not connected to chassis ground.

Warning

DO NOT interrupt the protective earth ground or “float” the HP 89440A DC-1800 MHz Vector Signal Analyzer. This action could expose the operator to potentially hazardous voltages.

The analyzer is equipped with two three-conductor power cords which ground the analyzer when plugged into appropriate receptacles. The type of power cable plug shipped with each analyzer depends on the country of destination. The following figure shows available power cables and plug configurations.

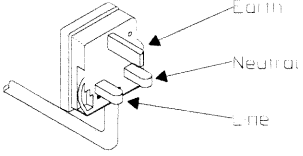
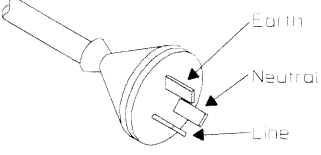
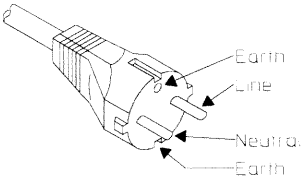
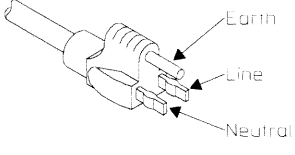
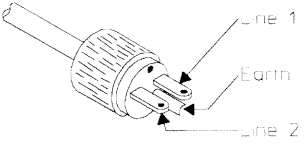
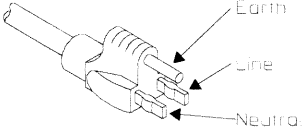
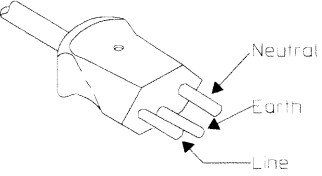
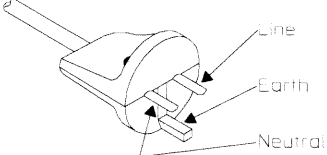
<p>United Kingdom Option 900</p>  <p>PLUG*: BS 1363A CABLE*: HP 8120-1351</p> <p>220V-5A OPERATION</p>	<p>Australia/New Zealand Option 901</p>  <p>PLUG*: NZSS 198/AS C112 CABLE*: HP 8120-1369</p> <p>220V-6A OPERATION</p>
<p>Continental Europe Option 902</p>  <p>PLUG*: CEE7-V11 CABLE*: HP 8120-1689</p> <p>220V-6A OPERATION</p>	<p>North America Option 903</p>  <p>PLUG*: NEMA 5-15P CABLE*: HP 8120-1378</p> <p>125V-10A** OPERATION</p>
<p>North America Option 904</p>  <p>PLUG*: NEMA 6-15P CABLE*: HP 8120-0698</p> <p>250V-6A** OPERATION</p>	<p>Japan Option 918</p>  <p>PLUG*: MITI 41-9692 CABLE*: HP 8120-4753</p> <p>125V-12A OPERATION</p>
<p>Switzerland Option 906</p>  <p>PLUG*: SEV 1011.1959-24507 TYPE 12 CABLE*: HP 8120-2104</p> <p>220V-6A OPERATION</p>	<p>Denmark Option 912</p>  <p>PLUG*: DFCR 107 CABLE*: HP 8120-2956</p> <p>220V-6A OPERATION</p>

*The number shown for the plug is the industry identifier for the plug only, the number shown for the cable is an HP part number for a complete cable including the plug.

**UL listed for use in the United States of America.

Warning

The power cable plug must be inserted into an outlet provided with a protective earth terminal. Defeating the protection of the grounded analyzer cabinet can subject the operator to lethal voltages.

To do the incoming inspection

The HP 89440A DC-1800 MHz Vector Signal Analyzer was carefully inspected both mechanically and electrically before shipment. It should be free of marks or scratches, and it should meet its published specifications upon receipt.

- 1 Inspect the analyzer for physical damage incurred in transit. If the analyzer was damaged in transit, do the following:**
 - Save all packing materials.
 - File a claim with the carrier.
 - Call your Hewlett-Packard sales and service office.

Warning

If the analyzer is mechanically damaged, the integrity of the protective earth ground may be interrupted. Do not connect the analyzer to power if it is damaged.

- 2 Check that the line-voltage selector switches are set for the local line voltage.**

The line-voltage selector switches are set at the factory to match the most commonly used line voltage in the country of destination. To check or change the line-voltage selector switches, see “To change the IF section’s line-voltage switch” and “To change the RF section’s line-voltage switch.”

- 3 Check that the correct line fuses are installed in the fuse holders.**

The fuses are installed at the factory for the most commonly used line voltage in the country of destination. The analyzer’s IF section requires an 8 amp, 250 volt, normal blow fuse for 115 V operation and a 4 amp, 250 volt, normal blow fuse for 230 volt operation. The analyzer’s RF section requires a 3 amp, 250 volt, normal blow fuse for 100/120 volt operation and a 1.5 amp, 250 volt, slow blow fuse for 220/240 volt operation. For instructions on removing the fuse or fuse part numbers, see “To change the IF section’s fuse” and “To change the RF section’s fuse.”

- 4 Connect the IF section to the RF section.**

For instructions on connecting the sections, see “To connect the sections.”

- 5 Using the supplied power cords, plug the analyzer’s IF section and RF section into appropriate receptacles.**

The analyzer is shipped with two three-conductor power cords that ground the analyzer when plugged into appropriate receptacles. The type of power cable plug shipped with each analyzer depends on the country of destination.

6 Set the RF section's rear panel and front panel power switches to on.

Press the “ I ” symbol end of the rocker-switches located on the lower right of the rear panel and on the lower left of the front panel. The RF section provides standby power for the high precision frequency reference. The rear-panel power switch interrupts all power including standby power when you press the “ O ” symbol end of the switch. The front-panel power switch interrupts all power except standby power when you press the “ ⓪ ” symbol end of the switch.

7 Set the IF section's power switch to on.

Press the “ I ” symbol end of the rocker-switch located on the lower left of the front panel. The analyzer requires about 30 seconds to complete its power-on routine.

8 Test the electrical performance of the analyzer using the operation verification or the performance tests in chapter 2, “Verifying Specifications.”

The operation verification tests verify the basic operating integrity of the analyzer; these tests take about 2.5 hours to complete and are a subset of the performance tests. The performance tests verify that the analyzer meets all the performance specifications; these tests take about 5 hours to complete.

To connect the sections

Do NOT use the IF section's EXT REF OUT connector or optional OVEN REF OUT connector as an external reference output.

1 Attach the IF section to the RF section.

If the hardware is not installed, follow the instructions supplied with the Rear Panel Lock Foot Kit. If the hardware is already installed, slide the IF section on top of the RF section making sure the front lock-links engage the IF section's frame. Screw the rear lock feet together.

2 Connect the RF section's SERIAL 2 port to the IF section's SERIAL 2 port using the supplied serial interface interconnect cable. Make sure the end of the cable with the EMI suppressor is connected to the IF section.

3 Connect the RF section's OVEN REF OUT connector to the EXT REF IN connector using the supplied coax BNC-to-coax BNC connector.

If the RF section does not have the OVEN REF OUT connector (option AY4, Delete High Precision Frequency Reference), connect a 1 MHz, 2 MHz, 5 MHz, or 10 MHz sine or square wave, with an amplitude greater than 0 dBm to the RF section's EXT REF IN connector. For best residual phase-noise, use 10 MHz with an amplitude greater than or equal to 5 dBm. See the *HP 89440A Technical Data* publication for specifications that require the high precision frequency reference.

4 Connect the RF section's 10 MHz REF TO IF SECTION connector to the IF section's EXT REF IN connector using the supplied 12-inch BNC-to-BNC cable.

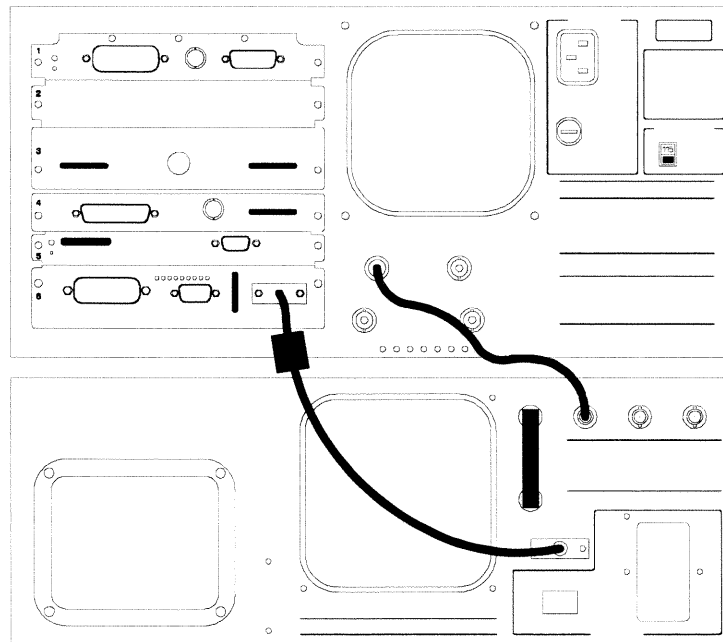

- 5** Connect the IF section's SOURCE connector to the RF section's IN connector using the supplied 8.5-inch BNC-to-BNC cable.
- 6** Connect the IF section's CHANNEL 1 connector to the RF section's OUT connector using the supplied 8.5-inch BNC-to-BNC cable.

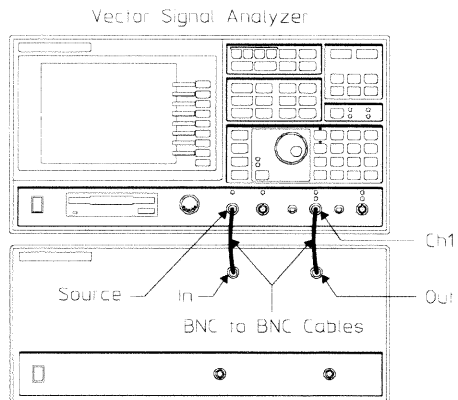

To install the analyzer

The analyzer is shipped with plastic feet in place, ready for use as a portable bench analyzer. The plastic feet are shaped to make full-width modular instruments self-align when they are stacked.

- **Install the analyzer to allow free circulation of cooling air.**
Cooling air enters the analyzer through the rear panel and exhausts through both sides.

Warning

To prevent potential fire or shock hazard, do not expose the analyzer to rain or other excessive moisture.

- **Protect the analyzer from moisture and temperatures or temperature changes that cause condensation within the analyzer.**
The operating environment specifications for the analyzer are listed in the *HP 89440A Technical Data* publication.

Caution

Use of the equipment in an environment containing dirt, dust, or corrosive substances will drastically reduce the life of the disk drive and the flexible disks. The flexible disks should be stored in a dry, static-free environment.

- **To install the analyzer in an equipment cabinet, follow the instructions shipped with the rack mount kits.**

To change the IF section's line-voltage switch

The line-voltage selector switch is set at the factory to match the most commonly used line voltage in the country of destination.

- 1 Unplug the power cord from the IF section (the section with "HP 89410A" silk screened on the lower right rear panel).
- 2 Slide the line voltage selector switch to the proper setting for the local line voltage.

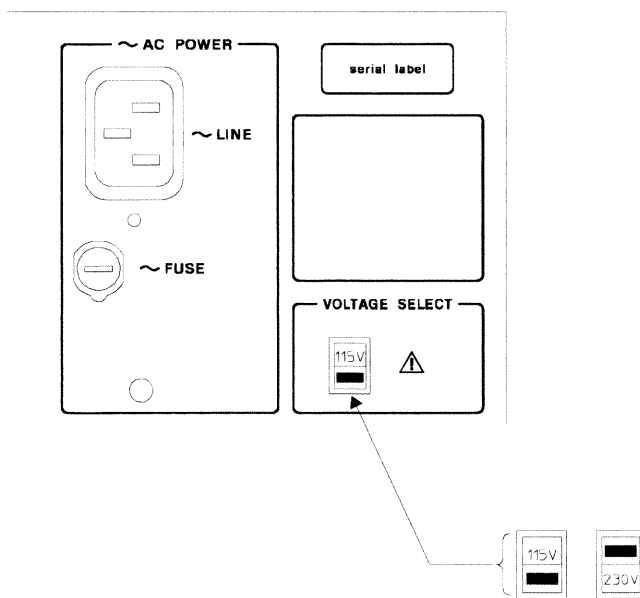

AC Line Voltage		Voltage Select Switch
Range	Frequency	
90-140 Vrms	47-440 Hz	115
198-264 Vrms	47-63 Hz	230

Warning

Only a qualified service person, aware of the hazards involved, should measure the line voltage.

To change the RF section's line-voltage switch

The line-voltage selector switch is set at the factory to match the most commonly used line voltage in the country of destination.

- 1 Unplug the power cord from the RF section (the section with "HP 89430A" silk screened on its lower left rear panel).
- 2 Using a small screw driver, pry open the power selector cover.

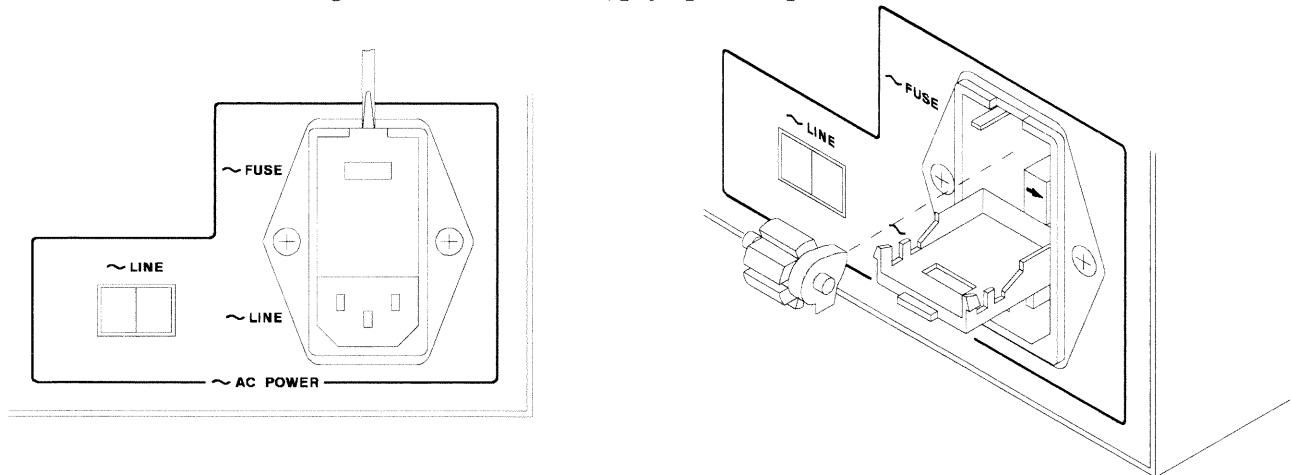

- 3 Remove the cylindrical line voltage selector.
- 4 Position the cylindrical line voltage selector so the required voltage will be facing out of the power selector, then reinstall.

AC Line Voltage

Range	Frequency	Selector Switch
90-110 Vrms	47-63 Hz	100
103-140 Vrms	47-63 Hz	120
198-242 Vrms	47-63 Hz	220
216-264 Vrms	47-63 Hz	240

Warning

Only a qualified service person, aware of the hazards involved, should measure the line voltage.

- 5 Check that the proper fuse is installed. See "To change the RF section's fuse."
- 6 Close the power selector by pushing firmly on the power selector cover.
- 7 Check that the correct line voltage appears through the power selector cover.

To change the IF section's fuse

The fuse is installed at the factory to match the most commonly used line voltage in the country of destination.

- 1 Unplug the power cord from the IF section (the section with "HP 89410A" silk screened on its lower right rear panel).
- 2 Using a small screw driver, press in and turn the fuse holder cap counter-clockwise. Remove when the fuse cap is free from the housing.

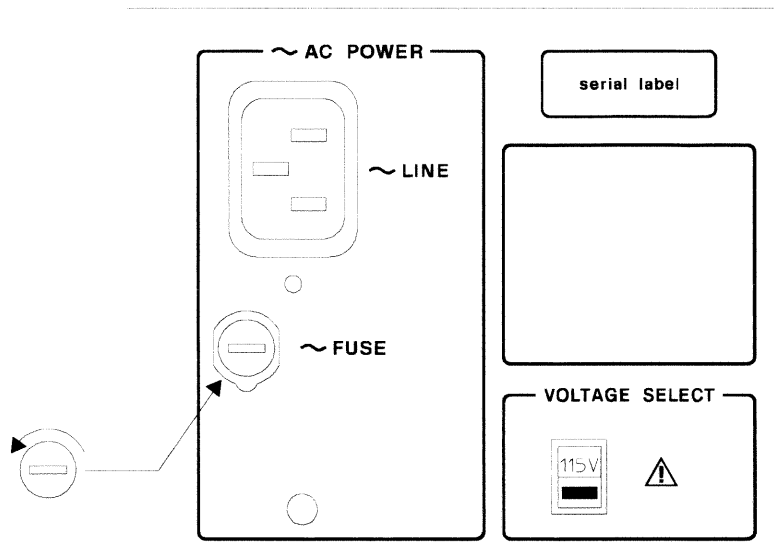

- 3 Pull the fuse from the fuse holder cap.
- 4 To reinstall, select the proper fuse and place in the fuse holder cap.

AC Line Voltage		Voltage Select Switch	Fuse	
Range	Frequency		HP Part Number	Type
90-140 Vrms	47-440 Hz	115	2110-0342	8 A 250 V Normal Blow
198-264 Vrms	47-63 Hz	230	2110-0055	4 A 250 V Normal Blow

- 5 Place the fuse holder cap in the housing and turn clockwise while pressing in.

To change the RF section's fuse

The fuse is installed at the factory to match the most commonly used line voltage in the country of destination.

- 1 Unplug the power cord from the RF section (the section with "HP 89430A" silk screened on its lower left rear panel).
- 2 Using a small screw driver, pry open the power selector cover.

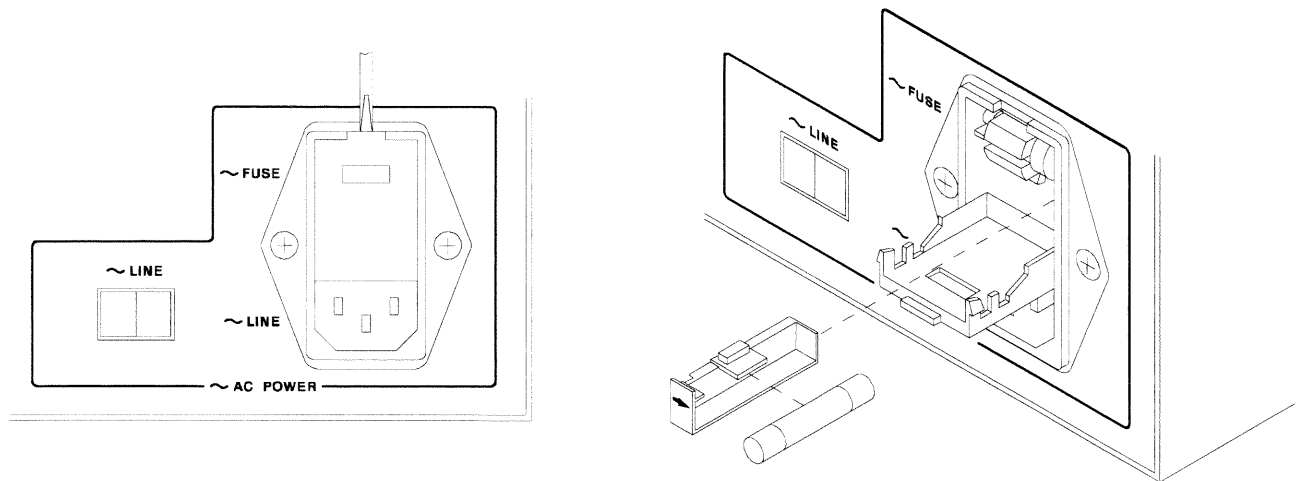

- 3 Pull the white fuse holder out of the power selector and remove the fuse from the fuse holder.
- 4 Select the proper fuse and place in the fuse holder.

AC Line Voltage		Selector Switch	Fuse	
Range	Frequency		HP Part Number	Type
90-110 Vrms	47-63 Hz	100	2110-0003	3 A 250 V Normal Blow
103-140 Vrms	47-63 Hz	120	2110-0003	3 A 250 V Normal Blow
198-242 Vrms	47-63 Hz	220	2110-0304	1.5 A 250 V Slow Blow
216-264 Vrms	47-63 Hz	240	2110-0304	1.5 A 250 V Slow Blow

- 5 Align the white arrow on top of the fuse holder with the white arrow on the power selector cover. All three arrows should point in the same direction. Push the fuse holder into the top slot of the power selector.
- 6 Close the power selector by pushing firmly on the power selector cover.
- 7 Check that the correct line voltage appears through the power selector cover.

To connect the analyzer to a LAN

Analyzers with option UFG, 4 megabyte extended RAM and additional I/O, have a ThinLAN and AUI (attachment unit interface) port for connecting the analyzer to the LAN (local area network).

- 1 Set the IF section's power switch to off (O).
- 2 Connect the ThinLAN BNC cable to the ThinLAN port or the appropriate media access unit (MAU) to the AUI port.
- 3 Set the IF section's power switch to on (|).
- 4 Press the following keys:

[Local/Setup]
[LAN setup]
[LAN port setup]
[port select **ThinLAN (BNC)**] OR [port select **AUI (MAU)**]
[IP address]
internet protocol address
[enter]
[Return]
[LAN power-on **active**]

See your LAN system administrator for the internet protocol address. Your LAN system administrator can also tell you if you need to set the gateway address or subnet mask.

To connect the analyzer to a serial device

The IF section's Serial 1 port is a 9-pin, EIA-574 port that can interface with a printer or plotter. The total allowable transmission path length is 15 meters.

- Connect the IF section's SERIAL 1 port to a printer or plotter using a 9-pin female to 25-pin RS-232-C cable.

Part Number	Cable Description
HP 24542G	9-pin female EIA-574 to 25-pin male RS-232
HP 24542H	9-pin female EIA-574 to 25-pin female RS-232

To connect the analyzer to a parallel device

The IF section's Parallel Port is a 25-pin, Centronics port. The Parallel Port can interface with PCL printers or HP-GL plotters.

- Connect the IF section's rear panel PARALLEL PORT connector to a plotter or printer using a Centronics interface cable.

To connect the analyzer to an HP-IB device

The analyzer is compatible with the Hewlett-Packard Interface Bus (HP-IB). The HP-IB is Hewlett-Packard's implementation of IEEE Standard 488.1 and 488.2. Total allowable transmission path length is 2 meters times the number of devices or 20 meters, whichever is less. Operating distances can be extended using an HP-IB Extender.

Analyzers with option UFG, 4 megabytes extended RAM and additional I/O, have an additional HP-IB connector. The additional HP-IB connector, SYSTEM INTERCONNECT, is only for connection to the spectrum analyzer that is used with the HP 89411A 21.4 MHz Down Converter.

- Connect the analyzer's rear panel HP-IB connector to an HP-IB device using an HP-IB interface cable.

Caution

The analyzer contains metric threaded HP-IB cable mounting studs as opposed to English threads. Use only metric threaded HP-IB cable lock screws to secure the cable to the analyzer. Metric threaded fasteners are black, while English threaded fasteners are silver.

For HP-IB programming information, see the *HP 89400 Series HP-IB Command Reference*.

To connect the analyzer to an external monitor

The External Monitor connector is a 15-pin connector with standard VGA pinout. The External Monitor connector can interface with an external, multi-scanning monitor. The monitor must have a 25.5 kHz horizontal scan rate, a 60 Hz vertical refresh rate, and must conform to EIA-343-A standards.

- **Connect the analyzer's rear panel EXTERNAL MONITOR connector to an external monitor using an appropriate cable.**
For additional information, see "EXTERNAL MONITOR connector" in the analyzer's online help.

To connect the optional keyboard

The analyzer may be connected to an optional external keyboard. The keyboard remains active *even when the analyzer is not in alpha entry mode*. This means that you can operate the analyzer using the external keyboard rather than the front panel. Pressing the appropriate keyboard key does the same thing as pressing a hardkey or a softkey on the analyzer's front panel.

- 1 Set the IF section's power switch to on (I).
- 2 Connect the round plug on the keyboard cable to the KEYBOARD connector on the analyzer's front panel. Make sure to align the plug with the connector pins.

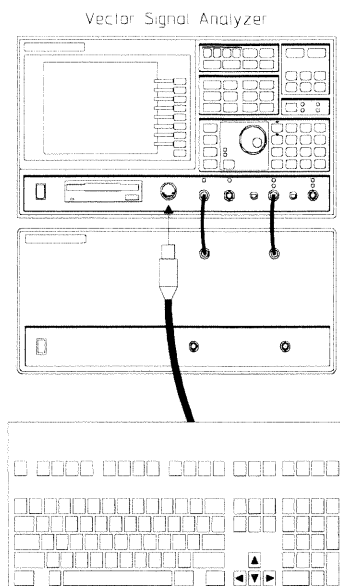

- 3 Connect the other end of the keyboard cable to the keyboard.

Caution

In addition to the U.S. English keyboard, the HP 89440A DC-1800 MHz Vector Signal Analyzer supports U.K. English, German, French, Italian, Spanish, and Swedish. Use only the Hewlett-Packard approved keyboard for this product. Hewlett-Packard does not warrant damage or performance loss caused by a non-approved keyboard. See the beginning of this guide for part numbers of approved Hewlett-Packard keyboards.

- 4** To configure your analyzer for a keyboard other than U.S. English, press **[System Utility]** [keyboard type]. Then press the appropriate softkey to select the language.

Configuring your analyzer to use a keyboard other than U.S. English only ensures that the analyzer recognizes the proper keys for that particular keyboard. Configuring your analyzer to use another keyboard *does not* localize the on-screen annotation or the analyzer's online HELP facility.

To connect the optional minimum loss pad

The minimum loss pad (option 1D7) provides a 50 ohm matched impedance to the HP 89440A and a 75 Ω matched impedance to the device under test.

- 1** Connect the minimum loss pad to the RF section's INPUT or SOURCE connector.
- 2** Connect a 75 Ω cable between the minimum loss pad and the device under test. Use either a 75 Ω type-N cable or the supplied 75 Ω type-N(m)-to-BNC(f) adapter and a 75 Ω BNC cable.

Caution

Do NOT connect a 50 Ω cable or adapter to the 75 Ω minimum loss pad. The center pin is larger in a 50 Ω type-N connector than in a 75 Ω type-N connector. Connecting a 50 Ω type-N connector to the 75 Ω minimum loss pad will damage the 75 Ω minimum loss pad.

To clean the screen

The analyzer screen is covered with a plastic diffuser screen (this is not removable by the operator). Under normal operating conditions, the only cleaning required will be an occasional dusting. However, if a foreign material adheres itself to the screen, do the following:

- 1** Set the IF section's power switch to off (O).
- 2** Remove the power cord.
- 3** Dampen a soft, lint-free cloth with a mild detergent mixed in water.
- 4** Carefully wipe the screen.

Caution

Do not apply any water mixture directly to the screen or allow moisture to go behind the front panel. Moisture behind the front panel will severely damage the instrument.

To prevent damage to the screen, do not use cleaning solutions other than the above.

To store the analyzer

- Store the analyzer in a clean, dry, and static free environment.
For other requirements, see environmental specifications in the *HP 89440A Technical Data* publication.

To transport the analyzer

- Disconnect the IF section from the RF section and package each section using the original factory packaging or packaging identical to the factory packaging. Containers and materials identical to those used in factory packaging are available through Hewlett-Packard offices.
- If returning the analyzer to Hewlett-Packard for service, attach a tag to each container describing the following:
 - Type of service required
 - Return address
 - Model number
 - Full serial number

In any correspondence, refer to the analyzer by model number and both serial numbers.
- Mark the containers **FRAGILE** to ensure careful handling.
- If necessary to package the analyzer in containers other than original packaging, observe the following (use of other packaging is not recommended):
 - Wrap each section in heavy paper or anti-static plastic.
 - Protect the front panels with cardboard.
 - Use double-wall cartons made of at least 350-pound test material.
 - Cushion each section to prevent damage.

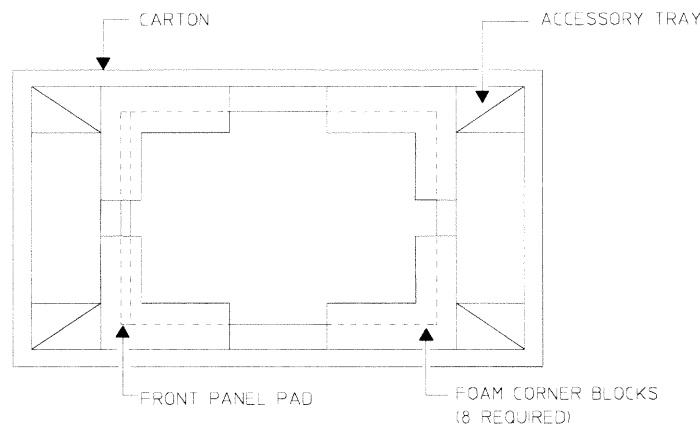

Caution

Do not use styrene pellets in any shape as packing material for the analyzer. The pellets do not adequately cushion the analyzer and do not prevent the analyzer from shifting in the carton. In addition, the pellets create static electricity which can damage electronic components.

If the IF section will not power up

- Check that the power cord is connected to the IF section and to a live power source.
- Check that the front-panel switch is on (|).
- Check that the voltage selector switch is set properly.
See “To change the IF section’s line-voltage switch” on page 1-10.
- Check that the fuse is good.
See “To change the IF section’s fuse” on page 1-12.
- Check that the IF section’s air circulation is not blocked.
Cooling air enters the IF section through the rear panel and exhausts through both sides. If the IF section’s air circulation is blocked, the IF section powers down to prevent damage from excessive temperatures. The IF section remains off until it cools down and its power switch is set to off (O) then to on (|).
- Obtain HP service, if necessary. See “Need Assistance?” at the end of this guide.

If the RF section will not power up

- Check that the power cord is connected to the RF section and to a live power source.
- Check that the RF section's rear panel and front panel power switches are on (I).
- Check that the voltage selector switch is set properly.
See "To change the RF section's line-voltage switch" on page 1-11.
- Check that the fuse is good.
See "To change the RF section's fuse" on page 1-13.
- Check that the RF section's air circulation is not blocked.
Cooling air enters the RF section through the rear panel and exhausts through both sides. If the RF section's air circulation is blocked, the RF section powers down to prevent damage from excessive temperatures. The RF section turns back on when it cools down.
- Obtain HP service, if necessary. See "Need Assistance?" at the end of this guide.

If the analyzer's stop frequency is 10 MHz

- Check that the RF section's fan is running.
If the fan is not running, see "If the RF section will not power up."
- Check that the Serial 2 port on the IF section and on the RF section are connected together.
- Press [**Instrument Mode**] and check that the receiver softkey displays "RF section (2-1800 MHz)."
If the receiver softkey does not display "RF section (2-1800 MHz)" press [receiver] [RF section (2-1800 MHz)].
- Leaving the RF section on, turn the IF section off (O) then on (|).
The IF section will not detect the RF section if the RF section was not on before the IF section performs the power-on routine.
- Obtain HP service, if necessary. See "Need Assistance?" at the end of this guide.

2

Verifying Specifications

Verifying Specifications

This chapter tells you how to use the *HP 89440A Auto Performance Test* disk. The performance test disk contains a program that semiautomates the operation verification tests and performance tests.

After you review this chapter, follow the directions in “To load the program” then continue with one of the following:

- “To run the program in semiautomated mode”
- “To run the program without a printer”
- “To run the program in manual mode”

Caution

Before applying line power to the analyzer or testing its electrical performance, see chapter 1, “Preparing the Analyzer for Use.”

Overview

The *Auto Performance Test Disk* contains a program (ITM_89440A) and two procedure files (OP_VERIFY and PERFORMAN). ITM_89440A is the test manager program. OP_VERIFY is the operation verification procedure file and PERFORMAN is the performance test procedure file. The procedure files contain an ordered list of tests, and each test contains one or more measurements. Since ITM_89440A reads the procedure files, the disk must remain in the disk drive during testing.

If you do not have a keyboard connected to the analyzer, use the numeric key pad and the alpha keys when the program prompts you to type in information. See the analyzer’s help text for a description of the alpha keys.

If a test fails, contact your local Hewlett-Packard sales and service office or have a qualified service technician see chapter 1, “Troubleshooting the Analyzer,” in the *HP 89430A Service Guide*.

Features of the Program

- The program can automatically create a printout similar to the test records at the back of this chapter.
- The program can beep when equipment connections need to be changed.
- The program can start the test sequence at any test in the operation verification or performance test list.
- The program can stop after each measurement or alternatively, only if a failure occurs.
- The program can be run in manual mode.

Test Duration

The operation verification tests require approximately four hours to complete in semiautomated mode. The performance tests require approximately five hours to complete in semiautomated mode.

Calibration Cycle

To verify that the HP 89440A DC-1800 MHz Vector Signal Analyzer is meeting its published specifications, do the performance tests every 12 months. The RF performance tests check the IF and RF sections together as a single instrument. Therefore, the RF performance tests must be repeated if the RF section is connected to a different IF section.

Recommended Test Equipment

The following table lists the recommended equipment needed to test the performance of the HP 89440A DC-1800 MHz Vector Signal Analyzer. Other equipment may be substituted for the recommended model if it meets or exceeds the listed critical specifications. The table also identifies the test equipment that is controlled by this program. If you use a test instrument that is not controlled by the program, the program prompts you to set the instrument state during testing.

Also, if you want the test record to be automatically printed, you need an HP-IB printer. If you want the printer to automatically leave top and bottom margins on every page, enable perforation skip mode (see your printer's manual for directions). If you do not have an HP-IB printer you must record the results of each test in the test records. These test records may be reproduced without written permission of Hewlett-Packard.

Recommended Test Equipment

Instrument	Critical Specifications	Recommended Model
Baseband Spectrum Analyzer	Frequency range 100 Hz to 40 MHz Amplitude range -60 to +15 dBm Dynamic range < -67 dBc Tracking Source @ 0 dBm Impedance 50 Ω and 75 Ω External reference input	HP 3585B† Alternate HP 3585A† HP 3588A† HP 3589A†
Digital Multimeter	10 M Ω range Accuracy $\pm 0.5\%$	HP 3458A† Alternate HP 3455A† HP 3456A† HP 3478A†
Frequency Standard	Accuracy ± 0.5 ppm	HP 5061B
Frequency Synthesizer	Frequency range 3 Hz to 10 MHz Amplitude range -36 to +20 dBm Amplitude resolution 0.01 Hz Impedance 50 Ω Harmonic distortion < -30 dBc Spurious < -70 dBc External reference input	HP 3326A† Alternate HP 3325A† HP 3325B†
Milliwatt Power Meter	Range ± 0.2 dBm Accuracy ± 0.0625 dB	W&G EPM-1‡
Power Meter	Accuracy ± 0.125 dB	HP 438A† Alternate HP 436A†
Power Sensor	Frequency range 2 to 1800 MHz Compatible with power meter	HP 8482A
RF Spectrum Analyzer	Frequency range 2 MHz to 4 GHz Amplitude range -60 to +15 dBm Dynamic range < -67 dBc Impedance 50 Ω External reference input Amplitude accuracy ± 1 dB Frequency accuracy ± 125 Hz at 600 MHz	HP 8566B† Alternate HP 8566A†
Signal Generator	Frequency range 2 MHz to 1.8 GHz Amplitude range -30 to +20 dBm Impedance 50 Ω Spurious < -82 dBc External reference input	HP 8663A†

† Program controlled test equipment.

‡ Wandel & Goltermann Inc., 1800 Wyatt Drive, Suite 2, Santa Clara, CA 95054 U.S.A. (408) 988-7622

Recommended Test Equipment (continued)

Instrument	Critical Specifications	Recommended Model
Synthesizer/Level Generator	Frequency range 30 kHz to 74 MHz Amplitude range -56 to +13 dBm Amplitude accuracy ± 0.25 dB Impedance 50 Ω Spurious < -70 dBc External reference input	HP 3335A†
1 dB step attenuator (with cal data @ 10 MHz)	Range 0 to 8 dB Accuracy ± 0.03 dB	HP 8494G‡ Alternate HP 355C HP 8494A HP 8494B HP 8494H‡
10 dB step attenuator (with cal data @ 10 MHz)	Range 0 to 70 dB Accuracy ± 0.03 dB	HP 8495G‡ Alternate HP 355D HP 8495A HP 8495B HP 8495H‡ HP 8496A HP 8496B HP 8496G‡ HP 8496H‡
50 Ω Directional Bridge	Frequency range 100 kHz to 10 MHz Directivity > 40 dB	HP 35677-63502 Alternate HP 8721A ††
75 Ω Directional Bridge	Frequency range 100 kHz to 10 MHz Directivity > 40 dB	HP 35677-63504 Alternate HP 8721A opt 008 ††
Power Splitter	SWR ≤ 1.10 Impedance 50 Ω Two output ports	HP 11667A
200 MHz Low Pass Filter	Rejection > 52 dB Impedance 50 Ω	Daden # LA 200-10NN ††
1000 MHz Low Pass Filter	Rejection > 52 dB Impedance 50 Ω	Daden # LA 1000-10NN ††
50 Ω Feedthrough Termination (2 required for opt AY7)	Accuracy $\pm 0.2\%$	HP 11048C

† Program controlled test equipment.

‡ Program controlled test equipment via HP 11713A Attenuator/Switch Driver (drives two attenuators).

†† This equipment will not meet 4:1 measurement uncertainty.

‡‡ Daden Associates Inc., 23011 Moulton Parkway, A-12, Laguna Hills, CA 92653 U.S.A. (714) 368-1522
FAX (714) 366-9600

Recommended Test Equipment (continued)

Instrument	Critical Specifications	Recommended Model
5 MHz Low Pass Filter	Rejection > 52 dB Impedance 50 Ω	TTE # J87-5M-50-613B ‡
10 MHz Low Pass Filter	Rejection > 52 dB Impedance 50 Ω	TTE #J87-10M-50-613B‡
100 kΩ Series Resistor†	Value 100 kΩ Accuracy ±1% Power 0.25 W	HP 0757-0465
Cables	(4) 50 Ω BNC 75 Ω BNC (2) 50 Ω Type-N	HP 8120-1840 HP 8120-0688 HP 15000C (24 inch) or HP 15000D (60 inch)
Adapters	BNC Tee (3) N(m)-to-BNC(f) N(f)-to-BNC(f) BNC(f)-to-Dual Banana Plug(m) BNC(f)-to-BNC(f) N(m)-to-BNC(m) 50 Ω N(m)-to-BNC(m) 75 Ω (2) SMA(m)-to-BNC(f)	HP 1250-0781 HP 1250-0780 HP 1250-1536 HP 1251-2277 HP 1250-0080 HP 1250-1473 HP 1250-1533 HP 1250-1462

† See "Suggested Assembly for Series Resistor."

‡ TTE Inc., 2251 Barry Ave, Los Angeles, CA 90064-1400 U.S.A. (310) 445-2791

Suggested Assembly for Series Resistor

The following is a suggested assembly for the 100 kΩ series resistor. The 100 kΩ series resistor is required for the Input Capacitance performance test.

- 1 Cut resistor leads to 12 mm on each end.
- 2 Solder one resistor lead to the center conductor of the BNC female connector.
- 3 Solder the conductor center pin to the other lead of the resistor.
- 4 Screw the sleeve and the BNC male connector into place. Tighten securely.

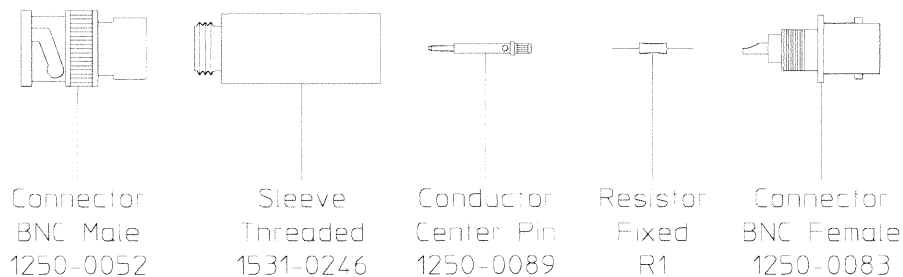

Measurement Uncertainty

A table starting on page 2-80 lists the measurement uncertainty and ratio for each performance test using the recommended test equipment. Except for the Intermodulation Distortion performance test, the ratios listed for the recommended test equipment meet or exceed the measurement uncertainty ratio required by U.S. MIL-STD-45662A. The table also provides a place to record the measurement uncertainty and ratio for each performance test using equipment other than the recommended test equipment. The table may be reproduced without written permission of Hewlett-Packard.

Operation Verification and Performance Tests

The operation verification tests give a high confidence level (>90%) that the HP 89440A DC-1800 MHz Vector Signal Analyzer is operating properly and within specifications. The operation verification tests are a subset of the performance tests. The operation verification tests should be used for incoming and after-repair inspections. The performance tests provide the highest level of confidence and are used to verify that the HP 89440A DC-1800 MHz Vector Signal Analyzer conforms to its published specifications. Some repairs require a performance test to be done after the repair. The following table lists the operation verification and performance tests.

Operation Verification	Performance Tests
Self Test Amplitude Accuracy Amp_Phase Match Input_Coupling Input Trigger External Trigger External Arm Harmonic Distortion DC Offset Spurious Signals Noise Source Amplitude Accuracy Source Distortion RF-Amplitude Accuracy Phase Noise RF-Spurious Signals RF-Harmonic Distortion Frequency Accuracy RF-Noise RF-Source Amplitude Accuracy RF-Source IF-Flatness RF-Source Distortion RF-Source Noise	Self Test Amplitude Accuracy Amplitude Linearity Amp_Phase Match Intermodulation Distortion Input Coupling Input Trigger External Trigger External Arm Harmonic Distortion Input Capacitance Input Resistance DC Offset Spurious Signals Noise Cross Talk Anti-Alias Filter Source Amplitude Accuracy Input Rtn Loss Source Rtn Loss Source Distortion RF-Amplitude Accuracy Phase Noise LO Spurs RF-Spurious Signals RF-Harmonic Distortion Frequency Accuracy RF-Noise RF-Source Amplitude Accuracy RF-Source IF-Flatness RF-Source Distortion RF-Source Noise

Specifications and Performance Tests

The specifications are listed in the *HP 89440A Technical Data* publication that was shipped with this guide. The following table lists specifications and the performance test or tests that verify each specification.

Specification	Performance Test
RF	
Frequency	
Stability	
Phase noise	Phase Noise
LO spurious sidebands	LO Spurs
Amplitude	
Accuracy	
Absolute full-scale accuracy	RF-Amplitude Accuracy
Dynamic range	
Harmonic distortion	RF-Harmonic Distortion
General spurious	RF-Spurious Signals
Input noise density	RF Noise
Source	
Amplitude	
Absolute accuracy at 6 MHz	RF-Source Amplitude Accuracy
IF flatness	RF-Source IF-Flatness
Dynamic range	
Harmonic	RF-Source Distortion
Average noise level	RF-Source Noise

Specification	Performance Test
Baseband	
Frequency	
Frequency accuracy	Frequency Accuracy
Amplitude	
Amplitude accuracy	
Absolute full-scale accuracy	Amplitude Accuracy
Amplitude linearity	Amplitude Linearity
Residual dc	DC Offset
Dynamic range	
Harmonic distortion	Harmonic Distortion
Intermodulation distortion	Intermodulation Distortion
Residual (spurious) responses	Spurious Signals
Input noise density	Noise
Crosstalk	Cross Talk
Alias responses	Anti-Alias Filter
Input port	
Coupling	Input Coupling
Impedance	Input Capacitance
Impedance	Input Resistance
Return loss	Input Rtn Loss
Two-channel	
Channel match	Amp Phase Match
Trigger	
Input channel trigger	Input Trigger
External trigger	External Trigger
External arm	External Arm
Source	
Amplitude	
Amplitude accuracy	Source Amplitude Accuracy
Harmonic and other spurious products	Source Distortion
Source port	
Return loss	Source Rtn Loss

To load the program

For information about the program's softkeys, see the menu descriptions near the end of this chapter.

- 1** Set the HP 89440A DC-1800 MHz Vector Signal Analyzer's power switch for the IF section to off (\circ), then connect the analyzer, test instruments, and printer using HP-IB cables.
- 2** Insert the *HP 89440A Auto Performance Test* disk into the analyzer's disk drive, then set the IF section's power switch to on (\uparrow).
The RF section must be on before the IF section is turned on.
- 3** If you have the optional PC Style Keyboard, connect the keyboard to the analyzer using the keyboard cable (see "To connect the optional keyboard" in chapter 1).
- 4** After the analyzer finishes its power-up calibration routine, press the following keys:

[Local/Setup]

[system controller]

[System Utility]

[memory usage]

[configure meas memory]

[max freq pts]

1601

[enter]

[num math temp]

6

[enter]

[Return]

[Return]

[more]

[diagnostics]

[performance test]

To load the program

If you get an insufficient memory message, press the following keys then return to the procedure:

[System Utilities]

[memory usage]

[remove RAM disk]

[confirm remove]

If you get a wrong disk message after you press the performance test softkey, check that the correct disk is installed and that the analyzer is properly configured (see “If the analyzer’s stop frequency is 10 MHz” at the end of chapter 1).

5 Now go to one of the following procedures to continue:

- “To run the program in semiautomated mode”
- “To run the program without a printer”
- “To run the program in manual mode”

To run the program in semiautomated mode

You must have an HP-IB printer connected to your system to run the program in semiautomated mode. If you do not have a printer, see “To run the program without a printer” later in this chapter.

- 1** Press the following keys and when the program prompts you, type in the information for the title page of the test record and press [enter]:

[TITLE PAGE]
[TEST FACILITY]
[FACILITY ADDRESS]
[TESTED BY]
[REPORT NUMBER]
[CUSTOMER]
[MORE]
[TEMP]
[HUMIDITY]
[LINE FREQUENCY]
[RETURN]

- 2** Press the following keys and when the program prompts you, type in the equipment configuration information:

[EQUIP CONFIG]
[SYNTHESIZER]
[SYNTH/ LVL GEN]
[BASEBAND ANALYZER]
[MULTIMETER]
[MORE]
[STEP_ATT 1DB]
[STEP_ATT 10DB]
[SIGNAL GENERATOR]
[POWER METER]
[POWER SENSOR]
[mW-POWER METER]
[MORE]
[RF ANALYZER]
[RETURN]

The HP-IB address is $100 \times (\text{interface select code}) + (\text{primary address})$. The interface select code for the test equipment and printer is 7 (for example, if the primary address is 8, the HP-IB address is 708).

When entering the calibration due date, only four characters are displayed on the screen. However, you can enter up to nine characters and they will be printed.

To run the program in semiautomated mode

3 Press the following keys and type in the printer address when the program prompts you:

[TEST CONFIG]
[PRINTER ADDRESS]
[PROCEDURE]
[OP_VERIFY] or [PERFORMAN]
[STOP AFTER]
[LIMIT FAILURE] or [NONE]
[RETURN]

4 Press the following keys to start the test:

[START TESTING]
[START BEGINNING]

When you select [START BEGINNING], the data is written to a file on the disk and printed only after all tests are done. When you select [START MIDDLE] or [ONE TEST], the data is printed immediately after each measurement.

5 Follow the directions on the display.

The directions on the display briefly tell you how to connect test equipment. For detailed illustrations of equipment setup, see the setup illustrations starting on page 2-18.

If you want to pause the program and return the HP 89440A DC-1800 MHz Vector Signal Analyzer to front panel control, press [**BASIC**]. To continue the program, press [**Display**] [BASIC display format] [lower] [**BASIC**] [continue]. If you changed any instrument setup states, press [RESTART TEST] to ensure accurate measurement results.

To run the program without a printer

Use this procedure if you do not have an HP-IB printer connected to your system.

- 1** Write in the information needed on the title page of the “Performance Test Record” or the “Operation Verification Test Record” (located near the back of this chapter).
- 2** Press the following keys and when the program prompts you, type in the model number and HP-IB address:

```
[EQUIP CONFIG]
[SYNTHESIZER]
[SYNTH/ LVL GEN]
[BASEBAND ANALYZER]
[MULTIMETER]
[MORE]
[STEP_ATT 1DB]
[STEP_ATT 10DB]
[SIGNAL GENERATOR]
[POWER METER]
[POWER SENSOR]
[mW-POWER METER]
[MORE]
[RF ANALYZER]
[RETURN]
```

The HP-IB address equals $100 \times (\text{interface select code}) + (\text{primary address})$. The interface select code for the test equipment and printer is 7 (for example, if the primary address is 8, the HP-IB address is 708).

- 3** Press the following keys:

```
[TEST CONFIG]
[PROCEDURE]
[OP_VERIFY] or [PERFORMAN]
[STOP AFTER]
[EACH MEASUREMENT]
[RETURN]
```
- 4** Press the following keys to start the test:

```
[START TESTING]
[START BEGINNING]
```

- 5** Now follow the directions on the display and record every measurement result in the “Performance Test Record” or the “Operation Verification Test Record.” The directions on the display briefly tell you how to connect test equipment. For detailed illustrations of equipment setup, see the setup illustrations starting on page 2-18.

If you want to pause the program and return the HP 89440A DC-1800 MHz Vector Signal Analyzer to front panel control, press [**BASIC**]. To continue the program, press [**Display**] [BASIC display format] [lower] [**BASIC**] [continue]. If you changed any instrument setup states, press [RESTART TEST] to ensure accurate measurement results.

To run the program in manual mode

Use this procedure if you want to run the program in manual mode. You will be prompted to set up all test equipment and you can check the analyzer's setup state after each measurement.

1 Press the following keys and when the program prompts you, set all HP-IB addresses to 0:

[EQUIP CONFIG]
[SYNTHESIZER]
[SYNTH/ LVL GEN]
[BASEBAND ANALYZER]
[MULTIMETER]
[MORE]
[STEP_ATT 1DB]
[STEP_ATT 10DB]
[SIGNAL GENERATOR]
[POWER METER]
[POWER SENSOR]
[mW-POWER METER]
[MORE]
[RF ANALYZER]
[RETURN]

2 Press the following keys:

[TEST CONFIG]
[PROCEDURE]
[OP_VERIFY] or [PERFORMAN]
[STOP AFTER]
[EACH MEASUREMENT]
[RETURN]

3 Press the following keys to start the test:

[START TESTING]
[START BEGINNING]

4 Now follow the directions on the display and record the measurement result in the test record after every measurement.

If you want to view the analyzer's setup state, press **[BASIC]** **[View State]** [measurement state] or [input/source state]. To continue the program, press **[Display]** [BASIC display format] [lower] **[BASIC]** [continue]. If you changed any instrument setup states, press **[RESTART TEST]** to ensure accurate measurement results.

The directions on the display briefly tell you how to connect test equipment. For detailed illustrations of equipment setup, see the setup illustrations starting on the next page.

To set up the self test

Performance Test and Operation Verification

This test checks the measurement hardware in the HP 89440A. No performance tests should be attempted until the analyzer passes this test. This test takes approximately one minute to complete and requires no external equipment.

1

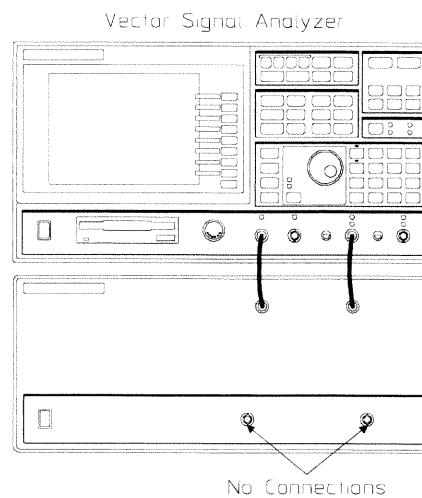

To set up the amplitude accuracy test

Performance Test and Operation Verification

This test verifies that the HP 89440A meets its baseband amplitude accuracy specification for absolute full scale accuracy. In this test, the output of the synthesizer is connected to a 1 dB and a 10 dB step attenuator. With the attenuators set to 20 dB, the synthesizer's amplitude is adjusted for a 0 dBm reading on the milliwatt power meter. The output of the attenuators is then connected to the HP 89440A, and the attenuators are set for the desired output level. This test checks -30, -18, -6, +6, and +18 dBm at 9.876 MHz and 49.234 kHz in the 50 ohm and 1 Mohm impedance paths. The following lists the attenuator settings for each amplitude:

Amplitude	-30 dBm	-18 dBm	-6 dBm	+6 dBm	+18 dBm
10 dB Step Attenuator	50 dB	30 dB	20 dB	10 dB	0 dB
1 dB Step Attenuator	0 dB	8 dB	6 dB	4 dB	2 dB

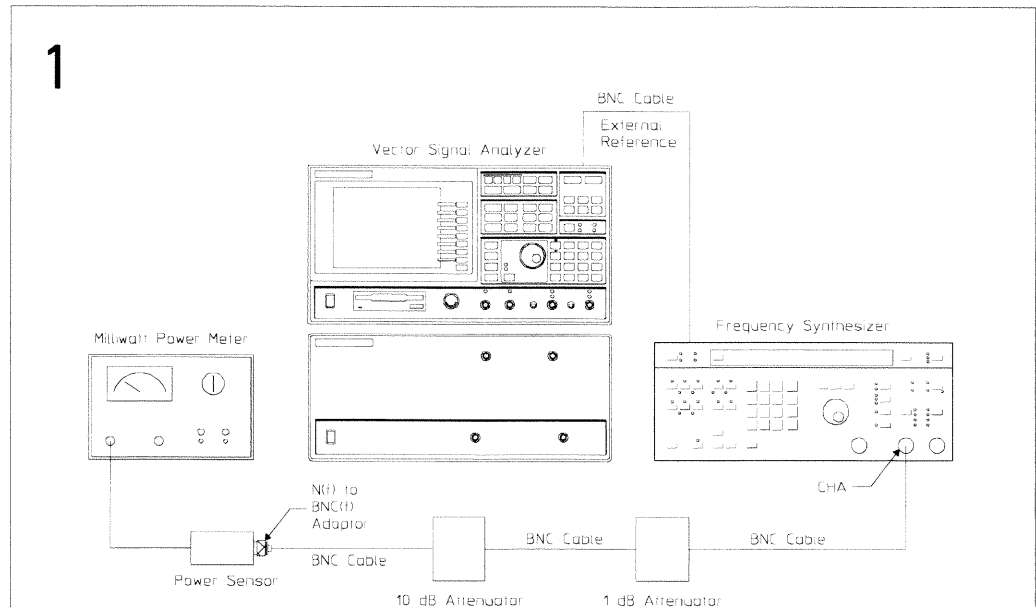

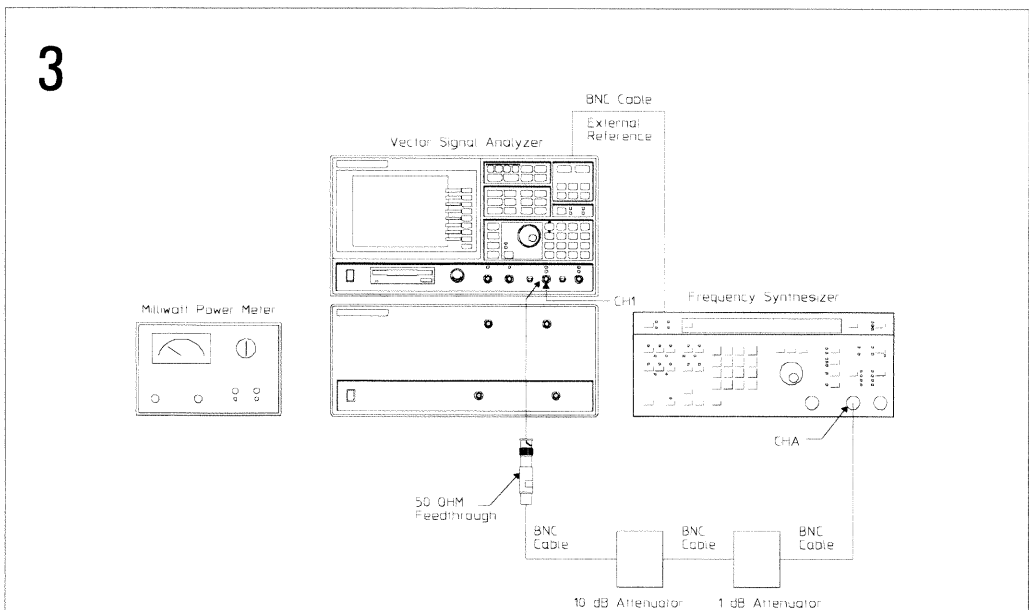
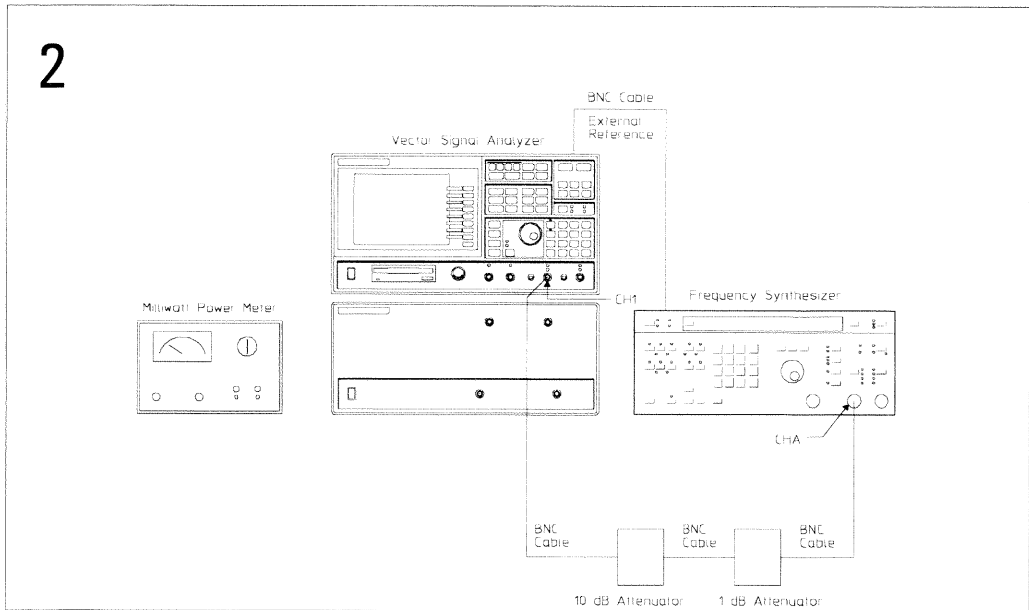

4 Option AY7 only

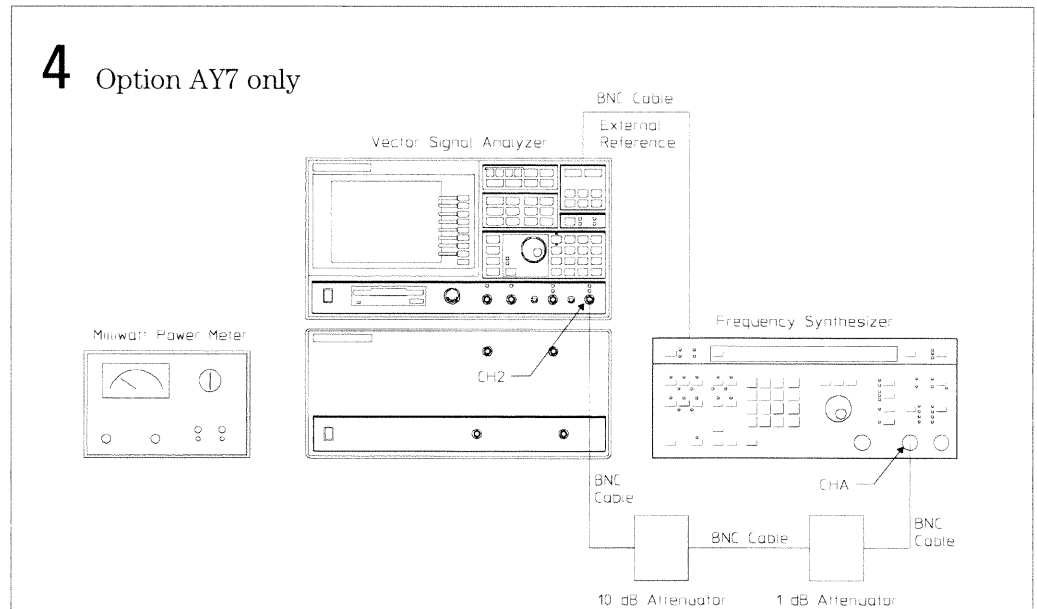

5 Option AY7 only

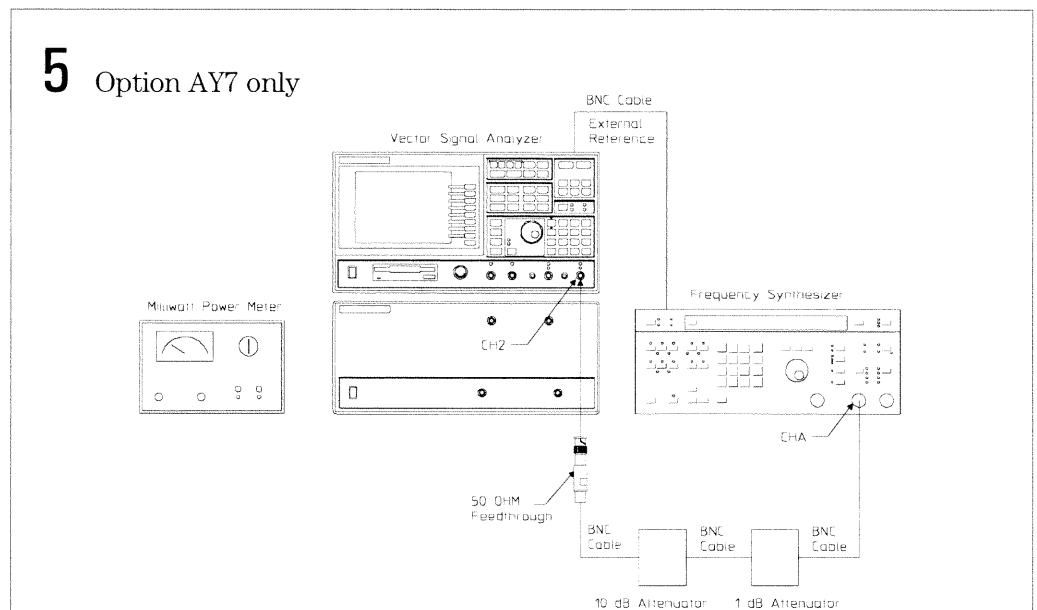

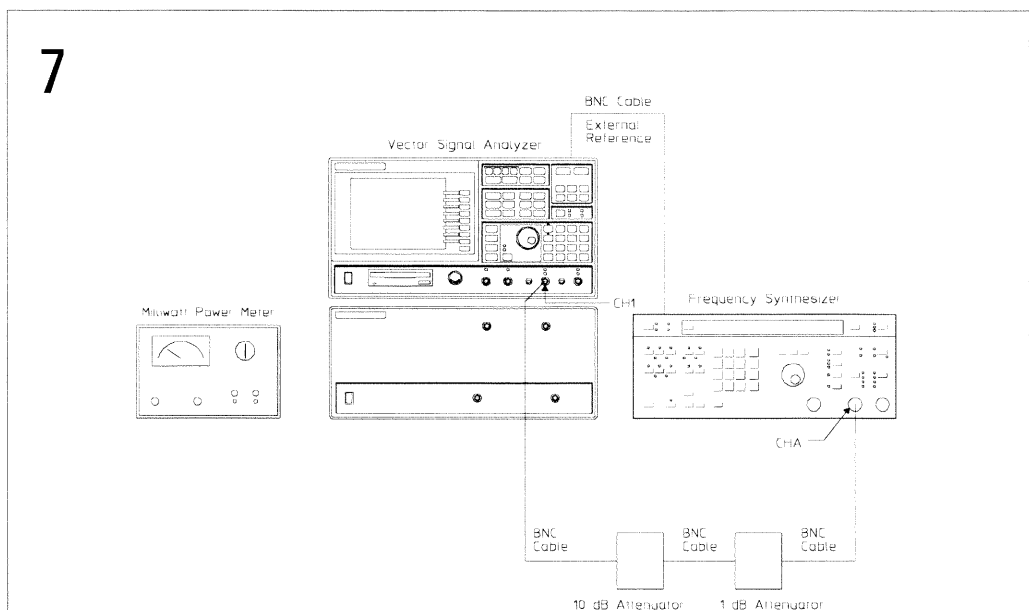
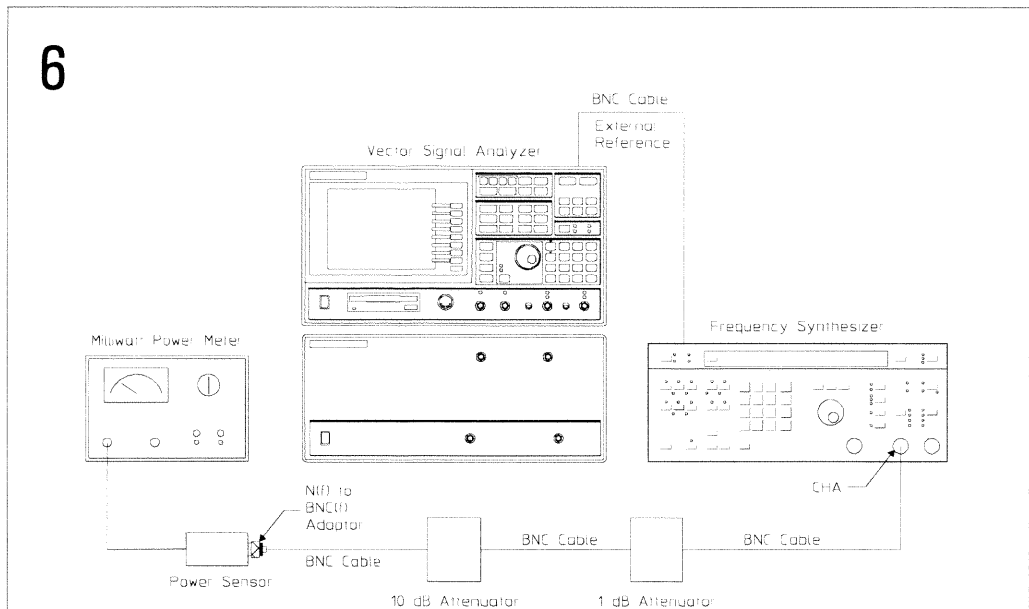

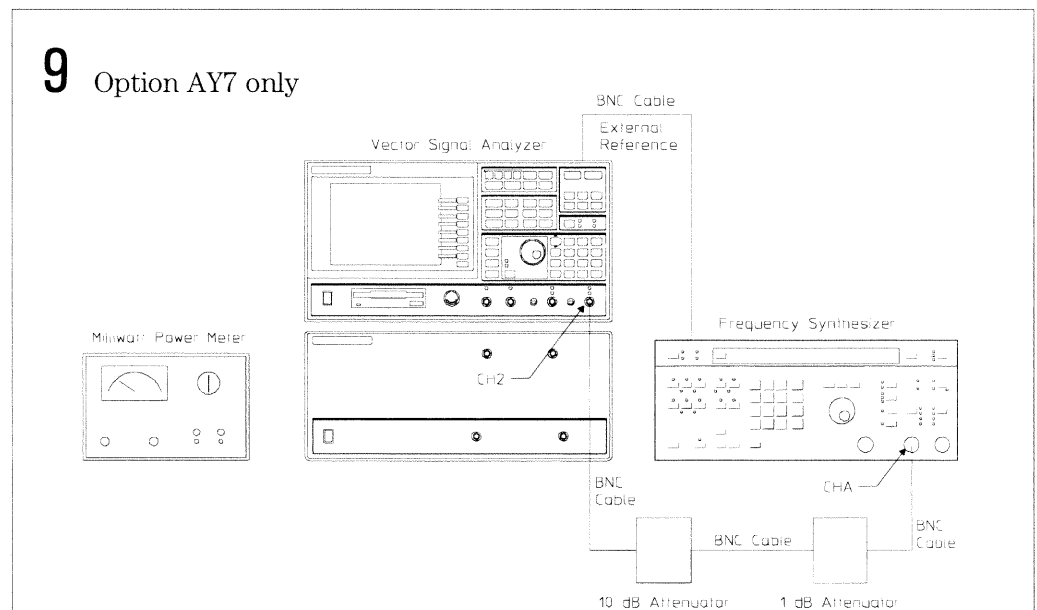
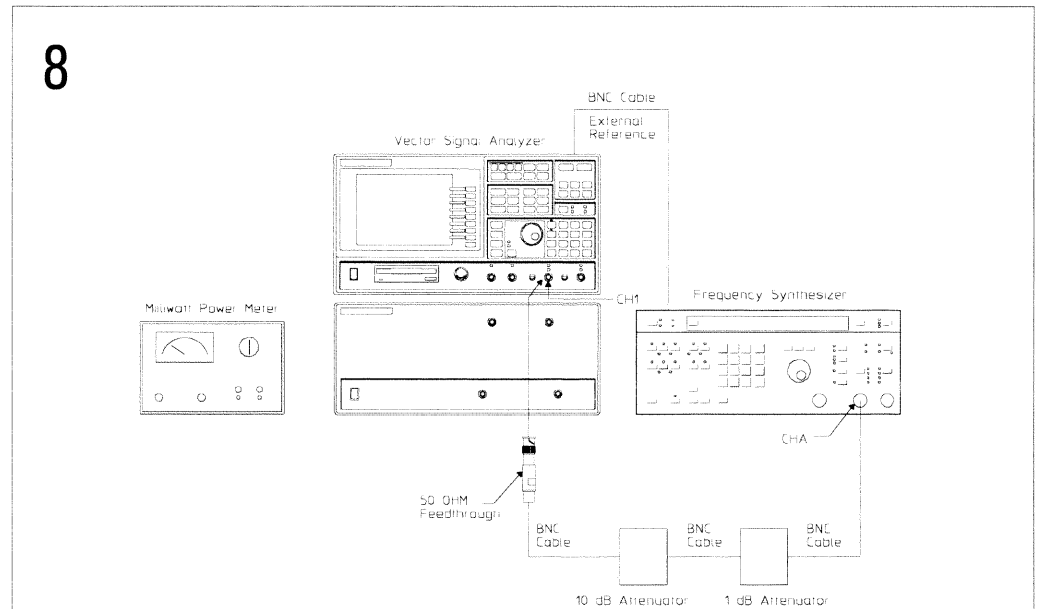

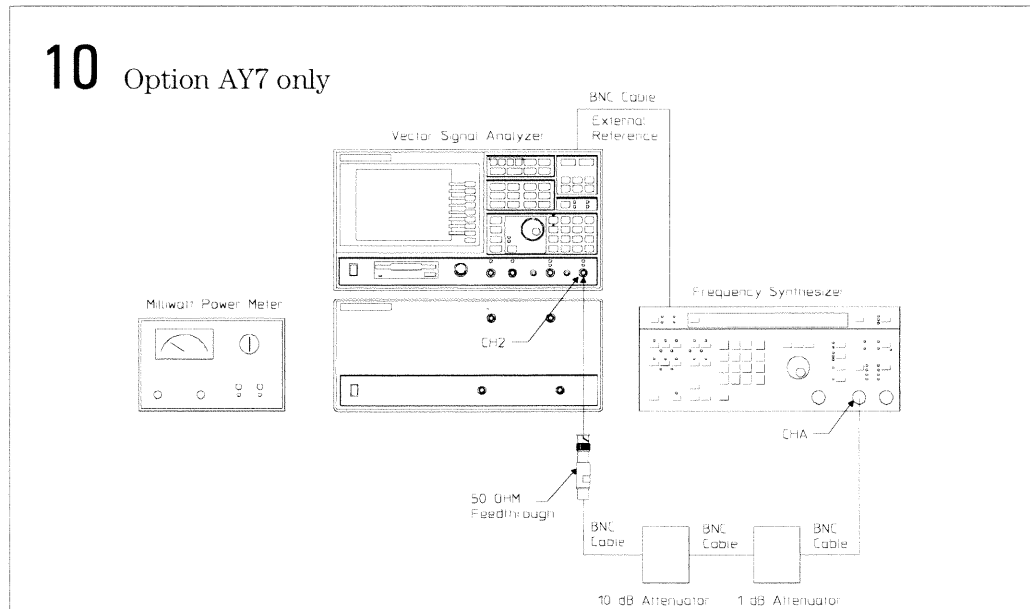

To set up the amplitude linearity test

Performance Test only

This test verifies that the HP 89440A meets its baseband amplitude accuracy specification for amplitude linearity. In this test, the IF source is connected to the IF channel 1 or 2 through a 10 dB step attenuator. With the attenuator set to 0 dB, the IF source's output is adjusted for a full scale input. The attenuator is then set to 10 dB and amplitude linearity is checked at -10 dBm. This test checks amplitude linearity at -10 , -20 , -30 , -40 , -50 , -60 and -70 dB. The source is set to 9.53 MHz, and the 10 dB step attenuator is set to 10, 20, 30, 40, 50, 60 and 70 dB.

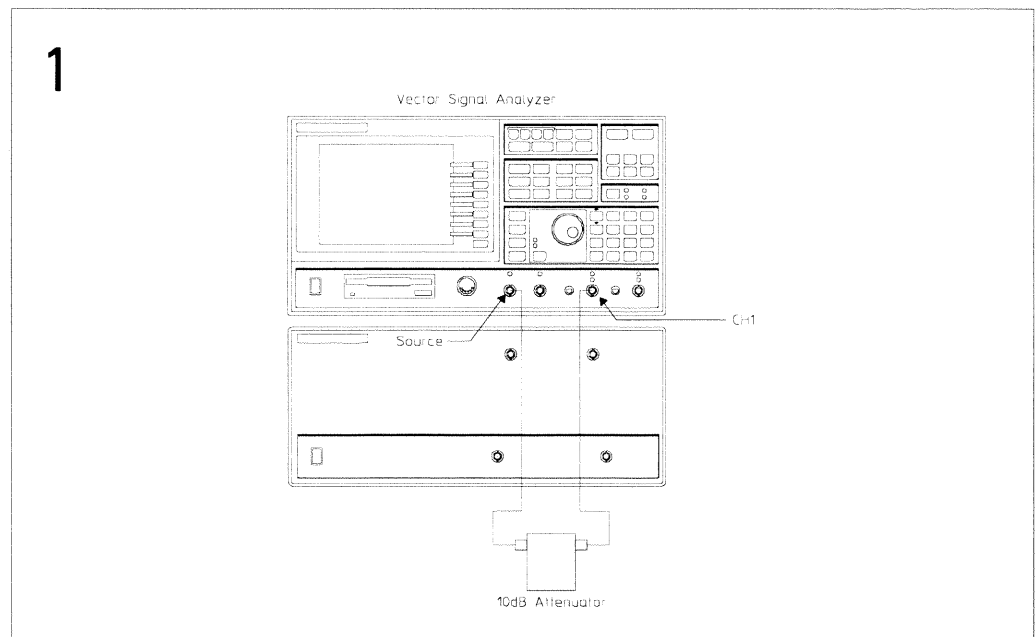

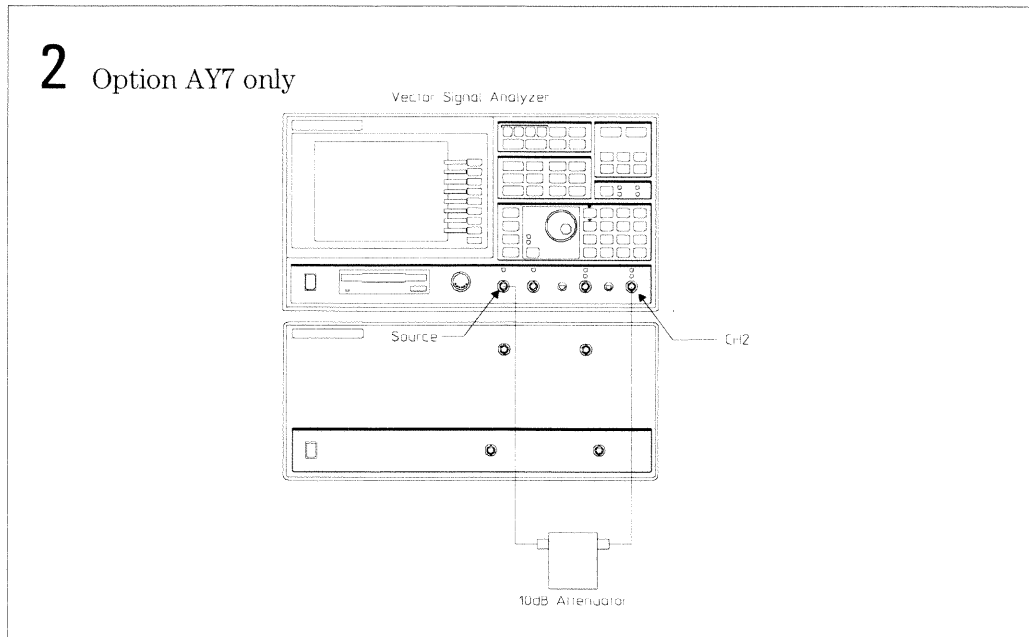

To set up the amp_phase match test

Performance Test and Operation Verification

This test is only for HP 89440A's with the optional second channel (option AY7). This test verifies that the HP 89440A, option AY7, meets its baseband two-channel specification for channel match. In this test, the HP 89440A's source outputs a periodic chirp signal to the power splitter. The power splitter and cables are calibrated by making two measurements and storing the data in the internal data registers. A calibration trace is then computed using the HP 89440A's math capabilities. Channel match is then measured using the calibration trace to correct for inaccuracies in the power splitter and cables.

1 Option AY7 only

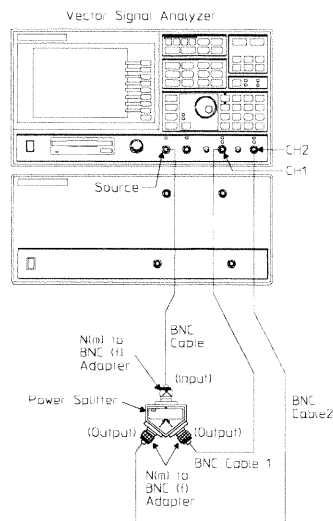

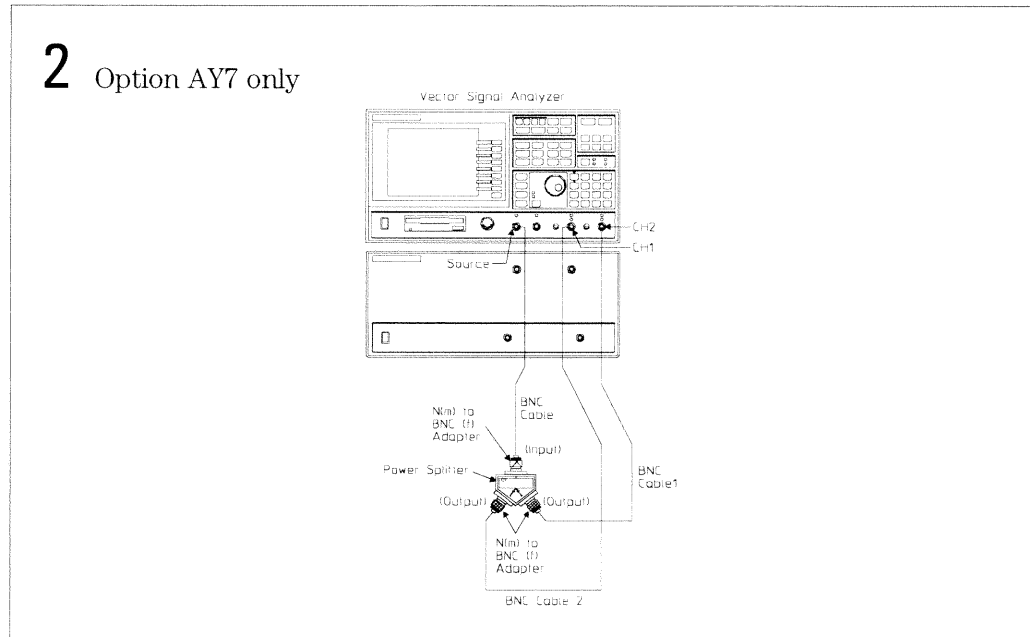

To set up the intermodulation distortion test

Performance Test only

This test verifies that the HP 89440A meets its baseband dynamic range specification for intermodulation distortion. In this test, two signals (176.543 kHz and 177.530 kHz) are mixed to provide the HP 89440A with a modulated signal. Anytime two signals are mixed, the resultant signal includes the two fundamental frequencies plus their sum and difference frequencies (the sum and difference frequencies are the intermodulation products). The amplitude of each intermodulation product is then measured with the HP 89440A. The synthesizer is set to -36 dBm.

1 Using an HP 3326A

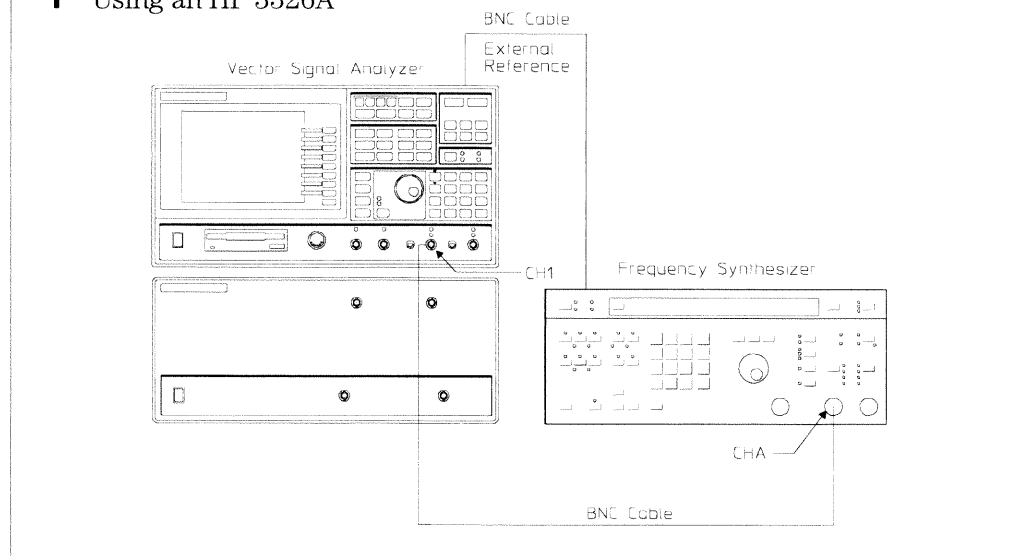

2 Using an HP 3326A/Option AY7 only

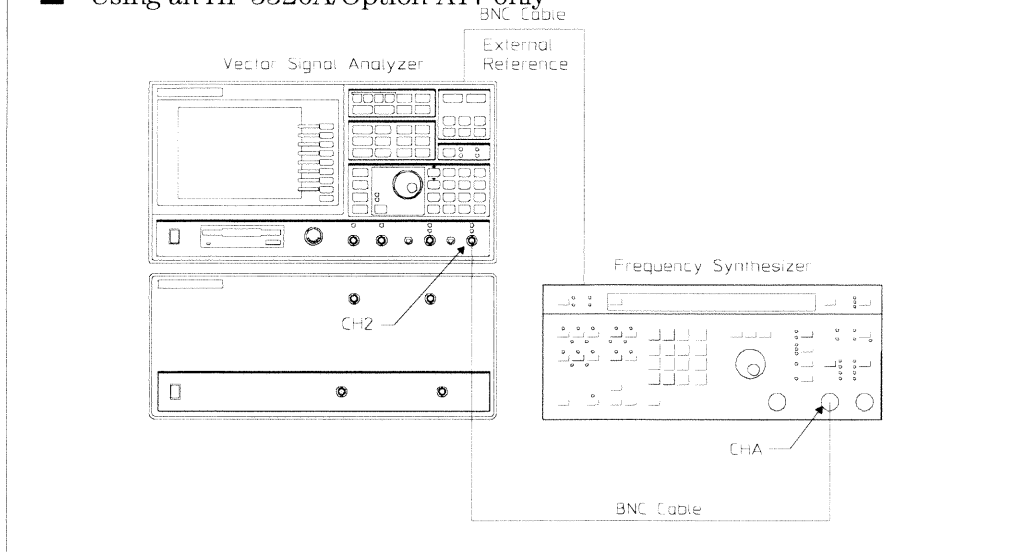

1A Alternate

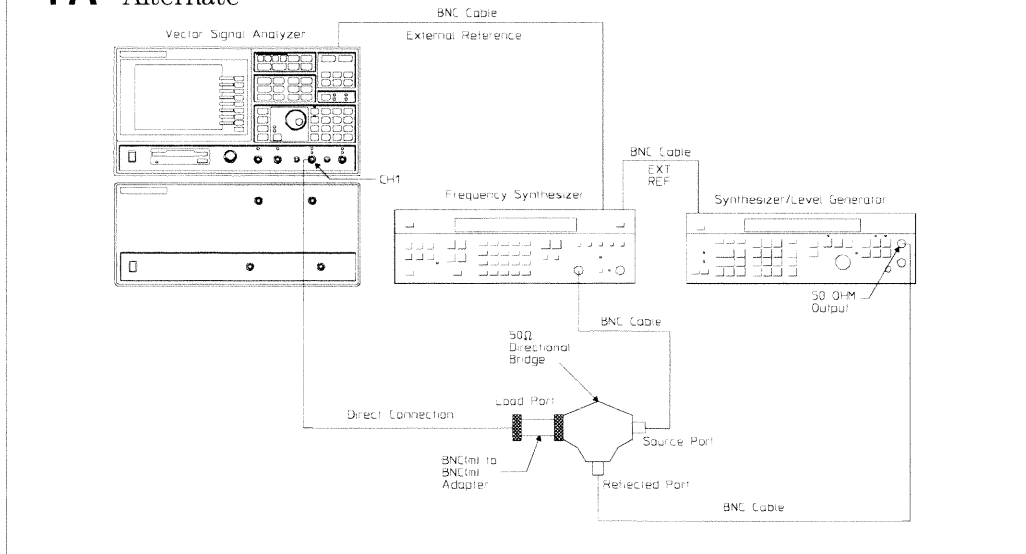

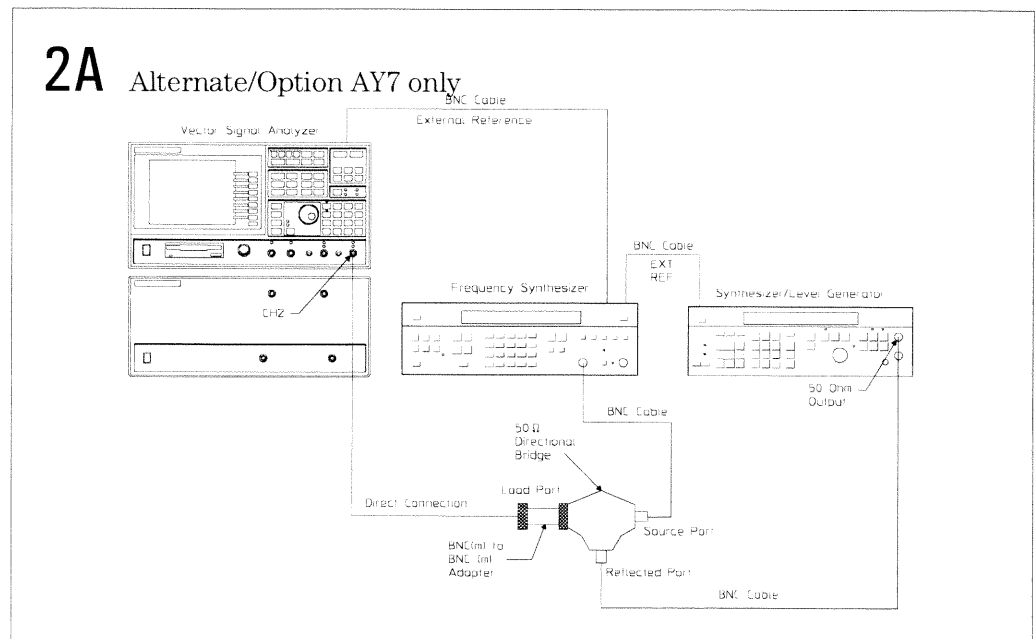

To set up the input coupling test

Performance Test and Operation Verification

This test verifies that the HP 89440A meets its baseband input port specification for coupling. In this test, the amplitude of a 3 Hz signal is measured in both ac and dc coupled modes. The values measured determine insertion loss.

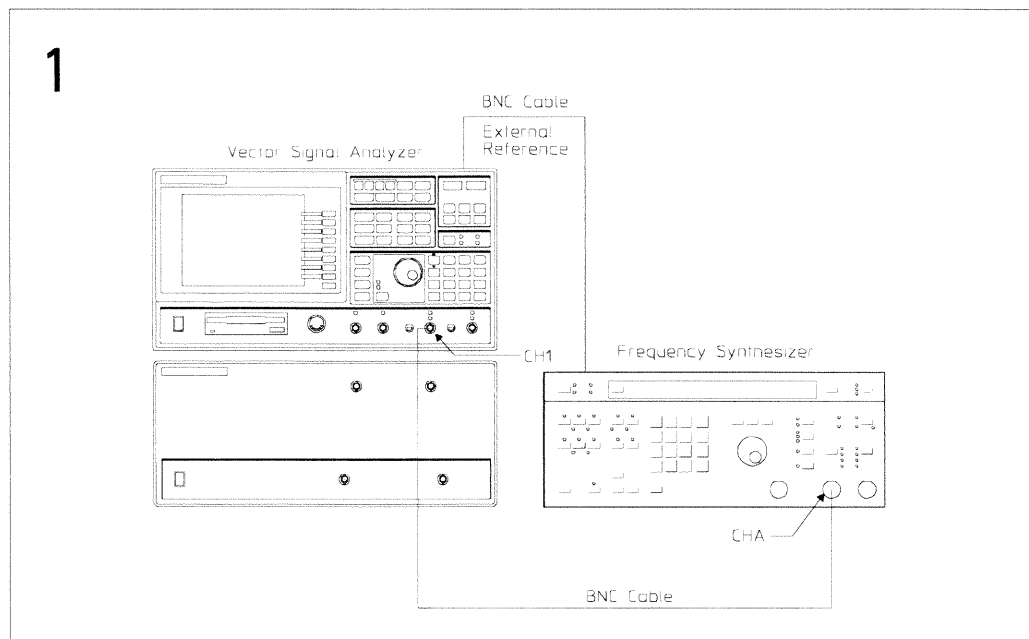

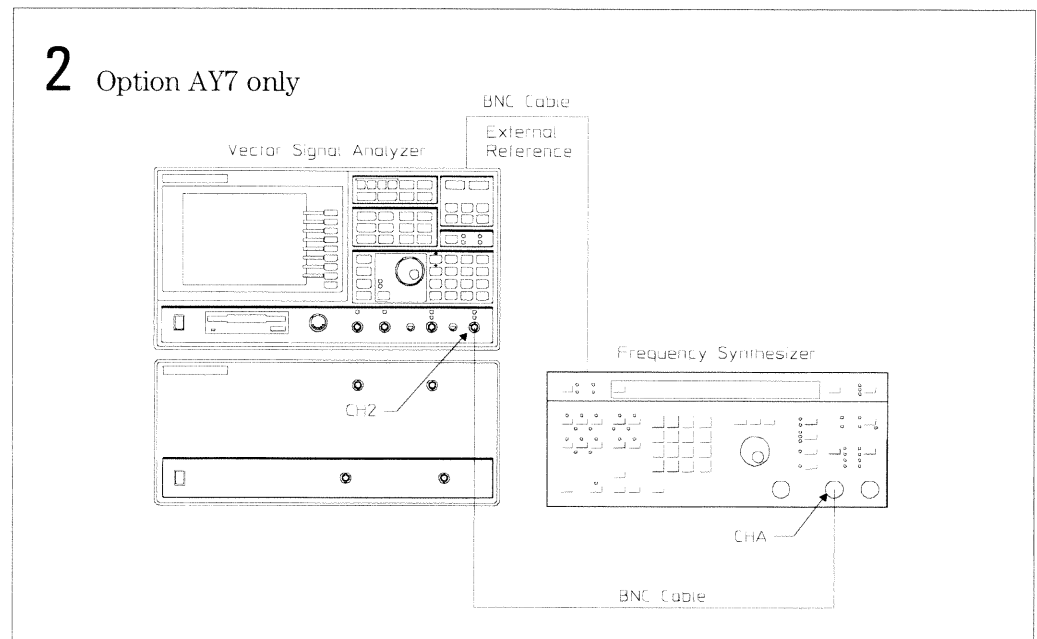

To set up the input trigger test

Performance Test and Operation Verification

This test verifies that the HP 89440A meets its baseband trigger specification for input channel trigger. In this test, a signal is connected to the HP 89440A. Trigger level and slope are then verified by reading the signal level and slope at 0 seconds in the time record.

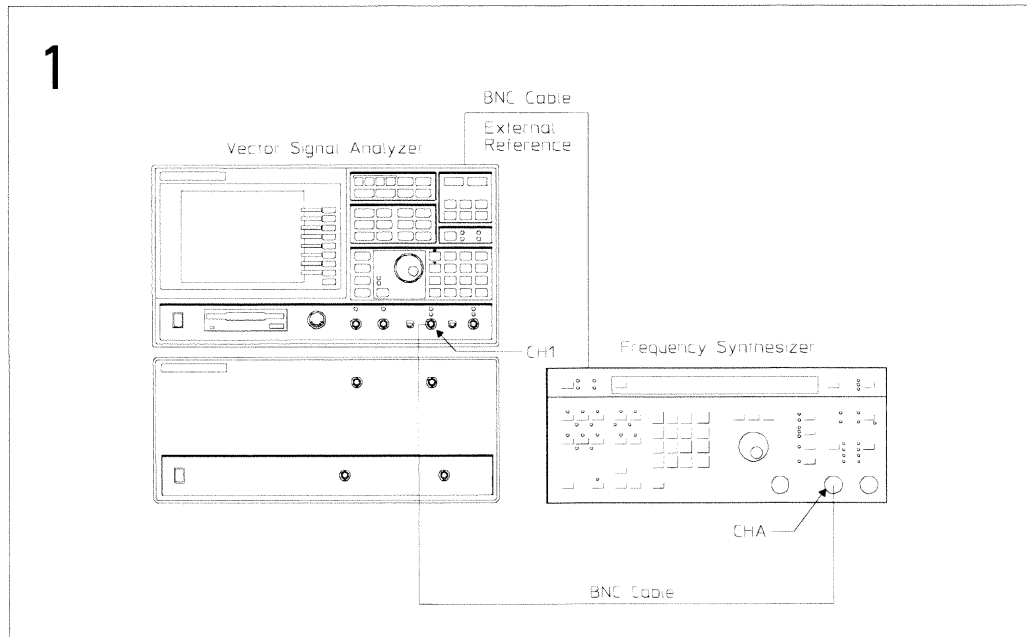

2 Option AY7 only

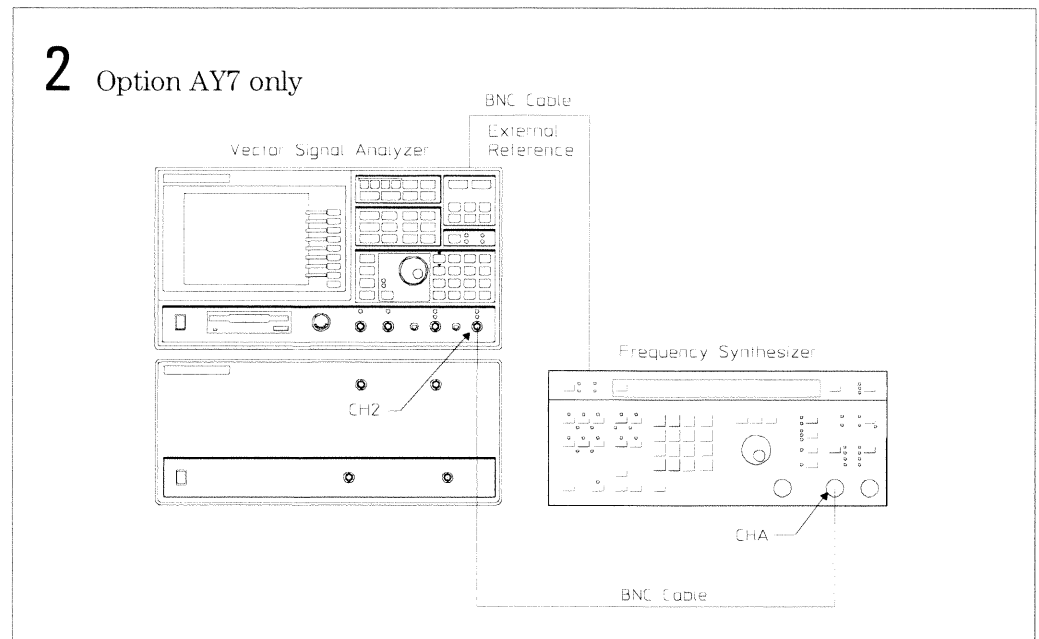

To set up the external trigger test

Performance Test and Operation Verification

This test verifies that the HP 89440A meets its baseband trigger specification for external trigger. In this test, a signal is connected to the external trigger input and channel 1. Trigger level and slope are then verified by reading the signal level and slope at 0 seconds in the time record.

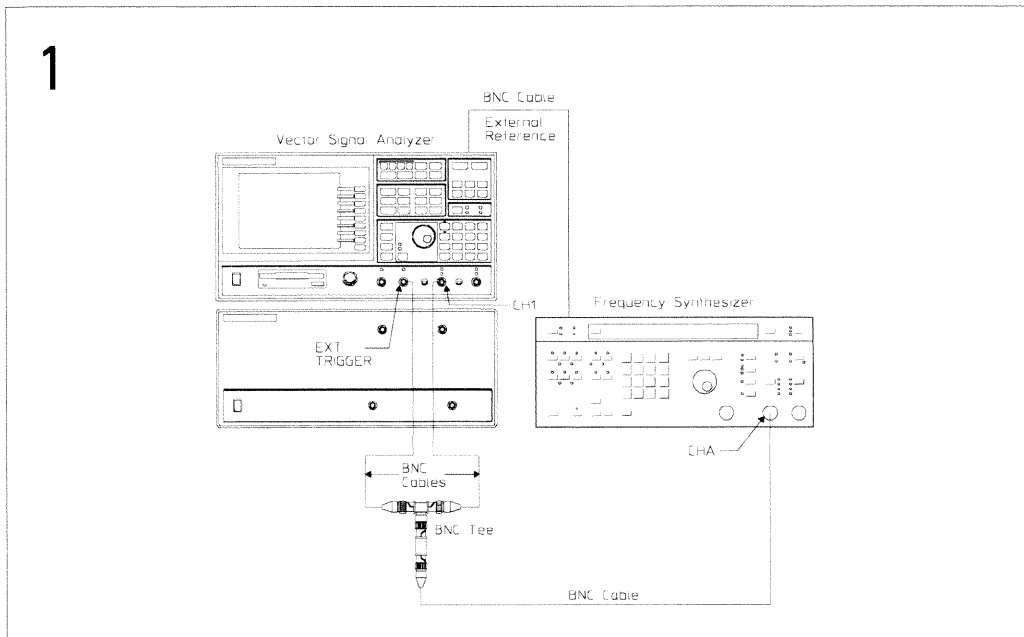

To set up the external arm test

Performance Test and Operation Verification

This test verifies that the HP 89440A meets its baseband trigger specification for external arm. In this test, a signal is connected to the external arm input. The signal level is increased until the instrument is armed.

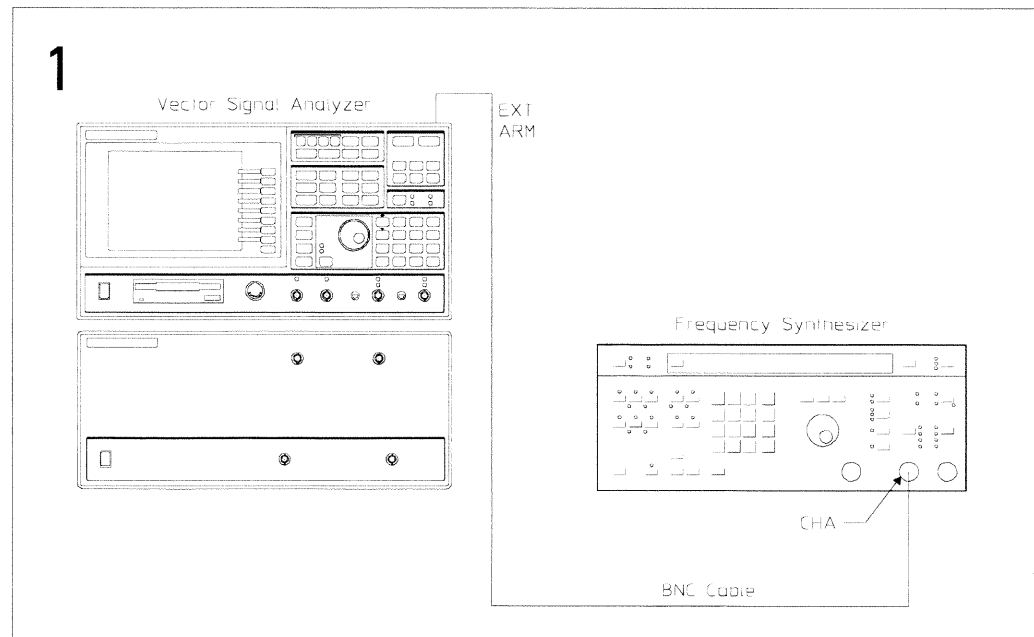

To set up the harmonic distortion test

Performance Test and Operation Verification

This test verifies that the HP 89440A meets its baseband dynamic range specification for harmonic distortion. In this test, a low pass filter attenuates the harmonics of a signal from the synthesizer. The analyzer measures the signal and the synthesizer level is adjusted for a full scale input (approximately 2 dBm). The analyzer then measures the second and third harmonics. If the harmonics fall outside the analyzer's frequency range, the analyzer measures the alias frequencies. The synthesizer is set to 9.75 MHz and 3.33 MHz.

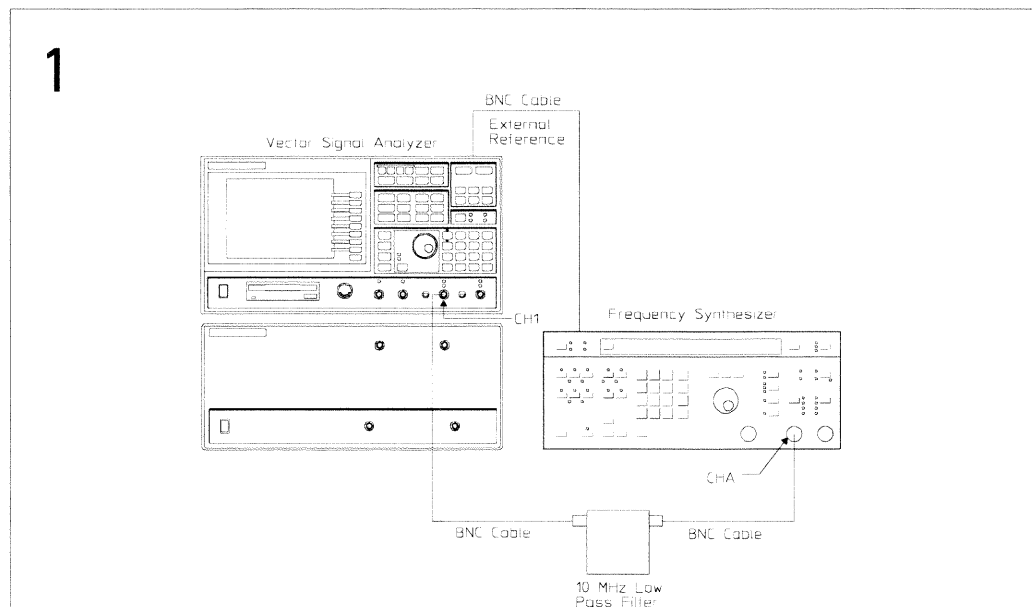

2 Option AY7 only

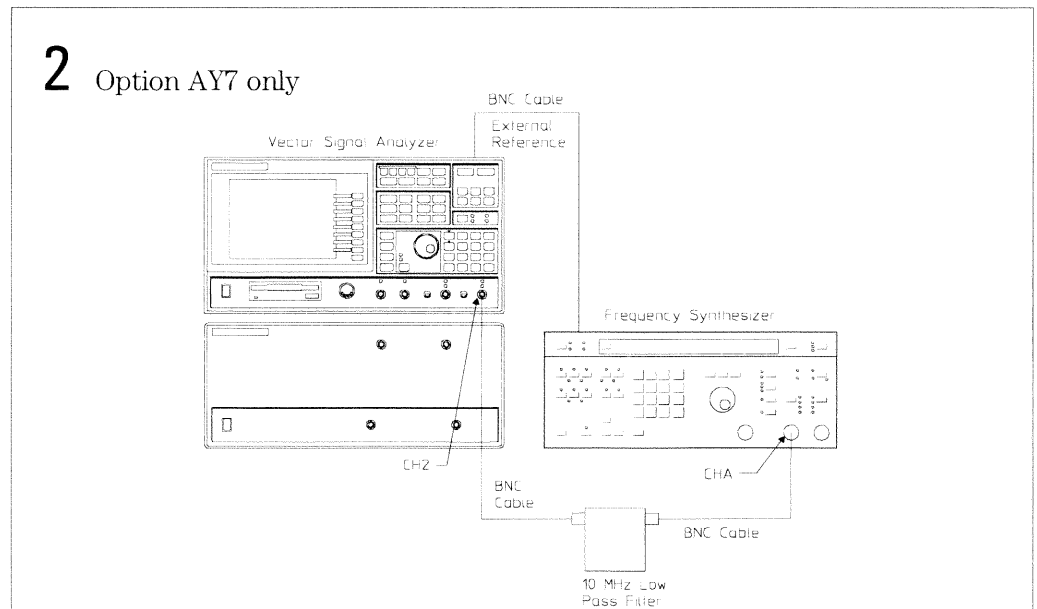

3

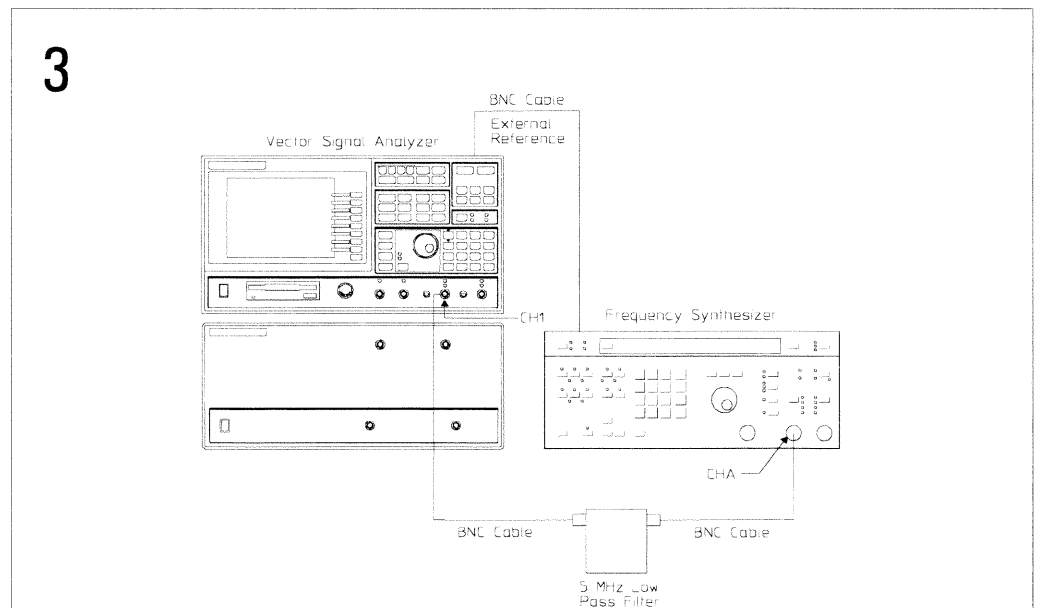

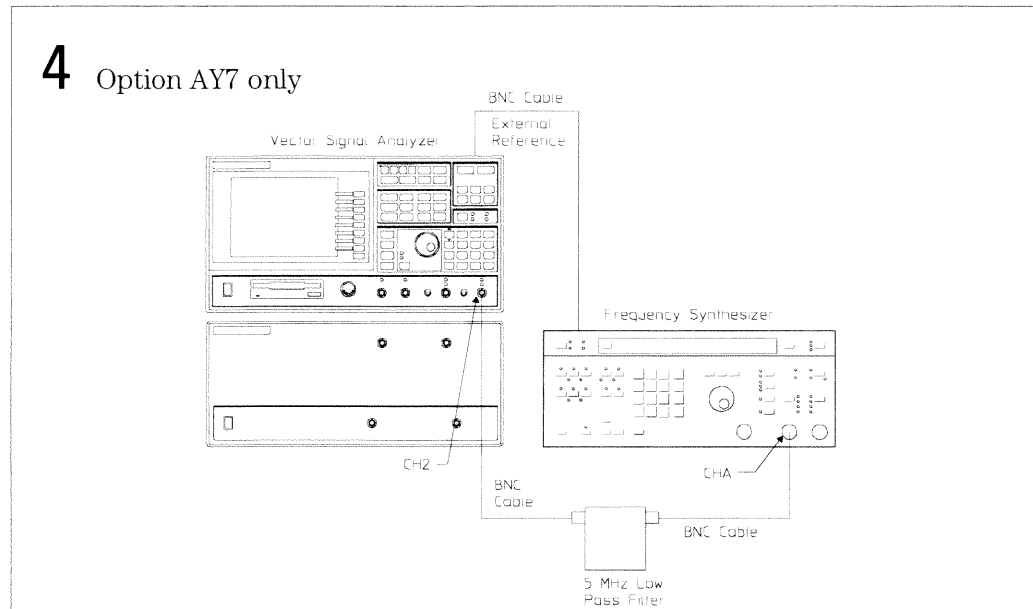

To set up the input capacitance test

Performance Test only

This test verifies that the HP 89440A meets its baseband input port specification for impedance. In this test, capacitance is measured using a frequency synthesizer and a 100 k Ω resistor. Capacitance is then calculated using the following formula:

$$C(pf) = C_factor \sqrt{v_{in}^2 / V_c^2 - 1.21} \times 1.0^{12}$$

Where $C_factor = 1.59^{-11}$ at 100 kHz

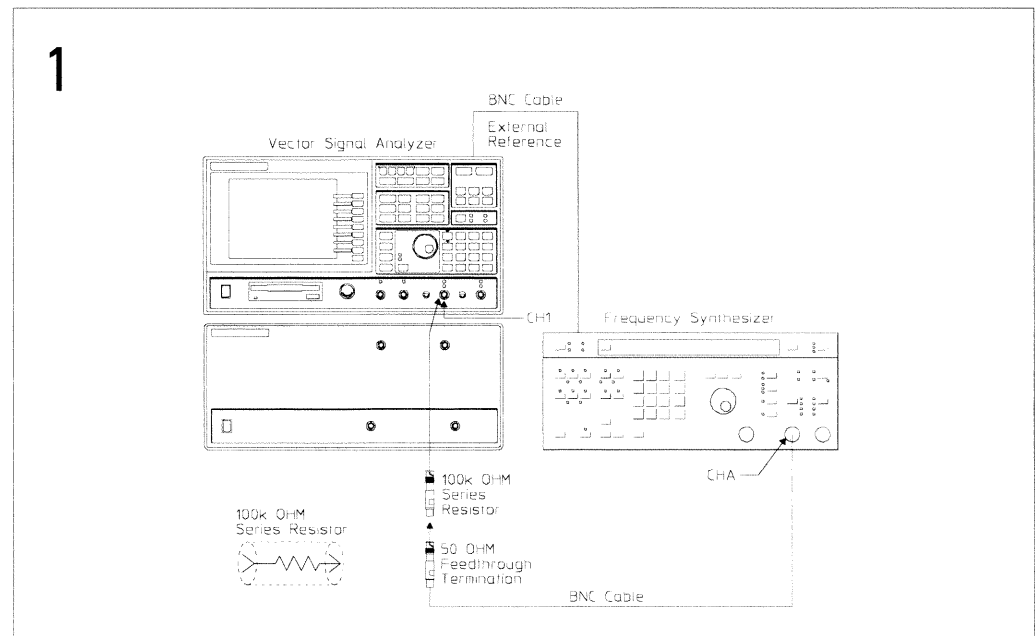

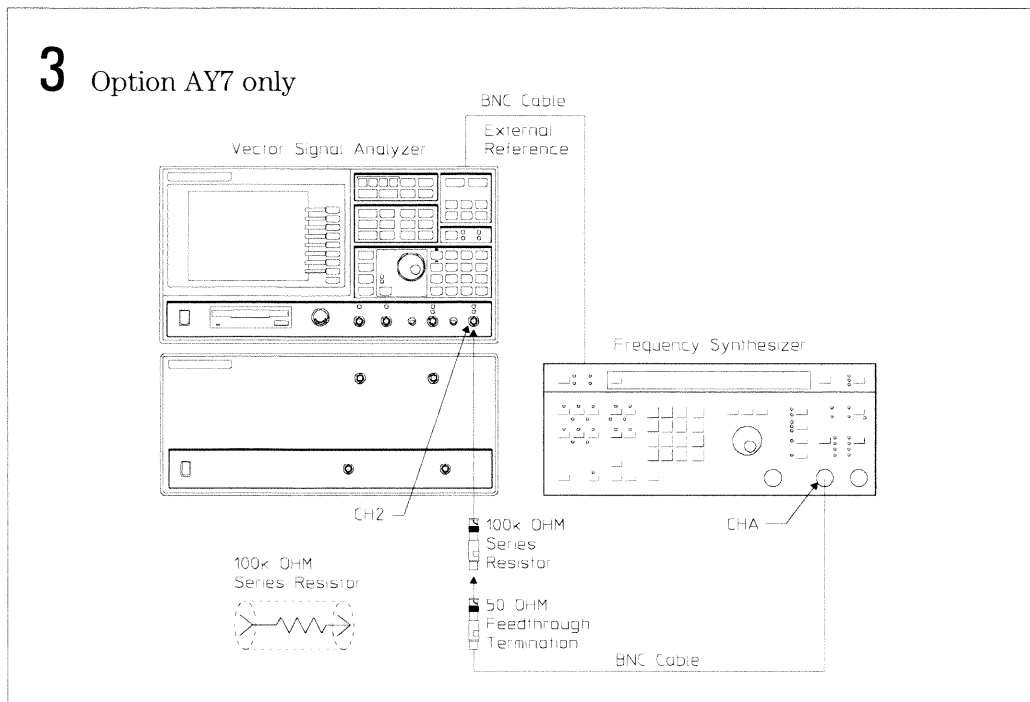
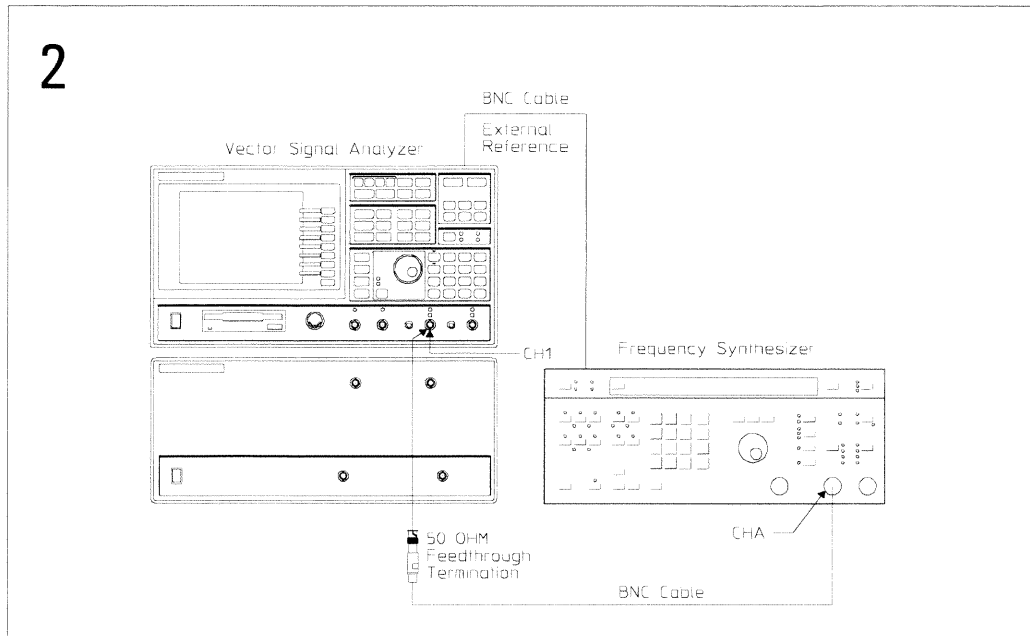

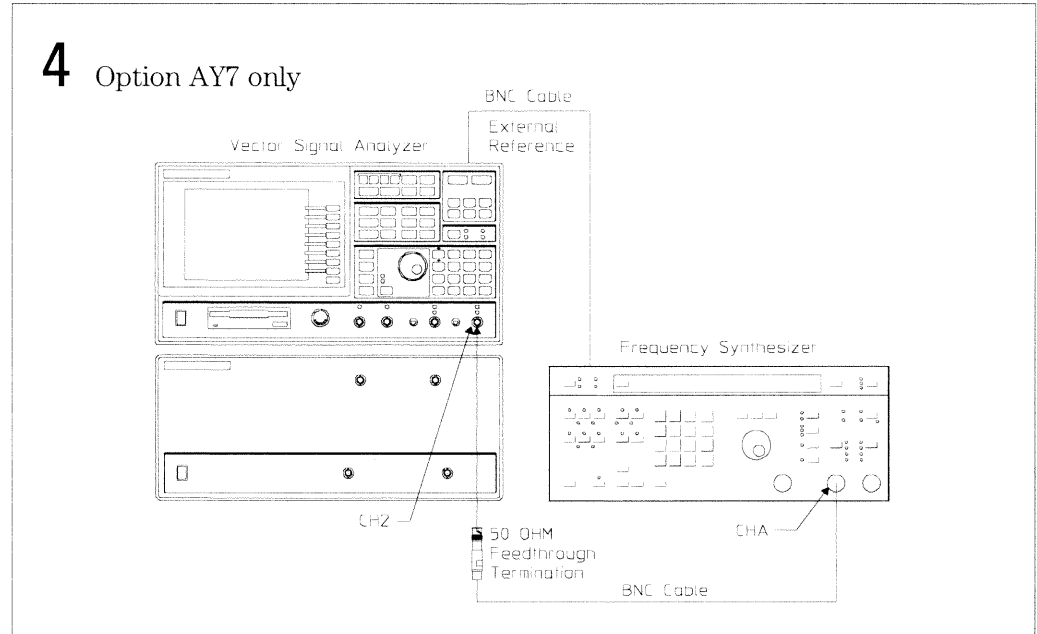

To set up the input resistance test

Performance Test only

This test verifies that the HP 89440A meets its baseband input port specification for impedance. In this test, input resistance is measured directly using a digital multimeter. The 10 M Ω range is used on the digital multimeter to prevent the current from turning on the overload protection FET in the input circuitry.

1

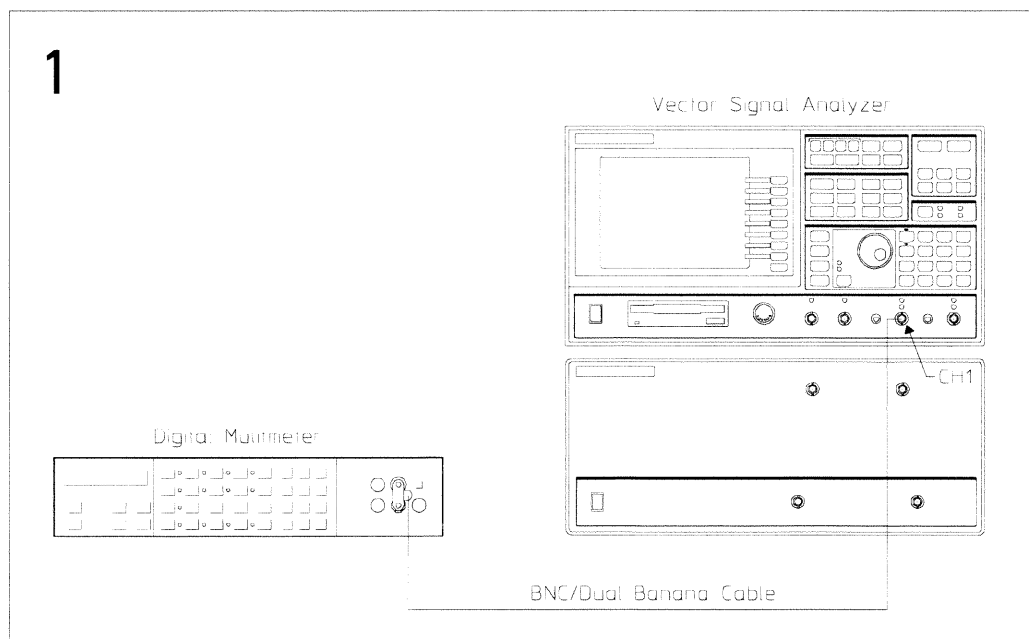

2 Option AY7 only

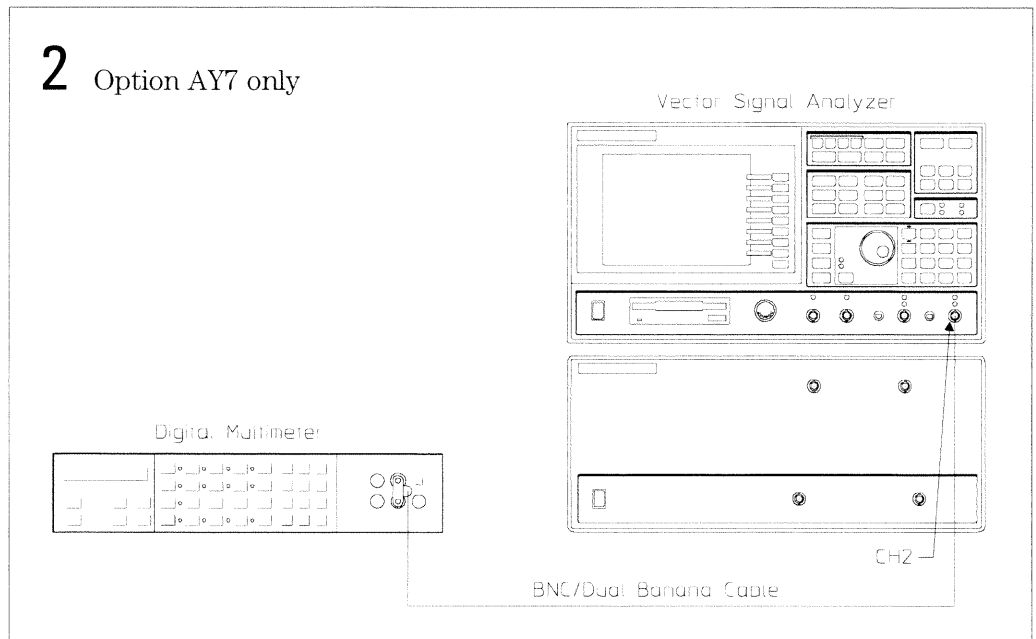

To set up the dc offset test

Performance Test and Operation Verification

This test verifies that the HP 89440A meets its baseband amplitude accuracy specification for residual dc. In this test, the HP 89440A measures its internal residual dc offset at six amplitudes with the filter in and out.

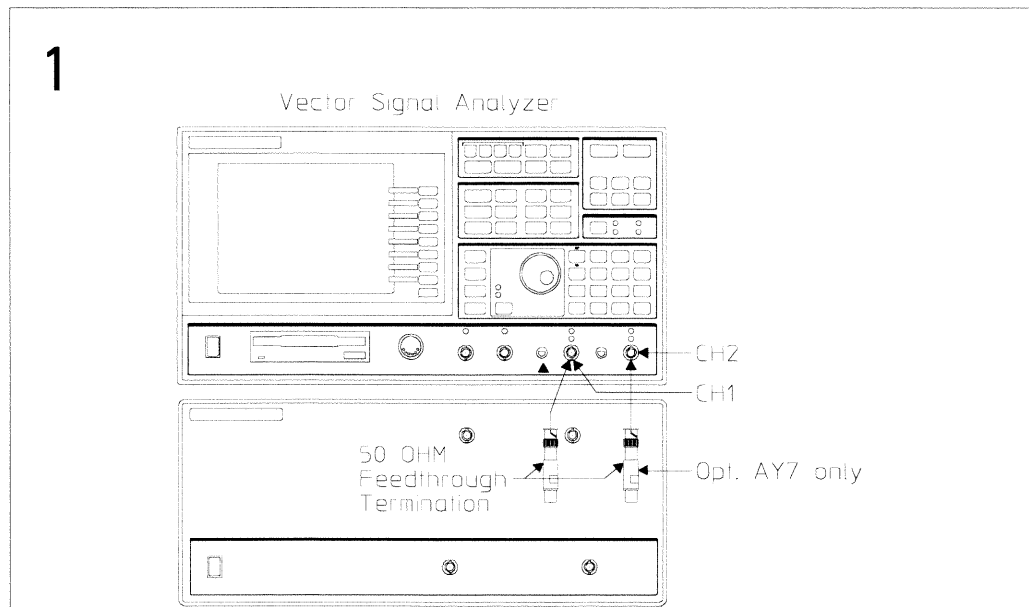

To set up the spurious signals test

Performance Test and Operation Verification

This test verifies that the HP 89440A meets its baseband dynamic range specification for residual (spurious) responses. In this test, the HP 89440A measures its internal spurious signals at six frequencies.

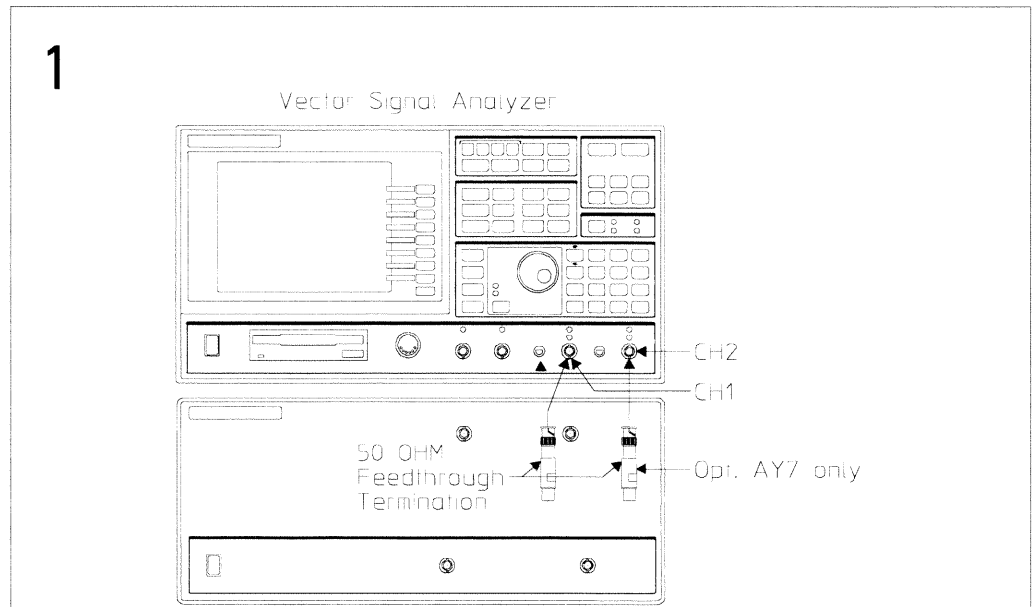

To set up the noise test

Performance Test and Operation Verification

This test verifies that the HP 89440A meets its baseband dynamic range specification for input noise density. In this test, the HP 89440A measures its internal noise from 1 kHz to 10 MHz.

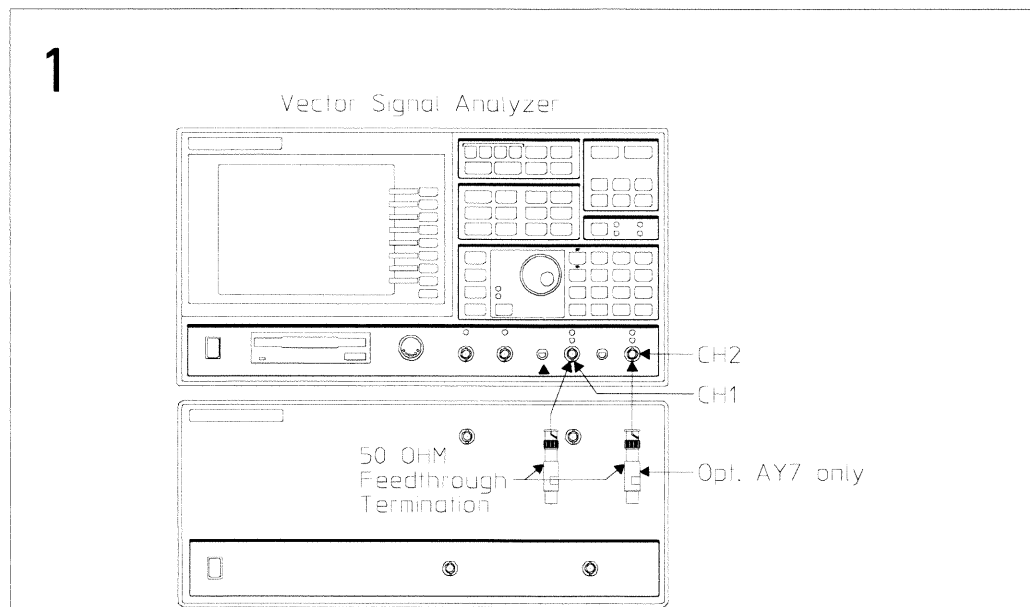

To set up the cross talk test

Performance Test only

This test verifies that the HP 89440A meets its baseband dynamic range specification for crosstalk. In this test, the HP 89440A measures the amount of energy induced from the source or input channel to another input channel. For source-to-receiver crosstalk, the analyzer's source is turned on and set for a high level output, then the signal level at the input is measured. For channel-to-channel crosstalk, a 9.9876 MHz, +20 dBm signal is connected to one channel and the signal level at the other input channel is measured.

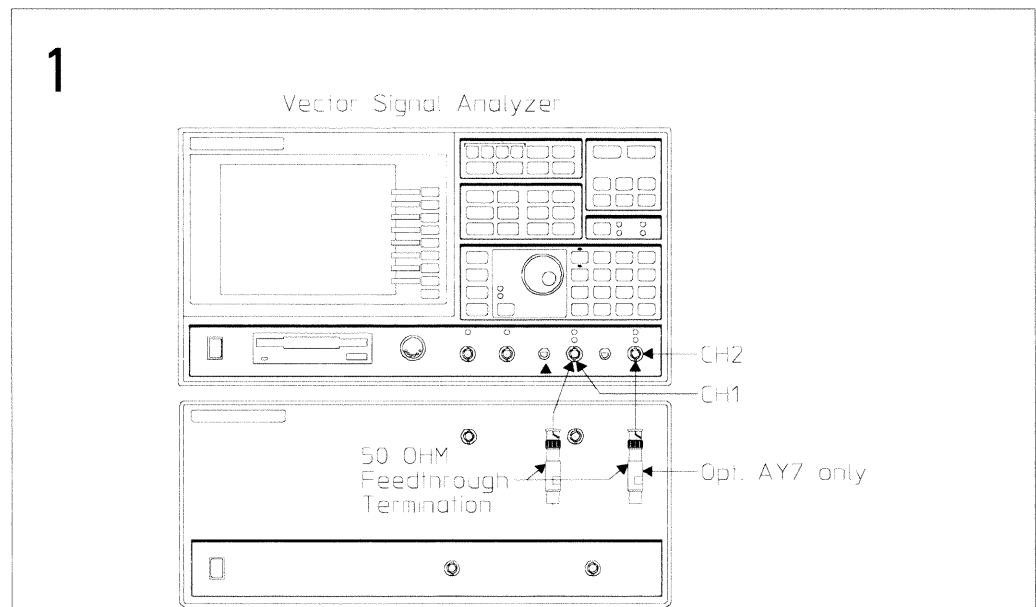

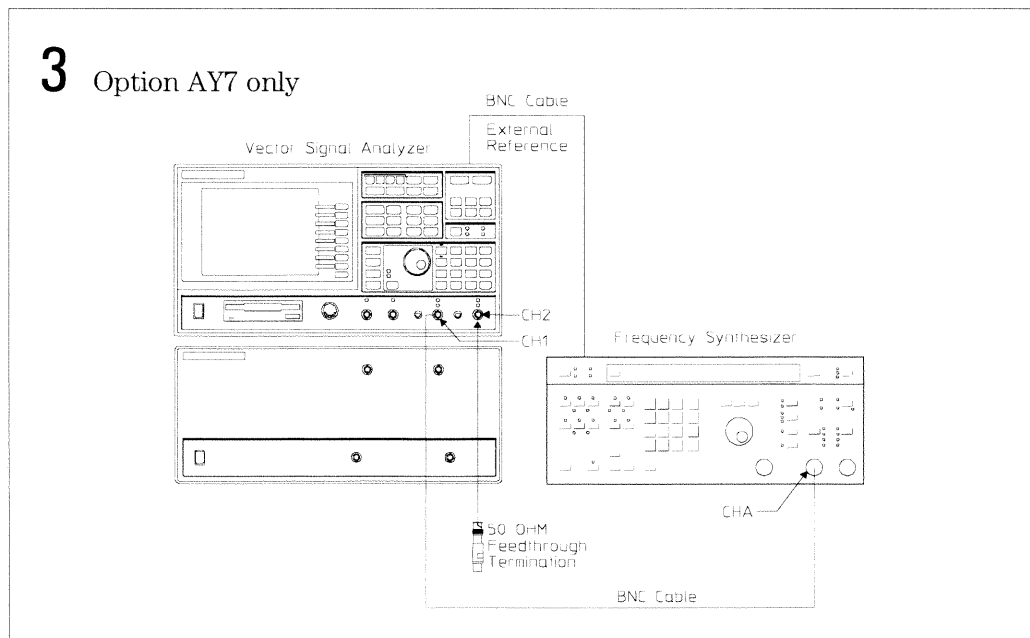
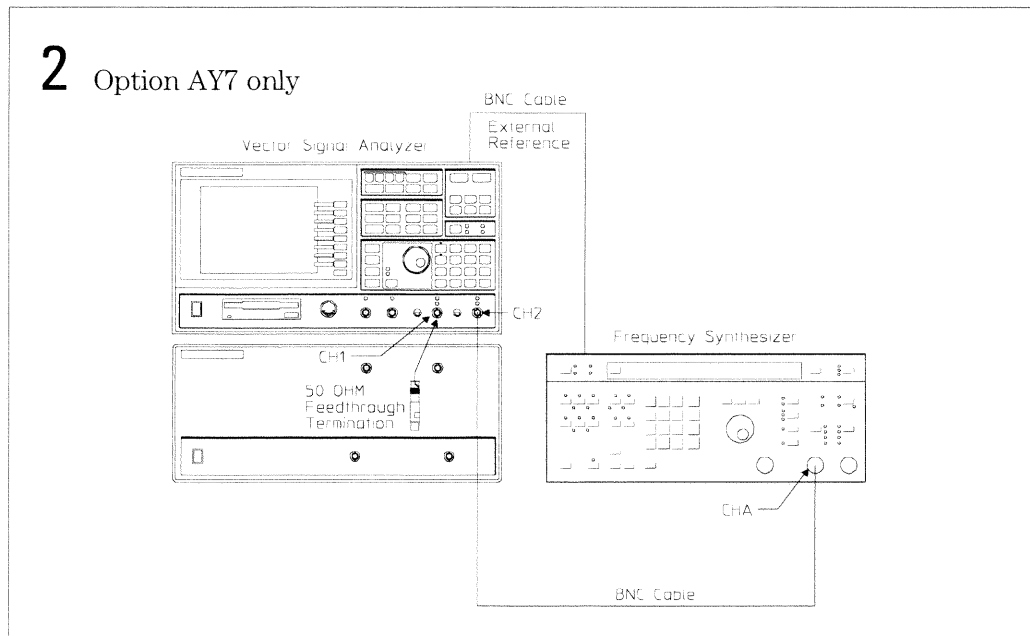

To set up the anti-alias filter test

Performance Test only

This test verifies that the HP 89440A meets its baseband dynamic range specification for alias responses. In this test, the HP 89440A measures the ability of the low pass anti-alias filter to reject frequencies caused by aliasing. Alias frequencies occur when the difference of the input signal frequency and the HP 89440A's sample rate both fall within the frequency range of interest. Using a synthesizer/level generator, a signal known to cause an alias frequency is connected to the HP 89440A. The HP 89440A then measures the alias frequency to determine how well the alias frequency was rejected. This test checks eight alias frequencies (the "Performance Test Record" at the end of this chapter lists the alias frequencies).

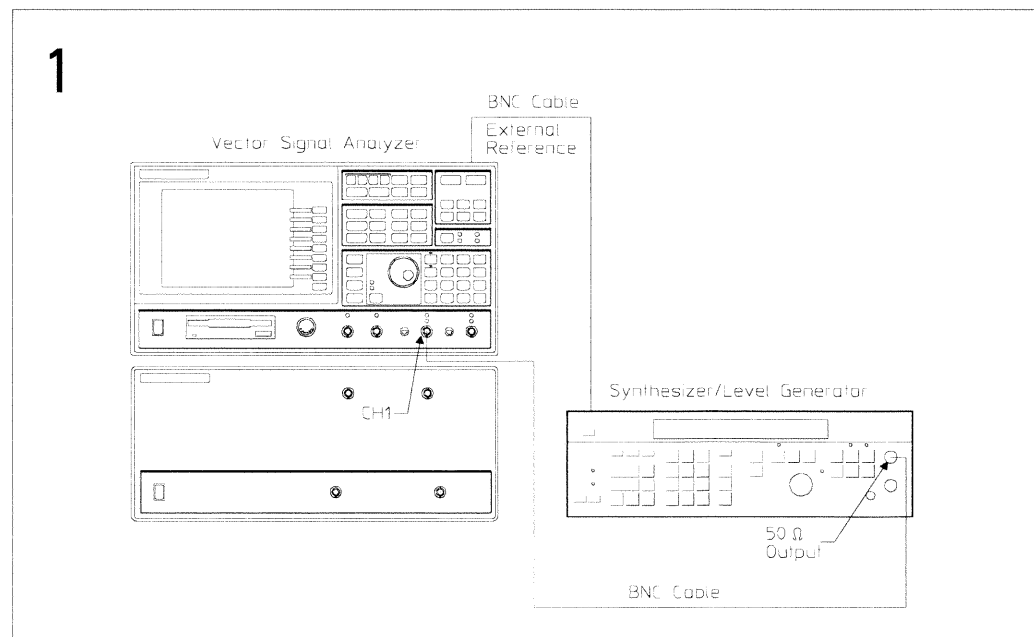

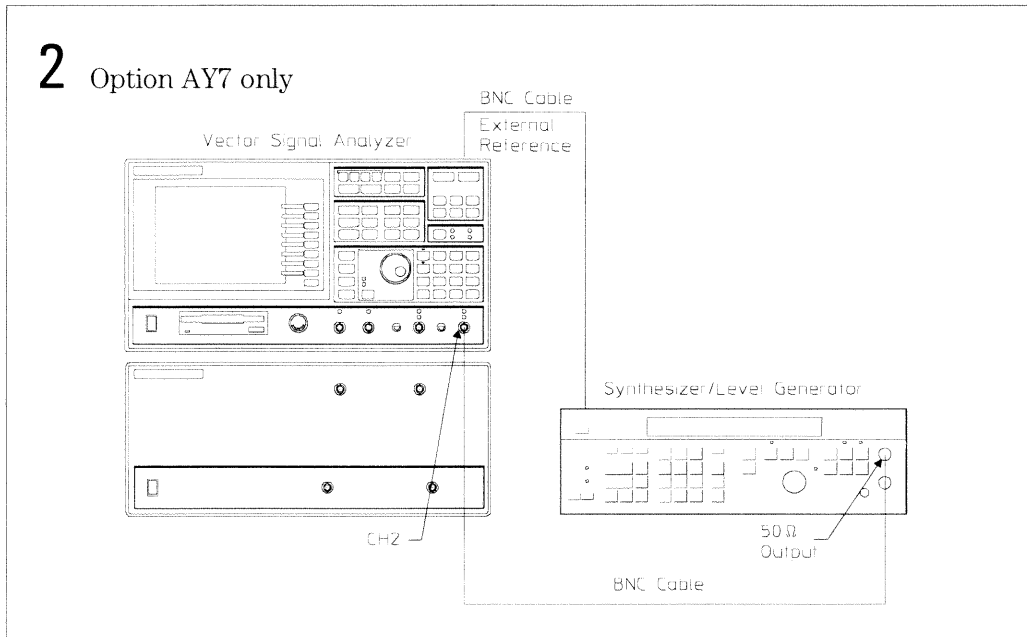

To set up the source amplitude accuracy test

Performance Test and Operation Verification

This test verifies that the HP 89440A meets its baseband source specification for amplitude accuracy. In this test, the synthesizer/level generator is connected to channel 1 and measurements are made at eleven amplitudes and eight frequencies (the “Performance Test Record” at the end of this chapter lists the amplitudes and frequencies). The HP 89440A’s source is then connected to channel 1 and the signal level is measured and compared to the level from the synthesizer/level generator.

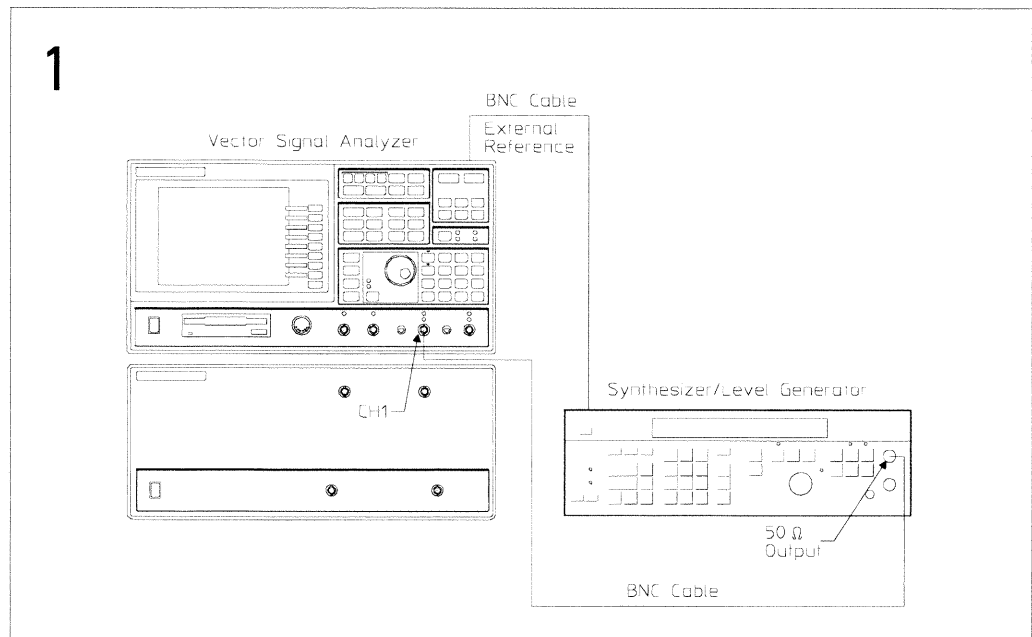

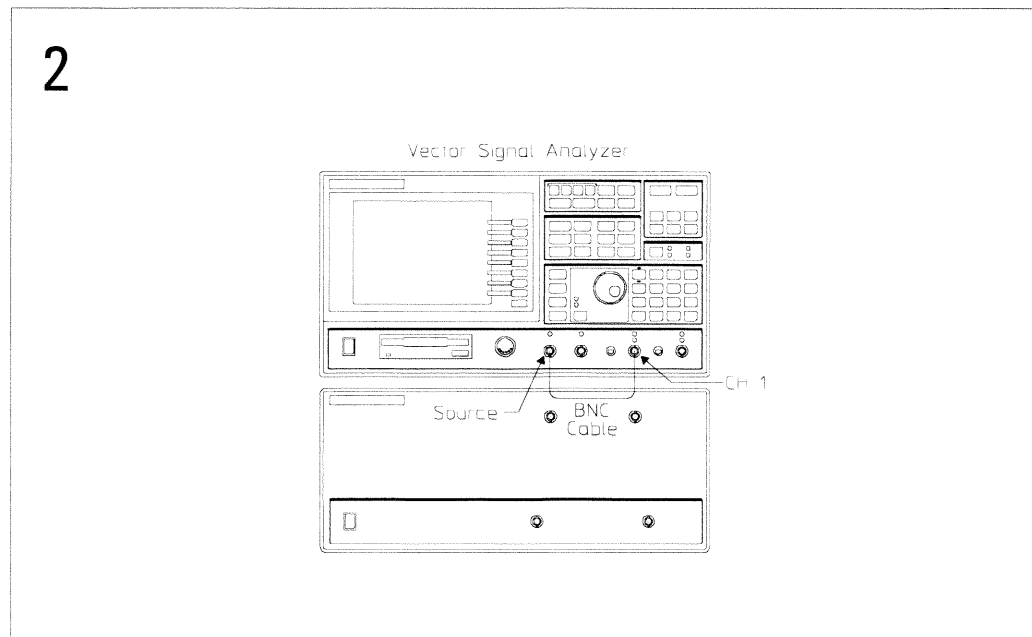

To set up the input rtn loss test

Performance Test only

This test verifies that the HP 89440A meets its baseband input port specification for return loss. In this test, a spectrum analyzer with a tracking generator is connected to a directional bridge. A reference measurement is made with the load port of the directional bridge open. The load port is then connected to an input channel and measurements are made for selected input range settings. This test measures both 50 and 75 Ω input impedances. The spectrum analyzer is set for a 100 kHz to 10 MHz frequency range.

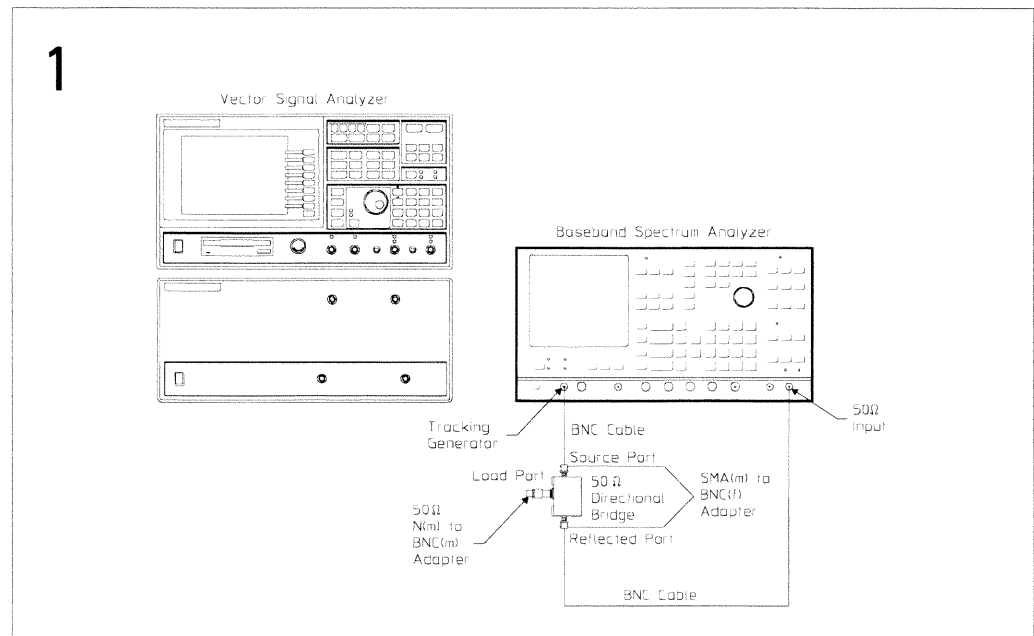

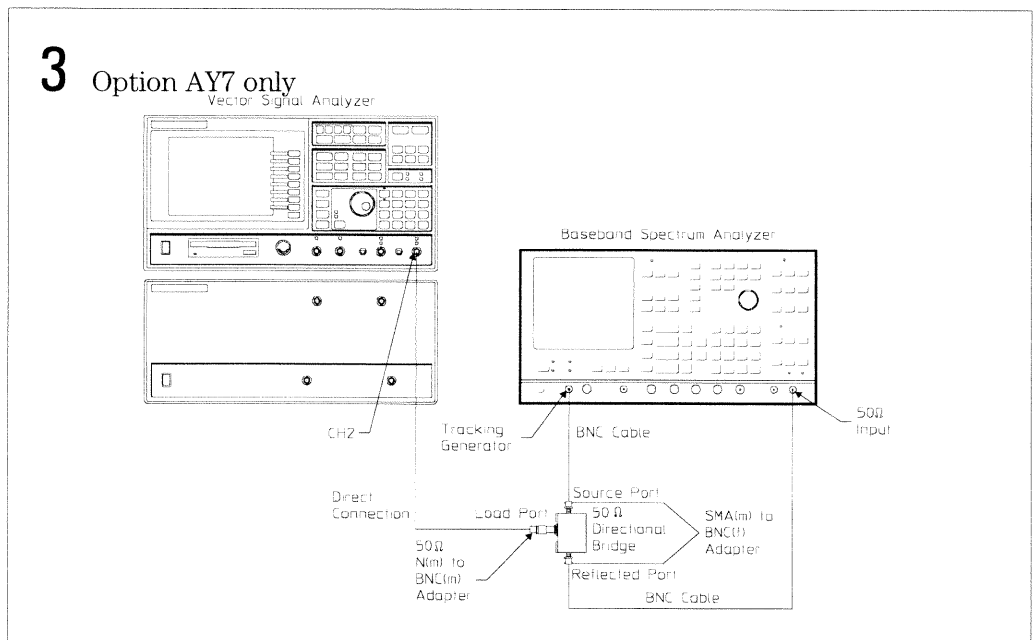
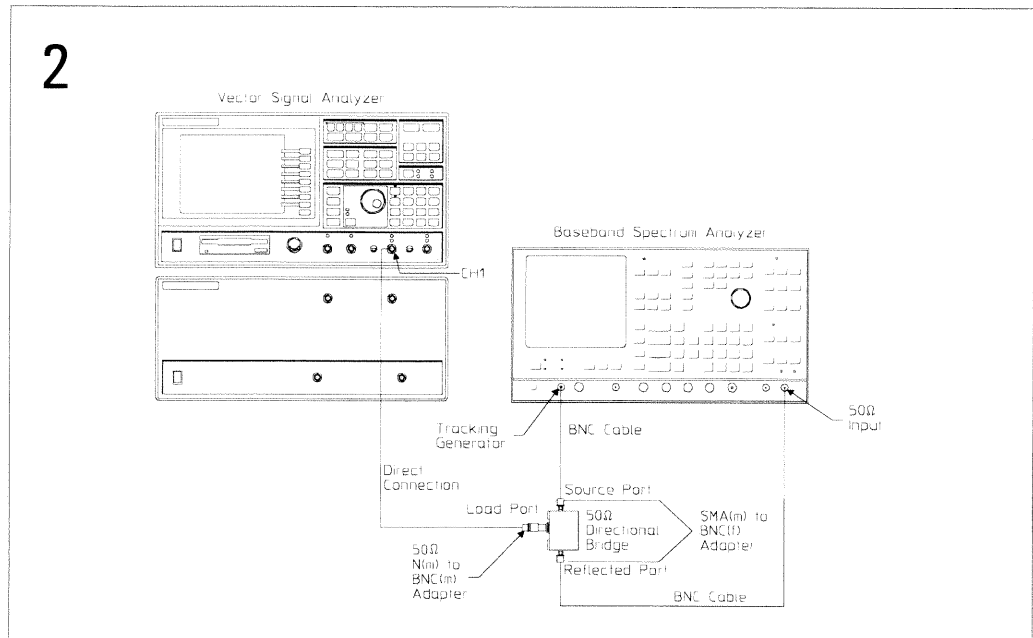

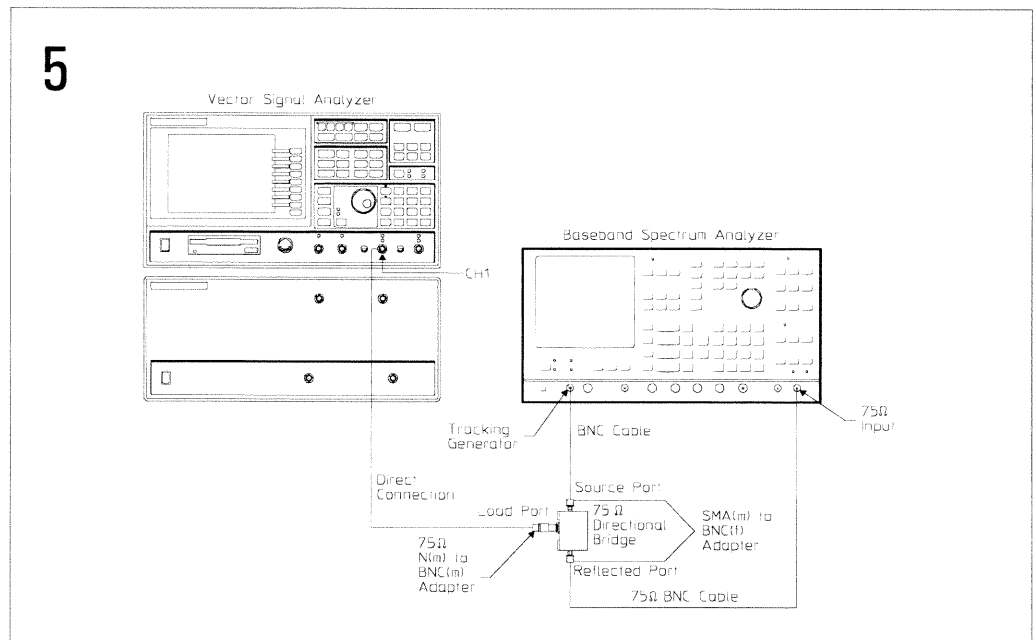
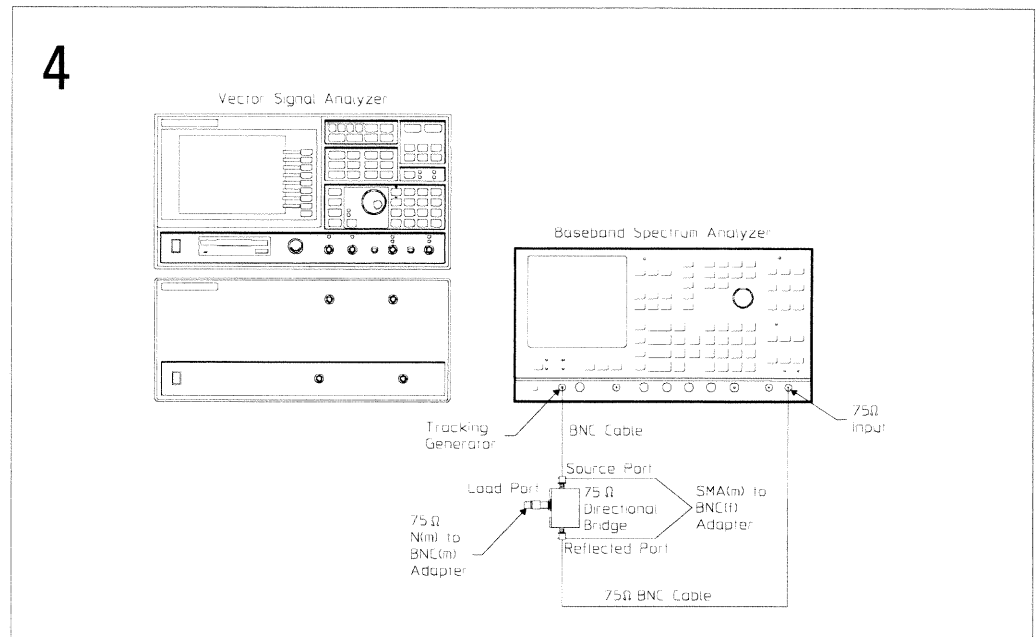

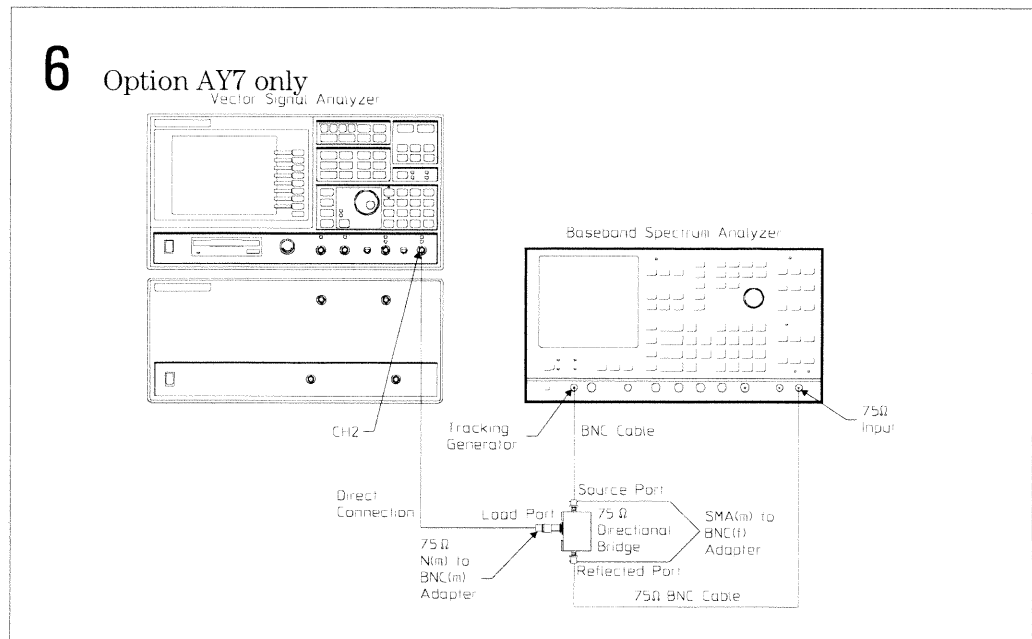

To set up the source rtn loss test

Performance Test only

This test verifies that the HP 89440A meets its baseband source port specification for return loss. In this test, a spectrum analyzer with a tracking generator is connected to a directional bridge. A reference measurement is made with the load port of the directional bridge open. The load port is then connected to the HP 89440A's source and measurements are made for selected attenuator settings. This test measures both 50 Ω and 75 Ω output impedances. The spectrum analyzer is set for a 100 kHz to 10 MHz frequency range.

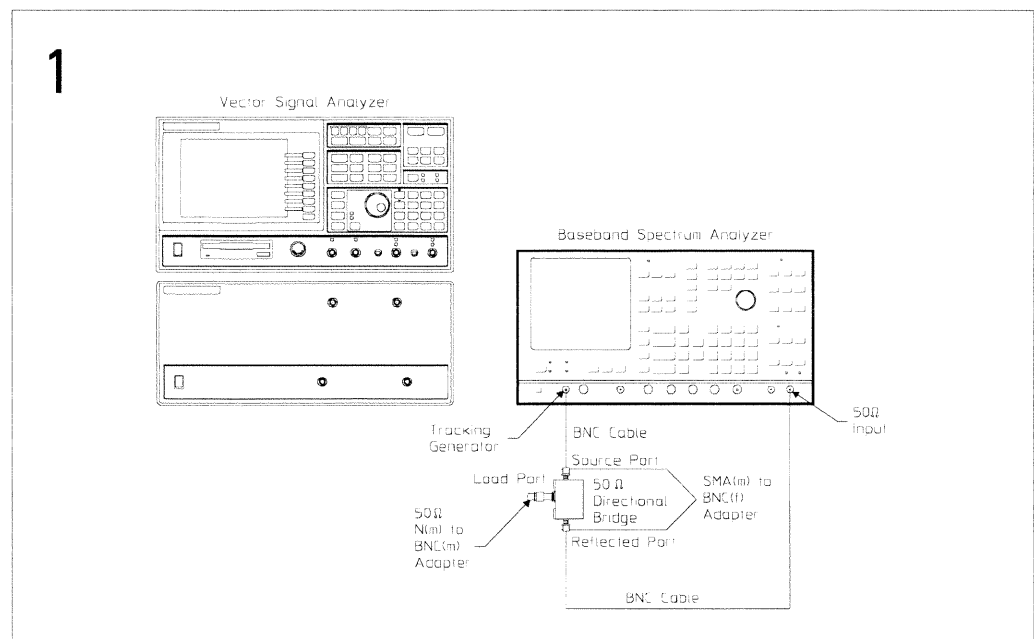

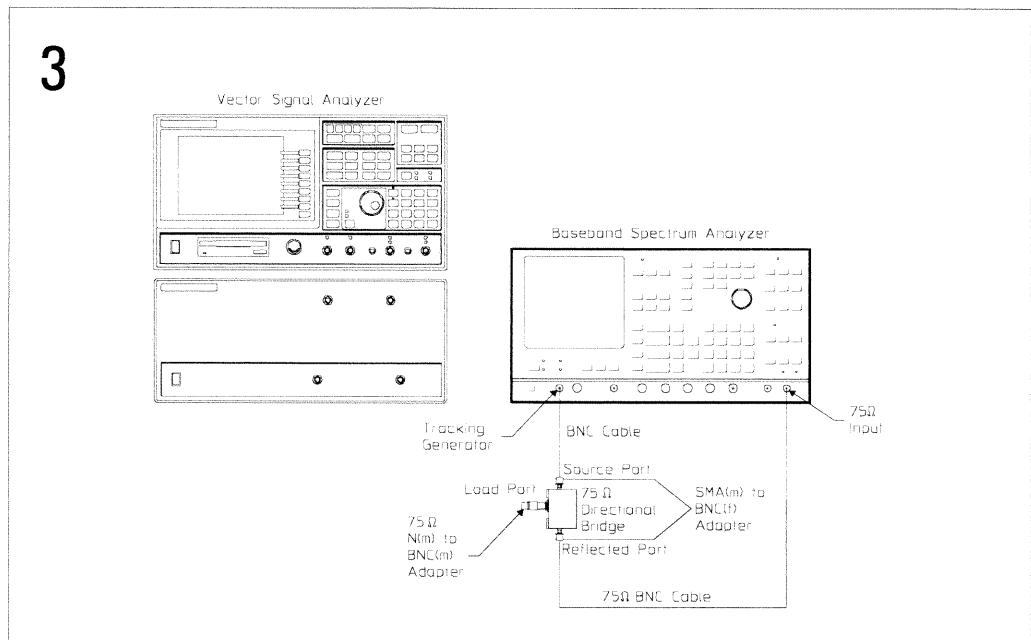
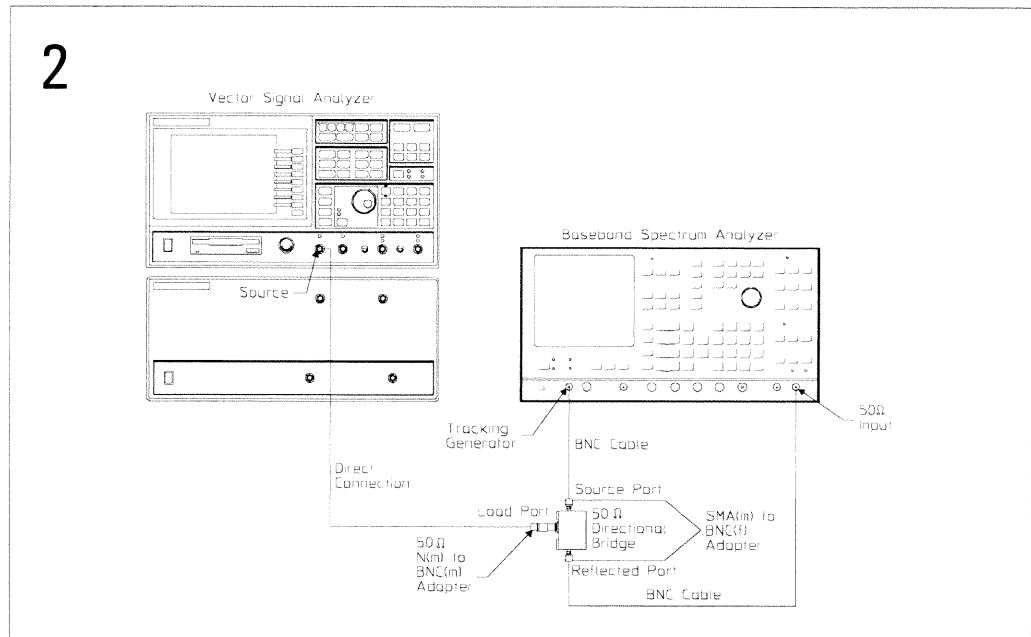

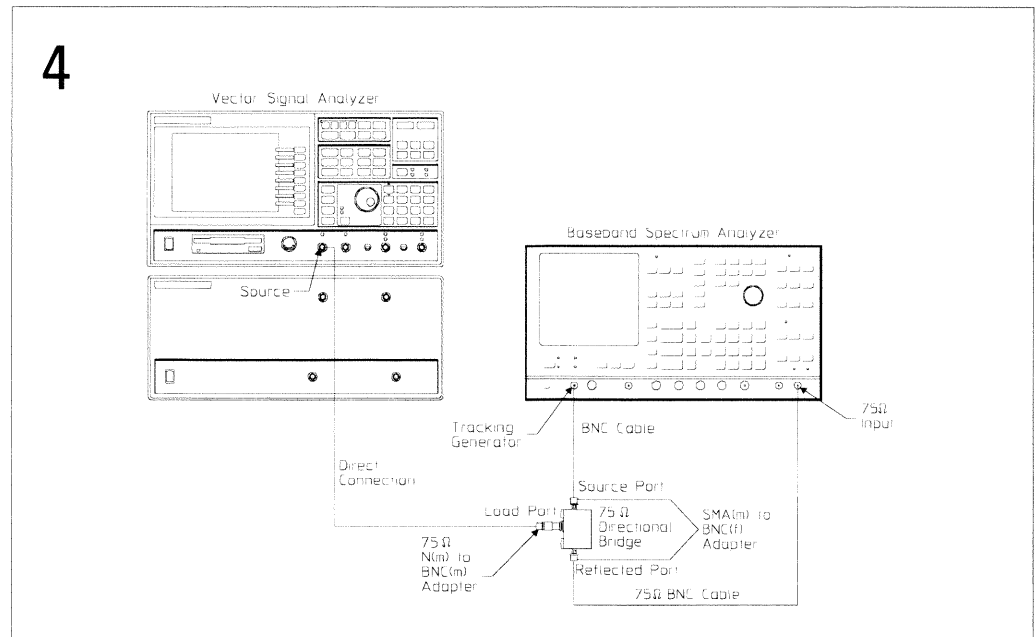

To set up the source distortion test

Performance Test and Operation Verification

This test verifies that the HP 89440A meets its baseband source specification for harmonic and other spurious products. In this test, a spectrum analyzer is connected to the HP 89440A's source. The source is set to five frequencies and two amplitudes (the "Performance Test Record" at the end of this chapter lists the frequencies and amplitudes) while the spectrum analyzer measures distortion and spurious responses from 100 Hz to 40 MHz.

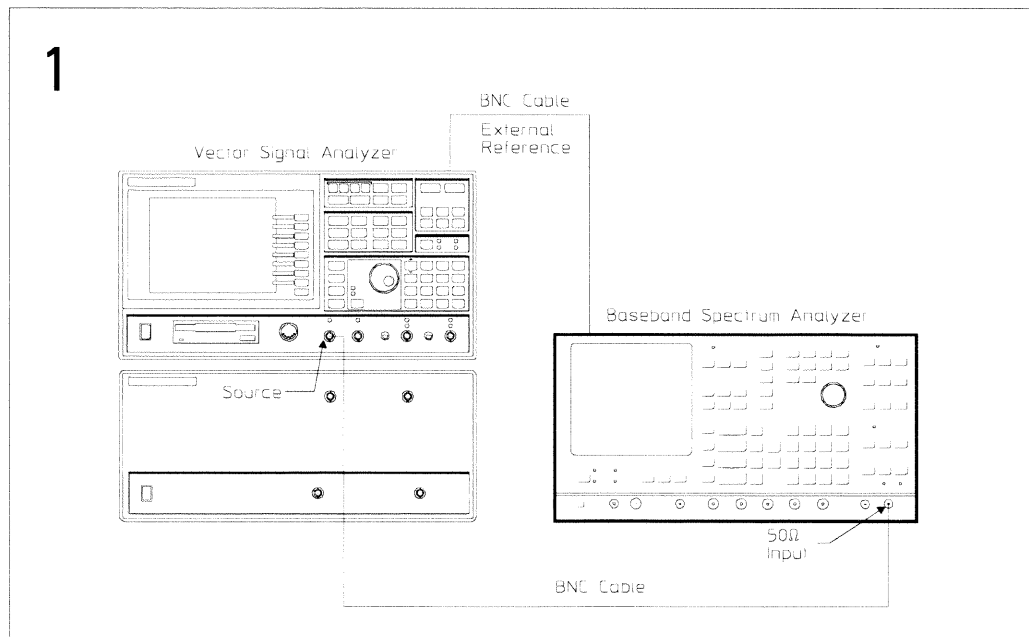

To set up the RF-amplitude accuracy test

Performance Test and Operation Verification

The temperature must be between 20° and 30° C to perform this test.

This test verifies that the HP 89440A meets its RF amplitude accuracy specification for absolute full scale accuracy. In this test, a signal generator outputs a signal to the power splitter. One output of the power splitter is measured by a power meter. The other output is measured by the analyzer. The two measurements are then compared. For each range tested (the “Performance Test Record” at the end of this chapter lists the ranges), the accuracy is measured at the center frequency of 38 different frequency settings between 2 MHz and 1800 MHz. The minimum and maximum frequency points are then tested at 7 frequency points offset from the worst case point.

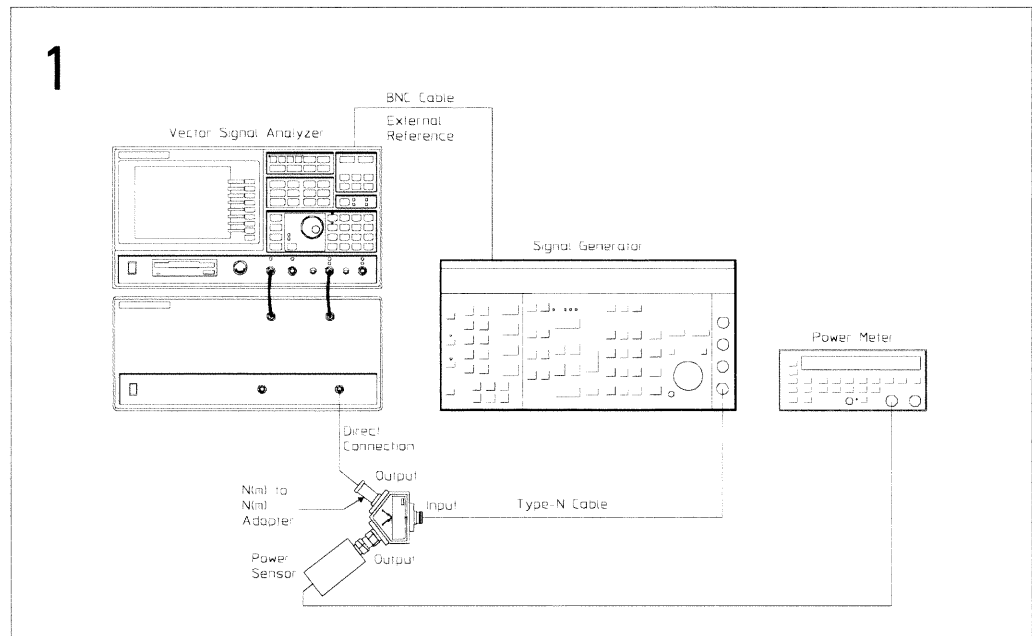

To set up the phase noise test

Performance Test and Operation Verification

This test verifies that the HP 89440A meets its RF frequency stability specification for phase noise. In this test, a signal generator supplies a clean 640 MHz, -20 dBm signal. The HP 89440A then measures phase noise at four offsets.

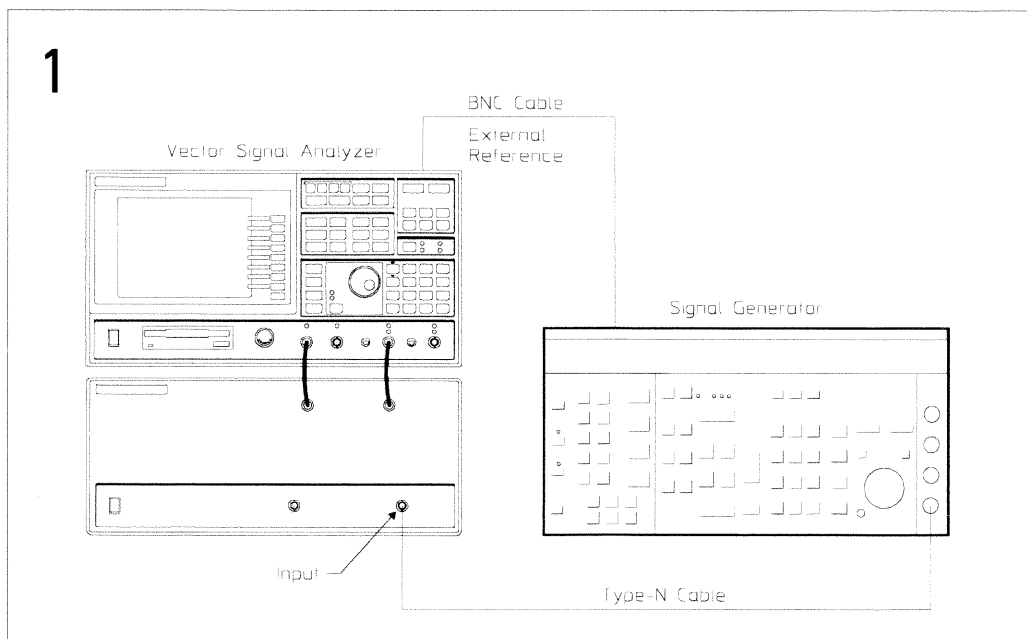

To set up the LO spurs test

Performance Test only

This test verifies that the HP 89440A meets its RF frequency stability specification for LO spurious sidebands. In this test, a signal generator supplies a clean 596 MHz, -20 dBm signal. The HP 89440A then measures the sidebands at six offsets.

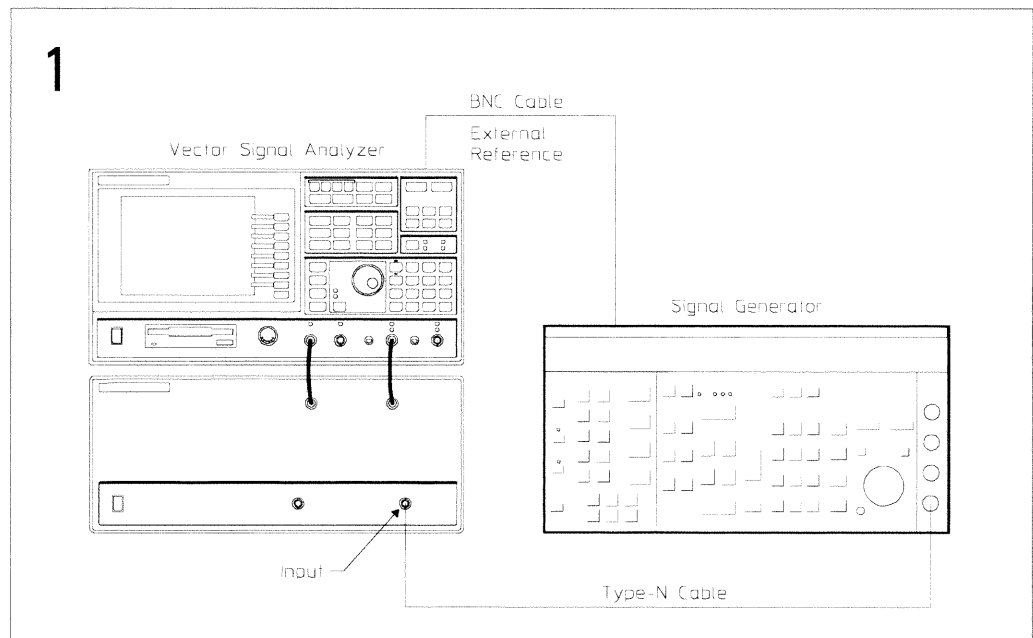

To set up the RF-spurious signals test

Performance Test and Operation Verification

This test verifies that the HP 89440A meets its RF dynamic range specification for general spurious. In this test, a signal generator supplies a clean -20 dBm signal. The HP 89440A then measures the spurious responses at various frequencies (the "Performance Test Record" at the end of this chapter lists the frequencies).

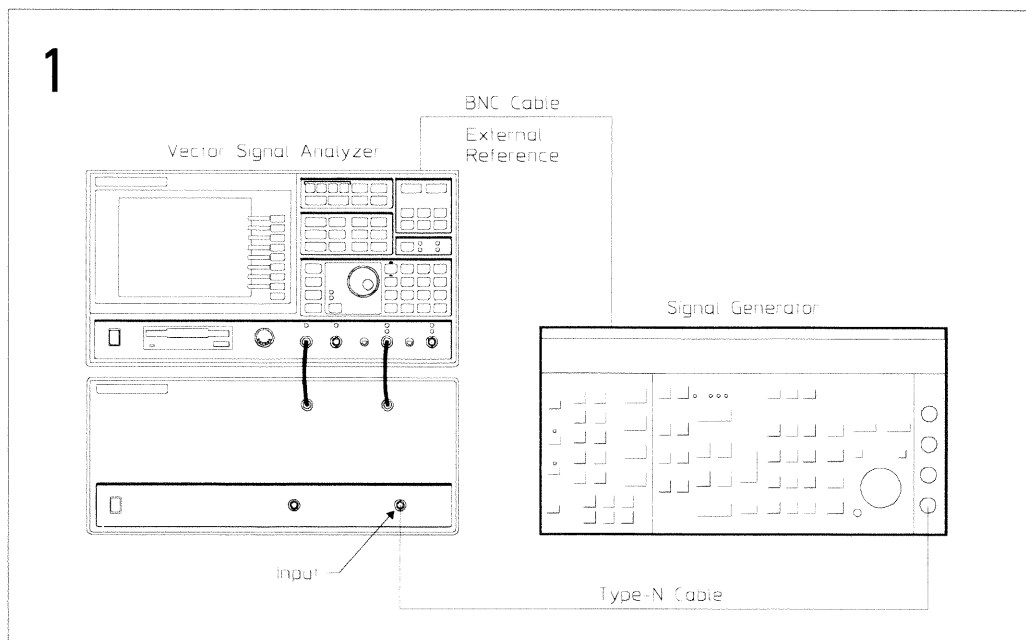

To set up the RF-harmonic distortion test

Performance Test and Operation Verification

This test verifies that the HP 89440A meets its RF dynamic range specification for harmonic distortion. In this test, a low pass filter attenuates the harmonics of a -20 dBm signal from the signal generator. The analyzer measures the signal and the signal generator level is adjusted for a full scale input. The analyzer then measures the second through fifth harmonics (the "Performance Test Record" at the end of this chapter lists the frequencies and harmonics).

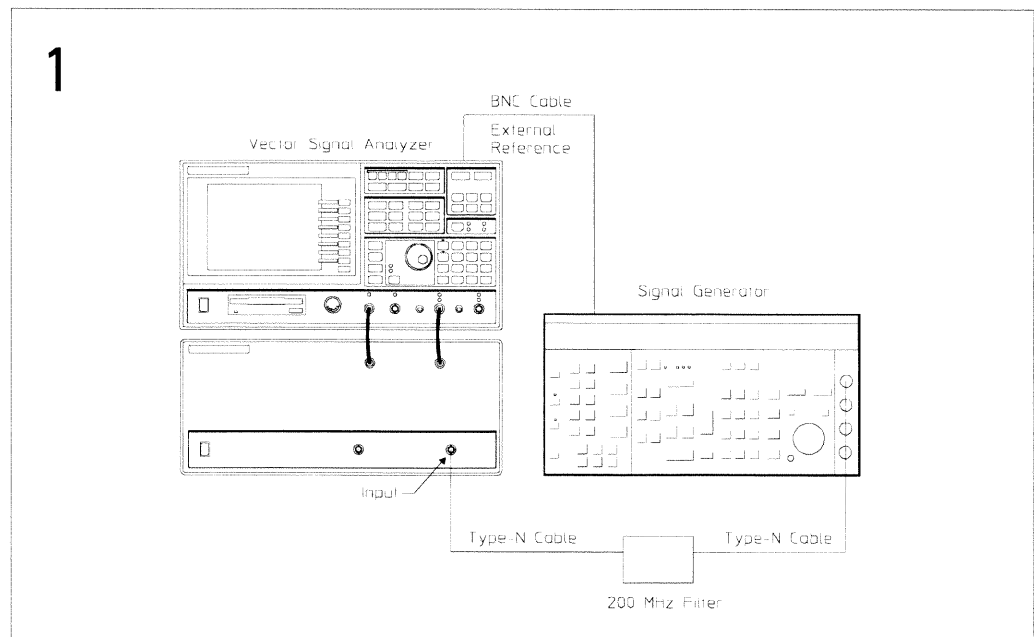

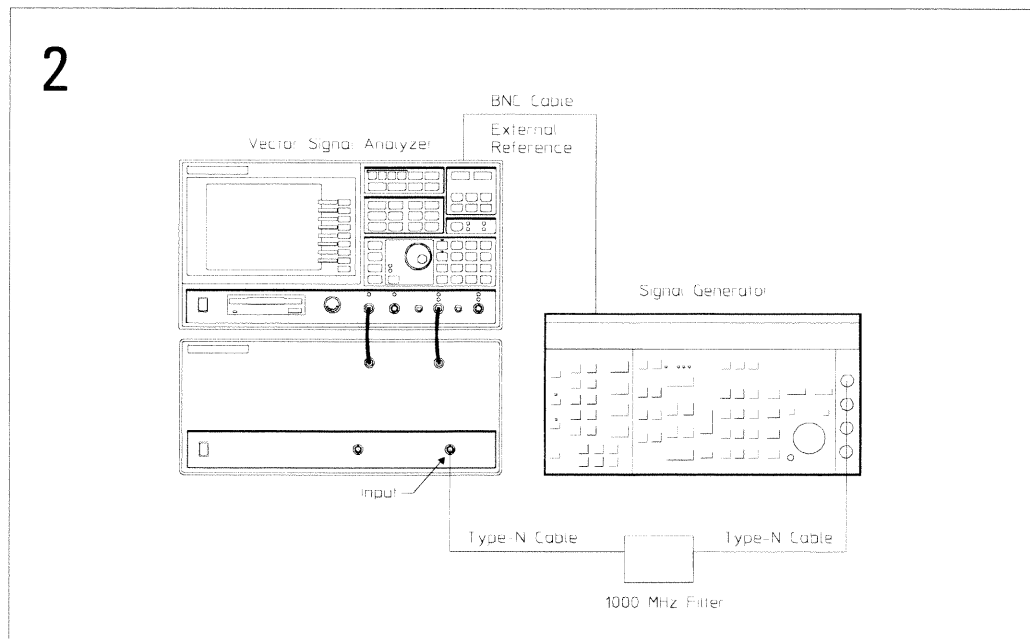

To set up the frequency accuracy test

Performance Test and Operation Verification

The HP 89440A must be on for 30 minutes before performing this test.

This test verifies that the HP 89440A meets its baseband frequency accuracy specification. In this test, the analyzer measures the frequency of an accurate 1500 MHz signal. The frequency limits are then calculated using the number of months since the last frequency reference adjustment.

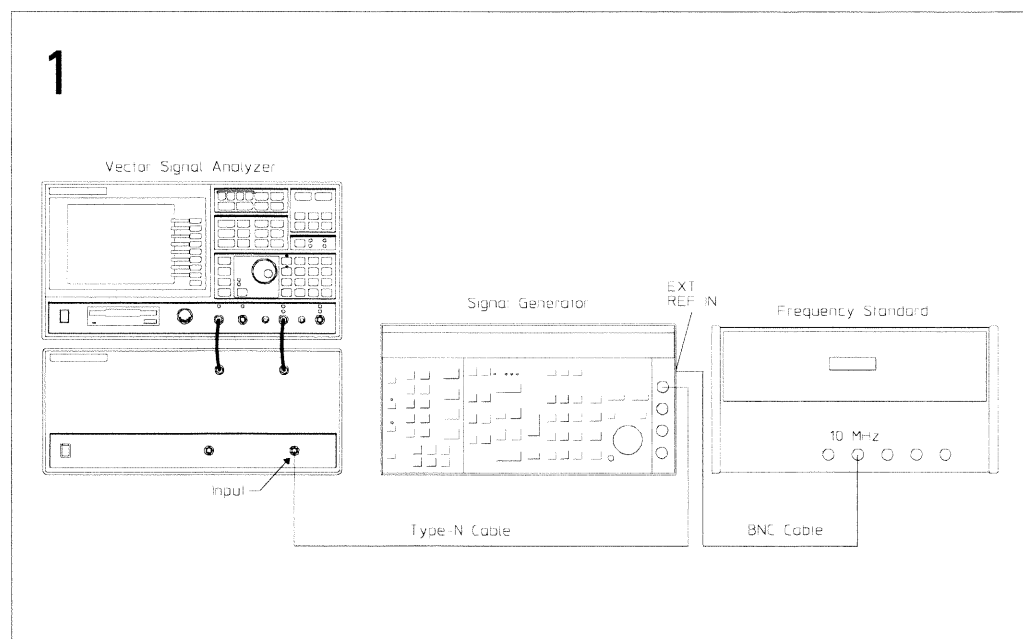

To set up the RF-noise test

Performance Test and Operation Verification

The temperature must be between 20° and 30° C to perform this test.

This test verifies that the HP 89440A meets its RF dynamic range specification for noise level. In this test, the HP 89440A measures its internal noise at 7 frequencies.

1

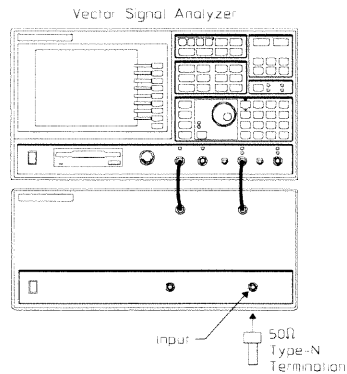

To set up the RF-source amplitude accuracy test

Performance Test and Operation Verification

This test is only for HP 89440A's with the optional RF source (option AY8). This test verifies that the HP 89440A meets its RF source specification for absolute accuracy at 6 MHz. In this test, a power meter sensor is connected to the RF source. The power meter measures the RF source's absolute accuracy at 6 MHz, 5 dBm and flatness from 6 MHz to 1800 MHz at 13 dBm.

1 Option AY8 only

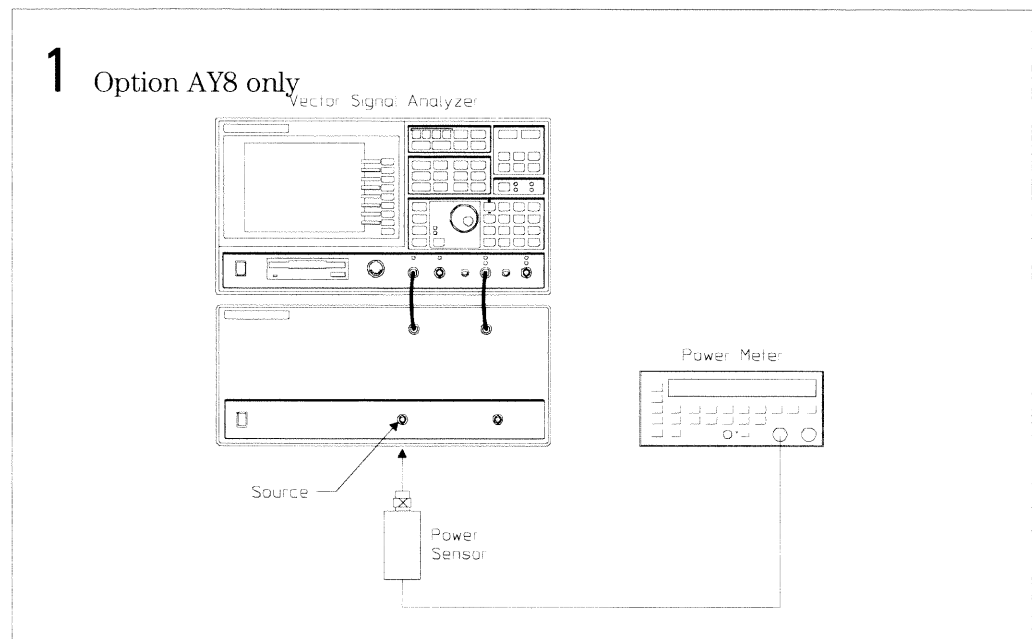

To set up the RF-source IF-flatness test

Performance Test and Operation Verification

This test is only for HP 89440A's with the optional RF source (option AY8). This test verifies that the HP 89440A meets its RF source specifications for IF flatness. In this test, a power meter sensor is connected to the RF source. The power meter then measures the IF flatness from 897.5 MHz to 904.5 MHz.

1 Option AY8 only

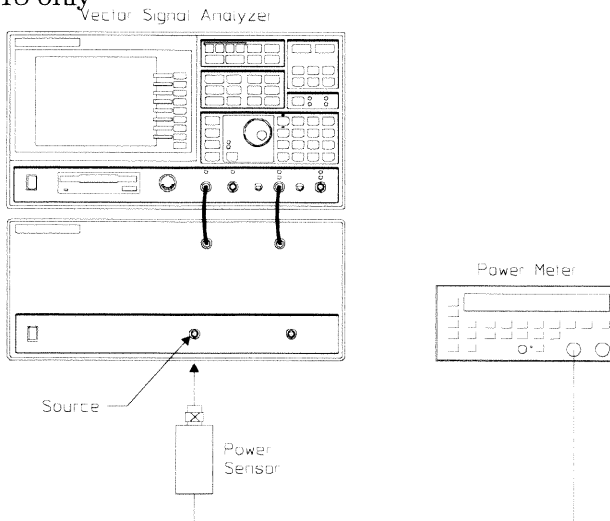

To set up the RF-source distortion test

Performance Test and Operation Verification

This test is only for HP 89440A's with the optional RF source (option AY8). This test verifies that the HP 89440A meets its RF source specification for harmonic distortion. In this test, a spectrum analyzer measures the RF source's 2nd, 3rd, 4th, and 5th harmonics (the "Performance Test Record" at the end of this chapter lists the frequencies and harmonics).

1 Option AY8 only

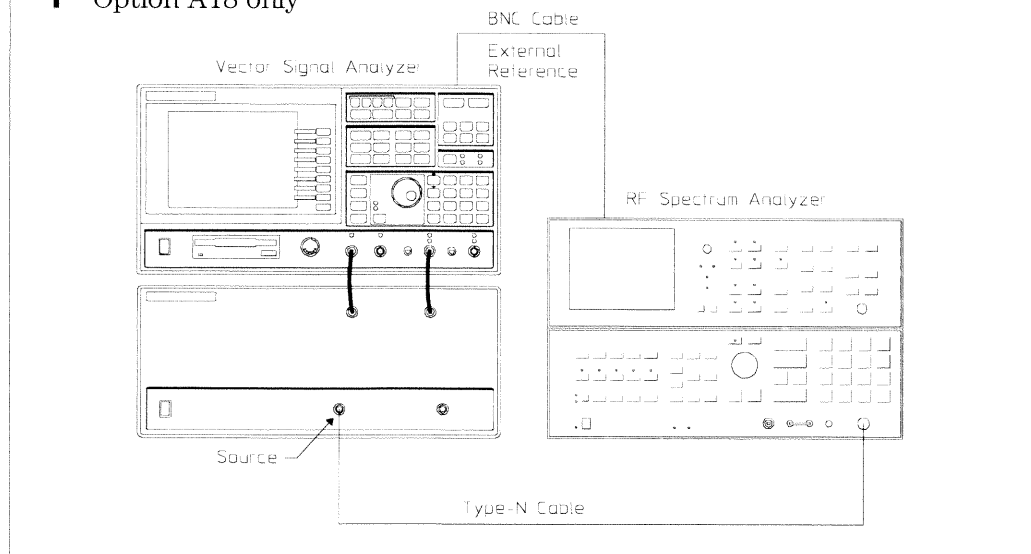

To set up the RF-source noise test

Performance Test and Operation Verification

This test is only for HP 89440A's with the optional RF source (option AY8). This test verifies that the HP 89440A meets its RF source specification for average noise level. In this test, the RF spectrum analyzer measures the noise of the RF source using the marker noise function.

1 Option AY8 only

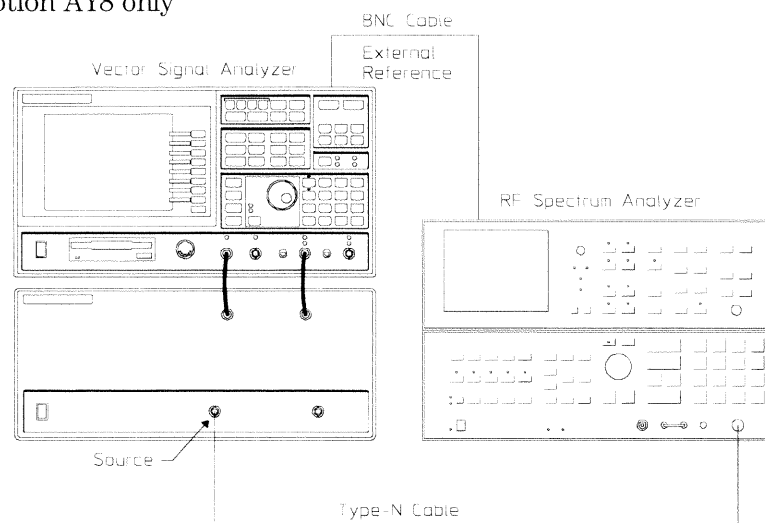

ITM_89440A Main Menu Descriptions

If you do not have a keyboard connected to the analyzer, use the numeric key pad and the alpha keys to enter names or numbers. See the analyzer's help text for a description of the alpha keys.

Load and run the ITM_89440A program to display the following softkeys:

[START TESTING]

Displays a menu that allows you to start testing with any test or to select just one test in the list. Before pressing this softkey, use [TEST CONFIG] and [EQUIP CONFIG]. See "Start Testing Menu Descriptions" for additional information.

[TEST CONFIG]

Displays the test configuration and a menu that allows you to enter the procedure, stop conditions, beeper prompt, and HP-IB address for the analyzer and printer. See "Test Configuration Menu Descriptions" for additional information.

[EQUIP CONFIG]

Displays the test equipment configuration and a menu that allows you to enter the model number, calibration due date, serial number, and HP-IB address for each test instrument. See "Equipment Configuration Menu Descriptions" for additional information.

[TITLE PAGE]

Displays the test record title page information and a menu that allows you to enter information for the analyzer. See "Title Page Menu Descriptions" for additional information.

[STOP ITM]

Stops the ITM_89440A program.

Start Testing Menu Descriptions

Press [START TESTING] to display the following softkeys:

[START BEGINNING]

Prints the test record title page information and starts the selected test procedure at the beginning. The measurement results are written to a file on the disk and printed only after all tests are done.

[START MIDDLE]

Displays a list of all the tests in the selected procedure. Testing starts with the test you select and continues through the remainder of the tests in the list. The measurement results are printed immediately after each measurement.

[ONE TEST]

Displays all the tests in the selected procedure. The test you select is the only test performed. The measurement results are printed immediately after each measurement.

[RETURN]

Returns to the ITM_89440A main menu.

Start a test to display the following softkeys:

[STOP TESTING]

Stops the test and returns to the ITM_89440A main menu.

[RESTART TEST]

Starts the current test over. Any connection prompts are repeated.

[RESTART MEAS]

Starts the current measurement over.

The following softkeys also appear when the program is waiting for you to press [CONTINUE]:

[STOP BEEPING]

Turns off the beeper prompt for the remainder of this measurement.

[CONTINUE]

Continues the test. Press this key after following the directions on the display.

Test Configuration Menu Descriptions

Press [TEST CONFIG] to display the test configuration and the following softkeys:

[HP 89440A ADDRESS]

Prompts you to enter the HP-IB address for the HP 89440A DC-1800 MHz Vector Signal Analyzer.

The HP-IB address equals $100 \times$ (interface select code) + (primary address). The interface select code for the printer and test equipment is 7 (for example, if the primary address is 8, the HP-IB address is 708).

[PRINTER ADDRESS]

Prompts you to enter the HP-IB address for the printer. To disable the printer, set the printer address to 0.

[PROCEDURE]

Prompts you to select the operation verification procedure (OP_VERIFY) or the performance test procedure (PERFORMAN).

[STOP AFTER]

Prompts you to select stop after limit failure, stop after each measurement, or do not stop after a limit failure or measurement. If [Limit Failure] is selected, the program stops after the failing measurement is displayed but before it is printed. At this point you can continue on and print the failing measurement or restart the measurement.

[BEEPER]

Toggles the beeper on and off. When the beeper is on, the program beeps approximately every 2 minutes while waiting for you to follow the directions on the display and press [CONTINUE].

[RETURN]

Returns to the ITM_89440A main menu.

Equipment Configuration Menu Descriptions

Press [EQUIP CONFIG] to display the test equipment configuration and the following softkeys:

[SYNTHESIZER]

Prompts you to enter the model, serial number, HP-IB address, and calibration due date for the frequency synthesizer.

If you select [OTHER] for model, the program prompts you to type in a model, serial number, and calibration due date but not an HP-IB address.

When entering the calibration due date, only four characters are displayed on the screen. However, you can enter up to nine characters and they will be printed.

[SYNTH/LVL GEN]

Prompts you to enter the model, serial number, HP-IB address, and calibration due date for the synthesizer/level generator.

[BASEBAND ANALYZER]

Prompts you to enter the model, serial number, HP-IB address, and calibration due date for the baseband spectrum analyzer.

[MULTIMETER]

Prompts you to enter the model, serial number, HP-IB address, and calibration due date for the digital multimeter.

[STEP_ATT 1DB]

Prompts you to enter the model, serial number, and calibration due date and data for the 1 dB step attenuator.

[STEP_ATT 10DB]

Prompts you to enter the model, serial number, and calibration due date and data for the 10 dB step attenuator.

[SIGNAL GENERATOR]

Prompts you to enter the model, serial number, HP-IB address, and calibration due date for the signal generator.

[POWER METER]

Prompts you to enter the model, serial number, HP-IB address, and calibration due date for the power meter.

[POWER SENSOR]

Prompts you to enter the model, serial number, and calibration due date and data for the power sensor.

[mW-POWER METER]

Prompts you to enter the model, serial number, and calibration due date for the milliwatt power meter.

[RF ANALYZER]

Prompts you to enter the model, serial number, HP-IB address, and calibration due date for the RF spectrum analyzer.

[SAVE SETUP]

Saves the current equipment configuration to a file for future recall.

[RECALL SETUP]

Recalls an equipment configuration that was previously saved using [SAVE SETUP].

Title Page Menu Descriptions

Press [TITLE PAGE] to display the title page information and the following softkeys:

[TEST FACILITY]

Prompts you to enter the name or number of the testing entity.

[FACILITY ADDRESS]

Prompts you to enter the address of the testing entity.

[TESTED BY]

Prompts you to enter the name or number of the person performing the test.

[REPORT NUMBER]

Prompts you to enter the analyzer's report number.

[CUSTOMER]

Prompts you to enter the name or number of the person requesting the test.

[SERIAL NUMBER]

Prompts you to enter the analyzer's serial number.

[MORE]

Displays the next page.

[RETURN]

Prompts you to return to the ITM_89440A main menu.

[OPTIONS]

Prompts you to enter the analyzer's options.

[DATE]

Prompts you to enter the test date.

[TEMP]

Prompts you to enter the temperature of the environment during the test.

[HUMIDITY]

Prompts you to enter the humidity of the environment during the test.

[LINE FREQUENCY]

Prompts you to enter the power line frequency.

[MORE]

Displays the first page.

[RETURN]

Returns to the ITM_89440A main menu.

The title page information is printed at the beginning of the test procedure.

Measurement Uncertainty

The following table lists the measurement uncertainty and ratio for each performance test using the recommended test equipment. Except for the Intermodulation Distortion performance test, the ratios listed for the recommended test equipment meet or exceed the measurement uncertainty ratio required by U.S. MIL-STD-45662A.

- If you are using equipment other than the recommended test equipment, you may calculate and record the measurement uncertainty and ratio for each performance test.

The table may be reproduced without written permission of Hewlett-Packard.

Performance Test	Using Recommended Test Equipment		Using Other Test Equipment	
	Measurement Uncertainty	Ratio	Measurement Uncertainty	Ratio
Self Test	NA	NA		
Amplitude Accuracy				
–30 dBm	±0.056 dB	> 10:1		
–18 dBm	±0.053 dB	> 10:1		
–6 dBm	±0.047 dB	> 10:1		
6 dBm	±0.053 dB	> 10:1		
18 dBm	±0.047 dB	> 10:1		
Amplitude Linearity				
–10 dB	±0.006 dB	> 10:1		
–20 dB	±0.006 dB	> 10:1		
–30 dB	±0.006 dB	> 10:1		
–40 dB	±0.006 dB	> 10:1		
–50 dB	±0.015 dB	10:1		
–60 dB	±0.015 dB	> 10:1		
–70 dB	±0.015 dB	> 10:1		
Amp Phase Match				
magnitude	0.046 dB	5.4:1		
phase	0.0052 degree	> 10:1		
Intermodulation Distortion	±3.3 dB	3.1:1 †		
Input Coupling	NA	NA		
Input Trigger	NA	NA		
External Trigger	NA	NA		
External Arm	NA	NA		

NA (not applicable) internal test

† If measured value is within ±2 dB of specification, verify distortion products of the test signal.

Performance Test	Using Recommended Test Equipment		Using Other Test Equipment	
	Measurement Uncertainty	Ratio	Measurement Uncertainty	Ratio
Harmonic Distortion	± 0.9 dB	> 10:1		
Input Capacitance	± 2.5 pF	> 10:1		
Input Resistance	510 Ω	> 10:1		
DC Offset	NA	NA		
Spurious Signals	NA	NA		
Noise	NA	NA		
Cross Talk				
Source-to-input	NA	NA		
Channel-to-channel	± 0.6 dB	> 10:1		
Anti-Alias Filter				
< 25 MHz	± 0.145 dB	> 10:1		
> 25 MHz	± 0.225 dB	> 10:1		
Source Amplitude Accuracy				
> -26.98 dBm	± 0.145 dB	> 10:1		
< -26.98 dBm and > -46.98 dBm	± 0.150 dB	> 10:1		
< -46.98 dBm	± 0.210 dB	> 10:1		
Input Rtn Loss	± 1.5 dB	6.3:1		
Source Rtn Loss	± 1.5 dB	6.3:1		
Source Distortion				
≤ 10 kHz	± 1.1 dB	8.4:1		
> 10 kHz	± 1.5 dB	6.3:1		
RF-Amplitude Accuracy	± 0.183 dB	5.5:1		
Phase Noise	± 1.5 dB	6.3:1		
LO Spurs	± 1.5 dB	6.3:1		
RF-Spurious Signals	± 1.5 dB	6.3:1		
RF-Harmonic Distortion	± 1.5 dB	6.3:1		
Frequency Accuracy	± 0.1295 Hz	> 10:1		
RF-Noise	NA	NA		
RF-Source Amplitude Accuracy				
absolute accuracy	± 0.113 dB	> 10:1		
flatness	± 0.113 dB	> 10:1		
RF-Source IF-Flatness	± 0.113 dB	> 10:1		
RF-Source Distortion	± 1.44 dB	6.5:1		
RF-Source Noise	± 1.82 dB	5.3:1		

NA (not applicable) internal test

Performance Test Record

Test Facility _____

Facility Address _____

Tested By _____

Report Number _____

Customer Name _____

HP 89410A Serial Number _____

HP 89430A Serial Number _____

Installed Options _____

Date _____

Temperature _____

Humidity _____

Power Line Frequency _____

Test Instruments Used

Instrument	Model	ID or Serial Number	Calibration Due
Synthesizer			
Synthesizer/Level Generator			
Baseband Analyzer			
Multimeter			
Step Attenuator, 1 dB			
Step Attenuator, 10 dB			
Signal Generator			
Power Meter			
Power Sensor			
Milliwatt Power Meter			
RF Analyzer			

Serial Number: _____ Report Number: _____
Test Date: ___/___/___

Self Test

Measurement	Lower Limit	Upper Limit	Measured Value	Pass/Fail
Long Confidence				

Amplitude Accuracy

Measurement	Lower Limit (dBm)	Upper Limit (dBm)	Measured Value (dBm)	Pass/Fail
9.876 MHz, -30 dBm, Ch 1, 50 ohm	-0.5	0.5		
9.876 MHz, -18 dBm, Ch 1, 50 ohm	-0.5	0.5		
9.876 MHz, -6 dBm, Ch 1, 50 ohm	-0.5	0.5		
9.876 MHz, 6 dBm, Ch 1, 50 ohm	-0.5	0.5		
9.876 MHz, 18 dBm, Ch 1, 50 ohm	-0.5	0.5		
9.876 MHz, -30 dBm, Ch 1, 1 Mohm	-0.5	0.5		
9.876 MHz, -18 dBm, Ch 1, 1 Mohm	-0.5	0.5		
9.876 MHz, -6 dBm, Ch 1, 1 Mohm	-0.5	0.5		
9.876 MHz, 6 dBm, Ch 1, 1 Mohm	-0.5	0.5		
9.876 MHz, 18 dBm, Ch 1, 1 Mohm	-0.5	0.5		
9.876 MHz, -30 dBm, Ch 2, 50 ohm †	-0.5	0.5		
9.876 MHz, -18 dBm, Ch 2, 50 ohm †	-0.5	0.5		
9.876 MHz, -6 dBm, Ch 2, 50 ohm †	-0.5	0.5		
9.876 MHz, 6 dBm, Ch 2, 50 ohm †	-0.5	0.5		
9.876 MHz, 18 dBm, Ch 2, 50 ohm †	-0.5	0.5		
9.876 MHz, -30 dBm, Ch 2, 1 Mohm †	-0.5	0.5		
9.876 MHz, -18 dBm, Ch 2, 1 Mohm †	-0.5	0.5		
9.876 MHz, -6 dBm, Ch 2, 1 Mohm †	-0.5	0.5		
9.876 MHz, 6 dBm, Ch 2, 1 Mohm †	-0.5	0.5		
9.876 MHz, 18 dBm, Ch 2, 1 Mohm †	-0.5	0.5		

† Option AY7 only

Serial Number: _____ Report Number: _____
 Test Date: __/__/__

Amplitude Accuracy (continued)

Measurement	Lower Limit (dBm)	Upper Limit (dBm)	Measured Value (dBm)	Pass/Fail
49.234 kHz, -30 dBm, Ch 1, 50 ohm	-0.5	0.5		
49.234 kHz, -18 dBm, Ch 1, 50 ohm	-0.5	0.5		
49.234 kHz, -6 dBm, Ch 1, 50 ohm	-0.5	0.5		
49.234 kHz, 6 dBm, Ch 1, 50 ohm	-0.5	0.5		
49.234 kHz, 18 dBm, Ch 1, 50 ohm	-0.5	0.5		
49.234 kHz, -30 dBm, Ch 1, 1 Mohm	-0.5	0.5		
49.234 kHz, -18 dBm, Ch 1, 1 Mohm	-0.5	0.5		
49.234 kHz, -6 dBm, Ch 1, 1 Mohm	-0.5	0.5		
49.234 kHz, 6 dBm, Ch 1, 1 Mohm	-0.5	0.5		
49.234 kHz, 18 dBm, Ch 1, 1 Mohm	-0.5	0.5		
49.234 kHz, -30 dBm, Ch 2, 50 ohm †	-0.5	0.5		
49.234 kHz, -18 dBm, Ch 2, 50 ohm †	-0.5	0.5		
49.234 kHz, -6 dBm, Ch 2, 50 ohm †	-0.5	0.5		
49.234 kHz, 6 dBm, Ch 2, 50 ohm †	-0.5	0.5		
49.234 kHz, 18 dBm, Ch 2, 50 ohm †	-0.5	0.5		
49.234 kHz, -30 dBm, Ch 2, 1 Mohm †	-0.5	0.5		
49.234 kHz, -18 dBm, Ch 2, 1 Mohm †	-0.5	0.5		
49.234 kHz, -6 dBm, Ch 2, 1 Mohm †	-0.5	0.5		
49.234 kHz, 6 dBm, Ch 2, 1 Mohm †	-0.5	0.5		
49.234 kHz, 18 dBm, Ch 2, 1 Mohm †	-0.5	0.5		

† Option AY7 only

Serial Number: _____ Report Number: _____
Test Date: ___/___/___

Amplitude Linearity

Measurement	Lower Limit (dB)	Upper Limit (dB)	Measured Value (dB)	Pass/Fail
-10 dB, Ch 1	-0.1	0.1		
-20 dB, Ch 1	-0.1	0.1		
-30 dB, Ch 1	-0.1	0.1		
-40 dB, Ch 1	-0.15	0.15		
-50 dB, Ch 1	-0.15	0.15		
-60 dB, Ch 1	-0.2	0.2		
-70 dB, Ch 1	-0.2	0.2		
-10 dB, Ch 2 †	-0.1	0.1		
-20 dB, Ch 2 †	-0.1	0.1		
-30 dB, Ch 2 †	-0.1	0.1		
-40 dB, Ch 2 †	-0.15	0.15		
-50 dB, Ch 2 †	-0.15	0.15		
-60 dB, Ch 2 †	-0.2	0.2		
-70 dB, Ch 2 †	-0.2	0.2		

† Option AY7 only

Serial Number: _____ Report Number: _____
 Test Date: __/__/__

Amp_Phase Match (Option AY7 only)

Measurement	Lower Limit	Upper Limit	Measured Value	Pass/Fail
-30 dBm Magnitude	-0.25 dB	0.25 dB		
-30 dBm Phase	-2 deg	2 deg		
-22 dBm Magnitude	-0.25 dB	0.25 dB		
-22 dBm Phase	-2 deg	2 deg		
-14 dBm Magnitude	-0.25 dB	0.25 dB		
-14 dBm Phase	-2 deg	2 deg		
-6 dBm Magnitude	-0.25 dB	0.25 dB		
-6 dBm Phase	-2 deg	2 deg		
2 dBm Magnitude	-0.25 dB	0.25 dB		
2 dBm Phase	-2 deg	2 deg		
10 dBm Magnitude	-0.25 dB	0.25 dB		
10 dBm Phase	-2 deg	2 deg		

Intermodulation Distortion

Measurement	Lower Limit	Upper Limit (dBm)	Measured Value (dBm)	Pass/Fail
A + B, Ch 1		-111		
B-A, Ch 1		-111		
2A-B, Ch 1		-111		
2B-A, Ch 1		-111		
A + B, Ch 2 †		-111		
B-A, Ch 2 †		-111		
2A-B, Ch 2 †		-111		
2B-A, Ch 2 †		-111		

† Option AY7 only

Serial Number: _____ Report Number: _____
Test Date: ___/___/___

Input Coupling

Measurement	Lower Limit	Upper Limit (dB)	Measured Value (dB)	Pass/Fail
dc – ac, Ch 1		3		
dc – ac, Ch 2 †		3		

† Option AY7 only

Input Trigger

Measurement	Lower Limit (V)	Upper Limit (V)	Measured Value (V)	Pass/Fail
Channel 1, +2 Volt, Slope Positive	1.368	2.632		
Channel 1, +2 Volt, Slope Negative	1.368	2.632		
Channel 1, –2 Volt, Slope Positive	–2.632	–1.368		
Channel 1, –2 Volt, Slope Negative	–2.632	–1.368		
Channel 2, +2 Volt, Slope Positive †	1.368	2.632		
Channel 2, +2 Volt, Slope Negative †	1.368	2.632		
Channel 2, –2 Volt, Slope Positive †	–2.632	–1.368		
Channel 2, –2 Volt, Slope Negative †	–2.632	–1.368		

† Option AY7 only

External Trigger

Measurement	Lower Limit (V)	Upper Limit (V)	Measured Value (V)	Pass/Fail
+5 Volt, Slope Positive	4.5	5.5		
+5 Volt, Slope Negative	4.5	5.5		
–5 Volt, Slope Positive	–5.5	–4.5		
–5 Volt, Slope Negative	–5.5	–4.5		

Serial Number: _____ Report Number: _____
 Test Date: ___/___/___

External Arm

Measurement	Lower Limit (V)	Upper Limit (V)	Measured Value (V)	Pass/Fail
+2 Volt, Region Above	1.5	2.5		
-2 Volt, Region Below	-2.5	-1.5		

Harmonic Distortion

Measurement	Lower Limit	Upper Limit (dBc)	Measured Value (dBc)	Pass/Fail
9.75 MHz 2nd, Ch 1		-75		
9.75 MHz 3rd, Ch 1		-75		
9.75 MHz 2nd, Ch 2 †		-75		
9.75 MHz 3rd, Ch 2 †		-75		
3.33 MHz 2nd, Ch 1		-75		
3.33 MHz 3rd, Ch 1		-75		
3.33 MHz 2nd, Ch 2 †		-75		
3.33 MHz 3rd, Ch 2 †		-75		

† Option AY7 only

Input Capacitance

Measurement	Lower Limit	Upper Limit (pF)	Measured Value (pF)	Pass/Fail
Channel 1		80		
Channel 2 †		80		

† Option AY7 only

Serial Number: _____ Report Number: _____
Test Date: ___/___/___

Input Resistance

Measurement	Lower Limit (M Ω)	Upper Limit (M Ω)	Measured Value (M Ω)	Pass/Fail
20 dBm, Ch 1	0.98	1.02		
-10 dBm, Ch 1	0.98	1.02		
-30 dBm, Ch 1	0.98	1.02		
20 dBm, Ch 2 †	0.98	1.02		
-10 dBm, Ch 2 †	0.98	1.02		
-30 dBm, Ch 2 †	0.98	1.02		

† Option AY7 only

Serial Number: _____ Report Number: _____
 Test Date: ___/___/___

DC Offset

Measurement	Lower Limit	Upper Limit (dBfs)	Measured Value (dBfs)	Pass/Fail
-30 dBm, Ch 1, Filter In		-25		
-20 dBm, Ch 1, Filter In		-25		
-10 dBm, Ch 1, Filter In		-25		
0 dBm, Ch 1, Filter In		-25		
+ 10 dBm, Ch 1, Filter In		-25		
+ 20 dBm, Ch 1, Filter In		-25		
-30 dBm, Ch 1, Filter Out		-25		
-20 dBm, Ch 1, Filter Out		-25		
-10 dBm, Ch 1, Filter Out		-25		
0 dBm, Ch 1, Filter Out		-25		
+ 10 dBm, Ch 1, Filter Out		-25		
+ 20 dBm, Ch 1, Filter Out		-25		
-30 dBm, Ch 2, Filter In †		-25		
-20 dBm, Ch 2, Filter In †		-25		
-10 dBm, Ch 2, Filter In †		-25		
0 dBm, Ch 2, Filter In †		-25		
+ 10 dBm, Ch 2, Filter In †		-25		
+ 20 dBm, Ch 2, Filter In †		-25		
-30 dBm, Ch 2, Filter Out †		-25		
-20 dBm, Ch 2, Filter Out †		-25		
-10 dBm, Ch 2, Filter Out †		-25		
0 dBm, Ch 2, Filter Out †		-25		
+ 10 dBm, Ch 2, Filter Out †		-25		
+ 20 dBm, Ch 2, Filter Out †		-25		

† Option AY7 only

Serial Number: _____ Report Number: _____
Test Date: ___/___/___

Spurious Signals

Measurement	Lower Limit	Upper Limit (dBm)	Measured Value (dBm)	Pass/Fail
275 Hz Center, 450 Hz Span, Ch 1		-99		
275 Hz Center, 450 Hz Span, Ch 2 †		-99		
25 kHz Center, 10 kHz Span, Ch 1		-99		
25 kHz Center, 10 kHz Span, Ch 2 †		-99		
100 kHz Center, 50 kHz Span, Ch 1		-99		
100 kHz Center, 50 kHz Span, Ch 2 †		-99		
200 kHz Center, 50 kHz Span, Ch 1		-99		
200 kHz Center, 50 kHz Span, Ch 2 †		-99		
300 kHz Center, 50 kHz Span, Ch 1		-99		
300 kHz Center, 50 kHz Span, Ch 2 †		-99		
400 kHz Center, 50 kHz Span, Ch 1		-99		
400 kHz Center, 50 kHz Span, Ch 2 †		-99		

† Option AY7 only

Noise

Measurement	Lower Limit	Upper Limit (dBm/Hz)	Measured Value (dBm/Hz)	Pass/Fail
1 kHz to 40 kHz, Ch 1		-131		
1 kHz to 40 kHz, Ch 2 †		-131		
40 kHz to 10 MHz, Ch 1		-144		
40 kHz to 10 MHz, Ch 2 †		-144		

† Option AY7 only

Serial Number: _____ Report Number: _____
 Test Date: ___/___/___

Cross Talk

Measurement	Lower Limit	Upper Limit (dBm)	Measured Value (dBm)	Pass/Fail
Source-to-Ch 1		-115		
Source-to-Ch 2 †		-115		
Ch 2-to-Ch 1 †		-115		
Ch 1-to-Ch 2 †		-115		

† Option AY7 only

Anti-Alias Filter

Measurement	Lower Limit	Upper Limit (dB)	Measured Value (dB)	Pass/Fail
15.654 MHz, Ch 1		-80		
22.454 MHz, Ch 1		-80		
29.254 MHz, Ch 1		-80		
41.254 MHz, Ch 1		-80		
48.054 MHz, Ch 1		-80		
54.854 MHz, Ch 1		-80		
66.854 MHz, Ch 1		-80		
73.654 MHz, Ch 1		-80		
15.654 MHz, Ch 2 †		-80		
22.454 MHz, Ch 2 †		-80		
29.254 MHz, Ch 2 †		-80		
41.254 MHz, Ch 2 †		-80		
48.054 MHz, Ch 2 †		-80		
54.854 MHz, Ch 2 †		-80		
66.854 MHz, Ch 2 †		-80		
73.654 MHz, Ch 2 †		-80		

† Option AY7 only

Serial Number: _____ Report Number: _____
Test Date: ___/___/___

Source Amplitude Accuracy

Measurement	Lower Limit (dB)	Upper Limit (dB)	Measured Value (dB)	Pass/Fail
9.5 MHz, -56 dBm	-2	2		
9.5 MHz, -50 dBm	-2	2		
9.5 MHz, -41 dBm	-1	1		
9.5 MHz, -35 dBm	-1	1		
9.5 MHz, -32 dBm	-1	1		
9.5 MHz, -23 dBm	-1	1		
9.5 MHz, -14 dBm	-1	1		
9.5 MHz, -8 dBm	-1	1		
9.5 MHz, 1 dBm	-1	1		
9.5 MHz, 4 dBm	-1	1		
9.5 MHz, 13 dBm	-1	1		
30 kHz, 13 dBm	-1	1		
1.8 MHz, 13 dBm	-1	1		
3.3 MHz, 13 dBm	-1	1		
4.8 MHz, 13 dBm	-1	1		
6.3 MHz, 13 dBm	-1	1		
7.8 MHz, 13 dBm	-1	1		
9.95 MHz, 13 dBm	-1	1		

Serial Number: _____ Report Number: _____
 Test Date: ___/___/___

Input Rtn Loss

Measurement	Lower Limit	Upper Limit (dB)	Measured Value (dB)	Pass/Fail
Channel 1, 50 ohm, -20 dBm		-25		
Channel 1, 50 ohm, -22 dBm		-25		
Channel 2, 50 ohm, -20 dBm †		-25		
Channel 2, 50 ohm, -22 dBm †		-25		
Channel 1, 75 ohm, -20 dBm		-20		
Channel 1, 75 ohm, -22 dBm		-20		
Channel 2, 75 ohm, -20 dBm †		-20		
Channel 2, 75 ohm, -22 dBm †		-20		

† Option AY7 only

Source Rtn Loss

Measurement	Lower Limit	Upper Limit (dB)	Measured Value (dB)	Pass/Fail
50 ohm, 0 dB Attenuator		-20		
50 ohm, 10 dB Attenuator		-20		
50 ohm, 20 dB Attenuator		-20		
50 ohm, 40 dB Attenuator		-20		
75 ohm, 0 dB Attenuator		-20		
75 ohm, 10 dB Attenuator		-20		
75 ohm, 20 dB Attenuator		-20		
75 ohm, 40 dB Attenuator		-20		

Serial Number: _____ Report Number: _____
Test Date: ___/___/___

Source Distortion

Measurement	Lower Limit	Upper Limit (dBc)	Measured Value (dBc)	Pass/Fail
2.395 kHz @ 6 dBm		-55		
7.84 kHz @ 6 dBm		-55		
65.8 kHz @ 6 dBm		-40		
3.925 MHz @ 6 dBm		-40		
9.64 MHz @ 6 dBm		-33		
2.395 kHz @ 13 dBm		-55		
7.84 kHz @ 13 dBm		-55		
65.8 kHz @ 13 dBm		-40		
3.925 MHz @ 13 dBm		-40		
9.64 MHz @ 13 dBm		-33		

RF-Amplitude Accuracy

Measurement	Lower Limit (dB)	Upper Limit (dB)	Measured Value (dB)	Pass/Fail
-20 dBm Range	-1	1		
-15 dBm Range	-1	1		
-10 dBm Range	-1	1		
-5 dBm Range	-1	1		
0 dBm Range	-1	1		
5 dBm Range	-1	1		
10 dBm Range	-1	1		
15 dBm Range	-1.1	1.1		
20 dBm Range	-1.1	1.1		
25 dBm Range	-1.1	1.1		

Serial Number: _____ Report Number: _____
 Test Date: __/__/__

Phase Noise

Measurement	Lower Limit	Upper Limit (dBc/Hz)	Measured Value (dBc/Hz)	Pass/Fail
100 Hz Offset			-89	
1 kHz Offset			-92	
10 kHz Offset			-93	
100 kHz Offset			-105	

LO Spurs

Measurement	Lower Limit	Upper Limit (dBc)	Measured Value (dBc)	Pass/Fail
25.51 kHz Offset			-70	
51.02 kHz Offset			-70	
76.53 kHz Offset			-70	
100 kHz Offset			-70	
200 kHz Offset			-70	
300 kHz Offset			-70	

Serial Number: _____ Report Number: _____
Test Date: ___/___/___

RF-Spurious Signals

Measurement	Lower Limit	Upper Limit (dBc)	Measured Value (dBc)	Pass/Fail
2 MHz Tuned, 7 MHz Input		-70		
4 MHz Tuned, 10 MHz Input		-70		
6 MHz Tuned, 10 MHz Input		-70		
8 MHz Tuned, 10 MHz Input		-70		
11 MHz Tuned, 822.6666666 MHz Input		-70		
11 MHz Tuned, 1641.6666666 MHz Input		-70		
11 MHz Tuned, 1234 MHz Input		-70		
199 MHz Tuned, 948 MHz Input		-70		
199 MHz Tuned, 1422 MHz Input		-70		
399 MHz Tuned, 1081.3333333 MHz Input		-70		
399 MHz Tuned, 1622 MHz Input		-70		

RF-Harmonic Distortion

Measurement	Lower Limit	Upper Limit (dBc)	Measured Value (dBc)	Pass/Fail
159.001 MHz, 2nd		-70		
159.001 MHz, 3rd		-70		
159.001 MHz, 4th		-70		
159.001 MHz, 5th		-70		
679.001 MHz, 2nd		-70		

Serial Number: _____ Report Number: _____
 Test Date: ___/___/___

Frequency Accuracy

Measurement	Lower Limit (MHz)	Upper Limit (MHz)	Measured Value (MHz)	Pass/Fail
Accuracy at 1500 MHz				

RF-Noise

Measurement	Lower Limit	Upper Limit (dBm/Hz)	Measured Value (dBm/Hz)	Pass/Fail
2.345 MHz		-145		
23.456 MHz		-145		
123.456 MHz		-145		
523.456 MHz		-145		
923.456 MHz		-145		
1.323456 GHz		-145		
1.723456 GHz		-145		

RF-Source Amplitude Accuracy (Option AY8 only)

Measurement	Lower Limit	Upper Limit	Measured Value	Pass/Fail
Absolute accuracy, 6 MHz, 5 dBm	3 dBm	7 dBm	dBm	
13 dBm flatness	-2 dB	2 dB	dB	

RF-Source IF-Flatness (Option AY8 only)

Measurement	Lower Limit (dB)	Upper Limit (dB)	Measured Value (dB)	Pass/Fail
IF flatness	-2	2		

Serial Number: _____ Report Number: _____
Test Date: __/__/__

RF-Source Distortion (Option AY8 only)

Measurement	Lower Limit	Upper Limit (dBc)	Measured Value (dBc)	Pass/Fail
2.123 MHz, 2nd		-25		
2.123 MHz, 3rd		-25		
2.123 MHz, 4th		-25		
2.123 MHz, 5th		-25		
159.123 MHz, 2nd		-25		
159.123 MHz, 3rd		-25		
159.123 MHz, 4th		-25		
159.123 MHz, 5th		-25		
479.123 MHz, 2nd		-25		
479.123 MHz, 3rd		-25		
479.123 MHz, 4th		-25		
479.123 MHz, 5th		-25		
889.123 MHz, 2nd		-25		
889.123 MHz, 3rd		-25		
1399.123 MHz, 2nd		-25		
1399.123 MHz, 3rd		-25		

RF-Source Noise (Option AY8 only)

Measurement	Lower Limit	Upper Limit (dBc/Hz)	Measured Value (dBc/Hz)	Pass/Fail
6 MHz, 100 kHz Offset		-100		
6 MHz, 1 MHz Offset		-100		
6 MHz, 2 MHz Offset		-100		
6 MHz, 3 MHz Offset		-100		
6 MHz, 4 MHz Offset		-100		

Operation Verification Test Record

Test Facility _____

Facility Address _____

Tested By _____

Report Number _____

Customer Name _____

HP 89410A Serial Number _____

HP 89430A Serial Number _____

Installed Options _____

Date _____

Temperature _____

Humidity _____

Power Line Frequency _____

Test Instruments Used

Instrument	Model	ID or Serial Number	Calibration Due
Synthesizer			
Synthesizer/Level Generator			
Baseband Analyzer			
Multimeter			
Step Attenuator, 1 dB			
Step Attenuator, 10 dB			
Signal Generator			
Power Meter			
Power Sensor			
Milliwatt Power Meter			
RF Analyzer			

Serial Number: _____ Report Number: _____
 Test Date: ___/___/___

Self Test

Measurement	Lower Limit	Upper Limit	Measured Value	Pass/Fail
Long Confidence				

Amplitude Accuracy

Measurement	Lower Limit (dBm)	Upper Limit (dBm)	Measured Value (dBm)	Pass/Fail
9.876 MHz, -18 dBm, Ch 1, 50 ohm	-0.5	0.5		
9.876 MHz, 6 dBm, Ch 1, 50 ohm	-0.5	0.5		
9.876 MHz, -18 dBm, Ch 1, 1 Mohm	-0.5	0.5		
9.876 MHz, 6 dBm, Ch 1, 1 Mohm	-0.5	0.5		
9.876 MHz, -18 dBm, Ch 2, 50 ohm †	-0.5	0.5		
9.876 MHz, 6 dBm, Ch 2, 50 ohm †	-0.5	0.5		
9.876 MHz, -18 dBm, Ch 2, 1 Mohm †	-0.5	0.5		
9.876 MHz, 6 dBm, Ch 2, 1 Mohm †	-0.5	0.5		
49.234 kHz, -18 dBm, Ch 1, 50 ohm	-0.5	0.5		
49.234 kHz, 6 dBm, Ch 1, 50 ohm	-0.5	0.5		
49.234 kHz, -18 dBm, Ch 1, 1 Mohm	-0.5	0.5		
49.234 kHz, 6 dBm, Ch 1, 1 Mohm	-0.5	0.5		
49.234 kHz, -18 dBm, Ch 2, 50 ohm †	-0.5	0.5		
49.234 kHz, 6 dBm, Ch 2, 50 ohm †	-0.5	0.5		
49.234 kHz, -18 dBm, Ch 2, 1 Mohm †	-0.5	0.5		
49.234 kHz, 6 dBm, Ch 2, 1 Mohm †	-0.5	0.5		

† Option AY7 only

Serial Number: _____ Report Number: _____
 Test Date: __/__/__

Amp_Phase Match (Option AY7 only)

Measurement	Lower Limit	Upper Limit	Measured Value	Pass/Fail
-30 dBm Magnitude	-0.25 dB	0.25 dB		
-30 dBm Phase	-2 deg	2 deg		
-22 dBm Magnitude	-0.25 dB	0.25 dB		
-22 dBm Phase	-2 deg	2 deg		
-14 dBm Magnitude	-0.25 dB	0.25 dB		
-14 dBm Phase	-2 deg	2 deg		
-6 dBm Magnitude	-0.25 dB	0.25 dB		
-6 dBm Phase	-2 deg	2 deg		
2 dBm Magnitude	-0.25 dB	0.25 dB		
2 dBm Phase	-2 deg	2 deg		
10 dBm Magnitude	-0.25 dB	0.25 dB		
10 dBm Phase	-2 deg	2 deg		

Input Coupling

Measurement	Lower Limit	Upper Limit (dB)	Measured Value (dB)	Pass/Fail
dc – ac, Ch 1		3		
dc – ac, Ch 2 †		3		

† Option AY7 only

Serial Number: _____ Report Number: _____
 Test Date: ___/___/___

Input Trigger

Measurement	Lower Limit (V)	Upper Limit (V)	Measured Value (V)	Pass/Fail
Channel 1, +2 Volt, Slope Negative	1.368	2.632		
Channel 1, -2 Volt, Slope Positive	-2.632	-1.368		
Channel 2, +2 Volt, Slope Negative †	1.368	2.632		
Channel 2, -2 Volt, Slope Positive †	-2.632	-1.368		

† Option AY7 only

External Trigger

Measurement	Lower Limit (V)	Upper Limit (V)	Measured Value (V)	Pass/Fail
+5 Volt, Slope Negative	4.5	5.5		
-5 Volt, Slope Positive	-5.5	-4.5		

External Arm

Measurement	Lower Limit (V)	Upper Limit (V)	Measured Value (V)	Pass/Fail
+2 Volt, Region Above	1.5	2.5		
-2 Volt, Region Below	-2.5	-1.5		

Harmonic Distortion

Measurement	Lower Limit	Upper Limit (dBc)	Measured Value (dBc)	Pass/Fail
9.75 MHz 2nd, Ch 1		-75		
9.75 MHz 3rd, Ch 1		-75		
9.75 MHz 2nd, Ch 2 †		-75		
9.75 MHz 3rd, Ch 2 †		-75		

† Option AY7 only

Serial Number: _____ Report Number: _____
 Test Date: ___/___/___

DC Offset

Measurement	Lower Limit	Upper Limit (dBfs)	Measured Value (dBfs)	Pass/Fail
-30 dBm, Ch 1, Filter In		-25		
-20 dBm, Ch 1, Filter In		-25		
-10 dBm, Ch 1, Filter In		-25		
0 dBm, Ch 1, Filter In		-25		
+ 10 dBm, Ch 1, Filter In		-25		
+ 20 dBm, Ch 1, Filter In		-25		
-30 dBm, Ch 2, Filter In †		-25		
-20 dBm, Ch 2, Filter In †		-25		
-10 dBm, Ch 2, Filter In †		-25		
0 dBm, Ch 2, Filter In †		-25		
+ 10 dBm, Ch 2, Filter In †		-25		
+ 20 dBm, Ch 2, Filter In †		-25		

† Option AY7 only

Serial Number: _____ Report Number: _____
 Test Date: ___/___/___

Spurious Signals

Measurement	Lower Limit	Upper Limit (dBm)	Measured Value (dBm)	Pass/Fail
275 Hz Center, 450 Hz Span, Ch 1			-99	
275 Hz Center, 450 Hz Span, Ch 2 †			-99	
25 kHz Center, 10 kHz Span, Ch 1			-99	
25 kHz Center, 10 kHz Span, Ch 2 †			-99	
100 kHz Center, 50 kHz Span, Ch 1			-99	
100 kHz Center, 50 kHz Span, Ch 2 †			-99	
200 kHz Center, 50 kHz Span, Ch 1			-99	
200 kHz Center, 50 kHz Span, Ch 2 †			-99	
300 kHz Center, 50 kHz Span, Ch 1			-99	
300 kHz Center, 50 kHz Span, Ch 2 †			-99	
400 kHz Center, 50 kHz Span, Ch 1			-99	
400 kHz Center, 50 kHz Span, Ch 2 †			-99	

† Option AY7 only

Noise

Measurement	Lower Limit	Upper Limit (dBm/Hz)	Measured Value (dBm/Hz)	Pass/Fail
1 kHz to 40 kHz, Ch 1			-131	
1 kHz to 40 kHz, Ch 2 †			-131	
40 kHz to 10 MHz, Ch 1			-144	
40 kHz to 10 MHz, Ch 2 †			-144	

† Option AY7 only

Serial Number: _____ Report Number: _____
 Test Date: __/__/__

Source Amplitude Accuracy

Measurement	Lower Limit (dB)	Upper Limit (dB)	Measured Value (dB)	Pass/Fail
9.5 MHz, -56 dBm	-2	2		
9.5 MHz, -50 dBm	-2	2		
9.5 MHz, -41 dBm	-1	1		
9.5 MHz, -35 dBm	-1	1		
9.5 MHz, -32 dBm	-1	1		
9.5 MHz, -23 dBm	-1	1		
9.5 MHz, -14 dBm	-1	1		
9.5 MHz, -8 dBm	-1	1		
9.5 MHz, 1 dBm	-1	1		
9.5 MHz, 4 dBm	-1	1		
9.5 MHz, 13 dBm	-1	1		
30 kHz, 13 dBm	-1	1		
1.8 MHz, 13 dBm	-1	1		
3.3 MHz, 13 dBm	-1	1		
4.8 MHz, 13 dBm	-1	1		
6.3 MHz, 13 dBm	-1	1		
7.8 MHz, 13 dBm	-1	1		
9.95 MHz, 13 dBm	-1	1		

Serial Number: _____ Report Number: _____
Test Date: ___/___/___

Source Distortion

Measurement	Lower Limit	Upper Limit (dBc)	Measured Value (dBc)	Pass/Fail
2.395 kHz @ 6 dBm		-55		
7.84 kHz @ 6 dBm		-55		
65.8 kHz @ 6 dBm		-40		
3.925 MHz @ 6 dBm		-40		
9.64 MHz @ 6 dBm		-33		

RF-Amplitude Accuracy

Measurement	Lower Limit (dB)	Upper Limit (dB)	Measured Value (dB)	Pass/Fail
-15 dBm Range	-1	1		
-10 dBm Range	-1	1		
-5 dBm Range	-1	1		
0 dBm Range	-1	1		
5 dBm Range	-1	1		
10 dBm Range	-1	1		

Phase Noise

Measurement	Lower Limit	Upper Limit (dBc/Hz)	Measured Value (dBc/Hz)	Pass/Fail
100 Hz Offset		-89		
1 kHz Offset		-92		
10 kHz Offset		-93		
100 kHz Offset		-105		

Serial Number: _____ Report Number: _____
 Test Date: __/__/__

RF-Spurious Signals

Measurement	Lower Limit	Upper Limit (dBc)	Measured Value (dBc)	Pass/Fail
2 MHz Tuned, 7 MHz Input		-70		
4 MHz Tuned, 10 MHz Input		-70		
6 MHz Tuned, 10 MHz Input		-70		
8 MHz Tuned, 10 MHz Input		-70		
11 MHz Tuned, 822.666666 MHz Input		-70		
11 MHz Tuned, 1641.666666 MHz Input		-70		
11 MHz Tuned, 1234 MHz Input		-70		
199 MHz Tuned, 948 MHz Input		-70		
199 MHz Tuned, 1422 MHz Input		-70		
399 MHz Tuned, 1081.333333 MHz Input		-70		
399 MHz Tuned, 1622 MHz Input		-70		

RF-Harmonic Distortion

Measurement	Lower Limit	Upper Limit (dBc)	Measured Value (dBc)	Pass/Fail
159.001 MHz, 2nd		-70		
159.001 MHz, 3rd		-70		
159.001 MHz, 4th		-70		
159.001 MHz, 5th		-70		

Frequency Accuracy

Measurement	Lower Limit (MHz)	Upper Limit (MHz)	Measured Value (MHz)	Pass/Fail
Accuracy at 1500 MHz				

Serial Number: _____ Report Number: _____
 Test Date: ___/___/___

RF-Noise

Measurement	Lower Limit	Upper Limit (dBm/Hz)	Measured Value (dBm/Hz)	Pass/Fail
2.345 MHz		-145		
123.456 MHz		-145		
923.456 MHz		-145		
1.723456 GHz		-145		

RF-Source Amplitude Accuracy (Option AY8 only)

Measurement	Lower Limit	Upper Limit	Measured Value	Pass/Fail
Absolute accuracy, 6 MHz, 5 dBm	3 dBm	7 dBm	dBm	
13 dBm flatness	-2 dB	2 dB	dB	

RF-Source IF-Flatness (Option AY8 only)

Measurement	Lower Limit (dB)	Upper Limit (dB)	Measured Value (dB)	Pass/Fail
IF flatness	-2	2		

RF-Source Distortion (Option AY8 only)

Measurement	Lower Limit	Upper Limit (dBc)	Measured Value (dBc)	Pass/Fail
2.123 MHz, 2nd		-25		
2.123 MHz, 3rd		-25		
2.123 MHz, 4th		-25		
2.123 MHz, 5th		-25		
479.123 MHz, 2nd		-25		
479.123 MHz, 3rd		-25		
479.123 MHz, 4th		-25		
479.123 MHz, 5th		-25		
1399.123 MHz, 2nd		-25		
1399.123 MHz, 3rd		-25		

Serial Number: _____ Report Number: _____
Test Date: __/__/__

RF-Source Noise (Option AY8 only)

Measurement	Lower Limit	Upper Limit (dBc/Hz)	Measured Value (dBc/Hz)	Pass/Fail
6 MHz, 100 kHz Offset		-100		
6 MHz, 1 MHz Offset		-100		
6 MHz, 2 MHz Offset		-100		
6 MHz, 3 MHz Offset		-100		
6 MHz, 4 MHz Offset		-100		

Index

A

- ac line voltage 1-2
- accessories v
- air circulation 1-9
- amplitude performance test
 - accuracy 2-19
 - accuracy, RF 2-63
 - linearity 2-25
 - phase match 2-27
 - source accuracy 2-53
 - source accuracy, RF 2-71
- anti-alias filter performance test 2-51
- assistance (*rear of manual*)
- AUI (attachment unit interface) port 1-14

C

- calibration
 - See* performance test
- capacitance performance test 2-41
- centronics port 1-15
- channel
 - input connectors iii
 - match performance test 2-27
 - optional IF input iv
- circulation, air 1-9
- cleaning the screen 1-20
- conformity, declaration of (*rear of manual*)
- connecting
 - frequency reference 1-7
 - IF section to RF section 1-7
 - minimum loss pad 1-19
- connector
 - AUI (attachment unit interface) 1-14
 - external monitor 1-17
 - external reference 1-7
 - front panel iii
 - grounding requirements 1-3
 - HP-IB 1-16
 - input 1-8

- connector (continued)
 - keyboard 1-18
 - oven reference 1-7
 - parallel 1-15
 - probe power iii
 - serial 1-15
 - source 1-8
 - system interconnect 1-16
 - ThinLAN 1-14
- cooling 1-9
- cords, power 1-3
- coupling performance test 2-32
- crosstalk performance test 2-49

D

- dc offset performance test 2-46
- declaration of conformity (*rear of manual*)
- disk drive iii
 - flexible disks for vi
 - loading performance test 2-12
- display
 - cleaning 1-20
 - connecting external 1-17
- distortion performance test
 - harmonic 2-38
 - harmonic, RF 2-67
 - intermodulation 2-29
 - source 2-62
 - source, RF 2-73

E

- environment, operating 1-9
- equipment required 2-3
- error message
 - insufficient memory 2-12
 - wrong disk 2-12
- external
 - arm performance test 2-37
 - frequency reference 1-7
 - keyboard 1-18

Index

external (continued)

- monitor 1-17
- trigger connector iii
- trigger performance test 2-36

F

failure

- power up 1-22
- stop frequency is 10 MHz 1-24
- firmware version (*rear of manual*)
- flatness test, RF source 2-72
- flexible disks vi
- frequency
 - accuracy performance test 2-69
 - reference 1-7
 - stop frequency is 10 MHz 1-24

front panel description iii

fuse 1-12

G

grounding requirements 1-3

H

harmonic distortion

- performance test 2-38
- performance test, RF 2-67

help (*rear of manual*)

HP-IB connector 1-16

I

IF section

- connecting to RF section 1-7
- fuse 1-12
- model number 1-10
- voltage selector switch 1-10

incoming inspection 1-5

input

- connector iii
- ordering optional iv
- input performance test
 - capacitance 2-41
 - coupling 2-32
 - resistance 2-44
 - return loss 2-55
 - trigger 2-34

installation 1-9

insufficient memory 2-12

interface

- HP-IB 1-16
- LAN (local area network) 1-14
- parallel 1-15
- serial 1 1-15

interface (continued)

- serial 2 1-7
- intermodulation distortion test 2-29

K

keyboard, connecting 1-18

L

LAN (local area network) 1-14

line voltage

- IF selector switch 1-10
- required 1-2
- RF selector switch 1-11
- linearity performance test 2-25
- LO spurs performance test 2-65
- loading performance test program 2-11

M

manual mode performance program 2-17

measurement uncertainty 2-7, 2-80

memory, insufficient 2-12

menu, performance test 2-75

minimum loss pad 1-19

model number

- IF section 1-10
- RF section 1-11

monitor, connecting external 1-17

N

noise performance test

- baseband 2-48
- phase 2-64
- RF 2-70
- source, RF 2-74

O

offset performance test 2-46

operating environment 1-9

operation verification

- confidence level 2-7
- test list 2-7

options, ordering iv

oven frequency reference

- connecting 1-7
- ordering optional iv

P

parallel port 1-15

performance test

- confidence level 2-7
- cycle 2-3
- list of 2-7

Index

- performance test (continued)
 - versus specification 2-9
- performance test program
 - controlled equipment 2-3
 - loading 2-11
 - manual mode 2-17
 - overview 2-2
 - semiautomated mode 2-13
 - softkey descriptions 2-75
 - without a printer 2-15
- phase performance test
 - channel match 2-27
 - noise 2-64
- plotter interface 1-15
- power
 - consumption 1-2
 - cords 1-3
 - turn on failure 1-22
- printer
 - interface 1-15
 - running program without 2-15
 - supported by program 2-3
- probe power iii
- problem
 - help with (*rear of manual*)
 - IF section will not power up 1-22
 - loading performance test program 2-12
 - RF section will not power up 1-23
 - stop frequency is 10 MHz 1-24
- program
 - See* performance test program

R

- recommended test equipment 2-3
- reference
 - connecting 1-7
 - ordering optional iv
 - performance test 2-69
- requirements
 - grounding 1-3
 - power 1-2
- residual responses performance test 2-47
- resistance performance test 2-44
- return loss
 - input performance test 2-55
 - source performance test 2-59
- RF performance test
 - amplitude accuracy 2-63
 - harmonic distortion 2-67
 - noise 2-70

- RF performance test (continued)
 - source amplitude accuracy 2-71
 - source distortion 2-73
 - source IF flatness 2-72
 - source noise 2-74
 - spurious signals 2-66
- RF section
 - connecting to IF section 1-7
 - fuse 1-13
 - model number 1-11
 - voltage selector switch 1-11
- running performance test program
 - manual mode 2-17
 - semiautomated mode 2-13
 - without printer 2-15

S

- safety
 - See* inside front cover
- screen, cleaning 1-20
- self test 2-18
- semiautomated performance test
 - See* performance test program
- serial
 - 1 port 1-15
 - 2 port 1-7
 - number (*rear of manual*)
- shipping 1-21
- softkey, performance test 2-75
- software
 - See* performance test program
 - version (*rear of manual*)
- source
 - connector iii
 - optional RF iv
- source performance test
 - amplitude accuracy 2-53
 - amplitude accuracy, RF 2-71
 - distortion 2-62
 - distortion, RF 2-73
 - flatness 2-72
 - noise 2-74
 - return loss 2-59
- specifications 2-9
- spurious performance test
 - LO 2-65
 - signals 2-47
 - signals, RF 2-66
- storage 1-20
- supplied accessories v
- system interconnect 1-16

Index

T

test

- duration 2-3
- equipment 2-3
- records, printing 2-3

ThinLAN port 1-14

transporting 1-21

trigger connector, external iii

trigger performance test

- external 2-36
- external arm 2-37
- input 2-34

U

uncertainty, measurement 2-7, 2-80

upgrading iv

V

verification

See operation verification

voltage selector switch

IF section 1-10

RF section 1-11

W

warm up time, performance test 2-69

wrong disk message 2-12

HP 89400-Series Documentation Roadmap

If you are thinking about...	And you want to...	Then read the analyzer's...
◆ Unpacking and installing the analyzer	Install the analyzer, or do operation verification or performance verification tests	<i>Installation and Verification Guide</i>
◆ Getting started	Make your first measurements with your new analyzer Review measurement concepts Learn what each key does	<i>Getting Started Guide</i> <i>Operator's Guide</i> Online Help (press the [Help] key)
◆ Making measurements	Learn how to make typical measurements	<i>Getting Started Guide and Operator's Guide</i>
◆ Creating automated measurements (To receive HP Instrument BASIC and HP Instrument BASIC manuals, order option 1C2)	Learn the HP Instrument BASIC interface Program with HP Instrument BASIC	<i>HP 89400-Series Using HP Instrument BASIC</i> <i>HP Instrument BASIC User's Handbook</i>
◆ Remote operation	Learn about the HP-IB and SCPI Find specific HP-IB commands quickly Find HP-IB command details	<i>HP-IB Programmer's Guide</i> <i>HP 89400-Series HP-IB Commands: Quick Reference</i> <i>HP 89400-Series HP-IB Command Reference</i>
◆ Using analyzer data with a PC application	Transfer analyzer data to or from a PC (Personal Computer) application Display analyzer data on a PC, or display PC data on the analyzer	<i>Standard Data Format Utilities: User's Guide</i>
◆ Servicing the analyzer (To receive service information, order option OB3)	Adjust, troubleshoot, or repair the analyzer	<i>Service Guide</i>

89441-90012

Declaration of Conformity

According to ISO/IEC Guide 22 and EN 45014

Manufacturer's name: Hewlett-Packard Company
Manufacturer's address: Lake Stevens Instrument Division
8600 Soper Hill Road
Everett, Washington 98205-1298

declares, that the product

Product Name: Vector Signal Analyzer
Model Number: HP 89440A

*conforms to the following specifications, except as noted in the
Product Specifications:*

Safety: IEC 348/HD401

EMC: CISPR 11: 1990/EN55011 (1991), Group1, Class A
IEC 801-2: 1991/EN50082-1 (1992): 4 kV CD, 8 kV AD
IEC 801-3: 1984/EN50082-1 (1992): 3 V/m
IEC 801-4: 1988/EN50082-1 (1992): 1 kV

Supplementary Information:

The product herewith complies with the requirements of the Low Voltage Directive 73/23/EEC and the EMC Directive 89/336/EEC.

Everett, Washington - November 30, 1992

Larry Bennett, Product Services Manager

Need Assistance?

If you need assistance, contact your nearest Hewlett-Packard Sales and Service Office listed in the HP Catalog, or contact your nearest regional office listed at the back of this guide. If you are contacting Hewlett-Packard about a problem with your HP 89440A Vector Signal Analyzer, please provide the following information:

- Model number: HP 89440A
- Firmware version: †
- IF section serial number: ‡
- RF section serial number: ‡
- Options:
- Date the problem was first encountered:
- Circumstances in which the problem was encountered:
- Can you reproduce the problem?
- What effect does this problem have on you?

† To display the firmware version, press [**System Utility**] [more] [firmware version].

‡ To display the serial number, press [**System Utility**] [more] [serial number].

About this edition

September 1995: In this edition, the title page was changed. The *Auto Performance Test* disk changed to revision A.02.03.

July 1995: In this edition, specifications for option AYH, Digital Video Modulation Analysis, were added to the HP 89440A Technical Data publication.

May 1995: In this edition, the title page was changed. The *Auto Performance Test* disk changed to revision A.02.02. Revision A.02.02 was designed for use with IF section firmware version A.03.00 and RF section firmware version A.00.01.

July 1994: In this edition, the “Specifications” chapter was replaced with the *HP 89440A Technical Data* publication. The *Auto Performance Test* disk changed to revision A.02.01. Revision A.02.01 was designed for use with IF section firmware version A.02.01 and RF section firmware version A.00.01.

November 1996: In this edition, the *Technical Data* publication was revised to reflect the following new features: adaptive equalization, extended arbitrary source lengths, and peak/average statistics.

HP 89441A

dc to 2.65 GHz

Vector Signal Analyzer

Technical Data

Specifications describe warranted performance over the temperature range of 0° to 55°C (except where noted) and include a 30-minute warm-up from ambient conditions, automatic calibrations enabled, auto-zero on, time domain calibration off, and anti-alias filter in, unless noted otherwise. Supplemental characteristics identified as “typical” or “characteristic,” provide useful information by giving non-warranted performance parameters. Typical performance is applicable from 20° to 30°C.

When enabled, automatic calibrations are periodically performed to compensate for the effects of temperature and time sensitivities. During the calibration, no signals >0 dBm should be connected to the front panel inputs.

Definitions

Baseband = dc to 10 MHz measurements.

Baseband time = Time-domain measurements selected by setting start frequency to exactly 0 Hz or choosing full span in 0 to 10 MHz measurements.

dBc = dB relative to input signal level.

dBfs = dB relative to full scale amplitude range setting. Full scale is approximately 2 dB below ADC overload.

Analog demodulation mode = Measurements with AM, PM, and FM demodulation capabilities.

FS or fs = Full scale; synonymous with amplitude range or input range.

RBW = Resolution bandwidth.

RF = 2 MHz to 2.65 GHz measurements.

Scalar mode = Measurements with only frequency-domain analysis available. Frequency spans up to 2648 MHz.

SNR = Signal to noise ratio.

Vector mode = Measurements with frequency- and time-domain capabilities. Frequency spans up to 10 MHz in baseband, and 7 MHz for RF analysis (8 MHz with option AYH).

Zoom time = Time-domain measurements selected by setting frequency parameters using center frequency and span values.

HP 89441A Technical Data

Standard Features

Standard Features

Frequency

dc to 2.650 GHz
51 to 3201 points
Center frequency signal-tracking

Instrument modes

Scalar (frequency-domain only)
Vector (amplitude and phase information in frequency- and time-domain and also time-gating)
Analog demodulation (AM/FM/PM)

Sweep types

Continuous Manual
Single

Triggering

Free run External
Input channel External arm
IF channel Programmable polarity and level
Internal source level
HP-IB Pre and post delay
Trigger holdoff

Averaging

Video Peak hold
Video exponential Simultaneous display of instantaneous and average spectrum
Time
Time exponential

Source types

CW Periodic chirp
Random noise Arbitrary (up to 8192 points)

Input

One channel
Second 10 MHz input channel (optional)
Auto-ranging (baseband only)
Overload indicators
50/75/1M Ω BNC (dc to 10 MHz)
50 Ω Type-N, 75 Ω with minimum-loss pad (2 MHz to 2650 MHz)

Resolution/window shapes

1-3-10 bandwidth steps
Arbitrary RBW
Windows: Flat-top (high amplitude accuracy), Gaussian-top (high dynamic range), Hanning (high frequency resolution), Uniform
Detectors: normal, positive peak, sample

Measurement data

Spectrum Time capture
PSD Frequency response, coherence, cross spectrum, and cross correlation (with second 10 MHz input channel)
Main time
Gate time
Math function
Data register
Auto correlation Instantaneous spectrum

Data format

Log magnitude Imaginary part
Linear magnitude Group delay
Phase (wrap or unwrap) Log/linear x-axis
Real part

Trace math

Display

1, 2, or 4 grids
1 to 4 traces displayed (single or overlay)
Auto-scaling
Color (user definable)
User trace title and information
Graticule on/off
Data label blanking
X-axis scaling
Instrument/Measurement state displays
External monitor

Markers

Marker search: Peak, next peak, next peak right, next peak left, minimum
Marker to: Center frequency, reference level, start frequency, stop frequency
Offset markers
Couple markers between traces
Marker functions: Peak track, frequency counter, band power (frequency, time, or demodulation results), peak/average statistics

Memory and data-storage

Disk devices
Nonvolatile RAM disk (100 Kbyte)
Volatile RAM disk (up to 1 Mbyte)
90 mm (3.5-inch) 1.44 Mbyte flexible disk (HP LIF or MS-DOS[®] formats)
External HP-IB disk
Disk format and file delete, rename, and copy
Nonvolatile clock with time/date
Save/recall of: Trace data, instrument states, trace math functions, HP Instrument BASIC programs, time-capture buffers

Online help

Hard copy output

HP-IB/HPGL plotters
HP-IB/RS-232/parallel printers
Plot to file
Time stamp
Single-plot spooling

Interfaces

HP-IB (IEEE 488.1 and 488.2)
External reference in/out
External PC-style keyboard
Active probe power
RS-232 (one port)
Centronics
LAN and second HP-IB (optional)

Standard data format utilities

Optional features

HP Instrument BASIC (option 1C2)
Vector modulation analysis (option AYA)
Digital video modulation analysis (option AYH)
Waterfall and spectrogram (option AYB)
Extended RAM and additional I/O (option UFG)
Advanced LAN support (option UG7)
Adaptive Equalization (option AYH or AYJ)

RF

RF specifications apply with the receiver mode set to "RF section (2-2650 MHz)."

Frequency

Frequency tuning

Frequency range	2 MHz to 2650 MHz
Frequency span	
Scalar mode	1 Hz to 2648 MHz
Vector mode	1 Hz to 7 MHz (8 MHz with option AYH)
Center frequency tuning resolution	0.001 Hz
Number of frequency points/span	51 to 3201
Signal track (when enabled) keeps the largest measured signal at the center frequency.	

Frequency accuracy (with standard high-precision frequency reference)

Frequency accuracy is the sum of initial accuracy, aging, and temperature drift.

Initial accuracy	± 0.1 ppm
Aging	± 0.015 ppm/month
Temperature drift	± 0.005 ppm (0° to 55°C)

Frequency counter

The frequency counter operates in scalar or vector mode.
 Frequency counter accuracy
 Total accuracy is the sum of the frequency counter's basic accuracy and the instrument's frequency accuracy.
 Conditions/Exceptions:

- Signal-to-noise ratio within resolution bandwidth, 20 dB minimum
- Marker within 1/2 resolution bandwidth of peak
- Unspecified for uniform window and resolution bandwidth < 5 Hz

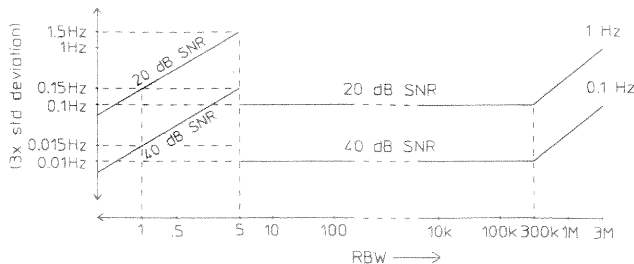

Frequency counter basic accuracy

Stability (spectral purity) (with standard high-precision frequency reference or equivalent with ≥ 5 dBm level)

Phase noise (absolute and residual)

$F_{in} \leq 200$ MHz

100 Hz offset	<- 103 dBc/Hz
1 kHz offset	<- 112 dBc/Hz
≥ 10 kHz offset	<- 116 dBc/Hz

200 MHz ≤ F_{in} ≤ 1 GHz

100 Hz offset	<- 96 dBc/Hz
1 kHz offset	<- 104 dBc/Hz
≥ 10 kHz offset	<- 116 dBc/Hz

1 GHz ≤ F_{in} ≤ 2650 MHz

100 Hz offset	<- 87 dBc/Hz
1 kHz offset	<- 97 dBc/Hz
≥ 10 kHz offset	<- 116 dBc/Hz

LO spurious sidebands

Offset > 1 kHz	<- 75 dBc
Offset ≤ 1 kHz	
$f_{in} \leq 2$ GHz	<- 70 dBc
$f_{in} > 2$ GHz	<- 68 dBc

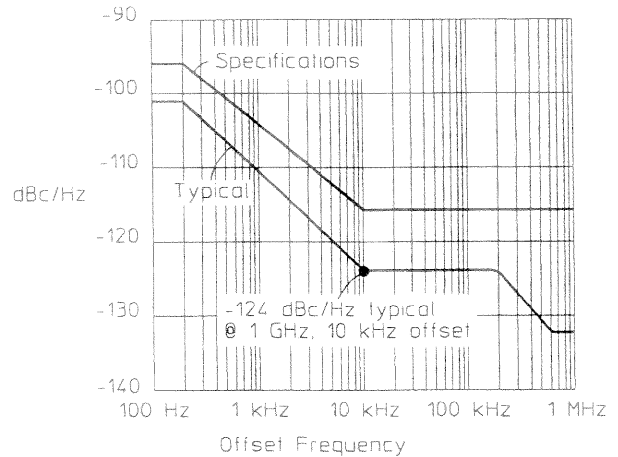

Spectral purity at 1 GHz

Resolution bandwidth

Range 312.5 μ Hz to 3 MHz in 1, 3, 10 sequence or arbitrary user-definable bandwidth

Note: In scalar mode, the minimum resolution bandwidth is 312.5 μ Hz and the maximum resolution bandwidth is a function of span. In vector mode, the minimum resolution bandwidth is a function of span and the number of frequency points, and the maximum resolution bandwidth is a function of span only.

Window	Selectivity†	Passband flatness	Sideband level
Flat-top	2.45:1	+ 0, - 0.01 dB	- 95 dBc
Gaussian-top	4.0:1	+ 0, - 0.68 dB	- 125 dBc
Hanning	9.1:1	+ 0, - 1.5 dB	- 32 dBc
Uniform	716:1	+ 0, - 4 dB	- 13 dBc

† Shape factor or ratio of - 60 dB to - 3 dB bandwidths.

Amplitude

Input range - 50 dBm to + 25 dBm (5 dB steps)

Maximum safe input power

Average + 25 dBm (300 mW)

continuous power

DC voltage 25 V

A/D overload level > 1.5 dB above range (typical)

Input port

Input channels 1

VSWR

Range \geq - 20 dBm 1.6:1 (12.7 dB return loss)

Range \leq - 25 dBm 1.8:1 (11 dB return loss)

Impedance 50 Ω (75 Ω with minimum-loss pad option 1D7)

Connector Type-N

Amplitude accuracy

Accuracy specifications apply with flat-top window selected.

Amplitude accuracy is the sum of absolute full-scale accuracy and amplitude linearity.

Absolute full-scale accuracy (with signal level equal to range)

	20° - 30°C	0° - 55°C
\geq - 25 dBm range	\pm 1 dB (0.5 dB typical)	\pm 2 dB
\leq - 30 dBm range	\pm 1.5 dB (0.5 dB typical)	\pm 3 dB

Amplitude linearity

0 to - 30 dBfs < 0.10 dB

- 30 to - 50 dBfs < 0.15 dB

- 50 to - 70 dBfs < 0.20 dB

In vector mode, relative level accuracy within a single span is the sum of vector mode frequency response and amplitude linearity.

Vector mode frequency response \pm 0.4 dB (relative to the center frequency)

Dynamic range

Dynamic range indicates the amplitude range that is free of erroneous signals within the measurement bandwidth.

Harmonic distortion (with a single full scale signal at the input)

≥ -25 dBm range	<- 75 dBc
≤ -30 dBm range	<- 54 dBc

Third-order intermodulation distortion (with two input tones at 6 dB below full scale and ≥ 10 MHz)

General spurious (with input signal level equal to range and input frequency ≤ 2650 MHz)

For spans ≤ 1.5 MHz and for offset frequencies ≤ 1.5 MHz from input signal <- 75 dBc

For all spans and offsets <- 70 dBc †

Residual responses (50 Ω input) <- 80 dBfs

Input noise density (50 Ω input, vector mode or scalar mode with sample detector) ‡

	20° - 30°C	0° - 55°C
≥ -25 dBm range	<- 115 dBfs/Hz	<- 112 dBfs/Hz
≤ -30 dBm range	<- 110 dBfs/Hz	<- 109 dBfs/Hz

Sensitivity‡

-50 dBm range	<- 160 dBm/Hz	<- 159 dBm/Hz
---------------	---------------	---------------

† <- 60 dBc for RF (2-2650 MHz)-wide (option AYH)

‡ Add 4 dB for RF (2-2650 MHz)-wide (option AYH)

Phase (vector mode)

Phase specifications apply with flat-top window selected.

Deviation from linear phase (relative to best fit line with peak signal level within 6 dB of full scale) ± 5 deg

Time (vector mode)

Time-sample resolution = 1/(k*span(Hz)) [second]; where k = 1.28 for zoom time.

Main time length = (number of frequency points - 1) ÷ span (Hz) [second]; for resolution bandwidth in arbitrary and auto-coupled mode.

Amplitude accuracy (for a sine wave in the measurement passband, time-domain calibrations on, range ≥ -25 dBm)

20° - 30°C	± 12% full scale (± 6% typical)
0° - 55°C	± 26% full scale

Sample error rate for zoom time (typical)

Error threshold: 10⁻⁸ times/sample
5% full scale

Sample error rate reflects the probability of an error greater than the error threshold occurring in one time sample.

Analog demodulation

Demodulation specifications apply with demodulation mode selected and time-domain calibration on.

AM, PM, or FM demodulation. Auto carrier locking is available with PM or FM demodulators and the carrier value determined is a displayable marker function.

Demodulator bandwidth (determined by selected measurement span)

Maximum bandwidth 7 MHz (typical)

AM demodulation (typical performance)

Accuracy ± 1%
 Dynamic range 60 dB (100%) for a pure AM signal
 Cross demodulation < 0.3% AM on an FM signal with 10 kHz modulation, 200 kHz deviation

PM demodulation (typical performance)

Accuracy ± 3 degrees
 Dynamic range 60 dB (rad) for a pure PM signal
 Cross demodulation < 1 degree PM on an AM signal with 80% modulation

FM demodulation (typical performance)

Accuracy ± 1% of span
 Dynamic range 60 dB (Hz) for a pure FM signal
 Cross demodulation < 0.5% of span FM on an AM signal with 80% modulation

Trigger

Trigger types

Scalar mode	Free run, internal source, HP-IB, external (each measurement step requires a separate trigger)
Vector mode	Free run, IF channel, internal source, HP-IB, external

Pre-trigger delay range (see time specifications for sample resolution)

One channel	64 Ksamples (1 Msample with extended time capture, option AY9)
Two channels (requires second 10 MHz input, option AY7)	32 Ksamples (0.5 Msample with extended time capture, option AY9)

Post-trigger delay range (see time specifications for sample resolution)

Trigger holdoff

When enabled, each measurement requires two trigger events. The first event starts a holdoff timer. After the specified holdoff time, a subsequent trigger event will initiate a measurement.

Holdoff resolution	2.5 μs
Holdoff range	2.5 μs to 41 s

IF trigger (characteristics only)

Used to trigger only on in-band energy, where the trigger bandwidth is determined by the measurement span (rounded to the next higher $10^7/2^n$ [Hz]).

Amplitude resolution < 1 dB

Amplitude ranges +1 to -70 dBfs. Useable range will become limited by the total integrated noise in the measurement span.

IF trigger hysteresis < 4 dB

External trigger (positive and negative slope)

Level accuracy	± 0.5 V
Range	± 5 V
Input impedance	10 kΩ (typical)

External arm

Level accuracy	± 0.5 V
Range	± 5 V
Input impedance	10 kΩ (typical)

Source (requires internal RF source option AY8)

Source types †
(vector mode) CW (fixed sine),
random noise,
periodic chirp,
arbitrary

Frequency

Range 2 MHz to 2650 MHz
Maximum offset from center frequency 3.5 MHz

Amplitude (fixed sine source type)

Amplitude range -40 dBm to +13 dBm
Typical maximum amplitude +17 dBm
(overdrive is available using
direct numeric entry)

Amplitude resolution 0.1 dB

Amplitude accuracy (source level \leq 13 dBm)

Source amplitude accuracy is the sum of absolute accuracy at the center frequency (zero offset frequency) and the IF flatness.

20° - 30°C 0° - 55°C

Absolute accuracy at the center frequency \pm 1.2 dB \pm 3.5 dB

IF flatness (relative to center frequency) \pm 1 dB \pm 1.5 dB

IF Flatness with \pm 0.3 dB
|offset frequency| \leq 500 kHz

Dynamic range (source level \leq 0 dBm)

Harmonic distortion $<$ - 40 dBc

Non-harmonic spurious $<$ - 40 dBc
(within measurement bandwidth)

Average noise level (for offsets $>$ 1 MHz from the carrier and carrier frequency $>$ 100 MHz. For offsets $<$ 1 MHz, add the LO phase noise.) $<$ - 120 dBc/Hz

Crosstalk (source-to-receiver, source level \leq 0 dBm) - 80 dBfs

Source port

VSWR

Level \leq - 10 dBm 1.8:1 (11 dB return loss)

Impedance

50 Ω (75 Ω with optional minimum-loss pad)

Connector

Type-N

† See Baseband section for random noise, periodic chirp, and arbitrary source characteristics.

Baseband

Baseband specifications apply with the receiver mode set to “IF section (0-10 MHz)” or “RF section (0-10 MHz)” unless noted otherwise. Specifications noted as “IF section only” apply with the receiver mode set to “IF section (0-10 MHz)” and the input signal connected directly to the IF section’s channel 1 or channel 2 input.

Frequency

Frequency tuning (characteristic only)

Frequency range	dc to 10 MHz
Frequency span	1.0 Hz to 10 MHz
Center frequency tuning resolution	0.001 Hz
Number of frequency points/span	51 to 3201
Signal track (when enabled) keeps the largest measured signal at the center frequency.	

Frequency accuracy

Same as the RF specifications.

Frequency counter

Same as the RF specifications.

Stability (spectral purity)

Absolute and residual phase noise, $F_{in} = 10$ MHz (with standard high precision frequency reference or equivalent)

100 Hz offset	<- 106 dBc/Hz
1 kHz offset	<- 110 dBc/Hz
≥10 kHz offset	<- 120 dBc/Hz

Phase noise decreases with decreasing input

$$\text{frequency by } 20 \log_{10} \left| \frac{F_{in}}{10 \text{ MHz}} \right| \text{ dB.}$$

Resolution bandwidth

Same as the RF specifications.

Amplitude

Input range (characteristic only)(2 dB steps)

50 Ω input	- 30 dBm to + 24 dBm
75 Ω input	- 31.761 dBm to +22.239 dBm
1 MΩ input	- 30 dBm to + 28 dBm
(referenced to 50 Ω)	

Maximum safe input power

50 Ω/75 Ω input	+ 27 dBm
1 MΩ input	20 V peak

Auto-ranging (characteristic only)

Up-only, up-down, single, off

Input port

Input channels	1 (second 10 MHz input channel optional)
Return loss (IF section only)	
50 Ω input	> 25 dB
75 Ω input	> 20 dB
Coupling	dc/ac (ac coupling attenuation < 3 dB at 3 Hz)
Input Impedance (IF section only)	50/75 Ω, 1 MΩ ± 2% (< 80 pF shunt capacitance)
Connector	BNC (RF section: Type-N)

Amplitude accuracy

Accuracy specifications apply with flat-top window selected.

Amplitude accuracy is the sum of absolute full-scale accuracy and amplitude linearity.

Absolute full-scale accuracy (IF section only, with signal level equal to range) ± 0.5 dB

Amplitude linearity

0 to - 30 dBfs	< 0.10 dB
- 30 to - 50 dBfs	< 0.15 dB
- 50 to - 70 dBfs	< 0.20 dB
Residual dc (50 Ω)	<- 25 dBfs

Dynamic range

Dynamic range indicates the amplitude range that is free of erroneous signals within the measurement bandwidth.

Harmonic distortion (with a single full scale signal at the input)

2nd	<- 75 dBc (- 80 dBc typical)
3rd, 4th, 5th	<- 75 dBc (- 85 dBc typical)

Intermodulation distortion (with two input tones at 6 dB below full scale)

Second-order	<- 75 dBc (- 80 dBc typical)
Third-order	<- 75 dBc (- 85 dBc typical)

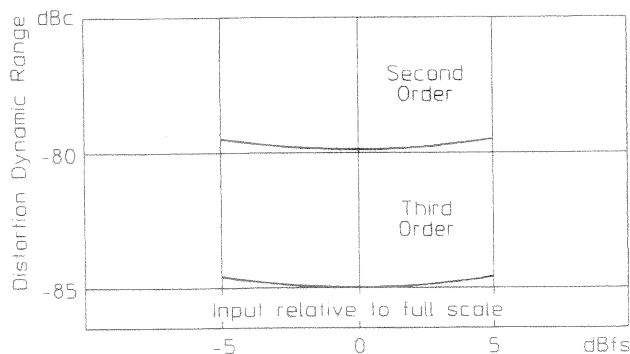

Typical harmonic and intermodulation distortion

Residual (spurious) responses (IF section only)
(50 Ω input and front panel connections to RF section disconnected)

Frequencies < 1 MHz <- 75 dBfs or <- 100 dBm whichever is greater

Frequencies ≥ 1 MHz <- 80 dBfs

Alias responses (for a single out-of-band tone at full scale) <- 80 dBfs

Input noise density (50 Ω input, vector mode or scalar mode with sample detector)

1 kHz to 40 kHz	<- 101 dBfs/Hz
40 kHz to 10 MHz	<- 114 dBfs/Hz (- 118 dBfs/Hz typical)

Sensitivity (- 30 dBm range, 50 Ω input, vector mode or scalar mode with sample detector)

1 kHz to 40 kHz	<- 131 dBm/Hz
40 kHz to 10 MHz	<- 144 dBm/Hz (- 148 dBm/Hz typical)

Crosstalk <- 85 dBfs
(source-to-input or channel-to-channel, 50 Ω terminations)

Phase (vector mode)

Phase specifications apply with flat-top window selected.

Deviation from linear phase ± 5 deg
(relative to best fit line with peak signal level within 6 dB of full scale)

Time (vector mode)

Time-sample resolution = 1/(k*span(Hz)) [second]; where k = 1.28 for zoom time, 2.56 for baseband time measurements.

Main time length = (number of frequency points - 1) ÷ span (Hz) [second]; for resolution bandwidth in arbitrary and auto-coupled mode.

Amplitude accuracy ± 5% full scale
(IF section only)(for a sine wave in the measurement passband, time-domain calibrations on)

Sample error rate for zoom time (typical)

Error threshold: 10^{-8} times/sample
5% full scale

Sample error rate reflects the probability of an error greater than the error threshold occurring in one time sample.

Analog channel-to-channel < 1 ns
time skew (IF section only)
(time-domain calibrations on, both channels on the same range)

Analog demodulation

Same as RF analog demodulation specifications except as noted below.

Demodulator bandwidth (determined by selected measurement span)

Maximum bandwidth 10 MHz (typical)

Two-channel

The second 10 MHz input channel (option AY7) provides additional measurements, including frequency response, coherence, cross spectrum, and cross correlation. These measurements are made by comparing a signal on channel two to a signal on channel one or to a demodulated signal on the RF input.

Channel match ± 0.25 dB, ± 2.0 deg
(IF section only, at the center of the frequency bins, dc coupled, 16 rms averages, frequency response, full scale inputs, both inputs on the same range. Exclude the first 5 bins of the dc response.)

Trigger

Same as RF trigger specifications with the following additional specifications.

Input channel trigger (positive and negative slope)

Level accuracy $\pm 10\%$ full scale
Range $\pm 110\%$ full scale
Resolution Full scale/116 (typical)

Source (with output filter on)

Source types

Scalar mode CW (fixed sine), arbitrary
Vector mode CW, random noise, periodic chirp, arbitrary

Random noise source % of energy in-band $> 70\%$
(Span = $10 \text{ MHz}/2^N$, $N = 1$ to 24)
Periodic chirp source % of energy in-band $> 85\%$

Frequency

Frequency range dc to 10 MHz
Frequency resolution 25 μ Hz

Amplitude

Source level

CW and random noise $- 110$ dBm to $+ 23.979$ dBm (50 Ω),
5.0 Vpk maximum
Periodic chirp and arbitrary $- 110$ dBm to $+ 19.542$ dBm (50 Ω),
3.0 Vpk maximum
DC offset ± 3.42 V maximum (resolution and range of programmable dc offset is dependent on source amplitude)

Amplitude accuracy (50 Ω , fixed sine)
(IF section only)

$- 46$ dBm to $+ 24$ dBm ± 1.0 dB
 $- 56$ dBm to $- 46$ dBm ± 2.0 dB

Harmonic and other spurious products (fixed sine, 0 V dc offset)

dc to 10 kHz $< - 55$ dBc
10 kHz to 5 MHz $< - 40$ dBc
5 MHz to 10 MHz $< - 33$ dBc

Source port

Return loss (IF section only) > 20 dB
Source impedance 50/75 Ω

Arbitrary source characteristics

The arbitrary source repetitively outputs data stored in a data register. The data register may contain a single time record or, with option AYB, a trace buffer. The time length of the register depends on the time-sample resolution for the span entered when the data register was saved or created. See time specifications for time-sample resolution details.

Arbitrary source length

Single time record Up to 4096 complex or 8192 real points.

Trace buffer (requires option AYB) Up to 16,384 real or complex points. Some configurations allow up to 32,768 real or complex points (see the *Operator's Guide* for details)

General

Safety and environmental

Safety standards	CSA Certified for Electronic Test and Measurement Equipment per CSA C22.2, No. 231
This product is designed for compliance to	UL1244 and IEC348, 1978
Acoustics	LpA < 55 dB typical at 25°C ambient (Temperature controlled fan to reduce noise output)
Temperature	
Operating	0° to 55°C
Internal disk operations	4° to 40°C
Storage (no disk in drive)	- 20° to 65°C
Humidity, non-condensing	
Operating	10% to 90% at 40°C
Internal disk operations	20% to 80% at 30°C
Storage (no disk in drive)	10% to 90% at 40°C
Altitude	
Operating (above 2285 m (7,500 ft), derate operating temperature by - 3.6°C/1000 m (- 1.1°C/1000 ft))	4600 m (15,000 ft)
Storage	4600 m (15,000 ft)
Calibration interval	1 year
Warm-up time	30 minutes
Power requirements	
115 VAC operation	
IF section	90 - 140 Vrms, 47 - 440 Hz
RF section	90 - 140 Vrms, 47 - 63 Hz
230 VAC operation	198 - 264 Vrms, 47 - 63 Hz
Maximum power dissipation	
IF section	750 VA
RF section	275 VA

IEC 801-3 (Radiated Immunity) Performance degradation may occur at Severity Level 2.

Physical

Weight	IF section	25 kg (55 lb)
	RF section	25 kg (55 lb)
Dimensions		
IF section	Height	230 mm (9.1 in)
	Width	426 mm (16.7 in)
	Depth	530 mm (20.9 in)
RF section	Height	173 mm (6.8 in)
	Width	419 mm (16.5 in)
	Depth	495 mm (19.5 in)

Real time bandwidth (characteristics only)

Real-time bandwidth is the maximum frequency span that can be continually analyzed without missing any time segment of the input signal.

Frequency spans of $10^7/2^n$ Hz, arbitrary auto-coupled resolution bandwidth, markers off, one display trace with calculations off on other traces, and maximum frequency points equal to number of frequency points.

Averaging off

Single-channel vector mode (log magnitude spectrum measurement data, 1601 frequency points, channel 2 off, averaging off)	78.125 kHz, 48 updates/second
Two-channel vector mode (requires second 10 MHz input channel, option AY7) (Log magnitude frequency response measurement data, 801 frequency points, averaging off)	39.0625 kHz, 48 updates/second

Averaging

Single-channel vector mode averaging
(log magnitude spectrum measurement data, 1601 frequency points, channel 2 off)

Fast average	78.125 kHz
Displayed	78.125 kHz, 48 updates/second

Two-channel vector mode averaging (requires second 10 MHz input channel, option AY7) (Log magnitude frequency response measurement data, 801 frequency points)

Fast average	39.0625 kHz
Displayed	39.0625 kHz, 48 updates/second

Demodulation

Single-channel analog demodulation mode (log magnitude spectrum measurement data, 1601 frequency points, time cal off, channel 2 off, averaging off)

AM demodulation	19.53125 kHz
FM or PM demodulation	9.765625 kHz

Measurement speed

Display update speed (vector mode with full span, one or two channels, 401 frequency points, no averaging, markers off, single trace with calculations off on other traces, log magnitude spectrum, frequency spans of $10^7/2^n$ Hz): 60/second

Averaging (characteristics only)

Number of averages	1 to 99,999
Overlap averaging	0% to 99.99%
Average types	
Scalar mode	rms (video), rms (video) exponential, peak hold
Vector mode	rms (video), rms (video) exponential, time, time exponential, peak hold

Fast averaging allows averaging a user-defined number of measurements without updating the displayed result. This provides faster averaging results for most measurements.

Gating (characteristics only)

Time-selective, frequency-domain analysis can be performed on any input or analog demodulated time-domain data. When gating is enabled, markers appear on the time data; gate length and delay can be set directly. Independent gate delays can be set for each input channel. See time specifications for main time length and time resolution details.

Gate length

Maximum: Main time length

Minimum: Approximately window shape ÷ (0.3 × span (Hz)) [seconds]; where window shape (ws) and minimum gate length for a 10 MHz zoom time span are (for 10 MHz baseband time spans subtract 39.0625 ns):

Window	ws	Minimum gate length
Flat-top	3.819	1.328125 μs
Gaussian-top	2.215	781.25 ns
Hanning	1.5	546.875 ns
Uniform	1.0	390.625 ns

Time-capture (characteristics only)

Direct capture of input waveforms can be accomplished with spans of 10 MHz/2ⁿ Hz. See time specifications for time-sample resolution details.

Time capture memory: 64 Ksample; 1 Msample (option AY9)

Benchmarks: For a one-channel, zoom time measurement (for baseband time, halve the time), 64 Ksample captures from 5.12 ms in a 10 MHz span to over 11.9 hours in a 1.19 Hz span. The optional 1 Msample captures from 81.92 ms in a 10 MHz span to over 190 hours in a 1.19 Hz span. Memory is shared if two channels are enabled, therefore length of capture is half as long.

Band power marker (characteristics only)

Markers can be placed on any time, frequency, or demodulated trace for direct computation of band power, rms square root (of power), C/N, and C/N₀ within the selected portion of the data.

Peak/Average Statistics

Peak and peak-to-average statistics can be enabled on main time, gate time, IQ measured time (AYA), IQ reference time (AYA), and math functions involving these trace types. Average power and peak statistics are computed using all samples in the active trace. Each successive trace adds additional samples to the calculations.

Displayed Results	average power peak power peak/average ratio number of samples
Peak Percent	90% – 99.99%. Setting can be changed at any time during or after the measurement.
Signal characteristics	
Peak power range	+ 13 dB relative to average power of the first time record
Average power range	± 3 dB relative to average power of the first time record.

Display (characteristic only)

Trace formats	One to four traces on one, two, or four grids or a quad display
Other displays	On-line help text, view state
Number of colors	User-definable palette
Display points/trace	401
User-definable trace titles	titles and information
X-axis scaling	Allows expanded views of portions of the trace information
Display blanking	Data or full display
Graticule on/off	
Center	± 5 mm referenced to bezel opening
Dimensions	
Height	105 ± 5 mm
Width	147 ± 5 mm
Diagonal	180.6 mm (7.1 in)

Status indicators

Overload, half range, external trigger, source on/off, trigger, pause, active trace, remote, talk, listen, SRQ.

External PC-style keyboard interface

Compatible with PC-style 101-key keyboard, such as the HP C1405B with HP C1405-60015 adapter.

HP 89441A Technical Data

General

Interfaces (characteristics only)

Active probe power	+15 Vdc, -13 Vdc; 150 mA maximum, compatible with HP active probes
Sync out	Active low TTL level signal synchronous with source output of periodic chirps and arbitrary blocks up to 8192 samples.
External reference in/out IF section	
External reference input	Locks to a 1, 2, 5, or 10 MHz (± 10 ppm) with a level > 0 dBm
External reference output	Output the same frequency as the external reference input at a level of > 0 dBm into a 50Ω load.
External reference in/out RF section	
External reference input	Locks to a 1, 2, 5, or 10 MHz (± 10 ppm) with a level > 0 dBm (use ≥ 5 dBm for optimum phase noise performance).
External reference output	Outputs 10 MHz at > 0 dBm (+6 dBm typical) into a 50Ω load.

HP-IB

Implementation of IEEE Std 488.1 and 488.2
SH1, AH1, T6, TE0, L4, LE0, SR1, RL1, PP0, DC1,
DT1, C1, C2, C3, C12, E2

Benchmark characteristics (typical transfer rate of 401 frequency-point traces)

Scalar	25 traces/second
Vector	20 traces/second
RS-232	Serial port (9-pin) for connection to printer
Centronics	Parallel port for connection to a printer

External monitor output

Format	Analog plug-compatible with 25.5 kHz multi-sync monitors
Impedance	75Ω
Level	0 to 0.7 V
Display rate	60 Hz
Horizontal refresh rate	25.5 kHz
Horizontal lines	400

Optional interfaces

Option UFG includes the following interfaces

Second HP-IB	Implementation of IEEE Std 488.1 and 488.2
LAN	ThinLAN BNC

Peripherals

Plot/print

Direct plotting and black-and-white printing to parallel (Centronics), serial (RS-232), and HP-IB graphics printers and plotters. Printers supported include the HP LaserJet, HP PaintJet, HP ThinkJet, HP DeskJet, and HP QuietJet. Single-plot spooling allows instrument operation while printing or plotting a single display.

Memory and data storage

Disk devices

Nonvolatile RAM disk	100 Kbyte
Volatile RAM disk	1 Mbyte that can be partitioned between measurement, HP Instrument BASIC program space and RAM. Volatile RAM also supports memory of waterfalls and spectrograms with option AYB.

Internal 90 mm (3.5-inch) flexible disk (HP LIF or MS-DOS® formats)

1.44 Mbyte
HP-IB interface

Disk format and file delete, rename and copy

Nonvolatile clock with time/date

Save/recall can be used to store trace data, instrument states, trace math functions, HP Instrument BASIC programs, and time-capture buffers.

Benchmarks (typical disk space requirements for different file types)

Trace data (401 points)	6.2 Kbyte
Instrument state	12.3 Kbyte
Trace math	2 Kbyte
Time-capture buffers (32 Ksamples)	271 Kbyte

Optional extended RAM Option UFG includes 4 Mbyte additional RAM for expanding the volatile RAM capabilities listed earlier.

Trace math

Operands measurement data, data register, constant, other trace math functions, jw

Operations +, -, *, /, cross correlation, conjugate, magnitude, phase, real, imaginary, square root, FFT, inverse FFT, natural logarithm, exponential

Trace math can be used to manipulate data on each measurement. Uses include user-units correction and normalization.

Marker functions

Peak signal track, frequency counter, band power, peak/average statistics.

Standard data format utilities

Included on two 90 mm (3.5-inch) 1.44 Mbyte flexible disks and two 130 mm (5.25-inch) 1.2 Mbyte floppy disks. The utilities run in MS-DOS® 2.1 or greater on an IBM PC (AT or higher) or compatible. The utilities include conversions to standard data format (SDF), PC displays of data and instrument state information, and utilities for conversion to PC-MATLAB, MATRIX_x, data set 58 and ACSII formats.

Options

**Vector Modulation Analysis —
Option AYA**

Supported modulation formats

The vector modulation analysis option supports both single modulated carriers and separate baseband I-Q signals. The optional second 10 MHz input channel is required for baseband I and Q analysis.

Carrier types	Continuous and pulsed/burst (such as TDMA)
Modulation formats	2 level FSK (including GFSK) 4 level FSK MSK (including GMSK) QAM implementations of: BPSK, QPSK, OQPSK, DQPSK, $\pi/4$ DQPSK, 8PSK, 16QAM, 32QAM
Default parameter settings †	NADC, PDC (JDC), GSM, PHS, DECT, CDPD, TETRA, CDMA Base, CDMA Mobile

Filtering

All filters are computed to 20 symbols in length

Filter types	Raised cosine Square-root raised cosine IS-95 compatible Gaussian None Rectangular Low pass
User-selectable filter parameters	Alpha/BT continuously adjustable from 0.05 to 10
User-defined filters	User-defined impulse response, fixed 20 points/symbol Maximum 20 symbols in length or 401 points

Frequency and symbol rate

Receiver mode	Information bandwidth
ch1 + j*ch2	≤ 20 MHz‡
0 - 10 MHz	≤ 10 MHz
2 - 2650 MHz	≤ 7 MHz
2 - 2650 MHz - wide	≤ 8 MHz (option AYH only)
External	≤ 8 MHz (HP 89411A only)

†NADC and CDMA preset settings require option UFG.

‡ Two-channel measurements such as ch1 + j*ch2 require option AY7 second 10 MHz input channel.

Symbol Rate

Symbol Rate is limited only by the information bandwidth

$$\text{Symbol Rate} = \frac{\text{Bits/Second}}{\text{Bits/Symbol}}$$

Where bits/symbol is determined by the modulation type. Example: For the raised-cosine filter

$$\text{Max Symbol Rate} \leq \frac{\text{Information Bandwidth}}{1 + \alpha}$$

Measurement results (formats other than FSK)

Display update rate

Conditions: NADC preset, 50 kHz span, result length 150 symbols, 1 point/symbol. IQ envelope triggering and data synchronization off.

Update rate >2 per second (characteristic only)

I-Q measured Time, spectrum
(Filtered, carrier locked, symbol locked)

I-Q reference Time, spectrum
(Ideal, computed from detected symbols)

I-Q error vs. time Magnitude, phase
(I-Q measured vs. reference)

Error vector Time, spectrum
(Vector error of computed vs. reference)

Symbol table + Error vector magnitude is
error summary computed at symbol times only

Measurement results (FSK)

FSK measured	Time, spectrum
FSK reference	Time, spectrum
Carrier error	Magnitude
FSK error	Time, spectrum

Display formats

The following trace formats are available for measured data and computed ideal reference data, with complete marker and scaling capabilities and automatic grid line adjustment to ideal symbol or constellation states.

Polar diagrams

Constellation: Samples displayed only at symbol times

Vector: Display of trajectory between symbol times with 1 to 20 points/symbol

I or Q vs time

- Eye diagrams: Adjustable from 0.1 to 10 symbols
- Trellis diagrams: Adjustable from 0.1 to 10 symbols

Continuous error vector magnitude vs. time

Continuous I or Q vs. time

Error summary (formats other than FSK)

Measured rms and peak values of the following:

- Error vector magnitude
- Magnitude error
- Phase error

Frequency error (carrier offset frequency)

I-Q offset

Amplitude droop (formats other than QAM)

SNR (QAM formats)

Error summary (FSK)

Measured rms and peak values of the following:

- FSK error
- Magnitude error
- Carrier offset frequency
- Deviation

Detected bits (symbol table)

Binary bits are displayed and grouped by symbols. Multiple pages can be scrolled for viewing large data blocks.

Symbol marker (current symbol shown as inverse video) is coupled to measurement trace displays to identify states with corresponding bits.

For formats other than FSK and MSK, bits are user-definable for absolute states or differential transitions. Note: Synchronization words are required to resolve carrier phase ambiguity on non-differential modulation formats.

Accuracy (formats other than FSK and IS-95 CDMA)

Conditions: Specifications apply from 20° to 30°C, for a full-scale signal fully contained in the selected measurement span, random data sequence, instrument receiver mode of IF 0-10 MHz or RF 2-2650 MHz, range ≥ -25 dBm, start frequency $\geq 15\%$ of span, $\alpha/BT \geq 0.3$ †, and symbol rate ≥ 1 kHz. For symbol rates less than 1 kHz, accuracy may be limited by phase noise.

Residual errors (result length = 150 symbols, averages = 10)

Error vector magnitude

Freq span ≤ 100 kHz	0.3 % rms
Freq span ≤ 1 MHz	0.5 % rms
Freq span > 1 MHz	1.0 % rms

Magnitude error

Freq span ≤ 100 kHz	0.3 % rms
Freq span ≤ 1 MHz	0.5 % rms
Freq span > 1 MHz	1.0 % rms

Phase error (For modulation formats with equal symbol amplitudes.)

Freq span ≤ 100 kHz	0.17°rms
Freq span ≤ 1 MHz	0.34°rms
Freq span > 1 MHz	0.57°rms

Frequency error

Symbol rate/500,000
(Added to frequency accuracy if applicable.)

Origin/I-Q Offset - 60 dB

Accuracy (2 FSK and 4 FSK)

Residual errors, typical

4 FSK or 2 FSK, symbol rate = 3.2 kHz, deviation = 4.8 kHz, instrument receiver mode of IF 0-10 MHz or RF 2-2650 MHz, 50 kHz span, full-scale signal, range ≥ -25 dBm, result length = 150, averages = 10, tenth-order Bessel filtering with 3 dB bandwidth = 3.9 kHz. ‡

FSK error	0.5 % rms
Magnitude error	0.3 % rms
Deviation	± 0.3 % rms (14 Hz)
Carrier frequency offset	± 0.3 % of deviation
(Added to frequency accuracy if applicable)	

DECT preset (2 FSK, symbol rate = 1.152 MHz, BT = 0.5) 288 kHz deviation, instrument receiver mode of IF 0-10 MHz or RF 2-2650 MHz, 4 MHz span, full-scale signal, result length = 150, averages = 10.

FSK error	1.5 % rms
Magnitude error	1.0 % rms
Deviation	± 1.0 % rms (2.88 kHz)
Carrier frequency offset	± 0.5 % of deviation
(Added to frequency accuracy if applicable)	

‡ Note: For error analysis, a Gaussian reference filter with BT = 1.22 is used to approximate the tenth-order Bessel filter.

† $0.3 \leq \alpha \leq 0.7$ for Offset QPSK

HP 89441A Technical Data

Options

Accuracy (IS-95 CDMA)

CDMA Base or CDMA Mobile preset, instrument mode of IF (0 – 10 MHz) or RF (2 – 2650 MHz), 2.6 MHz span, full scale signal, result length=200, averages=10.

Residual Errors

Error vector magnitude	1% rms
Magnitude error	1% rms
Phase error	0.57° rms
Frequency error	10 Hz
(Added to frequency accuracy if applicable.)	
Origin I/Q offset	– 60 dB

Signal Acquisition

Note: Signal acquisition does not require an external carrier or symbol clock

Data block length

Adjustable up to 1024 samples (4096 samples with extended RAM option UFG).

Examples (with option UFG):

4096 symbols at 1 point/symbol;

409 samples at 10 points/symbol.

Symbol clock Internally generated

Carrier lock Internally locked

Triggering

Single/continuous

External

Internal source

Pulse search (searches data block for beginning of TDMA burst, and performs analysis over selected burst length)

Data synchronization

User-selected synchronization words

Arbitrary bit patterns up to 30 symbols long, at any position in a continuous or TDMA burst and measurement result. Up to 6 words can be defined.

Arbitrary waveform source

RAM-based arbitrary waveforms

Waveform registers	Maximum 6
Waveform length	4096 Complex points each (16,384 with option AYB)

Residual accuracy, typical

Examples

$\pi/4$ DQPSK, 24.3 ksymbols/second,
 $\alpha = 0.35$ EVM $\leq 0.7\%$ rms

GMSK, 270.833 ksymbols/second,
BT= 0.30 EVM $\leq 1.0\%$ rms

Digital Video Modulation Analysis — Option AYH (requires option AYA)

This option extends the capabilities of the vector modulation analysis option AYA by adding modulation formats used for digital video transmission. Except where noted, all of the standard capabilities of option AYA are provided for the new modulation formats.

Supported modulation formats

Additional modulation formats	8 and 16VSB 16, 32, 64 and 256QAM 16, 32, and 64QAM (differentially encoded per DVB standard)
-------------------------------	--

Frequency span

The (2–2650 MHz)-wide receiver mode increases the maximum allowable vector frequency span to 8 MHz. Specifications for this mode are in the RF specification section.

Maximum symbol rate

Option AYH analyzes vector modulated signals up to a maximum symbol rate determined by the information bandwidth of the receiver mode and the excess bandwidth factor (α) of the input signal, according to:

$$\text{Max Symbol Rate} \leq \frac{\text{Information Bandwidth}}{1 + \alpha}$$

(Note: the maximum symbol rate is doubled for VSB signals.)

Receiver mode	Information bandwidth
ch1 + j*ch2	≤ 20 MHz †
0 - 10 MHz	≤ 10 MHz
2 - 2650 MHz - normal	≤ 7 MHz
2 - 2650 MHz - wide	≤ 8 MHz
External	≤ 10 MHz †

Example: For a 64QAM signal ($\alpha = 0.15$), the maximum symbol rate for the (2-2650 MHz)-wide receiver is $8 \text{ MHz}/(1.15) = 6.96 \text{ Msymbols/second}$.

Measurement results and display formats.

Identical to option AYA measurement results and display formats except for the following changes to the error summary display:

VSB pilot level is shown, in dB relative to nominal.

For VSB formats, SNR is calculated from the real part of the error vector only.

For DVB formats, EVM is calculated without removing IQ offset.

Accuracy

Residual errors (typical)

8VSB or 16VSB, symbol rate = 10.762 MHz,
 $\alpha = 0.115$, instrument receiver mode of IF 0-10 MHz or RF 2-2650 MHz, 7 MHz span, full-scale signal, range ≥ -25 dBm, result length = 800, averages = 10.

Residual EVM $\leq 1.5\%$ (SNR ≥ 36 dB)

16, 32, 64 or 256 QAM, symbol rate = 6.9 MHz,
 $\alpha = 0.15$, instrument receiver mode of IF 0-10 MHz or RF 2-2650 MHz-wide, 8 MHz span, full-scale signal, range ≥ -25 dBm, result length = 800, averages = 10.

Residual EVM $\leq 1.0\%$ (SNR ≥ 40 dB)

† Downconverter dependent.

Filtering

All option AYA filter types are supported except user-defined filters for VSB analysis. Filters are calculated to 40 symbols in length.

Triggering and Synchronization

All option AYA signal acquisition features are supported except pulse and sync word search for VSB analysis.

Adaptive Equalization — Option AYH or Option AYJ (AYJ adds adaptive equalization to option AYA)

This option equalizes the digitally-modulated signal to remove effects of linear distortion (such as unflatness and group delay) in a modulation quality measurement.

Equalizer performance is a function of the filter design (e.g., length, convergence, taps/symbol) and the quality of the signal being equalized.

Equalizer

Decision-directed, LMS, feed-forward equalization with adjustable convergence rate.

Filter length 3–99 symbols, adjustable

Filter taps 1,2,4,5,10, or 20 taps/symbol

Measurement results

Equalizer impulse response

Channel frequency response

Supported modulation formats

MSK, BPSK, QPSK, OQPSK, DQPSK, $\pi/4$ DQPSK, 8 PSK, 16 QAM, 32 QAM, 64 QAM, 256 QAM, 8 VSB, 16 VSB

Waterfall and Spectrogram — Option AYB

Waterfall

Types	Vertical and skewed — Azimuth adjustable 0 to ± 45 Normal and hidden line With or without baseline.
Adjustable parameters	Trace height Buffer depth Elevation Threshold

Spectrogram

Types	Color, normal and reversed Monochrome, normal and reversed User color maps (2 total)
Adjustable parameters	Number of colors Enhancement (color-amplitude weighting) Threshold

Trace select

When a waterfall or spectrogram measurement is paused or completed, any trace in the trace buffer can be selected by trace number or by z-axis value. The marker values and marker functions apply to the selected trace.

Z-axis value

The z-axis value is the time the trace data was acquired relative to the start of the measurement. The z-axis value of the selected trace is displayed as part of the marker readout.

Display update rate 30 to 60/second, typical

System memory (characteristic only)

Note: In standard configuration, the analyzer has approximately 1-2 Mbytes of free memory for these displays. Option UFG adds 4 Mbytes of free memory.

Memory required (characteristic only)

Displays occupy memory at the rate of 175 traces/Mbyte (for traces of 401 frequency points).

A full screen of 307 traces will require 2.25 Mbytes of free memory.

With option UFG, the analyzer will typically accommodate more than 1000 traces in memory.

4 Mbytes Extended RAM and Additional I/O — Option UFG

Extended RAM

Extended memory type: 4 Mbytes dynamic RAM
Available memory with option UFG installed:
Approximately 6 Mbytes, user-allocatable to
measurement memory, RAM disk and IBASIC
program space.

LAN I/O

LAN support: Ethernet (IEEE 802.3) TCP/IP

LAN interface: ThinLAN (BNC connector) or AUI

Recommended MAU: HP 28685B (10base-T) or
HP 28683A (FDDI)

Program interface: Send and receive HP-IB
programming codes, status bytes and measurement
results in ASCII and/or binary format.

HP-IB I/O

Secondary HP-IB port: Per IEEE Std 488.1 and 488.2

Functions: Controller-only; accessible from IBASIC
program or front panel commands.

Note: Option UFG is strongly recommended for use
with option AYA Vector Modulation Analysis and
option AYB Waterfall and Spectrogram.

Advanced LAN Support — Option UG7

Remote X11 display (characteristic only)

Update rate: > 20 per second, depending on
workstation performance and LAN activity.

X11 R4 compatible

X-terminals, UNIX workstations, PC with X-server
software

Display: 640 × 480 pixel minimum resolution
required; 1024 × 768 recommended.

FTP data (characteristic only)

Traces A, B, C, D

Data registers D1-D6

Time capture buffer

Disk files (RAM, NVRAM, floppy disk)

Analyzer display plot/print

Note: Option UG7 requires option UFG.

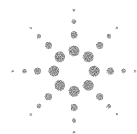

Agilent Technologies