



Agilent Technologies

Innovating the HP Way

June 8, 2000

Dear Customer,

As of November 1, 1999, four of Hewlett-Packard's businesses, test and measurement, semiconductor products, health care solutions, and chemical analysis became a new company, Agilent Technologies. Now, many of your Hewlett-Packard products and services are in the care of Agilent Technologies.

At Agilent Technologies, we are working diligently to make this transition as smooth as possible for you. However, as a result of this transition, the products and related documentation contained in this shipment may be labeled with either the Hewlett-Packard name and logo, the Agilent Technologies name and logo, or a combination of both. Information in this package may refer to Hewlett-Packard (HP), but applies to your Agilent Technologies product. Hewlett-Packard and Agilent branded products with the same model number are interchangeable.

Whatever logo you see, the information, products, and services come from the same reliable source.

If you have questions about Agilent Technologies products and services, please visit our website at <http://www.agilent.com>.

Sincerely,

Rebranding Team

HP 8903B AUDIO ANALYZER (Including Option 001)

Operation and Calibration Manual

SERIAL NUMBERS

This manual applies directly to instruments with serial numbers prefixed:

2450A to 2922A and all *Major* changes that apply to your instrument.

rev.20JUN91

For additional important information about serial numbers, refer to "INSTRUMENTS COVERED BY THIS MANUAL" in Section 1.

Fourth Edition

This material may be reproduced by or for the U.S. Government pursuant to the Copyright License under the clause at DFARS 52.227-7013 (APR 1988).

Copyright ©HEWLETT-PACKARD COMPANY 1985
EAST 24001 MISSION AVENUE, TAF C-34, SPOKANE, WASHINGTON, U.S.A. 99220

Operation and Calibration Manual HP Part 08903-90079

Other Documents Available:

Service Manual (Volume 1, 2) HP Part 08903-90062

Microfiche Operation and Service Manual HP Part 08903-90080

Printed in U.S.A. : November 1989



1 Regulatory Information

(Updated March 1999)

Safety Considerations

GENERAL

This product and related documentation must be reviewed for familiarization with safety markings and instructions before operation.

This product has been designed and tested in accordance with *IEC Publication 1010*, "Safety Requirements for Electronic Measuring Apparatus," and has been supplied in a safe condition. This instruction documentation contains information and warnings which must be followed by the user to ensure safe operation and to maintain the product in a safe condition.

SAFETY EARTH GROUND

A uninterruptible safety earth ground must be provided from the main power source to the product input wiring terminals, power cord, or supplied power cord set.

SAFETY SYMBOLS



Indicates instrument damage can occur if indicated operating limits are exceeded.



Indicates hazardous voltages.



Indicates earth (ground) terminal

WARNING **A WARNING note denotes a hazard. It calls attention to a procedure, practice, or the like, which, if not correctly performed or adhered to, could result in personal injury. Do not proceed beyond a WARNING sign until the indicated conditions are fully understood and met.**

CAUTION **A CAUTION note denotes a hazard. It calls attention to an operation procedure, practice, or the like, which, if not correctly performed or adhered to, could result in damage to or destruction of part or all of the product. Do not proceed beyond an CAUTION note until the indicated conditions are fully understood and met.**

Safety Considerations for this Instrument

WARNING This product is a Safety Class I instrument (provided with a protective earthing ground incorporated in the power cord). The mains plug shall only be inserted in a socket outlet provided with a protective earth contact. Any interruption of the protective conductor inside or outside of the product is likely to make the product dangerous. Intentional interruption is prohibited.

Whenever it is likely that the protection has been impaired, the instrument must be made inoperative and be secured against any unintended operation.

If this instrument is to be energized via an auto transformer (for voltage reduction), make sure the common terminal is connected to the earth terminal of the power source.

If this product is not used as specified, the protection provided by the equipment could be impaired. This product must be used in a normal condition (in which all means for protection are intact) only.

No operator serviceable parts in this product. Refer servicing to qualified personnel. To prevent electrical shock, do not remove covers.

Servicing instructions are for use by qualified personnel only. To avoid electrical shock, do not perform any servicing unless you are qualified to do so.

The opening of covers or removal of parts is likely to expose dangerous voltages. Disconnect the product from all voltage sources while it is being opened.

The power cord is connected to internal capacitors that may remain live for 5 seconds after disconnecting the plug from its power supply.

For Continued protection against fire hazard, replace the line fuse(s) only with 250 V fuse(s) or the same current rating and type (for example, normal blow or time delay). Do not use repaired fuses or short circuited fuseholders.

Always use the three-prong ac power cord supplied with this product. Failure to ensure adequate earth grounding by not using this cord may cause product damage.

This product is designed for use in Installation Category II and Pollution Degree 2 per IEC 1010 and IEC 664 respectively. FOR INDOOR USE ONLY.

This product has autoranging line voltage input, be sure the supply voltage is within the specified range.

To prevent electrical shock, disconnect instrument from mains (line) before cleaning. Use a dry cloth or one slightly dampened with water to clean the external case parts. Do not attempt to clean internally.

Ventilation Requirements: When installing the product in a cabinet, the convection into and out of the product must not be restricted. The ambient temperature (outside the cabinet) must be less than the maximum operating temperature of the product by 4° C for every 100 watts dissipated in the cabinet. If the total power dissipated in the cabinet is greater than 800 watts, then forced convection must be used.

Product Markings

CE - the CE mark is a registered trademark of the European Community. A CE mark accompanied by a year indicated the year the design was proven.

CSA - the CSA mark is a registered trademark of the Canadian Standards Association.

CERTIFICATION

Hewlett-Packard Company certifies that this product met its published specifications at the time of shipment from the factory. Hewlett-Packard further certifies that its calibration measurements are traceable to the United States National Bureau of Standards, to the extent allowed by the Bureau's calibration facility, and to the calibration facilities of other International Standards Organization members.

WARRANTY

This Hewlett-Packard instrument product is warranted against defects in material and workmanship for a period of one year from date of shipment. During the warranty period, Hewlett-Packard Company will at its option, either repair or replace products which prove to be defective.

For warranty service or repair, this product must be returned to a service facility designated by HP. Buyer shall prepay shipping charges to HP and HP shall pay shipping charges to return the product to the Buyer. However, Buyer shall pay all shipping charges, duties, and taxes for products returned to HP from another country.

HP warrants that its software and firmware designated by HP for use with an instrument will execute its programming instructions when properly installed on that instrument. HP does not warrant that the operation of the instrument, or software, or firmware will be uninterrupted or error free.

LIMITATION OF WARRANTY

The foregoing warranty shall not apply to defects resulting from improper or inadequate maintenance by Buyer, Buyer-supplied software or interfacing, unauthorized modification or misuse, operation outside of the environmental specifications for the product, or improper site preparation or maintenance.

NO OTHER WARRANTY IS EXPRESSED OR IMPLIED. HP SPECIFICALLY DISCLAIMS THE IMPLIED WARRANTIES OF MERCHANTABILITY AND FITNESS FOR A PARTICULAR PURPOSE.

EXCLUSIVE REMEDIES

THE REMEDIES PROVIDED HEREIN ARE BUYER'S SOLE AND EXCLUSIVE REMEDIES. HP SHALL NOT BE LIABLE FOR ANY DIRECT, INDIRECT, SPECIAL, INCIDENTAL, OR CONSEQUENTIAL DAMAGES, WHETHER BASED ON CONTRACT, TORT, OR ANY OTHER LEGAL THEORY.

ASSISTANCE

Product maintenance agreements and other customer assistance agreements are available for Hewlett-Packard products.

For any assistance, contact your nearest Hewlett-Packard Sales and Service Office. Addresses are provided at the back of this manual.

SAFETY CONSIDERATIONS

GENERAL

This product and related documentation must be reviewed for familiarization with safety markings and instructions before operation.

This product is a Safety Class I instrument (provided with a protective earth terminal).

BEFORE APPLYING POWER

Verify that the product is set to match the available line voltage and the correct fuse is installed.

SAFETY EARTH GROUND

An uninterruptible safety earth ground must be provided from the main power source to the product input wiring terminals, power cord, or supplied power cord set.

SAFETY SYMBOLS



Instruction manual symbol: the product will be marked with this symbol when it is necessary for the user to refer to the instruction manual (refer to Table of Contents).



Indicates hazardous voltages.



Indicates earth (ground) terminal.

WARNING

The WARNING sign denotes a hazard. It calls attention to a procedure, practice, or the like, which, if not correctly performed or adhered to, could result in personal injury. Do not proceed beyond a WARNING sign until the indicated conditions are fully understood and met.

CAUTION

The CAUTION sign denotes a hazard. It calls attention to an operating procedure, practice, or the like, which, if not correctly performed or adhered to, could result in damage to or destruction of part or all of the product. Do not proceed beyond a CAUTION sign until the indicated conditions are fully understood and met.

WARNING

Any interruption of the protective (grounding) conductor (inside or outside the instrument) or disconnecting the protective earth terminal will cause a potential shock hazard that could result in personal injury. (Grounding one conductor of a two conductor outlet is not sufficient protection).

Whenever it is likely that the protection has been impaired, the instrument must be made inoperative and be secured against any unintended operation.

If this instrument is to be energized via an autotransformer (for voltage reduction) make sure the common terminal is connected to the earth terminal of the power source.

Servicing instructions are for use by service-trained personnel only. To avoid dangerous electric shock, do not perform any servicing unless qualified to do so.

Adjustments described in the manual are performed with power supplied to the instrument while protective covers are removed. Energy available at many points may, if contacted, result in personal injury.

Capacitors inside the instrument may still be charged even if the instrument has been disconnected from its source of supply.

For continued protection against fire hazard, replace the line fuse(s) only with 250V fuse(s) of the same current rating and type (for example, normal blow, time delay, etc.). Do not use repaired fuses or short circuited fuseholders.

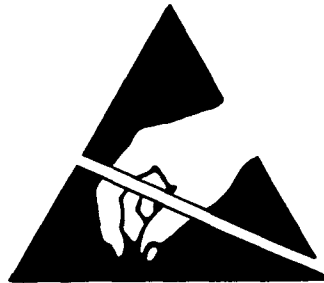

**ATTENTION
Static Sensitive
Devices**

This instrument was constructed in an ESD (electro-static discharge) protected environment. This is because most of the semiconductor devices used in this instrument are susceptible to damage by static discharge.

Depending on the magnitude of the charge, device substrates can be punctured or destroyed by contact or mere proximity of a static charge. The results can cause degradation of device performance, early failure, or immediate destruction.

These charges are generated in numerous ways such as simple contact, separation of materials, and normal motions of persons working with static sensitive devices.

When handling or servicing equipment containing static sensitive devices, adequate precautions must be taken to prevent device damage or destruction.

Only those who are thoroughly familiar with industry accepted techniques for handling static sensitive devices should attempt to service circuitry with these devices.

In all instances, measures must be taken to prevent static charge build-up on work surfaces and persons handling the devices.

For further information on ESD precautions, refer to "SPECIAL HANDLING CONSIDERATIONS FOR STATIC SENSITIVE DEVICES" in Section VIII Service Section.

TABLE OF CONTENTS

Section 1—General Information

Introduction	1-1
Specifications	1-1
Safety Considerations	1-2
Instruments Covered By Manual	1-2
Manual Changes	1-2
Description	1-3
General	1-3
Audio Testing	1-3
Transceiver Testing	1-4
Systems	1-5
Options	1-6
Electrical Options	1-6
Mechanical Options	1-6
Hewlett-Packard Interface Bus	1-8
Compatibility	1-8
Selecting the HP-IB Address	1-8
Accessories Supplied	1-8
Electrical Equipment Available	1-8
HP-IB Controllers	1-8
Front-to-Rear-Panel Connectors Retrofit Kit	1-8
Rear-to-Front-Panel Connectors Retrofit Kit	1-8
Mechanical Equipment Available	1-9
Chassis Slide Mount Kit	1-9
Chassis Tilt Slide Mount Kit	1-9
Recommended Test Equipment	1-9
Principles of Operation for Simplified Block Diagram	1-9
Voltmeter and Notch Filter	1-10
Counter	1-11
Source	1-11
Controller	1-12
Basics of Audio Measurements	1-12
AC Level	1-12
Frequency	1-13
DC Level	1-13
Signal Impurities	1-13
Distortion	1-13
SINAD	1-15
Signal-to-Noise Ratio	1-15
Internal Source	1-16
Plotting	1-16

Section 2–Installation

- Introduction 2-1
- Initial Inspection 2-1
- Preparation for Use 2-1
 - Power Requirements 2-1
 - Line Voltage and Fuse Selection 2-2
 - Power Cables 2-2
 - HP-IB Address Selection 2-3
 - Interconnections 2-5
 - Mating Connectors 2-5
- Operating Environment 2-6
 - Bench Operation 2-6
 - Rack Mounting 2-6
- Storage and Shipment 2-8
 - Environment 2-8
 - Packaging 2-8

Section 3–Operation

- Introduction 3-1
 - General 3-1
 - Operating Characteristics 3-1
 - Turn-On Procedure 3-1
 - Local Operation 3-2
 - Remote Operation 3-3
- Operator’s Checks 3-3
 - Operator’s Maintenance 3-4
- Front-Panel Features 3-6
- Basic Functional Checks 3-12
- Simplified Operation 3-8
- Rear-Panel Features 3-11
 - Description 3-12
 - Equipment 3-12
 - Procedure 3-12
 - Preliminary Check 3-12
 - AC Level and Output Level Check 3-12
 - Filter Check 3-13
 - Distortion Check 3-15
 - SINAD Check 3-15
 - Signal-to-Noise Ratio Check 3-15
 - Sweep, X Axis, Y Axis, Pen Lift, and DC Level Check 3-15
- HP-IB Functional Checks 3-16
 - Description 3-16
 - Initial Setup 3-16
 - Equipment 3-16
 - Address Recognition 3-16
 - Remote and Local Messages and the LCL Key 3-17
 - Sending the Data Message 3-17
 - Receiving the Data Message 3-18
 - Local Lockout and Clear Lockout/Set Local Messages 3-18

Clear Message	3-18
Abort Message	3-19
Status Byte Message	3-20
Require Service Message	3-21
Trigger Message and Clear Key Triggering	3-22
Remote Operation, Hewlett-Packard Interface Bus	3-22
HP-IB Compatibility	3-23
Remote Mode	3-23
Local Mode	3-23
Addressing	3-23
Data Messages	3-26
Receiving the Data Message	3-26
Sending the Data Message	3-30
Receiving the Clear Message	3-31
Receiving the Trigger Message	3-32
Receiving the Remote Message	3-32
Receiving the Local Message	3-33
Receiving the Local Lockout Message	3-33
Receiving the Clear Lockout/Set Local Message	3-33
Receiving the Pass Control Message	3-33
Sending the Require Service Message	3-33
Selecting the Service Request Condition	3-34
Sending the Status Byte Message	3-34
Sending the Status Bit Message	3-35
Receiving the Abort Message	3-35
HP-IB Syntax and Characteristics Summary	3-35
AC Level	3-42
Amplitude	3-44
Automatic Operation	3-46
Common Mode	3-47
DC Level	3-50
Default Conditions and Power-up Sequence	3-52
Detector Selection	3-53
Display Level in Watts	3-55
Display Source Settings	3-57
Distortion	3-58
Distortion Level	3-60
Error Disable	3-62
Error Message Summary	3-64
Filters	3-68
Float	3-72
Frequency	3-74
Hold Decimal Point	3-76
Hold Settings	3-78
HP-IB Address	3-79
Increment	3-82
Input Level Range (DC Level)	3-84
Input Level Range (Except DC Level)	3-86
Monitor	3-88
Notch Tune	3-91
Output Impedance	3-93
Plot Limit	3-96
Post-Notch Detector Filtering (Except SINAD)	3-98

Post-Notch Gain	3-100
Rapid Frequency Count	3-102
Rapid Source	3-105
RATIO and LOG/LIN	3-109
Read Display to HP-IB	3-112
Service Request Condition	3-114
Signal-to-Noise	3-116
Special Functions	3-121
Sweep	3-128
Sweep Resolution	3-131
Time Between Measurements	3-134
X-Y Recording	3-135

Section 4—Performance

Introduction	4-1
Equipment Required	4-1
Test Record	4-1
Calibration Cycle	4-1
Abbreviated Performance Testing	4-1
Performance Test 1 AC Level Accuracy and Output Level Accuracy and Flatness	4-2
Performance Test 2 DC Level Accuracy	4-12
Performance Test 3 Distortion and Noise	4-14
Performance Test 4 Distortion, SINAD, and Signal-to-Noise Accuracy	4-16
Performance Test 5 Frequency Accuracy and Sensitivity	4-19
Performance Test 6 Audio Filters	4-21
Performance Test 7 Input and Output Impedance	4-28
Performance Test 8 Common-Mode Rejection Ratio	4-29

Section 5—Adjustments

Introduction	5-1
Safety Considerations	5-1
Equipment Required	5-1
Factory-Selected Components	5-1
Post-Repair Tests, Adjustments, and Checks	5-2
Related Adjustments	5-2
Adjustment 1 Internal Reference Frequency	5-4
Adjustment 2 Input Flatness	5-5
Adjustment 3 Common Mode Rejection	5-8
Adjustment 4 Input DC Offset	5-9
Adjustment 5 400 Hz High-Pass and Weighting Bandpass Filters	5-10
Adjustment 6 Notch Filter Tune and Balance	5-12
Adjustment 7 Voltmeter	5-13
Adjustment 8 SINAD Meter	5-15
Adjustment 9 Oscillator and Output Attenuator	5-16

Section 1

GENERAL INFORMATION

1-1. INTRODUCTION

This manual contains information required to install, operate, test, adjust, and service the Hewlett-Packard Model 8903B Audio Analyzer. This manual documents options installed in the Audio Analyzer such as rear-panel connections and internal plug-in filters.

This section of the manual describes the instruments documented by the manual and covers instrument description, options, accessories, specifications, and other basic information. This section also contains principles of operation on a simplified block diagram level and basic information on audio measurements. The other sections contain the following information:

Section 2, Installation: provides information about initial inspection, preparation for use (including address selection for remote operation), and storage and shipment.

Section 3, Operation: provides information about panel features, and includes operating checks, operating instructions for both local and remote operation, and maintenance information.

Section 4, Performance Tests: provides the information required to check performance of the instrument against the critical specifications in Table 1-1.

Section 5, Adjustments: provides the information required to properly adjust the instrument.

Section 6, Replaceable Parts: provides ordering information for all replaceable parts and assemblies.

Section 7, Instrument Changes: provides instrument modification recommendations and procedures.

Section 8, Service: provides the information required to repair the instrument.

Sections 1 through 5 are bound in this volume, the Operation and Calibration Manual. One copy of the Operation and Calibration Manual is supplied with the instrument. Sections 6 through 8 are bound in two separate volumes, the Service Manual. Copies of the Service Manual are not supplied with the instrument unless specifically requested (as Option 915) at time of instrument order. Copies of all volumes can be ordered separately through your nearest Hewlett-Packard office. The part numbers are listed on the title page of this manual.

Also listed on the title page of this manual, below the manual part number, is a microfiche part number. This number may be used to order 100 × 150 mm (4 × 6 inch) microfilm transparencies of this manual. Each microfiche contains up to 96 photo-duplicates of the manual's pages. The microfiche package also includes the latest MANUAL UPDATES packet, as well as all pertinent Service Notes.

1-2. SPECIFICATIONS

Instrument specifications are listed in Table 1-1. These are the performance standards, or limits against which the instrument may be tested. Characteristics listed under Supplemental Information, Table 1-2, are not warranted specifications but are typical characteristics included as additional information for the user.

1-3. SAFETY CONSIDERATIONS

This product is a Safety Class I instrument (that is, provided with a protective earth terminal). The Audio Analyzer and all related documentation must be reviewed for familiarization with safety markings and instructions before operation. Refer to the Safety Considerations page found at the beginning of this manual for a summary of the safety information. Safety information pertinent to the task at hand (installation, performance testing, adjustment, or service) is found throughout the manual.

1-4. INSTRUMENTS COVERED BY MANUAL

Serial Numbers. This instrument has a two-part serial number in the form 0000A00000 which is stamped on the serial number plate attached to the rear of the instrument. The first four digits and the letter constitute the serial number prefix, and the last five digits form the suffix. The prefix is the same for all identical instruments. It changes only when a change is made to the instrument. The suffix, however, is assigned sequentially and is different for each instrument. The contents of this manual apply directly to instruments having the same serial prefix(es) as listed under SERIAL NUMBERS on the title page.

Options. Electrical Option 001, internal plug-in filter options, and various mechanical options are documented in this manual. The differences are noted under the appropriate paragraph such as Options in Section 1, the Replaceable Parts List, and the schematic diagrams.

1-5. MANUAL UPDATES

An instrument manufactured after the printing of this manual may have a serial prefix that is not listed on the title page. Having a serial number prefix that is greater than that shown on the title page indicates that the instrument is slightly different from those documented in the manual. In this case, your manual is provided with updating information to make it as current as possible. This updating information includes any hardware or software changes that have occurred as well as corrections to the manual.

A Description of the Manual Update Packet

A "MANUAL UPDATES" packet is shipped with the Operation and Calibration Manual when necessary to provide you with the most current information available at the time of shipment. These packets consist of replacement and addition pages which should be incorporated into the manual to bring it up to date.

Signing Up for the Documentation Update Service

Hewlett-Packard offers a Documentation Update Service that will provide you with further updates and changes as they become available. If you have not received update information that matches the serial number of your instrument, you can receive this information through the Update Service.

If you operate or service instruments with different serial prefixes, we strongly recommend that you join this service immediately to ensure that your manual is kept current. For more information, refer to the Documentation Update Service reply card included in this manual or contact:

Hewlett-Packard Company
Technical Writing Department
24001 E. Mission-TAF C-34
Spokane, WA. 99220
(509) 922-4001

1-6. DESCRIPTION

General

The HP Model 8903B Audio Analyzer is a complete audio measurement system covering the frequency range of 20 Hz to 100 kHz. It combines a low-distortion signal source with a signal analyzer. The source has a maximum open-circuit output of 6 V_{rms} and a selectable output impedance of either 50 or 600Ω. The analyzer can perform distortion analysis, frequency count, and ac level, dc level, SINAD, and signal-to-noise ratio measurements. The Audio Analyzer reduces the number of instruments required in many applications involving audio signal characterization.

The Audio Analyzer is easy to use. All measurements are selected by one or two keystrokes. For distortion measurements, the Audio Analyzer automatically tunes to and levels the input signal. Measurement and output ranges are automatically selected for maximum resolution and accuracy. Furthermore, tuning is independent of the source. Thus, the source can be set to one frequency while the analyzer is measuring the distortion on a signal at another frequency (that is, there is no need to tune the analyzer to the source).

The combined capabilities of the instrument are enhanced by microprocessor control, resulting in more capability than would be available from separate instruments. For example, when making signal-to-noise ratio measurements, the Audio Analyzer monitors the ac level while turning the source on and off. The microprocessor then computes and displays the ratio of the on and off levels. The ratio can be displayed in either % or dB.

In addition, the source can be swept. This makes measurements such as frequency response or complete distortion characterization simple to perform. Microprocessor control allows flexible entry of source parameters and versatile display formats. For example, ac level can be displayed in V, mV, dBm into 600Ω, watts, or as a ratio (in % or dB) referenced to an entered or measured value.

Virtually all functions are remotely programmable through the Hewlett-Packard Interface Bus (HP-IB¹). Programming is easy and straightforward; all measurements are made through a single input. This eliminates the need to switch between multiple inputs under remote control and reduces software development time and hardware costs. The Audio Analyzer measures the true rms level on all ac measurements. True rms measurements assure greater accuracy when measuring complex waveforms and noise. For those applications where average detection is required, the analyzer can be switched to average-responding (rms calibrated) detection through special functions. Accurate distortion measurements typically can be made to less than 0.003% (-90 dB) between 20 Hz and 20 kHz at a 1.5V level. For those applications where quasi-peak detection is required, the analyzer (Serial Prefix 2730A and above) can be switched to this type of detection through special functions. This detector is designed to meet the requirements specified by CCIR 468-3.

Audio Testing

The Audio Analyzer has numerous features which make audio testing simple and convenient. These features include flexible data entry and display formats, convenient source control, and swept measurements capability. For example, distortion results can be displayed in % or dB. AC level measurements can be displayed in volts, dBm into 600Ω, or watts. Measurement results can be displayed in % or dB relative to a measured or entered value. Finding the 3 dB points of filters and amplifiers is simplified by using the source frequency increment and decrement keys together with the relative display feature. A major contribution of the Audio Analyzer is its ability to make swept measurements. When sweeping, the Audio Analyzer tuning steps its source frequency in logarithmic increments. With an x-y recorder, hard copy measurement results can be obtained. X-axis scaling is determined by the entered start and stop frequencies. Y-axis scaling is determined by the measurement units selected and the plot limits entered through the keyboard. Any valid display units (except mV) are allowed when plotting. To change the scaling from frequency response to swept distortion plots, simply key in new

¹ HP-IB: Not just IEEE-488, but the hardware, documentation and support that delivers the shortest path to a measurement system.

values for the plot limits. No adjustment of the x-y recorder is necessary. The Audio Analyzer also features high accuracy. The instrument can typically measure flatness to 0.5% (0.05 dB) over the range of 20 Hz to 20 kHz and swept distortion over the same range to 0.003% (-90 dB). See Figures 1-1 and 1-2.

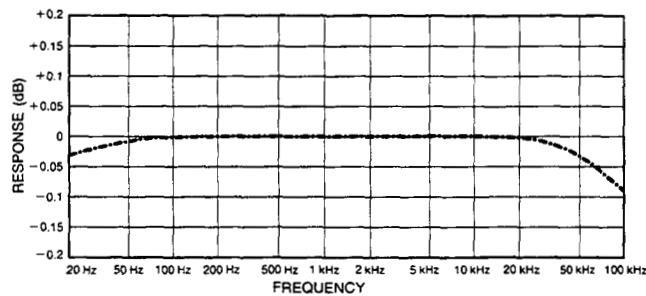

Figure 1-1. Typical Combined Source and AC Level Flatness

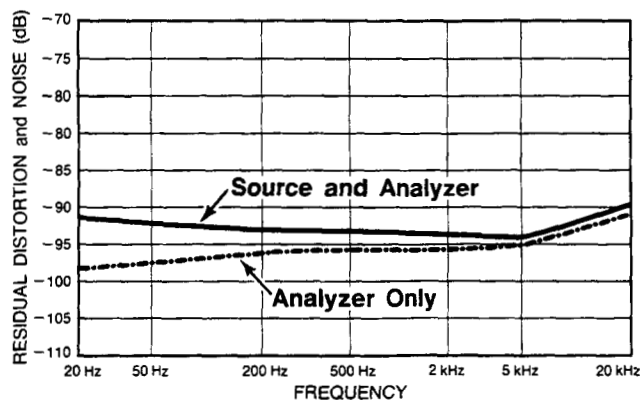

Figure 1-2. Typical Combined Source and Analyzer Residual Distortion With V_{source} Set to 1.5V (80 kHz BW)

Balanced Input. The Audio Analyzer has a selectable balanced input configuration for testing balanced devices. For example, in the quest for higher output power, many audio amplifiers use bridged output stages. Such amplifiers can be difficult to characterize because their outputs cannot be grounded. To test these devices, the usual approach has been to use a balanced, calibrated isolation transformer connected to an analyzer with an unbalanced input. Balanced inputs on the Audio Analyzer make transformers unnecessary. With the analyzer input in the float position, connect the bridged device directly to the Audio Analyzer to make measurements.

Transceiver Testing

The Audio Analyzer has several measurements and features specifically designed for transceiver testing. It has SINAD and signal-to-noise ratio measurements for receiver testing, optional internal plug-in weighting filters for testing to international standards, a reciprocal counter for measuring squelch tones, and an optional internal plug-in 400 Hz high-pass filter for eliminating squelch tones when measuring transmitter audio distortion.

SINAD is one of the most basic receiver measurements. It must be made repeatedly when performing sensitivity or adjacent-channel sensitivity tests. In the Audio Analyzer, the SINAD measurement is more heavily filtered than the distortion measurement in order to smooth the noisy signals encountered in receiver testing. The filtering is optimized for excellent repeatability and speed (2 readings/second typical). Some automatic distortion analyzers have a tendency to become untuned when measuring SINAD on noisy signals. The Audio Analyzer overcomes this problem by tuning the notch filter to

the source frequency when measuring SINAD. SINAD measurement results are indicated both by the digital display and a front-panel analog meter. The meter is specifically marked for EIA and CEPT sensitivity and selectivity. For SINAD ratios less than 25 dB, the digital display is automatically rounded to the nearest 0.5 dB to reduce digit flicker.

Signal-to-noise ratio measurements are also filtered for improved repeatability and speed (1 reading/second typical), and automatic display rounding is provided. For accurate noise measurements, the Audio Analyzer uses true rms detection for both SINAD and signal-to-noise measurements. Most older instruments employ average detection which reads low for noise. The discrepancy can be 1.5 dB or greater and varies with the ratio being measured. For correlating results with past test data, the Audio Analyzer's detector can be switched via special functions to an average responding configuration.

For those applications where quasi-peak detection is required, the analyzer (Serial Prefix 2730A and above) can be switched to this type of detection through special functions. This detector is designed to meet the requirements specified by CCIR 468-3.

For transceivers, the Audio Analyzer has an optional, internal plug-in seven-pole 400 Hz high-pass filter for rejecting squelch tones. Rejection of squelch tones up to 250 Hz is greater than 40 dB. Therefore, audio distortion measurements to 1% residual distortion can be made without disabling the transmitter squelch tones.

Under remote control, the Audio Analyzer can generate or count burst tone sequences. Typically the maximum count rate is 8 ms/reading and the minimum tone duration is 12 ms. This is fast enough for applications such as unquenching pagers (see Figure 1-3).

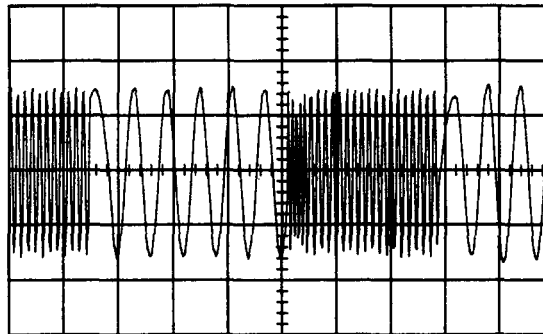

Figure 1-3. Two-Tone Burst Sequence (15 ms Duration)

Systems

The Audio Analyzer features capabilities for general systems applications. The audio source is programmable in frequency, level, and output impedance has very low distortion. The distortion measurements are fully automatic, programmable, and fast. The typical time to tune and return the first distortion measurement is 1.5 seconds with a measurement rate of 2 readings/second thereafter. The combined distortion of the internal source together with the measurement section is typically 0.003% (-90 dB) between 20 Hz and 20 kHz at a 1.5V level.

Often systems applications involve measuring low level ac signals. The Audio Analyzer features a full range ac level display of 0.3000 mV with an accuracy of 4% of reading (2% of reading for levels >50 mV and from 20 Hz to 20 kHz). The ac detector is switchable between true rms, average-responding, and Quasi-peak detection. The 3 dB measurement bandwidth for each detector is greater than 500 kHz.

Since many systems have noise problems, the Audio Analyzer has both 30 and 80 kHz low-pass filters to reject high frequency noise. In addition, the optional internal plug-in 400 Hz high-pass filter attenuates line-related hum and noise by more than 68 dB.

Two special binary programming modes are available in remote operation. A rapid frequency count mode provides a packed, four-byte output for fast counting. Also, a rapid source binary programming mode is available which allows the internal oscillator tuning to be programmed directly with five bytes of data.

1-7. OPTIONS

Electrical Options

Electrical Option 001. This option provides rear-panel (instead of front-panel) connections for both the INPUT and OUTPUT HIGH and LOW BNC connectors.

Internal Plug-in Filter Options. The Audio Analyzer has two plug-in filter positions; each position can be loaded with any one of six optional filters. Each filter is referenced to its corresponding filter position by one of two option numbers. For example, the 400 Hz high-pass filter option can be ordered as Option 010 which corresponds to the left-most filter position, or as Option 050 which corresponds to the right-most filter position. These optional plug-in filters can be configured in any combination desired. (If there is no filter ordered for a position, a jumper is loaded and a label marked "No Filter" is placed above the filter key on the front panel.) The following list includes the name and option numbers for each available filter.

- 400 Hz High-Pass Filter (Option 010, 050)
- CCITT Weighting Filter (Option 011, 051)
- CCIR Weighting Filter (Option 012, 052)
- C-MESSAGE Weighting Filter (Option 013, 053)
- CCIR/ARM Weighting Filter (Option 014, 054)
- "A" Weighting Filter (Option 015, 055)

Specific information on each plug-in filter option can be found in the Detailed Operating Instructions in Section 3 under "Filters".

Mechanical Options

The following options may have been ordered and received with the Audio Analyzer. If they were not ordered with the original shipment and are now desired, they can be ordered from the nearest Hewlett-Packard office using the part number included in each of the following paragraphs. The mechanical options are shown in Figure 1-4.

Front Handle Kit (Option 907). Ease of handling is increased with the front-panel handles. Order HP part number 5061-9689.

Rack Flange Kit (Option 908). The Audio Analyzer can be solidly mounted to an instrument rack using the flange kit. Order HP part number 5061-9677.

Rack Flange and Front Handle Combination Kit (Option 909). This is not a front handle kit and a rack flange kit packaged together; it is composed of a unique part which combines both functions. Order HP part number 5061-9683.

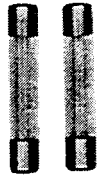

SPARE INTERNAL FUSES

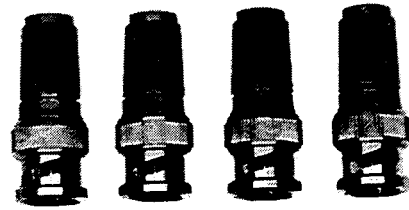

BNC TO BANANA PLUG ADAPTERS

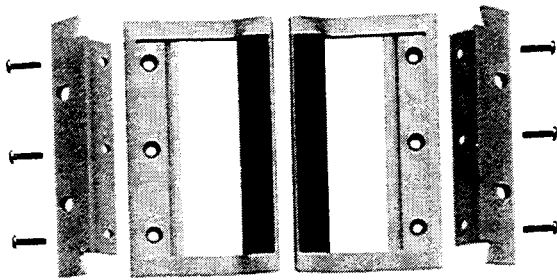

**OPTION 909
RACK FLANGE AND FRONT
HANDLE COMBINATION KIT**

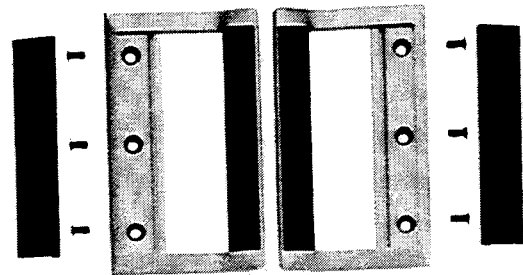

**OPTION 907
FRONT HANDLE KIT**

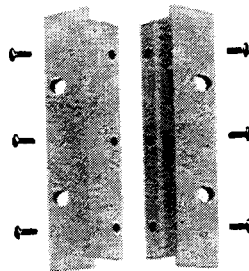

**OPTION 908
RACK FLANGE KIT**

NOTE: Refer to ACCESSORIES SUPPLIED, for more details.

Figure 1-4. HP 8903B Accessories Supplied, and Options 907, 908, and 909

1-8. HEWLETT-PACKARD INTERFACE BUS

Compatibility

The Audio Analyzer is compatible with HP-IB to the extent indicated by the following code: SH1, AH1, T5, TE0, L3, LE0, SR1, RL1, PP0, DC1, DT1, C0, E1. The Audio Analyzer interfaces with the bus via open collector TTL circuitry. An explanation of the compatibility code can be found in IEEE Standard 488, *IEEE Standard Digital Interface for Programmable Instrumentation* or the identical ANSI Standard MC1.1. For more detailed information relating to programmable control of the Audio Analyzer, refer to *Remote Operation, Hewlett-Packard Interface Bus* in Section 3 of this manual.

Selecting the HP-IB Address

The HP-IB address switches are located within the Audio Analyzer. The switches represent a five-bit binary number. This number represents the talk and listen address characters which an HP-IB controller is capable of generating. In addition, two more switches allow the Audio Analyzer to be set to talk only or listen only. A table in Section 2 shows all HP-IB talk and listen addresses. Refer to *HP-IB Address Selection* in Section 2 of this manual.

1-9. ACCESSORIES SUPPLIED

The accessories supplied with the Audio Analyzer are shown in Figure 1-4.

Fast blow fuses with a 1.5A rating for 100/120 Vac operation (HP 2110-0043) and a 1.0A rating for 220/240 Vac operation (HP 2110-0001) are supplied. One fuse is installed in the instrument at the time of shipment. The rating of the installed fuse is selected according to the line voltage specified by the customer. If the voltage is not specified, the rating of the installed fuse will be selected according to the country of destination.

Four type BNC-to-banana-plug adapters (HP 1250-2164) are also supplied for use when double-ended inputs or outputs are desired. The conductor of the banana connector is connected to the center conductor of the BNC connector adapted to. These adapters are used when the front-panel INPUT or OUTPUT FLOAT switches are set to FLOAT.

1-10. ELECTRICAL EQUIPMENT AVAILABLE

(Also refer to Service Accessories, Table 1-4.)

HP-IB Controllers

The Audio Analyzer has an HP-IB interface and can be used with any HP-IB compatible computing controller or computer for automatic systems applications.

Front-to-Rear-Panel Connectors Retrofit Kit

This kit contains all the necessary components and full instructions for converting instruments with front-panel connections for INPUT and OUTPUT HIGH and LOW to rear-panel connections. For serial prefixes 2730A and below, order HP part number 08903-60171. For serial prefix 2742A and above, order HP part number 08903-60199. After installation and calibration, performance will be identical to the HP 8903B Option 001.

Rear-to-Front-Panel Connectors Retrofit Kit

This kit contains all the necessary components and full instructions for converting instruments with rear-panel connections for INPUT and OUTPUT HIGH and LOW to front-panel connections. For serial prefix 2730A and below order HP part number 08903-60172. For serial prefix 2742A and above, order HP part number 08903-60200. After installation and calibration, performance will be identical to the standard HP 8903B.

1-11. MECHANICAL EQUIPMENT AVAILABLE

Chassis Slide Mount Kit

This kit is extremely useful when the Audio Analyzer is rack mounted. Access to internal circuits and components or the rear-panel is possible without removing the instrument from the rack. Order HP part number 1494-0060 for 431.8 mm (17 in.) fixed slides and part number 1494-0061 for the correct adapters for non-HP rack enclosures.

Chassis Tilt Slide Mount Kit

This kit is the same as the Chassis Slide Mount Kit above except it also allows the tilting of the instrument up or down 90°. Order HP part number 1494-0062 for 431.8 mm (17 in.) tilting slides and part number 1494-0061 for the correct adapters for non-HP rack enclosures.

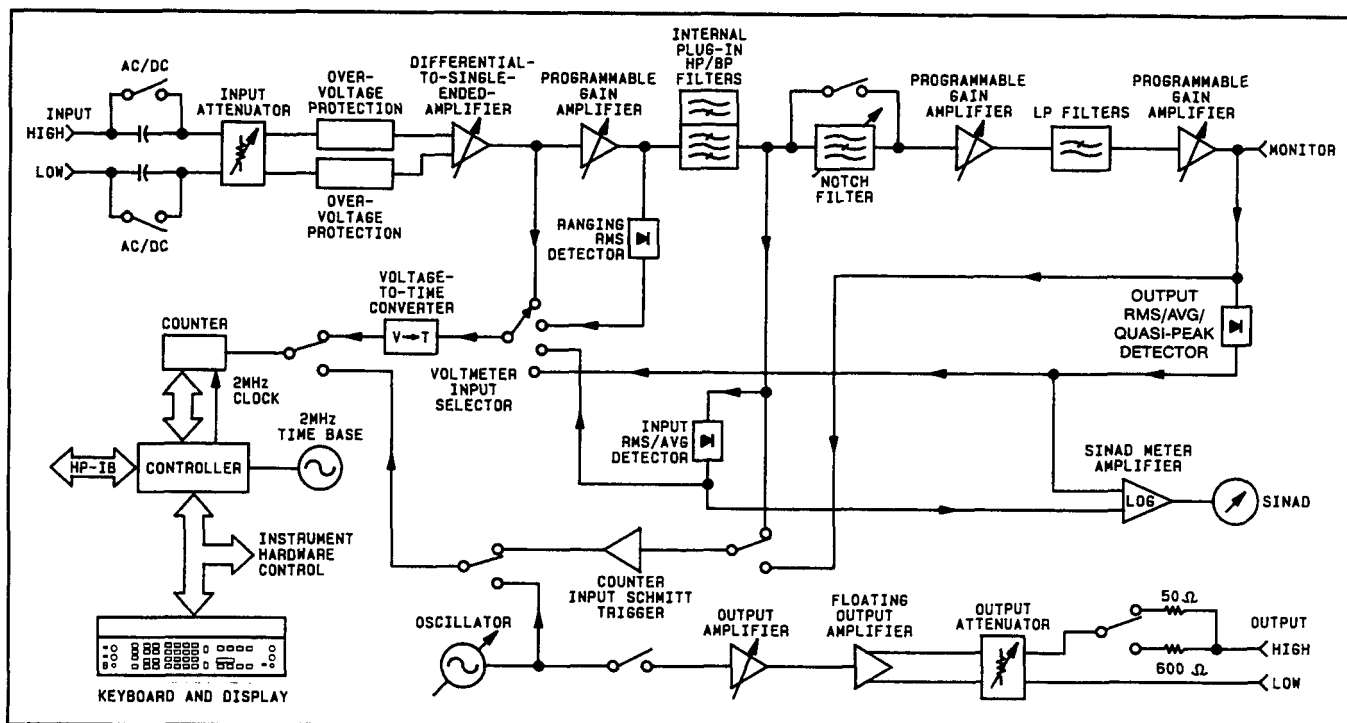

Figure 1-5. Simplified HP 8903B Audio Analyzer Block Diagram

1-12. RECOMMENDED TEST EQUIPMENT

Table 1-3 lists the test equipment recommended for use in testing, adjusting, and servicing the Audio Analyzer. If any of the recommended equipment is unavailable, instruments with equivalent minimum specifications may be substituted. Table 1-3 also includes some alternate equipment listings.

1-13. PRINCIPLES OF OPERATION FOR SIMPLIFIED BLOCK DIAGRAM

The HP 8903B Audio Analyzer combines three instruments into one: a low-distortion audio source, a general purpose voltmeter with a tunable notch filter at the input, and a frequency counter. Measurements are managed by a microprocessor-based Controller. This combination forms an instrument that can make most common measurements on audio circuits automatically. To add to its versatility, the Audio Analyzer also has selectable input filters, logarithmic frequency sweep, x and y outputs for plotting measurement results vs. frequency, and HP-IB programmability.

The operation of the instrument is described in the following order: Voltmeter and Notch Filter, Counter, Source, and Controller. Refer to Figure 1-5.

Voltmeter and Notch Filter

The amplitude measurement path flows from the INPUT connectors (HIGH and LOW) to the MONITOR output (on the rear panel) and includes the Input RMS/Average and Output RMS/Average/Quasi-Peak Detectors, dc voltmeter (the Voltage-to-Time Converter and Counter), and SINAD meter circuitry. Measurements are made on the difference between the signals at the HIGH INPUT connector and the LOW INPUT connector (or ground). Differential and common-mode levels can be as high as 300V. Signals that are common to both the HIGH and LOW connectors are balanced out.

The input signal is ac coupled for all measurement modes except dc level. The signal is scaled by the Input Attenuator to a level of 3V or less. To protect the active circuits that follow, the Over-Voltage Protection circuit opens whenever its input exceeds 15V. The differential signal is converted to a single-ended signal (that is, a signal referenced to ground) and amplified. In the dc level mode, the dc voltage is measured at this point by the dc voltmeter. The signal is further amplified by a Programmable Gain Amplifier which is ac coupled. The gain of this amplifier and the Differential-to-Single-Ended Amplifier are programmed to keep the signal level into the Input Detector and Notch Filter between 1.7 and 3 V_{rms} to optimize their effectiveness and accuracy, particularly in the distortion and SINAD modes.

The output from the first Programmable Gain Amplifier is converted to dc by the Ranging RMS Detector and measured by the dc voltmeter. The output of this detector is used to set the gain of the input circuits. The signal then passes through the HP/BP filters to the Input RMS/Average Detector and becomes the numerator of the SINAD measurement and the denominator of the distortion measurement (refer to *Basics of Audio Measurements*). The Input RMS/Average Detector is not used to make the ac level measurement; the Output RMS/Average/Quasi-peak Detector is used for this measurement. For dc level measurements, the Ranging RMS Detector also monitors the ac component (if there is one) and lowers the gain of the input path if the signal will overload the input amplifiers; otherwise, the gain of the input path is determined by measuring the dc level. At this point, one of the two internal plug-in filters can be inserted into the signal path. The 400 Hz high-pass filter is usually used to suppress line hum or the low frequency squelch tone used on some mobile transceivers. The weighting filters have bandpass frequency responses that simulate the "average" response of human hearing. In the SINAD, distortion, and distortion level modes, the frequency of the input signal is counted at the output of the internal plug-in HP/BP Filters.

When measuring SINAD, distortion, or distortion level, the fundamental of the signal is removed by the Notch Filter. The output from the filter is the distortion and noise of the signal. In the ac level and signal-to-noise ratio modes the Notch Filter is bypassed. After amplifying and low-pass filtering, the output from the Notch Filter is converted to dc by the Output RMS/Average/Quasi-peak Detector and measured by the dc voltmeter.

When measuring distortion or distortion level, the Notch Filter is automatically tuned to the frequency counted at the input to the filter. Coarse tuning is via the Controller. Fine tuning and balance are via circuitry internal to the Notch Filter. When measuring SINAD, the Notch Filter is coarse tuned by the Controller to the same frequency as the internal source. Thus, a SINAD measurement is normally only made with the internal source as the stimulus and permits measurements in the presence of large amounts of noise (where the Controller would be unable to determine the input frequency). If an external source is used in the SINAD measurement mode, the source frequency must be within 5% of the frequency of the internal source. The two Programmable Gain Amplifiers, following the Notch Filter, amplify the low-level noise and distortion signals from the Notch Filter. The overall gain of the two amplifiers is normally set to maintain a signal level of 0.3 to 3V at the MONITOR output.

The 30 kHz and 80 kHz LP Filters are selected from the Keyboard. With no low-pass filtering, the 3 dB bandwidth of the measurement system is approximately 750 kHz. The filters are most often used to remove the high-frequency noise components in low-frequency SINAD and distortion measurements. The output from the second Programmable Gain Amplifier drives the rear-panel MONITOR output connector. The frequency of this signal is also measured by the Counter in the ac level and signal-to-noise ratio measurement modes because of the increased sensitivity at this point.

The Output Detector is read by the dc voltmeter in the ac level, SINAD (the denominator), distortion (the numerator), distortion level, and signal-to-noise ratio measurement modes. It is also used to set the

gain of the two Programmable Gain Amplifiers. Both the input and output detectors can be configured via special functions to respond to the absolute average of the signal instead of the true rms value. In the SINAD mode the outputs from the Input RMS/Average and Output RMS/Average/Quasi-peak Detectors are converted to a current representing the log of the ratio of the two signals by the SINAD Meter Amplifier to drive the SINAD panel meter. Since SINAD measurements are often made under very noisy conditions, the panel meter makes it easier to average the reading and to discern trends. The Voltage-to-Time Converter converts the dc inputs into a time interval which is measured by the Counter. The Output Detector can also be configured via special functions to respond to the quasi-peak of the signal. This type of detector is designed to respond to impulse type signals better than other types. The Quasi-peak Detector has a fast rise time coupled with a slow decay time constant which "captures" impulses or other signals with a high crest factor (noise or repetitive signal bursts).

Counter

The Counter is a reciprocal counter. To measure frequency, it counts the period of one or more cycles of the signal at its input, then the Controller divides the number of periods by the accumulated count. The reference for the Counter is the 2 MHz Time Base which also is the clock for the Controller. The Counter has four inputs and three modes of operation:

Voltage Measurement. The time interval from the Voltage-to-Time Converter is counted. The accumulated count is proportional to the dc voltage. For direct measurements (ac level, dc level, and distortion level), the count is processed directly by the Controller and displayed on the right display. For ratio measurements (SINAD, distortion, and signal-to-noise), the counts of two successive measurements are processed and displayed. For SINAD and distortion, the ratio of the output of the Input RMS/Average Detector and Output RMS/Average/Quasi-Peak Detector is computed. For signal-to-noise, the ratio of two consecutive outputs from the Output RMS/Average/Quasi-peak Detector is computed. One output is with the Oscillator on, the other is with the Oscillator off.

Input Frequency Measurement. The signal from the last Programmable Gain Amplifier or the HP/BP Filters is conditioned by the Counter Input Schmitt Trigger to make it compatible with the Counter's input. The period of the signal is then counted, the count is processed by the Controller, and the frequency is displayed on the left display.

Source Frequency Measurement. The Counter measures the frequency of the internal source only when the Oscillator is being tuned. The frequency is normally not displayed. To make a measurement of the source frequency, the output of the Oscillator is fed into the Counter, the period measured, and the result processed by the Controller.

Source

The source covers the frequency range from 20 Hz to 100 kHz. It is tuned to the frequency entered from Keyboard by the Controller using a tune-and-count routine. (Note that the frequency is not obtained by frequency synthesis.) The switch following the Oscillator is normally closed except in the signal-to-noise ratio measurement mode or when an amplitude of 0V is entered from the Keyboard. The output from the Oscillator is approximately 3V.

The Output Amplifier sets the source output level in fine steps. The Floating Output Amplifier converts the single-ended input into a floating signal (either output can be grounded or floated up to 10V peak). The Output Attenuator sets the output level in coarse steps. The maximum signal to the OUTPUT connectors is 6V into an open circuit or 3V into the matching termination. The output impedance of the source is HP-IB programmable to either 50 or 600 Ω . (The keyboard-selected level is the open-circuit level.)

Controller

The entire operation of the instrument is under control of a microprocessor-based Controller. The Controller sets up the instrument at turn-on, interprets Keyboard entries, executes changes in mode of operation, continually monitors instrument operation, sends measurement results and errors to the front-panel displays, and interfaces with HP-IB. In addition, its computing capability is used to simplify circuit operation. For example, it forms the last stage of the Counter, converts measurement results into ratios (in % or dB), etc. It also contains routines useful for servicing the instrument.

1-14. BASICS OF AUDIO MEASUREMENTS

The "audio" frequency range is usually taken to be from 20 Hz to 20 kHz. Few people have hearing that good, but the term is a convenient one to describe sub-RF frequencies encountered in electronics. The frequency range of the Audio Analyzer extends beyond the audio range to include fundamentals up to 100 kHz.

Electronic instrumentation provides most of the tools for quantitative analysis of audio signals. Thus, if the signal is non-electrical (for example, mechanical or acoustic), it must be converted to an electrical signal by a transducer of some kind (for example, strain gauge or microphone) before it can be analyzed. Apart from attentive listening to a hi-fi system, the most intuitive way of analyzing an electrical signal in the audio range is visually with an oscilloscope. Here you get a feeling for the signal's size (loudness), frequency (pitch), and shape (timbre). You can also determine if these parameters change with time or are stable, and you can even make some quantitative measurements on it (for example, peak level, dc offset, period, risetime, etc.). Many times, however, the parameter sought does not lend itself to easy visual analysis. Thus, the Audio Analyzer was designed. It combines into one instrument a series of general and specialized instruments, under microprocessor control, that make it easy for you to obtain accurate, quantitative measurements on audio signals of any general waveshape.

AC Level

Consider the very common measurement of a signal's ac rms level. To make this measurement with an oscilloscope, you must first decide the nature of the signal, because from it, the relationship of the peak level to the rms level can be mathematically determined. If the signal is sinusoidal, for example, the rms value is the peak amplitude divided by $\sqrt{2}$.

This measurement is greatly simplified with a rms voltmeter which electronically measures the rms level and displays the result. However, no other information about the signal is provided. The Audio Analyzer contains both an rms- and an average-responding voltmeter. The rms level of the signal is displayed whenever the AC LEVEL mode is selected. The average level can be displayed by entering 5.2 SPCL. The quasi-peak level can be displayed by entering 5.7 SPCL. A special function is also provided which converts the measurement result into watts for a specified (external) load resistance.

Another important ac signal characteristic is the variation in level vs. frequency (flatness). Of course you can easily set a reference level (such as 1V) at a particular frequency (such as 1 kHz) and monitor the change in level as the input frequency is changed. (The source's level is assumed to be flat; otherwise, it too must be checked.) The Audio Analyzer makes this measurement easier in three ways. First, the analyzer contains a flat, wide-range oscillator that can be used as the stimulus. Second, the reference can be set to 100% or 0 dB by the press of a button (the RATIO key). Third, the measurement can be automatically swept and the results can be plotted by connecting an x-y recorder to the (rear-panel) X AXIS and Y AXIS outputs.

An additional parameter related to ac level is gain, and more often, gain vs. frequency. To make a gain measurement, measure the input to the device, then the output, and take the ratio. This measurement is made easier by the Audio Analyzer when used with its internal oscillator. You first key in the desired input level, then either measure it and set it as a reference (press RATIO) or key in the level as the ratio reference. Then measure the output. The result can be expressed in either % or dB. If desired, the input can be swept and the gain plotted as a function of frequency (since the frequency plots logarithmically, the result is a Bode magnitude plot if dB is used).

Frequency

Another common and basic measurement is frequency. With an oscilloscope, you simply determine the time interval between like points on the repetitive waveform and take the reciprocal. With a frequency counter, frequency is measured electronically and displayed. The measurement is easier and usually much more accurate than could be made visually with an oscilloscope.

The Audio Analyzer contains a counter which displays the frequency of the input signal for all ac measurements. It should be noted that the counter is a reciprocal type; it measures the period of the signal (as you do with an oscilloscope) and computes the reciprocal to obtain the frequency. The advantage of this technique is that for low (audio) frequencies, higher resolution is obtained in a shorter measurement time.

DC Level

Although not part of an audio signal, dc level is a quantity often encountered in audio equipment (for example, bias voltages and outputs from ac-to-dc converters). Sometimes plots of dc level vs. frequency are desired (as in the case of an ac-to-dc converter).

The Audio Analyzer has dc level as one of its measurement modes.

Signal Impurities

Distortion, SINAD, and signal-to-noise ratio are used to describe the impurity content of a signal. These terms are somewhat related and can often be confused. A pure signal is defined as a perfect sinusoid, that is, one whose frequency spectrum contains only a single spectral component. Impurities are not always undesirable. Impurities, for example, are what add character to the sound of musical instruments. Pure signals in music sound monotonous. However, when testing a linear audio system, if a pure signal is applied to the input, anything but a pure signal at the output indicates that the system is degrading the signal. There are several common classifications of impurities: harmonic distortion (harmonics of the fundamental), intermodulation distortion (beat signals of two or more non-related signals), noise (random signals), and spurious signals (for example, line hum and interference). All but intermodulation distortion are easily measured by the Audio Analyzer.

Distortion

Harmonic distortion on a spectrally pure signal is created by non-linearities in the circuit through which it passes. The non-linearities can arise in the transfer characteristics of the active devices or by running the active device into saturation or cutoff. Often, distortion can be reduced by reducing the signal level, filtering, or adding negative feedback.

According to Fourier mathematics, the non-linear terms in the circuit's transfer function give rise to harmonics of the signal. Total harmonic distortion (THD) is usually defined as the ratio of the rms sum of the harmonics to the rms level of the fundamental. The ratio is usually converted to % or dB.

An oscilloscope gives only a rough indication of the amount of distortion present on a signal. A general rule of thumb is that if the non-linearity causing the distortion is "gentle" (for example, not clipped), a trained eye can discern distortion as low as 5% on an oscilloscope display. Figure 1-6 shows several examples of waveforms with 5% THD and the components that combined to produce them. (5% distortion would be considered quite high in a quality hi-fi amplifier.)

An audio spectrum analyzer, which allows the user to see the magnitude of all harmonics, is perhaps the best instrument to measure harmonic distortion. The audio spectrum analyzer method, however, requires a fairly expensive instrument and some mathematical manipulation.

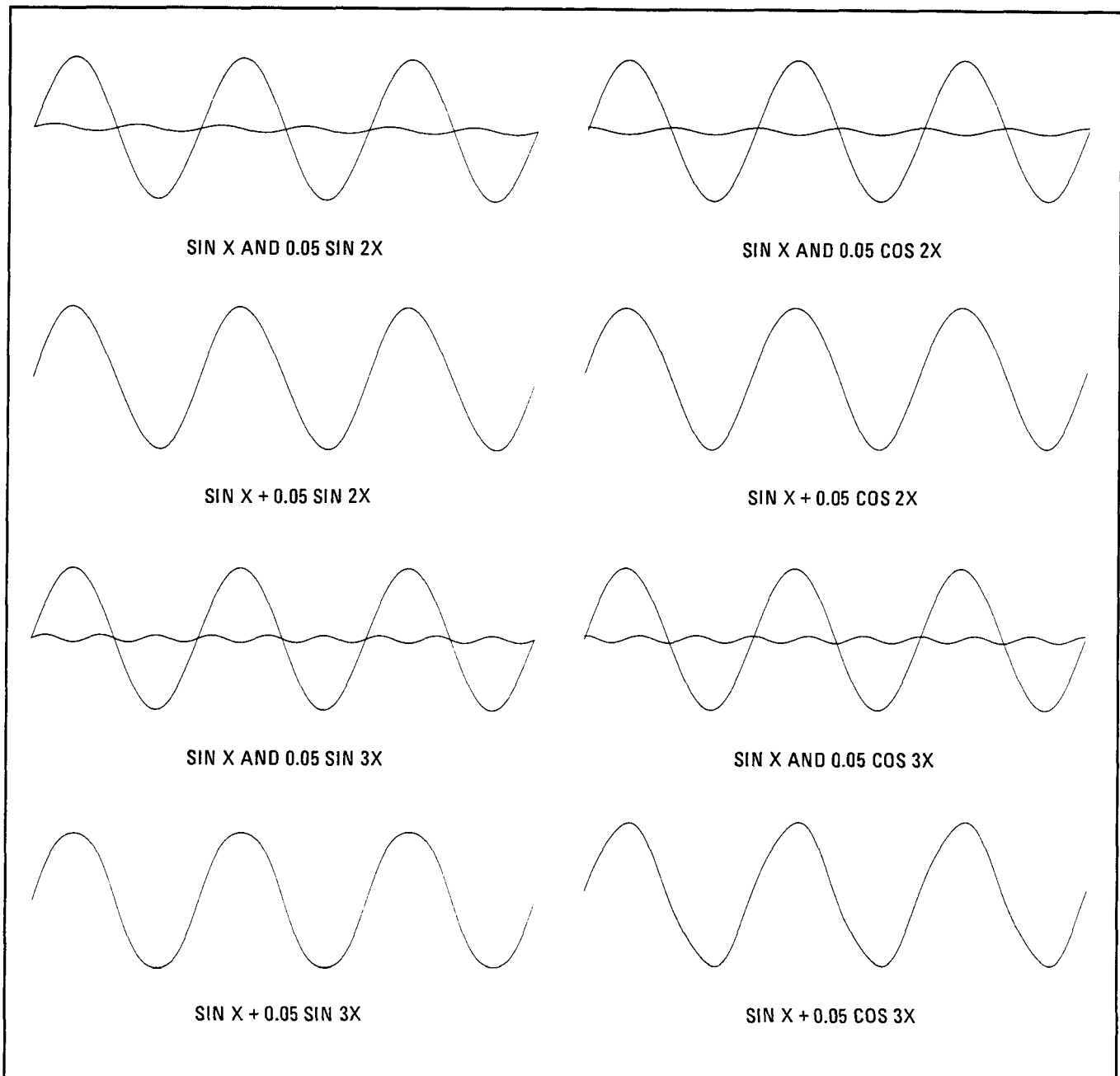

Figure 1-6. Several Waveforms Each With 5% THD and the Signal Components Which Produced Them

The traditional method of measuring distortion (accepted by the Institute of High Fidelity² and others) is with a distortion analyzer. The method is simple and adequate for most situations. With a distortion analyzer, you simply measure the signal level and set it up as a reference, then you insert a notch filter, tuned to the frequency of the fundamental, and measure the output of the filter relative to the input. This is the method used by the Audio Analyzer in the DISTN mode where the tuning and measuring are done automatically. When using the distortion analyzer method, it is important to understand that the measurement result is not "total harmonic distortion" as defined above except under the condition that the distortion is not too excessive but that it does predominate over any other signal impurities. Some examples will illustrate these restrictions.

² The Institute of High Fidelity, Inc., *Standard Methods Of Measurement For Audio Amplifiers*, The Institute of High Fidelity, Inc., New York (1978), p. 9.

Consider the case of excessive harmonic distortion. Let us use the example of a signal with 10% actual total harmonic distortion in which all the distortion comes from the second harmonic. The second harmonic is then 20 dB below the fundamental as viewed on a spectrum analyzer. When this signal is measured by a distortion analyzer, an error results from the first part of the measurement (measuring the input level) because the input level is not quite the same as the level of the fundamental. If the fundamental level were 1 Vrms, the second harmonic level would be 0.1 Vrms (one-tenth of the fundamental). The total input level (measured with a true rms voltmeter) is the rms sum of the two components, namely,

$$Input = \sqrt{(1)^2 + (0.1)^2} = 1.005V$$

or 0.5% high. Thus, the measurement result would be 9.95% distortion instead of the true 10%. Actually you can see that the distortion must really be excessive to affect the measurement significantly.

Now consider the case where other types of impurities are significant. Suppose the actual total harmonic distortion is 1% but that there is an additional hum component that has a level 1% of the fundamental level. The distortion measured by a distortion analyzer will be 1.4% (that is, 40% or 3 dB high). How, then, can you be sure that the result is a valid measurement of distortion? One way is to observe the (rear-panel) MONITOR output with an oscilloscope. If the waveform is clean and harmonically related to the fundamental, the measurement is actual total harmonic distortion. If it is not, selectable filters are provided to remove unwanted signals. Use the optional 400 Hz High-Pass Filter to remove line hum. Use the 30 kHz or 80 kHz Low Pass Filter to remove out-of-band noise. However, select only filters that do not affect the fundamental and the harmonics of interest. Sometimes it is desired to include hum and noise as part of the "distortion" measurement. For this reason, the measurement is often referred to as a THD + N (total harmonic distortion plus noise) measurement.

SINAD

For most practical purposes the SINAD measurement, as made by the Audio Analyzer, is equal to the reciprocal of the distortion measurement. It is usually expressed in dB. The one subtle distinction is that the notch filter is coarsely programmed to the frequency of the internal source (but fine tuned to the signal at its input). This permits measurements in the presence of large amounts of impurities and assures that the fundamental is tuned out. If an external source is used, it must be within 5% of the frequency setting of the internal source.

SINAD is an acronym for Signal, Noise, And Distortion. The ratio (normally expressed in dB) computed in the SINAD measurement is

$$SINAD = 20 \log \left(\frac{\text{rms value of signal, noise and distortion}}{\text{rms value of noise and distortion}} \right)$$

The equation eliminates the two restrictions discussed in connection with the distortion measurement.

SINAD is used most often in determining the sensitivity of a receiver. Receiver sensitivity is defined as the RF level that, when modulated in a specified manner with a pure audio tone, creates a certain SINAD (usually 10 or 12 dB) at the receiver's audio output. (The tone can just be discerned in the noise.) Sometimes a psophometric (that is, noise measuring) filter is required in the receiver sensitivity measurement. Optional plug-in weighting filters modify the frequency response of the Audio Analyzer with a bandpass characteristic that approximates the response of human hearing. Weighting filters which meet most international standards are available.

Signal-to-Noise Ratio

Measurement of the signal-to-noise ratio requires the use of the Audio Analyzer's internal source. The Audio Analyzer simply turns the source (set to a specified level) on and off and measures the ac level for both conditions. This is similar to the experience you have when listening to a recording at a comfortable volume, then lifting the tone arm and listening to the level of the residual hiss and hum.

Internal Source

The internal source is used when a low-distortion stimulus for the device under test is desired. Its distortion is about the same as that of the Audio Analyzer's measurement system. The combination permits measurements of distortion as low as 0.003% (-90 dB).

Plotting

When used in conjunction with the sweep mode, any of the measurements vs. frequency can be plotted using the rear-panel X and Y AXIS outputs and an x-y recorder. The internal source is used as the stimulus. This simplifies traditionally time consuming measurements such as flatness, gain, distortion, and SINAD vs. frequency, and does not require the use of an external controller (although this too can be used via HP-IB).

Table 1-1. Specifications (1 of 5)

All parameters describe performance in automatic operation or with properly set manual controls with a 1/2-hour warmup period.		
SYSTEM SPECIFICATIONS		
Characteristic	Performance Limits	Conditions
DISTORTION Residual Distortion and Noise (the higher of): 80 kHz BW 500 kHz BW SIG/NOISE Frequency Range Display Range Accuracy Input Voltage Range Residual Noise (the higher of)	-80 dB or 17 μ V -70 dB or 50 μ V -65 dB or 50 μ V 50 Hz to 100 kHz 0 to 99.99 dB ± 1 dB 50 mV to 300V -85 dB or 17 μ V -70 dB or 50 μ V	20 Hz to 20 kHz 20 Hz to 50 kHz 50 kHz to 100 kHz 80 kHz BW 500 kHz BW
SOURCE		
FREQUENCY Range Resolution Accuracy OUTPUT LEVEL Range Resolution Accuracy Flatness Distortion and Noise (the higher of) Impedance	20 Hz to 100 kHz 0.3% increments 0.3% of setting 0.6 mV to 6V Better than 0.3% $\pm 2\%$ of setting $\pm 3\%$ of setting $\pm 5\%$ of setting $\pm 0.7\%$ (± 0.06 dB) $\pm 2.5\%$ (± 0.22 dB) -80 dB or 15 μ V -70 dB or 38 μ V -65 dB or 38 μ V 600 Ω $\pm 1\%$ or 50 Ω $\pm 2\%$	Open circuit 60 mV to 6V; open circuit; 20 Hz to 50 kHz 6 mV to 6V; open circuit; 20 Hz to 100 kHz 0.6 mV to 6 mV; open circuit; 20 Hz to 100 kHz 20 Hz to 20 kHz; 1 kHz reference 20 Hz to 100 kHz; 1 kHz reference 20 Hz to 20 kHz; 80 kHz BW 20 Hz to 50 kHz; 500 kHz BW 50 kHz to 100 kHz; 500 kHz BW Front-panel selectable (HP-IB)
MEASUREMENT		
SINAD Fundamental Frequency Range Display Range Accuracy Input Voltage Range Residual Noise and Distortion (the higher of)	20 Hz to 100 kHz 0 to 99.99 dB ± 1 dB ± 2 dB 50 mV to 300V -80 dB or 15 μ V -70 dB or 45 μ V -65 dB or 45 μ V	20 Hz to 20 kHz (unfiltered or with low-pass filters) 20 kHz to 100 kHz 20 Hz to 20 kHz; 80 kHz BW 20 Hz to 50 kHz; 500 kHz BW 50 kHz to 100 kHz; 500 kHz BW

Table 1-1. Specifications (2 of 5)

SYSTEM SPECIFICATIONS (Cont'd)		
Characteristic	Performance Limits	Conditions
DISTORTION		
Fundamental		
Frequency Range	20 Hz to 100 kHz	
Display Range	0.001% to 100% (-99.99 to 0 dB)	
Accuracy	±1 dB ±2 dB	20 Hz to 20 kHz (unfiltered or with low-pass filters) 20 kHz to 100 kHz
Input Voltage Range	50 mV to 300V	
Residual Noise and Distortion (the higher of)	-80 dB or 15 µV -70 dB or 45 µV -65 dB or 45 µV	20 Hz to 20 kHz; 80 kHz BW 20 kHz to 50 kHz; 500 kHz BW 50 kHz to 100 kHz; 500 kHz BW
AC LEVEL		
Full Range Display	300.0V, 30.00V, 3.000V, .3000V, 30.00 mV, 3.000 mV, .3000 mV	
Overrange	33%	Except on the 300.0V range
Accuracy	±2% ±4% ±4%	50 mV to 300V; 20 Hz to 20 kHz 50 mV to 300V; 20 kHz to 100 kHz 0.3 mV to 50mV; 20 Hz to 100 kHz
DC LEVEL		
Full Range Display	300.0V, 48.00V, 16.00V, 4.00V	
Overrange	33%	Except on the 300.0V range
Accuracy	±1.0% of reading ±6 mV	600 mV to 300V Vin < 600 mV
FREQUENCY		
Measurement Range	20 Hz to 150 kHz 20 Hz to 100 kHz	In ac level mode In distortion, SINAD, and signal-to-noise modes
Resolution	5 digits 0.01 Hz	Frequencies >100 Hz Frequencies <100 Hz
Accuracy	±(0.004% +1 digit)	
Sensitivity	50 mV 5.0 mV	Distortion and SINAD modes only In ac level and signal-to-noise modes only
STANDARD AUDIO FILTERS		
30 kHz Low-pass Filter		
3 dB Cutoff		
Frequency	30 ±2 kHz	
Rolloff	3rd order response, 18 dB/octave or 60 dB/decade	
80 kHz Low-pass Filter		
3 dB Cutoff		
Frequency	80 ±4 kHz	
Rolloff	3rd order response, 18 dB/octave or 60 dB/decade	

Table 1-1. Specifications (3 of 5)

SYSTEM SPECIFICATIONS (Cont'd)		
Characteristic	Performance Limits	Conditions
PLUG-IN AUDIO FILTERS 400 Hz Highpass Filter 3 dB Cutoff Frequency Rolloff	400 ±40 Hz 7th order response: 42 dB/octave or 140 dB/decade	
CCITT Weighting Filter Deviation from Ideal Response:	± 0.2 dB ± 1.0 dB ± 2.0 dB ± 3.0 dB	CCITT Recommendation P53 20 to 55°C, 80% relative humidity At 800 Hz 300 Hz to 3 kHz 50 Hz to 300 Hz, 3 kHz to 3.5 kHz 3.5 kHz to 5 kHz
CCIR Weighting Filter Deviation from Ideal Response:	± 2.0 dB ± 1.4 dB ± 1.0 dB ± 0.85 dB ± 0.7 dB ± 0.55 dB ± 0.5 dB ± 0.2 dB ± 0.4 dB ± 0.6 dB ± 0.8 dB ± 1.2 dB ± 1.65 dB ± 2.0 dB + 2.8/-inf dB	CCIR Recommendation 468-2, DIN 45405 20 to 55°C, 80% relative humidity 31.5 Hz to 63 Hz 63 Hz to 100 Hz 100 Hz to 200 Hz 200 Hz to 400 Hz 400 Hz to 800 Hz 800 Hz to 1 kHz 1 kHz to 6.3 kHz 6.3 kHz to 8 kHz 8 kHz to 9 kHz 9 kHz to 10 kHz 10 kHz to 12.5 kHz 12.5 kHz to 14 kHz 16 kHz to 20 kHz 20 kHz to 31.5 kHz at 31.5 kHz
C-MESSAGE Weighting Filter Deviation from Ideal Response:	± 2.0 dB ± 1.0 dB ± 0.2 dB ± 2.0 dB ± 3.0 dB	Per BSTM 41004 20 to 55°C, 80% relative humidity 60 Hz to 300 Hz 300 Hz to 3 kHz at 1 kHz 3 kHz to 3.5 kHz 3.5 kHz to 5 kHz
CCIR/ARM Weighting Filter Deviation from Ideal Response:	± 2.0 dB ± 1.4 dB ± 1.0 dB ± 0.85 dB ± 0.7 dB ± 0.55 dB ± 0.5 dB ± 0.2 dB	CCIR Recommendation 486-2, averaging responding meter, Dolby Labs bulletin No. 19/4. 20 to 55°C, 80% relative humidity 31.5 Hz to 63 Hz 63 Hz to 100 Hz 100 Hz to 200 Hz 200 Hz to 400 Hz 400 Hz to 800 Hz 800 Hz to 1 kHz 1 kHz to 6.3 kHz 6.3 kHz to 8 kHz

Table 1-1. Specifications (4 of 5)

SYSTEM SPECIFICATIONS (Cont'd)		
Characteristic	Performance Limits	Conditions
"A"-Weight Filter Deviation from Ideal Response:	± 0.4 dB	8 kHz to 9 kHz
	± 0.6 dB	9 kHz to 10 kHz
	± 0.8 dB	10 kHz to 12.5 kHz
	± 1.2 dB	12.5 kHz to 14 kHz
	± 1.65 dB	16 kHz to 20 kHz
	± 2.0 dB	20 kHz to 31.5 kHz
	+2.8/-inf dB	at 31.5 kHz
		IEC Recommendation 179 and ANSI S1.4, type 1 sound level meter
		20 to 55°C, 80% relative humidity
		20 Hz to 25 Hz
	25 Hz to 31.5 kHz	
	31.5 Hz to 50 Hz	
	50 Hz to 4 kHz	
	4 kHz to 6.3 kHz	
	6.3 kHz to 8 kHz	
	8 kHz to 10 kHz	
	10 kHz to 12.5 kHz	
	12.5 Hz to 26 kHz	
TEMPERATURE		
Operating	0° to 55°C	
Storage	-55° to 75°C	
INPUT TYPE	Balanced	Full differential
MAXIMUM INPUT	425V Peak	Differentially applied, or between either input and ground.
INPUT IMPEDANCE		
Resistance	100 kΩ ±1% 101 kΩ ±1%	Except in dc level mode In dc level mode only
Shunt Capacitance	<300 pF	Each terminal to ground
COMMON MODE REJECTION RATIO	>60 dB >45 dB >30 dB	20 Hz to 1 kHz, Vin < 2V 20 Hz to 1 kHz 20 Hz to 20 kHz
REMOTE OPERATION	HP-IB STD 488-1978 Compatibility Code: SH1, AH1, T5, TE0, L3, LE0, SR1, RL1, PPO, DC1, DT1, C0, E1	The Hewlett-Packard Interface Bus (HP-IB) is Hewlett-Packard Company's implementation of IEEE Std. 488-1978, "Digital Interface for Programmable Instrumentation". All functions except the line switch, the × 10 and ÷ 10 keys, and the low terminal float/ground switches are remotely controllable.
POWER REQUIREMENTS		
Line Voltage		
100, 120, 220, 240 Vac	+5%, -10%	48 to 66 Hz
100, 120 Vac	+5%, -10%	48 to 440 Hz

Table 1-1. Specifications (5 of 5)

SYSTEM SPECIFICATIONS (Cont'd)		
Characteristic	Performance Limits	Conditions
POWER DISSIPATION	100-A maximum	
CONDUCTED AND RADIATED INTERFERENCE (EMI)	MIL STD 461B	Conducted and radiated interface is within the requirements of methods CE03 and RE02 of MIL STD 461B and FTZ 526/527.
CONDUCTED AND RADIATED SUSCEPTIBILITY	MIL STD 461B-1980	Conducted and radiated susceptibility meets the requirements of methods CS01, CS02, and RS03 (1 volt/meter) of MIL STD 461B dated 1980.
NET WEIGHT	12.3 kg (27 lb) 16.4 kg (36 lb)	Net Shipping
DIMENSIONS (Full Envelope)		
Height	146 mm (5.75 in.)	Note: For ordering cabinet accessories, the module sizes are 5 1/4H x 1MW x 17D.
Width	425 mm (16.8 in.)	
Depth	462 mm (18.2 in.)	

Table 1-2. Supplemental Information

All parameters describe performance in automatic operation or with properly set manual controls.	
SOURCE	
<p>Frequency Switching Speed: <3 ms (does not include HP-IB programming time).</p> <p>Sweep Mode: Logarithmic sweep with up to 500 points/decade or 255 points total between entered start stop frequencies.</p> <p>Output Level Switching Speed: 20 ms (does not include HP-IB programming time).</p>	<p>Typical Source to Analyzer Isolation (Option 001 only) System distortion and noise can be degraded when driving low impedance loads (with source output impedance in the 50Ω mode) due to coupling from the source output to the analyzer input. See Figure 1-7 for the plot of various load impedances vs frequency.</p>
MEASUREMENT	
<p>SINAD Detection: True rms or rms calibrated average.</p> <p>Resolution: 0.01 dB for ratios >25 dB. For ratios <25 dB, the display is rounded to the nearest half dB to reduce digit flickering with noisy signals. (Full resolution is available by defeating this feature using Special Function 16.1.)</p> <p>Analog Meter* active in SINAD only and for SINAD ratios ≤18 dB (or ≤24 dB using Special Function 7.1). Accuracy: 1 dB typical.</p> <p>Tuning: notch filter is tuned to analyzer source frequency.</p> <p>Time to Return First Measurement: 1.5s typical.</p> <p>Measurement Rate: 2.0 readings/s typical.</p> <p>SIG/NOISE Resolution: Same as SINAD.</p> <p>Measurement Rate: One reading/second for rms and average detectors (one reading/2 seconds for quasi-peak detector).</p> <p>Detection: True rms or rms calibrated average or quasi-peak.</p> <p>Time of Return First Measurement: <2.5s typical.</p> <p>Operation: The Audio Analyzer displays the ratio of the input voltages as the internal source is switched on and off.</p> <p>DISTORTION 3 dB Measurement Bandwidth: 10 Hz to 500 kHz</p> <p>Detection: True rms or rms calibrated average.</p> <p>Displayed Resolution:</p> <ul style="list-style-type: none"> 0.0001% (<0.1% distortion) 0.001% (0.1% to 3% distortion) 0.01% (3% to 30% distortion) 0.1% (>30% distortion) <p>Time to Return First Measurement: 1.5s typical.</p> <p>Measurement Rate: 2 readings/s typical.</p>	<p>AC LEVEL AC Converter: True rms responding detection for signals with (crest factor of ≤3), rms calibrated average detection, quasi-peak detection (Meets CCIR 468-3 standard.)</p> <p>3 dB Measurement Bandwidth: >500 kHz.</p> <p>Time to Return First Measurement: <1.5s typical.</p> <p>Measurement Rate: 2.5 readings/s for rms and average detectors.</p> <p>Quasi-peak Detector Accuracy: (20 Hz to 20 kHz) ±6%.</p> <p>DC LEVEL: Time to Return First Measurement: <1.5s typical.</p> <p>Measurement Rate: 3 reading/s.</p> <p>FREQUENCY MEASUREMENT Measurement Rate: same as measurement mode selected.</p> <p>Counting Technique: reciprocal with 2 MHz time base.</p> <p>AUDIO FILTERS 400 Hz High-Pass Filter Rejection: >40 dB at 240 Hz; >65 dB at 60 Hz.</p> <p>REAR-PANEL INPUTS AND OUTPUTS Recorder Outputs: X Axis: 0 to 10 Vdc corresponding to the log of the oscillator frequency. Output Resistance: 1kΩ Y Axis: 0 to 10 Vdc corresponding to the displayed value and entered plot limits Output Resistance: 1 kΩ Pen Lift: TTL output</p> <p>Monitor Output: Output Impedance: 600Ω In ac level mode, provides scaled output of measured input signal In SINAD, distortion, and distortion level modes, provides scaled output of input signal with the fundamental removed.</p>
<p>* The meter has hysteresis. The trip point for the 24-dB range is > 18 dB, and the trip point for the 18-dB range is <17 dB.</p>	

Table 1-3. Recommended Test Equipment

Instrument Type	Critical Specifications	Suggested Model	Use*
AC Calibrator	Accuracy: 0.5%, 7 mV to 300V, 20 Hz to 100 kHz Flatness: $\pm 0.1\%$, 20 Hz to 100 kHz, $< 6V$ Output Current: 60 mA Frequency Accuracy: $\pm 5\%$	HP 745A and HP 746A, Datron 4200 or Fluke 5200A and Fluke 5215A	P,A
Audio Synthesizer	Frequency Range: 20 Hz to 500 kHz Frequency Accuracy: $\pm 4\text{ppm}$ Output Range: 0.6 Vrms into 50Ω . Output Attenuation Accuracy: $\pm 0.075\text{ dB}$, to 0.3 mV range	HP 3336C	P
Computing Controller	HP-IB compatibility as defined by IEE std. 488 and the identical ANS1 Std. MC1.1: SH1, AH1, T2, TEO, L2, LE0, SRO, PP0, DC0, DT0, and C1, 2, 3, 4, 5.	HP 9825A/ 98034A/98213A or HP 85B Opt. 007	C,T
DC Standard	Output Range: 3 mV to 300V Accuracy: $\pm 0.1\% \pm 0.3\text{mV}$	HP 7408 or Datron 4000 or Fluke 893AR	P
Digital Voltmeter	AC Accuracy: $\pm 0.2\%$ at 6 Vrms and 1 kHz DC Accuracy: $\pm 0.2\%$ at 1V	HP 3455A	A,T
Feedthrough Termination	Impedance: 50Ω Impedance Accuracy: $\pm 1\%$ Maximum Dissipation: 180 mW	HP 11048C	P
Feedthrough Termination	Impedance: 600Ω Impedance Accuracy: $\pm 1\%$ Maximum Dissipation: 100 mW	HP 11095A	P,A
Frequency Standard	Frequency: 0.1, 1, 2, 5, or 10 MHz Accuracy: $\pm 1\text{ ppm}$	House Standard	A
Oscilloscope	Bandwidth: $< 3\text{ dB}$ down 0 to 10 MHz Sensitivity: 5mV per division minimum Input Impedance: $1\text{ M}\Omega$ Triggering: Internal and External	HP 1740C	C,A,T
Power Supply	Output: to $\pm 15V$	HP 6215A	T
Resistor $100\text{k}\Omega$	Accuracy: $\pm 0.1\%$	HP 0698-7497	P
Signature Analyzer	Because the signatures documented are unique to a given signature analyzer type, no substitution of types is recommended.	HP 5005A	T
Test Oscillator	Frequency: 1 kHz Output: 30 Vpp	HP 3310A	T
HP 8904A Multifunction Synthesizer	Frequency Range: 20Hz to 350 kHz Frequency Accuracy: $\pm 4\text{ ppm}$ Output Range: 9V p-p into 50Ω Flatness: $\pm 0.09\text{dB}$, 20Hz to 350kHz	HP 8904A	P
20 dB Pad	Attenuation: 20 dB ($\pm 0.1\text{ dB}$) Frequency Range: 20 Hz to 100 kHz Impedance: 50Ω	Texscan FP-50 [20dB]	P
* C = Operator's Checks; P = Performance Tests; A = Adjustments; T = Troubleshooting			

Table 1-4. Service Accessories*

Accessory*	Specifications	Suggested Model
Digital Test/ Extender Board	No substitution recommended	HP 08903-60018
Extender Board	44 contacts (2 × 22), 3 required	HP 08901-60084
Extender Board	30 contacts (2 × 15), 2 required	HP 08901-60085
Foam Pad	Conductive polyurethane foam, 12 × 12 × 0.25 inches (nonmagnetic)	HP 4208-0094
* Refer to Section 8, paragraph 8-11, of this manual for application.		

NOTE

The performance tests, adjustments, and troubleshooting procedures are based on the assumption that the recommended test equipment is used. Substituting alternate test equipment may require modification of some procedures.

Section 2 INSTALLATION

2-1. INTRODUCTION

This section provides the information needed to install the Audio Analyzer. Included is information pertinent to initial inspection, power requirements, line voltage and fuse selection, power cables, interconnection, mating connectors, operating environment, instrument mounting, storage, and shipment. In addition, this section also contains the procedure for setting the internal HP-IB talk and listen address switches.

2-2. INITIAL INSPECTION

WARNING

To avoid hazardous electrical shock, do not perform electrical tests when there are signs of shipping damage to any portion of the outer enclosure (covers, panels, meters).

Inspect the shipping container for damage. If the shipping container or cushioning material is damaged, it should be kept until the contents of the shipment have been checked for completeness and the instrument has been checked mechanically and electrically. Procedures for checking electrical performance are given in Section 4. If the contents are incomplete, if there is mechanical damage or defect, or if the instrument does not pass the electrical performance test, notify the nearest Hewlett-Packard office. If the shipping container is damaged, or the cushioning material shows signs of stress, notify the carrier as well as the Hewlett-Packard office. Keep the shipping materials for the carrier's inspection.

2-3. PREPARATION FOR USE

Power Requirements

WARNING

To avoid the possibility of hazardous electrical shock, do not operate this instrument at line voltages greater than 126.5 Vac with line frequencies greater than 66 Hz. Leakage currents at these line settings may exceed 3.5 mA.

The Audio Analyzer requires a power source of 100, 120, 220, or 240 Vac, +5%, to -10%, 48 to 66 Hz single phase or 100 or 120 Vac, +5% to -10%, 48 to 440 Hz single phase. Power consumption is 100 VA maximum.

WARNING

This is a Safety Class I product (that is, provided with a protective earth terminal). An uninterruptible safety earth ground must be provided from the mains power source to the product input wiring terminals, power cord, or supplied power cord set. Whenever it is likely that this protection has been impaired, the product must be made inoperative and be secured against any unintended operation.

If this instrument is to be energized via an external autotransformer, make sure the autotransformer's common terminal is connected to the earthed pole of the power source.

Line Voltage and Fuse Selection**CAUTION**

BEFORE PLUGGING THIS INSTRUMENT into the Mains (line) voltage, be sure the correct voltage and fuse have been selected.

Verify that the line voltage selection card and the fuse are matched to the power source. Refer to Figure 2-1, *Line Voltage and Fuse Selection*.

Fast blow fuses may be ordered under HP part numbers 2110-0043, 1.5A for 100/120 Vac operation and 2110-0001, 1.0A for 220/240 Vac operation.

Power Cables**WARNING**

BEFORE CONNECTING THIS INSTRUMENT, the protective earth terminals of this instrument must be connected to the protective conductor of the (Mains) power cord. The Mains plug shall only be inserted in a socket outlet provided with a protective earth contact. The protective action must not be negated by the use of an extension cord (power cable) without a protective conductor (grounding).

This instrument is equipped with a three-wire power cable. When connected to an appropriate ac power receptacle, this cable grounds the instrument cabinet. The type of power cable plug shipped with each instrument depends on the country of destination. Refer to Figure 2-2 for the part numbers of the power cables available.

HP-IB Address Selection

WARNING

This task should be performed only by service trained persons who are aware of the potential shock hazard of working on an instrument with protective covers removed.

To avoid hazardous electrical shock, the line (Mains) power cable should be disconnected before attempting to change the HP-IB address.

In the Audio Analyzer, the HP-IB talk and listen addresses are selectable by an internal switch. The following procedure explains how the switches are to be set. Refer to Table 2-1 for a listing of the talk and listen addresses. The address is factory set for a Talk address of “\” and a listen address of “<”. (In binary, this is 11100; in decimal it is 28.) To change the HP-IB address, the top cover of the Audio Analyzer must be removed.

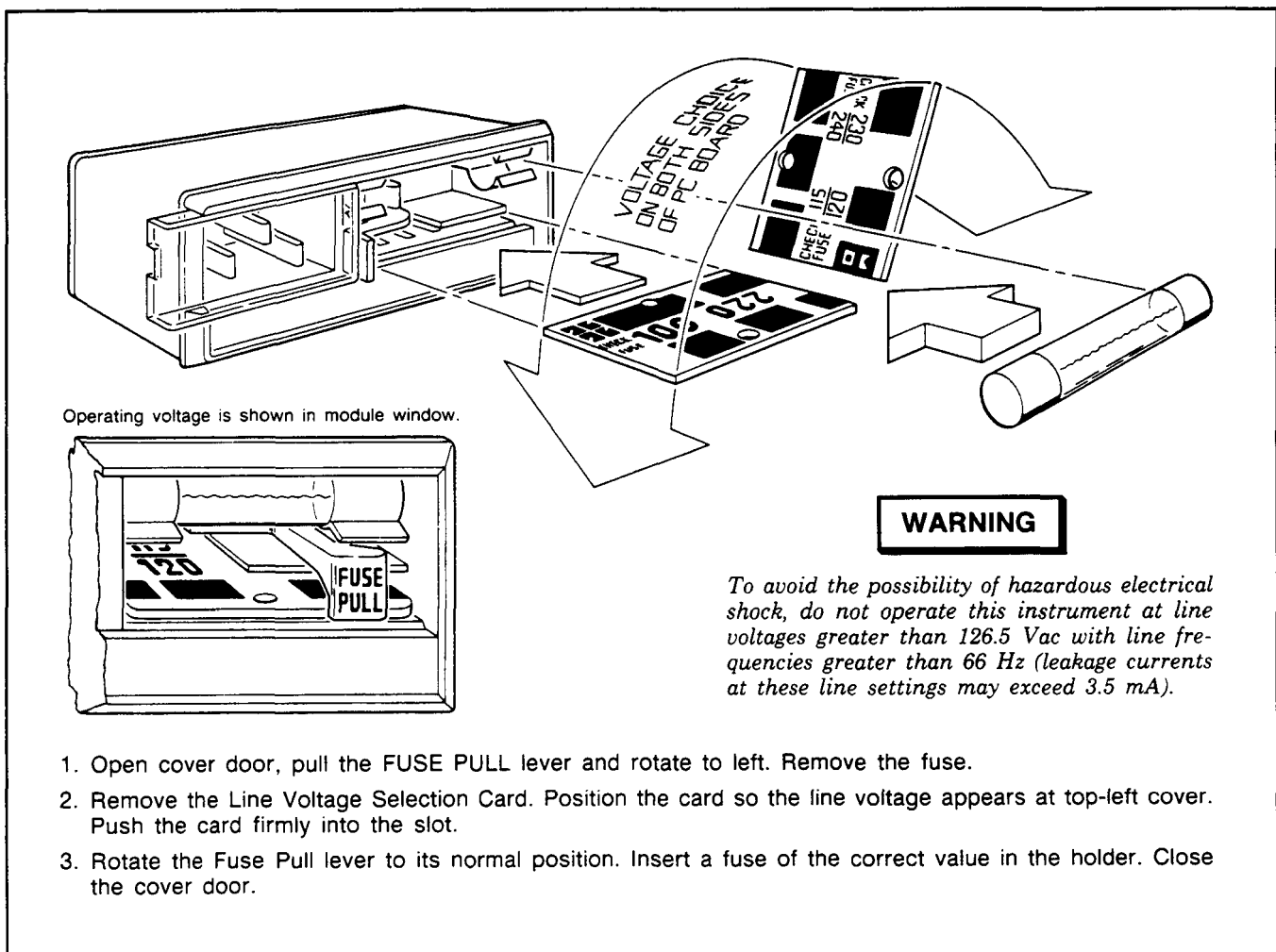
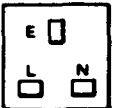

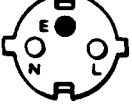

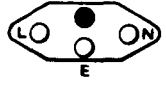
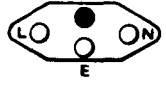
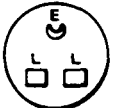



Figure 2-1. Line Voltage and Fuse Selection

Plug Type	Cable HP Part Number	C D	Plug Description	Cable Length (inches)	Cable Color	For Use In Country
250V 	8120-1351	0	90°/STR BS1363A*	90	Mint Gray	United Kingdom, Cyprus, Nigeria, Rhodesia, Singapore
	8120-1703	4	90°/90°	90	Mint Gray	
250V 	8120-1369	0	STR/STR	79	Gray	Australia, New Zealand
	8120-0696	4	NZSS198/ASC112* STR/90°	80	Gray	
250V 	8120-1689	7	STR/STR*	79	Mint Gray	East and West Europe, Saudi Arabia, Egypt, (unpolarized in many nations)
	8120-1692	2	STR/90°	79	Mint Gray	
125V  100V (Same plug as above)	8120-1378	1	STR/STR NEMA5-15P*	80	Jade Gray	United States, Canada, Mexico, Phillipines, Taiwan U.S./Canada
	8120-1521	6	STR/90°	80	Jade Gray	
	8120-1751	1	STR/STR	90	Jade Gray	
250V 	8120-4753	2	STR/STR	90	Dark Gray	Japan only
	8120-4754	3	STR/90°	90	Dark Gray	Japan only
	8120-2104	3	STR/STR SEV1011 1959-24507 Type 12	79	Gray	Switzerland
250V 	8120-2296	4	STR/90°	79	Gray	
	8120-3997	4	STR/90°	177	Gray	
	8120-0698	6	STR/STR NEMA6-15P	90	Black	
250V 	8120-2956	3	90°/STR	79	Gray	Denmark
	8120-2957	4	90°/90°			
	8120-3997	4	STR/STR			
250V 	8120-4211	7	STR/STR*IEC83-B1	79	Black	South Africa, India
	8120-4600	8	STR/90°	79	Gray	
250V 	8120-1860	6	STR/STR*CEE22-V1 (Systems Cabinet Use)	59	Jade Gray	
	8120-1575	0	STR/STR	31	Jade Gray	
	8120-2191	8	STR/90°	59	Jade Gray	
	8120-4379	8	90°/90°	80	Jade Gray	

* Part number shown for plug is industry identifier for plug only. Number shown for cable is HP Part Number for complete cable including plug. E = Earth Ground; L = Line; N = Neutral; STR = Straight

Figure 2-2. Power Cable and Mains Plug Part Numbers

To set the HP-IB Address on the Audio Analyzer:

1. Disconnect the line (Mains) power cable.
2. Remove any HP-IB cables or connectors from the HP-IB connector.
3. Remove the Audio Analyzer top cover.
 - a. Remove the two plastic feet from the rear of the top cover by removing the panhead Pozidriv screw within each foot.
 - b. Unscrew the Pozidriv screw at the center of the rear edge of the top cover. This is a captive screw and will cause the top cover to pull away from the front frame.
 - c. Lift off the top cover.
 - d. Locate the HP-IB address switch accessible through a hole near the center rear of the internal shield cover.
4. Use a pencil to set the switches to the desired HP-IB address and Talk Only (TON) or Listen Only (LON) condition. The switch is illustrated in Figure 2-3. Facing the board, the left hand switch (marked with a "5") is the most significant address bit (A5 in Table 2-1). Setting a switch toward the printed circuit board places it in its "1" position. If the TON and LON switches are both set to "1", the Talk Only setting will override. If the address switches and the TON switch are all set to "1", the Audio Analyzer will output one byte (the status byte) each measurement cycle. (Setting all switches to "1" defeats HP-IB operation.)
5. Reinstall the top cover by reversing the procedure in step c above.
6. Connect the line (Mains) power cable to the Line Power Module and reconnect the HP-IB cable to the HP-IB connector.
7. To confirm the setting, refer to HP-IB Address in the *Detailed Operating Instructions* in Section 3 of this manual.

Interconnections

Interconnection data for the Hewlett-Packard Interface Bus is provided in Figure 2-4.

Mating Connectors

Interface Connector. The HP-IB mating connector is shown in Figure 2-4. Note that two securing screws are metric.

Coaxial Connectors. Coaxial mating connectors used with the Audio Analyzer should be the 50 Ω BNC male connectors.

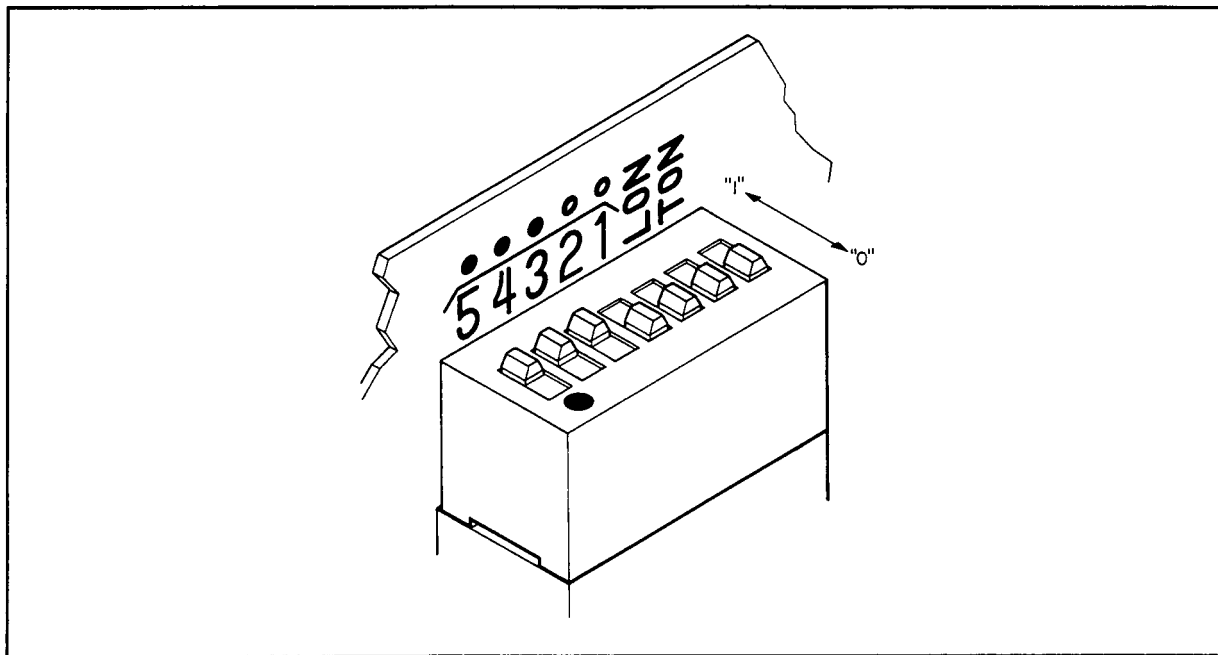

Figure 2-3. HP-IB Address Switch Shown as Set by the Factory.
The Address Shown is 11100 in Binary with Both Talk Only and Listen Only Off.

2-4. OPERATING ENVIRONMENT

The operating environment should be within the following limitations:

Temperature	0° to +55°C
Humidity	<95% relative
Altitude	<4570 meters (15 000 feet)

Bench Operation

The instrument cabinet has plastic feet and foldaway tilt stands for convenience in bench operation. (The plastic feet are shaped to ensure self aligning of the instruments when stacked.) The tilt stands raise the front of the instrument for easier viewing of the front panel.

Rack Mounting

WARNING

The Audio Analyzer is heavy for its size (12.3 kg, 27 lb). Care must be exercised when lifting to avoid personal injury. Use equipment slides when rack mounting.

CAUTION

DO NOT BLOCK the ventilation holes in the bottom panel. Since this instrument does not use a cooling fan, it is important that good ventilation be provided. Allow for 1 to 2 inches clearance around the bottom panel.

Table 2-1. Allowable HP-IB Address Codes 

Address Switches					Talk Address Character	Listen Address Character	Decimal Equivalent
A5	A4	A3	A2	A1			
0	0	0	0	0	@	SP	0
0	0	0	0	1	A	!	1
0	0	0	1	0	B	"	2
0	0	0	1	1	C	#	3
0	0	1	0	0	D	\$	4
0	0	1	0	1	E	%	5
0	0	1	1	0	F	&	6
0	0	1	1	1	G	'	7
0	1	0	0	0	H	(8
0	1	0	0	1	I)	9
0	1	0	1	0	J	•	10
0	1	0	1	1	K	+	11
0	1	1	0	0	L	,	12
0	1	1	0	1	M	—	13
0	1	1	1	0	N		14
0	1	1	1	1	O	/	15
1	0	0	0	0	P	0	16
1	0	0	0	1	Q	1	17
1	0	0	1	0	R	2	18
1	0	0	1	1	S	3	19
1	0	1	0	0	T	4	20
1	0	1	0	1	U	5	21
1	0	1	1	0	V	6	22
1	0	1	1	1	W	7	23
1	1	0	0	0	X	8	24
1	1	0	0	1	Y	9	25
1	1	0	1	0	Z	:	26
1	1	0	1	1	[;	27
1	1	1	0	0	\	<	28
1	1	1	0	1]	=	29
1	1	1	1	0	^	>	30

Rack mounting information is provided with the rack mounting kits. If the kits were not ordered with the instrument as options, they may be ordered through the nearest Hewlett-Packard office. Refer to paragraph 1-13, *Mechanical Options*, in Section 1.

2-5. STORAGE AND SHIPMENT

Environment

The instrument should be stored in a clean, dry environment. The following environmental limitations apply to both storage and shipment:

Temperature -55°C to +75°C
 Humidity <95% relative
 Altitude 15 300 meters (50 000 feet)

Packaging

Original Packaging. Containers and materials identical to those used in factory packaging are available through Hewlett-Packard offices. If the instrument is being returned to Hewlett-Packard for servicing, please fill out one of the blue tags located at the end of this manual. Include on the tag the type of service required, return address, model number, and full serial number and attach it to the instrument. Mark the container "FRAGILE" to assure careful handling. In any correspondence refer to the instrument by model number and full serial number.

Other Packaging. The following general instructions should be used for re-packaging with commercially available materials:

1. Wrap the instrument in heavy paper or plastic. (If shipping to a Hewlett-Packard office or service center, complete one of the blue tags mentioned above and attach it to the instrument.)
2. Use a strong shipping container. A doublewall carton made of 1.9 MPa (275 psi) test material is adequate.
3. Use enough shock-absorbing material (75 to 100 mm layer; 3 to 4 inches) around all sides of instrument to provide a firm cushion and prevent movement in the container. Protect the front panel with cardboard.
4. Seal the shipping container securely.
5. Mark the shipping container "FRAGILE" to assure careful handling.

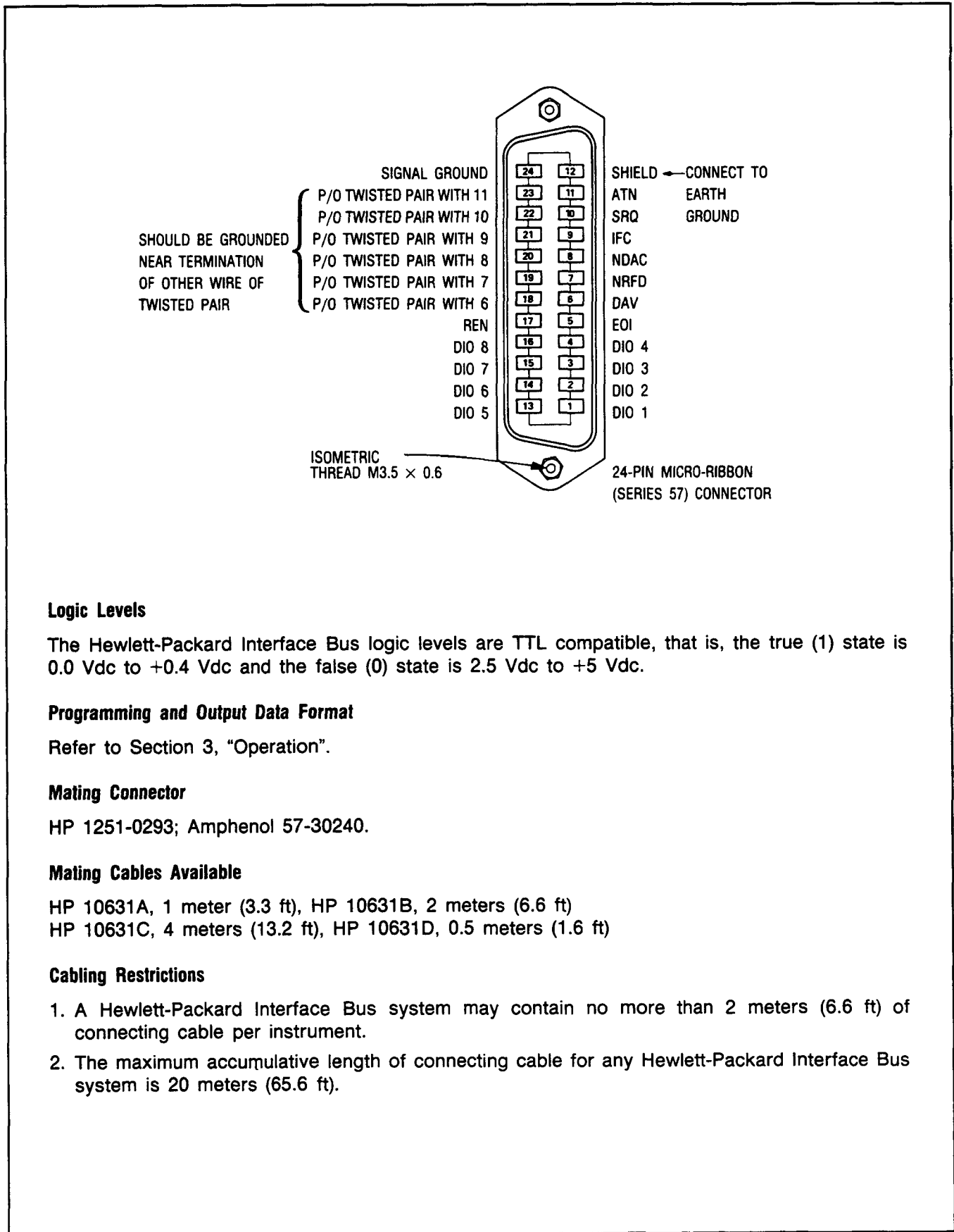

Logic Levels

The Hewlett-Packard Interface Bus logic levels are TTL compatible, that is, the true (1) state is 0.0 Vdc to +0.4 Vdc and the false (0) state is 2.5 Vdc to +5 Vdc.

Programming and Output Data Format

Refer to Section 3, "Operation".

Mating Connector

HP 1251-0293; Amphenol 57-30240.

Mating Cables Available

HP 10631A, 1 meter (3.3 ft), HP 10631B, 2 meters (6.6 ft)
 HP 10631C, 4 meters (13.2 ft), HP 10631D, 0.5 meters (1.6 ft)

Cabling Restrictions

1. A Hewlett-Packard Interface Bus system may contain no more than 2 meters (6.6 ft) of connecting cable per instrument.
2. The maximum accumulative length of connecting cable for any Hewlett-Packard Interface Bus system is 20 meters (65.6 ft).

Figure 2-4. Hewlett-Packard Interface Bus Connection

Section 3 OPERATION

3-1. INTRODUCTION

General

This section provides complete operating information for the Audio Analyzer. Included in this section are descriptions of all front- and rear-panel controls, connectors, and indicators, remote and local operator's checks, operating instructions, and operator's maintenance.

Operating Characteristics

Table 3-1 briefly summarizes the major operating characteristics of the Audio Analyzer. The table is not intended to be an in-depth listing of all operations and ranges but gives an idea of the instrument's capabilities. For more information on the Audio Analyzer capabilities, refer to the description in Section 1; Table 1-1, *Specifications*; and Table 1-2, *Supplemental Information*. For information on HP-IB capabilities, refer to the summary contained in Table 3-3, *Message Reference Table*.

Turn-On Procedure

WARNING

Before the Audio Analyzer is switched on, all protective earth terminals, extension cords, auto-transformers, and devices connected to it should be connected to a protective earth socket. Any interruption of the protective earth grounding will cause a potential shock hazard that could result in personal injury. In addition, verify that a common ground exists between the unit under test and the Audio Analyzer prior to energizing either unit.

For continued protection against fire hazard, replace the line fuse with a 250V fast blow fuse of the same rating. Do not use repaired fuses or short circuited fuseholders.

CAUTION

Before the Audio Analyzer is switched on, it must be set to the voltage of the power source, or damage to the instrument may result.

Do not allow the voltage at the SOURCE OUTPUT HIGH or LOW terminal to be greater than +10V or less than -10V (ac + dc) or damage to the instrument may result.

If the Audio Analyzer is already plugged in, set the LINE switch to ON. If the power cable is not plugged in, follow these instructions.

1. Check that the line voltage setting matches the power source (see Figure 2-1).
2. Check that the fuse rating is appropriate for the line voltage used (see Figure 2-1). Fuse Ratings are given under Operator's Maintenance.
3. Plug in the power cable.
4. Set the LINE switch to ON.

NOTE

When the LINE switch is set to ON, all front-panel indicators will light for approximately 4 seconds after which the instrument is ready to be operated.

Local Operation

Information covering front-panel operation of the Audio Analyzer is given in the sections described below. To rapidly learn the operation of the instrument, begin with Simplified Operation and Operator's Checks. Once familiar with the general operation of the instrument, use the Detailed Operating Instructions for in-depth and complete information on operating the Audio Analyzer.

Simplified Operation. Simplified Operation provides a quick introduction to front-panel operation of the Audio Analyzer. It is designed to rapidly orient the new user with basic procedures and therefore is not an exhaustive listing of all Audio Analyzer functions. However, an index to the Detailed Operating Instructions appears in Table 3-2 to guide the operator to the more complete discussion of the topic of interest.

Panel Features. Front-panel controls, indicators, and connectors are illustrated and described in Figure 3-1. (For Option 001, the INPUT and OUTPUT HIGH and LOW connectors are located on the rear panel.) Rear-panel features are shown in Figure 3-2. This figure provides a good quick reference for rear-panel signal levels and also includes the impedance at the rear-panel connections.

Detailed Operating Instructions. The Detailed Operating Instructions provide the complete operating reference for the Audio Analyzer user. The instructions are organized alphabetically by subtitle. Not only do the instructions contain information on the various measurements that can be made (listed under titles such as AC Level, Distortion, etc.) but there are also individual discussions of nearly all controls, inputs, and outputs, (for example, Amplitude, Monitor, etc.). Also included are instructions for using the many User Special Functions (for example, Hold Settings, Error Disable, Special Functions, etc.). The Detailed Operating Instructions are indexed by function in Table 3-2.

Each section contains a general description which covers signal levels, ranges, and other general information. Following the description are related procedures, an operating example, the relevant HP-IB codes, front-panel indications, and, where pertinent, a description of the technique the Audio Analyzer uses to make the measurement. At the end of each discussion are comments intended to guide the user away from measurement pitfalls and to help get the most out of the Audio Analyzer. Also included are references to other sections which contain related information. The Detailed Operating Instructions are designed so that both casual and sophisticated users can rapidly find at one location all the information needed to apply the instrument to the task at hand.

Operating Information Pull-Out Cards. The Operating Information pull-out cards are flexible plastic reference sheets attached to the Audio Analyzer by a tray located below the front-panel. They contain a complete listing of HP-IB codes and data and error output formats, Error codes, and User Special Functions. The cards are intended to be a reference for the user who already has a basic understanding of front-panel operation.

Supplemental Information. In addition to the information described above several other discussions pertinent to the operating of the Audio Analyzer to its fullest capabilities are contained in Section 1 of this manual. *Principles of Operation for a Simplified Block Diagram* is a fundamental description of what the Audio Analyzer is and how it works. This information supplements the block diagrams given in the Detailed Operating Instructions and provides a basis for applying the Audio Analyzer to various measurement situations. *Basics of Audio Measurements* is a general discussion of audio measurements. It is intended to provide an intuitive understanding of audio measurements rather than an in-depth mathematical analysis.

Remote Operation

The Audio Analyzer is capable of remote operation via the Hewlett-Packard Interface Bus (HP-IB). Instructions pertinent to HP-IB operation cover all considerations and instructions specific to remote operation including capabilities, addressing, input and output formats, the status byte, and service requests. At the end of the discussion is a complete summary of all codes and formats.

In addition to the section described above, information concerning remote operation appears in several other locations. Address setting is discussed in Section 2 *Installation*. A summary of HP-IB codes and output formats appear on one of the Operating Information pull-out cards, and numerous examples of program strings appear throughout the *Detailed Operating Instructions* described under Local Operation above.

3-2. OPERATOR'S CHECKS

Operator's checks are procedures designed to verify the proper operation of the Audio Analyzer's main functions. Two procedures are provided as described below.

Basic Functional Checks. This procedure requires an oscilloscope and interconnecting cables. It assumes that most front-panel controlled functions are being properly executed by the Audio Analyzer.

HP-IB Functional Checks. This series of procedures require an HP-IB compatible computing controller and an HP-IB interface and connecting cable. The HP-IB Functional Checks assume that front-panel operation has been verified (for example, by performing the Basic Functional Checks). The procedures check all of the applicable bus messages summarized in Table 3-3.

Operator's Maintenance

WARNING

For continued protection against fire hazard, replace the line fuse with a 250V fast blow fuse of the same rating only. Do not use repaired fuses or short-circuited fuseholders.

The only maintenance the operator should normally perform is the replacement of the primary power fuse located within the Line Power Module (A14). For instructions on how to change the fuse, refer to Figure 2-1, steps 1 and 3.

Fuses may be ordered by looking up the reference designator F1 in Section 6, Replaceable Parts, and ordering the correct part number for 100/120 Vac or for 220/240 Vac operation (both fuses are 250V fast blow).

NOTE

If the instrument does not operate properly and is being returned to Hewlett-Packard for service, please complete one of the blue repair tags located at the end of this manual and attach it to the instrument. Refer to Paragraph 2-7 in Section 2 for packaging instructions.

Table 3-1. Operating Characteristics Summary

Operating Parameter	Capabilities
Output Limits	Frequency: 20 Hz to 100 kHz Level: 0.6 mV to 6V (open circuit). Impedance: 50Ω or 600Ω selectable, floating output can be selected.
Input Limits	Frequency: 20 Hz to 100 kHz (150 kHz, ac level) Level: ≈0 to 300V ac or dc. Impedance: 100 kΩ (except dc level); 101 kΩ (dc level); floating input can be selected.
Measurements (including counter frequency measurements except in DC Level)	AC Level: ≈0 to 300 Vac; 20 Hz to 150 kHz. Full range display from .3000 mV to 300.0V in seven ranges. DC Level: 0 to 300 Vdc. Full range display from 4.000V to 300.0V in four ranges. Sinad: 50 mV to 300V; 20 Hz to 100 kHz. Display range 0 to 99.99 dB. SINAD meter marked for EIA and CEPT readings. SIG/NOISE: 50 mV to 300V; 50 Hz to 100 kHz. Display range 0 to 99.99 dB. DISTN: 50 mV to 300V; 20 Hz to 100 kHz. Display range -99.99 to 0 dB DISTN LEVEL: Similar to ac level except that the notch filter is used in the measurement
Detection	True rms, average detection, or Quasi-Peak (output Detector only).
Swept Measurements	All measurements can be swept and frequency vs. measurement result can be plotted using an external X-Y recorder.
Audio Filters	HP/BP Filter - Up to two of the following HP/BP filters may be installed: HIGH PASS 400 Hz: 400 ±40 Hz (3 dB cutoff) CCITT Weighting: CCITT Recommendation P53. CCIR Weighting: CCIR 468-2 C-MESSAGE: BSTM #41009 FIG 1 A-Weighting: ANSI S1.4, IEC rec 179 CCIR/ARM Weighting: CCIR 468-2, Dolby Labs LP FILTER Low PASS 30 kHz: 30±2 kHz (3 dB cutoff). 80 kHz: 80 ±4 kHz (3 dB cutoff).
Manual Operation	Output level and frequency, input attenuation, ratio, log/linear, display resolution, measurement selection, and many other operations can be manually controlled.
Remote Operation	All Audio Analyzer operations except the LINE switch, two FLOAT switches, and the ÷10 and × 10 FREQ/AMPT ADJUST keys can be controlled via the Hewlett-Packard Interface Bus.

3-3. FRONT-PANEL FEATURES

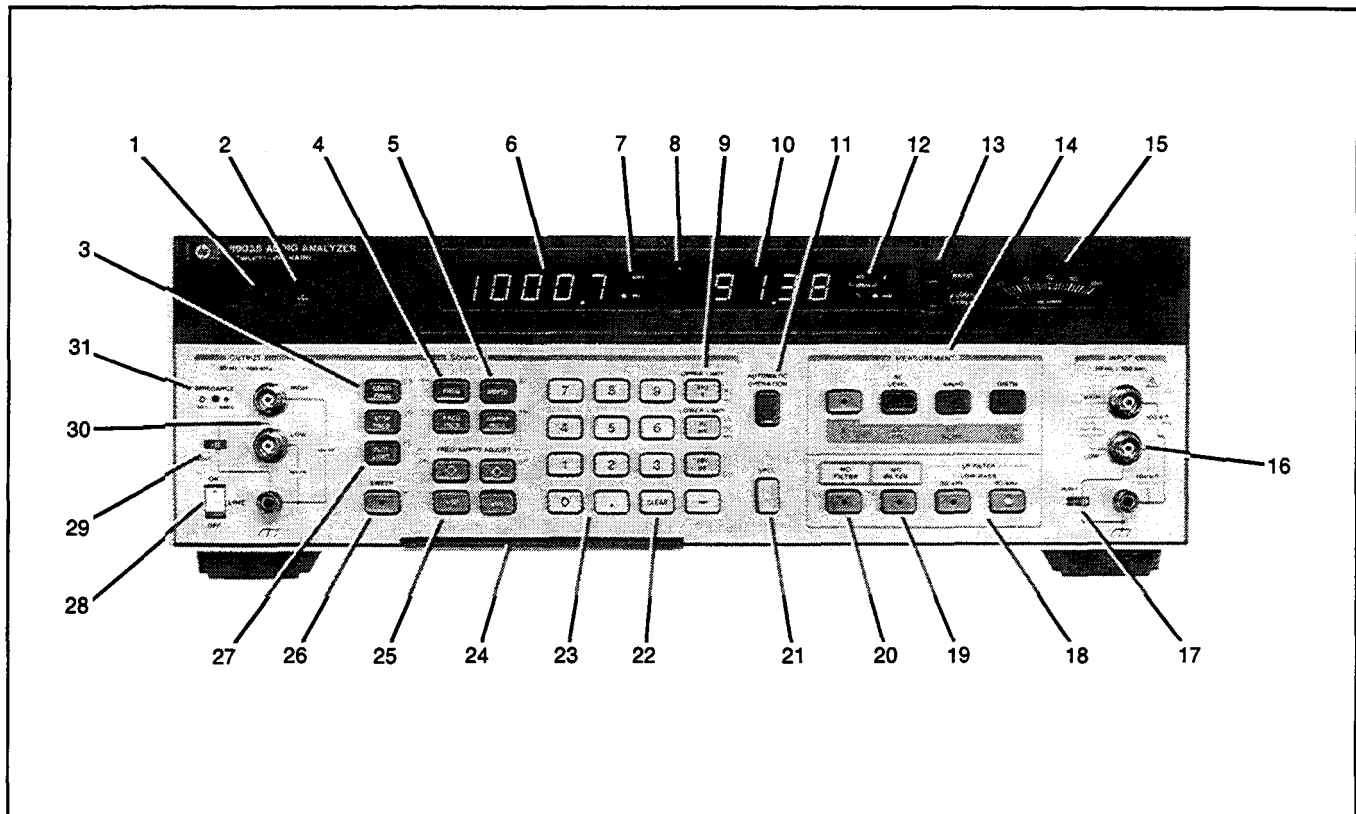

Figure 3-1. Front-Panel Features

1. **HP-IB Annunciators** indicate remote operation status.
2. **LCL** (local) key returns the Audio Analyzer to keyboard control from remote (HP-IB) control.
3. **START** and **STOP FREQ** keys display or initiate entry of the start and stop frequencies of the sweep.
4. **FREQ** and **FREQ INCR** keys display or initiate entry of the frequency and frequency increment of the source.
5. **AMPTD** and **AMPTD INCR** keys display or initiate entry of the amplitude or amplitude increment of the source.
6. The two **Numeric Displays** show the frequency, measurement results, numeric key entries, error codes, or instrument or Special Function status.
7. **Frequency Display Annunciators** indicate the frequency units.
8. **MEASUREMENT CYCLE** indicator blinks after each measurement cycle.
9. **Unit keys** select units and complete manual data entry.
10. **AUTOMATIC OPERATION** key switches instrument to automatic (i.e., functions allowed to automatically range as appropriate).
11. **Measurement Display Annunciators** indicate the measurement result units.
12. **RATIO** key causes measurements to be displayed in % or dB relative to a reference.
13. **LOG/LIN** key causes results to be displayed in logarithmic or linear units.

14. **MEASUREMENT** keys command the Audio Analyzer to make and display the selected measurement.
15. **SINAD** meter is marked for EIA and CEPT sensitivity and selectivity readings (when within limits).
16. **INPUT** couples measurement signal into the instrument.
17. **FLOAT** switch provides floating input when required.
18. **LOW PASS** 30 kHz and 80 kHz filters reject high frequency noise.
19. **RIGHT-MOST OPTIONAL PLUG-IN FILTER** key selects the filter that is installed in the right-most filter slot. The CCITT WEIGHTING (band pass) FILTER (Option 051) weights receiver testing according to CCITT recommendation P53.
20. **LEFT-MOST OPTIONAL PLUG-IN FILTER** key selects the filter installed in the left-most filter slot. The 400 Hz HIGH PASS filter (option 010) rejects line related noise and squelch tones.
21. **SPCL** key completes entry of Special Function codes for accessing instrument operations additional to those having dedicated front-panel keys. Also permits reading of Special Function or hardware status.
22. **CLEAR** key erases keyboard entries in progress. In remote hold, CLEAR initiates a Trigger with Settling measurement cycle.
23. **Numeric** keys are used for manual entry of frequency, amplitude, limits, RATIO references, and selection of Special Functions.
24. **OPERATING INFORMATION** pullout cards are quick operating references that list Special Function, HP-IB, and error codes.
25. **FREQ/AMPTD ADJUST** keys change the source frequency or amplitude in specified increments. The $\times 10$ and $\div 10$ keys modify the specified increment.
26. **SWEEP** key initiates or restarts a logarithmic sweep between the START and STOP FREQ settings.
27. **PLOT LIMIT** key displays or initiates entry of plotter limits.
28. **LINE** switch applies power to the Audio Analyzer when set to ON.
29. **FLOAT** switch provides floating output when required.
30. **SOURCE OUTPUT** provide 0.6 mV to 6V (open circuit), 20 Hz to 100 kHz signal.
31. **IMPEDANCE** light indicates 50Ω source output impedance if lit, 600Ω when off.

SIMPLIFIED OPERATION

SOURCE FREQUENCY AND AMPLITUDE

Frequency

To set source frequency to 500 Hz,

press:

Amplitude:

To set source amplitude to 3V,

press:

Frequency Increment

To set frequency increment step to 10 Hz,

press:

Amplitude Increment

To set amplitude increment step to 200 mV,

press:

Stepping Increments

To step frequency up 10 Hz (as set above),

press: (holding down causes frequency to move up slowly in 10 Hz steps).

MEASUREMENT

For ac level, SINAD, or distortion measurements,

press: or or

For dc level, signal-to-noise, or distortion level measurements,

press: or or

FILTERS

HP/BP Filter

To activate any of the optional plug-in filters, press:

CORRESPONDING FILTER



LP Filter

To activate the LOW PASS 30 kHz filter, press:

LOW PASS 30 kHz



SWEEP

Start Frequency

To set the start frequency of the sweep to 100 Hz,

press: .

Stop Frequency

To set the stop frequency of the sweep to 10 kHz, press: .

Starting the Sweep

To start the frequency sweep, press: .

RATIO and LOG/LIN

RATIO

To set the displayed measurement as the ratio reference, press: .

LOG/LIN

To convert from linear to logarithmic (or from logarithmic to linear) measurement units,

press: .

Measurement Mode	RATIO on		RATIO off	
	LIN	LOG	LIN	LOG
AC LEVEL	%	dB	V or mV	dBm into 600Ω
DC LEVEL	%	dB	V or mV	dBm into 600Ω
SINAD	%	dB	%	dB
SIG/NOISE	%	dB	%	dB
DISTN	%	dB	%	dB
DISTN LEVEL	%	dB	V or mV	dBm into 600Ω

NOTE

During power up, the Audio Analyzer is initialized and set to AUTOMATIC OPERATION.

NOTE

Some delays may be noted when pressing keys during sweeps with an x-y recorder enabled. These delays allow the pen to lift before moving. However, the keys are recognized and it is unnecessary to hold them down while waiting for the Audio Analyzer to respond.

Table 3-2. Detailed Operating Instruction Table of Contents (functional Listing) ¹

Section	Page	Section	Page
Source		Inputs and Outputs  ²	
Amplitude	3-44	Float	3-72
Display Source Setting	3-57	Monitor	3-90
Frequency	3-74	X-Y Recording	3-137
Increment	3-83		
Output Impedance	3-95	Special Functions	
Measurements		Detector Selection	3-53
AC Level	3-42	Display Level in Watts	3-55
Common Mode	3-47	Display Source Setting	3-57
DC Level	3-50	Error Disable	3-62
Detector Selection	3-53	Hod Decimal Point	3-76
Distortion	3-58	Hold Settings	3-78
Distortion Level	3-60	HP-IB Address	3-80
Signal-to-Noise	3-118	Input Level Range (DC Level)	3-86
SINAD	3-120	Input Level Range (Except DC Level)	3-88
Filters		Notch Tune	3-93
Filters (Low-Pass, High-Pass, Bandpass)	3-68	Post-Notch Detector Filtering	3-100
Notch Tune	3-93	Post Notch Gain	3-102
Post-Notch Detector Filtering	3-100	Read Display to HP-IB	3-114
Sweep and X-Y Recording		Service Request Condition	3-116
Plot Limit	3-98	Special Functions	3-123
Sweep	3-130	Sweep Resolution	3-133
Sweep Resolution	3-133	Time Between Measurements	3-136
Time Between Measurements	3-136	HP-IB	
X-Y Recording	3-137	HP-IB Address	3-80
Data Manipulation		Rapid Frequency Count	3-104
Display Level in Watts	3-55	Service Request Condition	3-116
Hold Decimal Point	3-76	Rapid Source	3-107
RATIO and LOG/LIN	3-111	Read Display to HP-IB	3-114
Errors		Miscellaneous	
Error Disable	3-62	Automatic Operation	3-46
Error Message Summary	3-64	Default Conditions and Power up Sequence	3-52
		Float	3-72

¹ The detailed operating instructions are arranged in alphabetical order at the end of the Operation section.

²  Do not apply more than 300 Vrms to the INPUT.

3-4. REAR-PANEL FEATURES

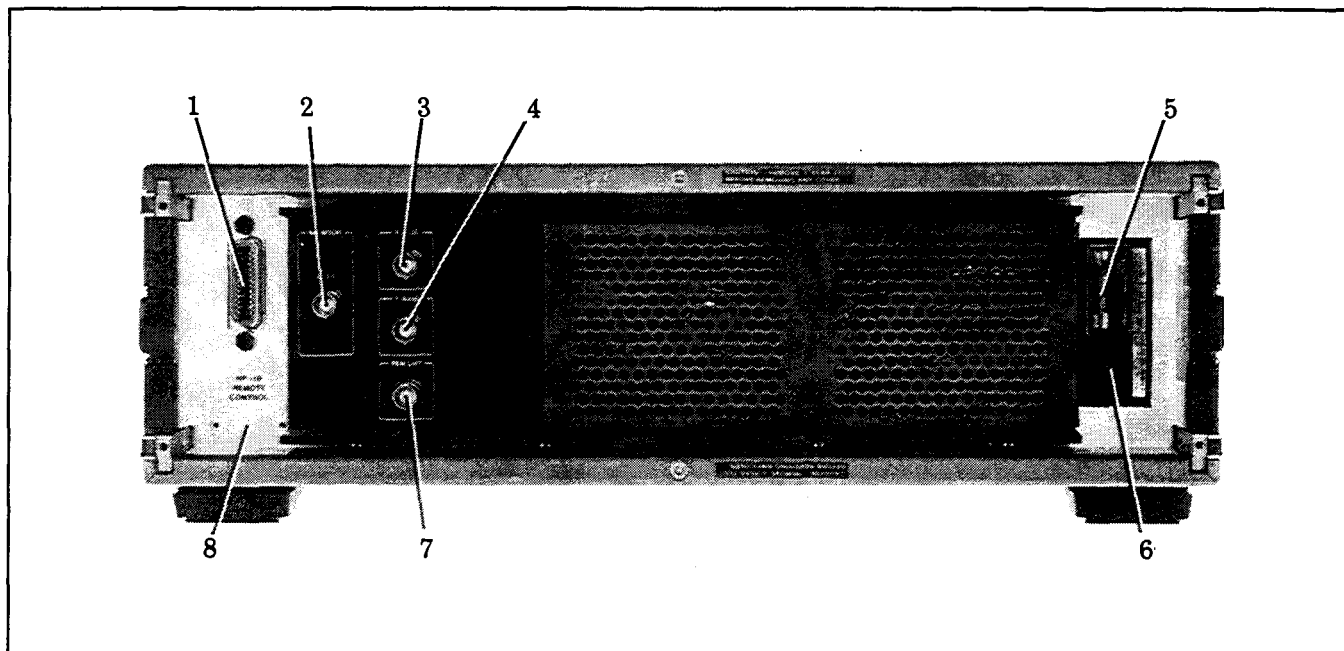

Figure 3-2. Rear Panel Features

1. **HP-IB Connector.** connects the Audio Analyzer to Hewlett-Packard Interface Bus for remote operations. when in remote mode, the front-panel REMOTE annunciator lights.
2. **MONITOR.** In ac level mode, provides a scaled voltage output representing the input signal. In SINAD, distortion, and distortion level modes, provides a scaled voltage output of the input signal with the fundamental removed. Output impedance is 600Ω .
3. **X AXIS.** A scaled voltage output representing the log of the oscillator frequency range from the start to the stop frequencies. The start frequency equals 0V and the stop frequency equals 10V. Output impedance is $1\text{ k}\Omega$.
4. **Y AXIS.** A scaled voltage output representing the amplitude range from the lower to the upper limit of the plot. The lower limit equals 0V. The upper limits equals 10V. Output impedance is $1\text{ k}\Omega$.
5. **Fuse.** 1.5A rating for 100/120 Vac. 1.0A rating for 220/240 Vac.
6. **Line Power Module.** permits operation from 100, 120, 220, or 240 Vac. The number visible in window indicates nominal line voltage to which instrument must be connected (see Figure 2-1). Center conductor is safety earth ground.
7. **PEN LIFT.** TTL compatible output that is used for pen control. TTL high signal is used to lift pen.
8. **Serial Number Plate.** First four numbers and letter comprise the prefix that denotes the instrument configuration. The last five digits form the suffix that is unique to each instrument.

3-5. BASIC FUNCTIONAL CHECKS

Description

Using only an oscilloscope, the overall operation of the Audio Analyzer is verified.

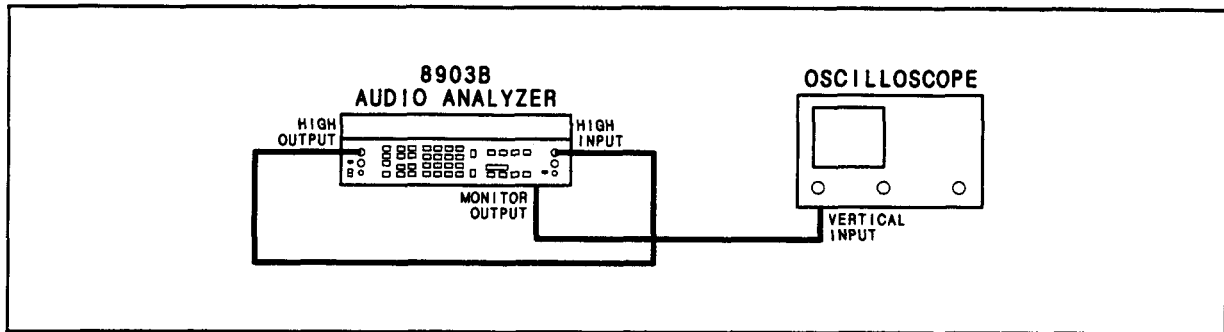

Figure 3-3. Basic Functional Checks Setup

Equipment

Oscilloscope HP 1740A

PROCEDURE

Preliminary Check

1. Remove any cables from the Audio Analyzer's INPUT or OUTPUT. Set the LINE switch to OFF, then back to ON and note that the front-panel LED annunciators, display segments and decimal points, and key lights turn on. All LEDs should light for approximately three seconds.
2. After the turn-on sequence, the left display should show 0.000 kHz and the right display should show a low flickering value in mV. In addition, the measurement cycle annunciator in the upper left-hand corner of the right display should be blinking and the AC LEVEL and LOW PASS 80 kHz key lights should light.
3. Connect a BNC-to-BNC cable between the HIGH OUTPUT and the HIGH INPUT. See Figure 3-3. Set both FLOAT switches to the grounded position. Set impedance to 50 Ω by keying in 47.1 then pressing the SPCL button. The SPCL key light should be lit.
4. Connect the oscilloscope to the MONITOR output on the rear panel. See Figure 3-3.

AC Level and Output Level Check

5. Press AMPTD. While the key is pressed, 0.00 mV should show in the right display.
6. Press 1 and V to set the amplitude to 1 Vrms. The left display should show between 960 and 1040 Hz (the frequency the source is set to during power up). The right display should show between 0.960 and 1.040V. The oscilloscope should show a 1 kHz (1 ms period) sine wave of approximately 7 Vpp.
7. Press RATIO. The RATIO key light should light. The right display should show 100%.

NOTE

In this and the following steps, the displays may vary a few least-significant digits.

8. Key in 5.2 SPCL to measure ac level with the average-responding detector. The SPCL key light should remain lit. The right display should remain at approximately 100%.
9. Key in 5.0 SPCL to measure ac level again with the rms-responding detector. Set impedance by 600Ω by keying in 47.0 then pressing the SPCL button. The SPCL key light should extinguish. The right display should drop by approximately 0.6% (down to approximately 99.4%).
10. Set the impedance back to 50Ω by keying in 47.1 then pressing the SPCL button. Set the OUTPUT FLOAT switch to FLOAT. Move the cable from the HIGH OUTPUT to the LOW OUTPUT. Short out the HIGH OUTPUT connector (inner conductor to outer conductor). The right display should show approximately 95%.
11. Remove the short from the HIGH OUTPUT, reconnect the HIGH INPUT to the HIGH OUTPUT, and set the OUTPUT switch to the ground position.
12. Move the cable from the HIGH INPUT to the LOW INPUT. Set the INPUT switch to FLOAT. The right display should show 100%.
13. Reconnect the HIGH OUTPUT to the HIGH INPUT and set the INPUT switch to the ground position. Press LOW PASS 80 kHz. Verify that the LOW PASS 80 kHz key light goes off.
14. Press the STOP FREQ key. While the key is pressed, the left display should show 20.000 kHz (the stop frequency setting at power up).
15. Press 100 kHz. The left display should show between 99.70 and 100.30 kHz.
16. Press SWEEP. During the sweep, the SWEEP key light should light. The source frequency sweeps, starting from approximately 20 Hz and stopping at approximately 100 kHz. The right display should show between 96 and 104% throughout the entire sweep.

Filter Check

17. Press the LOG/LIN key. The right display should read approximately 0.00 dB.
18. Press LOW PASS 80 kHz.
19. Use the numeric data and units keys to set frequency (but not the level) of the source (to approximately 80 kHz) until the right display reads -3 dB. The left display should show between 72 and 88 kHz.
20. Press LOW PASS 30 kHz. The 30 kHz key light should light. Adjust the frequency (but not the level) of the source (to approximately 30 kHz) until the right display reads -3 dB. The left display should show between 26 and 34 kHz.
21. Press LOW PASS 30 kHz again to turn it off.
22. If the instrument has Option 010 or 050 installed, press the 400 Hz HIGH PASS key. The 400 Hz HIGH-PASS key light should light. Adjust the frequency of the source (to approximately 400 Hz) until the right display reads -3 dB. The left display should show between 360 and 440 Hz.
23. Press the filter key listed in the following tables for the filter options installed in the instrument. The respective key light should light. For each filter, set the source frequency as shown in the table. Verify that the level ratio shown in the right display is within the limits shown for each frequency.

Table for CCITT Weighting Filter (Option 011 or 051)

Oscillator Frequency (Hz)	RATIO Limits (dB)
300	-12.1 to -9.1
800	-0.4 to +0.4
3 000	-7.1 to -4.1
3 500	-11.5 to -5.5
5 000	-40.0 to -32.0

Table for CCIR Weighting Filter (Option 012 or 052)

Oscillator Frequency (Hz)	RATIO Limits (dB)
31.5	-31.4 to -28.4
200	-14.5 to -13.1
6 300	+12.0 to +12.4
7 100	+11.7 to +12.3
10 000	+7.5 to +8.7
20 000	-23.7 to -20.7

Table for C-Message Weighting Filter (Option 013 or 053)

Oscillator Frequency (Hz)	RATIO Limits (dB)
100	-44.0 to -41.0
500	-9.0 to -6.0
1 000	-0.2 to +0.2
3 000	-4.0 to -1.0
5 000	-30.0 to -27.0

Table for CCIR/ARM Weighting Filter (Option 014 or 054)

Oscillator Frequency (Hz)	RATIO Limits (dB)
31.5	-37.0 to -34.0
200	-20.1 to -18.7
6 300	+6.4 to +6.8
7 100	+6.1 to +6.7
10 000	+1.9 to +3.1
20 000	-29.3 to -26.3

Table for "A" Weighting Filter (Option 015 or 055)

Oscillator Frequency (Hz)	RATIO Limits (dB)
50	-30.9 to -29.5
200	-11.7 to -10.3
1 000	-0.2 to +0.2
2 000	+0.5 to +1.9
10 000	-3.2 to -1.8
20 000	-10.8 to -7.8

Distortion Check

24. Set all filters on the Audio Analyzer off. Press LOW PASS 80 kHz. Press DISTN. The DISTN key light should light.
25. Set the source frequency to 1 kHz. The right display should show 0.01% or less.

SINAD Check

26. Press SINAD. The SINAD key light should light. The right display should show 80 dB or more.
27. Key in 6.1 SPCL to hold the notch filter. Set the source frequency to 890 Hz. The right display should show between 12 and 19 dB. The SINAD meter should read within ± 1 dB of the right display.

Signal-to-Noise Ratio Check

28. Press AUTOMATIC OPERATION. Press S (Shift) SIG/NOISE. The right display should show 85 dB or more.

Sweep, X Axis, Y Axis, Pen Lift, and DC Level Check

29. Disconnect the cable from the OUTPUT and reconnect it to the X AXIS connector on the rear panel.
30. Press S (Shift) DC LEVEL.
31. Press SWEEP. The right display should show a voltage rising from approximately 0 to 10V in uniform steps.
32. Move the cable from the X AXIS connector to the Y AXIS connector.
33. Press START FREQ. The right display should show between -0.01 and 0.01V.
34. Press STOP FREQ. The right display should show between 9.6 and 10.4V.
35. Disconnect the cable and reconnect it to the PEN LIFT connector.
36. Press SWEEP. The right display should momentarily show a TTL high level (greater than 2.4V), then drop to a TTL low level (less than 0.4V) and remain there until the sweep is complete. The display should then show a TTL high level.

3-6. HP-IB FUNCTIONAL CHECKS

Description

The following ten procedures check the Audio Analyzer's ability to process or send all of the applicable HP-IB messages described in Table 3-3. In addition, the Audio Analyzer's ability to recognize its HP-IB address is checked and all of the bus data, handshake, and control lines except DIO8 (the most significant data line which is not used by the Audio Analyzer) are set to both their true and false states. These procedures do not check whether or not all Audio Analyzer program codes are being properly interpreted and executed by the instrument, however, if the front-panel operation is good, the program codes, in all likelihood will be correctly implemented.

The validity of these checks is based on the following assumptions:

- The Audio Analyzer performs properly when operated via the front-panel keys (that is, in local mode). This can be verified with the Basic Functional Checks.
- The bus controller properly executes HP-IB operations.
- The bus controller's HP-IB interface properly executes the HP-IB operations.

If the Audio Analyzer appears to fail any of these HP-IB checks, the validity of the above assumptions should be confirmed before attempting to service the instrument.

The select code of the controller's HP-IB interface is assumed to be 7. The address of the Audio Analyzer is assumed to be 28 (its address as set at the factory). This select code-address combination (that is, 728) is not necessary for these checks to be valid. However, the program lines presented here would have to be modified for any other combination.

These checks are intended to be as independent of each other as possible. Nevertheless, the first four checks should be performed in order before other checks are selected. Any special initialization or requirements for a check are described at its beginning.

Initial Setup

The test setup is the same for all of the checks. Connect the Audio Analyzer to the bus controller via the HP-IB interface. Do not connect any equipment to the Audio Analyzer's INPUT.

Equipment

HP-IB Controller HP 9825A/98213A (General and Extended I/O ROM)
 -or- HP 85B Option 007
 -or- HP 9000 Model 226 or any HP 9000 series 200 Computer

Address Recognition

Description: This check determines whether or not the Audio Analyzer recognizes when it is being addressed and when it is not. This check assumes only that the Audio Analyzer can properly handshake on the bus. Before beginning this check, set the Audio Analyzer's LINE switch to OFF, then to ON.

Description	HPL	BASIC
Set the Remote Enable (REN) bus control line false. Send the Audio Analyzer's listen address.	lcl 7 wrt 728	LOCAL 7 OUTPUT 728

Check that the Audio Analyzer's REMOTE annunciator is off but its ADDRESSED annunciator is on.

Description	HPL	BASIC
Unaddress the Audio Analyzer by sending a different address.	wrt 729	OUTPUT 729

Check that both the Audio Analyzer's REMOTE and ADDRESSED annunciators are off.

Remote and Local Messages and the LCL Key

Description: This check determines whether the Audio Analyzer properly switches from local to remote control, from remote to local control, and whether the LCL key returns the instrument to local control. This check assumes that the Audio Analyzer is able to both handshake and recognize its own address. Before beginning this check, set the Audio Analyzer's LINE switch to OFF, then to ON.

Description	HPL	BASIC
Send the Remote message (by setting Remote Enable, REN, true and addressing the Audio Analyzer to listen).	rem728	REMOTE 728

Check that both the Audio Analyzer's REMOTE and ADDRESSED annunciators are on.

Send the Local message to the Audio Analyzer.	lcl 728	LOCAL
---	---------	-------

Check that the Audio Analyzer's REMOTE annunciator is off but its ADDRESSED annunciator is on.

Send the Remote message to the Audio Analyzer.	rem 728	REMOTE 728
--	---------	------------

Check that both the Audio Analyzer's REMOTE and ADDRESSED annunciators are on. Press the LCL key on the Audio Analyzer. Check that the Audio Analyzer's REMOTE annunciator is now off, but that its ADDRESSED annunciator remains on.

Sending the Data Message

Description: This check determines whether or not the Audio Analyzer properly issues Data messages when addressed to talk. This check assumes that the Audio Analyzer is able to handshake and recognize its own address. Before beginning this check, set the Audio Analyzer's LINE switch to OFF, then to ON, then after the power-up sequence is complete, press the DISTN key.

Description	HPL	BASIC
Address the Audio Analyzer to talk and store its output data in variable V. (The output is E96 since there is no signal at its INPUT.) Display the value of V.	red 728,V	ENTER 728;V
	dsp V	PRINT V

Check that the Audio Analyzer's REMOTE annunciator is off but that its ADDRESSED annunciator is on. The controller's display should read 9009600000.00 (HPL) or 9009600000 (BASIC).

Receiving the Data Message

Description: This check determines whether or not the Audio Analyzer properly receives Data messages. The Data messages sent also cause the 7 least significant HP-IB data lines to be placed in both their true and false states. This check assumes the Audio Analyzer is able to handshake, recognize its own address and properly make the remote/local transitions. Before beginning this check, set the Audio Analyzer's LINE switch to OFF, then to ON.

Description	HPL	BASIC
Send the first part of the Remote message (enabling the Audio Analyzer to remote). Address the Audio Analyzer to listen (completing the Remote message), then send a Data message (selecting the SINAD measurement).	rem 7 wrt 728,"M2"	REMOTE 7 OUTPUT 728;"M2"

Check that both the Audio Analyzer's REMOTE and ADDRESSED annunciators are on. Check also that its SINAD key light is on.

Local Lockout and Clear Lockout/Set Local Messages

Description: This check determines whether or not the Audio Analyzer properly receives the Local Lockout message, disabling all front-panel keys. The check also determines whether or not the Clear Lockout/Set Local message is properly received and executed by the Audio Analyzer. This check assumes that the Audio Analyzer is able to handshake, recognize its own address, and properly make the remote/local transitions. Before beginning this check, set the Audio Analyzer's LINE switch to OFF, then to ON.

Description	HPL	BASIC
Send the first part of the Remote message (enabling the Audio Analyzer to remote). Send the Local Lockout message. Address the Audio Analyzer to listen (completing the Remote message).	rem 7 llo 7 wrt 728	REMOTE 7 LOCAL LOCKOUT 7 OUTPUT 728

Check that both the Audio Analyzer's REMOTE and ADDRESSED annunciators are on. Press the Audio Analyzer's LCL key. Both its REMOTE and ADDRESSED annunciators should remain on.

Send the Clear Lockout/Set Local message.	lcl 7	LOCAL 7
---	-------	---------

Check that the Audio Analyzer's REMOTE annunciator is off but its ADDRESSED annunciator is on.

Clear Message

Description: This check determines whether or not the Audio Analyzer properly responds to the Clear message. This check assumes that the Audio Analyzer is able to handshake, recognize its own address, make the remote/local changes and receive Data messages. Before beginning this check set the Audio Analyzer's LINE switch to OFF, then to ON.

Description	HPL	BASIC
Send the first part of the Remote message (enabling the Audio Analyzer to remote). Address the Audio Analyzer to listen (completing the Remote message), then send a Data message that selects the SINAD measurement.	rem 7 wrt 728,"M2"	REMOTE 7 OUTPUT 728;"M2"

Check that both the Audio Analyzer's REMOTE and ADDRESSED annunciators are on and that the SINAD key light is also on.

Send the Clear message (setting the Audio Analyzer's measurement to AC LEVEL).	clr 728	RESET 728
--	---------	-----------

Check that both the Audio Analyzer's REMOTE and ADDRESSED annunciators are on and that the AC LEVEL key light is on.

Abort Message

Description: This check determines whether or not the Audio Analyzer becomes unaddressed when it receives the Abort message. This check assumes that the Audio Analyzer is able to handshake, recognize its own address, make the remote/local changes, and enter serial poll mode. Before beginning this check, set the Audio Analyzer's LINE switch to OFF, then to ON.

Description	HPL	BASIC
Send the Remote message to the Audio Analyzer.	rem 728	REMOTE 728

Check that both the Audio Analyzer's REMOTE and ADDRESSED annunciators are on.

Send the Abort message, unaddressing the Audio Analyzer to listen.	cli 7	ABORTIO 7
--	-------	-----------

Check that the Audio Analyzer's ADDRESSED annunciator is off. Note that the BASIC "ABORTIO" statement sends both the Abort message and the Local message. Thus if HPL is being used, the Audio Analyzer's REMOTE annunciator should remain on. If BASIC is being used, the Audio Analyzer's REMOTE annunciator should turn off.

Send the Local message Address the Audio Analyzer to talk and store its output data in variable V.	lcl 7 red 728,V	ABORTIO 7 (HPL only). (The Local message was already sent with the ABORTIO 7 statement above.) ENTER 728;V
---	------------------------	---

Check that the Audio Analyzer's REMOTE annunciator is off but its ADDRESSED annunciator is on.

Description	HPL	BASIC
Send the Abort message, unaddressing the Audio Analyzer to talk.	cli 7	ABORTIO 7

Check that both the Audio Analyzer's REMOTE and ADDRESSED annunciators are off.

Send the serial poll-enable bus command (SPE) through the interface to place the Audio Analyzer in serial poll mode.	wti 0,7; wti 6, 24	(Series 80 Controllers) SENBUS 728; 1, 24 (Series 200/300 Controllers) SEND 7; CMD 1, 24
--	--------------------	---

On the Audio Analyzer, key in 61.3 SPCL. The right display should show 1.0. This indicates the Audio Analyzer is in serial poll mode (indicated by the "1").

Send the Abort message, removing the Audio Analyzer from serial poll mode.	cli 7	ABORTIO 7
--	-------	-----------

Check that the Audio Analyzer's right display shows 0.0. This indicates the Audio Analyzer properly left serial-poll mode upon receiving the Abort message.

Status Byte Message

Description: This check determines whether or not the Audio Analyzer sends the Status Byte message in both the local and remote modes. This check assumes that the Audio Analyzer is able to handshake, recognize its own address, and make the remote/local changes. Before beginning this check, set the Audio Analyzer's LINE switch to OFF, then to ON.

Description	HPL	BASIC
Place the Audio analyzer in serial poll mode and address it to talk (causing it to send the Status Byte message).	rds (728)→V	(Series 80 Controllers) STATUS 728;V
Series 200/300 controllers: Define V with the program instruction: 10 V = 0 20 END. Display the Value of V.	rds (728)→V dsp V	(Series 200/300 Controllers) V = SPOLL (728) PRINT V

Check that Audio Analyzer's REMOTE annunciator is off. Depending upon the vintage of the HP-IB interface (HP HPL) used, the Audio Analyzer's ADDRESSED annunciator may be either on or off. The controller's display should read 0.00 (HPL) or 0 (BASIC).

Description	HPL	BASIC
Send the Remote message.	rem 728	REMOTE 728 (Series 80 Controllers)
Place the Audio Analyzer in serial poll mode and address it to talk (causing it to send the Status Byte message).	rds (728)→V	STATUS 728;V (Series 200/300 Controllers) V = SPOLL (728)
Display the value of V.	dsp V	PRINT V

Check that the Audio Analyzer's REMOTE annunciator is on. Depending upon the vintage of the HP-IB interface (HP HPL) used, the Audio Analyzer's ADDRESSED annunciator may be either on or off. The controller's display should read 0.00 (HPL) or 0 (BASIC).

Require Service Message

Description: This check determines whether or not the Audio Analyzer can issue the Require Service message (set the SRQ bus control line true). This check assumes that the Audio Analyzer is able to handshake, recognize its own address, make the remote/local changes, and receive Data messages. Before beginning this check, set the Audio Analyzer's LINE switch to OFF, then to ON, then after the power-up sequence is complete, press the DISTN key.

Description	HPL	BASIC
Send the first part of the Remote message (enabling the Audio Analyzer to remote).	rem 7	(Series 80 Controllers) REMOTE 7 (Series 200/300 Controllers) REMOTE 728
Address the Audio Analyzer to listen (completing the Remote message) then send a Data message (enabling a Require Service message to be sent upon Instrument Error).	wrt 728,"22.4SP"	OUTPUT 728;"22.4SP"
Make the controller wait 2 seconds to allow time for the Audio Analyzer to send the Require Service message. (This step is not necessary if sufficient time is allowed.)	wait 2000	WAIT 2000
Read the binary status of the controller's HP-IB interface and store the data in variable V (in this step, 7 is the interface's select code).	rds (7) →V	(Series 80 Controllers) STATUS 7; V (Series 200/300 Controllers) V = SPOLL (728)
Display the value of the SRQ bit (in this step, 6 is the SRQ bit, numbered from 0).	dsp"SRQ =",bit (6,V)	(Series 80 Controllers) PRINT "SRQ ="; BIT (V,7) (Series 200/300 Controllers) "PRINT/SRQ="BIT(V,6)

Check that the SRQ value is 1, indicating the Audio Analyzer issued the Require Service message.

Trigger Message and Clear Key Triggering

Description: This check determines whether or not the Audio Analyzer responds to the Trigger message and whether the CLEAR key serves as a manual trigger in remote. This check assumes that the Audio Analyzer is able to handshake, recognize its own address, make the remote/local changes, and send and receive Data messages. Before beginning this check, set the Audio Analyzer's LINE switch to OFF, then to ON, then, when the power-up sequence is complete, press the DISTN key.

Description	HPL	BASIC
Send the first part of the Remote message (enabling the Audio Analyzer to remote).	rem 7	(Series 80 Controllers) REMOTE 7 (Series 200/300 Controllers) REMOTE 728
Address the Audio Analyzer to listen (completing the Remote message), then send a Data message (placing the Audio Analyzer in Hold mode). Send the Trigger message.	wrt 728, "T1" trg 728	OUTPUT 728; "T1" TRIGGER 728
Address the Audio Analyzer to talk and store the data in variable V. Display the value of V.	red 728, V dsp V	ENTER 728; V PRINT V

Check that both the Audio Analyzer's REMOTE and ADDRESSED annunciators are on. The controller's display should read 9009600000.00 (HPL) or 9009600000 (BASIC).

Address the Audio Analyzer to talk and store the data in variable V.	red 728, V	ENTER 728;V
--	------------	-------------

Check that the controller's "run" indicator is still on indicating that it has not received data from the Audio Analyzer. Press the Audio Analyzer's CLEAR key. The controller's "run" indicator should turn off.

3-7. REMOTE OPERATION, HEWLETT-PACKARD INTERFACE BUS

The Audio Analyzer can be operated through the Hewlett-Packard Interface Bus (HP-IB). Bus compatibility, programming, and data formats are described in the following paragraphs.

Except for the LINE switch, the $\div 10$ and $\times 10$ keys, the low terminal ground/FLOAT switches, and the Controller Reset Service Special Function, all Audio Analyzer operations (including service-related functions) are fully programmable via HP-IB. In addition, rapid-source tuning and rapid-frequency count capabilities (not available from the front panel) are provided in remote operation.

A quick test of HP-IB is described under *HP-IB Functional Checks*. These checks verify that the Audio Analyzer can respond to or send each of the applicable bus messages described in Table 3-3.

For more information about HP-IB, refer to IEEE Standard 488, ANSI Standard MC1.1, the *Hewlett-Packard Electronic Systems and Instruments* catalog, and the booklet, "Tutorial Description of the Hewlett-Packard Interface Bus" (HP part number 5952-0156).

HP-IB Compatibility

The Audio Analyzer's complete bus compatibility (as defined by IEEE Standard 488, and the identical ANSI Standard MC1.1) is described at the end of Table 3-3. Table 3-3 also summarizes the Audio Analyzer's HP-IB capabilities in terms of the twelve bus messages in the left-hand column.

Remote Mode

Remote Capability. In remote, most of the Audio Analyzer's front-panel controls are disabled (exceptions are the LCL and CLEAR keys). However, front-panel displays and the signal at various outputs remain active and valid. In remote, the Audio Analyzer may be addressed to talk or listen. When addressed to listen, the Audio Analyzer will respond to the Data, Trigger, Clear (SDC), and Local messages. When addressed to talk, the Audio Analyzer can issue the Data and Status Byte messages. Whether addressed or not, the Audio Analyzer will respond to the Clear (DCL), Local Lockout, Clear Lockout/Set Local, and Abort messages, and in addition, the Audio Analyzer may issue the Require Service message.

Local-to-Remote Mode Changes. The Audio Analyzer switches to remote operation upon receipt of the Remote message. The Remote message has two parts. They are:

- Remote enable bus control line (REN) set true.
- Device listen address received once (while REN is true).

When the Audio Analyzer switches to remote, both the REMOTE and ADDRESSED annunciators on its front panel will turn on.

Local Mode

Local Capability. In local, the Audio Analyzer's front-panel controls are fully operational and the instrument will respond to the Remote message. Whether addressed or not, it will also respond to the Clear, Local Lockout, Clear Lockout/Set Local, and the Abort messages. When addressed to talk, the instrument can issue Data messages and the Status Byte message, and whether addressed or not, it can issue the Require Service message.

Remote-to-Local Mode Changes. The Audio Analyzer always switches to local from remote whenever it receives the Local message (GTL) or the Clear Lockout/Set Local message. (The Clear Lockout/Set Local message sets the Remote Enable control line [REN] false.) If it is not in Local Lockout mode, the Audio Analyzer switches to local from remote whenever its front panel LCL key is pressed.

Addressing

The Audio Analyzer interprets the byte on the bus' eight data lines as an address or a bus command if the bus is in the command mode: attention control line (ATN) true and interface clear control line (IFC) false. Whenever the Audio Analyzer is being addressed (whether in local or remote), the ADDRESSED annunciator on the front panel will turn on.

The Audio Analyzer talk and listen addresses are switch selectable as described in Section 2. Refer to Table 2-1 for a comprehensive listing of all valid HP-IB address codes. To determine the present address setting, refer to the discussion titled *HP-IB Address* in the *Detailed Operating Instructions* near the end of this section.

Table 3-3. Message Reference Table (1 of 2)

HP-IB Message	Applicable	Response	Related Commands and Controls	Interface Functions*
Data	Yes	All Audio Analyzer operations except the LINE switch, FLOAT switch, and the ÷10 and ×10 functions are bus-programmable. All measurement results, special displays, and error outputs except the " -- " display are available to the bus.		AH1 SH1 T5, TE0, L3, LE0
Trigger	Yes	If in remote and addressed to listen, the Audio Analyzer makes a settled measurement according to previously programmed setup. It responds equally to bus command GET and program code T3, Trigger with Settling (a Data message).	GET	DT1
Clear	Yes	Sets SOURCE to 1 kHz and 0 mV, MEASUREMENT to AC LEVEL with the 80 kHz LP FILTER on, and sets the trigger mode to free run. Resets many additional parameters as shown in Table 3-5. Clears Status Byte, RQS bit, Require Service message (if issued) and Local Lockout. Sets the Service Request Condition to the 22.2 state. Responds equally to Device Clear (DCL) and Selected Device Clear (SDC) bus commands.	DCL SDC	DC1
Remote	Yes	Remote mode is enabled when the REN bus control line is true. However, remote mode is not entered until the first time the Audio Analyzer is addressed to listen. The front-panel REMOTE annunciator lights when the instrument is actually in the remote mode. When entering remote mode, no instrument settings or functions are changed, but all front-panel keys except LCL and CLEAR are disabled, and entries in progress are cleared.	REN	RL1
Local	Yes	The Audio Analyzer returns to local mode (front-panel control). Responds equally to the GTL bus command and the front-panel LCL key. When entering local mode, no instrument settings or functions are changed but entries in progress are cleared. In local, triggering is free run only.	GTL	RL1
Local Lockout	Yes	Disables all front-panel keys including LCL and CLEAR. Only the controller can return the Audio Analyzer to local (front-panel control).	LLO	RL1
Clear Lockout/ Set Local	Yes	The Audio Analyzer returns to local (front-panel control) and local lockout is cleared when the REN bus control line goes false. When entering local mode, no instrument settings or functions are changed, but entries in progress are cleared. In local, triggering is free run only.	REN	RL1
Pass Control/ Take Control	No	The Audio Analyzer has no control capability.		C0

* Commands, Control lines, and Interface Functions are defined in IEEE Std. 488. Knowledge of these might not be necessary if your controller's manual describes programming in terms of the twelve HP-IB Messages shown in the left column.

Table 3-3. Message Reference Table (2 of 2)

HP-IB Message	Applicable	Response	Related Commands and Controls	Interface Functions*
Require Service	Yes	The Audio Analyzer sets the SRQ bus control line true if an invalid program code is received. The Audio Analyzer will also set SRQ true, if enabled by the operator to do so, when measurement data is ready or when an instrument error occurs.	SRQ	SR1
Status Byte	Yes	The Audio Analyzer responds to a Serial Poll Enable (SPE) bus command by sending an 8-bit byte when addressed to talk. If the instrument is holding the SRQ control line true (issuing the Require Service message) bit 7 (RQS bit) in the Status Byte and the bit representing the condition causing the Require Service message to be issued will both be true. The bits in the Status Byte are latched but can be cleared by: 1) removing the causing condition, and 2) reading the Status Byte.	SPE SPD	T5, TE0
Status Bit	No	The Audio Analyzer does not respond to a parallel poll.		PPO
Abort	Yes	The Audio Analyzer stops talking and listening.	IFC	T5, TE0, L3, LE0
* Commands, Control lines, and Interface Functions are defined in IEEE Std. 488. Knowledge of these might not be necessary if your controller's manual describes programming in terms of the twelve HP-IB Messages shown in the left column.				

Complete HP-IB capability as defined in IEEE Std. 488 and ANSI Std. MC1.1 is: SH1, AH1, T5, TE0, L3, LE0, SR1, RL1, PP0, DC1, DT1, C0, E1.

Local Lockout. When a data transmission is interrupted, which can happen by returning the Audio Analyzer to local mode by pressing the LCL key, the data could be lost. This would leave the Audio Analyzer in an unknown state. To prevent this, a local lockout is recommended. Local lockout disables the LCL key (and the CLEAR key) and allows return-to-local only under program control.

NOTE

Return-to-local can also be accomplished by turning the Audio Analyzer's LINE switch to OFF, then back to ON. However, this technique has several disadvantages:

- *It defeats the purpose and advantages of local lockout (that is, the system controller will lose control of a system element).*
- *There are several HP-IB conditions that reset to default states at turn-on.*

Data Messages

The Audio Analyzer communicates on the interface bus primarily with data messages. Data messages consist of one or more bytes sent over the 8 data bus lines, when the bus is in the data mode (attention control line [ATN] false). Unless it is set to Talk Only, the Audio Analyzer receives data messages when addressed to listen. Unless it is set to Listen Only, the Audio Analyzer sends data messages or the Status Byte message (if enabled) when addressed to talk. Virtually all instrument operations available in local mode may be performed in remote mode via data messages. The only exceptions are changing the LINE switch, FLOAT switches, the $\div 10$ or $\times 10$ keys, and the Controller Reset Service Special Function. In addition, the Audio Analyzer may be triggered via data messages to make measurements at a particular time.

Receiving the Data Message

Depending on how the internal address switches are set, the Audio Analyzer can either talk only, talk status only, listen only, or talk and listen both (normal operation). The instrument responds to Data messages when it is enabled to remote (REN control line true) and it is addressed to listen or set to Listen Only. If not set to Listen Only, the instrument remains addressed to listen until it receives an Abort message or until its talk address or a universal unlisten command is sent by the controller.

Listen Only. If the internal LON (Listen Only) switch is set to "1", the Audio Analyzer is placed in the Listen Only mode when the remote enable bus control line (REN) is set true. The instrument then responds to all Data messages, and the Trigger, Clear, and Local Lockout messages. However, it is inhibited from responding to the Local or Abort messages and from responding to a serial poll with the Status Byte message.

Listen Only mode is provided to allow the Audio Analyzer to accept programming from devices other than controllers (for example, card readers).

Data Input Format. The Data message string, or program string, consists of a series of ASCII codes. With the exception of the Rapid Source mode, each code is typically equivalent to a front-panel keystroke in local mode. Thus, for a given operation, the program string syntax in remote mode is the same as the keystroke sequence in local mode. (For information about RS, Rapid Source, refer to *Rapid Source* in the *Detailed Operating Instructions*.) Example 1 shows the general-case programming order for selecting Audio Analyzer functions. Specific program order considerations are discussed in the following paragraphs under "Program Order Considerations." All functions can be programmed together as a continuous string as typified in Example 2. The string in Example 2 clears most Special Functions (with Automatic Operation), programs the source to 440 Hz at 1V, selects a distortion measurement with 30 kHz low-pass filtering and log units, then triggers a settled measurement.

Program Codes. Most all of the valid HP-IB codes for controlling Audio Analyzer functions are summarized in Table 3-6. All front-panel keys except the LCL key and the $\div 10$ and $\times 10$ keys have corresponding program codes (exception: Service Special Functions).

Table 3-4 shows the Audio Analyzer's response to various ASCII characters not used in its code set. The characters in the top column will be ignored unless they appear between two characters of a program code. The characters in the bottom column, if received by the Audio Analyzer, will always cause Error 24 (invalid HP-IB code) to be displayed and a Require Service message to be generated. The controller recognizes the invalid code entry and clears the Require Service condition. Thereafter, the invalid code entry is ignored, and subsequent valid entries are processed in normal fashion. As a convenience, all lower case alpha characters are treated as upper case.

Table 3-4. Audio Analyzer Response to Unused ASCII Codes

Ignored†				
!	#	(,	
"	%)	/	
"	&	*		
Generate Error 24				
@	I	Z	^	}
B	J	[~	~
E	Q	\		DEL
G	Y]		

†Except when inserted between two characters of a program code.

EXAMPLE 1: General Program Syntax and Protocol*

{ Controller Talk
Audio Analyzer Listen }

[Automatic Operation][Source Frequency][Source Amplitude][Measurement][Filters][Special Functions][Log/Lin][Ratio][Start Frequency]...
...[Stop Frequency][Plot Limit][Sweep][Trigger]

*Excluding Rapid Source or Rapid Frequency Count Modes.

EXAMPLE 2: Typical Program String

{ Controller Talk
Audio Analyzer Listen }

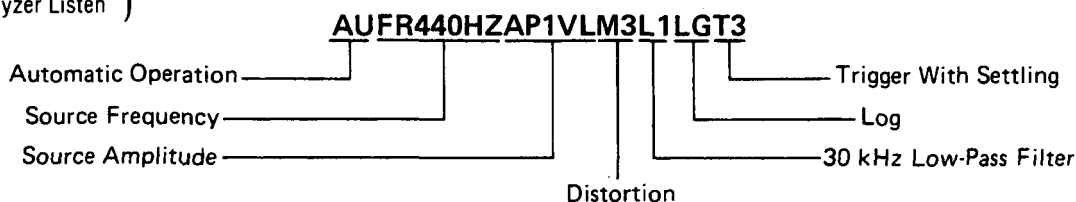

Turning off Functions. When operating in local mode, the High-Pass/Bandpass (optional plug-in filters), and Low-Pass Filters, and Ratio functions toggle on and off with successive keystrokes. In remote mode, these functions do not toggle on and off. Instead, each of the above groups has a specific code which turns off all the keys in the group. The HP-IB codes for turning off these functions are given in the following table.

Function	HP-IB Code
HP/BP FILTERS all off	H0
LP FILTERS all off	L0
RATIO off	R0
SWEEP off	W0

Programming Numeric Data. When programming source amplitude or frequency, entering ratio references, plot limits, or issuing any numeric data (other than specific HP-IB codes) to the Audio Analyzer, certain precautions should be observed. Numeric data may be entered in fixed, floating

point, or exponential formats. Usually, numeric data consists of a signed mantissa of up to five digits (including leading zeros), one decimal point, and one- or two-digit signed exponent. The decimal point may fall between any two digits of the mantissa but should not appear ahead of the first digit. If it does, a leading zero will be automatically inserted by the Audio Analyzer. Any digit beyond the five allowed for the mantissa will be received as zero. The general format for numeric data entry is given below, followed by several examples illustrating various entries and the resulting data as received by the Audio Analyzer.

General Numeric Data Input Format:

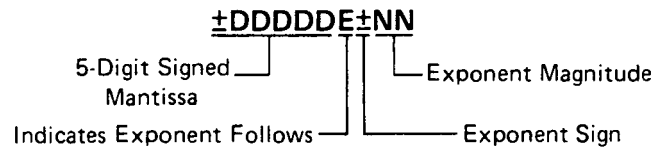

Example: +.12345E+01 issued
0.12340E+01 received by
Audio Analyzer

Example: +123456E+01 issued
123450E+01 received by
Audio Analyzer

Example: +00012345 issued
12000 received by
Audio Analyzer

In general, do not issue numeric data with more significant digits than can be displayed on the Audio Analyzer's left five-digit display.

NOTE

The above numeric data input format information does not apply to the Rapid Source mode. Refer to Rapid Source in the Detailed Operating Instructions.

Triggering Measurements with the Data Message. A feature that is only available via remote programming is the selection of free run, standby, or triggered operation of the Audio Analyzer. During local operation, the Audio Analyzer is allowed to free run outputting data to the display as each measurement is completed. In remote (except in sweep), three additional operating modes are allowed: Hold, Trigger Immediate, and Trigger with Settling. In addition, the CLEAR key can act as a manual trigger while the instrument is in remote. The trigger modes and use of the Clear key are described below.

Free Run (T0). This mode is identical to local operation and is the mode of operation in effect when no other trigger mode has been selected. The measurement result data available to the bus are constantly being updated as rapidly as the Audio Analyzer can make measurements. A Device Clear message or entry into remote from local sets the Audio Analyzer to the Free Run mode.

NOTE

Free Run triggering (code T0) is the only trigger mode allowed when using the sweep function (code W1). Any other triggering (codes T1, T2, or T3) or use of CLEAR key triggering will cause only the start frequency point to be displayed, plotted, and read to the HP-IB. Both the rear-panel X AXIS and Y AXIS outputs will be inhibited from continuing beyond the start frequency point.

Hold (T1). This mode is used to set up triggered measurements (initiated by program codes T2 or T3, the Trigger message, or the CLEAR key). In Hold mode, internal settings can be altered by the instrument itself or by the user via the bus. Thus, the signal at the MONITOR output *can change*. However, the instrument is inhibited from outputting any data to the front-panel key lights and display, to the rear-panel X AXIS or Y AXIS outputs, or to the HP-IB except as follows. The instrument will issue the Require Service message if an HP-IB code error occurs. The instrument will issue the Status Byte message if serial polled. (A serial poll, however, will trigger a new measurement, update displays and return the instrument to Hold.)

Upon leaving Hold, the front-panel indications are updated as the new measurement cycle begins. The Status Byte will be affected (and the Require Service message issued) by the events that occur during the new measurement cycle. The Audio Analyzer leaves Hold when it receives either the Free Run, Trigger Immediate, Trigger with Settling codes, or the Trigger Message, when the CLEAR key is pressed (if not in Local Lockout), or when it returns to local operation.

Trigger Immediate (T2). When the Audio Analyzer receives the Trigger Immediate code, it makes one measurement in the shortest possible time. The instrument then waits for the measurement results to be read. While waiting, the instrument can process most bus commands without losing the measurement results. However, if the instrument receives GTL (Go To Local), GET (Group Execute Trigger), its listen address, or if it is triggered by the CLEAR key, a new measurement cycle will be executed. Once the data (measurement results) are read onto the bus, the Audio Analyzer reverts to the Hold mode. Measurement results obtained via Trigger Immediate are normally valid only when the instrument is in a steady, settled state.

Trigger with Settling (T3). Trigger with Settling is identical to Trigger Immediate except the Audio Analyzer inserts a settling-time delay before taking the requested measurement. This settling time is sufficient to produce valid, accurate measurement results. Trigger with Settling is the trigger type executed when a Trigger message is received via the bus.

Triggering Measurements with the CLEAR Key. When the Audio Analyzer is in remote Hold mode and not in Local Lockout, the front-panel CLEAR key may be used to issue a Trigger with Settling instruction. Place the instrument in Hold mode (code T1). Each time the CLEAR key is pressed, the Audio Analyzer performs one Trigger with Settling measurement cycle, then waits for the data to be read. Once the data is read out to the bus, the instrument returns to Hold mode. If data is not read between trigger cycles, it will be replaced with data acquired from subsequent measurements.

Special Considerations for Triggered Operation. When in free-run mode, the Audio Analyzer must pay attention to all universal bus commands, for example, “serial poll enable (SPE)”, “local lockout (LLO)”, etc. In addition, if it is addressed to listen, it must pay attention to all addressed bus commands, such as, “go to local (GTL)”, “group execute trigger (GET)”, etc. As a consequence of this, the Audio Analyzer must interrupt the current measurement cycle to determine whether any action in response to these commands is necessary. Since many elements of the measurements are transitory, the measurement must be reinitiated following each interruption. Thus, if much bus activity occurs while the Audio Analyzer is trying to take a measurement, that measurement may never be completed.

Trigger Immediate and Trigger with Settling provide a way to avoid this problem. When the Trigger Immediate (T2) and Trigger with Settling (T3) codes are received, the Audio Analyzer will not allow its measurement to be interrupted; **indeed, even handshake of bus commands are inhibited until the measurement is complete.** Once the measurement is complete, bus commands will be processed, as discussed under Trigger Immediate above, with no loss of data. Thus, in an HP-IB environment where many bus commands are present, Trigger Immediate or Trigger with Settling should be used for failsafe operation.

NOTE

Free Run triggering (code T0) is the only trigger mode allowed when using the sweep function (code W1). Any other triggering (codes T1, T2, or T3) or use of CLEAR key triggering will cause only the start frequency point to be displayed, plotted, and read to the HP-IB. Both the rear-panel X AXIS and Y AXIS outputs will be inhibited from continuing beyond the start frequency point.

Reading Data from the Right or Left Display. The Audio Analyzer can only read data to the HP-IB once for each measurement made. Only the information on one display can be read each time. Use the codes RR (read right display) or RL (read left display) to control which information is read. The display will remain selected until the opposing display is specified (or until a clear message is received or power-up occurs). Errors (which occupy two displays) are output as described above, and DC LEVEL measurement results (always occupying the right display only) are placed on the bus (when requested) regardless of which display is enabled.

Program Order Considerations. Although program string syntax is virtually identical to keystroke order, some program order considerations need highlighting.

Automatic Operation (AU). As in local mode, when AUTOMATIC OPERATION is executed in remote it sets all Special Functions prefixed 1 through 8 to their zero-suffix mode, and also affects many other Special Functions. Thus when AUTOMATIC OPERATION is used, it should appear at the beginning of a program string.

Frequency or Amplitude Increment Step Up or Step Down (UP or DN). When a Step Up (UP) or Step Down (DN) is executed, the frequency or the amplitude is modified as determined by the established increment. The parameter changed is dependent upon which increment command was executed last. To insure the correct modification, program either Frequency Increment (FN) or Amplitude Increment (AN) immediately before the UP or DN command.

Trigger Immediate and Trigger with Settling (T2 and T3). When either of the trigger codes T2 or T3 is received by the Audio Analyzer, a measurement is immediately initiated. Once the measurement is complete, some bus commands can be processed without losing the measurement results. However, any HP-IB program code sent to the Audio Analyzer before the triggered measurement results have been output will initiate a new measurement. Thus, trigger codes should always appear at the end of a program string, and the triggered measurement results must be read before any additional program codes are sent.

Sending the Data Message

Depending on how the internal address switches are set, the Audio Analyzer can either talk only, talk status only, listen only, or talk and listen both (normal operation). If set to both talk and listen, the instrument sends Data messages when addressed to talk. The instrument then remains configured to talk until it is unaddressed to talk by the controller. To unaddress the Audio Analyzer, the controller must send either an Abort message, a new talk address, or a universal untalk command.

Talk Only Mode. If the internal address switches are set to a valid Talk address and the TON (Talk Only) switch is set to "1", the Audio Analyzer is placed in the Talk Only mode. In this mode instrument is configured to send Data messages whenever the bus is in the data mode. Each time the measurement is completed, the measurement result will be output to the bus unless the listening device is not ready for data. If the listener is not ready and the Audio Analyzer is not in a trigger mode, another measurement cycle is executed.

Talk Status Only Mode. If all the internal address switches and the TON (Talk Only) switch are set to "1", but the LON (Listen Only) switch is set to "0", the Audio Analyzer is placed in the Talk Status Only mode. In this mode the instrument is configured to send a one-byte data message whenever the bus is in the data mode. The byte sent is an exact copy of the Status Byte. Each time this byte is successfully sent on the bus, the internal Status Byte is cleared. The Data Valid (DAV) handshake line is pulsed each time the one-byte Data message is sent.

Data Output Format. As shown below, the output data is usually formatted as a real constant in exponential form: first the sign, then five digits (leading zeros not suppressed) followed by the letter E and a signed power-of-ten multiplier. (Refer to *Rapid Frequency Count* in the *Detailed Operation Instructions* for the only exceptions to this format.) The string is terminated by a carriage return (CR) and a line feed (LF), string positions 11 and 12. Data is always output in fundamental units (for example, Hz, volts, dB, %, etc.), and the decimal point (not sent) is assumed to be to the right of the fifth digit of the mantissa. Data values never exceed 4 000 000 000.

Data Output Format:

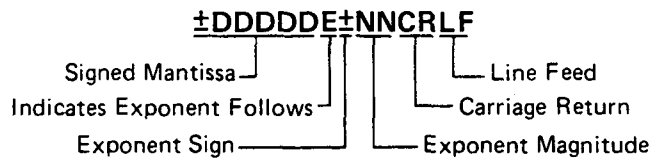

NOTE

For the only exception to the above format, refer to Rapid Frequency Count in the Detailed Operating Instructions.

When an error is output to the bus, it follows the same twelve-byte format described above except most of the numeric digits have predetermined values as shown below. Error outputs always exceed 9 000 000 000. The two-digit error code is represented by the last two digits of the five-digit mantissa. The error code can be derived from the string by subtracting 9×10^9 , then dividing the results by 100 000.

Error Output Format:

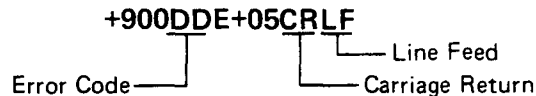

Receiving the Clear Message

The Audio Analyzer responds to the Clear message by assuming the settings detailed in Table 3-5. The Audio Analyzer responds equally to the Selected Device Clear (SDC) bus command when addressed to listen, and the Device Clear (DCL) bus command whether addressed or not. The Clear message clears any pending Require Service message and resets the Service Request Condition (Special Function 22) such that the Require Service message will be issued on HP-IB code errors only (22.2 SPCL).

Receiving the Trigger Message

When in remote and addressed to listen, the Audio Analyzer responds to a Trigger message by executing one settled-measurement cycle. The Audio Analyzer responds equally to a Trigger message (the Group Execute Trigger bus command [GET]) and a Data message, program code T3 (Trigger with Settling).

Refer to the paragraph "Triggering Measurements with the Data Message" under *Receiving the Data Message*.

Receiving the Remote Message

The Remote message has two parts. First, the remote enable bus control line (REN) is held true, then the device listen address is sent by the controller. These two actions combine to place the Audio Analyzer in remote mode. Thus, the Audio Analyzer is enabled to go into remote when the controller begins the Remote message, but it does not actually switch to remote until addressed to listen the first time. No instrument settings are changed by the transition from local to remote, but the Trigger mode is set to Free Run (code T0). When actually in remote, the Audio Analyzer lights its front-panel REMOTE annunciator. When the Audio Analyzer is being addressed (whether in remote or local), its front-panel ADDRESSED annunciator turns on.

Table 3-5. Response to a Clear Message

Parameter	Setting
Start Frequency	20 Hz
Stop Frequency	20 kHz
Plot Limits	
Lower	-100.0
Upper	+100.0
X-Y Recorder	Enabled
Frequency	1000.0 Hz
Frequency Increment	1000.0 Hz
Amplitude	0.00 mV
Amplitude Increment	0.100V
Measurement	AC Level
Detection	RMS
Low-Pass (LP) Filter	80 kHz Low-Pass On
High-Pass (HP)/ Bandpass (BP) Filter	All off
SPCL	All Special Functions off or set to their zero-suffix mode except Service Request Condition set to 22.2 (HP-IB code error).
Ratio	Off
Log/Lin	Linear (refer to RATIO and LOG/LIN Detailed Operating Instructions.)
Right Display Read	Enabled
Service Request Condition	HP-IB Code Error Only
Status Byte	Cleared
Trigger Mode	Free Run (Code T0)
Local Lockout	Cleared

Receiving the Local Message

The Local message is the means by which the controller sends the Go To Local (GTL) bus command. If addressed to listen, the Audio Analyzer returns to front-panel control when it receives the Local message. If the instrument was in local lockout when the Local message was received, front-panel control is returned, but lockout is not cleared. Unless it receives the Clear Lockout/Set Local message, the Audio Analyzer will return to local lockout the next time it goes to remote. No instrument settings are changed by the transition from remote to local, but all measurements are made in a free run mode.

When the Audio Analyzer goes to local mode, the front-panel REMOTE annunciator turns off. However, when the Audio Analyzer is being addressed (whether in remote or local), its front-panel ADDRESSED annunciator lights.

If the Audio Analyzer is not in local lockout mode, pressing the front-panel LCL (local) key might interrupt a Data message being sent to the instrument, leaving the instrument in a state unknown to the controller. This can be prevented by disabling the Audio Analyzer's front-panel keys entirely using the Local Lockout message.

Receiving the Local Lockout Message

The Local Lockout message is the means by which the controller sends the Local Lockout (LLO) bus command. If in remote, the Audio Analyzer responds to the Local Lockout Message by disabling the front-panel LCL (local) and CLEAR keys. (In remote, CLEAR initiates a Trigger with Settling cycle.) The local lockout mode prevents loss of data or system control due to someone accidentally pressing front-panel keys. If, while in local, the Audio Analyzer is enabled to remote (that is, REN is set true) and it receives the Local Lockout Message, it will switch to remote mode with local lockout the first time it is addressed to listen. When in local lockout, the Audio Analyzer can be returned to local only by the controller (using the Local or Clear Lockout/Set Local messages), by setting the LINE switch to OFF and back to ON, or by removing the bus cable.

Receiving the Clear Lockout/Set Local Message

The Clear Lockout/Set Local message is the means by which the controller sets the Remote Enable (REN) bus control line false. The Audio Analyzer returns to local mode (full front-panel control) when it receives the Clear Lockout/Set Local message. No instrument settings are changed by the transition from remote with local lockout to local. When the Audio Analyzer goes to local mode, the front-panel REMOTE annunciator turns off.

Receiving the Pass Control Message

The Audio Analyzer does not respond to the Pass Control message because it cannot act as a controller.

Sending the Require Service Message

The Audio Analyzer sends the Require Service message by setting the Service Request (SRQ) bus control line true. The instrument can send the Require Service message in either local or remote mode. The Require Service message is cleared when a serial poll is executed by the controller or if a Clear message is received by the Audio Analyzer. (During serial poll, the Require Service message is cleared immediately before the Audio Analyzer places the Status Byte message on the bus.) An HP-IB code error will always cause a Require Service message to be issued. In addition, there are two other conditions which can be enabled to cause the Require Service message to be sent when they occur. All three conditions are described below:

- Data Ready: When the Audio Analyzer is ready to send any information except error codes or the Status Byte.
- HP-IB Code Error: When the Audio Analyzer receives an invalid Data message. (This condition always causes a Require Service message to be sent.)

NOTE

The “- - -” display indicates a transient condition. After nine attempts to make a measurement, it is replaced by Error 31 which causes the Require Service message to be sent.

- Instrument Error: When any Error is being displayed by the Audio Analyzer, including the HP-IB Code error (Error 24).

Selecting the Service Request Condition

Use Special Function 22, Service Request Condition, to enable the Audio Analyzer to issue the Require Service message on any of the above conditions (except HP-IB code errors which always cause the Require Service message to be sent). The Service Request Condition Special Function is entered from either the front panel or via the HP-IB. The conditions enabled by Special Function 22 are always disabled by the Clear message. A description of the Service Request Condition Special Function and the procedure for enabling the various conditions are given under *Service Request Condition* in the *Detailed Operation Instructions*. Normally, device subroutines for the Audio Analyzer can be implemented simply by triggering measurements then reading the output data. In certain applications, the controller must perform other tasks while controlling the Audio Analyzer. Figure 3-7 illustrates a flow chart for developing device subroutines using the instrument's ability to issue the Require Service message when data is ready. This subroutine structure frees the controller to process other routines until the Audio Analyzer is ready with data.

Sending the Status Byte Message

The Status Byte message consists of one 8-bit byte in which 3 of the bits are set according to the enabled conditions described above under *Sending the Require Service Message*. If one or more of the three conditions previously described are both enabled and present, all the bits corresponding to the conditions (and also bit 7 the RQS bit) will be set true, and the Require Service message is sent. If one of the above conditions occurs but has not been enabled by Special Function 22, neither the bit corresponding to the condition nor the RQS bit will be set (and the Require Service message will not be sent). The bit pattern of the Status Byte is shown in the table labeled "STATUS Byte;" under paragraph 3-7, *HP-IB Syntax and Characteristics Summary* on the following pages.

Once the Audio Analyzer receives the serial poll enable bus command (SPE), it is no longer allowed to alter the Status Byte. When addressed to talk (following SPE), the Audio Analyzer sends the Status Byte message.

NOTE

Since the Audio Analyzer cannot alter the Status Byte while in serial poll mode, it is not possible to continually request the Status Byte while waiting for a condition to cause a bit to be set.

After the Status Byte message has been sent it will be cleared if the Serial Poll Disable (SPD) bus command is received, if the Abort message is received, or if the Audio Analyzer is unaddressed to talk. Regardless of whether or not the Status Byte message has been sent, the Status Byte and any Require Service message pending will be cleared if a Clear message is received. If the instrument is set to Talk Only, the Status Byte is cleared each time the one-byte Data message is issued to the bus.

Sending the Status Bit Message

The Audio Analyzer does not respond to a Parallel Poll Enable (PPE) bus command and thus cannot send the Status Bit Message.

Receiving the Abort Message

The Abort Message is the means by which the controller sets the Interface Clear (IFC) bus control line true. When the Abort message is received, the Audio Analyzer becomes unaddressed and stops talking or listening.

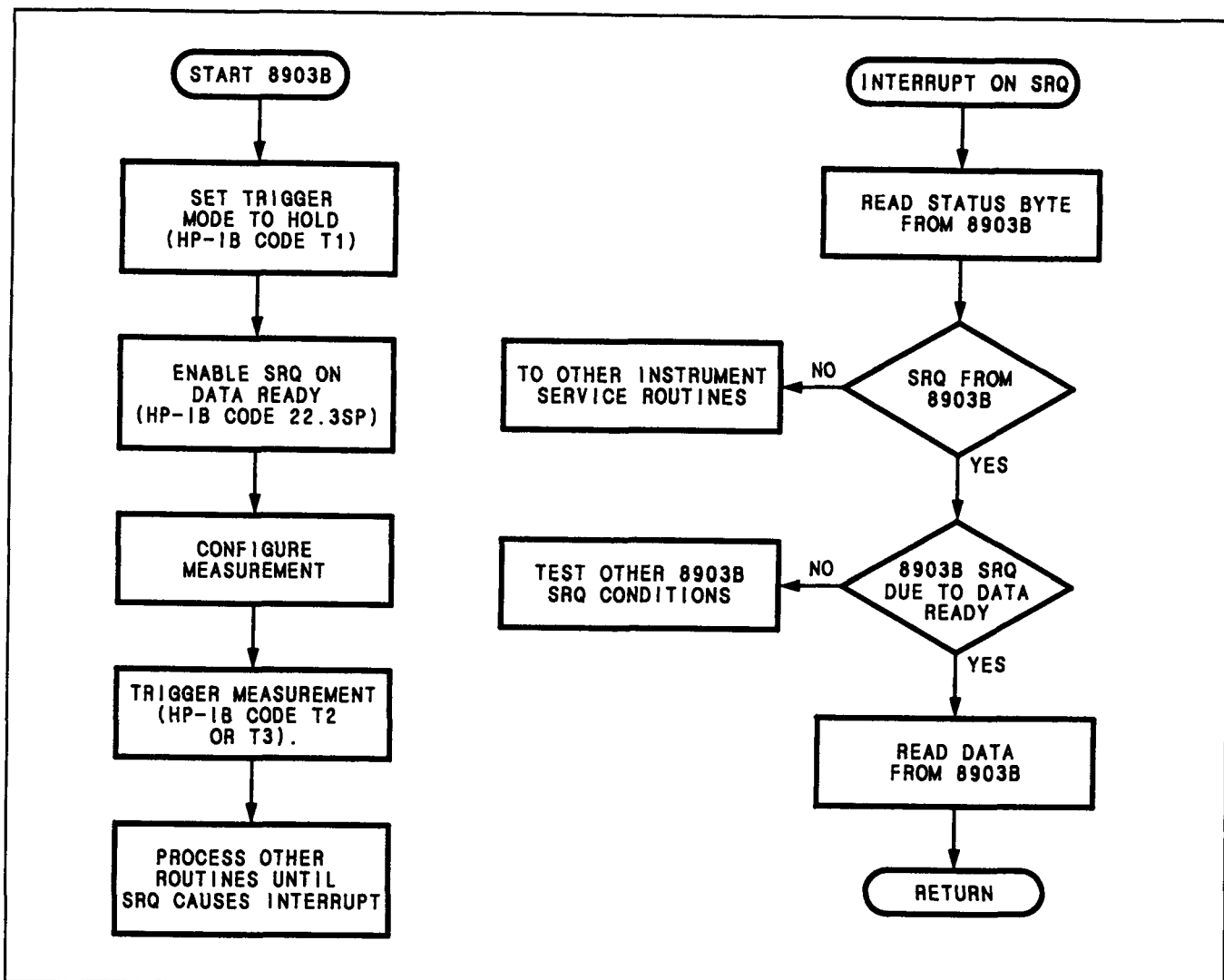

Figure 3-4. Example Flow Chart for Driving the Audio Analyzer Using the Require Service Message (SRQ)

3-7. HP-IB SYNTAX AND CHARACTERISTICS SUMMARY

Address: Set in binary by internal switches — may be displayed on front panel using Special Function 21, HP-IB Address. (Factory set to 28 decimal; 11100 binary.)

General Operating Syntax: (Excluding Rapid Frequency Count and Rapid Source modes.)* [Automatic Operation] [Source Frequency] [Source Amplitude] [Measurement] [Filters] [Special Functions] [Log/Lin] [Ratio] ... [Start Frequency] [Stop Frequency] [Plot Limit] [Sweep] [Trigger]

Numeric Data Input Format: (Except in Rapid Source mode.)*

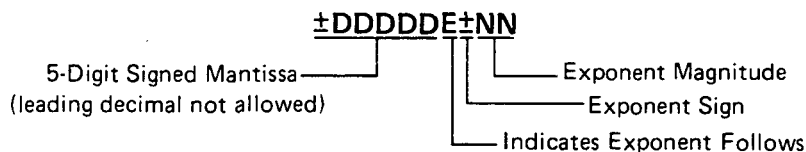

*For information on Rapid Frequency Count or Rapid Source modes refer to them by name in the Detailed Operating Instructions.

Output Formats: (Except in Rapid Frequency Count mode.)* Data (valid data output value always $<9 \times 10^9$ and in fundamental units):

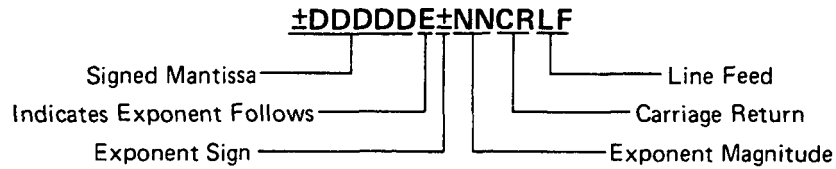

Errors:

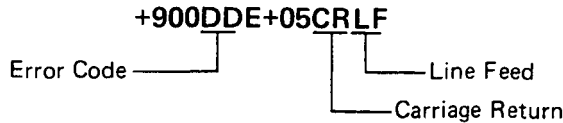

Return to Local:

Front panel LCL key if not locked out.

Manual Trigger:

Front panel CLEAR key initiates Trigger with Settling measurement.

Status Byte:

Bit	8	7	6	5	4	3	2	1
Weight	128	64	32	16	8	4	2	1
Service Request Condition	0 (always)	RQS Bit Require Service	0 (always)	0 (always)	0 (always)	Instru-ment Error	HP-IB Code Error	Data Ready

Notes: 1. The condition indicated in bits 1 and 3 must be enabled to cause a Service Request by Special Function 22, Service Request Condition.
 2. The RQS bit (bit 7) is set true whenever an HP-IB code error occurs or when any of the conditions of bits 1 and 3 are enabled and occur.
 3. Bits set remain set until the Status Byte is cleared.

Complete HP-IB Capability (as described in IEEE Std 488, and ANSI Std MC1.1): SH1, AH1, T5, TE0, L3, LE0, SR1, RL1, PP0, DC1, DT1, C0, E1.

*For information on Rapid Frequency Count or Rapid Source modes refer to them by name in the Detailed Operating Instructions.

Table 3-6. Audio Analyzer Parameter to HP-IB Code Summary

Parameter	Program Code	Parameter	Program Code
Source		Internal Plug-in HP/BP Filters	
Function		Left Plug-in Filter on	H1
Start Frequency	FA	Right Plug-in Filter on	H2
Stop Frequency	FB	All Plug-in HP/BP Filters off	H0
Plot Limit	PL		
Frequency Increment	FN	LP Filters	
Amplitude	AP	30 kHz LP Filter on	L1
Amplitude Increment	AN	80 Khz LP Filter on	L2
		All LP Filters off	L0
Data		Ratio	
- (minus)	-	On	R1
Clear*	CL	Off	R0
0-9	0-9		
.(decimal point)	.	Log/Lin	
Units		Log	LG
kHz	KZ	Lin	LN
V	VL		
Upper Limit	UL	Trigger Modes	
Hz	HZ	Free Run	T0
mV	MV	Hold	T1
Lower Limit	LL	Trigger Immediate	T2
dB	DB	Trigger with Settling	T3
dBm into 600Ω (dBre.775V)	DV		
Sweep on	W1	Miscellaneous	
Sweep off	W0	Read Left Display	RL
↑ (step up)	UP	Read Right Display	RR
↓ (step down)	DN	Rapid Frequency Count	RF
		Rapid Source	RS
Automatic Operation	AU		
SPCL	SP		
SPCL SPCL	SS		
Measurements			
AC Level	M1		
SINAD	M2		
Distortion	M3		
DC Level	S1		
Signal-to-Noise	S2		
Distortion Level	S3		
RMS Detector	A0		
AVG Detector	A1		
Automatic Notch Tuning	N0		
Notch Hold	N1		

* Not to be confused with Clear message which is defined in Table 3-3.

Table 3-7. Audio Analyzer HP-IB Code to Parameter Summary

Program Code	Parameter	Program Code	Parameter
A0	RMS Detector	N0	Automatic Notch Tuning
A1	AVG Detector	N1	Notch Hold
AN	Amplitude Increment		
AP	Amplitude	PL	
AU	Automatic Operation		
*CL	Clear	RF	Rapid Frequency Count
DV	dBm into 600Ω (dBre.775V)	RL	Read Left Display
DB	dB	RR	Read Right Display
DN	↓ (stepdown)	RS	Rapid Source
FA	Start Frequency	R1	Ratio On
FB	Stop Frequency	R0	Ratio Off
FN	Frequency Increment	SP	SPCL
FR	Frequency	SS	SPCL SPCL
		S1	DCLevel
		S2	Signal-to-Noise
		S3	Distortion Level
HZ	Hz		
H0	All Internal Plug-in HP/BP Filters off	T0	Free Run
H1	Left Plug-in Filter on	T1	Hold
H2	Right Plug-in Filter on	T2	Trigger immediate
		T3	Trigger with Setting
KZ	kHz		
		UP	↑(step-up)
		UL	Upper Limit
LG	Log		
LN	Linear		
LL	Lower Limit	VL	V
L0	All LP Filters off		
L1	30 kHz LP Filter on	W0	Sweep off
L2	80 kHz LP Filter on	W1	Sweep on
MV	mV	-	-(minus)
M1	AC Level	0-9	0-9
M2	SINAD	.	.(decimal point)
M3	Distortion		

3-8. Audio Analyzer Special Function to HP-IB Code Summary (1 of 2)

Special Function	Program Code	Special Function	Program Code
Input Level Range (except DC Level)		Notch Tune	
Automatic Selection	1.0SP	Automatic notch tuning	6.0SP
300V range	1.1SP	Hold notch tuning	61SP
189V range	1.2SP		
119V range	1.3SP	SINAD Meter Range	
7.54V range	1.4SP	0 to \approx 18 dB range	7.0SP
47.6V range	1.5SP	0 to \approx 24 dB range	7.1SP
30.0V range	1.6SP		
18.9V range	1.7SP	Error Disable	
11.9V range	1.8SP	All errors enabled	8.0SP
7.54V range	1.9SP	Disabled Analyzers errors	8.1SP
4.76V range	1.10SP	(Errors 12-17, 31, and 96)	
3.00V range	1.11SP	Disable source errors	8.2SP
1.89V range	1.12SP	(Errors 18 and 19)	
1.19V range	1.13SP	Disable both Analyzer and	
0.754V range	1.14SP	Source errors	8.3SP
0.476V range	1.15SP		
0.300V range	1.16SP	Hold Settings	
0.189V range	1.17SP	Hold input level ranges,	
0.119V range	1.18SP	post-notch gain, decimal point	
0.0754V range	1.19SP	and notch tuning at present settings.	9.0SP
Input Level Range (DC Level only)		Display Source Settings	
Automatic Selection	2.0SP	Display source settings as	
300V range	2.1SP	entered. Frequency in left	
64V range	2.2SP	display; amplitude in right display.	10.0SP
16V range	2.3SP		
4V range	2.4SP	Re-enter Ratio Mode	
Post Notch Gain		Restore last RATIO reference	
Automatic Selection	3.0SP	and enter RATIO mode if allowed.	11.0SP
0 dB gain	3.1SP	Display RATIO reference	11.1SP
20 dB gain	3.2SP		
40 dB gain	3.3SP	Signal-to-Noise Measurements Delay	
60 dB gain	3.4SP	Automatic Selection	12.0SP
Hold Decimal Point		200 ms delay	12.1SP
Automatic Selection	4.0SP	400 ms delay	12.2SP
DDDD. range	4.1SP	600 ms delay	12.3SP
DDD.D range	4.2SP	800 ms delay	12.4SP
DD.DD range	4.3SP	1.0s delay	12.5SP
D.DDD range	4.4SP	1.2s delay	12.6SP
0.DDDD range	4.5SP	1.4s delay	12.7SP
DD.DD mV range	4.6SP	1.6s delay	12.8SP
D.DDD mV range	4.7SP	1.8s delay	12.9SP
0.DDDD mV range	4.8SP	X-Y Recorder	
		Enable plot	13.0SP
		Disable plot	13.1SP

Table 3-8. Audio Analyzer Special Function to HP-IB Code Summary (2 of 2)

Special Function	Program Code	Special Function	Program Code
Post Notch Detector Response (except in SINAD)		Time Between Measurements	
Fast RMS Detector	5.0SP	Minimum time between measurements	14.0SP
Slow RMS Detector	5.1SP	Add 1s between measurements	14.1SP
Fast AVG Detector	5.2SP		
Slow AVG Detector	5.3SP	Read Display to HP-IB	
Quasi-peak Detector	5.7SP	Read right display	20.0SP
		Read left display	
SINAD and Signal-to-Noise Display Resolution		HP-IB Address	
0.01 dB above 25 dB;	16.0SP	Displays HP-IB address (in binary) in left display; right display in form TLS where T=1 means talk only; L=1 means listen only; S=1 means SRQ	21.0SP
0.5 dB below 25 dB			
0.01 dB all ranges	16.1SP	Displays HP-IB address in decimal	21.1SP
Sweep Resolution (maximum 255 points/sweep)		HP-IB Service Request Condition	22.NSP
10 points/decade	17.0SP	Enable a Condition to cause a service request, N is the sum of any combination of the weighted conditions below:	
1 point/decade	17.1SP	1-Data Ready	
2 points/decade	17.2SP	2-HP-IB error	
5 points/decade	17.3SP	4-Instrument error	
10 points/decade	17.4SP	The instrument powers up in the 22.2 state (HP-IB error).	
20 points/decade	17.5SP		
50 points/decade	17.6SP	Source Output Impedance	
100 points/decade	17.7SP	(Instrument powers up at 600Ω)	
200 points/decade	17.8SP	600Ω	47.0SP
500 points/decade	17.9SP	50Ω	47.1SP
Display Level in Watts			
Display level as watts into 8Ω	19.0SP		
Display level as watts into NNNΩ	19.NNNSP		

Table 3-9. Commonly-Used Code Conversions

ASCII	Binary	Octal	Decimal	Hexa-decimal
NUL	00 000 000	000	0	00
SOH	00 000 001	001	1	01
STX	00 000 010	002	2	02
ETX	00 000 011	003	3	03
EOT	00 000 100	004	4	04
ENQ	00 000 101	005	5	05
ACK	00 000 110	006	6	06
BEL	00 000 111	007	7	07
BS	00 001 000	010	8	08
HT	00 001 001	011	9	09
LF	00 001 010	012	10	0A
VT	00 001 011	013	11	0B
FF	00 001 100	014	12	0C
CR	00 001 101	015	13	0D
SO	00 001 110	016	14	0E
SI	00 001 111	017	15	0F
DLE	00 010 000	020	16	10
DC1	00 010 001	021	17	11
DC2	00 010 010	022	18	12
DC3	00 010 011	023	19	13
DC4	00 010 100	024	20	14
NAK	00 010 101	025	21	15
SYN	00 010 110	026	22	16
ETB	00 010 111	027	23	17
CAN	00 011 000	030	24	18
EM	00 011 001	031	25	19
SUB	00 011 010	032	26	1A
ESC	00 011 011	033	27	1B
FS	00 011 100	034	28	1C
GS	00 011 101	035	29	1D
RS	00 011 110	036	30	1E
US	00 011 111	037	31	1F
SP	00 100 000	040	32	20
!	00 100 001	041	33	21
"	00 100 010	042	34	22
#	00 100 011	043	35	23
\$	00 100 100	044	36	24
%	00 100 101	045	37	25
&	00 100 110	046	38	26
'	00 100 111	047	39	27
(00 101 000	050	40	28
)	00 101 001	051	41	29
*	00 101 010	052	42	2A
+	00 101 011	053	43	2B
,	00 101 100	054	44	2C
-	00 101 101	055	45	2D
.	00 101 110	056	46	2E
/	00 101 111	057	47	2F
0	00 110 000	060	48	30
1	00 110 001	061	49	31
2	00 110 010	062	50	32
3	00 110 011	063	51	33
4	00 110 100	064	52	34
5	00 110 101	065	53	35
6	00 110 110	066	54	36
7	00 110 111	067	55	37
8	00 111 000	070	56	38
9	00 111 001	071	57	39
:	00 111 010	072	58	3A
;	00 111 011	073	59	3B
<	00 111 100	074	60	3C
=	00 111 101	075	61	3D
>	00 111 110	076	62	3E
?	00 111 111	077	63	3F

ASCII	Binary	Octal	Decimal	Hexa-decimal
@	01 000 000	100	64	40
A	01 000 001	101	65	41
B	01 000 010	102	66	42
C	01 000 011	103	67	43
D	01 000 100	104	68	44
E	01 000 101	105	69	45
F	01 000 110	106	70	46
G	01 000 111	107	71	47
H	01 001 000	110	72	48
I	01 001 001	111	73	49
J	01 001 010	112	74	4A
K	01 001 011	113	75	4B
L	01 001 100	114	76	4C
M	01 001 101	115	77	4D
N	01 001 110	116	78	4E
O	01 001 111	117	79	4F
P	01 010 000	120	80	50
Q	01 010 001	121	81	51
R	01 010 010	122	82	52
S	01 010 011	123	83	53
T	01 010 100	124	84	54
U	01 010 101	125	85	55
V	01 010 110	126	86	56
W	01 010 111	127	87	57
X	01 011 000	130	88	58
Y	01 011 001	131	89	59
Z	01 011 010	132	90	5A
[01 011 011	133	91	5B
\	01 011 100	134	92	5C
]	01 011 101	135	93	5D
^	01 011 110	136	94	5E
_	01 011 111	137	95	5F
`	01 100 000	140	96	60
a	01 100 001	141	97	61
b	01 100 010	142	98	62
c	01 100 011	143	99	63
d	01 100 100	144	100	64
e	01 100 101	145	101	65
f	01 100 110	146	102	66
g	01 100 111	147	103	67
h	01 101 000	150	104	68
i	01 101 001	151	105	69
j	01 101 010	152	106	6A
k	01 101 011	153	107	6B
l	01 101 100	154	108	6C
m	01 101 101	155	109	6D
n	01 101 110	156	110	6E
o	01 101 111	157	111	6F
p	01 110 000	160	112	70
q	01 110 001	161	113	71
r	01 110 010	162	114	72
s	01 110 011	163	115	73
t	01 110 100	164	116	74
u	01 110 101	165	117	75
v	01 110 110	166	118	76
w	01 110 111	167	119	77
x	01 111 000	170	120	78
y	01 111 001	171	121	79
z	01 111 010	172	122	7A
{	01 111 011	173	123	7B
	01 111 100	174	124	7C
}	01 111 101	175	125	7D
~	01 111 110	176	126	7E
DEL	01 111 111	177	127	7F

AC Level

DESCRIPTION

The Audio Analyzer contains a wideband, true rms, and average-responding voltmeter with high accuracy and sensitivity. The AC LEVEL key causes the Audio Analyzer to measure the differential ac voltage between its HIGH and LOW INPUT connectors. Signals that are common to both the HIGH and LOW connectors are rejected.

PROCEDURE

To make an ac level measurement, press the AC LEVEL key. AC level results can be displayed in V, mV, dBm into 600Ω, watts, or as the ratio to an entered or measured value. The Audio Analyzer powers up displaying ac level in linear units (mV or V). To obtain a display in dBm (that is, dB relative to 1 milliwatt into a 600Ω load, equivalent to dBre 0.775V), press the LOG/LIN key. To return to linear, simply press the LOG/LIN key again. If the ac level is to be displayed relative to a reference, refer to *RATIO and LOG/LIN*.

EXAMPLE

To measure the ac level of a signal at the INPUT jacks:

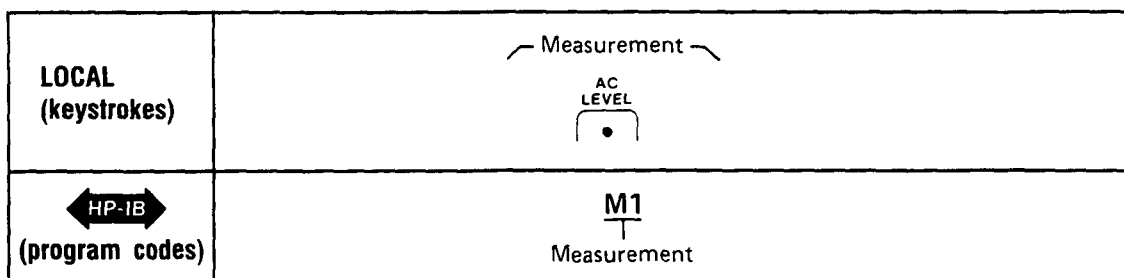

PROGRAM CODE

 M1 is the program code for AC LEVEL.

INDICATIONS

When ac level is selected, the LED within the AC LEVEL key will light. The right display shows the ac level with the appropriate units. The Audio Analyzer automatically ranges for maximum resolution and accuracy. The left display shows the input signal frequency. If the input level to the frequency counter is too small, the left display will show 0.000 kHz. (This will often occur when the signal is in the stop band of the optional high-pass or weighting bandpass filters, but not the low-pass filters.)

MEASUREMENT TECHNIQUE

In ac level the Audio Analyzer acts as an ac voltmeter. The Audio Analyzer automatically sets the input attenuation and the gain settings of the various amplifiers so that the input signal amplitude lies within the range of the output detector. The output detector converts the ac level to a dc voltage which is then measured by the dc voltmeter. After correcting input gain and attenuation, the signal level is displayed in appropriate units. The frequency of the input signal level is also measured and displayed.

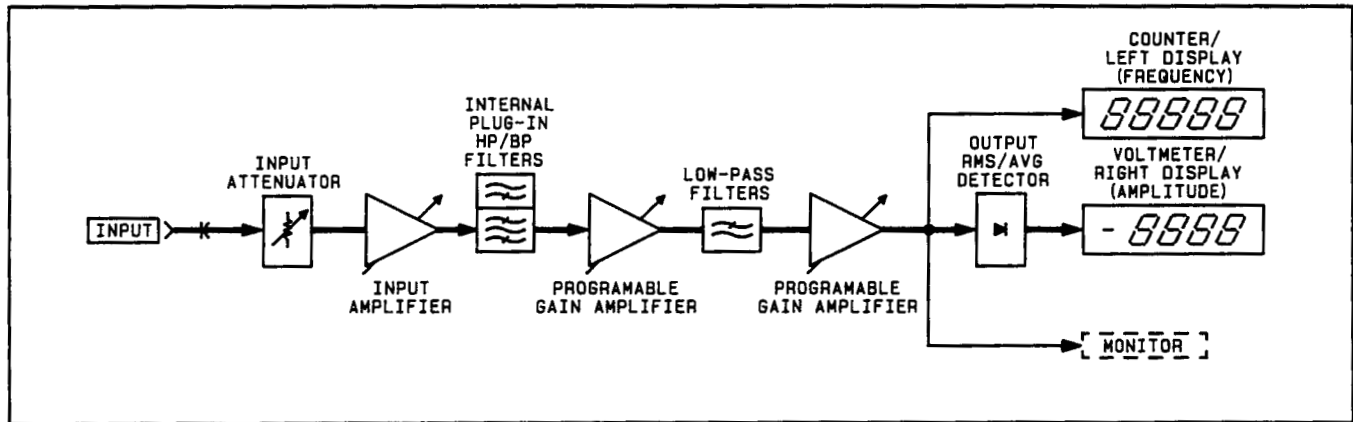

AC Level Measurement Block Diagram

COMMENTS

The Audio Analyzer powers up in the ac level measurement mode with the 80 kHz low-pass filter activated. The 80 kHz low-pass filter reduces the measurement bandwidth from 750 kHz to 80 kHz.

CAUTION

THE INPUT SIGNAL IS NOT TO EXCEED 300V (EITHER WITH RESPECT TO GROUND OR DIFFERENTIAL).

Some input signal limitations apply to the level of common-mode signals. See the Common Mode detailed operating instruction for details.

NOTE

See the Detector Selection section for more detailed information concerning rms and average detecting.

RELATED SECTIONS

Common Mode
 Detector Selection
 Display Level in Watts
 Filters
 Monitor
 RATIO and LOG/LIN
 Special Functions

Amplitude

DESCRIPTION

The Audio Analyzer contains a low-distortion audio source. The AMPTD key, the numeric data and the unit keys are used to program the output level of the source. The source level can be entered in V, mV, or dBm (that is, dB relative to 1 milliwatt into a 600Ω load, equivalent to dBre 0.775V). The amplitude entered is the open-circuit value. The output impedance can be either 600Ω or 50Ω. The AMPTD key is also used to display the currently programmed output level. The amplitude range is 0.6 mV to 6V. The maximum resolution is better than 0.3%.

PROCEDURE

To set the source output level press the AMPTD key and then the appropriate numeric data and unit keys. Once the AMPTD key has been pressed, new data and unit entries can be made to select different amplitudes until another source function key (for example, the FREQ key) is pressed. To display the currently programmed amplitude press and hold the AMPTD key.

EXAMPLE

To set the source output level to 1.5V:

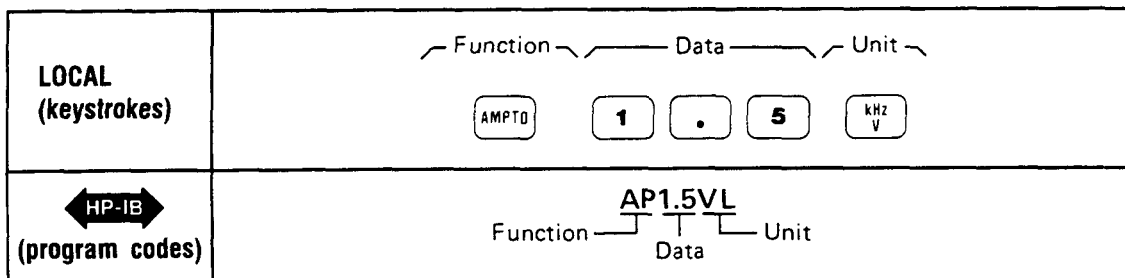

PROGRAM CODE

 AP is the program code for the AMPTD key.

INDICATIONS

When the AMPTD key is pressed, the right display shows the currently programmed output level. As the new output level data is entered, it will appear on the left display. When the units key is pressed, the left display returns to show the input signal frequency. When the amplitude is set to 0V, the output is set to zero but the oscillator remains on.

COMMENTS

The Audio Analyzer powers up with the source frequency set to 1 kHz and amplitude set at 0V.

NOTE

When the source output is set to 0V, maximum output attenuation is not necessarily selected (to minimize wear on the output attenuator). If full output attenuation is not selected, then noise is not held to a minimum level. For minimum noise, first select 6 mV source output, then select 0V.

When the AMPTD key is pressed and held, the right display shows the currently programmed amplitude. It is important to realize that the value shown in the right display is the programmed value which can differ from the actual value at the OUTPUT. For example, when the source output impedance is 600Ω , the voltage developed across an external 600Ω load will be half the programmed value.

RELATED SECTIONS

Display Source Settings
Frequency
Increment
Output Impedance

Automatic Operation

DESCRIPTION

The AUTOMATIC OPERATION key sets the instrument functions to automatic (that is, each function is allowed to automatically range to the appropriate setting). It also cancels all functions that light the SPCL key light.

PROCEDURE

To set the Audio Analyzer to automatic operation, press the AUTOMATIC OPERATION key.

EXAMPLE

To set the Audio Analyzer to automatic operation:

<p>LOCAL (keystrokes)</p>	<p>AUTOMATIC OPERATION</p> 
<p>↔ HP-IB ↔ (program codes)</p>	<p>AU Function</p>

PROGRAM CODE

↔ HP-IB ↔ AU is the HP-IB code for AUTOMATIC OPERATION.

INDICATIONS

When the key is pressed, the right display blanks and then shows four dashes. When the key is released, the display is dependent upon the current measurement mode and input.

COMMENTS

If the Audio Analyzer is in the 10.0 Special Function (Display Source Settings), the instrument returns to the ac level measurement mode.

The converse of the automatic operation mode is the Hold Settings Special Function (prefixed 9). Refer to *Hold Settings*.

For information on which specific Special Functions are turned off by the AUTOMATIC OPERATION key, refer to *Special Functions*. Since AUTOMATIC OPERATION affects Special Functions, it is a good practice to place the AU code at the beginning of a program string when programming the instrument.

RELATED SECTIONS

Display Source Settings
Hold Settings
Special Functions

Common Mode

DESCRIPTION

Common-mode rejection ratio, or “common-mode” as it is usually referred to, is a measure of the ability of an amplifier to reject signals that are common to both amplifier inputs while allowing the differential signal (which may or may not be the weaker signal) to be amplified and passed on to the measurement circuitry.

Since the analyzer input is fully balanced, it can reject signals which are common to the HIGH and LOW inputs (with the INPUT FLOAT switch in the FLOAT position). However, for valid measurement results, there are limitations to the maximum level of common-mode signals.

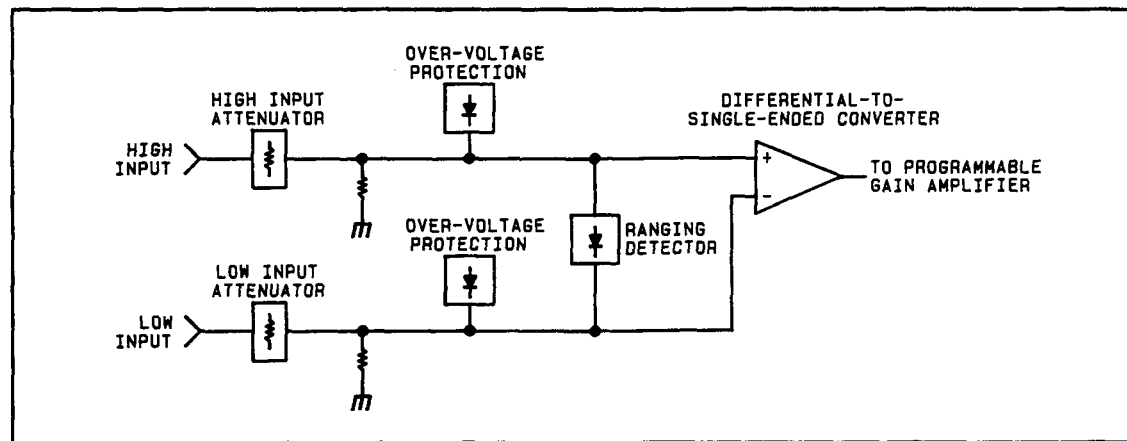

Analyzer Input Block Diagram

Common-mode signal limitations exist because the instrument's ranging detector (which determines the input voltage range), is designed to read only the **differential** signal (between the high and low inputs). Thus, the instrument can set an incorrect input range if a large common-mode signal is present. Erroneous measurements may be obtained as a result.

The block diagram above illustrates that the ranging detector senses the voltage difference between the HIGH and LOW input lines. Common-mode signals are “ignored” by the ranging detector, while differential signals are measured. The block diagram also illustrates that the HIGH and LOW input lines have over-voltage protection circuits *that open when the input voltage (differential, or combined common-mode and differential) exceeds 300V.*

EXAMPLE

If a common-mode signal of 10V is on the analyzer's inputs with a 1V differential signal, the ranging detector selects the 1.19V range. The signal that is present on each input is actually 11V (10V common-mode signal + the 1V differential signal). A voltage signal this large can exceed the input amplifier's operating range and cause erroneous measurements. However, the instrument will not be damaged because the Over-Voltage Protection circuitry will open whenever the combined common-mode and differential signals exceed the instrument's safe operating range. (Selecting Special Function 1.8 will set the input range to 11.9V.)

COMMENTS

For error-free measurements, the *Operating Region For Valid Measurement* graphs, shown below, indicate the maximum allowable common-mode input voltages for a given differential input voltage. Case 1 is for a single-ended source with a common-mode signal present on both input lines. Case 2 is for a balanced source with common-mode signals on both input lines.

To obtain the maximum common-mode input voltage level from the graphs, select the desired value for the differential input voltage. Then read the common-mode input voltage level.

For example, on the Case 1 graph, for a differential input voltage level of 1V, the maximum common-mode input voltage level is 2.8V. For a differential input voltage of 60V, the maximum common-mode input voltage level is 60V.

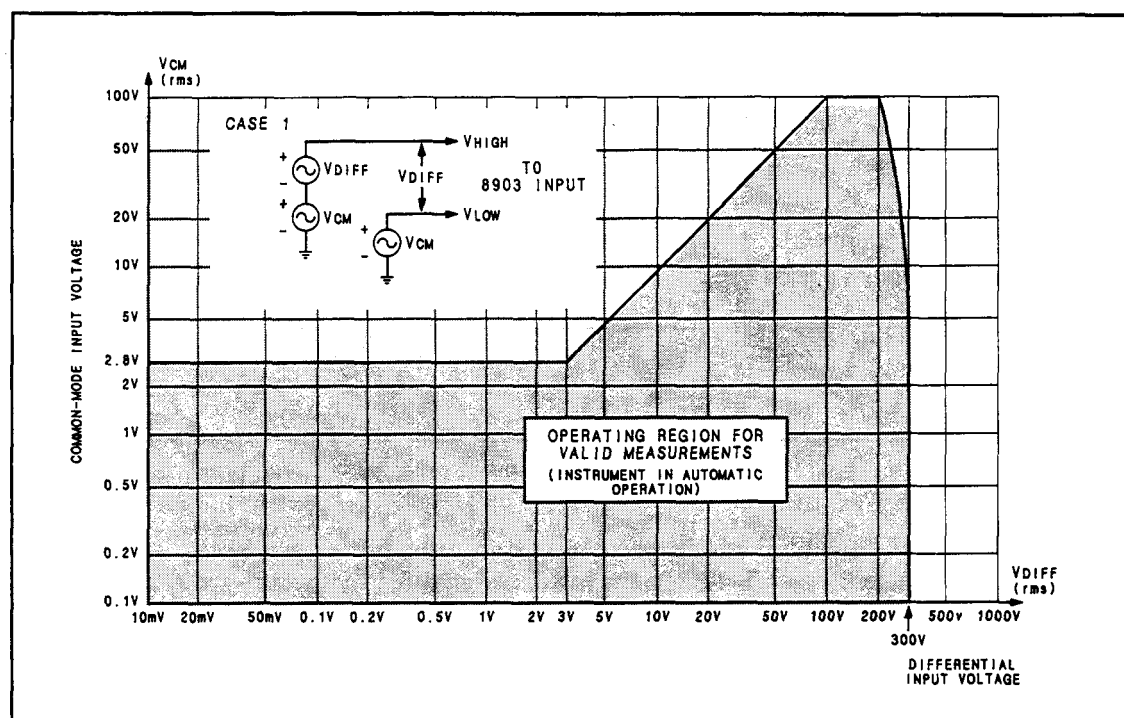

CASE 1. Single-Ended Source with Common Mode on Both Lines

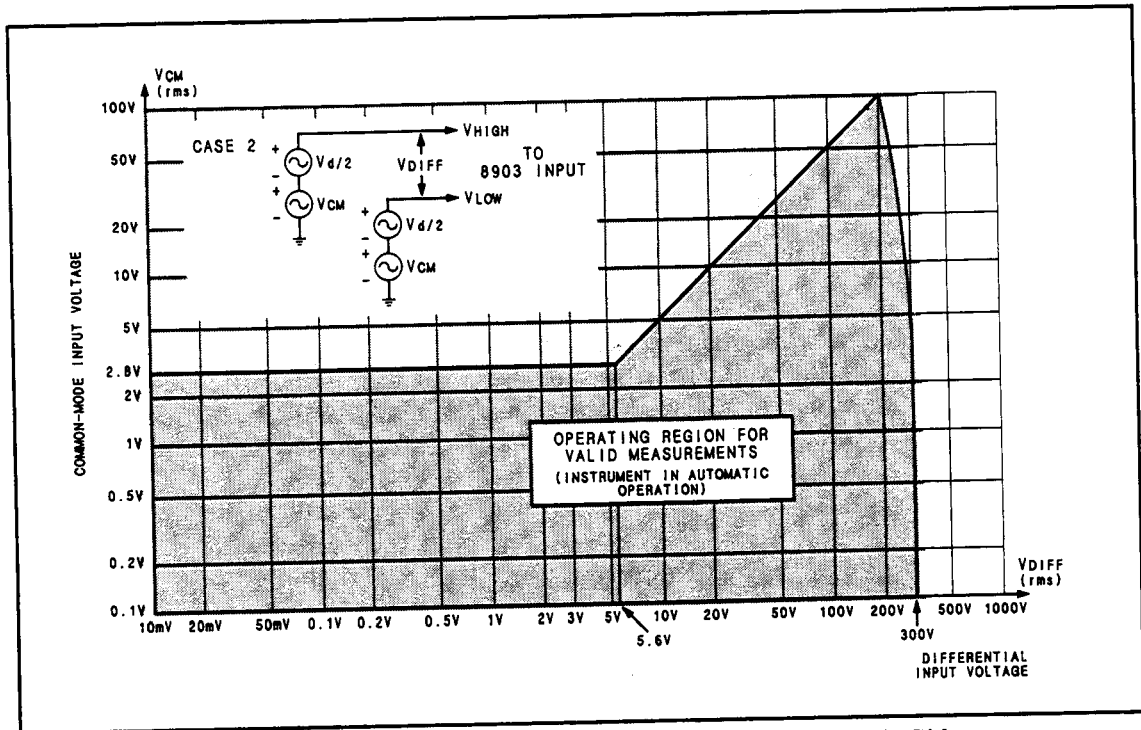

CASE 2. Balanced Source with Common Mode on Both Sides

RELATED SECTIONS

- AC Level
- DC Level

DC Level

DESCRIPTION



The DC LEVEL key causes the Audio Analyzer to measure the differential dc voltage between its HIGH and LOW INPUT connectors. Signals that are common to both the HIGH and LOW connectors are rejected.

PROCEDURE

To make a dc level measurement, press the S (Shift) key, then the DC LEVEL key. The voltage can be expressed in either volts, or, if the voltage is positive, in dBm (that is, dB relative to 1 milliwatt into 600Ω). To obtain a display in dBm, press the LOG/LIN key. To return to linear, simply press the LOG/LIN again. If the dc level is to be displayed relative to a reference level, refer to RATIO and LOG/LIN.

EXAMPLE

To measure the dc level at the INPUT connectors:

LOCAL (keystrokes)	
 (program codes)	S1 T Measurement

PROGRAM CODE

 S1 is the HP-IB code for DC LEVEL.

INDICATIONS

When dc level is selected, the LEDs within the DC LEVEL key and the S (Shift) key will light. The right display shows the dc level with the appropriate units. The Audio Analyzer automatically ranges for maximum resolution and accuracy. In the dc level measurement mode the left display is blanked even though an ac signal may be present.

MEASUREMENT TECHNIQUE

In the dc level measurement mode the Audio Analyzer automatically sets the input attenuation and the gain of the input amplifier so that the signal amplitude lies within the proper range of the dc voltmeter. The signal is then measured by the dc voltmeter and after correction for input gain and attenuation, displayed in appropriate units.

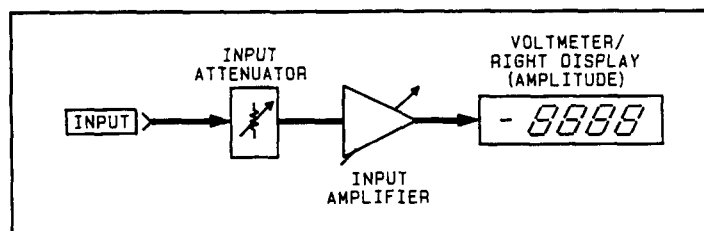

DC Level Measurement Block Diagram

COMMENTS**CAUTION**

THE INPUT SIGNAL IS NOT TO EXCEED 300V (WITH RESPECT TO GROUND OR DIFFERENTIAL).

Some input signal limitations apply to the size of the common-mode signals. See the Common-Mode detailed operating instruction for details.

In the dc level measurement mode only the ac component of the input signal is coupled to the MONITOR output. The ac component also affects the input gain.

RELATED SECTIONS

Common Mode
RATIO and LOG/LIN
Special Functions

Default Conditions and Power-up Sequence

DESCRIPTION

When first turned on, the Audio Analyzer performs a sequence of internal checks after which the instrument is ready to make measurements. During the power-up sequence, all front-panel indicators light to allow the operator to determine if any are defective. After approximately four seconds, this sequence is completed and the Audio Analyzer is preset as follows:

START FREQ	20 Hz
STOP FREQ	20 kHz
PLOT LIMIT	
LOWER LIMIT	-100.0
UPPER LIMIT	100.0
FREQ	1000.0 Hz
FREQ INCR	1000.0
AMPTD	0.00 mV
AMPTD INCR	0.100V
MEASUREMENT	AC LEVEL
DETECTOR	RMS
LP FILTER	LOW PASS 80 kHz
HP/Weighting BP Filter	Off
RATIO	Off
Ratio Reference	0
LOG/LIN	LIN ¹
Left Display	Input Frequency
Right Display	Input AC Level
Source Output Impedance	600Ω
Service Request Condition	HP-IB Code Error Only
Status Byte	Cleared
Trigger Mode	Free Run (Code TO)
SPCL	All Special Functions OFF or in their zero suffix ²
Plotter	Enable
X AXIS, Y AXIS	0V
PEN LIFT	TTL high

NOTE

The two Front-Panel FLOAT switches are set manually.

RELATED SECTIONS

RATIO and LOG/LIN
Service Request Condition

¹ See *RATIO* and *LOG/LIN* Detailed Operation Sections.

² Except Service Request Condition which is set to 22.2 (HP-IB Code Error)

Detector Selection

DESCRIPTION

The Audio Analyzer contains a high accuracy, wide-band, voltmeter with three types of detectors; true rms, average-responding, and quasi-peak.

PROCEDURE

To select the true RMS Detector press 5.0 SPCL for fast rms detection, or 5.1 SPCL for slow rms detection.

To select the Average Detector, press 5.2 SPCL for fast average detection, or 5.3 SPCL for slow average detection.

To select the Quasi-peak Detector press 5.7 SPCL for quasi-peak detection.

EXAMPLE

Detector	Special Function Code	Program Code ↔ HP-IB ↔
rms	5.0 SPCL	A0 or 5.0SP
average	5.2 SPCL	A1 or 5.2SP
quasi-peak	5.7 SPCL	5.7SP

PROGRAM CODES



A0 is the HP-IB code for RMS Detector. A1 is the HP-IB code for Average Detector. The Quasi-peak Detector HP-IB program code is 5.7 SP.

INDICATIONS

When 5.0 SPCL is entered, there is no change in the instrument display since rms detection is the default at power up. When 5.1 SPCL is entered, the SPCL key light is lit to indicate a special function has been selected (slow rms detection).

When 5.2 SPCL (fast average detection), 5.3 SPCL (slow rms detection), or 5.7 SPCL (quasi-peak detection) is entered, the SPCL key light is lit to indicate a special function has been selected.

MEASUREMENT TECHNIQUE

When measuring complex waveforms or noise, a true rms detector will provide a more accurate measurement result than an average-responding detector that has been calibrated to indicate the rms value. For a sine wave, both the true rms and the average-responding detectors give correct rms readings. However, when the signal is a complex waveform, or when significant noise is present, the average-responding detector reading can be in error. The amount of error depends upon the particular signal being measured. For noise, an average-responding detector reads low.

The Quasi-peak Detector, which has a fast rise time coupled with a slow decay time is used to “capture” impulse type signals or other signals (noise or waveforms with high crest factors.) The Quasi-peak Detector, when used with the optional CCIR weighting Filter gives signal-to-noise measurement results which more accurately correlates with perceived signal-to-noise ratios.

COMMENTS

Many ac voltmeters employ an average-responding detector. For those applications requiring the use of an average-responding detector, select either 5.2 SPCL (for fast average) or 5.3 SPCL (for slow average) special functions. One feature of the Quasi-peak Detector is that the displayed response drops as the repetition rate of the measured signal decreases. Because there is only one Quasi-peak Detector (part of the Output Detector), you will not get meaningful measurements for Distortion or SINAD. Using the Quasi-peak Detector for Distortion or SINAD measurements is not recommended.

RELATED SECTIONS

AC Level
Distortion
Distortion Level
SINAD
Signal-to-Noise

Display Level in Watts (Special Function 19)

DESCRIPTION

The measurement mode can be set to read the ac input power in watts into a specified external load resistance by using Special Function 19. The range of the selectable load resistance (in ohms) is an integer value from 1 to 999.

PROCEDURE

To set the measurement to display the ac level in watts into a specified resistance, key in the corresponding Special Function code then press the SPCL key.

Resistance (Ω)	Special Function Code	Program Code
8 1—999	19.0 SPCL 19.NNN SPCL (where NNN corresponds to the load resistance in ohms)	19.0SP 19.NNNSP

EXAMPLE

To set the right display to read INPUT signal level in watts into an external 16 Ω speaker:

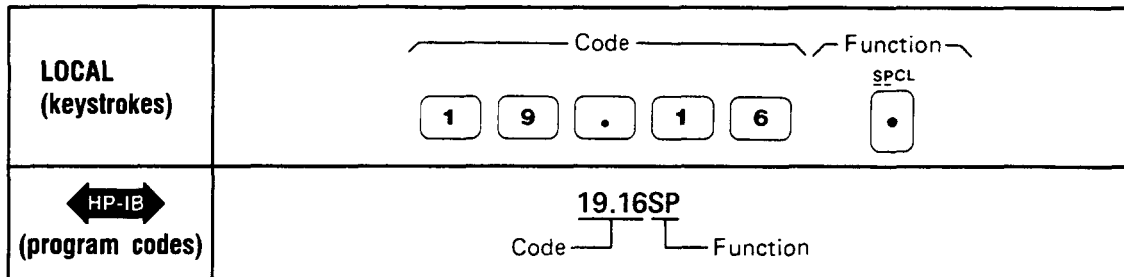

PROGRAM CODES

For HP-IB codes, refer to *Procedure* above.

INDICATIONS

As the numeric code is entered, both displays will blank and the entered code will appear in the left display. When the SPCL key is pressed, the SPCL key will light if it is not already on. If it is on, it will remain on. The right display shows a four-digit readout of the ac power in watts but no units are indicated. All measurement LEDs go off.

COMMENTS

The load resistance in ohms must be an integer (for example, a resistance of 5.8 Ω cannot be entered). The decimal point has already been used when entering the Special Function. An attempt to enter a second decimal point is ignored.

Remember that the instrument assumes that the input voltage is being developed across the specified external load resistance. If an incorrect resistance is entered, the readout in watts is shown for the resistance entered.

Zeros immediately following the decimal point are optional. For example, when setting the load resistance to 1Ω , 19.1 is equivalent to 19.01 and 19.001. However, 19.1 is not equivalent to 19.10 or 19.100. Note that 19., 19.0, and 19.8 are equivalent (that is, they all specify an 8Ω load resistance).

The displayed power level is accurate regardless of distortion unless the Audio Analyzer's audio detector is set to average responding.

Neither the RATIO nor the LOG function can be used with this Special Function.

RELATED SECTIONS

AC level

Detector Selection

Display Source Settings (Special Function 10)

DESCRIPTION

The currently programmed frequency and amplitude of the source can be simultaneously displayed by using Special Function 10. The programmed frequency is displayed in the left display and the programmed (open-circuit) amplitude is displayed in the right display.

PROCEDURE

To display the currently programmed frequency and amplitude of the source press 10.0 then press the SPCL key.

EXAMPLE

To display the source settings:

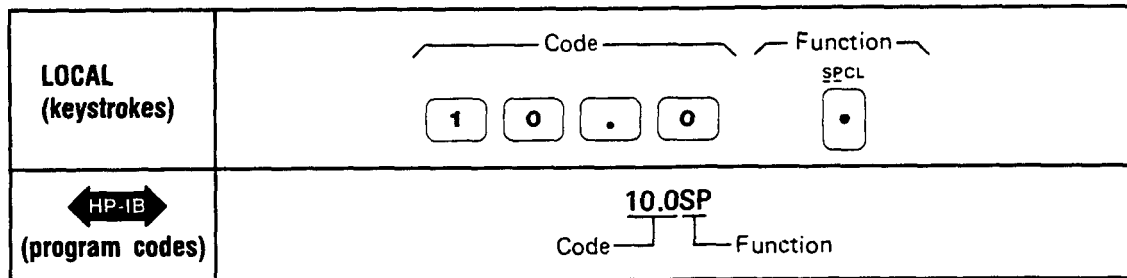

PROGRAM CODES

↔ HP-IB 10.0SP is the HP-IB code for Special Function 10.

INDICATIONS

As the numeric code is entered, both displays will blank, and the entered code will appear in the left display. When the SPCL key is pressed, the SPCL key LED will light if it is not already on. If it is already on, it will remain on. The displays then show the source's currently programmed frequency in the left display and its currently programmed amplitude in the right display.

COMMENTS

It is important to realize that neither display is a measurement of the source output. Therefore, the actual values at the OUTPUT connector may differ from the programmed values. In the case of frequency, there is usually only a very slight difference. In the case of amplitude, the difference is dependent upon the load impedance. For example, if the output impedance is set for 600Ω, a load impedance of 600Ω causes the amplitude at the OUTPUT connector to be half of the programmed value.

RELATED SECTIONS

- Amplitude
- Automatic Operation
- Frequency
- Special Functions

Distortion

DESCRIPTION

The Audio Analyzer measures distortion by first determining the following value:

$$D = \frac{\text{noise} + \text{distortion}}{\text{signal} + \text{noise} + \text{distortion}}$$

It then converts D into the appropriate measurement units as follows:

$$\% \text{ units} = D \times 100 \%$$

$$\text{db units} = 20\log D$$

The **RATIO** key can be used to compare the measured results to a predetermined ratio reference value (refer to *RATIO and LOG/LIN*).

A distortion measurement can be made on signals from 20 Hz to 100 kHz and from 50 mV to 300V.

PROCEDURE

To make a distortion measurement, press the **DISTN** key. If the internal source is to be used as the stimulus signal, key in the desired frequency and amplitude. Use the filters to limit noise, hum, spurious signals, etc. The Audio Analyzer powers up with the **LOW PASS 80 kHz** filter activated.

EXAMPLE

To measure the distortion of an external source in a 30 kHz bandwidth:

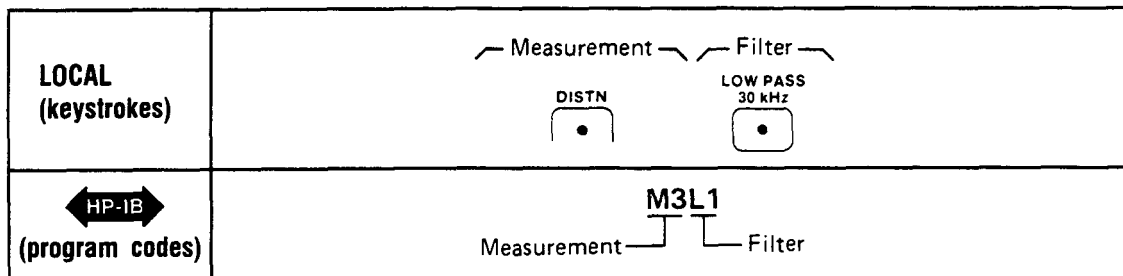

PROGRAM CODE

M3 is the HP-IB code for the distortion measurement.

INDICATIONS

When distortion is selected, the LED within the **DISTN** key will light. The frequency and distortion of the input signal are displayed and the appropriate annunciators are lighted (see *Description* above).

MEASUREMENT TECHNIQUE

In the distortion measurement mode, the controller automatically sets the input attenuation and the gain settings of various amplifiers. This is accomplished by measuring the input signal with the rms range detector. This control ensures that the signal amplitude is within the proper range for the input and output detectors. The input detector converts the ac level of the combined signal + noise + distortion to dc. The notch filter removes the fundamental signal. The notch filter automatically tunes to the component whose frequency is measured by the counter (usually the fundamental of the input signal). The output detector converts the residual noise + distortion to dc. The dc voltmeter measures both dc signals. The controller then corrects for the programmed gain and attenuation, computes the ratio of the two signals, and then displays the results in appropriate units. The frequency of the input signal is also measured and displayed.

COMMENTS

Distortion can be measured with either the true rms or average-responding detector. Most applications specify true rms detection. Using the Quasi-peak Detector for Distortion measurements is not recommended.

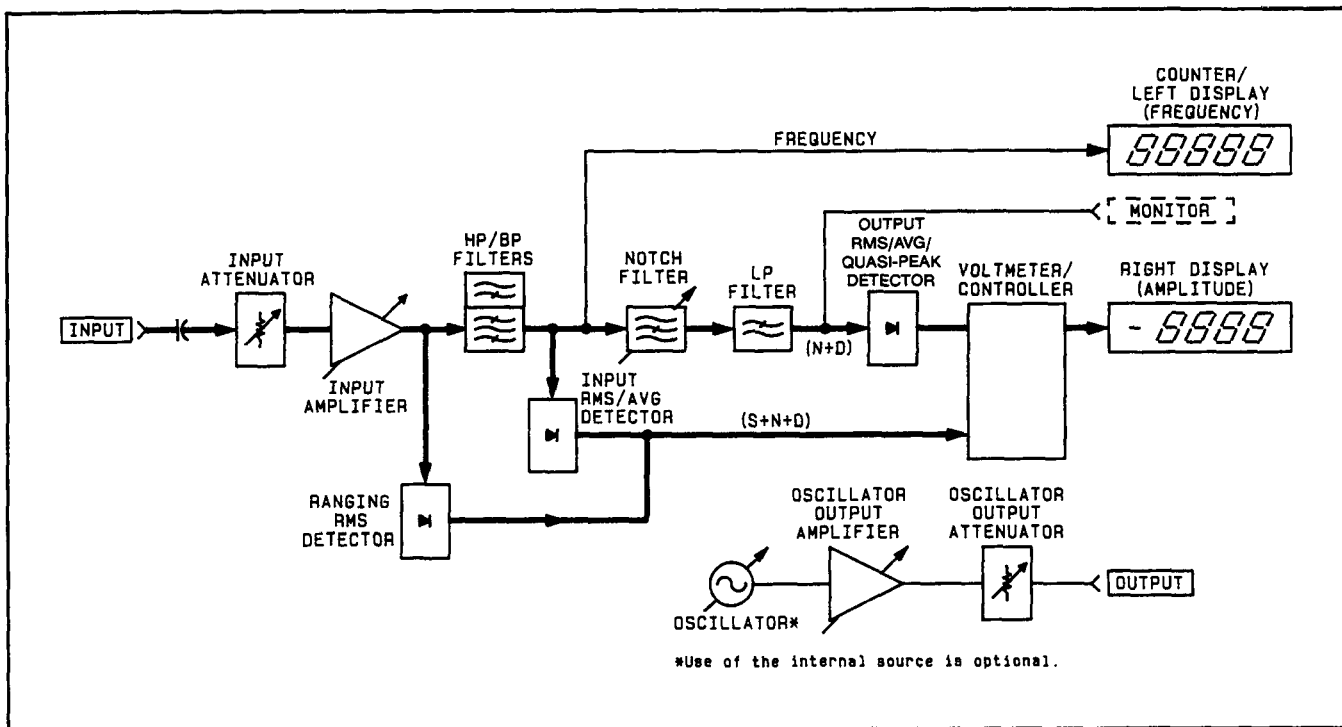

Distortion Measurement Block Diagram

RELATED SECTIONS

- Detector Selection
- Distortion Level
- Filters
- Notch Tune
- RATIO and LOG/LIN

Distortion Level

DESCRIPTION

The Audio Analyzer measures the distortion level by removing the fundamental of the input signal and then measuring the ac level of the remaining noise and distortion. The mV and V units are displayed in the linear mode or the values are converted to dBm (that is, dB relative to 1 milliwatt into 600Ω load equivalent to 0.775V). The **RATIO** key can be used to compare the measured results to a predetermined ratio reference (refer to *RATIO and LOG/LIN*).

PROCEDURE

To make a distortion level measurement, press the **S** (Shift) and **DISTN LEVEL** keys. If the internal source is to be used as a stimulus signal, key in the desired frequency and amplitude. The filters are used to limit the bandwidth. The Audio Analyzer powers up with the **LOW PASS 80 kHz** filter activated.

EXAMPLE

To measure distortion level on an external source signal in a 30 kHz bandwidth:

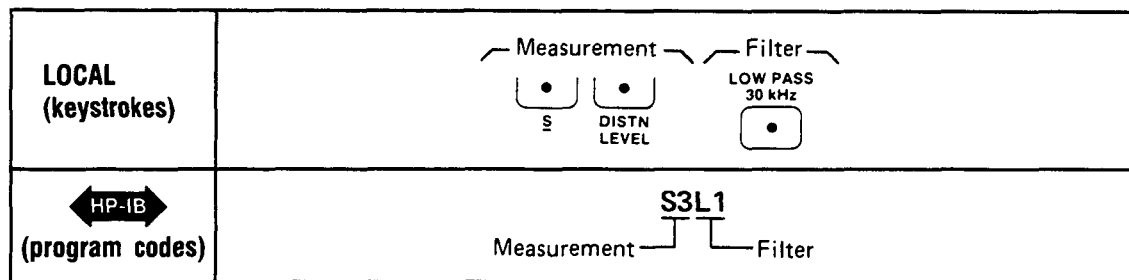

PROGRAM CODE

↔ **HP-IB** ↔ S3 is the HP-IB code for distortion level.

INDICATIONS

When distortion level is selected, the LEDs in the **S** (Shift) key and the **DISTN LEVEL** key will light. The frequency and amplitude of the input signal are displayed and the appropriate annunciators will light (see *Description* above).

MEASUREMENT TECHNIQUE

In the distortion level measurement mode, the controller automatically sets the input attenuation and the gain settings of various amplifiers. This control ensures that the signal amplitude is within the proper range for the output detector. The notch filter removes the fundamental from the input signal. The notch filter automatically tunes to the component whose frequency is measured by the counter (usually the fundamental of the input signal). The output detector converts the residual noise + distortion to dc. The dc voltmeter measures the signal and the controller corrects for the programmed gain and attenuation. The results are then displayed in the appropriate units. The frequency of the input is also measured and displayed.

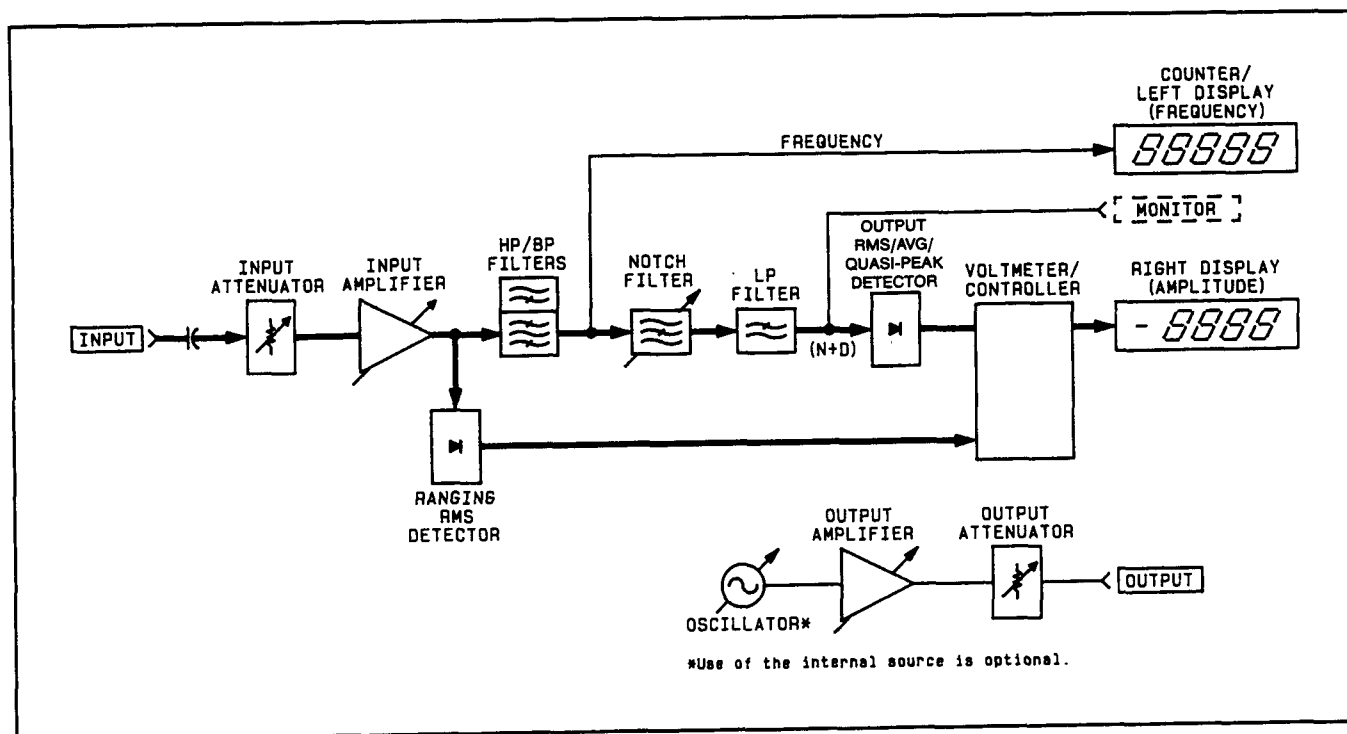

Distortion Level Measurement Block Diagram

RELATED SECTIONS

- Detector Selection
- Distortion
- Filters
- Monitor
- Notch tune
- RATIO and LOG/LIN

Error Disable (Special Function 8)

DESCRIPTION

The Error Disable Function is used to selectively disable operating error messages. Using the 8.N Special Function allows the user to enable all operator error messages, disable analyzer errors (measurement related errors), disable source errors (output related errors), or disable both analyzer and source errors.

PROCEDURE

To selectively disable (or enable) operator error messages, key in the corresponding Special Function code then press the SPCL key.

Error Message Status	Special Function Code	Program Code ↔ HP-IB ↔
All error messages enabled.	8.0 SPCL	8.0SP
Disable analyzer error messages (Errors 12-17, 31, and 96).	8.1 SPCL	8.1SP
Disable source error messages (Errors 18 and 19).	8.2 SPCL	8.2SP
Disable both analyzer and source error messages.	8.3 SPCL	8.3SP

EXAMPLE

To disable the source error messages:

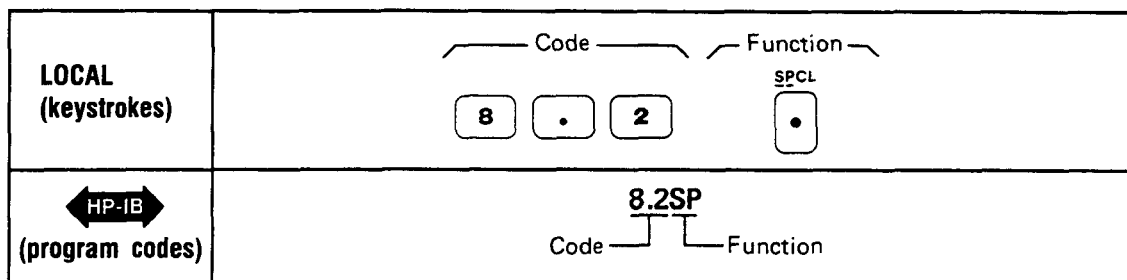

PROGRAM CODES

↔ HP-IB ↔ For HP-IB codes refer to *Procedure* above.

INDICATIONS

As the numeric code is entered, both displays will blank, and the entered code will appear in the left display. When the SPCL key is pressed, the SPCL key will light (except for Special Function 8.0) if it is not already on. If it is already on, it will remain on (except for Special Function 8.0). Both displays then return to the display that is appropriate for the currently selected measurement mode.

COMMENTS

The error messages can be selectively disabled to prevent the analyzer error messages from halting the operation of the source section of the Audio Analyzer, and vice-versa.

The error messages can also be selectively disabled to prevent unwanted error interrupts to the HP-IB bus controller.

Error messages are one means by which the instrument safeguards accurate measurements. When these safeguards are disabled, erroneous measurements can result under certain conditions. This should be kept in mind when operating the instrument with error messages disabled.

RELATED SECTIONS

Automatic Operation
Error Message Summary
Special Functions

Error Message Summary

DESCRIPTION

The instrument generates error messages to indicate operating problems, incorrect keyboard entries, or service related problems. The error message is generally cleared when the error condition is removed. (Error 31 is an exception.) The Error Messages are grouped by error code as follows:

Error 10 through Error 39 and Error 90 through Error 99. These are Operating and Entry Errors which indicate that not all conditions have been met to assure a calibrated measurement or that an invalid key sequence or keyboard entry has been made. Operating Errors can usually be cleared by using the front-panel controls. The Error Disable Special Function (8.N) can be used to selectively disable certain operating error messages. Entry Errors require that a new keyboard entry or function selection be made.

Error 65 through Error 89. These are Service Errors which provide additional service related information. Service Errors must be enabled to appear and do not necessarily represent failures within the instrument. Service Errors are discussed in Section 8, *Service* (volumes 2 and 3).

HP-IB OUTPUT FORMAT

 The HP-IB output format for errors is shown below:

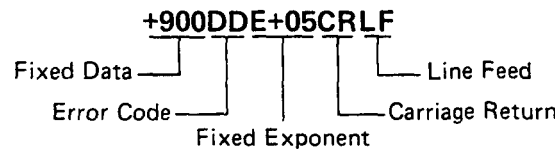

For example, Error 10 is output to the HP-IB as +90010E+05CRLF. This format differs from normal data outputs since normal data outputs will never exceed 4×10^9 . Once an error has been input to the computing controller, the error code is simply derived by subtracting 9×10^9 from the input number, then dividing the result by 100 000.

ERROR DISPLAYS

Shown below and on the next page are three types of error displays. The first is typical of most error displays and is shown as a general case. The second and third have specific meaning and occur often.

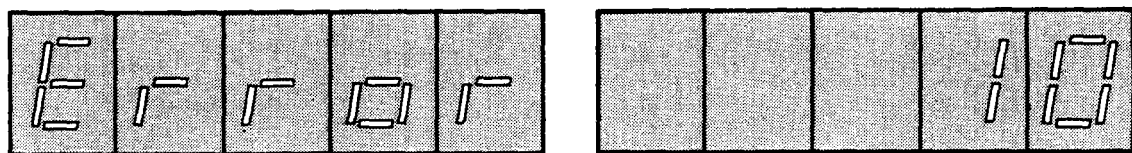

This display shows the general error display format. These errors are output to the HP-IB as shown under the HP-IB format above.

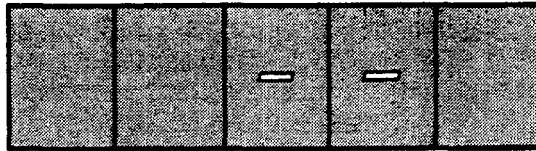

This display means that no signal has been sensed at the input. This display is output to the HP-IB as Error 96 using the HP-IB format shown above.

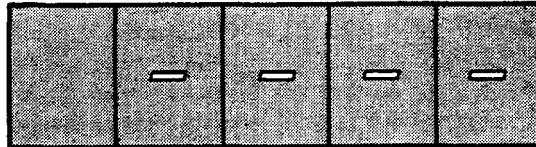

This display means that a signal has been detected but for various reasons a measurement result is not yet available. This display is never output to the HP-IB and typically indicates a transitory state in instrument operation. After nine successive occurrences, the display changes to Error 31. Error 31 is output to the HP-IB using the HP-IB format shown above.

ERROR MESSAGES

The table below describes all Operating and Entry errors. The error code, message, and the action typically required to remove the error-causing condition are given. Additional information pertaining to particular errors is also given.

Error Code	Message	Action Required/Comments
Operating Errors		
10	Reading too large for display.	This error code indicates that although the required calculation is within the capability of the instrument, the result of the calculation exceeds the display capabilities.
11	Calculated value out of range.	Enter new RATIO reference. Refer to <i>RATIO and LOG/LIN</i> .
13	Notch cannot tune to input.	Adjust input frequency to within specified limits. Refer to Table 1-1.
14	Input level exceeds instrument specifications.	This error code indicates that the input overload detector has tripped (not in range hold). This could be caused by too large an ac signal, or too much ac on a dc signal.
NOTE		
<i>Although error codes 17, 18 and 19 are officially listed here under Operating Errors, they should be considered rather as diagnostic indications.</i>		

Error Messages (cont'd)

Error Code	Message	Action Required/Comments
Operating Errors (Cont'd)		
17	Internal voltmeter cannot make measurement.	This error code indicates that the counter has failed to return a value. This can only be caused by a malfunction in the counter. Refer to Service Sheet 14.
18	Source cannot tune as requested	This error code indicates a malfunction in the counter and/or the oscillator. Refer to Service Manual.
19	Cannot confirm source frequency.	This error indicates that in notch routine, the frequency could not be measured, and thus the notch could not be adjusted. This usually indicates a counter problem. Refer to Service Sheet 14.
25	Top and bottom plotter limits are identical.	This error code indicates that the user has entered the same upper and lower limits to scale the sweep of the X-Y plotter output. This would cause a division by zero. The user should enter some realistic plot limits. Refer to <i>X-Y Recording</i> , and, more particularly, to <i>Plot Limit</i> .
26	RATIO not allowed in present mode.	This error code indicates that use of the RATIO key does not make sense in the current mode. Refer to <i>RATIO and LOG/LIN</i> .
30	Input overload detector tripped in range hold.	This error code indicates that the input signal is too high for the selected range. Press CLEAR key and then enter a more realistic range setting, or press AUTOMATIC OPERATION key to allow the Audio Analyzer to seek the correct input range. Refer to <i>Automatic Operation</i> .
31	Cannot make measurement.	This error code indication occurs when the input signal is changing too quickly for the Audio Analyzer to make consistent measurements or when the common mode signal is too large for the Audio Analyzer. The "----" display indicates that the instrument is trying to make a measurement. After nine unsuccessful tries, Error 31 is displayed.
32	More than 255 points total in a sweep.	Although sweep resolution can be changed with Special Function 17, care should be taken to ensure that it will not result in more than 255 points in the total sweep. Refer to Sweep Resolution.
<div style="display: flex; align-items: center;"> <div style="margin-right: 5px;">96</div> <div style="border: 1px solid black; padding: 2px 5px; font-weight: bold;">HP-IB</div> </div>	(HP-IB only) No signal sensed at input.	This error is sent on the HP-IB when the "--" display is shown.

Error Messages (cont'd)

Error Code	Message	Action Required/Comments
Entry Errors		
20	Entered value out of range.	Re-enter new value.
21	Invalid key sequence.	Check for compatibility of functions selected
22	Invalid Special Function prefix.	Check, then re-enter correct Special Function code. Refer to <i>Special Functions</i> .
23	Invalid Special Function suffix.	Check, then re-enter correct Special Function code. Refer to <i>Special Functions</i> .
24 	Invalid HP-IB code.	Check, then re-enter correct HP-IB code. This error causes a Require Service message to be sent on the HP-IB. Refer to Table 3-4 and accompanying text.
Service Errors		
65—89	Service-related errors.	Refer to paragraph 8-12, <i>Service Errors</i> .

RELATED SECTIONS

- Automatic Operation
- Plot Limit
- RATIO and LOG/LIN
- Sweep Resolution
- X-Y Recording

Filters (Low-Pass, High-Pass, Bandpass)

DESCRIPTION

The optional plug-in high-pass and weighting bandpass and the LP (low-pass) FILTER keys cause the respective filters to be inserted into the audio signal path. The filters limit the measurement bandwidth. The high-pass and bandpass filters are inserted before the notch filter (control of the notch filter is covered in the *Notch Tune* discussion). The low-pass filters are inserted after the notch filter. When in use, the high-pass, bandpass, and low-pass filters always affect the signal at the rear-panel MONITOR output.

PROCEDURE

Select the desired signal filters by pressing the appropriate keys. Only one high-pass or bandpass and one low-pass filter can be in use at a time. To turn a filter off, press the key again or select another filter in the same group. HP-IB codes for the different filter keys (shown below) turn on the selected filter (defeating others in the group if on). To turn a high-pass or bandpass or low-pass filter off via HP-IB, use code H0 or L0 respectively, or select the alternate filter in the pair.

EXAMPLE

To select the left high-pass or bandpass filter and the 30 kHz low-pass filter:

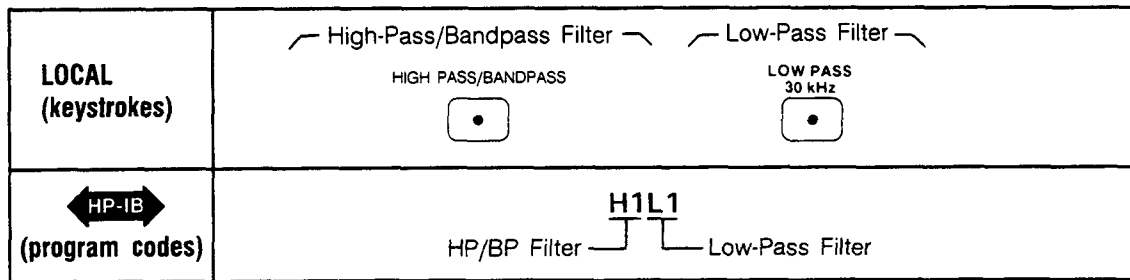

PROGRAM CODES

HP-IB	HP/BP Filter	Program Code 	LP Filter	Program Code
	Both off	H0	Both off (750 kHz low-pass)	L0
	Left HP/BP Filter	H1	LOW PASS 30 kHz	L1
	Right HP/BP Filter	H2	LOW PASS 80 kHz	L2

INDICATIONS

When a filter is activated (by either automatic or manual selection), the LED within that filter's key will light.

COMMENTS

Two plug-in positions within the instrument permit the Audio Analyzer to be configured with various high-pass and band-pass filter combinations. The optional plug-in filter assemblies include a 400 Hz High-Pass (used to filter out 50/60 Hz hum, and squelch signals), and CCITT, CCIR, CCIR/ARM, "A" Weighting, and C-Message Weighting Bandpass Filters. These weighting bandpass filters are all psophometric in nature; each filter characteristic approximates the response of human hearing according to separately established standards.

These optional plug-in filter assemblies may be inserted in either the left-most or right-most key position, according to the filter option number.

Filter	Left-Most Key Position Filter Option Number	Right-Most Key Position Filter Option Number
400 Hz high pass	010	050
CCITT weighting bandpass filter	011	051
CCIR weighting bandpass filter	012	052
C-Message weighting bandpass filter	013	053
CCIR/ARM weighting bandpass filter	014	054
"A" weighting bandpass filter	015	055

The selected filters are always in the path of the audio signal.

With all filters off, the 3 dB measurement bandwidth is approximately 10 Hz to 750 kHz.

The high-pass or bandpass filters affect the signal being counted; however, the low-pass filters do not. Repeating the HP-IB command to turn on a specific filter has no effect (that is, the filters cannot be toggled on and off using the same HP-IB command).

The individual filter characteristics are given in Table 1-1, *Specifications* and in Table 1-2, *Supplemental Information*.

The optional weighting bandpass plug-in filter assemblies weights the frequency response of the Audio Analyzer as shown in their respective curve plots.

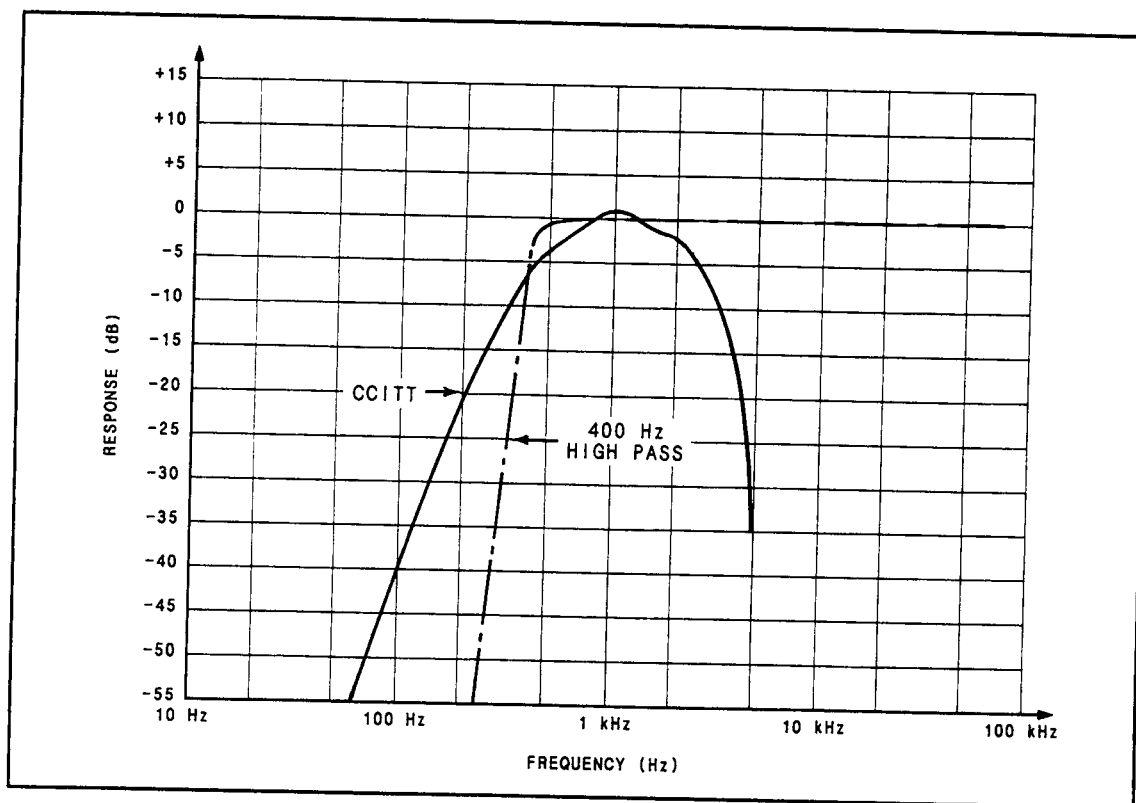

CCITT and 400 Hz High-Pass Filter Plot

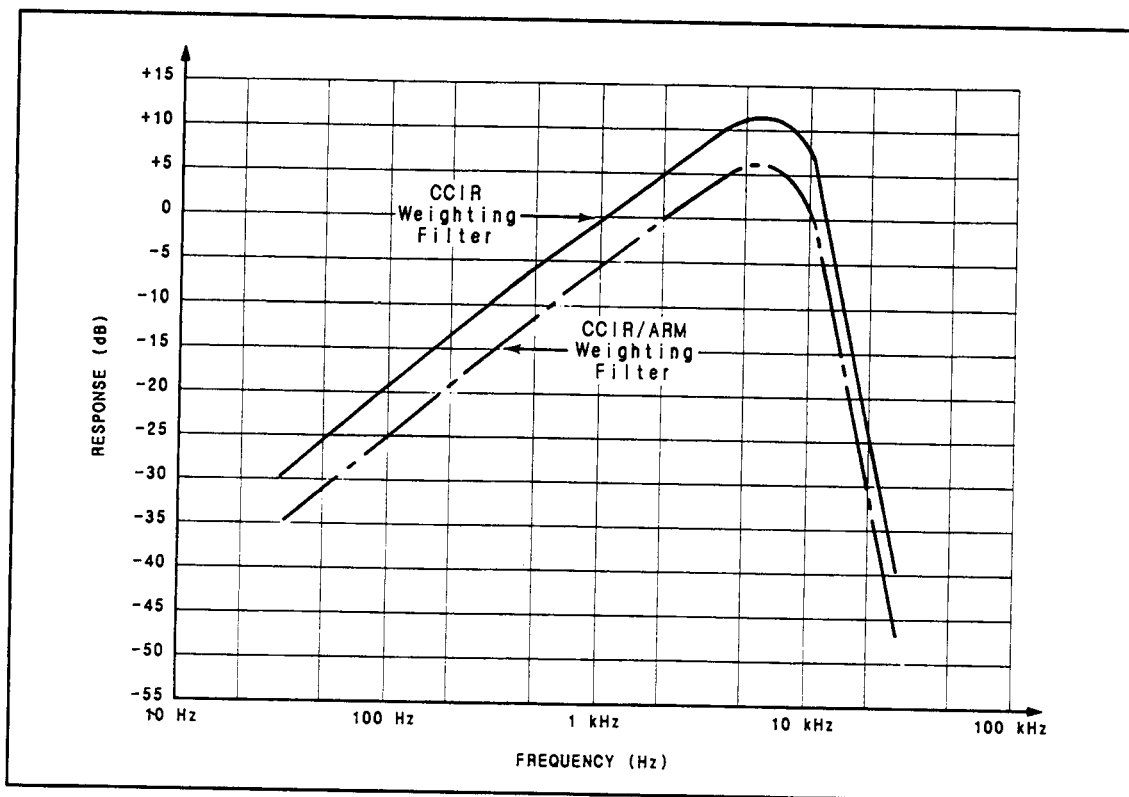

CCIR and CCIR/ARM Weighting Filter Plot

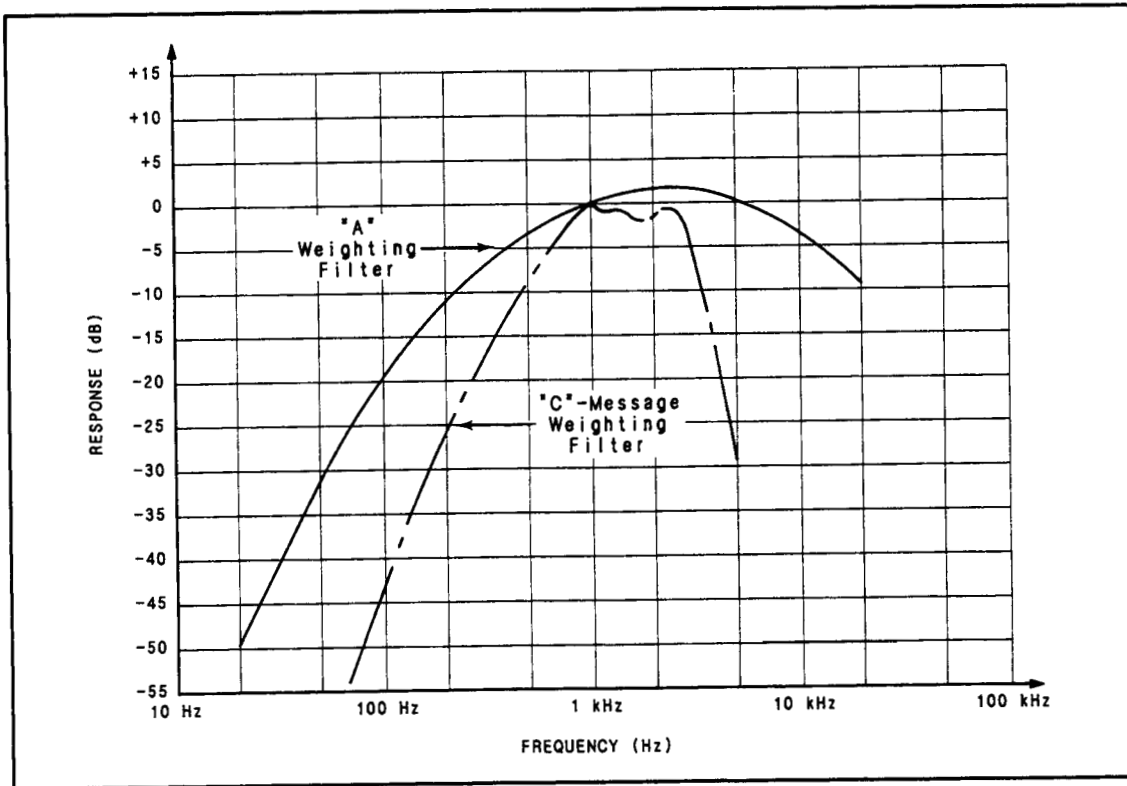

"A" Weighting and "C"-Message Weighting Filter Plot

RELATED SECTIONS

- AC Level
- Distortion
- Distortion Level
- Signal-to-Noise
- SINAD

Float

DESCRIPTION

To minimize measurement errors caused by ground loops, both the source output and the analyzer input can be floated. Floating the input improves rejection of low-frequency and common mode signals (for example, line-related hum and noise). The two front-panel FLOAT switches determine whether the input and output circuitry are floating or single-ended. When the analyzer input is in the float mode, the input is fully balanced. This is not true for the source output when floated.

PROCEDURE

To float either the analyzer input or the source output, set the corresponding FLOAT switch to the FLOAT position. In the float mode the LOW center conductor is isolated from chassis ground. In the single-ended mode (the FLOAT switch in the grounded position) the LOW center conductor is connected directly to chassis ground.

COMMENTS

The INPUT and OUTPUT BNC connectors allow the attachment of shielded cables, which minimize electromagnetic interference (EMI). This is important if the Audio Analyzer is operated near a transmitter or in the presence of large RF signals.

The outer conductor of each BNC connector is connected directly to chassis ground. When the FLOAT switch is in the grounded position the center conductor of the LOW connector is required if a BNC coaxial cable is connected the other HIGH connectors must be connected.

If EMI shielding is not critical, banana-type connectors can be used. Four BNC-to-banana adapters are supplied with the instrument to convert the BNC input and output to a dual banana connector with standard 3/4 inch spacing. The adapters connect the conductor of the banana connector to the center conductor of the BNC connector. These adapters are normally used when the FLOAT switches are set in the FLOAT position.

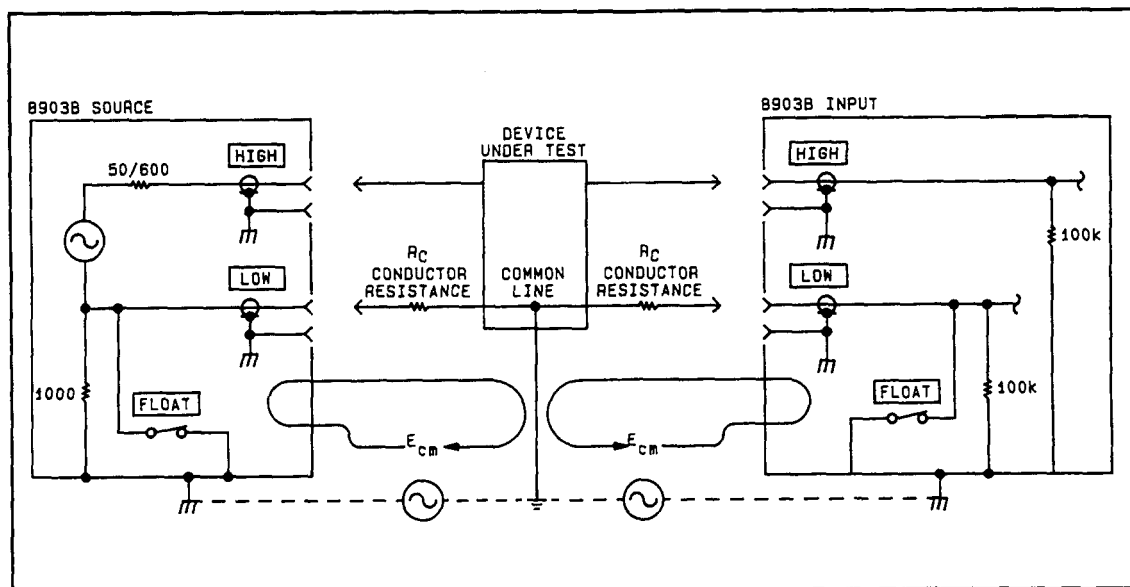

Effect of Multipoint Ground System (FLOAT Switch Closed)

One major source of error which must be considered when measuring low level ac signals or when making low distortion measurements is error introduced by ground loops. The previous illustration illustrates a typical measurement setup using the Audio Analyzer. In the figure the system common line is connected to chassis or earth ground at two separate points: the chassis of the Audio Analyzer and the common point of the device under test. Since two physically separate ground points are seldom at the same ground potential, current will flow in the system common line. Due to conductor resistance (RC) in the system common line, the current causes a voltage drop. This voltage drop (a common-mode voltage) sums with the signal under measurement and can cause erroneous readings. Grounding the system common line at a single point minimizes the effect of common mode voltages caused by ground loops. Floating the Audio Analyzer input and output circuitry isolates the LOW center conductor of the Audio Analyzer from chassis ground. Thus the Audio Analyzer input and output circuits are grounded only through the device under test. Note that the system common line is now grounded at a single point.

A simplified diagram of the source output circuit is shown below. Note that in the float mode, there is no ground present at the output (actually, the center conductor of the LOW terminal is connected to chassis ground through a 1K Ω resistor).

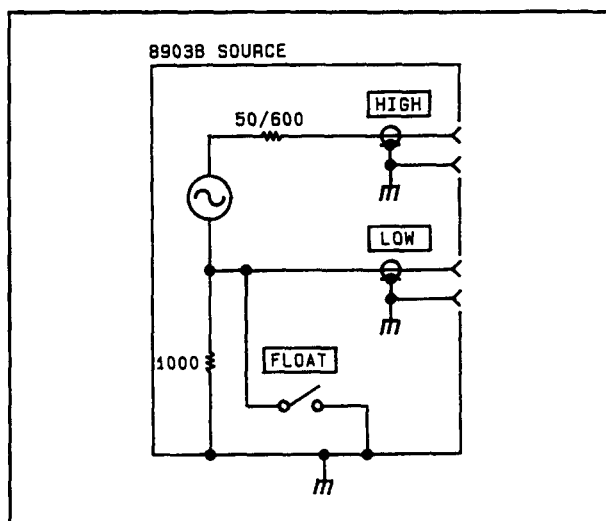

Simplified Schematic of the Audio Analyzer Source Output

In the float mode the output can be used as a summing circuit. An external source (either ac or dc) can be applied to either the HIGH or LOW connectors. The output signal is the sum of the internal source plus the external source. The OUTPUT LOW and HIGH connectors can be floated up to 10V peak.

CAUTION

Do not allow the voltage at the OUTPUT LOW or OUTPUT HIGH connector to be greater than +10V or less than -10V (ac + dc).

Frequency

DESCRIPTION

The Audio Analyzer provides a low-distortion sine wave output from 20 Hz to 100 kHz. The **FREQ** key along with numeric data and unit keys are used to program the frequency of the source. The **FREQ** key is also used to display the currently programmed frequency.

PROCEDURE

To set the source frequency, press the **FREQ** key and then the appropriate numeric data and unit keys. Once the **FREQ** key has been pressed, new data and unit entries can be made to select different frequencies until another source function key (for example, the **AMPTD** key) is pressed. To display the currently programmed source frequency press and hold the **FREQ** key.

EXAMPLE

To set the source frequency to 500 Hz.

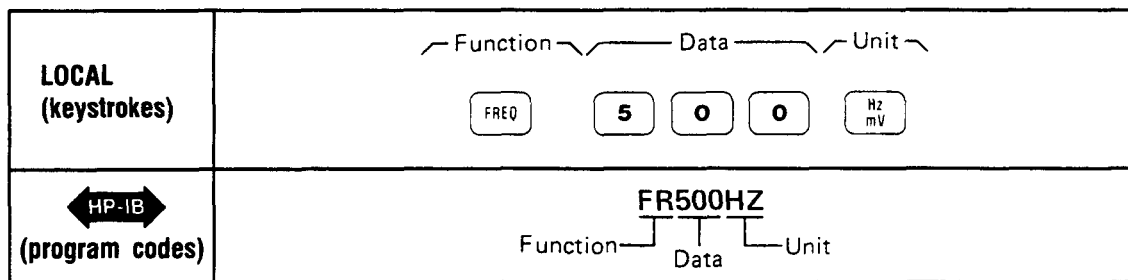

PROGRAM CODES



Keys	Program Code
FREQ	FR
Hz	HZ
kHz	KZ

INDICATIONS

When the **FREQ** key is pressed, the left display shows the currently set frequency setting. As the new frequency data is entered, it will appear on the left display. When the unit key is pressed, the left display returns to show the input signal frequency.

COMMENTS

When the **FREQ** key is pressed and held the left display shows the currently programmed frequency. It is important to realize the value shown in the left display is the programmed value which can differ from the actual frequency at the output. This difference is caused by the fact that the source is a programmable oscillator and not a synthesizer. However, the source frequency is within $\pm 0.3\%$ of the entered value. Also realize that the displayed count is the frequency of the input signal and is the same as the source frequency only if the source is the stimulus for the input.

For an alternate method of programming frequency with high rapidity (3 ms typical), see *Rapid Source*. For a method which permits a faster frequency counting over HP-IB, see *Rapid Frequency Count*.

RELATED SECTIONS

Amplitude
Increment
Rapid Frequency Count
Rapid Source

Hold Decimal Point (Special Function 4)

DESCRIPTION

The position of the decimal point in the right display can be held in a specific position by using Special Function 4.

PROCEDURE

To hold the decimal point in the right display to a specific position, key in the corresponding Special Function code then press the SPCL key.

Decimal Hold Position	Special Function Code	Program Code ↔ HP-IB ↔
Automatic Selection	4.0 SPCL	4.0SP
DDDD. V Range*	4.1 SPCL	4.1SP
DDD.D V Range	4.2 SPCL	4.2SP
DD.DD V Range	4.3 SPCL	4.3SP
D.DDD V Range	4.4 SPCL	4.4SP
0.DDDD V Range**	4.5 SPCL	4.5SP
DD.DD mV Range	4.6 SPCL	4.6SP
D.DDD mV Range	4.7 SPCL	4.7SP
0.DDDD mV Range**	4.8 SPCL	4.8SP

*The decimal point does not appear on the display. It is shown to establish the position it would appear in the numeric value of the readout.

**The zero does not appear on the display. It is shown to clarify the position of the decimal point.

EXAMPLE

To hold the decimal point after the first digit of a mV Range (D.DDD mV):

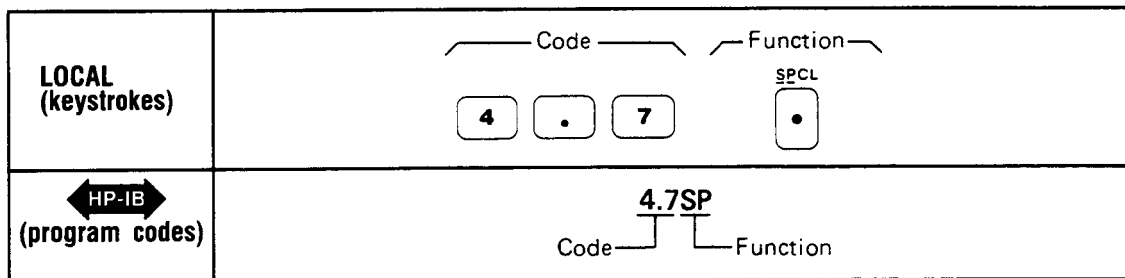

PROGRAM CODES

◀HP-IB▶ For HP-IB codes refer *Procedure* above.

INDICATIONS

As the numeric code is entered, both displays will blank, and the entered code will appear in the left display. When the SPCL key is pressed, the SPCL key LED will light (if it is not already on). If it is already on, it will remain on. The right display will show the amplitude with the decimal held in the position requested. The left display provides the normal information associated with the selected measurement mode.

COMMENTS

It is possible to use the Hold Decimal Point Special Function to set the display for a readout that exceeds the resolution of the instrument. For example, in the dc level measurement mode, 4.7 SPCL will set the display to a mV range. In this case, the three digits following the decimal point will always be zeros and are not significant digits in the amplitude readout.

RELATED SECTIONS

Automatic Operation
Special Functions

Hold Settings (Special Function 9)

DESCRIPTION

The Hold Settings Special Function is used to freeze the instrument in the presently selected settings for the input level ranges, the post-notch gain, the decimal point position, and the notch tuning.

PROCEDURE

To hold the presently selected settings for the functions above, press 9.0 then the SPCL key.

EXAMPLE

To hold the present settings of the specified functions:

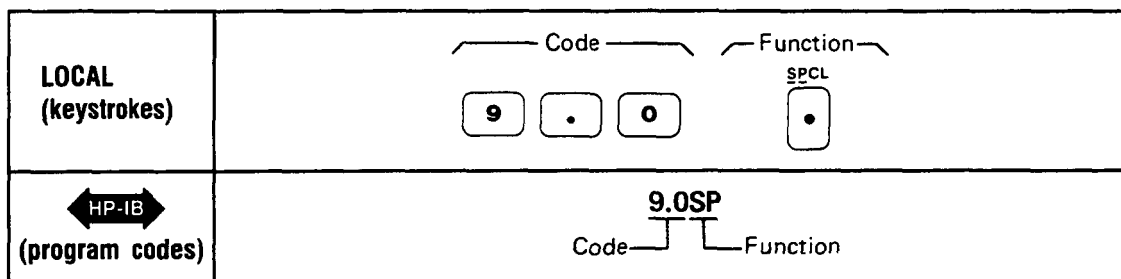

PROGRAM CODE

HP-IB For HP-IB code, refer to *Example* above.

INDICATIONS

As the numeric code is entered, both displays will blank, and the entered code will appear in the left display. When the SPCL key is pressed, the SPCL key LED will light if it is not already on. If it is already on, it will remain on. The displays will then show the normal readings for the currently selected measurement mode.

COMMENTS

Using Special Function 9 is equivalent to entering the following Special Functions from the keyboard:

- 1.N Input Level Range (Except DC Level)
- 2.N Input Level Range (DC Level Only)
- 3.N Post-Notch Gain
- 4.N Hold Decimal Point (Right Display Only)
- 6.1N Hold Notch Tuning

For Special Functions 1 through 4, N is set equal to the currently selected value that the instrument is using for that function. These values can be read by using the Special Special Display (refer to *Special Functions*).

Note that using the Hold Settings Special Function can cause inaccurate measurements under some circumstances.

Once settings have been held by the Hold Settings Special Function, one or more of them can be reset to their automatic modes by issuing the 0 suffix code of the corresponding Special Function. As an example, Hold Settings places the instrument in hold notch tuning mode. Use 6.0 SPCL to re-enter the automatic notch tuning mode.

RELATED SECTIONS

Automatic Operation
Special Functions

HP-IB Address (Special Function 21)

DESCRIPTION

The Audio Analyzer's present HP-IB address can be displayed by using Special Function 21. This display is in binary or decimal. When in binary (Special Function 21.0), the right display shows whether the instrument is set to talk only or listen only, and whether it is at present issuing a service request. The left display shows the address in binary. When in decimal (Special Function 21.1), the display is shown as "Addr= NN" (where NN is the HP-IB decimal address). The address set at the factory is 28 in decimal (11100 in binary). The HP-IB address in decimal can also be viewed by pressing the shift key and then the LCL key.

PROCEDURE

To display the HP-IB address, key in the appropriate Special Function code on the numeric keys, then press the SPCL key. To clear the display, press the CLEAR key. The instrument then reverts to the previous measurement mode.

A list of the Special Function codes is given below:

Display Format	Special Function Code	Program Code 
Binary	21.0 SPCL	21.0SP
Decimal	21.1 SPCL	21.1SP

A list of the allowable addresses for the Audio Analyzer is given below:

Allowable HP-IB Address Codes

Address Switches					Talk Address Character	Listen Address Character	Decimal Equivalent	Address Switches					Talk Address Character	Listen Address Character	Decimal Equivalent
A5	A4	A3	A2	A1				A5	A4	A3	A2	A1			
0	0	0	0	0	@	SP	0	1	0	0	0	P	0	16	
0	0	0	0	1	A	!	1	1	0	0	1	Q	1	17	
0	0	0	1	0	B	"	2	1	0	0	1	R	2	18	
0	0	0	1	1	C	#	3	1	0	0	1	S	3	19	
0	0	1	0	0	D	\$	4	1	0	1	0	T	4	20	
0	0	1	0	1	E	%	5	1	0	1	0	U	5	21	
0	0	1	1	0	F	&	6	1	0	1	1	V	6	22	
0	0	1	1	1	G	'	7	1	0	1	1	W	7	23	
0	1	0	0	0	H	(8	1	1	0	0	X	8	24	
0	1	0	0	1	I)	9	1	1	0	0	Y	9	25	
0	1	0	1	0	J	•	10	1	1	0	1	Z	:	26	
0	1	0	1	1	K	+	11	1	1	0	1	[;	27	
0	1	1	0	0	L	,	12	1	1	1	0	\	<	28	
0	1	1	0	1	M	-	13	1	1	1	0]	=	29	
0	1	1	1	0	N	.	14	1	1	1	1	(>	30	
0	1	1	1	1	O	/	15								

INDICATIONS

As the numeric code is entered, it will appear on the left display. When the SPCL key is pressed, the light within the key will turn on and all measurement key lights and annunciators will turn off. If the 21.0 Special Function was entered, the left display will show a binary number of the form AAAAA where AAAAA is the HP-IB address in binary. The right display will show a binary number of the form TLS where the T, L, and S have the meaning indicated in the table below.

	T	L	S
0	NOT TALK ONLY	NOT LISTEN ONLY	NOT REQUESTING SERVICE
1	TALK ONLY	LISTEN ONLY	REQUESTING SERVICE

If T and L are both 1, the instrument is set to talk only (talk overrides listen). If all the A digits are set to 1 and T is 1, the instrument will be in talk status only (that is, output the status byte only). (If all digits AAAAA.TL are 1 but S is 0, the Remote Interface board is not installed.) If the 21.1 Special Function was entered, the left display will show the statement "ADDR = " and the right display will show the decimal value of the instrument's HP-IB address (28 if it has not been changed).

EXAMPLES

To display the HP-IB address in binary and the status of the T, L, and S bits:

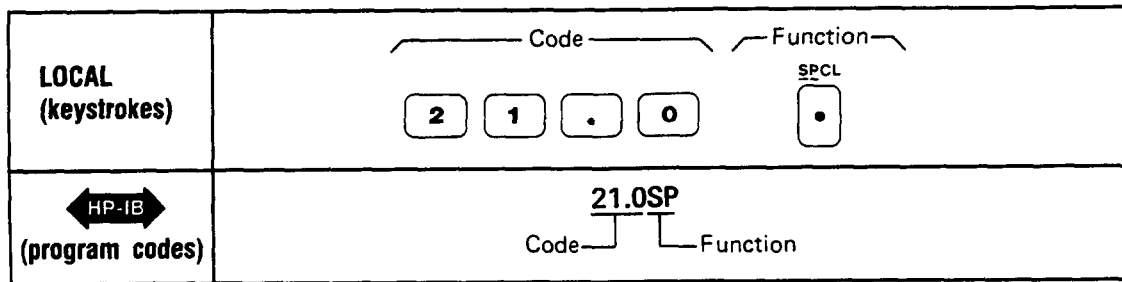

If the following is displayed:

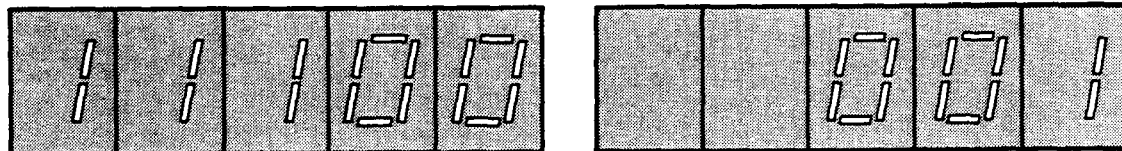

then the HP-IB address is 11100 in binary (28 in decimal). In ASCII, the talk address is \ , and the listen address is <. The instrument is not set to talk or listen only, but it is issuing a service request (setting the SRQ control line true).

To display the HP-IB address in decimal:

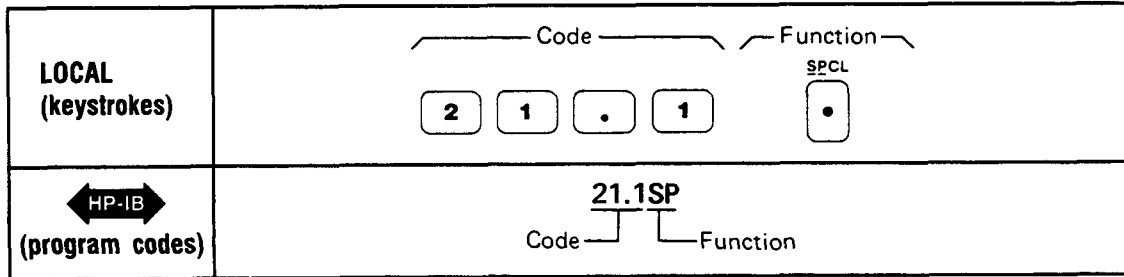

Assuming the same address, the following will be displayed:

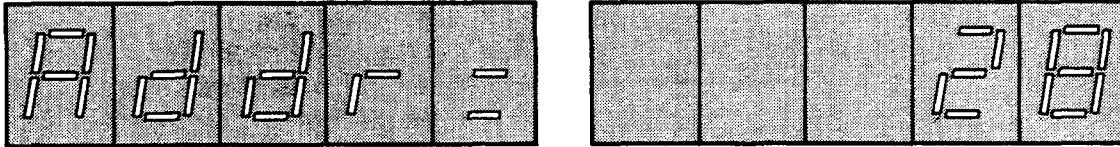

PROGRAM CODE

 For HP-IB codes refer to *Procedure* .

COMMENTS

The HP-IB address display is continuously updated. This makes setting the address easy since the result of changing a switch setting is immediately visible on the display. For information on setting the HP-IB address of the Audio Analyzer, refer to Section 2 of this manual. The factory-set address is, as shown in the examples, decimal 28. The T and L bits are set to 0. The S bit is 0 at instrument power up.

RELATED SECTIONS

- Special Functions
- Remote Operation, Hewlett-Packard Interface Bus

Increment

DESCRIPTION

The frequency and amplitude of the source can be incremented (or decremented) using the proper combination of the **FREQ**, **FREQ INCR**, **AMPTD**, **AMPTD INCR**, $\div 10$, $\times 10$ and **FREQ/AMPTD ADJUST** keys. These keys provide a convenient method of controlling the source when it is used in applications such as locating the 3 dB point of filters and amplifiers.

PROCEDURE

The general procedure to change the source parameters is to use either the **FREQ INCR** or **AMPTD INCR** key to establish which parameter is to be changed and the initial increment size. The **FREQ/AMPTD ADJUST** keys are then used to modify the source output.

EXAMPLES

To set the amplitude increment to 1.5V:

LOCAL (keystrokes)	
(program codes)	

To increment the currently programmed source amplitude value +1.5V:

LOCAL (keystrokes)	
(program codes)	

To divide the currently programmed amplitude increment by 10 (that is, to set the amplitude increment to 0.15V):

LOCAL (keystrokes)	
(program codes)	This function is not programmable.

NOTE

In the last two examples above, either the programmed amplitude or amplitude increment would be changed only if either the AMPTD or AMPTD INCR key was pressed last. If either the FREQ or FREQ INCR key had been pressed last, the programmed frequency or frequency increment would be changed. Note that when using HP-IB program codes, the UP or DN commands increment or decrement the parameter that was last implemented; for example, FN (or FR) or AN (or AP).

PROGRAM CODES



Parameter	Program Code
Frequency Increment	FN
Amplitude Increment	AN
↑ (step up)	UP
↓ (step down)	DN
Frequency Units (Hz, kHz)	HZ, KZ
Amplitude Units (V, mV, dB)	VL, MV, DB

INDICATIONS

The specific indications depend on the manner in which the keys are pressed. For example, momentarily pressing the FREQ INCR key will cause the currently programmed frequency increment to appear in the left display for approximately two seconds. Pressing and holding the FREQ INCR key down will cause the currently programmed frequency increment to remain displayed until the key is released. The AMPTD INCR key can be used in a similar manner to display the currently programmed value of the amplitude increment. When using the ↑ (step up) or ↓ (step down) keys, the parameter that is incremented depends upon which of the source parameter keys (that is, FREQ, FREQ INCR, AMPTD, or AMPTD INCR) was pressed last. Momentarily pressing ↑ causes the parameter to be incremented one step. The new value of the source parameter can be observed by pressing FREQ or AMPTD as appropriate. Remember that the programmed values for the source can differ from the displayed measurement values. Pressing and holding the ↑ or ↓ keys down causes the parameter to be stepped continuously. The effect of the change on the measurement results can be seen on the displays.

Pressing the ÷ or × 10 key modifies the currently programmed parameter that is active as indicated. Note that to repeat the division or multiplication of the parameter the key must be pressed again. Holding these keys down do not cause additional multiplication or division of the source parameter.

COMMENTS

Neither the ÷ or × 10 keys are HP-IB programmable.

Remember that all FREQ/AMPTD ADJUST key operations depend upon source parameter information previously input to the Audio Analyzer (for example, FREQ, AMPTD, etc.).

The amplitude can be incremented in either linear units (V or mV) or logarithmic units (dB) regardless of the units used to program the amplitude originally.

Incrementing frequency in relatively small steps may give unexpected results due to the tuning routine. The frequency may increment: not at all, more or less than requested, or even in the opposite direction. When a new frequency is entered, whether as an absolute frequency or as a frequency increment, the controller tunes the source until the frequency is within 0.2% of the entered input. The tuning routine is repeated for each new input. When within the 0.2% range of the new input, tuning ceases whether the entered increment has occurred or not.

RELATED SECTIONS

Amplitude
Frequency

Input Level Range (DC Level) (Special Function 2)

DESCRIPTION

In all measurement modes the input level range can be manually set by keyboard entry using the SPCL key. The following discussion describes this function for dc level mode only. Refer to *Input Level Range (Except DC Level)* for additional information. In the automatic operation mode, the input level range is determined by both the dc and ac (if there is one) level of the input signal.

PROCEDURE

To set the input level range to a selected range or to re-enter the automatic selection mode, key in the corresponding Special Function code, then press the SPCL key.

Input Level Range (Full Scale)	Input Attenuation	Special Function Code	Program Code ◀ HP-IB ▶
Automatic Selection	—	2.0 SPCL	2.0SP
300V range	40 dB	2.1 SPCL	2.1SP
64V range	24 dB	2.2 SPCL	2.2SP
16V range	12 dB	2.3 SPCL	2.3SP
4V range	0 dB	2.4 SPCL	2.4SP

EXAMPLE

To set the input level range to the 16V range:

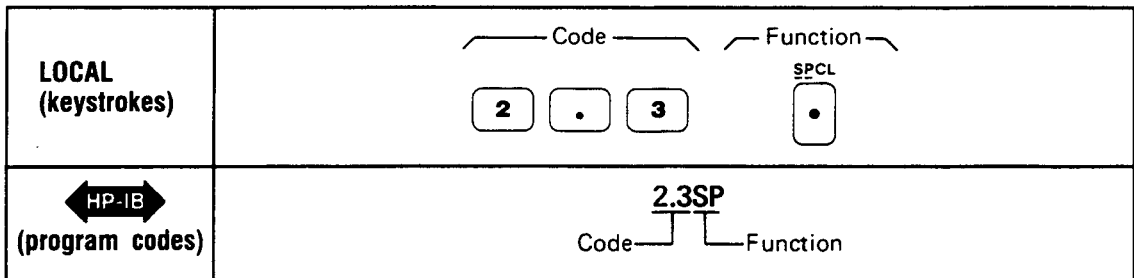

PROGRAM CODE

◀ HP-IB ▶ For HP-IB codes, refer to *Procedure* above.

INDICATIONS

As the numeric code is entered, it will appear on the left display. When the SPCL key is pressed, the left display blanks out. Note that for all measurement modes except dc level, the left display will return to show the input signal frequency after the SPCL key is pressed. Unless Special Function code 2.0 was entered, the light within the SPCL key will turn on (if not already on). If the light is already on, it will remain on.

COMMENTS

When the Audio Analyzer powers up or when AUTOMATIC OPERATION is selected, the input level range is placed in the automatic selection mode.

If the input level range is set such that the input signal level causes the input overload detector to trip, Error 30 will be displayed.

Manually selecting the gain of the input level circuitry can cause measurement error. Measurement accuracy is not specified whenever the gain of the input level circuitry is manually selected because the selected gain setting may be less than optimum. It is important to note that error messages indicating invalid measurements due to incorrect gain settings are not generated unless overload conditions occur. Automatic operation ensures accurate measurements for all combinations of input signals and measurement modes.

RELATED SECTIONS

Automatic Operation

DC Level

Input Level Range (Except DC Level)

Monitor

Special Functions

Input Level Range (Except DC Level) (Special Function 1)

DESCRIPTION

In all measurement modes the input level range can be manually set by keyboard entry using the SPCL key. The following discussion describes this function for all measurement modes except DC Level mode. Refer to *Input Level Range (DC Level)* for additional information. The input circuitry consists of a programmable attenuator and two programmable amplifiers. In automatic operation mode, the gain of the attenuator-amplifier section of the input is automatically set according to the level of the input signal.

PROCEDURE

To set the input level range to a selected range or to re-enter the automatic selection mode, key in the corresponding Special Function Code, then press the SPCL key.

Input Level Range (Full Scale)	Special Function Code	Program Code ↔ HP-IB ↔
Automatic Selection	1.0 SPCL	1.0SP
300V	1.1 SPCL	1.1SP
189V	1.2 SPCL	1.2SP
119V	1.3 SPCL	1.3SP
75.4V	1.4 SPCL	1.4SP
47.6V	1.5 SPCL	1.5SP
30.0V	1.6 SPCL	1.6SP
18.9V	1.7 SPCL	1.7SP
11.9V	1.8 SPCL	1.8SP
7.54V	1.9 SPCL	1.9SP
4.76V	1.10 SPCL	1.10SP
3.00V	1.11 SPCL	1.11SP
1.89V	1.12 SPCL	1.12SP
1.19V	1.13 SPCL	1.13SP
0.754V	1.14 SPCL	1.14SP
0.476V	1.15 SPCL	1.15SP
0.300V	1.16 SPCL	1.16SP
0.189V	1.17 SPCL	1.17SP
0.119V	1.18 SPCL	1.18SP
0.0754V	1.19 SPCL	1.19SP

EXAMPLE

To set the input level range to the 30.0V range:

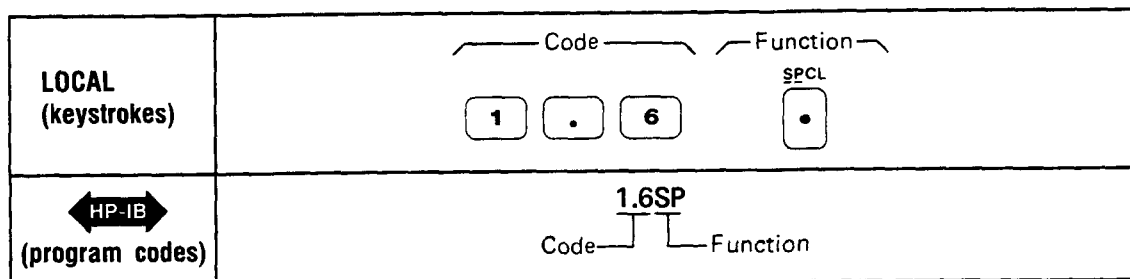

PROGRAM CODE

◀ HP-IB ▶ For HB-IB codes, refer to *Procedure* above.

INDICATIONS

As the numeric code is entered, it will appear on the left display. When the SPCL key is pressed, the display returns to show the input signal frequency. Unless Special Function code 1.0 was entered, the light within the SPCL key will turn on (if not already on). If the light is already on, it will remain on.

COMMENTS

When the Audio Analyzer is first powered up or when AUTOMATIC OPERATION is selected, the input level range is placed in the automatic selection mode. If the input level range is set such that the input signal level creates an overrange condition, an error message will be displayed. The error message generated depends on instrument settings and the input signal level. For example, if the input level range is set such that the input signal level causes the input overload detector to trip, Error 30 will be displayed. For a complete listing of the error messages, refer to *Error Message Summary*.

Manually selecting the gain of the input level circuitry can cause measurement error. Measurement accuracy is not specified whenever the gain of the input level circuitry is manually selected because the selected gain setting may be less than optimum. It is important to note that error messages indicating invalid measurements due to incorrect gain settings are not generated unless overload conditions occur. Automatic operation ensures accurate measurements for all combination of input signals and measurement modes.

RELATED SECTIONS

- AC Level
- Automatic Operation
- Input Level Range (DC Level)
- Monitor
- Special Functions

Monitor

DESCRIPTION

The rear-panel MONITOR output provides a means of monitoring the ac signal into the output rms detector. The auto-ranging MONITOR output level is normally a 0.3 to 3 V_{rms} signal which is proportional to the input signal. In ac level and dc level the MONITOR output provides a scaled representation of the ac component of the input signal. In SINAD, distortion, and distortion level the MONITOR output provides a scaled representation of the input signal with the fundamental removed. The output is dc coupled with a 600Ω output impedance and a BNC female connector. The MONITOR output can be used to drive other test instruments, such as an oscilloscope, wave analyzer, or spectrum analyzer for further analysis.

BLOCK DIAGRAM

A simplified block diagram of the Audio Analyzer measurement circuits illustrating the relationships between the MONITOR output and the other circuit blocks is shown below. The MONITOR output block diagram illustrates the signal path from the INPUT to the MONITOR output. The diagram is that of a programmable gain amplifier with a tunable notch filter. In ac level, dc level, and signal-to-noise the notch filter is bypassed. In SINAD, distortion, and distortion level the notch filter is switched into the signal path, removing the fundamental frequency.

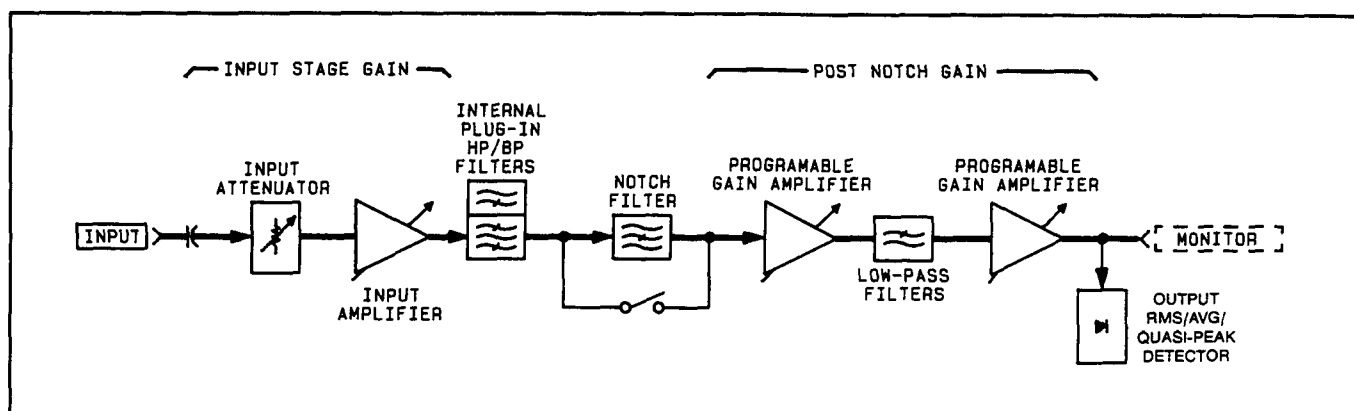

Monitor Output Block Diagram

COMMENTS

The MONITOR output gain and sensitivity (that is, the net signal gain from the INPUT to the MONITOR output) are dependent on the input stage gain and the post-notch gain. Both the input stage gain and the post-notch gain can be determined by viewing the Special Special Display (refer to *Special Functions*).

The input stage gain and post-notch gain for various instrument settings are listed in the following tables.

INPUT STAGE GAIN (Except dc)			
Special Display 1.NN	Input Level Range	Gain	
		Log (dB)	Linear
1.1	300V	-40	0.0100
1.2	189V	-36	0.0158
1.3	119V	-32	0.0251
1.4	75.4V	-28	0.0398
1.5	47.6V	-24	0.0631
1.6	30.0V	-20	0.1000
1.7	18.9V	-16	0.1585
1.8	11.9V	-12	0.2512
1.9	7.54V	-8	0.3981
1.10	4.76V	-4	0.6310
1.11	3.00V	0	1.00
1.12	1.89V	+4	1.58
1.13	1.19V	+8	2.51
1.14	0.754V	+12	3.98
1.15	0.476V	+16	6.31
1.16	0.300V	+20	10.00
1.17	0.189V	+24	15.85
1.18	0.119V	+28	25.12
1.19	0.0754V	+32	39.81

POST-NOTCH GAIN		
Special Display 3.N	Gain	
	Log (dB)	Linear
3.1	0	1
3.2	+20	10
3.3	+40	100
3.4	+60	1000

The measurement system net gain equals the combined gain of the two stages. To calculate the net gain use the following formulas:

$$\text{Net Gain (LOG)} = \text{Input Stage Gain (LOG)} + \text{Post-Notch Gain (LOG)}$$

or

$$\text{Net Gain (LIN)} = \text{Input Stage Gain (LIN)} \times \text{Post-Notch Gain (LIN)}$$

In ac level the MONITOR output is a scaled replica of the input signal. The MONITOR output level is calculated as:

$$V_{\text{out}} = V_{\text{in}} \times \text{Net Gain}$$

where V_{in} is the input signal level and the linear net gain is used.

In SINAD, distortion, and distortion level the fundamental frequency is removed (suppressed) by more than 80 dB. The output after the notch filter includes all harmonics of the fundamental plus any noise, hum, and other spurious signals that may be present. These signal impurities are amplified and are available at the MONITOR for further analysis.

The following equations express the MONITOR output level as a function of the parameter being measured (the displayed reading). (Use linear Net Gain.) For distortion:

$$V_{out} = \frac{\text{Displayed Reading (in \%)} \times V_{in} \times \text{Net Gain}}{100}$$

or

$$V_{out} = 10^{\text{Displayed Reading (in dB)}/20} \times V_{in} \times \text{Net Gain}$$

For distortion level:

$$V_{out} = \text{Displayed Reading (in volts)} \times \text{Net Gain}$$

or

$$V_{out} = 10^{\text{Displayed Reading (in dBm)}/20} \times \text{Net Gain}$$

For SINAD:

$$V_{out} = \frac{100}{\text{Displayed Reading (in \%)}} \times V_{in} \times \text{Net Gain} \quad V_{out} = \text{Displayed Reading (in \%)}$$

or

$$V_{out} = 10^{-|\text{Displayed Reading (in dB)}|/20} \times V_{in} \times \text{Net Gain}$$

In the above equations V_{out} is the MONITOR output level as measured with a true rms voltmeter and V_{in} is the input signal level.

In the SIG/NOISE measurement mode the source is turned on and off. Therefore the signal level at the MONITOR output is constantly alternating.

The MONITOR output does not respond to dc signals presented at the INPUT. In the dc level measurement mode only the ac components of the input signal are presented at the MONITOR output.

RELATED SECTIONS

- AC Level
- DC Level
- Distortion
- Distortion Level
- Input Level Range (DC Level)
- Input Level Range (Except DC Level)
- Signal-to-Noise
- SINAD
- Special Functions

Notch Tune (Special Function 6)

DESCRIPTION

In distortion and distortion level modes, the Audio Analyzer automatically tunes the notch filter to the input frequency. In the SINAD mode, the notch filter is tuned to the frequency of the internal source. However, by means of keyboard entry using the SPCL key, the notch filter can be held to the current notch filter frequency setting.

PROCEDURE

To freeze the notch filter enter Special Function code 6.1, then press the SPCL key. To return to the automatic tuning mode press the AUTOMATIC OPERATION key or key in the Special Function code 6.0, then press the SPCL key.

Notch Tune	Special Function Code	Program Code ↔ HP-IB ↔
Automatic Notch Tuning	6.0SPCL	6.0SP or N0
Hold Notch Tuning	6.1SPCL	6.1SP or N1

EXAMPLE

To freeze the notch filter:

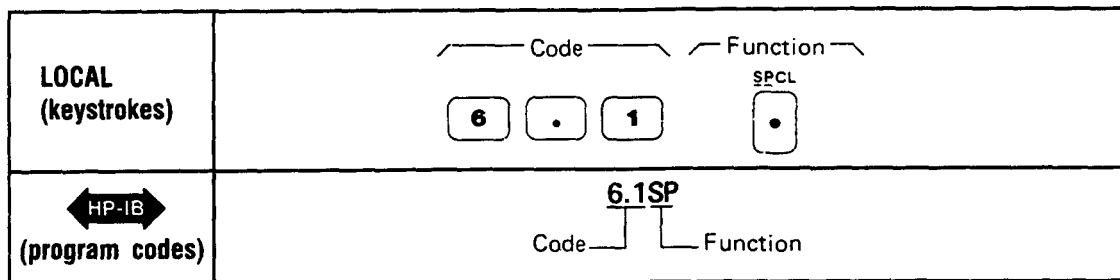

PROGRAM CODE

↔ HP-IB ↔ The above procedure gives the HP-IB codes for special functions 6.0 and 6.1. Notch Tuning may also be controlled over HP-IB with the commands N0 and N1.

INDICATIONS

As the numeric code is entered, it will appear on the left display. When the SPCL key is pressed, the display returns to show the input signal frequency. When Special Function code 6.1 is entered and the SPCL key is pressed, the LED within the SPCL key will turn on. The LED will not turn on for Special Function code 6.0. When the HP-IB codes N0 or N1 are used, there is no numeric code shown in the left display.

COMMENTS

When the Audio Analyzer first powers up or when AUTOMATIC OPERATION is selected, the Audio Analyzer is placed in the automatic notch tuning mode.

In the automatic tuning mode the Audio Analyzer counts the frequency of the input signal, then coarsely tunes the notch filter to that frequency. The notch filter is then fine tuned via circuitry internal to the notch filter. In the hold tune mode, the notch filter is no longer coarsely tuned, however the fine tune circuitry still remains operational. Thus the notch filter still automatically tunes, but now over a limited range. In the hold tuning mode the tuning or nulling range of the notch filter is approximately 5% of the frequency of the original notch filter setting.

RELATED SECTIONS

Automatic Operation

Distortion

Distortion Level

SINAD

Special Functions

Output Impedance

DESCRIPTION

The Audio Analyzer source has two selectable output impedances: 50Ω or 600Ω. This feature gives the instrument greater flexibility in matching 50Ω or 600Ω loads when making measurements. The Audio Analyzer Source is set to 600Ω Impedance at power up.

PROCEDURE

To select 50Ω impedance, enter in Special Function code 47.1, then press the SPCL key. To return the Source to 600Ω impedance enter in Special Function code 47.0 and press the SPCL key, or press the AUTOMATIC OPERATION key.

EXAMPLE

To select 50Ω impedance:

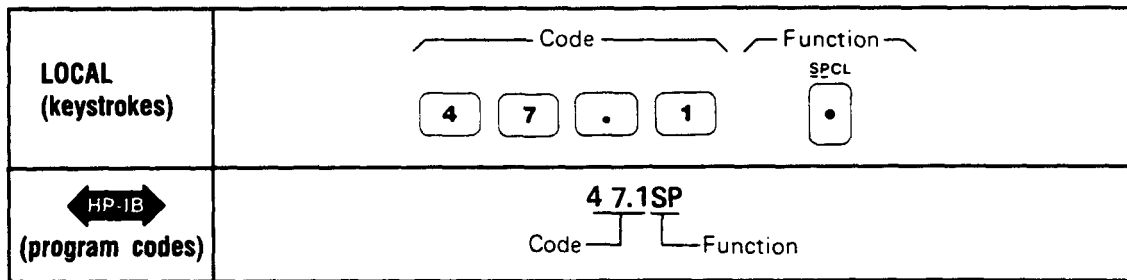

PROGRAM CODE

HP-IB The above procedure gives the HP-IB codes for special functions 47.0 and 47.1. Source Output Impedance may also be controlled over HP-IB with these same special functions: 47.0SP for 600Ω impedance, and 47.1SP for 50Ω impedance.

INDICATIONS

- The Impedance lamp will be on when the Source is set to 50Ω.
- The Impedance lamp will be off when the Source is set to 600Ω.

COMMENTS

The most common line impedance used for RF applications is 50Ω. With 50Ω line impedance you get higher short-circuit current (for a constant voltage), and ten times the frequency response over a given length of cable than 600Ω impedance. For audio applications, 600Ω impedance is commonly used.

The following illustrations show the maximum power the instrument can deliver into various loads using the source output impedance feature.

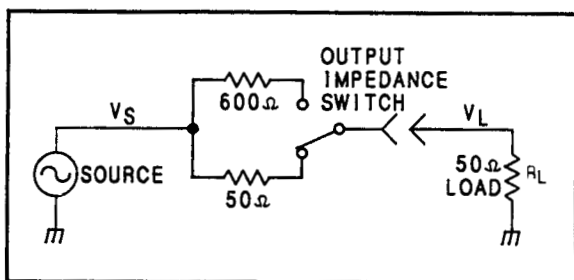

$$V_s = 6V \text{ (maximum)}$$

$$V_L = \frac{50\Omega}{50\Omega + 50\Omega} \cdot V_s$$

$$V_L = \frac{1}{2} \cdot V_s$$

$$V_L = 3V$$

$$P_{dBm_{LOAD}} = 10 \log \frac{P_L}{1 \text{ mW}} = 10 \log \frac{V_L^2 \div R_L}{1 \text{ mW}}$$

$$P_{dBm_{50\Omega}} = 10 \log \frac{(3)^2 \div 50}{1 \text{ mW}}$$

$$P_{dBm_{50\Omega}} = +22.5 \text{ dBm}$$

Maximum Power Output into a 50Ω Load at 50Ω Output Impedance

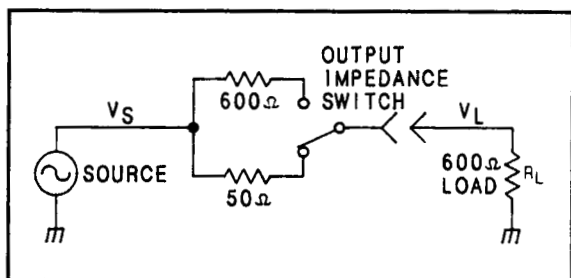

$$V_s = 6V \text{ (maximum)}$$

$$V_L = \frac{600\Omega}{50\Omega + 600\Omega} \cdot V_s$$

$$V_L = 0.923 \cdot V_s$$

$$V_L = 5.54V$$

$$P_{dBm_{600\Omega}} = 10 \log \frac{(5.54)^2 \div 600}{1 \text{ mW}}$$

$$P_{dBm_{600\Omega}} = +17 \text{ dBm}$$

Power Output into a 600Ω Load at 50Ω Output Impedance

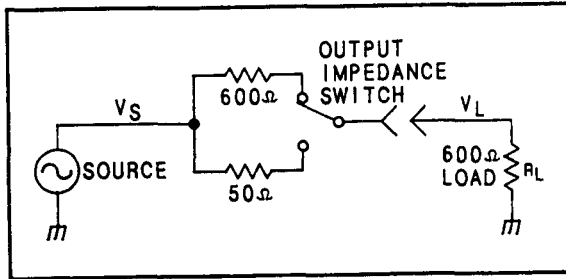

$$V_S = 6V \text{ (maximum)}$$

$$V_L = \frac{600\Omega}{600\Omega + 600\Omega} \cdot V_S$$

$$V_L = \frac{1}{2} \cdot V_S$$

$$V_L = 3V$$

$$P_{dBm_{600\Omega}} = 10 \log \frac{(3)^2 \div 600}{1 \text{ mW}}$$

$$P_{dBm_{600\Omega}} = +11.7 \text{ dBm}$$

Maximum power Output into a 600Ω Load at 600Ω Output Impedance

RELATED SECTIONS

None

Plot Limit

DESCRIPTION

The PLOT LIMIT, UPPER LIMIT, LOWER LIMIT, and the numeric data keys are used to program the upper and lower plot limits. The upper and lower plot limits correspond to the respective upper and lower scaling points of an X-Y plot. For more information on X-Y plots, refer to *X-Y Recording*. The Y-axis scaling is determined by the displayed measurement unit in the right display and the programmed upper and lower plot limit. The PLOT LIMIT key can be also used to display the currently programmed upper and lower plot limits.

PROCEDURE

To enter new plot limits, first press the PLOT LIMIT key to initiate entries. To enter an upper plot limit, press the appropriate numeric data keys, then the UPPER LIMIT key. Similarly, to enter a lower plot limit press the appropriate numeric data keys, then the LOWER LIMIT key. Once the PLOT LIMIT key has been pressed new plot limits can be successively entered until another source function key (for example, **FREQ** key) is pressed. To display the currently programmed plot limits press and hold the PLOT LIMIT key.

EXAMPLE

To enter an upper limit of 20 and a lower plot limit of -10:

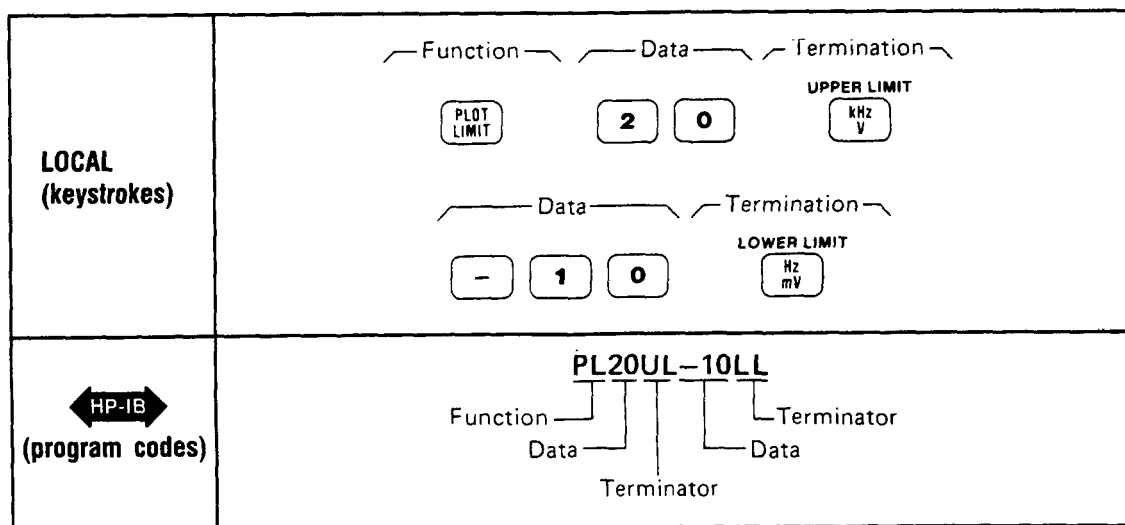

PROGRAM CODE



Key	Program Code ← HP-IB →
PLOT LIMIT	PL
UPPER LIMIT	UL
LOWER LIMIT	LL

INDICATIONS

When the PLOT LIMIT key is pressed, both displays will show the currently programmed plot limits. The upper limit appears on the right display and the lower limit appears on the left display. As a new upper or lower plot limit is entered, it will appear on the left display. When the UPPER LIMIT or LOWER LIMIT key is pressed, the left display returns to show the input signal frequency and the right display returns to show the measurement previously selected.

COMMENTS

The Audio Analyzer powers up with an upper and lower plot limit of 100 and -100 respectively.

The plot limit values can range from -1099 to 1099 in steps of 0.001. The values entered for the upper and lower plot limits are dimensionless. The plot limit units are the same as the right display measurement unit. For example, if an upper plot limit of 20 and a lower plot limit of -10 are entered and the measurement result is displayed in dB, the upper plot limit would correspond to 20 dB and the lower plot limit would correspond to -10 dB. If the measurement result had been displayed in % instead of dB, the upper plot limit would have corresponded to 20% while the lower plot limit would have corresponded to -10%. The plot limit units can be any of the following fundamental units: V, dB, dBm, and %. Note that mV cannot be used as a plot limit unit.

If the upper and lower plot limits are identical and the SWEEP key is pressed, Error 25 will be displayed. If plot limits are entered whereby the lower limit is greater than the upper limit, no error code is displayed. In this case, the Y-axis output ranges from approximately 10 Vdc for the lower plot limit value to 0 Vdc for the upper plot limit value, and the X-Y plot obtained is simply inverted. For example, if an upper plot limit of -10 and a lower plot limit of 20 are entered, and the measurement result is displayed in dB, the upper plot limit would correspond to -10 dB, and the lower plot limit would correspond to 20 dB.

RELATED SECTIONS

RATIO and LOG/LIN
X-Y Recording

Post-Notch Detector Filtering (Except SINAD) (Special Function 5)

DESCRIPTION

The Audio Analyzer normally makes audio measurements using a fast-responding detector. By means of keyboard entry using the SPCL key, additional low-pass filtering can be added after the post-notch detector. The additional low-pass filtering (slow detector) is useful in stabilizing measurements on unstable or noisy signals or whenever display jitter is considered excessive.

PROCEDURE

To change the Audio Analyzer post-notch filtering response from fast to slow or vice versa, enter the corresponding Special Function code, then press the SPCL key.

Post-Notch Detector Response	Special Function Code	Program Code
Fast RMS Detector	5.0 SPCL	5.0SP
Slow RMS Detector	5.1 SPCL	5.1SP
Fast AVG Detector	5.2 SPCL	5.2SP
Slow AVG Detector	5.3 SPCL	5.3SP

EXAMPLE

To enter a slow rms detector response mode:

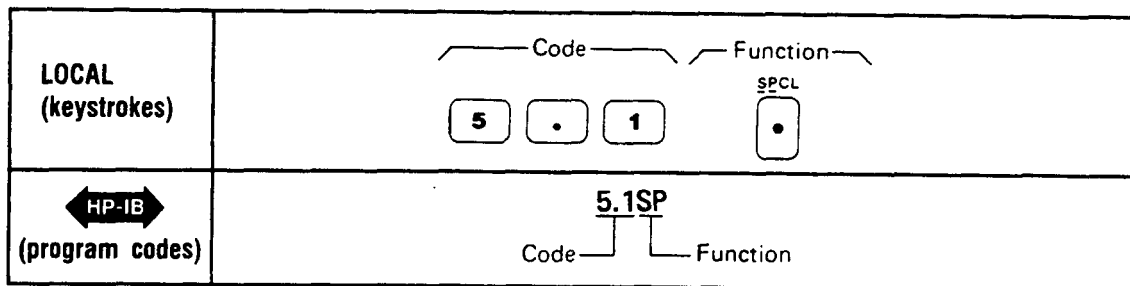

PROGRAM CODE

HP-IB For HP-IB codes, refer to the *Procedure* above.

INDICATIONS

As the numeric code is entered, it will appear on the left display. When the SPCL key is pressed, the display returns to show the input signal frequency. When Special Function code 5.1, 5.2, or 5.3 is entered and the SPCL key is pressed, the LED within the SPCL key will turn on (if not already on). If the light is already on, it will remain on. The LED will not turn on if Special Function code 5.0 is entered. The LED will turn off when both 5.0 SPCL and 47.0 SPCL are entered.

COMMENTS

When the Audio Analyzer is first turned on or when AUTOMATIC OPERATION is selected, the fast rms detector is selected.

In SINAD, additional low-pass filtering is always used. Fast detection (either rms or average) cannot be selected by means of keyboard entry using the SPCL key when in SINAD. Slow detection can be used when in SINAD.

RELATED SECTIONS

Automatic Operation
Special Functions

Post-Notch Gain (Special Function 3)

DESCRIPTION

The overall stage gain of the post-notch circuit can be manually set by keyboard entry using the SPCL key. The gain is selectable from 0 dB to 60 dB in 20 dB steps. In automatic operation mode, the instrument will automatically select the optimum post-notch gain.

PROCEDURE

To manually set the gain of the post-notch circuit or to re-enter the automatic selection mode, key in the corresponding Special Function code, then press the SPCL key.

Post-Notch Gain	Special Function Code	Program Code ↔ HP-IB ↔
Automatic Selection	3.0 SPCL	3.0SP
0 dB gain	3.1 SPCL	3.1SP
20 dB gain	3.2 SPCL	3.2SP
40 dB gain	3.3 SPCL	3.3SP
60 dB gain	3.4 SPCL	3.4SP

EXAMPLE

To set the post-notch gain to 40 dB:

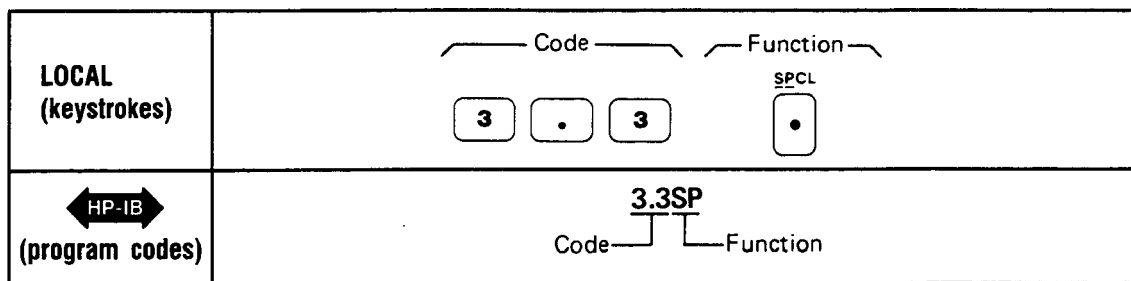

PROGRAM CODE

↔ HP-IB ↔ For HP-IB codes, refer to *Procedure* above.

INDICATIONS

As the numeric code is entered, it will appear on the left display. When the SPCL key is pressed, the display returns to show the input signal frequency. Unless Special Function code 3.0 was entered, the light within the SPCL key will turn on (if not already on). If the light is already on, it will remain on.

COMMENTS

When the Audio Analyzer is first powered up or when AUTOMATIC OPERATION is selected, the Audio Analyzer is placed in the automatic selection mode.

If the post-notch gain is set such that the input signal level causes the post-notch circuitry to be overdriven, four dashes will be displayed on the right display. If this overload condition is not corrected within nine measurement cycles, Error 31 will be displayed.

Manually selecting the gain of the post-notch circuit can cause measurement error. Measurement accuracy is not specified whenever the gain of the post-notch circuitry is manually selected because the selected gain setting may be less than optimum. It is important to note that error messages indicating invalid measurements due to incorrect gain settings are not generated unless overload conditions occur. Automatic operation ensures accurate measurements for all combination of input signals and measurement modes.

RELATED SECTIONS

Automatic Operation
Special Functions
Monitor

Rapid Frequency Count

DESCRIPTION

Rapid Frequency Count mode allows a remote controller to partially bypass the Audio Analyzer's own internal controller. The advantage is that frequency count measurements can be obtained from the Audio Analyzer much more quickly. The data obtained, however, is in a packed binary form and thus requires additional processing to produce the final results in hertz. Once the Rapid Frequency Count mode is entered, data will be placed on the bus in four-byte sequences until the mode is terminated. Rapid Frequency Count mode is terminated whenever the Audio Analyzer receives a bus command or whenever it is sent new programming data.

PROCEDURE

To use the Rapid Frequency Count mode the remote controller must be able to read the four-byte compacted frequency data using a binary specifier. First, place the Audio Analyzer into the ac level measurement mode, set it to measure the input signal (that is, the signal before the notch filter), and to trigger with settling. The HP-IB codes for this configuration are M146.1SPT3. Next, issue the HP-IB code for Rapid Frequency Count (RF) and then read the frequency data from the Audio Analyzer. The Audio Analyzer does not send carriage return, line feed, or any other characters as delimiters.

The frequency data will be in the form shown below:

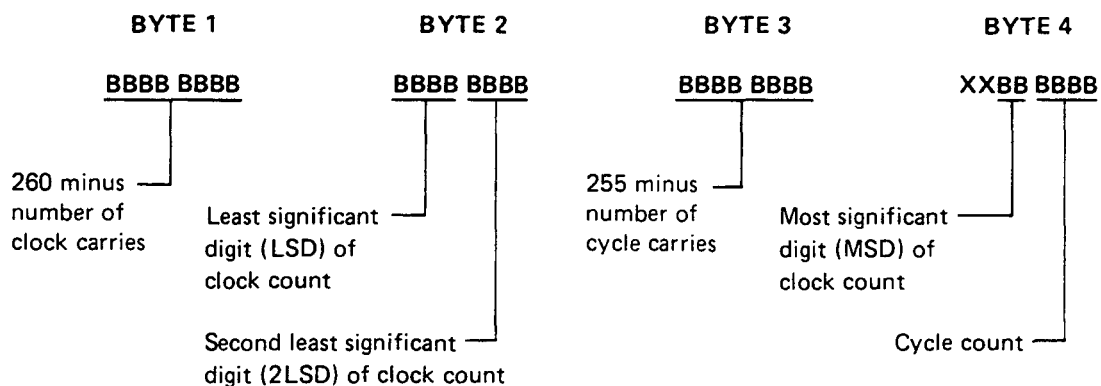

To obtain the frequency, compute:

$$\text{Total clock counts} = \text{LSD} + 16(2\text{LSD}) + 256(\text{MSD}) + 1024(260 - \text{BYTE 1})$$

$$\text{Total cycle counts} = \text{Cycle count} + 16(255 - \text{BYTE 3})$$

$$\text{Frequency} = \frac{\text{Total cycle counts}}{\text{Total Clock Counts}} \times (2 \times 10^6)$$

Where:

LSD = Least significant digit of clock count

2LSD = Second least significant digit of clock count

MSD = Most significant digit of clock count.

Using a BASIC controller such as the Hewlett-Packard Model 85B Desktop Controller, the computation is set up in seven steps as shown below:

```

10 OUTPUT 728 USING 'K' ; '46.1SPT3,RF'
20 ENTER 728 USING '#,B' ; A,B,C,D
30 T = IP(B/16) + 16*BINAND(B,15) + 16*BINAND(D,48) + 1024*(260-A)
40 E = BINAND(D,15) + 16*(255-C)
50 F = IP(E/T*200000000)/100
60 DISP F
70 END

```

Explanation:

Line 10: Places the Audio Analyzer in the Rapid Count Mode ("46.1SPT3" sets up the analyzer for transient free operation).

Line 20: Enter the four rapid count bytes using the Binary format "#,B".

Line 30: Calculate T = total clock counts by bit manipulation and proper weighting.

Line 40: Calculate E = total cycle counts by bit manipulation and proper weighting.

Line 50: Calculate the frequency $F = (\text{total cycle count}/\text{total clock count}) \times (2 \times 10^6)$. Note that the value is multiplied by 100 to round the integer part and then divide by 100 to round the answer to 2 digits to the right of the decimal.

Line 60: Displays the frequency count result.

Line 70: Terminates the program.

Using a HPL controller such as the Hewlett-Packard Model 9825A Desktop Controller, the computation is set up in seven steps as shown below:

```

0: wrt 728, 'RF'
1: fmt, z, 4b
2: red 728, r1, r2, r3, r4
3: shf (r2, 4) + 16 (band (r2, 15) + band (r4, 28)) + 1024 (260 -r1) → r5
4: band (r4, 15) + 16 (255 -r3) → r6
5: 2e6r6/r5 → B
6: dsp B
7: end

```

Explanation:

Line 0: Place the Audio Analyzer in the Rapid Frequency Count mode.

Lines 1,2: Establish a format suitable for reading four binary bytes from the Audio Analyzer. Take the readings and store the value in four "r" variables. The value stored is the decimal equivalent of the binary word.

Line 3: Shift various bytes around and weight their value by the proper amount (in accordance with the routine given) to obtain the number of Audio Analyzer clock counts. Assign that value to variable "r5".

Line 4: Position bits correctly and weight appropriately to determine the number of cycle counts. Assign that value to variable "r6".

Line 5: Since the Audio Analyzer uses a reciprocal counter, the frequency of the input signal equals the number of input cycles (r6) divided by total time elapsed during these input cycles. The denominator is determined by counting the number of 2 MHz clock counts that occur during these input cycles and multiplying by the frequency of the clock (2 MHz). Total time equals number of clock counts divided by 2×10^6 .

$$\text{Total time (seconds)} = \frac{r5}{2 \times 10^6}$$

Thus:

$$\text{Input frequency (Hz)} = \frac{r6}{r5/2 \times 10^6} = \left(\frac{r6}{r5}\right) \times 2 \times 10^6$$

Line 6: Displays the frequency count result.

Line 7: Terminates the program.

PROGRAM CODE

 Program Code RF is the HP-IB code that initiates the Rapid Frequency Count mode.

INDICATIONS

When in Rapid Frequency Count mode, the Audio Analyzer's left display will show " — — — — —".

COMMENTS

The major advantage of Rapid Frequency Count mode is that data can be taken in rapid sequence and stored in an array in the computing controller. Then, at a later time when operations do not require immediate controller attention, the packed binary data can be converted into decimal frequency data. This way the time required for the Audio Analyzer to process the data into decimal frequency is eliminated. This greatly increases its measurement speed for measuring tone burst sequences.

RELATED SECTION

Rapid Source

Rapid Source

DESCRIPTION

Rapid Source mode allows a remote controller to partially bypass the Audio Analyzer's internal controller and tune the source portion of the instrument directly. The main advantage of this function is that by directly controlling the source, the Audio Analyzer's count-and-tune routine is bypassed and the need to convert decimal frequency information to the binary control data is eliminated. Typically, in this mode, the source can be programmed in less than three milliseconds. This makes generation of tone burst sequences practical.

PROCEDURE

To use the Rapid Source mode, two procedures must be performed. First, the packed binary tuning data must be obtained from the Audio Analyzer. Second, the instrument is placed into the Rapid Source mode and the five-byte binary tuning data is sent.

NOTE

When using the 55, 56, and 57 Special Functions, entering 55. SPCL, 56. SPCL, and 57. SPCL will give a readback of the present instrument settings. Entering 55.0 SPCL, 56.0 SPCL, and 57.0 SPCL will actually set the instrument settings to 0. This is a different default condition than is used with most Special Functions. Normally, omitting the 0 following the decimal has the same result as entering it. However, in the case of 55, 56, and 57 Special Functions, two different functions are performed. For additional information refer to the Service Special Functions in Section 8.

Acquiring the Tuning Data. Three values must be acquired from the Audio Analyzer: coarse tune data, fine tune data, and range data. To do this, first tune the Audio Analyzer to the desired frequency either manually or via the HP-IB. Then use the 55., 56., and 57. Special Functions to determine the range, coarse tune, and fine tune values respectively. Then build the five-byte sequence as follows:

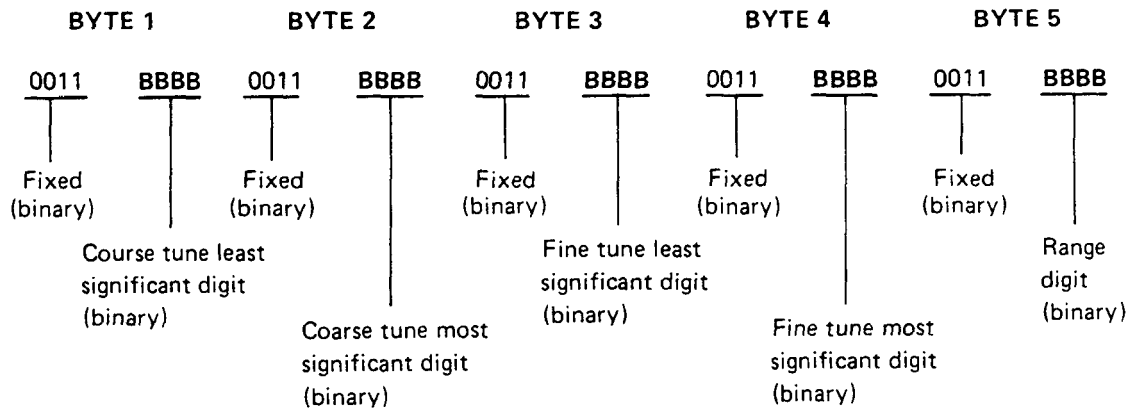

As shown above, the upper four bits of each byte sent to the Audio Analyzer are always 0011. This places the resulting codes in the ASCII range of "0" (decimal 48) to "?" (decimal 63). To build the five-byte sequence, convert the decimal data obtained via the Special Functions into binary. In the case of the coarse and fine tune data, split the eight bits into two groups of four (representing the most and least significant digits). Insert each four-bit packet into its respective byte.

NOTE

The binary data obtained to tune the Audio Analyzer to a particular frequency may vary both with warm up and between instruments. Therefore, when maximum accuracy is desired, it is recommended that this data be reacquired approximately each hour or each time a different Audio Analyzer is used.

Entering and Terminating Rapid Source Mode. Rapid Source mode is entered immediately when the Audio Analyzer receives the HP-IB code RS. Rapid Source mode is terminated whenever any Audio Analyzer front-panel key is pressed or whenever the Attention bus control line is set true (that is, whenever any bus command or talk or listen address is placed onto the bus).

NOTE

Once the Rapid Source code has been issued to the Audio Analyzer, no bus activity should occur until the tuning is completed. Bus activity may cause the Rapid Source mode to be prematurely terminated.

EXAMPLE

To obtain the tuning data to tune the Audio Analyzer to 1000 Hz, first tune the Audio Analyzer by conventional techniques:

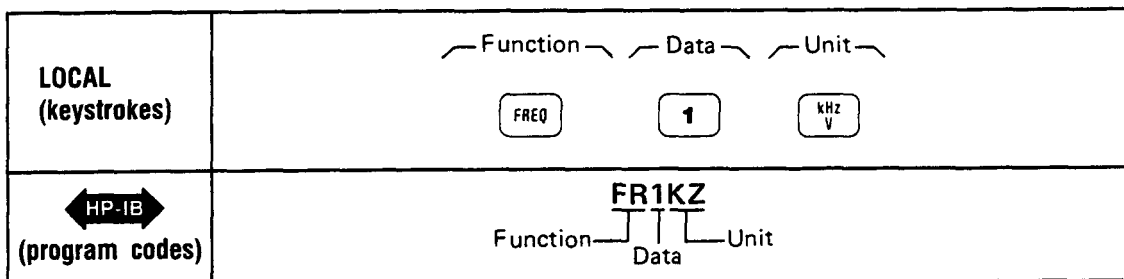

Now use the Special Functions to obtain the tuning data. First get the range data:

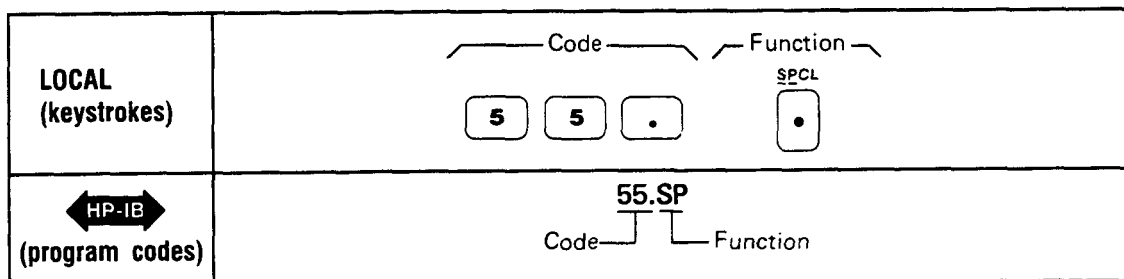

For example, the right display on the Audio Analyzer shows a 1 (decimal) which equals 0001 in binary.

Now obtain the coarse tune data:

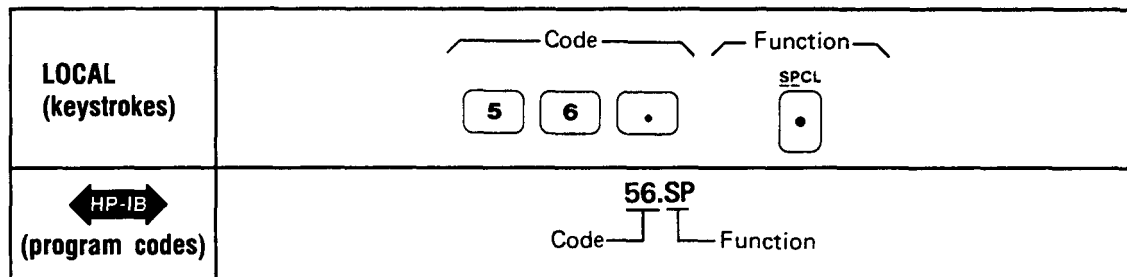

For example, the right display reads 147 (decimal) which equals 1001 0011 in binary.

Now, obtain the fine tune data:

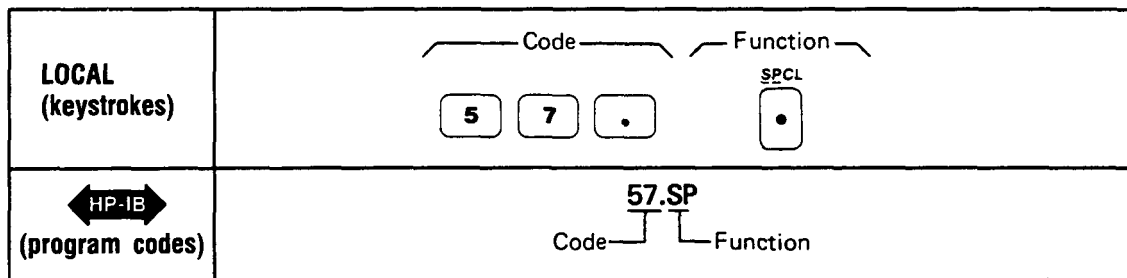

For example, the right display reads 128 (decimal) which equals 1000 0000 in binary.

Now combine the data into the required five-byte sequence:

Range (55.SPCL) = 1 (decimal) =	0001
Coarse Tune (56.SPCL) = 147 (decimal) =	1001 0011 (MSD) (LSD)
Fine Tune (56.SPCL) = 128 (Decimal) =	1000 0000 (MSD) (LSD)

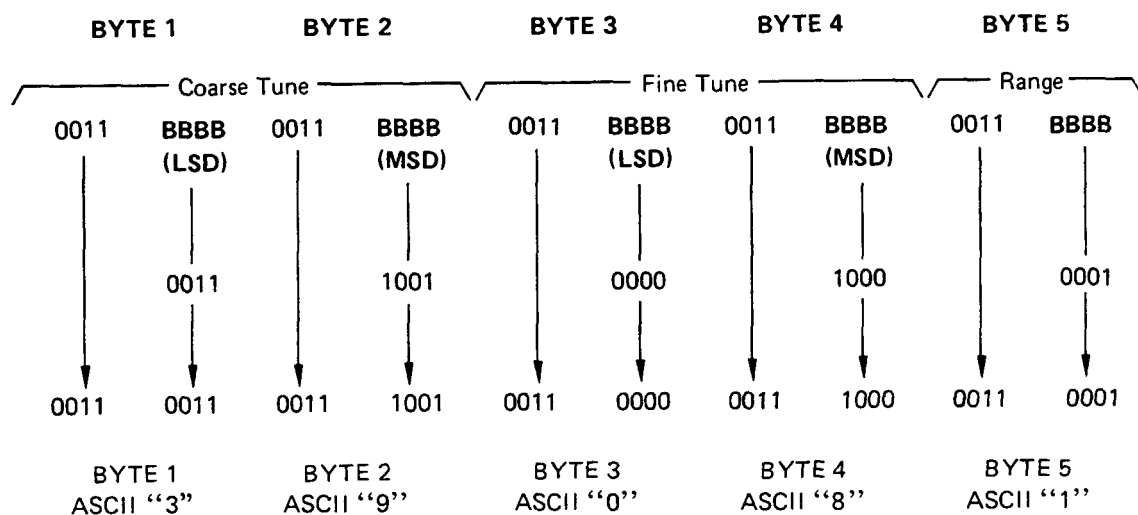

To select the Audio Analyzer's Rapid Source mode, issue the HP-IB code "RS". To tune the Audio Analyzer to 1 kHz in the Rapid Source mode, issue the ASCII string "39081".

Using a Hewlett-Packard Model 85B Desktop Controller, issue the command:

```
OUTPUT 728, 'RS39081'
```

Using a Hewlett-Packard Model 9825A Desktop Controller, issue the command:

```
wrt 728, 'RS39081'
```

When using a series of Rapid Source mode commands to create a tone burst, issue delays between commands. For example, when using an HP 9825A to obtain an approximate delay of 200 ms, issue the command:

```
wait 200
```

Or when using an HP 85B, issue the command:

```
WAIT 200
```

PROGRAM CODE



RS is the program code for initiating the Rapid Source tuning mode. The table below summarizes the Special Functions needed to acquire the tuning data.

Function	Program Code 
Range	55.SP
Coarse Tune	56.SP
Fine Tune	57.SP

INDICATIONS

When in Rapid Source mode, the Audio Analyzer's left display shows " — — — — — " (five dashes).

COMMENTS

Within a single frequency range, frequency switching is phase continuous.

RELATED SECTION

Rapid Frequency Count

RATIO and LOG/LIN (Special Function 11)

DESCRIPTION

The RATIO key can be used to compare any measurement (except frequency and power) to a reference value. The reference value can be the result of a previous measurement or a keyboard entry. The LOG/LIN (logarithmic/linear) key can be used to express the results in logarithmic or linear units. The following table shows which units are applicable to the individual measurement modes:

Measurement Mode	RATIO On		RATIO Off*	
	LIN	LOG	LIN	LOG
AC LEVEL	%	dB	V or mV*	dBm into 600Ω
DC LEVEL	%	dB	V or mV	dBm into 600Ω
SINAD	%	dB	%	dB*
SIG/NOISE	%	dB	%	dB
DISTN	%	dB	%*	dB
DISTN LEVEL	%	dB	V or mV*	dBm into 600Ω

*After initial power on, switching measurement mode results in the configuration indicated by the asterisks. In subsequent operations, the last setting of the LOG/LIN key is remembered for each measurement mode and applied to the new measurement.

When the RATIO LED is on, the measurement result is compared to a reference value. The reference value can be the result of a previous measurement or a keyboard entry. The LOG/LIN key allows any measurement result to be viewed in linear or logarithmic format.

The Audio Analyzer stores only one ratio reference at a time. When in ratio, if a new measurement is selected, ratio is disabled.

When returning to the previous measurement, it is possible to re-enter the ratio mode with the same factor as before using Special Function 11.0. Additionally, the ratio reference can be displayed using Special Function 11.1.

PROCEDURE

To use the RATIO key, set the display to the desired reference value. This can be done by adjusting the signal parameter being measured to a reference setting or by entering the reference on the numeric keys and then pressing RATIO. If the numeric keys are used to enter the ratio reference, the entry must be made in fundamental units (that is, for a ratio reference of 60 mV enter .06 regardless of the displayed value). The display will show the measurement result relative to the reference value. The units used with the right display depend upon the setting of the LOG/LIN key (see table above). Pressing the LOG/LIN key alternates the display between the LOG and the LIN functions. When the measurement mode is changed, the last setting of the LOG/LIN key for that mode is remembered and applied to the new measurement.

To re-enter ratio with the previous ratio reference or to read the reference, key in the corresponding Special Function code, and press the SPCL key. The Special Function codes are listed as follows:

Ratio Operation	Special Function Code	Program Code ↔HP-IB↔
Re-enter ratio with the previous reference.	11.0 SPCL	11.0SP
Read ratio reference.	11.1 SPCL	11.1SP

EXAMPLES

If the display shows 100 mV, to enter this value as the RATIO reference for future measurements:

LOCAL (keystrokes)	
↔HP-IB↔ (program codes)	<p>R1</p> <p>Ratio</p>

If the display shows 0.100V, to compare this to a value of 2V:

LOCAL (keystrokes)	
↔HP-IB↔ (program codes)	<p>2R1</p> <p>Data Ratio</p>

PROGRAM CODES

↔HP-IB↔ The HP-IB codes for re-entering ratio or for reading the reference are given above. The HP-IB codes for the RATIO and LOG/LIN keys are given below:

Function	Program Code ↔HP-IB↔
LOG	LG
LIN	LN
RATIO Off	R0
RATIO On	R1

INDICATIONS

When the instrument is displaying a ratio measurement, the **RATIO** key lights. The status of the **LOG/LIN** key can be determined by observing the current measurement mode, the measurement unit lights, and the table above.

COMMENTS

The ratio mode can also be used to view an extra digit of resolution when the right display is only showing three digits. Depending upon the current value displayed, pressing either **100 RATIO** or **1 RATIO** will cause an unscaled right display readout (that is, the numbers are correct but the decimal point may not be in the correct position). However, an extra digit of resolution is displayed (for example, if 1.58 was originally displayed, the new display might indicate 1.576). Note that the units annunciator will change to % and should be interpreted properly.

Ratio cannot be used with a frequency measurement. Also, if a negative reference is entered, the ratio indication will be displayed in absolute (unsigned) value.

The **LOG** function cannot be used with a reference that is zero or negative. If the reference is zero, Error 20 (entered value out of range) is displayed. If the reference is negative, Error 11 (calculated value out of range) is displayed.

RELATED SECTIONS

- AC Level
- DC Level
- Distortion
- Distortion Level
- Error Message Summary
- Signal-to-Noise
- SINAD
- Special Functions

Read Display to HP-IB (Special Function 20)

DESCRIPTION

The Audio Analyzer can be set to read the information shown in either the left or right display to the HP-IB. Special Function 20 allows the operator to manually determine which display's information will be placed on the HP-IB. This capability is typically used in the Talk Only Mode when logging data to a monitoring device. (Note that when set to Listen Only, the Audio Analyzer can not place data on the bus. If it is set to talk and listen both, front-panel control is relinquished and HP-IB codes RR and RL determine the data output.)

PROCEDURE

To set the Audio Analyzer to output data to the HP-IB from either the left or right display, key in the corresponding Special Function code; and then press the SPCL key.

Display Read	Special Function Code	Program Code ↔ HP-IB ↔
Right	20.0 SPCL	20.0SP (or RR)
Left	20.1 SPCL	20.1SP (or RL)

EXAMPLE

To read the left display to the HP-IB:

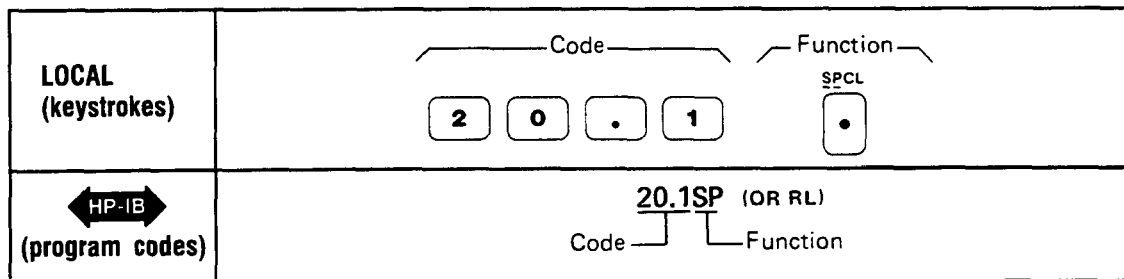

PROGRAM CODES

↔ HP-IB ↔ For HP-IB codes, refer to the table in the *Procedure* above.

INDICATIONS

As the numeric code is entered, both displays will blank, and the entered code will appear in the left display. When the SPCL key is pressed, the SPCL key does not light. However, both displays will again blank and four dashes will momentarily appear in the right display. Both displays then return to the display that is appropriate for the current measurement mode.

HP-IB OUTPUT

◀ HP-IB ▶ The instrument outputs data from the display in the following format:

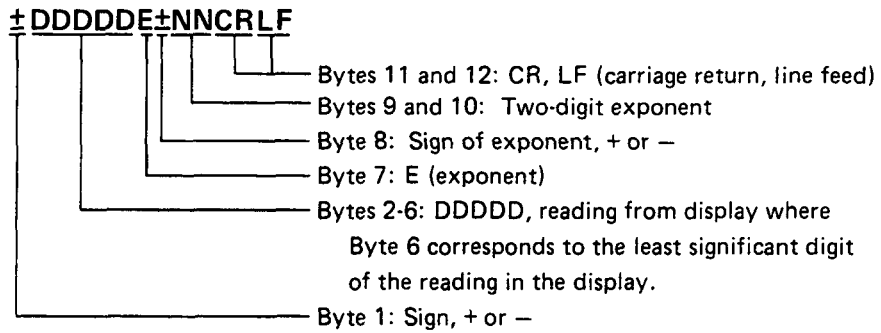

Data is always output in fundamental units (that is, Hz, %, dB, or V).

Error messages and the voltage value in dc level mode are always read out regardless of the status of the Read Display to HP-IB commands.

RELATED SECTION

Special Functions

Service Request Condition (Special Function 22)

DESCRIPTION

The Audio Analyzer will issue a Require Service message under various circumstances. For example, a Require Service message will always be issued if an HP-IB code error occurs. Using the keyboard and the SPCL key, the operator may enable one or more conditions to cause the Require Service message to be issued. Whenever the enabled condition occurs, it sets both the bit corresponding to the condition and bit 7 (RQS bit) in the Status Byte. The bits set in the status byte and the Require Service message are not cleared unless the status byte is read (by serial polling), a Clear message is received and executed by the Audio Analyzer, or a Controller Reset or Controller Clear Service Special Function is performed. The enabled Service Request conditions are always disabled again whenever a Clear message is received and executed by the Audio Analyzer or whenever a Controller Reset or Controller Clear Service Special Function is performed. Automatic operation does not clear a Require Service message.

PROCEDURE

To enable one or more conditions to cause the Audio Analyzer to issue a Require Service message, sum the weights of the conditions to be enabled (from the table below). This sum becomes the code suffix of Special Function 22. Enter the Special Function code (prefix, decimal, and suffix) via the numeric keyboard, then press the SPCL key. An HP-IB code error (weight 2) will always cause a Require Service message. This condition cannot be disabled, and if the weight is not summed in, it will be assumed by the instrument.

Condition	Weight
Data ready	1
HP-IB code error	2
Instrument error	4

EXAMPLE

To set the Audio Analyzer to send a Require Service message when an instrument error occurs (or when an HP-IB code error occurs) first compute the Special Function suffix by summing the weights corresponding to those conditions:

$$(2) + 4 = 6$$

Then enter the code:

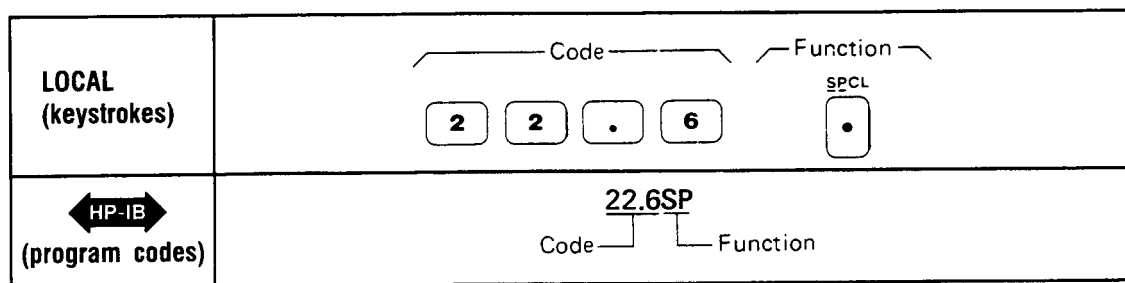

PROGRAM CODES

 Compute the Special Function code as described under *Procedure* above. SP is the HP-IB code for the SPCL key.

INDICATIONS

As the numeric code is entered, it will appear on the front-panel display. When the SPCL key is pressed, the display returns to show the measurement previously selected. Special Function 22 has no effect on the SPCL key light. When any enabled condition occurs, both the RQS bit and the bit corresponding to the enabled condition are set in the status byte, and the SRQ control line on the HP-IB will be set true. The Audio Analyzer's status byte is shown below for reference.

Audio Analyzer's Status Byte

Bit	8	7	6	5	4	3	2	1
Weight	128	64	32	16	8	4	2	1
Condition	0 (always)	RQS	0 (always)	0 (always)	0 (always)	Instru- ment Error	HP-IB Code Error	Data Ready

COMMENTS

For more information on HP-IB operation, serial polling, and the Status Byte message, refer to the HP-IB discussion titled *HP-IB Operation* appearing earlier in Section 3 of this manual.

The HP-IB Address Special Function provides a convenient means to determine at any time whether a Require Service message is being issued by the Audio Analyzer.

RELATED SECTIONS

- HP-IB Address
- HP-IB Operation (appears earlier in Section 3)

Signal-to-Noise

DESCRIPTION

The instrument uses its internal source to make signal-to-noise measurements. The source is set to a specified value and alternately turned on and off. The measurement is made by first determining the following value:

$$D = \frac{\text{signal} + \text{noise}}{\text{noise}}$$

D is then converted into the appropriate measurement units as follows:

$$\% \text{ units} = D \times 100\%$$

$$\text{dB units} = 20\log D$$

The **RATIO** key can be used to compare these values to a predetermined ratio reference (refer to *RATIO and LOG/LIN*).

The signal-to-noise measurement can be made on source signals from 50 Hz to 100 kHz and from 50 mV to 300V.

PROCEDURE

Set the internal source to the desired frequency and amplitude. Press the **S** (Shift) key and then the **SIG/NOISE** key.

EXAMPLE

To make a signal-to-noise measurement at 1V and 1 kHz:

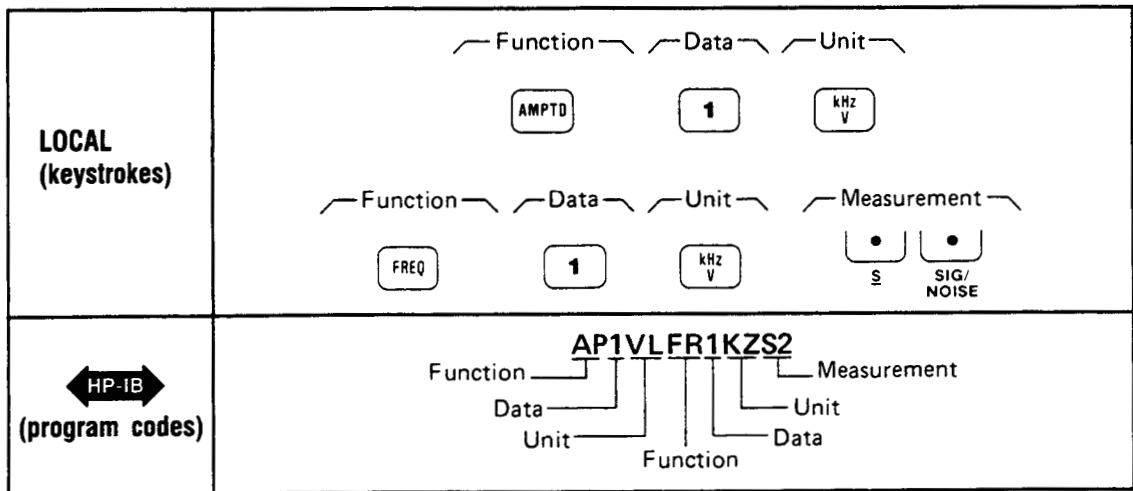

PROGRAM CODES

HP-IB S2 is the HP-IB code for the signal-to-noise measurement.

INDICATIONS

When signal-to-noise is selected, the LEDs in the S (Shift) and the SIG/NOISE keys will light. The appropriate signal-to-noise information is displayed.

MEASUREMENT TECHNIQUE

In the signal-to-noise measurement mode, the controller automatically sets the input attenuation and the gain settings of various amplifiers. This control ensures that the signal amplitude is within the proper range for the output detector. In addition, the controller alternately turns the oscillator on and off for each measurement. The output detector converts the two ac signals (signal + noise and noise) to dc. The dc voltmeter measures the dc. The controller then corrects for the gain and attenuation, computes the ratio, and displays the results in the appropriate units. The frequency of the input signal is also measured and displayed.

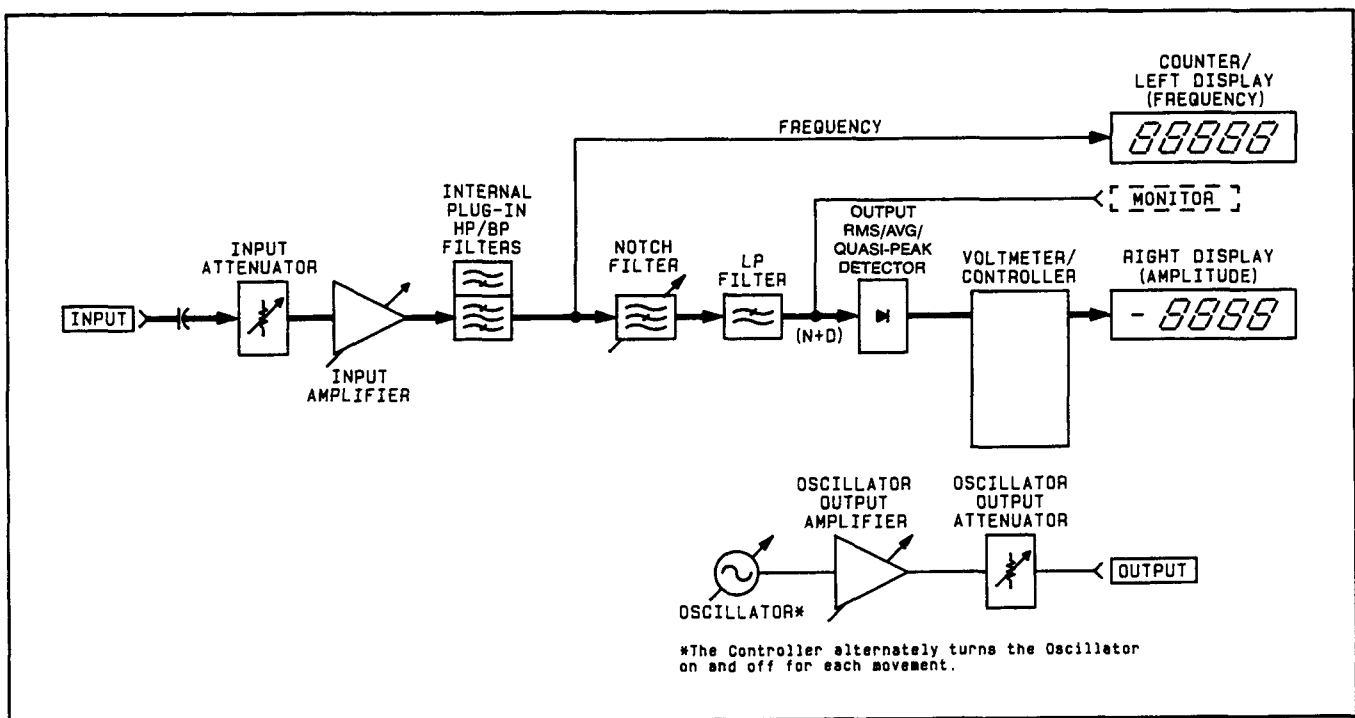

Signal-To-Noise Measurement Block Diagram

COMMENTS

The Audio Analyzer's internal source must be used as the signal stimulus when making signal-to-noise measurements.

RELATED SECTIONS

- Amplitude
- Frequency
- RATIO and LOG/LIN

SINAD

DESCRIPTION

The Audio Analyzer measures SINAD (Signal to Noise And Distortion) by first determining the following value:

$$S = \frac{\text{signal, noise, and distortion}}{\text{noise and distortion}}$$

S is then converted into the appropriate measurement units as follows:

$$\% \text{ units} = S \times 100\%$$

$$\text{dB units} = 20\log S$$

A SINAD measurement can be made on signals from 20 Hz to 100 kHz and from 50 mV to 300V. SINAD measurements are generally made to determine the sensitivity of a receiver. The Audio Analyzer internal notch filter is automatically coarse-tuned to the frequency of the internal oscillator to permit measurements in the presence of large amounts of impurities and to assure that the fundamental frequency is tuned out. The notch filter then fine tunes itself to the signal at the instrument's input. If an external oscillator is used, it must be tuned to within 5% of the internal oscillator frequency. If it is not, the notch filter will not tune to the fundamental frequency of the input signal.

PROCEDURE

First, manually set the internal oscillator to the frequency desired. To do this press **FREQ**, enter the numeric value for the desired frequency, and then press the appropriate unit key (for example, kHz). Next press **SINAD**. If the internal source is being used as a stimulus, also key in the desired amplitude for the modulation signal. The SINAD ratio can then be read on the right display or the SINAD meter (if within range). Special Function 7 can be used to change the SINAD meter range.

EXAMPLE

To set the internal source to 1 kHz and select SINAD:

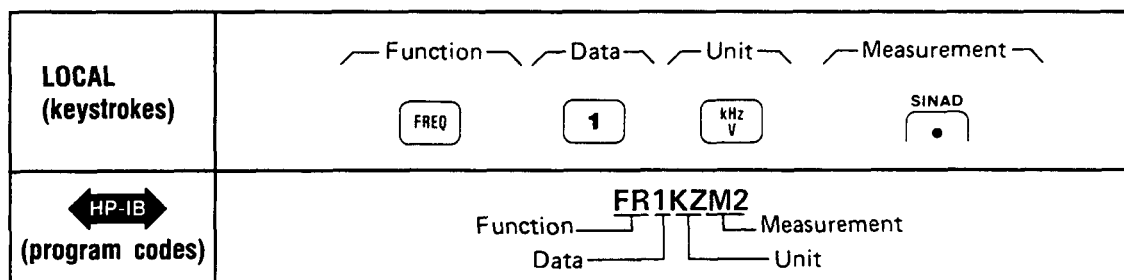

PROGRAM CODE

M2 is the HP-IB code for the SINAD measurement.

INDICATIONS

When either the **FREQ** or **AMPTD** key is pressed, the currently programmed values are displayed in the left and right displays respectively. When the numeric data is entered, the numbers appear in the left display. When the unit keys are pressed, both displays blank and four dashes are momentarily displayed in the left display. The displays then return to the normally displayed information for the currently selected measurement mode. When **SINAD** is pressed, the LED in the **SINAD** key lights and the appropriate **SINAD** information for the input signal is displayed.

MEASUREMENT TECHNIQUES

In the **SINAD** measurement mode, the controller automatically sets the input attenuation and the gain of various amplifiers. This is accomplished by measuring the signal with the ranging detector. This control ensures that the signal amplitude is within the proper range of the input and output detectors. In addition, the controller coarse tunes the notch filter to the programmed frequency of the oscillator to ensure that the Audio Analyzer will not be mistuned. The oscillator is normally used as the source of the test signal. If an external signal source is used, it must be tuned within 5% of the oscillator's programmed frequency. The input detector converts the combined signal + noise + distortion ac signal to dc. The notch filter then removes the fundamental signal and the output detector converts the noise + distortion ac signal to dc. The dc voltmeter measures both signals. The controller then corrects for the programmed gain and attenuation, computes the ratio, and displays the results in the appropriate units. The frequency of the input signal is also measured and displayed. As a convenience, the **SINAD** meter displays the **SINAD** measurement results if within its range. The meter is specially marked for EIA and CEPT sensitivity and selectivity.

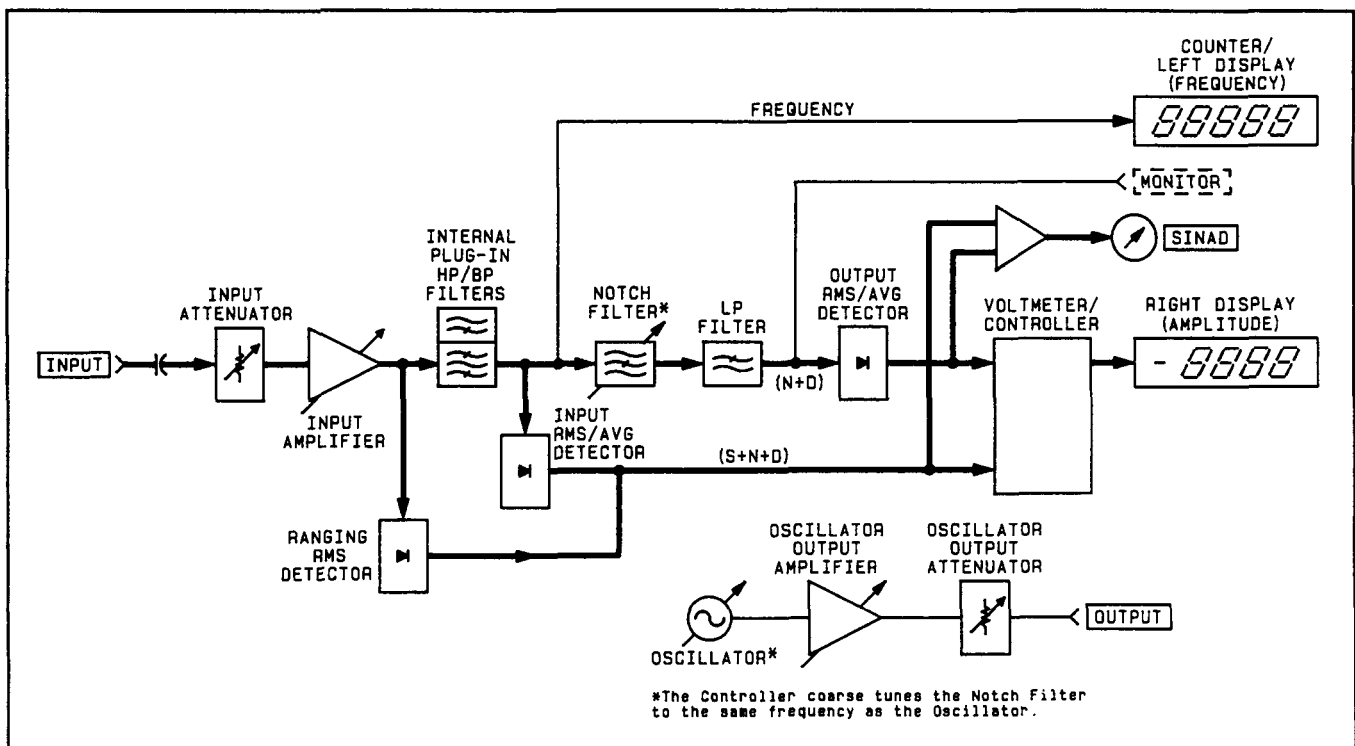

SINAD Measurement Block Diagram

COMMENTS

If an external oscillator is used, it must be tuned to within 5% of the internal oscillator frequency.

SINAD can be measured with either the true rms or average-responding detector. Most applications specify true rms detection. Using the Quasi-peak Detector for SINAD measurements is not recommended.

During a SINAD measurement, the output detector uses increased filtering to obtain more consistent readings in the presence of noise.

Special Function 7 can be used to change the SINAD meter range (refer to Special Functions).

For SINAD ratios less than 25 dB, the digital display is automatically rounded to the nearest 0.5 dB to reduce digit flicker.

The SINAD meter has hysteresis. The trip point for the 24 dB range is >18 dB, and the trip point for the 18 dB range is <17 dB.

RELATED SECTIONS

Amplitude
Detector Selection
Frequency
Special Functions

Special Functions

DESCRIPTION

General Information. Special Functions extend user control of the instrument beyond that normally available from dedicated front-panel keys. They are intended for the user who has an understanding of the instrument and the service technician who needs arbitrary control of the instrument functions. Special Functions are accessed via keyboard or HP-IB entry of the appropriate numeric code and terminated by the SPCL key or HP-IB code (refer to *Procedures* below). The codes comprise a prefix, decimal, and suffix. Special Functions are disabled by a variety of means, depending upon the function. Refer to the comprehensive listings below for actions which clear or disable any Special Function. Special Functions are grouped by their prefixes into three categories as follows:

Prefix 0

This is the Direct Control Special Function and is intended for use in servicing the Audio Analyzer. All instrument error messages and safeguards are inactive. This is discussed in detail in Section 8. If the Direct Control is entered inadvertently, press AUTOMATIC OPERATION.

Prefixes 1 to 39

These are the User Special Functions which are used during normal instrument operation when a special configuration, a special measurement, or special information is required. All error messages and some safeguards remain in effect unless the operator disables them. These Special Functions are described below.

Prefixes 40 to 99

These are the Service Special Functions used to assist in troubleshooting an instrument fault. The functions available are quite diverse — special internal measurements, software control, and special service tests and configurations. Most instrument safeguards are relinquished. These Special Functions are discussed in detail in Section 8. If a Service Special Function is entered inadvertently, press AUTOMATIC OPERATION.

Viewing Special Function States. In addition to completing the entry of Special Function codes, the SPCL key allows viewing of some Special Function settings. The operator-requested settings of Special Functions prefixed 1 through 8 may be viewed by pressing the SPCL key once (following no numeric entry). This display is called the Special Display. If some of these Special Functions are in automatic modes (generally the 0-suffix setting), the actual instrument settings of these functions may be displayed by pressing the SPCL key a second time while the Special Display is active. This display is called the Special Special Display. If desired, these displays can be cleared by pressing any key except the LCL, numeric, or S (Shift) keys. (While either display is active, pressing the SPCL key will switch to the other display.) A summary of User Special Functions is given on the following pages. Following the summary are procedures for using Special Display. These displays are also illustrated and explained.

Special Function Summary (1 of 4)

Special Function		HP-IB Code ← HP-IB →	Description	Lights SPCL key	Disable			
Name	Code				AUTO OP. key	Any Meas. key	CLEAR key	All keys*
Input Level Range (except DC level)	1.0	1.0SP	Automatic selection	N	-	-	-	-
	1.1	1.1SP	300V range	Y	Y	N	N	N
	1.2	1.2SP	189V range	Y	Y	N	N	N
	1.3	1.3SP	119V range	Y	Y	N	N	N
	1.4	1.4SP	75.4V range	Y	Y	N	N	N
	1.5	1.5SP	47.6V range	Y	Y	N	N	N
	1.6	1.6SP	30.0V range	Y	Y	N	N	N
	1.7	1.7SP	18.9V range	Y	Y	N	N	N
	1.8	1.8SP	11.9V range	Y	Y	N	N	N
	1.9	1.9SP	7.54V range	Y	Y	N	N	N
	1.10	1.10SP	4.76V range	Y	Y	N	N	N
	1.11	1.11SP	3.00V range	Y	Y	N	N	N
	1.12	1.12SP	1.89V range	Y	Y	N	N	N
	1.13	1.13SP	1.19V range	Y	Y	N	N	N
	1.14	1.14SP	0.754V range	Y	Y	N	N	N
	1.15	1.15SP	0.476V range	Y	Y	N	N	N
	1.16	1.16SP	0.300V range	Y	Y	N	N	N
	1.17	1.17SP	0.189V range	Y	Y	N	N	N
	1.18	1.18SP	0.119V range	Y	Y	N	N	N
1.19	1.19SP	0.0754V range	Y	Y	N	N	N	
Input Level Range (DC Level only)	2.0	2.0SP	Automatic selection	N	-	-	-	-
	2.1	2.1SP	300V range	Y	Y	N	N	N
	2.2	2.2SP	64V range	Y	Y	N	N	N
	2.3	2.3SP	16V range	Y	Y	N	N	N
	2.4	2.4SP	4V range	Y	Y	N	N	N
Post-Notch Gain	3.0	3.0SP	Automatic selection	N	-	-	-	-
	3.1	3.1SP	0 dB gain	Y	Y	N	N	N
	3.2	3.2SP	20 dB gain	Y	Y	N	N	N
	3.3	3.3SP	40 dB gain	Y	Y	N	N	N
	3.4	3.4SP	60 dB gain	Y	Y	N	N	N
Hold Decimal Point (right display only)	4.0	4.0SP	Automatic selection	N	-	-	-	-
	4.1	4.1SP	DDDD. range ¹	Y	Y	N	N	N
	4.2	4.2SP	DDD.D range	Y	Y	N	N	N
	4.3	4.3SP	DD.DD range	Y	Y	N	N	N
	4.4	4.4SP	D.DDD range	Y	Y	N	N	N
	4.5	4.5SP	0.DDDD range ²	Y	Y	N	N	N
	4.6	4.6SP	DD.DD mV range	Y	Y	N	N	N
	4.7	4.7SP	D.DDD mV range	Y	Y	N	N	N
4.8	4.8SP	0.DDDD mV range ²	Y	Y	N	N	N	

N = No; - = Not Applicable; Y = Yes; * Except the LCL, S(Shift), and Numeric Keys.

¹ Decimal Point not displayed

² Leading zero not displayed. Shown here in table to clarify decimal point position.

Special Function Summary (2 of 4)

Special Function		HP-IB Code ↔ HP-IB ↔	Description	Lights SPCL key	Disable			
Name	Code				AUTO OP. key	Any Meas. key	CLEAR key	All keys*
Post-Notch Detector Filtering (except in SINAD)	5.0	5.0SP	Fast RMS Detector	N	-	-	-	-
	5.1	5.1SP	Slow RMS Detector	Y	Y	N	N	N
	5.2	5.2SP	Fast Average Detector	Y	Y	N	N	N
	5.3	5.3SP	Slow Average Detector	Y	Y	N	N	N
	5.7	5.7SP	Quasi-Peak Detector	Y	Y	N	N	N
Notch Tune	6.0	6.0SP	Automatic notch tuning	N	-	-	-	-
	6.1	6.1SP	Hold notch tuning	Y	Y	N	N	N
SINAD Meter Range	7.0	7.0SP	0 to ≈18 dB range	N	-	-	-	-
	7.1	7.1SP	0 to ≈24 dB range	Y	Y	N	N	N
Error Disable	8.0	8.0SP	All errors enabled	N	-	-	-	-
	8.1	8.1SP	Disable Analyzer errors (Errors 12-17, 31, and 96)	Y	Y	N	N	N
	8.2	8.2SP	Disable Source errors (Error 18 and 19)	Y	Y	N	N	N
	8.3	8.3SP	Disable both Analyzer and Source errors	Y	Y	N	N	N
Hold Settings	9.0	9.0SP	Hold input level ranges, post-notch gain, decimal point and notch tuning at present settings.	Y	Y	N	N	N
Display Source Settings	10.0	10.0SP	Display source settings as entered. Frequency in left display/ amplitude in right display.	Y	Y	Y	N	N
Re-enter Ratio Mode	11.0	11.0SP	Restore last RATIO reference and enter RATIO mode if allowed.	N	N	Y	N	N
	11.1	11.1SP	Display RATIO reference	Y	Y	Y	Y	N
Signal-to-Noise Measurements Delay (Continued on next page)	12.0	12.0SP	Automatic Selection	N	-	-	-	-
	12.1	12.1SP	200 ms delay	Y	Y	Y	N	N
	12.2	12.2SP	400 ms delay	Y	Y	Y	N	N
	12.3	12.3SP	600 ms delay	Y	Y	Y	N	N
	12.4	12.4SP	800 ms delay	Y	Y	Y	N	N
12.5	12.5SP	1.0s delay	Y	Y	Y	N	N	

N = No; - = Not Applicable; Y = Yes; *Except the LCL, S(Shift), and Numeric Keys.

Special Function Summary (3 of 4)

Special Function		HP-IB Code ↔ HP-IB ↔	Description	Lights SPCL key	Disable			
Name	Code				AUTO OP. key	Any Meas. key	CLEAR key	All keys*
Signal-to-Noise (Cont'd)	12.6	12.6SP	1.2s delay	Y	Y	Y	N	N
	12.7	12.7SP	1.4s delay	Y	Y	Y	N	N
	12.8	12.8SP	1.6s delay	Y	Y	Y	N	N
	12.9	12.9SP	1.8s delay	Y	Y	Y	N	N
X-Y Recorder	13.0	13.0SP	Enable plot	N	N	Y	Y	N
	13.1	13.1SP	Disable plot	Y	Y	N	N	N
Time Between Measurements	14.0	14.0SP	Minimum time between measurements	N	-	-	-	-
	14.1	14.1SP	Add 1s between measurements	Y	Y	N	N	N
SINAD and Signal-to-Noise Display Resolution	16.0	16.0SP	0.01 dB above 25 dB; 0.5 dB below 25 dB	N	-	-	-	-
	16.1	16.1SP	0.01 dB all ranges	Y	Y	N	N	N
Sweep Resolution (Maximum 255 points/sweep)	17.0	17.0SP	10 points/decade	N	-	-	-	-
	17.1	17.1SP	1 point/decade	Y	Y	N	N	N
	17.2	17.2SP	2 points/decade	Y	Y	N	N	N
	17.3	17.3SP	5 points/decade	Y	Y	N	N	N
	17.4	17.4SP	10 points/decade	Y	Y	N	N	N
	17.5	17.5SP	20 points/decade	Y	Y	N	N	N
	17.6	17.6SP	50 points/decade	Y	Y	N	N	N
	17.7	17.7SP	100 points/decade	Y	Y	N	N	N
	17.8	17.8SP	200 points/decade	Y	Y	N	N	N
	17.9	17.9SP	500 points/decade	Y	Y	N	N	N
Display Level in Watts	19.0	19.0SP	Display level as watts into 8 ohms	Y	Y	Y	Y	Y
	19.NNN	19.NNNSP	Display level as watts into NNN ohms	Y	Y	Y	Y	Y
Read Display to HP-IB ↔ HP-IB ↔	20.0	20.0SP	Read right display	N	N	N	N	N
	20.1	20.1SP	Read left display	N	N	N	N	N

N = No; - = Not Applicable; Y = Yes; *Except the LCL, S(Shift), and Numeric Keys.

Special Function Summary (4 of 4)

Special Function		HP-IB Code ↔ HP-IB ↔	Description	Lights SPCL key	Disable			
Name	Code				AUTO OP. key	Any Meas. key	CLEAR key	All keys*
HP-IB Address ↔ HP-IB ↔	21.0	21.0SP	Displays HP-IB address (in binary) in left display; right display in form TLS where T=1 means talk only; L=1 means listen only; S=1 means SRQ.	Y	Y	Y	Y	Y
	21.1	21.1SP	Displays HP-IB address in decimal.					
Service Request ↔ HP-IB ↔ (HP-IB Service Request Condition)	22.N	22.NSP	Enable a condition to cause a service request, N is the sum of any combination of the weighted conditions below: 1-Data Ready 2-HP-IB error 4-Instrument error The instrument powers up in the 22.2 state (HP-IB error).	N	N	N	N	N
600Ω Source Output Impedance 50Ω Source Output Impedance	47.0	47.0SP		N	-	-	-	-
	47.1	47.1SP		Y	Y	N	N	N
N = No; - = Not Applicable; Y = Yes; *Except the LCL, S(Shift), and Numeric Keys.								

PROCEDURE

Entering Special Functions. To use a Special Function, key in the corresponding code then press the SPCL key.

Special Display. To display the user-requested modes of Special Functions 1 through 8, press the SPCL key alone one time. The digit position (noted beneath the displays) corresponds to the Special Function prefix, and the number displayed in that position corresponds to the Special Function suffix.

Special Special Display. To determine the actual instrument settings of functions prefixed 1 through 8, press the SPCL key alone once while Special Display is active. (If the Special Display described above is not in effect, press the SPCL key twice to get this display.) The digit position corresponds to the function prefix, and the number displayed in that digit corresponds to the function suffix.

EXAMPLES

Entering Special Functions. To display the frequency and the amplitude settings entered for the source (Special Function 10):

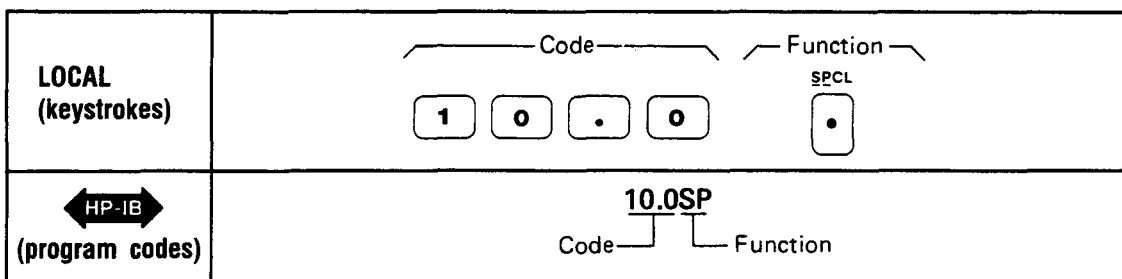

Special Display. When SPCL is pressed alone once and the following display results,

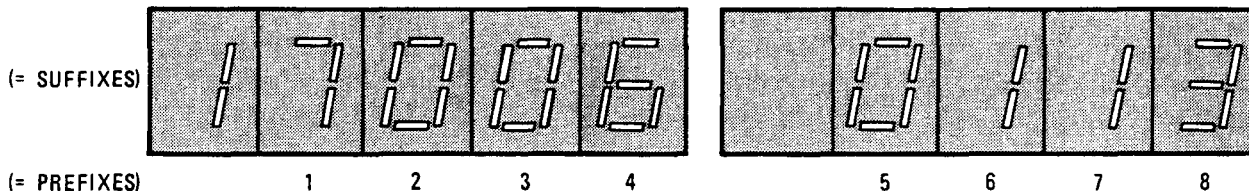

This display indicates that the following Special Functions were selected by the operator:

Special Function		User-Requested Setting
Code	Name	
1.17	Input Level Range (Except DC Level)	0.189V range
2.0	Input Level Range (DC Level only)	Automatic Selection
3.0	Post-Notch Gain	Automatic Selection
4.6	Hold Decimal Point (right display only)	DD.DD mV range
5.0	Post-Notch Detector Filtering (Except in SINAD)	Fast RMS Detector
6.1	Notch Tune	Hold notch tuning
7.1	SINAD Meter Range	0 to 24 dB range
8.3	Error Disable	Disable both analyzer and source errors

Special Special Display. When SPCL is pressed again while the Special Display is active and the following display results, the actual instrument settings are tabulated below.

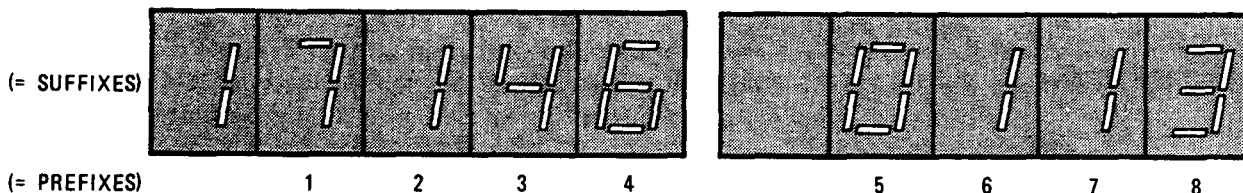

Special Function		Actual Instrument Setting
Code	Name	
1.17	Input Level Range (Except DC Level)	0.189V range
2.1	Input Level Range (DC Level only)	300V range
3.4	Post-Notch Gain	60 dB Range
4.6	Hold Decimal Point	DD.DD mV range
5.0	Post-Notch Detection Filtering (Except in SINAD)	Fast RMS Detector
6.1	Notch Tune	Hold notch tuning
7.1	SINAD Meter Range	0 to 24 dB range
8.3	Error Disable	Disable both analyzer & source errors

PROGRAM CODES

HP-IB HP-IB Codes for the Special Functions are summarized in the *Special Function Summary* above.

INDICATIONS

Entering Special Functions. As the numeric code is entered, both displays will blank and the entered code will appear in the left display. When the SPCL key is pressed, both displays will again blank and four dashes will momentarily appear in the right display. These dashes are replaced with the appropriate reading for the selected measurement mode.

COMMENTS

If a User Special Function (prefixes 1 to 39) has a suffix of zero, the zero need not be entered. For example, 10.0 SPCL equals 10. SPCL. (However, 1.1 SPCL does not equal 1.10 SPCL.) If when entering a Special Function code, Error 21 (invalid key sequence) is displayed, the Special Function requested has not been executed. Entry of invalid special function suffixes results in display of Error 23. For additional information on *Direct Control Special Functions* (prefix 0) or *Service Special Functions* (prefixes 40 to 99) refer to Section 8.

RELATED SECTIONS

- Automatic Operation
- Default Conditions and Power-up Sequence
- Special Function Summary table (under *Description* above)

Sweep

DESCRIPTION

The Audio Analyzer source frequency can be logarithmically swept. The sweep range can be set between any two frequencies in the range of 20 Hz and 100 kHz. The source frequency changes in discrete steps rather than in a continuous analog manner. The number of frequency points in a sweep is determined by the sweep width (the ratio of the entered stop and start frequencies) and the sweep resolution selected. The maximum number of points allowable in one sweep is 255. For more information about the number of points in a sweep and sweep resolution refer to *Sweep Resolution*. Using the sweep feature in conjunction with one of the Audio Analyzer measurement modes provides swept measurement capability. Swept response measurement can be plotted by connecting an X-Y recorder to the Audio Analyzer recorder x- and y-axis outputs which are located on the rear panel. Any measurement result can be plotted as the source is swept in frequency.

PROCEDURE

Sweep Range Selection. The START FREQ and the STOP FREQ keys are used to set the starting and stopping points of the frequency sweep. To select a start frequency, press the START FREQ key, then the appropriate numeric data and unit keys. To select a stop frequency, press the STOP FREQ key, then the appropriate numeric data and unit keys. To display the currently programmed start or stop frequency, press and hold the respective START FREQ or STOP FREQ key.

Sweep Mode Selection. The SWEEP key puts the instrument in the sweep mode. The source does not start sweeping until a signal is sensed at the INPUT. At the end of the sweep, the sweep circuitry is turned off (no longer in sweep mode). To stop in midsweep, press the CLEAR key. Pressing the SWEEP key again will reset and restart the sweep.

EXAMPLE

To sweep the source frequency from 100 Hz to 25 kHz:

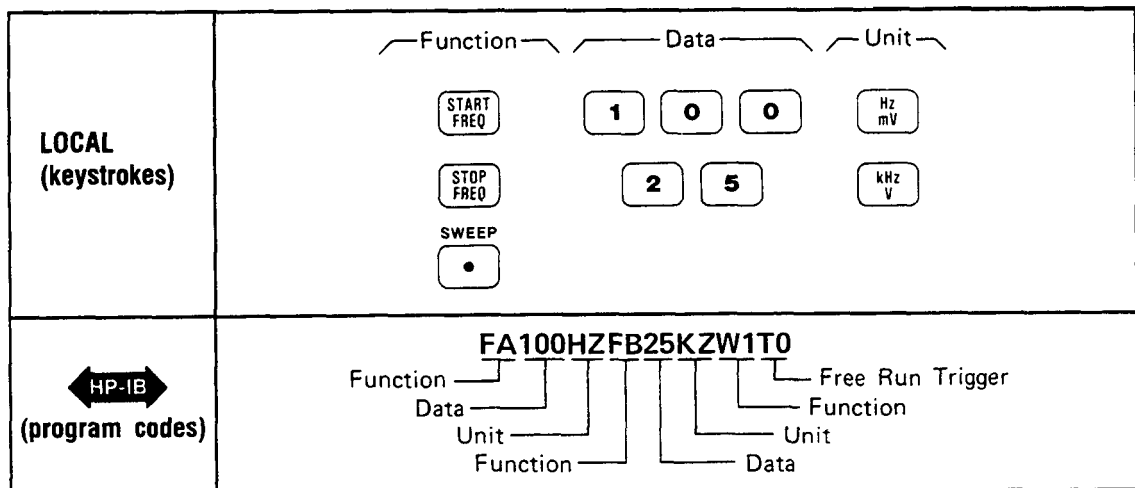

PROGRAM CODES



Key	Program Codes
START FREQ	FA
STOP FREQ	FB
SWEEP OFF	W0
SWEEP ON	W1
kHz	KZ
Hz	HZ

NOTE

Free Run triggering (code T0) is the only trigger mode allowed when using the sweep function (code W1). Any other triggering (codes T1, T2, or T3) or use of CLEAR key triggering will cause only the start frequency point to be displayed, plotted, and read to the HP-IB. Both the rear-panel X AXIS and Y AXIS outputs will be inhibited from continuing beyond the start frequency point.

INDICATIONS

When the START FREQ or STOP FREQ key is pressed, the left display shows the currently programmed start or stop frequency and the source goes to that frequency. As the new start or stop frequency is entered, it will appear on the left display. When the unit key is pressed, the left display returns to show the input signal frequency. (The source remains at the start or stop frequency.)

When the SWEEP key is pressed, the LED within the SWEEP key will light. The light indicates that the instrument is in the sweep mode. Note, the light does not necessarily mean that the source is sweeping. When the sweep is completed, the light will turn off.

COMMENTS

The Audio Analyzer powers up with start and stop frequencies of 20 Hz and 20 kHz respectively.

Reverse sweep (that is, sweeping from a higher frequency to a lower frequency) is obtained by simply entering a start frequency which is higher than the stop frequency.

During the sweep mode, all the front-panel keys remain active, hence they affect the sweep function. Pressing certain front-panel keys while the instrument is in the sweep mode can cause an undefined state or an error condition. Therefore, it is recommended that only the following keys be pressed during a sweep: CLEAR, STOP FREQ, START FREQ, AUTOMATIC OPERATION, and SWEEP. The function of these keys during sweep mode is described below.

CLEAR and AUTOMATIC OPERATION: When pressed the keys stop the sweep. The source remains tuned to the frequency point where the sweep was stopped. However, the sweep cannot be restarted from that point.

START FREQ and STOP FREQ: These keys when pressed, stop the current sweep and tune the source to either the currently programmed start or stop frequency. Which frequency the source is tuned to, depends upon which key was pressed.

SWEEP: The sweep key stops the current sweep, retunes the source frequency back to the start frequency, and restarts the sweep from that point.

Errors which are signified by the two dashes or four dashes on the right display stop the sweep but do not take the instrument out of sweep mode. As soon as the error-causing condition is removed, the sweep starts again from where it left off.

Nonrecoverable errors, such as Error 10, Error 11, etc., require that the error-causing condition be removed and the error message be cleared before another sweep can be initiated. Note that the sweep cannot continue from the frequency point at which the error first occurred.

The time required to complete a sweep depends on factors such as measurement mode, sweep width, sweep resolution, and input signal level.

RELATED SECTIONS

Plot Limit
Sweep Resolution
X-Y Recording

Sweep Resolution (Special Function 17)

DESCRIPTION

The Audio Analyzer powers up with a sweep resolution of 10 points/decade. However, the sweep resolution can be manually selected from 1 to 500 points/decade by keyboard entry using the SPCL key.

PROCEDURE

To select a different sweep resolution, key in the corresponding Special Function code, then press the SPCL key.

Sweep Resolution	Special Function Code	Program Code ↔ HP-IB ↔
10 points/decade	17.0 SPCL	17.0SP
1 point/decade	17.1 SPCL	17.1SP
2 points/decade	17.2 SPCL	17.2SP
5 points/decade	17.3 SPCL	17.3SP
10 points/decade	17.4 SPCL	17.4SP
20 points/decade	17.5 SPCL	17.5SP
50 points/decade	17.6 SPCL	17.6SP
100 points/decade	17.7 SPCL	17.7SP
200 points/decade	17.8 SPCL	17.8SP
500 points/decade	17.9 SPCL	17.9SP

EXAMPLE

To set the sweep resolution to 100 points/decade:

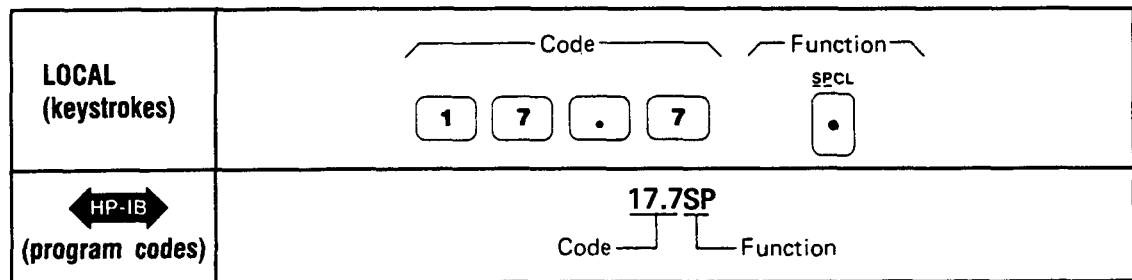

PROGRAM CODES

↔ HP-IB ↔ For HP-IB codes, refer to *Procedure* above.

INDICATIONS

As the numeric code is entered, it will appear on the left display. When the SPCL key is pressed, the left display returns to show the input signal frequency. Unless Special Function code 17.0 was entered, the light within the SPCL key will turn on (if not already on). If the light is already on, it will remain on.

COMMENTS

The maximum number of points in a sweep is restricted to 255 points. Therefore, if a sweep resolution of 500 points/decade is required the sweep span has to be limited to approximately half a decade.

The frequency points in a sweep can be computed by using the following formulas:

$$\text{Enter: Frequency} = \text{START FREQ} \times 10^{n/k}$$

Where n = the frequency point number and $n = 0$ is for the start frequency

k = number of points per decade.

For reverse sweep the frequency point formula becomes:

$$\text{Enter: Frequency} = \text{START FREQ} \times 10^{-n/k}$$

The following example illustrates how to compute the frequency points for a 50 Hz to 30 kHz sweep with a sweep resolution of 5 points/decade (Special Function code 17.3).

1. Compute the sweep range in decades using the formula:

$$\text{sweep range (in decades)} = \log \frac{\text{STOP FREQ}}{\text{START FREQ}}$$

For this example:

$$\text{sweep range} = \log 30\,000 / 50$$

$$\text{sweep range} = 2.78 \text{ decades}$$

2. Compute the total number of points in a sweep using the formula:

$$\text{total number of points} = \text{points/decade} \times \text{sweep range}$$

Since the number of points in a sweep is always an integer, round off the result from the above equation to the nearest integer.

For this example:

$$\text{total number of points} = 5 \text{ points/decade} \times 2.78 \text{ decades}$$

$$\text{total number of points} = 13.89 \text{ points}$$

Therefore, the total number of points equals 14 points.

3. Compute the frequency points using the frequency point formula. Use the result from step 2 to calculate the point numbers. Start from $n=0$ (start frequency) and continue to $n = \text{last point}$ (stop frequency). Note that the stop frequency always equals the programmed stop frequency which can differ from the computed value.

For this example, the frequency points are computed and listed in the table below.

Point Number (n)	Computed Frequency $f = 50 \text{ Hz} \times 10^{n/5}$	Point Number (n)	Computed Frequency $f = 50 \text{ Hz} \times 10^{n/5}$
0	50.000 Hz	8	1990.5 Hz
1	79.245 Hz	9	3154.8 Hz
2	125.59 Hz	10	5000.0 Hz
3	199.05 Hz	11	7924.5 Hz
4	315.48 Hz	12	12.559 kHz
5	500.00 Hz	13	19.905 kHz
6	792.45 Hz	14	31.548 kHz*
7	1255.9 Hz		

*For the last point in the sweep the instrument tunes to the programmed stop frequency (30 kHz) and not the computed value (31.548 kHz).

RELATED SECTIONS

Special Functions
Sweep
X-Y Recording

Time Between Measurements (Special Function 14)

DESCRIPTION

A one-second delay between measurements can be added using Special Function 14. This one-second delay is normally used when making plots with a relatively slow X-Y recorder. It can also be used to allow the device under test to settle before making the measurement.

PROCEDURE

To add or delete the one-second time delay between measurements, key in the corresponding Special Function code and then press the SPCL key.

Time Delay Between Measurements	Special Function Code	Program Code ↔ HP-IB ↔
Minimum	14.0 SPCL	14.0SP
Add 1 second	14.1 SPCL	14.1SP

EXAMPLE

To set a one second time delay between measurements:

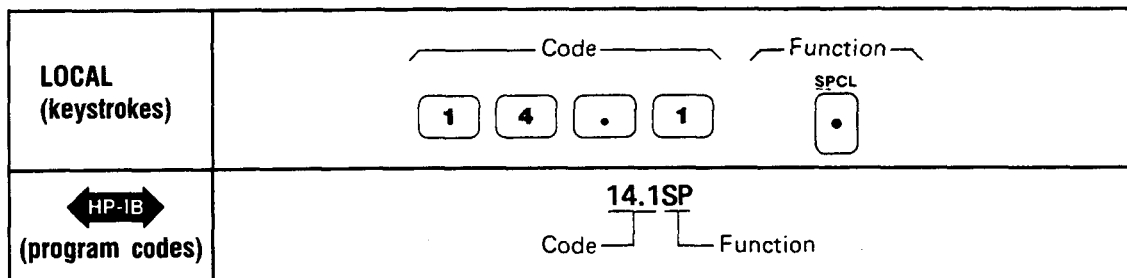

PROGRAM CODES

↔ HP-IB ↔ For HP-IB codes, refer to *Procedure* above.

INDICATIONS

As the numeric code is entered, both displays will blank and the entered code will appear in the left display. When the SPCL key is pressed, the SPCL key lights (if it is not already on). If it is on, it will remain on. Both displays then return to the display that is appropriate for the currently selected measurement mode.

RELATED SECTIONS

- Automatic Operation
- Special Functions
- X-Y Recording

X-Y Recording

DESCRIPTION

When used in conjunction with the sweep mode, any of the measurement results can be plotted as a function of frequency by connecting an X-Y recorder to the Audio Analyzer recorder outputs. The recorder outputs are X AXIS, Y AXIS, and PEN LIFT. These outputs are located on the rear panel of the instrument.

The X AXIS and Y AXIS outputs provide a voltage staircase scaled between 0 and 10 Vdc. The output impedance for both outputs is 1000Ω. X-axis scaling is determined by the programmed start and stop frequencies. The output voltage is proportional to the logarithm of the source frequency as it sweeps. The output voltage ranges from 0 Vdc for the start frequency to approximately 10 Vdc for the stop frequency. Y-axis scaling is determined by the measurement unit selected and the programmed upper and lower plot limits. The output voltage is proportional to the displayed reading. The output voltage ranges from 0 Vdc for the lower plot limit value to approximately 10 Vdc for the upper plot limit value.

The PEN LIFT output is a TTL high level for a pen-up condition and a TTL low level for a pen-down condition. During a sweep the PEN LIFT output goes low (pen-down condition) after reaching the first point, then goes high again after plotting the last point.

PROCEDURE

The following procedure describes how to use the Audio Analyzer with an X-Y recorder:

1. The figure below illustrates a typical set-up for X-Y recording. Connect the equipment as shown in the figure and select a measurement.

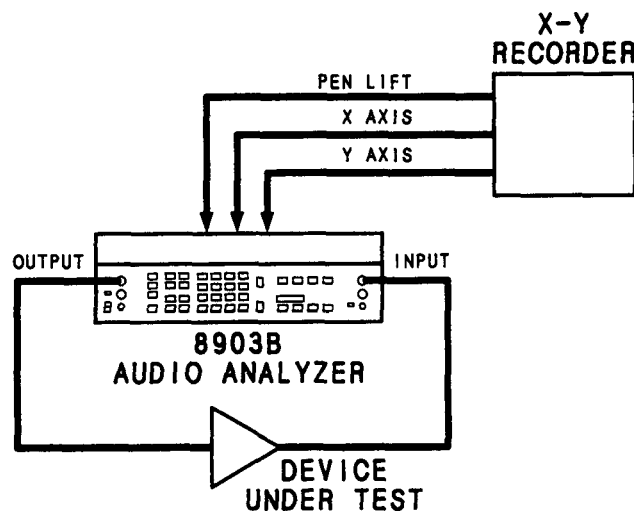

X-Y Recording Setup

2. The START FREQ and STOP FREQ keys are used to establish the two reference points needed for adjusting the X-Y recorder X and Y axes. These two references determine the plotting area or plot dimension. The START FREQ key sets both the X AXIS and Y AXIS outputs to 0 volts. This reference point corresponds to the lower left corner of the graph. To set the lower left corner point, press the START FREQ key and adjust the zero controls on the X-Y recorder to position the pen to the lower left corner of the graph. The STOP FREQ key sets both the X AXIS and Y AXIS outputs to 10 volts. This reference point corresponds to the upper right corner of the graph. To set the upper right corner point, press the STOP FREQ key and adjust the vernier controls on the X-Y recorder to position the pen to the upper right corner of the graph.

3. The Y-axis scaling unit is determined by the displayed measurement unit in the right display. Any displayed measurement unit except mV can be used when plotting. To scale the Y axis, key in the desired upper and lower plot limit.
4. The X axis corresponds to the frequency span of the Audio Analyzer source. The frequency scaling of the X axis is in logarithmic units. To scale the X axis, key in the desired start and stop frequencies. The left-most point on the X axis corresponds to the start frequency.

NOTE

No readjustment of the X-Y recorder is required if the X and Y scale factors are changed. The Audio Analyzer automatically scales both the X- and Y-axis outputs to fit in the established plot dimension.

5. To execute the plot, press the SWEEP key. The number of frequency points plotted is determined by the sweep size (the ratio of the entered start and stop frequencies) and the sweep resolution selected. The sweep resolution can be selected from 1 to 500 points per decade using Special Function 17. The maximum number of points allowable in one sweep is 255.

EXAMPLE

The following example describes how to plot the frequency response (gain vs. frequency) of a RIAA (Record Industry Association of America) phonograph preamplifier. The *Theoretical RIAA Response Curve* figure on the last page of this section is a plot of a theoretical RIAA curve. By plotting the frequency response of the phonograph amplifier on a copy of this figure, the response of the phonograph amplifier can be directly compared with the theoretical response. A table of RIAA response values is also included. (This standard is normally specified over a range 50 Hz to 15 kHz.)

RIAA Standard Response			
Frequency (Hz)	Relative Gain (dB)	Frequency (Hz)	Relative Gain (dB)
20	+19.27	800	+0.75
30	+18.59	1 000 *	0.00
40	+17.79	1 500	-1.40
50	+16.95	2 000	-2.59
60	+16.10	3 000	-4.74
80	+14.51	4 000	-6.61
100	+13.09	5 000	-8.21
150	+10.27	6 000	-9.60
200	+8.22	8 000	-11.90
300	+5.48	10 000	-13.74
400	+3.78	15 000	-17.16
500	+2.65	20 000	-19.62

*Reference frequency

1. Connect the equipment as shown in the X-Y Recording Set-up figure at the beginning of this section.
2. Place a graph paper or a copy of the RIAA curve on the X-Y recorder. (This procedure assumes that the measurement result is plotted on a copy of the RIAA curve.) Press the START FREQ key and use the zero controls on the X-Y recorder to move the pen to the lower left corner of the graph. The point where the 20 and -30 dB grid lines cross corresponds to the lower left corner. Next, press the STOP FREQ key and use the vernier controls on the X-Y recorder to move the pen to the upper right corner of the graph (the intersection of the +30 dB and 20 kHz grid lines). Press the START FREQ key again to check the lower left corner point and readjust if necessary.

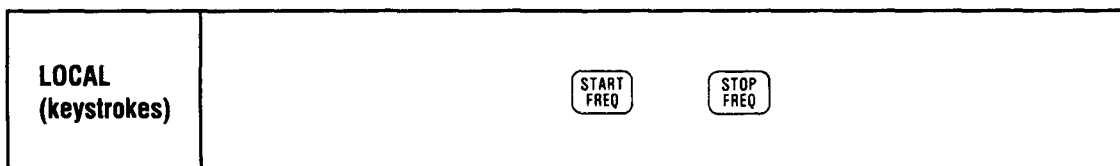

3. Set the Audio Analyzer to measure ac level.



4. Set the Audio Analyzer source to sweep from 20 Hz to 20 kHz. (The Audio Analyzer powers up with start and stop frequencies of 20 Hz and 20 kHz respectively.)

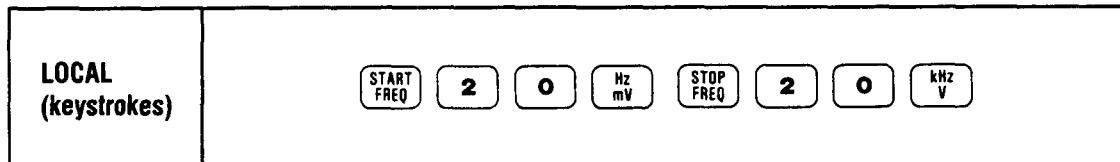

5. Set the Audio Analyzer upper and lower plot limit to +30 and -30, respectively.

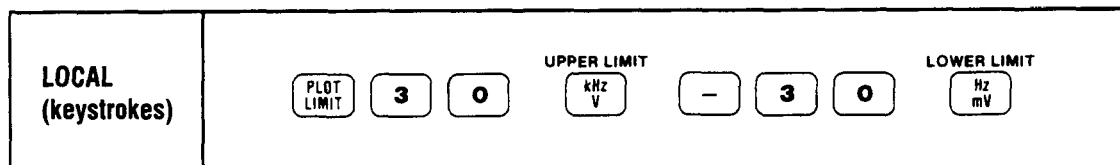

6. Select the desired sweep resolution using Special Function 17. (The Audio Analyzer powers up with the sweep resolution set at 10 points per decade.) In this example there are three decades ($\log 20000/20 = 3$) so the maximum sweep resolution allowed is 50 points per decade.

- Set the Audio Analyzer source frequency to 1 kHz and establish a ratio reference in dB to the displayed value. If the ac level is displayed in volts, press the LOG/LIN key to obtain a display in dB.

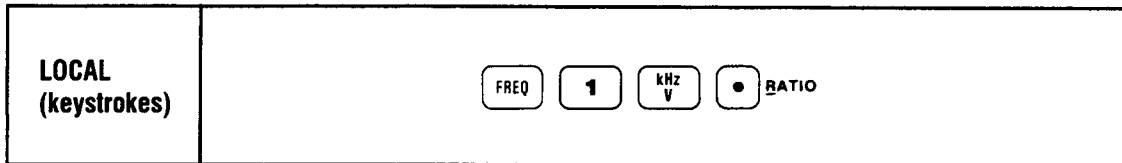

NOTE

Since the RIAA amplifier gain is much higher at 20 Hz, it is recommended that the signal source first be set to 20 Hz and the level set for less than rated output from the preamplifier.

- The graph paper is now scaled to measure ac level in dB from 20 Hz to 20 kHz. The upper plot limit is equal to +30 dB and the lower plot limit is equal to -30 dB. The level at 1 kHz is referenced to 0 dB. Press the SWEEP key to start the plot. When the plot is completed the LED within the sweep key will turn off and the PEN LIFT output will go high. (If the plot has been disabled by Special Function 13.1, enable plot by keying in 13.0 SPCL.)

PROGRAM CODES

↔ HP-IB ↔ The HP-IB codes for the above example are given below:

Key	Program Code ↔ HP-IB ↔
START FREQ	FA
STOP FREQ	FB
AC LEVEL	M1
Hz	HZ
kHz	KZ
PLOT LIMIT	PL
UPPER LIMIT	UL
LOWER LIMIT	LL
RATIO Off	R0
RATIO On	R1
LOG	LG
SWEEP	W1

COMMENTS

The X- and Y-axis outputs and the PEN LIFT output can be selectively enabled or disabled by using Special Function 13. This feature allows the user to disable the X-Y recorder during a sweep.

Some delay may be noted when pressing keys during sweep with an X-Y recorder enabled. This delay allows the pen to lift before moving on. Keys pressed during the sweep are recognized and it is not necessary to hold them down while waiting for the Audio Analyzer to respond.

If the sweep is too fast for the X-Y Recorder, a delay of 1 second can be added between points by using Special Function 14.1.

RELATED SECTIONS

AC Level
DC Level
SINAD
Signal-to-Noise
Distortion
Distortion Level
Plot Limit
Special Functions
Sweep
Sweep Resolution
Time Between Measurements

RELATIVE
GAIN (dB)

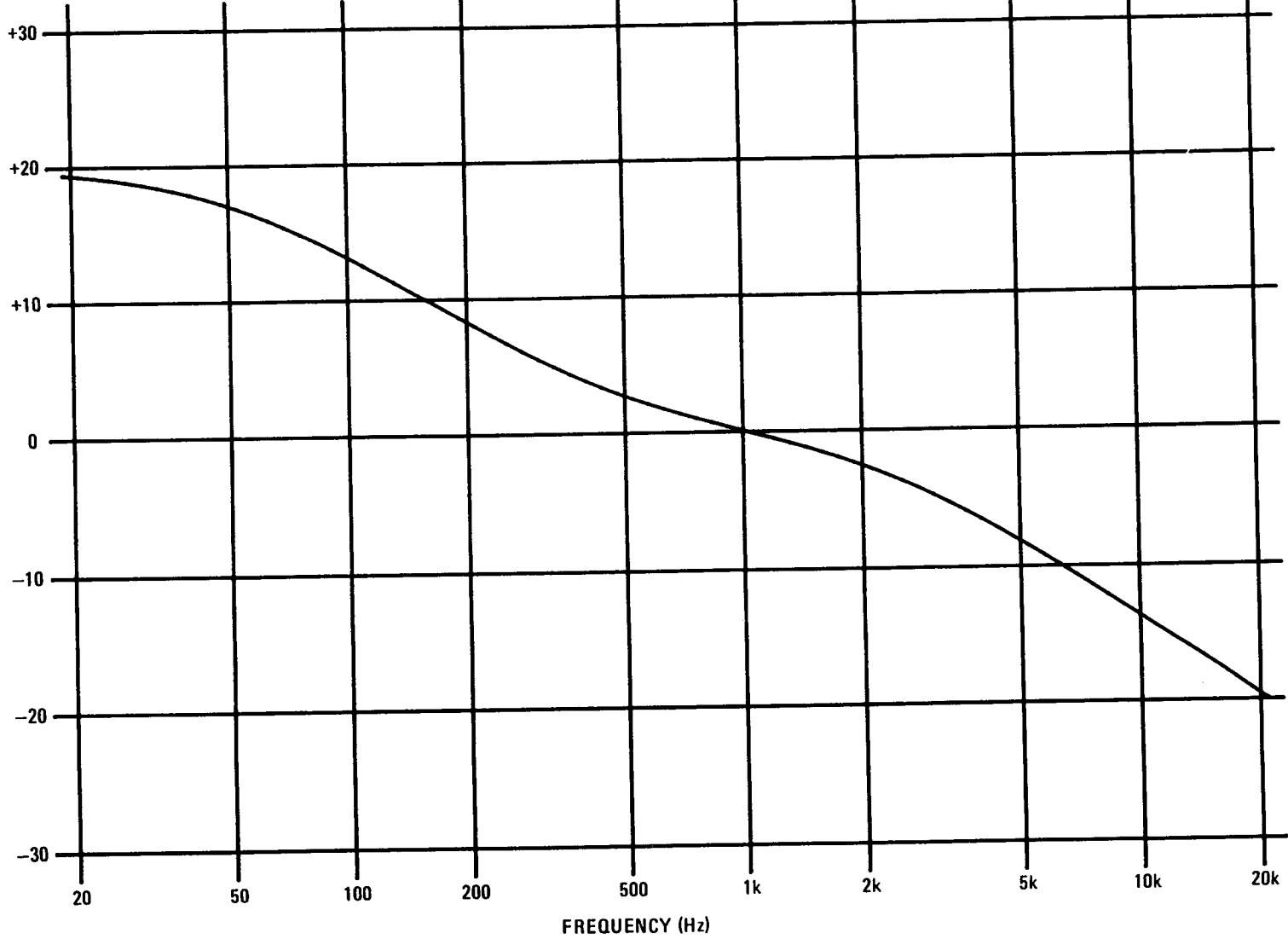

Theoretical RIAA Response Curve

Section 4

PERFORMANCE TESTS

4-1. INTRODUCTION

The procedures in this section test the instrument's electrical performance using the specifications of Table 1-1 as the performance standards. All tests can be performed without access to the interior of the instrument. A simpler operational test is included in Section 3 under *Basic Functional Checks*. The *Basic Functional Checks* also test the instrument's ability to function in the automatic mode (which is not thoroughly checked by the Performance Tests).

NOTE

Unless otherwise noted, a warm-up period of 30 minutes is required for these tests.

Line voltage must be within +5% and -10% of the specified input voltage (100, 120, 220, or 240 Vac) if the performance tests are to be considered valid.

4-2. EQUIPMENT REQUIRED

Equipment required for the performance tests is listed in Table 1-3, *Recommended Test Equipment*, in Section 1 of this manual. Any equipment that satisfies the critical specifications in the table may be substituted for the recommended model(s).

NOTE

The performance tests are based on the assumption that the recommended test equipment is used. Substituting alternate test equipment may require modification of some procedures.

4-3. TEST RECORD

Results of the performance tests may be tabulated on the Test Record shown in Table 4-1 at the end of the procedures. The Test Record lists all of the tested specifications and their acceptable limits. The results, recorded at incoming inspection, can be used for comparison in periodic maintenance and troubleshooting and after repairs or adjustments.

4-4. CALIBRATION CYCLE

This instrument requires periodic verification of performance. Depending on the use and environmental conditions, the instrument should be checked using the following performance tests at least once every year.

4-5. ABBREVIATED PERFORMANCE TESTING

No abbreviation of performance testing is recommended.

Performance Test 1

AC LEVEL ACCURACY AND OUTPUT LEVEL ACCURACY AND FLATNESS TEST

Specification

Characteristic	Performance Limits	Conditions
SOURCE		
OUTPUT LEVEL		
Accuracy	±2% of setting ±3% of setting ±5% of setting	60 mV to 6V; open circuit; 20 Hz to 50 kHz 6 mV to 6V; open circuit; 20 Hz to 100 kHz 0.6 mV to 6 mV; open circuit; 20 Hz to 100 kHz
Flatness	±0.7% (±0.06 dB) ±2.5% (±0.22 dB)	20 Hz to 20 kHz; 1 kHz reference 20 Hz to 100 kHz; 1 kHz reference
MEASUREMENT		
AC LEVEL		
Accuracy	±2% ±4% ±4%	50 mV to 300V; 20 Hz to 20 kHz 50 mV to 300V; 20 kHz to 100 kHz 0.3 mV to 50 mV; 20 Hz to 100 kHz

Description

For each ac range, ac level accuracy is determined by measuring the output of an ac calibrator. In addition, for the lowest range the output of an audio synthesizer is set to the lowest level of the just-completed calibration. This level is established as a ratio reference, then the signal is attenuated by a precise amount.

This procedure is run with the ac calibrator connected to the high input and the low input grounded, then with the ac calibrator connected to the low input and the high input grounded.

The output level accuracy and flatness of the Audio Analyzer source are determined by measuring the output of the source directly with the Audio Analyzer's voltmeter (which has just been calibrated).

WARNING

Voltages up to 300 Vrms will be applied to the Audio Analyzer's input connectors.

Equipment

AC Calibrator HP 745A and HP 746A, Datron 4200, or Fluke 5200A and Fluke 5215A
 Audio Synthesizer..... HP 3336C

Procedure

High-Level, High-Input AC Level Accuracy

1. On the Audio Analyzer, key in 41.0 SPCL to initialize the instrument. Set the INPUT and OUTPUT switches both to ground. Set the 80 kHz LOW PASS FILTER off. Connect the ac calibrator to the Audio Analyzer's HIGH INPUT.
2. On the Audio Analyzer, key in the Special Functions indicated in the table below. Set the ac calibrator to the level indicated in the table. (Use the high voltage amplifier where needed.) On the Audio Analyzer, key in the same voltage and press RATIO. Now set the ac calibrator to the frequency indicated in the table. The right display of the Audio Analyzer should read within the limits indicated.

NOTE

Record the readings in the tables. Many of the readings will be used as calibration factors in later steps.

If the ac calibrator is unable to drive the input capacitance of the Audio Analyzer and input cable at high frequencies and voltages, then reduce the level as needed.

Special Function	AC Calibrator		Ratio Limits (%)		
	Level (Vrms)	Frequency (Hz)	Minimum	Actual	Maximum
1.1	300	20	98	_____	102
		1 000	98	_____	102
		20 000	98	_____	102
		100 000	96	_____	104
1.2	150	100 000	96	_____	104
		20 000	98	_____	102
		1 000	98	_____	102
		20	98	_____	102
1.3	100	20	98	_____	102
		1 000	98	_____	102
		20 000	98	_____	102
		100 000	96	_____	104
1.4	70	100 000	96	_____	104
		20 000	98	_____	102
		1 000	98	_____	102
		20	98	_____	102
1.5	45	20	98	_____	102
		1 000	98	_____	102
		20 000	98	_____	102
		100 000	96	_____	104

Special Function	AC Calibrator		Ratio Limits (%)		
	Level (Vrms)	Frequency (Hz)	Minimum	Actual	Maximum
1.6	30	100 000	96	_____	104
		20 000	98	_____	102
		1 000	98	_____	102
		20	98	_____	102
1.7	15	20	98	_____	102
		1 000	98	_____	102
		20 000	98	_____	102
		100 000	96	_____	104
1.8	10	100 000	96	_____	104
		20 000	98	_____	102
		1 000	98	_____	102
		20	98	_____	102
1.9	7	20	98	_____	102
		1 000	98	_____	102
		20 000	98	_____	102
		50 000	96	_____	104
		100 000	96	_____	104
1.10	4.5	100 000	96	_____	104
		20 000	98	_____	102
		1 000	98	_____	102
		20	98	_____	102
1.11	3.0	20	98	_____	102
		1 000	98	_____	102
		20 000	98	_____	102
		100 000	96	_____	104
1.12	1.5	100 000	96	_____	104
		20 000	98	_____	102
		1 000	98	_____	102
		20	98	_____	102
1.13	1.0	20	98	_____	102
		1 000	98	_____	102
		20 000	98	_____	102
		100 000	96	_____	104

Special Function	AC Calibrator		Ratio Limits (%)		
	Level (Vrms)	Frequency (Hz)	Minimum	Actual	Maximum
1.14	0.7	100 000	96	_____	104
		50 000	96	_____	104
		20 000	98	_____	102
		1 000	98	_____	102
		20	98	_____	102
1.15	0.45	20	98	_____	102
		1 000	98	_____	102
		20 000	98	_____	102
		100 000	96	_____	104
1.16	0.30	100 000	96	_____	104
		20 000	98	_____	102
		1 000	98	_____	102
		20	98	_____	102
1.17	0.15	20	98	_____	102
		1 000	98	_____	102
		20 000	98	_____	102
		100 000	96	_____	104
1.18	0.10	100 000	96	_____	104
		20 000	98	_____	102
		1 000	98	_____	102
		20	98	_____	102
1.19	0.07	20	98	_____	102
		1 000	98	_____	102
		20 000	98	_____	102
		50 000	96	_____	104
		100 000	96	_____	104
	0.007	100 000	96	_____	104
		50 000	96	_____	104
		20 000	96	_____	104
		1 000	96	_____	104
		20	96	_____	104

High-Level, Low-Input AC Level Accuracy

3. Set the INPUT switch to FLOAT. Connect the output of the ac calibrator to the LOW INPUT of the Audio Analyzer. Short the HIGH INPUT to ground.
4. On the Audio Analyzer, key in the Special Functions indicated in the table below. Set the ac calibrator to the level indicated in the table. (Use the high voltage amplifier where needed.) On the Audio Analyzer, key in the same voltage and press RATIO. Now set the ac calibrator to the frequency indicated in the table. The right display of the Audio Analyzer should read within the limits indicated.

Special Function	AC Calibrator		Ratio Limits (%)		
	Level (Vrms)	Frequency (Hz)	Minimum	Actual	Maximum
1.1	300	20	98	_____	102
		1 000	98	_____	102
		20 000	98	_____	102
		100 000	96	_____	104
1.2	150	100 000	96	_____	104
		20 000	98	_____	102
		1 000	98	_____	102
		20	98	_____	102
1.3	100	20	98	_____	102
		1 000	98	_____	102
		20 000	98	_____	102
		100 000	96	_____	104
1.4	70	100 000	96	_____	104
		20 000	98	_____	102
		1 000	98	_____	102
		20	98	_____	102
1.5	45	20	98	_____	102
		1 000	98	_____	102
		20 000	98	_____	102
		100 000	96	_____	104
1.6	30	100 000	96	_____	104
		20 000	98	_____	102
		1 000	98	_____	102
		20	98	_____	102
1.7	15	20	98	_____	102
		1 000	98	_____	102
		20 000	98	_____	102
		100 000	96	_____	104

Special Function	AC Calibrator		Ratio Limits (%)		
	Level (Vrms)	Frequency (Hz)	Minimum	Actual	Maximum
1.8	10	100 000	96	_____	104
		20 000	98	_____	102
		1 000	98	_____	102
		20	98	_____	102
1.9	7	20	98	_____	102
		1 000	98	_____	102
		20 000	98	_____	102
		100 000	96	_____	104
1.10	4.5	100 000	96	_____	104
		20 000	98	_____	102
		1 000	98	_____	102
		20	98	_____	102
1.11	3.0	20	98	_____	102
		1 000	98	_____	102
		20 000	98	_____	102
		100 000	96	_____	104
1.12	1.5	100 000	96	_____	104
		20 000	98	_____	102
		1 000	98	_____	102
		20	98	_____	102
1.13	1.0	20	98	_____	102
		1 000	98	_____	102
		20 000	98	_____	102
		100 000	96	_____	104
1.14	0.7	100 000	96	_____	104
		20 000	98	_____	102
		1 000	98	_____	102
		20	98	_____	102
1.15	0.45	20	98	_____	102
		1 000	98	_____	102
		20 000	98	_____	102
		100 000	96	_____	104
1.16	0.30	100 000	96	_____	104
		20 000	98	_____	102
		1 000	98	_____	102
		20	98	_____	102

Special Function	AC Calibrator		Ratio Limits (%)		
	Level (Vrms)	Frequency (Hz)	Minimum	Actual	Maximum
1.17	0.15	20	98	_____	102
		1 000	98	_____	102
		20 000	98	_____	102
		100 000	96	_____	104
1.18	0.10	100 000	96	_____	104
		20 000	98	_____	102
		1 000	98	_____	102
		20	98	_____	102
1.19	0.07	20	98	_____	102
		1 000	98	_____	102
		20 000	98	_____	102
		100 000	96	_____	104
	0.007	100 000	96	_____	104
		20 000	96	_____	104
		1 000	96	_____	104
		20	96	_____	104

Low-Level, Low-Input AC Level Accuracy

5. Replace the ac calibrator with the audio synthesizer. (Leave the HIGH INPUT shorted to ground.) Set the audio synthesizer's level to approximately 7 mV(rms) as read on the Audio Analyzer.
6. Set the audio synthesizer to the frequency indicated in the table below. For each setting, perform the following procedure:
 - a. Press RATIO if it is on. Set the audio synthesizer to 7 mV(rms) as read on the Audio Analyzer. Press RATIO.
 - b. Decrease the level of the audio synthesizer by exactly 26 dB. Note the reading of the right display of the Audio Analyzer.
 - c. Multiply the reading on the right display by the entry in the table of step 4 which corresponds to the ac calibrator setting of 0.007 Vrms at the current frequency. Divide the result by 5.01. The computed ratio should be within the limits indicated below. For example, if the reading in step b was 5.03% and the corresponding reading of step 4 is 101.5%, the computed result is

$$\frac{5.03\% \times 101.5\%}{5.01\%} = 101.9\%$$

Synthesizer Frequency (Hz)	Displayed Reading of Step b (%)	Limits of Computed Result (%)		
		Minimum	Actual	Maximum
20	_____	96	_____	104
1 000	_____	96	_____	104
20 000	_____	96	_____	104
100 000	_____	96	_____	104

Low-Level, High-Input AC Level Accuracy

7. Remove the short from the Audio Analyzer's INPUT. Connect the audio synthesizer's output directly to the Audio Analyzer. Set the Audio Analyzer's INPUT switch to ground.
8. Set the audio synthesizer to the frequency indicated in the table below. For each setting, perform the following procedure:
 - a. Press RATIO if it is on. Set the audio synthesizer to 7 mV(rms) as read on the Audio Analyzer. Press RATIO.
 - b. Decrease the level of the audio synthesizer by exactly 26 dB. Note the reading of the right display of the Audio Analyzer.
 - c. Multiply the reading on the right display by the entry in the table of step 2 which corresponds to the ac calibrator setting of 0.007 Vrms at the current frequency. Divide the result by 5.01.

Synthesizer Frequency (Hz)	Displayed Reading of Step b (%)	Limits of Computed Result (%)		
		Minimum	Actual	Maximum
100 000	_____	96	_____	104
20 000	_____	96	_____	104
1 000	_____	96	_____	104
20	_____	96	_____	104

Output Level Accuracy

9. Disconnect the audio synthesizer. Connect the HIGH OUTPUT to the HIGH INPUT. Key in 47.1 SPCL to set the Source impedance to 50Ω.
10. On the Audio Analyzer, key in the special function, source amplitude, and source frequency listed in the table below. For each setting perform the following procedure:
 - a. Key in the source amplitude (listed in the table) as a ratio reference and press RATIO.
 - b. Divide the displayed ratio by the result of step 2 corresponding to the same amplitude and frequency then multiply by 100. The computed result should be within the limits indicated.

Special Function	SOURCE		Limits of Computed Results (%)		
	Amplitude (V)	Frequency (Hz)	Minimum	Actual	Maximum
1.9	6*	20	98	_____	102
		1 000	98	_____	102
		20 000	98	_____	102
		50 000	98	_____	102
		100 000	97	_____	103
1.14	0.7	100 000	97	_____	103
		50 000	98	_____	102
		20 000	98	_____	102
		1 000	98	_____	102
		20	98	_____	102
1.19	0.07	20	98	_____	102
		1 000	98	_____	102
		20 000	98	_____	102
		50 000	98	_____	102
		100 000	97	_____	103
	0.007	100 000	97	_____	103
		20 000	98	_____	102
		1 000	98	_____	102
		20	98	_____	102
			98	_____	102

* Use the results for 7 Vrms in step 2.

- On the Audio Analyzer, set the source amplitude to 0.7 mV. Key in 0.0007 RATIO. Set the source frequency as listed in the table below. For each entry, divide the displayed result by the result of step 8 corresponding to the same frequency then multiply by 100. The computed result should be within the limits indicated.

SOURCE Frequency (Hz)	Limits of Computed Results (%)		
	Minimum	Actual	Maximum
20	95	_____	105
1 000	95	_____	105
20 000	95	_____	105
100 000	95	_____	105

Output Level Flatness

- For the readings of steps 10 and 11, for each source amplitude setting, subtract the readings for each frequency from the reading for 1000 Hz. Ignoring the sign, the difference should be within the limits given below.

Amplitude (V)	Frequency (Hz)	Difference (%)	
		Actual	Maximum
6	20	_____	0.7
	20 000	_____	0.7
	50 000	_____	2.5
	100 000	_____	2.5
0.7	20	_____	0.7
	20 000	_____	0.7
	50 000	_____	2.5
	100 000	_____	2.5
0.07	20	_____	0.7
	20 000	_____	0.7
	50 000	_____	2.5
	100 000	_____	2.5
0.007	20	_____	0.7
	20 000	_____	0.7
	100 000	_____	2.5

Performance Test 2

DC LEVEL ACCURACY PERFORMANCE TEST

Specification

Characteristic	Performance Limits	Conditions
MEASUREMENT		
DC LEVEL		
Accuracy	±1% of reading ±6 mV	600 mV to 300V <600 mV

Description

The output from a dc standard is applied to the input of the Audio Analyzer and the voltage on the display is compared against the output from the standard. This procedure is run with the dc standard connected to the high input and the low input grounded, then with the dc standard connected to the low input and the high input grounded.

WARNING

Voltages up to 300 Vdc will be applied to the Audio Analyzer's input connectors.

Equipment

DC Standard HP 740B, Datron 4000, or Fluke 893AR

Procedure

High-Input DC Level Accuracy

1. On the Audio Analyzer, key in 41.0 SPCL to initialize the instrument. Set the INPUT switch to ground. Press S (Shift) DC LEVEL.
2. Connect the output of the dc standard to the HIGH INPUT of the Audio Analyzer.
3. Set the dc standard to give the output voltage indicated below. For each setting, the right display on the Audio Analyzer should read within the limits indicated.

DC Standard Voltage (Vdc)	DC Voltage Limits (Vdc)		
	Minimum	Actual	Maximum
300	297	_____	303
30	29.7	_____	30.3
3	2.97	_____	3.03
0.6	0.594	_____	0.606
0.06	0.054	_____	0.066

Low-Input DC Level Accuracy

4. Set the INPUT switch to FLOAT. Connect the output of the dc standard to the LOW INPUT of the Audio Analyzer. Short the HIGH INPUT to ground.
5. Set the dc standard to give the output voltage indicated below. For each setting, the right display on the Audio Analyzer should read within the limits indicated.

DC Standard Voltage (Vdc)	DC Voltage Limits (Vdc)		
	Minimum	Actual	Maximum
0.06	-0.066	_____	-0.054
0.6	-0.606	_____	-0.594
3	-3.03	_____	-2.97
30	-30.3	_____	-29.7
300	-303	_____	-297

Performance Test 3

DISTORTION AND NOISE PERFORMANCE TEST

Specification

Characteristic	Performance Limits	Conditions
SYSTEM		Source and analyzer combined
DISTORTION		
Residual Noise and Distortion	The higher of -80 dB or 17 μ V The higher of -70 dB or 50 μ V The higher of -65 dB or 50 μ V	20 Hz to 20 kHz; 80 kHz bandwidth 20 Hz to 50 kHz; 500 kHz bandwidth 50 kHz to 100 kHz; 500 kHz bandwidth
SIGNAL-TO-NOISE		
Residual Noise	The higher of -85 dB or 17 μ V The higher of -70 dB or 50 μ V	80 kHz bandwidth 500 kHz bandwidth
SOURCE		
OUTPUT LEVEL		
Residual Noise and Distortion	The higher of -80 dB or 15 μ V The higher of -70 dB or 38 μ V The higher of -65 dB or 38 μ V	20 Hz to 20 kHz; 80 kHz bandwidth 20 Hz to 50 kHz; 500 kHz bandwidth 50 kHz to 100 kHz; 500 kHz bandwidth
MEASUREMENT		
DISTORTION AND SINAD		
Residual Noise and Distortion	The higher of -80 dB or 15 μ V The higher of -70 dB or 45 μ V The higher of -65 dB or 45 μ V	20 Hz to 20 kHz; 80 kHz bandwidth 20 Hz to 50 kHz; 500 kHz bandwidth 50 kHz to 100 kHz; 500 kHz bandwidth

Description

The output of the Audio Analyzer is connected to its input, and the combination of distortion and noise is measured at various frequencies and levels. The test measures the distortion and noise of the instrument as a system (that is, of the source and analyzer combined) but compares performance to the individual specifications, which are tighter. If either the source or the analyzer is out of specification, a known good source or analyzer can be substituted to determine which part of the instrument is not within specification.

Equipment

Feedthrough Termination, 50 Ω HP 11048C

Procedure

1. Key in 41.0 SPCL to initialize the instrument. Set the INPUT and OUTPUT switches both to ground. Key in 47.1 SPCL to set the Source impedance to 50 Ω . Connect the HIGH OUTPUT to the HIGH INPUT through a 50 Ω feedthrough termination.

2. Set the SOURCE frequency and amplitude and the MEASUREMENT mode and LP FILTER as indicated below. For each setting, the right display should be within the limits indicated. (For the DISTN measurement set LOG LIN to read in dB.)

SOURCE		MEASUREMENT		Limits (dB)		
FREQ (Hz)	AMPTD (V)	Mode	LP FILTER	Minimum	Actual	Maximum
20	6.0	DISTN	80 kHz		_____	-80
1 000	6.0	DISTN	80 kHz		_____	-80
1 000	5.0	DISTN	80 kHz		_____	-80
1 000	3.8	DISTN	80 kHz		_____	-80
1 000	0.6	DISTN	80 kHz		_____	-80
1 000	0.6	SIG/NOISE	80 kHz	+85	_____	
20 000	6.0	DISTN	80 kHz		_____	-80
50 000	6.0	DISTN	Off		_____	-70
50 000	0.6	DISTN	Off		_____	-70
50 000	0.6	SIG/NOISE	Off	+70	_____	
100 000	6.0	DISTN	Off		_____	-65
100 000	5.0	DISTN	Off		_____	-65
100 000	3.8	DISTN	Off		_____	-65

Performance Test 4

DISTORTION, SINAD, AND SIGNAL-TO-NOISE ACCURACY PERFORMANCE TEST

Specification

Characteristic	Performance Limits	Conditions
SYSTEM		
SIGNAL-TO-NOISE		
Accuracy	± 1 dB	50 Hz to 100 kHz
MEASUREMENT		
DISTORTION		
Accuracy	± 1 dB ± 2 dB	20 Hz to 20 kHz 20 kHz to 100 kHz
SINAD		
Accuracy	± 1 dB ± 2 dB	20 Hz to 20 kHz 20 kHz to 100 kHz

Description

A signal with a known distortion level is artificially created by summing the output from the Audio Analyzer and the output from the Multifunction Synthesizer into the input of the Audio Analyzer. The artificial distortion (or noise) is measured by the Audio Analyzer. An external 20 dB attenuator is used to extend the dynamic range of the Multifunction Synthesizer output level.

Equipment

Multifunction Synthesizer HP 8904A
 20 dB Fixed Attenuator (50Ω) Texscan FP-50[20dB] or equivalent

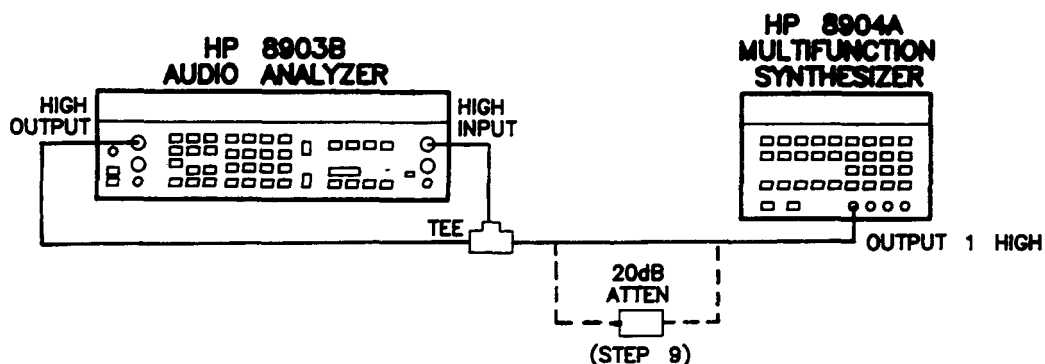

Figure 4-1. Distortion, SINAD, and Signal-to-Noise Accuracy Test Setup

Procedure

NOTE

Do NOT insert the 20 dB attenuator between the output of the Multifunction Synthesizer and the input of the Audio Analyzer until Step 9.

1. Connect the equipment as shown in Figure 4-1.
2. On the Multifunction Synthesizer, press SHIFT PRESET. After the instrument presets, key in:
 f1 (Channel Config.)
 NEXT (Channel A)
 SHIFT FLOAT 1 OFF
 AMPTD 0 V
3. On the Audio Analyzer, key in 41.0 SPCL to initialize the instrument. Set the Audio Analyzer as follows:

NOTE

To select 50Ω source impedance for Audio Analyzers with Serial Prefix 2742A and above, key in 47.1 SPCL.

OUTPUT switch ground
 INPUT switch ground
 OUTPUT IMPEDANCE (See note above) 50Ω
 SOURCE AMPTD 6V
 LOG/LIN..... LOG

4. On the Audio Analyzer, press RATIO. The right display should indicate 0.00 dB.
5. On the Audio Analyzer, set the AMPTD to 0 V.
6. On the Multifunction Synthesizer, set the AMPTD to 8.5 V. Adjust the amplitude of the Multifunction Synthesizer for a reading of 0.00 dB on the Audio Analyzer. Record the Multifunction Synthesizer AMPTD setting as V_{ref} .

V_{ref} : _____ mV

7. Use the recorded value of V_{ref} and the following formula to calculate the Multifunction Synthesizer amplitude **Amptd (mV)**. The calculations using **Atten (dB) 10 - 60** are then used in Step 9. Put the results for each level of attenuation on the lines provided below:

$$\text{Multifunction Synthesizer AMPTD} = V_{ref} \times 10^{-\left(\frac{\text{Atten}}{20}\right)}$$

Multifunction Synthesizer

Atten (dB)	Amptd (mV)
10	_____
20	_____
30	_____
40	_____
50	_____
60	_____

8. Set the Audio Analyzer as follows:

MEASUREMENT mode DIST
 LOG/LIN LOG
 SOURCE AMPTD 6V

9. Repetitively complete the following instructions for each measurement and record the results for the **Actual** limits in the following table:

- a. Set the Multifunction Synthesizer frequency to the value shown in the **Freq (Hz)** column.
- b. Set the Multifunction Synthesizer amplitude to the calculated value from step 7 for each level of attenuation shown in the **Atten (dB)** column.
- c. Insert (**IN**) or remove (**OUT**) the external attenuator as indicated.
- d. Set the Audio Analyzer frequency to the value shown in the **Freq (Hz)** column.
- e. Set the Audio Analyzer to the function indicated in the **Measurement Mode** column.
- f. Record the measurement.

Multifunction Synthesizer		External 20 dB Atten	Audio Analyzer		Limits (dB)		
Freq (Hz)	Atten (dB)		Freq (Hz)	Measurement Mode	Minimum	Actual	Maximum
100	10	OUT	25	DISTN	-11.4	_____	-9.4
100	10	OUT	25	SINAD	+9.4	_____	+11.4
100	60	IN	25	SINAD	+79.0	_____	+81.0
100	60	IN	25	DISTN	-81.0	_____	-79.0
100	60	IN	50	SIG/NOISE	+79.0	_____	+81.0
100	10	OUT	50	SIG/NOISE	+9.4	_____	+11.4
4 020	10	OUT	2 000	DISTN	-11.4	_____	-9.4
4 020	20	OUT	2 000	DISTN	-21.0	_____	-19.0
4 020	30	OUT	2 000	DISTN	-31.0	_____	-29.0
4 020	40	OUT	2 000	DISTN	-41.0	_____	-39.0
4 020	50	OUT	2 000	DISTN	-51.0	_____	-49.0
4 020	60	OUT	2 000	DISTN	-61.0	_____	-59.0
4 020	50	IN	2 000	DISTN	-71.0	_____	-69.0
4 020	60	IN	2 000	DISTN	-81.0	_____	-79.0
6 030	60	IN	2 000	DISTN	-81.0	_____	-79.0
6 030	10	OUT	2 000	DISTN	-11.4	_____	-9.4
8 040	10	OUT	2 000	DISTN	-11.4	_____	-9.4
8 040	60	IN	2 000	DISTN	-81.0	_____	-79.0
10 050	60	IN	2 000	DISTN	-81.0	_____	-79.0
10 050	10	OUT	2 000	DISTN	-11.4	_____	-9.4
40 200	10	OUT	20 000*	DISTN	-11.4	_____	-9.4
40 200	10	OUT	20 000	SINAD	+9.4	_____	+11.4
40 200	10	OUT	20 000	SIG/NOISE	+9.4	_____	+11.4
40 200	60	IN	20 000	SIG/NOISE	+79.0	_____	+81.0
40 200	60	IN	20 000	SINAD	+79.0	_____	+81.0
40 200	60	IN	20 000	DISTN	-81.0	_____	-79.0

10. On the Audio Analyzer, set the 80 kHz LOW PASS FILTER off. Repeat the previous step for the settings indicated below.

Multifunction Synthesizer		External 20 dB Atten	Audio Analyzer		Limits (dB)		
Freq (Hz)	Atten (dB)		Freq (Hz)	Measurement Mode	Minimum	Actual	Maximum
201 000	10	OUT	100 000	DISTN	-12.4	_____	-8.4
201 000	10	OUT	100 000	SINAD	+8.4	_____	+12.4
201 000	60	OUT	100 000	SINAD	+58.0	_____	+62.0
201 000	60	OUT	100 000	DISTN	-62.0	_____	-58.0
301 500	60	OUT	100 000	DISTN	-62.0	_____	-58.0
301 500	60	OUT	100 000	SINAD	+58.0	_____	+62.0
301 500	10	OUT	100 000	SINAD	+8.4	_____	+12.4
301 500	10	OUT	100 000	DISTN	-12.4	_____	-8.4

Performance Test 5

FREQUENCY ACCURACY AND SENSITIVITY PERFORMANCE TEST

Specification

Characteristic	Performance Limits	Conditions
SOURCE FREQUENCY Accuracy	$\pm 0.3\%$ of setting	
MEASUREMENT FREQUENCY Measurement Range Accuracy Sensitivity	20 Hz to 150 kHz 20 Hz to 100 kHz $\pm 0.004\% \pm 1$ digit 50 mV 5 mV	AC level mode Distortion, SINAD, and signal-to-noise modes Distortion and SINAD modes AC level and signal-to-noise modes

Description

The frequency of an audio synthesizer is measured at various levels with the Audio Analyzer's counter. After verification of the counter accuracy, the frequency of the internal audio source is then verified by the counter.

Equipment

Audio Synthesizer..... HP 3336C

NOTE

The audio synthesizer's time base accuracy must be 4 ppm or better.

Procedure

1. On the Audio Analyzer, key in 41.0 SPCL to initialize the instrument. Set the INPUT and OUTPUT switches to ground. Set AMPTD to 1V and set the 80 kHz LOW PASS FILTER off.
2. Connect the audio synthesizer's output to the Audio Analyzer's HIGH INPUT.
3. Set the audio synthesizer frequency and level (open circuit) as indicated below. For each setting, the Audio Analyzer's left display should agree with the frequency setting of the synthesizer to within the limits indicated. (If needed, the synthesizer level can be checked with the Audio Analyzer in its ac level mode.)

Audio Synthesizer		MEASUREMENT Mode	Frequency Limits (Hz)		
Frequency (Hz)	Level (mV)		Minimum	Actual	Maximum
20	5	AC LEVEL	19.99	_____	20.01
20	50	DISTN	19.99	_____	20.01
99 900	50	DISTN	99 895	_____	99 905
99 900	5	AC LEVEL	99 895	_____	99 905
150 000	5	AC LEVEL	149 980	_____	150 020

4. Connect the HIGH OUTPUT to the HIGH INPUT (in place of the audio synthesizer).
5. Key the SOURCE frequencies into the Audio Synthesizer listed in the following table. For each setting the Audio Analyzer's left display should read within the limits indicated.

SOURCE Frequency (Hz)	Frequency Limits (Hz)		
	Minimum	Actual	Maximum
20	19.94	_____	20.06
200	199.4	_____	200.6
2 000	1 994	_____	2 006
20 000	19 940	_____	20 060
100 000	99 700	_____	100 300

Performance Test 6

AUDIO FILTERS PERFORMANCE TEST

Specification

Characteristic	Performance Limits	Conditions
MEASUREMENT		
AUDIO FILTERS		
30 kHz Low-Pass Filter 3 dB Cutoff Frequency	30 kHz \pm 2 kHz	
80 kHz Low-Pass Filter 3 dB Cutoff Frequency	80 kHz \pm 4 kHz	
400 Hz High-pass Filter (Option 010 or 050) 3 dB Cutoff Frequency	400 Hz \pm 40 Hz	
CCITT Weighting Filter (Option 011 or 051) Deviation from Ideal Response ¹	\pm 0.2 dB \pm 1.0 dB \pm 2.0 dB \pm 3.0 dB	at 800 Hz 300 Hz to 3 kHz 50 Hz to 300 Hz, 3 kHz to 3.5 kHz 3.5 kHz to 5 kHz
CCIR Weighting Filter (Option 012 or 052) Deviation from Ideal Response ²	\pm 2.0 dB \pm 1.4 dB \pm 1.0 dB \pm 0.85 dB \pm 0.7 dB \pm 0.55 dB \pm 0.5 dB \pm 0.2 dB \pm 0.4 dB \pm 0.6 dB \pm 0.8 dB \pm 1.2 dB \pm 1.65 dB \pm 2.0 dB +2.8/-inf dB	31.5 Hz to 63 Hz 63 Hz to 100 Hz 100 Hz to 200 Hz 200 Hz to 400 Hz 400 Hz to 800 Hz 800 Hz to 1 kHz 1 kHz to 6.3 kHz 6.3 kHz to 8 kHz 8 kHz to 9 kHz 9 kHz to 10 kHz 10 kHz to 12.5 kHz 12.5 kHz to 14 kHz 16 kHz to 20 kHz 20 kHz to 31.5 kHz at 31.5 kHz
¹ See the International Telegraph and Telephone Consultative Committee (CCITT), Fifth Plenary Assembly, 1972, Telephone Transmission Quality, The International Telecommunication Union (1973), pp. 87-91. (CCITT Recommendation P53.) ² See the International Radio Consultative Committee (CCIR), Recommendations and Reports of the CCIR, 1978, Vol. X, pp. 162-163. (CCIR recommendation 409-3.)		

Characteristic	Performance Limits	Conditions	
C-Message Weighting Filter (Option 013 or 053) Deviation from Ideal Response ³	±2.0 dB	60 Hz to 300 Hz	
	±1.0 dB	300 Hz to 3 kHz	
	±0.2 dB	at 1 kHz	
	±2.0 dB	3 kHz to 3.5 kHz	
	±3.0 dB	3.5 kHz to 5 kHz	
	CCIR/ARM Weighting Filter (Option 014 or 054) Deviation from Ideal Response ⁴	±2.0 dB	31.5 Hz to 63 Hz
		±1.4 dB	63 Hz to 100 Hz
		±1.0 dB	100 Hz to 200 Hz
		±0.85 dB	200 Hz to 400 Hz
		±0.7 dB	400 Hz to 800 Hz
±0.55 dB		800 Hz to 1 kHz	
±0.5 dB		1 kHz to 6.3 kHz	
±0.2 dB		6.3 kHz to 8 kHz	
±0.4 dB		8 kHz to 9 kHz	
±0.6 dB		9 kHz to 10 kHz	
±0.8 dB		10 kHz to 12.5 kHz	
±1.2 dB		12.5 kHz to 14 kHz	
±1.65 dB		16 kHz to 20 kHz	
±2.0 dB	20 kHz to 31.5 kHz		
+2.8/-infdB	at 31.5 kHz		
"A" Weighting Filter (Option 015 or 055) Deviation from Ideal Response ⁵	±2.5 dB	20 Hz to 25 Hz	
	±2.0 dB	25 Hz to 31.5 Hz	
	±1.5 dB	31.5 Hz to 50 Hz	
	±1.0 dB	50 Hz to 4 kHz	
	+1.5/-2.0dB	4 kHz to 6.3 kHz	
	+1.5/-3.0dB	6.3 kHz to 8 kHz	
	+2.0/-4.0dB	8 kHz to 10 kHz	
	+3.0/-6.0dB	10 kHz to 12.5 kHz	
	+3.0/-infdB	12.5 kHz to 26 kHz	

³ See the Bell System Technical Reference 41009, May 1975.
⁴ See Dolby Laboratories Inc., Engineering Field Bulletin No. 19/4.
⁵ See the American National Standard Specification for Sound Level Meters, 1971, pp. 8-10. (American National Standard S1.4-1971.)

Description

The output of the Audio Analyzer is connected to the input. At various frequencies the ac level of the output is measured with the audio filters in and out. The ratio of the two levels is the frequency response of the filter at that frequency.

Procedure

1. Key in 41.0 SPCL to initialize the instrument. Set the INPUT and OUTPUT switches both to ground. Connect the HIGH OUTPUT to the HIGH INPUT. Set AMPTD to 2V and LOG/LIN to LOG.
2. Set the SOURCE frequency as indicated below. For each setting, perform the following procedure:
 - a. Set all filters off. Set RATIO off.
 - b. Set RATIO on. Set in the filter indicated below.
 - c. Note the dB ratio. If it is not between -3.1 and -2.9 dB, increment or decrement the SOURCE frequency slightly until the indicated level is correct. The displayed frequency should be within the limits indicated.

Initial SOURCE Frequency Setting (Hz)	High-Pass or Low-Pass Filter	Frequency Limits (Hz)		
		Minimum	Actual	Maximum
400*	400 Hz HP	360	_____	440
30 000	30 kHz LP	28 000	_____	32 000
80 000	80 kHz LP	76 000	_____	84 000
* Option 010 or 050.				

3. Key in 48.1 SPCL to enable up-ranging of the gain following the filters. Set the SOURCE frequency as indicated below in the table appropriate for the installed weighting filter. For each setting, perform the following procedure:
 - a. Set all filters off. Set RATIO off.
 - b. Set RATIO on. Select the appropriate weighting filter. The displayed ratio should be within the limits indicated.

Table for CCITT Weighting Filter (Option 011 or 051)

SOURCE Frequency (Hz)	Ratio Limits (dB)		
	Minimum	Actual	Maximum
50	-65.0	_____	-61.0
100	-43.0	_____	-39.0
200	-23.0	_____	-19.0
300	-11.6	_____	-9.6
500	-4.6	_____	-2.6
800	-0.2	_____	+0.2
1000	0.0	_____	+2.0
2000	-4.0	_____	-2.0
3000	-6.6	_____	-4.6
3500	-10.5	_____	-6.5
5000	-39.0	_____	-33.0

Table for CCIR Weighting Filter (Option 012 or 052)

SOURCE Frequency (Hz)	Ratio Limits (dB)		
	Minimum	Actual	Maximum
31.5	-31.9	_____	-27.9
63	-25.3	_____	-22.5
100	-20.8	_____	-18.8
200	-14.65	_____	-12.95
400	-8.5	_____	-7.1
800	-2.45	_____	-1.35
1 000	-0.5	_____	+0.5
2 000	+5.1	_____	+6.1
3 150	+8.5	_____	+9.5
4 000	+10.0	_____	+11.0
5 000	+11.2	_____	+12.2
6 300	+12.0	_____	+12.4
7 100	+11.8	_____	+12.2
8 000	+11.0	_____	+11.8
9 000	+9.5	_____	+10.7
10 000	+7.3	_____	+8.9
12 500	-1.2	_____	+1.2
14 000	-6.7	_____	-3.9
16 000	-13.35	_____	-10.05
20 000	-24.2	_____	-20.2
31 500	$-\infty$	_____	-39.9

Table for C-Message Weighting Filter (Option 013 or 053)

SOURCE Frequency (Hz)	Ratio Limits (dB)		
	Minimum	Actual	Maximum
60	-57.7	_____	-53.7
100	-44.5	_____	-40.5
200	-27.0	_____	-23.0
300	-17.5	_____	-15.5
400	-12.4	_____	-10.4
500	-8.5	_____	-6.5
600	-5.7	_____	-3.7
700	-3.7	_____	-1.7
800	-2.5	_____	-0.5
900	-1.6	_____	+0.4
1000	-0.2	_____	+0.2
1200	-1.2	_____	+0.8
1300	-1.5	_____	+0.5
1500	-2.0	_____	0.0
1800	-2.3	_____	-0.3
2000	-2.3	_____	-0.3
2500	-2.4	_____	-0.4
2800	-2.9	_____	-0.9
3000	-3.5	_____	-1.5
3300	-7.2	_____	-3.2
3500	-9.6	_____	-5.6
4000	-17.5	_____	-11.5
4500	-24.5	_____	-18.5
5000	-31.5	_____	-25.5

Table for CCIR/ARM Weighting Filter (Option 014 or 054)

SOURCE Frequency (Hz)	Ratio Limits (dB)		
	Minimum	Actual	Maximum
31.5	-37.5	_____	-33.5
63	-30.9	_____	-28.1
100	-26.4	_____	-24.4
200	-20.25	_____	-18.55
400	-14.1	_____	-12.7
800	-8.05	_____	-6.95
1 000	-6.1	_____	-5.1
2 000	-0.5	_____	+0.5
3 150	+2.9	_____	+3.9
4 000	+4.4	_____	+5.4
5 000	+5.6	_____	+6.6
6 300	+6.4	_____	+6.8
7 100	+6.2	_____	+6.6
8 000	+5.4	_____	+6.2
9 000	+3.9	_____	+5.1
10 000	+1.7	_____	+3.3
12 500	-6.8	_____	-4.4
14 000	-12.3	_____	-9.5
16 000	-18.95	_____	-15.65
20 000	-29.8	_____	-25.8
31 500	-∞	_____	-45.5

Table for "A" Weighting Filter (Option 015 or 055)

SOURCE Frequency (Hz)	Ratio Limits (dB)		
	Minimum	Actual	Maximum
20	-53.0	_____	-48.0
25	-46.7	_____	-42.7
31.5	-40.9	_____	-37.9
40	-36.1	_____	-33.1
50	-31.2	_____	-29.2
63	-27.2	_____	-25.2
80	-23.5	_____	-21.5
100	-20.1	_____	-18.1
125	-17.1	_____	-15.1
160	-14.4	_____	-12.4
200	-11.9	_____	- 9.9
250	-9.6	_____	-7.6
315	-7.6	_____	-5.6
400	-5.8	_____	-3.8
500	-4.2	_____	-2.2
630	-2.9	_____	-0.9
800	-1.8	_____	+0.2
1 000	-1.0	_____	+1.0
1 250	-0.4	_____	+1.6
1 600	+0.0	_____	+2.0
2 000	+0.2	_____	+2.2
2 500	+0.3	_____	+2.3
3 150	+0.2	_____	+2.2
4 000	+0.0	_____	+2.0
5 000	-1.5	_____	+2.0
6 300	-2.1	_____	+1.4
8 000	-4.1	_____	+0.4
10 000	-6.5	_____	-0.5
12 500	-10.3	_____	-1.3
16 000	-∞	_____	-3.3
20 000	-∞	_____	-6.3

Performance Test 7

INPUT AND OUTPUT IMPEDANCE PERFORMANCE TEST

Specification

Characteristic	Performance Limits	Conditions
SOURCE		
OUTPUT LEVEL		
Impedance	600Ω ±1% or 50Ω ±2%	
MEASUREMENT		
Input Impedance	100kΩ ±1%	Except dc level mode

Description

The Audio Analyzer's source is connected to its input and a ratio reference set. A known impedance is then added in parallel to, or series with the input. The drop in level is a measure of the output or input impedance.

Equipment

- Feedthrough Termination, 50Ω HP 11048C
- Feedthrough Termination, 600Ω HP 11095A
- Resistor, 100 kΩ HP 0698-7497

Procedure

1. On the Audio Analyzer, key in 41.0 SPCL to initialize the instrument. Key in 1.11 SPCL to set the input to the 3V level range. Set AMPTD to 3V and FREQ to 100 Hz. Set the INPUT and OUTPUT switches both to ground. (If the Source impedance is not already set to 600Ω, key in 47.0 SPCL to set impedance to 600Ω.)
2. Connect the HIGH OUTPUT to the HIGH INPUT. Press RATIO.
3. Insert the 600Ω feedthrough termination between the HIGH OUTPUT and the HIGH INPUT. The right display should read between 49.90 and 50.40%.
 Accuracy of 600Ω Output Impedance: 49.90 _____ 50.40%
4. Replace the 600Ω feedthrough termination with a 50Ω feedthrough termination. Key in 47.1 SPCL to set the Source impedance to 50Ω. The right display should read between 49.00 and 51.00%.
 Accuracy of 50Ω Output Impedance: 49.00 _____ 51.00%
5. Replace the feedthrough termination by a 100 kΩ resistor in series with the HIGH INPUT. The right display should read between 49.00 and 51.00%.
 Accuracy of High Input Impedance: 49.00 _____ 51.00%
6. Set the INPUT switch to FLOAT. Move the connection at the HIGH INPUT to the LOW INPUT. The right display should read between 49.00 and 51.00%.
 Accuracy of Low Input Impedance: 49.00 _____ 51.00%

Performance Test 8

COMMON-MODE REJECTION RATIO PERFORMANCE TEST

Specification

Characteristic	Performance Limit	Conditions
GENERAL		
Common Mode Rejection Ratio	>60 dB	Differential input <2V; 20 to 1000 Hz
	>45 dB	Differential input >2V; 20 to 1000 Hz
	>30 dB	1 to 20 kHz

Description

The output from the internal source is connected to both the high and low inputs of the Audio Analyzer. The low input is set to float. The ac level of the common-mode input is then measured for two different input ranges.

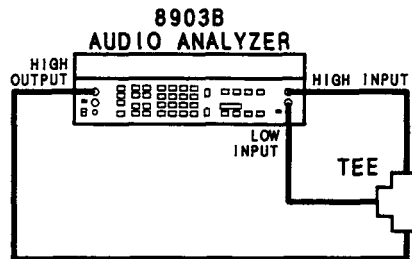

Figure 4-2. Common-Mode Rejection Ratio Test Setup

Procedure

1. On the Audio Analyzer, key in 41.0 SPCL to initialize the instrument. Set the OUTPUT switch to ground. Set the INPUT switch to FLOAT. Key in 47.0 SPCL to set the Source impedance to 600Ω. Set AMPD to 1V.
2. Connect the HIGH OUTPUT to the HIGH INPUT through the tee as shown in Figure 4-2.
3. Key in the Special Function indicated in the table below. For each setting, the right display should read within the limits indicated.

Special Function	Oscillator Frequency (Hz)	AC Level Limits (mV)	
		Actual	Maximum
1.12	20	_____	1
	1 000	_____	1
	20 000	_____	32
1.1	20 000	_____	32
	1 000	_____	5.6
	20	_____	5.6

Table 4-1. Performance Test Record (1 of 12)

Hewlett-Packard Company				Tested by: _____		
Model 8903B						
Audio Analyzer				Date _____		
Serial Number _____						
Test No.	Test Description			Results		
				Minimum	Actual	Maximum
1	AC LEVEL ACCURACY AND OUTPUT LEVEL ACCURACY AND FLATNESS PERFORMANCE TEST					
	High-Level, High-Input AC Level Accuracy					
		AC Calibrator				
	Special Function	Level (Vrms)	Frequency (Hz)			
	1.1	300	20	98%	_____	102%
			1 000	98%	_____	102%
			20 000	98%	_____	102%
			100 000	96%	_____	104%
	1.2	150	100 000	96%	_____	104%
			20 000	98%	_____	102%
			1 000	98%	_____	102%
			20	98%	_____	102%
	1.3	100	20	98%	_____	102%
			1 000	98%	_____	102%
			20 000	98%	_____	102%
			100 000	96%	_____	104%
	1.4	70	100 000	96%	_____	104%
			20 000	98%	_____	102%
			1 000	98%	_____	102%
			20	98%	_____	102%
	1.5	45	20	98%	_____	102%
			1 000	98%	_____	102%
			20 000	98%	_____	102%
			100 000	96%	_____	104%
	1.6	30	100 000	96%	_____	104%
			20 000	98%	_____	102%
			1 000	98%	_____	102%
			20	98%	_____	102%
	1.7	15	20	98%	_____	102%
			1 000	98%	_____	102%
			20 000	98%	_____	102%
			100 000	96%	_____	104%
	1.8	10	100 000	96%	_____	104%
			20 000	98%	_____	102%
			1 000	98%	_____	102%
			20	98%	_____	102%

Table 4-1. Performance Test Record (2 of 12)

Test No.	Test Description			Results			
				Minimum	Actual	Maximum	
1	AC LEVEL ACCURACY AND OUTPUT LEVEL ACCURACY AND FLATNESS PERFORMANCE TEST						
	High-Level, High-Input AC Level Accuracy						
		AC Calibrator					
		Special Function	Level (Vrms)	Frequency (Hz)			
		1.9	7	20	98%	_____	102%
				1 000	98%	_____	102%
				20 000	98%	_____	102%
				50 000	96%	_____	104%
				100 000	96%	_____	104%
		1.10	4.5	100 000	96%	_____	104%
				20 000	98%	_____	102%
				1 000	98%	_____	102%
				20	98%	_____	102%
		1.11	3.0	20	98%	_____	102%
				1 000	98%	_____	102%
				20 000	98%	_____	102%
				100 000	96%	_____	104%
		1.12	1.5	100 000	96%	_____	104%
				20 000	98%	_____	102%
				1 000	98%	_____	102%
				20	98%	_____	102%
		1.13	1.0	20	98%	_____	102%
				1 000	98%	_____	102%
				20 000	98%	_____	102%
	100 000			96%	_____	104%	
	1.14	0.7	100 000	96%	_____	104%	
			50 000	96%	_____	104%	
			20 000	98%	_____	102%	
			1 000	98%	_____	102%	
			20	98%	_____	102%	
	1.15	0.45	20	98%	_____	102%	
			1 000	98%	_____	102%	
			20 000	98%	_____	102%	
			100 000	96%	_____	104%	
	1.16	0.30	100 000	96%	_____	104%	
			20 000	98%	_____	102%	
			1 000	98%	_____	102%	
			20	98%	_____	102%	

Table 4-1. Performance Test Record (3 of 12)

Test No.	Test Description			Results		
				Minimum	Actual	Maximum
1	AC LEVEL ACCURACY AND OUTPUT LEVEL ACCURACY AND FLATNESS PERFORMANCE TEST					
	High-Level, High-Input AC Level Accuracy					
			AC Calibrator			
		Special Function	Level (Vrms)	Frequency (Hz)		
	1.17	0.15	20	98%	_____	102%
			1 000	98%	_____	102%
			20 000	98%	_____	102%
			100 000	96%	_____	104%
	1.18	0.10	100 000	96%	_____	104%
			20 000	98%	_____	102%
			1 000	98%	_____	102%
			20	98%	_____	102%
	1.19	0.07	20	98%	_____	102%
			1 000	98%	_____	102%
			20 000	98%	_____	102%
			50 000	96%	_____	104%
		100 000	96%	_____	104%	
		0.007	100 000	96%	_____	104%
			50 000	96%	_____	104%
			20 000	98%	_____	102%
			1 000	98%	_____	102%
			20	98%	_____	102%
1	High-Level, Low-Input AC Level Accuracy					
	1.1	300	20	98%	_____	102%
			1 000	98%	_____	102%
			20 000	98%	_____	102%
			100 000	96%	_____	104%
	1.2	150	100 000	96%	_____	104%
			20 000	98%	_____	102%
			1 000	98%	_____	102%
			20	98%	_____	102%
	1.3	100	20	98%	_____	102%
			1 000	98%	_____	102%
			20 000	98%	_____	102%
		100 000	96%	_____	104%	

Table 4-1. Performance Test Record (4 of 12)

Test No.	Test Description		Results			
			Minimum	Actual	Maximum	
1	AC LEVEL ACCURACY AND OUTPUT LEVEL ACCURACY AND FLATNESS PERFORMANCE TEST					
	High-Level, Low-Input AC Level Accuracy					
	Special Function	AC Calibrator				
		Level (Vrms)	Frequency (Hz)			
	1.4	70	100 000	96%	_____	104%
			20 000	98%	_____	102%
			1 000	98%	_____	102%
			20	98%	_____	102%
	1.5	45	20	98%	_____	102%
			1 000	98%	_____	102%
			20 000	98%	_____	102%
			100 000	96%	_____	104%
	1.6	30	100 000	96%	_____	104%
			20 000	98%	_____	102%
			1 000	98%	_____	102%
			20	98%	_____	102%
	1.7	15	20	98%	_____	102%
			1 000	98%	_____	102%
			20 000	98%	_____	102%
			100 000	96%	_____	104%
	1.8	10	100 000	96%	_____	104%
			20 000	98%	_____	102%
			1 000	98%	_____	102%
			20	98%	_____	102%
	1.9	7	20	98%	_____	102%
			1 000	98%	_____	102%
			20 000	98%	_____	102%
			100 000	96%	_____	104%
	1.10	4.5	100 000	96%	_____	104%
			20 000	98%	_____	102%
			1 000	98%	_____	102%
			20	98%	_____	102%
	1.11	3.0	20	98%	_____	102%
			1 000	98%	_____	102%
			20 000	98%	_____	102%
			100 000	96%	_____	104%

Table 4-1. Performance Test Record (5 of 12)

Test No.	Test Description			Results			
				Minimum	Actual	Maximum	
1	AC LEVEL ACCURACY AND OUTPUT LEVEL ACCURACY AND FLATNESS PERFORMANCE TEST						
	High-Level, Low-Input AC Level Accuracy						
			AC Calibrator				
		Special Function	Level (Vrms)	Frequency (Hz)			
		1.12	1.5	100 000	96%	_____	104%
				20 000	98%	_____	102%
				1 000	98%	_____	102%
				20	98%	_____	102%
		1.13	1.0	20	98%	_____	102%
				1 000	98%	_____	102%
				20 000	98%	_____	102%
				100 000	96%	_____	104%
		1.14	0.7	100 000	96%	_____	104%
				20 000	98%	_____	102%
				1 000	98%	_____	102%
				20	98%	_____	102%
		1.15	0.45	20	98%	_____	102%
				1 000	98%	_____	102%
				20 000	98%	_____	102%
				100 000	96%	_____	104%
		1.16	0.30	100 000	96%	_____	104%
				20 000	98%	_____	102%
				1 000	98%	_____	102%
				20	98%	_____	102%
		1.17	0.15	20	98%	_____	102%
				1 000	98%	_____	102%
				20 000	98%	_____	102%
				100 000	96%	_____	104%
	1.18	0.10	100 000	96%	_____	104%	
			20 000	98%	_____	102%	
			1 000	98%	_____	102%	
			20	98%	_____	102%	
	1.19	0.07	20	98%	_____	102%	
			1 000	98%	_____	102%	
			20 000	98%	_____	102%	
			100 000	96%	_____	104%	
		0.007	100 000	96%	_____	104%	
			20 000	98%	_____	102%	
			1 000	98%	_____	102%	
			20	98%	_____	102%	

Table 4-1. Performance Test Record (6 of 12)

Test No.	Test Description		Results			
			Minimum	Actual	Maximum	
1	AC LEVEL ACCURACY AND OUTPUT LEVEL ACCURACY AND FLATNESS PERFORMANCE TEST					
	Synthesizer Frequency (Hz)	Displayed Reading of Step b (%)				
	Low-Level, Low-Input AC Level Accuracy					
	20	_____	96%	_____	104%	
	1 000	_____	96%	_____	104%	
	20 000	_____	96%	_____	104%	
	100 000	_____	96%	_____	104%	
	Low-Level, High-Input AC Level Accuracy					
	100 000	_____	96%	_____	104%	
	20 000	_____	96%	_____	104%	
	1 000	_____	96%	_____	104%	
	20	_____	96%	_____	104%	
	Output Level Accuracy					
	Special Function	SOURCE				
		Amplitude (V)	Frequency (Hz)			
	1.9	6	20	98%	_____	102%
			1 000	98%	_____	102%
			20 000	98%	_____	102%
50 000			98%	_____	102%	
100 000			97%	_____	103%	
1.14	0.7	100 000	97%	_____	103%	
		50 000	98%	_____	102%	
		20 000	98%	_____	102%	
		1 000	98%	_____	102%	
		20	98%	_____	102%	
1.19	0.07	20	98%	_____	102%	
		1 000	98%	_____	102%	
		20 000	98%	_____	102%	
		50 000	98%	_____	102%	
		100 000	97%	_____	103%	
	0.007	100 000	97%	_____	103%	
		20 000	98%	_____	102%	
		1 000	98%	_____	102%	
		20	98%	_____	102%	
	0.0007	20	95%	_____	105%	
		1000	95%	_____	105%	
		20 000	95%	_____	105%	
		100 000	95%	_____	105%	

Table 4-1. Performance Test Record (7 of 12)

Test No.	Test Description	Results		
		Minimum	Actual	Maximum
1	AC LEVEL ACCURACY AND OUTPUT LEVEL ACCURACY AND FLATNESS PERFORMANCE TEST			
	Output Level Flatness			
	SOURCE			
	Amplitude (V)	Frequency (Hz)		
	6	20		0.7%
		20 000		0.7%
		50 000		2.5%
		100 000		2.5%
	0.7	20		0.7%
		20 000		0.7%
		50 000		2.5%
		100 000		2.5%
	0.07	20		0.7%
		20 000		0.7%
50 000			2.5%	
100 000			2.5%	
0.007	20		0.7%	
	20 000		0.7%	
	50 000		2.5%	
	100 000		2.5%	
2	DC LEVEL ACCURACY PERFORMANCE TEST			
	High-Input DC-Level Accuracy			
	DC Standard Voltage			
	300 Vdc	297 Vdc		303 Vdc
	30 Vdc	29.7 Vdc		30.3 Vdc
	3 Vdc	2.97 Vdc		3.03 Vdc
	0.6 Vdc	0.594 Vdc		0.606 Vdc
	0.06 Vdc	0.054 Vdc		0.066 Vdc
	Low-Input DC-Level Accuracy			
	DC Standard Voltage			
	0.06 Vdc	-0.066 Vdc		-0.054 Vdc
	0.6 Vdc	-0.606 Vdc		-0.594 Vdc
	3 Vdc	-3.03 Vdc		-2.97 Vdc
	30 Vdc	-30.3 Vdc		-29.7 Vdc
300 Vdc	-303 Vdc		-297 Vdc	
3	DISTORTION AND NOISE PERFORMANCE TEST			
	20 Hz / 6.0V / DISTN / 80 kHz			-80 dB
	1 kHz / 6.0V / DISTN / 80 kHz			-80 dB
	1 kHz / 5.0V / DISTN / 80 kHz			-80 dB
	1 kHz / 3.8V / DISTN / 80 kHz			-80 dB
	1 kHz / 0.6V / DISTN / 80 kHz			-80 dB
	1 kHz / 0.6V / SIG / NOISE / 80 kHz	+85 dB		-80 dB
	20 kHz / 6.0V / DISTN / 80 kHz			-70 dB
	50 kHz / 6.0V / DISTN / Off			-70 dB
	50 kHz / 0.6V / DISTN / Off			-70 dB
	50 kHz / 0.6V / SIG / NOISE / Off	+70 dB		-65 dB
	100 kHz / 6.0V / DIST / Off			-65 dB
	100 kHz / 5.0V / DIST / Off			-65 dB
	100 kHz / 3.8V / DIST / Off			-65 dB

Table 4-1. Performance Test Record (8 of 12)

Test No.	Test Description	Results		
		Minimum	Actual	Maximum
4	DISTORTION, SINAD AND SIGNAL-TO-NOISE ACCURACY PERFORMANCE TEST			
	Readings in step 9:			
	100 Hz / 10 dB / 25 Hz / DISTN	-11.4 dB	_____	-9.4 dB
	100 Hz / 10 dB / 25 Hz / SINAD	+9.4 dB	_____	+11.4 dB
	100 Hz / 80 dB / 25 Hz / SINAD	+79.0 dB	_____	+81.0 dB
	100 Hz / 80 dB / 25 Hz / DISTN	-81.0 dB	_____	-79.0 dB
	100 Hz / 80 dB / 50 Hz / SIG / NOISE	+79.0 dB	_____	+81.0 dB
	100 Hz / 10 dB / 50 Hz / SIG / NOISE	+9.4 dB	_____	+11.4 dB
	4.02 kHz / 10 dB / 2 kHz / DISTN	-11.4 dB	_____	-9.4 dB
	4.02 kHz / 20 dB / 2 kHz / DISTN	-21.0 dB	_____	-19.0 dB
	4.02 kHz / 30 dB / 2 kHz / DISTN	-31.0 dB	_____	-29.0 dB
	4.02 kHz / 40 dB / 2 kHz / DISTN	-41.0 dB	_____	-39.0 dB
	4.02 kHz / 50 dB / 2 kHz / DISTN	-51.0 dB	_____	-49.0 dB
	4.02 kHz / 60 dB / 2 kHz / DISTN	-61.0 dB	_____	-59.0 dB
	4.02 kHz / 70 dB / 2 kHz / DISTN	-71.0 dB	_____	-69.0 dB
	4.02 kHz / 80 dB / 2 kHz / DISTN	-81.0 dB	_____	-79.0 dB
	6.03 kHz / 80 dB / 2 kHz / DISTN	-81.0 dB	_____	-79.0 dB
	6.03 kHz / 10 dB / 2 kHz / DISTN	-11.4 dB	_____	-9.4 dB
	8.04 kHz / 10 dB / 2 kHz / DISTN	-11.4 dB	_____	-9.4 dB
	8.04 kHz / 80 dB / 2 kHz / DISTN	-81.0 dB	_____	-79.0 dB
	10.05 kHz / 80 dB / 2 kHz / DISTN	-81.0 dB	_____	-79.0 dB
	10.05 kHz / 10 dB / 2 kHz / DISTN	-11.4 dB	_____	-9.4 dB
	40.2 kHz / 10 dB / 20 kHz / DISTN	-11.4 dB	_____	-9.4 dB
	40.2 kHz / 10 dB / 20 kHz / SINAD	+9.4 dB	_____	+11.4 dB
	40.2 kHz / 10 dB / 20 kHz / SIG / NOISE	+9.4 dB	_____	+11.4 dB
	40.2 kHz / 80 dB / 20 kHz / SIG / NOISE	+79.0 dB	_____	+81.0 dB
	40.2 kHz / 80 dB / 20 kHz / SINAD	+79.0 dB	_____	+81.0 dB
	40.2 kHz / 80 dB / 20 kHz / DISTN	-81.0 dB	_____	-79.0 dB
	Readings in step 10.			
	201 kHz / 10 dB / 100 kHz / DISTN	+12.4 dB	_____	-8.4 dB
	201 kHz / 10 dB / 100 kHz / SINAD	+8.4 dB	_____	+12.4 dB
	201 kHz / 60 dB / 100 kHz / SINAD	+58.0 dB	_____	+62.0 dB
	201 kHz / 60 dB / 100 kHz / DISTN	-62.0 dB	_____	-58.0 dB
	301.5 kHz / 60 dB / 100 kHz / DISTN	-62.0 dB	_____	-58.0 dB
	301.5 kHz / 60 dB / 100 kHz / SINAD	+58.0 dB	_____	+62.0 dB
301.5 kHz / 10 dB / 100 kHz / SINAD	+8.4 dB	_____	+12.4 dB	
301.5 kHz / 10 dB / 100 kHz / DISTN	-12.4 dB	_____	-8.4 dB	

Table 4-1. Performance Test Record (9 of 12)

Test No.	Test Description		Results			
			Minimum	Actual	Maximum	
5	FREQUENCY ACCURACY AND SENSITIVITY PERFORMANCE TEST					
	MEASUREMENT Mode	Audio Input				
		Level (mV)	Frequency (Hz)			
	AC LEVEL	5	20	19.99	_____	20.01
	DISTN	50	20	19.99	_____	20.01
	DISTN	50	99 900	99 895	_____	99 905
	AC LEVEL	5	99 900	99 895	_____	99 905
	AC LEVEL	5	150 00	149 980	_____	150 020
			Source Frequency (Hz)			
			20	19.94	_____	20.06
			200	199.4	_____	200.6
			2 000	1 994	_____	2 006
			20 000	19 940	_____	20 060
			100 000	99 700	_____	100 300
6	AUDIO FILTERS PERFORMANCE TEST					
	High-Pass and Low Pass Filters					
	Initial SOURCE Frequency Setting (Hz)		Filter			
	400*		400 Hz HP	360 Hz	_____	440 Hz
	30 000		30 Hz LP	28 000 Hz	_____	32 000 Hz
	80 000		80 Hz LP	76 000 Hz	_____	84 000 Hz
	*Option 010 or 050					
	SOURCE Frequency (Hz)					
	CCITT Weighting Filter (Option 011 or 051)					
	50			-65.0 dB	_____	-61.0 dB
	100			-43.0 dB	_____	-39.0 dB
	200			-23.0 dB	_____	-19.0 dB
	300			-11.6 dB	_____	-9.6 dB
	500			-4.6 dB	_____	-2.6 dB
800			-0.2 dB	_____	+0.2 dB	
1 000			0.0 dB	_____	+2.0 dB	
2 000			-4.0 dB	_____	-2.0 dB	
3 000			-6.6 dB	_____	-4.6 dB	
3 500			-10.5 dB	_____	-6.5 dB	
5 000			-39.0 dB	_____	-33.0 dB	

Table 4-1. Performance Test Record (10 of 12)

Test No.	Test Description	Results			
		Minimum	Actual	Maximum	
6	AUDIO FILTERS PERFORMANCE TEST (Cont'd)				
	CCIR Weighting Filter (Option 012 or 052)				
	31.5	-31.9 dB	_____	-27.9 dB	
	63	-25.3 dB	_____	-22.5 dB	
	100	-20.8 dB	_____	-18.8 dB	
	200	-14.65 dB	_____	-12.95 dB	
	400	-8.5 dB	_____	-7.1 dB	
	800	-2.45 dB	_____	-1.35 dB	
	1 000	-0.5 dB	_____	+0.5 dB	
	2 000	+5.1 dB	_____	+6.1 dB	
	3 150	+8.5 dB	_____	+9.5 dB	
	4 000	+10.0 dB	_____	+11.0 dB	
	5 000	+11.2 dB	_____	+12.2 dB	
	6 300	+12.0 dB	_____	+12.4 dB	
	7 100	+11.8 dB	_____	+12.2 dB	
	8 000	+11.0 dB	_____	+11.8 dB	
	9 000	+9.5 dB	_____	+10.7 dB	
	10 000	+7.3 dB	_____	+8.9 dB	
	12 500	-1.2 dB	_____	+1.2 dB	
	14 000	-6.7 dB	_____	-3.9 dB	
	16 000	-13.35 dB	_____	-10.05 dB	
	20 000	-24.2 dB	_____	-20.2 dB	
	31 500		_____	-39.9 dB	
		C-Message Weighting Filter (Option 013 or 053)			
	60	-57.7 dB	_____	-53.7 dB	
	100	-44.5 dB	_____	-40.5 dB	
	200	-27.0 dB	_____	-23.0 dB	
	300	-17.5 dB	_____	-15.5 dB	
	400	-12.4 dB	_____	-10.4 dB	
	500	-8.5 dB	_____	-6.5 dB	
	600	-5.7 dB	_____	-3.7 dB	
	700	-3.7 dB	_____	-1.7 dB	
	800	-2.5 dB	_____	-0.5 dB	
	900	-1.6 dB	_____	+0.4 dB	
	1 000	-0.2 dB	_____	+0.2 dB	
	1 200	-1.2 dB	_____	+0.8 dB	
	1 300	-1.5 dB	_____	+0.5 dB	
	1 500	-2.0 dB	_____	0.0 dB	
	1 800	-2.3 dB	_____	-0.3 dB	
	2 000	-2.3 dB	_____	-0.3 dB	
	2 500	-2.4 dB	_____	-0.4 dB	
	2 800	-2.9 dB	_____	-0.9 dB	
	3 000	-3.5 dB	_____	-1.5 dB	
	3 300	-7.2 dB	_____	-3.2 dB	
	3 500	-9.6 dB	_____	-5.6 dB	
	4 000	-17.5 dB	_____	-11.5 dB	
	4 500	-24.5 dB	_____	-18.5 dB	
	5 000	-31.5 dB	_____	-25.5 dB	

Table 4-1. Performance Test Record (11 of 12)

Test No.	Test Description	Results			
		Minimum	Actual	Maximum	
6	AUDIO FILTERS PERFORMANCE TEST (Cont'd)				
	SOURCE Frequency (Hz) (Cont'd)				
	CCIR ARM Weighting Filter (Option 014 or 054)				
	31.5	-37.5 dB	_____	-33.5 dB	
	63	-30.9 dB	_____	-28.1 dB	
	100	-26.4 dB	_____	-24.4 dB	
	200	-20.25 dB	_____	-18.55 dB	
	400	-14.1 dB	_____	-12.7 dB	
	800	-8.05 dB	_____	-6.95 dB	
	1 000	-6.1 dB	_____	-5.1 dB	
	2 000	-0.5 dB	_____	+0.5 dB	
	3 150	+2.9 dB	_____	+3.9 dB	
	4 000	+4.4 dB	_____	+5.4 dB	
	5 000	+5.6 dB	_____	+6.6 dB	
	6 300	+6.4 dB	_____	+6.8 dB	
	7 100	+6.2 dB	_____	+6.6 dB	
	8 000	+5.4 dB	_____	+6.2 dB	
	9 000	+3.9 dB	_____	+5.1 dB	
	10 000	+1.7 dB	_____	+3.3 dB	
	12 500	-6.8 dB	_____	-4.4 dB	
	14 000	-12.3 dB	_____	-9.5 dB	
	16 000	-18.95 dB	_____	-15.65 dB	
	20 000	-29.8 dB	_____	-25.8 dB	
	31 500		_____	-45.5 dB	
		"A" Weighting Filter (Option 015 or 055)			
		20	-53.0 dB	_____	-48.0 dB
		25	-46.7 dB	_____	-42.7 dB
		31.5	-40.9 dB	_____	-37.9 dB
		40	-36.1 dB	_____	-33.1 dB
		50	-31.2 dB	_____	-29.2 dB
		63	-27.2 dB	_____	-25.2 dB
		80	-23.5 dB	_____	-21.5 dB
		100	-20.1 dB	_____	-18.1 dB
	125	-17.1 dB	_____	-15.1 dB	
	160	-14.4 dB	_____	-12.4 dB	
	200	-11.9 dB	_____	- 9.9 dB	
	250	-9.6 dB	_____	-7.6 dB	
	315	-7.6 dB	_____	-5.6 dB	
	400	-5.8 dB	_____	-3.8 dB	
	500	-4.2 dB	_____	-2.2 dB	
	630	-2.9 dB	_____	-0.9 dB	
	800	-1.8 dB	_____	+0.2 dB	
	1 000	-1.0 dB	_____	+1.0 dB	
	1 250	-0.4 dB	_____	+1.6 dB	
	1 600	+0.0 dB	_____	+2.0 dB	
	2 000	+0.2 dB	_____	+2.2 dB	
	2 500	+0.3 dB	_____	+2.3 dB	

Table 4-1. Performance Test Record (12 of 12)

Test No.	Test Description	Results			
		Minimum	Actual	Maximum	
6	AUDIO FILTERS PERFORMANCE TEST (Cont'd)				
	SOURCE Frequency (Hz) (Cont'd)				
	"A" Weighting Filter (Option 015 or 055) (Cont'd)				
	3 150	+0.2 dB	_____	+2.2 dB	
	4 000	+0.0 dB	_____	+2.0 dB	
	5 000	-1.5 dB	_____	+2.0 dB	
	6 300	-2.1 dB	_____	+1.4 dB	
	8 000	-4.1 dB	_____	+0.4 dB	
	10 000	-6.5 dB	_____	-0.5 dB	
	12 500	-10.3 dB	_____	-1.3 dB	
	16 000	-0.0 dB	_____	-3.3 dB	
	20 000	-0.0 dB	_____	-6.3 dB	
7	INPUT AND OUTPUT IMPEDANCE PERFORMANCE TEST				
	Output Impedance: 600Ω	49.90%	_____	50.40%	
	50Ω	49.00%	_____	51.00%	
	Input Impedance High Input	49.00%	_____	51.00%	
	Low Input	49.00%	_____	51.00%	
8	COMMON-MODE REJECTION RATIO PERFORMANCE TEST				
	Special Function	Oscillator Frequency (Hz)			
	1.12	20		_____	1
		1 000		_____	1
		20 000		_____	32
	1.1	20 000		_____	32
1 000			_____	5.6	
20			_____	5.6	

Section 5 ADJUSTMENTS

5-1. INTRODUCTION

This section contains adjustments and checks that assure peak performance of the Audio Analyzer. The instrument should be readjusted after repair or failure to pass a performance test. Allow a 30 minute warm-up prior to performing the adjustments. Removing the instrument top cover and the internal shield cover is the only disassembly required for all adjustments.

To determine which performance tests and adjustments to perform after a repair, refer to paragraph 5-5, *Post-Repair Tests, Adjustments, and Checks*.

5-2. SAFETY CONSIDERATIONS

This section contains information, cautions, and warnings which must be followed for your protection and to avoid damage to the equipment.

WARNING

Adjustments described in this section are performed with power supplied to the instrument and with protective covers removed. Maintenance should be performed only by service trained personnel who are aware of the hazard involved (for example, fire and electrical shock). Where maintenance can be performed without power applied, the power should be removed.

5-3. EQUIPMENT REQUIRED

Most adjustment procedures contain a list of required test equipment. The test equipment is also identified by callouts in the test setup diagrams, where included.

If substitutions must be made for the specified test equipment, refer to Table 1-3 in Section 1 of this manual for the minimum specifications. It is important that the test equipment meet the critical specifications listed in the table if the Audio Analyzer is to meet its performance requirements.

5-4. FACTORY-SELECTED COMPONENTS

Factory-selected components are identified on the schematics and parts list by an asterisk (*) which follows the reference designator. The normal value or range of the components is shown. Manual Update addition and replacement pages provide updated information pertaining to the selected components. Table 5-1 lists the reference designator, the criteria used for selecting a particular value, the normal value range and the service sheet where the component part is shown.

Table 5-1. Factory Selected Components

Reference Designator	Service Sheet	Range of Values	Basis of Selection
A2C4	1	43 to 56 pF	See <i>Input Flatness Adjustment</i>
A2C9 and A2C102	1	6.2 to 7.5 pF	See <i>Input Flatness Adjustment</i>
A4R143 and A4R144	6	147 k Ω to infinity	See <i>Voltmeter Adjustment</i>
A6C26	11	0 to 25 pF	See <i>Oscillator and Output Attenuator Attenuator Adjustment</i>
A7R8	13	7.32 to 7.68 k Ω	If the voltage at the Y AXIS output is >10.3 Vdc at full scale, increase the value of the A7R8; if the voltage is <9.7 Vdc, reduce the value.
A7R10	13	7.32 to 7.68 k Ω	If the voltage at the X AXIS output is >10.3 Vdc at full scale, increase the value of A7R10; if the voltage is <9.7 Vdc, reduce the value.

5-5. POST-REPAIR TESTS, ADJUSTMENTS, AND CHECKS

Table 5-2 lists the performance tests, adjustments and checks needed to calibrate or verify calibration of a repaired assembly. The tests, adjustments, and checks are classified by assembly repaired.

The table is also useful as a cross reference between performance tests and assemblies when the failure is a specification that is slightly out of limits.

After all repairs, perform the *Basic Functional Checks* (paragraph 3-5) and the *Internal Reference Frequency Adjustment* (Adjustment 1). The Basic Functional Checks utilize automatic tuning and measurements which exercise nearly every circuit in the instrument (except the Remote Interface Assembly).

5-6. RELATED ADJUSTMENTS

The procedures in this section can be done in any order, but it is advisable to check the time base reference first.

Table 5-2. Post-Repair Tests, Adjustments, and Checks

Assembly Repaired	Test, Adjustment, or Check	Ref*
A1 Keyboard and Display Assembly	Power-Up Checks Service Special Functions (Use 60.0 SPCL, Key Scan, and exercise all keys.)	P 8-27 8-23
A2 Input Amplifier Assembly	AC Level Accuracy and Output Level Accuracy and Flatness Performance Test (Check ac level accuracy only.) DC Level Accuracy Performance Test Distortion and Noise Performance Test Audio Filters Performance Test Common-Mode Rejection Ration Performance Test Input Flatness Adjustment Common-Mode Rejection Adjustment Input DC Offset Adjustment 400 Hz High-Pass and Weighting Bandpass Filters Adjustment	PT1 PT2 PT3 PT6 PT8 ADJ2 ADJ3 ADJ4 ADJ5
A3 Notch Filter Assembly	Distortion and Noise Performance Test Distortion, SINAD, and Signal-to-Noise Accuracy Performance Test Notch Filter Tune and Balance Adjustment	PT3 PT4 ADJ6
A4 Output Amplifier/Voltmeter Assembly	AC Level Accuracy and Output Level Accuracy and Flatness Performance Test (Check ac level accuracy only.) DC Level Accuracy Performance Test Distortion and NOise Performance Test Distortion, SINAD, and Signal-to-Noise Accuracy Performance Test Voltmeter Adjustment SINAD Meter Adjustment	PT1 PT2 PT3 PT4 ADJ7 ADJ8
A5 Oscillator Assembly	Ac Level Accuracy and Output Level Accuracy and Flatness Performance Test Distortion and Noise Performance Test Frequency Accuracy and Sensitivity Performance Test Oscillator and Output Attenuator Adjustment	PT1 PT3 PT5 ADJ9
A6 Output Attenuator Assembly	AC Level Accuracy and Output Level Accuracy and Flatness Performance Test Distortion and Noise Performance Test Input and Output Impedance Test	PT1 PT3 PT7
A7 Latch Assembly	Basic Functional Checks Frequency Accuracy and Sensitivity Performance Test Power-Up Checks	P 3-5 PT5 P 8-27
A8 Controller/Counter Assembly	Basic Functional Checks Frequency Accuracy and Sensitivity Performance Test Internal Reference Frequency Adjustment Power-Up Checks	P 3-5 PT5 ADJ1 P 8-27
A9 Remote Interface Assembly A10 Remote Interface Connector Assembly	HP-IB Functional Checks Power-Up Checks	P 3-6 P 8-27
A11 Series Regulator Socket Assembly A12 Connector/Filter Assembly A13 Power Supply and Motherboard Assembly A14 Line Power Module	Basic functional Checks Power-Up Checks	P 3-5 P 8-27
* P = Paragraph PT = Performance Test ADJ = Adjustment		

Adjustment 1

INTERNAL REFERENCE FREQUENCY ADJUSTMENT

Reference

Service Sheet 15.

Description

An oscilloscope, triggered by an external reference is used to monitor the internal reference frequency while it is adjusted.

Equipment

Frequency Standard House Standard
Oscilloscope HP 1740A

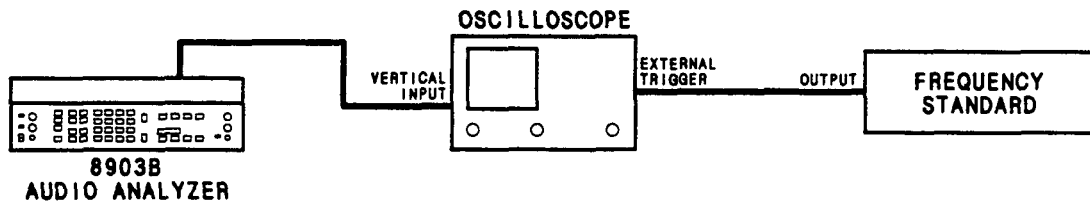

Figure 5-1. Internal Reference Frequency Adjustment Test Setup

Procedure

1. Allow the equipment to warm up for 15 minutes.
2. Connect the equipment as shown in Figure 5-1. For instruments with *Serial Prefix 2922A and below*, connect the oscilloscope to A8TP15. For instruments with *Serial Prefix 2948A and above*, connect the oscilloscope to A8TP2. (The figure shows the setup for house-standard frequencies of 2 MHz or lower. If the frequency of the frequency standard is 5 or 10 MHz, reverse the vertical input and external trigger connections on the oscilloscope.)
3. Set the oscilloscope's vertical sensitivity to view the Audio Analyzer's time base reference (or the frequency standard output). Set the horizontal scale for 0.1 μ s per division. Set the oscilloscope to trigger externally.
4. Adjust A8C27 (*Serial Prefix 2922A and below*), A8C41 (*Serial Prefix 2948A and above*) for a waveform movement of 10 divisions per second or less. A totally non-metallic adjustment tool is recommended.

NOTE

A movement of the waveform to the right (or left if the oscilloscope connections are reversed) at a rate of one division per second means that the Audio Analyzer's time base frequency is low by 0.1 ppm.

Adjustment 2

INPUT FLATNESS ADJUSTMENT

Reference

Service Sheet 1.

Description

An ac calibrator is connected to the high input of the Audio Analyzer. The Audio Analyzer is set to measure ac level. The frequency of the calibrator is varied between 1, 40, and 100 kHz and the flatness adjusted for a constant level at all three frequencies. The procedure is then repeated with the ac calibrator connected to the low input.

WARNING

Voltages up to 60 Vrms will be applied to the Audio Analyzer's input connectors and will be present on the assembly being adjusted. Do not extend the assembly or probe its circuitry when high voltage is applied to the input.

Equipment

AC Calibrator HP 745A or Datron 4200 or Fluke 5200A

Procedure

High-Input Flatness

1. Set the ac calibrator to 1 kHz at 4.5 Vrms.
2. On the Audio Analyzer, key in 41.0 SPCL to initialize the instrument. Set the INPUT switch to ground. Set LP FILTER off. Key in 1.10 SPCL to set the input to the 4.76V range.
3. Connect the ac calibrator output directly to the HIGH INPUT of the Audio Analyzer.
4. The right display of the Audio Analyzer should read between 4.4 and 4.6V. Press RATIO.
5. Set the ac calibrator frequency to 40 kHz. Adjust A2C3 (HIGH 12 DB) for a reading on the right display between 99.70 and 100.3%.
6. Set the ac calibrator frequency to 100 kHz. Adjust A2C3 for a reading between 99.50 and 100.5%. Repeat steps 5 and 6 as often as needed until the flatness at 40 kHz and 100 kHz is within the limits given. (See the following note.)

NOTE

If the flatness cannot be adjusted so that the 40 kHz and 100 kHz readings are both within the given limits, change A2C4 as follows: If the 100 kHz reading is higher than at 40 kHz, decrease A2C4 by approximately 10%. If the 40 kHz reading is higher than that at 100 kHz, increase A2C4 by approximately 10%.

7. On the Audio Analyzer, press RATIO to turn it off. Key in 1.7 SPCL to set the input to the 18.9V range.
8. Set the ac calibrator frequency to 1 kHz and level to 15 Vrms.
9. The right display of the Audio Analyzer should read between 14.7 and 15.3V. Press RATIO.
10. Set the ac calibrator frequency to 40 kHz. Adjust A2C10 (HIGH 24 DB) for a reading on the right display between 99.70 and 100.3%.
11. Set the ac calibrator frequency to 100 kHz. Adjust A2C10 for a reading between 99.50 and 100.5%. Repeat steps 10 and 11 as often as needed until the flatness at 40 kHz and 100 kHz is within the limits given.

NOTE

If the flatness cannot be adjusted so that the 40 kHz and 100 kHz readings are both within the given limits, change A2C9 as follows: If the 100 kHz reading is higher than at 40 kHz, decrease A2C9 by approximately 10%. If the 40 kHz reading is higher than that at 100 kHz, increase A2C4 by approximately 10%.

12. On the Audio Analyzer, press RATIO to turn it off. Key in 1.4 SPCL to set the input to the 75.4V range.
13. Set the ac calibrator frequency to 1 kHz and level to 60 Vrms.
14. The right display of the Audio Analyzer should read between 58.8 and 61.2V. Press RATIO.
15. Set the ac calibrator frequency to 40 kHz. Adjust A2C109 (HIGH 40 DB) for a reading on the right display between 99.70 and 100.3%.
16. Set the ac calibrator frequency to 100 kHz. Adjust A2C109 for a reading between 99.50 and 100.5%. Repeat steps 15 and 16 as often as needed until the flatness at 40 kHz and 100 kHz is within the limits given.

Low-Input Flatness

17. Set the ac calibrator to 1 kHz at 4.5 Vrms.
18. On the Audio Analyzer, key in 41.0 SPCL to initialize the instrument. Set the INPUT switch to FLOAT. Set LP FILTER off. Key in 1.10 SPCL to set the input to the 4.76V range.
19. Connect the ac calibrator output to the LOW INPUT of the Audio Analyzer. Short the HIGH INPUT to ground.
20. The right display of the Audio Analyzer should read between 4.4 and 4.6V. Press RATIO.
21. Set the ac calibrator frequency to 40 kHz. Adjust A2C90 (LOW 12 DB) for a reading on the right display between 99.70 and 100.3%.
22. Set the ac calibrator frequency to 100 kHz. Adjust A2C90 for a reading between 99.50 and 100.5%. Repeat steps 21 and 22 as often as needed until the flatness at 40 kHz and 100 kHz is within the limits given. (See the following note.)

NOTE

If the flatness cannot be adjusted so that the 40 kHz and 100 kHz readings are both within the given limits, change A2C89 as follows: If the 100 kHz reading is higher than at 40 kHz, decrease A2C4 by approximately 10%. If the 40 kHz reading is higher than that at 100 kHz, increase A2C89 by approximately 10%.

23. On the Audio Analyzer, press **RATIO** to turn it off. Key in 1.7 SPCL to set the input to the 18.9V range.
24. Set the ac calibrator frequency to 1 kHz and level to 15 Vrms.
25. The right display of the Audio Analyzer should read between 14.7 and 15.3V. Press **RATIO**.
26. Set the ac calibrator frequency to 40 kHz. Adjust A2C92 (LOW 24 DB) for a reading on the right display between 99.70 and 100.3%.
27. Set the ac calibrator frequency to 100 kHz. Adjust A2C92 for a reading between 99.50 and 100.5%. Repeat steps 26 and 27 as often as needed until the flatness at 40 kHz and 100 kHz is within the limits given.

NOTE

If the flatness cannot be adjusted so that the 40 kHz and 100 kHz readings are both within the given limits, change A2C102 as follows: If the 100 kHz reading is higher than at 40 kHz, decrease A2C102 by approximately 10%. If the 40 kHz reading is higher than that at 100 kHz, increase A2C102 by approximately 10%.

28. On the Audio Analyzer, press **RATIO** to turn it off. Key in 1.4 SPCL to set the input to the 75.4V range.
29. Set the ac calibrator frequency to 1 kHz and level to 60 Vrms.
30. The right display of the Audio Analyzer should read between 58.8 and 61.2V. Press **RATIO**.
31. Set the ac calibrator frequency to 40 kHz. Adjust A2C110 (LOW 40 DB) for a reading on the right display between 99.70 and 100.3%.
32. Set the ac calibrator frequency to 100 kHz. Adjust A2C110 for a reading between 99.50 and 100.5%. Repeat steps 31 and 32 as often as needed until the flatness at 40 kHz and 100 kHz is within the limits given.
33. Perform the ac level accuracy portion of the *AC Level Accuracy and Output Level Accuracy and Flatness Performance Test* (Performance Test 1).

Adjustment 3

COMMON-MODE REJECTION ADJUSTMENT

Reference

Service Sheet 1.

Description

The output from the Audio Analyzer's source, set to 1 V_{rms} at 1 kHz, is connected to both the high and low inputs to the Audio Analyzer. The low input is set to float. The ac level of the common-mode rejection is then adjusted for minimum response.

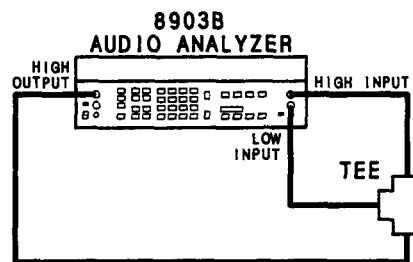

Figure 5-2. Common-Mode Rejection Adjustment Test Setup

Procedure

1. On the Audio Analyzer, key in 41.0 SPCL to initialize the instrument. Set the OUTPUT switch to ground. Set the INPUT switch to FLOAT. Key in 47.0 SPCL to set the Source impedance to 600 Ω . Set AMPTD to 1V.
2. Connect the HIGH OUTPUT to the HIGH INPUT through the tee as shown in Figure 5-2.
3. Adjust A2R43 (CM) for the minimum level on the right display, but less than 0.2 mV.
4. Perform the *Common-Mode Rejection Ratio Performance Test* (Performance Test 8).

Adjustment 4

INPUT DC OFFSET ADJUSTMENT

Reference

Service Sheet 1.

Description

With the Audio Analyzer set to measure dc level and the input grounded, the dc offset is adjusted for a display of 0V.

Equipment

Feedthrough Termination, 600Ω HP 11095A

Procedure

1. Key in 41.0 SPCL to initialize the instrument. Set the INPUT switch to ground. Set MEASUREMENT to DC LEVEL.
2. Connect the 600Ω feedthrough (or a short circuit, or a 50Ω load) to the HIGH INPUT.
3. Adjust A2R44 (OFFSET) for a steady reading of -0.00V on the right display.

Adjustment 5

400 HZ HIGH-PASS AND WEIGHTING BANDPASS FILTERS ADJUSTMENT

Reference

Service Sheet 2, 2A, and 2B.

Description

The source output of the Audio Analyzer is connected to the input. The source is set to a specified frequency, and a level reference is set. The filter to be adjusted is then inserted and its gain is adjusted for a level equal to the reference.

Procedure

NOTE

In the following procedures, the leftmost filter circuit board is designated A2A1 and the rightmost board A2A2. The board location corresponds to option series 010 and 050 respectively.

1. Key in 41.0 SPCL to initialize the instrument. Set the INPUT and OUTPUT switches both to ground. Connect the HIGH OUTPUT to the HIGH INPUT. Set AMPTD to 1V.
2. Perform the following steps for the filters installed.

400 Hz High-Pass Filter (Option 010 or 050)

- a. Set RATIO off. Set FREQ to 2 kHz. Set RATIO on.
- b. Press HIGH PASS 400 Hz. Adjust A2A1R6 or A2A2R6 (400 HZ) for a reading between 99.60 and 99.80% on the right display.
- c. Set FREQ to 1 kHz. The right display should read between 99.00 and 101.0%.

CCITT Weighting Filter (Option 011 or 051)

- a. Set HIGH PASS 400 Hz off (if on). Set FREQ to 800 Hz. Set RATIO off, then back on.
- b. Press CCITT WEIGHTING. Adjust A2A1R4 or A2A2R4 (CCITT) for a steady reading of 100.0% on the right display.

CCIR Weighting Filter (Option 012 or 052)

- a. Set HIGH PASS 400 Hz off (if on). Set FREQ to 6800 Hz. Set RATIO off, then back on.
- b. Press CCIR WEIGHTING. Adjust A2A1R7 or A2A2R7 (CCIR) for a steady reading of 407.4% (12.20 dB) on the right display.

C-Message Weighting Filter (Option 013 or 053)

- a. Set HIGH PASS 400 Hz off (if on). Set FREQ to 1 kHz. Set RATIO off, then back on.
- b. Press C-MESSAGE WEIGHTING. Adjust A2A1R6 or A2A2R6 (CMSG) for a steady reading of 100.0% on the right display.

CCIR/ARM Weighting Filter (Option 014 or 054)

- a. Set HIGH PASS 400 Hz off (if on). Set FREQ to 6800 Hz. Set RATIO off, then back on.
- b. Press CCIR/ARM WEIGHTING. Adjust A2A1R7 or A2A2R7 (CCIR) for a steady reading of 213.8% (6.6 dB) on the right display.

“A” Weighting Filter (Option 015 or 055)

- a. Set HIGH PASS 400 Hz off (if on). Set FREQ to 1 kHz. Set RATIO off, then back on.
- b. Press “A” WEIGHTING. Adjust A2A1R3 or A2A2R3 (A-WTD) for a steady reading of 100.0% on the right display.
3. Perform the *Audio Filters Performance Test* (Performance Test 6).

Adjustment 6

NOTCH FILTER TUNE AND BALANCE ADJUSTMENT

Reference

Service Sheet 4.

Description

The Audio Analyzer is set to measure the distortion from its source. The output from the notch filter is observed on an oscilloscope while the tuning and balance are adjusted for a minimum. The measured distortion is also monitored on the amplitude display.

Equipment

Oscilloscope HP 1740A

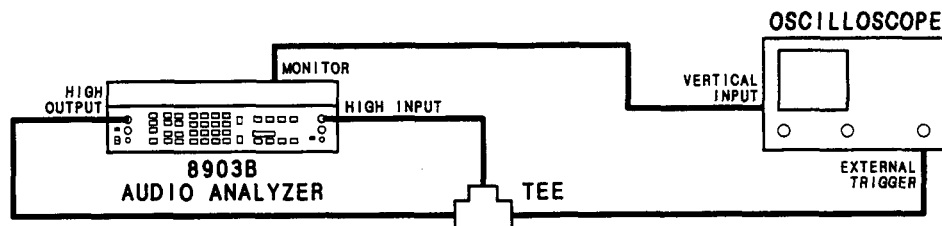

Figure 5-3. Notch Filter Tune and Balance Adjustment Test Setup

Procedure

1. On the Audio Analyzer, key in 41.0 SPCL to initialize the instrument. Set the INPUT and OUTPUT switches both to ground. Set AMPTD to 3V. Set MEASUREMENT to DISTN. Set LOG/LIN to LOG.
2. Connect the equipment as shown in Figure 5-3.
3. Set the oscilloscope to view the ac signal at the rear-panel MONITOR output. Set the oscilloscope's trigger to external.
4. Adjust A3R62 (TUNE OFST) and A3R63 (BAL OFST) for minimum signal and noise on the oscilloscope display.
5. Observe the right display of the Audio Analyzer. It should read -90 dB or less. Readjust the two adjustments to minimize the reading on the display which must be -90 dB or less.

NOTE

If the reading of step 5 cannot be brought within limit, it may be that the source has excessive distortion.

Adjustment 7

VOLTMETER ADJUSTMENT

Reference

Service Sheets 6 and 7.

Description

The Audio Analyzer is set to measure the ac level from its source. The internal ac-to-dc converter (as yet uncalibrated) produces a dc voltage that is read by the internal dc voltmeter and monitored by an external dc voltmeter. The sensitivity of the internal dc voltmeter is adjusted so that the amplitude display of the Audio Analyzer agrees with the level measured by the external dc voltmeter.

The ac at the source's output jack is then monitored by an external ac voltmeter. The ac-to-dc converter is adjusted so that the amplitude display of the Audio Analyzer agrees with the level measured by the external ac voltmeter at two different levels. Since there are two ac-to-dc converters (one true-rms responding and one average responding), two separate adjustments are made.

Equipment

Digital Voltmeter HP 3455A

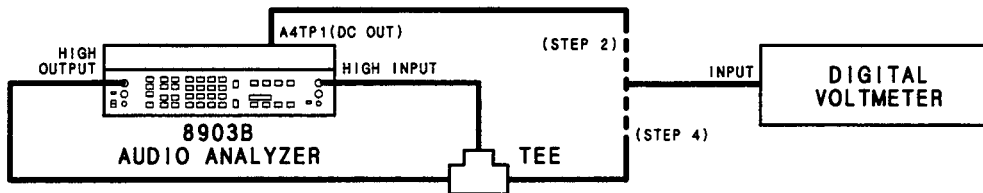

Figure 5-4. Voltmeter Adjustment Test Setup

Procedure

1. On the Audio Analyzer, key in 41.0 SPCL to initialize the instrument. Key in 1.11 SPCL to set the input range to 3.00V. Key in 3.1 SPCL to set the post-notch amplifier gain to 0 dB. Set AMPTD to 3V. Key in 49.3 SPCL to read the output rms detector voltage directly. Set the INPUT and OUTPUT switches both to ground.
2. Connect the equipment as shown in Figure 5-4. Connect the voltmeter to A4TP1 (DC OUT).
3. Set the voltmeter to read dc volts. Adjust A4R125 (DC CAL) for a reading on the right display of the Audio Analyzer that is the same as the reading on the voltmeter (within ± 0.5 mV). (See Service Sheet 7.)
4. Connect the voltmeter to the HIGH INPUT of the Audio Analyzer as shown in Figure 5-4. Set the voltmeter to read ac volts. On the Audio Analyzer, set the MEASUREMENT mode to AC LEVEL.
5. Adjust A4R91 (RMS SCALE) for a reading on the right display of the Audio Analyzer that is the same as the reading on the ac voltmeter (within ± 1 mV). (See Service Sheet 6.)

6. On the Audio Analyzer, set AMPTD to 150 mV. Adjust A4R85 (RMS OFFSET) for a reading on the right display of the Audio Analyzer that is the same as the ac reading on the ac voltmeter (within 0.5 mV). (See Service Sheet 6.) If A4R85 does not have sufficient range, add or alter A4R143 or A4R144 as follows:
 - a. Unsolder A4R143 or A4R144 if present.
 - b. With a dc voltmeter, measure the voltage at the junction of A4R72 and A4C46.
 - c. If the voltage (ignoring polarity) is greater than 2 mV, compute $R=1500/V$, where V is the voltage measured (in volts).
 - d. Select a resistor which has a standard value resistance nearest R. If the measured voltage was negative, solder the resistor in the location for A4R143, if positive, for A4R144.
 - e. After a five-minute warm up, measure the voltage again which should be between -2 and +2 mVdc.
 - f. Repeat the adjustment of A4R85.
7. On the Audio Analyzer, set AMPTD to 3V. Repeat steps 5 through 7 until the right display of the Audio Analyzer and the ac voltmeter readings are the same within the limits stated for both 3V and 150 mV.
8. On the Audio Analyzer, key in 5.2 SPCL to select the averaging detector. Set AMPTD to 3V.
9. Adjust A4R93 (AVG SCALE) for a reading on the right display of the Audio Analyzer that is the same as the reading on the ac voltmeter (within ± 1 mV). (See Service Sheet 6.)
10. Set AMPTD to 150 mV. Adjust A4R149 (AVG OFFSET) for a reading on the right display of the Audio Analyzer that is the same as the reading on the ac voltmeter (within ± 0.5 mV). (See Service Sheet 6.)
11. Set AMPTD to 3V. Repeat steps 9 through 11 until the right display of the Audio Analyzer and the ac voltmeter are the same (within the limits stated for both 3V and 150 mV).
12. Key in 5.7 SPCL to select the quasi-peak detector.
13. Adjust A4R207 (QUASI-PEAK) for a reading on the right display of the Audio Analyzer that is the same as the reading on the ac voltmeter (within ± 1 mV). (See Service Sheet 6)

Adjustment 8

SINAD METER ADJUSTMENT

Reference

Service Sheet 6.

Description

The SINAD meter is mechanically zeroed with the measurement mode not set to SINAD. Next, a signal from the internal source is fed into the input, the measurement mode is set to SINAD, and the notch filter allowed to tune to the signal. The notch filter is then held and the frequency of the source is offset to mistune the notch filter. The mistuning produces a SINAD reading within the range of the SINAD meter. The meter is then adjusted to agree with the displayed SINAD.

Procedure

1. On the Audio Analyzer, key in 41.0 SPCL to initialize the instrument. Set the INPUT and OUTPUT switches both to ground. Key in 16.1 SPCL to set the SINAD resolution to 0.01 dB. Place the instrument in its normal operating position.
2. Connect the HIGH OUTPUT to the HIGH INPUT.
3. Adjust the mechanical zero adjustment screw on the panel meter cw for a zero meter reading, then turn the screw slightly ccw to free the mechanism from the adjusting peg.
4. Set AMPTD to 3V and MEASUREMENT to SINAD. Key in 7.1 SPCL to enable the 24 dB SINAD meter range. Key in 6.1 SPCL to hold the notch filter.
5. Set FREQ to 890 Hz. Fine adjust the source frequency to obtain a reading on the right display between 12 and 18 dB.
6. Adjust A4R142 (METER CAL) so that the panel meter reads the same as the right display.

Adjustment 9

OSCILLATOR AND OUTPUT ATTENUATOR ADJUSTMENT

Reference

Service Sheets 9, 10 and 11.

Description

With the oscillator turned off, the dc offset of the output circuits is adjusted for 0V. The oscillator is then turned on and adjusted at 1 kHz for 6 Vrms output into an open circuit. Finally, the oscillator is set to 50 mV at 100 kHz, and the high-frequency balance of the output amplifier is adjusted so that the voltage between the source's low output and ground is minimum when measured by the internal ac voltmeter.

Equipment

Digital Voltmeter HP 3455A

Procedure

1. On the Audio Analyzer, key in 41.0 SPCL to initialize the instrument. Set the INPUT and OUTPUT switches both to ground.
2. Connect the dc voltmeter to the OUTPUT connector on the Audio Analyzer.
3. Adjust A6R32 (R32) for 0 ± 0.1 mVdc as read on the voltmeter. (See Service Sheet 10.)
4. Set the voltmeter to read ac volts.
5. On the Audio Analyzer, set AMPTD to 6V. Adjust A5R102 (OUTPUT LEVEL) for an output level of 6 Vrms displayed on the voltmeter.
6. On the Audio Analyzer, set FREQ to 100 kHz, AMPTD to 50 mV, and LP FILTER off. Set the OUTPUT switch to FLOAT. Disconnect the ac voltmeter from the HIGH OUTPUT connector. Connect the LOW OUTPUT to the HIGH INPUT.
7. Adjust A6C25 (not labeled) so that the plates go from fully meshed to fully open. The right display on the Audio Analyzer should go through a minimum. Adjust A6C25 for the minimum display. If the adjustment does not go through a minimum, change A6C26 to 20 pF if the lowest reading occurs with the plates of A6C25 fully meshed, or remove A6C26 if the lowest reading occurs with the plates fully open. Then readjust A6C25. (See Service Sheet 11.)

REGIONAL SALES AND SERVICE OFFICES

NORTH/CENTRAL AFRICA

Hewlett-Packard S.A.
7, rue du Bois-du-Lan
CH-1217 MEYRIN 1, Switzerland
Tel: (022) 83 12 12
Telex: 27835 hmea
Cable: HEWPACKSA Geneve

ASIA

Hewlett-Packard Asia Ltd.
47/F, 26 Harbour Rd.,
Wanchai, **HONG KONG**
G.P.O. Box 863, Hong Kong
Tel: 5-8330833
Telex: 76793 HPA HX
Cable: HPASIAL TD

MEDITERRANEAN AND MIDDLE EAST

Hewlett-Packard S.A.
Mediterranean and Middle East
Operations
Atrina Centre
32 Kifissias Ave.
Paradissos-Amarousion, **ATHENS**
Greece
Tel: 682 88 11
Telex: 21-6588 HPAT GR
Cable: HEWPACKSA Athens

EASTERN EUROPE

Hewlett-Packard Ges.m.b.h.
Lieblgasse 1
P.O. Box 72
A-1222 **VIENNA**, Austria
Tel: (222) 2500-0
Telex: 1 3 4425 HEPA A

NORTHERN EUROPE

Hewlett-Packard S.A.
Uilenstede 475
P.O. Box 999
NL-1183 AG **AMSTELVEEN**
The Netherlands
Tel: 20 437771
Telex: 18 919 hpner nl

SOUTH EAST EUROPE

Hewlett-Packard S.A.
World Trade Center
110 Avenue Louis Casai
1215 Cointrin, **GENEVA**, Switzerland
Tel: (022) 98 96 51
Telex: 27225 hpser

OTHER INTERNATIONAL AREAS

Hewlett-Packard Co.
Intercontinental Headquarters
3495 Deer Creek Road
PALO ALTO, CA 94304
Tel: (415) 857-1501
Telex: 034-8300
Cable: HEWPACK

EASTERN USA

Hewlett-Packard Co.
4 Choke Cherry Road
ROCKVILLE, MD 20850
Tel: (301) 258-2000

MIDWESTERN USA

Hewlett-Packard Co.
5201 Tollview Drive
ROLLING MEADOWS, IL 60008
Tel: (312) 255-9800

SOUTHERN USA

Hewlett-Packard Co.
2000 South Park Place
P.O. Box 105005
ATLANTA, GA 30348
Tel: (404) 955-1500

WESTERN USA

Hewlett-Packard Co.
3939 Lankershim Blvd.
P.O. Box 3919
LOS ANGELES, CA 91604
Tel: (213) 506-3700

CANADA

Hewlett-Packard (Canada) Ltd.
6877 Goreway Drive
MISSISSAUGA, Ontario L4V 1M8
Tel: (416) 678-9430
Telex: 610-492-4246