

Errata

Title & Document Type: 8745A S-Parameter Test Set Operating and Service Manual

Manual Part Number: 08745-90009

Revision Date: February 1982

About this Manual

We've added this manual to the Agilent website in an effort to help you support your product. This manual provides the best information we could find. It may be incomplete or contain dated information, and the scan quality may not be ideal. If we find a better copy in the future, we will add it to the Agilent website.

HP References in this Manual

This manual may contain references to HP or Hewlett-Packard. Please note that Hewlett-Packard's former test and measurement, life sciences, and chemical analysis businesses are now part of Agilent Technologies. The HP XXXX referred to in this document is now the Agilent XXXX. For example, model number HP8648A is now model number Agilent 8648A. We have made no changes to this manual copy.

Support for Your Product

Agilent no longer sells or supports this product. You will find any other available product information on the Agilent Test & Measurement website:

www.agilent.com

Search for the model number of this product, and the resulting product page will guide you to any available information. Our service centers may be able to perform calibration if no repair parts are needed, but no other support from Agilent is available.



Agilent Technologies

OPERATING AND SERVICE MANUAL

8745A S-PARAMETER TEST SET

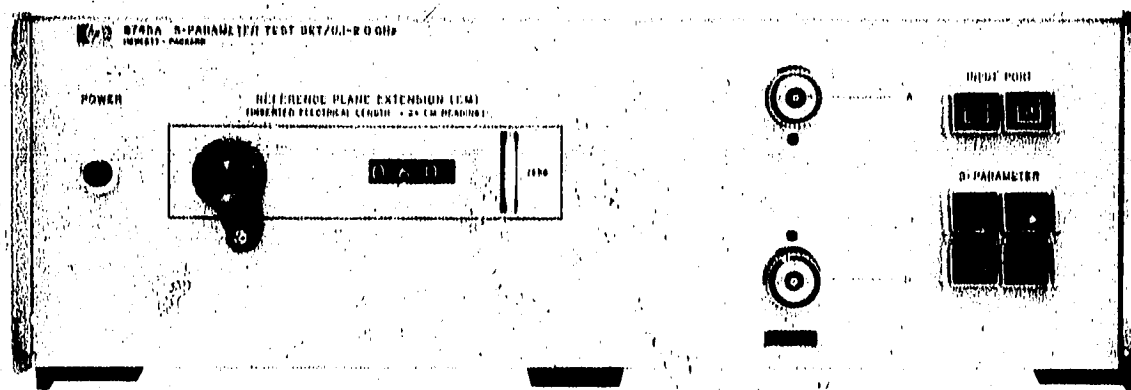

 **HEWLETT
PACKARD**

CERTIFICATION

Hewlett-Packard Company certifies that this product met its published specifications at the time of shipment from the factory. Hewlett-Packard further certifies that its calibration measurements are traceable to the United States National Bureau of Standards, to the extent allowed by the Bureau's calibration facility, and to the calibration facilities of other International Standards Organization members.

WARRANTY

This Hewlett-Packard instrument product is warranted against defects in material and workmanship for a period of one year from date of shipment. During the warranty period, Hewlett-Packard Company will, at its option, either repair or replace products which prove to be defective.

For warranty service or repair, this product must be returned to a service facility designated by HP. Buyer shall prepay shipping charges to HP and HP shall pay shipping charges to return the product to Buyer. However, Buyer shall pay all shipping charges, duties, and taxes for products returned to HP from another country.

HP warrants that its software and firmware designated by HP for use with an instrument will execute its programming instructions when properly installed on that instrument. HP does not warrant that the operation of the instrument, or software, or firmware will be uninterrupted or error free.

LIMITATION OF WARRANTY

The foregoing warranty shall not apply to defects resulting from improper or inadequate maintenance by Buyer, Buyer-supplied software or interfacing, unauthorized modification or misuse, operation outside of the environmental specifications for the product, or improper site preparation or maintenance.

NO OTHER WARRANTY IS EXPRESSED OR IMPLIED. HP SPECIFICALLY DISCLAIMS THE IMPLIED WARRANTIES OF MERCHANTABILITY AND FITNESS FOR A PARTICULAR PURPOSE.

EXCLUSIVE REMEDIES

THE REMEDIES PROVIDED HEREIN ARE BUYER'S SOLE AND EXCLUSIVE REMEDIES. HP SHALL NOT BE LIABLE FOR ANY DIRECT, INDIRECT, SPECIAL, INCIDENTAL, OR CONSEQUENTIAL DAMAGES, WHETHER BASED ON CONTRACT, TORT, OR ANY OTHER LEGAL THEORY.

ASSISTANCE

Product maintenance agreements and other customer assistance agreements are available for Hewlett-Packard products.

For any assistance, contact your nearest Hewlett-Packard Sales and Service Office. Addresses are provided at the back of this manual.

8745A

S-PARAMETER TEST SET

SERIALS PREFIXED: 978-

This manual applies directly to HP Model 8745A S-Parameter Test Set Units having serial numbers prefixed 978-

SERIALS PREFIXED: 823-, 906-

See Appendix I

OTHER PREFIXES:

See Instruments Covered by Manual, Section I

NOTE

For Serial Numbers 906-00526 and above see Manual CHANGE SHEET. For Serial Numbers 906-00525 and below see Appendix I.

© Copyright HEWLETT-PACKARD COMPANY 1989
1400 FOUNTAIN GROVE PARKWAY, SANTA ROSA, CA 95401 U.S.A.

MANUAL PART NO. 08745-90009
Microfiche Part No. 08745-90011

Printed: FEBRUARY 1982



TABLE OF CONTENTS

Section	Page	Section	Page
I GENERAL INFORMATION	1-1	III OPERATION (Cont'd)	
1-1. Description	1-1	3-10. S-Parameter Measurement	3-1
1-5. Accessories Furnished	1-1	3-11. General Measurement Description	3-1
1-7. Rack Mounting Kit	1-1	3-13. Semiconductor Bias Supply Connection and Adjustment	3-7
1-9. Thirty-Six Pin Male Connector	1-1	3-18. Increased Accuracy by Minimizing Directivity Errors	3-18
1-11. Sub-Deck Extension	1-1	3-23. Calibrating out the Reflection of the Transistor Fixture	3-19
1-13. Accessories Available	1-1	3-26. Remote S-Parameter Selection	3-20
1-14. Transistor Fixtures	1-1	3-33. Care of APC-7 Connectors	3-21
1-16. Calibrators	1-1	3-36. Contact Replacement	3-21
1-18. Universal Extension	1-1	3-41. Coupling Mechanisms	3-22
1-20. Quick Connect Adapter	1-1	3-43. Power Switch Lamp Replacement	3-22
1-22. Accessory Kit to Connect Model 8405A to Model 8745A	1-1	IV MAINTENANCE	4-1
1-24. Complementary Equipment	1-3	4-1. Introduction	4-1
1-25. Model 8410A Network Analyzer	1-3	4-3. Performance Testing	4-1
1-27. Model 8405A Vector Voltmeter	1-3	4-4. Procedures	4-1
1-29. Model 8717A Transistor Power Supply	1-3	4-6. Test Equipment Required	4-1
1-31. Model 8690B Sweep Oscillator Mainframe with 8699B Plug-In	1-3	4-8. Adjustments	4-1
1-33. Model 3200B VHF Oscillator	1-3	4-10. Troubleshooting	4-1
1-35. Model 11607A Small Signal Adapter	1-3	4-11. Test Equipment Required	4-1
1-37. Instruments Covered by Manual	1-3	4-13. Procedures	4-1
II INSTALLATION	2-1	4-17. Transistor Testing	4-1
2-1. Incoming Inspection	2-1	4-21. Repair Procedures	4-3
2-3. Repackaging for Shipment	2-1	4-23. Printed Circuit Boards	4-3
2-4. Using Original Packaging	2-1	4-29. RF Source Relay (A11) Replacement	4-4
2-8. Using Other Packaging	2-1	4-32. RF Source Relay (A9 or A10) Replacement	4-4
2-10. Preparation for Use	2-1	4-35. Directional Coupler (DC1 and DC2) Replacement	4-5
2-11. Rear-Panel Coaxial Link	2-1	4-39. Line Stretcher (A6) Replacement	4-6
2-13. Power Requirements	2-1	4-42. RF Connector Repair	4-7
2-15. 115/230 Volt Operation	2-1	V REPLACEABLE PARTS	5-1
2-18. Power Cable	2-2	5-1. Introduction	5-1
2-21. Bench Operation	2-2	5-4. Ordering Information	5-1
2-23. Rack Mounting	2-2	VI SCHEMATIC DIAGRAMS	6-1
III OPERATION	3-1	6-1. Introduction	6-1
3-1. Introduction	3-1	APPENDIX I	I-1
3-3. Description of Panel Features	3-1		
3-5. Operating Precautions	3-1		
3-6. Maximum RF Power	3-1		
3-8. Maximum DC on RF Lines	3-1		

LIST OF ILLUSTRATIONS

Number	Title	Page	Number	Title	Page
1-1.	Model 8745A S-Parameter Test Set and Accessories	1-0	3-7.	Simplified Internal Bias Circuit	3-7
3-1.	Front Panel Features	3-2	3-8.	Correct Position of Snap-on Dial when Using Calibrator	3-8
3-2.	Rear Panel Features	3-3	3-9.	Bias Supply Connections for Bipolar and FET Transistors	3-9
3-3.	Signal Flow Diagrams, Input Port A Selected	3-4	3-10.	Semiconductor Measurement with 8405A Vector Voltmeter Readout	3-10
3-4.	Signal Flow Diagrams, Input Port B Selected	3-5	3-11.	Semiconductor Measurement with 8410A Network Analyzer Readout	3-12
3-5.	Block Diagram of Equipment Setup for S-Parameter Measurement	3-6	3-12.	Microwave Hardware Measurements with 8405A Vector Voltmeter Readout	3-14
3-6.	HP Model 8717A Transistor Bias Supply	3-6	3-13.	Microwave Hardware Measurements with 8410A Network Analyzer Readout	3-16

Number	Title	Page
3-14.	Typical Polar Plot Showing Measured Reflection as the Sum of Directivity and Load Vectors	3-18
3-15.	Typical Polar Plot Showing Locus of Measured Reflection when Sliding Load is Moved	3-18
3-16.	Polar Display Showing Locus of Sliding Load Vector with Directivity Cancelled	3-18
3-17.	Typical Polar Plot Showing Method of Separating Load Vector from Directivity Vector when Directivity Vector is Larger than Load Vector	3-19
3-18.	Typical Polar Plot Showing Method of Separating Load Vector from Directivity Vector when Directivity Vector is Smaller than Load Vector	3-19
3-19.	Typical Polar Plot Showing Graph Method of Cancelling Directivity	3-20
3-20.	Typical Polar Plot Showing Measured Transistor Reflection as the Sum of Fixture and Transistor Reflections	3-20
3-21.	Typical Remote Contact Closure Circuit	3-22
3-22.	APC-7 Connectors	3-23
3-23.	Pushbutton Lamp Replacement	3-24
4-1.	Transistor Biasing Characteristics	4-1
4-2.	REFERENCE and TEST Channel Output and Coaxial Link Connectors Exploded View	4-8
4-3.	Performance Test	4-10
4-4.	General Troubleshooting	4-17
4-5.	Relay Troubleshooting	4-19
4-6.	Test Relay Troubleshooting	4-21
4-7.	RF Section Troubleshooting	4-23
4-8.	Digital Counter Friction Clutch Adjustment	4-25
5-1.	Cabinet Parts	5-8
5-2.	Front Panel Assy	5-9
5-3.	Line Stretcher Assy Parts	5-10
5-4.	REFERENCE and TEST Channel Output and Coaxial Link Connector Parts	5-11
6-1.	General Information on Schematic Diagrams	6-1
6-2.	Schematic Diagram Notes	6-2
6-3.	8745A Component Identification, Top View, Units not Equipped with Rear-Panel Coaxial Link	6-3
6-4.	8745A Component Identification, Top View, Units Equipped with Rear-Panel Coaxial Link	6-4

Number	Title	Page
6-5.	Simplified Schematic Diagram, RF Section	6-5
6-6.	Schematic Diagram, RF Section	6-5
6-7.	Relay Control Section Circuit Descriptions	6-7
6-8.	Block Diagram, Relay Control Section	6-7
6-9.	A3 Relay Driver Assembly Component Identification for S-Parameter Latches, Serial Numbers Prefixed 823-	6-8
6-10.	A3 Relay Driver Assembly Component Identification for S-Parameter Latches, Serial Numbers Prefixed 906- and Above	6-9
6-11.	Relay Control Section Schematic Diagram, S-Parameter Selectors and Latching Circuits	6-9
6-12.	A3 Relay Driver Assembly Component Identification for Inverters and Remote S-Parameter Select Decoder, Serial Numbers Prefixed 823-	6-10
6-13.	A3 Relay Driver Assembly Component Identification for Inverters and Remote S-Parameter Select Decoder, Serial Numbers Prefixed 906- and Above	6-11
6-14.	Relay Control Section Schematic Diagram, Inverters, and Remote S-Parameter Select Decoder	6-11
6-15.	A3 Relay Driver Assembly Component Identification for OR-Gate, AND-Gate and Relay Drivers, Serial Numbers Prefixed 823-	6-12
6-16.	A5 Bias Filter Assembly Component Identification, Serial Numbers Prefixed 823-	6-12
6-17.	A5 Bias Filter Assembly Component Identification, Serial Numbers Prefixed 906- and Above	6-12
6-18.	A3 Relay Driver Assembly Component Identification for OR-Gate, AND-Gate and Relay Drivers, Serial Numbers Prefixed 906- and Above	6-13
6-19.	Relay Control Section Schematic Diagram, Relay Drivers, RF Relays and Bias Filter	6-13
6-20.	A2 Power Supply Assembly Component Identification	6-15
6-21.	A4 Interconnect Assembly Component Identification	6-15
6-22.	Relay Control Section Schematic Diagram, Power Supply	6-15

LIST OF TABLES

Number	Title	Page
1-1.	Specifications	1-2
3-1.	Remote Input (J1) Connector Contact Identification	3-8
3-2.	Calibration Readout Values	3-8
3-3.	Signal Requirements for Remote S-Parameter Selection	3-21
4-1.	Out-of-Circuit Transistor Resistance Measurements	4-2
4-2.	Safe Ohmmeter Resistance Ranges for Transistor Measurements	4-2
4-3.	Printed Circuit Soldering Equipment	4-3

Number	Title	Page
4-4.	Recommended Test Equipment	4-9
4-5.	Performance Test Record	4-16
5-1.	Reference Designation Index	5-2
5-2.	Replaceable Parts	5-12
5-3.	Code List of Manufacturers	5-14
6-1.	Test Point Voltages for S-Parameter Latches	6-9
6-2.	Test Point Voltages for Inverters and Remote S-Parameter Select Decoder	6-11
6-3.	Test Point Voltages for OR-Gate, AND-Gate, and Relay Drivers	6-13



8745A

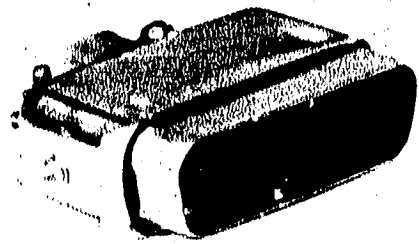

36-PIN CONNECTOR

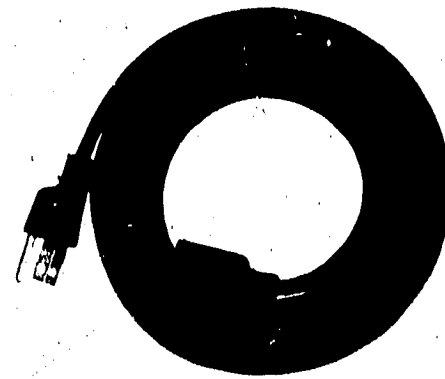

POWER CABLE

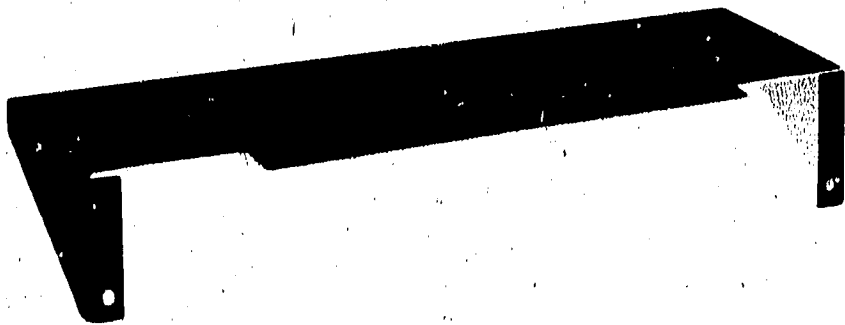

SUB-DECK EXTENSION

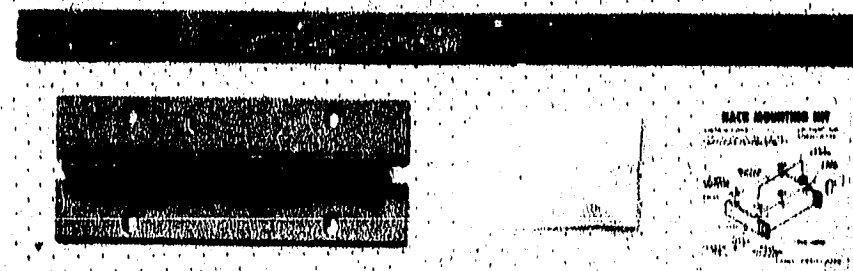

RACK MOUNTING KIT

Figure 1-1. Model 8745A S-Parameter Test Set and Accessories.

SECTION I GENERAL INFORMATION

1-1. DESCRIPTION.

1-2. The Model 8745A S-Parameter Test Set contains the necessary microwave circuits for measuring s parameters from 0.1 to 2.0 GHz. It is designed to be used with a compatible phase-amplitude ratio indicator, such as the Model 8410A Network Analyzer or Model 8405A Vector Voltmeter. The measuring circuits for each s parameter are automatically set up with a front-panel pushbutton or with remote contact closures.

1-3. The s parameters of almost any device, such as a microwave component or a transistor, can be measured using one of the accessory fixtures. For transistor measurement, terminals are provided to apply dc bias. An accessory quick-connect adapter allows fixtures to be connected and disconnected from the 8745A with quick, simple lever action.

1-4. A built-in, calibrated line stretcher simplifies initial phase calibration and allows the plane of measurement to be extended beyond the 8745A terminals.

1-5. ACCESSORIES FURNISHED.

1-6. A rack-mounting kit, a male 36-pin connector (HP Part Number 1251-0084), a detachable power cable, and a platform to extend the sub-deck are furnished with the Model 8745A (see Figure 1-1).

1-7. RACK MOUNTING KIT.

1-8. The rack mounting kit contains all the hardware needed to adapt the Model 8745A cabinet for installation in equipment racks with standard 19-inch spacing. Instructions for conversion to rack mounting are included with the kit.

1-9. THIRTY-SIX PIN MALE CONNECTOR.

1-10. The 36-pin male connector mates with the rear-panel REMOTE INPUT connector, and permits all necessary remote programming and bias connections to be made to the 8745A. (See Table 3-1 for wiring information.)

1-11. SUB-DECK EXTENSION.

1-12. The sub-deck extension extends the sub-deck which supports the 8411A Harmonic Frequency Converter of the 8410A Network Analyzer. The sub-deck extension prevents strain on the connectors when attenuators are used between the 8411A and 8745A.

1-13. ACCESSORIES AVAILABLE.

1-14. TRANSISTOR FIXTURES.

1-15. The Models 11600A,B and 11602A,B Transistor Fixtures provide a convenient and accurate way to hold transistors and many other devices when making s-parameter measurements from dc to 2.0 GHz. The 11600A,B accepts transistors with TO-18 and TO-72 base patterns, and has four snap-on dials, two for bipolar transistors and two for FET's. The 11602A,B accepts transistors with TO-5 and TO-12 base patterns. It has two snap-on dials for different types of bipolar transistors and provides for FET's without a dial. When a transistor fixture is used with the 8745A, transistor bias connections are made through the S-Parameter Test Set. The RF input and output connectors on the transistor fixtures mate with APC-7* style 50-ohm precision 7 mm sexless connectors.

1-16. CALIBRATORS.

1-17. Two calibrators, a short circuit termination and a 50-ohm through section, are furnished with the Model 11600B and 11602B Transistor Fixtures. A 50-ohm load is also available as an option on both models. These calibrators are used to calibrate the equipment setup for a known reference.

1-18. UNIVERSAL EXTENSION.

1-19. The Model 11604A Universal Extension is composed of four rotary joints and two rotary air lines. It allows the 8745A input port spacing to be adapted to almost any microwave component, providing the accuracy of rigid air line with the flexibility of cable. The two connectors which attach the Universal Extension to the 8745A mate with APC-7* style connectors and the two connectors that attach to the device under test are APC-7* style 50-ohm precision 7 mm sexless connectors. A coaxial link is included with the Universal Extension. The coaxial link replaces the 8745A rear-panel coaxial link to compensate for the Universal Extension's electrical length. **

1-20. QUICK CONNECT ADAPTER.

1-21. The Model 11599A Quick Connect Adapter connects and disconnects Model 11600-series transistor fixtures and the Model 11604A Universal Extension with the simple motion of a lever. In addition to saving time, this lever-action coupling eliminates wear on

* Amphenol RF Division, Danbury, Connecticut.

** For test units equipped with rear-panel coaxial link.

Table 1-1. Specifications

<p>Frequency Range:</p> <p>100 MHz to 2 GHz. Can be used below 100 MHz since coupler directivity remains above 36 dB.</p> <p>Impedance:</p> <p>50 ohms nominal.</p> <p>Directivity:</p> <p>Below 1 GHz, >36 dB; 1-2 GHz, >32 dB in an environment of 10° to 30°C and 30 to 60% relative humidity for 24 hours.</p> <p>Coupling:</p> <p>Above 120 MHz, 20 dB nominal; below 120 MHz, rolls off at 6 dB/octave.</p> <p>Insertion Loss:</p> <p>From RF input to test ports, 4 dB nominal.</p> <p>From test ports to 8405A or 8410A outputs, 20 dB nominal.</p> <p>Load Match¹:</p> <p>Reflection coefficient (VSWR)</p> <p><0.10 (<1.22), 100-200 MHz.</p> <p><0.063 (<1.13), 200-2000 MHz.</p> <p>Source Match²:</p> <p>Effective reflection coefficient (VSWR)</p> <p><0.057 (<1.12), 0.11-2.0 GHz.</p> <p>Maximum RF Power:</p> <p>2 Watts.</p>	<p>Connectors:</p> <p>RF Input: Type N female.</p> <p>Test Ports: APC-7³ precision connectors.</p> <p>Outputs to 8405A or 8410A: Mates with APC-7³ precision connectors.</p> <p>Option 001, Type N female (for use with 8405A Vector Voltmeter).</p> <p>Reference Plane Extension:</p> <p>Maximum length 30 cm, 0.01 cm precision. Extends reference plane 0 to 15 cm.</p> <p>Microwave Coax Switches:</p> <p>Typical switching time, 40 msec.</p> <p>Estimated switch lifetime > 1 million cycles.</p> <p>Remote Programming:</p> <p>Remote s parameter selection by closing 2 contacts of 36-pin rear panel connector to common pin. Contact is at 12 volts and short to common will draw 12 mA.</p> <p>Transistor Biasing:</p> <p>Bias and bias sensing connections are made to the biasing networks built into the 8745A via the 36-pin rear panel connector.</p> <p>Maximum Bias:</p> <p>100V dc (50V dc on instruments with serial number prefixed 823-); 1.0 amp.</p> <p>Storage Temperature: 0° to 55°C.</p> <p>Power:</p> <p>115 or 230V ±10%, 50 to 400 Hz, 50 VA</p> <p>Weight:</p> <p>35 lb. (15, 9 kg).</p> <p>Dimensions:</p> <p>5-1/2 x 16-3/4 x 25-3/4 inches (139 x 423 x 650mm).</p>
<p>¹ Load Match: Reflection coefficient of the port used to terminate the device under test.</p> <p>² Source Match: Effective Reflection coefficient of the port used to supply incident signal to the device under test. A function of directivity and main line VSWR of coupler monitoring incident signal, and not a function of signal source VSWR.</p> <p>³ APC-7® is a registered trademark of Bunker Ramo Corporation.</p>	

connector coupling mechanisms. Two permanently-attached, hand-tightened screws fasten the adapter in place over the input port connectors of the test set. A plug-in slide that supports and aligns the transistor fixtures and a wrench for adjusting coupling action are supplied with the adapter.

1-22. ACCESSORY KIT TO CONNECT MODEL 8405A TO MODEL 8745A.

1-23. The Model 11570A Accessory Kit includes one Model 11549A Power Splitter (used to make initial calibration of 8405A), two 11536A 50-ohm Tees, and two 908A Terminations. In addition to the 11570A Accessory Kit, two Model 11524A APC-7 to female type N adapters are required to make connections to the 8745A.

1-24. COMPLEMENTARY EQUIPMENT.

1-25. MODEL 8410A NETWORK ANALYZER.

1-26. The 8410A Network Analyzer measures relative amplitude and phase of two RF input signals. The instrument is capable of single- or swept-frequency measurements in the range of 0.11 to 12.4 GHz. Two plug-in display units are available. The 8413A plug-in unit displays relative amplitude and phase data on a meter. Phase and amplitude output signals allow display of swept signals on an oscilloscope or X-Y recorder. The 8414A plug-in unit displays relative amplitude and phase data in polar coordinates on a 5-inch CRT for either swept or CW measurements.

1-27. MODEL 8405A VECTOR VOLTMETER.

1-28. The 8405A Vector Voltmeter measures magnitude and phase at single frequencies in the range of 1.0 MHz to 1.0 GHz. Signal magnitude and phase are displayed on separate meters.

1-29. MODEL 8717A TRANSISTOR POWER SUPPLY.

1-30. The 8717A Transistor Power Supply is designed especially for use with the 8745A S-Parameter Test Set and the 11600A, B and 11602A, B Transistor Fixtures. This programmable supply provides bias levels for the semiconductor devices tested in the fixtures. Feedback circuits within the supply provide

very stable bias conditions. Overload protection for the device under test is selectable. Maximum current is 500 mA and maximum voltage is 30 Vdc.

1-31. MODEL 8690B SWEEP OSCILLATOR MAIN-FRAME WITH 8699B PLUG-IN.

1-32. The entire range of the 8745A is covered in one sweep range of the 8699B plug-in. The 8699B has a low range from 0.1 to 2.0 GHz and a high range from 2 to 4 GHz.

1-33. MODEL 3200B VHF OSCILLATOR.

1-34. The 3200B VHF Oscillator with the 13515A Frequency Doubler Probe is a CW RF signal source covering the 10 MHz to 1.0 GHz range and is an ideal source to use with the 8405A Vector Voltmeter and the 8745A.

1-35. MODEL 11607A SMALL-SIGNAL ADAPTER.

1-36. The Hewlett-Packard Model 11607A Small-Signal Adapter is an accessory for the Hewlett-Packard Model 8745A S-Parameter Test Set. This Adapter reduces the signal incident on the device under test 20 dB for small-signal measurements on devices under test, such as transistors.

1-37. INSTRUMENTS COVERED BY MANUAL.

1-38. This manual applies directly to instruments having serial numbers prefixed 978- (first three numbers of serial number). If the serial prefix of your instrument is other than 978-, there are differences between the instrument described in this manual and your instrument. These differences are described in the appendix at the rear of this manual for lower number prefixes. For higher prefixes the differences are described in a Manual Changes sheet supplied with this manual. If the manual changes sheet is missing, the information can be supplied by your nearest Hewlett-Packard Sales and Service Office (see lists at the rear of this manual). The manual changes sheet may also include an "ERRATA" section which describes manual correction information which applies to the manual for all instruments INCLUDING instruments prefixed 978-.

SAFETY CONSIDERATIONS

GENERAL

This product and related documentation must be reviewed for familiarization with safety markings and instructions before operation. This product has been designed and tested in accordance with international standards.

SAFETY SYMBOLS



Instruction manual symbol: the product will be marked with this symbol when it is necessary for the user to refer to the instruction manual (refer to Table of Contents).



Indicates hazardous voltages.



Indicates earth (ground) terminal.

WARNING

The **WARNING** sign denotes a hazard. It calls attention to a procedure, practice, or the like, which, if not correctly performed or adhered to, could result in personal injury. Do not proceed beyond a **WARNING** sign until the indicated conditions are fully understood and met.

CAUTION

The **CAUTION** sign denotes a hazard. It calls attention to an operating procedure, practice, or the like, which, if not correctly performed or adhered to, could result in damage to or destruction of part or all of the product. Do not proceed beyond a **CAUTION** sign until the indicated conditions are fully understood and met.

SAFETY EARTH GROUND

This is a Safety Class I product (provided with a protective earthing terminal). An uninterruptible safety earth ground must be provided from the main power source to the product input wiring terminals, power cord, or supplied power cord set. Whenever it is likely that the protection has been impaired, the product must be made inoperative and be secured against any unintended operation.

BEFORE APPLYING POWER

Verify that the product is configured to match the available main power source per the input power configuration instructions provided in this manual.

If this product is to be energized via an autotransformer make sure the common terminal is connected to the neutral (grounded side of mains supply).

SERVICING

WARNING

Any servicing, adjustment, maintenance, or repair of this product must be performed only by qualified personnel.

Adjustments described in this manual may be performed with power supplied to the product while protective covers are removed. Energy available at many points may, if contacted, result in personal injury.

Capacitors inside this product may still be charged even when disconnected from its power source.

To avoid a fire hazard, only fuses with the required current rating and of the specified type (normal blow, time delay, etc.) are to be used for replacement.

SECTION II INSTALLATION

2-1. INCOMING INSPECTION.

2-2. Inspect instrument for shipping damage as soon as it is unpacked. Check that all accessories listed in Paragraph 1-5 have been included. Check for broken knobs and connectors; inspect cabinet and panel surfaces for dents and scratches. If the instrument is damaged in any way or fails to operate properly, notify the carrier and your nearest Hewlett-Packard Sales and Service Office. For assistance of any kind, including instruments under warranty, contact the nearest Hewlett-Packard Sales and Service Office.

2-3. REPACKAGING FOR SHIPMENT.

2-4. USING ORIGINAL PACKAGING.

2-5. The same containers and materials used in factory packaging can be obtained through the Hewlett-Packard offices listed at the rear of this manual. For units equipped with a rear-panel coaxial link, remove the coaxial link, wrap it separately, and include it in the shipping container.

2-6. If the Model 8745A is being returned to Hewlett-Packard for servicing, attach a tag indicating the type of service required, return address, model number, and full serial number. Also, mark the container **FRAGILE** to assure careful handling.

2-7. In any correspondence, refer to the instrument by model number and full serial number.

2-8. USING OTHER PACKAGING.

2-9. The following general instructions should be used when repackaging with commercially-available materials:

a. Wrap the instrument in heavy paper or plastic. For units equipped with a rear-panel coaxial link, remove the coaxial link, wrap it separately, and include it in the shipping container. If shipping to a Hewlett-Packard service office or center, attach a tag indicating the type of service required, the return address, model number, and full serial number.

b. Use a strong shipping container. A double-wall carton made of 350 pound test material is adequate.

c. Use enough shock-absorbing material (3 to 4 inch layer) around all sides of the instrument to provide cushion and prevent movement inside the container. Protect the control panel with cardboard.

d. Seal the shipping container securely, and mark it **FRAGILE** to assure careful handling.

e. In any correspondence refer to the instrument by model number and full serial number.

2-10. PREPARATION FOR USE.

2-11. REAR-PANEL COAXIAL LINK.

2-12. For units equipped with a rear-panel coaxial link, connect the coaxial link to the rear panel as shown in Figure 3-2. If a Model 11604A Universal Extension is to be used with the 8745A, connect the rear-panel coaxial link received with the Universal Extension.

2-13. POWER REQUIREMENTS.

2-14. The Model 8745A requires a power source of 115 or 230 volts ac $\pm 10\%$, 50 to 1000 Hz, single phase that can supply approximately 40 watts.

2-15. 115/230 VOLT OPERATION.

2-16. A two-position slide switch on the rear panel of the Model 8745A permits operation from either a 115- or 230- volt power source. The number showing on the switch slider indicates the voltage for which the instrument is connected. The correct line fuse rating for each line voltage is marked on the plate adjacent to the fuse.

2-17. To prepare the Model 8745A for operation, position the 115-230 volt switch so that the number showing on the slider corresponds to the available line voltage, and install a line fuse of correct rating. "Slo-blo" fuses should be used.

CAUTION

To avoid damage to the instrument, set the 115-230 switch to the line voltage to be used before connecting the power cable.

2-18. POWER CABLE.

2-19. To protect operating personnel, the National Electrical Manufacturers' Association (NEMA) recommends that instrument panels and cabinets be grounded. Accordingly, the Model 8745A is equipped with a three-conductor power cable which, when plugged into an appropriate receptacle, grounds panel and cabinet. The offset pin of the three-prong connector is the grounding pin.

2-20. To preserve the protection feature when operating the Model 8745A from a two-contact outlet, use a three-prong to two-prong adapter (HP Stock Number 1251-0048), and connect the green wire on the adapter to ground.

2-21. BENCH OPERATION.

2-22. The Model 8745A cabinet has plastic feet and a foldaway tilt stand for convenience in bench operation. The stand inclines the instrument enough to make the panel features easier to see. The plastic feet provide clearance for air circulation and make the Model 8745A self-aligning when stacked on other Hewlett-Packard full rack-width modular instruments.

2-23. RACK MOUNTING.

2-24. All necessary hardware and instructions are contained in the supplied rack-mounting kit (HP Stock Number 5060-0775). The ambient operating temperature should not exceed 55°C (140°F).

OPERATION

SECTION III OPERATION

3-1. INTRODUCTION.

3-2. The combination of the Model 8745A S-Parameter Test Set with its accessory fixtures and adapters, a signal source, and a compatible phase-amplitude ratio indicator, such as the Model 8410A Network Analyzer or Model 8405A Vector Voltmeter, make up a system to measure the parameters of almost any device. These measurements can be made at single frequencies or at swept frequencies from 0.1 to 2.0 GHz. When used with the HP Model 8405A Vector Voltmeter, measurements are limited to single frequencies and an upper frequency limit of 1.0 GHz. The Model 8745A can be used at frequencies below 100 MHz; however, the coupling attenuation of the internal directional couplers increases by approximately 6 dB per frequency octave. Consequently, when making measurements below 100 MHz the level of power delivered from the signal source should be monitored closely. Be sure power limits are not exceeded while trying to obtain sufficient indication on the readout instrument.

3-3. DESCRIPTION OF PANEL FEATURES.

3-4. Front and rear panel controls, connectors and indicators are described in Figures 3-1 and 3-2. In these figures the numbers on the panel illustrations match the description numbers.

3-5. OPERATING PRECAUTIONS.

3-6. MAXIMUM RF POWER.

3-7. Do not apply more than 2 watts of RF power to the Model 8745A RF INPUT. Power in excess of 2 watts may damage the internal 3 dB pad. Also care must be taken to ensure that the power returned to the Model 8745A from an active device under test does not exceed 2 watts or the 50-ohm terminations may be damaged.

3-8. MAXIMUM DC ON RF LINES.

3-9. DC voltage on the inner conductor of the transmission lines in the Model 8745A must not exceed ± 100 volts or the breakdown voltage of the internal bias blocking capacitor will be exceeded; therefore, the combination of dc voltage to bias a device under test and the dc voltage on the center conductor from the RF source must not exceed 100 volts (50 volts for instruments with serial prefixed 823- and below). The maximum dc current on the RF lines must not exceed 1.0 amp.

3-10. S-PARAMETER MEASUREMENT.

3-11. GENERAL MEASUREMENT DESCRIPTION.

3-12. The S-Parameter Test Set may be used to make s-parameter measurements with several combinations

of complementary equipment. A simplified block diagram of the test setup is shown in Figure 3-5. Readout is on a phase-amplitude ratio indicator such as the HP 8405A or the HP 8410A with 8413A or 8414A plug-in. Microwave components may be connected to the S-Parameter Test Set by accessories such as the 11600A,B or 11602A,B Transistor Fixture or the 11604A Universal Extension. Detailed procedures, using various combinations of equipment are given in Figures 3-10 through 3-13. The following general outline explains the steps necessary when making measurements with any combination of equipment.

a. If swept-frequency measurements are to be made, the reference and test channel line length between the device under test and the indicator unit must be equal. This is adjusted by the 8745A REFERENCE PLANE EXTENSION and, if necessary, additional line length can be inserted in the reference channel ahead of the 8411A. For units equipped with a removable rear-panel coaxial link, the link may be removed and additional reference channel electrical length may be installed to extend the reference plane any desired distance beyond the front-panel connectors. To best utilize the REFERENCE PLANE EXTENSION range, the following combinations are recommended: When making measurements with a transistor fixture use the short coaxial link (HP part number 08745-20064). When making microwave hardware measurements with the Universal Extension use the long coaxial link supplied with the Universal Extension (HP part number 11604-20021). When making microwave hardware measurements without a Universal Extension use either coaxial link and use a 20 cm air line instead of the Universal Extension. Correct adjustment of the reference and test channel electrical lengths is obtained when no linear phase shift occurs over a wide band of frequencies.

b. Calibrate the system for s-parameter measurement by terminating the input fixture with an open, a short, or a through section. Additional accuracy may be obtained by compensating for directivity error as described in Paragraph 3-18.

c. If a transistor fixture is used, the device under test must be properly biased by using either the HP 8717A Bias Supply or a standard dual dc power supply. Refer to Paragraph 3-13 for bias supply connections.

d. Measure the parameters of the device under test. This is accomplished by selecting input port A, or B then selecting the s parameter of interest. Figures 3-3 and 3-4 show the internal connections within the S-Parameter Test Set for the different switch combinations.

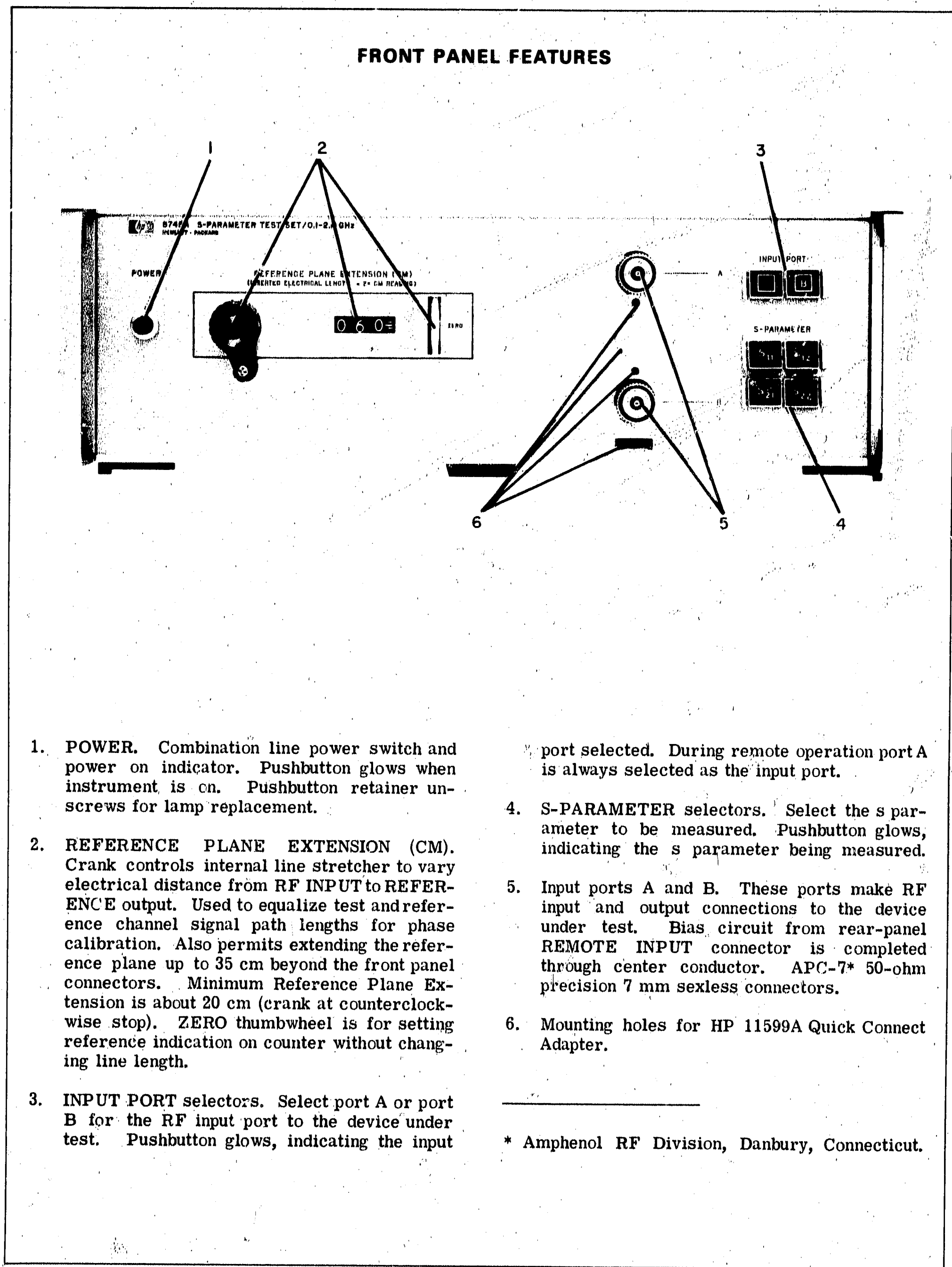

Figure 3-1. Front Panel Features

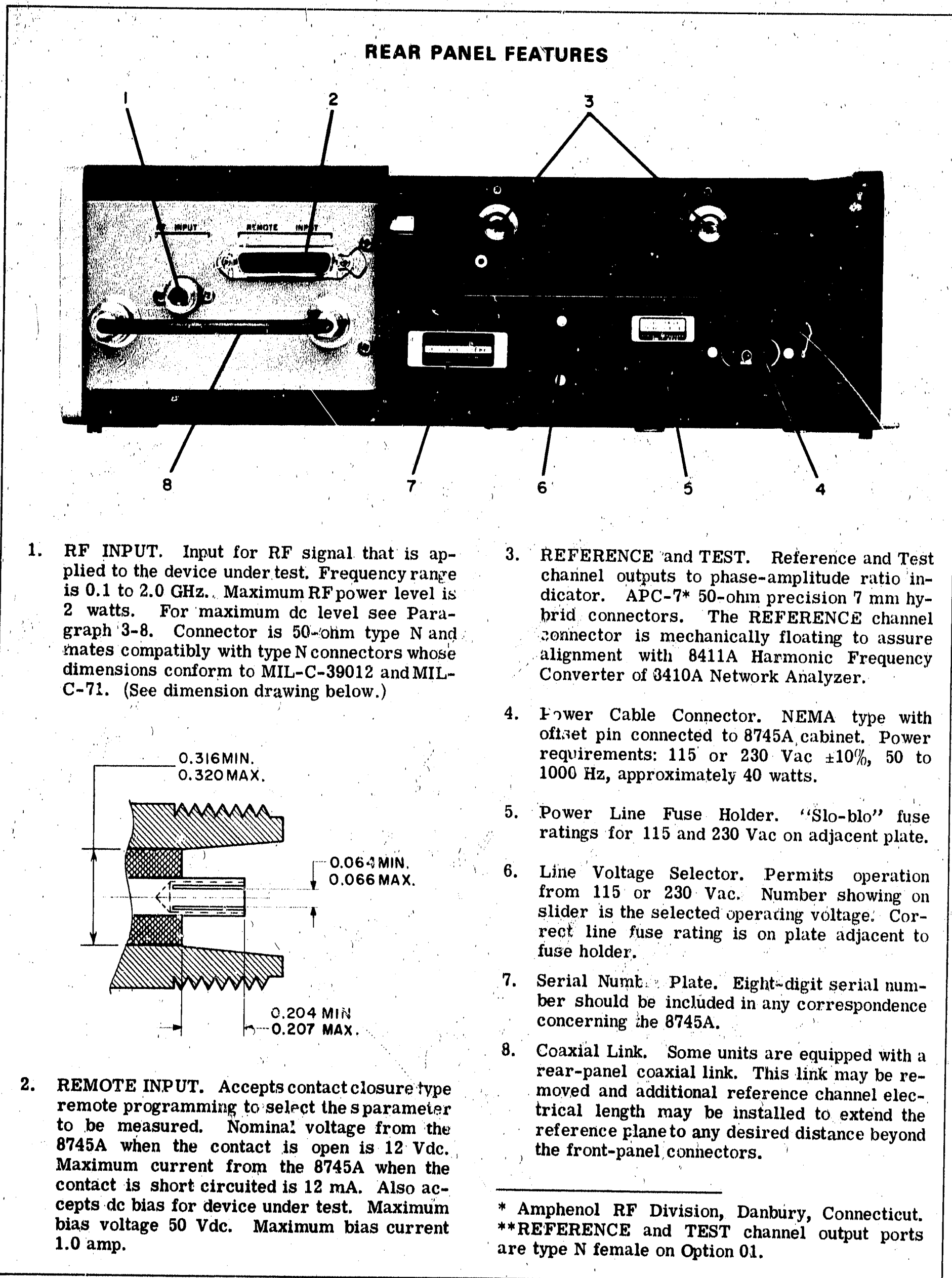

Figure 3-2. Rear Panel Features

PORT A SELECTED

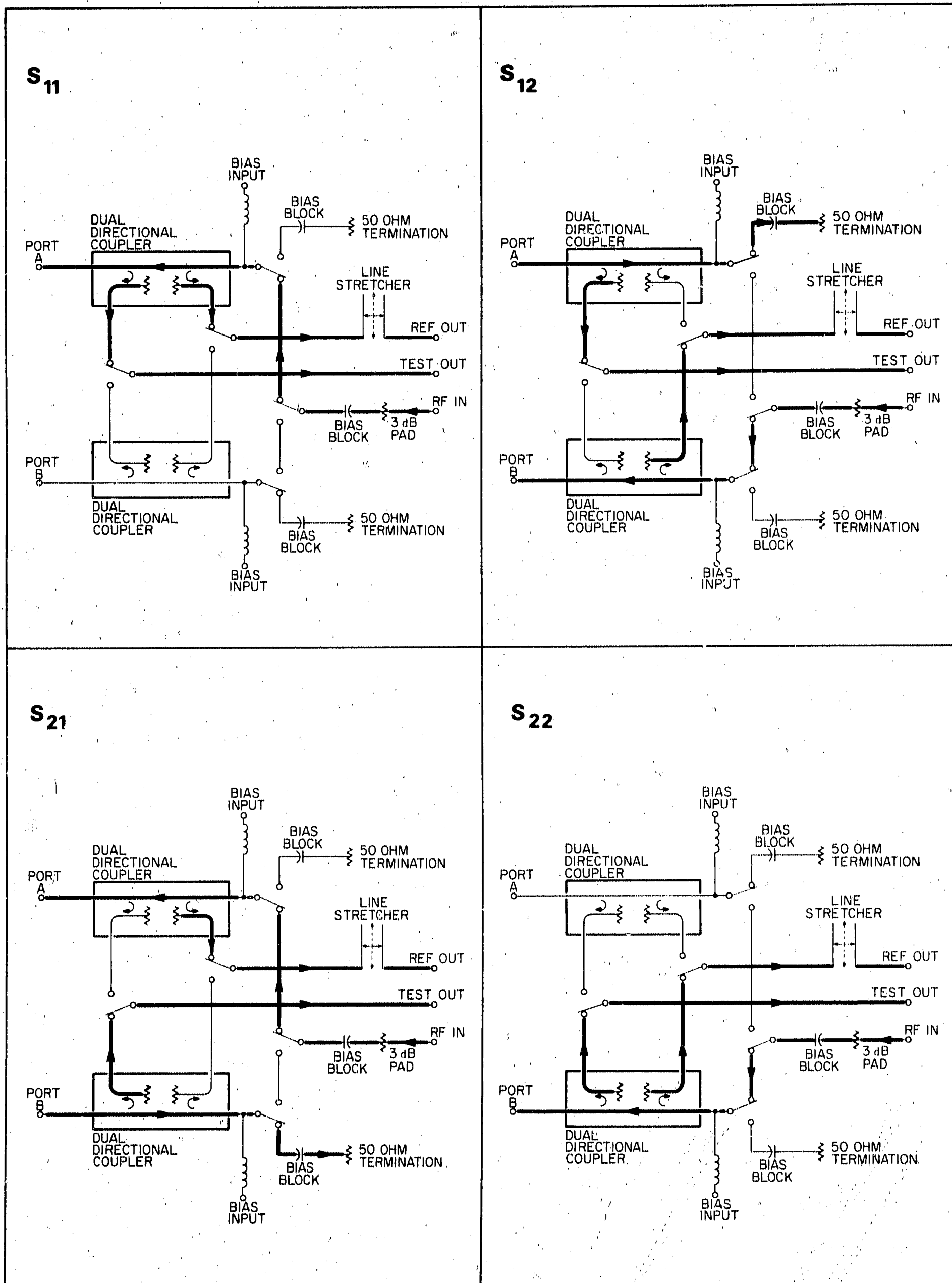

Figure 3-3. Signal Flow Diagrams, Input Port A Selected

PORT B SELECTED

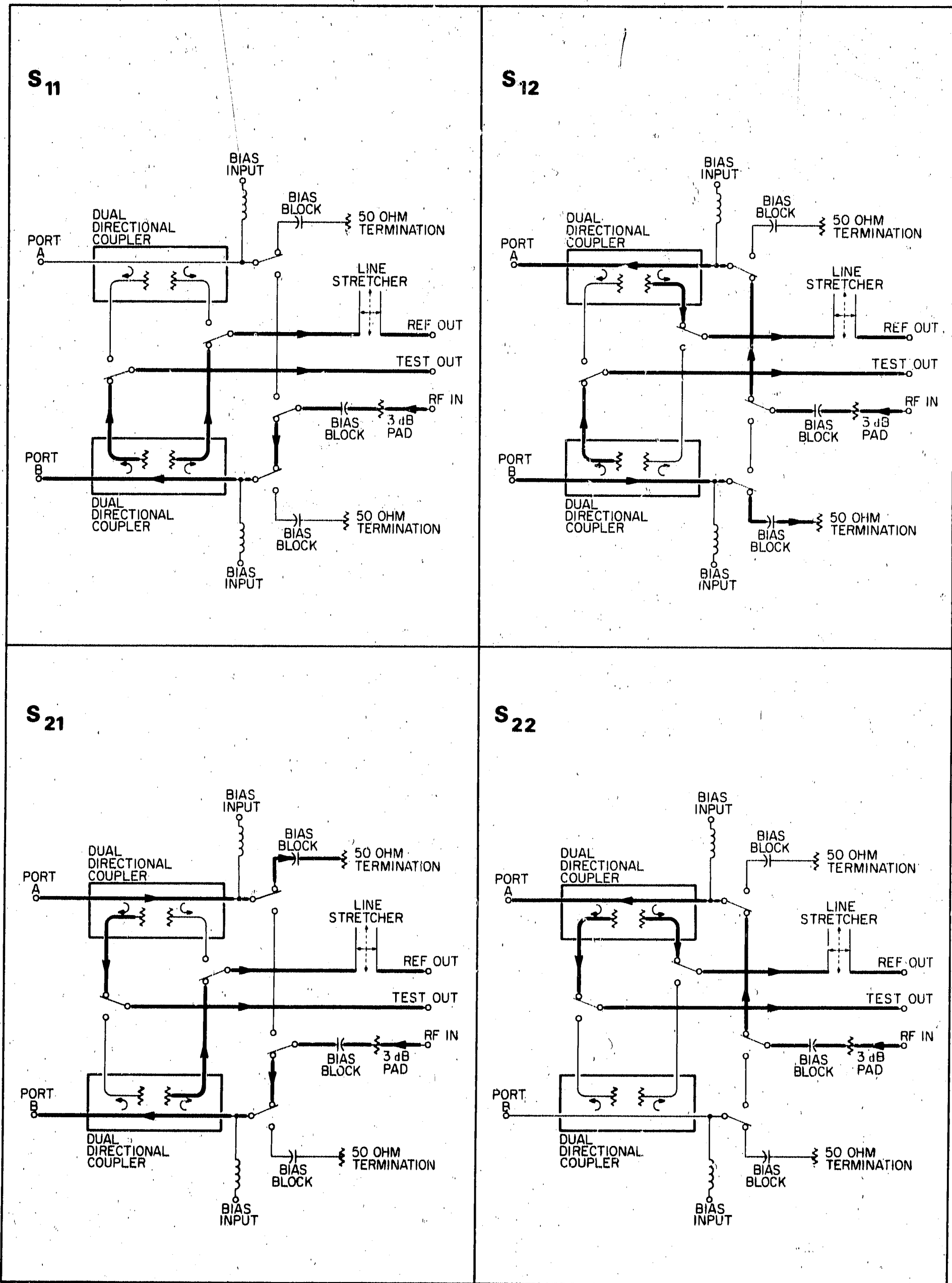

Figure 3-4. Signal Flow Diagrams, Input Port B Selected

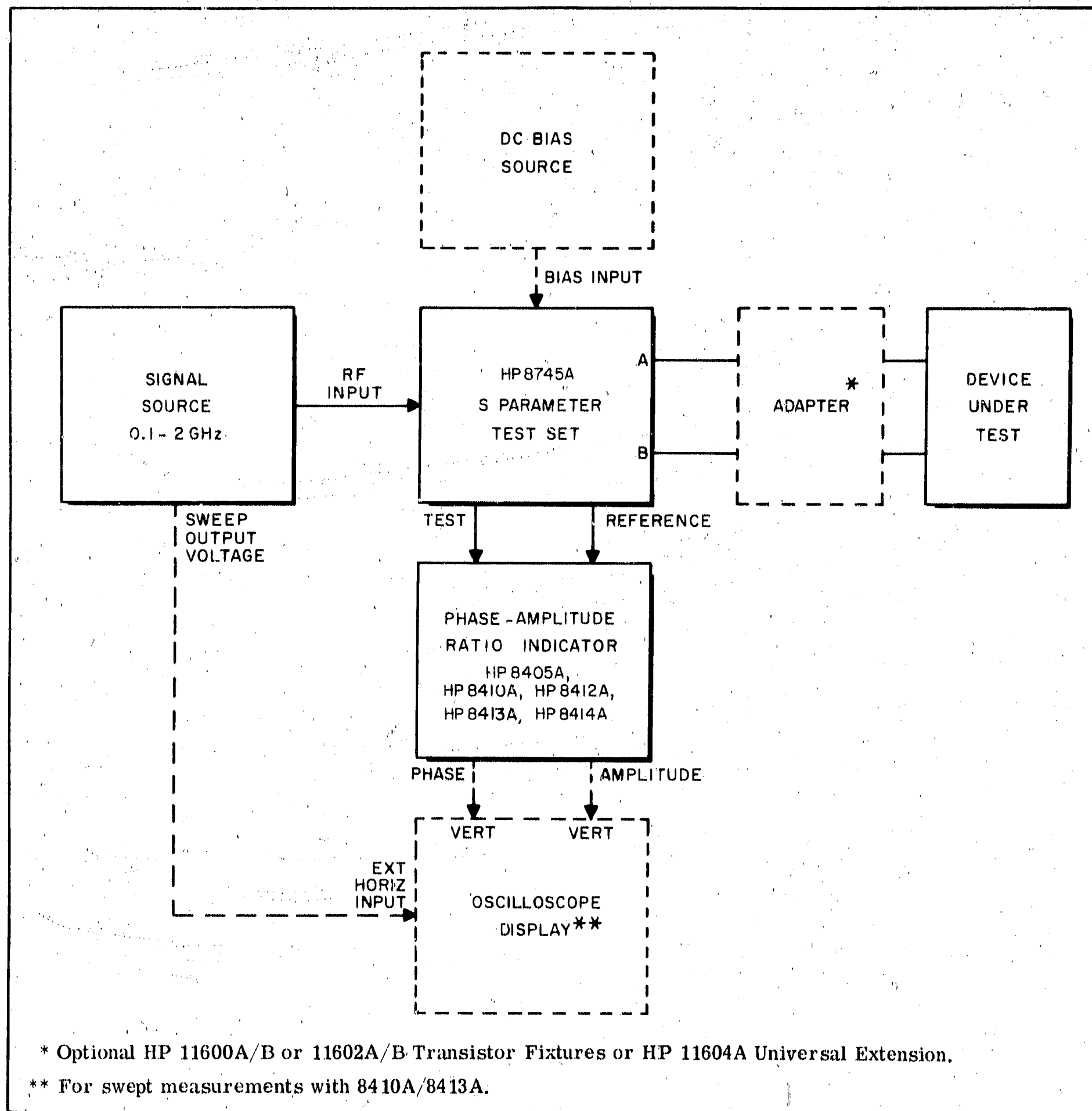

Figure 3-5. Block Diagram of Equipment Setup for S-Parameter Measurement

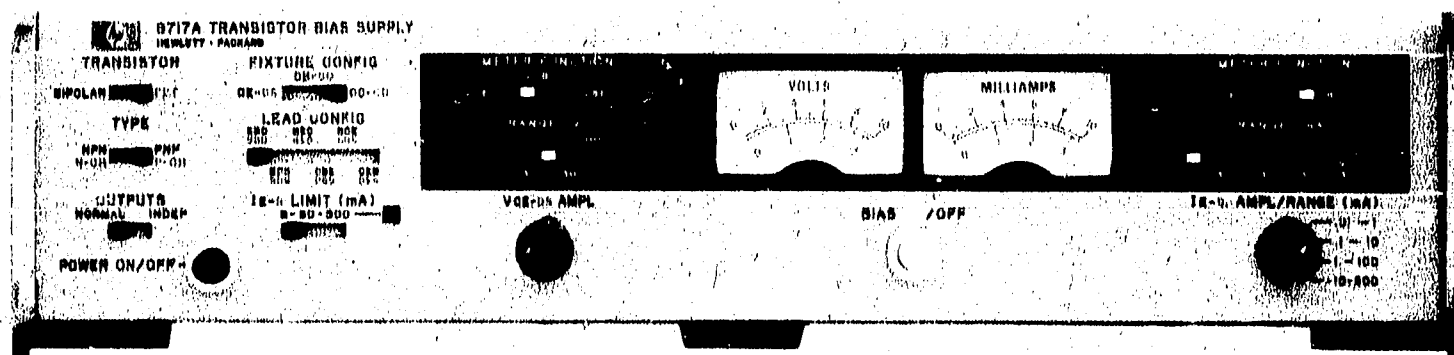

Figure 3-6. HP Model 8717A Transistor Bias Supply

3-13. SEMICONDUCTOR BIAS SUPPLY CONNECTION AND ADJUSTMENT.

3-14. A semiconductor under test may be biased by either a Model 8717A Transistor Bias Supply or by a dual dc power supply. Instructions for connecting and adjusting these power supplies are given in the following paragraphs. An 8745A simplified internal bias circuit is shown in Figure 3-7.

3-15. With the HP Model 8717A Transistor Bias Supply, bias and bias-sensing connections are selected with the 8717A front-panel switches, (see Figure 3-6.) A cable furnished with the 8717A connects the bias supply to the rear panel of the 8745A. To apply bias to the semiconductor under test, perform the following steps.

a. Make bias and sense connections from 8745A J1 (see Table 3-1) to 8717A output. Turn the 8717A bias output off.

b. Select the dial that matches the semiconductor under test and snap the dial on the transistor fixture.

If a diode is being tested, remove dial and insert diode into fixture in either shunt or series configuration.

c. Rotate the dial to the desired common lead configuration.

d. Set the 8717A front-panel switches for the same configuration.

e. Plug the semiconductor into the exposed holes in the fixture.

f. Turn the 8717A bias output on.

g. Set the 8717A voltage meter function switch to monitor V_{CE-DS} and adjust the V_{CE-DS} control to the desired collector-emitter or drain-source voltage for the semiconductor under test.

h. Set the 8717A current meter function switch to monitor I_{E-S} and adjust the I_{E-S} control to the desired emitter or source current. The maximum emitter or source current can be limited to 5, 50, or 500 mA.

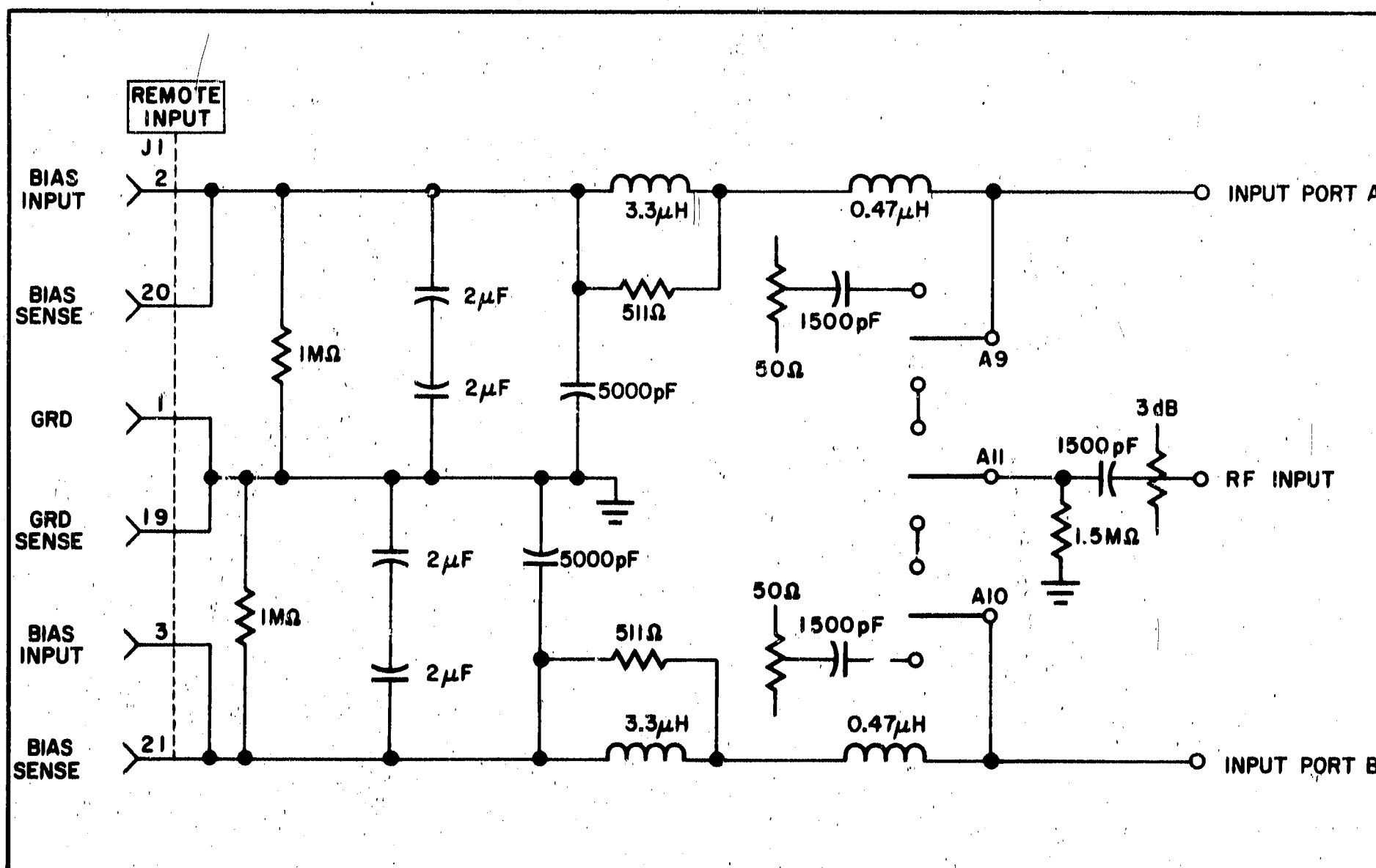

Figure 3-7. Simplified Internal Bias Circuit

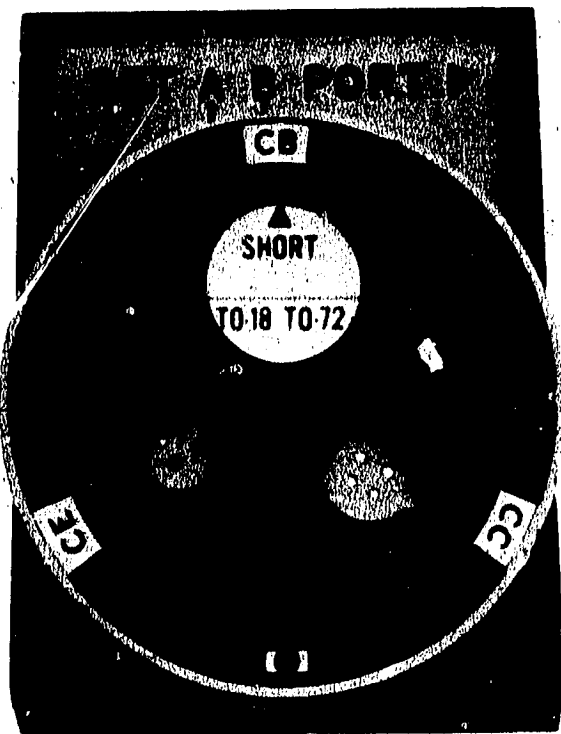

Figure 3-8. Correct Position of Snap-on Dial when Using Calibrator

3-16. Bias with a Dual dc Power Supply. Semiconductors may also be biased with a dual dc power supply. For this method a transistor under test can be protected against excessive current and excessive forward bias with a resistor and two diodes. Two series-connected diodes between emitter and base of a bipolar transistor as shown in Figure 3-9 will prevent the forward bias voltage from exceeding the voltage drop across the two diodes. A resistor in the emitter (source) circuit, selected to limit collector (drain) current to a safe amount, will also provide temperature stabilization of the bias point.

3-17. Connect the power supply to the 8745A as shown in Figure 3-9. To prevent ground loop problems do not connect power supply common to chassis. Adjust the power supply as follows:

- Set both power supplies to zero V dc.
- Select the dial that matches the semiconductor under test and snap the dial on the transistor fixture. If a diode is being tested, remove dial and insert diode into fixture in either shunt or series configuration.
- Rotate the dial to the desired common lead configuration.

d. Plug the semiconductor into the exposed holes.

e. Set supply No. 2 to obtain the desired collector-emitter (drain-source) voltage. If a stabilizing resistor is used, set supply to desired voltage plus the voltage drop across the stabilizing resistor.

f. Adjust supply No. 1 until the desired collector (drain) current is obtained. Recheck voltage set in step e. When operating with power applied to the semi-conductor over an extended period of time, supply No. 1 may have to be readjusted slightly to maintain the desired collector (drain) current.

Table 3-1. Remote Input (J1) Connector Contact Identification

Pin Number	Function
1	Chassis ground
2	Port A Bias
3	Port B Bias
6	Remote S Parameter Select
17	Remote Control Select
18	Remote Control Common
19	Chassis Ground Sense
20	Port A Bias Sense
21	Port B Bias Sense
24	Remote S Parameter Select
36	Remote control common
All others	No connection

Table 3-2. Calibration Readout Values

S-Parameter	Termination	Magnitude	Phase
S_{11} , S_{22}	Open	1	0°
S_{11} , S_{22}	Short	1	180°
S_{21} , S_{12}	Through Section	1	0°

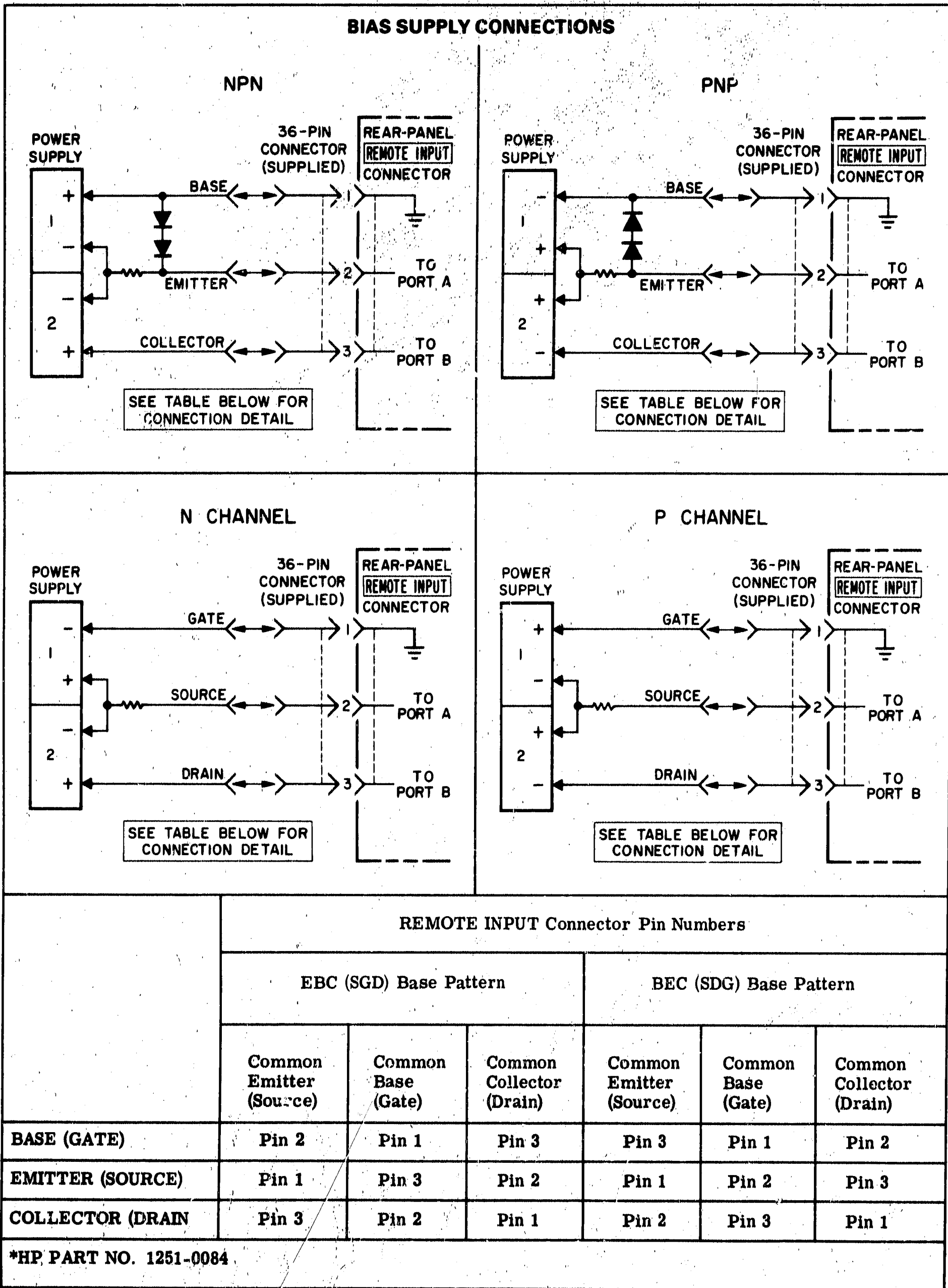

Figure 3-9. Bias Supply Connections for Bipolar and FET Transistors

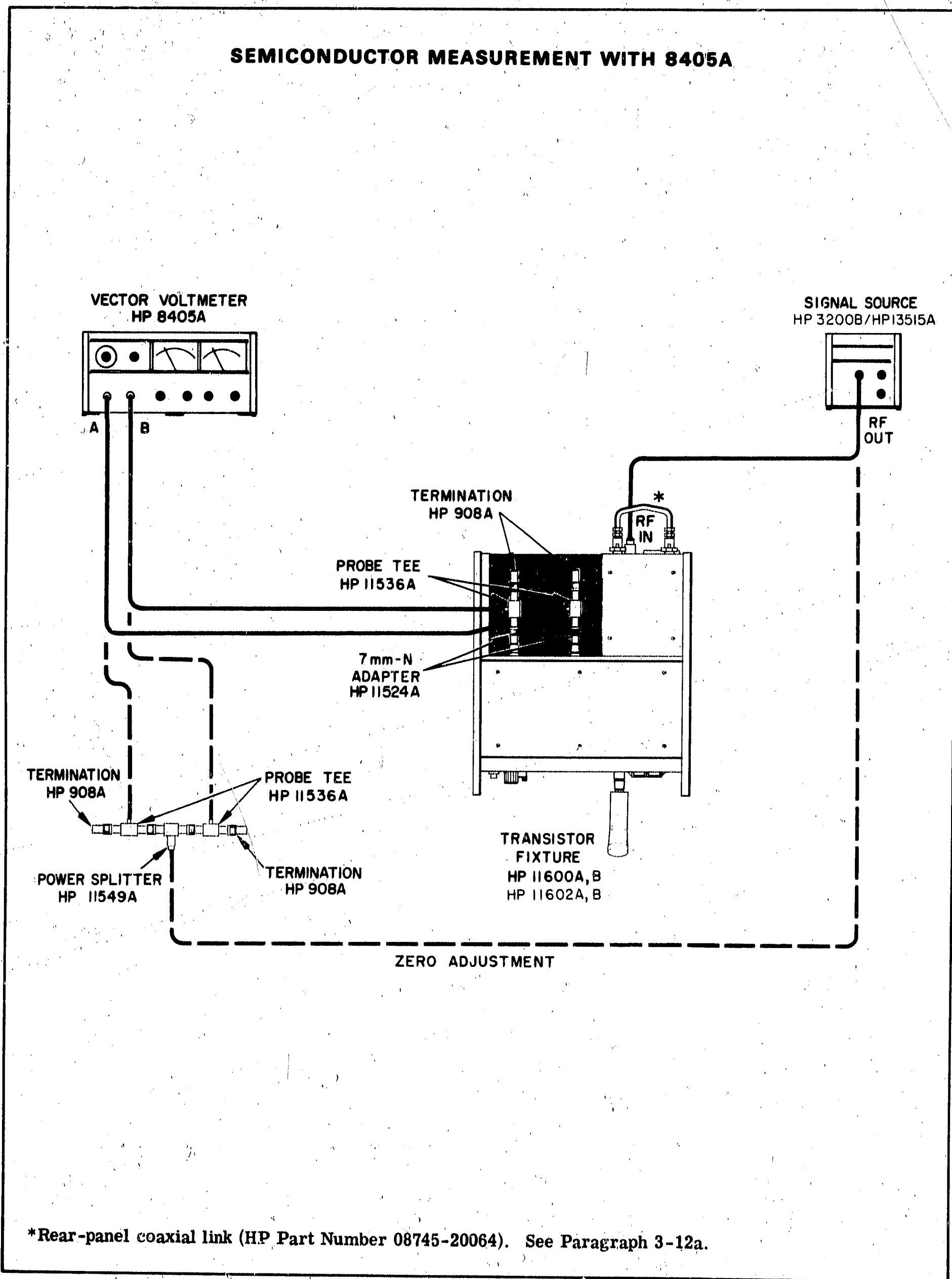

Figure 3-10. Semiconductor Measurement with 8405A Vector Voltmeter Readout (Sheet 1 of 2)

SEMICONDUCTOR MEASUREMENT WITH 8405A

CALIBRATION DESCRIPTION. Calibration consists of obtaining a reference indication using a termination of known magnitude and phase angle. Magnitude and phase reference indications for calibration are given in Table 3-2. An open circuit is obtained by not plugging anything into the transistor fixture. Calibrators, either a short, through section, or a 50-ohm load, may be used for more accurate calibration. If a calibrator is used, see Figure 3-8 for proper positioning of fixture snap-on dial and calibrator. For normal calibration, only one s parameter with only one of the known terminations is needed. Calibration for greater accuracy is discussed in Paragraph 3-18.

CALIBRATION PROCEDURE. To calibrate the system containing a transistor fixture and 8405A Vector Voltmeter readout, perform the following:

1. Connect equipment as shown in setup opposite. If measurements are to be made at more than one frequency, make zero adjustment of the Vector Voltmeter before connecting the probe tee's to the 8745A as follows:
 - a. Connect the signal source to the input port of the Model 11549A Power Splitter.
 - b. Connect the probe tee's to the two output ports of the power splitter. Terminate probe tee's with 908A 50-ohm loads.
 - c. Adjust the 8405A PHASE METER OFFSET to zero, and adjust PHASE ZERO for zero phase-meter reading.
 - d. Disconnect the RF cable and probe tee's from the power splitter. Connect the RF cable to the 8745A RF INPUT. Connect the probe tee's to the 8745A, Channel A to the REFERENCE output and Channel B to the TEST output.
2. Set the 8405A to phase lock to the applied signal.
3. Insert the calibrator to be used (Figure 3-8), and select the appropriate s parameter (See Table 3-2).
4. Adjust the signal source RF output to obtain a convenient Channel B voltage reference on the 8405A.

NOTE

For small signal measurements, adjust the signal source RF power for minimum signal level which will provide the desired dynamic range.

5. Note Channel A magnitude.
6. Adjust the 8745A REFERENCE PLANE EXTENSION for the reference indication of the calibrator selected (e.g., open circuit, press S_{11} or S_{22} , adjust for 0°). See Table 3-2.

The system is now calibrated for the frequency of the signal source. If measurements are to be made at more than one frequency, check for equal reference and test channel electrical lengths by changing the frequency of the signal source. If the electrical lengths are equal, the phase will not change with a change in frequency. To equalize the electrical lengths, adjust the 8405A PHASE ZERO to the appropriate phase reference indication at the lowest frequency, then adjust the 8745A REFERENCE PLANE EXTENSION for the same phase reference indication at the highest frequency of interest. Repeat these adjustments for minimum change in phase.

SEMICONDUCTOR BIASING. The semiconductor under test must be biased for a given collector-emitter or drain-source voltage and a given collector or drain current. The two voltages required may be furnished either by the HP Model 8717A Transistor Bias Supply, or by a dual dc power supply. Instructions for connecting either bias supply to the 8745A and adjusting it to bias the unit under test are given in Paragraph 3-13.

MEASUREMENT. To measure the s parameters of the semiconductor under test, perform the following:

1. Select INPUT PORT A or B as indicated on the transistor fixture.
2. Select the S PARAMETER to be measured.
3. Adjust the signal source RF output to return the 8405A Channel A signal to the magnitude noted in step 5 of the calibration procedure.
4. Compute the s parameter magnitude from

$$\text{Magnitude} = \frac{\text{measured channel B voltage}}{\text{reference channel B voltage}}$$

5. Read the phase directly on the 8405A phase meter.

Figure 3-10. Semiconductor Measurement with 8405A Vector Voltmeter Readout (Sheet 2 of 2)

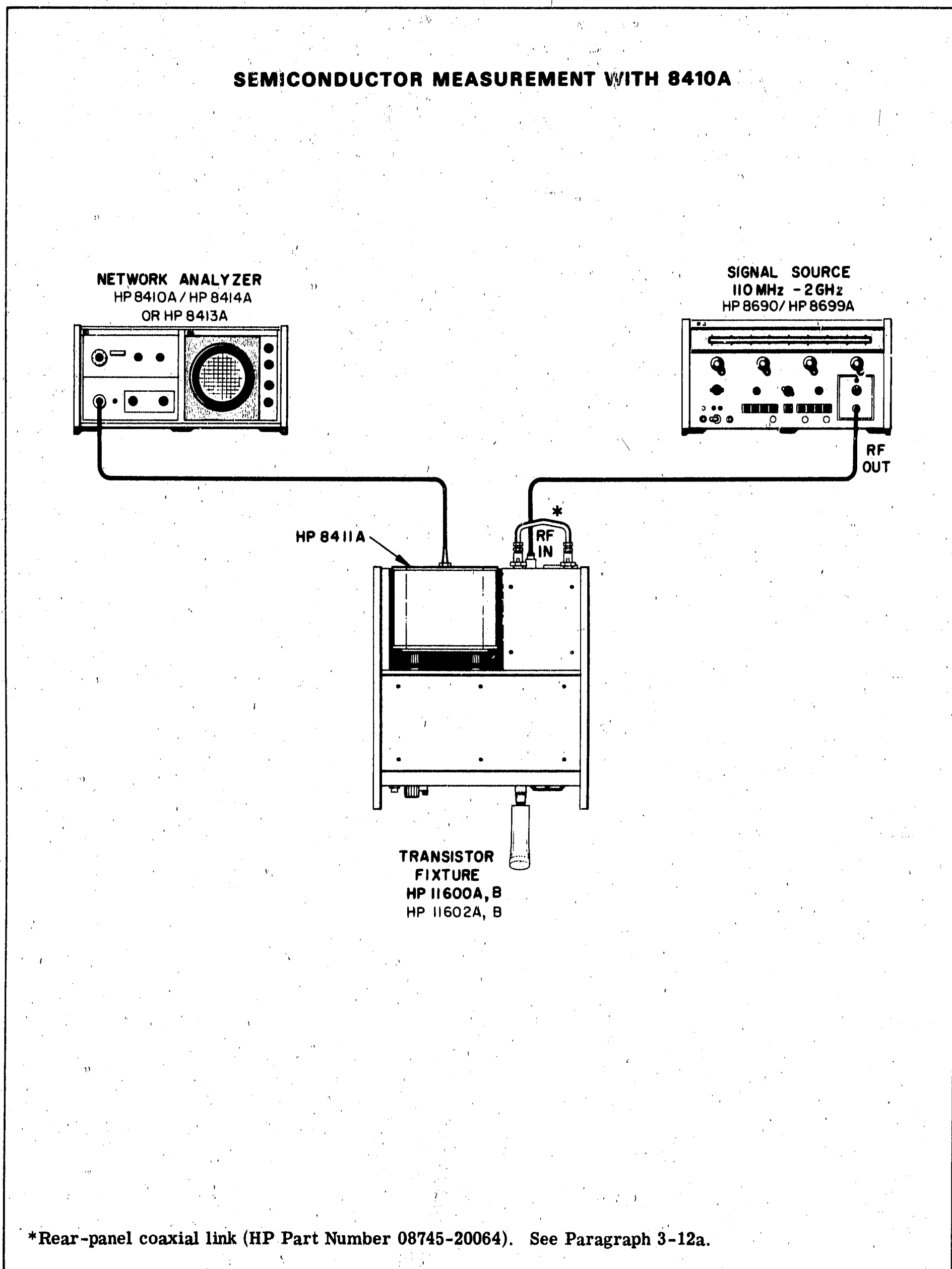

Figure 3-11. Semiconductor Measurement with 8410A Network Analyzer Readout (Sheet 1 of 2)

SEMICONDUCTOR MEASUREMENT WITH 8410A

CALIBRATION DESCRIPTION. Calibration consists of obtaining a reference indication using a termination of known magnitude and phase angle. Magnitude and phase reference indications for calibration are given in Table 3-2. An open circuit is obtained by not plugging anything into the transistor fixture. Calibrators, either a short, through section, or a 50-ohm load, may be used for a more accurate calibration. If a calibrator is used, see Figure 3-8 for proper positioning of fixture snap-on dial and calibrator. For normal calibration, only one s parameter with only one of the known terminations is needed. Calibration for greater accuracy is discussed in Paragraph 3-18.

CALIBRATION PROCEDURE. To calibrate the system containing a transistor fixture and 8410A Network Analyzer readout, perform the following:

1. Connect equipment as shown in setup opposite.
2. Set the signal source to sweep the band of interest.
3. Set the 8745A to look at the reflection coefficient of an open or a short and adjust the 8745A REFERENCE PLANE EXTENSION to cancel out the linear phase error (equal reference and test channel electrical lengths). For the 8414A, adjust for the smallest cluster. If an 8413A with an oscilloscope connected to its PHASE output is used, adjust for a horizontal line.

NOTE

For small signal measurements, adjust the signal source RF output for minimum signal level required to maintain a phase locked condition in the Network Analyzer.

4. Connect the calibrator to be used. (See Figure 3-8.)
5. If an 8414A is used as the readout, adjust the 8410A controls as follows:
 - a. Adjust the PHASE VERNIER for the reference phase indication of the calibrator selected (e.g., open circuit, press S_{11} or S_{22} , adjust for 0 degrees). See Table 3-2.
 - b. Adjust the TEST CHANNEL GAIN and AMPL VERNIER controls for a magnitude of one.

6. If an 8413A is used as the readout, set the signal source to CW and adjust the 8410A controls as follows:

- a. Adjust the PHASE VERNIER control for the reference phase indication of the termination selected (e.g., open circuit, press S_{11} or S_{22} , adjust for 0°). See Table 3-2.
- b. Adjust the TEST CHANNEL GAIN and AMPL VERNIER controls for a 0 dB indication. For S_{11} or S_{22} , the 8413A indicates return loss (0 dB return loss equals a reflection coefficient of 1). For S_{21} and S_{12} , the 8413A indicates gain or loss in dB.

SEMICONDUCTOR BIASING. The semiconductor under test must be biased for a given collector-emitter or drain-source voltage and a given collector or drain current. The two voltages required may be furnished either by the HP Model 8717A Transistor Bias Supply, or by a dual dc power supply. Instructions for connecting the bias supply to the 8745A and adjusting it to bias the unit under test are presented in Paragraph 3-13.

MEASUREMENT. To measure the s parameters of the semiconductor under test, perform the following:

1. Select INPUT PORT A or B as indicated on the transistor fixture.
2. Select the S PARAMETER to be measured.
3. If an 8414A plug-in is used in the 8410A Network Analyzer, read the magnitude and phase from the CRT.
4. If an 8413A is used in the 8410A the amplitude display is relative magnitude in dB of the incident and reflected (S_{11} , S_{22}) or incident and transmitted (S_{21} , S_{12}) signals. These can be converted to reflection $|\rho|$ or transmission $|\tau|$ coefficients with the following equations:

$$|\rho| = \frac{1}{\text{antilog } 0.05 \text{ (return loss in dB)}}$$

$$|\tau| = \text{antilog } 0.05 \text{ (gain in dB)}$$

$$|\tau| = \frac{1}{\text{antilog } 0.05 \text{ (loss in dB)}}$$

Figure 3-11. Semiconductor Measurement with 8410A Network Analyzer Readout (Sheet 2 of 2)

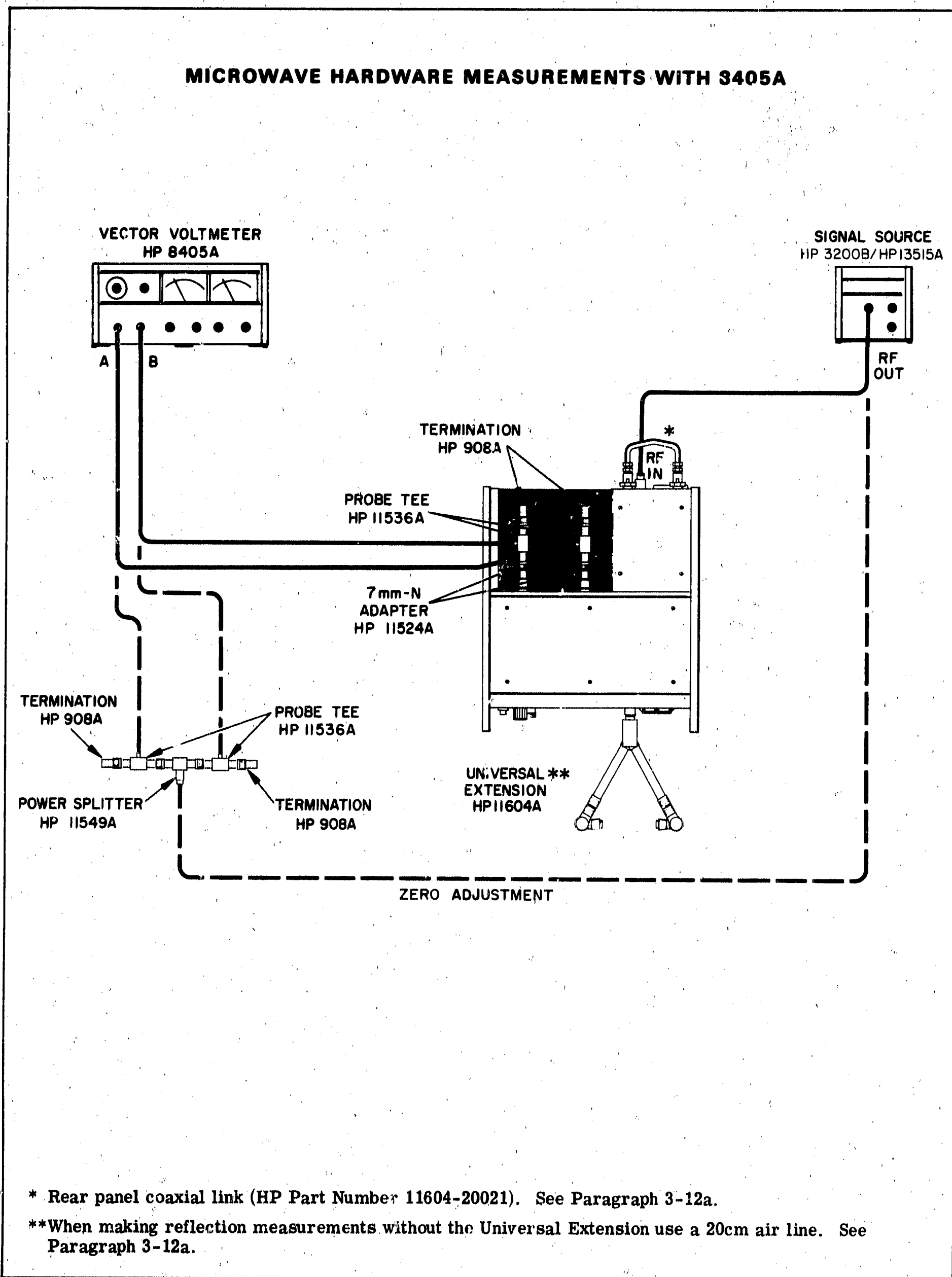

Figure 3-12. Microwave Hardware Measurements with 8405A Vector Voltmeter Readout (Sheet 1 of 2)

MICROWAVE HARDWARE MEASUREMENTS WITH 8405A

CALIBRATION DESCRIPTION. Calibration consists of obtaining a reference indication using a termination of known magnitude and phase angle. Magnitude and phase reference indications for calibration are given in Table 3-2. A through section is obtained by connecting the two 11604A Universal Extension arms together. For normal calibration, only one s parameter with only one of the known terminations is needed. Calibration for greater accuracy is discussed in Paragraph 3-18.

CALIBRATION PROCEDURE. To calibrate the system containing a Universal Extension and 8405A Vector Voltmeter readout, perform the following:

1. Connect equipment as shown in test setup opposite. If measurements are to be made at more than one frequency, make zero adjustment of the vector voltmeter before connecting the probe tee's to the 8745A as follows:
 - a. Connect the signal source to the input port of the Model 11549A Power Splitter.
 - b. Connect the probe tee's to the two output ports of the power splitter. Terminate probe tee's with 908A 50-ohm loads.
 - c. Adjust the 8405A PHASE METER OFFSET to zero, and adjust PHASE ZERO for zero phase-meter reading.
 - d. Disconnect the RF cable and probe tee's from the power splitter. Connect the RF cable to the 8745A RF INPUT. Connect the probe tee's to the 8745A, Channel A to the REFERENCE output and Channel B to the TEST output.
2. Set the 8405A to phase lock to the applied signal.
3. Establish the appropriate calibration condition, and select the appropriate input port and s parameter. The "appropriate" calibration condition for reflection measurements would be a short or open where the input port of the device under test is to be connected. For transmission measurements the "appropriate" condition would be a through connection.

4. Adjust the signal source RF output to obtain a convenient Channel B voltage reference on the 8405A.
5. Note Channel A magnitude.
6. Adjust the 8745A REFERENCE PLANE EXTENSION for the reference indication of the selected calibration condition (e.g., open circuit, press S_{11} or S_{22} , adjust for 0°). See Table 3-2.

The system is now calibrated for the frequency of the signal source. If measurements are to be made at more than one frequency, check for equal reference and test channel electrical lengths by changing the frequency of the signal source. If the electrical lengths are equal, the phase will not change with a change in frequency. To equalize the electrical lengths, adjust the 8405A PHASE ZERO to the appropriate phase reference indication at the lowest frequency, then adjust the 8745A REFERENCE PLANE EXTENSION for the same phase reference indication at the highest frequency of interest. Repeat these adjustments for minimum change in phase.

MEASUREMENT. To measure the s parameters of the microwave device under test, perform the following:

1. Insert the device to be tested between the arms of the Universal Extension and select INPUT PORT A or B as desired.
2. Select the S PARAMETER to be measured.
3. Adjust the signal source RF output to return the 8405A Channel A signal to the magnitude noted in step 5 of the calibration procedure.
4. Compute the s parameter magnitude from

$$\text{Magnitude} = \frac{\text{measured channel B voltage}}{\text{reference channel B voltage}}$$
5. Read the phase directly on the 8405A phase meter.

Figure 3-12. Microwave Hardware Measurements with 8405A Vector Voltmeter Readout (Sheet 2 of 2)

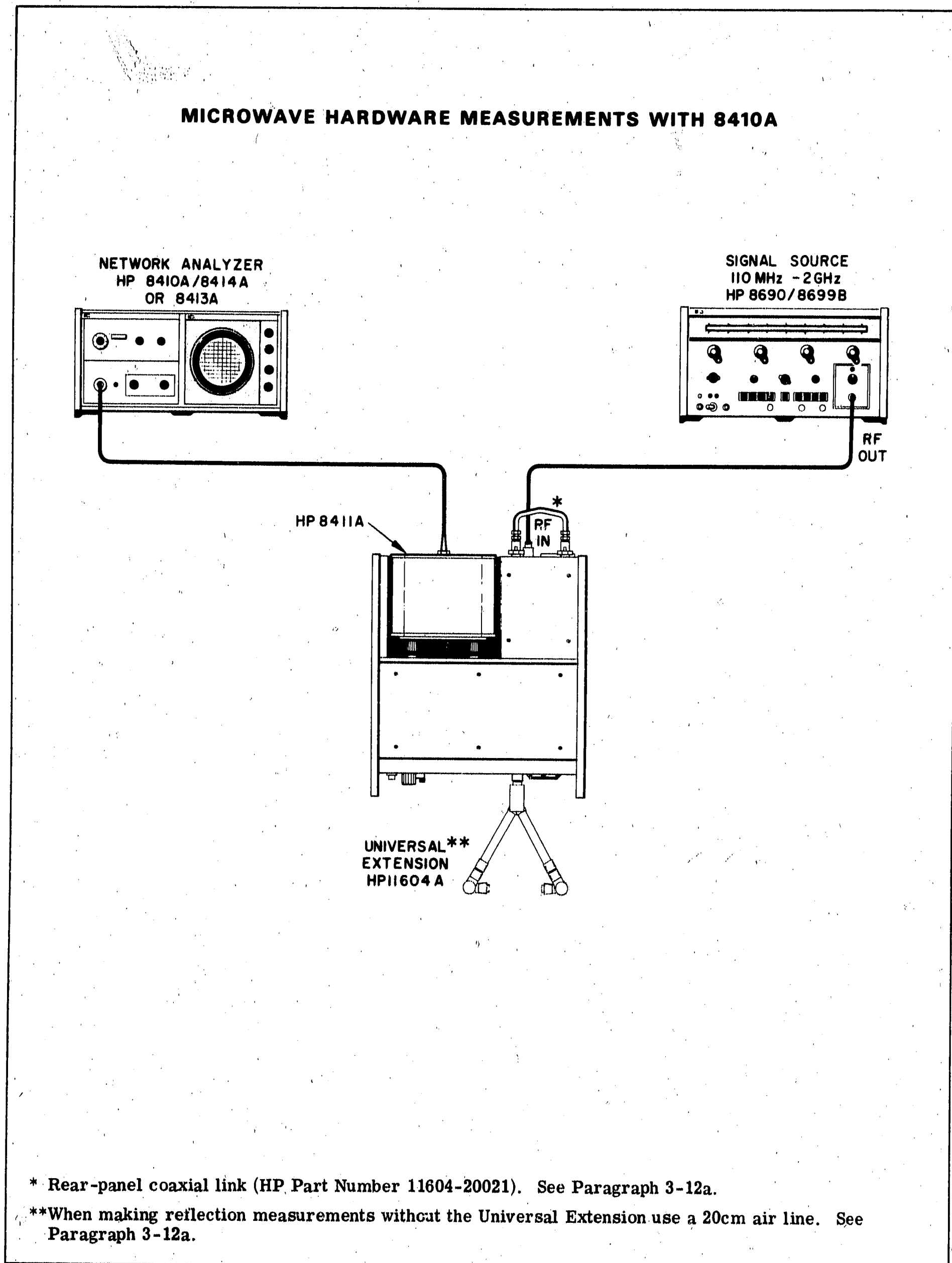

Figure 3-13. Microwave Hardware Measurement with 8410A Network Analyzer Readout (Sheet 1 of 2)

MICROWAVE HARDWARE MEASUREMENTS WITH 8410A

CALIBRATION DESCRIPTION. Calibration consists of obtaining a reference indication using a termination of known magnitude and phase angle. Magnitude and phase reference indications for calibration are given in Table 3-2. A through section is obtained by connecting the two 11604A Universal Extension arms together. For normal calibration, only one s parameter with only one of the known terminations is needed. Calibration for greater accuracy is discussed in Paragraph 3-18.

CALIBRATION PROCEDURE. To calibrate the system containing a Universal Extension and 8410A Network Analyzer readout, perform the following:

1. Connect equipment as shown in test setup opposite.
2. Set the signal source to sweep the band of interest.
3. Set the 8745A to look at a reflection coefficient of an open or a short and adjust the 8745A REFERENCE PLANE EXTENSION to cancel out the linear phase error (equal reference and test channel electrical lengths). For the 8414A, adjust for the smallest cluster. For an 8413A with an oscilloscope connected to its PHASE output, adjust for a horizontal line.
4. Connect the termination to be used (Table 3-2).
5. If an 8414A is used as the readout, adjust the Network Analyzer controls as follows:
 - a. Adjust the PHASE VERNIER for the reference phase indication of the termination selected (e.g., through section press S₂₁ or S₁₂, adjust for 0°).
 - b. Adjust the TEST CHANNEL GAIN and AMPL VERNIER controls for a magnitude of one.

6. If an 8413A is used as the readout, set the signal source to CW and adjust the 8410A controls as follows:

- a. Adjust the PHASE VERNIER control for the reference phase indication of the termination selected (e.g., through section press S₂₁ or S₁₂, adjust for 0°).
- b. Adjust the TEST CHANNEL GAIN and AMPL VERNIER controls for a zero dB indication. For S₁₁ and S₂₂ the 8413A indicates return loss (0 dB return loss equals a reflection coefficient of 1). For S₂₁ and S₁₂ the 8413A indicates gain or loss in dB.

MEASUREMENT. To measure the s parameters of the microwave device under test, perform the following:

1. Insert the device to be tested between the arms of the Universal Extension and select INPUT PORT A or B as desired.
2. Select the S PARAMETER to be measured.
3. If an 8414A plug-in is used in the 8410A Network Analyzer, read the magnitude and phase from the CRT.
4. If an 8413A is used in the 8410A the amplitude display is relative magnitude in dB of the incident and reflected (S₁₁, S₂₂) or incident and transmitted (S₂₁, S₁₂) signals. These can be converted to reflection $|\rho|$ or transmission $|\tau|$ coefficients with the following equations:

$$|\rho| = \frac{1}{\text{antilog } 0.05 \text{ (return loss in dB)}}$$

$$|\tau| = \text{antilog } 0.05 \text{ (gain in dB)}$$

$$|\tau| = \frac{1}{\text{antilog } 0.05 \text{ (loss in dB)}}$$

Figure 3-13. Microwave Hardware Measurement with 8410A Network Analyzer Readout (Sheet 2 of 2)

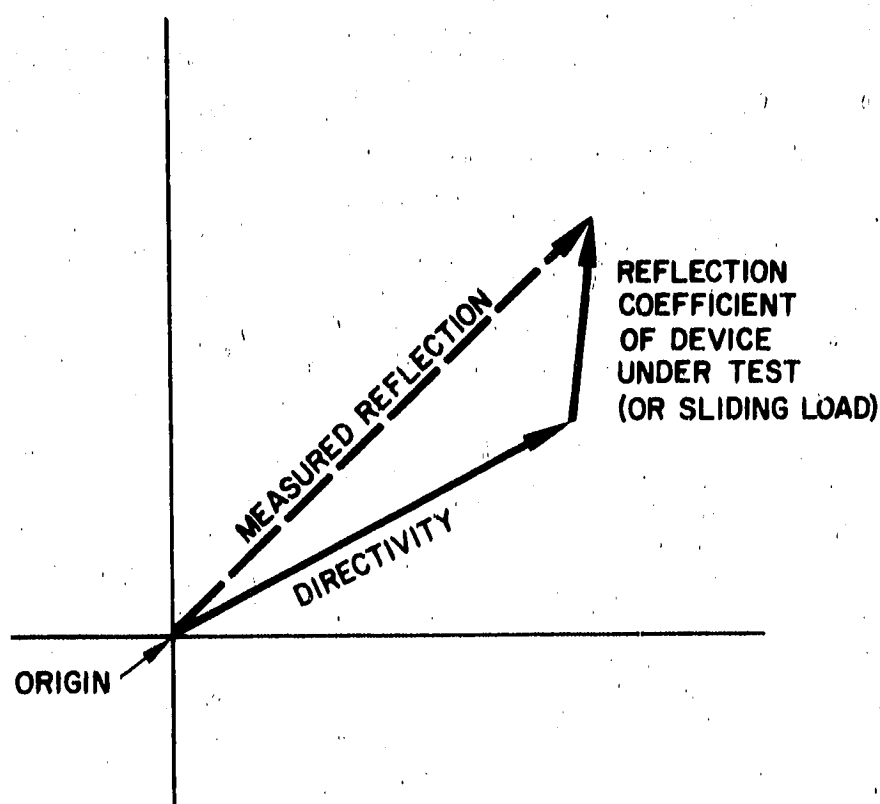

Figure 3-14. Typical Polar Plot Showing Measured Reflection as the Sum of Directivity and Load Vectors

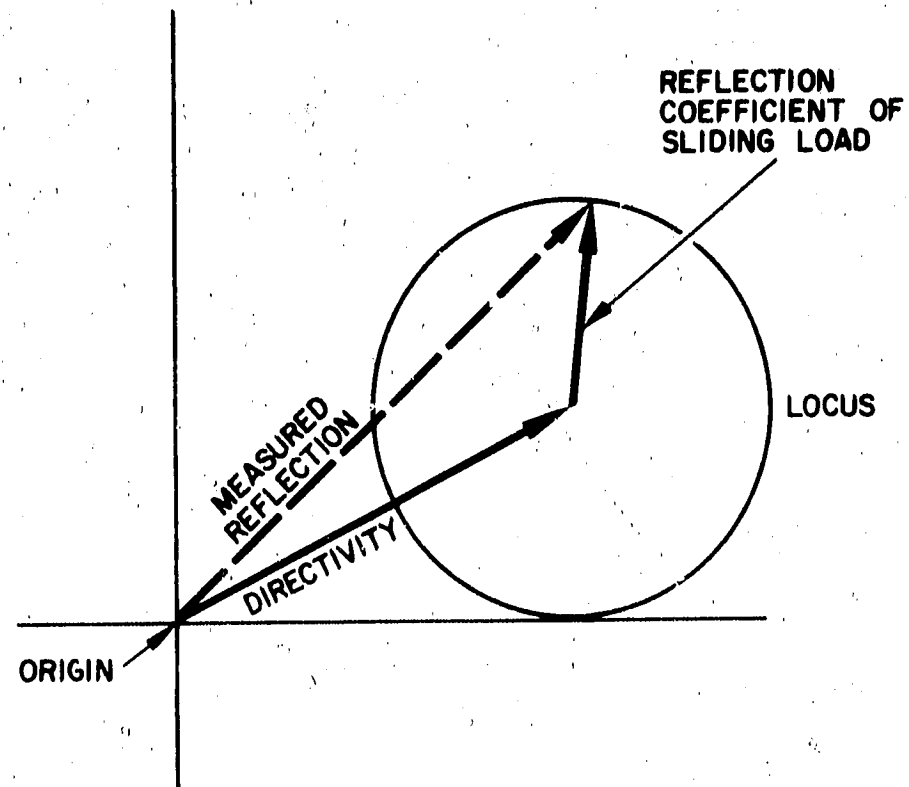

Figure 3-15. Typical Polar Plot Showing Locus of Measured Reflection when Sliding Load is Moved

3-18. INCREASED ACCURACY BY MINIMIZING DIRECTIVITY ERRORS.

3-19. Greatest accuracy for single-frequency, high-resolution reflection measurements can be obtained by connecting the device under test directly to the front-panel ports of the 8745A. If it is necessary to make connections through an 11604A, air line, or coaxial cable, any movement of the 11604A swivel joints or flexing of coaxial cable will alter the phase relations of the reflections in the test setup; therefore, any component inserted between the 8745A and the device under test should remain in the same position for both calibration and measurements.

3-20. Directivity errors are not significant unless small reflection coefficients are being measured. This error can be cancelled at single frequencies when necessary. The measured reflection is the vector sum of the directivity vector plus the reflection coefficient of the device under test (Figure 3-14). The error can be calibrated out by using a sliding load. Figure 3-15 depicts the sliding load in one position at a given frequency. As the sliding load is moved, the magnitude of its reflection coefficient remains constant but the phase of the coefficient changes. As the load is moved its reflection coefficient indication rotates in a circle of constant magnitude about the directivity vector. The center of this circle is the tip of the directivity vector. When the location of the center of the circle is known, the error can be vectorially subtracted from the measured reflection to obtain the reflection coefficient of the device under test.

3-21. On the 8414A polar display, the vector subtraction can be performed directly with the horizontal and vertical position controls. Increase the 8410A test

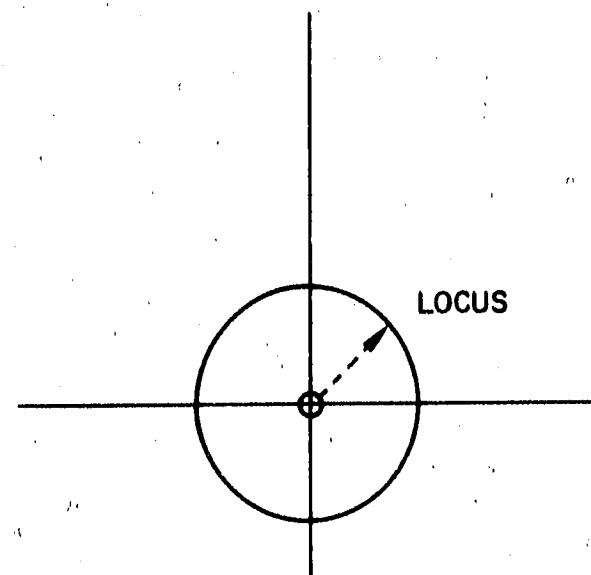

Figure 3-16. Polar Display Showing Locus of Sliding Load Vector with Directivity Cancelled

channel gain so full-scale reflection on the polar display is suitable for the component you wish to measure and perform the following:

a. For single frequencies above 1GHz, setup the 8745A to measure the desired reflection coefficient (S_{11} or S_{22}). Calibrate the display unit and attach the sliding load (HP Model 907A) to the 8745A incident power port (INPUT PORT A or B). Slide the load and adjust the horizontal and vertical controls until the circle rotates about the center of the CRT, as shown in Figure 3-16. Directivity is now cancelled for this frequency and this test channel gain on the Network Analyzer.

b. For single frequencies below 1 GHz, setup the 8745A to measure the desired reflection coefficient (S_{11} or S_{22}). Calibrate the display unit and connect a low reflection termination ($|\rho| = 0.005$ max.), such

as a HP Model H01-909A, to the 8745A incident power port (INPUT PORT A or B) at the reference plane. Since the magnitude of the Model H01-909A reflection is very small, the measured reflection coefficient can be considered the directivity vector. Adjust the 8414A horizontal and vertical controls to place the dot in the center of the CRT. Directivity is now cancelled for this frequency and this test channel gain on the Network Analyzer.

3-22. With either the 8413A or 8405A, the vector subtraction must be done manually:

a. For single frequencies above 1GHz, setup the 8745A to measure the desired reflection coefficient (S_{11} or S_{22}). Calibrate the display unit and attach a sliding load (HP Model 907A) to the 8745A incident power port (INPUT PORT A or B). Slide the load to find the maximum magnitude* of reflection coefficient, $|\rho_1|$. Record $|\rho_1|$ and its phase angle. Slide the load to find the minimum magnitude** of reflection coefficient, $|\rho_2|$. Record $|\rho_2|$ and its phase angle. If the directivity vector is larger than the load reflection, the measured phase angle of $|\rho_1|$ and $|\rho_2|$ will be the same, as shown in Figure 3-17, and the magnitude of the directivity vector can be determined from:

$$\frac{|\rho_1| + |\rho_2|}{2}$$

If the directivity vector is smaller than the load reflection, the phase angle of $|\rho_2|$ will be 180° from the phase angle of $|\rho_1|$ as shown in Figure 3-18, and the magnitude of the directivity vector can be determined from:

$$\frac{|\rho_1| - |\rho_2|}{2}$$

Record the magnitude and phase of the directivity vector. The phase is the phase angle of $|\rho_1|$. The directivity vector must be vectorially subtracted from any reflection measurement at this frequency (see step c).

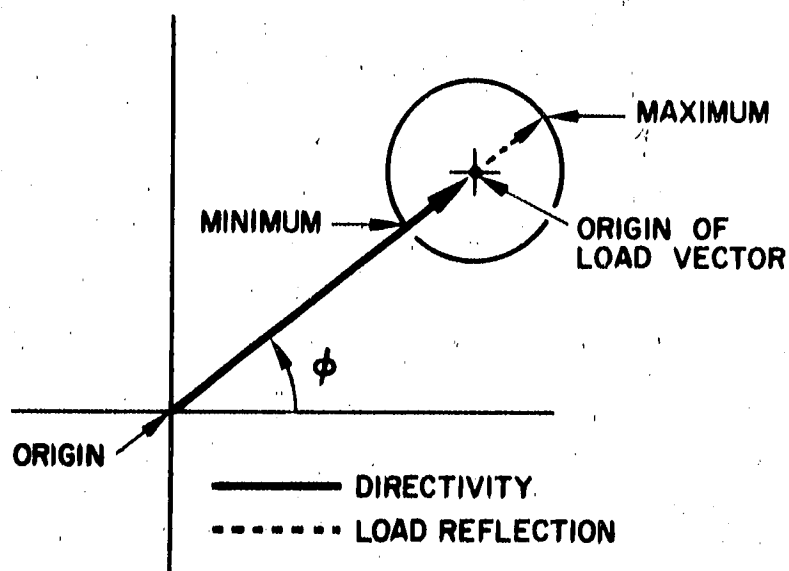

Figure 3-17. Typical Polar Plot Showing Method of Separating Load Vector from Directivity Vector when Directivity Vector is Larger than Load Vector

* Maximum magnitude: directivity vector plus reflection from sliding load adding in phase.

**Minimum magnitude: reflection from sliding load 180° from directivity vector.

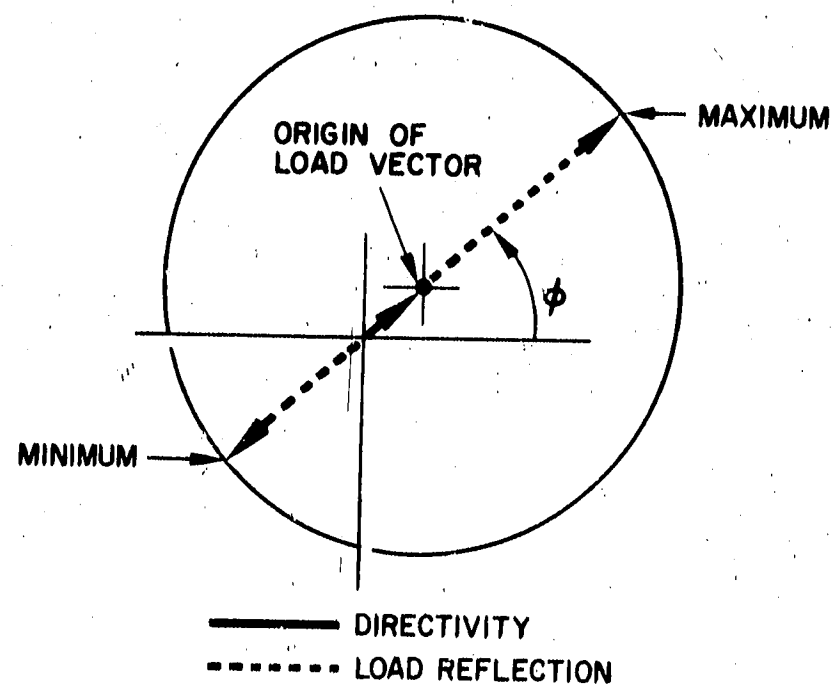

Figure 3-18. Typical Polar Plot Showing Method of Separating Load Vector from Directivity Vector when Directivity Vector is Smaller than Load Vector

b. For single frequencies below 1GHz, setup the 8745A to measure the desired reflection coefficient (S_{11} or S_{22}). Calibrate the display unit and connect a low reflection termination ($|\rho| = 0.005$ max.), such as a HP Model H01-909A, to the 8745A incident power port (INPUT PORT A or B). Since the magnitude of the Model H01-909A reflection is very small, the measured reflection coefficient can be considered the directivity vector. Record the phase and magnitude of the directivity vector. This vector must be subtracted from any reflection measurement at this frequency (see step c below).

c. The vector subtraction can be accomplished conveniently by performing the subtraction graphically (using reflection coefficient, not dB) as shown in Figure 3-19. Plot the directivity vector and the measured reflection vector on polar graph paper. Place a second sheet of polar graph paper over the first with the origin of the second graph at the tip of the directivity vector, and with the vertical and horizontal axes parallel to the vertical and horizontal axes of the first graph. Draw a vector from the origin (tip of the directivity vector) to the tip of the measured vector. This vector is the reflection coefficient of the device under test.

3-23. CALIBRATING OUT THE REFLECTION OF THE TRANSISTOR FIXTURE.

3-24. The reflection of the transistor fixture is significant when the reflection of the device under test is very small. The error can be calibrated out at single frequencies. Figure 3-20 shows how the fixture reflection can add vectorially to the transistor reflection. Measure the fixture reflection at a single frequency by plugging the 50-ohm termination into the fixture and measure S_{11} and S_{22} . Make sure the input

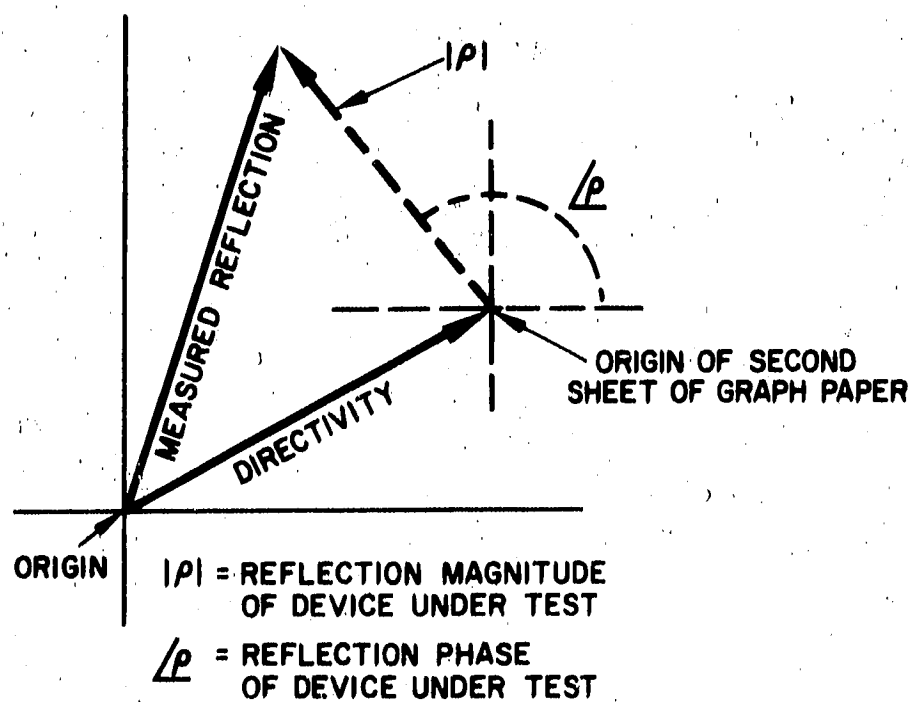

Figure 3-19. Typical Polar Plot Showing Graph Method of Cancelling Directivity

port of the 8745A is the one that will be used for the transistor measurement. Since the magnitude of the 50-ohm termination's reflection is very small, the measured reflection coefficient can be considered the fixture reflection plus the directivity vector.

3-25. When using the Network Analyzer with a polar display, the vector subtraction can be performed directly with the horizontal and vertical position controls on the display. Adjust these controls until the dot representing the measured reflection is at the center of the display. Fixture reflection is now eliminated at this frequency and for this 8410A gain setting. When using the Network Analyzer with a 8413A display unit, or the 8405A, the vector subtraction can be performed (using reflection coefficient, not dB), as in paragraph 3-22c, by inserting fixture plus directivity for directivity.

3-26. REMOTE S-PARAMETER SELECTION.

3-27. A thirty-six pin connector on the rear panel of the 8745A provides contacts for remote s parameter selection and biasing. Eleven of the thirty-six pins are used in the 8745A. The pins and their uses are given in Table 3-1. The pins used for remote selection are:

Pin	Function
17	Remote Select
6	Remote S Parameter Select.
24	Remote S Parameter Select.
18 and 36	Remote Control Common

3-20

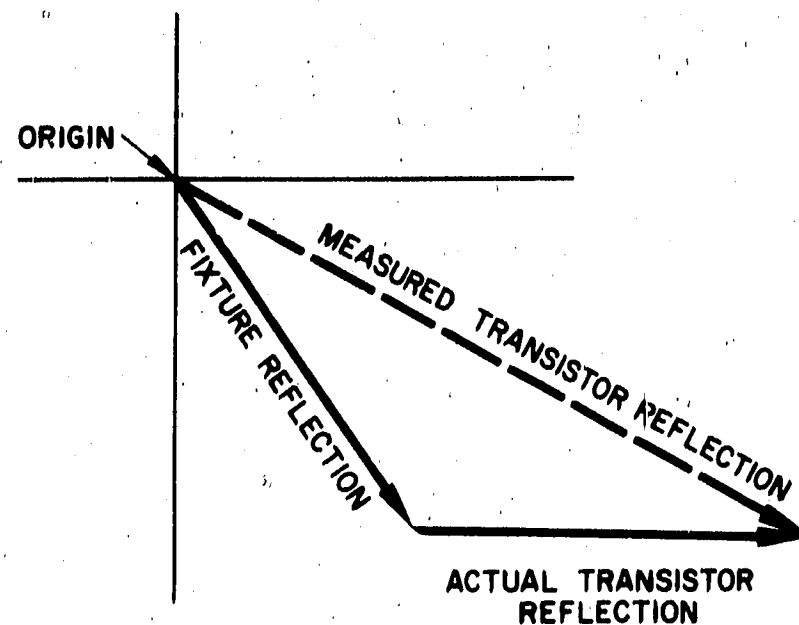

Figure 3-20. Typical Polar Plot Showing Measured Transistor Reflection as the Sum of Fixture and Transistor Reflections

3-28. When remote select pin 17 is open or not connected to a remote control common (pins 18 or 36), the 8745A is in the manual mode. In this mode of operation the front panel push-buttons are all enabled and s parameter select pins 6 and 24 are disabled. Parameters can be selected from the front panel only, and either port A or port B can be selected as the input port to the device under test.

3-29. When remote select pin 17 is connected to a remote control common (pins 18 or 36), the 8745A is in the remote mode. In this mode of operation the front-panel pushbuttons are disabled and remote s parameter select inputs pins 6 and 24 are enabled, allowing s parameter selection through only the remote input lines.

3-30. When the 8745A is set to the remote mode, port A is always defined as the input port to the device under test. Since the four s parameters are defined as: S_{11} = input reflection coefficient, S_{21} = forward transmission coefficient, S_{12} = reverse transmission coefficient and S_{22} = output reflection coefficient, the input port of the device under test must be clearly defined. When a transistor fixture is being used with a 8745A, the snap-on dial may indicate that port B is to be selected; however, in remote operation port B cannot be selected. Nevertheless, results equivalent to selecting port B can be obtained. As indicated in Figures 3-3 and 3-4, selecting port A and S_{11} is equivalent to selecting port B and S_{22} ; therefore, to measure S_{11} remotely when port B is connected to the input port of the device under test, remotely select S_{22} .

3-31. The contact closures required for remote selection of s parameters are listed in Table 3-3. Shorting pin 17 to either of the remote control returns, pin 18 or pin 36, selects remote programming. To select S_{11} , for example, pins 6 and 24 must be open with respect to both of the remote control returns.

3-32. A typical contact closure circuit is shown in Figure 3-21. The 8745A supplies approximately +12 Vdc when the contact is open and 12 mA of current flows when the contact is closed. Noise on the remote control lines should not exceed 3 volts peak-to-peak in the open circuit condition and 1.8 volts peak-to-peak in the closed circuit condition.

3-33. CARE OF APC-7 CONNECTORS.

3-34. RF connections to and from the device under test and to the phase-amplitude ratio indicator are made with APC-7 style, 50-ohm, 7-mm sexless connectors. These connectors should be handled with particular care for two reasons:

a. Continuity through APC-7 connectors is obtained by end-to-end contact of the inner and outer conductors. Consequently, the electrical performance of the connector is largely dependent upon the condition of these exposed surfaces.

b. The inner conductors of the front-panel connectors are attached to directional coupler striplines, and any rotational force on the inner conductor may result in damage to the directional coupler.

3-35. Important recommendations about the handling and care of the APC-7 connectors are given in Figure 3-22. The part of an input connector that is most likely to be damaged is the inner conductor contact. Since it protrudes slightly beyond the plane

of electrical contact, any wiping action of one connector across the other can damage the contact enough to cause a discontinuity. The risk of this kind of damage can be minimized, as stated in Figure 3-22, by always having the coupling sleeves on the input port connectors fully extended.

3-36. CONTACT REPLACEMENT.

3-37. Replacement inner conductor contacts are available from Hewlett-Packard (Part Number 1250-0907), and from Amphenol RF Division, Danbury, Connecticut (Part Number 131-129).

3-38. The important precautions that apply to the replacement of inner conductor contacts are these:

- a. Do not disassemble the connector.
- b. Do not apply more than slight inward pressure to the inner conductor.
- c. Do not apply ANY twisting force to the inner conductor.
- d. Do not attempt to repair contacts.
- e. Do not re-use contacts.

CAUTION

Inward pressure or twisting force applied to the inner conductor can render the Model 8745A inoperative.

Table 3-3. Signal Requirements for Remote S-Parameter Selection

Parameter to be measured	Input connected to PORT A			Input connected to PORT B		
	Pin 18 or 36 to:		Lamps Lit	Pin 18 or 36 to:		Lamps Lit
	Pin 24	Pin 6		Pin 24	Pin 6	
S ₁₁	Open	Open	A, S ₁₁	Shorted	Shorted	A, S ₂₂
S ₁₂	Open	Shorted	A, S ₁₂	Shorted	Open	A, S ₂₁
S ₂₁	Shorted	Open	A, S ₂₁	Open	Shorted	A, S ₁₂
S ₂₂	Shorted	Shorted	A, S ₂₂	Open	Open	A, S ₁₁

Before selecting parameters, setup for remote control by shorting pin 17 to either pin 18 or 36.
NOTE: There are two requirements for selecting each parameter.

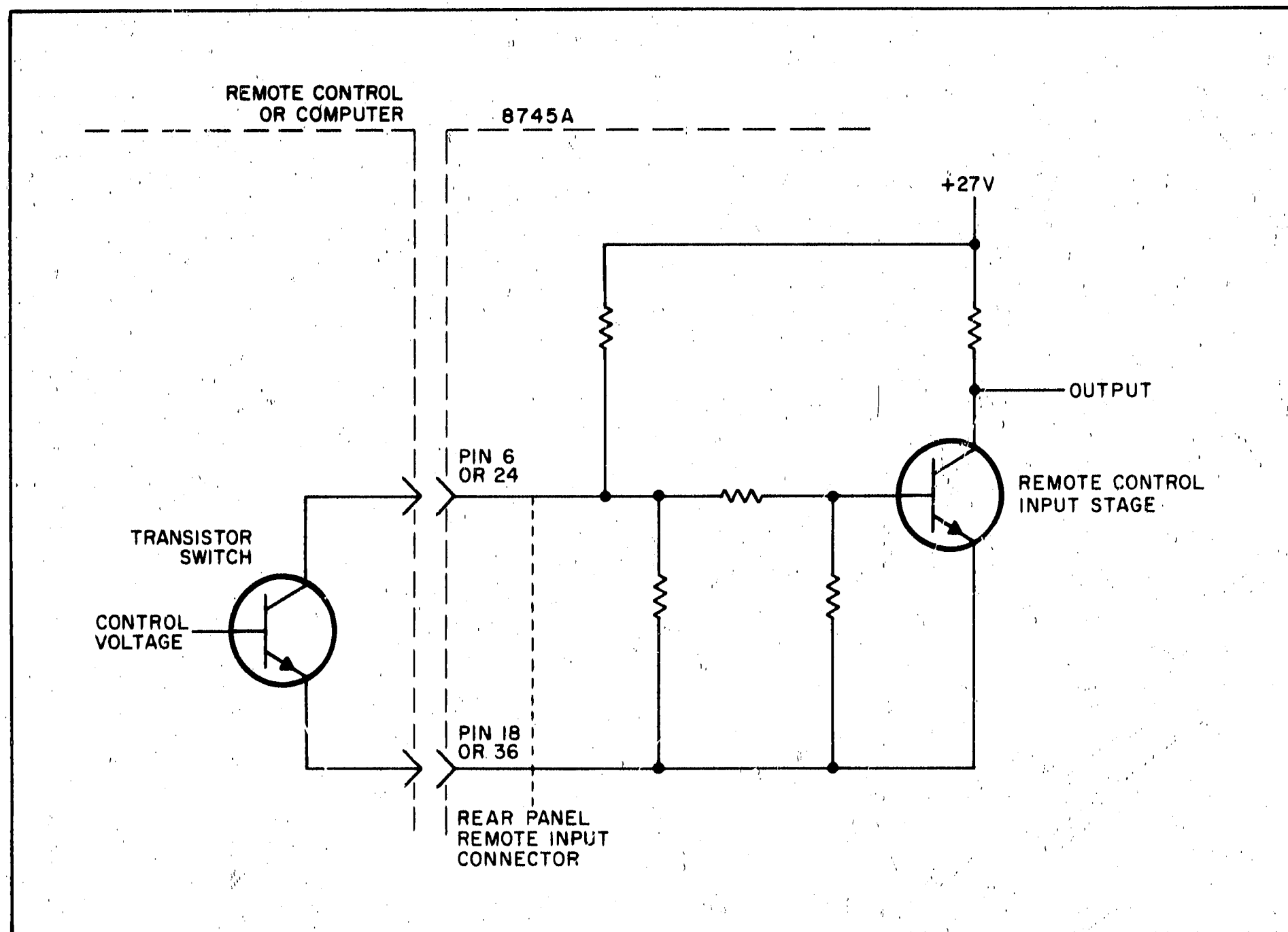

Figure 3-21. Typical Remote Contact Closure Circuit

3-39. Because of the above considerations, contact removal should not be attempted with ordinary hand tools. Only the Hewlett-Packard self-positioning, hypodermic-action, contact extractor tool (Part Number 5060-0236)* should be used. This tool exerts no appreciable inward pressure and no twisting force on the inner conductor. Instructions for removing contacts are supplied with the tool.

3-40. No tool is required for installing a replacement contact. Insert the contact gently by hand, applying only enough inward pressure to snap it into place. Then check for proper installation by inspecting the contact for even spacing of its four segments. Also, test for normal spring action by applying light inward

pressure against the end of the contact with a pencil eraser. As the pressure is released the contact's spring action should cause it to move outward. If not, the contact is defective and should be replaced.

3-41. COUPLING MECHANISMS.

3-42. The coupling mechanism includes the coupling nut and the two-piece coupling sleeve assembly shown in Figure 3-22. Both of these parts can be replaced using procedures in Paragraph 4-33.

3-43. POWER SWITCH LAMP REPLACEMENT.

3-44. The lamp that indicates line power is applied to the Model 8745A is housed in the POWER switch pushbutton. To replace the lamp, unscrew the retaining ring near the front panel, pull out the pushbutton, and remove the lamp. Replacement lamp is HP Part Number 2140-0052, LAMP:GLOW.

* Part of APC-7 Connector Tool Kit HP 11591A.

APC-7 CONNECTORS

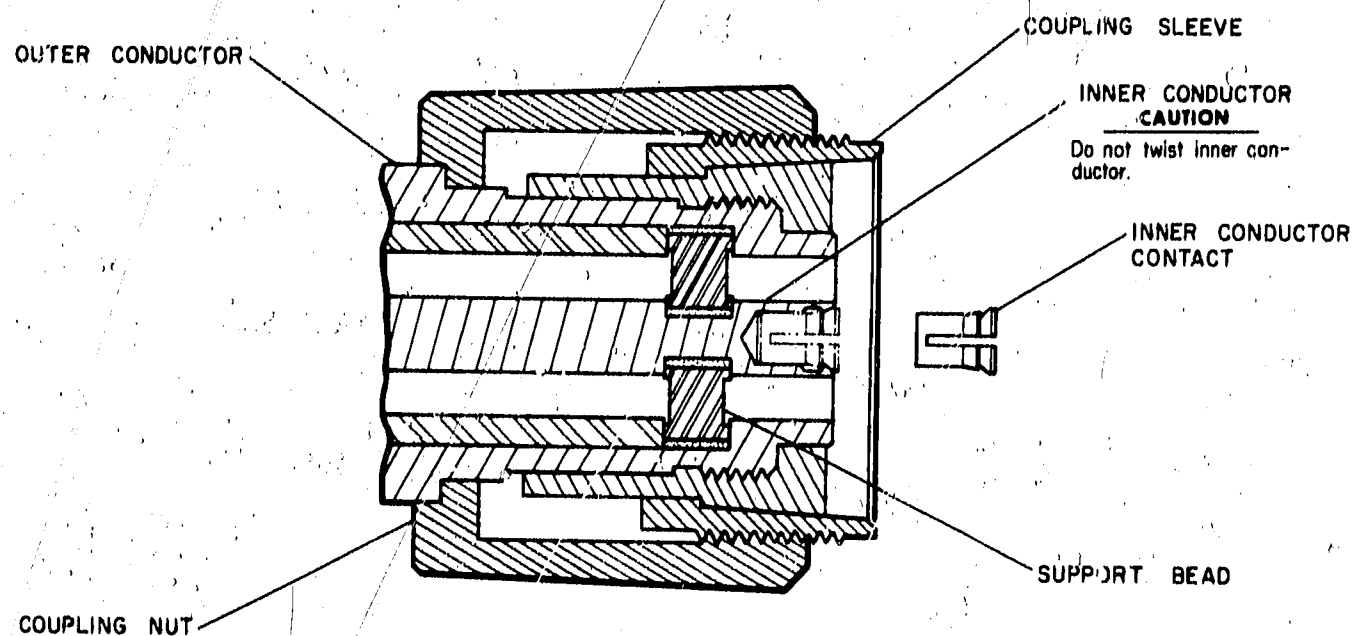

USE

To Connect:

1. On one connector, retract the coupling sleeve by turning the coupling nut counterclockwise until the sleeve and nut disengage.
2. On the other connector, fully extend the coupling sleeve by turning the coupling nut clockwise. To engage coupling sleeve and coupling nut when the sleeve is fully retracted, press back lightly on the nut while turning it clockwise.
3. Push the connectors firmly together, and thread the coupling nut of the connector with retracted sleeve over the extended sleeve. Leave the other coupling nut in the original position: closing the gap between coupling nuts tends to loosen the electrical connection.

To Disconnect:

1. Loosen the coupling nut of the connector showing the wider gold band.

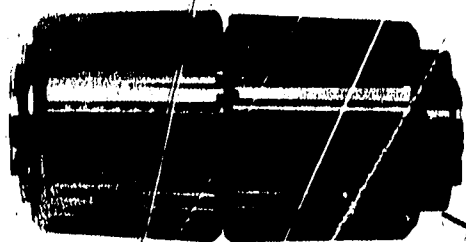

WIDER BAND

2. **IMPORTANT:** Part the connectors carefully to prevent striking the inner conductor contact.

CARE

1. Keep contacting surfaces smooth and clean. Irregularities and foreign particles can degrade electrical performance.

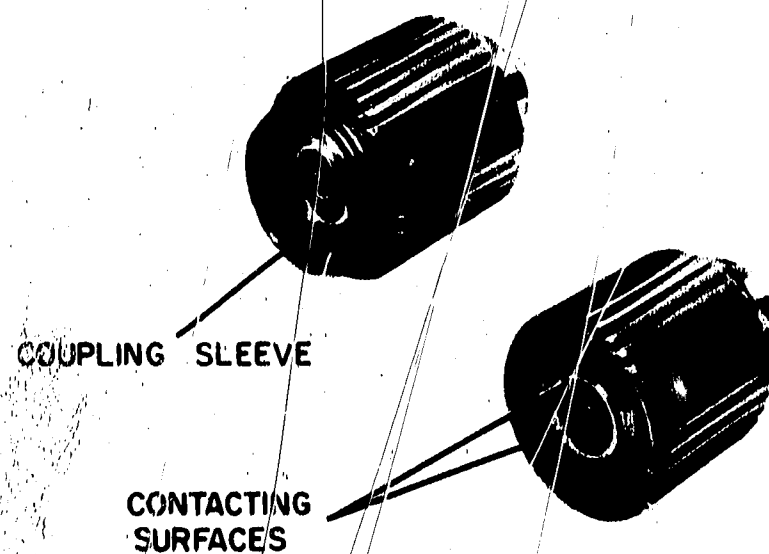

2. Protect the contacting surfaces when the connector is not in use by leaving the coupling sleeve extended.
3. Use lintless material and/or firm-bristled brush such as toothbrush for cleaning. If a cleaning fluid is needed use isopropyl alcohol. **IMPORTANT:** Do not use aromatic or chlorinated hydrocarbons, esters, ethers, terpenes, higher alcohols, ketones, or ether-alcohols such as benzene, toluene, turpentine, dioxane, gasoline, cellosolve acetate, or carbon tetrachloride. Keep exposure of the connector parts to both the cleaning fluid and its vapors as brief as possible.

Figure 3-22. APC-7 Connectors

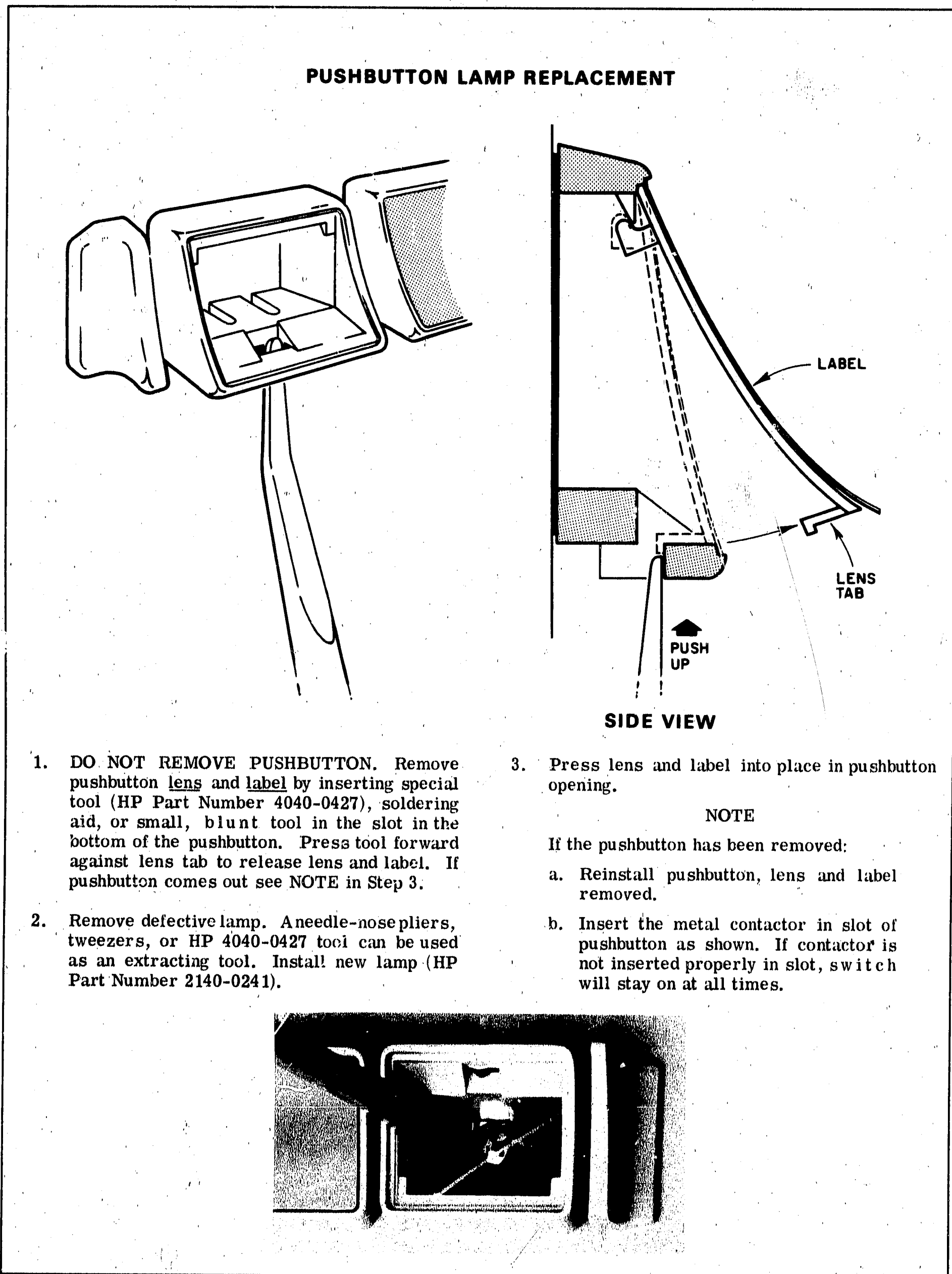

Figure 3-23. Pushbutton Lamp Replacement

MAINTENANCE

SECTION IV MAINTENANCE

4-1. INTRODUCTION.

4-2. This section provides instructions for performance testing, troubleshooting, and repairing the 8745A. If the serial prefix (the first three numbers of the serial number) of your instrument is different than that listed on the title page of this manual, then there are differences between your instrument and the instrument described in this manual. See Paragraph 1-35.

4-3. PERFORMANCE TESTING.

4-4. PROCEDURES.

4-5. The procedures in Figure 4-2 check the 8745A performance for incoming inspection, periodic evaluation, and troubleshooting. The tests can be performed without access to the instrument interior. The specifications of Table 1-1 are the performance standards.

4-6. TEST EQUIPMENT REQUIRED.

4-7. The test instruments and accessories required to make the performance checks are listed in Table 4-4. Test instruments other than the ones listed can be used provided their performance equals or exceeds the Critical Specifications listed.

4-8. ADJUSTMENTS.

4-9. The only adjustment is the digital counter friction clutch. The adjustment procedure is given in Figure 4-8.

4-10. TROUBLESHOOTING.

4-11. TEST EQUIPMENT REQUIRED.

4-12. The test instruments and accessories required for troubleshooting are listed in Table 4-4. Test instruments other than those listed can be used provided their performance equals or exceeds the Critical Specifications listed.

4-13. PROCEDURES.

4-14. Always start locating trouble with a thorough visual inspection for burned-out or loose components, loose connections, or any conditions which suggest a source of trouble. Check the fuse to see that it is not open.

4-15. If trouble cannot be isolated to a bad component by visual inspection, the trouble should be isolated to a circuit section. Isolation to a circuit section can be accomplished by using the troubleshooting procedures in Figures 4-4 through 4-7. Figure 4-4 is a general troubleshooting procedure and is also useful as a quick operational check.

This procedure isolates trouble to either the RF section or relay switching circuits and should be performed first.

4-16. The test point voltages presented in Tables 6-1, 6-2, and 6-3 are also useful in troubleshooting. The power supply voltages of the instruments used to take the voltages in the tables were close to 28 V. Therefore, if the power supply voltage of your instrument is other than 28 V the test point voltages will vary proportionally from those given in the tables.

4-17. TRANSISTOR TESTING.

4-18. IN-CIRCUIT TESTING. The common causes of transistor failures are internal short - and open-circuits. In transistor circuit testing the most important consideration is the transistor base-emitter junction. Like the control grid of a vacuum tube, this is the operational control point in the transistor. This junction is essentially a solid-state diode. For the transistor to conduct, the diode must conduct; that is, the diode must be forward biased. As with simple diodes, the forward-bias polarity is determined by the materials forming the junction. Use the transistor symbol on the schematic diagram to determine the bias polarity required to forward-bias the base-emitter junction. Figure 4-1 shows transistor symbols with terminals labeled. Notice that the emitter arrow points toward the type N material. The other two columns of the illustration compare the biasing required to cause conduction and cut-off. If the transistor base-emitter diode (junction) is forward-biased the transistor conducts. If the diode is heavily forward-biased, the transistor saturates. However, if the base-emitter diode is reverse-biased the transistor is cut off (open).

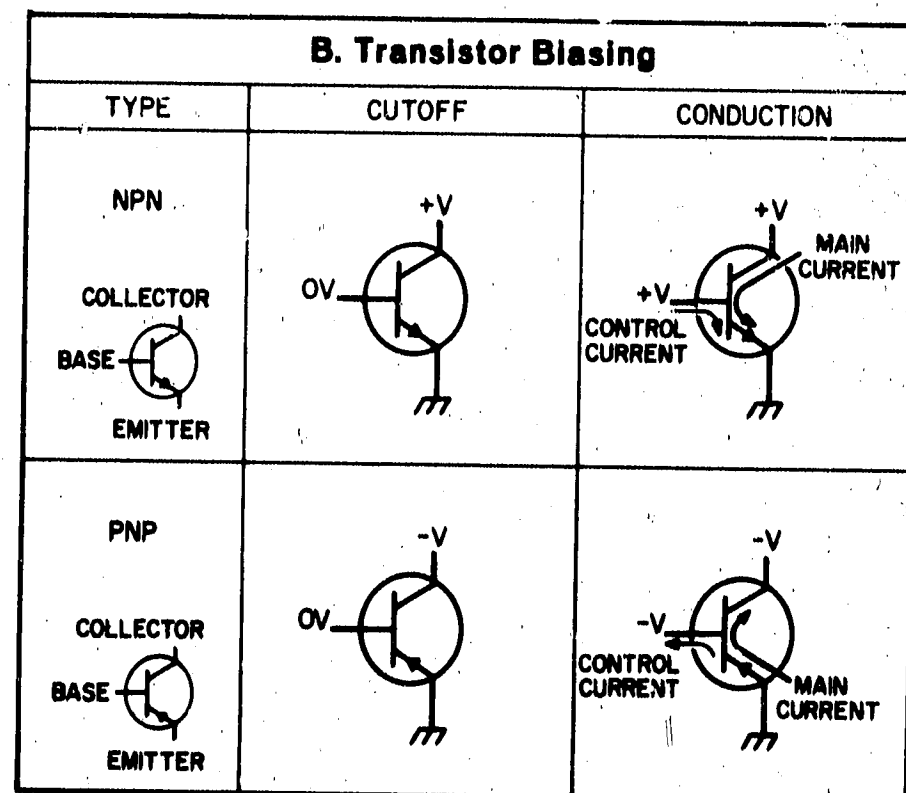

Figure 4-1. Transistor Biasing Characteristics

The voltage drop across a forward-biased emitter-base diode varies with transistor collector current. For example, a germanium transistor has a typical forward-bias, base-emitter voltage of 0.2-0.3 volt when collector current is 1-10 mA, and 0.4-0.5 volt when collector current is 10-100 mA. In contrast, forward-bias voltage for silicon transistors is about twice that for germanium types: about 0.5-0.6 volt when collector current is low, and about 0.8-0.9 volt when collector current is high.

4-19. When examining a transistor stage, first determine if the emitter-base diode is biased for conduction (forward-biased) by measuring the voltage difference between emitter and base. When using an electronic voltmeter, do not measure directly between emitter and base: there may be sufficient loop current between the voltmeter leads to damage the transistor. Instead, measure each voltage separately with respect to a power supply common point (not chassis). If the emitter-base diode is forward-biased, check for amplifier action by short-circuiting base to emitter while observing collector voltage. The short circuit eliminates base-emitter bias and should cause the transistor to stop conducting (cut off).

Collector voltage should then shift to near the supply voltage. Any difference is due to leakage current through the transistor and, in general, the smaller this current, the better the transistor. If collector voltage does not change the transistor has either an emitter-collector short circuit or emitter-base open circuit.

4-20. OUT-OF-CIRCUIT TESTING. The two common causes of transistor failure are internal short- and open-circuits. Remove the transistor from the circuit and use an ohmmeter to measure internal resistance. See Table 4-1 for measurement data.

CAUTION

Most ohmmeters can supply enough current or voltage to damage a transistor. Before using an ohmmeter to measure transistor forward or reverse resistance, check its open-circuit voltage and short-circuit current output **ON THE RANGE TO BE USED**. Open-circuit voltage must not exceed 1.5 volts and short-circuit current must be less than 3 mA. See Table 4-2 for safe resistance ranges for some common ohmmeters.

Table 4-1. Out-of-Circuit Transistor Resistance Measurements

Transistor Type		Connect Ohmmeter		Measure Resistance (ohms)
		Pos. lead to	Neg. lead to	
PNP Germanium	Small Signal	emitter	base*	200-250
		emitter	collector	10K-100K
	Power	emitter	base*	30-50
		emitter	collector	several hundred
PNP Silicon	Small Signal	emitter	base*	10K-100K
		emitter	collector	very high (might read open)
NPN Silicon	Small Signal	base	emitter	1K-3K
		collector	emitter	very high (might read open)
	Power	base	emitter	200-1000
		collector	emitter	high, often greater than 1M

*To test for transistor action, add collector-base short. Measured resistance should decrease.

Table 4-2. Safe Ohmmeter Resistance Ranges for Transistor Measurements

Ohm-meter	Range(s)	Open Circuit Voltage	Short Circuit Current	Lead	
				Color	Polarity
HP 412A HP 427A	Rx 1K Rx 10K Rx 100K Rx 1M Rx 10M	1.0V 1.0V 1.0V 1.0V 1.0V	1 mA 100 μ A 10 μ A 1 μ A 0.1 μ A	Red Black	+ -
HP 410C	Rx 1K Rx 10K Rx 100K Rx 1M Rx 10M	1.3V 1.3V 1.3V 1.3V 1.3V	0.57 mA 57 μ A 5.7 μ A 0.5 μ A 0.05 μ A	Red Black	+ -
HP 410B	Rx 100 Rx 1K Rx 10K Rx 100K Rx 1M	1.1V 1.1V 1.1V 1.1V 1.1V	1.1 mA 110 μ A 11 μ A 1.1 μ A 0.11 μ A	Black Red	+ -
Simpson 260	Rx 100	1.5V	1 mA	Red Black	+ -
Simpson 269	Rx 1K	1.5V	0.82 mA	Black Red	+ -
Triplet 630	Rx 100 Rx 1K	1.5V 1.5V	3.25 mA 325 μ A	Varies with Serial Number	
Triplet 310	Rx 10 Rx 100	1.5V 1.5V	750 μ A 75 μ A	Varies with Serial Number	

4-21. REPAIR PROCEDURES.

4-22. General information and procedures for the repair of printed circuit boards are given in paragraphs 4-23 through 4-28. Paragraphs 4-29 through 4-49 list procedures for the repair or replacement of major assemblies and connectors.

4-23. PRINTED CIRCUIT BOARDS.

4-24. The printed circuit boards in the 8745A are of the plated-through type consisting of metallic conductors bonded to both sides of insulating material. Soldering can be done from either side of the board with equally good results. Table 4-3 lists required tools and materials. Following are recommendations and precautions pertinent to printed circuit repair work.

a. Avoid unnecessary component substitution; it can result in damage to the circuit board and adjacent components.

b. Do not use a high-power soldering iron. Excessive heat may lift a conductor or damage the board.

c. Use a suction device (Table 4-3) or wooden toothpick to remove solder from component mounting holes.

DO NOT USE A SHARP METAL OBJECT SUCH AS AN AWL OR TWIST DRILL FOR THIS PURPOSE. SHARP OBJECTS MAY DAMAGE THE PLATED-THROUGH CONDUCTOR.

d. After soldering, remove excess flux from the soldered area and apply a protective coating to prevent contamination and corrosion. See Table 4-3 for recommendations.

4-25. A broken or burned section of conductor can be repaired by bridging the damaged section with a length of tinned copper wire. Allow adequate overlap and remove any varnish from etched conductor before soldering wire into place.

4-26. COMPONENT REPLACEMENT. A general procedure for replacing a component is as follows:

a. Remove defective component from circuit board.

b. Remove solder from mounting holes using a suction desoldering aid (Table 4-3) or wooden toothpick.

c. Shape leads of replacement component to match mounting hole spacing.

d. Insert component leads into mounting holes and position component as original was positioned.

Table 4-3. Printed Circuit Soldering Equipment

Item	Use	Specification	Item Recommended
Soldering Tool	Soldering Unsoldering	Wattage ratings: 37.5 Tip Temp: 750 - 800° F Tip Size: 1/8" OD	Ungar #776 Handle with Ungar #1237 Heating Unit
Soldering Tip general purpose	Soldering Unsoldering	Shape: chisel Size: 1/8"	Ungar #PL113
De-soldering aid	Unsoldering multi- connection components (e.g., sockets)	Suction device to remove molten solder from connection	Soldapullt by the Edsyn Company, Arleta, California
Resin (flux) solvent	Remove excess flux from soldered area before application of protective coating	Must not dissolve etched circuit base board material or conductor bonding agent	Freon Acetone Lacquer Thinner Isopropyl Alcohol (100% dry)
Solder	Component replacement Circuit board repair Wiring	Resin (flux) core, high tin content (60/40 tin/lead), 18 gauge (SWG) preferred	
Protective Coating	Contamination, corrosion protection after soldering	Good electrical insulation, corrosion-prevention properties	Silicone Resin such as GE DRI-FILM* 88

*General Electric Co., Silicone Products Dept., Waterford, New York, USA

DO NOT FORCE LEADS OF REPLACEMENT COMPONENT INTO MOUNTING HOLES. Sharp lead ends may damage plated-through conductor.

NOTE

Axial lead components, such as resistors and tubular capacitors, can be replaced without unsoldering. Clip leads near body of defective component, remove component and straighten leads left in board. Wrap leads of replacement component one turn around original leads. Solder wrapped connection and clip off excess lead.

4-27. TRANSISTOR REPLACEMENT. A general procedure for replacing a transistor is as follows:

- a. Do not apply excessive heat. See Table 4-3 for soldering tool specifications.
- b. Use a heat sink such as pliers or hemostat between transistor body and hot soldering iron.
- c. When installing a replacement transistor, ensure sufficient lead length to dissipate heat of soldering by maintaining about the same length of exposed lead as used for the original transistor.

NOTE

If one of the RF source Relay Driver transistors (A3Q11, A3Q12, A3Q13, or A3Q14) fails, additional current will be drawn through one of the other driver transistors. This additional current may not burn out the transistor, however, it may damage the transistor and a repeat failure may occur within the next few weeks of operation. Therefore, when replacing A3Q11, A3Q12, A3Q13, or A3Q14, replace all four transistors before applying power to the 8745A.

4-28. DIODE REPLACEMENT. Solid state diodes are in many physical forms. This sometimes results in confusion as to which lead or connection is for the cathode (negative) or anode (positive), since not all diodes are marked with the standard symbols. If doubt exists as to polarity, an ohmmeter may be used to determine the proper connection. It is necessary to know the polarity of the ohms lead with respect to the common lead for the ohmmeter used. Ohms lead polarities for some common ohmmeters are shown in Table 4-3. When the ohmmeter indicates the least diode resistance, the cathode of the diode is connected to the ohmmeter lead which is negative with respect to the other lead.

NOTE

Diode replacement instructions are the same as those for transistor replacement.

4-29. RF SOURCE RELAY (A11) REPLACEMENT.

4-30. REMOVAL. To remove A11:

- a. Remove top and bottom covers and the right rear side-panel cover.

4-4

- b. Disconnect A11's green and white wires at the A5 assembly.

- c. Loosen connectors of coaxial cables W9 and W10 at both ends using a 3/4 inch open-end wrench, and remove the cables.

- d. Remove the two screws holding A11 to the rear-panel and remove A11. Unsolder the green and white wires from A11. These wires are to be installed on the replacement assembly.

4-31. INSTALLATION. To install A11:

- a. Insert the RF INPUT connector of A11 through the rear-panel and secure A11 to the rear-panel with two 6-32 x 5/16 inch screws with internal lock washer. Position A11 so that the side with the flat plate is facing the side panel.

- b. Install W9 and W10 and tighten their large hex nuts.

- c. Connect the white wire to the top of A11 and to the four post pad on A5 where three other white wires are connected. Connect the green wire to the bottom of A11 and to the four post pad on A5 where three other green wires are connected.

4-32. RF SOURCE RELAY (A9 OR A10) REPLACEMENT.

4-33. REMOVAL. To remove A9 or A10:

- a. Remove A11 using instructions in paragraph 4-30.

- b. Remove the two screws holding J1 (36-pin connector).

- c. Remove J1's outer cover and slide the connector through the rear panel.

- d. If the 8745A is equipped with a rear-panel coaxial link, remove the coaxial link and disconnect each rear-panel connector as follows:

- (1) Remove the large thin nut securing connector body to rear panel using a 3/4-inch open-end wrench.

- (2) Push connector from inside the 8745A to expose the flat surfaces of connector body, apply an 11/16-inch open-end wrench to these flat surfaces, and apply a 7/16-inch open-end wrench to the small brass hex nut (cable terminator) inside the 8745A. Unscrew the stainless steel connector body.

- e. Remove the rear panel by removing four screws, two in the side panel, and two in the rear panel.

- f. Disconnect all push-on wires from the A5 assembly.

- g. Remove the A5 assembly by removing its four mounting screws.

- h. A9 or A10 may now be removed by unscrewing the knurled nut of connector at the directional coupler. Unsolder the green and white wires from the coaxial switch to be replaced. These wires are to be installed on the new assembly.

4-34. INSTALLATION. To install A9 or A10:

a. Connect the knurled nut of the stainless steel connector to the directional coupler. Position the relay so that its termination is closest to the sub deck.

b. Mount the A5 assembly to the A9 and A10 assemblies with four 4-40 x 1/4 inch pan head screws and lock washers (connect the grounding lug under the top rear mounting screw).

c. Connect the push-on wires to the A5 assembly as follows:

- (1) Connect the two orange wires to the pad on the A5 assembly marked ORN.
- (2) Connect the two blue wires to the pad on the A5 assembly marked ELU.
- (3) Connect the three white wires to the pad on the A5 assembly marked WHT.
- (4) Connect the three green wires to the pad on the A5 assembly marked GRN.
- (5) Connect the violet wires, one from A9 and one from A10, to the A5 pad marked VIO which is closest to each coaxial switch.

d. Install the rear panel and secure with two 8-32 x 1/4-inch flat-head screws with lock washers in the side panel, and two 6-32 x 5/16-inch pan-head screws with lock washers in the rear panel.

e. If the 8745A is equipped with a rear-panel coaxial link, replace the rear-panel connectors as follows:

- (1) Push the cable, terminator and bead attached, through the appropriate rear-panel hole and screw on the connector body. If the nut used to secure the connector body has been removed, replace nut and washer on cable before attaching connector body.
- (2) Apply an 11/16-inch, open-end wrench to the flat surfaces on the connector body and tighten the connector body (do not apply excessive torque to connector body or damage to the bead may occur).
- (3) Secure the connector to rear panel with large thin nut.

f. Push J1 (36-pin connector) through hole in rear-panel, replace J1's cover, and secure connector to the rear panel with two 2-56 x 1/2-inch pan head screws.

g. Replace A11 using instructions in paragraph 4-31.

4-35. DIRECTIONAL COUPLER (DC1 AND DC2) REPLACEMENT.

4-36. The directional couplers must be replaced in pairs. Refer to parts list for pair part number.

4-37. REMOVAL. To remove the couplers:

a. Remove A9, A10, and A11 using instructions in Paragraphs 4-32 and 4-30.

b. Remove the A5 assembly.

c. Disconnect cables W7 and W8 from DC1 and DC2 as follows:

- (1) Remove right rear side panel and carrying handle assembly by removing the two side-panel screws.
- (2) Remove the two A8 mounting bracket screws.
- (3) Disconnect the stainless steel knurled connectors of W7 and W8 from DC1 and DC2.

d. Disconnect cables W4 and W5 from A7 as follows:

- (1) Loosen the stainless steel knurled connectors of W4 and W5 at A7 (Do not attempt to disconnect these connectors with A7 mounting bracket secured).

- (2) Remove the two screws from the A7 mounting bracket.

- (3) Disconnect W4 and W5 connectors from A7.

e. On units not equipped with rear-panel coaxial link remove W6 (coaxial cable from line stretcher to A8).

f. Remove the two screws securing directional coupler rear mounting bracket (bottom of instrument).

g. Remove the four screws, two on top and two on bottom, securing the directional couplers' front mounting bracket, and slide the directional couplers out the rear of the instrument.

h. Disconnect W4 and W5 from DC1 and DC2.

i. Disassemble the directional couplers and their mounting brackets as follows:

- (1) Remove the stainless steel lock nut and retaining nut from rear of bracket assembly. Remove the rear mounting bracket.
- (2) Remove the stainless steel nut from the coupler retaining bracket, and remove couplers.

4-38. INSTALLATION. To install the couplers:

a. Assemble the couplers and their mounting brackets as follows:

- (1) Insert the APC-7 connector end into the front mounting bracket. Position couplers with unpainted side up (bottom of front bracket has recess for Transistor Fixture guide).

(2) Install the coupler retaining bracket and secure with stainless steel 1/4-20 nut.

(3) Install the rear mounting bracket and secure with 1/4-20 retaining nut and 1/4-20 lock nut.

b. Connect W4 and W5 to DC1 and DC2. Tighten connectors with cables positioned so they will mate with A7 connectors when assembly is installed in instrument.

c. Slide the directional couplers and mounting brackets into place through the rear of the instrument and secure the front mounting bracket with four 6-32 x 1/2 inch flat head screws, two on top and two on bottom. Secure the rear mounting bracket with two screws on bottom.

d. Connect W4 and W5 to A7 and secure A7 mounting bracket with two 6-32 x 1/2 inch pan head screws and clamping bar.

e. Connect cables W7 and W8 to DC1 and DC2 and secure A8 with two 6-32 x 1/2 inch flat head screws and lock washers.

f. On units not equipped with a rear-panel coaxial link, install W6.

g. Install the A3 Assembly.

h. Install A9 and A10 using instructions in Paragraph 4-34 and install A11 using instructions in Paragraph 4-31.

4-39. LINE STRETCHER (A6) REPLACEMENT.

4-40. REMOVAL. To remove line stretcher:

a. Remove top and bottom covers and the left rear side-panel cover.

b. Remove the REFERENCE and TEST output connectors as follows:

(1) Remove the large thin nut securing connector body to rear panel using a 3/4-inch open-end wrench. (Remove the cross bar above connectors for access to retaining nuts).

(2) Push connector from inside the 8745A to expose the flat surfaces of connector body, apply an 11/16-inch open-end wrench to the small brass hex nut (cable terminator) inside the 8745A. Unscrew the stainless steel connector body.

c. Remove the A7 assembly as follows:

(1) Loosen the type N connectors of the three coaxial cables (W2, W4, and W5) attached to the A7 assembly. Do not attempt to disconnect these connectors with the A7 mounting bracket secured.

(2) Remove the two screws from the A7 mounting bracket.

(3) Disconnect W4 and W5 connectors from the A7 assembly.

(4) Disconnect and remove W2.

d. Disconnect W13 (W6 on instruments with serial numbers prefixed 823-) from the A6 assembly.

e. Disconnect and remove W4 and W5.

f. Remove the front-panel line stretcher crank.

g. Remove the power on-off pushbutton.

h. Remove the sub-deck by removing four screws, two accessible through the left side panel, and two securing the opposite side, accessible from the bottom.

i. Remove the two screws from the line stretcher's rear mounting bracket and the two screws from the bottom of the front mounting bracket.

j. Remove the two screws from the top of the front mounting bracket.

k. Slide the line stretcher out the rear of the instrument.

m. Remove W3 and the front and rear mounting brackets from the line stretcher.

4-41. INSTALLATION. To install line stretcher:

a. Attach the front mounting bracket to the line stretcher with three 6-32 x 3/16-inch flat head screws.

b. Attach the rear mounting bracket to the line stretcher with two 6-32 x 5/16-inch pan head screws.

c. Connect W3 to the line stretcher and position cable so that it will extend through the proper hole in the sub-deck when the line stretcher is in place.

d. Slide the line stretcher and its mounting brackets into place through the rear of the instrument and secure the front mounting bracket with four 6-32 x 3/16-inch flat head screws, two on top and two on bottom.

e. Secure the rear mounting bracket with two 8-32 x 5/16-inch pan head screws.

f. Install the sub-deck and secure with four screws, two 6-32 x 1/2-inch pan head screws through the left side panel, and the opposite side with two 6-32 x 1/2-inch pan head screws and nuts accessible from the bottom.

g. Install the power on-off pushbutton. Be sure the lamp is making good contact by allowing a small amount of clearance between the cap nut and the knurled retaining nut.

h. Install the front panel line stretcher crank.

- i. Connect W2 to the center port of the A7 assembly.
- j. Connect W4 and W5 to DC1 and DC2 and to the A7 assembly.
- k. Secure the A7 assembly with two 6-32 x 1/2-inch pan head screws and clamping bar.
- m. Connect W13 (W6 on instruments with serial numbers prefixed 823-) to the line stretcher.
- n. Install the REFERENCE and TEST output connectors as follows:
 - (1) Push the cable, with terminator and bead attached, through the appropriate sub-deck hole and screw on the connector body (if the nut used to secure the connector body has been removed, replace nut and washer on cable before attaching connector body).
 - (2) Apply an 11/16-inch open-end wrench to the flat surfaces on the connector body and tighten the connector body. Do not apply excessive torque to connector body or damage to bead may occur.
 - (3) Secure the connector to rear panel with large thin nut.
- p. Install the cross bar and cable clamps.
- q. Secure sub-deck with a 4-40 x 1/4-inch flat head screw above both the REFERENCE and TEST channel output ports.

4-42. RF CONNECTOR REPAIR.

4-43. FRONT PANEL INPUT PORT A AND B. INPUT PORT A is part of a directional coupler and so is INPUT PORT B. The center conductor of each connector is soldered to a directional coupler stripline; any rotational force on the center conductor may damage the directional coupler. Repair of the directional coupler requires tuning for directivity and phase matching; therefore, field repair is not recommended. However, the connector's inner conductor contact and coupling assembly may be replaced.

4-44. For replacing an inner conductor contact a contact extractor tool* (HP part number 5060-0236) is required. To replace an inner conductor contact:

- a. Open jaws of contact extractor tool by pulling T-bar toward the black handle.
- b. Holding jaws open, place tool over inner conductor contact holder, and align jaws with contact by pushing tool onto connector as far as it will go.
- c. Without moving tool, allow jaws to close.
- d. Remove contact by gently pulling tool straight outward from connector. To release contact from tool, reopen jaws.

*Included in the HP 11591A APC-7 Connector Tool Kit.

e. Push the replacement contact into the inner conductor contact holder until it snaps into place. When properly installed, the contact is self-retaining and protrudes slightly from the inner conductor, the spaces between the contact segments are equal, and the flat contacting surfaces form a uniform ring.

f. Check for correct installation by inspecting contact and testing its spring action. To test spring action, press lightly inward on the contact with fingernail or pencil eraser. As pressure is released the contact should move outward, or follow, slightly. If not, the contact is defective and should be replaced.

4-45. For replacing a coupling assembly a special spanner wrench* (HP part number 5060-0237) and open-end wrench* (HP part number 8710-0877) are required. To replace a coupling assembly:

- a. Remove the directional couplers using procedures in Paragraph 4-37.
- b. Partially extend coupling sleeve to serve as guide for spanner wrench.
- c. Place the open-end wrench over the flats on the outer conductor behind the coupling nut.

CAUTION

Do not apply more than 30 in.-lbs of rotational force in either direction on the outer conductor. Any rotational force may be transmitted to the inner conductor via the bead and damage the directional coupler.

d. Position spanner wrench so both pegs engage holes in coupling sleeve assembly.

e. Press spanner firmly inward against connector to prevent wrench from disengaging and damaging exposed contacting surface of outer conductor. Unscrew sleeve assembly by turning wrench counterclockwise, while holding open-end wrench firmly to prevent outer conductor from rotating.

f. Thread coupling nut onto coupling sleeve.

g. Thread coupling assembly onto outer conductor finger tight.

h. Fully retract the coupling sleeve, then just start to extend it. Place the open-end wrench over the flats on the outer conductor behind the coupling nut. Then extend the coupling nut as far as it will go to obtain as much alignment and as possible for the spanner wrench.

i. Press firmly inward on the spanner wrench while tightening to prevent the pegs from disengaging and damaging the critical contacting surfaces of the connector. Tighten sleeve assembly by turning wrench clockwise, while holding open-end wrench firmly to prevent outer conductor from rotating.

j. Install directional couplers using procedures in Paragraph 4-38.

4-46. **RF INPUT PORT.** The RF INPUT port is part of the input coaxial switch A11. If the input port connector is damaged, replace the A11 Assembly using procedures in Paragraph 4-29.

4-47. **REFERENCE AND TEST CHANNEL OUTPUT AND REAR-PANEL COAXIAL LINK CONNECTORS.** To remove a connector refer to Figure 4-2 and:

a. Remove the large thin nut securing connector body to rear panel, using a 3/4-inch open-end wrench.

b. Push connector from inside the 8745A to expose the flat surfaces of connector body, apply an 11/16-inch open-end wrench to these flat surfaces, and apply a 7/16-inch open-end wrench to the small brass hex nut (cable terminator) inside the 8745A. Unscrew the stainless steel connector body.

c. Remove the bead assembly by pulling it from the cable's center conductor.

d. To remove the cable terminator, hold the cable terminator with one open-end wrench and loosen the stainless steel lock nut with a second open-end wrench. With the lock nut loose, slide the cable terminator off the cable.

4-48. To replace a connector refer to Figure 4-2 and:

a. Slide the stainless steel lock nut onto the cable.

b. Slide the cable terminator onto the cable. Be sure the cable's outer conductor is seated against the shoulder inside the cable terminator.

c. Thread the stainless steel lock nut onto the cable terminator and tighten the lock nut with one open-end wrench while holding the cable terminator with another open-end wrench.

d. Insert the bead assembly onto the cable's center conductor and seat the bead against the cable terminator.

e. Slide the large, thin connector-securing nut and washer onto the cable, and push the cable through the hole in the rear panel. Thread the stainless steel connector body onto the cable terminator, and tighten the connector body with an open-end wrench applied to the flats on the connector body. Do not apply more than 30 in.-lbs of force to connector body.

f. Thread the large thin connector securing nut onto the back of the connector body and tighten securely.

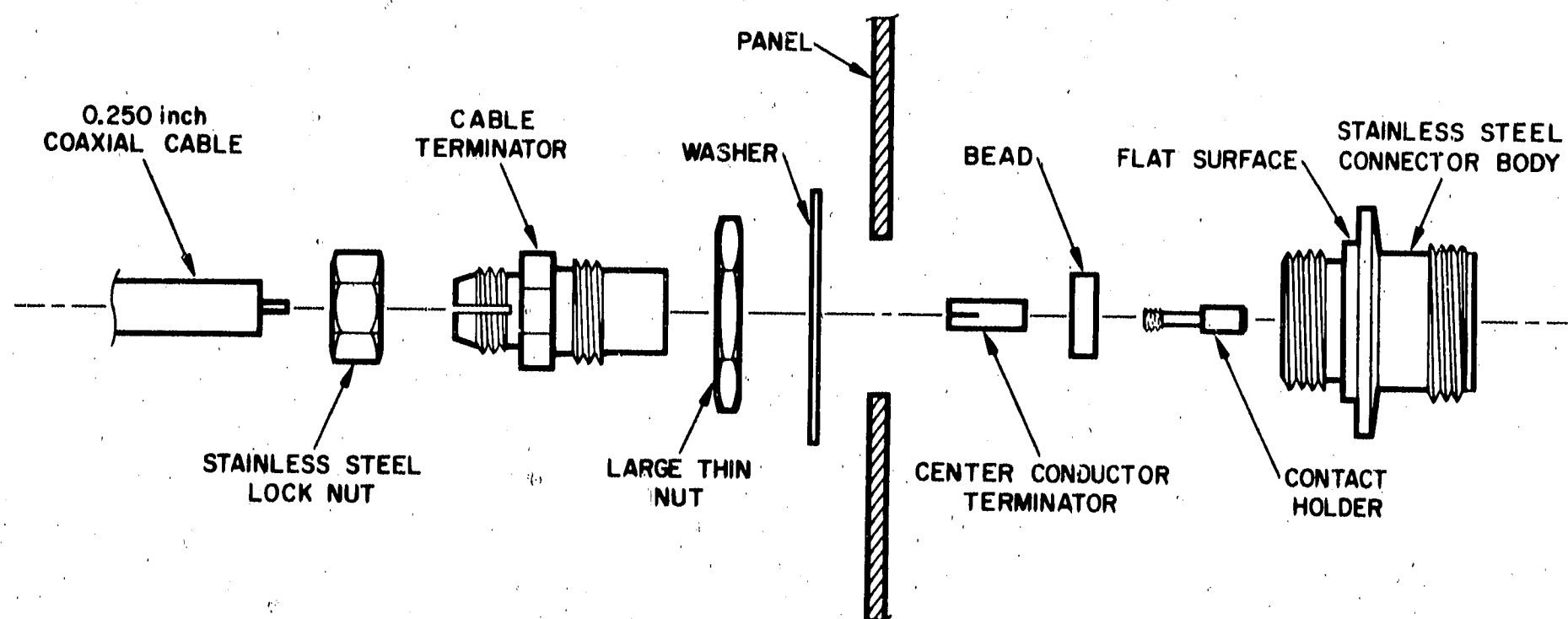

Figure 4-2. REFERENCE and TEST Channel Output and Coaxial Link Connectors Exploded View

Table 4-4. Recommended Test Equipment

Instrument	Critical Specifications	Use*	Recommended HP Model
Sweep Oscillator	Frequency Range : 0.1 to 2 GHz Output Power: 1 mW minimum into 50 ohms Power Variation: 20 dB maximum VSWR: 3.1, maximum	P	8690A, B/8699B
Network Analyzer	No substitute may be used	P	8410A/8411A/8413A, 8414A
Time Domain Reflectometer	No substitute may be used	T	140A/1415A
Short	Connector: Precision 7mm	P	11565A
Low Reflection 50-ohm Load	Impedance: 50 ohms Power Ratings: 10 mW minimum VSWR: 1.01, maximum Connector: Precision 7mm	P	HO1-909A
Universal Extension	50-ohm semi-rigid coaxial cable with Precision 7mm connectors for connecting INPUT PORT A to INPUT PORT B. VSWR: 1.06, maximum	P	11604A
Microwave Power Meter	Frequency Range: 0.1 to 2 GHz Power Range: 0 to -25 dBm	T	432A/8478B Option 11
DC Volt-Ohmmeter	Voltage Range: 0 to 30 Volts DC Voltage Accuracy: 3% Ohms Range: 0 to 100	T	427A
50-ohm Termination	Impedance: 50 ohms Power Rating: 20 mW, minimum Connector: Type N male VSWR: 1.1, maximum	T	908A
Oscilloscope	Bandwidth: 500 KHz minimum Horizontal External Input: Sensitivity compatible with Sweep Oscillator sweep output voltage.	P	1200A, B 120B 130C
<p>* P = Performance Testing</p> <p>T = Troubleshooting</p>			

TEST	DESCRIPTION AND PROCEDURE
	<p style="text-align: center;">NOTE</p> <p>The time required to complete the performance test can be significantly reduced by testing across broader frequency ranges than those indicated on the 8410A frequency range selector. Most Network Analyzers can track input frequencies over more than one octave. Factors involved in achieving greater frequency coverage are sweep width and sweep time on the sweep oscillator and the settings of the sweep stability and frequency range selector on the network analyzer. The suggested frequency bands are: 100 to 400 MHz, 400 to 900 MHz, and 900 MHz to 2.0 GHz. To extend the lower frequency band it may be necessary to adjust the 8410A frequency range selector to the 1.0 to 2.0 GHz range.</p>
1	<p>SPECIFICATION TESTED</p> <p>Directivity: 36 dB ($\rho = 0.016$) from 0.1 to 1.0 GHz 32 dB ($\rho = 0.025$) from 1.0 to 2.0 GHz</p> <hr/> <p>DESCRIPTION</p> <p>Directivity is tested using each internal coupler to measure the reflection coefficient of a standard termination. The reflection coefficient of the termination is cancelled out at single frequencies and the resultant is coupler directivity.</p> <hr/> <p>TEST SETUP</p>  <p style="text-align: center;">*HP Part No. 08745-20064 for test units equipped with rear panel coaxial link.</p>

Figure 4-3. Performance Test (Sheet 1 of 6)

TEST	DESCRIPTION AND PROCEDURE
1 (Contd)	<p>PROCEDURE</p> <ol style="list-style-type: none"> a. Connect equipment as shown in test setup. b. Calibrate the 8414A display as follows: <ol style="list-style-type: none"> 1. Connect APC-7 short to 8745A Port A and depress pushbuttons A and S_{11}. 2. Set Sweep Oscillator to automatic sweep. <p style="text-align: center;">NOTE</p> <p>Most Network Analyzers will phase lock over more than one octave. To cover the entire operating range of the 8745A in a minimum number of frequency segments, set the Sweep Oscillator end frequencies to cover the broadest segment of the 0.1 to 2.0 GHz range to which the Network Analyzer will phase lock.</p> <ol style="list-style-type: none"> 3. Adjust the Network Analyzer and Sweep Oscillator controls for best phase lock over the frequency band selected. 4. Push and hold 8414A BEAM CTR control and adjust HORIZ POS and VERT POS controls to place dot in the center of the polar display. 5. Adjust the 8410A TEST CHANNEL GAIN and AMPLITUDE VERNIER controls for a trace on the outer circle of the CRT graticule. c. Remove APC-7 short and replace with 50-ohm termination. d. Increase 8410A TEST CHANNEL GAIN by 32 dB for 1.0 to 2.0 GHz. This changes the full-scale reflection calibration from 1.0 to 0.025 (directivity of 32 dB) at the outer circle. For 0.1 to 1.0 GHz increase the TEST CHANNEL GAIN by 36 dB to calibrate the outer circle for reflection coefficient of 0.016 (directivity of 36 dB). <p style="text-align: center;">NOTE</p> <p>The 8414A display is now the combination of coupler directivity and reflection coefficient of the 50-ohm termination.</p> e. The 8414A display of directivity should be within the outer circle. If the directivity does not meet specifications, separate the coupler directivity and reflection coefficient of the 50-ohm termination as follows: <ol style="list-style-type: none"> 1. Set the Sweep Oscillator to CW and select the frequency which corresponds to the point of greatest reflection on the 8414A display. 2. Insert two or more sections of air line, one at a time, between the 8745A and the 50-ohm termination to phase the load. Use a grease pencil or felt pen to mark the location of the 8414A display for each length of line inserted. Obtain a minimum of four points and draw a circle connecting each grease pencil mark. Variations from a circle are due to reflections of the air line. The center of this circle is the tip of the directivity vector. The magnitude of this point should not exceed 0.016 from 0.1 to 1.0 GHz, 0.025 from 1.0 to 2.0 GHz. f. Repeat steps <u>b</u> through <u>e</u> for other frequency segments as necessary to cover the range of 0.1 to 2.0 GHz. g. Connect APC-7 short to 8745A port B, depress pushbuttons B and S_{11}, and repeat steps <u>b</u> (2) through <u>f</u>.

Figure 4-3. Performance Test (Sheet 2 of 6)

TEST	DESCRIPTION AND PROCEDURE
2	<p>SPECIFICATION TESTED</p> <p>Load Match: Reflection Coefficient (VSWR)</p> <p><0.10 (<1.22), 100-200 MHz.</p> <p><0.063 (<1.13), 200-2000 MHz.</p>
	<p>DESCRIPTION</p> <p>Input (test) port VSWR is tested using the internal coupler associated with the other port in a reflectometer setup canceling at single frequencies, if necessary, coupler directivity and other reflections.</p>
	<p>TEST SETUP</p>  <p>*HP Part Number 08745-20064 for test units equipped with rear-panel coaxial link.</p>
	<p>PROCEDURE</p> <ol style="list-style-type: none"> a. Connect equipment as shown in test setup. b. Calibrate the 8414A display as follows: <ol style="list-style-type: none"> 1. Connect APC-7 short to port A arm of Universal Extension and depress pushbuttons A and S_{11}. 2. Set Sweep Oscillator to automatic sweep.

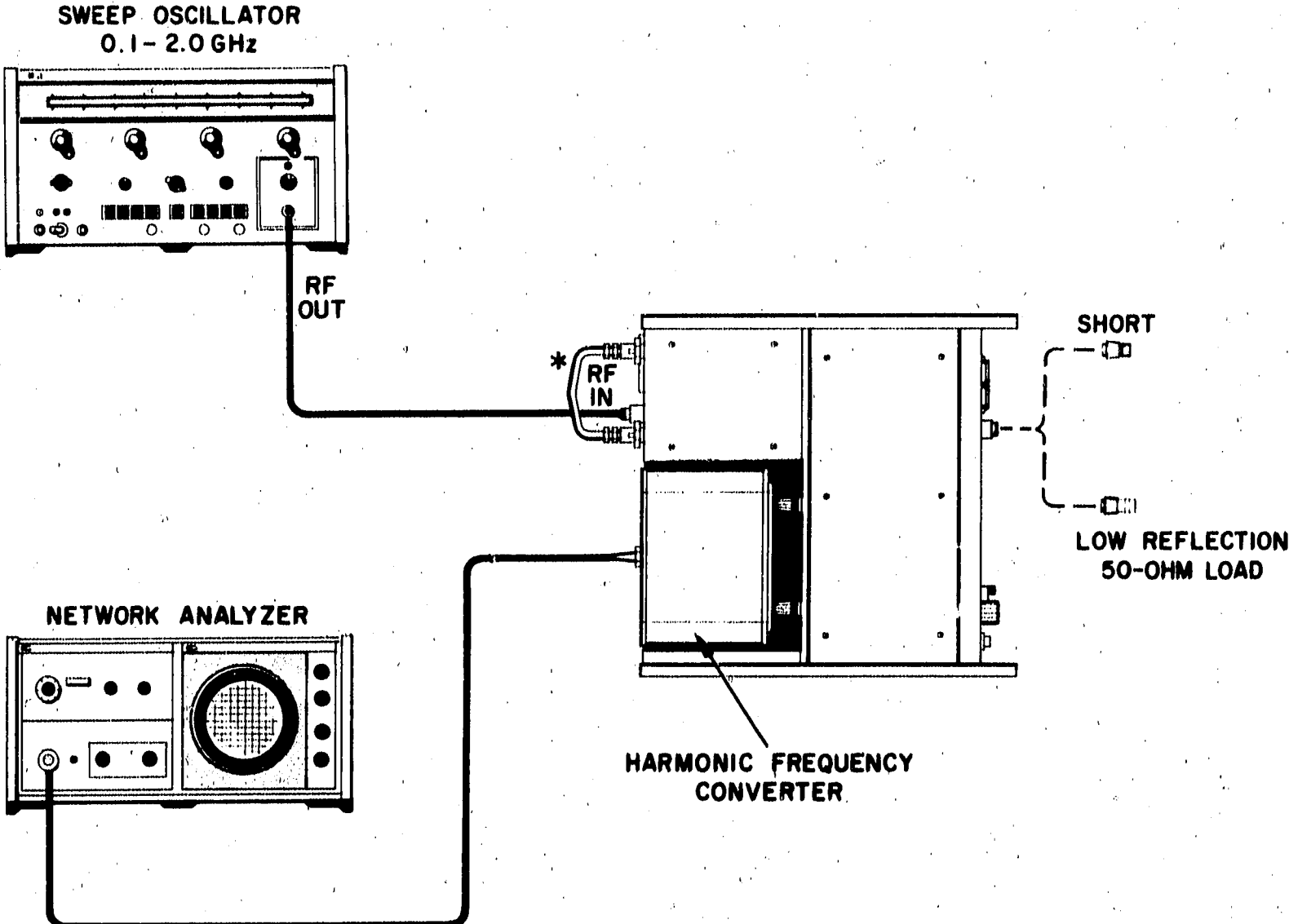
Figure 4-3. Performance Test (Sheet 3 of 6)

TEST	DESCRIPTION AND PROCEDURE
2 (Contd)	<p style="text-align: center;">NOTE</p> <p>Most Network Analyzers will phase lock over more than one octave. To cover the entire operating range of the 8745A in a minimum number of frequency segments, set the Sweep Oscillator end frequencies to cover the broadest segment of the 0.1 to 2.0 GHz range to which the Network Analyzer will phase lock.</p> <ol style="list-style-type: none"> 3. Adjust the Network Analyzer and Sweep Oscillator controls for best phase lock over frequency band selected. 4. Push and hold 8414A BEAM CTR control and adjust HORIZ POS and VERT POS controls to place dot in the center of the polar display. 5. Adjust the 8410A TEST CHANNEL GAIN and AMPLITUDE VERNIER controls for a trace on the outer circle of the CRT graticule. <p>c. Remove the APC-7 short and connect the two arms of the Universal Extension together (8745A port A connected to port B).</p> <p>d. Increase 8410A TEST CHANNEL GAIN by 20 dB for 0.1 to 0.2 GHz. This changes the full-scale reflection calibration from 1.0 to 0.1 at the outer circle. For 0.2 to 2.0 GHz, increase the TEST CHANNEL GAIN by 24 dB to calibrate the outer circle for reflection coefficient of 0.063.</p> <p>e. The 8414A display of reflection coefficient should be within the outer circle. If the reflection coefficient does not meet specifications, separate the Universal Extension reflection coefficient and coupler directivity from the reflection coefficient of the 8745A as follows:</p> <ol style="list-style-type: none"> 1. Set the Sweep Oscillator to CW and select the frequency which corresponds to the point of greatest reflection on the 8414A display. 2. Terminate the main line of the reflectometer with a low reflection load. When checking the input reflection of port A: <ol style="list-style-type: none"> (a) Disconnect the Universal Extension from port B and loosen the connection at port A. (b) Swing the Universal Extension lower connector above the 8745A and tighten the connection at port A. (c) Connect Low Reflection 50-ohm load to the free connector of the Universal Extension. <p>When checking the input reflection of port B:</p> <ol style="list-style-type: none"> (a) Disconnect the Universal Extension from port A and loosen the connection at port B. (b) Swing the Universal Extension upper connector below the 8745A and tighten the connection at port B. (c) Connect Low Reflection 50-ohm load to the free port of the Universal Extension.

Figure 4-3. Performance Test (Sheet 4 of 6)

TEST	DESCRIPTION AND PROCEDURE
2 (Contd)	<p>3. Without depressing BEAM CTR adjust 8414A HORIZ POS and VERT POS controls to place dot at the CRT center.</p> <p>4. Disconnect the 50-ohm load and reconnect the Universal Extension in the normal manner. The 8414A display is now the input reflection coefficient only. The equivalent directivity of this measurement is the return loss of the 50-ohm load.</p> <p>f. Connect Short to port B arm of Universal Extension, depress 8745A pushbuttons B and S_{11} and repeat steps b(2) through e.</p> <p>g. Repeat steps b through f for other frequency segments as necessary to cover the range of 0.1 to 2.0 GHz.</p>
3	<p>SPECIFICATION TESTED</p> <p>Source Match: Reflection coefficient (VSWR) < 0.057 (< 1.12), 0.11 - 2.0 GHz.</p> <p>DESCRIPTION</p> <p>Source match is tested by measuring the change in magnitude of a maximum reflection when the phase of the reflected signal is varied.</p> <p>TEST SETUP</p>  <p>*HP Part No. 08745-20064 for test units equipped with rear panel coaxial link.</p>

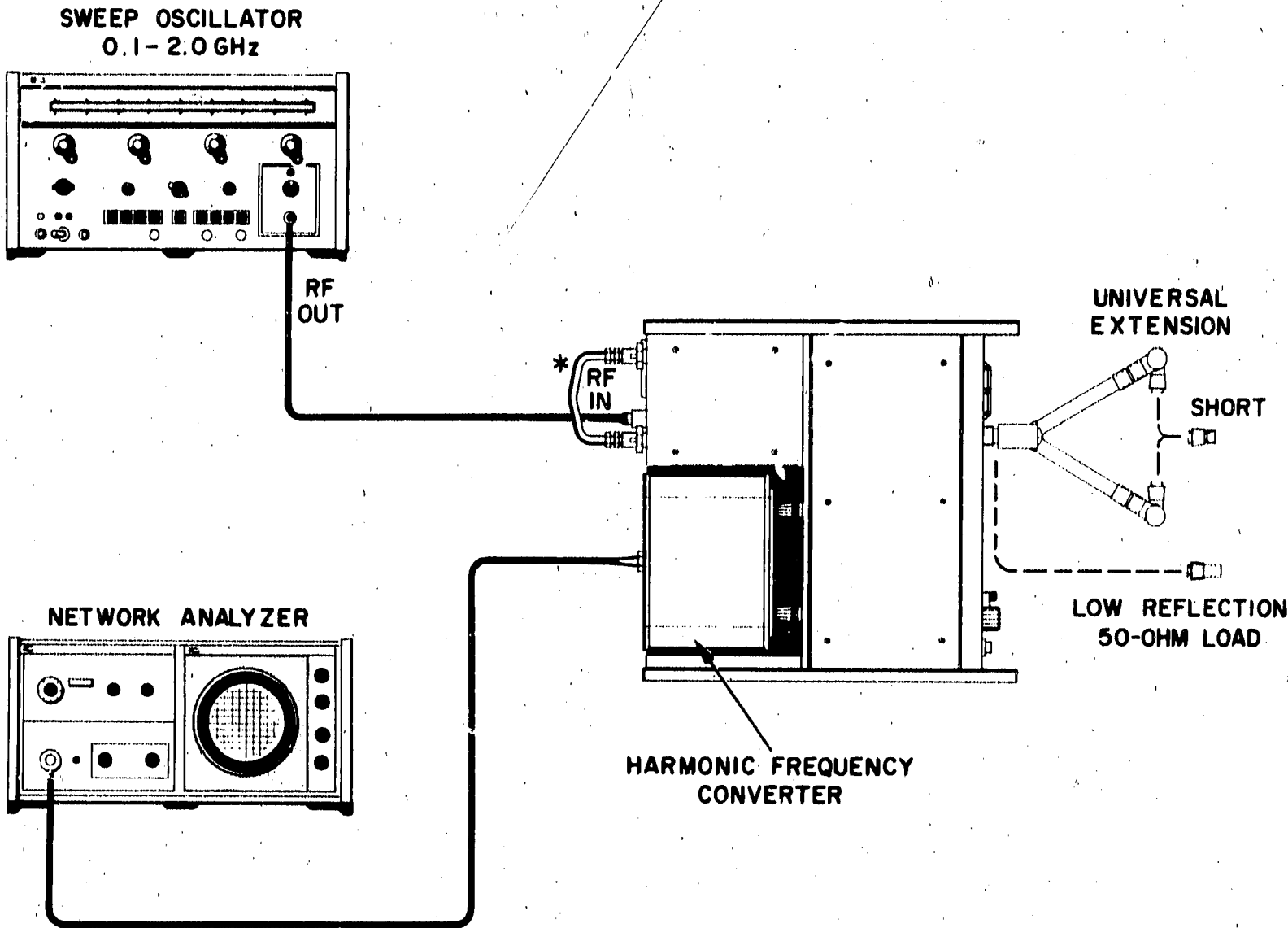
Figure 4-3. Performance Test (Sheet 5 of 6)

TEST	DESCRIPTION AND PROCEDURE
3 (Contd)	<p>PROCEDURE</p> <ol style="list-style-type: none"> a. Connect equipment as shown in test setup. b. Connect APC-7 short to 8745A port A and depress pushbuttons A and S₁₁. c. Set Sweep Oscillator to automatic sweep. <p style="text-align: center;">NOTE</p> <p>Most Network Analyzers will phase lock over more than one octave. To cover the entire operating range of the 8745A in a minimum number of frequency segments, set the Sweep Oscillator end frequencies to cover the broadest segment of the 0.1 to 2.0 GHz range to which the Network Analyzer will phase lock.</p> <ol style="list-style-type: none"> d. Adjust the Network Analyzer frequency range selector and sweep stability control, the Sweep Oscillator sweep time and sweep width, and the Oscilloscope vertical and horizontal positioning controls to display the amplitude output of the 8413A. e. Calibrate the Oscilloscope vertical sensitivity to display 0.25 dB/cm. f. Draw the oscilloscope trace on the face of the CRT with a grease pencil. g. Remove the APC-7 short and draw the trace of the open circuit on the face of the CRT. h. The maximum deviation between traces should not exceed 1.0 dB indicating a VSWR < 1.12. <p style="text-align: center;">VSWR = antilog 0.05 (deviation between traces in dB)</p> i. Repeat steps b through h for other frequency segments as necessary to cover the range of 0.1 to 2.0 GHz. j. Connect APC-7 short to 8745A port B, depress pushbuttons B and S₁₁, and repeat steps f through h for each frequency segment to cover the range of 0.1 to 2 GHz.

Figure 4-3. Performance Test (Sheet 6 of 6)

Table 4-5. Performance Test Record

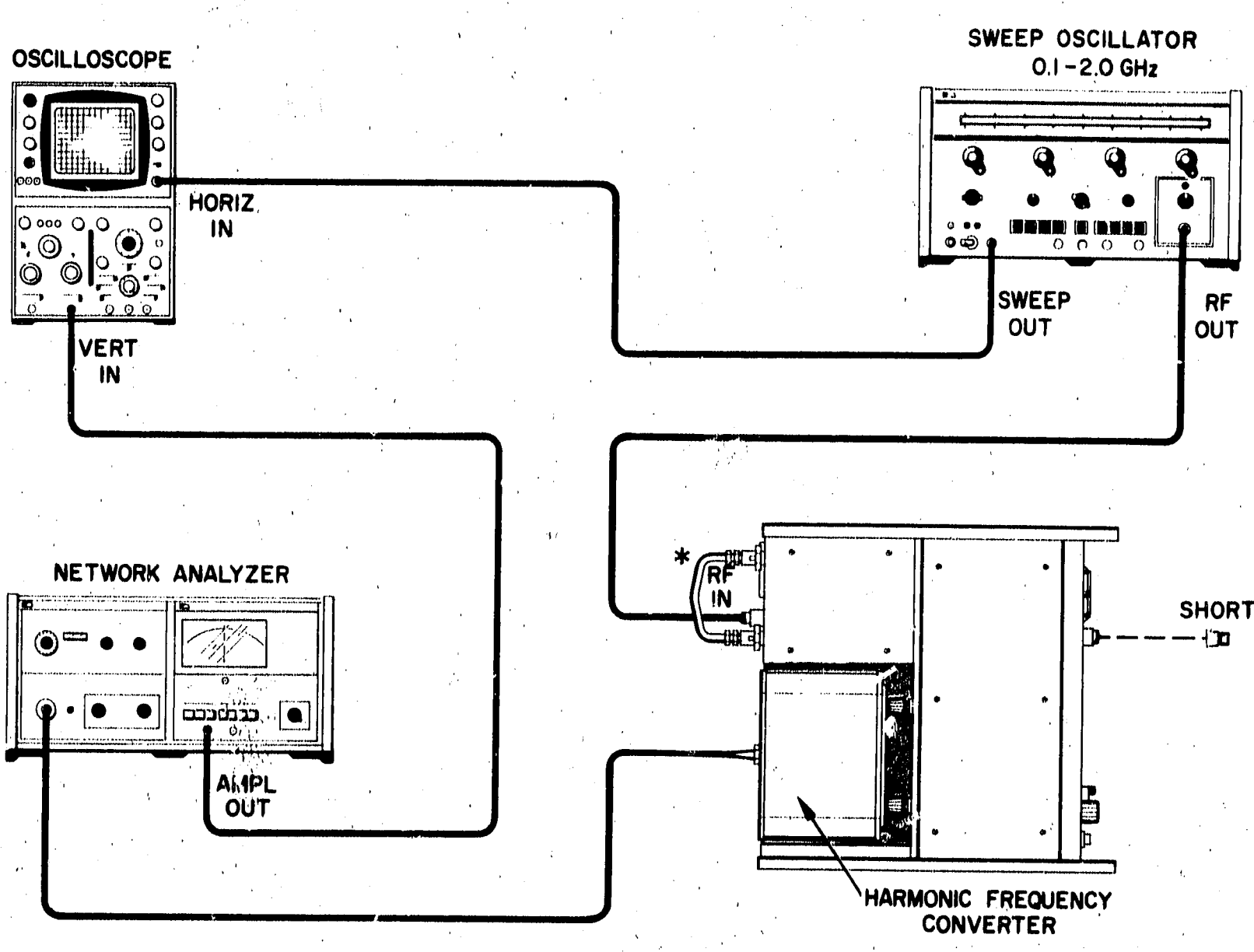
Test Number	Specification Tested	Limits	Indication Measured	
1	Directivity (Equivalent Reflection Coefficient)	> 36 dB (< 0.016)	<u>INPUT PORT A</u>	
			_____ 0.1 to _____ GHz.	
			_____ to _____ GHz.	
			_____ to 1.0 GHz.	
		> 32 dB (< 0.025)	_____ 1.0 to 2.0 GHz.	
			<u>INPUT PORT B</u>	
			_____ 0.1 to _____ GHz.	
			_____ to _____ GHz.	
2	Load Match Reflection Coefficient (VSWR)	< 0.1 (< 1.22)	<u>INPUT PORT A</u>	
			_____ 0.1 to 0.2 GHz.	
			_____ 0.2 to _____ GHz.	
			_____ 0.2 to _____ GHz.	
		< 0.063 (< 1.13)	_____ to 2.0 GHz.	
			<u>INPUT PORT B</u>	
			_____ 0.1 to 0.2 GHz.	
			_____ 0.2 to _____ GHz.	
3	Source Match Reflection Coefficient (VSWR)	< 0.057 (< 1.12)	<u>INPUT PORT A</u>	
			_____ 0.1 to _____ GHz.	
			_____ to _____ GHz.	
			_____ to 1.0 GHz.	
		< 0.057 (< 1.12)	_____ 1.0 to 2.0 GHz.	
			<u>INPUT PORT B</u>	
			_____ 0.1 to 0.2 GHz.	
			_____ 0.2 to _____ GHz.	
			_____ to _____ GHz.	
			_____ to 2.0 GHz.	

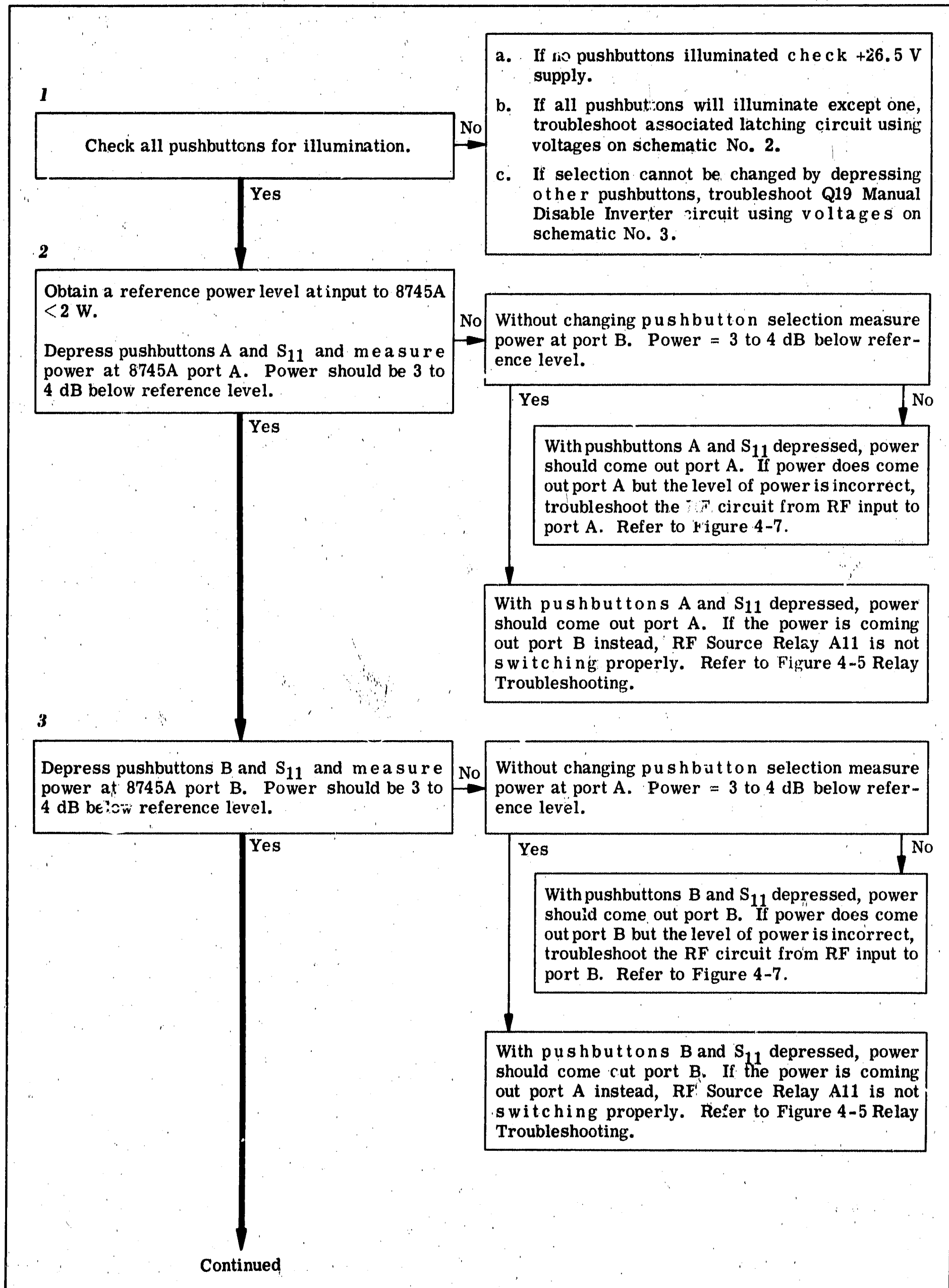

Figure 4-4. General Troubleshooting (Sheet 1 of 2)

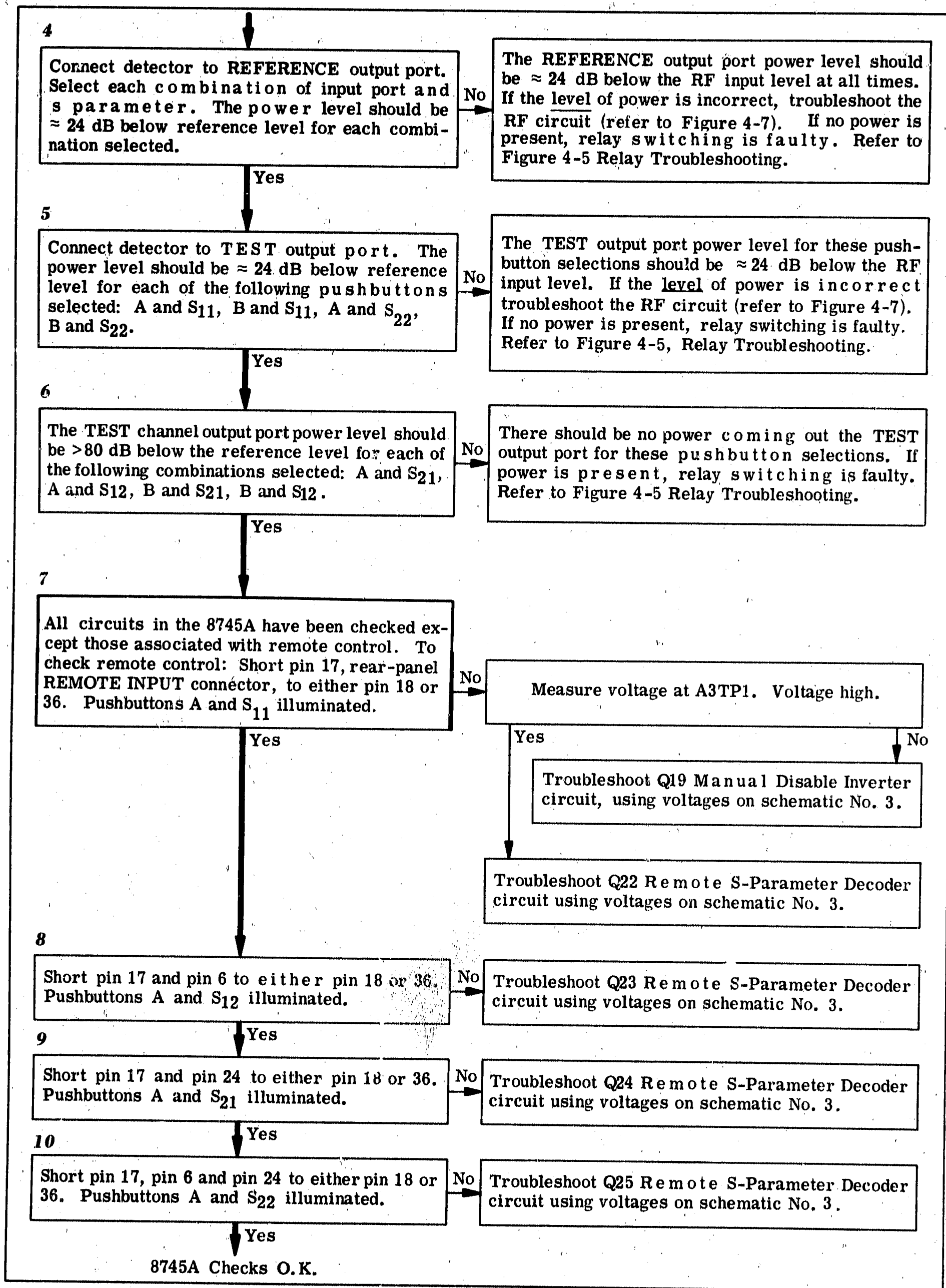

Figure 4-4. General Troubleshooting (Sheet 2 of 2)

NOTE

All voltages taken with negative lead of voltmeter connected to A7TP2 (Test Relay WHT/BLK lead).

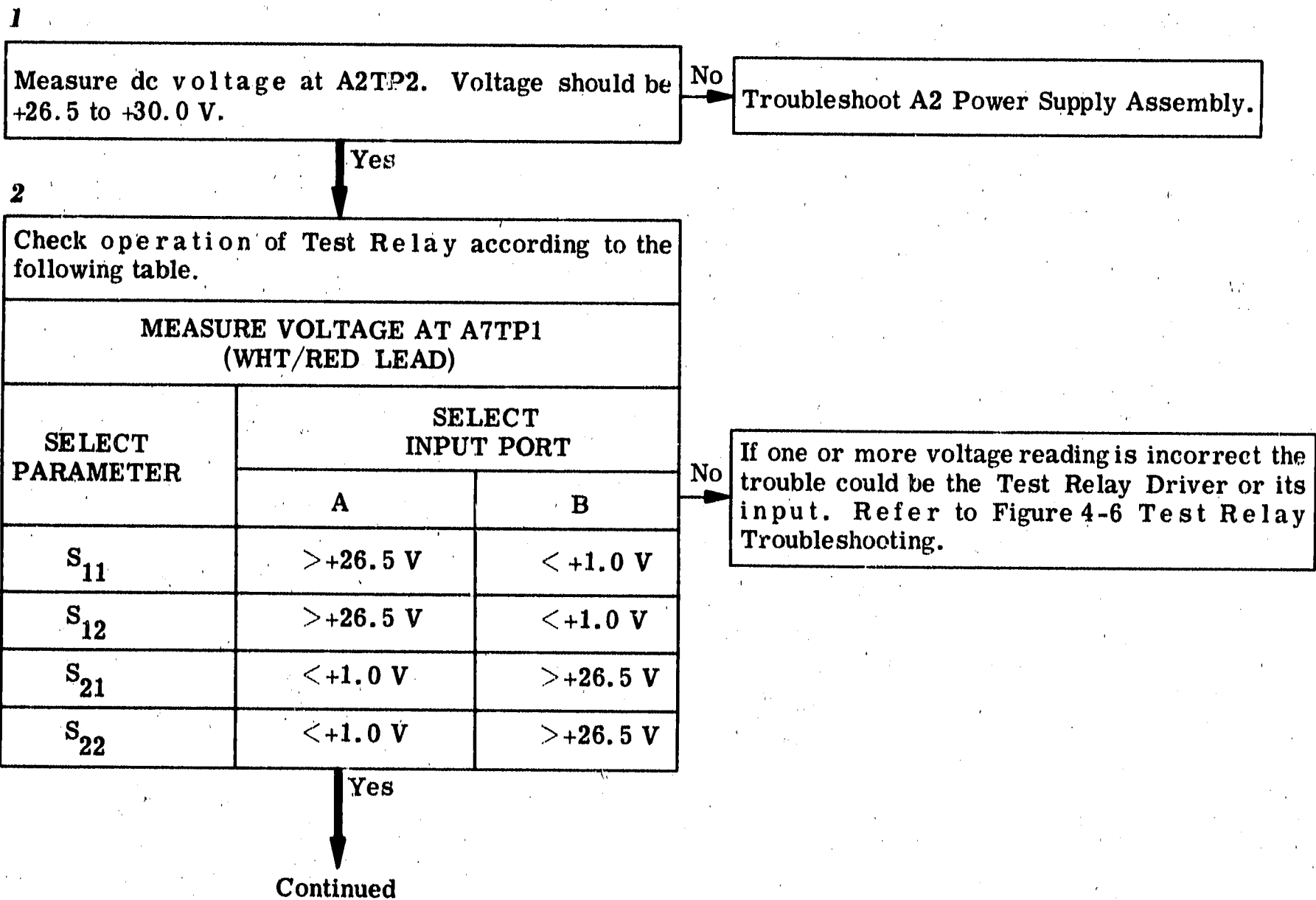

Figure 4-5. Relay Troubleshooting (Sheet 1 of 2)

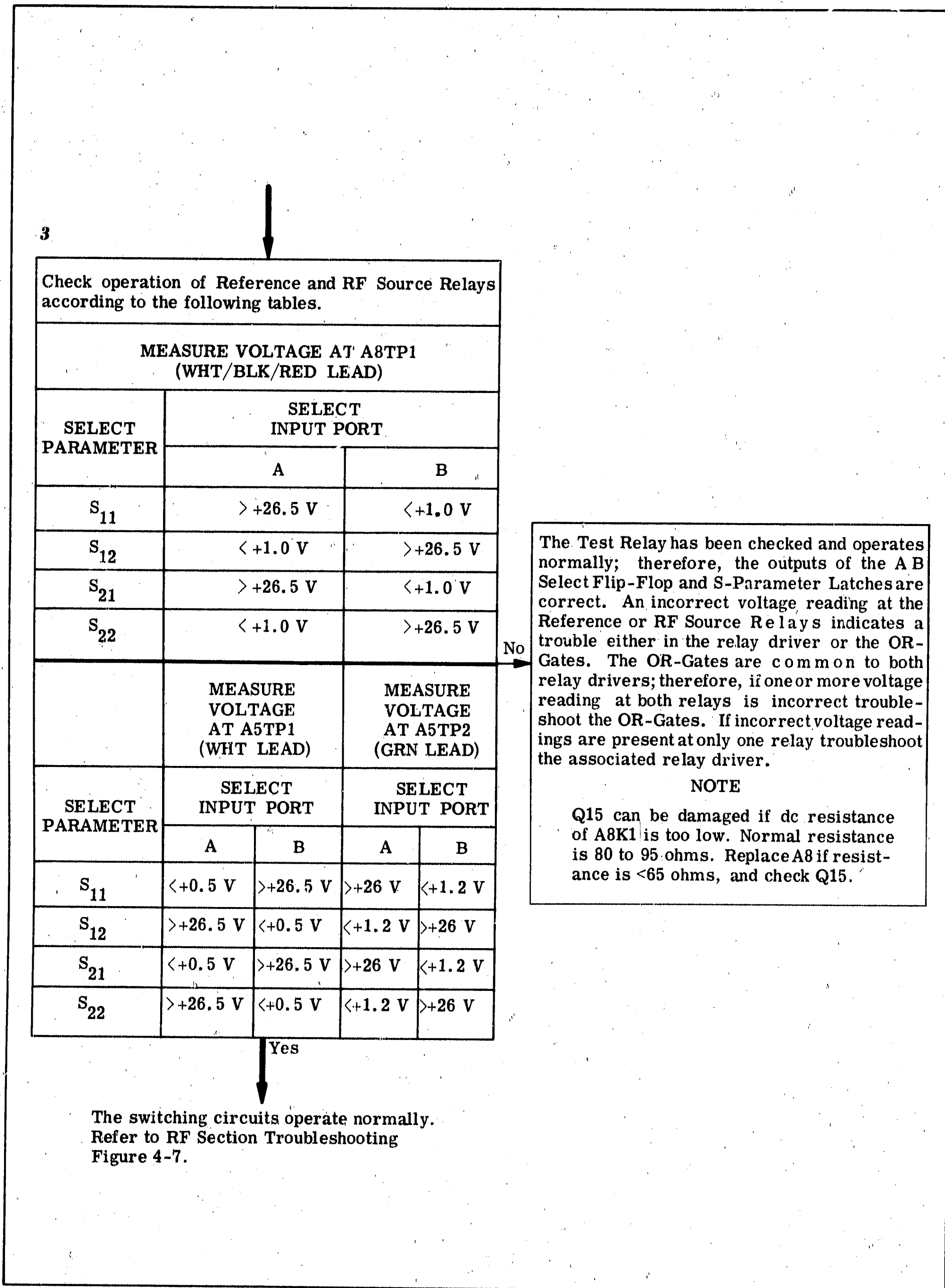

Figure 4-5. Relay Troubleshooting (Sheet 2 of 2)

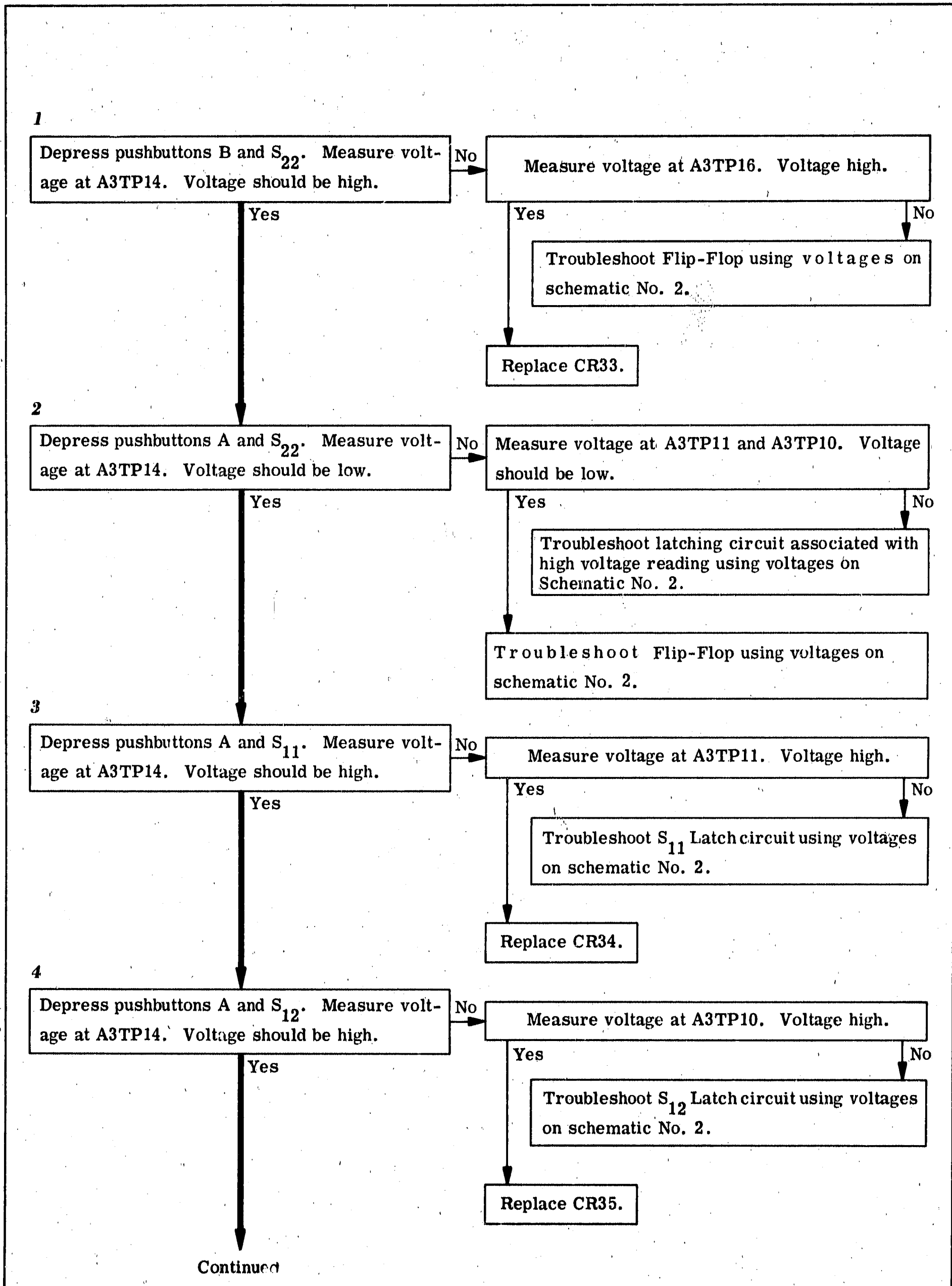

Figure 4-3. Test Relay Troubleshooting (Sheet 1 of 2)

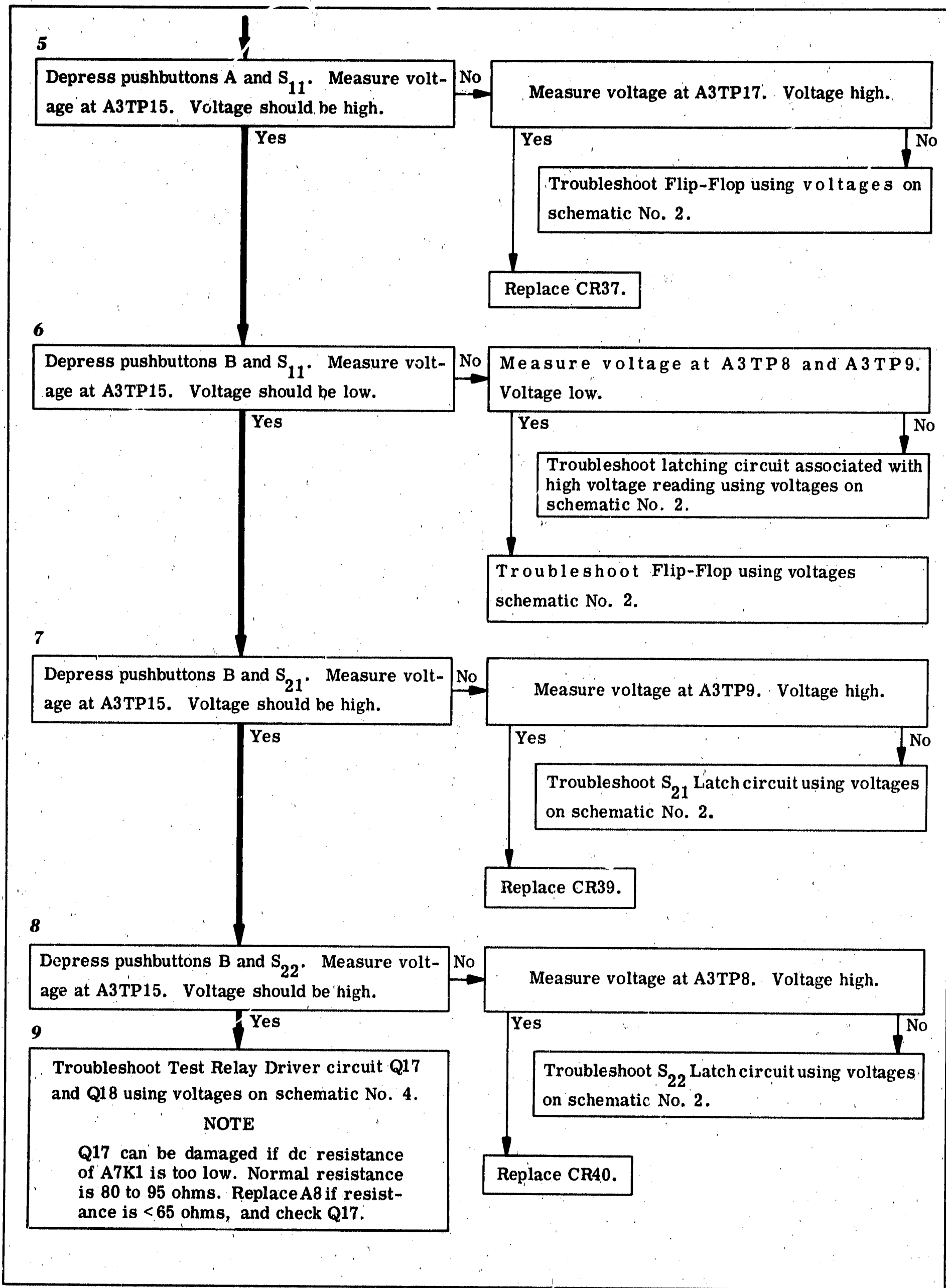

Figure 4-6. Test Relay Troubleshooting (Sheet 2 of 2)

RF SECTION TROUBLESHOOTING

To determine the trouble symptom perform the general troubleshooting procedure in Figure 4-4.

Isolating an RF trouble is best accomplished by using a HP Model 1415A Time Domain Reflectometer (TDR)*. The most probable causes of RF trouble are front-and-rear-panel coaxial connectors and the RF coaxial switches A7 through A11. Several symptoms are listed below with procedures to help locate the trouble.

SYMPTOM. Power level at INPUT PORT A abnormal.

PROCEDURE.

1. Connect a 50-ohm termination to the 8745A RF INPUT port.
2. Ground the bias filter capacitors by connecting a jumper wire from the bias input at A9 to chassis ground (violet wire at A5 Assy).
3. Connect TDR to INPUT PORT A.
4. Depress pushbuttons A and S₁₁.
5. Waveform "A" is a typical TDR presentation of a working unit.
6. If coaxial switch A9 is in the wrong position the TDR presentation will be similar to waveform "B" (line terminated in A9's blocking capacitor and 50-ohm load; can be simulated by switching from A and S₁₁ to B and S₁₁).
7. If A9 is not making contact the TDR presentation will indicate an open as shown in waveform "C".
8. If A11 is open or switched to the opposite port the TDR presentation will be similar to waveform "D".
9. The trouble may be in a coaxial switch or in the associated coaxial cable. Before replacing a suspected coaxial switch, remove the associated coaxial cable and check it separately.

SYMPTOM. Power level at INPUT PORT B abnormal.

PROCEDURE.

1. Connect a 50-ohm termination to the 8745A RF INPUT port.
2. Ground the bias filter capacitors by connecting a jumper wire from the bias input at A10 to chassis ground (violet wire at A5 Assy).
3. Connect TDR to INPUT PORT B.
4. Depress pushbuttons B and S₁₁.
5. Waveform "A" is a typical TDR presentation of a working unit.
6. If coaxial switch A10 is in the wrong position the TDR presentation will be similar to waveform "B" (line terminated in A10's blocking

capacitor and 50-ohm load; can be simulated by switching from B and S₁₁ to A and S₁₁).

7. If A10 is not making contact the TDR presentation will indicate an open as shown in waveform "C".
8. If A11 is open or switched to the opposite port the TDR presentation will be similar to waveform "D".
9. The trouble may be in a coaxial switch or in the associated coaxial cable. Before replacing a suspected coaxial switch, remove the associated coaxial cable and check it separately.

SYMPTOM. Power level at REFERENCE or TEST channel output port abnormal.

PROCEDURE.

1. Disconnect RF input from signal source.
2. Connect TDR to the REFERENCE or TEST output port.
3. Waveform "E" is a typical TDR presentation looking into the REFERENCE or TEST channel connector.
4. In normal operation A7 and A8 connect an output port to the coupled arm of a directional coupler regardless of the combination of pushbuttons selected; therefore, to determine if A7 or A8 is switching properly, switch between pushbuttons A and B, which should terminate the switch into the coupled arm of one coupler and then the other. Observe the TDR presentation closely. It is unlikely that the presentation looking at both couplers will be identical; therefore, if the presentation doesn't change, the coaxial switch is probably not switching. Remove the suspected switch and, as a further check, measure dc continuity through the switch's center conductor while applying a 24V switching voltage from a power supply.
5. If A7 or A8 is open or shorted the TDR presentation will show an open or a short at the input or output of the switch. The open or short may be the coaxial cable connector. Remove the coaxial cable and check the cable separately.

*Connect a 20-cm air line (HP 11567A) at the end of the TDR cable to obtain a 50-ohm reference on CRT display.

Figure 4-7. RF Section Troubleshooting (Sheet 1 of 2)

RF SECTION TROUBLESHOOTING (Contd)

TDR DISPLAYS

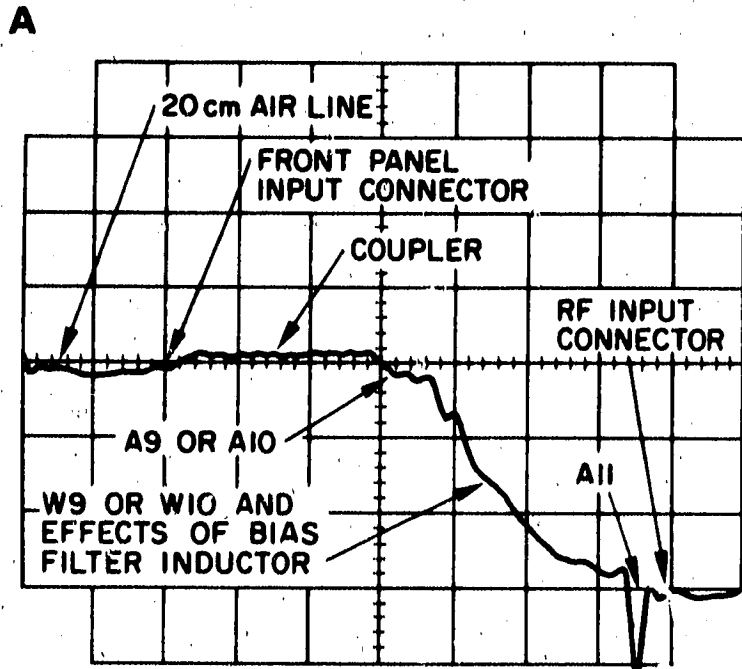

Normal Display looking into INPUT PORT A or INPUT PORT B with RF INPUT terminated in 50 Ω and Bias Input shorted to chassis.

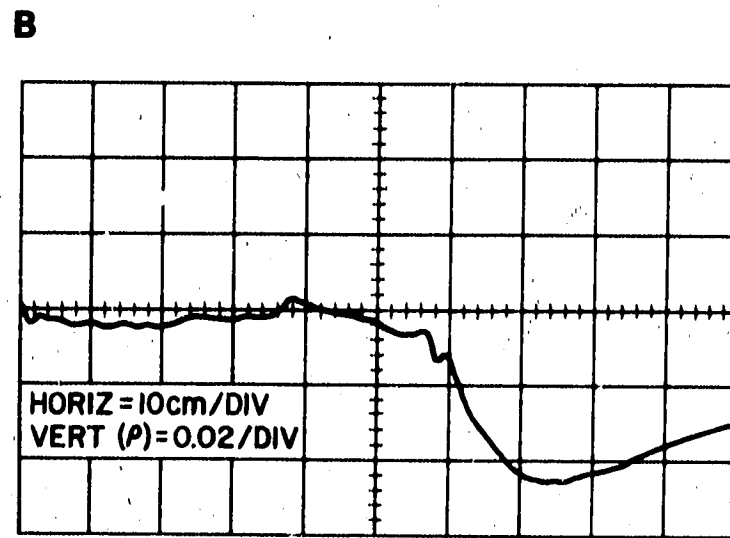

Normal Display looking into INPUT PORT A or INPUT PORT B with A9 or A10 switched to its termination

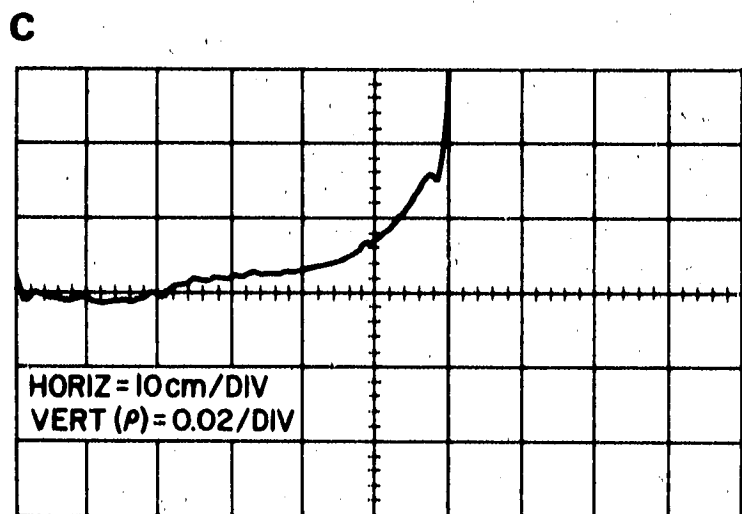

Looking into INPUT PORT A or INPUT PORT B with output connector of A9 or A10 open.

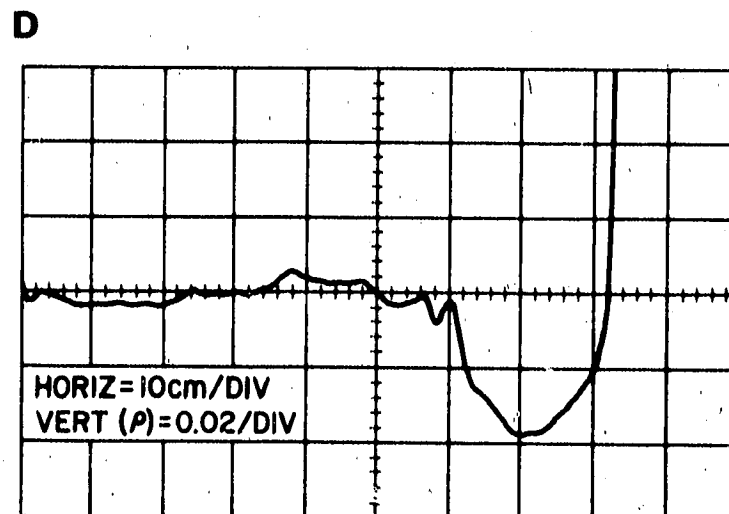

Looking into INPUT PORT A or INPUT PORT B with A11 switched to the opposite Port.

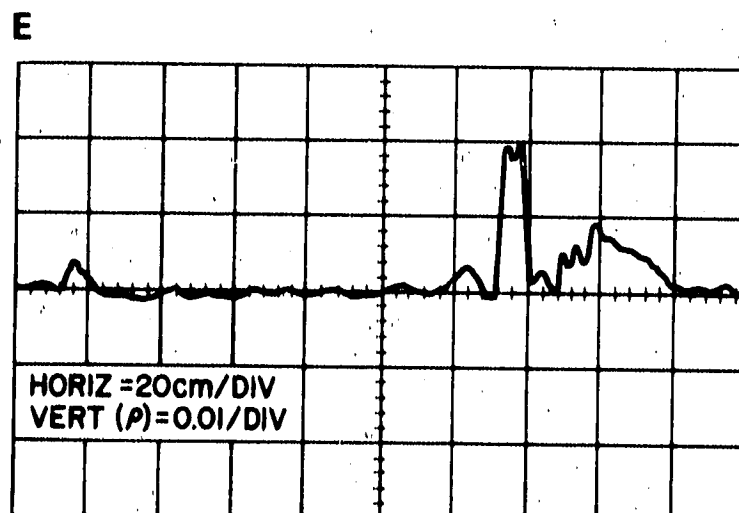

Normal Display looking into REFERENCE or TEST Channel Output Port.

Figure 4-7. RF Section Troubleshooting (Sheet 2 of 2)

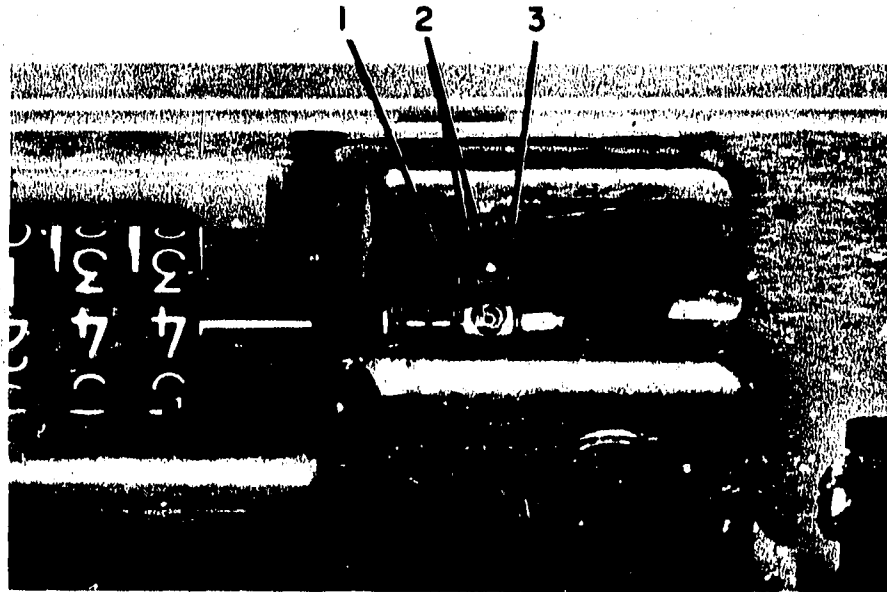
**FRICION CLUTCH ADJUSTMENT:**

1. Remove the 8745A top cover.
2. Loosen the two hollow hex-head screws (2) holding the collar (1) in position on the shaft.
3. Hold the collar tightly against the spring washer (3) flattening the washer, while tightening the hollow hex-head screws (2).
4. Check the operation of the clutch as follows:
 - a. Adjust the REFERENCE PLANE EXTENSION crank until counter reads all zeros.
 - b. Hold thumbwheel to retain zero indication and rotate the crank counterclockwise until the stop is reached. Release the thumbwheel.
 - c. Rotate the crank clockwise until the stop is reached. The dial should indicate 15 cm or greater.
 - d. Rotate the crank counterclockwise until the stop is reached. The counter dial should indicate all zeros again. If the dial does not indicate all zeros, readjust the friction clutch and repeat this check.

Figure 4-8. Digital Counter Friction Clutch Adjustment

PARTS LIST

SECTION V REPLACEABLE PARTS

5-1. INTRODUCTION.

5-2. This section contains information for ordering replacement parts. Table 5-1 lists parts in alpha-numerical order of their reference designations and includes the description and HP part number of each part, together with any applicable notes. Table 5-2 lists parts in order of their HP part number and provides the following information on each part:

- a. Description of the part (see list of abbreviations below).
- b. Typical manufacturer of the part in a five-digit code; see list of manufacturers in Table 5-3.
- c. Manufacturer's part number.
- d. Total quantity used in the instrument (TQ column).

5-3. Miscellaneous parts are listed at the end of Table 5-1.

5-4. ORDERING INFORMATION.

5-5. To obtain replacement parts, address order or inquiry to your local Hewlett-Packard sales and service office (see list at rear of this manual). Identify parts by Hewlett-Packard part number.

5-6. To obtain a part not listed, include:

- a. Instrument model number.
- b. Instrument serial number.
- c. Description of part.
- d. Function and location of part.

REFERENCE DESIGNATORS			
<p>A = assembly B = motor BT = battery C = capacitor CP = coupler CR = diode DL = delay line DS = device signaling (lamp) E = misc electronic part</p>	<p>F = fuse FL = filter IC = integrated circuit J = jack K = relay L = inductor LS = loud speaker M = meter MK = microphone</p>	<p>MP = mechanical part P = plug Q = transistor R = resistor RT = thermistor S = switch T = transformer TB = terminal board TP = test point</p>	<p>U = integrated circuit V = vacuum, tube, neon bulb, photocell, etc. VR = voltage regulator W = cable X = socket Y = crystal Z = tuned cavity, network</p>
ABBREVIATIONS			
<p>A = amperes AFC = automatic frequency control AMPL = amplifier BFO = beat frequency oscillator BE CU = beryllium copper BH = binder head BP = bandpass BRS = brass BWO = backward wave oscillator CCW = counter-clockwise CER = ceramic CMO = cabinet mount only COEF = coefficient COM = common COMP = composition COMPL = complete CCNN = connector CP = cadmium plate CRT = cathode-ray tube CW = clockwise DEPC = deposited carbon DR = drive ELECT = electrolytic ENCAP = encapsulated EXT = external F = farads FH = flat head FIL H = fillister head FXD = fixed G = giga (10⁹) GE = germanium GL = glass GRD = ground(ed)</p>	<p>H = henries HDW = hardware HEX = hexagonal HG = mercury HR = hour(s) HZ = hertz IF = intermediate freq IMPG = impregnated INCD = incandescent INCL = include(s) INS = insulation(ed) INT = internal K = kilo = 1000 LH = left hand LIN = linear taper LK WASH = lock washer LOG = logarithmic taper LPF = low pass filter M = milli = 10⁻³ MEG = meg = 10⁶ MET FLM = metal film MET OX = metallic oxide MFR = manufacturer MHZ = mega hertz MINAT = miniature MOM = momentary MOS = metal oxide substrate MTG = mounting MY = "mylar" N = nano (10⁻⁹) N/C = normally closed NE = neon NI PL = nickel plate</p>	<p>N/O = normally open NOM = nominal NPO = negative positive zero (zero temperature coefficient) NPN = negative-positive-negative NRFR = not recommended for field replacement NSR = not separately replaceable OBD = order by description OH = oval head OX = oxide P = peak PC = printed circuit PF = picofarads = 10⁻¹² farads PH BRZ = phosphor bronze PHL = Phillips PIV = peak inverse voltage PNP = positive-negative-positive P/O = part of POLY = polystyrene PORC = porcelain POS = position(s) POT = potentiometer PP = peak-to-peak PT = point PWV = peak working voltage RECT = rectifier RF = radio frequency RH = round head or right hand</p>	<p>RMO = rack mount only RMS = root-mean square RWV = reverse working voltage S-B = slow-blow SCR = screw SE = selenium SECT = section(s) SEMICON = semiconductor SI = silicon SIL = silver SL = slide SPG = spring SPL = special SST = stainless steel SR = split ring STL = steel TA = tantalum TD = time delay TGL = toggle THD = thread TI = titanium TOL = tolerance TRIM = trimmer TWT = traveling wave tube U = micro = 10⁻⁶ VAR = variable VDCW = dc working volts W/ = with W = watts WIV = working inverse voltage WW = wirewound W/O = without</p>

Table 5-1. Reference Designation Index

Reference Designation	Part No.	Description #	Note
A1	08745-6058	ASSY:S-PARAMETER SWITCH	
A1DS1	2140-0300	LAMP:INCANDESCENT 18V 0.04A	
A1DS2	2140-0300	LAMP:INCANDESCENT 18V 0.04A	
A1DS3	2140-0300	LAMP:INCANDESCENT 18V 0.04A	
A1DS4	2140-0300	LAMP:INCANDESCENT 18V 0.04A	
A1DS5	2140-0300	LAMP:INCANDESCENT 18V 0.04A	
A1DS6	2140-0300	LAMP:INCANDESCENT 18V 0.04A	
A1S1		NOT SEPARATELY REPLACEABLE	
A1S2		NOT SEPARATELY REPLACEABLE	
A1S3		NOT SEPARATELY REPLACEABLE	
A1S4		NOT SEPARATELY REPLACEABLE	
A1S5		NOT SEPARATELY REPLACEABLE	
A1S6		NOT SEPARATELY REPLACEABLE	
A2	08745-6056	ASSY:POWER SUPPLY	
A2C1	0180-0097	C:FXD ELECT 47UF 10% 35VDCW	
A2CR1	1901-0049	DIODE:SILICON 50PIV	
A2CR2	1901-0049	DIODE:SILICON 50PIV	
A2CR3	1901-0049	DIODE:SILICON 50PIV	
A2CR4	1901-0049	DIODE:SILICON 50PIV	
A2CR5	1902-3193	DIODE BREAKDOWN:13.3V 5%	
A2Q1		NOT ASSIGNED	
A2Q2	1854-0039	TRANSISTOR:SILICON 2N3053	
A2Q3	1854-0071	TRANSISTOR:SILICON NPN	
A2Q4	1854-0071	TRANSISTOR:SILICON NPN	
A2R1	0764-0016	R:FXD MET FLM 1000 OHM 5% 2W	
A2R2	0811-1666	R:FXD WW 1.0 OHM 5% 2W	
A2R3	0757-0280	R:FXD MET FLM 1K OHM 1% 1/8W	
A2R4	0698-3136	R:FXD MET FLM 17.8K OHM 1% 1/8W	
A2R5	0757-0278	R:FXD MET FLM 1.78K OHM 1% 1/8W	
A2R6	0757-0438	R:FXD MET FLM 5.11K OHM 1% 1/8W	
A2R7	0757-0438	R:FXD MET FLM 5.11K OHM 1% 1/8W	
A3	08745-6053	ASSY:RELAY DRIVE	
A3C1 THRU	0150-0093	C:FXD CER 0.01 UF +80-20% 100VDCW	
A3C4	0150-0093	C:FXD CER 0.01 UF +80-20% 100VDCW	
A3CR1	1901-0044	DIODE:SILICON 20MA/1V	
A3CR2	1902-0679	DIODE BREAKDOWN:17.4V 5%	
A3CR3 THRU	1901-0044	DIODE:SILICON 20MA/1V	
A3CR5	1901-0044	DIODE:SILICON 20MA/1V	

See introduction to this section for ordering information

Table 5-1. Reference Designation Index (Contd)

Reference Designation	Part No.	Description #	Note
A3CR6	1902-0679	DIODE BREAKDOWN: 17.4V 5%	
A3CR7	1901-0044	DIODE: SILICON 20MA/1V	
A3CR8	1901-0044	DIODE: SILICON 20MA/1V	
A3CR9	1901-0044	DIODE: SILICON 20MA/1V	
A3CR10	1902-0679	DIODE BREAKDOWN: 17.4V 5%	
A3CR11	1901-0044	DIODE: SILICON 20MA/1V	
A3CR12	1901-0044	DIODE: SILICON 20MA/1V	
A3CR13	1901-0044	DIODE: SILICON 20MA/1V	
A3CR14	1902-0679	DIODE BREAKDOWN: 17.4V 5%	
A3CR15	1901-0044	DIODE: SILICON 20MA/1V	
A3CR16	1901-0044	DIODE: SILICON 20MA/1V	
A3CR17	1901-0044	DIODE: SILICON 20MA/1V	
A3CR18	1901-0044	DIODE: SILICON 20MA/1V	
A3CR19	1901-0044	DIODE: SILICON 20MA/1V	
A3CR20	1901-0044	DIODE: SILICON 20MA/1V	
A3CR21	1901-0044	DIODE: SILICON 20MA/1V	
A3CR22	1901-0044	DIODE: SILICON 20MA/1V	
A3CR23	1901-0044	DIODE: SILICON 20MA/1V	
A3CR24	1901-0044	DIODE: SILICON 20MA/1V	
A3CR25	1901-0044	DIODE: SILICON 20MA/1V	
A3CR26	1901-0044	DIODE: SILICON 20MA/1V	
A3CR27	1901-0044	DIODE: SILICON 20MA/1V	
A3CR28	1901-0044	DIODE: SILICON 20MA/1V	
A3CR29	1901-0044	DIODE: SILICON 20MA/1V	
A3CR30	1901-0044	DIODE: SILICON 20MA/1V	
A3CR31	1901-0044	DIODE: SILICON 20MA/1V	
A3CR32	1901-0044	DIODE: SILICON 20MA/1V	
A3CR33	1901-0044	DIODE: SILICON 20MA/1V	
A3CR34	1901-0044	DIODE: SILICON 20MA/1V	
A3CR35	1901-0044	DIODE: SILICON 20MA/1V	
A3CR36	1901-0044	DIODE: SILICON 20MA/1V	
A3CR37	1901-0044	DIODE: SILICON 20MA/1V	
A3CR38	1901-0044	DIODE: SILICON 20MA/1V	
A3CR39	1901-0044	DIODE: SILICON 20MA/1V	
A3CR40	1901-0044	DIODE: SILICON 20MA/1V	
A3CR41	1902-0041	DIODE: BREAKDOWN 5.11V 5% 400MW	
A3CR42	1901-0049	DIODE: SILICON 50PIV	
A3CR43	1901-0044	DIODE: SILICON 20MA/1V	
A3CR44	1901-0044	DIODE: SILICON 20MA/1V	
A3CR45	1902-0041	DIODE: BREAKDOWN 5.11V 5% 400MW	
A3CR46	1901-0049	DIODE: SILICON 50PIV	
A3CR47	1901-0044	DIODE: SILICON 20MA/1V	
A3CR48	1901-0044	DIODE: SILICON 20MA/1V	
A3CR49	1901-0044	DIODE: SILICON 20MA/1V	
A3CR50	1901-0044	DIODE: SILICON 20MA/1V	
A3CR51	1901-0044	DIODE: SILICON 20MA/1V	
A3CR52	1901-0044	DIODE: SILICON 20MA/1V	
A3CR53	1901-0044	DIODE: SILICON 20MA/1V	
A3CR54	1901-0044	DIODE: SILICON 20MA/1V	

See introduction to this section for ordering information

Table 5-1. Reference Designation Index (Contd)

Reference Designation	Part No.	Description #	Note
A3CR55	1902-3290	DIODE BREAKDOWN:SILICON 31.6V 5%	
A3CR56	1901-0049	DIODE:SILICON 50PIV	
A3CR57	1901-0049	DIODE:SILICON 50PIV	
A3CR58	1902-3290	DIODE BREAKDOWN:SILICON 31.6V 5%	
A3Q1	1853-0020	TRANSISTOR:SILICON PNP	
A3Q2	1854-0071	TRANSISTOR:SILICON NPN	
A3Q3	1853-0020	TRANSISTOR:SILICON PNP	
A3Q4	1854-0071	TRANSISTOR:SILICON NPN	
A3Q5	1853-0020	TRANSISTOR:SILICON PNP	
A3Q6	1854-0071	TRANSISTOR:SILICON NPN	
A3Q7	1854-0071	TRANSISTOR:SILICON NPN	
A3Q8	1854-0071	TRANSISTOR:SILICON NPN	
A3Q9	1853-0020	TRANSISTOR:SILICON PNP	
A3Q10	1853-0020	TRANSISTOR:SILICON PNP	
A3Q11	1854-0039	TRANSISTOR:SILICON 2N3053	
A3Q12	1853-0027	TRANSISTOR:SILICON PNP	
A3Q13	1854-0039	TRANSISTOR:SILICON 2N3053	
A3Q14	1853-0027	TRANSISTOR:SILICON PNP	
A3Q15	1853-0027	TRANSISTOR:SILICON PNP	
A3Q16	1854-0071	TRANSISTOR:SILICON NPN	
A3Q17	1853-0027	TRANSISTOR:SILICON PNP	
A3Q18	1854-0071	TRANSISTOR:SILICON NPN	
A3Q19	1854-0071	TRANSISTOR:SILICON NPN	
A3Q20	1854-0071	TRANSISTOR:SILICON NPN	
A3Q21	1854-0071	TRANSISTOR:SILICON NPN	
A3Q22	1854-0071	TRANSISTOR:SILICON NPN	
A3Q23	1854-0071	TRANSISTOR:SILICON NPN	
A3Q24	1854-0071	TRANSISTOR:SILICON NPN	
A3Q25	1854-0071	TRANSISTOR:SILICON NPN	
A3Q26	1854-0071	TRANSISTOR:SILICON NPN	
A3Q27	1854-0071	TRANSISTOR:SILICON NPN	
A3R1	0757-0442	R:FXD MET FLM 10.0K OHM 1% 1/8W	
A3R2	0698-0083	R:FXD MET FLM 1.96K OHM 1% 1/8W	
A3R3	0698-3155	R:FXD MET FLM 4.64K OHM 1% 1/8W	
A3R4	0758-0015	R:FXD MET OX 220 OHM 5% 1/2W	
A3R5	0698-0083	R:FXD MET FLM 1.96K OHM 1% 1/8W	
A3R6	0698-3155	R:FXD MET FLM 4.64K OHM 1% 1/8W	
A3R7	0758-0015	R:FXD MET OX 220 OHM 5% 1/2W	
A3R8	0698-0083	R:FXD MET FLM 1.96K OHM 1% 1/8W	
A3R9	0698-3155	R:FXD MET FLM 4.64K OHM 1% 1/8W	
A3R10	0758-0015	R:FXD MET OX 220 OHM 5% 1/2W	
A3R11	0698-0083	R:FXD MET FLM 1.96K OHM 1% 1/8W	
A3R12	0698-3155	R:FXD MET FLM 4.64K OHM 1% 1/8W	
A3R13	0758-0015	R:FXD MET OX 220 OHM 5% 1/2W	
A3R14	0758-0043	R:FXD MET OX 1800 OHM 5% 1/2W	
A3R15	0758-0015	R:FXD MET OX 220 OHM 5% 1/2W	

See introduction to this section for ordering information

Table 5-1. Reference Designation Index (Contd)

Reference Designation	Part No.	Description #	Note
A3R16	0757-0438	R:FXD MET FLM 5.11K OHM 1% 1/8W	
A3R17	0757-0438	R:FXD MET FLM 5.11K OHM 1% 1/8W	
A3R18	0758-0015	R:FXD MET OX 220 OHM 5% 1/2W	
A3R19	0758-0043	R:FXD MET OX 1800 OHM 5% 1/2W	
A3R20	0698-0083	R:FXD MET FLM 1.96K OHM 1% 1/8W	
A3R21	0698-0083	R:FXD MET FLM 1.96K OHM 1% 1/8W	
A3R22	0757-0442	R:FXD MET FLM 10.0K OHM 1% 1/8W	
A3R23	0758-0004	R:FXD MET OX 2700 OHM 5% 1/2W	
A3R24	0757-0442	R:FXD MET FLM 10.0K OHM 1% 1/8W	
A3R25	0757-0438	R:FXD MET FLM 5.11K OHM 1% 1/8W	
A3R26	0757-0279	R:FXD MET FLM 3.16K OHM 1% 1/8W	
A3R27	0698-0083	R:FXD MET FLM 1.96K OHM 1% 1/8W	
A3R28	0758-0004	R:FXD MET OX 2700 OHM 5% 1/2W	
A3R29	0757-0442	R:FXD MET FLM 10.0K OHM 1% 1/8W	
A3R30	0757-0442	R:FXD MET FLM 10.0K OHM 1% 1/8W	
A3R31	0698-3150	R:FXD MET FLM 2.37K OHM 1% 1/8W	
A3R32	0698-3154	R:FXD MET FLM 4.22K OHM 1% 1/8W	
A3R33	0758-0004	R:FXD MET OX 2700 OHM 5% 1/2W	
A3R34	0757-0442	R:FXD MET FLM 10.0K OHM 1% 1/8W	
A3R35	0757-0442	R:FXD MET FLM 10.0K OHM 1% 1/8W	
A3R36	0698-3150	R:FXD MET FLM 2.37K OHM 1% 1/8W	
A3R37	0698-3154	R:FXD MET FLM 4.22K OHM 1% 1/8W	
A3R38	0757-0199	R:FXD MET FLM 21.5K OHM 1% 1/8W	
A3R39	0757-0442	R:FXD MET FLM 10.0K OHM 1% 1/8W	
A3R40	0698-3156	R:FXD MET FLM 14.7K OHM 1% 1/8W	
A3R41	0698-3154	R:FXD MET FLM 4.22K OHM 1% 1/8W	
A3R42	0757-0199	R:FXD MET FLM 21.5K OHM 1% 1/8W	
A3R43	0757-0442	R:FXD MET FLM 10.0K OHM 1% 1/8W	
A3R44	0698-3156	R:FXD MET FLM 14.7K OHM 1% 1/8W	
A3R45	0698-3154	R:FXD MET FLM 4.22K OHM 1% 1/8W	
A3R46	0757-0199	R:FXD MET FLM 21.5K OHM 1% 1/8W	
A3R47	0757-0442	R:FXD MET FLM 10.0K OHM 1% 1/8W	
A3R48	0698-3156	R:FXD MET FLM 14.7K OHM 1% 1/8W	
A3R49	0698-3154	R:FXD MET FLM 4.22K OHM 1% 1/8W	
A3R50	0757-0199	R:FXD MET FLM 21.5K OHM 1% 1/8W	
A3R51	0757-0442	R:FXD MET FLM 10.0K OHM 1% 1/8W	
A3R52	0698-3156	R:FXD MET FLM 14.7K OHM 1% 1/8W	
A3R53	0698-3154	R:FXD MET FLM 4.22K OHM 1% 1/8W	
A3R54	0757-0438	R:FXD MET FLM 5.11K OHM 1% 1/8W	
A3R55	0757-0438	R:FXD MET FLM 5.11K OHM 1% 1/8W	
A3R56	0757-0462	R:FXD MET FLM 75.0K OHM 1% 1/8W	
A3R57	0698-0083	R:FXD MET FLM 1.96K OHM 1% 1/8W	
A3R58	0757-0438	R:FXD MET FLM 5.11K OHM 1% 1/8W	
A3R59	0758-0003	R:FXD MET OX 1000 OHM 5% 1/2W	
A3R60	0757-0460	R:FXD MET FLM 61.9K OHM 1% 1/8W	
A3R61	0698-3449	R:FXD MET FLM 28.7K OHM 1% 1/8W	
A3R62	0757-0442	R:FXD MET FLM 10.0K OHM 1% 1/8W	
A3R63	0757-0462	R:FXD MET FLM 75.0K OHM 1% 1/8W	
A3R64	0698-0083	R:FXD MET FLM 1.96K OHM 1% 1/8W	

See introduction to this section for ordering information

Table 5-1. Reference Designation Index (Contd)

Reference Designation	Part No.	Description #	Note
A3R65	0757-0438	R:FXD MET FLM 5.11K OHM 1% 1/8W	
A3R66	0758-0003	R:FXD MET OX 1000 OHM 5% 1/2W	
A3R67	0757-0460	R:FXD MET FLM 61.9K OHM 1% 1/8W	
A3R68	0698-3449	R:FXD MET FLM 28.7K OHM 1% 1/8W	
A3R69	0757-0442	R:FXD MET FLM 10.0K OHM 1% 1/8W	
A3R70	0757-0280	R:FXD MET FLM 1K OHM 1% 1/8W	
A3R71	0757-0280	R:FXD MET FLM 1K OHM 1% 1/8W	
A3R72	0757-0458	R:FXD MET FLM 51.1K OHM 1% 1/8W	
A3R73	0698-0083	R:FXD MET FLM 1.96K OHM 1% 1/8W	
A3R74	0758-0063	R:FXD MET OX 1600 OHM 5% 1/2W	
A3R75	0757-0200	R:FXD MET FLM 5.62K OHM 1% 1/8W	
A3R76	0698-3160	R:FXD MET FLM 31.6K OHM 1% 1/8W	
A3R77	0683-3615	R:FXD COMP 360 OHM 5% 1/4W	
A3R78	0698-0083	R:FXD MET FLM 1.96K OHM 1% 1/8W	
A3R79	0757-1078	R:FXD MET FLM 1.47K OHM 1% 1/2W	
A3R80	0757-0814	R:FXD MET FLM 511 OHM 1% 1/2W	
A3R81	0757-0458	R:FXD MET FLM 51.1K OHM 1% 1/8W	
A3R82	0698-0083	R:FXD MET FLM 1.96K OHM 1% 1/8W	
A3R83	0758-0034	R:FXD MET OX 2400 OHM 5% 1/2W	
A3R84	0758-0034	R:FXD MET OX 2400 OHM 5% 1/2W	
A3R85	0698-0083	R:FXD MET FLM 1.96K OHM 1% 1/8W	
A4	08745-6057	ASSY:INTERCONNECT	
A4XA2	1251-0213	CONNECTOR-PC 15 CONTACTS	
A4XA3	1251-1886	CONNECTOR:PC 30 CONTACTS	
A5	08745-6024	ASSY:BIAS FILTER	
A5C1	0180-2210	C:FXD AL ELECT 2 UF +50-10% 150VDCW	
A5C2	0180-2210	C:FXD AL ELECT 2 UF +50-10% 150VDCW	
A5C3	0180-2210	C:FXD AL ELECT 2 UF +50-10% 150VDCW	
A5C4	0180-2210	C:FXD AL ELECT 2 UF +50-10% 150VDCW	
A5R1	0683-1055	R:FXD COMP 1 MEGOHM 5% 1/4W	
A5R2	0683-1055	R:FXD COMP 1 MEGOHM 5% 1/4W	
A6	08745-6001	ASSY:LINE STRETCHER	
A7	3106-0005	SWITCH:COAXIAL SPDT 24V	
	08745-0039	BRACKET SUPPORT	
	08745-0041	BAR:CLAMPING	
A8	3106-0005	SWITCH:COAXIAL SPDT 24V	
	08745-0019	BRACKET:SUPPORT	
	08745-0042	BAR:CLAMPING	
A9	08745-6102	ASSY:RF SOURCE RELAY	
A10	08745-6102	ASSY:RF SOURCE RELAY	
A11	08745-6103	ASSY:INPUT RF SOURCE RELAY	
C1	0180-0369	C:FXD ELECT 2800 UF +75-10% 60VDCW	

See introduction to this section for ordering information

Table 5-1. Reference Designation Index (Contd)

Reference Designation	Part No.	Description #	Note
C2A C2B	0150-0119	C:FXD CER 2 X 0.01 UF 20% 250WVAC PART OF C2A	
DC1	08745-6009 08745-0040 08745-2055 08745-2054	DIRECTIONAL COUPLER(PAIR) SUPPORT BRACKET:REAR GUIDE:FRONT CLAMP EQUALIZER:REAR PART OF DC1	
DC2			
DS1	2140-0052	LAMP:GLOW	
F1	2110-0336 2110-0340	FUSE:CARTRIDGE 0.8 AMP 250V SLOW-BLOW(230V) FUSE:CARTRIDGE 0.4 AMP SLOW BLOW	
J1 J2 P1	1251-0085 1251-0148 1251-2261	CONNECTOR:FEMALE 36-PIN MINAT CONNECTOR:AC 3-PRONG MALE CONNECTOR:PC 15 PIN	
Q1	1854-0072	TRANSISTOR:SILICON NPN 2N3054	
	08745-0043 0340-0092 08745-0044 1200-0092	BRACKET:HEAT SINK (BLACK) INSULATOR:FEED-THRU BAR:CLAMPING BUSHING:TRANSISTOR	
R1	0683-4735	R:FXD COMP 47K OHM 5% 1/4W	
S1	3101-1248	SWITCH:PUSHBUTTON SPDT	
S2	3101-1234	SWITCH:SLIDE DPDT	
T1	9100-2728 0380-0719 08745-0037	TRANSFORMER:24.4V STANDOFF:8-32 TAP BRACKET:SUPPORT	
W1	8120-1348	CABLE ASSY:POWER CORD	
W2	08745-20062 5040-0273 08742-2022 08745-2047 08745-2038	ASSY:CABLE TEST OUT TO A7 INSULATOR:RF CONNECTOR PIN:FEMALE TERMINATOR:HYBRID ASSY:CABLE (REF OUT TO A6)	
W3			
W4 W5	5040-0273 08742-2022 08745-2047 08745-2035 08745-2036	INSULATOR:RF CONNECTOR PIN:FEMALE TERMINATOR:HYBRID ASSY:CABLE A7 TO DC1 CABLE ASSY A7 TO DC2	
W6 W7	08745-2035	NOT ASSIGNED CABLE ASSY A8 TO DC1	
W8 W9	08745-2036 08745-2034	CABLE ASSY:A8 TO DC2 CABLE ASSY:A9 TO A11	
W10 W11 W12 W13	08745-2033 08745-20060 08745-20064 08745-20063	CABLE ASSY:A10 TO A11 CABLE ASSY:A8 TO REAR PANEL CABLE ASSY:REAR PANEL COAXIAL LINK CABLE ASSY:REAR PANEL TO A6	
XF1	1400-0084	FUSEHOLDER:EXTRACTOR POST TYPE	

See introduction to this section for ordering information

Table 5-1. Reference Designation Index (Contd)

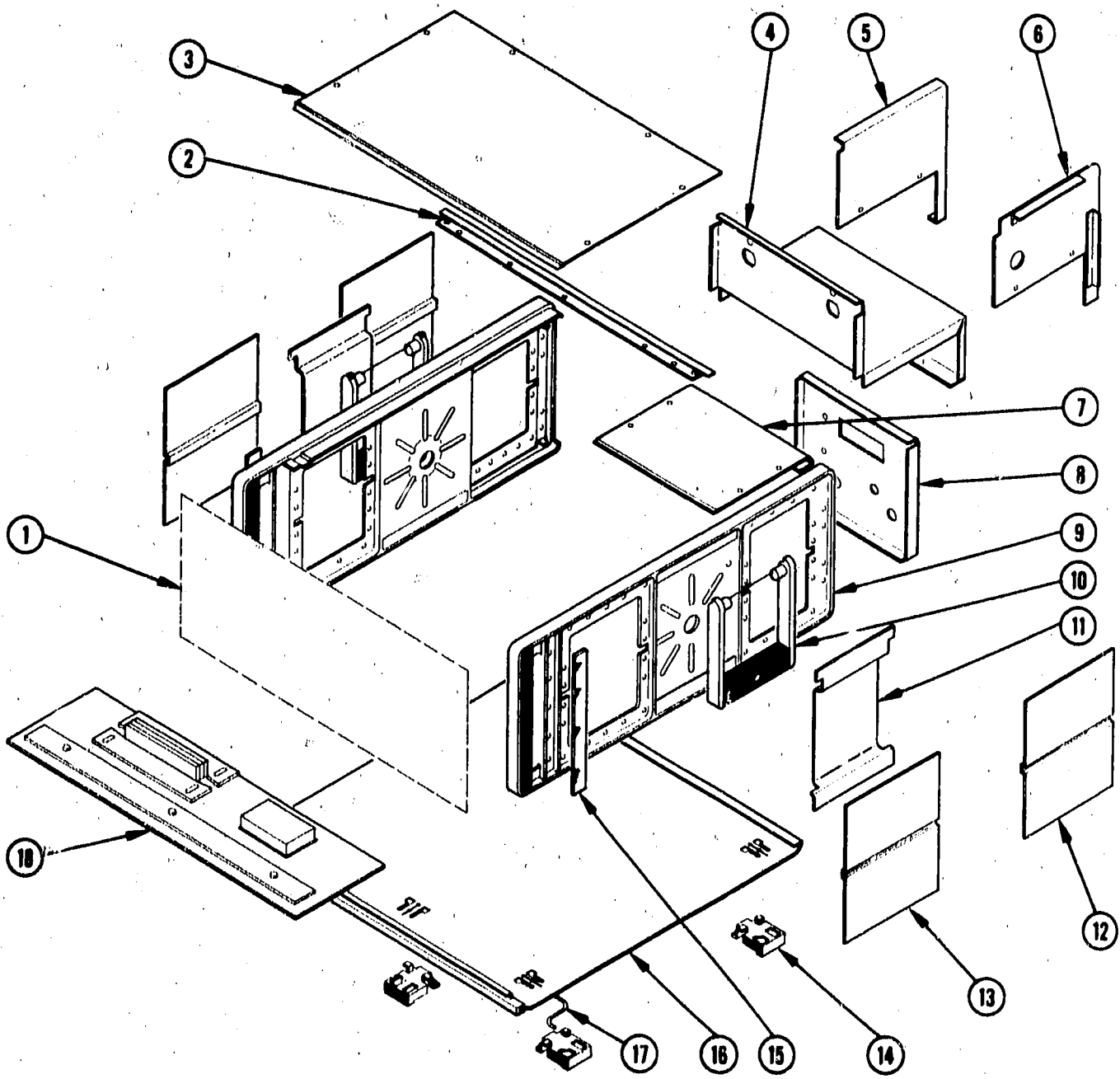
Reference Designation	Part No.	Description #	Note
			
<p>Figure 5-1. Cabinet Parts</p>			
1		REFER TO FIGURE 5-2 MODEL 8745A FRONT PANEL ASSY	
2	08745-2028	BRACE: TOP	
3	08745-0008	TOP COVER ASSY	
	2370-0013	SCREW: SST FLAT HD PHL DR 6-32 X 3/8"	
4	08745-00048	SUB-DECK	
5	08745-0018	FILLER PIECE SIDE FRAME	
6	08745-0016	FILLER PLATE	
7	08745-0013	COVER: TOP, REAR CORNER	
8	08745-00046	REAR PANEL (UNITS EQUIPPED W/COAXIAL LINK)	
	08745-0017	REAR PANEL (UNITS NOT EQUIPPED W/COAXIAL LINK)	
9	08745-2002	FRAME ASSY	
10	5060-0222	HANDLE ASSY	
11	5060-0766	RETAINER: HANDLE ASSY	
	2550-0016	SCREW: SST BH 8-32 X 5/16"	
12	5000-0098	REAR SIDE COVER (NON PERFORATED)	
	2370-0020	SCREW: SST FH PHL DR 6-32 X 3/16"	
13	5000-0099	FRONT SIDE COVER (PERFORATED)	
14	5060-0767	FOOT ASSY	
15	5000-0051	PLATE-FLUTED ALUMINUM	
16	08745-0009	BOTTOM COVER ASSY	
	2370-0013	SCREW: SST FLAT HD PHL DR 6-32 X 3/8"	
	6960-0002	PLUG HOLE: 0.5" DIA	
17	1490-0030	STAND: TILT	
18	5060-0775	KIT: RACK MOUNT	

See introduction to this section for ordering information

Table 5-1. Reference Designation Index (Contd)

Reference Designation	Part No.	Description #	Note
			
1	08745-2001	PANEL FRAME:TOP-BOTTOM	
2	08745-2020	TRIM:UPPER FRAME	
3	08745-2019	TRIM:LOWER FRAME	
4	0370-0766	END CAP:RIGHT	
5	0370-0767	PUSHBUTTON:SWITCH, GRAY	
6	0370-0802	LENS:PUSHBUTTON	
7	5000-6453	LABEL:PUSHBUTTON(B)	
	5000-6452	LABEL:PUSHBUTTON(A)	
	5000-6400	LABEL:PUSHBUTTON(S11)	
	5000-6401	LABEL:PUSHBUTTON(S12)	
	5000-6402	LABEL:PUSHBUTTON(S21)	
	5000-6403	LABEL:PUSHBUTTON(S22)	
8	0370-0765	END CAP:LEFT	
9	6960-0010	PLUG HOLE:0.625"DIA	
10	5040-0204	BEZEL:COUNTER	
11	08745-00047	FRONT PANEL	

Figure 5-2. Front Panel Assy

See introduction to this section for ordering information

Table 5-1. Reference Designation Index (Contd)

Reference Designation	Part No.	Description #	Note
			
Figure 5-3. Line Stretcher Assy Parts			
1	0370-0149	KNOB ASSEMBLY	
2	08740-2092	ADAPTER: SHAFT	
3	08741-2004	BEARING: PINION GEAR	
4	08742-2007	GEAR: PINION	
	3030-0060	SCREW: SET 2-56 X 1/8	
5	0510-0005	RING: RETAINING	
6	08741-2024	DRIVE SHAFT	
7	08741-6001	LEAD SCREW ASSEMBLY	
	3030-0022	SCREW: SET 6-32 X 1/8	
	08741-2022	LEAD SCREW HOUSING AND BUSHING	
	0520-0003	SCREW: RND HD 2-56 X 3/8	
	2190-0014	LOCKWASHER: 2-56	
	1410-0169	BEARING: BALL 0.250 ID X 0.625 OD	
8	2520-0001	SCREW: RND HD 8-32 X 1/4	
9	2360-0004	SCREW: RND HD 6-32 X 5/16	
	3050-0100	WASHER: 6-32 X 3/8	
	08740-0005	WASHER: SHIM CLUTCH	
10	1430-0356	GEAR: BEVEL	
11	5020-0392	WASHER: SPRING	
12	5020-0233	COLLAR: BRASS	
	3030-0001	SCREW: SET 8-32 X 3/16	
	624B-59C-5	BUSHING	
13	1460-0019	SPRING: COMPRESSION	
14	0510-0053	RING: GRIP	
15	1140-0008	END WHEEL	
16	1140-0007	NUMBER WHEEL	
17	1140-0009	UNIT WHEEL	
	1480-0072	PIN	
18	1430-0035	GEAR: PINION	
	08740-2014	SHAFT: IDLER	
19	08745-2025	THUMB WHEEL	
	3030-0033	SCREW: SET 6-32 X 3/16	
20	08742-2008	SHAFT: COUNTER	

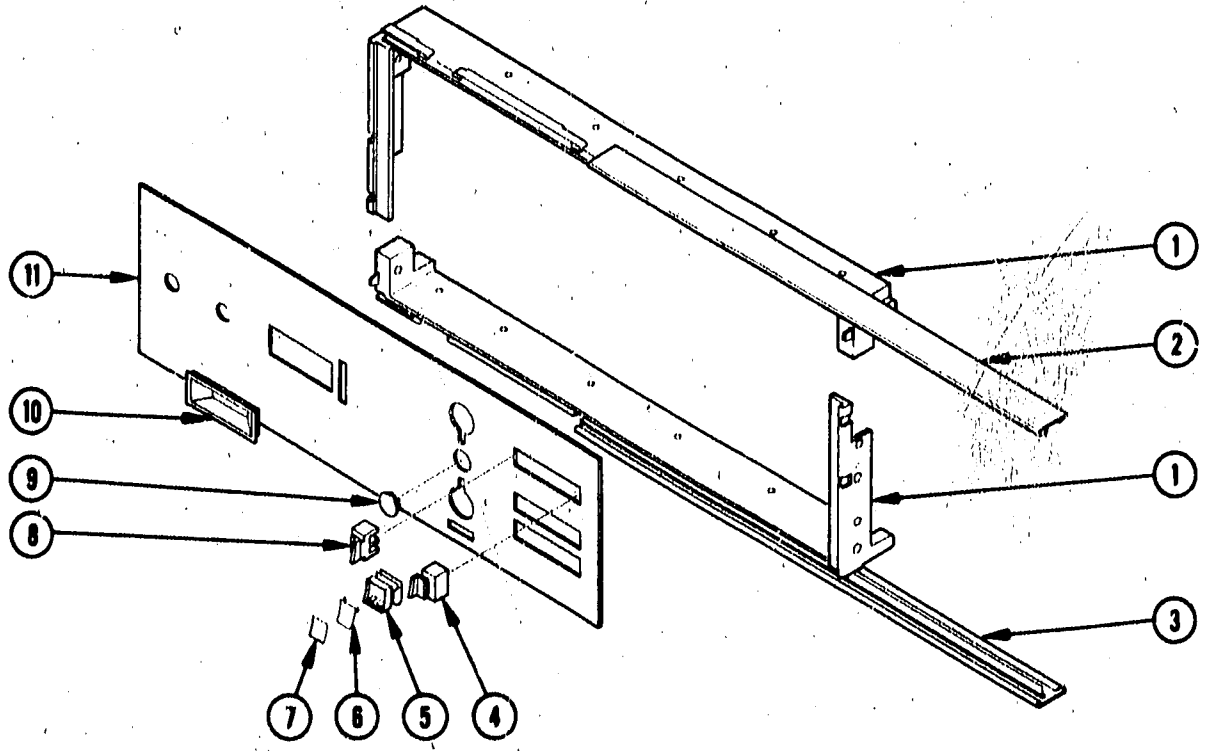
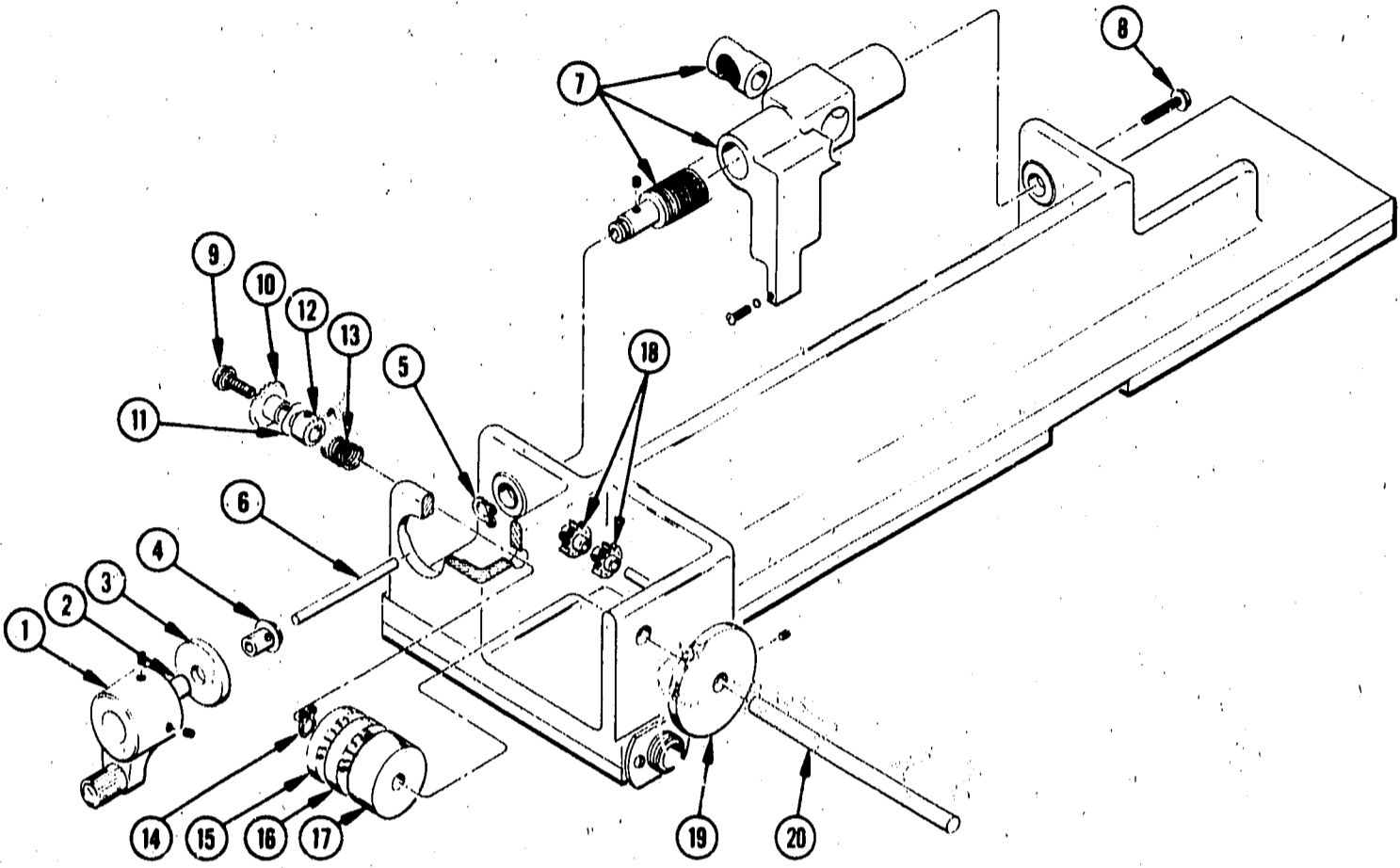
See introduction to this section for ordering information

Table 5-1. Reference Designation Index (Contd)

Reference Designation	Part No.	Description #	Note
			
1	0590-0035	NUT:CLAMP SST FOR 1/4" SHAFT	
2	08745-2021	CABLE:TERMINATOR	
3	2950-0079	NUT:HEX 5/8-24 THREAD	
4	2190-0493	WASHER:FLAT FOR 5/8" DIA SHAFT	
5	08741-2010	CENTER CONDUCTOR:TERMINATOR	
6	5040-0306	BEAD	
7	1250-0816	CONTACT:HOLDER	
8	08745-2047	CONNECTOR BODY:SST	

Figure 5-4. REFERENCE and TEST Channel Output and Coaxial Link Connector Parts

See introduction to this section for ordering information

Table 5-2. Replaceable Parts

Part No.	Description #	Mfr.	Mfr. Part No.	TQ
0150-0119	C:FXD CER 2 X 0.01 UF 20% 250WVAC	56289	36C219A	1
0150-0093	C:FXD CER 0.01 UF +80-20% 100VDCW	91418	TA	4
0180-0097	C:FXD ELECT 47 UF 10% 35VDCW	56289	150D476X9035S2	1
0180-0369	C:FXD ELECT 2800 UF +75-10% 60VDCW	56289	D39823	1
0180-2210	C:FXD ELECT 2 UF +50-10% 150VDCW	28480	0180-2210	4
0340-0092	INSULATOR:FEED-THRU	98291	FT-E-12	1
0370-0767	PUSHBUTTON:SWITCH,GRAY	28480	0370-0767	1
0370-0802	LENS:PUSHBUTTON	28480	0370-0802	1
0380-0719	STANDOFF:8-32 TAP	00000	OBD	1
0683-1055	R:FXD COMP 1 MEGOHM 5% 1/4W	01121	CB 1055	2
0683-3615	R:FXD COMP 360 OHM 5% 1/4W	01121	CB 3615	1
0683-4735	R:FXD COMP 47K OHM 5% 1/4W	01121	CB 4735	1
0698-0083	R:FXD MET FLM 1.96K OHM 1% 1/8W	28480	0698-0083	13
0698-3136	R:FXD MET FLM 17.8K OHM 1% 1/8W	28480	0698-3136	1
0698-3150	R:FXD MET FLM 2.37K OHM 1% 1/8W	28480	0698-3150	2
0698-3154	R:FXD MET FLM 4.22K OHM 1% 1/8W	28480	0698-3154	6
0698-3155	R:FXD MET FLM 4.64K OHM 1% 1/8W	28480	0698-3155	4
0698-3156	R:FXD MET FLM 14.7K OHM 1% 1/8W	28480	0698-3156	4
0698-3160	R:FXD MET FLM 31.6K OHM 1% 1/8W	28480	0698-3160	1
0698-3449	R:FXD MET FLM 28.7K OHM 1% 1/8W	28480	0698-3449	2
0757-0199	R:FXD MET FLM 21.5K OHM 1% 1/8W	28480	0757-0199	4
0757-0200	R:FXD MET FLM 5.62K OHM 1% 1/8W	28480	0757-0200	1
0757-0278	R:FXD MET FLM 1.78K OHM 1% 1/8W	28480	0757-0278	1
0757-0279	R:FXD MET FLM 3.16K OHM 1% 1/8W	28480	0757-0279	1
0757-0280	R:FXD MET FLM 1K OHM 1% 1/8W	28480	0757-0280	3
0757-0438	R:FXD MET FLM 5.11K OHM 1% 1/8W	28480	0757-0438	9
0757-0442	R:FXD MET FLM 10K OHM 1% 1/8W	28480	0757-0442	13
0757-0458	R:FXD MET FLM 51.1K OHM 1% 1/8W	28480	0757-0458	2
0757-0460	R:FXD MET FLM 61.9K OHM 1% 1/8W	28480	0757-0460	2
0757-0462	R:FXD MET FLM 75.0K OHM 1% 1/8W	28480	0757-0462	2
0757-0814	R:FXD MET FLM 511 OHM 1% 1/2W	28480	0757-0814	1
0757-1078	R:FXD MET FLM 1.47K OHM 1% 1/2W	28480	0757-1078	1
0758-0003	R:FXD MET OX 1000 OHM 5% 1/2W	28480	0758-0003	2
0758-0004	R:FXD MET OX 2700 OHM 5% 1/2W	28480	0758-0004	3
0758-0015	R:FXD MET OX 220 OHM 5% 1/2W	28480	0758-0015	6
0758-0034	R:FXD MET OX 2400 OHM 5% 1/2W	28480	0758-0034	2
0758-0043	R:FXD MET OX 1800 OHM 5% 1/2W	28480	0758-0043	2
0758-0063	R:FXD MET OX 1600 OHM 5% 1/2W	28480	0758-0063	1
0764-0016	R:FXD MET FLM 1000 OHM 5% 2W	28480	0764-0016	1
0811-1666	R:FXD WW 1.0 OHM 5% 2W	28480	0811-1666	1
1200-0092	BUSHING:TRANSISTOR	02735	495334 1	1
1251-0085	CONNECTOR:FEMALE 36-PIN MINIATURE	28480	1251-0085	1
1251-0148	CONNECTOR:AC 3-PRONG MALE	28480	1251-0148	1
1251-0213	CONNECTOR:PC 15 PIN	28480	1251-0213	1
1251-1886	CONNECTOR:PC 30 CONTACTS	28480	1251-1886	1
1251-2261	CONNECTOR:PC 15 PIN	76530	250-15-30-210	1
1400-0084	FUSEHOLDER:EXTRACTOR POST TYPE	79515	342014	1
1853-0020	TRANSISTOR:SILICON PNP	28480	1853-0020	5
1853-0027	TRANSISTOR:SILICON PNP	28480	1853-0027	4
1854-0039	TRANSISTOR:SILICON 2N3053	02735	2N3053	3
1854-0071	TRANSISTOR:SILICON NPN	28480	1854-0071	18
1854-0072	TRANSISTOR:SILICON NPN 2N3054	02735	2N3054	1
1901-0044	DIODE:SILICON 20MA/1V	28480	1901-0044	45
1901-0049	DIODE:SILICON 50PIV	28480	1901-0049	8
1902-0041	DIODE BREAKDOWN:5.11V 5% 400MW	28480	1902-0041	2
1902-0679	DIODE BREAKDOWN:17.4V 5%	28480	1902-0679	4
1902-3193	DIODE BREAKDOWN:13.3V 5%	28480	1902-3193	1

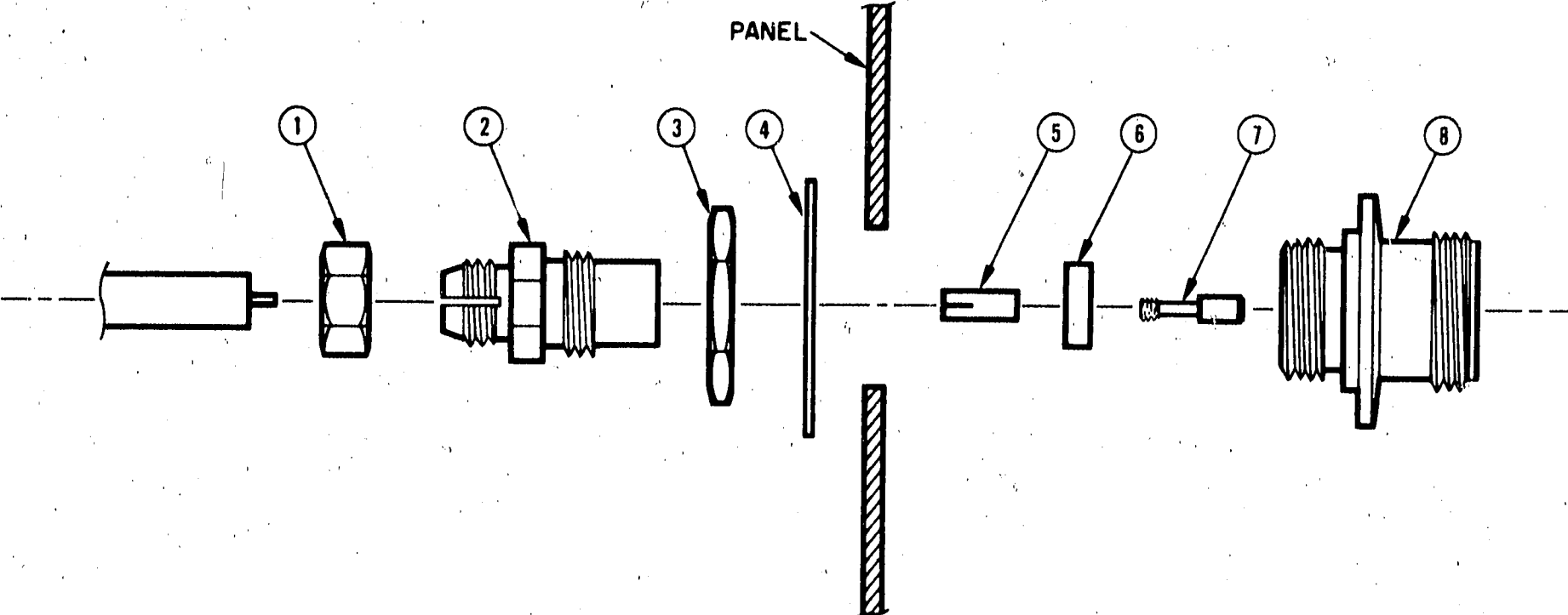
See introduction to this section for ordering information

Table 5-2. Replaceable Parts (Contd)

Part No.	Description #	Mfr.	Mfr. Part No.	TQ
1902-3290	DIODE BREAKDOWN: SILICON 31.6V 5%	28480	1902-3290	2
2110-0336	FUSE: CARTRIDGE 0.8 AMP 250V SLOW-BLOW	71400	MDL 8/10	1
2110-0340	FUSE: CARTRIDGE 0.4 AMP SLOW BLOW	71400	MPL 4/10	1
2140-0052	LAMP: GLOW	82047	A1H	1
2140-0300	LAMP: INCANDESCENT 18V 0.04A	24455	7370	6
3101-1234	SWITCH: SLIDE DPDT	82389	11A-1242	1
3101-1248	SWITCH: PUSHBUTTON SPDT	87034	53-55480-121/A1H	1
3106-0005	SWITCH: COAXIAL SPDT 24V	28480	3106-0005	2
5000-6400	LABEL: PUSHBUTTON (S11)	28480	5000-6400	1
5000-6401	LABEL: PUSHBUTTON (S12)	28480	5000-6401	1
5000-6402	LABEL: PUSHBUTTON (S21)	28480	5000-6402	1
5000-6403	LABEL: PUSHBUTTON (S22)	28480	5000-6403	1
5000-6452	LABEL: PUSHBUTTON (A)	28480	5000-6452	1
5000-6453	LABEL: PUSHBUTTON (B)	28480	5000-6453	1
5040-0273	INSULATOR: RF CONNECTOR	28480	5040-0273	2
6960-0002	PLUG: HOLE FOR 1/2" DIA	76530	SS-48152	1
6960-0010	PLUG: HOLE FOR 5/8" DIA	76530	SS-48172	1
8120-1348	CABLE ASSY: POWER CORD	28480	8120-1348	1
9100-2728	TRANSFORMER: 24.4V	28480	9100-2728	1
08742-2022	PIN: FEMALE	28480	08742-2022	2
08745-0019	BRACKET: SUPPORT	28480	08745-0019	1
08745-0037	BRACKET: SUPPORT	28480	08745-0037	1
08745-0039	BRACKET SUPPORT	28480	08745-0039	1
08745-0040	SUPPORT BRACKET: REAR	28480	08745-0040	1
08745-0041	BAR: CLAMPING	28480	08745-0041	1
08745-0042	BAR: CLAMPING	28480	08745-0042	1
08745-0043	BRACKET: HEAT SINK (BLACK)	28480	08745-0043	1
08745-0044	BAR: CLAMPING	28480	08745-0044	1
08745-2033	CABLE ASSY: A10 TO A11	28480	08745-2033	1
08745-2034	CABLE ASSY: A9 TO A11	28480	08745-2034	1
08745-2035	CABLE ASSY	28480	08745-2035	2
08745-2036	CABLE ASSY: A8 TO DC2	28480	08745-2036	1
08745-2047	TERMINATOR: HYBRID	28480	08745-2047	2
08745-2054	CLAMP EQUALIZER: REAR	28480	08745-2054	1
08745-2055	GUIDE: FRONT	28480	08745-2055	1
08745-6001	ASSY: LINE STRETCHER	28480	08745-6001	1
08745-6003	JUMPER WIRE: VIOLET	28480	08745-6003	1
08745-6009	DIRECTIONAL COUPLER (PAIR)	28480	08745-6009	1
08745-6024	ASSY: BIAS FILTER	28480	08745-6024	1
08745-6053	ASSY: RELAY DRIVE	28480	08745-6053	1
08745-6056	ASSY: POWER SUPPLY	28480	08745-6056	1
08745-6057	ASSY: INTERCONNECT	28480	08745-6057	1
08745-6058	ASSY: S-PARAMETER SWITCH	28480	08745-6058	1
08745-6102	ASSY: RF SOURCE RELAY	28480	08745-6102	1
08745-6103	INPUT RF SOURCE RELAY	28480	08745-6103	1
08745-20060	CABLE ASSY: A8 TO REAR PANEL	28480	08745-20060	1
08745-20062	CABLE ASSY: TEST OUT TO A7	28480	08745-20062	1
08745-20063	CABLE ASSY: REAR PANEL TO A6	28480	08745-20063	1
08745-20064	CABLE ASSY: REAR PANEL COAXIAL LINK	28480	08745-20064	1

See introduction to this section for ordering information.

TABLE 5-3.
CODE LIST OF MANUFACTURERS

The following code numbers are from the Federal Supply Code for Manufacturers Cataloging Handbooks H4-1 (Name to Code) and H4-2 (Code to Name) and their latest supplements. The date of revision and the date of the supplements used appear at the bottom of each page. Alphabetical codes have been arbitrarily assigned to suppliers not appearing in the H4 Handbooks.

Code No.	Manufacturer	Address	Code No.	Manufacturer	Address	Code No.	Manufacturer	Address
00000	U. S. A. Common	Any supplier of U. S.	05245	Components Corp.	Chicago, Ill.	09145	Tech. Ind. Inc. Atohm Elect.	Burbank, Calif.
00136	McCoy Electronics	Mount Holly Springs, Pa.	05277	Westinghouse Electric Corp.		09250	Electro Assemblies, Inc.	Chicago, Ill.
00213	Sage Electronics Corp.	Rochester, N. Y.		Semi-Conductor Dept.	Youngwood, Pa.	09353	C & K Components Inc.	Newton, Mass.
00287	Cemcc Inc.	Danielson, Conn.	05347	Ultronix, Inc.	San Mateo, Calif.	09569	Mallory Battery Co. of	
00334	Humidial	Colton, Calif.	05397	Union Carbide Corp., Elect. Div.			Canada, Ltd.	Toronto, Ontario, Canada
00348	Microtron Co., Inc.	Valley Stream, N. Y.			New York, N. Y.	03922	Burdny Corp.	Norwalk, Conn.
00373	Garlock Inc.	Cherry Hill, N. J.	05574	Viking Ind. Inc.	Canoga Park, Calif.	10214	General Transistor Western Corp.	
00656	Aerovox Corp.	New Bedford, Mass.	05593	Core Electro-Plastics Inc.	Sunnyvale, Calif.			Los Angeles, Calif.
00779	Amp. Inc.	Harrisburg, Pa.	05616	Cosmo Plastic		10411	Ti-Tal, Inc.	Berkeley, Calif.
00781	Aircraft Radio Corp.	Boonton, N. J.		(c/o Electrical Spec. Co.)	Cleveland, Ohio	10646	Carborundum Co.	Niagara Falls, N. Y.
00809	Crown Ltd.	Whitby, Ontario Canada	05624	Barber Colman Co.	Rockford, Ill.	11236	CTS of Berne, Inc.	Berne, Ind.
00815	Northern Engineering Laboratories, Inc.	Burlington, Wis.	05728	Tiffen Optical Co.		11237	Chicago Telephone of California, Inc.	
					Roslyn Heights, Long Island, N. Y.			So. Pasadena, Calif.
00853	Sangamo Electric Co., Pickens Div.	Pickens, S. C.	05729	Metro-Tel Corp.	Westbury, N. Y.	11242	Bay State Electronics Corp.	Waltham, Mass.
00866	Goe Engineering Co.	City of Industry, Cal.	05783	Stewart Engineering Co.	Santa Cruz, Calif.	11312	Teledyne Inc., Microwave Div.	Palo Alto, Calif.
00891	Carl E. Holmes Corp.	Los Angeles, Calif.	05820	Wakefield Engineering Inc.	Wakefield, Mass.	11314	National Seal	Downey, Calif.
00929	Microlab Inc.	Livingston, N. J.	06004	Bassick Co., Div. of Stewart Warner Corp.		11453	Precision Connector Corp.	Jamaica, N. Y.
01002	General Electric Co., Capacitor Dept.	Hudson Falls, N. Y.			Bridgeport, Conn.	11534	Duncan Electronics Inc.	Costa Mesa, Calif.
01009	Alden Products Co.	Brockton, Mass.	06090	Raychem Corp.	Redwood City, Calif.	11711	General Instrument Corp., Semiconductor	
01121	Allen Bradley Co.	Milwaukee, Wis.	06175	Bausch and Lomb Optical Co.	Rochester, N. Y.		Div., Products Group	Newark, N. J.
01255	Litton Industries, Inc.	Beverly Hills, Calif.	06402	E. T. A. Products Co. of America	Chicago, Ill.	11717	Imperial Electronic, Inc.	Buena Park, Calif.
01281	TRW Semiconductors, Inc.	Lawndale, Calif.	06540	Amatom Electronic Hardware Co., Inc.	New Rochelle, N. Y.	11870	Melabs, Inc.	Palo Alto, Calif.
01295	Texas Instruments, Inc., Transistor Products Div.	Dallas, Texas	06555	Beebe Electrical Instrument Co., Inc.	Penacook, N. H.	12040	National Semiconductor	Danbury, Conn.
01349	The Alliance Mfg. Co.	Alliance, Ohio	06666	General Devices Co., Inc.	Indianapolis, Ind.	12136	Philadelphia Handle Co.	Camden, N. J.
01538	Small Parts Inc.	Los Angeles, Calif.	06751	Components Inc., Ariz. Div.	Phoenix, Ariz.	12361	Grove Mfg. Co., Inc.	Shady Grove, Pa.
01589	Pacific Relays, Inc.	Van Nuys, Calif.	06812	Torrington Mfg. Co., West Div.		12574	Gulton Ind. Inc. Data System Div.	Albuquerque, N. M.
01670	Gudebrod Bros. Silk Co.	New York, N. Y.			Van Nuys, Calif.	12697	Clarostat Mfg. Co.	Dover, N. H.
01930	Amerock Corp.	Rockford, Ill.	06980	Varian Assoc. Eimac Div.	San Carlos, Calif.	12728	Elmar Filter Corp.	W. Haven, Conn.
01961	Pulse Engineering Co.	Santa Clara, Calif.	07088	Kelvin Electric Co.	Van Nuys, Calif.	12859	Nippon Electric Co., Ltd.	Tokyo, Japan
02114	Ferroxcube Corp. of America	Saugerties, N. Y.	07126	Digitran Co.	Pasadena, Calif.	12881	Metrex Electronics Corp.	Clark, N. J.
02116	Wheelock Signals, Inc.	Long Branch, N. J.	07137	Transistor Electronics Corp.	Minneapolis, Minn.	12930	Delta Semiconductor Inc.	Newport Beach, Calif.
02286	Cole Rubber and Plastics Inc.	Sunnyvale, Calif.	07138	Westinghouse Electric Corp.		12954	Dickson Electronics Corp.	Scottsdale, Arizona
02660	Amphenol-Borg Electronics Corp.	Broadview, Ill.		Electronic Tube Div.	Elmira, N. Y.	13019	Arco Supply Co., Inc.	Wichita, Kansas
02735	Radio Corp. of America, Semiconductor and Materials Div.	Somerville, N. J.	07149	Filmohm Corp.	New York, N. Y.	13103	Thermolloy	Dallas, Texas
02771	Vocaline Co. of America, Inc.	Old Saybrook, Conn.	07233	Cinch-Graphik Co.	City of Industry, Calif.	13396	Telefunken (GmbH)	Hanover, Germany
			07256	Silicon Transistor Co.	Carle Place, N. Y.	13835	Midland-Wright Div. of Pacific Industries, Inc.	
02777	Hopkins Engineering Co.	San Fernando, Calif.	07261	Avnet Corp.	Culver City, Calif.			Kansas City, Kansas
02875	Hudson Tool & Die Co.	Newark, N. J.	07263	Fairchild Camera & Inst. Corp.		14099	Sem-tech	Newbury Park, Calif.
03508	G. E. Semiconductor Prod. Dept.	Syracuse, N. Y.		Semiconductor Div.	Mountain View, Calif.	14193	Calif. Resistor Corp.	Santa Monica, Calif.
03705	Apex Machine & Tool Co.	Dayton, Ohio	07322	Minnesota Rubber Co.	Minneapolis, Minn.	14298	American Components, Inc.	Conshohocken, Pa.
03797	Eldema Corp.	Compton, Calif.	07387	Butcher Corp., The	Monterey Park, Calif.	14433	ITT Semiconductor, A Div. of Int. Telephone & Telegraph Corp.	West Palm Beach, Fla.
03818	Parker Seal Co.	Los Angeles, Calif.	07397	Sylvania Elect. Prod. Inc., Mt. View Operations	Mountain View, Calif.	14493	Hewlett-Packard Company	Coveland, Colo.
03877	Transitron Electric Corp.	Wakefield, Mass.	07700	Technical Wire Products Inc.	Cranford, N. J.	14655	Cornell Dublier Electric Corp.	Newark, N. J.
03888	Pyrofilm Resistor Co., Inc.	Cedar Knolls, N. J.	07829	Bodine Elect. Co.	Chicago, Ill.	14674	Corning Glass Works	Corning, N. Y.
03954	Singer Co., Diehl Div.	Sumerville, N. J.	07910	Continental Device Corp.	Hawthorne, Calif.	14752	Electro Cube Inc.	San Gabriel, Calif.
	Finderne Plant		07933	Raytheon Mfg. Co., Semiconductor Div.	Mountain View, Calif.	14960	Williams Mfg. Co.	San Jose, Calif.
04009	Arrow, Hart and Hegeman Elect. Co.	Hartford, Conn.	07980	Hewlett-Packard Co., Boonton Radio Div.	Boonton, N. J.	15106	The Spence Co., Inc.	Little Falls, N. J.
04013	Taurus Corp.	Lambertville, N. J.			Knockaway, N. J.	15203	Webster Electronics Co.	New York, N. Y.
04062	Arco Electronic Inc.	Great Neck, N. Y.	08145	U. S. Engineering Co.	Los Angeles, Calif.	15287	Scionics Corp.	Northridge, Calif.
04217	Essex Wire	Los Angeles, Calif.	08289	Blinn, Delbert Co.	Pomona, Calif.	15291	Adjustable Bushing Co.	N. Hollywood, Calif.
04222	Hi-Q Division of Aerovox	Myrtle Beach, S. C.	08358	Burgess Battery Co.		15558	Micron Electronics	Garden City, Long Island, N. Y.
04354	Precision Paper Tube Co.	Wooling, Ill.			Niagara Falls, Ontario, Canada	15566	Amprobe Inst. Corp.	Lynbrook, N. Y.
04404	Dymec Division of Hewlett-Packard Co.	Palo Alto, Calif.	08524	Deutsch Fastener Corp.	Los Angeles, Calif.	15631	Cabletronics	Costa Mesa, Calif.
04651	Sylvania Electric Products, Microwave Device Div.	Mountain View, Calif.	08664	Bristol Co., The	Waterbury, Conn.	15772	Twentieth Century Coil Spring Co.	
04673	Dakota Eng. Inc.	Culver City, Calif.	08717	Sloan Company	Sun Valley, Calif.			Santa Clara, Calif.
04713	Motorola, Inc., Semiconductor Prod. Div.	Phoenix, Arizona	08718	ITT Cannon Electric Inc., Phoenix Div.	Phoenix, Arizona	15801	Fenwal Elect. Inc.	Framingham, Mass.
04732	Filltron Co., Inc. Western Div.	Culver City, Calif.			Paramus, N. J.	15818	Amelco Inc.	Mt. View, Calif.
04773	Automatic Electric Co.	Northlake, Ill.	08727	National Radio Lab. Inc.		16037	Spruce Pine Mica Co.	Spruce Pine, N. C.
04796	Sequoia Wire Co.	Redwood City, Calif.	08792	CBS Electronics Semiconductor Operations, Div. of C. B. S. Inc.	Lowell, Mass.	16179	Omni-Spectra Inc.	Farmington, Mich.
04811	Precision Coil Spring Co.	El Monte, Calif.				16352	Computer Diode Corp.	Lodi, N. J.
04870	P. M. Motor Company	Westchester, Ill.	08806	General Electric Co. Miniat. Lamp Dept.	Cleveland, Ohio	16585	Boots Aircraft Nut Corp.	Pasadena, Calif.
04919	Component Mfg. Service Co.	W. Bridgewater, Mass.			Indianapolis, Ind.	16688	Ideal Prec. Meter Co., Inc.	
05006	Twentieth Century Plastics, Inc.	Los Angeles, Calif.	08984	Mel-Rain	Indianapolis, Ind.		De Jur Meter Div.	Brooklyn, N. Y.
			09026	Babcock Relays Div.	Costa Mesa, Calif.	16758	Delco Radio Div. of G. M. Corp.	Kokoma, Ind.
			09134	Texas Capacitor Co.	Houston, Texas	17109	Thermonetics Inc.	Canoga Park, Calif.
						17474	Tranex Company	Mountain View, Calif.
						17554	Components Inc.	Biddford, Me.
						17775	Hamlin Metal Products Corp.	Akron, Ohio
						17745	Angstrom Prec. Inc.	No. Hollywood, Calif.
						17856	Siliconix Inc.	Sunnyvale, Calif.

00015-48

Revised October, 1969

From: FSC Handbook Supplements

TABLE 5-3.
CODE LIST OF MANUFACTURERS (Continued)

Code No.	Manufacturer	Address	Code No.	Manufacturer	Address	Code No.	Manufacturer	Address
17870	McGraw-Edison Co.	Manchester, N. H.	62119	Universal Electric Co.	Owosso, Mich.	73899	JFD Electronics Corp.	Brooklyn, N. Y.
18042	Power Design Pacific Inc.	Palo Alto, Calif.	63743	Ward-Leonard Electric Co.	Mt. Vernon, N. Y.	73905	Jennings Radio Mfg. Corp.	San Jose, Calif.
18083	Clevite Corp., Semiconductor Div.	Palo Alto, Calif.	64959	Western Electric Co., Inc.	New York, N. Y.	73957	Groov-Pin Corp.	Ridgefield, N. J.
			65092	Weston Inst. Inc. Weston-Newark	Newark, N. J.	74276	Signalite Inc.	Neptune, N. J.
18324	Signetics Corp.	Sunnyvale, Calif.	66295	Wittek Mfg. Co.	Chicago, Ill.	74455	J. H. Winns, and Sons	Winchester, Mass.
18476	Ty-Car Mfg. Co., Inc.	Holliston, Mass.	66346	Minnesota Mining & Mfg. Co. Revere Mincom Div.	St. Paul, Minn.	74861	Industrial Condenser Corp.	Chicago, Ill.
18486	TRW Elect. Comp. Div.	Des Plaines, Ill.			Hartford, Conn.	74868	R. F. Products Division of Amphenol-Borg Electronics Corp.	Danbury, Conn.
18583	Curtis Instrument, Inc.	Mt. Kisco, N. Y.	70276	Allen Mfg. Co.	Hartford, Conn.	74970	E. F. Johnson Co.	Waseca, Minn.
18612	Vishay Instruments Inc.	Malvern, Pa.	70309	Allied Control	New York, N. Y.	75042	International Resistance Co.	Philadelphia, Pa.
18873	E. I. DuPont and Co., Inc.	Wilmington, Del.	70318	Allmetal Screw Product Co., Inc.	Garden City, N. Y.	75263	Keystone Carbon Co., Inc.	St. Marys, Pa.
18911	Durant Mfg. Co.	Milwaukee, Wis.				75378	CTS Knights Inc.	Sandwich, Ill.
19315	The Bendix Corp., Navigation & Control Div.	Teterboro, N. J.	70417	Amplex, Div. of Chrysler Corp.	Detroit, Mich.	75382	Kulka Electric Corporation	Mt. Vernon, N. Y.
			70485	Atlantic Indra Rubber Works, Inc.	Chicago, Ill.	75818	Lenz Electric Mfg. Co.	Chicago, Ill.
19500	Thomas A. Edison Industries, Div. of McGraw-Edison Co.	West Orange, N. J.	70563	Amperite Co., Inc.	Union City, N. J.	75915	Littlefuse, Inc.	Des Plaines, Ill.
19589	Concoa	Baldwin Park, Calif.	70674	ADC Products Inc.	Minneapolis, Minn.	76005	Lord Mfg. Co.	Erie, Pa.
19644	LRC Electronics	Horseheads, N. Y.	70903	Belden Mfg. Co.	Chicago, Ill.	76210	C. W. Marwedel	San Francisco, Calif.
19701	Electra Mfg. Co.	Independence, Kansas	70998	Bird Electronic Corp.	Cleveland, Ohio	76433	General Instrument Corp., Micamold Division	Newark, N. J.
20183	General Atomics Corp.	Philadelphia, Pa.	71002	Birnbach Radio Co.	New York, N. Y.			
21226	Executone, Inc.	Long Island City, N. Y.	71034	Bliley Electric Co., Inc.	Erie, Pa.	76487	James Millen Mfg. Co., Inc.	Malden, Mass.
21335	Falnir Bearing Co., The	New Britain, Conn.	71041	Boston Gear Works Div. of Murray Co. of Texas	Quincy, Mass.	76493	J. W. Miller Co.	Los Angeles, Calif.
21520	Fansteel Metallurgical Corp.	N. Chicago, Ill.	71218	Bud Radio, Inc.	Willoughby, Ohio	76530	Cinch-Monadnock, Div. of United Carr Fastener Corp.	San Leandro, Calif.
23042	Texscan Corp.	Indianapolis, Ind.	71279	Cambridge Thermionics Corp.	Cambridge, Mass.	76545	Mueller Electric Co.	Cleveland, Ohio
23783	British Radio Electronics Ltd.	Washington, D. C.	71286	Camloc Fastener Corp.	Paramus, N. J.	76703	National Union	Newark, N. J.
24455	G. E. Lamp Division	Nela Park, Cleveland, Ohio	71313	Cardwell Condenser Corp.	Lindenhurst L. I., N. Y.	76854	Oak Manufacturing Co.	Crystal Lake, Ill.
			71400	Bussmann Mfg. Div. of McGraw-Edison Co.	St. Louis, Mo.	77068	The Bendix Corp., Electrodynamics Div.	N. Hollywood, Calif.
24655	General Radio Co.	West Concord, Mass.	71436	Chicago Condenser Corp.	Chicago, Ill.	77075	Pacific Metals Co.	San Francisco, Calif.
24681	Memcor Inc., Comp. Div.	Huntington, Ind.	71447	Calif. Spring Co., Inc.	Pico-Rivera, Calif.	77221	Phanotron Instrument and Electronic Co.	South Pasadena, Calif.
24796	Parelco Inc.	San Juan Capistrano, Calif.	71450	GTS Corp.	Elkhart, Ind.	77252	Philadelphia Steel and Wire Corp.	Philadelphia, Pa.
26365	Gries Reproducer Corp.	New Rochelle, N. Y.	71468	ITT Cannon Electric Inc.	Los Angeles, Calif.	77342	American Machine & Foundry Co. Potter & Brumfield Div.	Princeton, Ind.
26462	Grobet File Co. of America, Inc.	Carlstadt, N. J.	71471	Cinema, Div. Aerovox Corp.	Burbank, Calif.	77630	TRW Electronic Components Div.	Camden, N. J.
			71482	C. P. Clare & Co.	Chicago, Ill.	77638	General Instrument Corp., Rectifier Div.	Brooklyn, N. Y.
26851	Compac/Hollister Co.	Hollister, Calif.	71590	Centrab Div. of Globe Union Inc.	Milwaukee, Wis.	77764	Resistance Products Co.	Harrisburg, Pa.
26992	Hamilton Watch Co.	Lancaster, Pa.	71616	Commercial Plastics Co.	Chicago, Ill.	77969	Rubbercraft Corp. of Calif.	Torrance, Calif.
27251	Specialities Mfg. Co., Inc.	Stratford, Conn.	71700	Cornish Wire Co., The	New York, N. Y.	78189	Shakeproof Division of Illinois Tool Works	Elgin, Ill.
28480	Hewlett-Packard Co.	Palo Alto, Calif.	71707	Coto Coil Co., Inc.	Providence, R. I.	78277	Sigma	So. Braintree, Mass.
28520	Heyman Mfg. Co.	Kenilworth, N. J.	71744	Chicago Miniature Lamp Works	Chicago, Ill.	78283	Signal Indicator Corp.	New York, N. Y.
30817	Instrument Specialties Co., Inc.	Little Falls, N. J.	71785	Cinch Mfg. Co., Howard B. Jones Div.	Chicago, Ill.	78290	Struthers-Dunn Inc.	Pitman, N. J.
						78424	Speciality Leather Prod. Co.	Newark, N. J.
33173	G. E. Receiving Tube Dept.	Owensboro, Ky.	71984	Dow Corning Corp.	Midland, Mich.	78452	Thompson-Bremer & Co.	Chicago, Ill.
35434	Lectrohm Inc.	Chicago, Ill.	72136	Electro Motive Mfg. Co., Inc.	Willimantic, Conn.	78471	Tilley Mfg. Co.	San Francisco, Calif.
36196	Stanwyck Coil Products Ltd.	Hawkesbury, Ontario, Canada	72619	Dialight Corp.	Brooklyn, N. Y.	78488	Stackpole Carbon Co.	St. Marys, Pa.
			72656	Indiana General Corp., Electronics Div.	Keasby, N. J.	78493	Standard Thomson Corp.	Waltham, Mass.
36287	Cunningham, W. H. & Hill, Ltd.	Toronto Ontario, Canada	72699	General Instrument Corp., Cap. Div.	Newark, N. J.	78553	Trimmerman Products, Inc.	Cleveland, Ohio
			72765	Drake Mfg. Co.	Harwood Heights, Ill.	78790	Transformer Engineers	San Gabriel, Calif.
37942	P. R. Mallory & Co. Inc.	Indianapolis, Ind.	72825	Hugh H. Eby Inc.	Philadelphia, Pa.	78947	Ucinite Co.	Newtonville, Mass.
39543	Mechanical Industries Prod. Co.	Akron, Ohio	72928	Gudeman Co.	Chicago, Ill.	79136	Waldes Kohinor Inc.	Long Island City, N. Y.
40920	Miniature Precision Bearings, Inc.	Keene, N. H.	72962	Elastic Stop Nut Corp.	Union, N. J.	79142	Veeder Root, Inc.	Hartford, Conn.
42190	Muter Co.	Chicago, Ill.	72964	Robert M. Hadley Co.	Los Angeles, Calif.	79251	Wenco Mfg. Co.	Chicago, Ill.
43990	C. A. Norgren Co.	Englewood, Colo.	72982	Erro Technological Products, Inc.	Erie, Pa.	79727	Continental-Wirt Electronics Corp.	Philadelphia, Pa.
44655	Ohmite Mfg. Co.	Skokie, Ill.	73061	Hansen Mfg. Co., Inc.	Princeton, Ind.			
46384	Penn Eng. & Mfg. Corp.	Doylestown, Pa.	73076	H. M. Harper Co.	Chicago, Ill.	79963	Ziorick Mfg. Corp.	New Rochelle, N. Y.
47904	Polaroid Corp.	Cambridge, Mass.	73138	Helipot Div. Beckman Inst., Inc.	Fullerton, Calif.	80031	Mepco Division of Sessions Clock Co.	Morristown, N. J.
48620	Precision Thermometer & Inst. Co.	Southampton, Pa.						
			73293	Hughes Products Division of Hughes Aircraft Co.	Newport Beach, Calif.	80033	Prestole Corp.	Toledo, Ohio
49956	Microwave & Power Tube Div.	Waltham, Mass.	73445	Amperex Elect. Co.	Hicksville, L. I., N. Y.	80120	Schnitzer Alloy Products Co.	Elizabeth, N. J.
52090	Rowan Controller Co.	Westminster, Md.	73506	Bradley Semiconductor Corp.	New Haven, Conn.	80131	Electronic Industries Association. Any brand Tube meeting EIA Standards-Washington, DC.	
52983	Sanborn Company	Waltham, Mass.	73559	Carling Electric, Inc.	Hartford, Conn.	80207	Unimax Switch, Div. Maxon Electronics Corp.	Wallingford, Conn.
54294	Shallcross Mfg. Co.	Selma, N. C.	73586	Circle F Mfg. Co.	Trenton, N. J.			
55026	Simpson Electric Co.	Chicago, Ill.	73682	George K. Garrett Co., Div. MSL Industries Inc.	Philadelphia, Pa.	80223	United Transformer Corp.	New York, N. Y.
55933	Sonotone Corp.	Elmsford, N. Y.				80248	Oxford Electric Corp.	Chicago, Ill.
55938	Raytheon Co. Commercial Apparatus & Systems Div.	So. Norwalk, Conn.	73734	Federal Screw Products Inc.	Chicago, Ill.	80294	Bourns Inc.	Riverside, Calif.
56137	Spaulding Fibre Co., Inc.	Tonawanda, N. Y.	73743	Fischer Special Mfg. Co.	Cincinnati, Ohio	80411	Acro Div. of Robertshaw Controls Co.	Columbus, Ohio
56289	Sprague Electric Co.	North Adams, Mass.	73793	General Industries Co., The	Elyria, Ohio			
59446	Telex Corp.	Tulsa, Okla.	73846	Goshen Stamping & Tool Co.	Goshen, Ind.			
59730	Thomas & Betts Co.	Elizabeth, N. J.						
60741	Triplett Electrical Inst. Co.	Bluffton, Ohio						
61775	Union Switch and Signal, Div. of Westinghouse Air Brake Co.	Pittsburgh, Pa.						

TABLE 5-3.
CODE LIST OF MANUFACTURERS (Continued)

Code No.	Manufacturer	Address	Code No.	Manufacturer	Address	Code No.	Manufacturer	Address
80486	All Star Products Inc.	Defiance, Ohio	86684	Radio Corp. of America, Electronic Comp. & Devices Div.	Harrison, N. J.	95566	Arnold Engineering Co.	Marengo, Ill.
80509	Avery Label Co.	Monrovia, Calif.	86928	Seastrom Mfg. Co.	Glendale, Calif.	95712	Dage Electric Co., Inc.	Franklin, Ind.
80583	Hammarlund Co., Inc.	Mars Hill, N. C.	87034	Marco Industries	Anahaim, Calif.	95984	Sieron Mfg. Co.	Wayne, Ill.
80640	Stevens, Arnold, Co., Inc.	Boston, Mass.	87216	Phitco Corporation (Lansdale Division)	Lansdale, Pa.	95987	Weckesser Co.	Chicago, Ill.
80813	Dimco Gray Co.	Dayton, Ohio	87473	Western Fibrous Glass Products Co.	San Francisco, Calif.	96067	Microwave Assoc., West Inc.	Sunnyvale, Calif.
81030	International Instruments Inc.	Orange, Conn.	87564	Van Waters & Rogers Inc.	San Francisco, Calif.	96095	Hi-Q Div. of Aerovox Corp.	Olean, N. Y.
81073	Grayhill Co.	LaGrange, Ill.	87930	Tower Mfg. Corp.	Providence, R. I.	96256	Thordarson-Meissner Inc.	Mt. Carmel, Ill.
81095	Triad Transformer Corp.	Venice, Calif.	88140	Cutler-Hammer, Inc.	Lincoln, Ill.	96296	Solar Manufacturing Co.	Los Angeles, Calif.
81312	Winchester Elec. Div. Litton Ind., Inc.	Oakville, Conn.	88220	Gould-National Batteries, Inc.	St. Paul, Minn.	96306	Microswitch, Div. of Minn.-Honeywell	Freeport, Ill.
81349	Military Specification		88698	General Mills, Inc.	Buffalo, N. Y.	96330	Carlton Screw Co.	Chicago, Ill.
81483	International Rectifier Corp.	El Segundo, Calif.	89231	Graybar Electric Co.	Oakland, Calif.	96341	Microwave Associates, Inc.	Burlington, Mass.
81541	Airpax Electronics, Inc.	Cambridge, Maryland	89473	G. E. Distributing Corp.	Schenectady, N. Y.	96501	Excel Transformer Co.	Oakland, Calif.
81860	Barry Controls, Div. Barry Wright Corp.	Watertown, Mass.	89665	United Transformer Co.	Chicago, Ill.	96508	Xcelite Inc.	Orchard Park, N. Y.
82042	Carter Precision Electric Co.	Skokie, Ill.	90030	United Shoe Machinery Corp.	Beverly, Mass.	96733	San Fernando Elect. Mfg. Co.	San Fernando, Calif.
82047	Sperli Faraday Inc., Copper Hewitt Electric Div.	Hoboken, N. J.	90179	US Rubber Co., Consumer Ind. & Plastics Prod. Div.	Passaic, N. J.	96881	Thomson Ind. Inc.	Long Is., N. Y.
82116	Electric Regulator Corp.	Norwalk, Conn.	90763	United Carr Fastener Corp.	Chicago, Ill.	97464	Industrial Retaining Ring Co.	Irvington, N. J.
82142	Jeffers Electronics Division of Speer Carbon Co.	Du Bois, Pa.	90970	Bearing Engineering Co.	San Francisco, Calif.	97539	Automatic & Precision Mfg.	Englewood, N. J.
82170	Fairchild Camera & Inst. Corp. Space & Defense System Div.	Paramus, N. J.	91146	ITT Cannon Elect. Inc., Salem Div.	Salem, Mass.	97979	Reon Resistor Corp.	Yonkers, N. Y.
82209	Maguire Industries, Inc.	Greenwich, Conn.	91260	Connor Spring Mfg. Co.	San Francisco, Calif.	97983	Litton System Inc., Adler-Westrex Commun. Div.	New Rochelle, N. Y.
82219	Sylvania Electric Prod. Inc. Electronic Tube Division	Emporium, Pa.	91345	Miller Dial & Nameplate Co.	El Monte, Calif.	98141	R-Tronics, Inc.	Jamaica, N. Y.
82376	Astron Corp.	East Newark, N. J.	91418	Radio Materials Co.	Chicago, Ill.	98159	Rubber Teck, Inc.	Gardena, Calif.
82389	Switchcraft, Inc.	Chicago, Ill.	91506	Augat Inc.	Attleboro, Mass.	98220	Hewlett-Packard Co., Moseley Div.	Pasadena, Calif.
82647	Metals & Controls Inc. Spencer Products	Attleboro, Mass.	91637	Dale Electronics, Inc.	Columbus, Nebr.	98278	Microdot, Inc.	So. Pasadena, Calif.
82768	Phillips-Advance Control Co.	Joliet, Ill.	91662	Elco Corp.	Willow Grove, Pa.	98291	Sealectro Corp.	Mamaroneck, N. Y.
82866	Research Products Corp.	Madison, Wis.	91737	Gremar Mfg. Co., Inc.	Waketfield, Mass.	98376	Zero Mfg. Co.	Burbank, Calif.
82877	Rotron Mfg. Co., Inc.	Woodstock, N. Y.	91827	K F Development Co.	Redwood City, Calif.	98410	Etc Inc.	Cleveland, Ohio
82893	Vector Electronic Co.	Glendale, Calif.	91886	Malco Mfg. Co., Inc.	Chicago, Ill.	98731	General Mills Inc., Electronics Div.	Minneapolis, Minn.
83014	Hartwell Corp.	Los Angeles, Calif.	91929	Honeywell Inc., Micro Switch Div.	Freeport, Ill.	98734	Paeco Div. of Hewlett-Packard Co.	Palo Alto, Calif.
83058	Carr Fastener Co.	Cambridge, Mass.	91961	Nahm-Bros. Spring Co.	Oakland, Calif.	98821	North Hills Electronics, Inc.	Glen Cove, N. Y.
83086	New Hampshire Ball Bearing, Inc.	Peterborough, N. H.	92180	Tru-Connector Corp.	Peabody, Mass.	98978	International Electronic Research Corp.	Burbank, Calif.
83125	General Instrument Corp., Capacitor Div.	Darlington, S. C.	92367	Elgeet Optical Co. Inc.	Rochester, N. Y.	99109	Columbia Technical Corp.	New York, N. Y.
83148	ITT Wire and Cable Div.	Los Angeles, Calif.	92607	Tensolite Insulated Wire Co., Inc.	Tarrytown, N. Y.	99313	Varian Associates	Palo Alto, Calif.
83186	Victory Eng. Corp.	Springfield, N. J.	92702	IMC Magnetics Corp.	Wesbury Long Island, N. Y.	99378	Ailee Corp.	Winchester, Mass.
83298	Bendix Corp., Red Bank Div.	Red Bank, N. J.	92966	Hudson Lamp Co.	Kearney, N. J.	99515	Marshall Ind., Capacitor Div.	Monrovia, Calif.
83315	Hubbell Corp.	Mundelein, Ill.	93332	Sylvania Electric Prod. Inc. Semiconductor Div.	Woburn, Mass.	99707	Control Switch Division, Controls Co. of America	El Segundo, Calif.
83324	Rosan Inc.	Newport Beach, Calif.	93360	Robbins & Myers Inc.	Palisades Park, N. J.	99800	Delevan Electronics Corp.	East Aurora, N. Y.
83330	Smith, Herman H., Inc.	Brooklyn, N. Y.	93410	Stemco Controls, Div. of Essex Wire Corp.	Mansfield, Ohio	99848	Wilco Corporation	Indianapolis, Ind.
83332	Tech Labs	Pallsade's Park, N. J.	93632	Waters Mfg. Co.	Culver City, Calif.	99928	Branson Corp.	Whippany, N. J.
83385	Central Screw Co.	Chicago, Ill.	93929	G. V. Controls	Livingston, N. J.	99934	Renbrandt, Inc.	Boston, Mass.
83501	Gavitt Wire and Cable Co. Div. of Amerace Corp.	Brookfield, Mass.	94137	General Cable Corp.	Bayonne, N. J.	99942	Hoffman Electronics Corp. Semiconductor Div.	El Monte, Calif.
83594	Burroughs Corp. Electronic Tube Div.	Plainfield, N. J.	94142	Phelps Dodge	Yonkers, N. Y.	99957	Technology Instrument Corp. of Calif.	Newbury Park, Calif.
83740	Union Carbide Corp. Consumer Prod. Div.	New York, N. Y.	94144	Raytheon Co., Comp. Div., Ind. Comp. Operations	Quincy, Mass.			
83777	Model Eng. and Mfg., Inc.	Huntington, Ind.	94148	Scientific Electronics Products, Inc.	Loveland, Colo.			
83821	Loyd Scruggs Co.	Festus, Mo.	94154	Wagner Elect. Corp., Tung-Sol Div.	Newark, N. J.			
83942	Aeronautical Inst. & Radio Co.	Lodi, N. J.	94197	Curtiss-Wright Corp. Electronics Div.	East Paterson, N. J.			
84171	Arco Electronics Inc.	Great Neck, N. Y.	94222	South Chester Corp.	Chester, Pa.			
84396	A. J. Giesener Co., Inc.	San Francisco, Calif.	94330	Wire Cloth Products, Inc.	Bellwood, Ill.			
84411	TRW Capacitor Div.	Ogallala, Neb.	94375	Automatic Metal Products Co.	Brooklyn, N. Y.			
84970	Sarkes Tarzian, Inc.	Bloomington, Ind.	94682	Worcester Pressed Aluminum Corp.	Worcester, Mass.			
85454	Boonton Molding Company	Boonton, N. J.	94696	Magnecraft Electric Co.	Chicago, Ill.	0000F	Malco Tool and Die	Los Angeles, Calif.
85471	A. B. Boyd Co.	San Francisco, Calif.	95023	George A. Philbrick Researchers, Inc.	Boston, Mass.	0000Z	Willow Leather Products Corp.	Newark, N. J.
85474	R. M. Bracamonte & Co.	San Francisco, Calif.	95236	Allies Products Corp.,	Dania, Fla.	000AB	ETA	England
85660	Kolled Kords, Inc.	Hamden, Conn.	95238	Continental Connector Corp.	Woodside, N. Y.	000BB	Precision Instrument Components Co.	Van Nuys, Calif.
85911	Seamless Rubber Co.	Chicago, Ill.	95263	Leecraft Mfg. Co., Inc.	Long Island, N. Y.	000CS	Hewlett-Packard Co.,	Colorado Springs
86174	Fafnir Bearing Co.	Los Angeles, Calif.	95265	National Coil Co.	Sheridan, Wyo.			
86197	Clifton Precision Products Co., Inc.	Clifton Heights, Pa.	95275	Vitramon, Inc.	Bridgeport, Conn.	000MW	Rubber Eng. & Development	Hayward, Calif.
86579	Precision Rubber Products Corp.	Dayton, Ohio	95348	Gordos Corp.	Bloomfield, N. J.	000NN	A "N" D Mfg. Co.	San Jose, Calif.
			95354	Methode Mfg. Co.	Rolling Meadows, Ill.	000QQ	Coultron	Oakland, Calif.
						000WW	California Eastern Lab.	Burlington, Calif.
						000YY	S. K. Smith Co.	Los Angeles, Calif.

THE FOLLOWING HP VENDORS HAVE NO NUMBER ASSIGNED IN THE LATEST SUPPLEMENT TO THE FEDERAL SUPPLY CODE FOR MANUFACTURERS HANDBOOK.

0000F	Malco Tool and Die	Los Angeles, Calif.
0000Z	Willow Leather Products Corp.	Newark, N. J.
000AB	ETA	England
000BB	Precision Instrument Components Co.	Van Nuys, Calif.
000CS	Hewlett-Packard Co.,	Colorado Springs
000MW	Rubber Eng. & Development	Hayward, Calif.
000NN	A "N" D Mfg. Co.	San Jose, Calif.
000QQ	Coultron	Oakland, Calif.
000WW	California Eastern Lab.	Burlington, Calif.
000YY	S. K. Smith Co.	Los Angeles, Calif.

SCHEMATIC DIAGRAMS

SECTION VI SCHEMATIC DIAGRAMS

6-1. INTRODUCTION.

6-2. The schematic diagrams in this section represent the circuits electrically. They are not wiring diagrams, though wire colors are given where practical.

6-3. The circuits are arranged according to signal flow; consequently, some switch and circuit assemblies may be shown in part on more than one diagram. If so, the reference designation is preceded by P/O, for "Part Of", and is followed by a notation of the

number of parts into which the assembly has been divided.

6-4. Some of the general information obtainable from the schematic diagrams is shown in Figure 6-1. Notes and explanations of symbols pertaining to all the diagrams are contained in Figure 6-2. Notes about specific components, circuits, or conditions are given on the diagram to which they apply.

6-5. As an aid to finding components and assemblies in the set of diagrams, each diagram has a box labelled Reference Designations that contains all the reference designations appearing on the diagram.

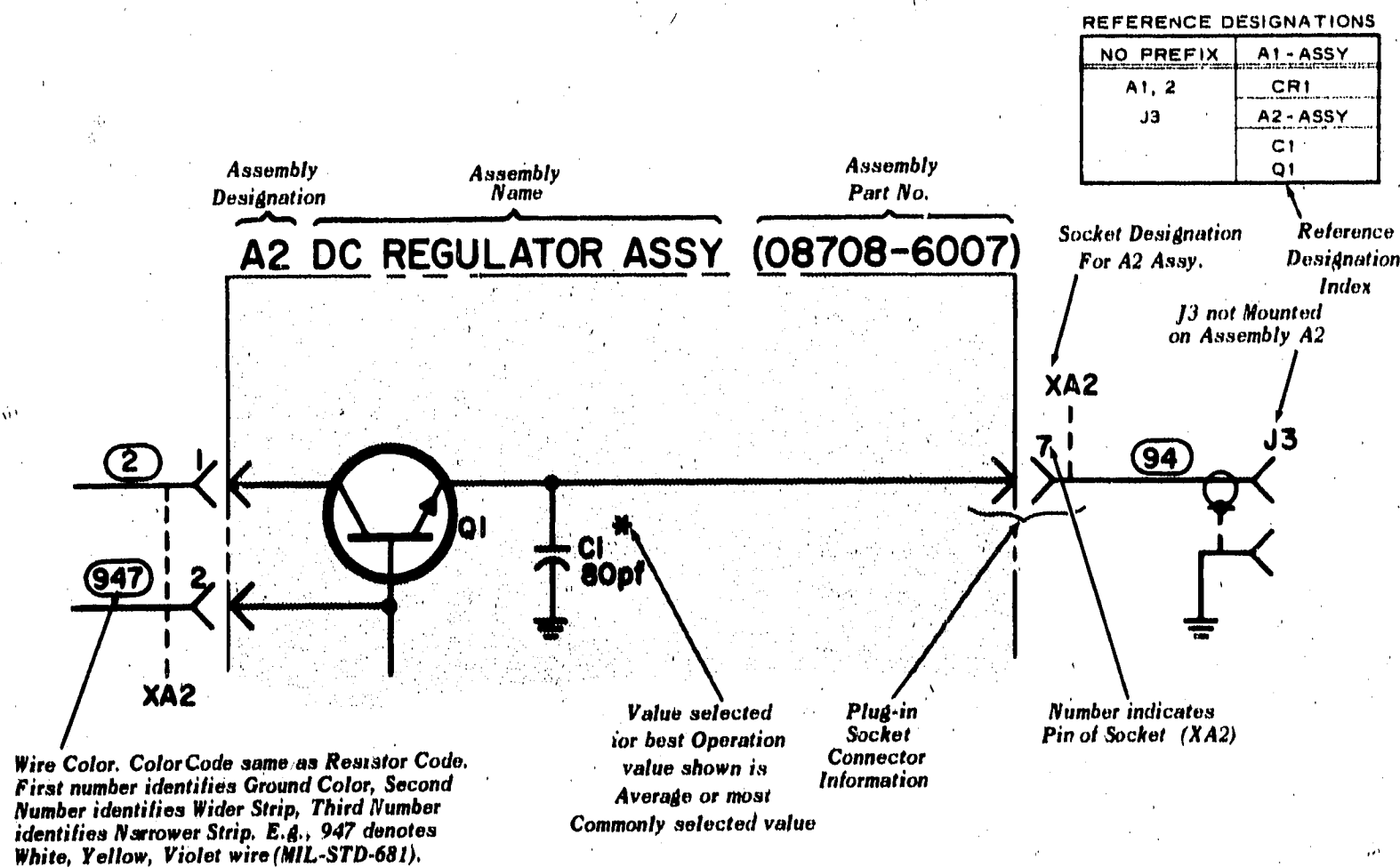

Figure 6-1. General Information on Schematic Diagrams

SCHEMATIC DIAGRAM NOTES









1. Resistance in ohms, capacitance in microfarads unless otherwise noted.
2. Voltages shown on schematic diagrams taken with HP 414A AUTOVOLTMETER: input resistance 100 M Ω , accuracy $\pm(1\%$ of reading $+0.5\%$ of full scale).
3. Unless otherwise indicated on schematic, voltages taken with negative terminal of voltmeter connected to A7TP2.
4. * Asterisk denotes a factory-selected value. Value shown is typical. Part may be omitted.
5. P/O = Part Of.
6.  Encloses front panel designations.
 Encloses rear panel designation.
7.  Circuit assembly borderline.
 Other assembly borderline.
8.  Numbers in circles on circuit assemblies show locations of test points. Matching numbers are etched on the circuit assemblies.
9.  Encloses wire color code. Code used (MIL-STD-681) is the same as the resistor color code. First number identifies the ground color, second number the wider stripe, and the third number identifies the narrower stripe. E. G., (947) denotes white ground, yellow wide stripe, violet narrow stripe.
10.  Voltage regulator (breakdown) diode.
11.  Power Supply Common (not chassis ground).

Figure 6-2 Schematic Diagram Notes



- | | |
|--------------------------|------------------|
| W1 - Power Cable | W6 - A6 to A8 |
| W2 - A7 to TEST Out | W7 - A8 to DC1 |
| W3 - A6 to REFERENCE Out | W8 - A8 to DC2 |
| W4 - A7 to DC1 | W9 - A9 to A11 |
| W5 - A7 to DC2 | W10 - A10 to A11 |

Figure 6-3. 8745A Component Identification, Top View, Units not Equipped with Rear-Panel Coaxial Link

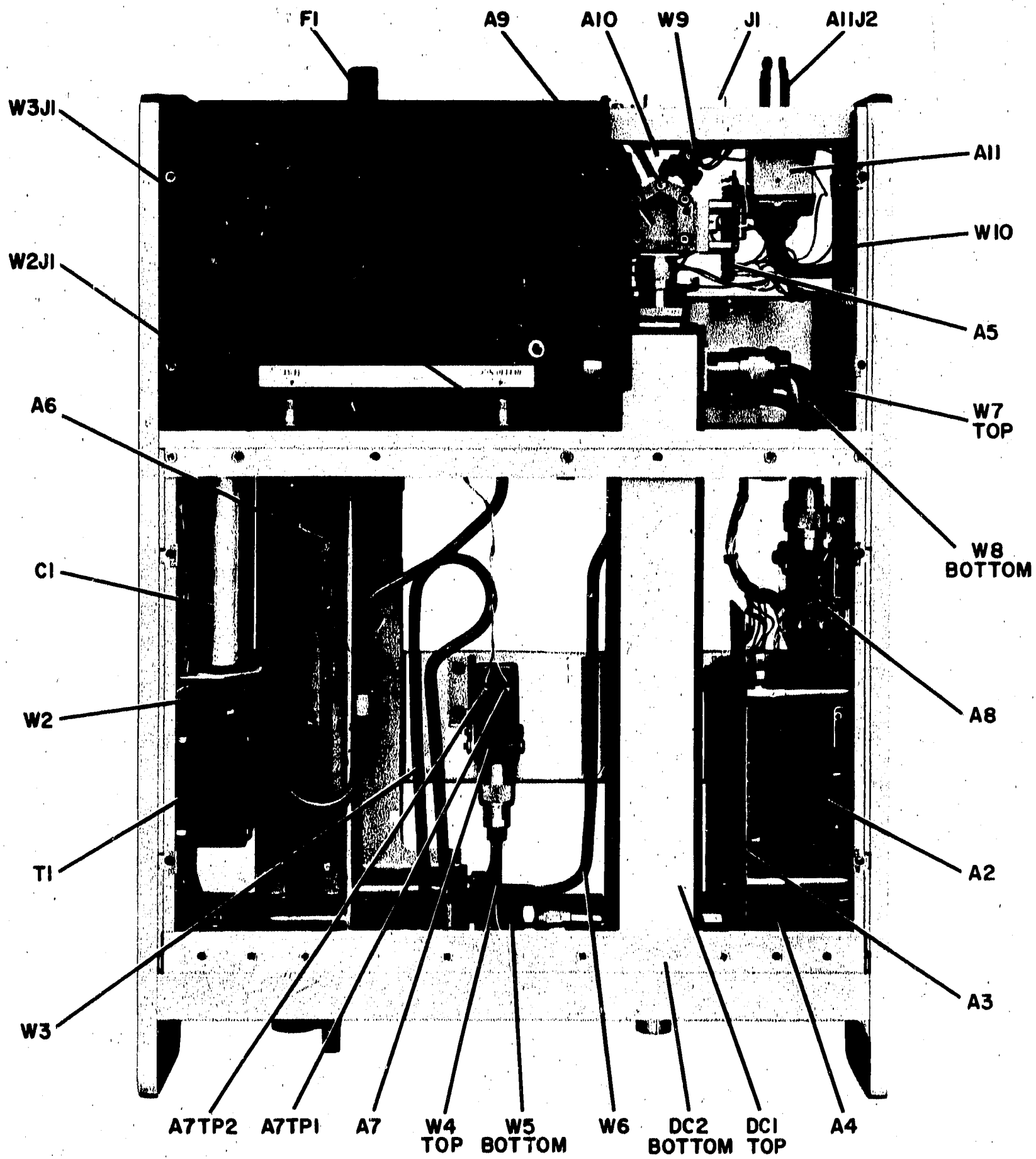
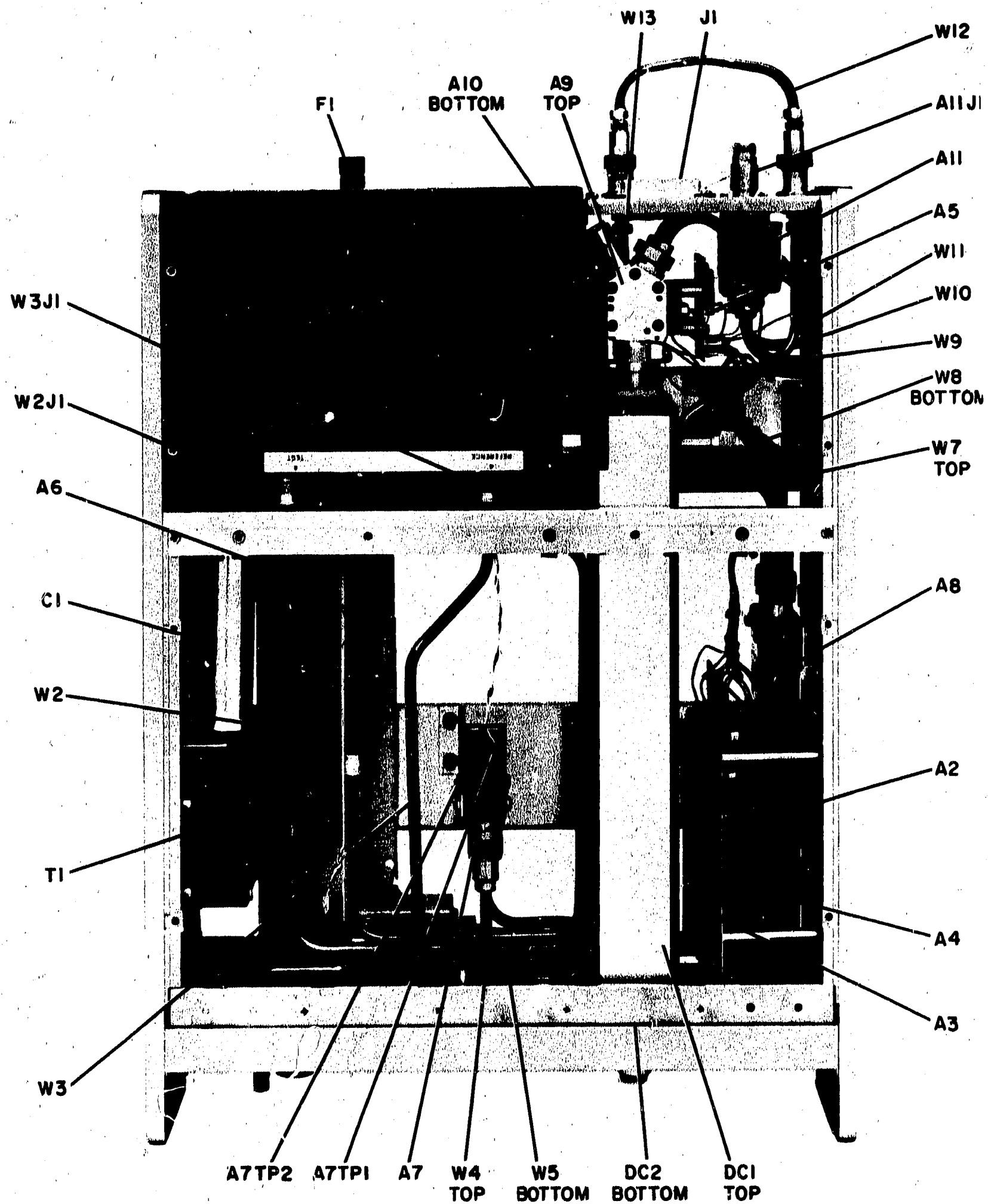

W1 - Power Cable
 W2 - A7 to TEST Out
 W3 - A6 to REFERENCE Out
 W4 - A7 to DC1
 W5 - A7 to DC2
 W6 - Not Assigned
 W7 - A8 to DC1

W8 - A8 to DC2
 W9 - A9 to A11
 W10 - A10 to A11
 W11 - A8 to Rear Panel
 W12 - Rear-Panel Coaxial Link
 W13 - Rear Panel to A6

Figure 6-4. 8745A Component Identification, Top View, Units Equipped with Rear-Panel Coaxial Link

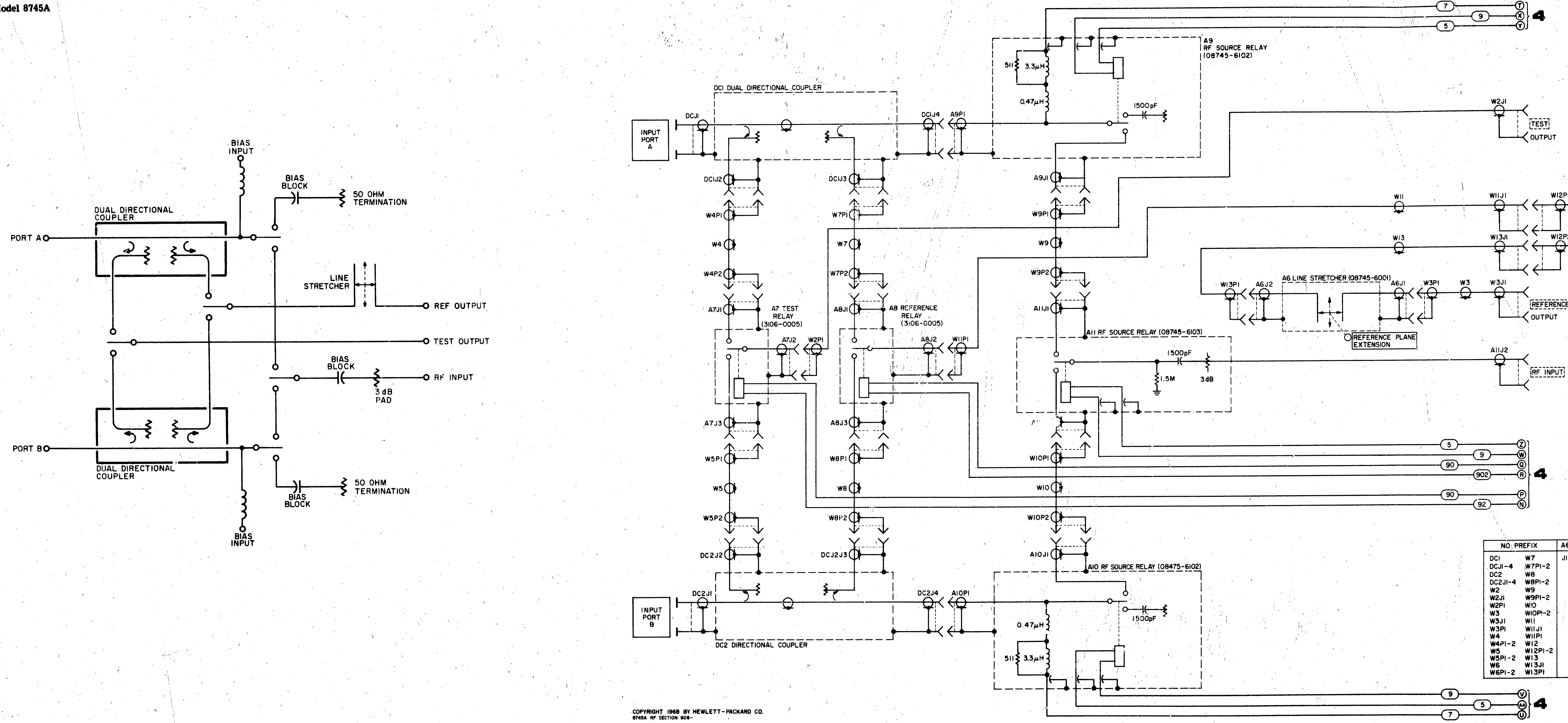

NOTES
 1. SEE FIGURE 6-2 FOR GENERAL NOTES, MEASUREMENT CONDITIONS.
 2. CABLE DETAIL FOR SERIAL NUMBERS PREFIXED 823- W6 REPLACES W11, W12, AND W13.
 3. RELAY SYMBOLS ARE NOT INTENDED TO INDICATE REST POSITIONS OF RELAYS.

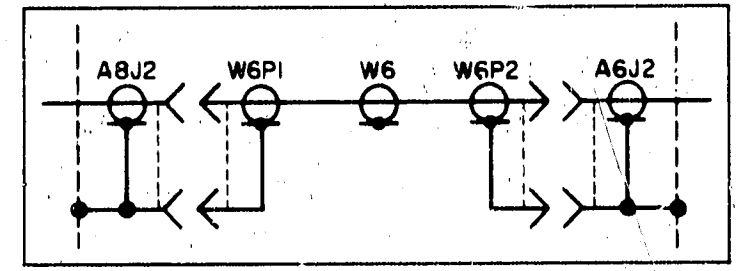

REFERENCE DESIGNATIONS

NO. PREFIX	A6 ASSY	A7 ASSY	A8 ASSY	A9 ASSY	A10 ASSY	A11 ASSY
DC1	W7	J1-2	J1-3	J1-3	J1	J1
DC1-4	W7P1-2				P1	P1
DC2	W8					
DC2J1-4	W8P1-2					
W2	W9					
W2J1	W9P1-2					
W2P1	W10					
W3	W10P1-2					
W3J1	W11					
W3P1	W11J1					
W4	W11P1					
W4P1-2	W12					
W5	W12P1-2					
W5P1-2	W13					
W6	W13J1					
W6P1-2	W13P1					

COPYRIGHT 1968 BY HEWLETT-PACKARD CO.
 8745A RF SECTION 906-

Figure 6-5. Simplified Schematic Diagram, RF Section

Figure 6-6. Schematic Diagram, RF Section

REFERENCE DESIGNATIONS

NO PREFIX		A6 ASSY	A7 ASSY	A8 ASSY	A9 ASSY	A10 ASSY	A11 ASSY
DC1	W7	J1-2	J1-3	J1-3	J1	J1	J1-3
DCJ1-4	W7PI-2				PI	PI	
DC2	W8						
DC2J1-4	W8PI-2						
W2	W3						
W2J1	W9PI-2						
W2PI	W10						
W3	W10PI-2						
W3J1	W11						
W3PI	W11J1						
W4	W11PI						
W4PI-2	W12						
W5	W12PI-2						
W5PI-2	W13						
W6	W13J1						
W6PI-2	W13PI						

Figures 6-5 and 6-6

◀ RF SECTION SCHEMATIC DIAGRAMS

A INVERTERS

When the inputs to the INVERTERS are opened, the outputs are high and their outputs are low. An opening in the main inputs are shorts. The REMOTE CONTROL INVERTER Q15 has three functions: a) when selected it completes the circuit for front panel illumination; b) when out of it disables front panel illumination; and c) sets A-B Flip-Flop to A.

E A-B SELECT FLIP-FLOP

When INPUT POINT A is selected the Flip-Flop outputs are:
A low and A high.

When INPUT POINT B is selected the Flip-Flop outputs are:
A high and A low.

B REMOTE S-PARAMETER DECODER

The REMOTE S-PARAMETER DECODER transmitters are normally shorted. To turn one transmitter on all three of its inputs must be high or open. When a DECODER transmitter is conducting its output is low, causing one of the Latching circuits to latch.

F RELAY DRIVERS

Each Relay Driver has two associated OR-gates and one AND-gate. The output of the AND-gate is high only when both of its inputs are high. To obtain highs from the associated OR-gates at least one input of each OR-gate must also be high.

The Test and Reference Relays are single action spring loaded relays. They require a high input to their Drivers at Q15 and Q17 to energize their coils. When a Driver input is low the Relay will return to its normal state.

The RF Source Relays are double action relays. Their position depends upon the direction of current flow through their coils. The three coils are in parallel and energized simultaneously. When both inputs to the AND-gate are high, Q15 is on and Q17 is on, causing current to flow through the coil in one direction. When one or both of the AND-gate inputs is low or is out of the Q15 coil, causing current to flow through the coil in the opposite direction.

C STEERING DIODES

Diodes Q16, Q17, Q18, Q19, Q20, Q21, and Q22 provide the steering for the Remote S-Parameter Decoder from the Remote S-Parameter Decoder. When a decoder transmitter is conducting its output is low, causing one of the Latching circuits to latch.

D S-PARAMETER LATCHES

The S-Parameter Latches are double action relays. Their position depends upon the direction of current flow through their coils. The three coils are in parallel and energized simultaneously. When both inputs to the AND-gate are high, Q15 is on and Q17 is on, causing current to flow through the coil in one direction. When one or both of the AND-gate inputs is low or is out of the Q15 coil, causing current to flow through the coil in the opposite direction.

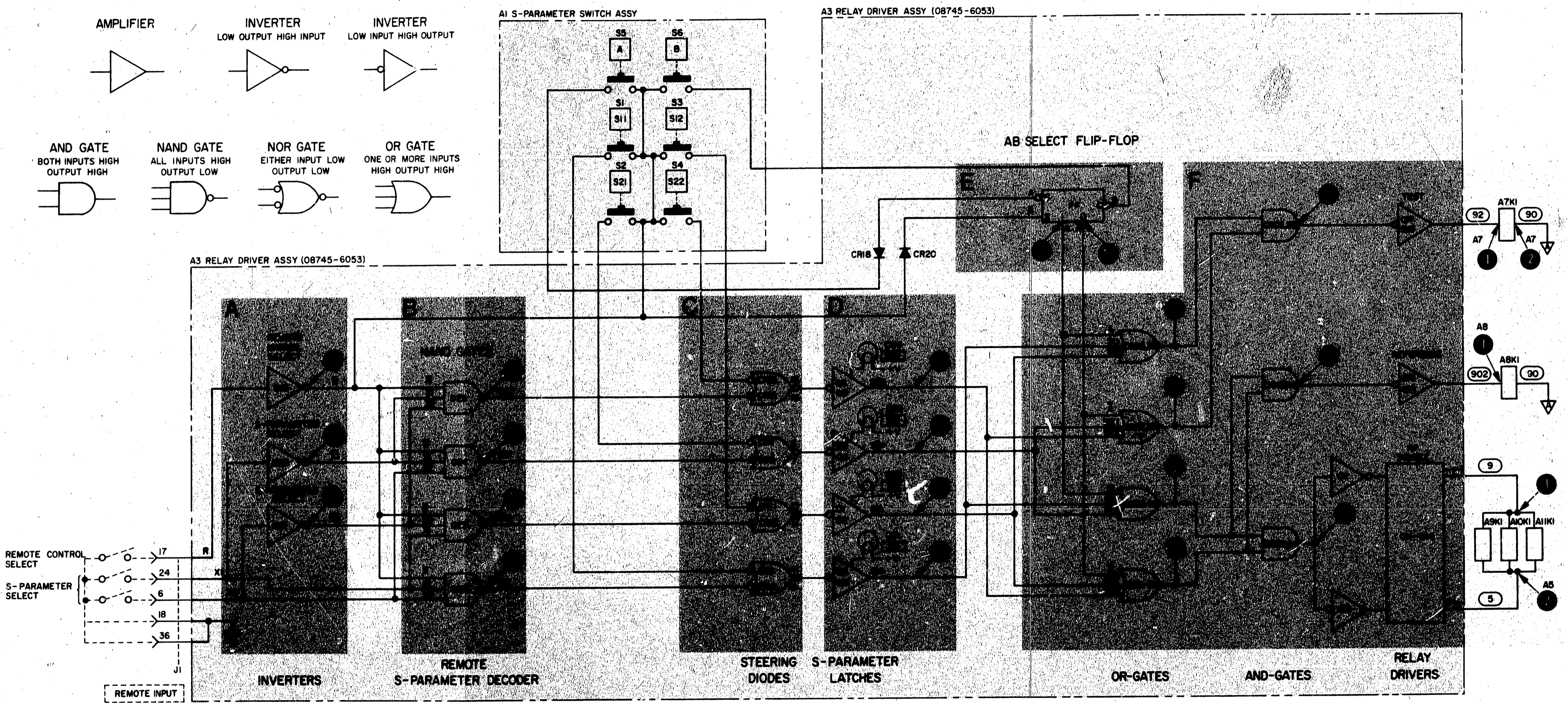

NOTES

- SEE FIGURE 6-2 FOR GENERAL NOTES, MEASUREMENT CONDITIONS.
- LABELS SUCH AS S11 ON THE SIGNAL LINES ARE FOR IDENTIFICATION AND DO NOT SIGNIFY A STATE.

REFERENCE DESIGNATIONS WITHIN OUTLINED ASSEMBLIES ARE ABBREVIATED. FULL DESIGNATION INCLUDES ASSEMBLY NUMBER, e.g. R1 OF ASSEMBLY A1 IS A1R1. DESIGNATIONS OF OTHER COMPONENTS ARE COMPLETE AS SHOWN.

COPYRIGHT 1968 BY HEWLETT-PACKARD CO. RELAY DRIVER ASSY BLOCK DIAGRAM 906-

Figure 6-7. Relay Control Section Circuit Descriptions

Figure 6-8. Block Diagram, Relay Control Section

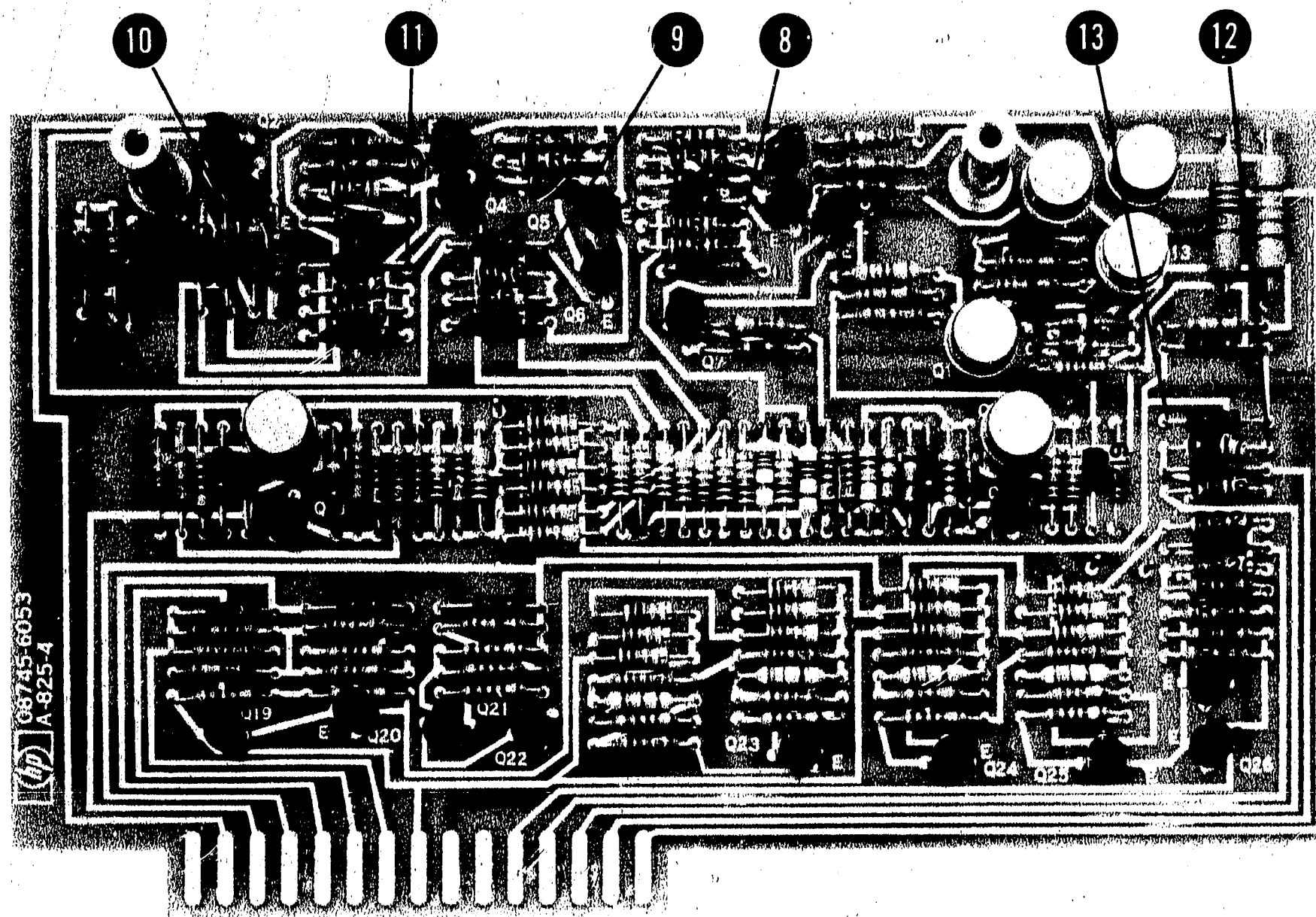

Figure 6-9. A3 Relay Driver Assembly Component Identification for S-Parameter Latches
Serial Numbers Prefixed 823-

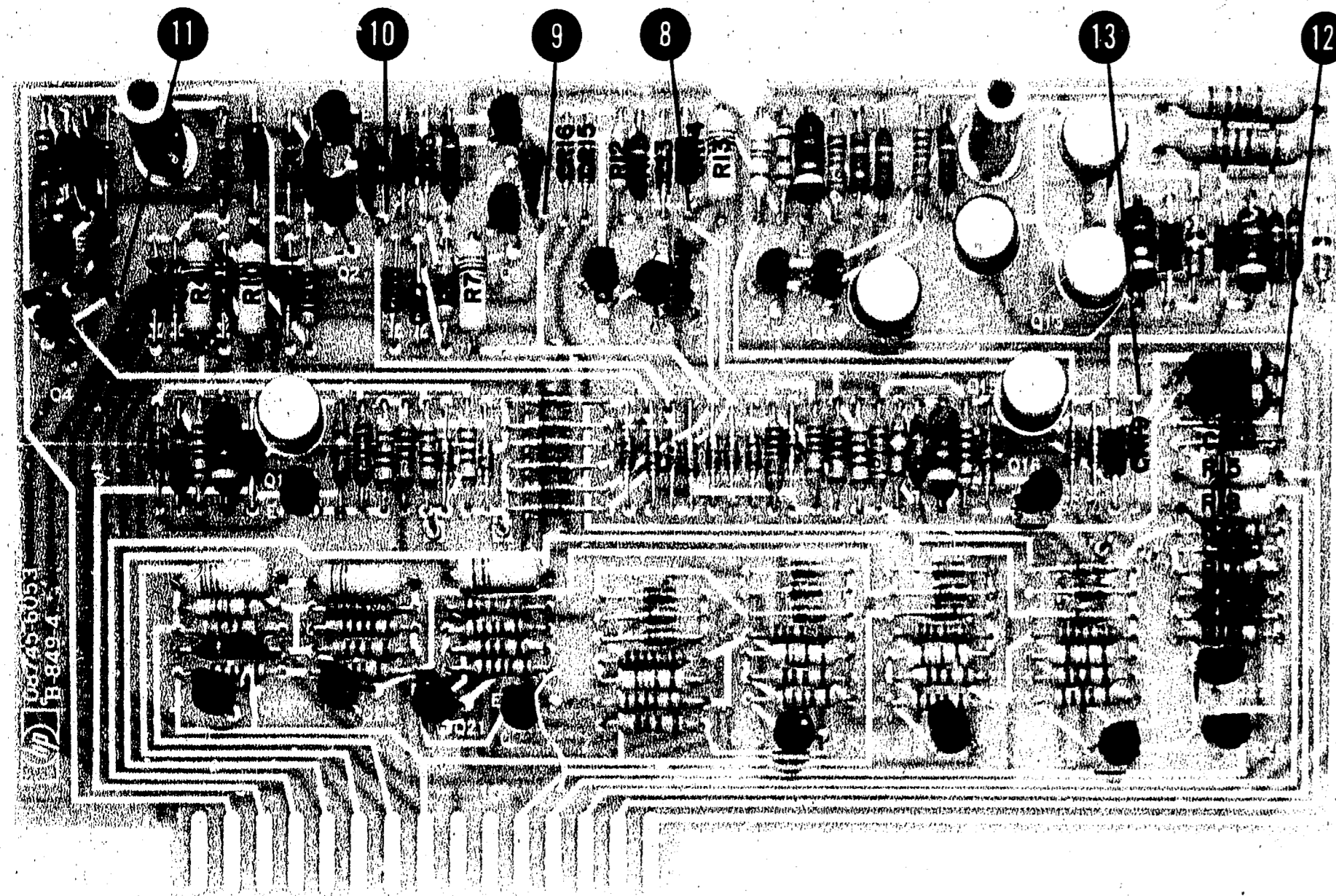
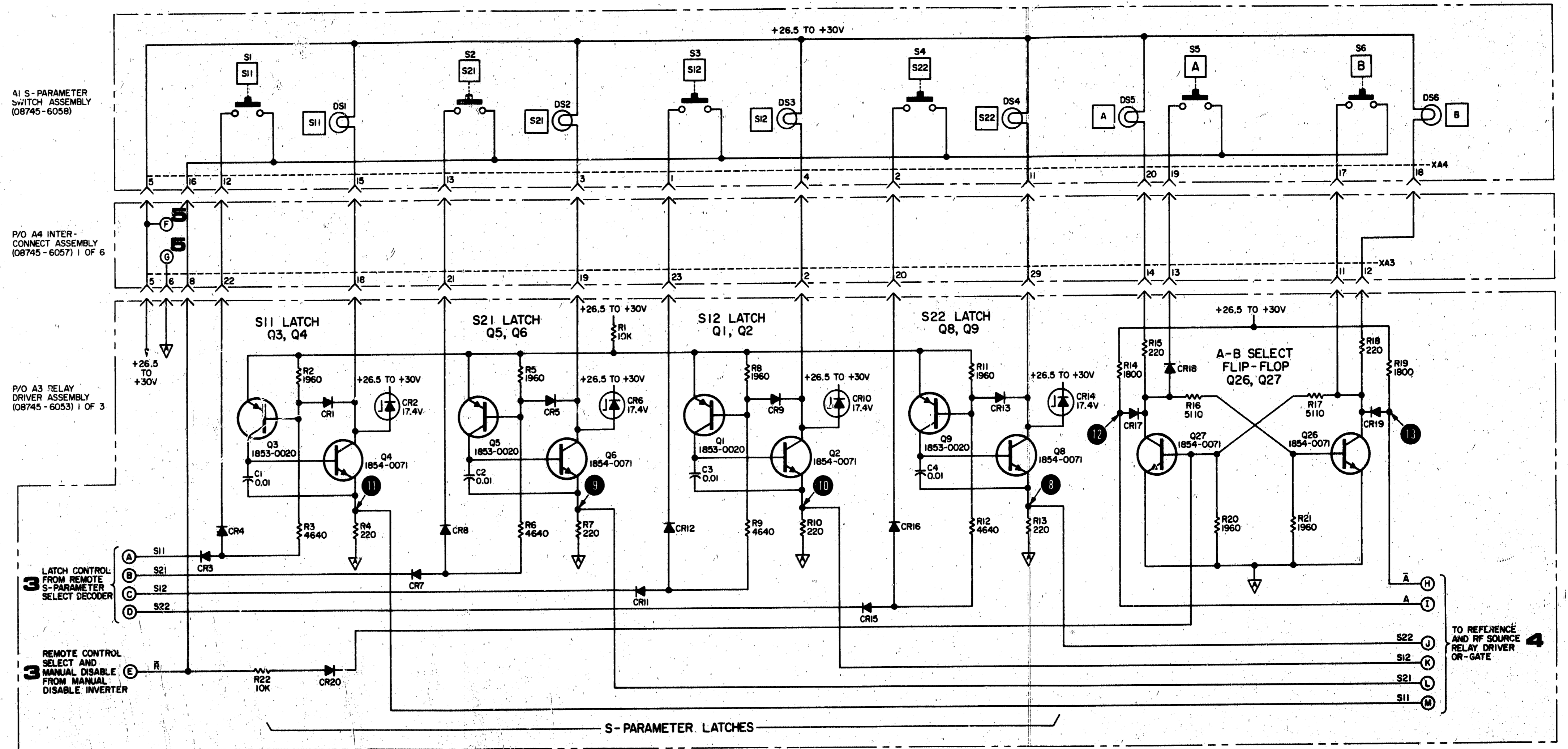

Figure 6-10. A3 Relay Driver Assembly Component Identification for S-Parameter Latches Serial Numbers Prefix:ed 906- and Above

Table 6-1. Test Point Voltages for S-Parameter Latches

CONDITION		TEST POINT VOLTAGE (with respect to A7TP2)						
INPUT PORT SELECTED	S-PARAMETER SELECTED	A3 TP8	A3 TP9	A3 TP10	A3 TP11	A3 TP12	A3 TP13	
A	S ₁₁	<0.5V	<0.5V	<0.5V	10.5V	1.0V	9.4V	
	S ₂₁	<0.5V	10.5V	<0.5V	<0.5V	1.0V	10.4V	
	S ₁₂	<0.5V	<0.5V	10.5V	<0.5V	1.0V	10.8V	
	S ₂₂	11V	<0.5V	<0.5V	<0.5V	1.0V	10.9V	
B	S ₁₁	<0.5V	<0.5V	<0.5V	10.8V	11.0V	0.8V	
	S ₂₁	<0.5V	10.5V	<0.5V	<0.5V	10.5V	0.8V	
	S ₁₂	<0.5V	<0.5V	10.6V	<0.5V	10.5V	0.8V	
	S ₂₂	10.5V	<0.5V	<0.5V	<0.5V	9.4V	0.8V	
REMOTE OPERATION	J1, 6	J1, 24						
	O	O	<0.5V	<0.5V	<0.5V	8.6V	1.0V	9.4V
J1 Pin 17 shorted to Pin 18 or Pin 36	O	s	<0.5V	9.0V	<0.5V	<0.5V	1.0V	9.4V
	s	O	<0.5V	<0.5V	8.5V	<0.5V	1.0V	9.4V
	s	s	9.0V	<0.5V	<0.5V	<0.5V	1.0V	9.4V
	s	s	<0.5V	<0.5V	<0.5V	<0.5V	1.0V	9.4V

O = Open s = Shorted to J1 Pin 18 or Pin 36.



NO PREFIX	A1 ASSY	A3 ASSY	A4 ASSY
	DS1-6 SI-6 XA4	CI-4 CR1-20 Q1-5, 8, 9, 26, 27 RI-22	XA3

REFERENCE DESIGNATIONS WITHIN OUTLINED (---) ASSEMBLIES ARE ABBREVIATED. FULL DESIGNATION INCLUDES ASSEMBLY NUMBER, e.g., RI OF ASSEMBLY A1 IS A1R1. DESIGNATIONS OF OTHER COMPONENTS ARE COMPLETE AS SHOWN.

NOTES
SEE FIG. 6-2 FOR GENERAL NOTES, MEASUREMENT CONDITIONS

COPYRIGHT 1968 BY HEWLETT PACKARD CO.
8745A S-PARAMETER SWITCH ASSY AND P/O RELAY DRIVER (1 OF 3) 906-

Figure 6-11. Relay Control Section Schematic Diagram, S-Parameter Selectors and Latching Circuits

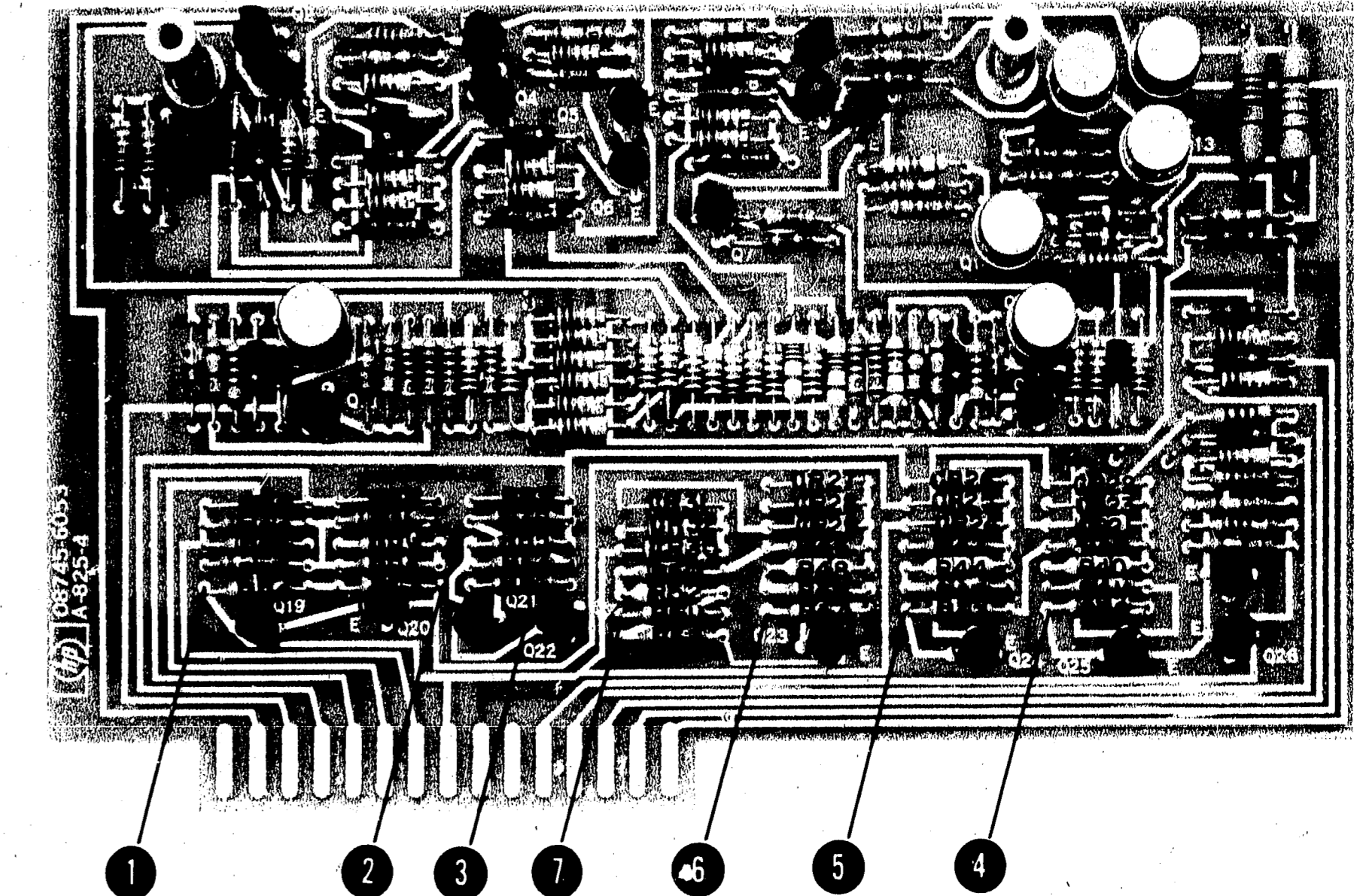

Figure 6-12. A3 Relay Driver Assembly Component Identification for Inverters and Remote S-Parameter Select Decoder
Serial Numbers Prefixed 823-

REFERENCE DESIGNATIONS			
NO PREFIX	A1 ASSY	A3 ASSY	A4 ASSY
	DSI-6	CI-4	XA3
	SI-6	CRI-20	
	XA4	QI-6,8,9,26, 27	
		RI-22	

Figures 6-9, 6-10 and 6-11
Table 6-1

◀ **RELAY CONTROL SECTION**
S-PARAMETER SELECTORS
LATCHING CIRCUITS

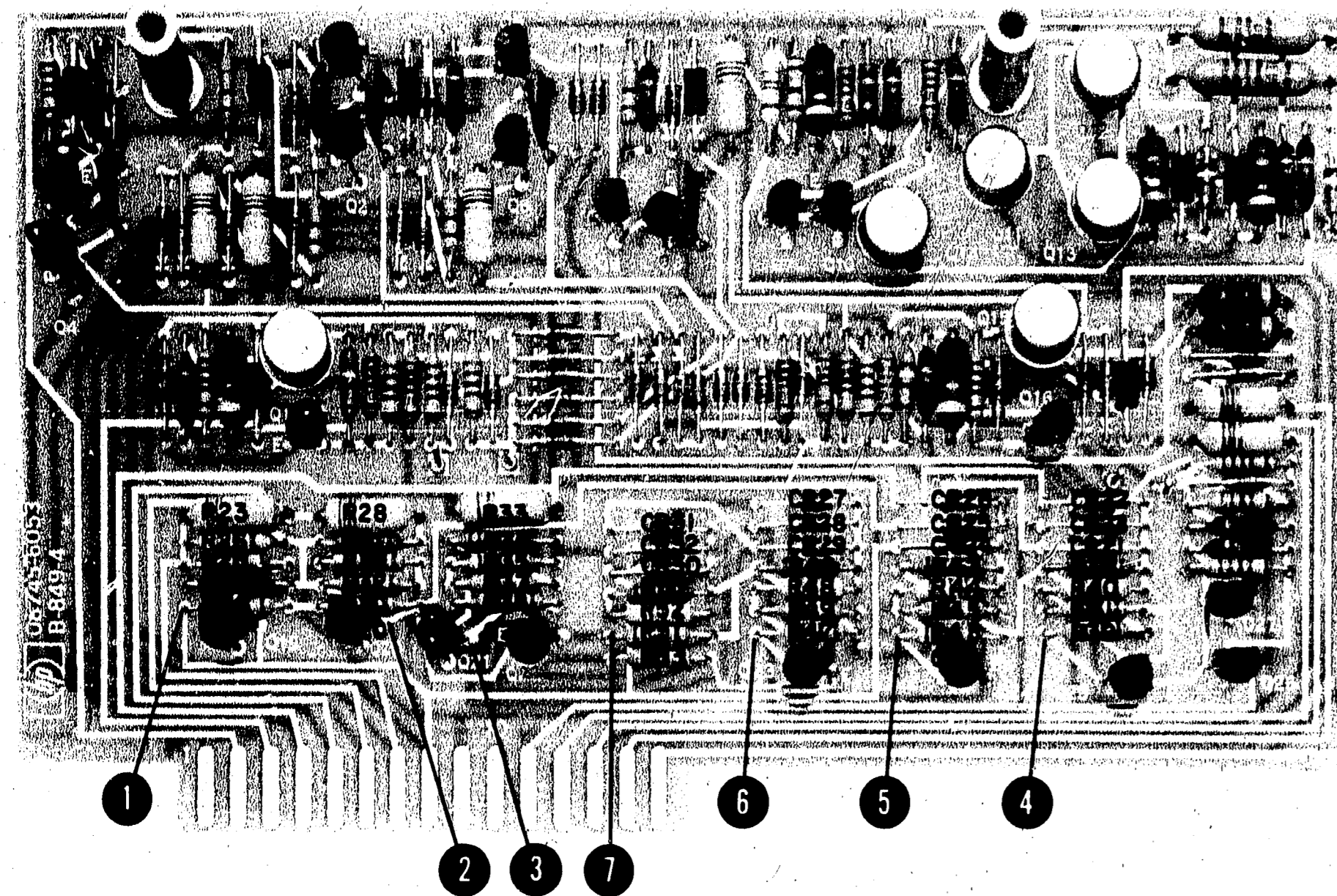
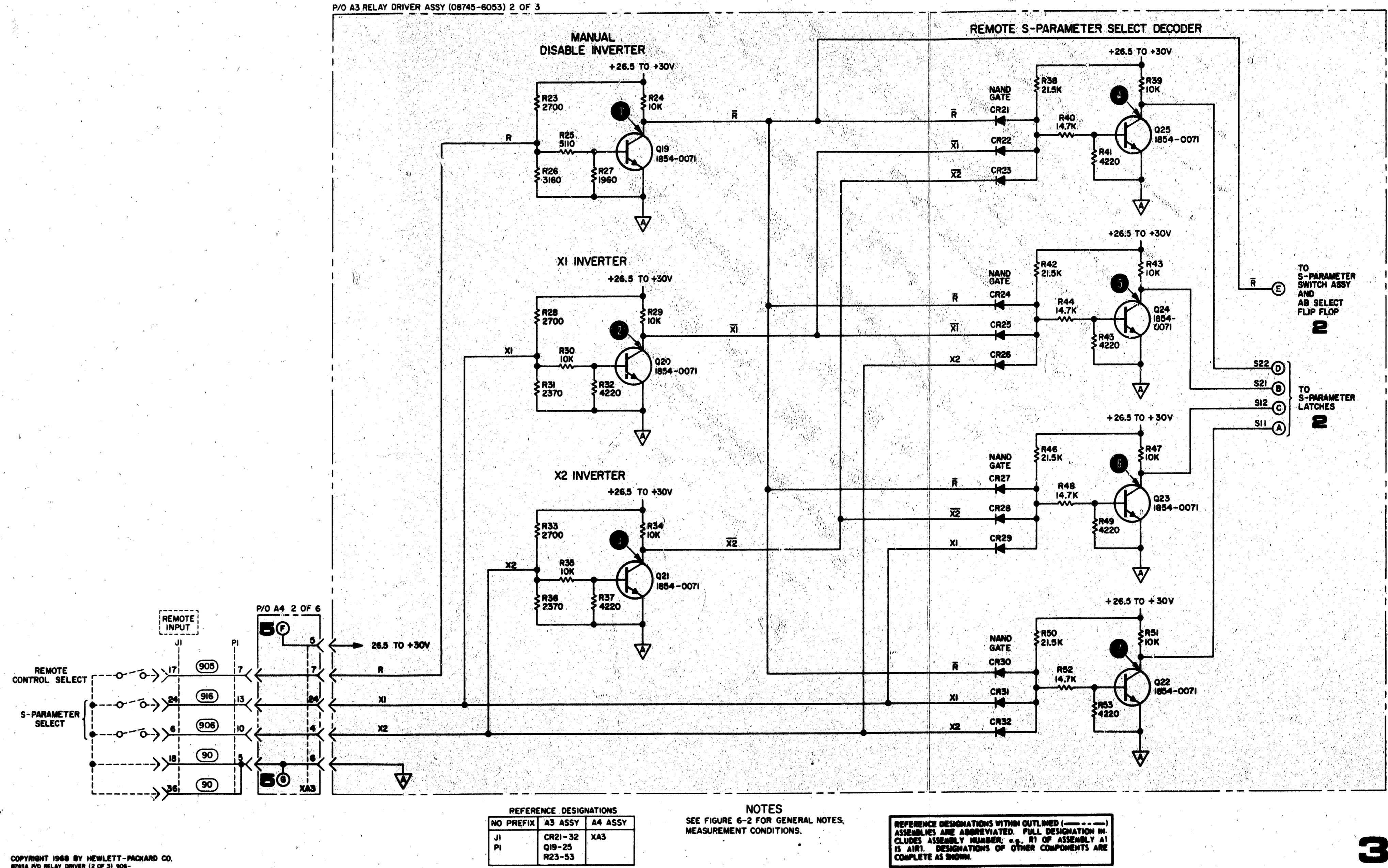

Figure 6-13. A3 Relay Driver Assembly Component Identification for Inverters and Remote S-Parameter Select Decoder
Serial Numbers Prefixed 906- and Above

Table 6-2. Test Point Voltages for Inverters and Remote S-Parameter Select Decoder

CONDITION		TEST POINT VOLTAGE (with respect to A7TP2)						
INPUT PORT SELECTED	S-PARAMETER SELECTED	A3 TP1	A3 TP2	A3 TP3	A3 TP4	A3 TP5	A3 TP6	A3 TP7
A	S ₁₁	< 0.5V	< 0.5V	< 0.5V	> 26V	> 26V	> 26V	> 26V
	S ₂₁	↓	↓	↓	↓	↓	↓	↓
	S ₁₂	↓	↓	↓	↓	↓	↓	↓
	S ₂₂	↓	↓	↓	↓	↓	↓	↓
B	S ₁₁	< 0.5V	< 0.5V	< 0.5V	> 26V	> 26V	> 26V	> 26V
	S ₂₁	↓	↓	↓	↓	↓	↓	↓
	S ₁₂	↓	↓	↓	↓	↓	↓	↓
	S ₂₂	↓	↓	↓	↓	↓	↓	↓
REMOTE OPERATION		J1, 6	J1, 24					
J1 Pin 17 shorted to Pin 18 or Pin 36	O	O	15V	< 0.5V	< 0.5V	> 26V	> 26V	> 26V
	O	s	15V	> 26V	< 0.5V	> 26V	< 0.5V	> 26V
	s	O	15V	< 0.5V	> 26V	> 26V	> 26V	< 0.5V
	s	s	15V	> 26V	> 26V	< 0.5V	> 26V	> 26V

O = Open s = Shorted to J1 Pin 18 or Pin 36.



COPYRIGHT 1968 BY HEWLETT-PACKARD CO.
8745A P/O RELAY DRIVER (2 OF 3) 906-

Figure 6-14. Relay Control Section Schematic Diagram, Inverters, and Remote S-Parameter Select Decoder

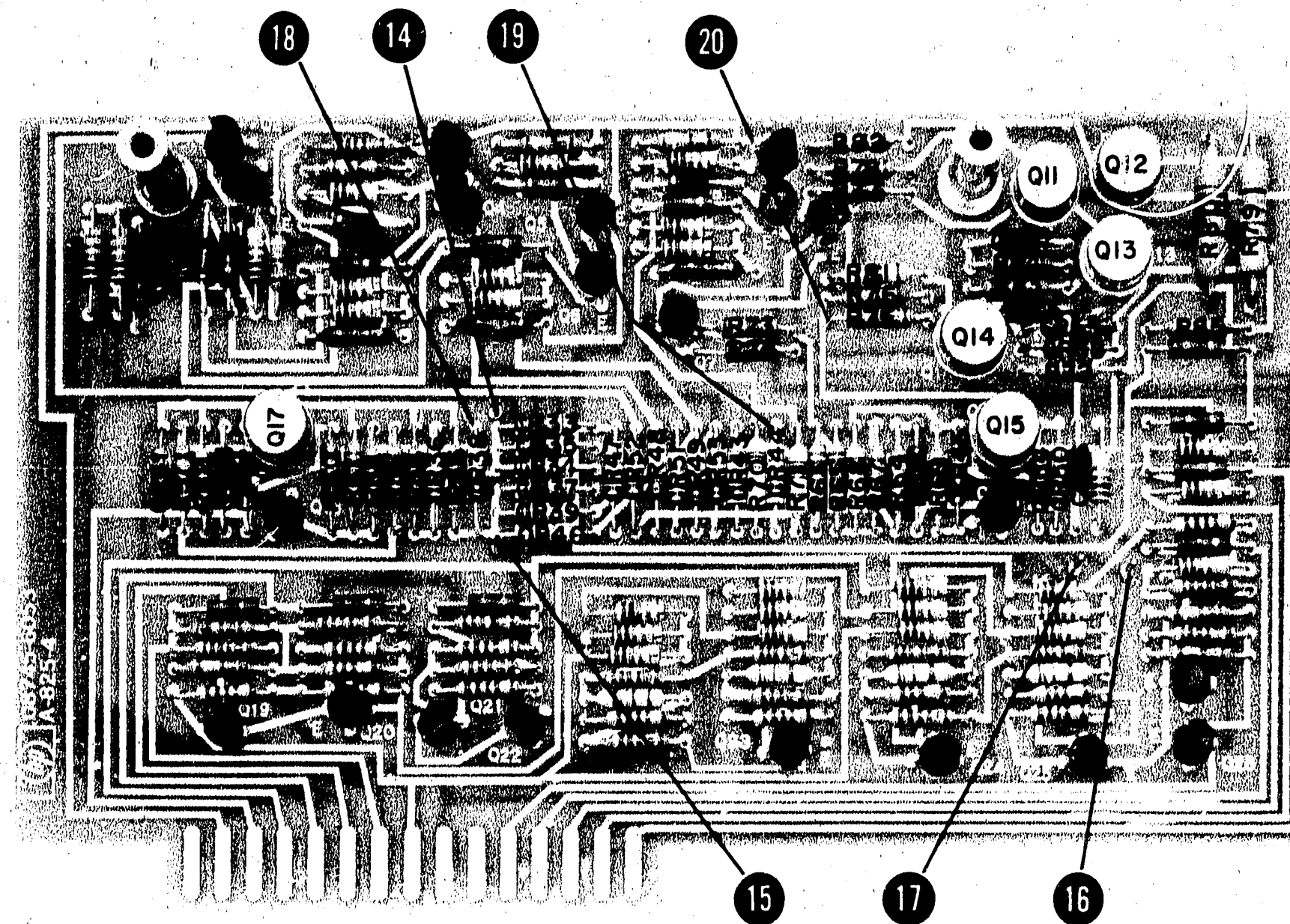

Figure 6-15. A3 Relay Driver Assembly Component Identification for OR-Gate, AND-Gate and Relay Drivers
Serial Numbers Prefixed 823-

REFERENCE DESIGNATIONS

NO PREFIX	A3 ASSY	A4 ASSY
J1	CR21-32	XA3
P1	Q19-25	
	R23-53	

Figures 6-12, 6-13 and 6-14
Table 6-2

◀ **RELAY CONTROL SECTION**

INVERTERS

REMOTE S-PARAMETER SELECT DECODER

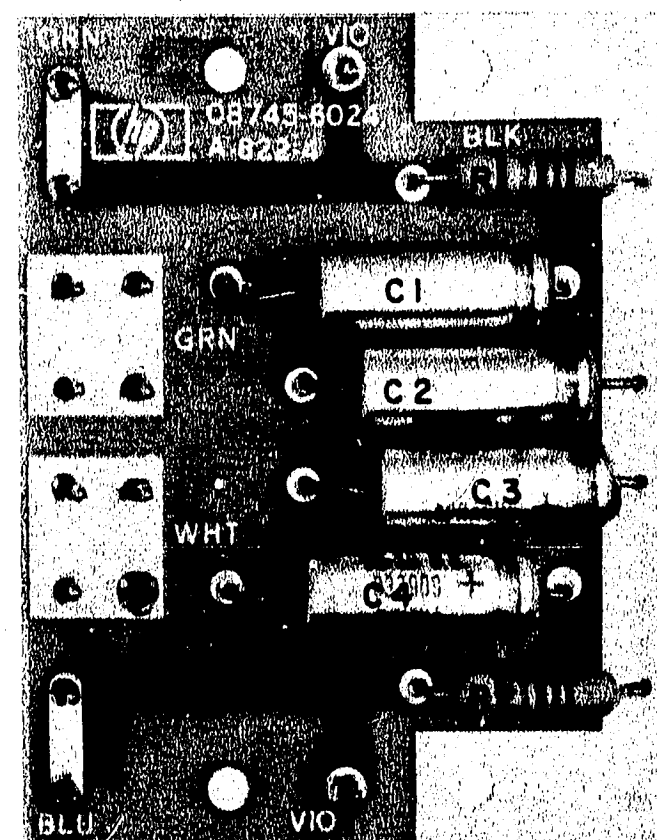

Figure 6-16. A5 Bias Filter Assembly
Component Identification
Serial Numbers Prefixed 823-

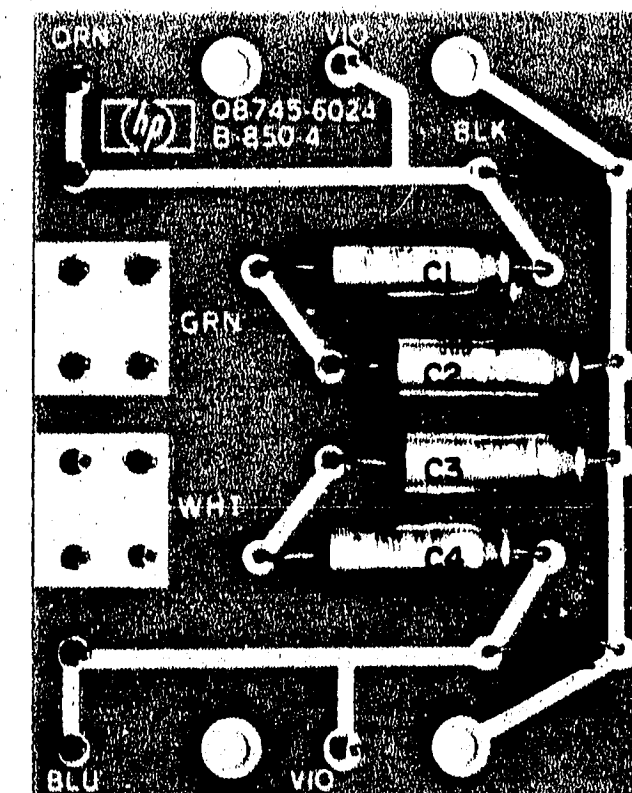

Figure 6-17. A5 Bias Filter Assembly
Component Identification
Serial Numbers Prefixed 906- and Above

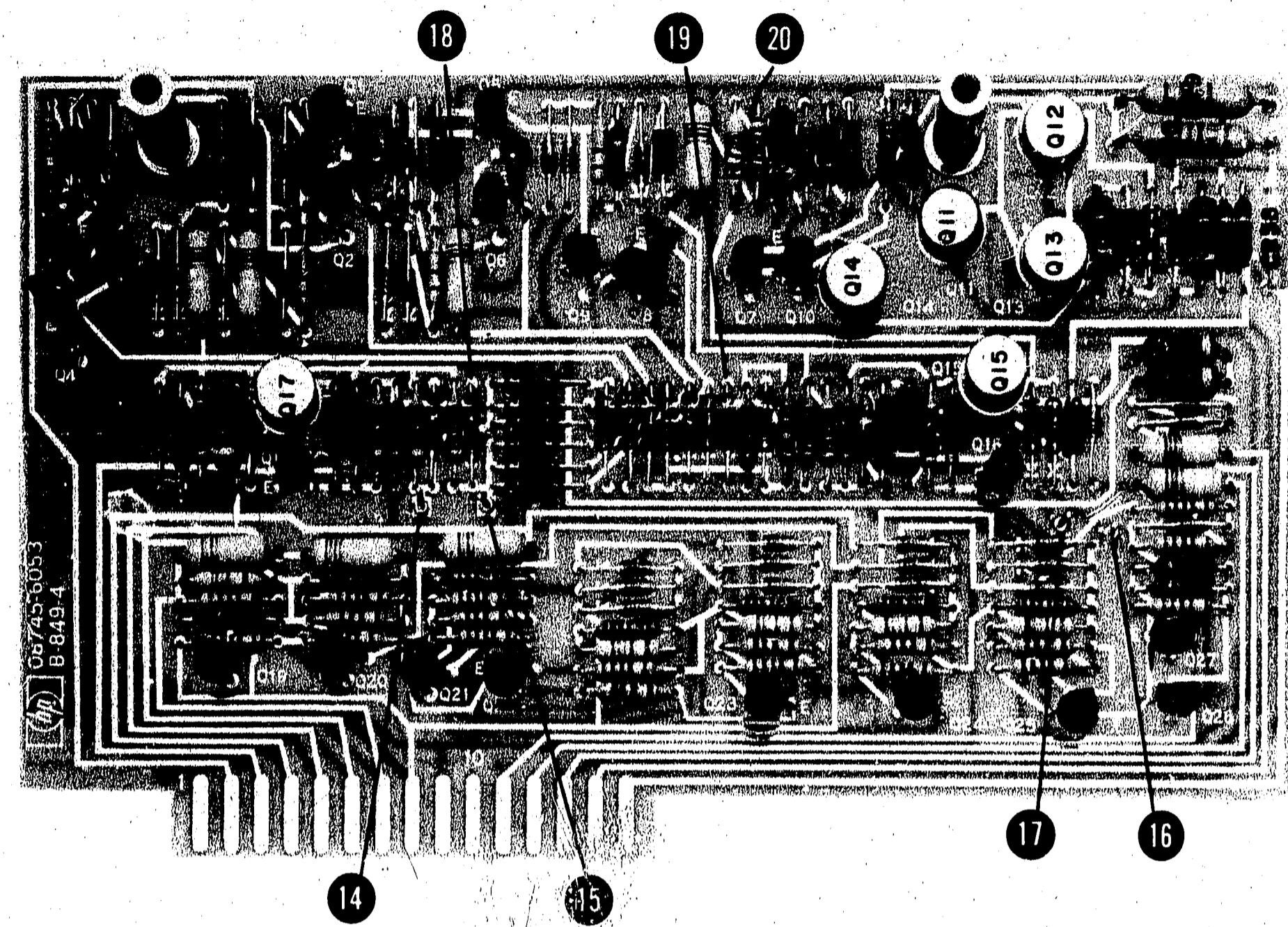
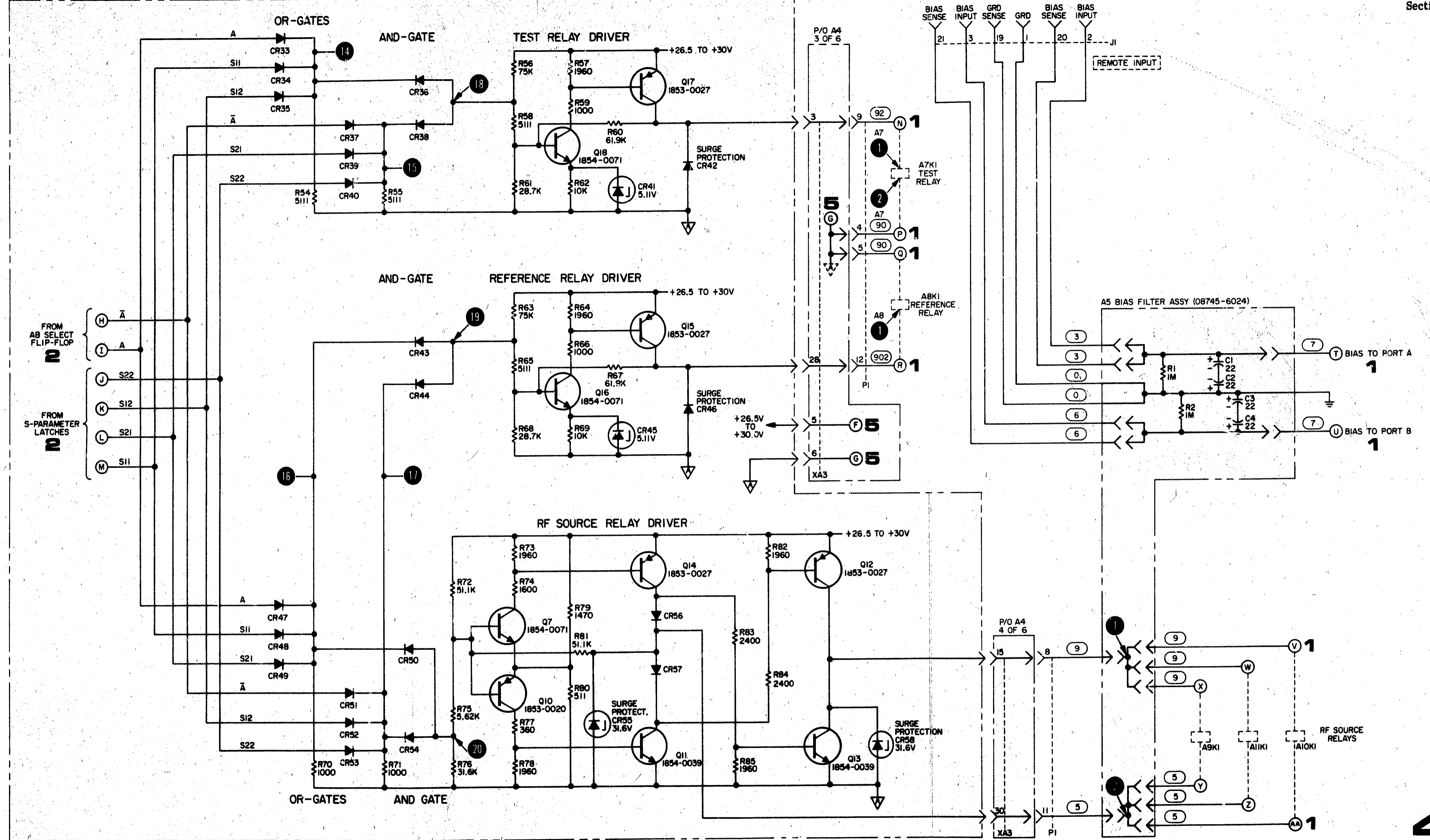

Figure 6-18. A3 Relay Driver Assembly Component Identification for OR-Gate, AND-Gate and Relay Drivers Serial Numbers Prefixed 906- and Above

Table 6-3. Test Point Voltages for OR-Gate, AND-Gate, and Relay Drivers

CONDITION		TEST POINT VOLTAGE (with respect to A7TP2)													
INPUT PORT SELECTED	S-PARAMETER SELECTED	A3 TP14	A3 TP15	A3 TP16	A3 TP17	A3 TP18	A3 TP19	A3 TP20	A5 TP1	A5 TP2	A7 TP1	A8 TP1			
A	S ₁₁	10V	9.0V	9.8V	8.7V	7.0V	7.0V	9.2V	<0.5V	>26V	>26V	>26V			
	S ₂₁	1.5V	10.0V	9.8V	9.7V	2.0V	7.0V	10.0V	<0.5V	>26V	<0.5V	>26V			
	S ₁₂	10.0V	10.0V	1.0V	10.1V	7.0V	1.5V	1.5V	>26V	1.0V	>26V	<0.5V			
	S ₂₂	1.5V	10.0V	1.0V	10.2V	2.0V	1.5V	1.5V	>26V	1.0V	<0.5V	<0.5V			
B	S ₁₁	10.0V	1.5V	10.2V	1.0V	2.0V	1.5V	1.5V	>26V	1.0V	<0.5V	<0.5V			
	S ₂₁	10.0V	10.0V	10.0V	1.0V	7.0V	1.5V	1.5V	>26V	1.0V	>26V	<0.5V			
	S ₁₂	10.0V	1.5V	9.8V	10.0V	2.0V	7.0V	10.0V	<0.5V	>26V	<0.5V	>26V			
	S ₂₂	8.8V	10.0V	8.7V	9.8V	7.0V	7.0V	9.2V	<0.5V	>26V	>26V	>26V			
REMOTE OPERATION	J1, 6	J1, 24													
J1 Pin 17 shorted to Pin 18 or Pin 36	O	O	8.1V	8.8V	8.0V	8.6V	7.0V	7.0V	8.8V	<0.5V	>26V	>26V	>26V		
	O	s	1.5V	8.8V	8.0V	8.6V	2.0V	7.0V	8.8V	<0.5V	>26V	<0.5V	>26V		
	s	O	8.0V	8.8V	1.0V	8.8V	7.0V	1.5V	1.5V	>26V	1.0V	>26V	<0.5V		
	s	s	1.5V	8.8V	1.0V	8.8V	2.0V	1.5V	1.5V	>26V	1.0V	<0.5V	<0.5V		
O = Open		s = Shorted to J1 Pin 18 or Pin 36.													



COPYRIGHT 1968 BY HEWLETT-PACKARD CO. 8745A P/O RELAY DRIVER (3 OF 3) 906-

REFERENCE DESIGNATIONS WITHIN OUTLINED (---) ASSEMBLIES ARE ABBREVIATED. FULL DESIGNATION INCLUDES ASSEMBLY NUMBER, e.g., R1 OF ASSEMBLY A1 IS A1R1. DESIGNATIONS OF OTHER COMPONENTS ARE COMPLETE AS SHOWN.

NO PREFIX	A3 ASSY	A4 ASSY	A5 ASSY
J1	CR33-58	XA2	CI-4
P1	Q7, IO-18	XA3	RI, 2
	RS4-85		

- NOTES
- SEE FIGURE 6-2 FOR GENERAL NOTES, MEASUREMENT CONDITIONS.
 - IF A3Q11, A3Q12, A3Q13, OR A3Q14 FAILS REPLACE ALL FOUR TRANSISTORS BEFORE APPLYING POWER TO THE 8745A.

Figure 6-19. Relay Control Section Schematic Diagram, Relay Drivers, RF Relays and Bias Filter

REFERENCE DESIGNATIONS			
NO PREFIX	A3 ASSY	A4 ASSY	A5 ASSY
J1	CR33-58	XA2	CI-4
P1	Q7, 10-18	XA3	RI, 2
	R54-85		

Figures 6-15, 6-16, 6-17, 6-18 and 6-19
Table 6-3

◀ **RELAY CONTROL SECTION**

RELAY DRIVERS

RF RELAYS

BIAS FILTER

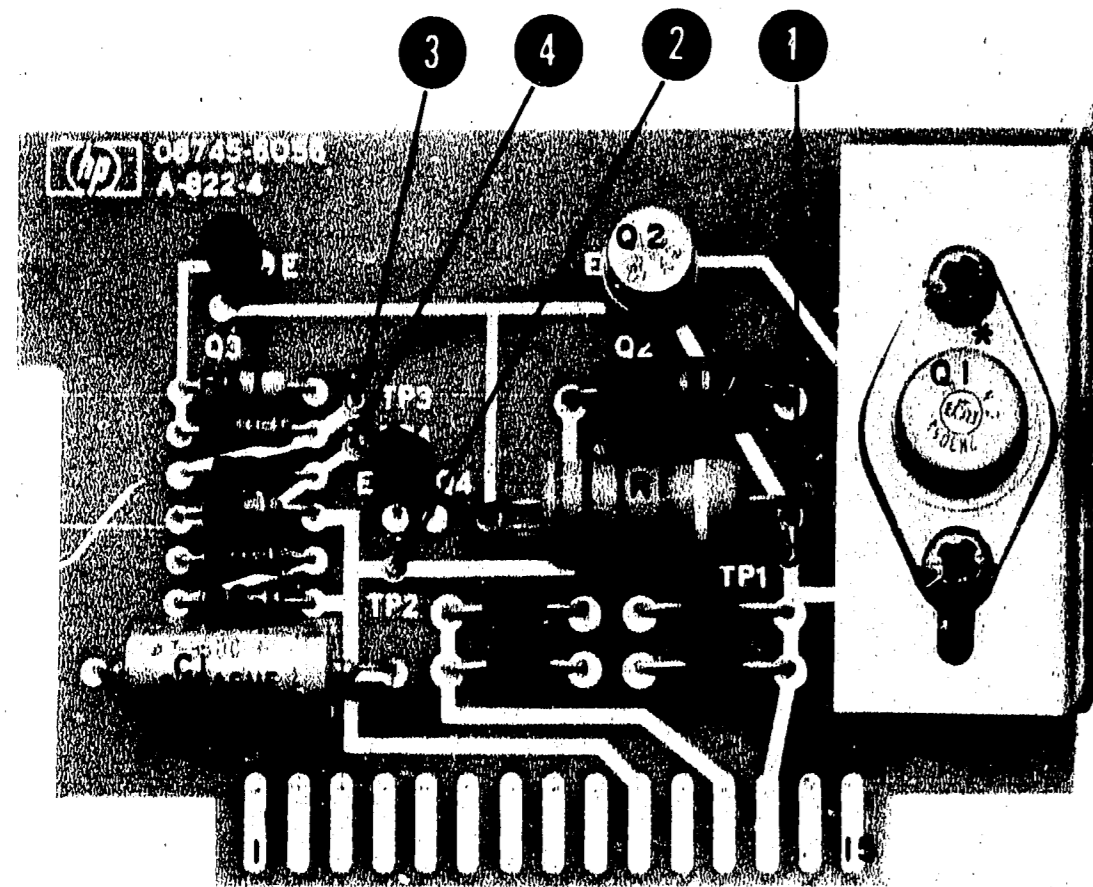

* CHASSIS PART, NOT PART OF A2.

Figure 6-20. A2 Power Supply Assembly Component Identification

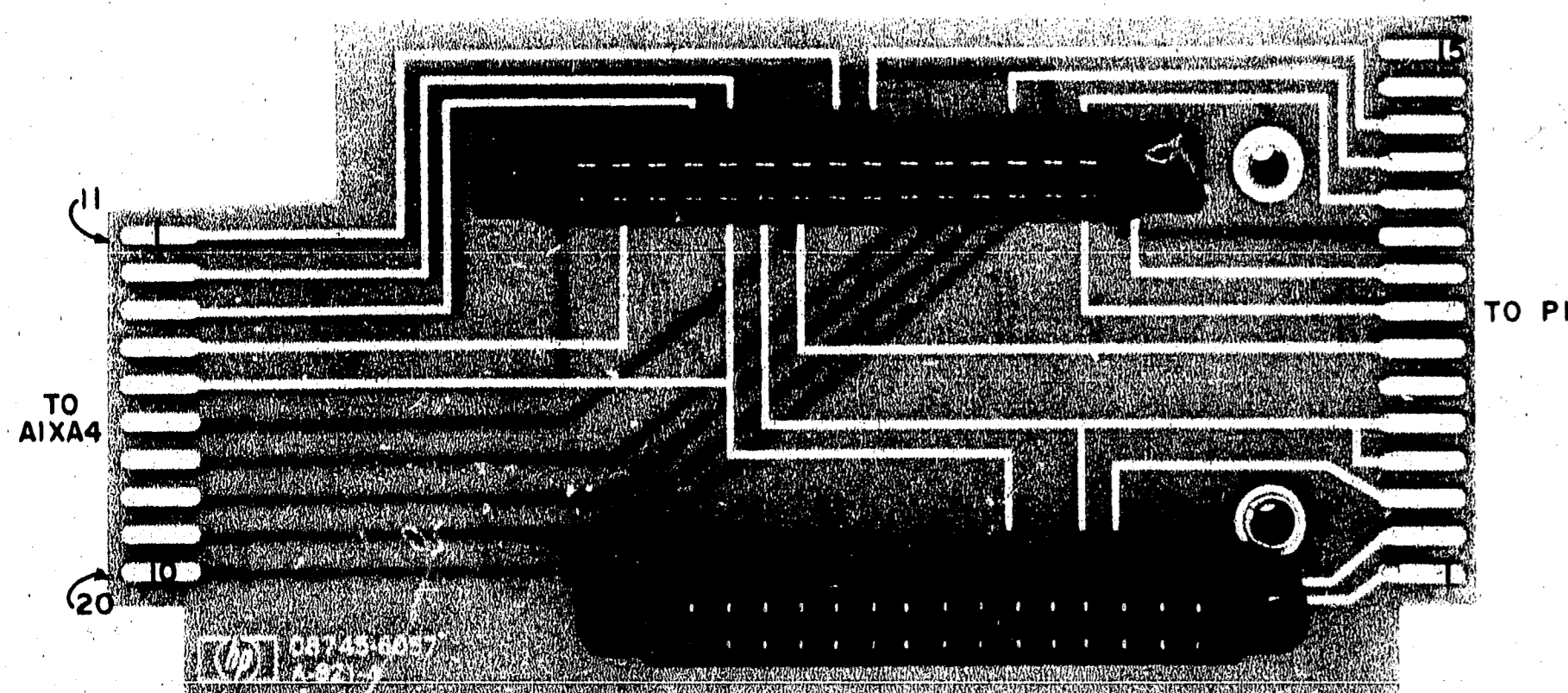

Figure 6-21. A4 Interconnect Assembly Component Identification

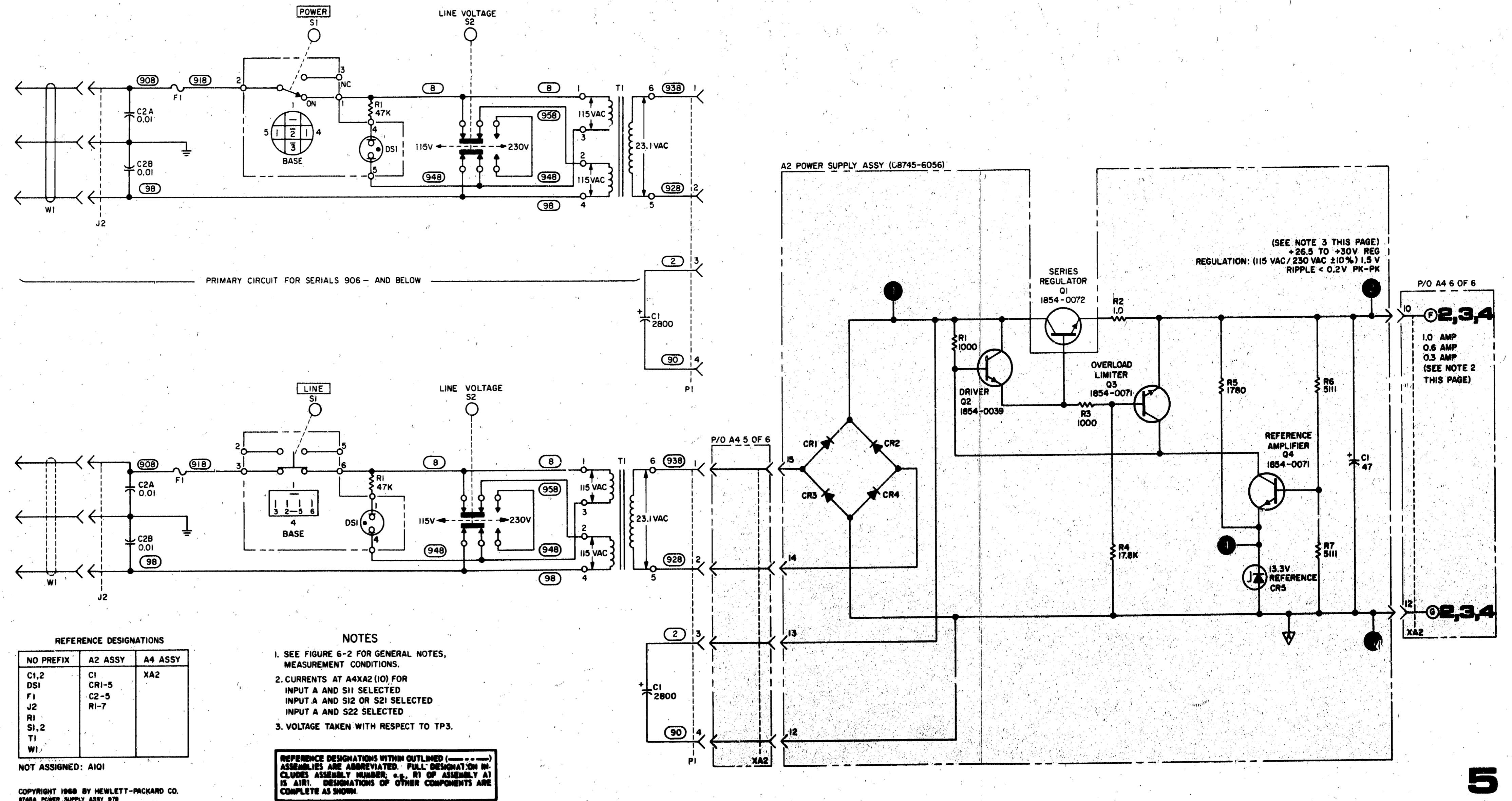

Figure 6-22. Relay Control Section Schematic Diagram, Power Supply

REFERENCE DESIGNATIONS

NO PREFIX	A2 ASSY	A4 ASSY
C1,2	C1	XA2
DSI	C1-5	
F1	C2-5	
J2	R1-7	
R1		
SI,2		
TI		
WI		

NOT ASSIGNED: A101

Figures 6-20, 6-21 and 6-22

◀ **RELAY CONTROL SECTION**
POWER SUPPLY

APPENDIX

APPENDIX I MANUAL CHANGES

To adapt this manual to instruments with Serial Numbers listed in the table below, make the indicated manual changes.

Information for adapting this manual to instruments with Serial Numbers not listed in the table below may be included in a yellow MANUAL CHANGES insert supplied with this manual. Information about Serial Numbers not covered in any of these ways can be obtained from the nearest Hewlett-Packard office.

SERIAL PREFIX OR NUMBER	MAKE MANUAL CHANGES	SERIAL PREFIX OR NUMBER	MAKE MANUAL CHANGES
823-	A, B		
906-	B		

CHANGE A:

The main difference between instruments with serial numbers prefixed 823 and those with serial numbers prefixed 906 is that those with the 906 prefix have a removable coaxial link on the rear panel. All differences pertaining to this link are noted where they apply throughout the manual. All other differences are noted below:

Page 5-2, Table 5-1:

Delete A3C1 thru A3C4.

Page 5-4, Table 5-1:

Change A3R4, A3R7, A3R10, A3R13, and A3R15 to HP Part No. 0683-2215, R: FXD COMP 220 OHM 5% 1/4W.

Change A3R14 to HP Part No. 0683-1825, R: FXD COMP 1800 OHM 5% 1/4W.

Page 5-5, Table 5-1:

Change A3R18 to HP Part No. 0683-2215, R: FXD COMP 220 OHM 5% 1/4W.

Change A3R19 to HP Part No. 0683-1825, R: FXD COMP 1800 OHM 5% 1/4W.

Change A3R23, A3R28, and A3R33 to HP Part No. 0683-2725, R: FXD COMP 2700 OHM 5% 1/4W.

Change A3R59 to HP Part No. 0683-1025, R: FXD COMP 1000 OHM 5% 1/4W.

Page 5-6, Table 5-1:

Change A3R66 to HP Part No. 0683-1025, R: FXD COMP 1000 OHM 5% 1/4W.

Change A3R74 to HP Part No. 0683-1625, R: FXD COMP 1600 OHM 5% 1/4W.

Change A3R83 and A3R84 to HP Part No. 0698-3150, R: FXD MET FLM 2.37K OHM 1% 1/8W.

Change A5C1 thru A5C4 to HP Part No. 0180-0049, C: FXD AL ELEC 20 μ F 50 VDCW.

Change A5R1 and A5R2 to HP Part No. 0757-0059, R: FXD MET FLM 1 MEGOHM 1% 1/2W.

Page 5-7, Table 5-1:

Change W2 to HP Part No. 08745-2037, ASSY: CABLE TEST OUT TO A7.

Add W6 HP Part No. 08745-2039, CABLE ASSY: A6 to A8.

Delete W11, W12, and W13.

**CHANGE A: Page 5-12, Table 5-2:
(Cont'd)**

Delete HP Part No. 0150-0093.

Change HP Part No. 0180-2210 to 0180-0049, C: FXD AL ELECT 20 μ F 50 VDCW, Mfr. 56289, Mfr. Part No. 30D206G050DC6M1, TQ 4.

Add 0683-1025, R: FXD 1000 OHM 5% 1/4W, Mfr. 01121, Mfr. Part No. CB 1025, TQ 2.

Delete HP Part No. 0683-1055.

Add 0683-1625, R: FXD COMP 1600 OHM 5% 1/4W, Mfr. 01121, Mfr. Part No. CB 1625, TQ 1.

Add 0683-1825, R: FXD COMP 1800 OHM 5% 1/4W, Mfr. 01121, Mfr. Part No. CB 1825, TQ 2.

Add 0683-2215, R: FXD COMP 220 OHM 5% 1/4W, Mfr. 01121, Mfr. Part No. CB 2215, TQ 6.

Add 0683-2725, R: FXD COMP 2700 OHM 5% 1/4W, Mfr. 01121, Mfr. Part No. CB 2725, TQ 3.

Change HP Part No. 0698-3150 TQ to 4.

Add 0757-0059, R: FXD MET FLM 1 MEGOHM 1% 1/2W, Mfr. 28480, Mfr. Part No. 0757-0059.

Delete HP Part Numbers: 0758-0003, 0758-0004, 0758-0015, 0758-0034, 0758-0043, and 0758-0063.

Page 5-13, Table 5-2:

Add HP Part No. 08745-2037, CABLE ASSY: TEST OUT TO A7, Mfr. 28480, Mfr. Part No. 08745-2037, TQ 1.

Add 08745-2039 CABLE ASSY: A6 to A8.

Delete HP Part Numbers: 08745-20060, 08745-20062, 08745-20063, and 08745-20064.

Page 6-9, Figure 6-11:

Delete A3C1, A3C2, A3C3, and A3C4.

Page 6-13, Figure 6-19:

Change A3R83 and A3R84 to 2370 ohm.

Change A5C1 thru A5C4 to 20 μ F.

CHANGE B: Page 5-7, Table 5-1:

Change F1 to: 2110-0008 FUSE:CARTRIDGE 1/2 AMP SLO-BLO (230V)

2110-0018 FUSE:CARTRIDGE 0.25 AMP SLO-BLO (115V).

Change S1 to: 3101-0100 SWITCH:PUSHBUTTON SPDT.

Change S2 to: 3101-0033 SLIDE SWITCH:DPDT.

Change W1 to: 8120-0078 CABLE ASSY:POWER CORD.

Page 5-8, Table 5-1:

Change Item 4 to: 08745-0012 SUB DECK.

Page 5-9, Table 5-1:

Change Item 1i to: 08745-0007 FRONT PANEL.

Page 5-13, Table 5-2:

Delete: 2110-0336 and 2110-0340

Add: 2110-0008 FUSE:1/2 AMP SLO-BLO (230V) 28480 2110-0008 TQ 1

2110-0018 FUSE:1/4 AMP SLO-BLO (115V) 28480 2110-0018 TQ 1.

Delete: 3101-1234

Add: 3101-0033 SWITCH:SLIDE DPDT 79727 6510 C TQ 1.

Delete: 3101-1248

Add: 3101-0100 SWITCH:PUSHBUTTON SPDT 87034 SW-624-109 TQ 1.

CHANGE B:
(Cont'd)

Delete: 8120-1348

Add: 8120-0078 CABLE ASSY:POWER CORD 28480 8120-0078 TQ 1.

Delete: 08745-00047

Add: 08745-0007 FRONT PANEL 28480 08745-0007 TQ 1.

Delete: 08745-00048

Add: 08745-0012 SUB DECK 28480 08745-0012 TQ 1.

MANUAL CHANGES

MANUAL CHANGES

NOTE

Manual change supplements are revised as often as necessary to keep manuals as current and accurate as possible. Hewlett-Packard recommends that you periodically request the latest edition of this supplement. Free copies are available from all HP offices. When requesting copies, quote the manual identification information from your supplement, or the model number and print date from the title page of the manual.

MANUAL IDENTIFICATION

Model Number: 8745A
 Date Printed: Feb. 1982 or
 Sept. 1979
 Part Number: 08745-90009

This supplement contains important information for correcting manual errors and for adapting the manual to instruments containing improvements made after the printing of the manual.

To use this supplement, make all ERRATA corrections and all appropriate serial number related changes indicated in the tables below.

● - NEW ITEM

Serial Prefix or Number	Make Manual Changes
906-00526 thru 00550	1
978-	2
999-	3
1142A-	4

Serial Prefix or Number	Make Manual Changes
1517A01186 thru 1517A Prefix	1-5
1705A	1-6
2431A	1-7

ERRATA

Service Note	Serial Number	Description
8745A-1	All serials	Replacing RF Source Relay Driver Transistors. Replacement of A3Q11, 12, 13, and 14.
8745A-2A-S*	0978A00050 through 1142A01165	Elimination of a Potential Shock Hazard. Hot and neutral reversed at power receptacle.

Page 1-1, Paragraph 1-5:
 Delete all references to Rack Mounting Kit.

Page 1-1, Paragraph 1-13:
 Add: "A Rack Mounting Kit is available to install the instrument in a 19-inch rack. Rack Mounting Kits may be obtained through your nearest Hewlett-Packard Office by ordering HP Part Number 5060-8740."

Page 1-2, Table 1-1:
 Change Directivity specification as follows:
 Below 1 GHz, ≥ 36 dB; 1-2 GHz, ≥ 32 dB in an environment of 10° to 30°C and 30 to 60% relative humidity for 24 hours.
 Just prior to POWER specification, add the following:
 Storage Temperature: 0 to 55°C.
 Change POWER specification to read: "115 or 230V $\pm 10\%$, 50 to 400 Hz, 50 VA."

9 JANUARY 1983

14 pages

Printed in U.S.A.



**HEWLETT
PACKARD**

ERRATA (Cont'd)

Page 2-1, Paragraph 2-14:

Change to read as follows:

"The Model 8745A requires a power source of 115 or 230 volts ac $\pm 10\%$, 50 to 400 Hz, single phase capable of supplying approximately 50 VA."

● Page 2-2, Paragraph 2-22:

Change the paragraph to read as follows:

The HP 8745A cabinet has plastic feet that provide clearance for air circulation and make the HP 8745A self-aligning when stacked on other Hewlett-Packard full rack-width modular instruments.

Page 2-2, Paragraph 2-24:

In the last sentence, change "55°C (140°F) to "30°C (86°F)."

Add a sentence: "The storage temperature range should not exceed 0° to 55°C."

Page 3-3, Figure 3-2:

Change Item 4 power requirements to : 115 to 230 Vac $\pm 10\%$, 50 to 400 Hz, approximately 50VA.

Page 3-7, Paragraph 3-14, add the following:

WARNING

When the bias supply is applied, the bias voltage is present on the center contacts of input ports A and B.

Page 3-7, Paragraph 3-15, add the following:

CAUTION

AVOID BIAS SUPPLY SWITCHING TRANSIENTS DURING TESTING. Turn down bias supply voltage (to 0.5V for collector supply) or currents before switching bias supply meter functions. Also, turn down the input circuit control and then bring it up to operating conditions rather than switching the bias supply off and on. If supplies are merely switched off and on, switching transients may damage sensitive transistors. If the power supplies are programmed, include a 0.5V program step or zero-current program step between each voltage or current step.

Page 3-8, Paragraph 3-16, add the following:

WARNING

When the bias supply is applied, the bias voltage is present on the center contacts of input ports A and B.

Page 3-21, Paragraph 3-37, add the following:

WARNING

Disconnect all power to the instrument before replacing inner conductor contacts.

Page 3-22, Paragraph 3-44, add the following:

WARNING

Disconnect all power to the instrument before replacing power switch lamp.

Page 4-2, Paragraph 4-22, add the following:

WARNING

Any servicing, adjustment, maintenance, or repair of this instrument must be performed only by qualified personnel.

ERRATA (Cont'd)

Page 4-7, Paragraph 4-43:

Add the following:

WARNING**Disconnect all power to the instrument before repairing RF connectors.**

Page 5-6, Table 5-1:

Change A6 to HP Part No. 08741-60004, ASSY: LINE STRETCHER.

Change A9 and A10 Assemblies to HP Part No. 5080-0305.

Change A11 Assembly to HP Part No. 5080-0306.

Page 5-7, Table 5-1:

Change DC1 to HP Part No. 5080-0304.

Change W4 and W7 to HP Part No. 5021-0160.

Change W5 and W8 to HP Part No. 5021-0161.

Change F1 HP Part No. 2110-0336 to FUSE: CARTRIDGE 0.8 AMP SLOW-BLOW (115V).

Change HP Part No. 2110-0340 to FUSE: CARTRIDGE 0.4 AMP SLOW BLOW (230V).

Change HP Part No. 08742-2022 under W2 and W3 to 08741-2010 CENTER CONDUCTOR MALE.

Add to W4 and W5 HP Part No. 5000-8676 WASHER: CABLE.

Change XF1 to HP Part No. 2110-0564 FUSEHOLDER-EXTR POST (RECOMMENDED REPLACEMENT).

Add under XF1 the following two items:

HP Part No. 2110-0569, CD3, FUSEHOLDER NUT-HEX.

HP Part No. 2110-0565, CD9, FUSEHOLDER CAP.

Page 5-8, Figure 5-1:

Delete Item 17.

Page 5-9, Table 5-1:

Change Item 6 to HP Part No. 08745-60067, PUSHBUTTON LENS REPLACEMENT KIT (includes Item 7, 1 ea. LABEL).

Change Item 9 to HP Part No. 08745-21077, CD5.

Page 5-10, Table 5-1:

Change Item 1 to HP Part No. 0370-1113, CD3.

Delete Item 2.

Page 6-5, Figure 6-6:

Change assembly descriptions to read as follows:

A6 LINE STRETCHER (08741-60004)

A9 RF SOURCE RELAY (5080-0305)

A10 RF SOURCE RELAY (5080-0305)

A11 RF SOURCE RELAY (5080-0306)

Page 6-13, Figure 6-18:

Change A5C1 through A5C4 to 2 μ F.**NOTE**

A new type power cord, power receptacle, ON-OFF switch, and front and rear panels to accommodate these parts were prematurely listed in the Table of Replaceable Parts. The following change documents the parts installed in your instrument.

CHANGE 1

Page 5-7, Table 5-1:

Change S1 to HP Part No. 3101-0100, SWITCH: PUSHBUTTON SPDT.

Page 5-9, Table 5-1:

Change Item 11 to HP Part No. 08745-0007, FRONT PANEL.

CHANGE 2

Page 5-4, Table 5-1:

Change A3Q12 and A3Q14 to HP Part No. 1853-0012: TRANSISTOR: SILICON PNP (2N2904) (Recommended Replacement).

Page 6-13, Figure 6-19:

Change A3Q12 and A3Q14 to HP Part No. 1853-0012.

CHANGE 3

Page 5-2, Table 5-1:

Change A3 to HP Part No. 08745-60066.

Page 5-4, Table 5-1:

Change A3Q11 and A3Q13 to HP Part No. 1854-0072. Change A3Q12 and A3Q14 to HP Part No. 1853-0052.

Page 6-13, Figure 6-18:

Replace with the attached Figure 6-18.

Page 6-13, Figure 6-19:

Change A3Q11 and A3Q13 to HP Part No. 1854-0072. Change A3Q12 and A3Q14 to HP Part No. 1853-0052.

CHANGE 4

Page 5-2, Table 5-1:

Add the following note to Replaceable Parts as an aid in explaining the 8745A color scheme.

NOTE

This change implements a different color scheme for the standard instrument. Colors prior to this change are now available as options. Refer to listing below.

8745A STANDARD - Indicates color scheme for the 8745A beginning with this change. (Includes MINT GRAY front panel and OLIVE GRAY cabinet).

8745A OPTION A85 - Indicates LIGHT GRAY front panel.

8745A OPTION X95 - Indicates color scheme for the 8745A prior to this change. (Includes LIGHT GRAY front panel and BLUE GRAY cabinet).

Page 5-9, Figure 5-2:

Change HP Part No. 08745-2020 to:

HP Part No. 08745-20069 TRIM: UPPER FRAME (MINT GRAY) (STANDARD).

HP Part No. 08745-2020 TRIM: UPPER FRAME (LIGHT GRAY) (OPTION A85, X95).

Change HP Part No. 08745-2019 to:

HP Part No. 08745-20068 TRIM: LOWER FRAME (MINT GRAY) (STANDARD).

HP Part No. 08745-2019 TRIM: LOWER FRAME (LIGHT GRAY) (OPTION A85, X95).

Change HP Part No. 0370-0766 to:

HP Part No. 0370-0976 END CAP: RIGHT (JADE GRAY) (STANDARD).

HP Part No. 0370-0766 END CAP: RIGHT (GRAY) (OPTION A85, X95).

Change HP Part No. 0370-0767 to:

HP Part No. 0370-0974 PUSHBUTTON (JADE GRAY) (STANDARD).

HP Part No. 0370-0767 PUSHBUTTON (GRAY) (OPTION A85, X95).

Change HP Part No. 0370-0765 to:

HP Part No. 0370-0975 END CAP: LEFT (JADE GRAY) (STANDARD).

HP Part No. 0370-0765 END CAP: LEFT (GRAY) (OPTION A85, X95).

Change HP Part No. 5040-0204 to:

HP Part No. 5040-0351 BEZEL: COUNTER (MINT GRAY) (STANDARD).

HP Part No. 5040-0204 BEZEL: COUNTER (GRAY) (OPTION A85, X95).

Change HP Part No. 08745-00047 to:

HP Part No. 08745-00058 FRONT PANEL (MINT GRAY) (STANDARD).

HP Part No. 08745-00047 FRONT PANEL (LIGHT GRAY) (OPTION A85, X95).

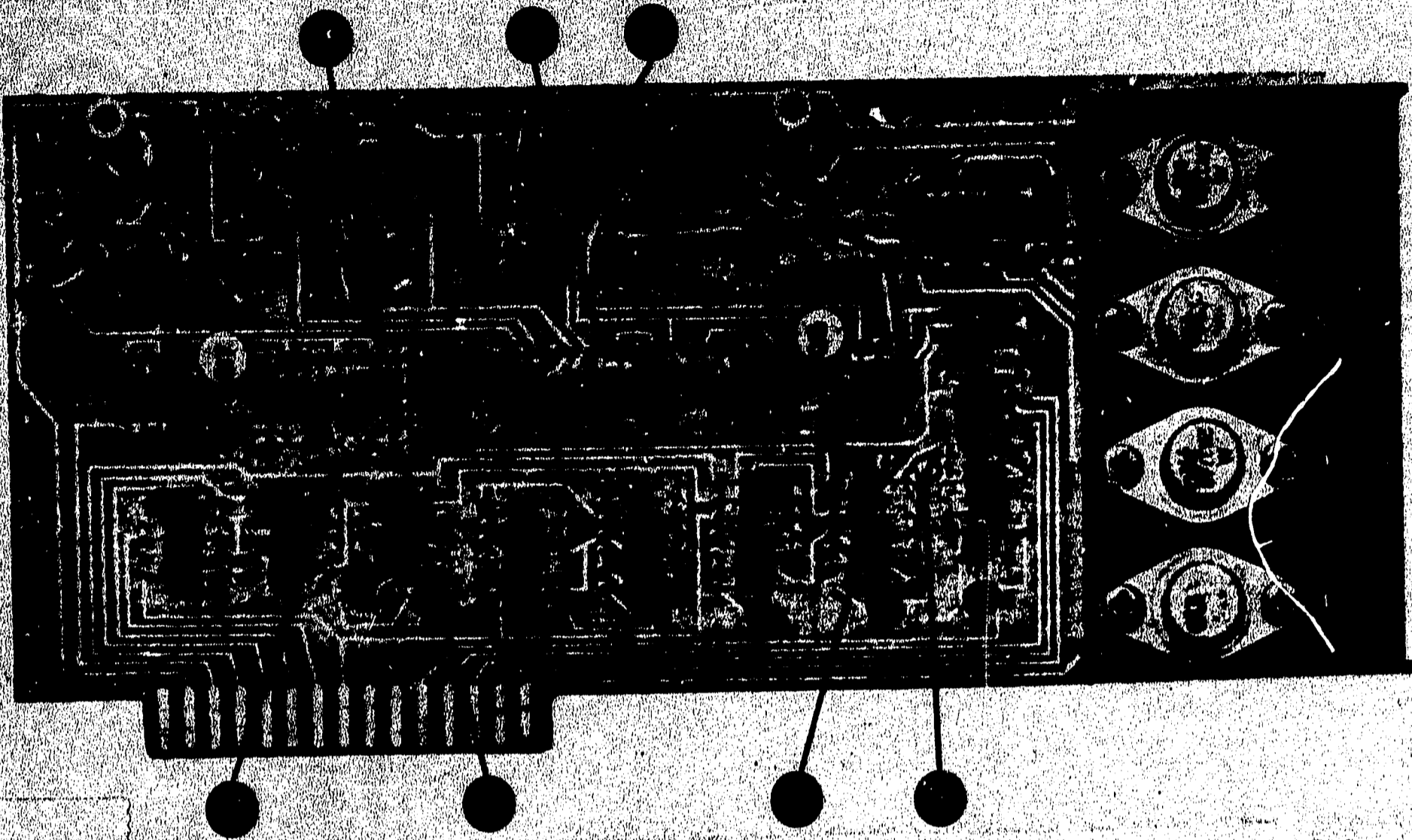

Figure 6-18. A3 Relay Driver Assembly Component Identification for OR-Gate, AND-Gate and Relay Drivers Serial Numbers Prefixed 906- and Above

CHANGE 4 (Cont'd)

Page 5-8, Table 5-1:

Change HP Part No. 08745-0008 to:

HP Part No. 08745-00051 TOP COVER ASSY (OLIVE GRAY) (STANDARD).
HP Part No. 08745-0008 TOP COVER ASSY (BLUE GRAY) (OPTION X95).

Change HP Part No. 08745-00048 to:

HP Part No. 08745-00059 SUB DECK (OLIVE GRAY) (STANDARD).
HP Part No. 08745-00048 SUB DECK (BLUE GRAY) (OPTION X95).

Change HP Part No. 08745-0018 to:

HP Part No. 08745-00055 FILLER PIECE: SIDE FRAME (OLIVE GRAY) (STANDARD).
HP Part No. 08745-0018 FILLER PIECE: SIDE FRAME (BLUE GRAY) (OPTION X95).

Change HP Part No. 08745-0016 to:

HP Part No. 08745-00054 FILLER PLATE (OLIVE GRAY) (STANDARD).
HP Part No. 08745-0016 FILLER PLATE (BLUE GRAY) (OPTION X95).

Change HP Part No. 08745-0013 to:

HP Part No. 08745-00053 COVER: TOP REAR CORNER (OLIVE GRAY) (STANDARD).
HP Part No. 08745-0013 COVER: TOP REAR CORNER (BLUE GRAY) (OPTION X95).

Change HP Part No. 08745-00046 to:

HP Part No. 08745-00057 REAR PANEL (MINT GRAY) (STANDARD).
HP Part No. 08745-00046 REAR PANEL (LIGHT GRAY) (OPTION X95).

Change HP Part No. 5060-0766 to:

HP Part No. 5060-8737 RETAINER: HANDLE ASSY (OLIVE) (STANDARD).
HP Part No. 5060-0766 RETAINER: HANDLE ASSY (BLUE GRAY) (OPTION X95).

Change HP Part No. 5000-0098 to:

HP Part No. 5000-8527 SIDE COVER: REAR (OLIVE) (STANDARD).
HP Part No. 5000-0098 SIDE COVER: REAR (BLUE GRAY) (OPTION X95).

CHANGE 4 (Cont'd)

Page 5-8, Table 5-1: (Cont'd)

Change HP Part No. 5000-0099 to:

HP Part No. 5000-8529 SIDE COVER: FRONT (OLIVE) (STANDARD).

HP Part No. 5000-0099 SIDE COVER: FRONT (BLUE GRAY) (OPTION X95).

Change HP Part No. 08745-0009 to:

HP Part No. 08745-00052 BOTTOM COVER ASSY (OLIVE GRAY) (STANDARD).

HP Part No. 08745-0009 BOTTOM COVER ASSY (BLUE GRAY) (OPTION X95).

Change HP Part No. 5060-0775 to:

HP Part No. 5060-8740 KIT: RACK MOUNT (MINT GRAY) (STANDARD).

HP Part No. 5060-0775 KIT: RACK MOUNT (LIGHT GRAY) (OPTION A85, X95).

Page 5-13, Table 5-2:

Add the following:

HP Part No. 08745-00056 REAR DECK EXTENSION (OLIVE GRAY) (STANDARD).

HP Part No. 08745-00045 REAR DECK EXTENSION (BLUE GRAY) (OPTION X95).

CHANGE 5

Page 5-7, Table 5-1:

Change C2A, C2B to HP Part No. 0160-3043 C:FXD CER 2 X .005 MFD.

Change XF1 to HP Part No. 2110-0464.

Add HP Part No. 2110-0465 FUSEHOLDER CAP.

Add HP Part No. 2110-0467 NUT-HEX 1/2-28.

Add HP Part No. 7120-4162 LABEL INFO.

Page 5-12, Table 5-2:

Change HP Part No. 0150-0119 to: HP Part No. 0160-3043 C:FXD CER 2X .005 MFD.

Delete HP Part No. 1400-0084 FUSEHOLDER: EXTRACTOR POST TYPE.

Page 5-13, Table 5-2:

Add HP Part No. 2110-0464 FUSEHOLDER.

Add HP Part No. 2110-0465 FUSEHOLDER CAP.

Add HP Part No. 2110-0467 NUT-HEX 1/2-28.

Page 6-15, Figure 6-22:

Change C2A and C2B to .005 μ F.**CHANGE 6**

Page 5-7, Table 5-1:

Change C2A, C2B to C2 HP Part No. 0150-0052 C:FXD CER .05UF \pm 20% 400VDC.

Change S1 to HP Part No. 3101-1951 SWITCH: PUSHBUTTON DPST.

Page 6-15, Figure 6-22:

Change the primary power circuit as shown in the attached partial schematic (Figure 6-22A).

► CHANGE 7

Page 3-7, Figure 3-7:

Change Figure 3-7 in the manual as shown on the attached Figure: Figure 3-7 (CHANGE 7).

Page 5-6, Table 5-1:

Change the A5 assembly HP Part Number to 08745-60078 CD 0.

Delete A5C3 and A5C4.

Change A5C1 and A5C2 to HP Part Number 0160-0162 CD 5, CAPACITOR-FXD .022 μ f \pm 10% 200VDC POLYE.

Change A5R1 and A5R2 to HP Part Number 0757-0394 CD 0, RESISTOR 51.1 1% .125W F TC=0 \pm 100.

Add A5E1-14 HP Part Number 1251-0600 CD 0, CONNECTOR-SGL CONT PIN 1.14-MM-BSC-SZ SQ.

Add A5W1 HP Part Number 8150-0450 CD 1, WIRE 24 300V.

Add A5W2 HP Part Number 8150-0453 CD 4, WIRE 24 300V.

Add A5Z1-4 HP Part Number 9170-0016 CD 8, CORE-SHIELDING BEAD.

Page 6-12, Figure 6-17:

Replace the Component Identification, Figure 6-17, with the Figure 6-17 supplied in this change sheet. Figure 6-17 (CHANGE 7).

Page 6-13, Figure 6-19:

Change Figure 6-19 in the manual as shown on the attached Figure: Part of Figure 6-19 (CHANGE 7).

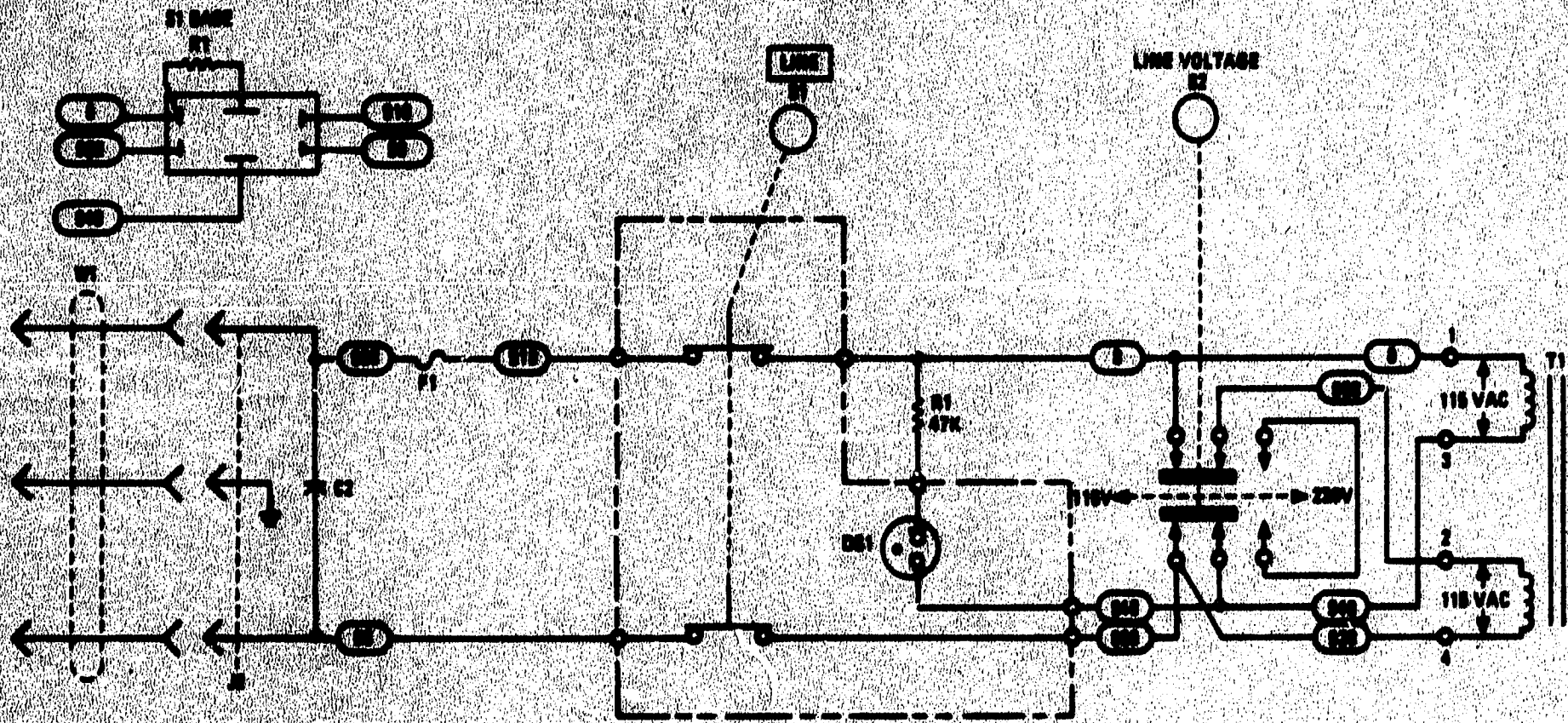
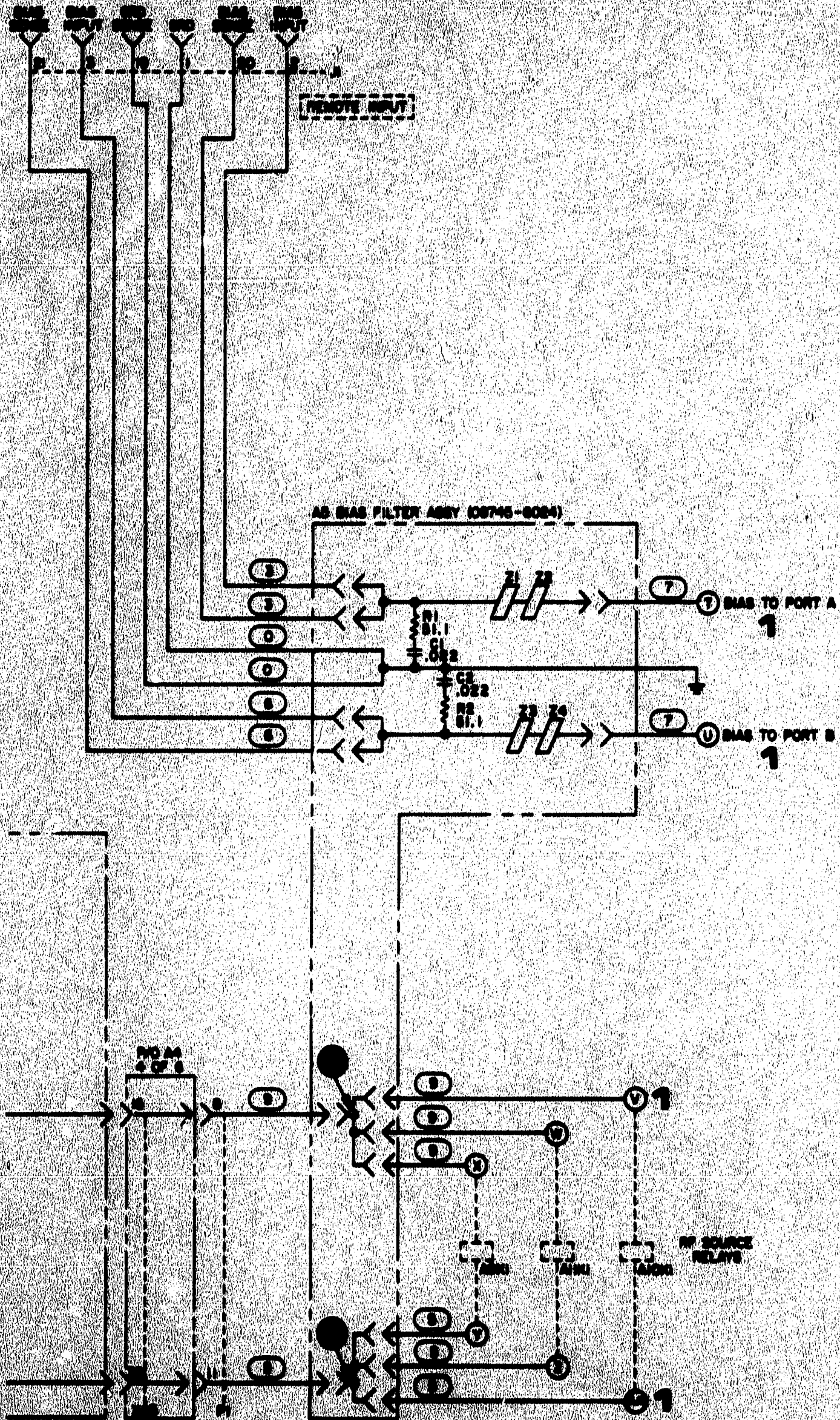

Figure 6-22A. Relay Control Section Partial Schematic (CHANGE 6)



Part of Figure 6-19. Relay Control Section Schematic Diagram. Relay Drivers, RF Relays and Bias Filter (CHANGE 7)

4

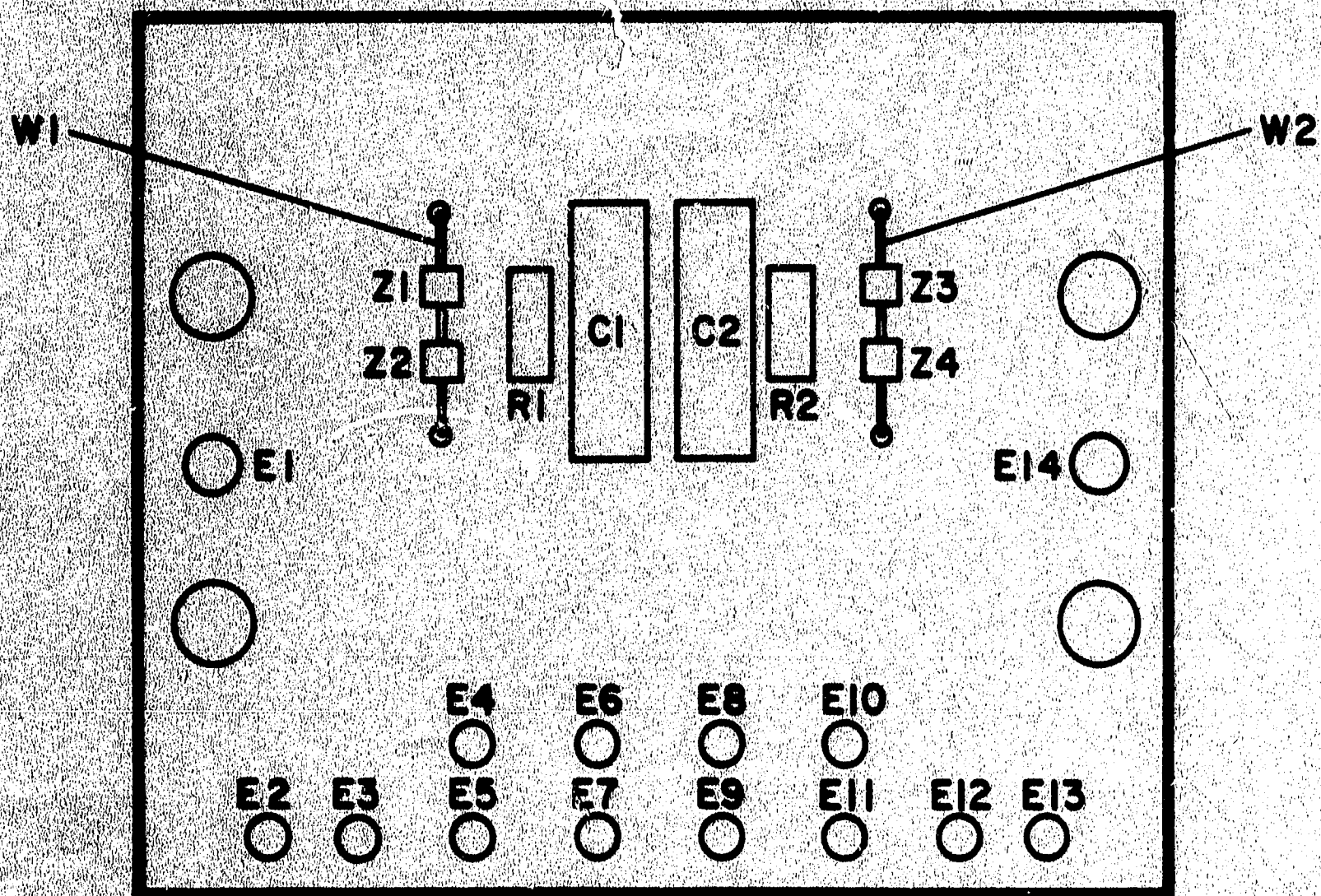

Figure 6-17. A5 Bias Filter Assembly Component Identification (CHANGE 7)