

About this Manual

We've added this manual to the Agilent website in an effort to help you support your product. This manual is the best copy we could find; it may be incomplete or contain dated information. If we find a more recent copy in the future, we will add it to the Agilent website.

Support for Your Product

Agilent no longer sells this product. Our service centers may be able to perform calibration and repair if necessary, but no other support from Agilent is available. You will find any other available product information on the Agilent Test & Measurement website, www.tm.agilent.com.

HP References in this Manual

This manual may contain references to HP or Hewlett-Packard. Please note that Hewlett-Packard's former test and measurement, semiconductor products and chemical analysis businesses are now part of Agilent Technologies. We have made no changes to this manual copy. In other documentation, to reduce potential confusion, the only change to product numbers and names has been in the company name prefix: where a product number/name was HP XXXX the current name/number is now Agilent XXXX. For example, model number HP8648A is now model number Agilent 8648A.

www.valuetronics.com

SYNCHRONIZER

8709A

THIS MANUAL CONTAINS A
SUPPLEMENT FOR A SPECIAL
MODIFICATION TO THE
INSTRUMENT.
SEE INSIDE COVER.



HEWLETT  PACKARD

www.valuetronics.com

SAFETY

This instrument has been designed and tested according to IEC Publication 348, "Safety Requirements for Electronic Measuring apparatus," and has been supplied in safe condition. This is a Safety Class I instrument. To ensure safe operation and to keep the instrument safe, the information, cautions, and warnings in this manual must be heeded. Refer to Section I for general safety considerations applicable to this instrument.

CERTIFICATION

The Hewlett-Packard Company certifies that this instrument was thoroughly tested and inspected and found to meet its published specifications when it was shipped from the factory. The Hewlett-Packard Company further certifies that its calibration measurements are traceable to the U.S. National Bureau of Standards to the extent allowed by the Bureau's calibration facilities, or to the calibration facilities of other International Standards Organization members.

WARRANTY AND ASSISTANCE

This Hewlett-Packard product is warranted against defects in materials and workmanship. This warranty applies for one year from the date of delivery. Hewlett-Packard will repair or replace products which prove to be defective during the warranty period provided they are returned to Hewlett-Packard. No other warranty is expressed or implied. We are not liable for consequential damages.

Service contracts or customer assistance agreements are available for Hewlett-Packard products that require maintenance and repair on-site.

For any assistance, contact your nearest Hewlett-Packard Sales and Service Office.

MANUAL CHANGES

MANUAL IDENTIFICATION

Model Number: 8709A
Date Printed: June 1969
Part Number: 08709-90004

This supplement contains important information for correcting manual errors and for adapting the manual to instruments containing improvements made after the printing of the manual.

To use this supplement:

Make all ERRATA corrections

Make all appropriate serial number related changes indicated in the tables below.

Serial Prefix or Number	Make Manual Changes
837-00147 thru 837-00151	1
948-00152 thru 966-00161	1,2
0966A00192 thru 0966A00215	1,2,3

► NEW ITEM

ERRATA

► Inside front cover:

Insert new information regarding SAFETY, CERTIFICATION, and WARRANTY AND ASSISTANCE immediately inside front cover of manual (new information sheet supplied in this Manual Changes Supplement).

► Page 1-1, General Information:

Add the following information preceding Paragraph 1-1:

1-1A. SAFETY CONSIDERATIONS

General

This is a Safety Class I instrument and has been manufactured and tested according to international safety standards.

Operation

BEFORE APPLYING POWER make sure the ac input of the instrument is set for the available ac line voltage, that the correct fuse is installed, and that all normal safety precautions have been taken. (See Warnings below).

Serial Prefix or Number	Make Manual Changes
1141A00216	1,2,3,4
1221A00245 thru 1221A00314	1-5
1418A00315 thru 1418A00366	1-6
1448A00367 thru 1448A Prefix	1-7
► 1646A	1-8

NOTE

Manual change supplements are revised as often as necessary to keep manuals as current and accurate as possible. Hewlett-Packard recommends that you periodically request the latest edition of this supplement. Free copies are available from all HP offices. When requesting copies quote the manual identification information from your supplement, or the model number and print date from the title page of the manual.

www.valuetronics.com

30 May 1977

13 Pages

HEWLETT  PACKARD

Printed in U.S.A.

1-1A. SAFETY CONSIDERATIONS (Cont'd)

Safety Symbols

 Instruction manual symbol: the apparatus will be marked with this symbol when it is necessary for the user to refer to the instruction manual in order to protect the apparatus against damage.

 Indicates dangerous voltages.

 Earth terminal (sometimes used in manual to indicate circuit connected to grounded chassis).

WARNING

The WARNING sign denotes a hazard. It calls attention to a procedure, practice, or the like which, if not correctly performed or adhered to, could result in injury or loss of life. Do not proceed beyond a WARNING sign until the indicated conditions are fully understood and met.

CAUTION

The CAUTION sign denotes a hazard. It calls attention to an operating procedure, practice, or the like which, if not correctly performed or adhered to, could result in damage to or destruction of part or all of the equipment. Do not proceed beyond a CAUTION sign until the indicated conditions are fully understood and met.

Operation

CAUTION

BEFORE APPLYING POWER make sure the ac input of the instrument is set for the available ac line voltage, that the correct fuse is installed, and that all normal safety precautions have been taken.

Service

The information, cautions, and warnings in this manual must be followed to ensure safe operation and to keep the instrument safe. SERVICE AND ADJUSTMENTS SHOULD BE PERFORMED ONLY BY QUALIFIED SERVICE PERSONNEL.

www.valuetronics.com
Adjustment or repair of the opened instrument with the

ac power connected should be avoided as much as possible and, when unavoidable, should be performed only by a skilled person who knows the hazard involved.

Capacitors inside the instrument may still be charged even though the instrument has been disconnected from its source of supply.

Make sure only fuses of the required current rating and type (normal blow, time delay, etc.) are used for replacement. Fuse requirements are indicated on the instrument rear panel. Do not use repaired fuses or short-circuit fuse holders.

Whenever it is likely that the protection has been impaired, make the instrument inoperative and secure it against any unintended operation.

WARNING

If this instrument is to be energized through an auto-transformer (for voltage reduction), make sure the common terminal is connected to the earth pole of the power source.

BEFORE SWITCHING ON THE INSTRUMENT, the protective earth terminal of the instrument must be connected to the protective conductor of the (main) power cord. The main plug shall only be inserted in a socket outlet provided with protective earth contact. The protection action must not be negated by using an extension cord (power cable) without a protective grounding conductor. Grounding one conductor of a two-conductor outlet is not sufficient protection.

Any interruption of the protective (grounding) conductor, inside or outside the instrument, or disconnection of the protective earth terminal is likely to make this instrument dangerous. Intentional interruption of the earth ground is prohibited. Whenever it is likely that the protection has been impaired, the instrument must be secured against any unintended operation.

Servicing this instrument often requires that you work with the protective covers removed and with ac power connected. Be very careful; the energy at many points in the instrument may, if contacted, cause personal injury.

ERRATA (Cont'd)

- Page 2-1, paragraph 2-5:
Add following WARNING before NOTE:

WARNING

BEFORE THIS INSTRUMENT IS SWITCHED ON, its protective earth terminals must be connected to the protective conductor of the main power cable (cord). The main power cable plug shall be inserted only in a socket outlet provided with a protective earth contact. DO NOT negate the earth-grounding protection by using an extension cable, power cable, or autotransformer without a protective ground conductor. Failure to ground the instrument properly can result in personal injury.

Page 4-1, paragraph 4-2, first sentence:

Change to read "The basic components of a typical frequency stabilizing system are shown in Figure 3-3."

Parts List: Delete reference to the following BLANK printed circuit boards:

A1	08709-2003	A6	08410-2009
A2	08709-2000	A7	08410-2041
A5	08410-2006	A8	08410-2007

Change A1R8 and A1R9 to R:fxd, WW, 2.2 ohm, 3%, 3W, HP Part No. 0812-0039.

Change A2R18 and A1R19 to R:fxd, WW, 5 ohm, 5%, 3W, HP Part No. 0812-0086.

Change A1R25 to R:fxd, met flm, 12.1K ohm, 1%, 1/8W, HP Part No. 0757-0444.

Change A1R35 and A1R36 to R:fxd, met flm, 31.6K ohm, 1%, 1/8W, HP Part No. 0698-3160.

Add A1R38, R:fxd, met flm, 10K ohm, 1%, 1/8W, HP Part No. 0757-0442.

Add A1R40, R:fxd, met ox, 330 ohm, 5%, 2W, HP Part No. 0698-3631.

Change A2C4 to C:fxd, cer, 2.0 pF, ±0.25 pF, 500 VDCW, HP Part No. 0160-2240.

Change A2C6 to C:fxd, cer, 1.8 pF, ±0.25 pF, 500 VDCW, HP Part No. 0160-2239.

Delete A2J3.

Change A4R8 to R:fxd, met flm, 1620 ohm, 1%, 1/8W, HP Part No. 0757-0428.

Change A5C2 to C:fxd, cer, 8.2 pF ±0.25 pF, 500 VDCW, HP Part No. 0160-2255.

Change A5C3 to C:fxd, mica, 56 pF, 5%, 300 VDCW, HP Part No. 0140-0191.

Change A5C4, A5C5, A5C7, A5C8, A5C9, A5C14, and A5C15 to C:fxd, cer, 0.01 uF +80-20%, 100 VDCW, HP Part No. 0160-2930.

Change A5C16 to C:fxd, mylar, 3300 pF, 10%, 200 VDCW, HP Part No. 0160-0155.

Change A5L2 to Coil:Molded Choke, 8.2 uH, 10%, HP Part No. 9140-0105.

Change A5Q4, A5Q5, and A5Q6 to Transistor:NPN Silicon, HP Part No. 1854-0073.

Change A5R7 to R:fxd, met flm, 825 ohm, 1%, 1/8W, HP Part No. 0757-0421.

Change A6C1, A6C2, A6C3, A6C4, A6C10, A6C13, and A6C13, and A6C14 to C:fxd, cer, 0.01 uF, +80-20%, 100 VDCW, HP Part No. 0160-2930.

Change A6CR1 and A6CR2 to Diode:Germanium, HP Part No. 1910-0022.

Change A6Q1 and A6Q2 to Transistor:NPN Silicon, HP Part No. 1854-0073.

Change A6Q3 to Transistor:PNP Silicon, HP Part No. 1853-0034.

Add A6R16, R:fxd, met flm, 2370 ohm, 1%, 1/8W, HP Part No. 0698-3150.

Add A6R17, R:fxd, met flm, 196 ohm, 1%, 1/8W, HP Part No. 0698-3440.

Add A6R18, R:fxd, met flm, 100 ohm, 1%, 1/8W, HP Part No. 0757-0401.

Add A6R19, R:fxd, met flm, 3160 ohm, 1%, 1/8W, HP Part No. 0757-0279.

Change A7Q3 to Transistor:Field-Effect, P Channel, 2N4360, HP Part No. 1855-0052.

Change A8 Assembly from HP Part No. 08410-6007 to HP Part No. 08709-6010.

Change A8R2* to nominal value of 82.5 ohm, 1%, HP Part No. 0757-0399. Retain the asterisk (*) to indicate "FACTORY SELECTED PART, TYPICAL VALUE GIVEN."

Add J4, Connector:AC Receptacle, HP Part No. 1251-0148.

Interchange S2 and S3.

ERRATA:
(Cont'd)

Change new S2 (formerly S3) from HP Part No. 3101-0070 to HP Part No. 3101-0033.
Change XDS1 and CDS2, Lens:Lampholder, from HP Part No. 1450-0157 to HP Part No. 1450-0167.

Add W1, Power Cable:Detachable, HP Part No. 8120-0078.

Page 4-14, Figure 4-9a:

Change reference to search signal frequency from 500 kHz to 500 Hz.

►Page 5-1, paragraph 5-2:

Add following WARNING:

WARNING

When covers are removed, terminals are exposed that have voltages capable of causing personal injury or death. Maintenance procedures in this section should be performed only by a skilled person who is aware of the hazard involved.

Page 6-13, Table 6-1:

Change XF1 to HP Part No. 2110-0464 FUSEHOLDER.

Add HP Part No. 2110-0465 FUSEHOLDER CAP..

Add HP Part No. 2110-0467 NUT-HEX 1/2-28.

Page 6-18, Table 6-1:

Change COVER: LOWER PC HOUSING to HP Part No. 5000-3337.

Add HP Part No. 7120-4163 LABEL, INFO QTY 1.

Page 7-5, Figure 7-4b:

Reverse positions of A2C9 and A2R4.

Page 7-7, Figure 7-5c:

The positive end of C5 should be shown connected directly to CR5 and CR6, and not to the emitter of Q10.

The positive end of C10 should be shown connected directly to CR13 and CR14, and not to the emitter of Q4.

ERRATA:
(Cont'd)

Pages 7-9/7-10, Figure 7-6c:

Change designation of existing R42 to R43.

Change designation of existing R43 to R44, and change value to 681 ohms.

Change Note 2 to read "ADJUST FOR MINIMUM 500 Hz SEARCH SIGNAL ON SERVO VOLTAGE WITH SYNCHRONIZER UNLOCKED."

Pages 7-13/7-14, Figure 7-8b and Parts List:

Change A2C1 to C:fxd, cer, 10 pF, 20%, 200 VDCW, HP Part No. 0160-2436.

Pages 7-15/7-16, Figure 7-9b and Parts List:

Change A5C6 to C:fxd, mica, 20 pF, 5%, 500 VDCW, HP Part No. 0160-0370.

Delete A5C17 from Reference Designation Box and from Parts List.

Delete A5L5 from Reference Designation Box and from Parts List.

Change A5R3 and A5R6 to R:fxd, met flm, 19.6K ohm, 1%, 1/8W, HP Part No. 0698-3157.

Change A5R13 to R:fxd, met flm, 147 ohm, 1%, 1/8W, HP Part No. 0698-3438.

Pages 7-17/7-18, Figure 7-10b and Parts List:

Change A6R2 to R:fxd, met flm, 16.2K ohm, 1%, 1/8W, HP Part No. 0757-0447.

Page 7-19, Figure 7-11b:

Correct the input and output circuits to A7 according to the following schematics.

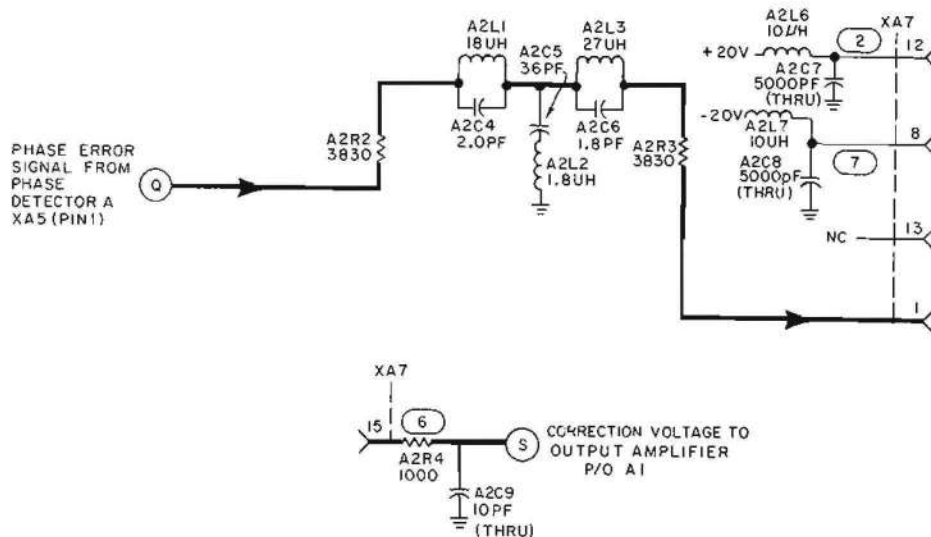

Page 7-21, Figure 7-2

Page 7-21, Figure 7-12b:

Correct the input circuit to A8 according to the following schematic.

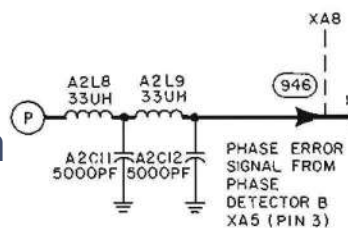

SAFETY

This instrument has been designed and tested according to International Safety Requirements. To ensure safe operation and to keep the instrument safe, the information, cautions, and warnings in this manual must be heeded. Refer to Section I for general safety considerations applicable to this instrument.

CERTIFICATION

Hewlett-Packard Company certifies that this instrument met its published specifications at the time of shipment from the factory. Hewlett-Packard Company further certifies that its calibration measurements are traceable to the United States National Bureau of Standards, to the extent allowed by the Bureau's calibration facility, and to the calibration facilities of other International Standards Organization members.

WARRANTY AND ASSISTANCE

This Hewlett-Packard product is warranted against defects in materials and workmanship for a period of one year from the date of shipment. Hewlett-Packard will, at its option, repair or replace products which prove to be defective during the warranty period provided they are returned to Hewlett-Packard. Repairs necessitated by misuse of the product are not covered by this warranty. NO OTHER WARRANTIES ARE EXPRESSED OR IMPLIED, INCLUDING BUT NOT LIMITED TO THE IMPLIED WARRANTIES OF MERCHANTABILITY AND FITNESS FOR A PARTICULAR PURPOSE. HEWLETT-PACKARD IS NOT LIABLE FOR CONSEQUENTIAL DAMAGES.

Service contracts or customer assistance agreements are available for Hewlett-Packard products that require maintenance and repair on-site.

For any assistance contact your nearest Hewlett-Packard Sales and Service Office. Addresses are provided at the back of this manual.

www.valuetronics.com

CHANGE 1: Page 7-7, Figure 7-5c and Parts List:
Add A1R45, R:Var, 2K ohm, HP Part No. 2100-2497 to Parts List. Place on schematic between R2 and R3, with the wiper arm going to the base of Q6. This potentiometer provides fine adjustment of the +20V power supply.

Add A1R46, R:Var, 2K ohm, HP Part No. 2100-2497 to Parts List. Place on schematic between R12 and R13, with the wiper arm going to the base of Q5. This potentiometer provides fine adjustment of the -20V power supply.

CHANGE 2: Parts List:

Change F1 (115V) from 0.25 amp slo-blo, HP Part No. 2110-0018 to 0.4 amp slo-blo, HP Part No. 2110-0340.

Change F1 (230V) from 0.125 amp slo-blo, HP Part No. 2110-0064 to 0.2 amp slo-blo, HP Part No. 2110-0235.

Change J4 from HP Part No. 1251-0148 to HP Part No. 1251-2357.

Change S2 from HP Part No. 3101-0033 to HP Part No. 3101-1234.

Change XDS1, Lens: Lampholder Red Plastic, HP Part No. 1450-0152 to Lens: Lampholder White Plastic, HP Part No. 1450-0157.

Change W1, Power Cable: Detachable, from HP Part No. 8120-0078 to HP Part No. 8120-1348.

CHANGE 3: Page 6-6, Table 6-1:

Change A3C3 to HP Part No. 0140-0190, C: FXD MICA 39 pF 5% 300V.

Change A3L1 to HP Part No. 9100-1616, COIL: MOLDED CHOKE 1.5 UH 10%.

Change A3L2 to HP Part No. 9140-0111, COIL: MOLDED CHOKE 3.3 UH 10%.

Change A4L1 to HP Part No. 9140-0098, COIL: MOLDED CHOKE 2.2 UH 10%.

Page 6-7, Table 6-1:

Change A4L2 to HP Part No. 9140-0111, COIL: MOLDED CHOKE 3.3 UH 10%.

Page 7-11/7-12, Figure 7-7b:

Change C3 to 39 pF.

Change L1 to 1.5 UH.

Change L2 to 3.3 UH.

Page 7-13/7-14, Figure 7-8b:

Change L1 to 2.2 UH.

Change L2 to 3.3 UH.

CHANGE 4: Add the following note to Replaceable Parts for explanation of the 8709A color scheme.

NOTE

This change implements a different color scheme for the standard instrument. Color scheme prior to this change is now available as an option.

8709A STANDARD - Indicates 8709A color scheme beginning with this change. (Includes MINT GRAY front panel, OLIVE BLACK meter bezel and OLIVE GRAY cabinet).

8709A OPTION A85 - Indicates LIGHT GRAY panel.

8709A OPTION Y98 - Indicates BLUE GRAY cabinet.

8709A OPTION X95 - Indicates complete 8709A color scheme prior to this change.

(Includes LIGHT GRAY front panel, BLACK meter bezel, and BLUE GRAY cabinet).

**CHANGE 4
(Cont'd)**

Page 6-11, Table 6-1:

Add A8C2, HP Part No. 0160-0127, CF 1.0 μ F 20% 25V
 Add A8CR1, HP Part No. 1901-0025, Diode Sil. 150V

Page 6-12, Table 6-1:

Add A8R41, HP Part No. 0757-0442, RF 10K 1% 1/8W
 Add to Reference Designation M1 HP Part Number
 4040-0906 BEZEL: METER (OLIVE BLACK) (STANDARD)
 4040-0297 BEZEL: METER (BLACK) (OPTIONS)

Page 6-14, Table 6-1:

Add to Reference Designation 6 HP Part Number
 5000-8565 SIDE COVER (OLIVE GRAY) (STANDARD)
 5000-0703 SIDE COVER (BLUE GRAY) (OPTIONS)

Add to Reference Designation 7 HP Part Number
 5060-8577 COVER: HALF-RECESS TOP (OLIVE GRAY) (STANDARD)
 5060-0720 COVER: HALF-RECESS TOP (BLUE GRAY) (OPTIONS)

Add to Reference Designation 8 HP Part Number
 5000-8583 COVER: HALF-MODULE BOTTOM (OLIVE GRAY) (STANDARD)
 5000-0717 COVER: HALF-MODULES BOTTOM (BLUE GRAY)(OPTIONS)

Change Reference Designation 9 to HP Part Number
 08709-00005 REAR PANEL

Add to Reference Designation 10 HP Part Number
 08709-00006 FRONT PANEL (MINT GRAY) (STANDARD)
 08709-0002 FRONT PANEL (LIGHT GRAY) (OPTIONS)

Page 6-18, Table 6-2:

Add HP Part Number 4040-0906 BEZEL: METER (OLIVE BLACK)(STANDARD)
 Add HP Part Number 4040-0297 BEZEL: METER (BLACK) (OPTIONS)

Page 6-19, Table 6-2:

Add HP Part Number 5000-8565 SIDE COVER (OLIVE GRAY) (STANDARD)
 Add HP Part Number 5000-0703 SIDE COVER (BLUE GRAY) (OPTIONS)

Add HP Part Number 5000-8583 COVER: HALF-MODULE BOTTOM (OLIVE GRAY) (STANDARD)
 Add HP Part Number 5000-0717 COVER: HALF-MODULE BOTTOM (BLUE GRAY) (OPTIONS)

Add HP Part Number 5060-8577 COVER: HALF-RECESS TOP (OLIVE GRAY) STANDARD)
 Add HP Part Number 5060-0720 COVER: HALF-RECESS TOP (BLUE GRAY) (OPTIONS)

Change HP Part Number 08709-0001 REAR PANEL to read HP Part Number 08709-00005 REAR
 PANEL

Add HP Part Number 08709-00006 FRONT PANEL (MINT GRAY) (STANDARD)
 Add HP Part Number 08709-0002 FRONT PANEL (LIGHT GRAY) (OPTIONS)

Page 7-21/7-22, Figure 7-12a:

Change A8 Search Generator Board Assembly Component Identification and Location per
 the revised photo attached.

CHANGE 4
(Cont'd)

Page 7-21/7-22, Figure 7-12-b:

Add the following partial schematic between XA8 PIN 14 and the junction of A8Q9 Collector, A8R30 and A8R32.

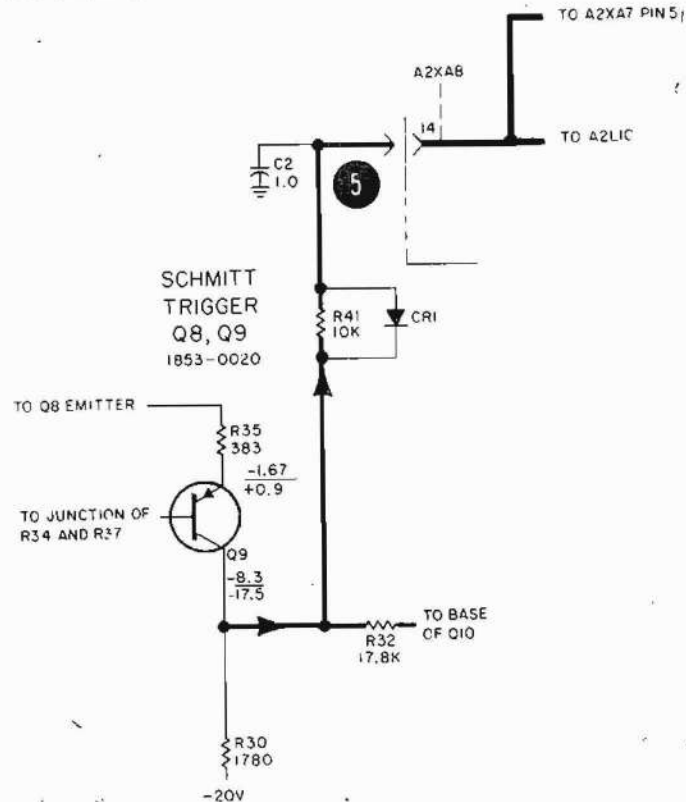

CHANGE 5: Change all reference to search oscillator frequency from its present 500 - 600 Hz, to approximately 100 Hz. (In some places in manual search oscillator frequency has been referred to as being 500 to 600 kHz.)

Page 4-7, Figure 4-5b.

Change Figure 4-5b to the attached figure 7-8b.

Page 6-2, Table 6-1.

Change A1C13 and A1C14 to HP Part No. 0160-0174 C:FXD 0.47 μ F 25 V.

Page 6-6, Table 6-1.

Change A3C3 to HP Part No. 0140-0193 C:FXD 82 pF 300V.

Change A3L1 to HP Part No. 9140-0111 COIL CHOKE 3.3 μ H.Change A3L2 to HP Part No. 9140-0112 COIL CHOKE 4.7 μ H.

Change A4 to HP Part No. 08709-60011 BOARD ASSY AMPLIFIER.

Delete A4C6 HP Part No. 0150-0093 C:FXD .01 μ F 100V.Delete A4C8 HP Part No. 0180-0376 C:FXD ELECT 0.47 μ F 10% 35 VDCW.Add A4C20 HP Part No. 0150-0093 C:FXD .01 μ F 100V.

Add A4C21 HP Part No. 0160-2259 C:FXD 12 pF.

Add A4C22 HP Part No. 0140-0190 C:FXD 39 pF 300 V.

Add A4C23 HP Part No. 0160-3448 C:FXD 1000 pF.

Add A4C24 HP Part no. 0150-0093 C:FXD .01 μ F 100V.

Delete A4CR1 HP Part No. 1901-0022 DIODE GERMANIUM 5 WIV.

Delete A4CR2 HP Part No. 1901-0179 DIODE SILICON.

Add A4CR21 HP Part No. 1901-0040 DIODE SILICON.

Add A4CR22 HP Part No. 1901-0040 DIODE SILICON.

Change A4L1 to HP Part No. 9140-0112 COIL CHOKE 4.7 μ H 10%.

CHANGE 5
(Cont'd)

Page 6-7, Table 6-1.

- Change A4L2 to HP Part No. 9140-0112 COIL CHOKE 4.7 μ H 10%.
- Add A4L20 HP Part No. 9100-1624 COIL CHOKE 30 μ H 10%.
- Add A4L21 HP Part No. 9140-0112 COIL CHOKE 4.7 μ H 10%.
- Add A4Q4 HP Part No. 1854-0404 TRANSISTOR NPN.
- Change A4R9 to HP Part No. 0698-3440 R:FXD MET FLM 196 OHM 1% 1/8 W.
- Delete A4R11 HP Part No. 0757-0442 R:FXD MET FLM 10K 1% 1/8 W.
- Add A4R20 HP Part No. 0757-0280 R:FXD MET FLM 1K 1% 1/8 W.

Page 6-11, Table 6-1.

- Change A8C1 to HP Part No. 0160-0174 C:FXD .47 μ F 25 V.

Page 6-18, Table 6-2.

- Change HP Part No. 08709-0003 to HP Part No. 08709-00007 COVER UPPER P.C. HOUSING.

Page 7-3, Figure 7-3.

- Change A2TP1 identification from LEVEL DETECTOR to SWITCH BIAS.

Page 7-9/7-10, Figure 7-6c.

- Change A1C13 and C14 to 0.47 μ F.
- Change waveform at HELIX OUTPUT J2 search signal period 8-14 msec and an amplitude of 11-18 volts.

Page 7-11/7-12, Figure 7-7b.

- Change A3C3 to 82 pF.
- Change A3L1 to 3.3 μ H.
- Change A3L2 to 4.7 μ H.

Page 7-13/7-14, Figure 7-8a and Figure 7-8b.

- Change Figure 7-8a to the attached Figure 7-8a.
- Change Figure 7-8b to the attached Figure 7-8b.

Page 7-21/7-22, Figure 7-12b.

- Change A8C1 to 0.47 μ F.

CHANGE 6

Page 3-3, Figure 3-2:

Add

NOTE

A rear-panel jack INJECTION LOCK INPUT has been added to allow injection locking of the internal 20 MHz oscillator to an external 20 MHz \pm 200 Hz signal of 0.1 Vrms to 2.5 Vrms level.

Change HELIX OUTPUT to ERROR SIGNAL OUTPUT.

Delete SERVO OUTPUT jack.

Change three-position slide switch to MOD. SENS.

1.0 MHz/VOLT

2.5 MHz/VOLT

6.0 MHz/VOLT

Page 7-17/7-18, Figure 7-10b:

- Use the attached Figure 7-10b in place of Figure 7-10b in the manual.

CHANGE 7

Page 6-9, Table 6-1.

- Change A6L2 to HP Part No. 08709-80001.

►CHANGE 8: Page 6-13, Table 6-1.
 Change XF1 parts identification to read as follows:

Reference Designation	HP Part No.	Description
XF1	2110-0470 2110-0465 2110-0467 2190-0037 1400-0090	FUSEHOLDER-EXTR POST 20A 200V UL/IEC FUSEHOLDER-CAP UL/IEC .25X1 .25 FUSE NUT, HEX SINGLE CHAMFER 1/2-28 THREAD WASHER-LK INTL T NO. 1/2 .512 IN ID .789 WASHER: RUBBER 5/8" OD

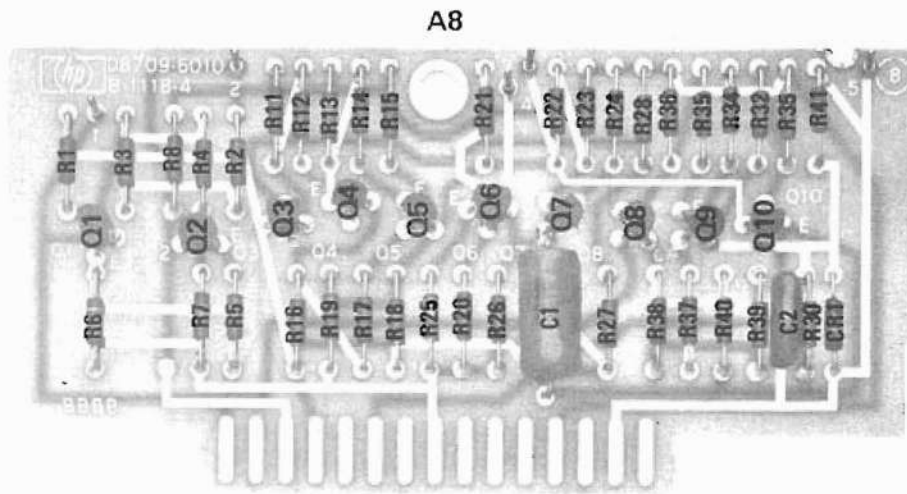

Figure 7-12a. A8 Search Generator Board Assembly Component Identification and Location (Change 4)

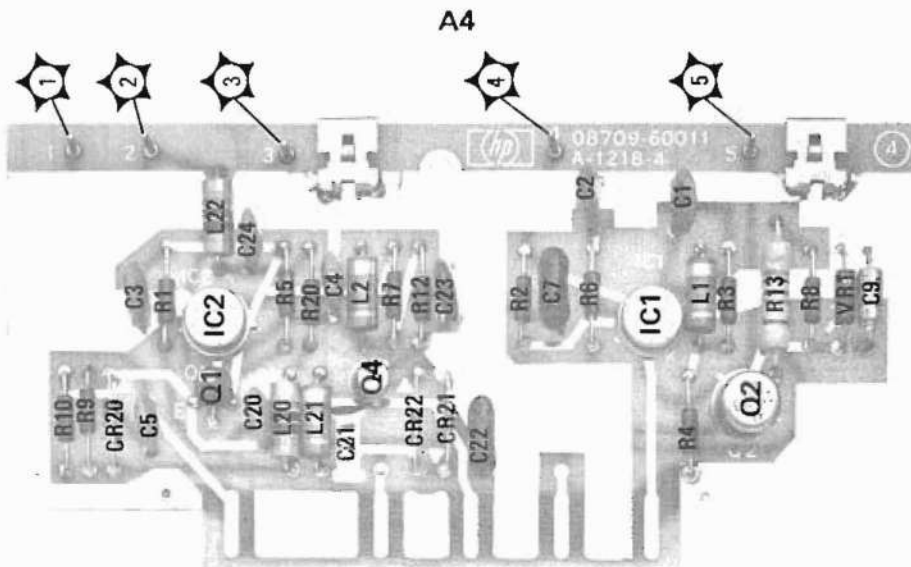
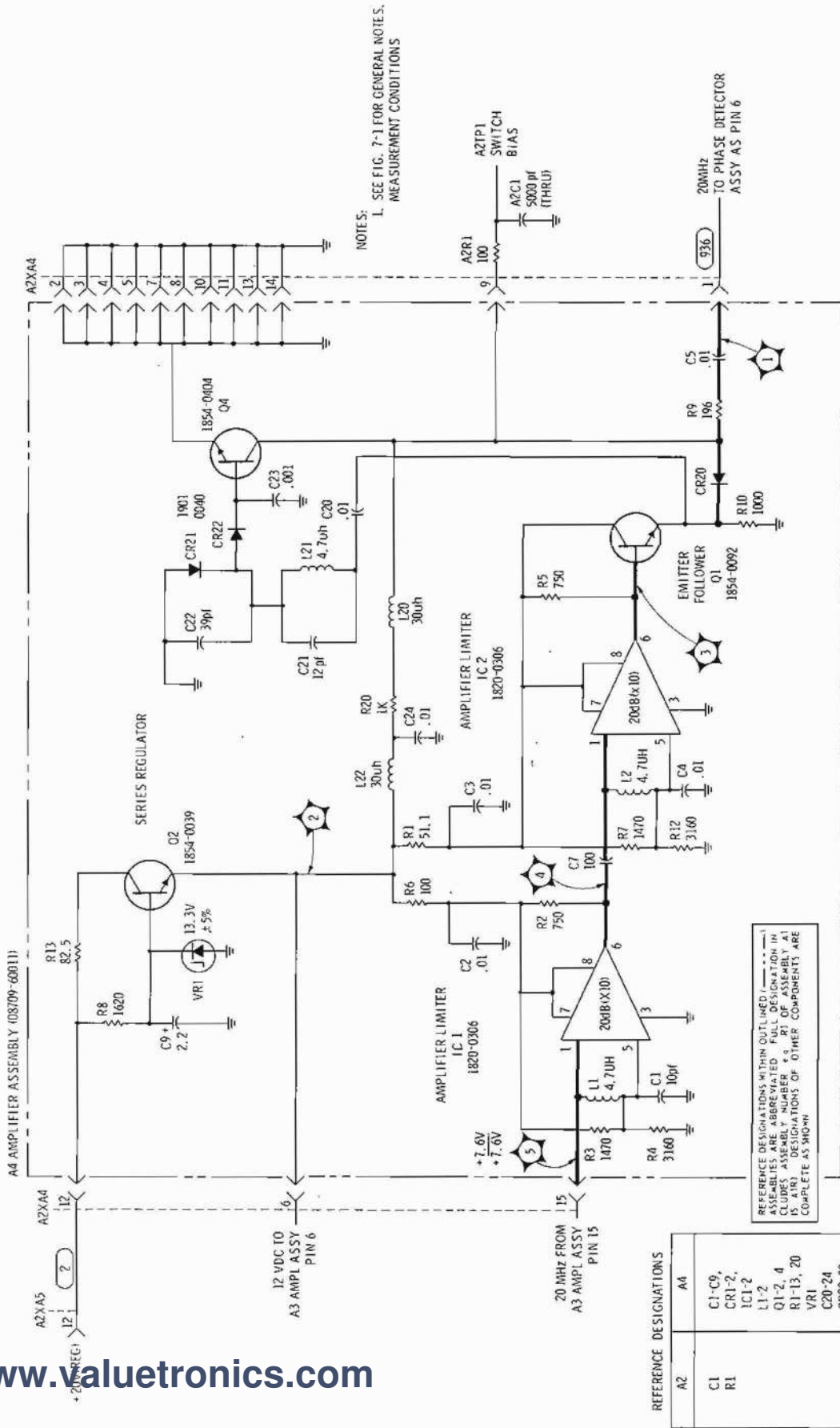

Figure 7-8a. A4 Amplifier Board Assembly Component Identification and Location (CHANGE 5)



REFERENCE DESIGNATIONS WITHIN OUTLINED ASSEMBLIES ARE ABBREVIATED. FULL DESIGNATION IN CLIPPER ASSEMBLY NUMBER #S RI OF ASSEMBLY A1 COMPLETE AS SHOWN.

REFERENCE DESIGNATION	A4
C1-C9	
CR1-2	
IC1-2	
Q1-2, 4	
R1-13, 20	
VR1	
C20-24	
CR20-22	
L20, 21	

Figure 7-8b. A4 Amplifier Board Assembly Limiter Schematic, 8709A (CHANGE 5)

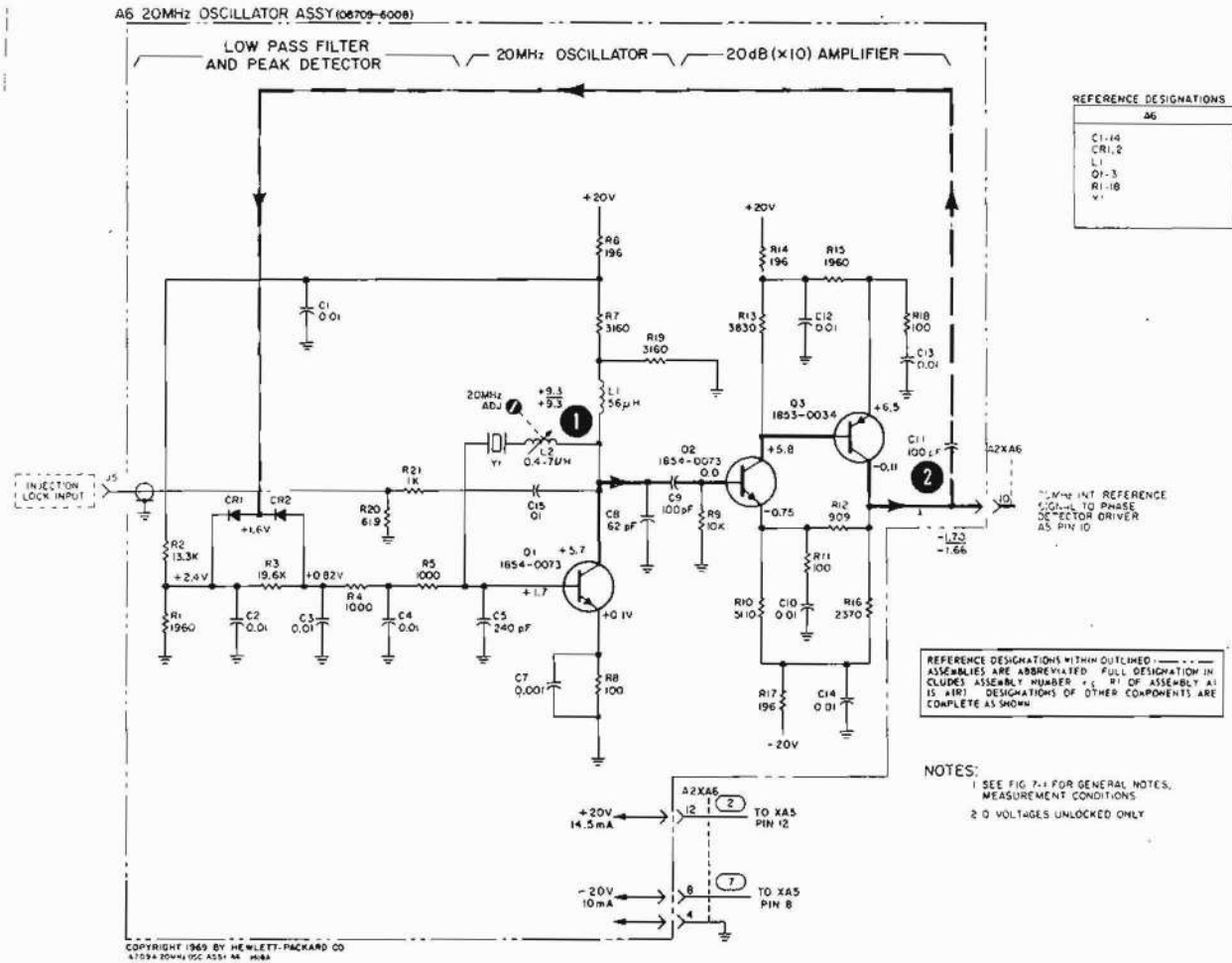

Figure 7-10b. A6 20 MHz Oscillator Board Assembly Schematic, 8709A (CHANGE 6)

HEWLETT  PACKARD

OPERATING AND SERVICE MANUAL

MODIFICATIONS

PHASE-LOCK SYNCHRONIZER
8709A-H10

SERIAL NO. PREFIX
1646A AND ABOVE

MODIFICATION PART NO.
08709-90035
OCTOBER 1977
REVISION I: JANUARY 1978

USE THIS SUPPLEMENT
WITH MANUAL PART NO.
08709-90004
PRINTED: JUNE 1969

0-500140SR

www.valuetronics.com

DESCRIPTION:

The HP 8709A-H10 Phase-Lock Synchronizer is similar to a standard 8709A except for the following changes:

- 1) Internal Oscillator Frequency is 21.4 MHz.
- 2) Error Output Voltage polarity is either + or -, selectable from a front panel switch.

These modifications enable the 8709A-H10 to be used with the 8565A Spectrum Analyzer and the 8620C/86290A Sweeper Source in a phase-locked Spectrum Analyzer System. In all other respects the 8709A-H10 is identical to a standard unit.

MANUAL CHANGES:

Page 1-1. General Information:

Change all references to 20 MHz to 21.4 MHz. (This applies throughout the Manual.)

Page 1-1. Table 1-1. Specifications:

Add to Input Frequency, "(Option H10): 21.4 MHz".

Add to Internal Oscillator Frequency, "(Option H10): 21.4 MHz \pm 1.0 kHz."

Page 3-2. Figure 3-1. 8709A-H10 Front Panel Controls and Indicators:

Add Item "5. \pm Error Voltage Switch (lower, center)."

Page 4-2. Figure 4-1. Functional Block Diagram:

Add the following to the HELIX OUTPUT:

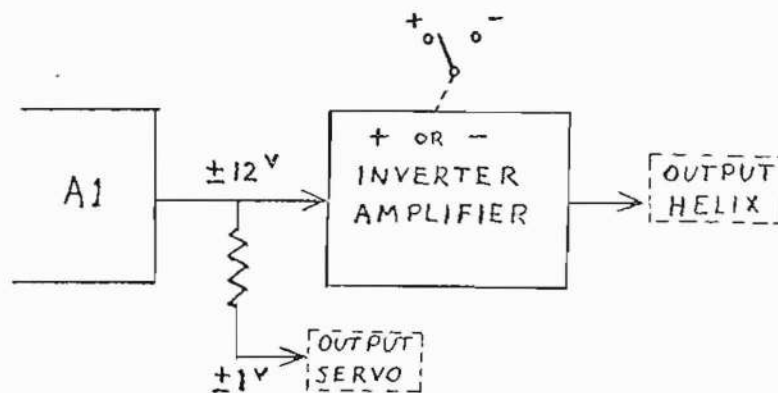

MANUAL CHANGES (Continued):

Page 6-9. Table 6-1. Reference Designation Index:

Change: A6 from 08709-6008 to 08709-60053 Oscillator
 Assembly: 21.4 MHz.

Change: A6Y1 from 0410-0159 to 08709-20024 Crystal: 21.4 MHz

Page 6-12. Table 6-1. Add the following:

REFERENCE	HP PART NO.	QTY	DESCRIPTION
A101	08709-60048	1	± Inverter Amplifier Assy.
A101C1, 3, 4	0160-4084	3	C:FXD .1µf 100V
A101C2	0160-0134	1	C:FXD 220 pf ±5%
A101R1, 2, 4	0757-0438	3	R:FXD 5.11K 1% .125W
A101R3	0698-3260	1	R:FXD 464k 1% .125W
A101R5, 6	0698-3156	2	R:FXD 14.7k 1% .125W
A101Q1	1855-0020	1	Trans: J-FET N-Chan
A101U1	1826-0081	1	IC: Lin Amplifier
A101VR1, 2	1902-0041	2	Diode: Zener 5.11V ± 5%

Add: S101 3101-0163 Switch: Sub-mini toggle, SPDT

Page 6-14. Table 6-1:

Change Item #10 from 08709-00006 to 08709-00024, Front Panel,
 Option H10

Page 7-5. Figure 7-4b. Main Chassis and Sub-Chassis Wiring
 Schematic, A2 Casting:

Add the following between Output Amp and Helix Output:

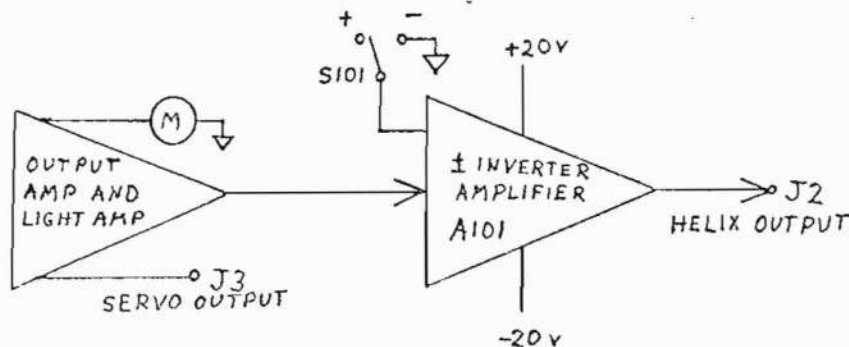

www.valuetronics.com

Change A6 Assy to 21.4 MHz Oscillator Assy

PRINTED IN U.S.A.

MANUAL CHANGES (Continued):

Page 7-10. Figure 7-6c. A1 Power Supply/Amplifier Assy

Add the following schematic at the Helix Output of the A1 Board:

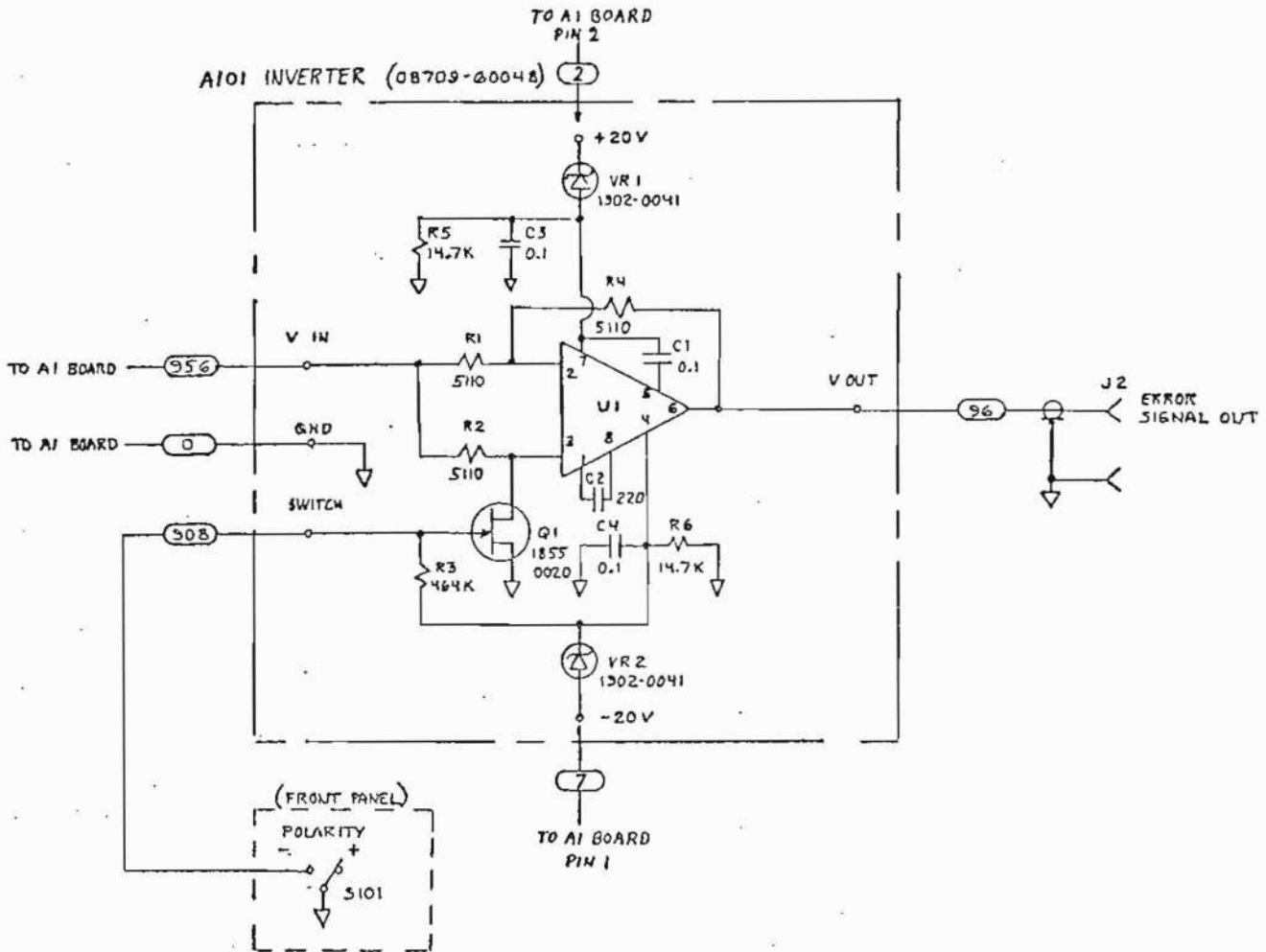

Also add the following A101 Component Location Diagram:

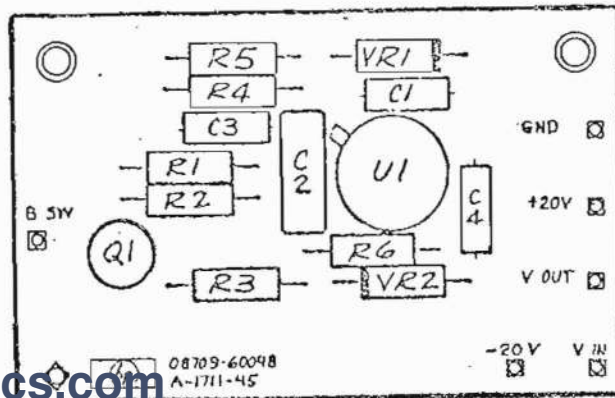

PRINTED IN U.S.A.

MANUAL CHANGES (Continued):

Page 7-18. Figure 7-10b. A6 Oscillator Board Assembly:

Change all references to 20 MHz to 21.4 MHz.

Change Board Part No. from 08709-6008 to 08709-60053.

SYNCHRONIZER 8709A

SERIAL PREFIX: 741-, 837-

Copyright HEWLETT-PACKARD COMPANY 1969
1501 PAGE MILL ROAD, PALO ALTO, CALIFORNIA, U.S.A.

08709-90004 Printed: JUNE 1969

HEWLETT  PACKARD

TABLE OF CONTENTS

Section	Page	Section	Page
I GENERAL INFORMATION	1-1	V Maintenance (Contd)	
1-1. Introduction	1-1	5-22. Power Supply Troubleshooting . .	5-5
1-6. Instrument Identification	1-1	5-28. Input Amplifiers A3/A4	
1-8. Arrangement of Manual	1-2	Troubleshooting	5-7
II INSTALLATION AND PREPARATION		5-30. Phase Detectors Troubleshooting	5-7
FOR USE	2-1	5-32. 20-MHz Oscillator Assembly	
2-1. Initial Inspection	2-1	Troubleshooting	5-7
2-3. Installation	2-1	5-34. Troubleshooting the Lock-Mode	
2-4. Power Requirements	2-1	Sensor and Search Disable	
2-6. Power Cable	2-1	Trigger	5-8
2-8. Mounting	2-1	5-36. Troubleshooting the Search	
III OPERATING INSTRUCTIONS	3-1	Signal Generator and Search	
3-1. Controls and Indicators	3-1	Disable Switch	5-8
3-4. Connections for System		5-39. DC Amplifiers Troubleshooting .	5-8
Operation	3-1	5-42. Light Amplifier Troubleshooting .	5-8
3-7. Operating Procedure	3-1	5-44. Isolating Transistor Malfunctions .	5-9
IV CIRCUIT OPERATION DESCRIPTION . . .	4-1	5-49. Out-of-Circuit Transistor	
4-1. Introduction	4-1	Testing with Ohmmeter	5-9
4-6. Overall Functional Description . .	4-1	5-51. Repair and Replacement	5-9
4-13. Detailed Functional Description . .	4-20	5-53. Etched Circuit Board Repair . . .	5-9
4-15. Solid State Devices Information . .	4-20	5-56. Component Replacement	5-11
4-16. Transistor Theory	4-20	5-58. Transistor Replacement	5-13
4-19. Transistor Circuits	4-20	5-61. Diode Replacement	5-13
V MAINTENANCE	5-1	5-65. Special Repair and Replace-	
5-1. Introduction	5-1	ment Information	5-13
5-3. Performance Testing	5-1	5-68. Adjustments	5-14
5-5. Overall Performance Test	5-1	5-71. Phase Error Meter Adjustment .	5-14
5-7. Input Sensitivity Test	5-2	5-74. Adjustment of the Search	
5-10. Helix Output Test	5-2	Oscillator Filter	5-14
5-12. Servo Output Test	5-3	5-75. Procedures after Repair and	
5-14. Frequency Range Switch Check .	5-3	Maintenance	5-14
5-16. Preventive Maintenance	5-5	VI REPLACEABLE PARTS	6-1
5-18. Troubleshooting	5-5	6-1. Introduction	6-1
5-20. Circuit Troubleshooting	5-5	6-3. Ordering Information	6-1
		VII SCHEMATIC DIAGRAMS	7-1
		7-1. Introduction	7-1

LIST OF TABLES

Number	Title	Page	Number	Title	Page
1-1.	Specifications	1-1	5-7.	Typical A5 Test Point DC Voltages	5-8
3-1.	Frequency Range of Sweep Oscillator		5-8.	Typical A8 Test Point DC Voltages	5-8
	versus Suggested Harmonic of		5-9.	Typical A7 Test Point DC Voltages	5-9
	Reference Oscillator	3-5	5-10.	8709A Transistor Base-Emitter-	
5-1.	Test Equipment Required for		Collector Typical Voltages	5-10	
	Performance Testing and		5-11.	Typical Transistor Resistance	
	Troubleshooting	5-1	Values	5-11	
5-2.	Typical A2 Test Point Voltages (vdc) . .	5-5	5-12.	Safe Ohmmeter Ranges for	
5-3.	Power Supply Specifications	5-5	Transistor Resistance		
5-4.	Typical A1 Test Point DC Voltages . .	5-5	Measurements	5-11	
5-5.	Assembly Removal Sequence and Effect		5-13.	Etched Circuit Soldering Equipment . . .	5-12
	on Power Supply Current Drain	5-7	6-1.	Reference Designation Index	6-2
5-6.	Typical A3 and A4 Test Point		6-2.	Replaceable Parts	6-15
	DC Voltages	5-7	6-3.	Code List of Manufacturers	6-20

LIST OF ILLUSTRATIONS

Number	Title	Page	Number	Title	Page
1-1.	Model 8709A Synchronizer	1-0	5-5.	Functional Troubleshooting Flow Chart	5-6
2-1.	Steps to Place Instrument into Combining Case	2-2	5-6.	Typical Current Limiting Curve	5-7
2-2.	Mounting Sub-Module Units into Adapter Frame	2-2	6-1.	Cabinet Parts	6-14
3-1.	8709A Front Panel Controls and Indicators	3-2	7-1.	General Information on Schematic Diagrams	7-1
3-2.	8709A Rear Panel Controls and Indicators	3-3	7-2.	Schematic Diagram Notes	7-2
3-3.	Typical Phase-Lock System Connections	3-4	7-3.	Component and Parts Location, Interior Bottom View, A2 Casting . .	7-3
3-4.	Typical Double Lock System Connections	3-5	7-4a.	Subchassis Component and Parts Location, A2 Casting	7-4
4-1.	Functional Block Diagram	4-2	7-4b.	Main Chassis and Subchassis Wiring Schematic, A2 Casting	7-5
4-2.	Input Signal Phase Shift and Phase Detector Gate Times	4-3	7-5a.	A1 Power Supply/Amplifier Board Assembly Power Supply Component Identification and Location	7-6
4-3.	Integrated Circuit Differential Amplifier	4-3	7-5b.	A1 Power Supply/Amplifier Board Assembly Circuit Paths and Solder Pads	7-7
4-4a.	A3 Preamplifier Circuit Description Schematic	4-4	7-5c.	A1 Power Supply/Amplifier Board Assembly Power Supply Schematic, 8709A	7-7
4-4b.	A3 Preamplifier Functional Schematic .	4-5	7-6a.	A1 Power Supply/Amplifier Board Assembly Output Amplifier and Light Amplifier Component Identi- fication and Location	7-8
4-5a.	A4 Amplifier Circuit Description Schematic	4-6	7-6b.	A1 Power Supply/Amplifier Board Assembly Output Amplifier and Light Amplifier Component Identi- fication and Location	7-9
4-5b.	A4 Amplifier Functional Schematic . .	4-7	7-6c.	A1 Power Supply/Amplifier Board Assembly Output Amplifier and Light Amplifier Schematic, 8709A .	7-9
4-6a.	A5 Phase Detector Circuit Description Schematic	4-8	7-7a.	A3 Preamplifier Board Assembly Component Identification and Location	7-11
4-6b.	A5 Phase Detector Functional Schematic	4-9	7-7b.	A3 Preamplifier Board Assembly Input Amplifier and Limiter Schematic, 8709A	7-11
4-7a.	A6 20 MHz Oscillator Circuit Description Schematic	4-10	7-8a.	A4 Amplifier Board Assembly Com- ponent Identification and Location . .	7-13
4-7b.	A6 20 MHz Oscillator Functional Schematic	4-11	7-8b.	A4 Amplifier Board Assembly Limiter Schematic, 8709A	7-13
4-8a.	A7 Lock-Mode Switch Circuit Description Schematic	4-12	7-9a.	A5 Phase Detector Board Assembly Component Identification and Location	7-15
4-8b.	A7 Lock-Mode Switch Functional Schematic	4-13	7-9b.	A5 Phase Detector Board Assembly Schematic, 8709A	7-15
4-9a.	A8 Search Generator Circuit Description Schematic	4-14	7-10a.	A6 20 MHz Oscillator Board Assembly Component Identification and Location	7-17
4-9b.	A8 Search Generator Functional Schematic	4-15	7-10b.	A6 20 MHz Oscillator Board Assembly Schematic, 8709A	7-17
4-10a.	Output Amplifier/Light Amplifier Circuit Description Schematic	4-16	7-11a.	A7 Lock-Mode Switch Board Assembly Component Identification and Location	7-19
4-10b.	Output Amplifier/Light Amplifier Circuit Functional Schematic	4-17	7-11b.	A7 Lock-Mode Switch Board Assembly Schematic, 8709A	7-19
4-11a.	Power Supplies Circuit Description Schematic	4-18	7-12a.	A8 Search Generator Board Assembly Component Identification and Location	7-21
4-11b.	Power Supplies Functional Schematic	4-19	7-12b.	A8 Search Generator Board Assembly Schematic, 8709A	7-21
4-12.	Transistor Operation	4-20			
4-13.	Basic Transistor Circuits	4-21			
4-14.	Field Effect Transistor Operation . . .	4-22			
4-15.	Basic Diode Circuits	4-23			
4-16.	Typical Solid State Devices Lead Identification	4-24			
5-1.	Performance Test Setup	5-2			
5-2.	Input Sensitivity Test Setup	5-3			
5-3.	Helix Output Test Setup	5-4			
5-4.	Search Output Test Setup	5-4			



Figure 1-1. Model 8709A Synchronizer

SECTION I

GENERAL INFORMATION

1-1. INTRODUCTION.

1-2. The Model 8709A Synchronizer (Figure 1-1) is a self-contained, solid-state component instrument that is used as a phase comparator. The Synchronizer can be used to stabilize the frequency of hp BWO microwave frequency sources having the characteristics of dc voltage changes giving variation in frequency. Stabilization of microwave frequency is done through monitoring and phase-locking circuits working with highly stable low-frequency external and internal reference oscillators. When the 8709A is used as part of a system, system frequency stability is determined by the reference oscillator frequency stability.

1-3. Typically, the 8709A is used with a modified hp 8690 Sweep Oscillator that is equipped with a shunt-tube coupler, and either the hp 8464 or hp 8466 Reference Oscillator. When used with the hp multiplier and mixer, any stable reference oscillator operating in the 100 to 500 MHz range can be used as the reference oscillator.

1-4. The input to the synchronizer is the difference-frequency obtained by mixing the signal from the source to be stabilized with the multiplied output of an external reference oscillator. The synchronizer will phase-lock when the microwave frequency is 20 MHz above the reference oscillator frequency. The output of the Synchronizer is a dc voltage having a magnitude directly proportional to the phase difference between the difference-frequency input signal and the internally

generated 20 MHz oscillator signal. Two levels of dc voltage outputs are provided from the 8709A: the high level (primary) dc output can be applied to the phase-lock circuit in the modified signal source (such as the hp 8690 Series Sweep Oscillator) to stabilize the microwave frequency; low level (secondary) dc output can be used for control of an external reference oscillator servo (such as the hp 8466) when stabilizing swept signal sources.

1-5. Operating specifications for the 8709A Synchronizer are listed in Table 1-1.

1-6. INSTRUMENT IDENTIFICATION.

1-7. Information contained in this manual applies directly to Model 8709A Synchronizers having the same serial number prefixes as indicated on the title page. The first three digits of the eight-digit serial number are the serial prefix digits. If the serial prefix of your instrument is not listed on the title page, there may be differences between data in this manual and your instrument; such differences are covered in Manual Change Sheets and/or back-dating appendices included in this manual. If the Manual Change Sheet(s) (Appendices) are missing, the information applicable to your instrument can be supplied by the nearest Hewlett-Packard Sales and Service Office. (See list of offices at rear of this manual). Manual Changes may also include ERRATA details applicable to all 8709A manuals.

Table 1-1. Specifications

Input Frequency: 20 MHz	Internal Oscillator Stability: 2×10^{-6} per 24-hour period (approx)
Sensitivity: -65 dBm	20-MHz IF Leakage: $< 5 \mu\text{V}$ at helix output
Maximum Input: 1.0 V rms	Power Requirements: 115 or 230 Vac $\pm 10\%$, 50 to 400 Hz
Minimum Output Voltage: High Level: +12.0 to -12.0 Vdc Low Level: +0.8 to -0.8 Vdc	Weight: Net, 10 lb (4.5 kg). Shipping, 11 lb 10 oz (5.3 kg)
Output Impedance: High Level: $\leq 200 \Omega$ Low Level: $\leq 70 \text{k} \Omega$	Dimensions: 6-3/32 high, 7-25/32 wide, 11 deep (inches) 155 high, 190 wide, 279 deep (cm)
Modulation Sensitivity: hp BWO with Shunt-Tube Coupler, 0.5 to 6.0 MHz/V (depending on frequency range)	Lock Point Rejection: When used with the 8690 Series Sweep Oscillators, will reject lock point corresponding to microwave source 20 MHz below reference oscillator harmonic.
© Internal Oscillator Frequency: 20.0 MHz ± 1.0 kHz	

1-8. ARRANGEMENT OF MANUAL.

1-9. Following the general information in this section (I), data for Installation and Preparation for Use (II), Operating Instructions (III), Circuit Operation Description (IV), Maintenance (V), Replaceable Parts (VI), and Schematic Diagrams (VII) make up this manual. The material in this manual is designed to

assist the operator, maintenance technician, and others needing the technical data. In addition to routine maintenance information, basic semiconductor theory and circuits information is added to Section V. Both operating and maintenance personnel should become familiar with the contents of Section IV Circuit Operation Description before they attempt to do their respective jobs.

SECTION II

INSTALLATION AND PREPARATION FOR USE

2-1. INITIAL INSPECTION.

2-2. This instrument was inspected before shipment to determine that it was free of mechanical and electrical defects. The instrument should be inspected for mechanical damage as soon as it is unpacked, particularly, if the shipping carton has evidence of damage. Save all packing material until both mechanical and electrical inspections are completed.

a. Mechanical Check: Inspect the instrument for mechanical damage such as dents, broken knobs, cracked meter glass, etc. If damage to the shipping carton is evident, ask the carrier's agent to be present when unpacking and inspecting. If the instrument has suffered in-transit abuse, file a claim for damage with the carrier and contact the nearest Hewlett-Packard office. (Listing of offices is in back of this manual). The Hewlett-Packard office will arrange for repair or replacement of the instrument immediately without waiting for the damage claim against the carrier to be settled.

b. Electrical Check: As soon as practicable, an electrical check of the instrument should be made. Details on how to make a performance check is in the front portion of the Maintenance Section (V). If the instrument fails to meet the requirements of the performance check, contact the nearest Hewlett-Packard office to obtain assistance.

2-3. INSTALLATION.

2-4. POWER REQUIREMENTS.

2-5. The 8709A Synchronizer requires either 115 or 230 Vac, 50 to 400 Hz for operation. After identifying the power available to operate the instrument, select the appropriate switch position on the two-position LINE VOLTAGE selector switch that is located on the rear panel. The value of selected power voltage will be seen when the selector switch is placed in the appropriate position.

NOTE

The 8709A Synchronizer is normally shipped with a 1/4 amp slow-blow fuse installed in the fuseholder ready for 115-volt AC operation.

CAUTION

Select the proper value of line voltage power on the LINE VOLTAGE selector switch before attaching the power cord and plugging into available AC power. The selector switch first may damage the instrument (particularly if high voltage power is connected to the instrument while the selector switch is in the low power position).

The proper size fuse should be inserted into the fuse post holder in accordance with the power line voltage. The fuse post holder is mounted on the rear panel with fuse size/line voltage information marked on the rear panel adjacent to the holder.

2-6. POWER CABLE.

2-7. To protect operating personnel, the National Electrical Manufacturers' Association (NEMA) recommends that the instrument panel and cabinet be grounded. This instrument is supplied with a three-conductor power cable having a third conductor as a grounding connection. When the cable is plugged into the power receptacle, the instrument will be grounded by the offset (center) pin of the receptacle through the power cord. No additional case or panel grounding connections are needed when the supplied power cable is used with this instrument. To preserve the protection feature of the cable and receptacle, if the instrument is used with a two-contact power source outlet, use a three-prong to two-prong adapter; connecting the green lead of the adapter to a good ground connection.

2-8. MOUNTING.

2-9. The Model 8709A Synchronizer is normally supplied in its self-contained case for bench top use. If the synchronizer is to be rack mounted an hp combining case or hp adapter frame can be used.

2-10. COMBINING CASE. The combining case (HP 1051A or HP 1052A) (see Figure 2-1) will accept one or more Hewlett-Packard instruments of 7" height whose total width is less than 19 inches. Filler panels can be used when instruments do not fill the case. The combining case can be rack mounted or used as a multi-instrument bench-top case.

2-11. ADAPTER FRAME. The adapter frame (HP 5060-0797) (see Figure 2-2) will accept one or more Hewlett-Packard instruments of 7" height whose total width is less than 19 inches. Filler panels can be used when instruments do not fill the frame. The frame is assembled as follows:

a. Place the adapter frame (HP 5060-0797) on edge of bench as shown in step 1, Figure 2-2.

b. Stack the submodular units in the frame as shown in step 2. Place the spacer clamps between instruments, step 3.

c. Place spacer clamps on the two end instruments (step 4) and push the combination into the frame.

d. Insert screws on either side of frame, and tighten until submodular instruments are tight.

e. The completed assembly is ready for rack mounting.

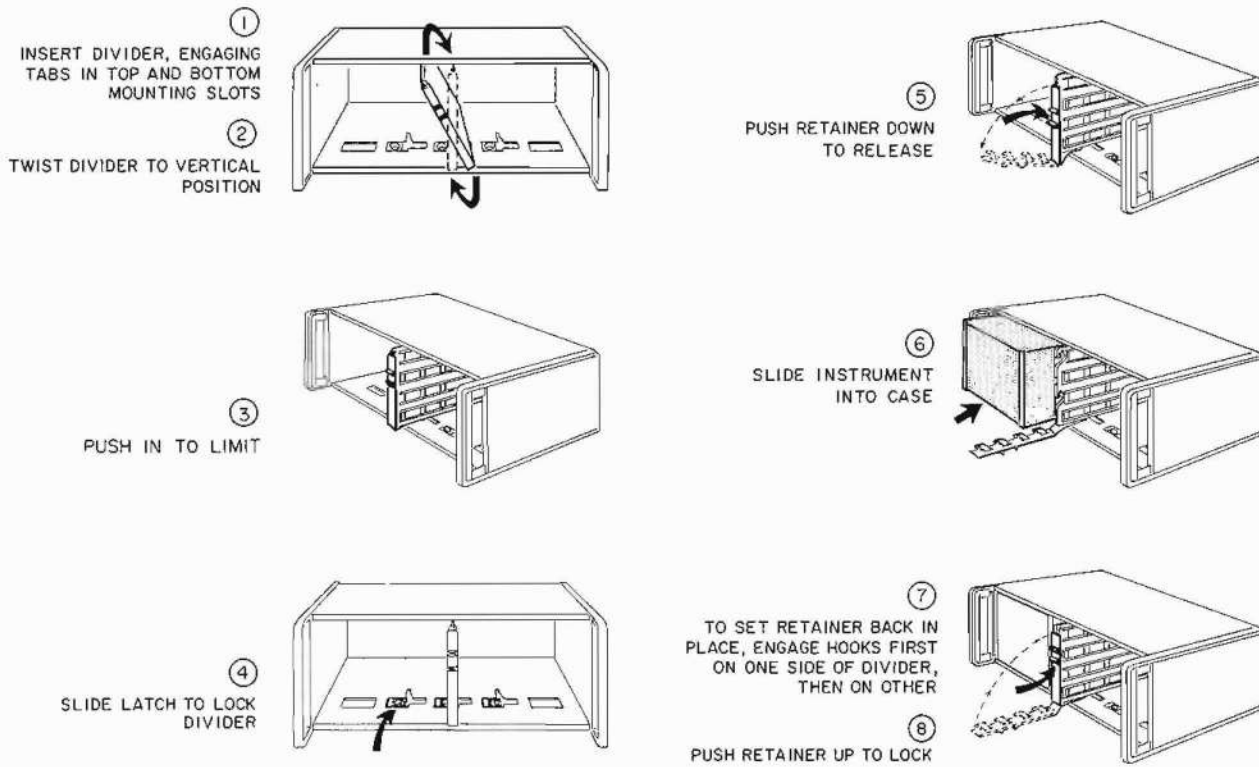

Figure 2-1. Steps to Place Instrument into Combining Case

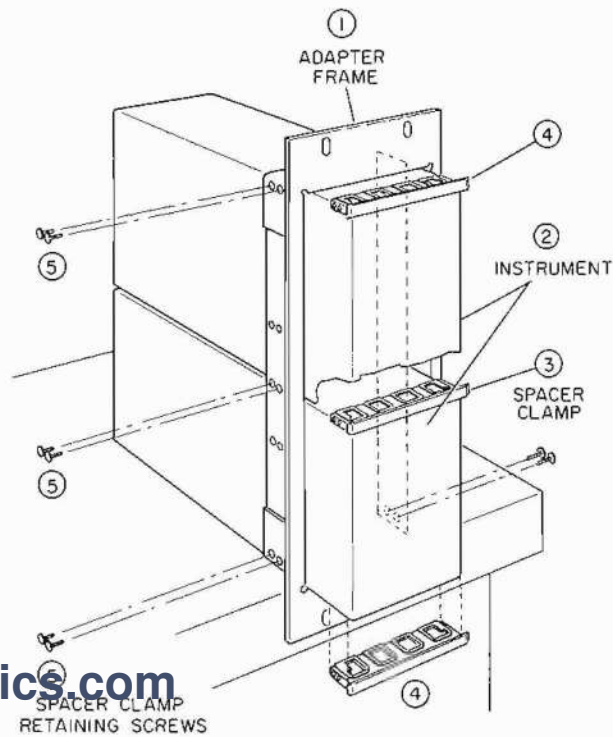

Figure 2-2. Mounting Sub-Module Units into Adapter Frame

SECTION III OPERATING INSTRUCTIONS

3-1. CONTROLS AND INDICATORS.

3-2. Operating controls and indicators on the front panel of the synchronizer are shown in Figure 3-1 and controls and jacks on the rear panel are shown in Figure 3-2. The markings adjacent to the front and rear panel mounted components are self explanatory. The UNLOCKED indicator light is "on" (lighted) when the signal is not stabilized by the synchronizer.

3-4. CONNECTIONS FOR SYSTEM OPERATION.

3-5. The 8709A Synchronizer may be used in any one of several connection configurations. Figure 3-3 shows a typical phase lock system connected to optional reference oscillators. If either the 8464 or the 8466 reference oscillators are used, Table 3-1 lists the frequency range of the sweep oscillator in relation to the suggested harmonic of the reference oscillator. Figure 3-4 shows a typical double lock system connecting two sweep oscillators using the 8709A as the synchronizing device.

3-6. The following steps are used to connect the 8709A Synchronizer in a phase lock system:

- a. Connect power cord to appropriate power.
- b. Connect RF output of mixer to INPUT connector J1 (see Figure 3-2).

NOTE

The signal source to be stabilized and the output of the reference oscillator must be combined in a mixer for Synchronizer operation.

c. Connect HELIX OUTPUT connector J2 (Figure 3-2) to the error signal input connector on the signal source to be stabilized.

d. Set the Modulation Sensitivity Switch S5, (Figure 3-2) to the position required by the signal source to be stabilized:

Position	Modulation Sensitivity
1-4 GHz	0.5 to 1 MHz/volt
4-12.4 GHz	1.0 to 2.5 MHz/volt
12.4-40 GHz	2.5 to 6.0 MHz/volt

3-7. OPERATING PROCEDURE.

3-8. To place the 8709A Synchronizer into operation in a phase lock system, proceed as follows:

- a. Place the Power toggle switch to ON (up) and observe that the POWER ON indicator light is lighted red.

NOTE

Initially the UNLOCKED indicator light may be either lighted red (indicating that phase-lock is not taking place) or the UNLOCKED indicator light may be extinguished or flickering (indicating that phase-lock has been accomplished or is near the frequency lock-point).

The PHASE ERROR meter may either be in extreme right or left swing of the needle, or may be centered, depending on the degree of phase-lock between the source and the synchronizer. After initial warmup and stabilization of the source oscillator and synchronizer oscillator, phase-lock will be indicated by the UNLOCKED indicator light being extinguished and the PHASE ERROR meter indication being on scale.

- b. Tune the microwave source to the desired frequency.

c. Tune the reference oscillator so that the UNLOCKED indicator light is extinguished (off).

- d. Fine-tune the microwave source until the PHASE ERROR meter needle is at center position.

3-9. Greater frequency accuracy and/or repeatability of the frequency of the oscillator settings can be accomplished by using a frequency counter. Because of the wide separation between lock points, the microwave frequency can be accurately determined by measuring the reference oscillator frequency and using the formula

$$f_w = f_{ref} \times (n) + 20 \text{ MHz,}$$

where

f_w = microwave source frequency

f_{ref} = reference oscillator frequency

n = harmonic of f_{ref} that is mixed with f_w

to produce 20 MHz.

www.valuetronics.com

e. When stabilizing a sweep source, connect SERVO OUTPUT connector J3 to the error signal input connector of the stabilizing system reference oscillator (such as the hp 8466) for servo control.

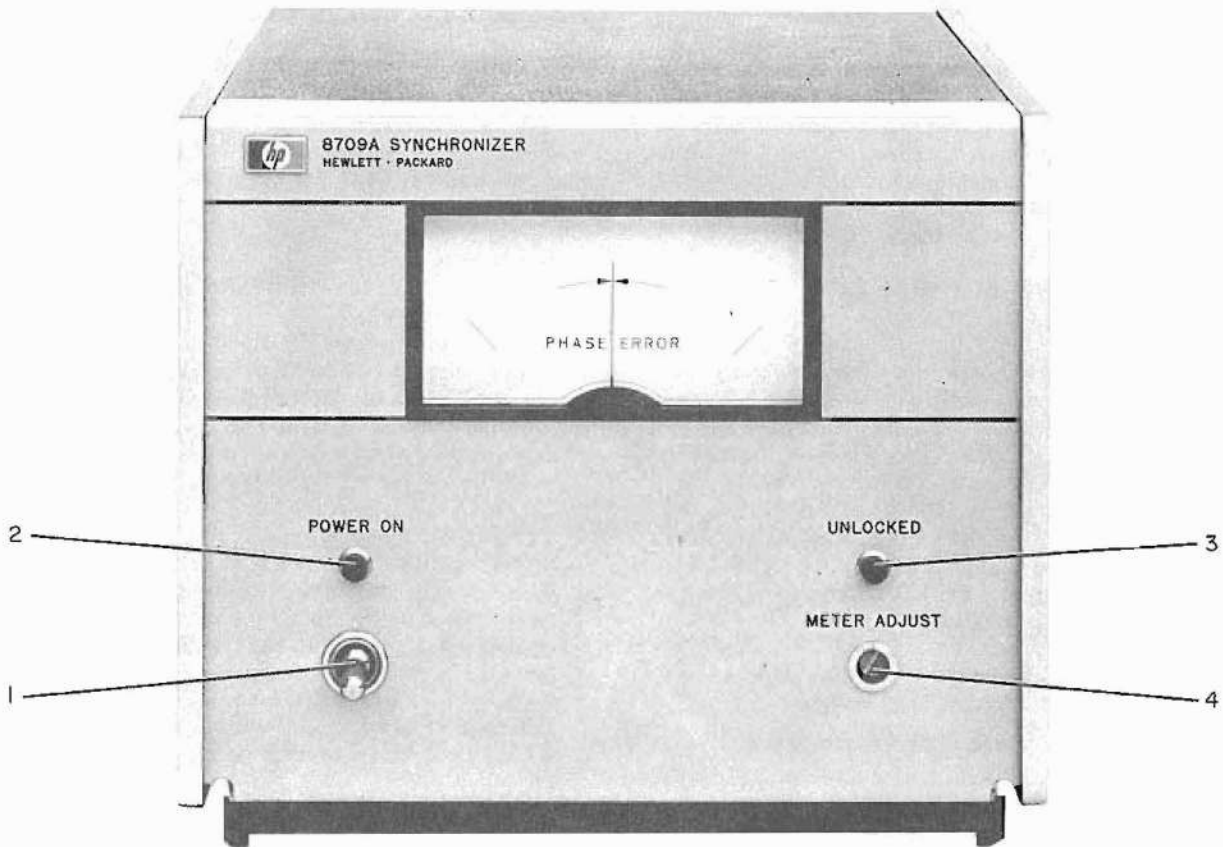

1. Power ON OFF Toggle Switch
2. POWER ON indicator lamp
3. Phase-Lock indicator lamp
4. METER ADJUST Potentiometer Shaft

www.valuetronics.com

Figure 3-1. 8709A Front Panel Controls and Indicators

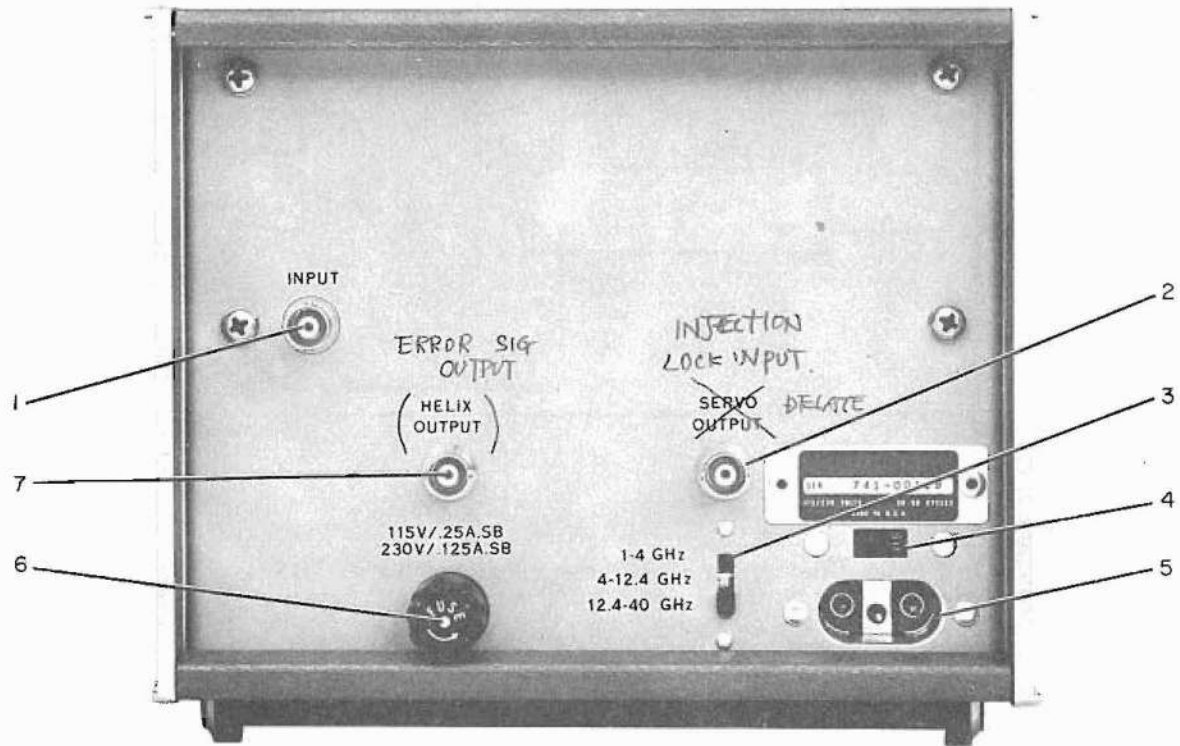

1. INPUT JACK (J1) (A2J1)
2. SERVO OUTPUT JACK (J3)
3. FREQ RANGE SELECTOR SWITCH (S2)
4. LINE VOLTAGE SELECTOR SWITCH (S3)
5. LINE CORD RECEPTACLE (J4)
6. FUSE HOLDER (XF1)
7. HELIX OUTPUT JACK (J2)

Figure 3-2. 8709A Rear Panel Controls and Indicators

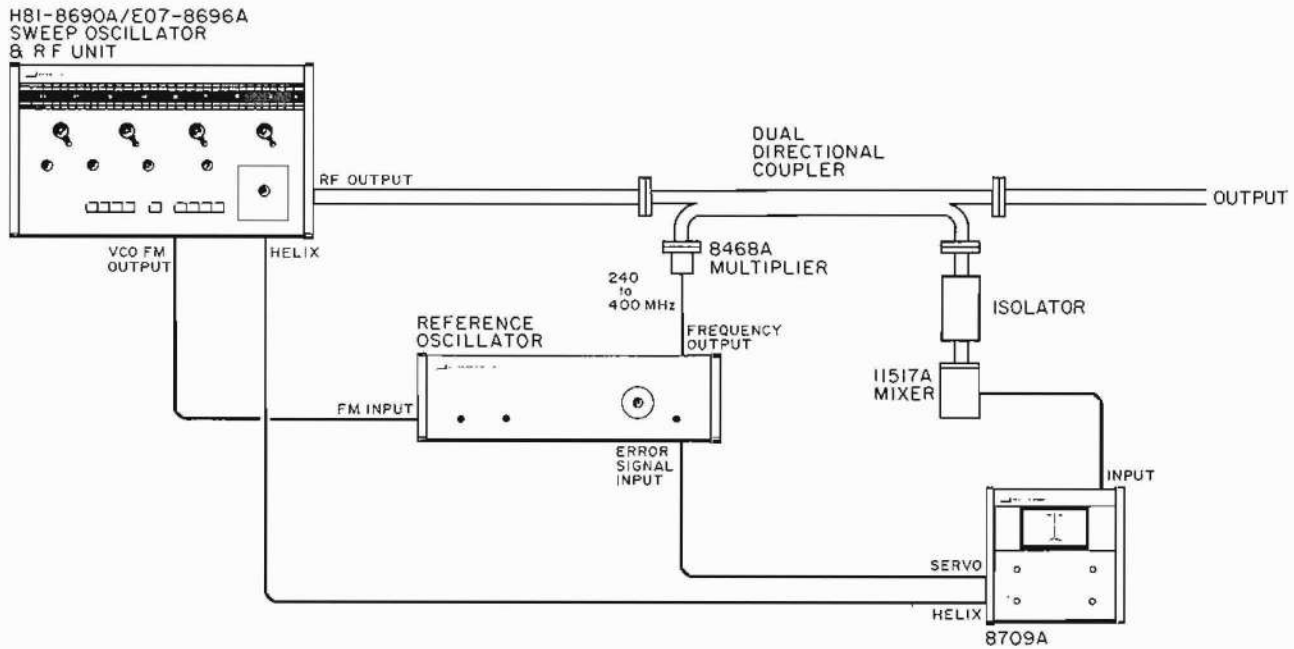

* Reference Oscillator may be any stable oscillator (100-500 MHz, 30-500 mw power out) furnished by customer or any of the following:

OPTIONAL REFERENCE OSCILLATOR

8464 Reference Oscillator

8466 Reference Oscillator

608F VHF Signal Generator

*(8708A Synchronizer to stabilize 608)

5105/5110 Synthesizer with 8467 Amplifier

Figure 3-3. Typical Phase-Lock System Connections

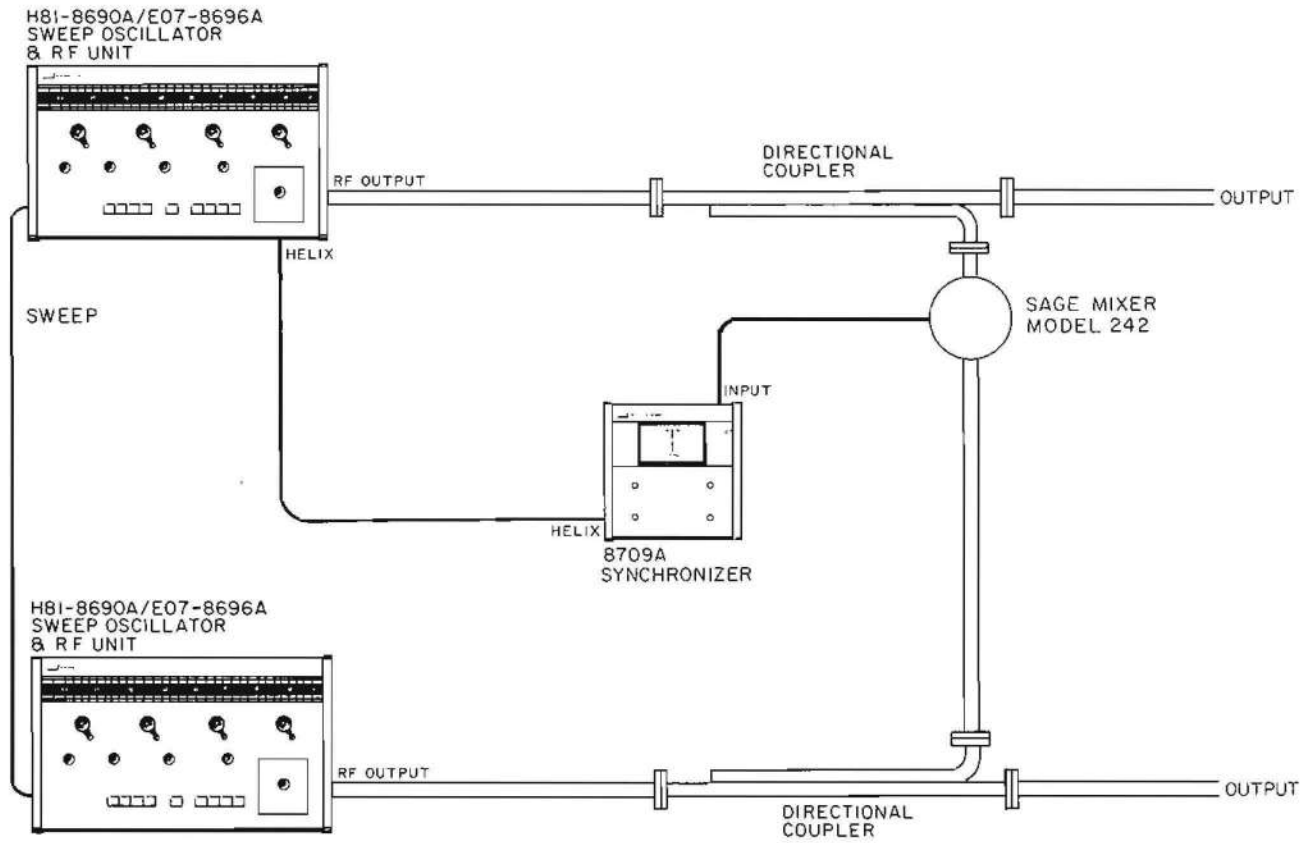

Figure 3-4. Typical Double Lock System Connections

Table 3-1. Frequency Range of Sweep Oscillator versus Suggested Harmonic of Reference Oscillator

Frequency Range of Sweep Oscillator	Suggested Harmonic of Reference Oscillator
1 - 1.5 GHz	4 th
1.5 - 2.0 GHz	6 th
2.0 - 3.0 GHz	8 th
3.0 - 4.0 GHz	12 th
4.0 - 6.0 GHz	16 th
6.0 - 8.0 GHz	24 th
8.0 - 12.4 GHz	32 th
12.4 - 18.0 GHz	50 th
18.0 - 26.5 GHz	70 th
26.5 - 40.0 GHz	100 th

www.valuetronics.com

SECTION IV

CIRCUIT OPERATION DESCRIPTION

4-1. INTRODUCTION.

4-2. The basic components of a typical frequency stabilizing system are shown in Figure 4-1. The H81-8690A Sweep Oscillator is the source to be stabilized; the 8466A Reference Oscillator provides stabilization to the sweep oscillator when phase-locked to the sweep oscillator; the 8468A Multiplier generates harmonics of the reference oscillator in the microwave frequency range. The 11517A Mixer generates the sum and difference of the microwave source frequency and the reference oscillator harmonic frequency. The output from the mixer is essentially the difference frequency derived from the source to be stabilized and the reference oscillator harmonic. The difference frequency is applied to the input of the 8709A Synchronizer. If the difference frequency is not at 20 MHz and the proper phase, the synchronizer generates a triangular search signal that is applied to the error signal input of the microwave signal source to vary the source frequency. As the microwave source output frequency changes and the signal applied to the synchronizer passes through 20 MHz, a phase detector circuit in the synchronizer produces a voltage proportional to the phase difference between the 20 MHz input signal and an internally generated 20 MHz signal. When the proper phase (microwave source 20 MHz above the reference oscillator) of the two signals is reached, the search generator is removed, and the phase detector voltage is applied to the microwave source as a correction voltage to hold its output at a frequency that will keep the synchronizer input at 20 MHz. A second phase error signal provided by the synchronizer is applied to the reference oscillator servo control (when using an 8466A) circuits when stabilizing swept frequency sources, enabling the reference oscillator to track this swept source.

4-3. Operation of the 8709A Synchronizer is extremely simple because phase-lock and error signal generation are accomplished automatically. Correct positioning of the Modulation Sensitivity selector switch on the rear panel is the only manual operation. Once the synchronizer is connected to a signal stabilizing system, the frequency of the signal source set, and the front panel Power switch is set to the ON position, operation of the Synchronizer is automatic. While operating, the synchronizer automatically accepts 20-MHz input signals, establishes phase-lock, and generates an error voltage required to maintain the signal source at its selected frequency. If the signal source and external reference oscillator frequency settings are changed, the synchronizer again accepts only a 20-MHz input signal and generates an error voltage to maintain the signal source at its new selected frequency. As soon as the signal source frequency drifts beyond the synchronizer phase-lock range, the synchronizer automatically generates a search signal

output to tune the signal source until phase-lock is reestablished. The front panel UNLOCKED indicator indicates synchronized operation. If the synchronizer has not established a lock point and is transmitting a search signal to the signal source, the UNLOCKED indicator is lighted. When the synchronizer establishes a lock-point and is not transmitting a search signal to the signal source, the UNLOCKED indicator is extinguished (not lighted).

4-4. The front panel PHASE ERROR meter indicates the correction voltage required to maintain phase-lock. When the signal source is properly stabilized and centered in the synchronizer lock-range, the output of the synchronizer is close to zero volts and the PHASE ERROR meter pointer is at or near its center position. When the signal source has drifted to the edge of the lock-range, the error signal output from the synchronizer is at maximum voltage and the PHASE ERROR meter pointer is either at its far left or far right position indicating up to 90° maximum phase error.

4-5. The synchronizer rejects the lock point in which the reference oscillator harmonic is 20 MHz above the microwave signal frequency. This feature causes the lock points to be separated by an amount equal to the reference oscillator frequency rather than twice the 20-MHz IF frequency, thus improving the ease of locking at the desired harmonic of the reference oscillator. As a result, the microwave frequency can be measured with counter accuracy by reading the reference oscillator frequency when locked to a known harmonic.

4-6. OVERALL FUNCTIONAL DESCRIPTION.

4-7. A block diagram of the 8709A Synchronizer is shown in Figure 4-1. Power supply circuits are omitted on the block diagram for clarity but are discussed in Paragraph 4-12. As shown in Figure 4-1, 4-2, the 20 MHz signal is connected to the input terminal, J1, and applied to a bandpass filter. The filtered signal is applied to a series of four integrated circuit differential amplifiers (see Figure 4-3) that also limit the signal to remove any A. M. noise that may be present on the peaks of the signal and ensures that a constant-amplitude signal is applied through the 15- to 25-MHz bandpass filter to the two phase detectors. The output signal of the 20-MHz oscillator assembly is applied to the phase detector driver that gates the phase detector on for a 10- to 15-ns portion of the 20-MHz signal. Therefore, the output from the phase detector is a voltage whose value is dependent on the average level of the input signal during the time the phase detector diodes are gated on.

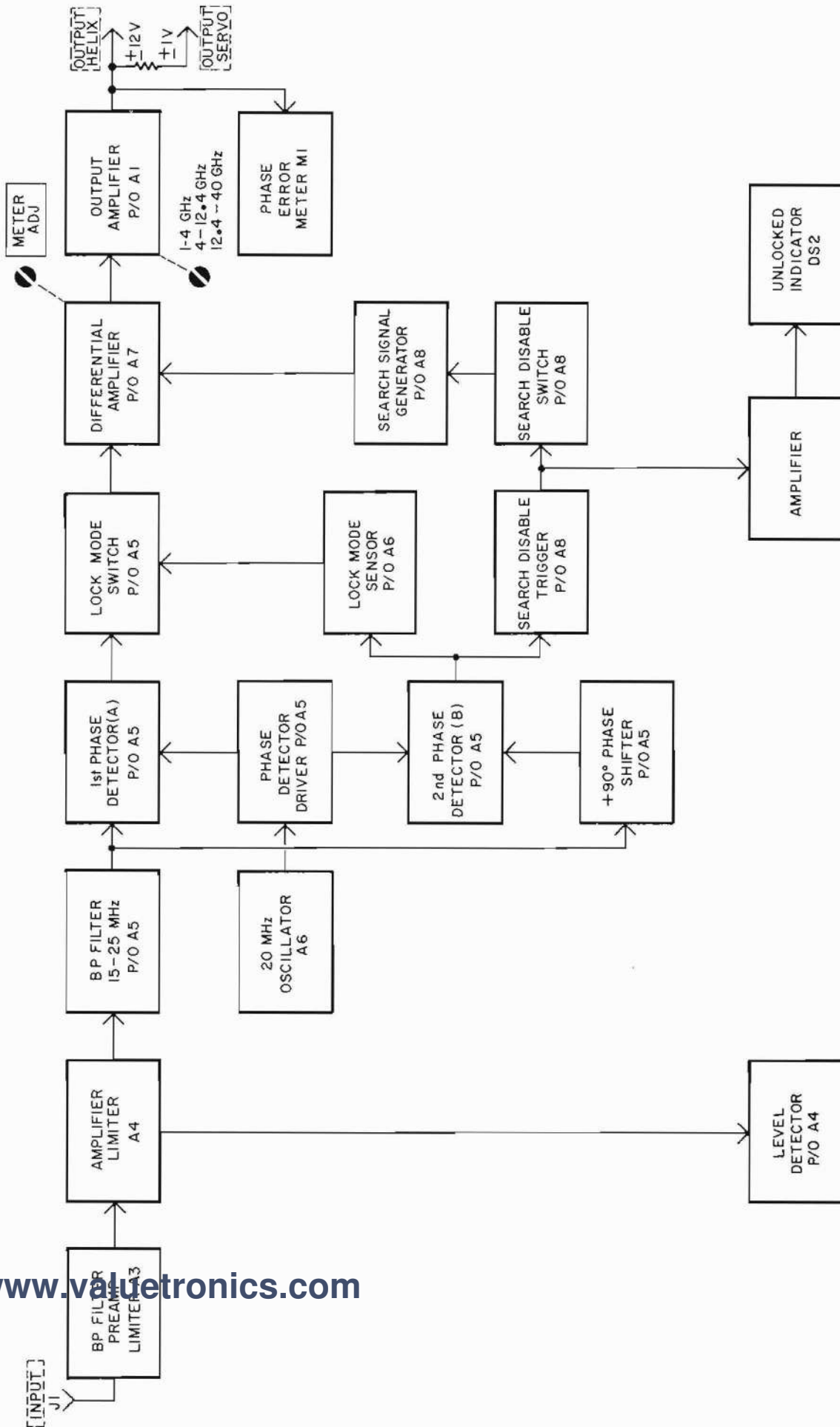

Figure 4-1. Functional Block Diagram

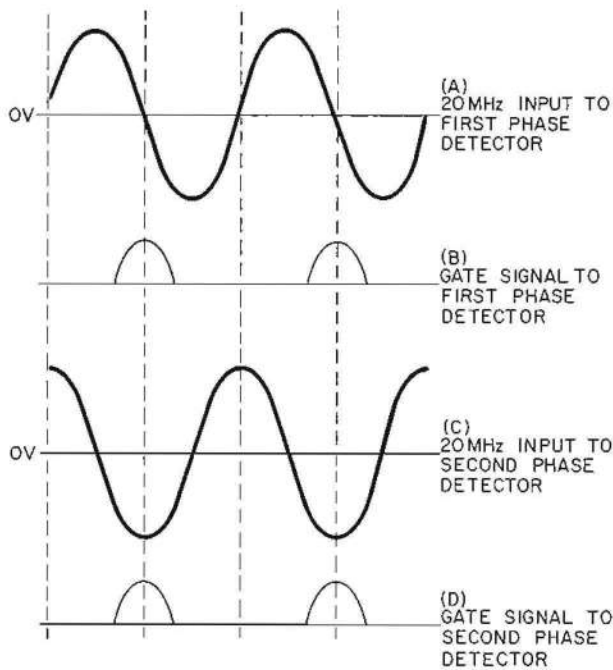

Figure 4-2. Input Signal Phase Shift and Phase Detector Gate Times

4-8. The output of the first phase detector (A) is the signal used to phase-lock the signal source to be stabilized. This phase detector output is applied through the lock mode switch, a differential amplifier, and the output amplifier back to the microwave source. The dc level of the synchronizer output is monitored by the PHASE ERROR meter. The 20-MHz input signal applied to the first phase detector is simultaneously applied through a +90-degree phase shifter to the second phase detector (B). The diodes of the second phase detector are gated on in phase with the diodes in the first phase detector. As shown in Figure 4-2, when the first phase detector is gated on at the negative-going zero voltage level of the 20-MHz input signal, the second phase detector is gated on at the maximum negative voltage level of the input signal. Conversely, if the first phase detector is gated on at the positive-going zero voltage level of the 20-MHz input signal, the second phase detector is gated on at the maximum positive voltage level of the input signal. Therefore, when the output of the first phase detector is approximately zero volts, the output of the second phase detector is either a maximum negative or maximum positive voltage level. The different voltage level outputs of the two phase detectors enable the synchronizer to reject one of the two possible lock points (reference oscillator set 20 MHz above or below desired frequency of signal source) for stabilizing the signal source. This happens when the output of the second phase detector is negative (as shown in Figure 4-2).

4-9. The output of the second phase detector is applied to the lock mode sensor and the search disable trigger. The lock mode sensor controls the lock mode switch that either blocks the output signal of the first

phase detector or applies it to a differential amplifier. The search disable trigger controls both the UNLOCKED indicator and the search disable which, in turn, controls the search signal generator. When the output of the second phase detector is more positive than approximately -0.25 volts, the search signal generator is activated, and the UNLOCKED indicator is energized. As the output of the second phase detector becomes more positive than approximately +0.2 volts, the lock mode sensor opens the lock mode switch, grounds one input of the differential amplifier, and applies the output of the search signal generator back to the signal source to change its output frequency until phase-lock is again established by the synchronizer.

4-10. If the microwave source is 20 MHz above the reference oscillator harmonic, an attempted increase in source frequency will attempt to increase the 20-MHz IF frequency (or, more precisely, to advance the phase of the 20-MHz IF with respect to the 20-MHz reference). The output of the first phase detector (as shown in Figure 4-2) will become more negative. The 8709 Helix error signal output will become more positive (due to the 180-degree phase shift through the amplifier in the A7 assembly) and the microwave source frequency will be decreased, assuming the source is an H81-8690 Series Sweep Oscillator in which there is an additional phase reversal in the shunt tube coupler circuit. These conditions are correct for phase-locking as shown in Figure 4-2.

4-11. If the microwave source is 20 MHz below the reference oscillator harmonic, an attempted increase

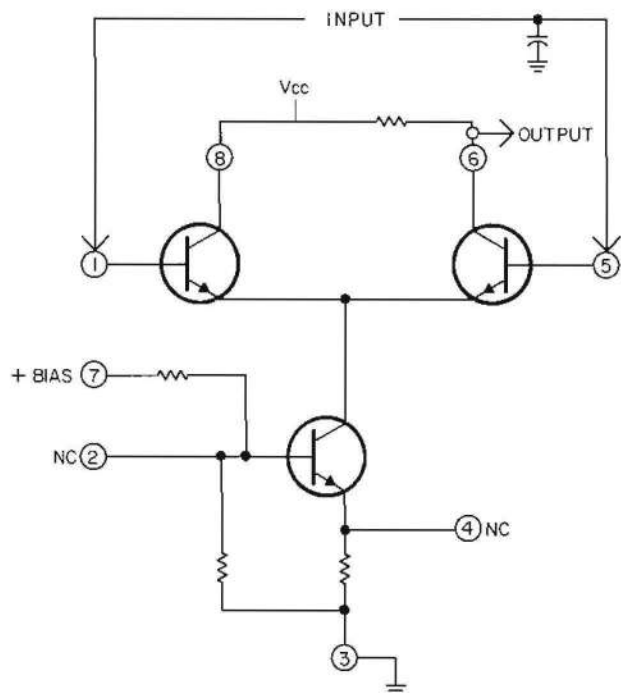

Figure 4-3. Integrated Circuit Differential Amplifier

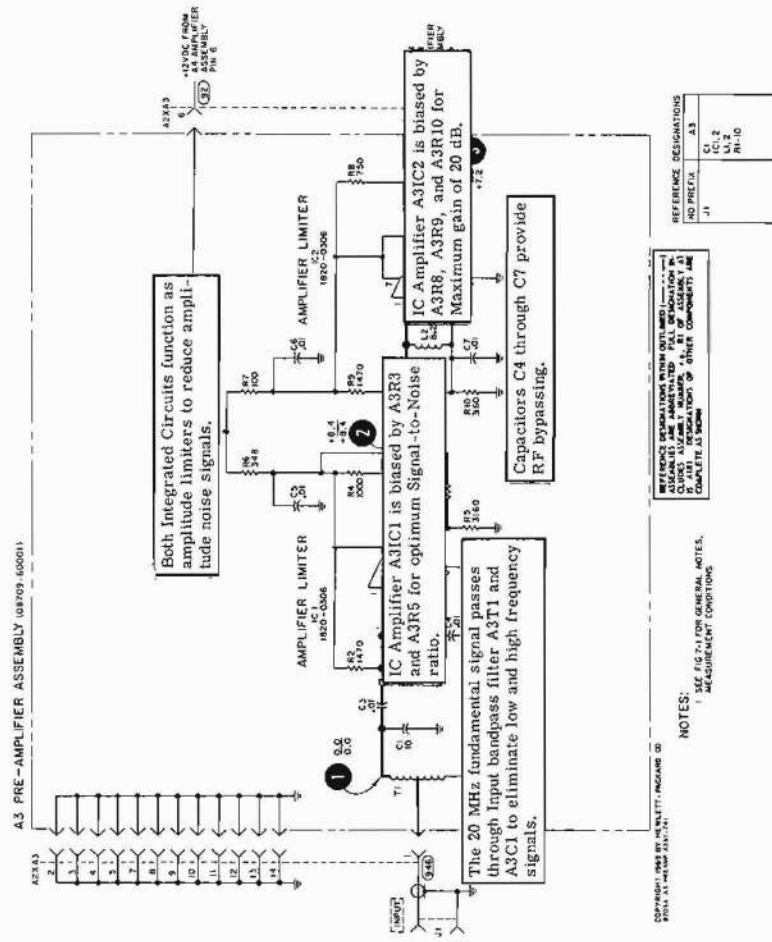

Figure 4-4a. A3 Preamplifier Circuit Description Schematic

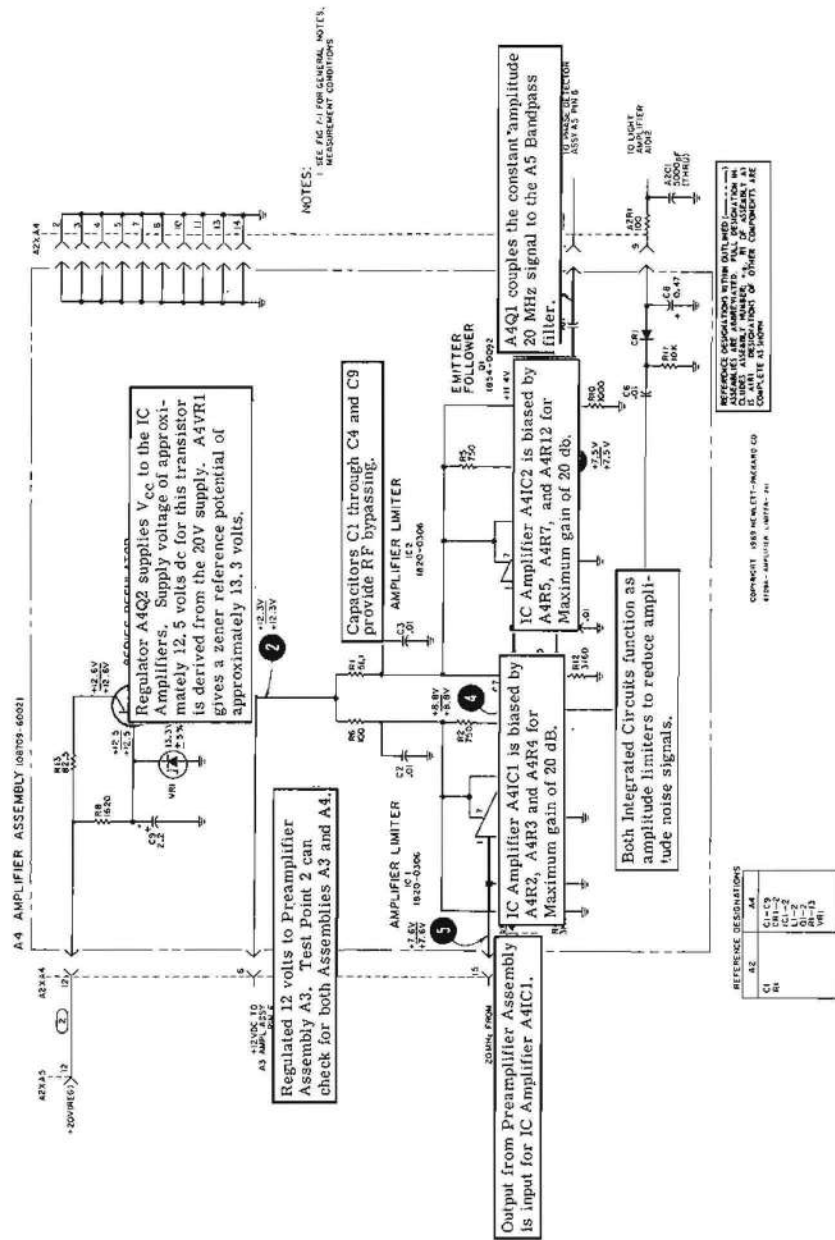
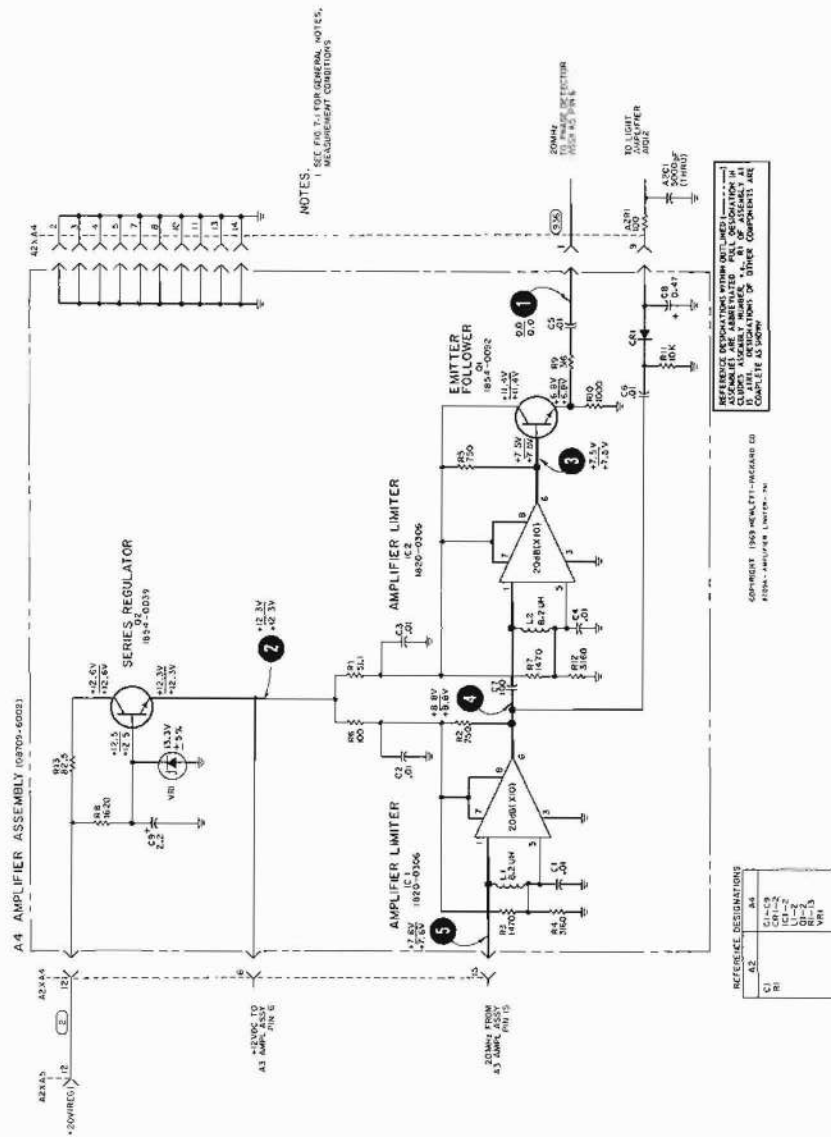
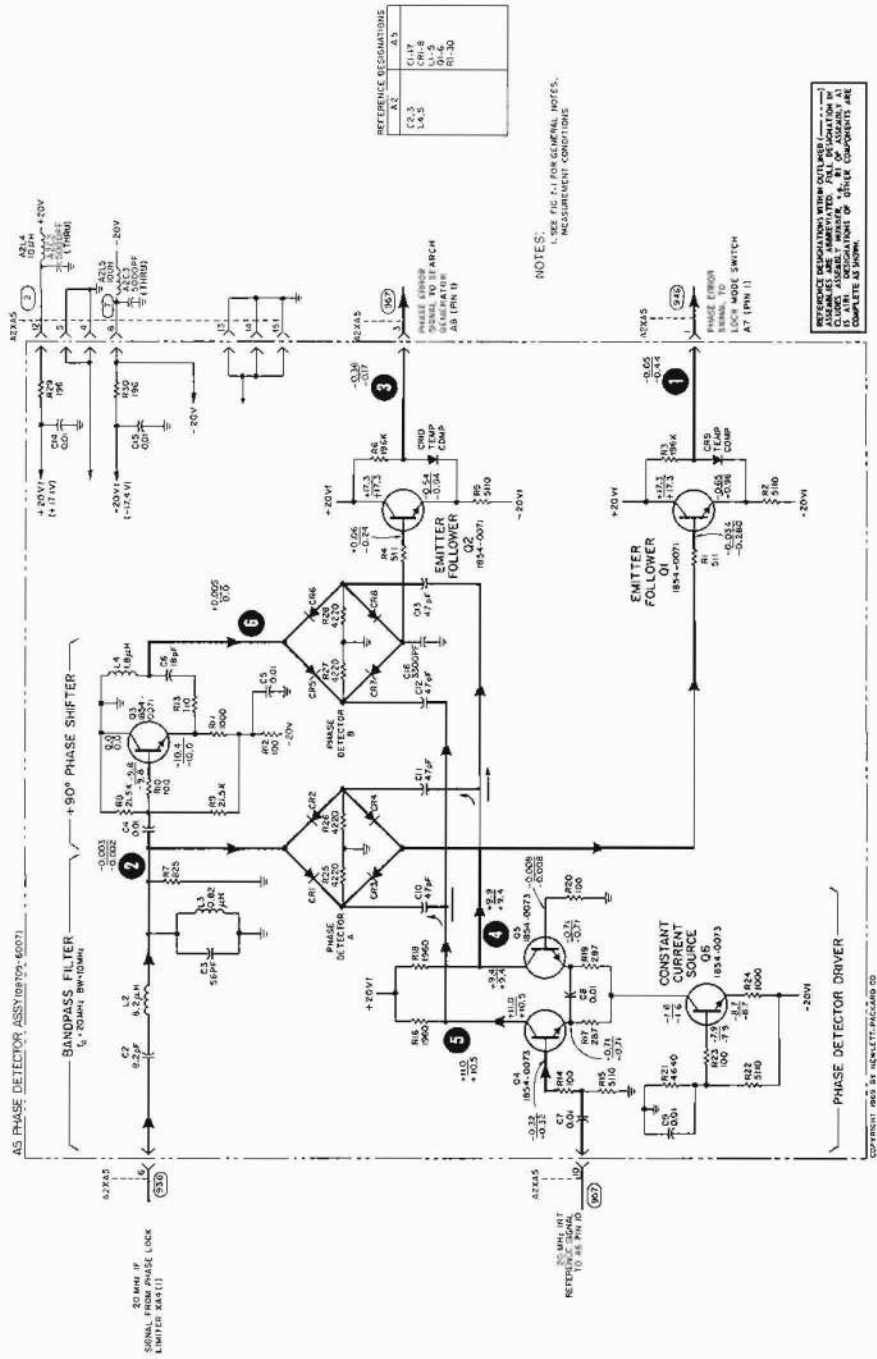
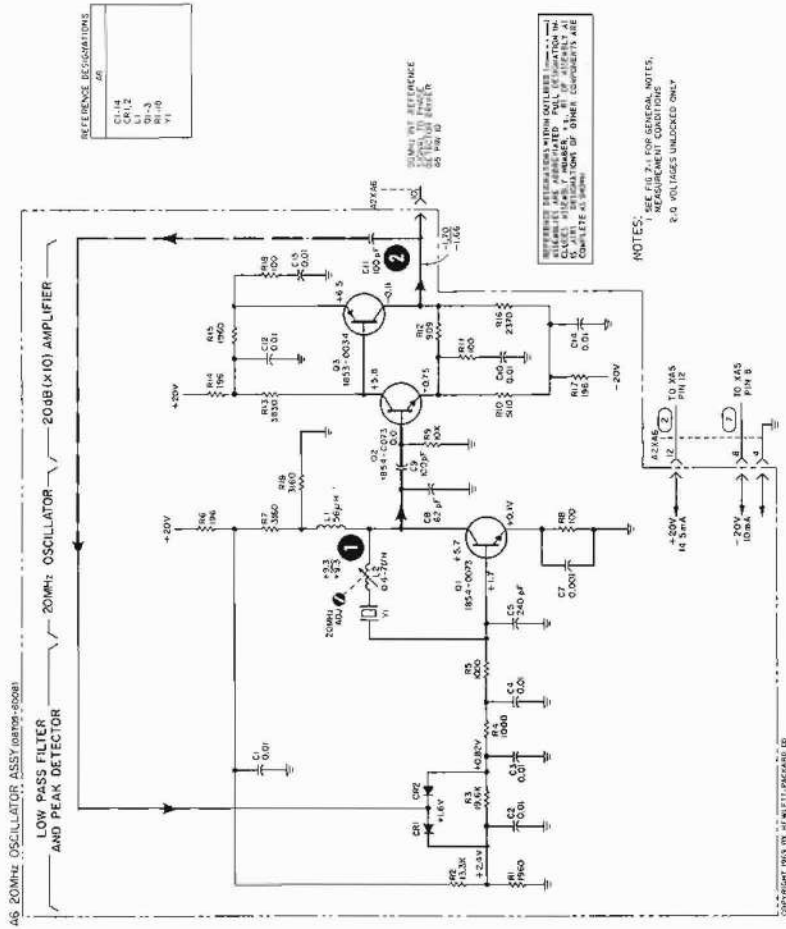

Figure 4-5a. A4 Amplifier Circuit Description Schematic





REFERENCE DESIGNATIONS	
A.2	C2.5
A.3	L4.5
	CR-B
	CR-C
	CR-D
	CR-E
	CR-F
	CR-G
	CR-H
	CR-I
	CR-J
	CR-K
	CR-L
	CR-M
	CR-N
	CR-O
	CR-P
	CR-Q
	CR-R
	CR-S
	CR-T
	CR-U
	CR-V
	CR-W
	CR-X
	CR-Y
	CR-Z
	CR-AA
	CR-AB
	CR-AC
	CR-AD
	CR-AE
	CR-AF
	CR-AG
	CR-AH
	CR-AI
	CR-AJ
	CR-AM
	CR-AN
	CR-AO
	CR-AP
	CR-AQ
	CR-AR
	CR-AS
	CR-AT
	CR-AU
	CR-AV
	CR-AW
	CR-AX
	CR-AY
	CR-AZ
	CR-BB
	CR-BC
	CR-BD
	CR-BE
	CR-BF
	CR-BG
	CR-BH
	CR-BI
	CR-BJ
	CR-BM
	CR-BN
	CR-BO
	CR-BP
	CR-BQ
	CR-BR
	CR-BS
	CR-BT
	CR-BU
	CR-BV
	CR-BW
	CR-BX
	CR-BY
	CR-BZ
	CR-CA
	CR-CB
	CR-CC
	CR-CD
	CR-CE
	CR-CF
	CR-CG
	CR-CH
	CR-CI
	CR-CJ
	CR-CM
	CR-CN
	CR-CO
	CR-CP
	CR-CQ
	CR-CR
	CR-CS
	CR-CT
	CR-CU
	CR-CV
	CR-CW
	CR-CX
	CR-CY
	CR-CZ
	CR-DA
	CR-DB
	CR-DC
	CR-DD
	CR-DE
	CR-DF
	CR-DG
	CR-DH
	CR-DI
	CR-DJ
	CR-DM
	CR-DN
	CR-DO
	CR-DP
	CR-DQ
	CR-DR
	CR-DS
	CR-DT
	CR-DU
	CR-DV
	CR-DW
	CR-DX
	CR-DY
	CR-DZ
	CR-EA
	CR-EB
	CR-EC
	CR-ED
	CR-EE
	CR-EF
	CR-EG
	CR-EH
	CR-EI
	CR-EJ
	CR-EM
	CR-EN
	CR-EO
	CR-EP
	CR-EQ
	CR-ER
	CR-ES
	CR-ET
	CR-EU
	CR-EV
	CR-EW
	CR-EX
	CR-EY
	CR-EZ
	CR-FA
	CR-FB
	CR-FC
	CR-FD
	CR-FE
	CR-FG
	CR-FH
	CR-FI
	CR-FJ
	CR-FM
	CR-FN
	CR-FO
	CR-FP
	CR-FQ
	CR-FR
	CR-FS
	CR-FT
	CR-FU
	CR-FV
	CR-FW
	CR-FX
	CR-FY
	CR-FZ
	CR-GA
	CR-GB
	CR-GC
	CR-GD
	CR-GE
	CR-GF
	CR-GG
	CR-GH
	CR-GI
	CR-GJ
	CR-GM
	CR-GN
	CR-GO
	CR-GP
	CR-GQ
	CR-GR
	CR-GS
	CR-GT
	CR-GU
	CR-GV
	CR-GW
	CR-GX
	CR-GY
	CR-GZ
	CR-HA
	CR-HB
	CR-HC
	CR-HD
	CR-HE
	CR-HF
	CR-HG
	CR-HH
	CR-HI
	CR-HJ
	CR-HM
	CR-HN
	CR-HO
	CR-HP
	CR-HQ
	CR-HR
	CR-HS
	CR-HT
	CR-HU
	CR-HV
	CR-HW
	CR-HX
	CR-HY
	CR-HZ
	CR-IA
	CR-IB
	CR-IC
	CR-ID
	CR-IE
	CR-IF
	CR-IG
	CR-IH
	CR-II
	CR-IM
	CR-IN
	CR-IO
	CR-IP
	CR-IQ
	CR-IR
	CR-IS
	CR-IT
	CR-IU
	CR-IV
	CR-IW
	CR-IX
	CR-IY
	CR-IZ
	CR-JA
	CR-JB
	CR-JC
	CR-JD
	CR-JE
	CR-JF
	CR-JG
	CR-JH
	CR-JI
	CR-JJ
	CR-JM
	CR-JN
	CR-JO
	CR-JP
	CR-JQ
	CR-JR
	CR-JS
	CR-JT
	CR-JU
	CR-JV
	CR-JW
	CR-JX
	CR-JY
	CR-JZ
	CR-KA
	CR-KB
	CR-KC
	CR-KD
	CR-KE
	CR-KF
	CR-KG
	CR-KH
	CR-KI
	CR-KJ
	CR-KM
	CR-KN
	CR-KO
	CR-KP
	CR-KQ
	CR-KR
	CR-KS
	CR-KT
	CR-KU
	CR-KV
	CR-KW
	CR-KX
	CR-KY
	CR-KZ
	CR-LA
	CR-LB
	CR-LC
	CR-LD
	CR-LE
	CR-LF
	CR-LG
	CR-LH
	CR-LI
	CR-LJ
	CR-LM
	CR-LN
	CR-LO
	CR-LP
	CR-LQ
	CR-LR
	CR-LS
	CR-LT
	CR-LU
	CR-LV
	CR-LW
	CR-LX
	CR-LY
	CR-LZ
	CR-MA
	CR-MB
	CR-MC
	CR-MD
	CR-ME
	CR-MF
	CR-MG
	CR-MH
	CR-MI
	CR-MJ
	CR-MM
	CR-MN
	CR-MO
	CR-MP
	CR-MQ
	CR-MR
	CR-MS
	CR-MT
	CR-MU
	CR-MV
	CR-MW
	CR-MX
	CR-MY
	CR-MZ
	CR-NA
	CR-NB
	CR-NC
	CR-ND
	CR-NE
	CR-NF
	CR-NG
	CR-NH
	CR-NI
	CR-NJ
	CR-NN
	CR-NO
	CR-NP
	CR-NQ
	CR-NR
	CR-NS
	CR-NT
	CR-NU
	CR-NV
	CR-NW
	CR-NX
	CR-NY
	CR-NZ
	CR-OA
	CR-OB
	CR-OC
	CR-OD
	CR-OE
	CR-OF
	CR-OG
	CR-OH
	CR-OI
	CR-OJ
	CR-OM
	CR-ON
	CR-OO
	CR-OP
	CR-OQ
	CR-OR
	CR-OS
	CR-OT
	CR-OU
	CR-OV
	CR-OW
	CR-OX
	CR-OY
	CR-OZ
	CR-PA
	CR-PB
	CR-PC
	CR-PD
	CR-PE
	CR-PF
	CR-PG
	CR-PH
	CR-PI
	CR-PJ
	CR-PM
	CR-PN
	CR-PO
	CR-PP
	CR-PQ
	CR-PR
	CR-PS
	CR-PT
	CR-PU
	CR-PV
	CR-PW
	CR-PX
	CR-PY
	CR-PZ
	CR-QA
	CR-QB
	CR-QC
	CR-QD
	CR-QE
	CR-QF
	CR-QG
	CR-QH
	CR-QI
	CR-QJ
	CR-QM
	CR-QN
	CR-QO
	CR-QP
	CR-QL
	CR-QR
	CR-QS
	CR-QT
	CR-QU
	CR-QV
	CR-QW
	CR-QX
	CR-QY
	CR-QZ
	CR-RA
	CR-RB
	CR-RC
	CR-RD
	CR-RE
	CR-RF
	CR-RG
	CR-RH
	CR-RI
	CR-RJ
	CR-RR
	CR-RO
	CR-RP
	CR-RQ
	CR-RR
	CR-RS
	CR-RT
	CR-RU
	CR-RV
	CR-RW
	CR-RX
	CR-RY
	CR-RZ
	CR-SA
	CR-SB
	CR-SC
	CR-SD
	CR-SE
	CR-SF
	CR-SG
	CR-SH
	CR-SI
	CR-SJ
	CR-SM
	CR-SN
	CR-SO
	CR-SP
	CR-SQ
	CR-SR
	CR-SS
	CR-ST
	CR-SU
	CR-SV
	CR-SW
	CR-SX
	CR-SY
	CR-SZ
	CR-TA
	CR-TB
	CR-TC
	CR-TD
	CR-TE
	CR-TF
	CR-TG
	CR-TH
	CR-TI
	CR-TJ
	CR-TM
	CR-TN
	CR-TO
	CR-TP
	CR-TQ
	CR-TR
	CR-TS
	CR-TT
	CR-TU
	CR-TV
	CR-TW
	CR-TX
	CR-TY
	CR-TZ
	CR-UA
	CR-UB
	CR-UC
	CR-UD
	CR-UE
	CR-UF
	CR-UG
	CR-UH
	CR-UI
	CR-UJ
	CR-UM
	CR-UN
	CR-UO
	CR-UP
	CR-UQ
	CR-UR
	CR-US
	CR-UT
	CR-UY
	CR-UZ
	CR-VA
	CR-VB
	CR-VC
	CR-VD
	CR-VE
	CR-VF
	CR-VG
	CR-VH
	CR-VI
	CR-VJ
	CR-VM
	CR-VN
	CR-VO
	CR-VP
	CR-VQ
	CR-VR
	CR-VS
	CR-VT
	CR-VU
	CR-VV
	CR-VW
	CR-VX
	CR-VY
	CR-VZ
	CR-WA
	CR-WB
	CR-WC
	CR-WD
	CR-WE
	CR-WF
	CR-WG
	CR-WH
	CR-WI
	CR-WJ
	CR-WM
	CR-WN
	CR-WO
	CR-WP
	CR-WQ
	CR-WR
	CR-WS
	CR-WT
	CR-WU
	CR-WV
	CR-WW
	CR-WX
	CR-WY
	CR-WZ



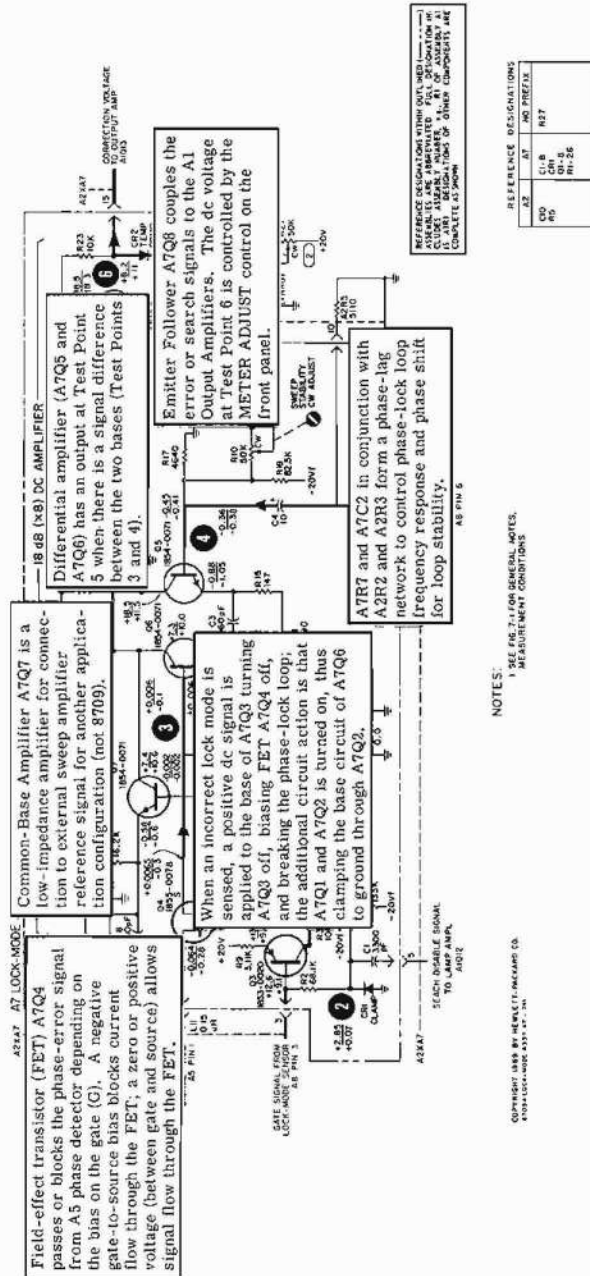

REFERENCE DESIGNATIONS

A1	A7	NO PRETYPED
A2	C1, B	R27
C10	CR	CR-5
R5	CR-5	CR-26

NOTES:
 1. SEE FIG. 7-1 FOR GENERAL NOTES, MEASUREMENT CONDITIONS.

COPYRIGHT 1969 BY HEWLETT-PACKARD CO.
 4709A LOCK-MODE SWITCH, 47-11

Figure 4-8a. A7 Lock-Mode Switch Circuit Description Schematic

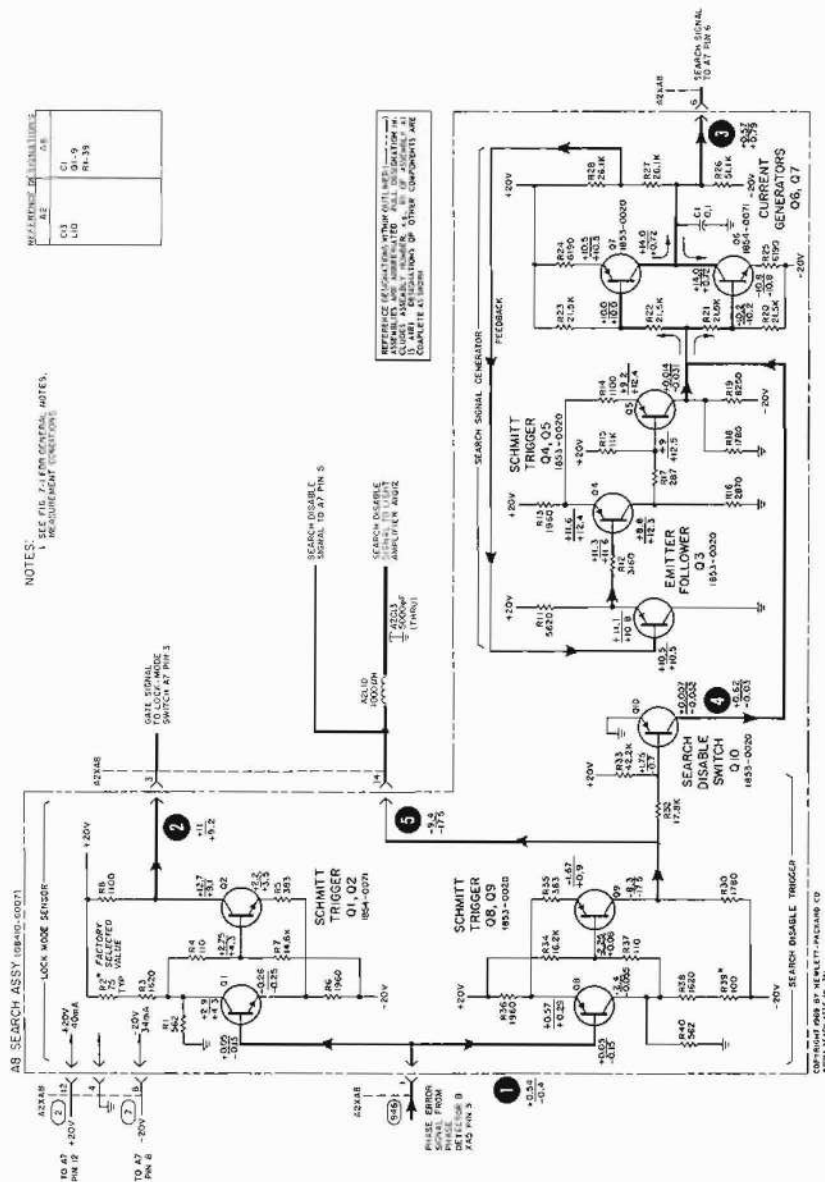

Figure 4-9b. A8 Search Generator Functional Schematic

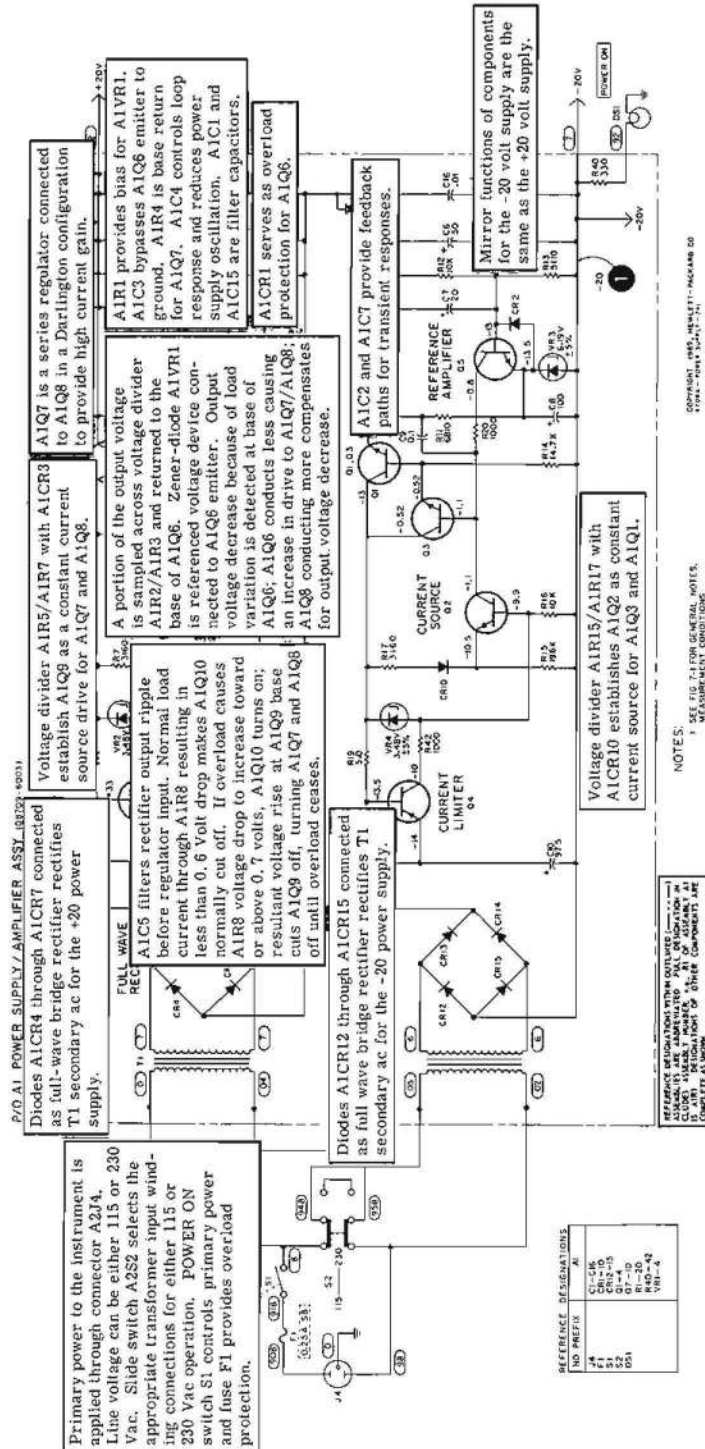

Figure 4-11a. Power Supplies Circuit Description Schematic

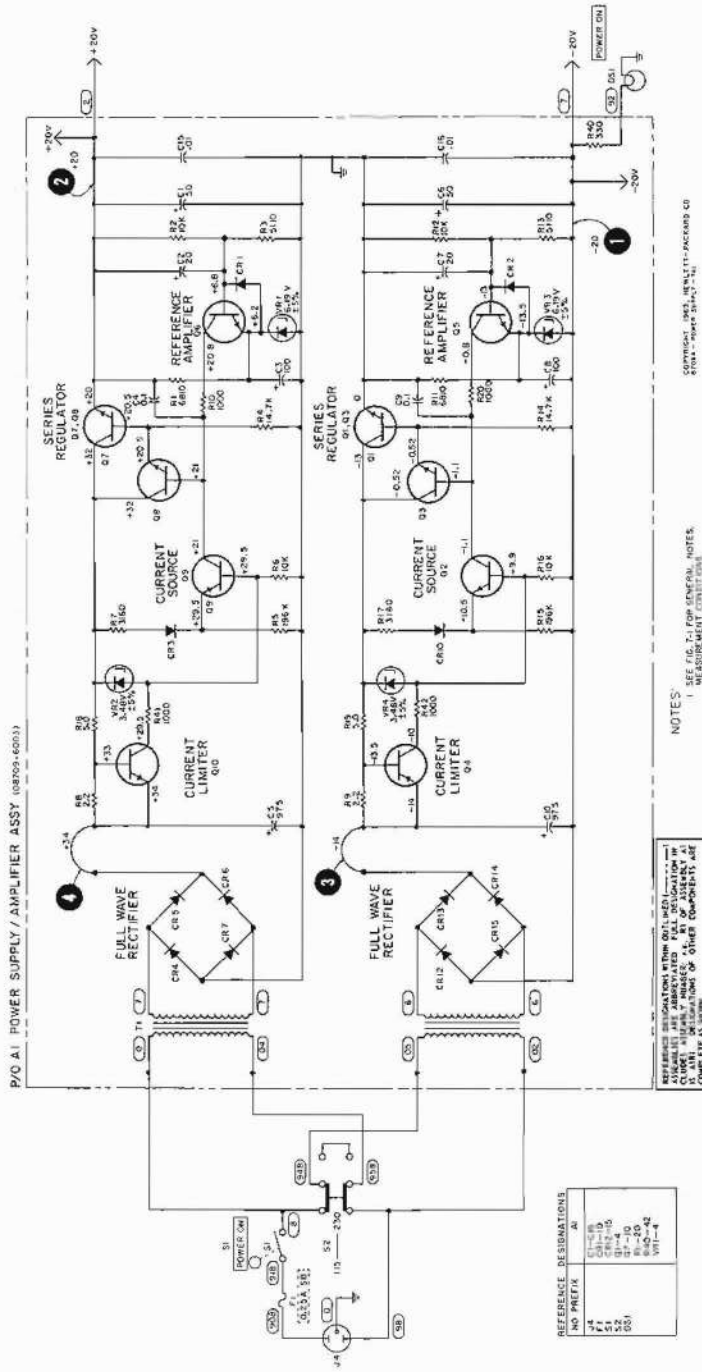

Figure 4-11b. Power Supplies Functional Schematic

in source frequency will retard the phase of the 20-MHz IF with regard to the 20-MHz reference. For phase-locking to be possible, the source frequency must be reduced. As before, this requires a negative voltage from the first phase detector. Therefore, the first phase detector must be gated on during the positive-going portion of the 20-MHz input signal. This in turn causes the output of the second phase detector to be positive and phase-lock is prevented. Therefore, the synchronizer can only phase-lock a microwave source that is tuned 20 MHz above the reference oscillator frequency being used. When this condition exists, the output of the second phase detector is negative, the search signal generator is shut off, and the lock mode switch applies the output of the first phase detector to the output amplifier.

4-12. The synchronizer power supply circuits consist of a primary power input circuit, a regulated +20 volt power supply circuit, and a regulated -20 volt power supply circuit. The primary power input circuit provides selection of the correct circuit connection for the amount of primary voltage available (115 or 230 Vac), protects the synchronizer from circuit overloads, and controls the application of power to the synchronizer circuits. The two regulated supply circuits also contain a current limiting circuit to provide additional overload protection.

4-13. DETAILED FUNCTIONAL DESCRIPTION.

4-14. Figures 4-4 through 4-11 describe the individual circuits of the 8709A Synchronizer in detail.

4-15. SOLID STATE DEVICES INFORMATION.

4-16. TRANSISTOR THEORY.

4-17. GENERAL. Transistors are used in circuit configurations such as the amplifier, the flip-flop (binary), the trigger circuit, and the one-shot multivibrator. In the following paragraphs, basic transistor operation and a few basic transistor circuits are discussed. These paragraphs discuss the easily observed changes in currents and voltages in transistor circuits which help technicians locate circuit faults but do not attempt to describe how transistors work internally.

4-18. BIASING AND CONDUCTION. In a transistor, a small base-to-emitter current controls a large collector-to-emitter current. A comparison of NPN transistor and PNP transistor operation is shown in Figure 4-12. The arrows in Figure 4-12 indicate conventional flow of positive charges external to the transistor and is not intended to indicate flow of carriers inside the transistor structure. Notice that the effect

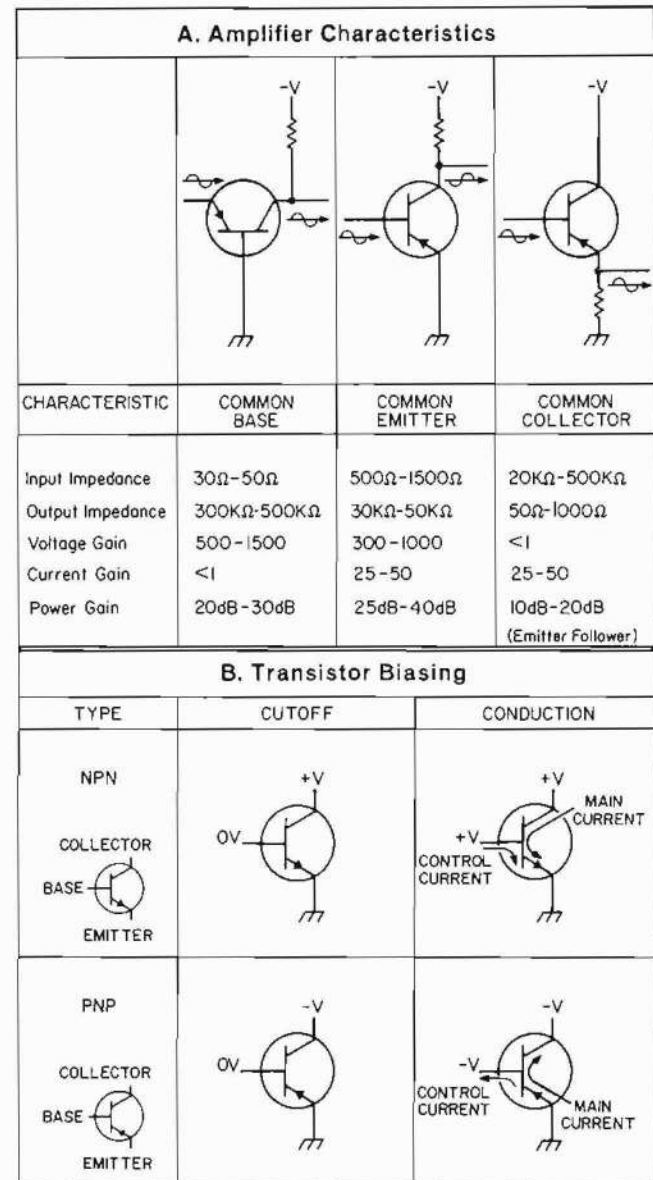

Figure 4-12. Transistor Operation

of emitter-base-collector voltages is totally reversed between NPN and PNP transistors; circuits which are arranged for an NPN transistor usually function normally for a PNP transistor if supply voltages are reversed.

4-19. TRANSISTOR CIRCUITS.

4-20. AMPLIFIERS. Three basic amplifier types are available (Figure 4-13). These amplifiers may be used alone or in combination to form complex circuits.

4-21. FLIP-FLOP. The flip-flop is a bi-stable, two-transistor circuit in which one transistor conducts, holding the other cut off. Each input pulse causes a

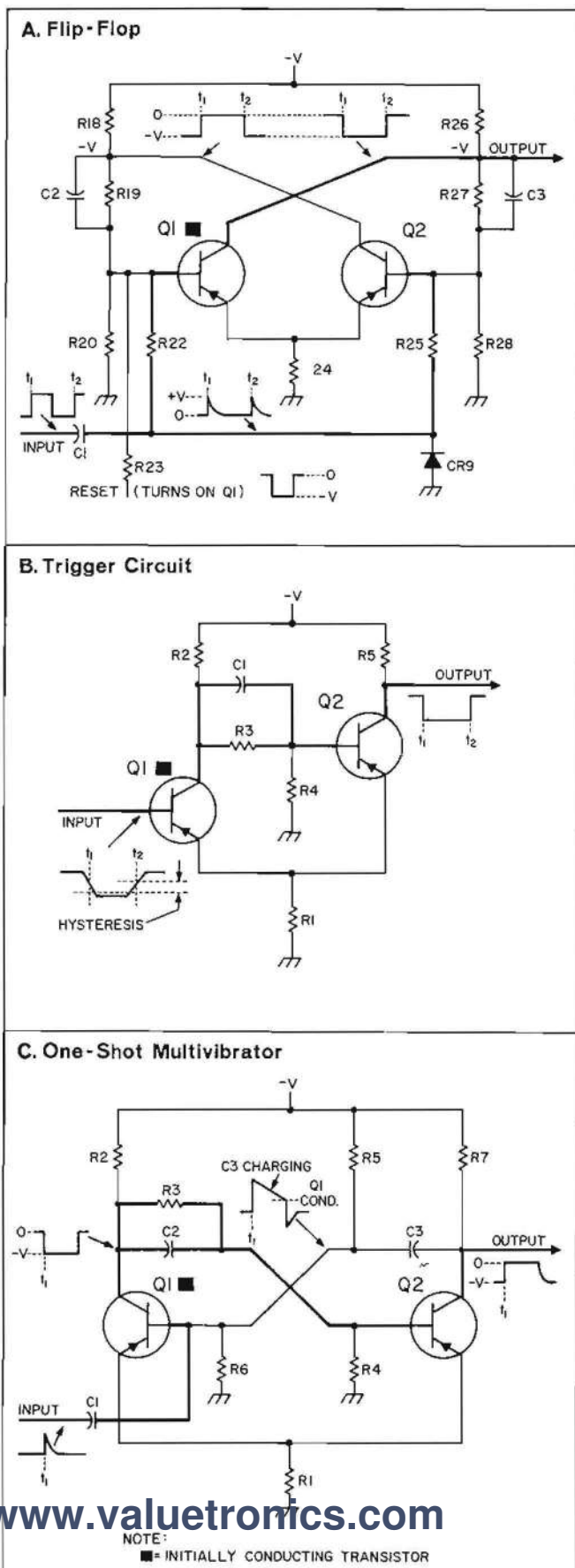

Figure 4-13. Basic Transistor Circuits

reversal of states; that is, the cut off transistor is turned on and the conducting transistor is cut off. In the flip-flop shown in Figure 4-13, Q1 is initially conducting heavily; its collector voltage is only slightly negative; a near-zero voltage is supplied to the base of Q2 (junction of R27-28 divider). The voltage drop across R24 produces a sufficiently negative voltage at the emitter of Q2 to hold Q2 cut off. With Q2 cut off, the R18-R19-R20 divider delivers a negative voltage to the base of Q1 to keep it conducting.

4-22. At time t_1 the positive input pulse cuts off Q1; the Q1 collector voltage goes negative and drives Q2 into conduction (R27-R28 divider to Q2 base); the Q2 collector voltage and the Q1 base voltage (R19-R20 divider) then become considerably less negative, permitting Q1 to remain cut off. The R26-R27-R28 divider delivers a sufficiently negative voltage to the base of Q2 to drive it into conduction. In a similar manner the positive input pulse at time t_2 cuts off Q2 and starts a sequence of events which ends with Q1 conducting and Q2 cut off. Note that a positive input pulse has no effect on Q1 if it is already cut off. A negative reset pulse applied to the base of Q1 returns the flip-flop to its initial condition (Q1 conducting, Q2 cut off). The diode CR9 removes the negative pulse from the differentiated square-wave input. Without this diode, the negative pulse would drive Q1, which is cut off, and the stage would switch from one state to the other but would not divide by two. The ac coupling through C2 and C3 insures fast switching. The dc coupling through R19 and R27 insures bi-stable characteristics.

4-23. TRIGGER CIRCUIT. The trigger circuit is a limiter or squaring circuit that produces an output waveform with very fast rise and fall times (Figure 4-13). The trigger circuit is similar to the flip-flop except that the RF network in one half is replaced by the input signal. Capacitor C1 bypasses R3 to couple fast changes in voltage at the Q1 collector to the base of Q2. Either Q1 or Q2 can conduct depending on the voltage at the input. Note that there is a slight difference in input voltage (called hysteresis) between switching with a negative-going input (time t_1) and switching with a positive-going input (time t_2).

4-24. ONE-SHOT MULTIVIBRATOR. The one-shot multivibrator is a circuit that generates a pulse of some specified duration following the application of a suitable triggering pulse. The circuit is similar to the flip-flop except one dc coupling path has been removed so the circuit is stable only in the state with Q1 conducting.

4-25. In the typical one-shot multivibrator shown in Figure 4-13, the following conditions exist during the initial stable period: R5-R6 divider delivers a sufficiently negative potential to the base of Q1 to hold Q1 in saturation; the Q1 collector and Q1 emitter are therefore slightly negative; the R3-R4 divider delivers

the Q2 base an even smaller negative voltage to hold Q2 cut off.

4-26. The positive triggering pulse at time t_1 reduces conduction of Q1; the resulting negative-going voltage at the Q1 collector is applied to the Q2 base through the R3-R4 divider (C2 bypasses R3 to provide coupling for the rapidly changing voltage at the Q1 collector); Q2 begins to conduct the resulting positive-going change in Q2 collector voltage is coupled through C3 to the Q1 base to further decrease Q1 conduction. The process is regenerative and quickly results in Q1 being cut off and Q2 being saturated.

4-27. Capacitor C3 now charges at a rate mainly determined by the values of R6 and C3 (main charge path: R1-Q2-C3-R3). When the Q1 base voltage becomes sufficiently negative, Q1 begins conduction; the resulting positive-going Q1 collector voltage is coupled to the Q2 base; the Q2 collector voltage goes negative and is coupled through C3 to the Q1 base to further increase Q1 conduction. The process is regenerative and ends with the circuit in its original quiescent state, Q1 saturated and Q2 cut off.

4-28. FIELD EFFECT TRANSISTOR (FET). Field effect transistors have three terminals; source, drain, and gate which correspond in function to emitter, collector, and base of junction transistors. Source and drain lead are attached to the same block (channel) of N or P semiconductor material. A band of oppositely doped material around the channel (between the source and drain leads) is connected to the gate lead. Figure 4-14 shows the FET's amplifier characteristic.

4-29. In normal FET operation, the gate-source voltage reverse-biases the PN junction, causing an electric field that creates a depletion region in the source-drain channel. In the depletion region, the number of available current carriers is reduced as the reverse-biasing voltage increases, making source drain current a function of gate-source voltage. With the input (gate-source) circuit reverse-biased, the FET presents a high impedance to its signal source (as compared with the low impedance of the forward-biased junction transistor base-emitter circuit). Because there is no input current, FET's have less noise than junction transistors. Figure 4-14 shows the schematic symbol and biasing for N channel and P channel field effect transistors.

4-30. LIMITER OR CLIPPER. The limiter or clipper is a circuit which removes positive or negative peaks of waveforms. It can be used either as a waveform-shaping circuit or as a protective device to prevent excessive voltages from reaching a sensitive circuit. Figure 4-15 shows a limiter which prevents the negative peak of a pulse from going more negative than about -0.6 volt. Note that for a conducting silicon diode, the cathode voltage is about 0.6 to 0.8 volt more negative than the anode.

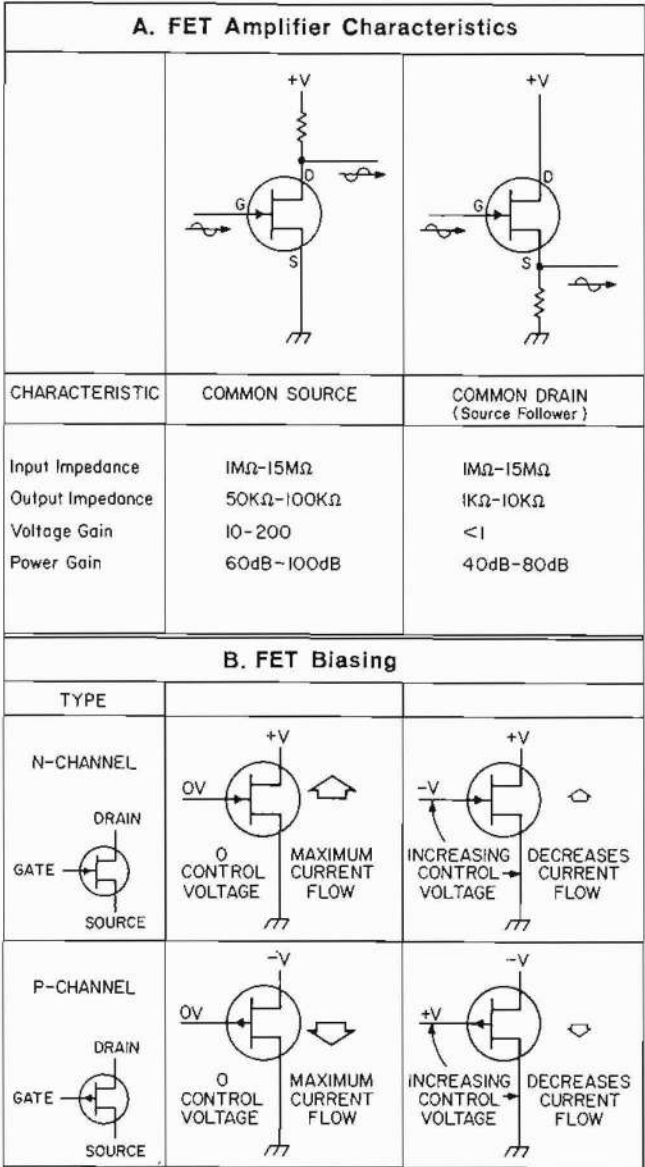

Figure 4-14. Field Effect Transistor Operation

4-31. CLAMPER OR DC RESTORER. The clamper or dc restorer is a circuit which establishes either the positive or negative peak of a waveform at a particular dc reference voltage; in other words, it provides a definite base line voltage for the waveform. Figure 4-15 shows a clamper which provides a base line of about +20 volts for a negative pulse.

4-32. REGULATOR. A diode regulator uses either the constant reverse-bias breakdown voltage characteristic of a breakdown diode or the constant forward-bias voltage drop characteristic of a silicon diode. Power supply reference voltages are generally provided by breakdown diodes which maintain a constant voltage when supplied with a reverse-bias voltage

greater than their specified breakdown voltage. Regulated voltages can also be provided by a forward-biased silicon diode which maintains a constant 0.6 to 0.8 volt drop. Figure 4-15 shows connections for both types of diodes.

4-33. Lead identification for solid state devices varies between various manufacturers. In the interest of providing some correlation between the schematic symbols and the physical device, Figure 4-16, displays some of the typical solid state devices with their lead identifications. In most cases on Hewlett-Packard printed circuit boards, letter designations are silk-screened directly adjacent to the solid state device leads (space permitting) to assist the technician in identifying the solid state device leads. Diode polarity is also identified on the printed circuit boards, but may not be readily visible because of the constraints of component density.

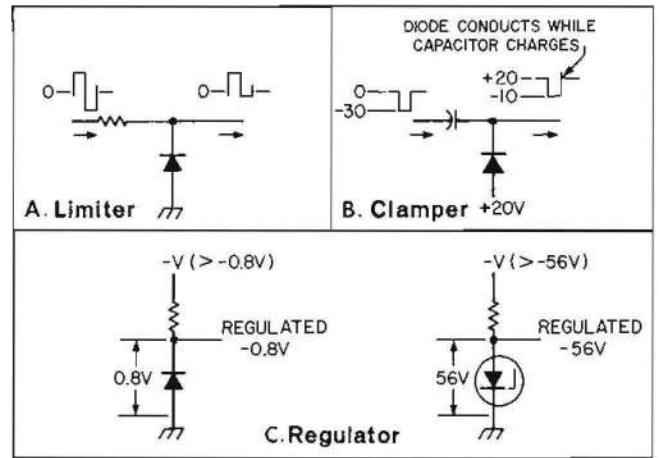

Figure 4-15. Basic Diode Circuits

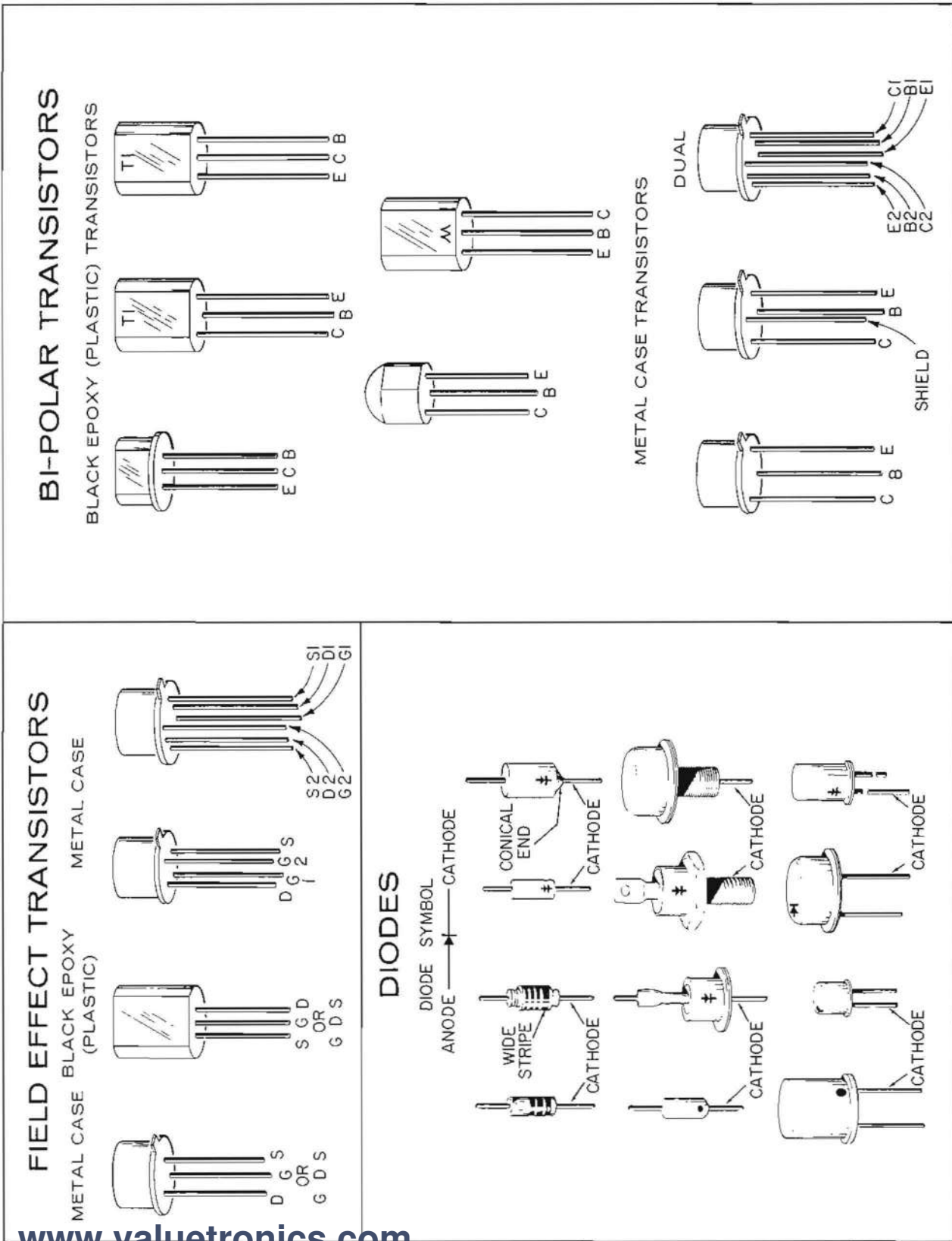

Figure 4-16. Typical Solid State Devices Lead Identification

SECTION V MAINTENANCE

5-1. INTRODUCTION.

5-2. Instructions for performance testing, adjustment, troubleshooting and repairing are contained in this section. The test equipment requirements are tabulated in Table 5-1. Other test equipment equivalent to the suggested test equipment may be used provided that their capabilities are the same or exceed the specifications listed.

5-3. PERFORMANCE TESTING.

5-4. Performance testing of the equipment may be required at incoming receiving inspection, as confidence checking on a scheduled or non-scheduled periodic interval, or as a preamble to internal troubleshooting. A overall performance testing is in general confined to external connections and the observations

of the operations in relation to the Specifications listed in Table 1-1, will give some indications as to whether dismantling and entry into the internal circuit connections is warranted. Five performance tests are possible: an overall performance test, an input sensitivity test, servo output test, a helix output test, and a modulation sensitivity switch check.

5-5. OVERALL PERFORMANCE TEST.

5-6. Connect the 8709A to the test equipment as shown in Figure 5-1. Turn on power to all test equipment and allow the generators and oscillators to stabilize their frequencies (usually two hours or more are required). After the test equipment has stabilized, proceed as follows:

- a. Tune the Signal Generator for a stabilized 20-MHz output signal at a level of approximately -30 dBm.

Table 5-1. Test Equipment Required for Performance Testing and Troubleshooting

Test Instrument	Critical Specifications	Recommended Models
Signal Generator	Frequency Range: 20 MHz Output: Continuously variable between -30 and >-70 dBm	HP 606B
Synchronizer	Capable of stabilizing 20 MHz signal generator	HP 8708A
Oscilloscope and Probe	Frequency Response: 50 MHz Vertical Sensitivity: 5.0 mV Input Impedance with Probe: 10 Meg Ω /10 pf	HP 180A with HP 10001A
Electronic Voltmeter	Accuracy: $\pm 5\%$ Range: $> \pm 20$ Vdc	HP 410C
Ohmmeter function	Open Circuit Voltage: 1.5V max. (on ranges to be used) Short Circuit Current: <3.0 mA (on ranges to be used)	
Clip-On DC Milliammeter	Accuracy: $\pm 5\%$ Range: 1 - 300 mA	HP 428B
VTVM	Reads rms value of sinewave $\pm 2\%$, 20 Hz to 1 MHz	HP 400D
Electronic Counter	Accuracy: ± 1 count \pm time base Range: 0 - 50 MHz	HP 5246L
Battery	1.5 volts	
Capacitor	100 pF	
Resistor	50-ohm 5 watts, 215-ohm 1/2 watt	

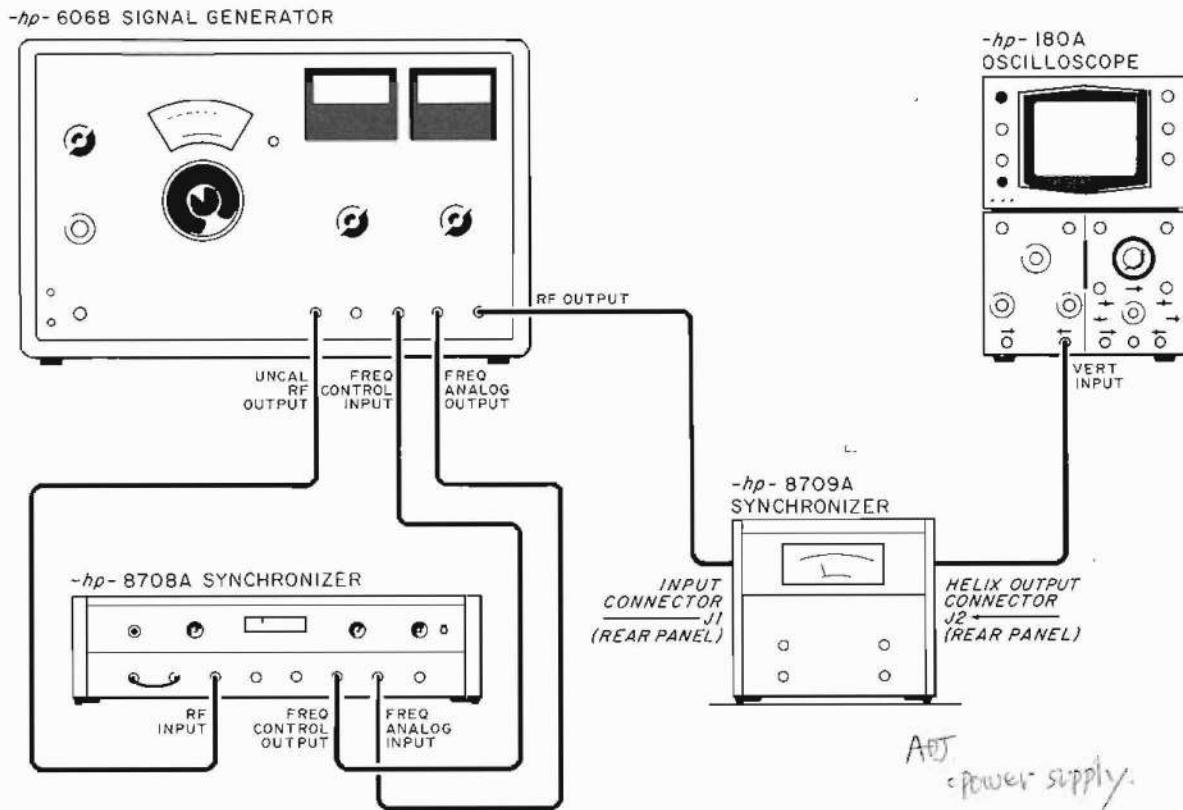

Figure 5-1. Performance Test Setup

b. Observe the oscilloscope display. Fine-tune the 606B for a zero beat with the 8709A internal 20-MHz crystal oscillator. As the phase difference between the signal generator output signal and the synchronizer internal 20-MHz signal drifts through 360 degrees, the oscilloscope display should alternate between a varying dc level and a 500-Hz triangular waveform (search oscillator). The D. C. Portion will vary between +12 volts and -12 volts.

c. Observe synchronizer UNLOCKED indicator and oscilloscope simultaneously. The UNLOCKED indicator should remain lighted as long as the 500 Hz search signal is displayed on the oscilloscope. As soon as the phase-lock varying dc signal appears on the oscilloscope, the UNLOCKED indicator should go out.

NOTE

The beat frequency must be set for less than 1 or 2 Hz to observe the lamp operation.

d. Reduce the output signal level of the signal generator to approximately -65 dBm and observe the oscilloscope display. The UNLOCKED indicator should remain lighted as long as the 500 Hz search signal is displayed on the oscilloscope. The UNLOCKED indicator should go off as in step c.

5-7. INPUT SENSITIVITY TEST.

INPUT SIG -65 dBm 1.5V

5-8. The Input Sensitivity Test requires that the Case top cover and the inside casting cover be removed to gain access to test point A8TP1. Proceed as follows:

a. Disable the 8709A search oscillator by connecting -1.5 volts DC from the 1.5 volt battery cell to A8TP1.

b. Connect the 8709A to the test equipment as shown in Figure 5-2.

c. Adjust the 606B for less than 100 Hz beat frequency at helix output. Beat frequency amplitude should stay constant on the 400D within +1 dB as the 606B output is varied from 0 dBm to -65 dBm. The amplitude should roll off approximately 3 dB with less than -68 dBm output from the 606B.

5-10. (HELIX OUTPUT TEST.)

LOCK UNLOCK 35V ~ 2 15V

5-11. The Helix Output Test requires that the Case top cover and the inside casting cover be removed to gain access to test point A8TP1. Proceed as follows:

a. Disable the 8709A search oscillator by connecting -1.5 volts DC from the 1.5 volt battery cell to A8TP1.

b. Connect the 8709A to the test equipment as shown in Figure 5-3. Do not connect the 215Ω resistor.

c. Adjust the 606B for a 20 MHz input signal of -40 dBm or greater to the 8709A.

d. Tune the 606B for a HELIX OUTPUT beat frequency of less than 100 Hz.

e. Observe the oscilloscope: Amplitude on the oscilloscope should be greater than ±12 volts peak, with respect to zero volts dc reference. (Typical reading should be 15 volts peak; depends on "FREQ RANGE" switch position on 8709 rear).

f. Connect a 215Ω resistor across the HELIX OUTPUT line to ground.

g. Observe the oscilloscope: amplitude on the oscilloscope should be greater than one-half of the open circuit reading of step e (that is the positive and negative peaks of the signal should be more than one-half of the observed peaks of step e).

~~5-12.~~ SERVO OUTPUT TEST.

5-13. Proceed as follows:

a. Connect the 8709A to the test equipment as shown in Figure 5-4.

b. Move "FREQ RANGE" Switch (S3) to the 12.4-40 GHz position.

c. Tune the 606B for a frequency of less than 5 Hertz (dc to 5 Hz).

d. Observe the oscilloscope: amplitude on the oscilloscope should be 2 (±0.4) volts.

e. Disconnect oscilloscope from Servo output.

f. Connect 400D to Servo output.

g. Connect oscilloscope to HELIX output.

h. Set beat frequency to 1 kHz and vary through 100 kHz, while observing 400D meter. Reading of 400D meter should be less than 25 millivolts rms.

5-14. FREQUENCY RANGE SWITCH CHECK.

5-15. The Modulation Sensitivity Switch (S3) is checked in the following manner:

a. Remove case top cover and inside casting cover to gain access to test point A8TP1.

b. Disable the 8709A search oscillator by connecting -1.5 volts DC from the 1.5 volt battery cell to A8TP1.

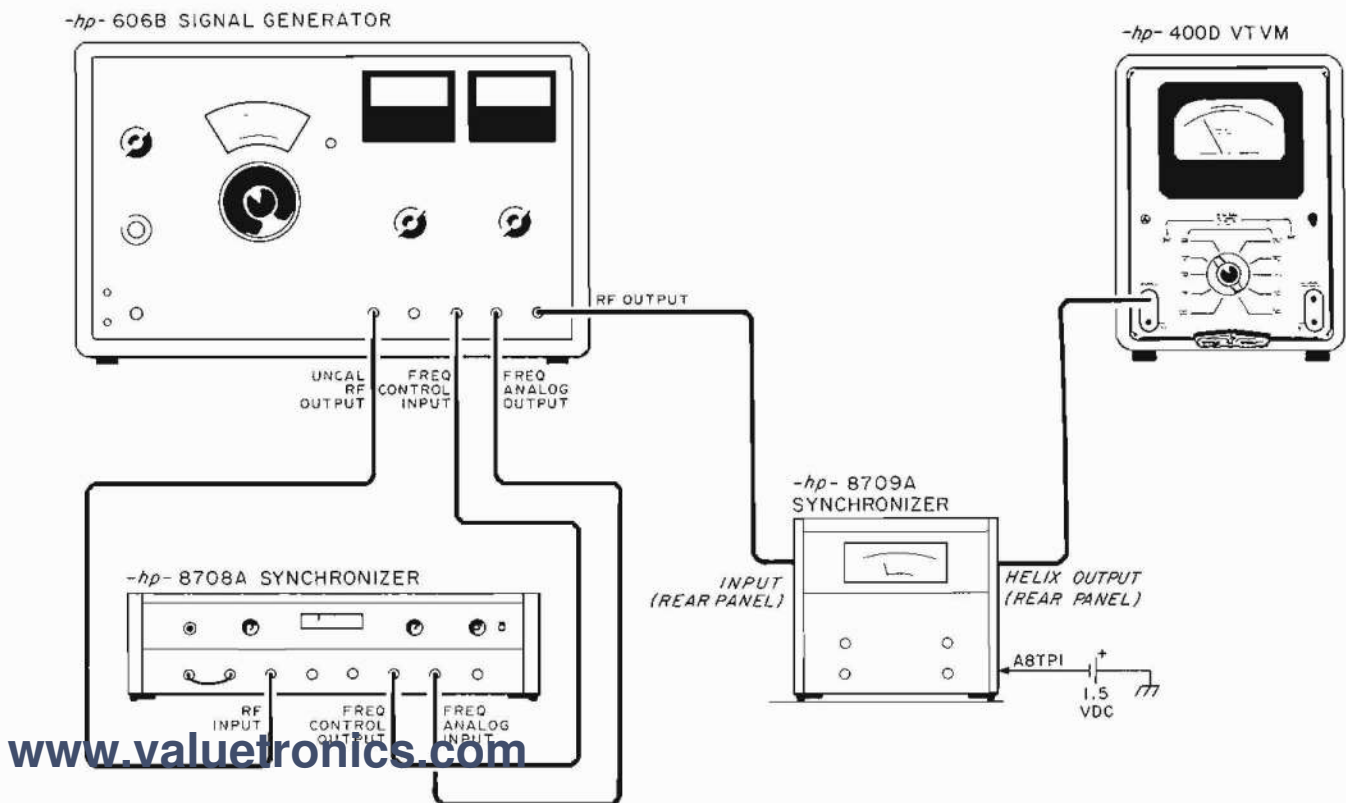

Figure 5-2. Input Sensitivity Test Setup

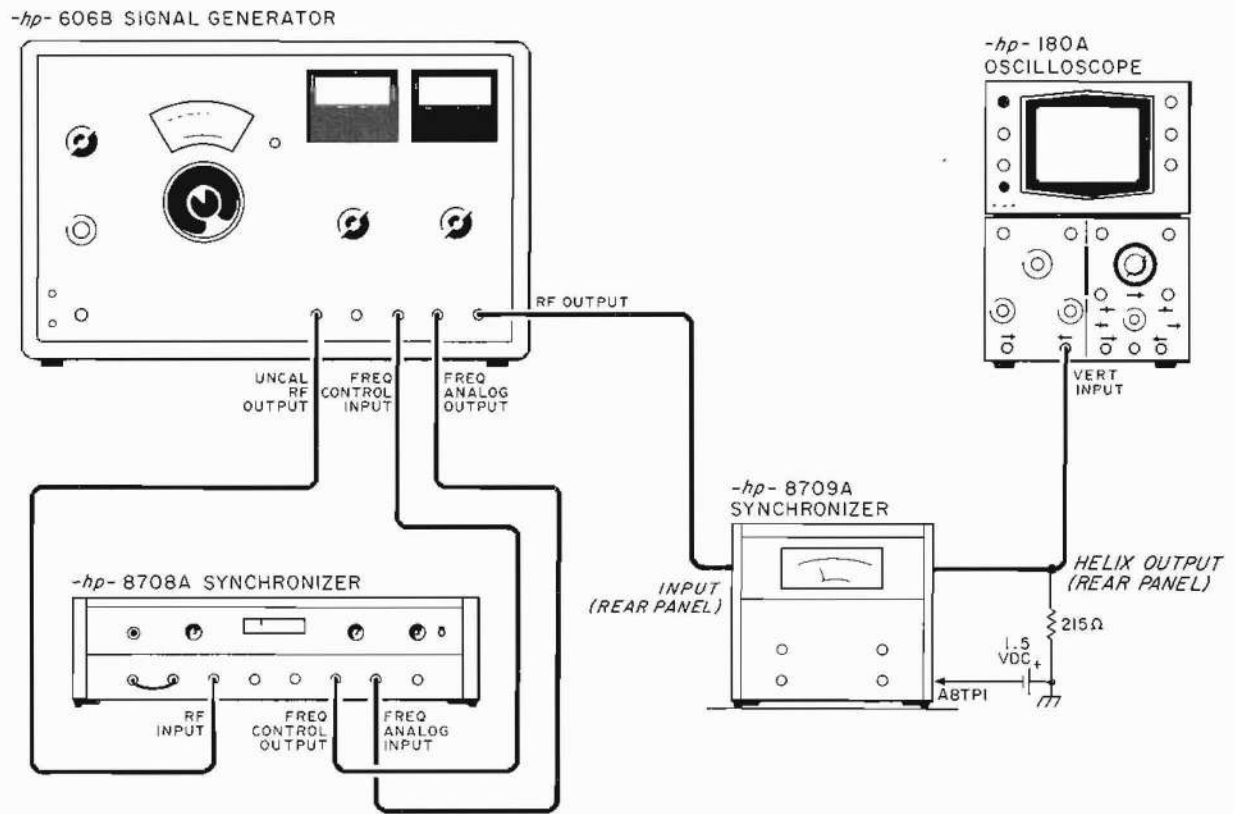

Figure 5-3. Helix Output Test Setup

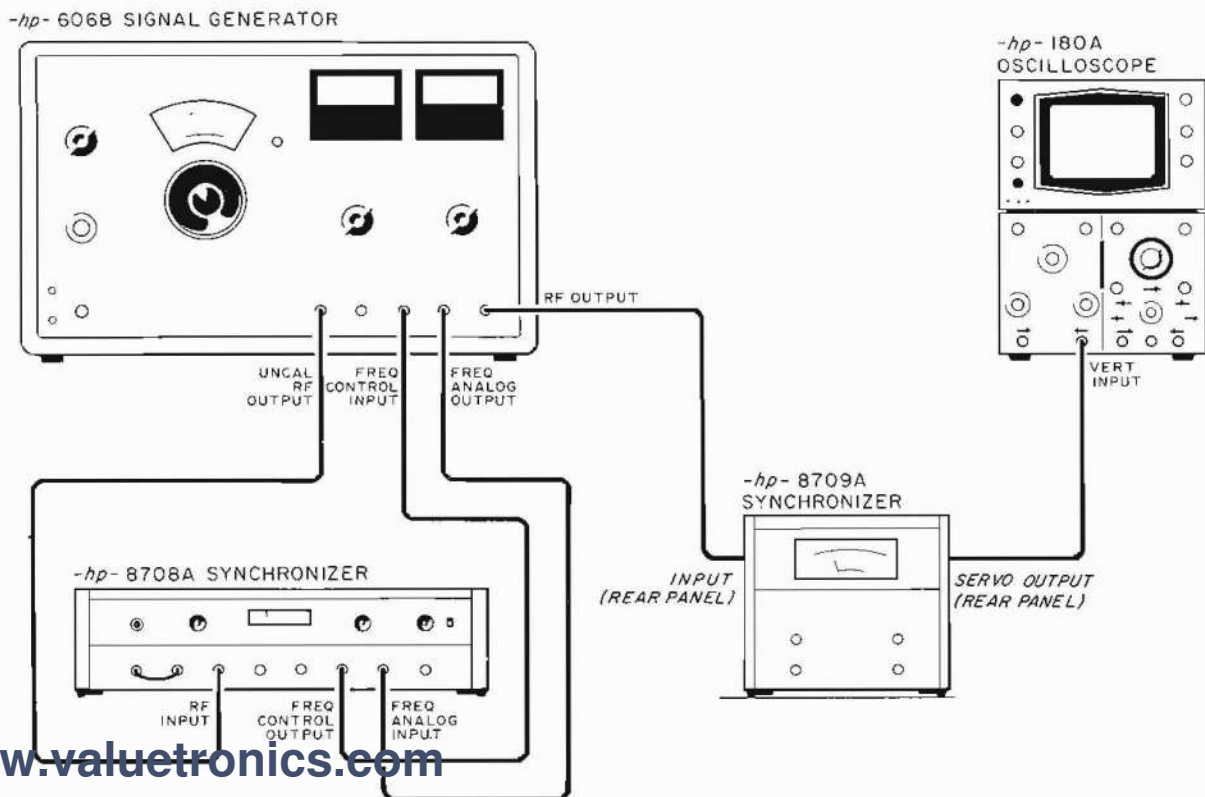

Figure 5-4. Servo Output Test Setup

www.valuetronics.com

c. Connect the 8709A to the test equipment as shown in Figure 5-1.

d. Adjust the 606B for a 100 kHz beat frequency at HELIX OUTPUT as observed on oscilloscope.

e. Adjust the 606B amplitude to -40 dBm.

f. Readings should be:

- (1) 0.5 to 0.85 volt p-p on 1-4 GHz position;
- (2) 0.20 to 0.35 volt p-p on 4-12.4 GHz position
- (3) 0.08 to 0.15 volt p-p on 12.4-40 GHz position

5-16. PREVENTIVE MAINTENANCE.

5-17. Very little preventive maintenance is required for the 8709A Synchronizer. Solid state devices do not usually have the aging effects of vacuum tube designed circuits. Periodic good housekeeping practices of wiping accumulated dust off the surfaces and a clear water rinse wiping of the meter plastic cover is the only preventive maintenance requirements. DO NOT USE SOLVENTS OR ABRASIVES ON THE METER BEZEL.

5-18. TROUBLESHOOTING.

5-19. While making performance tests, observation of any discrepancies will give some indication of the area of faults. Using the Functional Troubleshooting Flow Chart (Figure 5-5), a degree of isolation can be made of the faulty circuits. It is presumed that troubleshooting efforts will be conducted by average electronic technicians having some knowledge of routine electrical measurements and troubleshooting procedures.

5-20. Test equipment listed in Table 5-1 may be used for troubleshooting circuit boards and components in the 8709A.

5-20. CIRCUIT TROUBLESHOOTING.

5-21. After removing the top case cover, measure the voltages at test points A2TP1 through A2TP8. See Figure 7-3 and refer to Table 5-2. Note that there is a variation in the locked and unlocked condition voltage readings.

Table 5-2. Typical A2 Test Point Voltages (vdc)

Test Point	Locked	Unlocked
A2TP1	-1.5	-1.5
A2TP2	-20	-20
A2TP3	+20	+20
A2TP4	+20	+20
A2TP5	-20	-20
A2TP6	+11.0	+8.0
A2TP7	+15.8	+15.8
A2TP8	-17.5	-9.3

5-22. POWER SUPPLY TROUBLESHOOTING.

5-23. Table 5-3 lists the voltages and specifications of the power supply supplied for the 8709A. The power supply is a portion of the A1 Assembly. See Figure 7-5 and Table 5-4.

Table 5-3. Power Supply Specifications

Supply	Voltage	Regulation	Ripple *
+20	20 ± .1 Vdc	102 to 128 V	1 mV rms
-20	20 ± .1 Vdc	102 to 128 V	1 mV rms

*Ripple measured with search oscillator disabled. Disable search oscillator by applying -1.5 Vdc to Test Point A5TP1.

Table 5-4. Typical A1 Test Point DC Voltages

Test Point	Locked	Unlocked
A1TP1	-0.49	-0.39
A1TP2	+20	+20
A1TP3	+13	+13
A1TP4	+34	+34

5-24. Power Supply current limiting is checked as follows:

- a. Connect one end of a 50-ohm, 5-watt resistor to ground; monitor the current on the positive (+) 20 volt supply.

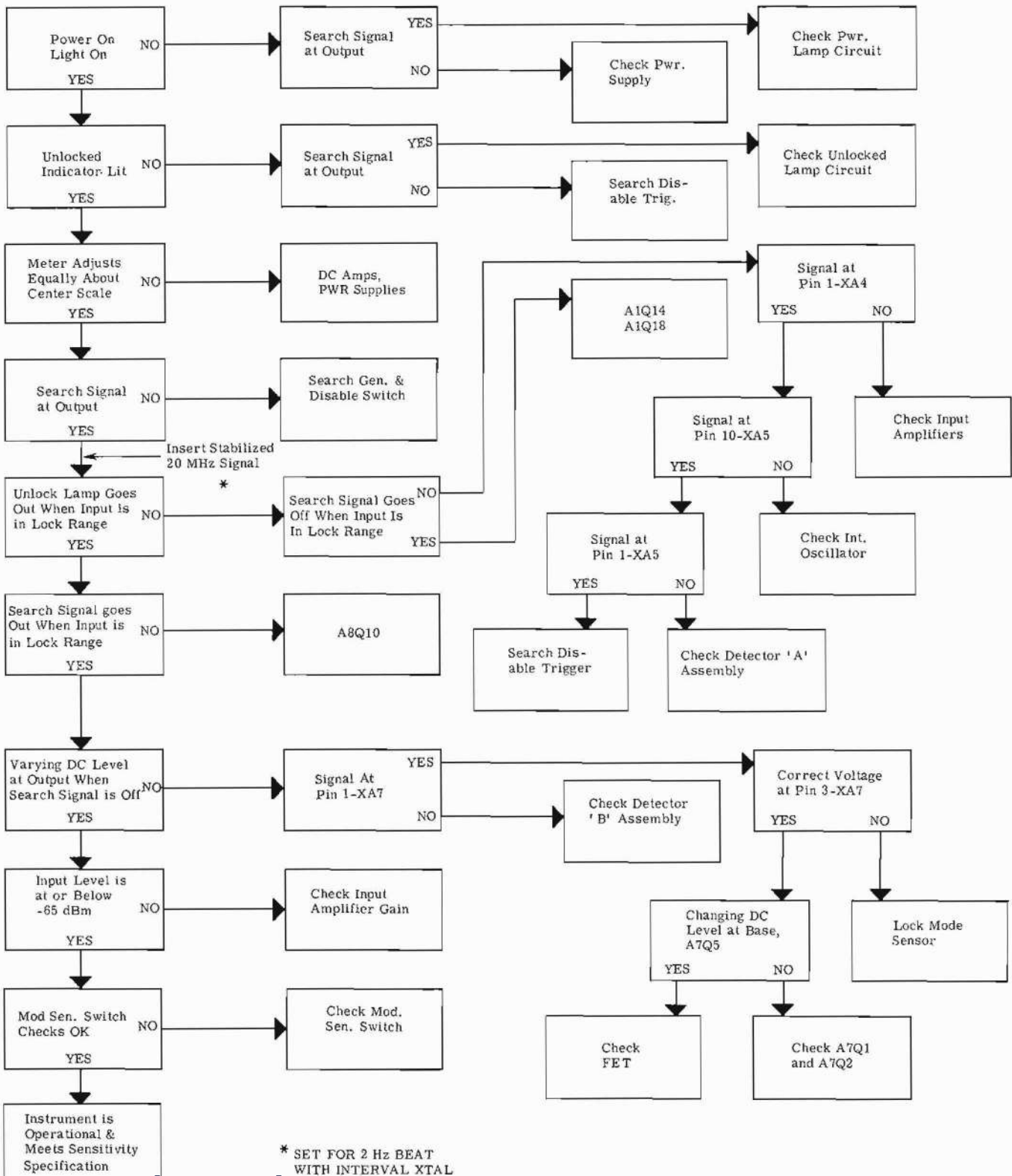

* SET FOR 2 Hz BEAT WITH INTERVAL XTAL

Figure 5-5. Functional Troubleshooting Flow Chart

b. Connect 410C meter to +20 V output.

c. Apply ungrounded end of the 50-ohm resistor to the +20 V output while monitoring the output voltage on the 410C meter voltage should drop indicating current limiting. See Figure 5-6 for graph of typical current limiting.

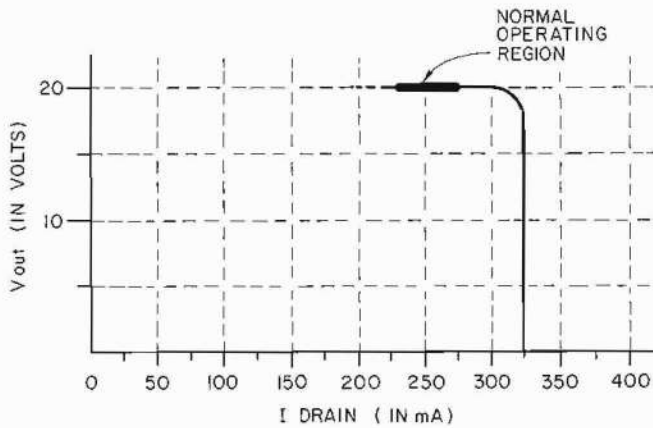

Figure 5-6. Typical Current Limiting Curve

5-25. Use the same procedures of paragraph 5-24 to check the negative (-) 20 volt supply observing polarity change required of metering.

5-26. A quick method of isolating and identifying the circuit board (card) assembly causing overloading of the power supply can be accomplished by monitoring the power supply voltage while removing one assembly at a time. Table 5-5 lists the sequence of assembly removal and the change in power supply drain.

Table 5-5. Assembly Removal Sequence and Effect on Power Supply Current Drain

Assembly Removal	Power Supply Current Drain Should Decrease To:	
	+20 V Supply	-20 V Supply
A8	100 mA	100 mA
A7	95 mA	96 mA
A6	71 mA	82 mA
A5	50 mA	68 mA
A4	60 mA	17 mA

5-27. If a power supply output is incorrect, the voltage throughout the regulation circuit(s) should change to compensate for the variation. A voltage that does not change in the correct direction indicates that the regulator circuit(s) is at fault. If a voltage output is low, check the bridge rectifier output before troubleshooting the regulator circuit(s).

5-28. INPUT AMPLIFIERS A3/A4 TROUBLESHOOTING.

5-29. Check Vcc (at TP2) before troubleshooting the amplifiers. Troubles in the Integrated Circuit (IC) amplifiers are easily located by injecting a 20-MHz signal into INPUT jack J1 and tracing the signals through the amplifier assemblies using a high impedance scope probe (10 meg/10pf) and 50 MHz slope. Each IC amplifier should have approximately 20 dB gain. When measuring the gain of an IC amplifier adjust the input level to ensure that the output is not being limited. Test Point Values for assemblies A3 and A4 are in Table 5-6.

Table 5-6. Typical A3 and A4 Test Point DC Voltages

Test Point	Locked	Unlocked
A3TP1	0	0
A3TP2	+8.4	+8.4
A3TP3	+7.2	+7.2
A4TP1	0	0
A4TP2	+12.3	+12.3
A4TP3	+7	+7
A4TP4	8.8	8.8
A4TP5	7.6	7.6

5-30. PHASE DETECTORS TROUBLESHOOTING.

5-31. The phase detectors are mounted on assembly A5. Check the +20 V and -20 V inputs before troubleshooting the phase detectors. Check the waveforms at the four corners of the bridge detector to determine what part of the phase detector assembly is faulty. A signal of correct amplitude at the output of the phase shifter (A5TP6) test point indicates that phase shifter "B" is functioning properly. DC voltages at the test points are in Table 5-7.

5-32. 20-MHz OSCILLATOR ASSEMBLY TROUBLESHOOTING.

5-33. The 20-MHz Oscillator assembly is mounted on Card A6. Check the +20 V and -20 V inputs before troubleshooting the oscillator assembly. Check waveform at the output of the oscillator at test point A6TP1

Table 5-7. Typical A5 Test Point DC Voltages

Test Point	Locked	Unlocked
A5TP1	-0.44	-0.055
A5TP2	-0.002	-0.003
A5TP3	-0.17	-0.36
A5TP4	+9.4	+9.9
A5TP5	+10.5	+11
A5TP6	+0.0046	-

to determine whether the trouble is in the oscillator or in the amplifier section. With no signal in the 8709A INPUT, measure the crystal oscillator frequency with a 5245L Counter (or equivalent) through a 100 pF series capacitor connected to A5TP4. Frequency should be $20 \text{ MHz} \pm 1.0 \text{ kHz}$.

NOTE

The measurement of crystal oscillator frequency must be made on the following stage board A5 to reduce loading of the oscillator and resulting frequency shift. Typical dc voltages for A6TP1 is +9.3 volts dc; for A6TP2, -1.66 volts dc.

5-34. TROUBLESHOOTING THE LOCK-MODE SENSOR AND SEARCH DISABLE TRIGGER.

5-35. The Lock-Mode Sensor and Search Disable Trigger are part of the A8 Card Assembly. Check the +20 and -20 V inputs before troubleshooting the lock-mode sensor and search disable trigger. Check for correct input level at TP1. Test Point values for assembly A8 is in Table 5-8. Shorting alternate emitter-base junctions and observing the collector voltage of the opposite transistor will indicate which half of the circuit is faulty.

Table 5-8. Typical A8 Test Point DC Voltages

Test Point	Locked	Unlocked
A8TP1	-0.4	+0.054
A8TP2	+9.2	+11
A8TP3	+0.79	+0.57
A8TP4	-0.03	+0.62
A8TP5	-17.5	-9.4

5-36. TROUBLESHOOTING THE SEARCH SIGNAL GENERATOR AND SEARCH DISABLE SWITCH.

5-37. The Search Signal Generator and Search Disable Switch circuits are part of the A8 Card Assembly. See Table 5-8 for typical Test Point values. Check the +20 and -20 V inputs before troubleshooting the search signal generator. The signal at the search generator output (A8TP3) determines whether the search generator, the search disable switch, or the output coupling is defective. A zero or very small dc level usually indicates that search disable switch A8Q10 is at fault. A positive or negative dc level indicates that the trouble is in the search generator. Measuring the voltage at A8TP4 will further determine which part of the search generator is defective. For example, if the output is a positive dc level, a high negative voltage at A8TP4 indicates that the Schmitt Trigger is in the proper state and the trouble is in Current Generators A8Q6 and A8Q7; a low negative or positive voltage at A8TP4 indicates that the Schmitt Trigger is not in the proper state and the trouble is in the Schmitt Trigger, A8Q4 and A8Q5, or Emitter Follower A8Q3.

5-38. To check the search oscillator and search disable switch at the Output Jack J2, proceed as follows:

- Make sure that the front panel meter is on zero.
- Connect the equipment as shown in Figure 5-1. Frequency on the oscilloscope display should be $500 \text{ Hz} \pm 100 \text{ Hz}$. Amplitude should be 10 to 15 volts p-p for the 1-4 GHz position of the MODULATION SENSITIVITY switch and 7 volts ± 2 volts p-p for the 4-12.4 GHz and 12.4-40.0 GHz position. Check shut-off of search oscillator by applying a -1.5 volts to A8TP1. This should disable the search oscillator.

5-39. DC AMPLIFIERS TROUBLESHOOTING.

5-40. Check the +20 and -20 V inputs before troubleshooting the dc amplifiers. The dc amplifiers are part of the A7 Card Assembly. Limited meter range indicates a malfunction between the METER ADJUST potentiometer and the Phase Error meter. Decreased adjustment range indicates reduced gain in one of the stages. To locate the defective stage, measure the voltage swing at stage outputs while varying the Meter Adjust Potentiometer through its range. Test Point values for assembly A7 are in Table 5-9.

5-41. Inability to adjust the meter to zero indicates that a malfunction has caused one of the stages to be biased heavily in one direction (such as power supply voltages much off of $\pm 20 \text{ V}$). To locate the defective stage, measure the locked and/or unlocked voltages and compare to values shown on the schematics.

5-42. LIGHT AMPLIFIER TROUBLESHOOTING.

5-43. The indicator lamp (DS2) should be checked for filament continuity before other troubleshooting if the

Table 5-9. Typical A7 Test Point DC Voltages

Test Point	Locked	Unlocked
A7TP1	-0.035	-0.027
A7TP2	+0.065	+2.85
A7TP3	-0.43	-0.05
A7TP4	-0.38	-0.36
A7TP5	+11	+8.2
A7TP6	+11	+8.2

lamp fails to light. If the lamp continuity is normal, the light amplifier can be checked by applying a ground to test point A8TP5; grounding A8TP5 should make the light amplifier conduct so that the unlocked indicator is lighted. If this procedure does not make the indicator light, measure the emitter-to-base voltage drop on A1Q11 and A1Q12 transistors. The voltage should be approximately 0.7 volts when the transistors are turned on.

5-44. ISOLATING TRANSISTOR MALFUNCTIONS.

5-45. A brief review of solid state device circuit function is contained in Section IV. In addition to the locked and unlocked typical voltage values listed on the schematics, Table 5-10 tabulates the same information for all transistors contained within the 8709A. Exact values for transistors operating under conditions of saturation and cut-off are not possible since transistor manufacturing tolerances are not specific and will vary between transistors of the same series. In addition, the point or degree of phase-lock will shift during "locked" conditions so that dc voltage readings may or may not be repeatable. The ratio of locked to unlocked voltage readings and the saturated versus cutoff ratio is the guideline to be used when viewing the voltage readings both on the base-emitter-collector voltage table (5-10) and on the schematics.

5-46. IN-CIRCUIT TRANSISTOR TESTING.

5-47. When checking a suspected transistor stage in the circuit, determine if the base junction is forward-biased:

CAUTION

Do not place the leads of an electronic voltmeter directly across the emitter-base junction to measure voltage difference. Loop current may be excessive between the voltmeter leads and may damage the transistor. Measure each voltage separately with respect to a common point such

www.valuetronics.com

If the junction is not forward-biased, and power supply voltages are known to be correct, the base-emitter junction may be open.

5-48. When the emitter-base junction is forward-biased, check for amplification by short-circuiting the base to the emitter while observing collector voltage. The short-circuiting eliminates the base/emitter bias and should cause the transistor to stop conducting, and the collector voltage should shift toward the supply voltage value. Any voltage difference (less than the supply voltage) is due to leakage current through the transistor; in general, the smaller the leakage current, the better the transistor. If collector voltage does not change, the transistor has either an emitter-collector short-circuit, or emitter-base open circuit.

5-49. OUT-OF-CIRCUIT TRANSISTOR TESTING WITH OHMMETER.

5-50. If a short or open circuit is suspected, the transistor can be removed from the assembly and the internal resistance between junctions measured with an ohmmeter. Table 5-11 lists typical resistance values for transistors.

CAUTION

Do not measure the junction resistance of a transistor with an ohmmeter having an unknown value of voltage/current. Some ohmmeters can damage a transistor. Before using for transistor measurements, the ohmmeter should be checked on the resistance range to be used. Open-circuit voltage should not be over 1.5 volts and short-circuit current should be less than 3-milliamperes. Table 5-12 lists some ohmmeters with their safe resistance ranges.

5-51. REPAIR AND REPLACEMENT.

5-52. The majority of components on the card assemblies as well as cabinet mounted parts can be replaced. Section VI in this instruction manual lists the replaceable parts available from Hewlett-Packard. Substitution of component parts such as resistors and capacitors having identical physical and electrical characteristics and specifications may be accomplished in the field, however, certain matched components and factory preselected and/or factory trimmed components should not be attempted.

5-53. ETCHED CIRCUIT BOARD REPAIR.

5-54. The etched circuit boards in the 8709A are of the plated-through type, joining the metallic conductor paths on both sides of the insulating board material. The metallic conductors extend through the component mounting holes by a plating process. Soldering can be accomplished from either side of the board with equally good results. Table 5-13 lists some of the recommended soldering tools and materials used for etched circuit board work. Recommendations and precautions for etched circuit repair work are as follows:

Table 5-10. 8709A Transistor Base-Emitter-Collector Typical Voltages

	A1 L	A1 UL	A4 L	A4 UL	A5 L	A5 UL	A6 L	A6 UL	A7 L	A7 UL	A8 L	A8 UL
Q1 b	-0.52	na	+7.5	+7.5	-0.28	-0.034	nr	+1.7	+0.066	+6.4	-0.15	+0.05
e	Grnd	na	+6.8	+6.8	-0.96	-0.65		+0.98	-0.12	+6.2	-0.25	-0.26
c	-13	na	+11.4	+11.4	+17.3	+17.3		+5.7	+20	+20	+4.3	+2.9
Q2 b	-9.9	na	+12.5	+12.5	-0.24	+0.062	nr	0.0	-0.2	+0.67	+4.1	+2.75
e	-10.5	na	+12.3	+12.3	-0.94	-0.54		-0.75	0.0	0.0	+3.5	+2.2
c	-1.1	na	+12.6	+12.6	+17.3	+17.3		+5.8	-0.42	+0.006	+9.1	+12.7
Q3 b	-1.1	na		Q3 b	-9.4	-9.4	nr	+5.8	+9.1	+12.6	+10.5	+10.5
e	-0.53	na		e	-10	-10		+6.5	+9.7	+13.0	+10.5	+11.0
c	-13	na		c	0.0	0.0		-0.11	+1.85	-5.0	0.0	0.0
Q4 b	-13.5	na		Q4 b	-0.32	-0.32		Q4 b	G+0.26	G-5.0	+11.6	+11.3
e	-14	na		e	-0.71	-0.71		e	D-0.28	D-0.064	+12.5	+11.5
c	-10	na		c	+10.6	+10.6		c	S-0.3	S+0.007	+12.4	+8.6
Q5 b	-13	na		Q5 b	-0.008	-0.008		Q5 b	-0.41	-0.45	+12.5	+8.9
e	-13.5	na		e	-0.52	+0.052		e	-1.05	-0.88	+12.4	+9.2
c	-0.8	na		c	+9.4	+9.4		c	+11.5	+18.5	-0.031	+0.014
Q6 b	+6.8	na		Q6 b	-7.9	-7.9		Q6 b	-0.41	+0.0064	-9.7	-9.7
e	+6.2	na		e	-8.7	-8.7		e	-10.0	-0.6	-10.4	-10.4
c	+20.8	na		c	-1.7	-1.7		c	+10.0	+7.3	+0.78	+0.67
Q7 b	+20.5	na						Q7 b	-0.002	-0.002	+10.0	+10.0
e	+20	na						e	-0.6	-0.58	+10.7	+10.7
c	+32	na						c	+10.6	+7.4	+0.72	+14.0
Q8 b	+21.0	na		A1 (continued)				Q8 b	+10.6	+7.4	-0.42	+0.05
e	+20.5	na		A1 L	A1 UL			e	+10.1	+6.7	+0.29	+0.57
c	+32	na						c	+18.3	+18.5	-0.055	-2.4
Q9 b	+29.5	na		Q14b	+10.1	+7.7			Q9 b	+0.08	-2.25	
e	+30.2	na		e	+10.1	+8.0			e	+0.9	-1.67	
c	+21.0	na		c	-20.0	-20.0			c	-17.5	-8.3	
Q10b	+33	na		Q15b	+4.2	-15.5			Q10b	-0.7	+1.75	
e	+34.0	na		e	-2.0	-14.7			e	0.0	0.0	
c	+29.5	na		c	-20.0	-20.0			c	-0.032	+0.007	
Q11b	-18.3	-8.8		Q16b	+5.8	-13.2						
e	-19	-9.5		e	+5	-13.8						
c	-0.021	-2.3		c	+20	+20						
Q12b	-17.7	-8.2		Q17b	-17.5	-15						
e	-18.3	-8.8		e	-18	-15.5						
c	Grnd	Grnd		c	+4.2	-15.5						
Q13b	+10	+7.4										
e	+10.1	+8.0										
c	-17	-14.8										

L = Locked (phase)
 UL = Unlocked
 nr = not readable
 G = Gate
 D = Drain
 S = Source

Table 5-11. Typical Transistor Resistance Values

Transistor Type		Connect Ohmmeter		Measure Resistance (ohms)
		Pos. lead to	Neg. lead to	
PNP Germanium	Small Signal	emitter	base*	200 - 500
		emitter	collector	10K - 100K
	Power	emitter	base*	30 - 50
		emitter	collector	several hundred
NPN Silicon	Small Signal	base	emitter	1K - 3K
		collector	emitter	very high (might read open)
	Power	base	emitter	200 - 1000
		collector	emitter	high, often greater than 1 M

Measurements made on transistors removed from circuit.
*To check collector, short collector to base; resistance should decrease.

a. Component substitution should be avoided. Lead diameters and physical dimensions have been matched to the circuit board solder pad spacing and hole diameters. Damage to the circuit board and/or adjacent components may result if substitute components are installed.

b. Do not use a high wattage soldering iron on etched circuit boards. Excessive heat applied to the solder pads and paths may lift the conductor paths. Tip size should be as small as possible consistent with the work. Large tips may heat damage adjacent components.

c. Use a suction device (such as listed in Table 5-13) or a wooden toothpick to clear solder from component mounting holes.

CAUTION

Do not use a sharp metal tool (such as an awl or twist drill) to clear solder from solder pad component mounting hole. Hard or sharp metal devices may damage the plated-through conducting path.

www.valuetronics.com

d. After soldering, remove excessive flux from the circuit board with a suitable flux solvent and apply a protective coating to the soldered joint to prevent/reduce contamination and future corrosion.

5-55. A broken or burned section of conductor path can be repaired by bridging the damaged section with a length of tinned copper wire. Remove protective varnish coating from the circuit paths to be joined; with a very sharp blade (such as a razor blade or X-acto knife. Cut through and trim the ends of the conductor but not through to damage the circuit board; carefully lift the damaged circuit path from the surface and discard. Cut the bridging wire line enough to overlap the circuit paths; pre-tin the wire ends and the solder path ends; quickly join the wire and solder path by reflow soldering (the wire does not have to lie flat against the insulating board); clean off excess flux and coat new path and solder joints with protective coating.

5-56. COMPONENT REPLACEMENT.

5-57. To replace a defective component, proceed as follows:

a. If axial lead component such as resistors or capacitors: clip off component by cutting lead(s) near

Table 5-12. Safe Ohmmeter Ranges for Transistor Resistance Measurements

Ohm-meter	Safe Range(s)	Open Ckt Voltage	Short Ckt Current	Color	Polarity
HP 412A	R x 1K	1.0 V	1 mA	Red Black	+ -
	R x 10K	1.0 V	100 μ A		
	R x 100K	1.0 V	10 μ A		
	R x 1M	1.0 V	1 μ A		
	R x 10M	1.0 V	0.1 μ A		
HP 410C	R x 1K	1.3 V	0.57mA	Red Black	+ -
	R x 10K	1.3 V	57 μ A		
	R x 100K	1.3 V	5.7 μ A		
	R x 1M	1.3 V	0.5 μ A		
	R x 10M	1.3 V	0.05 μ A		
HP 410B	R x 100	1.1 V	1.1 mA	Black Red	+ -
	R x 1K	1.1 V	110 μ A		
	R x 10K	1.1 V	11 μ A		
	R x 100K	1.1 V	1.1 μ A		
	R x 1M	1.1 V	0.11 μ A		
Simpson 260	R x 100	1.5 V	1 mA	Red Black	+ -
Simpson 260	R x 1K	1.5 V	0.82mA	Black Red	+ -
Triplet 630	R x 100	1.5 V	3.25mA	Varies with Serial Number	
	R x 1K	1.5 V	325 μ A		
Triplet 310	R x 10	1.5 V	750 μ A		
	R x 100	1.5 V	75 μ A		

Table 5-13. Etched Circuit Soldering Equipment

Item	Use	Specification	Item Recommended
Soldering Tool	Soldering Unsoldering	Wattage rating: 47-1/2 - 56-1/2 Tip Temp: 850 - 900°	Ungar #776 Handle with *Ungar #4037 Heating Unit
Soldering *Tip	Soldering Unsoldering	*Shape: pointed	*Ungar #PL111
De-soldering Aid	To remove molten solder from connection	Suction device	Soldapullt by Edsyn Co. Arleta, California
Resin (flux) Solvent	Remove excess flux from soldered area before application of protective coating	Must not dissolve etched circuit base board material or conductor bonding agent	Freon
			Acetone
			Lacquer Thinner
			Isopropyl Alcohol (100% dry)
Solder	Component replacement Circuit board repair Wiring	Resin (Flux) core, high tin content (60/40 tin/lead), 18 gauge (SWG) preferred	
Protective Coating	Contamination, corrosion protection	Good electrical insulation, corrosion-prevention properties	Krylon® ** #1302
			Humiseal Protective Coating, Type 1B12 by Columbia Technical Corp., Woodside 77, New York
*For working on 852 Boards: for general purpose work, use Ungar #1237 Heating Unit (37.5W, tip temp of 750-800°) and Ungar #PL113 1/8" chisel tip.			
**Krylon, Inc., Norristown, Pennsylvania.			

body of the component; discard defective component; straighten leads remaining in board so that they are vertical to board; wrap leads of replacement component (one turn) around the original leads; solder the lead-to-lead wrapped connection; clip off excess leads.

b. If component must be removed from board, apply heat to soldering pad(s); as soon as solder is molten, lift component lead out of solder pad mounting hole:

CAUTION

Do not apply tension to component lead until solder is molten (liquid). Pulling on the component lead before the solder is melted may lift the solder pad from the board and may additionally ruin the attached circuit path.

WARNING

Do not apply tension to component lead while heating solder pad. Even if the board is not damaged by this practice, the possibility of solder being flicked towards the direction of component lead pull may splash hot solder into the eyes. Hot solder splashed on the eye may cause permanent or temporary blindness.

After the component has been removed from the circuit board, reheat the solder pad. Use a solder-sipper or wooden toothpick to remove the solder from the solder-pad mounting hole(s). Form the pads of the replacement component to match the spacing of the solder-pad spacing; carefully insert the leads of the replacement component through the cleaned out solder-pad mounting holes: DO NOT FORCE THE LEAD THROUGH THE HOLES. If the leads do not pass easily through, either

the solder has not been cleared or the new component leads are too large. Forcing oversize leads through solder-pad mounting holes will damage the plated through conductor path and may produce circuit failures. The choice of (a) soldering before clipping the excess lead or (b) bending the lead to follow the circuit path on the opposite side of the board, clipping, and forming before soldering, is at the discretion of the repairman.

5-58. TRANSISTOR REPLACEMENT.

5-59. If a transistor is known to be defective, remove the transistor in the same manner as for any component, however, if a transistor is to be removed for purpose of out-of-circuit resistance measurements, use the following procedure:

a. Place a heat-sink on the transistor lead before applying heat to the solder-pad/lead junction. (If a specific heat-sink is not available or too large to insert between the transistor case and board, gripping the transistor lead firmly with the flats of long-nose pliers will be effective as a heat-sink.). Heat the solder-pad/lead junction and lift the lead out of the mounting hole when the solder is molten. Shift the heat-sink (pliers) to the next transistor lead and heat and lift lead, etc. until all transistor leads are free. Reheat solder-pad and clear solder from mounting hole with solder-sipper or wooden toothpick.

b. Clean transistor leads by heating the lead held by heat-sink or pliers and gently shaking off the excess molten solder.

5-60. When installing either an old or replacement transistor, a plier heat-sink must be used to prevent damage to the transistor. When installing a replacement transistor, cut the leads of the new transistor to exactly the same length as the old (faulty or damaged) transistor: Lead length must serve two purposes: (1) sufficient length for heat-sinking between the transistor case and the solder-pad/lead junction, (2) excessively long leads may change circuit operation because of lead-inductance and/or capacitance change. Transistor lead length is especially critical in high frequency and microwave frequency applications. To install a transistor:

a. Insert all leads (if possible) into the solder-pad mounting holes.

b. Grasp the transistor lead with a heat-sink between the transistor case and the solder-pad/lead junction before applying heat to the junction from the opposite side of the board. Reflow soldering is easily accomplished by the amount of solder normally on the circuit-path/solder-pad. Remove heat, but do not remove heat-sink. Move heat-sink to next transistor lead and repeat the soldering operation etc. When installing transistors, the practice should be heat-sink on first and removed last.

5-61. DIODE REPLACEMENT.

5-62. Removal and replacement of diodes combine the best practices of component replacement and transistor replacement. If the diode is known to be defective, it can be handled like any axial lead component when removing from the circuit board. But if the diode is to be tested out-of-circuit, then heat-sinking of the diode lead (between the diode body and the diode-lead/solder-pad junction) before applying heat to the solder-pad is necessary.

5-63. Solid-state diodes are packaged in many physical forms; such proliferation and variance may cause confusion in regard to which lead or connection is the negative cathode or the positive anode. Standardization of identification is not industry wide. Figure 4-16 in the Section IV gives some identification of diode polarity marking. However, if identification is not legible or confused, ohmmeter measurement can be used to determine the diode polarity.

NOTE

It is necessary to know the polarity of the OHMS lead with respect to the common or GROUND lead to determine diode polarity with an ohmmeter. For example: on the HP Model 410B Vacuum Tube Voltmeter, the OHMS lead is negative (-) in respect to the COMMON lead, whereas, on the HP Model 412A DC Vacuum Tube Voltmeter, the OHMS lead is positive (+) in respect to the COMMON lead.

5-64. Replacement installation of diodes requires the use of heat sinking between the lead/solder-pad junction and the diode body before applying heat for reflow soldering on the opposite side of the board. If axial lead component replacement practice is used, heat sink must be installed before heating the lead-to-lead wrap.

5-65. SPECIAL REPAIR AND REPLACEMENT INFORMATION.

5-66. Circuit board assembly A5 (Phase Detector Assembly) has been modified for the 8709A circuit. Diodes CR5, 6, 7, and 8 are NOT to be installed according to the polarity markings silkscreened on the circuit board. Special instructions will be forwarded upon request to the Hewlett-Packard Spectroscopy Sales Office, Palo Alto, California.

5-67. Resistor R2 (75Ω 1% 1/8-watt) listed on the schematic and in Section VI for circuit board assembly A8 (Search Generator Assembly) is a Factory Selected Value Only and the listing is a nominal value. If replacement of A8 R2 is required, special instructions will be forwarded if extremely necessary. However, selection and circuit trimming of this assembly is normally a HP factory-return repair item.

5-68. ADJUSTMENTS.

5-69. Only three adjustments are provided in the 8709A. After repair/replacement of components, PHASE ERROR meter adjustment and/or Search Oscillator Filter in the servo output adjustment may be required. Normally, there should be no need for making adjustments to the 8709A.

5-70. If the 20-MHz quartz crystal on circuit board assembly A6 (20-MHz Oscillator Assembly) is ever replaced, it may be necessary to return coil A6L2 to set the oscillator frequency to 20 MHz (+1 kHz) but otherwise the factory seal should not be disturbed. Adjustment of A6L2 should ONLY be made with calibrated laboratory equipment and the coil core should be re-sealed after adjustment. The frequency is measured as described in paragraph 5-31.

ASTPA

5-71. PHASE ERROR METER ADJUSTMENT.

5-72. The following operation is required to adjust the PHASE ERROR meter:

a. Connect the 8709A to the test equipment as shown in Figure 5-1. Turn on power to all test equipment and allow the generators and oscillators to stabilize their frequencies (usually two hours or more are required). After the test equipment has stabilized, proceed as follows:

b. Adjust the 606B for 20-MHz ± 0.1 -MHz at -40 dBm, until a frequency difference of 100-kHz or less exists between the input signal and the 8709A internal 20-MHz oscillator.

c. Observe the oscilloscope. Signal should appear as a distortion of the triangular waveform.

d. Adjust the METER ADJUST control (front panel screwdriver drive) so that the PHASE ERROR meter indicator needle is centered.

e. Check the range of the METER ADJUST control. Meter needle should be adjustable at least the length

of the arrows on the meter face in both directions from zero. Set adjustable resistor R10 on Assembly A7 so that meter needle control by the METER ADJUST control is approximately symmetrical around the meter center position.

f. Adjust the METER ADJUST control so that the PHASE ERROR meter indicator needle is centered.

5-74. ADJUSTMENT OF THE SEARCH OSCILLATOR FILTER.

5-74. The following is required to adjust the search oscillator filter in the Servo Output:

a. Set the Modulation Sensitivity Switch (S3 on rear panel) to 1-4 GHz position.

b. Check that no signal is connected to INPUT jack J1 (turn on power to 8709A if not previously on).

c. Connect a Model 400D VTVM to the SERVO OUTPUT jack on the 8709A rear panel.

d. While observing the 400D meter, adjust resistor R37 on Assembly A1 for a minimum search oscillator signal. Meter reading should be less than 10-millivolts rms.

5-75. PROCEDURES AFTER REPAIR AND MAINTENANCE.

5-76. After repairs and/or replacement activities, it is recommended that performance tests be run again before replacing the covers and screws. Performance tests are in the front of this section (V).

5-77. After post-maintenance performance tests have been run, replace the inside casting cover after checking that all circuit boards are firmly seated in their chassis connectors. Replace outside case covers if used.

SECTION VI REPLACEABLE PARTS

6-1. INTRODUCTION.

6-2. This section contains information for ordering replacement parts. Table 6-1 lists parts in alpha-numerical order of their reference designators and indicates the description and HP stock number of each part, together with any applicable notes. Miscellaneous parts are listed at the end of Table 6-1. Table 6-2 lists parts in alpha-numerical order of their HP stock number and provides the following information on each part:

- a. Description.
- b. Manufacturer of the part in a five-digit code; see list of manufacturers in Table 6-3.
- c. Manufacturer's part number.
- d. Total quantity used (TQ column).

6-3. ORDERING INFORMATION.

6-4. To obtain replacement parts, address order or inquiry to your local Hewlett-Packard Field Office (see list at rear of this manual for addresses). Identify parts by their Hewlett-Packard stock numbers.

6-5. To obtain a part that is not listed, include:

- a. Instrument model number.
- b. Instrument serial number.
- c. Description of the part.
- d. Function and location of the part.

REFERENCE DESIGNATORS

A = assembly	F = fuse	MP = mechanical part	V = vacuum, tube, neon bulb, photocell, etc.
B = motor	FL = filter	P = plug	VR = voltage regulator
BT = battery	IC = integrated circuit	Q = transistor	W = cable
C = capacitor	J = jack	R = resistor	X = socket
CP = coupler	K = relay	RT = thermistor	Y = crystal
CR = diode	L = inductor	S = switch	Z = tuned cavity, network
DL = delay line	LS = loud speaker	T = transformer	
DS = device signaling (lamp)	M = meter	TB = terminal board	
E = misc electronic part	MK = microphone	TP = test point	

ABBREVIATIONS

A = amperes	H = henries	N/O = normally open	RMO = rack mount only
AFC = automatic frequency control	HDW = hardware	NPO = negative positive zero (zero temperature coefficient)	RMS = root-mean square
AMPL = amplifier	HEX = hexagonal	NPN = negative-positive-negative	RWV = reverse working voltage
BFO = beat frequency oscillator	HG = mercury	NRF = not recommended for field replacement	S-B = slow-blow
BE CU = beryllium copper	HR = hour(s)	NSR = not separately replaceable	SCR = screw
BH = binder head	HZ = hertz	OBD = order by description	SE = selenium
BP = bandpass	IF = intermediate freq	OH = oval head	SECT = section(s)
BRS = brass	IMPG = impregnated	OX = oxide	SEMICON = semiconductor
BWO = backward wave oscillator	INCD = incandescent	P = peak	SI = silicon
CCW = counter-clockwise	INCL = include(s)	PC = printed circuit	SIL = silver
CER = ceramic	INS = insulation(ed)	PF = picofarads = 10 ⁻¹² farads	SL = slide
CMO = cabinet mount only	DNT = internal	PH BRZ = phosphor bronze	SPG = spring
COEF = coefficient	K = kilo = 1000	PHL = Phillips	SPL = special
COM = common	LH = left hand	PIV = peak inverse voltage	SST = stainless steel
COMP = composition	LIN = linear taper	PNP = positive-negative-positive	SR = split ring
COMPL = complete	LK WASH = lock washer	P/O = part of	STL = steel
CONN = connector	LOG = logarithmic taper	POLY = polystyrene	TA = tantalum
CP = cadmium plate	LPF = low pass filter	PORC = porcelain	TD = time delay
CRT = cathode-ray tube	M = milli = 10 ⁻³	POS = position(s)	TGL = toggle
CW = clockwise	MEG = meg = 10 ⁶	POT = potentiometer	THD = thread
DEPC = deposited carbon	MET FLM = metal film	PP = peak-to-peak	TI = titanium
DR = drive	MET OX = metallic oxide	PT = point	TOL = tolerance
ELECT = electrolytic	MFR = manufacturer	PWV = peak working voltage	TRIM = trimmer
ENCAP = encapsulated	MHZ = mega hertz	RECT = rectifier	TWT = traveling wave tube
EXT = external	MINAT = miniature	RF = radio frequency	U = micro = 10 ⁻⁶
F = farads	MOM = momentary	RH = round head or right hand	VAR = variable
FH = flat head	MTG = mounting		VDCW = dc working volts
FIL H = fillister head	MY = "mylar"		W/ = with
FXD = fixed	N = nano (10 ⁻⁹)		W = watts
GE = germanium	N/C = normally closed		WIV = working inverse voltage
GL = glass	NE = neon		WW = wirewound
GRD = ground(ed)	NI PL = nickel plate		W/O = without

www.valuetronics.com

Table 6-1. Reference Designation Index

Reference Designation	Part No.	Description #	Note
A1	08709-6003	POWER SUPPLY/AMPL ASSY	
	08709-2003	BOARD:BLANK PC	
A1C1	0180-0058	C:FXD ELECT 50UF -10%+100% 25VDCW	
A1C2	0180-0049	C:FXD AL ELECT 20UF 50VDCW	
A1C3	0180-0061	C:FXD ELECT 100UF +100%-10% 15VDCW	
A1C4	0150-0121	C:FXD CER 0.1 UF +80-20% 50VDCW	
A1C5	0180-0129	C:FXD ELECT 975UF -10+50% 40VDCW	
A1C6	0180-0058	C:FXD ELECT 50UF -10%+100% 25VDCW	
A1C7	0180-0049	C:FXD AL ELECT 20UF 50VDCW	
A1C8	0180-0061	C:FXD ELECT 100UF +100%-10% 15VDCW	
A1C9	0150-0121	C:FXD CER 0.1 UF +80-20% 50VDCW	
A1C10	0180-0129	C:FXD ELECT 975UF -10+50% 40VDCW	
A1C11		NOT ASSIGNED	
A1C12	0160-0137	C:FXD CER 0.33 UF 20% 25VDCW	
A1C13	0160-0168	C:FXD MY 0.1 UF 10% 200VDCW	
A1C14	0160-0168	C:FXD MY 0.1 UF 10% 200VDCW	
A1C15	0150-0093	C:FXD CER 0.01 UF +80-20% 100VDCW	
A1C16	0150-0093	C:FXD CER 0.01 UF +80-20% 100VDCW	
A1C17	0180-1735	C:FXD ELECT 0.22 UF 10% 35VDCW	
A1C18	0170-0040	C:FXD MY .047 UF 10% 200VDCW	
A1CR1	1901-0025	DIODE:SILICON 100WV 100MA	
A1CR2	1901-0025	DIODE:SILICON 100WV 100MA	
A1CR3	1901-0025	DIODE:SILICON 100WV 100MA	
A1CR4	1901-0026	DIODE:SILICON 0.75A 200 PIV	
A1CR5	1901-0026	DIODE:SILICON 0.75A 200 PIV	
A1CR6	1901-0026	DIODE:SILICON 0.75A 200 PIV	
A1CR7	1901-0026	DIODE:SILICON 0.75A 200 PIV	
A1CR8		NOT ASSIGNED	
A1CR9		NOT ASSIGNED	
A1CR10	1901-0025	DIODE:SILICON 100WV 100MA	
A1CR11		NOT ASSIGNED	
A1CR12	1901-0026	DIODE:SILICON 0.75A 200 PIV	
A1CR13	1901-0026	DIODE:SILICON 0.75A 200 PIV	
A1CR14	1901-0026	DIODE:SILICON 0.75A 200 PIV	
A1CR15	1901-0026	DIODE:SILICON 0.75A 200 PIV	
A1CR16	1901-0025	DIODE:SILICON 100WV 100MA	
A1CR17	1901-0025	DIODE:SILICON 100WV 100MA	
A1CR18	1901-0025	DIODE:SILICON 100WV 100MA	
A1Q1	1854-0063	TRANSISTOR:NPN SILICON 2N3055	
	2420-0003	NUT:HEX SST 6-32	
	2460-0013	SCREW:STL PHIL DR PAN HD 6-32	
	2190-0006	WASHER:SPLIT LOCK FOR #6 SCREW	
A1Q2	1853-0016	TRANSISTOR:SILICON PNP 2N3638	

www.valuetronics.com

See introduction to this section for ordering information

Table 6-1. Reference Designation Index (Cont.)

Reference Designation	Part No.	Description #	Note
A1Q3	1854-0039	TRANSISTOR:SILICON 2N3053	
A1Q4	1853-0016	TRANSISTOR:SILICON PNP 2N3638	
A1Q5	1854-0039	TRANSISTOR:SILICON 2N3053	
A1Q6	1854-0039	TRANSISTOR:SILICON 2N3053	
A1Q7	1854-0063	TRANSISTOR:NPN SILICON 2N3055	
	2420-0003	NUT:HEX SST 6-32	
	2460-0013	SCREW:STL PHIL DR PAN HD 6-32	
	2190-0006	WASHER:SPLIT LOCK FOR #6 SCREW	
A1Q8	1854-0039	TRANSISTOR:SILICON 2N3053	
A1Q9	1853-0016	TRANSISTOR:SILICON PNP 2N3638	
A1Q10	1853-0016	TRANSISTOR:SILICON PNP 2N3638	
A1Q11	1854-0071	TRANSISTOR:SILICON NPN	
A1Q12	1854-0071	TRANSISTOR:SILICON NPN	
A1Q13	1853-0036	TRANSISTOR:SILICON PNP	
A1Q14	1853-0036	TRANSISTOR:SILICON PNP	
A1Q15	1853-0012	TRANSISTOR:PNP SILICON 2N2904A	
A1Q16	1854-0039	TRANSISTOR:SILICON 2N3053	
A1Q17	1854-0039	TRANSISTOR:SILICON 2N3053	
A1R1	0757-0439	R:FXD MET FLM 6.81K OHM 1% 1/8W	
A1R2	0757-0442	R:FXD MET FLM 10.0K OHM 1% 1/8W	
A1R3	0757-0438	R:FXD MET FLM 5.11K OHM 1% 1/8W	
A1R4	0698-3156	R:FXD MET FLM 14.7K OHM 1% 1/8W	
A1R5	0698-3453	R:FXD MET FLM 196K OHM 1% 1/8W	
A1R6	0757-0442	R:FXD MET FLM 10.0K OHM 1% 1/8W	
A1R7	0757-0279	R:FXD MET FLM 3.16K OHM 1% 1/8W	
A1R8	0811-1670	R:FXD WW 2.2 OHM 5% 2W	
A1R9	0812-0086	R:FXD WW 5 OHM 5% 3W	
A1R10	0757-0280	R:FXD MET FLM 1K OHM 1% 1/8W	
A1R11	0757-0439	R:FXD MET FLM 6.81K OHM 1% 1/8W	
A1R12	0757-0442	R:FXD MET FLM 10.0K OHM 1% 1/8W	
A1R13	0757-0438	R:FXD MET FLM 5.11K OHM 1% 1/8W	
A1R14	0698-3156	R:FXD MET FLM 14.7K OHM 1% 1/8W	
A1R15	0698-3453	R:FXD MET FLM 196K OHM 1% 1/8W	
A1R16	0757-0442	R:FXD MET FLM 10.0K OHM 1% 1/8W	
A1R17	0757-0279	R:FXD MET FLM 3.16K OHM 1% 1/8W	
A1R18	0811-1670	R:FXD WW 2.2 OHM 5% 2W	
A1R19	0812-0086	R:FXD WW 5 OHM 5% 3W	
A1R20	0757-0280	R:FXD MET FLM 1K OHM 1% 1/8W	
A1R21	0757-0280	R:FXD MET FLM 1K OHM 1% 1/8W	
A1R22	0698-0084	R:FXD MET FLM 2.15K OHM 1% 1/8W	
A1R23	0698-3153	R:FXD MET FLM 3.83K OHM 1% 1/8W	
A1R24	0698-0084	R:FXD MET FLM 2.15K OHM 1% 1/8W	
A1R25	0757-0379	R:FXD MET FLM 12.1 OHM 1% 1/8W	
A1R26	0757-0462	R:FXD MET FLM 75.0K OHM 1% 1/8W	
A1R27	0698-3151	R:FXD MET FLM 2.87K OHM 1% 1/8W	
A1R28	0757-0438	R:FXD MET FLM 5.11K OHM 1% 1/8W	
A1R29	0757-0416	R:FXD MET FLM 511 OHM 1% 1/8W	
A1R30	0757-0394	R:FXD MET FLM 51.1 OHM 1% 1/8W	

www.valuetronics.com

See introduction to this section for ordering information

Table 6-1. Reference Designation Index (Cont.)

Reference Designation	Part No.	Description #	Note
A1R31	0757-0394	R:FXD MET FLM 51.1 OHM 1% 1/8W	
A1R32	0698-3160	R:FXD MET FLM 31.6K OHM 1% 1/8W	
A1R33	0698-0084	R:FXD MET FLM 2.15K OHM 1% 1/8W	
A1R34	0698-3449	R:FXD MET FLM 28.7K OHM 1% 1/8W	
A1R35	0698-3136	R:FXD MET FLM 17.8K OHM 1% 1/8W	
A1R36	0698-3136	R:FXD MET FLM 17.8K OHM 1% 1/8W	
A1R37	2100-1772	R:VAR WW 500 OHM 10% LIN 1/2W	
A1R38		NOT ASSIGNED	
A1R39	0698-3629	R:FXD MET OX 270 OHM 5% 2W	
A1R40		NOT ASSIGNED	
A1R41	0757-0280	R:FXD MET FLM 1K OHM 1% 1/8W	
A1R42	0757-0280	R:FXD MET FLM 1K OHM 1% 1/8W	
A1R43	0698-3440	R:FXD MET FLM 196 OHM 1% 1/8W	
A1R44	0757-0419	R:FXD MET FLM 681 OHM 1% 1/8W	
A1T1	9100-2469	TRANSFORMER	
	2700-0002	SCREW:SST PHIL DR PAN HD 10-32	
	2190-0091	WASHER:LOCK FOR #10 HDW	
	2740-0005	NUT:HEX STL 10-32	
A1TP1	0360-0124	TERMINAL:SOLDER LUG	
A1TP2	0360-0124	TERMINAL:SOLDER LUG	
A1TP3	0360-0124	TERMINAL:SOLDER LUG	
	1200-0063	LUG:CRIMP	
A1TP4	0360-0124	TERMINAL:SOLDER LUG	
	1200-0063	LUG:CRIMP	
A1VR1	1902-0049	DIODE,BREAKDOWN: 6.19V 5%	
A1VR2	1902-3048	DIODE BREAKDOWN:SILICON 3.48V 5%	
A1VR3	1902-0049	DIODE,BREAKDOWN: 6.19V 5%	
A1VR4	1902-3048	DIODE BREAKDOWN:SILICON 3.48V 5%	
A1ZISC	0380-0336	STANDOFF	
A2	08709-6005	CASTING ASSY(SHIELD)	
	08709-2000	CASTING:PC HOUSING	
	08709-0003	COVER:UPPER PC HOUSING	
	08709-0004	COVER:LOWER PC HOUSING	
	2515-0004	SCREW:STL PHIL DR PAN HD 8-32	
	0360-0042	TERMINAL:SOLDER LUG FOR #6 SCREW	
	2190-0476	WASHER:LOCK FOR #4 HDW	
	2270-0004	SCREW:STL PHIL DR PAN HD 4-40	
	0340-0008	INSULATOR:STANDOFF TEFLON	
	2190-0058	WASHER:LOCK FOR #8 HDW	
A2C1	0160-2437	C:FXD CER 5000 PF +80-20% 200VDCW	
A2C2	0160-2437	C:FXD CER 5000 PF +80-20% 200VDCW	
A2C3	0160-2437	C:FXD CER 5000 PF +80-20% 200VDCW	
A2C4	0160-2248	C:FXD CER 4.3 0.25 PF 500VDCW	
A2C5	0160-2308	C:FXD MICA 36 PF 5%	

www.valuetronics.com

See introduction to this section for ordering information

Table 6-1. Reference Designation Index (Cont.)

Reference Designation	Part No.	Description #	Note
A2C6	0160-2238	C:FXD CER 1.5-0.25 PF 500VDCW	
A2C7	0160-2437	C:FXD CER 5000 PF +80-20% 200VDCW	
A2C8	0160-2437	C:FXD CER 5000 PF +80-20% 200VDCW	
A2C9	0160-2436	C:FXD CER 10 PF 20% 200VDCW	
A2C10	0160-2437	C:FXD CER 5000 PF +80-20% 200VDCW	
A2C11	0160-2438	C:FXD CER 5000 PF +80-20% 200VDCW	
A2C12	0160-2438	C:FXD CER 5000 PF +80-20% 200VDCW	
A2C13	0160-2437	C:FXD CER 5000 PF +80-20% 200VDCW	
A2J1	1250-0083	CONNECTOR:BNC	
A2J2		NOT ASSIGNED	
A2J3	1250-0083	CONNECTOR:BNC	
A2L1	9100-1621	COIL/CHOKE 18 UH 10%	
A2L2	9140-0121	COIL:FXD 1.8 UH	
A2L3	9100-1623	COIL/CHOKE 27 UH 5%	
A2L4	9140-0114	COIL:FXD RF 10 UH	
A2L5	9140-0114	COIL:FXD RF 10 UH	
A2L6	9140-0114	COIL:FXD RF 10 UH	
A2L7	9140-0114	COIL:FXD RF 10 UH	
A2L8	9100-1625	COIL:MOLDED CHOKE 330 UH 5%	
A2L9	9100-1625	COIL:MOLDED CHOKE 330 UH 5%	
A2L10	9140-0137	COIL:FXD RF 1 MH 5%	
A2R1	0757-0401	R:FXD MET FLM 100 OHM 1% 1/8W	
A2R2	0698-3153	R:FXD MET FLM 3.83K OHM 1% 1/8W	
A2R3	0698-3153	R:FXD MET FLM 3.83K OHM 1% 1/8W	
A2R4	0757-0280	R:FXD MET FLM 1K OHM 1% 1/8W	
A2R5	0757-0438	R:FXD MET FLM 5.11K OHM 1% 1/8W	
A2XA3	1251-0159	CONNECTOR:2X15 CONTACT	
	2460-0014	SCREW:STL PHIL DR PAN HD 6-32	
	2190-0065	WASHER:LOCK FOR #6 HDW	
A2XA4	1251-0159	CONNECTOR:2X15 CONTACT	
	2460-0014	SCREW:STL PHIL DR PAN HD 6-32	
	2190-0065	WASHER:LOCK FOR #6 HDW	
A2XA5	1251-0160	CONNECTOR:15 PIN	
	2460-0014	SCREW:STL PHIL DR PAN HD 6-32	
	2190-0065	WASHER:LOCK FOR #6 HDW	
A2XA6	1251-0160	CONNECTOR:15 PIN	
	2460-0014	SCREW:STL PHIL DR PAN HD 6-32	
	2190-0065	WASHER:LOCK FOR #6 HDW	
A2XA7	1251-0160	CONNECTOR:15 PIN	
	2460-0014	SCREW:STL PHIL DR PAN HD 6-32	
	2190-0065	WASHER:LOCK FOR #6 HDW	
A2XA8	1251-0160	CONNECTOR:15 PIN	
	2190-0065	WASHER:LOCK FOR #6 HDW	
	2460-0014	SCREW:STL PHIL DR PAN HD 6-32	
A3	08709-6001	PREAMPLIFIER ASSY	

Table 6-1. Reference Designation Index (Cont.)

Reference Designation	Part No.	Description #	Note
A3C1	0160-2257	C:FXD CER 10 PF 5% 500VDCW	
A3C2	0160-2204	C:FXD MICA 100 PF 5%	
A3C3	0150-0093	C:FXD CER 0.01 UF +80-20% 100VDCW	
A3C4	0150-0093	C:FXD CER 0.01 UF +80-20% 100VDCW	
A3C5	0150-0093	C:FXD CER 0.01 UF +80-20% 100VDCW	
A3C6	0150-0093	C:FXD CER 0.01 UF +80-20% 100VDCW	
A3C7	0150-0093	C:FXD CER 0.01 UF +80-20% 100VDCW	
A3C8	0160-2204	C:FXD MICA 100 PF 5%	
A3IC1	1820-0306	INTEGRATED CIRCUIT	
A3IC2	1820-0306	INTEGRATED CIRCUIT	
A3L1	9140-0105	COIL:MOLDED CHOKE 8.20 UH 10%	
A3L2	9140-0105	COIL:MOLDED CHOKE 8.20 UH 10%	
A3R1	0757-0279	R:FXD MET FLM 3.16K OHM 1% 1/8W	
A3R2	0757-1094	R:FXD MET FLM 1.47K OHM 1% 1/8W	
A3R3	0757-1094	R:FXD MET FLM 1.47K OHM 1% 1/8W	
A3R4	0757-0280	R:FXD MET FLM 1K OHM 1% 1/8W	
A3R5	0757-0279	R:FXD MET FLM 3.16K OHM 1% 1/8W	
A3R6	0698-3445	R:FXD MET FLM 348 OHM 1% 1/8W	
A3R7	0757-0401	R:FXD MET FLM 100 OHM 1% 1/8W	
A3R8	0757-0420	R:FXD MET FLM 750 OHM 1% 1/8W	
A3R9	0757-1094	R:FXD MET FLM 1.47K OHM 1% 1/8W	
A3R10	0757-0279	R:FXD MET FLM 3.16K OHM 1% 1/8W	
A3T1	08709-6006	TRANSFORMER ASSY	
A4	08709-6002	AMPLIFIER ASSY	
A4C1	0150-0093	C:FXD CER 0.01 UF +80-20% 100VDCW	
A4C2	0150-0093	C:FXD CER 0.01 UF +80-20% 100VDCW	
A4C3	0150-0093	C:FXD CER 0.01 UF +80-20% 100VDCW	
A4C4	0150-0093	C:FXD CER 0.01 UF +80-20% 100VDCW	
A4C5	0150-0093	C:FXD CER 0.01 UF +80-20% 100VDCW	
A4C6	0150-0093	C:FXD CER 0.01 UF +80-20% 100VDCW	
A4C7	0160-2204	C:FXD MICA 100 PF 5%	
A4C8	0180-0376	C:FXD ELECT 0.47 UF 10% 35VDCW	
A4C9	0180-0197	C:FXD ELECT 2.2 UF 10% 20VDCW	
A4CR1	1910-0022	DIODE:GERMANIUM 5 WIV	
A4IC1	1820-0306	INTEGRATED CIRCUIT	
A4IC2	1820-0306	INTEGRATED CIRCUIT	
A4L1	9140-0105	COIL:MOLDED CHOKE 8.20 UH 10%	

www.valuetronics.com

See introduction to this section for ordering information

Table 6-1. Reference Designation Index (Cont.)

Reference Designation	Part No.	Description #	Note
A4L2	9140-0105	COIL:MOLDED CHOKE 8.20 UH 10%	
A4Q1	1854-0092	TRANSISTOR:SILICON NPN 2N3563	
A4Q2	1854-0039	TRANSISTOR:SILICON 2N3053	
A4R1	0757-0394	R:FXD MET FLM 51.1 OHM 1% 1/8W	
A4R2	0757-0420	R:FXD MET FLM 750 OHM 1% 1/8W	
A4R3	0757-1094	R:FXD MET FLM 1.47K OHM 1% 1/8W	
A4R4	0757-0279	R:FXD MET FLM 3.16K OHM 1% 1/8W	
A4R5	0757-0420	R:FXD MET FLM 750 OHM 1% 1/8W	
A4R6	0757-0401	R:FXD MET FLM 100 OHM 1% 1/8W	
A4R7	0757-1094	R:FXD MET FLM 1.47K OHM 1% 1/8W	
A4R8	0757-0424	R:FXD MET FLM 1.10K OHM 1% 1/8W	
A4R9	0698-3444	R:FXD MET FLM 316 OHM 1% 1/8W	
A4R10	0757-0280	R:FXD MET FLM 1K OHM 1% 1/8W	
A4R11	0757-0442	R:FXD MET FLM 10.0K OHM 1% 1/8W	
A4R12	0757-0279	R:FXD MET FLM 3.16K OHM 1% 1/8W	
A4R13	0757-0796	R:FXD MET FLM 82.5 OHM 1% 1/2W	
A4VR1	1902-3193	DIODE BREAKDOWN:13.3V 5%	
A5	08709-6007	PHASE DETECTOR ASSY	
	08410-2006	BOARD:BLANK PC	
A5C1		NOT ASSIGNED	
A5C2	0160-2197	C:FXD MICA 10 PF 5%	
A5C3	0140-0192	C:FXD MICA 68 PF 5%	
A5C4	0150-0093	C:FXD CER 0.01 UF +80-20% 100VDCW	
A5C5	0150-0093	C:FXD CER 0.01 UF +80-20% 100VDCW	
A5C6	0160-2263	C:FXD CER 18 PF 5% 500VDCW	
A5C7	0150-0093	C:FXD CER 0.01 UF +80-20% 100VDCW	
A5C8	0150-0093	C:FXD CER 0.01 UF +80-20% 100VDCW	
A5C9	0150-0093	C:FXD CER 0.01 UF +80-20% 100VDCW	
A5C10	0160-2307	C:FXD MICA 47 PF 5%	
A5C11	0160-2307	C:FXD MICA 47 PF 5%	
A5C12	0160-2307	C:FXD MICA 47 PF 5%	
A5C13	0160-2307	C:FXD MICA 47 PF 5%	
A5C14	0150-0093	C:FXD CER 0.01 UF +80-20% 100VDCW	
A5C15	0150-0093	C:FXD CER 0.01 UF +80-20% 100VDCW	
A5C16	0160-2230	C:FXD MICA 3300 PF 5%	
A5C17	0140-0177	C:FXD MICA 400 PF 1%	
A5CR1	1901-0179	DIODE:SILICON 15WV	
A5CR2	1901-0179	DIODE:SILICON 15WV	
A5CR3	1901-0179	DIODE:SILICON 15WV	
A5CR4	1901-0179	DIODE:SILICON 15WV	
A5CR5	1901-0179	DIODE:SILICON 15WV	

www.valuetronics.com

See introduction to this section for ordering information

Table 6-1. Reference Designation Index (Cont.)

Reference Designation	Part No.	Description #	Note
A5CR6	1901-0179	DIODE:SILICON 15WV	
A5CR7	1901-0179	DIODE:SILICON 15WV	
A5CR8	1901-0179	DIODE:SILICON 15WV	
A5CR9	1901-0022	DIODE:SILICON 0.56V AT 1 MA	
A5CR10	1901-0022	DIODE:SILICON 0.56V AT 1 MA	
A5L1		NOT ASSIGNED	
A5L2	9100-1618	COIL:MOLDED CHOKE 5.60 UH	
A5L3	9100-1614	COIL/CHOKE:0.82 UH 10%	
A5L4	9140-0121	COIL:FXD 1.8 UH	
A5L5	9100-2230	COIL/CHOKE:.15 UH 3%	
A5Q1	1854-0071	TRANSISTOR:SILICON NPN	
A5Q2	1854-0071	TRANSISTOR:SILICON NPN	
A5Q3	1854-0071	TRANSISTOR:SILICON NPN	
A5Q4	1854-0092	TRANSISTOR:SILICON NPN 2N3563	
A5Q5	1854-0092	TRANSISTOR:SILICON NPN 2N3563	
A5Q6	1854-0092	TRANSISTOR:SILICON NPN 2N3563	
A5R1	0757-0416	R:FXD MET FLM 511 OHM 1% 1/8W	
A5R2	0757-0438	R:FXD MET FLM 5.11K OHM 1% 1/8W	
A5R3	0757-0441	R:FXD MET FLM 8.25K OHM 1% 1/8W	
A5R4	0757-0416	R:FXD MET FLM 511 OHM 1% 1/8W	
A5R5	0757-0438	R:FXD MET FLM 5.11K OHM 1% 1/8W	
A5R6	0757-0441	R:FXD MET FLM 8.25K OHM 1% 1/8W	
A5R7	0698-3446	R:FXD MET FLM 383 OHM 1% 1/8W	
A5R8	0757-0199	R:FXD MET FLM 21.5K OHM 1% 1/8W	
A5R9	0757-0199	R:FXD MET FLM 21.5K OHM 1% 1/8W	
A5R10	0757-0401	R:FXD MET FLM 100 OHM 1% 1/8W	
A5R11	0757-0280	R:FXD MET FLM 1K OHM 1% 1/8W	
A5R12	0757-0401	R:FXD MET FLM 100 OHM 1% 1/8W	
A5R13	0757-0402	R:FXD MET FLM 110 OHM 1% 1/8W	
A5R14	0757-0401	R:FXD MET FLM 100 OHM 1% 1/8W	
A5R15	0757-0438	R:FXD MET FLM 5.11K OHM 1% 1/8W	
A5R16	0698-0083	R:FXD MET FLM 1.96K OHM 1% 1/8W	
A5R17	0698-3443	R:FXD MET FLM 287 OHM 1% 1/8W	
A5R18	0698-0083	R:FXD MET FLM 1.96K OHM 1% 1/8W	
A5R19	0698-3443	R:FXD MET FLM 287 OHM 1% 1/8W	
A5R20	0757-0401	R:FXD MET FLM 100 OHM 1% 1/8W	
A5R21	0698-3155	R:FXD MET FLM 4.64K OHM 1% 1/8W	
A5R22	0757-0438	R:FXD MET FLM 5.11K OHM 1% 1/8W	
A5R23	0757-0401	R:FXD MET FLM 100 OHM 1% 1/8W	
A5R24	0757-0280	R:FXD MET FLM 1K OHM 1% 1/8W	
A5R25	0698-3154	R:FXD MET FLM 4.22K OHM 1% 1/8W	
A5R26	0698-3154	R:FXD MET FLM 4.22K OHM 1% 1/8W	
A5R27	0698-3154	R:FXD MET FLM 4.22K OHM 1% 1/8W	
A5R28	0698-3154	R:FXD MET FLM 4.22K OHM 1% 1/8W	
A5R29	0698-3440	R:FXD MET FLM 196 OHM 1% 1/8W	
A5R30	0698-3440	R:FXD MET FLM 196 OHM 1% 1/8W	

www.valuetronics.com

See introduction to this section for ordering information

Table 6-1. Reference Designation Index (Cont.)

Reference Designation	Part No.	Description #	Note
A6	08709-6008	OSCILLATOR ASSY:20MHZ	
	08410-2009	BOARD:BLANK PC	
A6C1	0150-0093	C:FXD CER 0.01 UF +80-20% 100VDCW	
A6C2	0150-0093	C:FXD CER 0.01 UF +80-20% 100VDCW	
A6C3	0150-0093	C:FXD CER 0.01 UF +80-20% 100VDCW	
A6C4	0150-0093	C:FXD CER 0.01 UF +80-20% 100VDCW	
A6C5	0140-0199	C:FXD MICA 240 PF 5%	
A6C6		NDT ASSIGNED	
A6C7	0160-2218	C:FXD MICA 1000 PF 5%	
A6C8	0140-0205	C:FXD MICA 62 PF 5%	
A6C9	0160-2204	C:FXD MICA 100 PF 5%	
A6C10	0150-0093	C:FXD CER 0.01 UF +80-20% 100VDCW	
A6C11	0160-2204	C:FXD MICA 100 PF 5%	
A6C12	0150-0093	C:FXD CER 0.01 UF +80-20% 100VDCW	
A6C13	0150-0093	C:FXD CER 0.01 UF +80-20% 100VDCW	
A6C14	0150-0093	C:FXD CER 0.01 UF +80-20% 100VDCW	
A6CR1	1910-0020	DIODE:GERMANIUM 1N55A	
A6CR2	1910-0020	DIODE:GERMANIUM 1N55A	
A6L1	9100-1631	COIL/CHOKER 56 UH 5%	
A6L2	08709-6009-1	COIL:20MHZ,ADJ. 0.4-1.0 UH	
A6Q1	1854-0092	TRANSISTOR:SILICON NPN 2N3563	
A6Q2	1854-0092	TRANSISTOR:SILICON NPN 2N3563	
A6Q3	1853-0015	TRANSISTOR:SILICON PNP 2N3640	
A6R1	0698-0083	R:FXD MET FLM 1.96K OHM 1% 1/8W	
A6R2	0757-0289	R:FXD MET FLM 13.3K OHM 1% 1/8W	
A6R3	0698-3157	R:FXD MET FLM 19.6K OHM 1% 1/8W	
A6R4	0757-0280	R:FXD MET FLM 1K OHM 1% 1/8W	
A6R5	0757-0280	R:FXD MET FLM 1K OHM 1% 1/8W	
A6R6	0698-3440	R:FXD MET FLM 196 OHM 1% 1/8W	
A6R7	0757-0279	R:FXD MET FLM 3.16K OHM 1% 1/8W	
A6R8	0757-0401	R:FXD MET FLM 100 OHM 1% 1/8W	
A6R9	0757-0442	R:FXD MET FLM 10.0K OHM 1% 1/8W	
A6R10	0757-0438	R:FXD MET FLM 5.11K OHM 1% 1/8W	
A6R11	0757-0401	R:FXD MET FLM 100 OHM 1% 1/8W	
A6R12	0757-0422	R:FXD MET FLM 909 OHM 1% 1/8W	
A6R13	0698-3153	R:FXD MET FLM 3.83K OHM 1% 1/8W	
A6R14	0698-3440	R:FXD MET FLM 196 OHM 1% 1/8W	
A6R15	0698-0083	R:FXD MET FLM 1.96K OHM 1% 1/8W	
A6XY1	1200-0191	SOCKET:CRYSTAL	

www.valuetronics.com

See introduction to this section for ordering information

Table 6-1. Reference Designation Index (Cont.)

Reference Designation	Part No.	Description #	Note
A6Y1	0410-0159	CRYSTAL:QUARTZ 20MHZ	
A7	08709-6004	LOCK MODE SWITCH ASSY	
	08410-2041	BOARD:BLANK PC	
A7C1	0160-2230	C:FXD MICA 3300 PF 5%	
A7C2	0160-0167	C:FXD MY 0.082 UF 10% 200VDCW	
A7C3	0160-2209	C:FXD MICA 360 PF 5%	
A7C4	0180-0374	C:FXD ELECT 10 UF 10% 20VDCW	
A7C5	0150-0121	C:FXD CER 0.1 UF +80-20% 50VDCW	
A7C6	0150-0121	C:FXD CER 0.1 UF +80-20% 50VDCW	
A7C7	0150-0121	C:FXD CER 0.1 UF +80-20% 50VDCW	
A7C8	0160-0159	C:FXD MY 0.0068 UF 10% 200VDCW	
A7CR1	1901-0025	DIODE:SILICON 100WV 100MA	
A7CR2	1901-0025	DIODE:SILICON 100WV 100MA	
A7Q1	1854-0071	TRANSISTOR:SILICON NPN	
A7Q2	1854-0071	TRANSISTOR:SILICON NPN	
A7Q3	1853-0020	TRANSISTOR:SILICON PNP	
A7Q4	1855-0078	TRANSISTOR:FIELD EFFECT 40 OHM 6V	
A7Q5	1854-0071	TRANSISTOR:SILICON NPN	
A7Q6	1854-0071	TRANSISTOR:SILICON NPN	
A7Q7	1854-0071	TRANSISTOR:SILICON NPN	
A7Q8	1854-0071	TRANSISTOR:SILICON NPN	
A7R1	0698-3260	R:FXD MET FLM 464K OHM 1% 1/8W	
A7R2	0757-0461	R:FXD MET FLM 68.1K OHM 1% 1/8W	
A7R3	0757-0442	R:FXD MET FLM 10.0K OHM 1% 1/8W	
A7R4	0698-3451	R:FXD MET FLM 133K OHM 1% 1/8W	
A7R5	0757-0416	R:FXD MET FLM 511 OHM 1% 1/8W	
A7R6	0757-0421	R:FXD MET FLM 825 OHM 1% 1/8W	
A7R7	0757-0276	R:FXD MET FLM 61.9 OHM 1% 1/8W	
A7R8	0757-0458	R:FXD MET FLM 51.1K OHM 1% 1/8W	
A7R9	0757-0438	R:FXD MET FLM 5.11K OHM 1% 1/8W	
A7R10	2100-0942	R:VAR MET FLM 50K OHM 20% TYPE V	
A7R11	0698-3153	R:FXD MET FLM 3.83K OHM 1% 1/8W	
A7R12	0698-3438	R:FXD MET FLM 147 OHM 1% 1/8W	
A7R13	0757-0288	R:FXD MET FLM 9.09K OHM 1% 1/8W	
A7R14	0757-0442	R:FXD MET FLM 10.0K OHM 1% 1/8W	
A7R15	0698-3438	R:FXD MET FLM 147 OHM 1% 1/8W	
A7R16	0698-3450	R:FXD MET FLM 42.2K OHM 1% 1/8W	
A7R17	0698-3155	R:FXD MET FLM 4.64K OHM 1% 1/8W	
A7R18	0757-0463	R:FXD MET FLM 82.5K OHM 1% 1/8W	
A7R19	0757-0462	R:FXD MET FLM 75.0K OHM 1% 1/8W	
A7R20	0757-0447	R:FXD MET FLM 16.2K OHM 1% 1/8W	

www.valuetronics.com

See introduction to this section for ordering information

Table 6-1. Reference Designation Index (Cont.)

Reference Designation	Part No.	Description #	Note
A7R21	0757-0416	R:FXD MET FLM 511 OHM 1% 1/8W	
A7R22	0698-3154	R:FXD MET FLM 4.22K OHM 1% 1/8W	
A7R23	0757-0442	R:FXD MET FLM 10.0K OHM 1% 1/8W	
A7R24	0698-3444	R:FXD MET FLM 316 OHM 1% 1/8W	
A7R25	0698-3444	R:FXD MET FLM 316 OHM 1% 1/8W	
A7R26	0757-0419	R:FXD MET FLM 681 OHM 1% 1/8W	
A7R27	0757-0416	R:FXD MET FLM 511 OHM 1% 1/8W	
A8	08410-2007	SEARCH GENERATOR ASSY	
	08410-2007	BOARD:BLANK PC	
A8C1	0160-0168	C:FXD MY 0.1 UF 10% 200VDCW	
A8Q1	1854-0071	TRANSISTOR:SILICON NPN	
A8Q2	1854-0071	TRANSISTOR:SILICON NPN	
A8Q3	1853-0020	TRANSISTOR:SILICON PNP	
A8Q4	1853-0020	TRANSISTOR:SILICON PNP	
A8Q5	1853-0020	TRANSISTOR:SILICON PNP	
A8Q6	1854-0071	TRANSISTOR:SILICON NPN	
A8Q7	1853-0020	TRANSISTOR:SILICON PNP	
A8Q8	1853-0020	TRANSISTOR:SILICON PNP	
A8Q9	1853-0020	TRANSISTOR:SILICON PNP	
A8Q10	1853-0020	TRANSISTOR:SILICON PNP	
A8R1	0757-0417	R:FXD MET FLM 562 OHM 1% 1/8W	
A8R2	0757-0398	R:FXD MET FLM 75 OHM 1% 1/8W FACTORY SELECTED PART	
A8R3	0757-0428	R:FXD MET FLM 1.62K OHM 1% 1/8W	
A8R4	0757-0402	R:FXD MET FLM 110 OHM 1% 1/8W	
A8R5	0698-3446	R:FXD MET FLM 383 OHM 1% 1/8W	
A8R6	0698-0083	R:FXD MET FLM 1.96K OHM 1% 1/8W	
A8R7	0698-3156	R:FXD MET FLM 14.7K OHM 1% 1/8W	
A8R8	0757-0424	R:FXD MET FLM 1.10K OHM 1% 1/8W	
A8R9		NOT ASSIGNED	
A8R10		NOT ASSIGNED	
A8R11	0757-0200	R:FXD MET FLM 5.62K OHM 1% 1/8W	
A8R12	0757-0279	R:FXD MET FLM 3.16K OHM 1% 1/8W	
A8R13	0698-0083	R:FXD MET FLM 1.96K OHM 1% 1/8W	
A8R14	0757-0424	R:FXD MET FLM 1.10K OHM 1% 1/8W	
A8R15	0757-0443	R:FXD MET FLM 11.0K OHM 1% 1/8W	
A8R16	0698-3151	R:FXD MET FLM 2.87K OHM 1% 1/8W	
A8R17	0698-3443	R:FXD MET FLM 287 OHM 1% 1/8W	
A8R18	0757-0278	R:FXD MET FLM 1.78K OHM 1% 1/8W	
A8R19	0757-0441	R:FXD MET FLM 8.25K OHM 1% 1/8W	
A8R20	0757-0199	R:FXD MET FLM 21.5K OHM 1% 1/8W	
A8R21	0757-0199	R:FXD MET FLM 21.5K OHM 1% 1/8W	
A8R22	0757-0199	R:FXD MET FLM 21.5K OHM 1% 1/8W	
A8R23	0757-0199	R:FXD MET FLM 21.5K OHM 1% 1/8W	
A8R24	0757-0290	R:FXD MET FLM 6.19K OHM 1% 1/8W	

www.valuetronics.com

See introduction to this section for ordering information

Table 6-1. Reference Designation Index (Cont.)

Reference Designation	Part No.	Description #	Note
A8R25	0757-0290	R:FXD MET FLM 6.19K OHM 1% 1/8W	
A8R26	0757-0458	R:FXD MET FLM 51.1K OHM 1% 1/8W	
A8R27	0698-3159	R:FXD MET FLM 26.1K OHM 1% 1/8W	
A8R28	0698-3159	R:FXD MET FLM 26.1K OHM 1% 1/8W	
A8R29		NOT ASSIGNED	
A8R30	0757-0278	R:FXD MET FLM 1.78K OHM 1% 1/8W	
A8R31		NOT ASSIGNED	
A8R32	0698-3136	R:FXD MET FLM 17.8K OHM 1% 1/8W	
A8R33	0698-3450	R:FXD MET FLM 42.2K OHM 1% 1/8W	
A8R34	0757-0447	R:FXD MET FLM 16.2K OHM 1% 1/8W	
A8R35	0698-3446	R:FXD MET FLM 383 OHM 1% 1/8W	
A8R36	0698-0083	R:FXD MET FLM 1.96K OHM 1% 1/8W	
A8R37	0757-0402	R:FXD MET FLM 110 OHM 1% 1/8W	
A8R38	0757-0428	R:FXD MET FLM 1.62K OHM 1% 1/8W	
A8R39	0757-0401	R:FXD MET FLM 100 OHM 1% 1/8W	
A8R40	0757-0417	R:FXD MET FLM 562 OHM 1% 1/8W	
DS1	2140-0092	LAMP:5V 60 MA	
DS2	2140-0092	LAMP:5V 60 MA	
F1	2110-0064	FUSE:0.125A 125V SLO-BLO	
F1	2110-0018	FUSE:CARTRIDGE 0.25 AMP SLOW BLOW	
J1		NOT ASSIGNED	
J2	1250-0083	CONNECTOR:BNC	
J2	2190-0068	WASHER:LOCK PH BRZ NP 0.62X0.505X0.022	
J2	2950-0001	NUT:HEX BRS NP 3/8-32 X 1/2	
J3	1250-0083	CONNECTOR:BNC	
J3	2190-0068	WASHER:LOCK PH BRZ NP 0.62X0.505X0.022	
J3	2950-0001	NUT:HEX BRS NP 3/8-32 X 1/2	
M1	1120-1476	METER:500 UA	
M1	4040-0247	BEZEL:METER	
M1	1460-0256	SPRING:COMPRESSION	
MISC	7120-1254	TRADEMARK	
R27	2100-0467	R:VAR COMP 50K OHM 10% LIN 2.25W	
R27	1410-0052	BUSHING:POTENTIOMETER	
R27	2190-0016	WASHER:LOCK PH BRZ NP	
R27	2950-0034	NUT:HEX BRASS 3/8-32 X 1/2"	
S1	3101-0037	SWITCH:TOGGLE SPST	
S1	0590-0012	NUT:KNURLED 15/32-32	
S1	2950-0035	NUT:HEX BRASS 15/32-32	
S1	2190-0102	WASHER:LOCK PHOSPHOR BRONZE	
S2	3101-0903	SWITCH:SLIDE DP3T	
S3	3101-0070	SWITCH:SLIDE	
XDS1	2190-0067	WASHER:LOCK FOR 1/4" HDW	
XDS1	2950-0052	NUT:HEX BRASS 1/4-40	
XDS1	1450-0152	LAMPHOLDER:FOR T-1 SERIES	
XDS1	1450-0152	LEN:LAMPHOLDER RED PLASTIC	
XDS1	1450-0157	LENS:LAMPHOLDER	

See introduction to this section for ordering information

Table 6-1. Reference Designation Index (Cont.)

Reference Designation	Part No.	Description #	Note
XDS1 XDS2 XDS2 XDS2 XDS2	0360-0040 0360-0040 1450-0157 1450-0152 1450-0153	TERMINAL:SOLDER LUG TERMINAL:SOLDER LUG LENS:LAMPHOLDER LEN:LAMPHOLDER RED PLASTIC LAMPHOLDER:FOR T-1 SERIES	
XDS2 XDS2	2950-0052 2190-0067	NUT:HEX BRASS 1/4-40 WASHER:LOCK FOR 1/4" HDW	
XF1	1400-0084	FUSEHOLDER:EXTRACTOR POST TYPE	
XF1 XF1 XF1	0900-0016 2950-0038 2190-0037	"O" RING:11/16" NUT:HEX SST 1/2-24 X 11/16 WASHER:LOCK SST FOR 1/2 THREAD	

www.valuetronics.com

See introduction to this section for ordering information

Table 6-1. Reference Designation Index (Cont.)

Reference Designation	Part No.	Description #	Note
CABINET PARTS			
Figure 6-1. Cabinet Parts			
1	5060-0703	FRAME ASSY:6 X 11 SM	
2	1490-0032	STAND:TILT HALF-MODULE	
3	5040-0700	HINGE	
4	5060-0728	FOOT ASSY:HALF MODULE	
5	5020-0701	CABINET SPACER	
5	2360-0069	SCREW:STL PHIL DR FLAT HD 6-32	
5	2190-0179	WASHER:LOCK FOR #6 HDW	
6	5000-0703	SIDE COVER	
6	2370-0023	SCREW:SST PHIL DR FLAT HD 6-32	
7	5060-0720	COVER:HALF-RECESS TOP	
7	2370-0047	SCREW:SST PHIL DR 6-32	
8	5000-0717	COVER:HALF-MODULE BOTTOM	
8	2370-0047	SCREW:SST PHIL DR 6-32	
9	08709-0001	REAR PANEL	
9	2370-0035	SCREW:STL PHIL DR 6-32	
9	2190-0179	WASHER:LOCK FOR #6 HDW	
10	08709-0002	FRONT PANEL	

www.valuetronics.com

See introduction to this section for ordering information

Table 6-2. Replaceable Parts

Part No.	Description #	Mfr.	Mfr. Part No.	TQ
0140-0177	C:FXD MICA 400 PF 1%	28480	0140-0177	1
0140-0192	C:FXD MICA 68 PF 5%	28480	0140-0192	1
0140-0199	C:FXD MICA 240 PF 5%	28480	0140-0199	1
0140-0205	C:FXD MICA 62 PF 5%	28480	0140-0205	1
0150-0093	C:FXD CER 0.01 UF +80-20% 100VDCW	91418	TA	28
0150-0121	C:FXD CER 0.1 UF +80-20% 50VDCW	56289	5C508IS-CML	5
0160-0137	C:FXD CER 0.33 UF 20% 25VDCW	56289	5C10A7 CML	1
0160-0159	C:FXD MY 0.0068 UF 10% 200VDCW	28480	0160-0159	1
0160-0167	C:FXD MY 0.082 UF 10% 200VDCW	28480	0160-0167	1
0160-0168	C:FXD MY 0.1 UF 10% 200VDCW	28480	0160-0168	3
0160-2197	C:FXD MICA 10 PF 5%	28480	0160-2197	1
0160-2204	C:FXD MICA 100 PF 5%	28480	0160-2204	5
0160-2209	C:FXD MICA 360 PF 5%	28480	0160-2209	1
0160-2218	C:FXD MICA 1000 PF 5%	28480	0160-2218	1
0160-2230	C:FXD MICA 3300 PF 5%	28480	0160-2230	2
0160-2238	C:FXD CER 1.5-0.25 PF 500VDCW	72982	301-000-COKO-159C	1
0160-2248	C:FXD CER 4.3 0.25 PF 500VDCW	28480	0160-2248	1
0160-2257	C:FXD CER 10 PF 5% 500VDCW	72982	301-000-COHO-100J	1
0160-2263	C:FXD CER 18 PF 5% 500VDCW	72982	301-000-COGO-180J	1
0160-2307	C:FXD MICA 47 PF 5%	28480	0160-2307	4
0160-2308	C:FXD MICA 36 PF 5%	28480	0160-2308	1
0160-2436	C:FXD CER 10 PF 20% 200VDCW	72982	2425-000-X5P0-100M	1
0160-2437	C:FXD CER 5000 PF +80-20% 200VDCW	72982	2425-000-X5V-502P	7
0160-2438	C:FXD CER 5000 PF +80-20% 200VDCW	72982	2425-061-X5V0-502P	2
0170-0040	C:FXD MY .047 UF 10% 200VDCW	28480	0170-0040	1
0180-0049	C:FXD AL ELECT 20UF 50VDCW	56289	30D206G050DC6M1	2
0180-0058	C:FXD ELECT 50UF -10%+100% 25VDCW	56289	30D506G025DD4M1	2
0180-0061	C:FXD ELECT 100UF +100%-10% 15VDCW	56289	30107G015DD4	2
0180-0129	C:FXD ELECT 975UF -10+50% 40VDCW	56289	D35782	2
0180-0197	C:FXD ELECT 2.2 UF 10% 20VDCW	56289	150D225X9020A2	1
0180-0374	C:FXD ELECT 10 UF 10% 20VDCW	28480	0180-0374	1
0180-0376	C:FXD ELECT 0.47 UF 10% 35VDCW	56289	150D474X9035A2	1
0180-1735	C:FXD ELECT 0.22 UF 10% 35VDCW	28480	0180-1735	1
0340-0008	INSULATOR:STANDOFF TEFLON	98291	ST-1000-L2	1
0360-0040	TERMINAL:SOLDER LUG	73734	1958	2
0360-0042	TERMINAL:SOLDER LUG FOR #6 SCREW	28480	0360-0042	1
0360-0124	TERMINAL:SOLDER LUG	28480	0360-0124	4
0380-0336	STANDOFF	28480	0380-0336	1
0410-0159	CRYSTAL:QUARTZ 20MHZ	28480	0410-0159	1
0590-0012	NUT:KNURLED 15/32-32	04009	899U-3	1
0698-0083	R:FXD MET FLM 1.96K OHM 1% 1/8W	28480	0698-0083	7
0698-0084	R:FXD MET FLM 2.15K OHM 1% 1/8W	28480	0698-0084	3
0698-3136	R:FXD MET FLM 17.8K OHM 1% 1/8W	28480	0698-3136	3
0698-3151	R:FXD MET FLM 2.87K OHM 1% 1/8W	28480	0698-3151	2
0698-3153	R:FXD MET FLM 3.83K OHM 1% 1/8W	28480	0698-3153	5
0698-3154	R:FXD MET FLM 4.22K OHM 1% 1/8W	28480	0698-3154	5
0698-3155	R:FXD MET FLM 4.64K OHM 1% 1/8W	28480	0698-3155	2
0698-3156	R:FXD MET FLM 14.7K OHM 1% 1/8W	28480	0698-3156	3
0698-3157	R:FXD MET FLM 19.6K OHM 1% 1/8W	28480	0698-3157	1
0698-3159	R:FXD MET FLM 26.1K OHM 1% 1/8W	28480	0698-3159	2
0698-3160	R:FXD MET FLM 31.6K OHM 1% 1/8W	28480	0698-3160	1
0698-3260	R:FXD MET FLM 464K OHM 1% 1/8W	28480	0698-3260	1
0698-3438	R:FXD MET FLM 147 OHM 1% 1/8W	28480	0698-3438	2
0698-3440	R:FXD MET FLM 10% OHM 1% 1/8W	28480	0698-3440	5

www.valuetronics.com

See introduction to this section for ordering information

Table 6-2. Replaceable Parts (Cont.)

Part No.	Description #	Mfr.	Mfr. Part No.	TQ
0698-3443	R:FXD MET FLM 287 OHM 1% 1/8W	28480	0698-3443	3
0698-3444	R:FXD MET FLM 316 OHM 1% 1/8W	28480	0698-3444	3
0698-3445	R:FXD MET FLM 348 OHM 1% 1/8W	28480	0698-3445	1
0698-3446	R:FXD MET FLM 383 OHM 1% 1/8W	28480	0698-3446	3
0698-3449	R:FXD MET FLM 28.7K OHM 1% 1/8W	28480	0698-3449	1
0698-3450	R:FXD MET FLM 42.2K OHM 1% 1/8W	28480	0698-3450	2
0698-3451	R:FXD MET FLM 133K OHM 1% 1/8W	28480	0698-3451	1
0698-3453	R:FXD MET FLM 196K OHM 1% 1/8W	28480	0698-3453	2
0698-3629	R:FXD MET QX 270 OHM 5% 2W	28480	0698-3629	1
0757-0199	R:FXD MET FLM 21.5K OHM 1% 1/8W	28480	0757-0199	6
0757-0200	R:FXD MET FLM 5.62K OHM 1% 1/8W	28480	0757-0200	1
0757-0276	R:FXD MET FLM 61.9 OHM 1% 1/8W	28480	0757-0276	1
0757-0278	R:FXD MET FLM 1.78K OHM 1% 1/8W	28480	0757-0278	2
0757-0279	R:FXD MET FLM 3.16K OHM 1% 1/8W	28480	0757-0279	9
0757-0280	R:FXD MET FLM 1K OHM 1% 1/8W	28480	0757-0280	12
0757-0288	R:FXD MET FLM 9.09K OHM 1% 1/8W	28480	0757-0288	1
0757-0289	R:FXD MET FLM 13.3K OHM 1% 1/8W	28480	0757-0289	1
0757-0290	R:FXD MET FLM 6.19K OHM 1% 1/8W	28480	0757-0290	2
0757-0379	R:FXD MET FLM 12.1 OHM 1% 1/8W	28480	0757-0379	1
0757-0394	R:FXD MET FLM 51.1 OHM 1% 1/8W	28480	0757-0394	3
0757-0398	R:FXD MET FLM 75 OHM 1% 1/8W	28480	0757-0398	1
0757-0401	R:FXD MET FLM 100 OHM 1% 1/8W	28480	0757-0401	11
0757-0402	R:FXD MET FLM 110 OHM 1% 1/8W	28480	0757-0402	3
0757-0416	R:FXD MET FLM 511 OHM 1% 1/8W	28480	0757-0416	6
0757-0417	R:FXD MET FLM 562 OHM 1% 1/8W	28480	0757-0417	2
0757-0419	R:FXD MET FLM 681 OHM 1% 1/8W	28480	0757-0419	2
0757-0420	R:FXD MET FLM 750 OHM 1% 1/8W	28480	0757-0420	3
0757-0421	R:FXD MET FLM 825 OHM 1% 1/8W	28480	0757-0421	1
0757-0422	R:FXD MET FLM 909 OHM 1% 1/8W	28480	0757-0422	1
0757-0424	R:FXD MET FLM 1.10K OHM 1% 1/8W	28480	0757-0424	3
0757-0428	R:FXD MET FLM 1.62K OHM 1% 1/8W	28480	0757-0428	2
0757-0438	R:FXD MET FLM 5.11K OHM 1% 1/8W	28480	0757-0438	10
0757-0439	R:FXD MET FLM 6.81K OHM 1% 1/8W	28480	0757-0439	2
0757-0441	R:FXD MET FLM 8.25K OHM 1% 1/8W	28480	0757-0441	3
0757-0442	R:FXD MET FLM 10.0K OHM 1% 1/8W	28480	0757-0442	9
0757-0443	R:FXD MET FLM 11.0K OHM 1% 1/8W	28480	0757-0443	1
0757-0447	R:FXD MET FLM 16.2K OHM 1% 1/8W	28480	0757-0447	2
0757-0458	R:FXD MET FLM 51.1K OHM 1% 1/8W	28480	0757-0458	2
0757-0461	R:FXD MET FLM 68.1K OHM 1% 1/8W	28480	0757-0461	1
0757-0462	R:FXD MET FLM 75.0K OHM 1% 1/8W	28480	0757-0462	2
0757-0463	R:FXD MET FLM 82.5K OHM 1% 1/8W	28480	0757-0463	1
0757-0796	R:FXD MET FLM 82.5 OHM 1% 1/2W	28480	0757-0796	1
0757-1094	R:FXD MET FLM 1.47K OHM 1% 1/8W	28480	0757-1094	5
0811-1670	R:FXD WW 2.2 OHM 5% 2W	28480	0811-1670	2
0812-0086	R:FXD WW 5 OHM 5% 3W	28480	0812-0086	2
0900-0016	"O" RING:11/16"	28480	0900-0016	1
1120-1476	METER:500 UA	28480	1120-1476	1
1200-0063	LUG:CRIMP	28480	1200-0063	2
1200-0191	SOCKET:CRYSTAL	91506	8004-1G7	1
1250-0083	CONNECTOR:BNC	28480	1250-0083	4
1251-0159	CONNECTOR:2X15 CONTACT	28480	1251-0159	2
1251-0160	CONNECTOR:15 PIN	28480	1251-0160	4
1400-0084	FUSEHOLDER:EXTRACTOR POST TYPE	79515	342014	1
1410-0052	BUSHING:POTENTIOMETER	28480	1410-0052	1

See introduction to this section for ordering information

Table 6-2. Replaceable Parts (Cont.)

Part No.	Description #	Mfr.	Mfr. Part No.	TQ
1450-0152	LEN:LAMPHOLDER RED PLASTIC	08717	102XX-R	2
1450-0153	LAMPHOLDER:FOR T-1 SERIES	08717	102SR	2
1450-0157	LENS:LAMPHOLDER	08717	102XX-W	2
1460-0256	SPRING:COMPRESSION	28480	1460-0256	1
1820-0306	INTEGRATED CIRCUIT	28480	1820-0306	4
1853-0012	TRANSISTOR:PNP SILICON 2N2904A	04713	2N2904A	1
1853-0015	TRANSISTOR:SILICON PNP 2N3640	28480	1853-0015	1
1853-0016	TRANSISTOR:SILICON PNP 2N3638	07263	2N3638	4
1853-0020	TRANSISTOR:SILICON PNP	28480	1853-0020	8
1853-0036	TRANSISTOR:SILICON PNP	28480	1853-0036	2
1854-0039	TRANSISTOR:SILICON 2N3053	02735	2N3053	7
1854-0063	TRANSISTOR:NPN SILICON 2N3055	02735	2N3055	2
1854-0071	TRANSISTOR:SILICON NPN	28480	1854-0071	14
1854-0092	TRANSISTOR:SILICON NPN 2N3563	28480	1854-0092	6
1855-0078	TRANSISTOR:FIELD EFFECT 40 OHM 6V	28480	1855-0078	1
1901-0022	DIODE:SILICON 0.56V AT 1 MA	28480	1901-0022	2
1901-0025	DIODE:SILICON 100WV 100MA	28480	1901-0025	9
1901-0026	DIODE:SILICON 0.75A 200 PIV	28480	1901-0026	8
1901-0179	DIODE:SILICON 15WV	28480	1901-0179	8
1902-0049	DIODE,BREAKDOWN: 6.19V 5%	28480	1902-0049	2
1902-3048	DIODE BREAKDOWN:SILICON 3.48V 5%	28480	1902-3048	2
1902-3193	DIODE BREAKDOWN:13.3V 5%	28480	1902-3193	1
1910-0020	DIODE:GERMANIUM 1N55A	28480	1910-0020	2
1910-0022	DIODE:GERMANIUM 5 WIV	28480	1910-0022	1
2100-0467	R:VAR COMP 50K OHM 10% LIN 2.25W	28480	2100-0467	1
2100-0942	R:VAR MET FLM 50K OHM 20% TYPE V	28480	2100-0942	1
2100-1772	R:VAR WW 500 OHM 10% LIN 1/2W	28480	2100-1772	1
2110-0018	FUSE:CARTRIDGE 0.25 AMP SLOW BLOW	75915	313.250	1
2110-0064	FUSE:0.125A 125V SLO-BLO	28480	2110-0064	1
2140-0092	LAMP:5V 60 MA	28480	2140-0092	2
2190-0006	WASHER:SPLIT LOCK FOR #6 SCREW	80120	080	2
2190-0016	WASHER:LOCK PH BRZ NP	00000	080	1
2190-0037	WASHER:LOCK SST FOR 1/2 THREAD	78189	1224-08	1
2190-0058	WASHER:LOCK FOR #8 HDW	00000	080#	1
2190-0065	WASHER:LOCK FOR #6 HDW	28480	2190-0065	6
2190-0067	WASHER:LOCK FOR 1/4" HDW	28480	2190-0067	2
2190-0068	WASHER:LOCK PH BRZ NP 0.62X0.505X0.022	78189	1924-02	2
2190-0091	WASHER:LOCK FOR #10 HDW	28480	2190-0091	1
2190-0102	WASHER:LOCK PHOSPHOR BRONZE	28480	2190-0102	1
2190-0476	WASHER:LOCK FOR #4 HDW	00000	080#	1
2270-0004	SCREW:STL PHIL DR PAN HD 4-40	28480	2270-0004	1
2420-0003	NUT:HEX SST 6-32	80120	080#	2
2460-0013	SCREW:STL PHIL DR PAN HD 6-32	80120	080#	2
2460-0014	SCREW:STL PHIL DR PAN HD 6-32	28480	2460-0014	6
2515-0004	SCREW:STL PHIL DR PAN HD 8-32	00000	080#	1
2700-0002	SCREW:SST PHIL DR PAN HD 10-32	80120	080#	1
2740-0005	NUT:HEX STL 10-32	73734	080#	1
2950-0001	NUT:HEX BRS NP 3/8-32 X 1/2	73734	9002	2
2950-0034	NUT:HEX BRASS 3/8-32 X 1/2"	28480	2950-0034	1
2950-0035	NUT:HEX BRASS 15/32-32	00000	080#	1
2950-0038	NUT:HEX SST 1/2-24 X 11/16	75915	903-12	1
2950-0052	NUT:HEX BRASS 1/4-40	04009	080#	2
3101-0037	SWITCH:TOGGLE SPST	04009	83050-E	1
3101-0070	SWITCH:SLIDE	79727	G-126	1

www.valuetronics.com

See introduction to this section for ordering information

Table 6-2. Replaceable Parts (Cont.)

Part No.	Description #	Mfr.	Mfr. Part No.	TQ
3101-0903	SWITCH:SLIDE DP3T	79727	G-128-S	1
4040-0247	BEZEL:METER	28480	4040-0247	1
7120-1254	TRADEMARK	28480	7120-1254	1
9100-1614	COIL/CHOKE:0.82 UH 10%	28480	9100-1614	1
9100-1618	COIL:MOLDED CHOKE 5.60 UH	28480	9100-1618	1
9100-1621	COIL/CHOKE 18 UH 10%	28480	9100-1621	1
9100-1623	COIL/CHOKE 27 UH 5%	28480	9100-1623	1
9100-1625	COIL:MOLDED CHOKE 330 UH 5%	28480	9100-1625	2
9100-1631	COIL/CHOKE 56 UH 5%	28480	9100-1631	1
9100-2230	COIL/CHOKE:.15 UH 3%	82142	4415-1H	1
9100-2469	TRANSFORMER	28480	9100-2469	1
9140-0105	COIL:MOLDED CHOKE 8.20 UH 10%	28480	9140-0105	4
9140-0114	COIL:FXD RF 10 UH	28480	9140-0114	4
9140-0121	COIL:FXD 1.8 UH	28480	9140-0121	2
9140-0137	COIL:FXD RF 1 MH 5%	28480	9140-0137	1
08410-2006	BOARD:BLANK PC	28480	08410-2006	1
08410-2007	BOARD:BLANK PC	28480	08410-2007	1
08410-2009	BOARD:BLANK PC	28480	08410-2009	1
08410-2041	BOARD:BLANK PC	28480	08410-2041	1
08410-6007	SEARCH GENERATOR ASSY	28480	08410-6007	1
08709-0003	COVER:UPPER PC HOUSING	28480	08709-0003	1
08709-0004	COVER:LOWER PC HOUSING	28480	08709-0004	1
08709-2000	CASTING:PC HOUSING	28480	08709-2000	1
08709-2003	BOARD:BLANK PC	28480	08709-2003	1
08709-6001	PREAMPLIFIER ASSY	28480	08709-6001	1
08709-6002	AMPLIFIER ASSY	28480	08709-6002	1
08709-6003	POWER SUPPLY/AMPL ASSY	28480	08709-6003	1
08709-6004	LOCK MODE SWITCH ASSY	28480	08709-6004	1
08709-6005	CASTING ASSY(SHIELD)	28480	08709-6005	1
08709-6006	TRANSFORMER ASSY	28480	08709-6006	1
08709-6007	PHASE DETECTOR ASSY	28480	08709-6007	1
08709-6008	OSCILLATOR ASSY:20MHZ	28480	08709-6008	1
08709-6009-1	COIL:20MHZ,ADJ. 0.4-1.0 UH	28480	08706-6009-1	1

www.valuetronics.com

See introduction to this section for ordering information

Table 6-2. Replaceable Parts (Cont.)

Part No.	Description #	Mfr.	Mfr. Part No.	TQ
1490-0032	STAND:TILT HALF-MODULE	28480	1490-0032	1
2190-0179	WASHER:LOCK FOR #6 HDW	28480	2190-0179	2
2360-0069	SCREW:STL PHIL DR FLAT HD 6-32	28480	2360-0069	1
2370-0023	SCREW:SST PHIL DR FLAT HD 6-32	28480	2370-0023	1
2370-0035	SCREW:STL PHIL DR 6-32	00000	0BD#	1
2370-0047	SCREW:SST PHIL DR 6-32	28480	2370-0047	2
5000-0703	SIDE COVER	28480	5000-0703	1
5000-0717	COVER:HALF-MODULE BOTTOM	28480	5000-0717	1
5020-0701	CABINET SPACER	28480	5020-0701	1
5040-0700	HINGE	28480	5040-0700	1
5060-0703	FRAME ASSY:6 X 11 SM	28480	5060-0703	1
5060-0720	COVER:HALF-RECESS TOP	28480	5060-0720	1
5060-0728	FOOT ASSY:HALF MODULE	28480	5060-0728	1
08709-0001	REAR PANEL	28480	08709-0001	1
08709-0002	FRONT PANEL	28480	08709-0002	1

www.valuetronics.com

See introduction to this section for ordering information

TABLE 6-3.
CODE LIST OF MANUFACTURERS

The following code numbers are from the Federal Supply Code for Manufacturers Cataloging Handbooks H4-1 (Name to Code) and H4-2 (Code to Name) and their latest supplements. The date of revision and the date of the supplements used appear at the bottom of each page. Alphabetical codes have been arbitrarily assigned to suppliers not appearing in the H4 Handbooks.

Code No.	Manufacturer	Address	Code No.	Manufacturer	Address	Code No.	Manufacturer	Address
00000	U. S. A. Common	Any supplier of U. S.	05245	Components Corp.	Chicago, Ill.	09145	Tech. Ind. Inc. Atom Elect.	Burbank, Calif.
00136	McCoy Electronics	Mount Holly Springs, Pa.	05277	Westinghouse Electric Corp.		09250	Electro Assemblies, Inc.	Chicago, Ill.
00213	Sage Electronics Corp.	Rochester, N. Y.		Semi-Conductor Dept.	Youngwood, Pa.	09353	C & K Components Inc.	Newton, Mass.
00287	Mcenco Inc.	Danielson, Conn.	05347	Ultronix, Inc.	San Mateo, Calif.	09569	Mallory Battery Co. of	
00334	Humidial	Colton, Calif.	05397	Union Carbide Corp., Elect. Div.	New York, N. Y.		Canada, Ltd.	Toronto, Ontario, Canada
00348	Microtron Co., Inc.	Valley Stream, N. Y.	05574	Viking Ind. Inc.	Canoga Park, Calif.	09922	Burnly Corp.	Norwalk, Conn.
00373	Garlock Inc.	Cherry Hill, N. J.	05593	Icore Electro-Plastics Inc.	Sunnyvale, Calif.	10214	General Transistor Western Corp.	
00656	Aerovox Corp.	New Bedford, Mass.	05616	Cosmo Plastic				Los Angeles, Calif.
00779	Amp. Inc.	Harrisburg, Pa.		(c/o Electrical Spec. Co.)	Cleveland, Ohio	10411	Ti-Tal, Inc.	Berkeley, Calif.
00781	Aircraft Radio Corp.	Boonton, N. J.	05624	Barber Colman Co.	Rockford, Ill.	10646	Carborundum Co.	Niagara Falls, N. Y.
00815	Northern Engineering Laboratories, Inc.	Burlington, Wis.	05728	Tiffen Optical Co.		11236	CTS of Berne, Inc.	Berne, Ind.
00853	Saagamo Electric Co., Pickens Div.	Pickens, S. C.			Roslyn Heights, Long Island, N. Y.	11237	Chicago Telephone of California, Inc.	
00866	Goe Engineering Co.	City of Industry, Cal.	05729	Metro-Tel Corp.	Westbury, N. Y.	11242	Bay State Electronics Corp.	So. Pasadena, Calif.
00891	Carl E. Holmes Corp.	Los Angeles, Calif.	05783	Stewart Engineering Co.	Santa Cruz, Calif.	11312	Teledyne Inc., Microwave Div.	Palo Alto, Calif.
00929	Microlab Inc.	Livingston, N. J.	05820	Wakefield Engineering Inc.	Wakefield, Mass.	11314	National Seal	Downey, Calif.
01002	General Electric Co., Capacitor Dept.		06004	Bassick Co., Div. of Stewart Warner Corp.		11453	Precision Connector Corp.	Jamaica, N. Y.
01009	Alden Products Co.	Brockton, Mass.			Bridgeport, Conn.	11534	Duncan Electronics Inc.	Costa Mesa, Calif.
01121	Allen Bradley Co.	Milwaukee, Wis.	06090	Raychem Corp.	Redwood City, Calif.	11711	General Instrument Corp., Semiconductor	
01255	Litton Industries, Inc.	Beverly Hills, Calif.	06175	Bausch and Lomb Optical Co.	Rochester, N. Y.		Div., Products Group	Newark, N. J.
01281	TRW Semiconductors, Inc.	Lawndale, Calif.	06402	E. T. A. Products Co. of America	Chicago, Ill.	11717	Imperial Electronic, Inc.	Buena Park, Calif.
01295	Texas Instruments, Inc., Transistor Products Div.	Dallas, Texas	06540	Anatom Electronic Hardware Co., Inc.		11870	Melabs, Inc.	Palo Alto, Calif.
01349	The Alliance Mfg. Co.	Alliance, Ohio	06555	Beede Electrical Instrument Co., Inc.	New Rochelle, N. Y.	12040	National Semiconductor	Danbury, Conn.
01589	Pacific Relays, Inc.	Van Nuys, Calif.	06666	General Devices Co., Inc.	Peacock, N. H.	12136	Philadelphia Handle Co.	Camden, N. J.
01670	Gudebrod Bros. Silk Co.	New York, N. Y.	06751	Components Inc., Ariz. Div.	Indianapolis, Ind.	12361	Grove Mfg. Co., Inc.	Shady Grove, Pa.
01930	Amerock Corp.	Rockford, Ill.	06812	Torrington Mfg. Co., West Div.	Phoenix, Ariz.	12574	Gulton Ind. Inc. Data System Div.	
01961	Pulse Engineering Co.	Santa Clara, Calif.			Van Nuys, Calif.	12697	Clarostat Mfg. Co.	Albuquerque, N. M.
02114	Ferroxcube Corp. of America	Saugerties, N. Y.	06980	Varian Assoc. Eimac Div.	San Carlos, Calif.	12728	Elmar Filler Corp.	Dover, N. H.
02116	Wheelock Signals, Inc.	Long Branch, N. J.	07088	Kelvia Electric Co.	Van Nuys, Calif.	12859	Nippon Electric Co., Ltd.	Tokyo, Japan
02286	Cole Rubber and Plastics Inc.	Sunnyvale, Calif.	07126	Digitran Co.	Pasadena, Calif.	12881	Metex Electronics Corp.	Clark, N. J.
02660	Amphenol-Borg Electronics Corp.	Broadview, Ill.	07137	Transistor Electronics Corp.	Minneapolis, Minn.	12930	Delta Semiconductor Inc.	Newport Beach, Calif.
02735	Radio Corp. of America, Semiconductor and Materials Div.	Somerville, N. J.	07138	Westinghouse Electric Corp. Electronic Tube Div.		12954	Dickson Electronics Corp.	Scottsdale, Arizona
02771	Vocaline Co. of America, Inc.		07149	Filmohm Corp.	Elmira, N. Y.	13103	Thermolloy	Dallas, Texas
		Old Saybrook, Conn.	07233	Cinch-Graphik Co.	New York, N. Y.	13396	Telefunken (GmbH)	Hanover, Germany
02777	Hopkins Engineering Co.	San Fernando, Calif.	07256	Silicon Transistor Corp.	City of Industry, Calif.	13835	Midland-Wright Div. of Pacific Industries, Inc.	
02875	Hudson Tool & Die Co.	Newark, N. J.	07261	Avnet Corp.	Carle Place, N. Y.			Kansas City, Kansas
03508	G. E. Semiconductor Prod. Dept.	Syracuse, N. Y.	07263	Fairchild Camera & Inst. Corp. Semiconductor Div.	Culver City, Calif.	14099	Sem-Tech	Newbury Park, Calif.
03705	Apex Machine & Tool Co.	Dayton, Ohio	07322	Minnesota Rubber Co.	Mountain View, Calif.	14193	Calif. Resistor Corp.	Santa Monica, Calif.
03797	Eldema Corp.	Compton, Calif.	07387	Birchler Corp., The	Minneapolis, Minn.	14298	American Components, Inc.	Conshohocken, Pa.
03818	Parker Seal Co.	Los Angeles, Calif.	07397	Sylvania Elect. Prod. Inc., Mt. View Operations	Mountain View, Calif.	14433	ITT Semiconductor, A Div. of Int. Telephone & Telegraph Corp.	West Palm Beach, Fla.
03877	Transitron Electric Corp.	Wakefield, Mass.			Minneapolis, Minn.	14493	Hewlett-Packard Company	Loveland, Colo.
03888	Pyrofilm Resistor Co., Inc.	Cedar Knolls, N. J.	07700	Technical Wire Products Inc.	Monterey Park, Calif.	14655	Cornell Dublier Electric Corp.	Newark, N. J.
03954	Singer Co., Diehl Div.		07829	Bodine Elect. Co.	Mt. View Operations	14674	Corning Glass Works	Corning, N. Y.
	Finderne Plant	Somerville, N. J.	07910	Continental Device Corp.	Mountain View, Calif.	14752	Electro Cube Inc.	San Gabriel, Calif.
04009	Arrow, Hart and Hegeman Elect. Co.		07933	Raytheon Mfg. Co., Semiconductor Div.	Cranford, N. J.	14960	Williams Mfg. Co.	San Jose, Calif.
		Hartford, Conn.	07980	Hewlett-Packard Co., Boonton Radio Div.	Chicago, Ill.	15203	Webster Electronics Co.	New York, N. Y.
04013	Taurus Corp.	Lambertville, N. J.			Hawthorne, Calif.	15287	Scionics Corp.	Northridge, Calif.
04062	Arco Electronic Inc.	Great Neck, N. Y.	08145	U. S. Engineering Co.	Mountain View, Calif.	15291	Adjustable Bushing Co.	N. Hollywood, Calif.
04222	Hi-Q Division of Aerovox	Myrtle Beach, S. C.	08289	Blinn, Delbert Co.	Boonton Radio Div.	15558	Micron Electronics	
04354	Precision Paper Tube Co.	Wheeling, Ill.	08358	Burgess Battery Co.	Rockaway, N. J.			Garden City, Long Island, N. Y.
04404	Dymec Division of Hewlett-Packard Co.				Los Angeles, Calif.	15566	Amprobe Inst. Corp.	Lynbrook, N. Y.
		Palo Alto, Calif.	08524	Deutsch Fastener Corp.	Pomona, Calif.	15631	Cabletronics	Costa Mesa, Calif.
04651	Sylvania Electric Products, Microwave Device Div.	Mountain View, Calif.			Niagara Falls, Ontario, Canada	15772	Twentieth Century Coil Spring Co.	
04673	Dakota Engr. Inc.	Culver City, Calif.	08664	Bristol Co., The				Santa Clara, Calif.
04713	Motorola, Inc., Semiconductor Prod. Div.	Phoenix, Arizona	08717	Sloan Company	Los Angeles, Calif.	15801	Fenwal Elect. Inc.	Framingham, Mass.
			08718	ITT Cannon Electric Inc., Phoenix Div.	Waterbury, Conn.	15818	Amelco Inc.	Mt. View, Calif.
04732	Filttron Co., Inc. Western Div.	Culver City, Calif.			Sun Valley, Calif.	16037	Spruce Pine Mica Co.	Spruce Pine, N. C.
			08727	National Radio Lab. Inc.	Phoenix, Arizona	16179	Omni-Spectra Inc.	Farmington, Mich.
04773	Automatic Electric Co.	Northlake, Ill.	08792	CBS Electronics Semiconductor Operations, Div. of C. B. S. Inc.	Paramus, N. J.	16352	Computer Diode Corp.	Lodi, N. J.
04796	Sequoia Wire Co.	Redwood City, Calif.				16585	Boots Aircraft Nut Corp.	Pasadena, Calif.
04811	Precision Coil Spring Co.	El Monte, Calif.	08806	General Electric Co. Miniat. Lamp Dept.		16688	Ideal Prec. Meter Co., Inc. De Jur Meter Div.	Brooklyn, N. Y.
04870	P. M. Motor Company	Westchester, Ill.			Lowell, Mass.	16758	Delco Radio Div. of G. M. Corp.	Kokoma, Ind.
04919	Component Mfg. Service Co.		08984	Mel-Rain	Cleveland, Ohio	17109	Thermonetics Inc.	Canoga Park, Calif.
		W. Bridgewater, Mass.	09026	Babcock Relays Div.	Indianapolis, Ind.	17474	Tranex Company	Mountain View, Calif.
05006	Twentieth Century Plastics, Inc.	Los Angeles, Calif.	09134	Texas Capacitor Co.	Costa Mesa, Calif.	17554	Components Inc.	Biddeford, Me.
					Houston, Texas	17675	Hamlin Metal Products Corp.	Akron, Ohio
						17745	Angstrom Prec. Inc.	No. Hollywood, Calif.

www.valuetronics.com

TABLE 6-3.
CODE LIST OF MANUFACTURERS (Continued)

Code No.	Manufacturer	Address	Code No.	Manufacturer	Address	Code No.	Manufacturer	Address
17870	McGraw-Edison Co.	Manchester, N. H.	62119	Universal Electric Co.	Owosso, Mich.	73899	JFD Electronics Corp.	Brooklyn, N. Y.
18042	Power Design Pacific Inc.	Palo Alto, Calif.	63743	Ward-Leonard Electric Co.	Mt. Vernon, N. Y.	73905	Jennings Radio Mfg. Corp.	San Jose, Calif.
18083	Clevite Corp., Semiconductor Div.	Palo Alto, Calif.	64959	Western Electric Co., Inc.	New York, N. Y.	73957	Groov-Pin Corp.	Ridgefield, N. J.
18324	Signetics Corp.	Palo Alto, Calif.	65092	Weston Inst. Inc. Weston-Newark	Newark, N. J.	74276	Signalite Inc.	Neptune, N. J.
18476	Ty-Car Mfg. Co., Inc.	Sunnyvale, Calif.	66295	Wittek Mfg. Co.	Chicago, Ill.	74455	J. H. Winns, and Sons	Winchester, Mass.
18486	TRW Elect. Comp. Div.	Holliston, Mass.	66346	Minnesota Mining & Mfg. Co. Revere Mincom Div.	St. Paul, Minn.	74861	Industrial Condenser Corp.	Chicago, Ill.
18583	Curtis Instrument, Inc.	Des Plaines, Ill.	70276	Allen Mfg. Co.	Hartford, Conn.	74868	R. F. Products Division of Amphenol-Borg Electronics Corp.	Danbury, Conn.
18612	Vishay Instruments Inc.	Malvern, Pa.	70309	Allied Control	New York, N. Y.	74970	E. F. Johnson Co.	Waseca, Minn.
18873	E. I. DuPont and Co., Inc.	Wilmington, Del.	70318	Allmetal Screw Product Co., Inc.	Garden City, N. Y.	75042	International Resistance Co.	Philadelphia, Pa.
18911	Durant Mfg. Co.	Milwaukee, Wis.	70417	Amplex, Div. of Chrysler Corp.	Detroit, Mich.	75263	Keystone Carbon Co., Inc.	St. Marys, Pa.
19315	The Bendix Corp., Navigation & Control Div.	Teterboro, N. J.	70485	Atlantic India Rubber Works, Inc.	Chicago, Ill.	75378	CTS Knights Inc.	Sandwich, Ill.
19500	Thomas A. Edison Industries, Div. of McGraw-Edison Co.	West Orange, N. J.	70563	Ampelite Co., Inc.	Union City, N. J.	75382	Kulka Electric Corporation	Mt. Vernon, N. Y.
19589	Concoa	Baldwin Park, Calif.	70574	ADC Products Inc.	Minneapolis, Minn.	75818	Lenz Electric Mfg. Co.	Chicago, Ill.
19644	LRC Electronics	Horseheads, N. Y.	70903	Belden Mfg. Co.	Chicago, Ill.	75915	Littlefuse, Inc.	Des Plaines, Ill.
19701	Electra Mfg. Co.	Independence, Kansas	70998	Bird Electronic Corp.	Cleveland, Ohio	76005	Lord Mfg. Co.	Erie, Pa.
20183	General Altronics Corp.	Philadelphia, Pa.	71002	Birenbach Radio Co.	New York, N. Y.	76210	C. W. Marwedel	San Francisco, Calif.
21226	Execulone, Inc.	Long Island City, N. Y.	71034	Bliley Electric Co., Inc.	Erie, Pa.	76433	General Instrument Corp., Micamold Division	Newark, N. J.
21335	Falmer Bearing Co., The	New Britain, Conn.	71041	Boston Gear Works Div. of Murray Co. of Texas	Quincy, Mass.	76487	James Millen Mfg. Co., Inc.	Malden, Mass.
21520	Fansteel Metallurgical Corp.	N. Chicago, Ill.	71218	Bud Radio, Inc.	Willoughby, Ohio	76493	J. W. Miller Co.	Los Angeles, Calif.
23042	Texscan Corp.	Indianapolis, Ind.	71279	Cambridge Thermionics Corp.	Cambridge, Mass.	76530	Cinch-Monadnock, Div. of United Carr Fastener Corp.	San Leandro, Calif.
23783	British Radio Electronics Ltd.	Washington, D. C.	71286	Camloc Fastener Corp.	Paramus, N. J.	76545	Mueller Electric Co.	Cleveland, Ohio
24455	G. E. Lamp Division	Nela Park, Cleveland, Ohio	71313	Cardwell Condenser Corp.	Lindenhurst L. I., N. Y.	76703	National Union	Newark, N. J.
24655	General Radio Co.	West Concord, Mass.	71400	Bussmann Mfg. Div. of McGraw-Edison Co.	St. Louis, Mo.	76854	Oak Manufacturing Co.	Crystal Lake, Ill.
24681	Memcor Inc., Comp. Div.	Huntington, Ind.	71436	Chicago Condenser Corp.	Chicago, Ill.	77088	The Bendix Corp., Electrodynamics Div.	N. Hollywood, Calif.
24796	Parelo Inc.	San Juan Capistrano, Calif.	71447	Calif. Spring Co., Inc.	Pico-Rivera, Calif.	77075	Pacific Metals Co.	San Francisco, Calif.
26365	Gries Reproducer Corp.	New Rochelle, N. Y.	71450	CTS Corp.	Elkhart, Ind.	77221	Phanostran Instrument and Electronic Co.	South Pasadena, Calif.
26462	Grobet Fife Co. of America, Inc.	Carlstadt, N. J.	71468	ITT Cannon Electric Inc.	Los Angeles, Calif.	77252	Philadelphia Steel and Wire Corp.	Philadelphia, Pa.
26851	Compac/Hollister Co.	Hollister, Calif.	71471	Cinema, Div. Aerovox Corp.	Burbank, Calif.	77342	American Machine & Foundry Co. Potter & Brumfield Div.	Princeton, Ind.
26992	Hamilton Watch Co.	Lancaster, Pa.	71482	C. P. Clare & Co.	Chicago, Ill.	77630	TRW Electronic Components Div.	Camden, N. J.
27251	Specialties Mfg. Co., Inc.	Stratford, Conn.	71590	Centralab Div. of Globe Union Inc.	Milwaukee, Wis.	77638	General Instrument Corp., Rectifier Div.	Brooklyn, N. Y.
28480	Hewlett-Packard Co.	Palo Alto, Calif.	71616	Commercial Plastics Co.	Chicago, Ill.	77764	Resistance Products Co.	Harrisburg, Pa.
28520	Heyman Mfg. Co.	Kenilworth, N. J.	71700	Cornish Wire Co., The	New York, N. Y.	77969	Rubbercraft Corp. of Calif.	Torrance, Calif.
30817	Instrument Specialties Co., Inc.	Little Falls, N. J.	71707	Coto Coil Co., Inc.	Providence, R. I.	78189	Shakeproof Division of Illinois Tool Works	Elgin, Ill.
33173	G. E. Receiving Tube Dept.	Owensboro, Ky.	71744	Chicago Miniature Lamp Works	Chicago, Ill.	78277	Sigma	So. Braintree, Mass.
35434	Lectrohm Inc.	Chicago, Ill.	71785	Cinch Mfg. Co., Howard B. Jones Div.	Chicago, Ill.	78283	Signal Indicator Corp.	New York, N. Y.
36196	Stanwyck Coil Products Ltd.	Hawkesbury, Ontario, Canada	71984	Dow Corning Corp.	Midland, Mich.	78290	Struthers-Dunn Inc.	Pitman, N. J.
36287	Cunningham, W. H. & Hill, Ltd.	Toronto Ontario, Canada	72136	Electro Molyve Mfg. Co., Inc.	Williamantic, Conn.	78424	Speciality Leather Prod. Co.	Newark, N. J.
37942	P. R. Mallory & Co. Inc.	Indianapolis, Ind.	72619	Dialight Corp.	Brooklyn, N. Y.	78452	Thompson-Bremer & Co.	Chicago, Ill.
39543	Mechanical Industries Prod. Co.	Akron, Ohio	72656	Indiana General Corp., Electronics Div.	Keasby, N. J.	78471	Tilley Mfg. Co.	San Francisco, Calif.
40920	Miniature Precision Bearings, Inc.	Keene, N. H.	72699	General Instrument Corp., Cap. Div.	Newark, N. J.	78488	Stackpole Carbon Co.	St. Marys, Pa.
42190	Muler Co.	Chicago, Ill.	72765	Drake Mfg. Co.	Harwood Heights, Ill.	78493	Standard Thomson Corp.	Waltham, Mass.
43990	C. A. Norgren Co.	Englewood, Colo.	72825	Hugh H. Eby Inc.	Philadelphia, Pa.	78553	Tinaerman Products, Inc.	Cleveland, Ohio
44655	Ohmite Mfg. Co.	Skokie, Ill.	72928	Gudeman Co.	Chicago, Ill.	78790	Transformer Engineers	San Gabriel, Calif.
46384	Penn Eng. & Mfg. Corp.	Doylesstown, Pa.	72962	Elastic Stop Nut Corp.	Union, N. J.	78947	Ucrnite Co.	Newtonville, Mass.
47904	Polaroid Corp.	Cambridge, Mass.	72964	Robert M. Hadley Co.	Los Angeles, Calif.	79136	Waides Kohnoor Inc.	Long Island City, N. Y.
48620	Precision Thermometer & Inst. Co.	Southampton, Pa.	72982	Erie Technological Products, Inc.	Erie, Pa.	79142	Veeder Root, Inc.	Hartford, Conn.
49956	Microwave & Power Tube Div.	Waltham, Mass.	73061	Hansen Mfg. Co., Inc.	Princeton, Ind.	79251	Wenco Mfg. Co.	Chicago, Ill.
52090	Rowan Controller Co.	Westminster, Md.	73076	H. M. Haiper Co.	Chicago, Ill.	79727	Continental-Wirt Electronics Corp.	Philadelphia, Pa.
52963	Samborn Company	Waltham, Mass.	73138	Helipot Div. of Beckman Inst., Inc.	Fullerton, Calif.	79963	Zierick Mfg. Corp.	New Rochelle, N. Y.
54294	Shallcross Mfg. Co.	Selma, N. C.	73293	Hughes Products Division of Hughes Aircraft Co.	Newport Beach, Calif.	80031	Mepro Division of Sessions Clock Co.	Morrisstown, N. J.
55026	Simpson Electric Co.	Chicago, Ill.	73445	Amperelect Co.	Hicksville, L. I., N. Y.	80120	Schnitzer Alloy Products Co.	Elizabeth, N. J.
55933	Sonotone Corp.	Elmsford, N. Y.	73506	Bradley Semiconductor Corp.	New Haven, Conn.	80131	Electronic Industries Association, Any brand Tube meeting EIA Standards-Washington, DC.	Washington, DC.
55938	Raytheon Co. Commercial Apparatus & Systems Div.	So. Norwalk, Conn.	73559	Carling Electric, Inc.	Hartford, Conn.	80207	Unimax Switch, Div. Maxon Electronics Corp.	Wallingford, Conn.
56137	Spaulding Fibre Co., Inc.	Tonawanda, N. Y.	73586	Circle F Mfg. Co.	Trenton, N. J.	80223	United Transformer Corp.	New York, N. Y.
56289	Sprague Electric Co.	North Adams, Mass.	73682	George K. Garrett Co., Div. MSL Industries Inc.	Philadelphia, Pa.	80248	Oxford Electric Corp.	Chicago, Ill.
59446	Telex Corp.	Tulsa, Okla.	73734	Federal Screw Products Inc.	Chicago, Ill.	80294	Bourin Inc.	Riverside, Calif.
59730	Thomas & Betts Co.	Elizabeth, N. J.	73743	Fischer Special Mfg. Co.	Cincinnati, Ohio	80411	Acro Div. of Robertshaw Controls Co.	Columbus, Ohio
60741	Triplet Electrical Inst. Co.	Bluffton, Ohio	73793	General Industries Co., The	Elyria, Ohio			
61775	Union Switch and Signal, Div. of Westinghouse Air Brake Co.	Pittsburgh, Pa.	73846	Goshen Stamping & Tool Co.	Goshen, Ind.			

SECTION VII SCHEMATIC DIAGRAMS

7-1. INTRODUCTION.

7-2. Schematic presentations in this manual show electrical circuit operation and are not intended to serve as wiring diagrams. Figures 7-1 and 7-2 list notes which apply to the schematic diagrams.

7-3. Some switch and circuit board assemblies are shown in part on different pages. To find a specific instrument component, refer to the "REFERENCE DESIGNATIONS" box which appears on each schematic diagram. Reference designations within assemblies are abbreviated. The full designation includes the assembly on which the component is mounted, and the individual component designation. For example, resistor R1 mounted on assembly A1 has the complete

reference designation of A1R1. Certain parts are not included on assemblies, and are classified as chassis parts. Chassis parts are assigned only the reference designation shown on the schematic diagram.

7-4. This section also contains information on component and test point locations within the instrument.

7-5. An asterisk indicates a factory selected part; the component value shown is the typical or most commonly selected value.

7-6. Component procurement information and specific component descriptions are included in Section VI. Refer to page 6-1 for information on how to order parts.

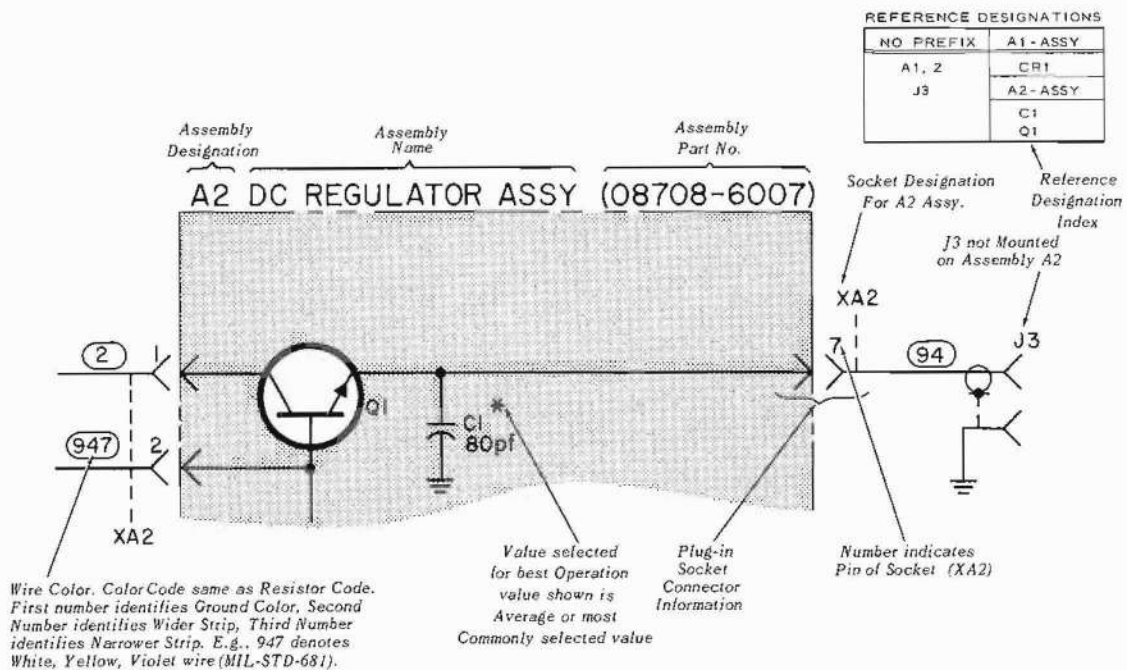

www.valuetronics.com

Figure 7-1. General Information on Schematic Diagrams

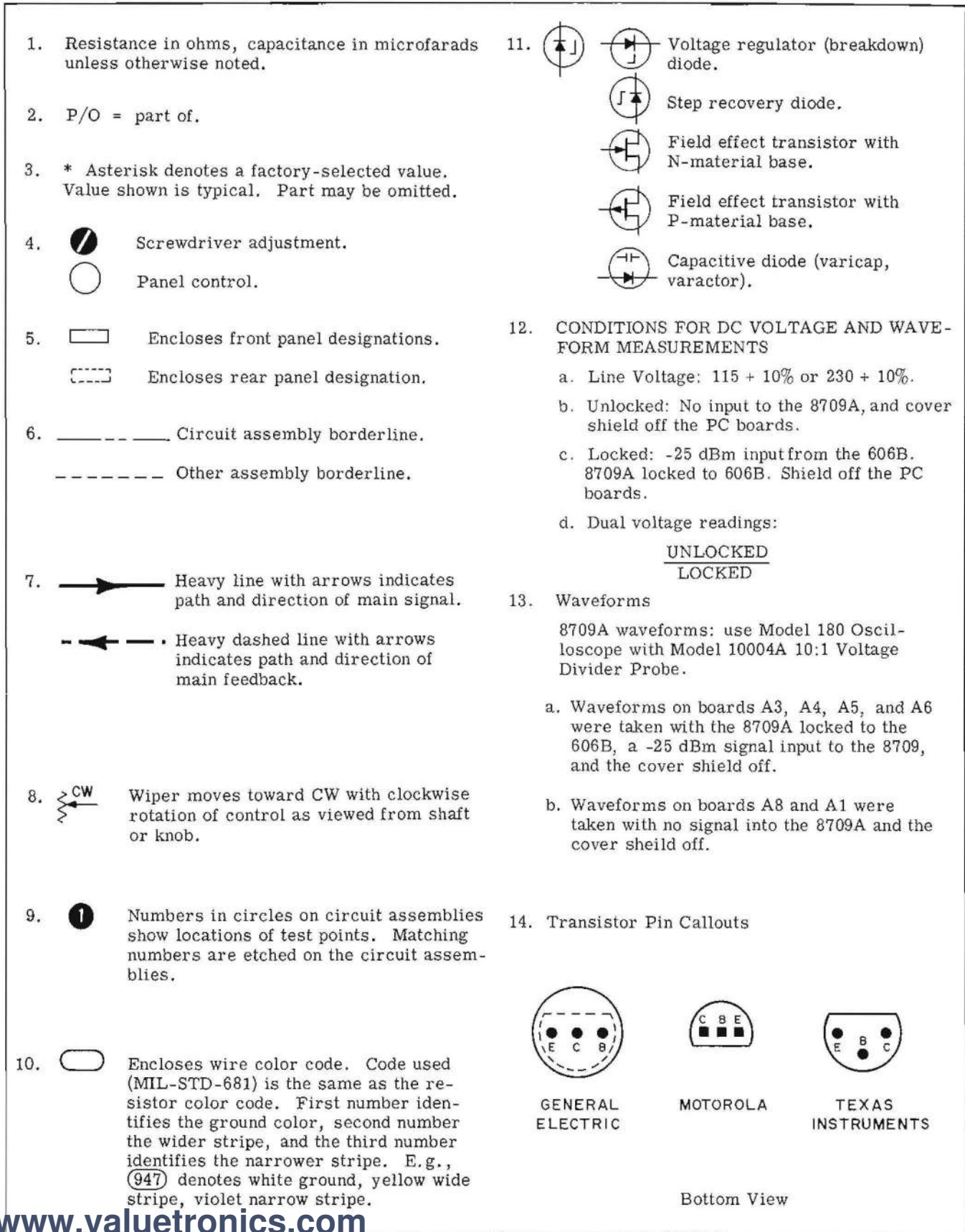
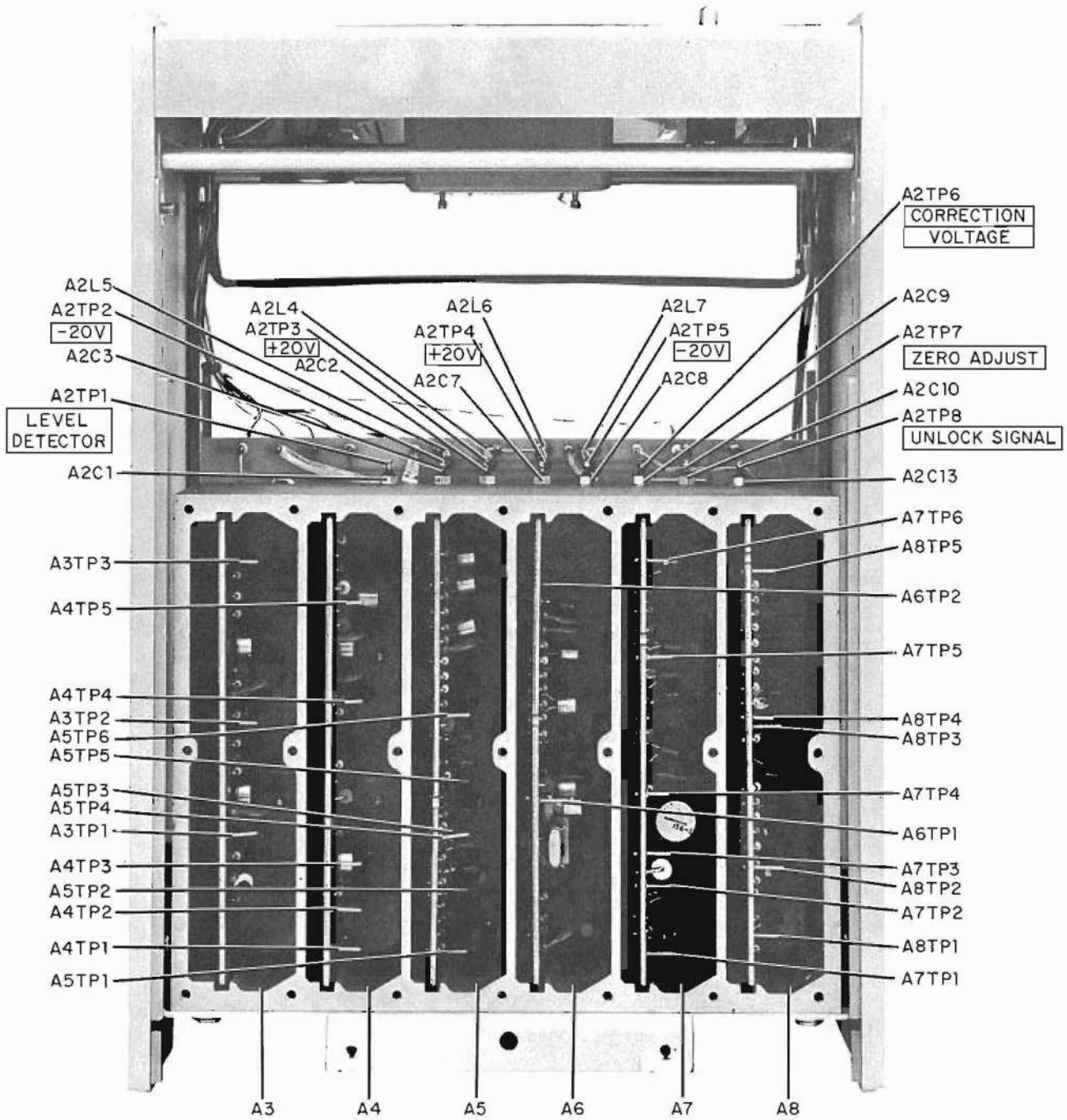

Figure 7-2. Schematic Diagram Notes



.Figure 7-3. Component and Parts Location, Interior Bottom View, A2 Casting

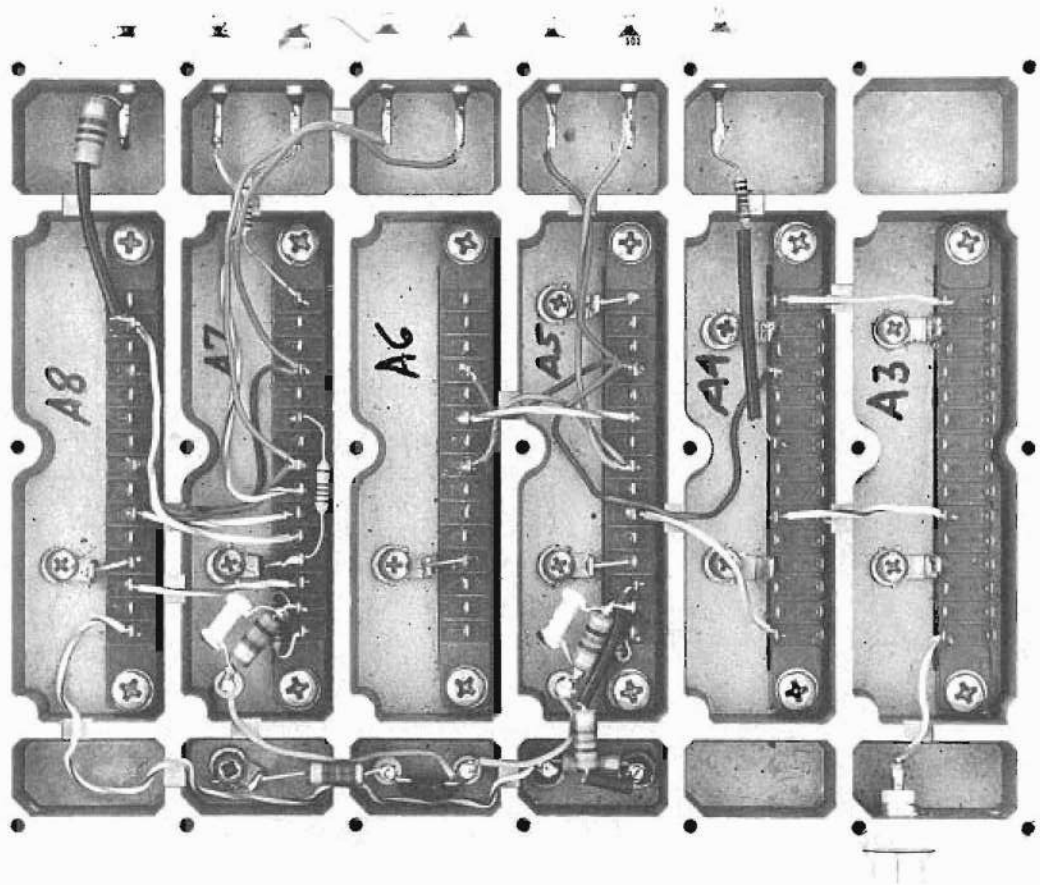

Figure 7-4a. Subchassis Component and Parts Location, A2 Casting

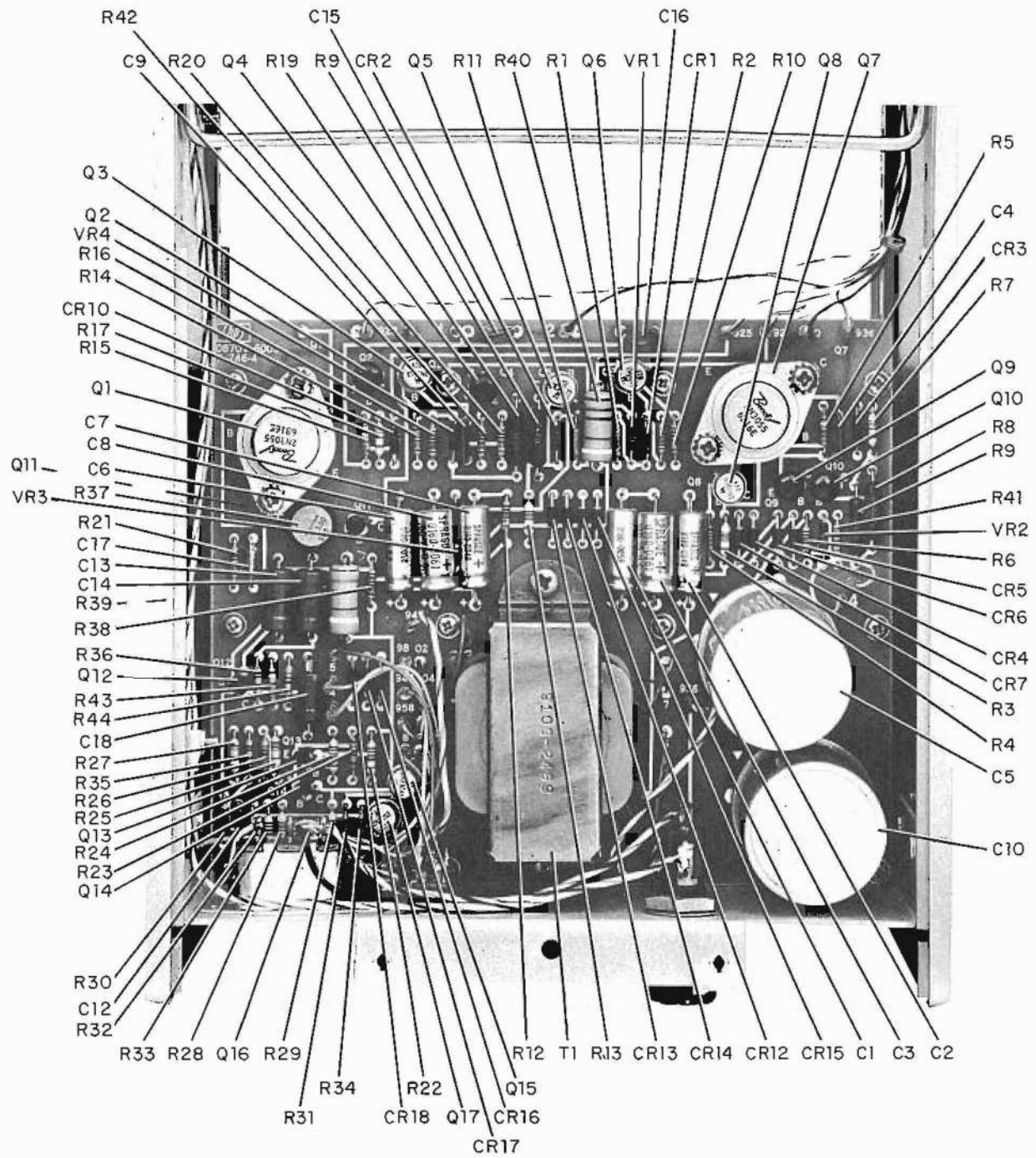

Figure 7-5a. A1 Power Supply/Amplifier Board Assembly Power Supply Component Identification and Location

www.valuetronics.com

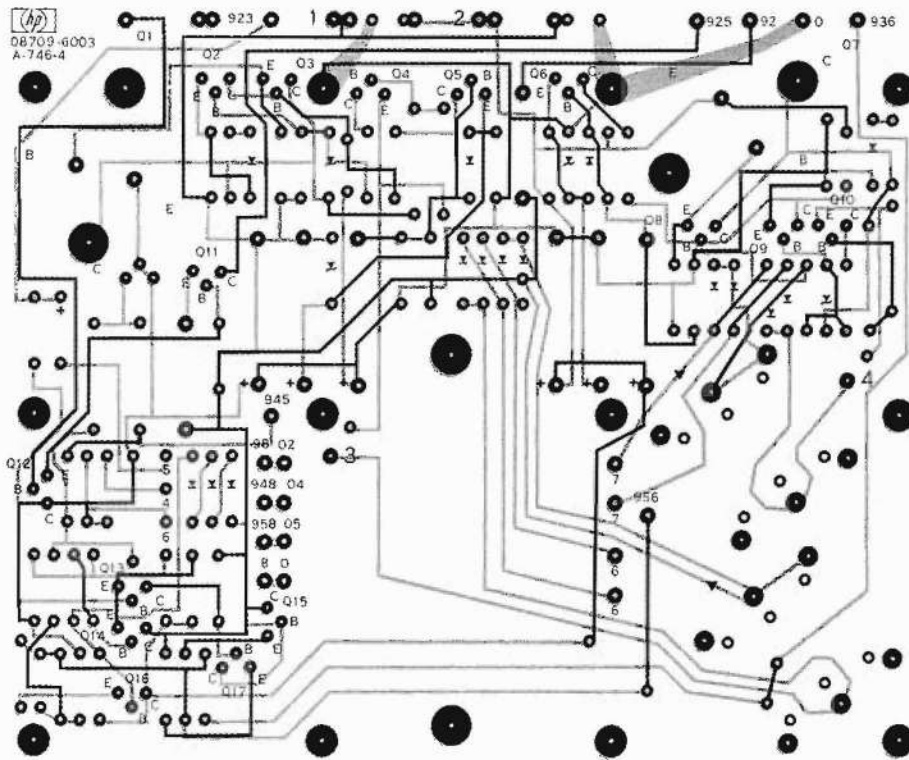

Figure 7-5b. A1 Power Supply/Amplifier Board Assembly
Circuit Paths and Solder Pads

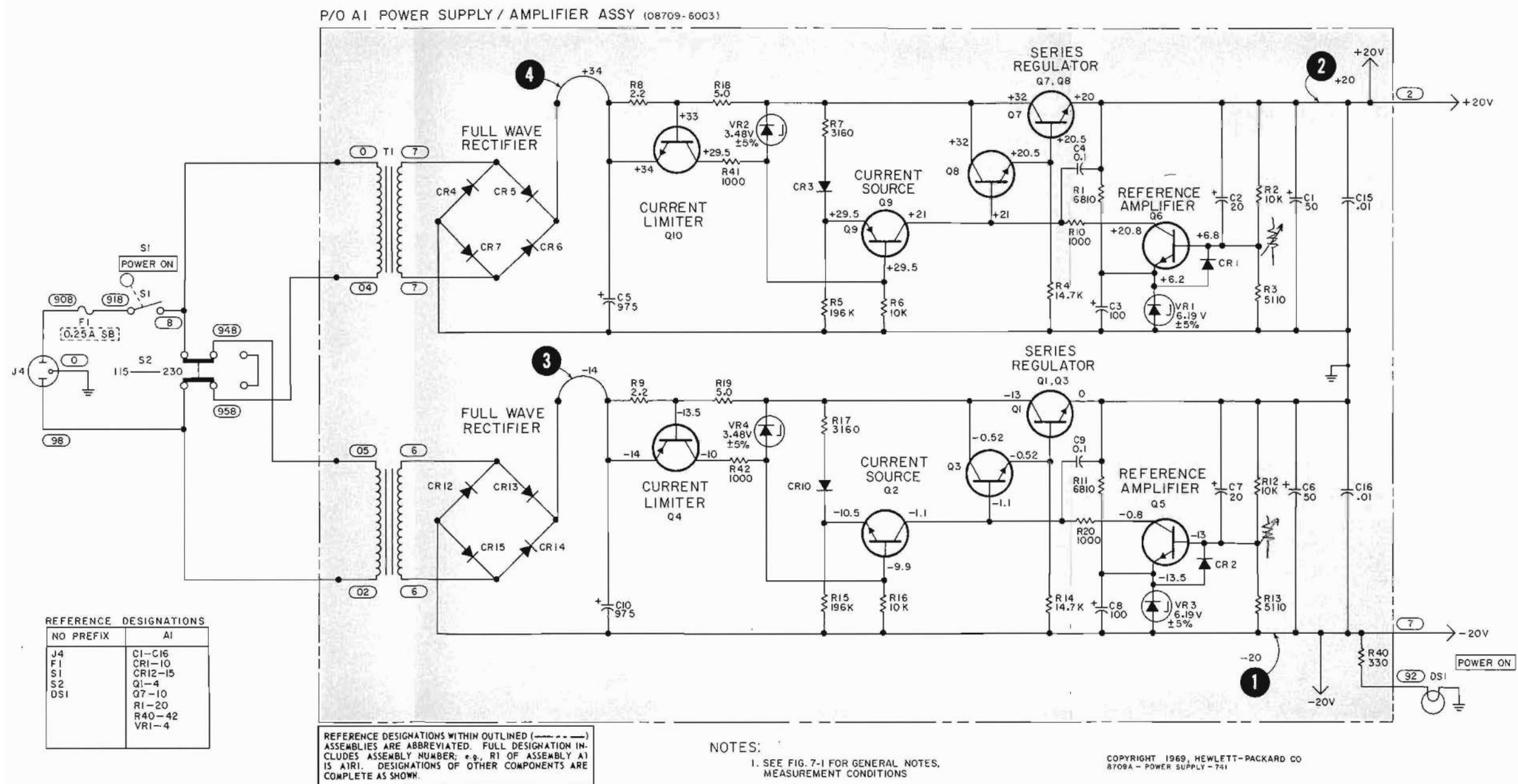

Figure 7-5c. A1 Power Supply/Amplifier Board Assembly Power Supply Schematic, 8709A

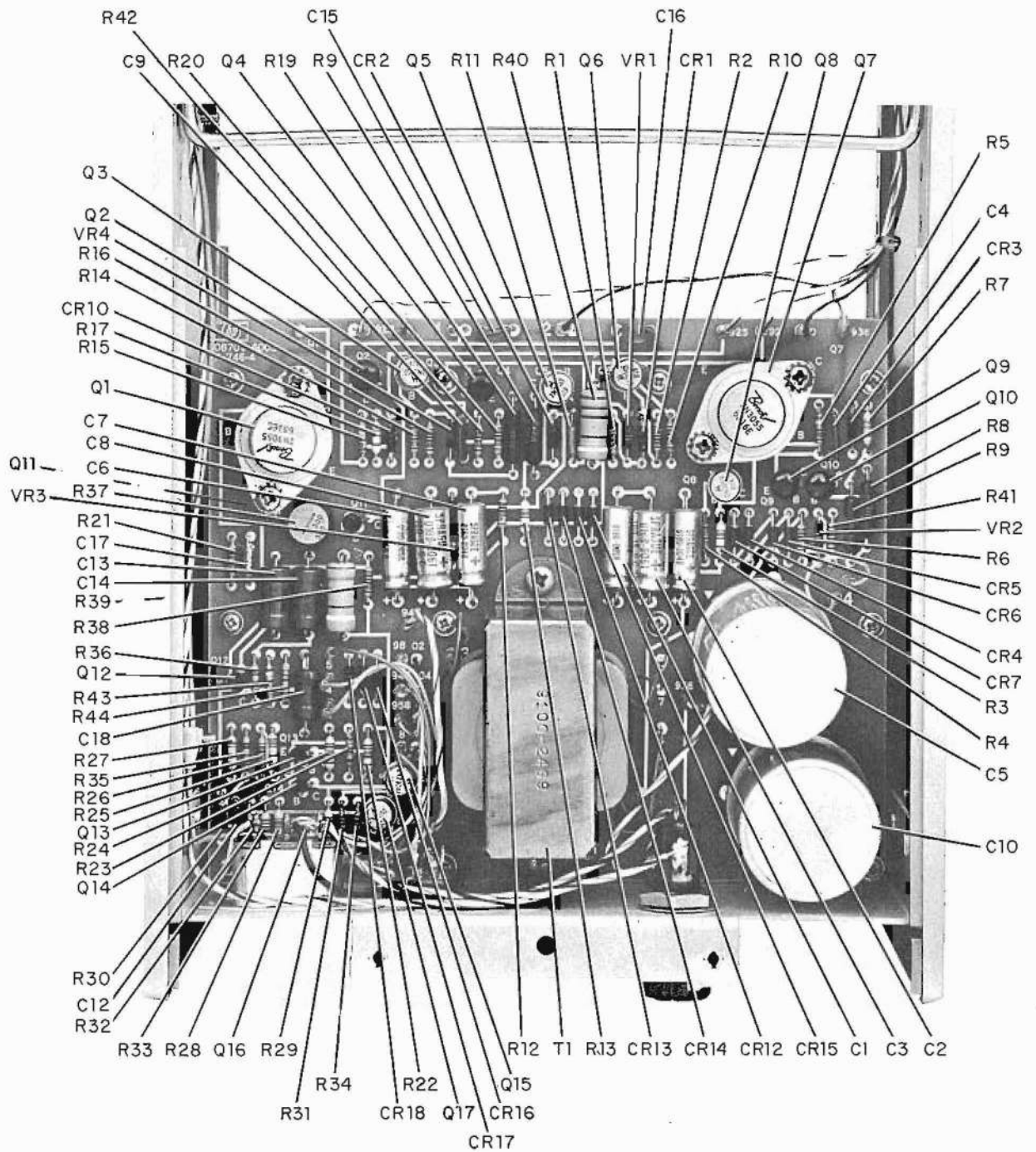

Figure 7-6a. A1 Power Supply/Amplifier Board Assembly Output Amplifier and Light Amplifier Component Identification and Location

www.valuetronics.com

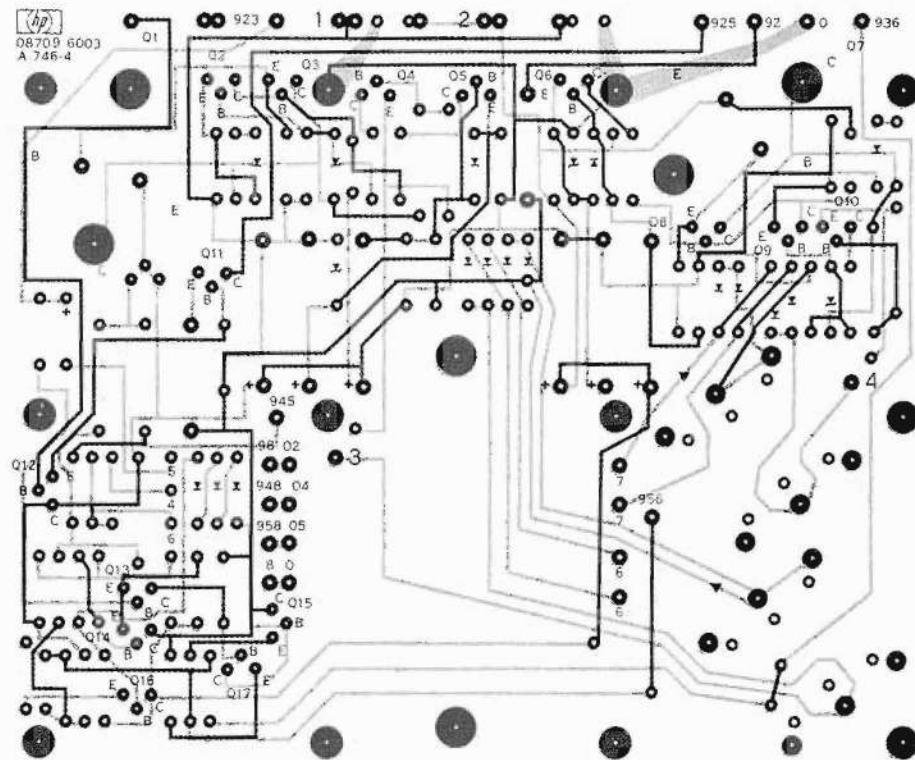
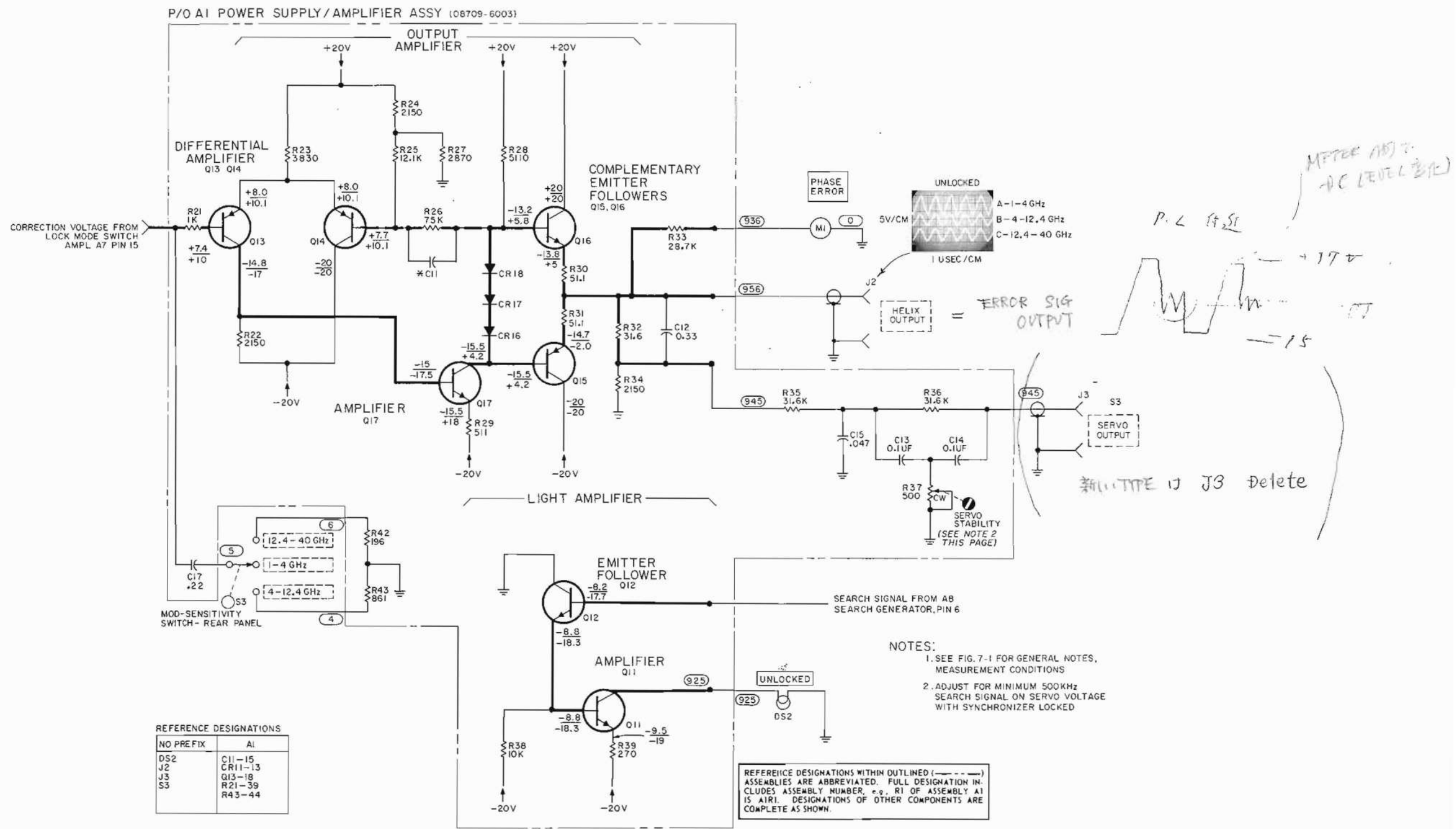

Figure 7-6b. A1 Power Supply/Amplifier Board Assembly Output Amplifier and Light Amplifier Circuit Paths and Solder Pads



COPYRIGHT 1969 HEWLETT-PACKARD CO
8709A - POWER SUPPLY/AMPLIFIER - 741

Figure 7-6c. A1 Power Supply/Amplifier Board Assembly Output Amplifier and Light Amplifier Schematic, 8709A



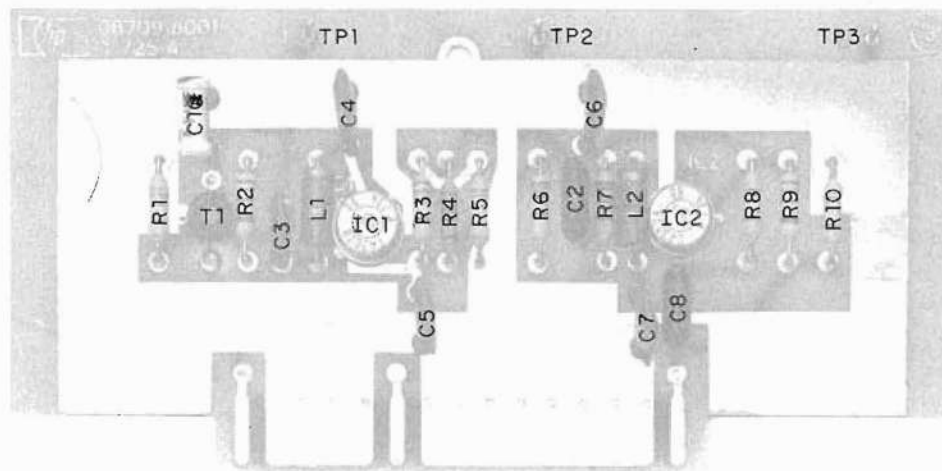
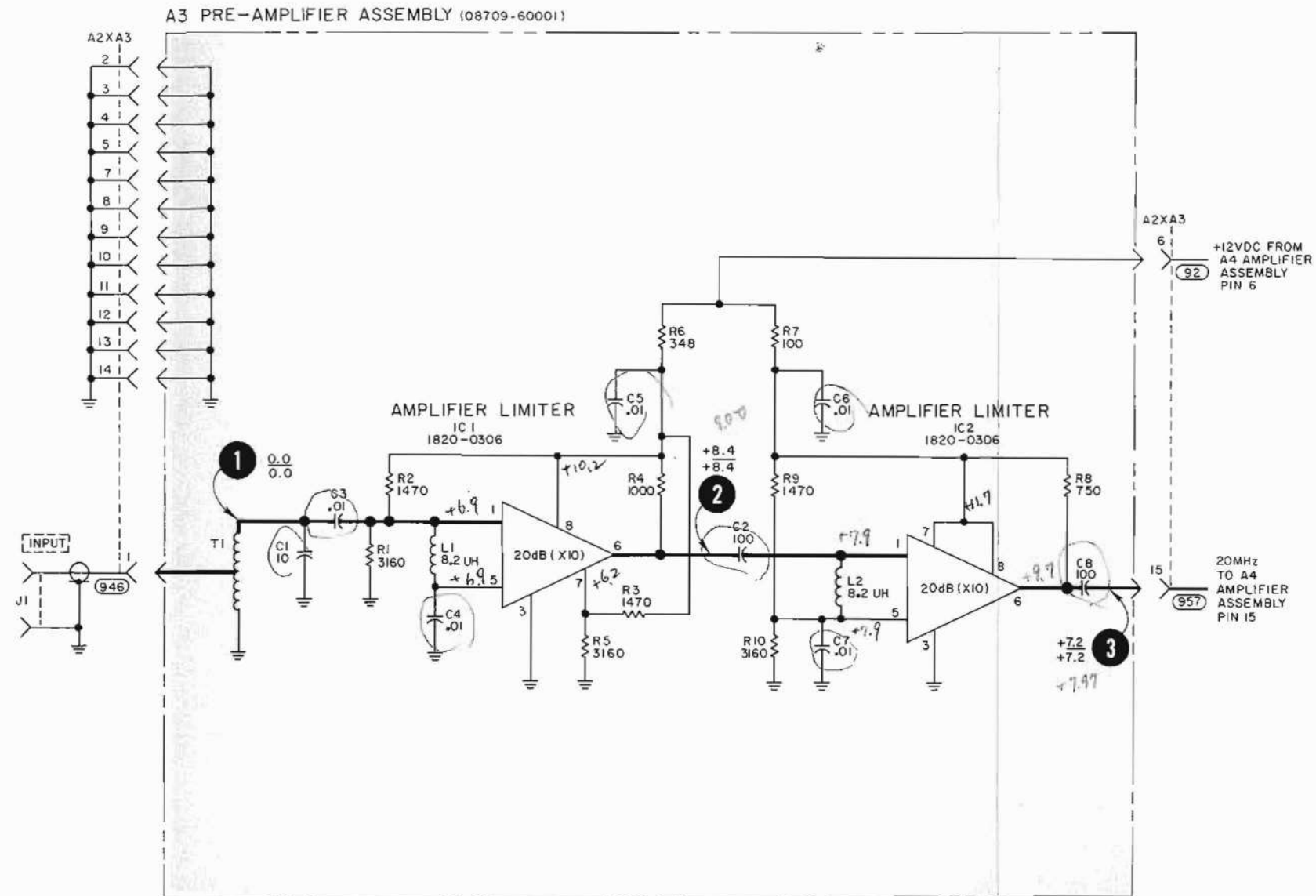

Figure 7-7a. A3 Preamplifier Board Assembly Component Identification and Location



COPYRIGHT 1969 BY HEWLETT-PACKARD CO.
8709A A3 PREAMP ASSY-741

NOTES:
1. SEE FIG.7-1 FOR GENERAL NOTES, MEASUREMENT CONDITIONS

REFERENCE DESIGNATIONS WITHIN OUTLINED (---) ASSEMBLIES ARE ABBREVIATED. FULL DESIGNATION INCLUDES ASSEMBLY NUMBER; e.g., R1 OF ASSEMBLY A1 IS A1R1. DESIGNATIONS OF OTHER COMPONENTS ARE COMPLETE AS SHOWN.

REFERENCE DESIGNATIONS

NO PREFIX	A3
J1	C1 IC1, 2 L1, 2 R1-10

Figure 7-7b. A3 Preamplifier Board Assembly Input Amplifier and Limiter Schematic, 8709A



Figure 7-6

**A1 POWER SUPPLY/AMPLIFIER BOARD
ASSEMBLY OUTPUT AMPLIFIER AND
LIGHT AMPLIFIER
SCHEMATIC, 8709A**

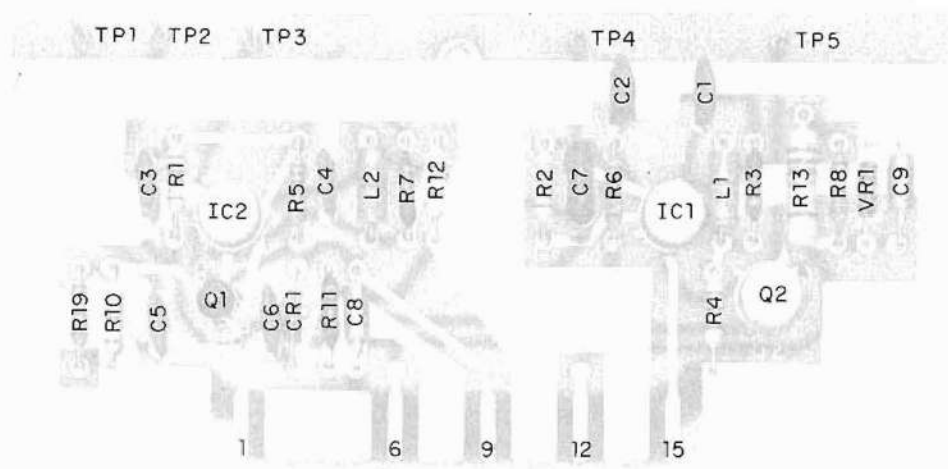

Figure 7-8a. A4 Amplifier Board Assembly Component Identification and Location

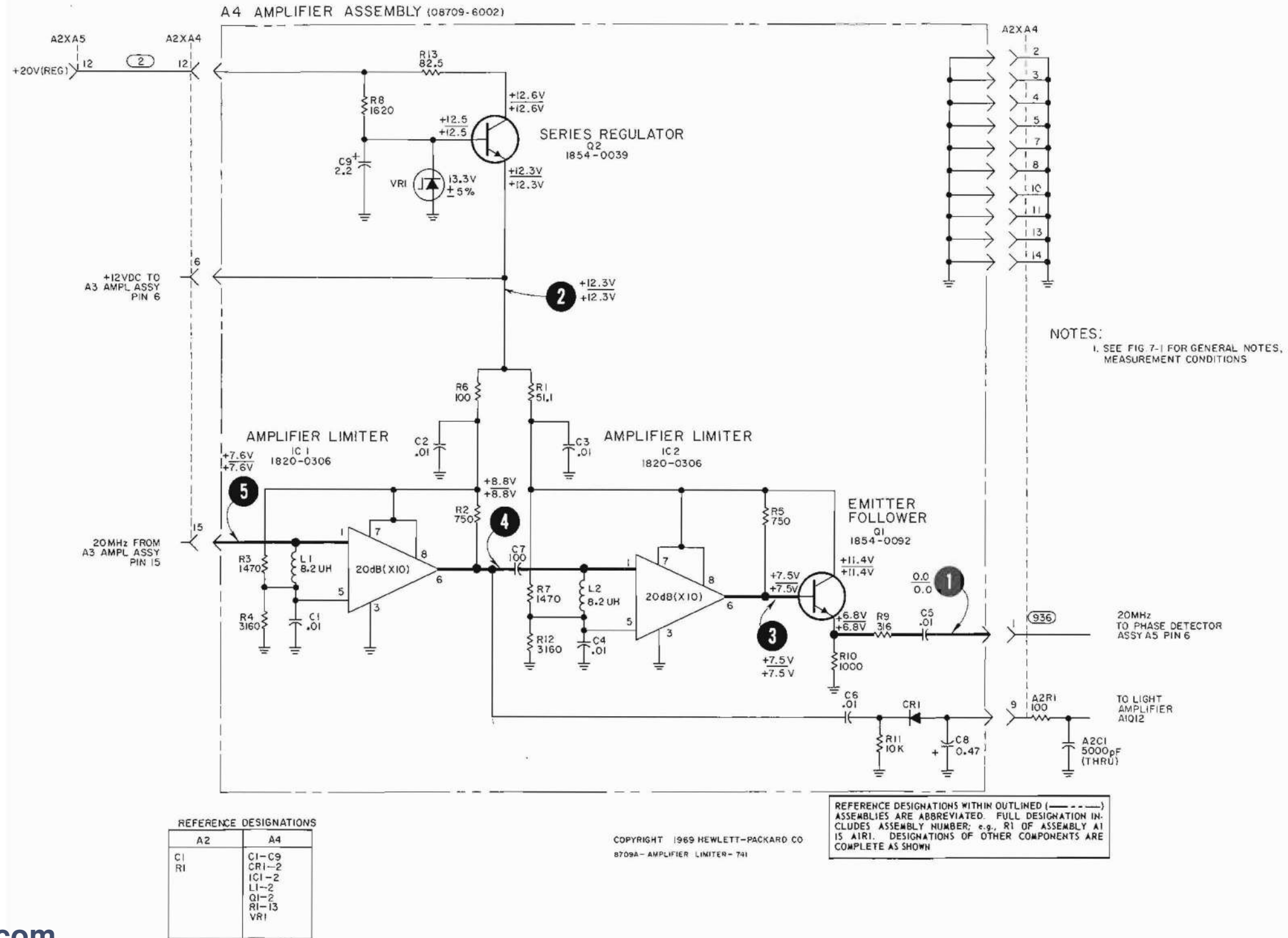

Figure 7-8b. A4 Amplifier Board Assembly Limiter Schematic, 8709A



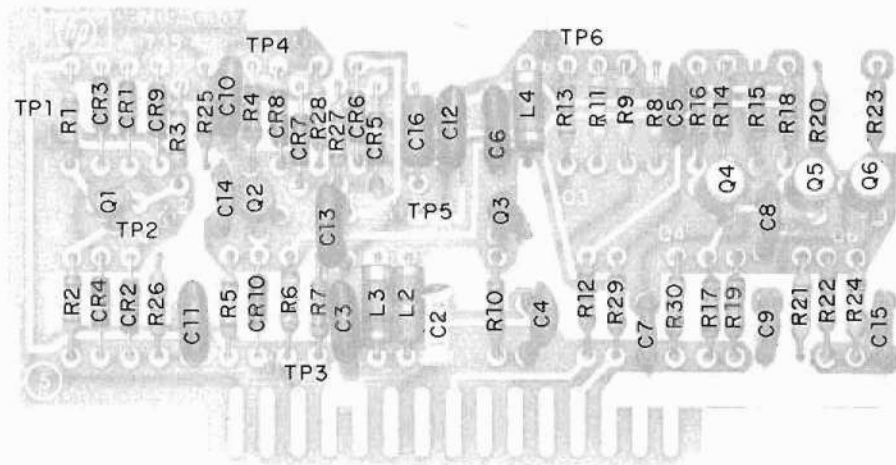

Figure 7-9a. A5 Phase Detector Board Assembly
Component Identification and Location

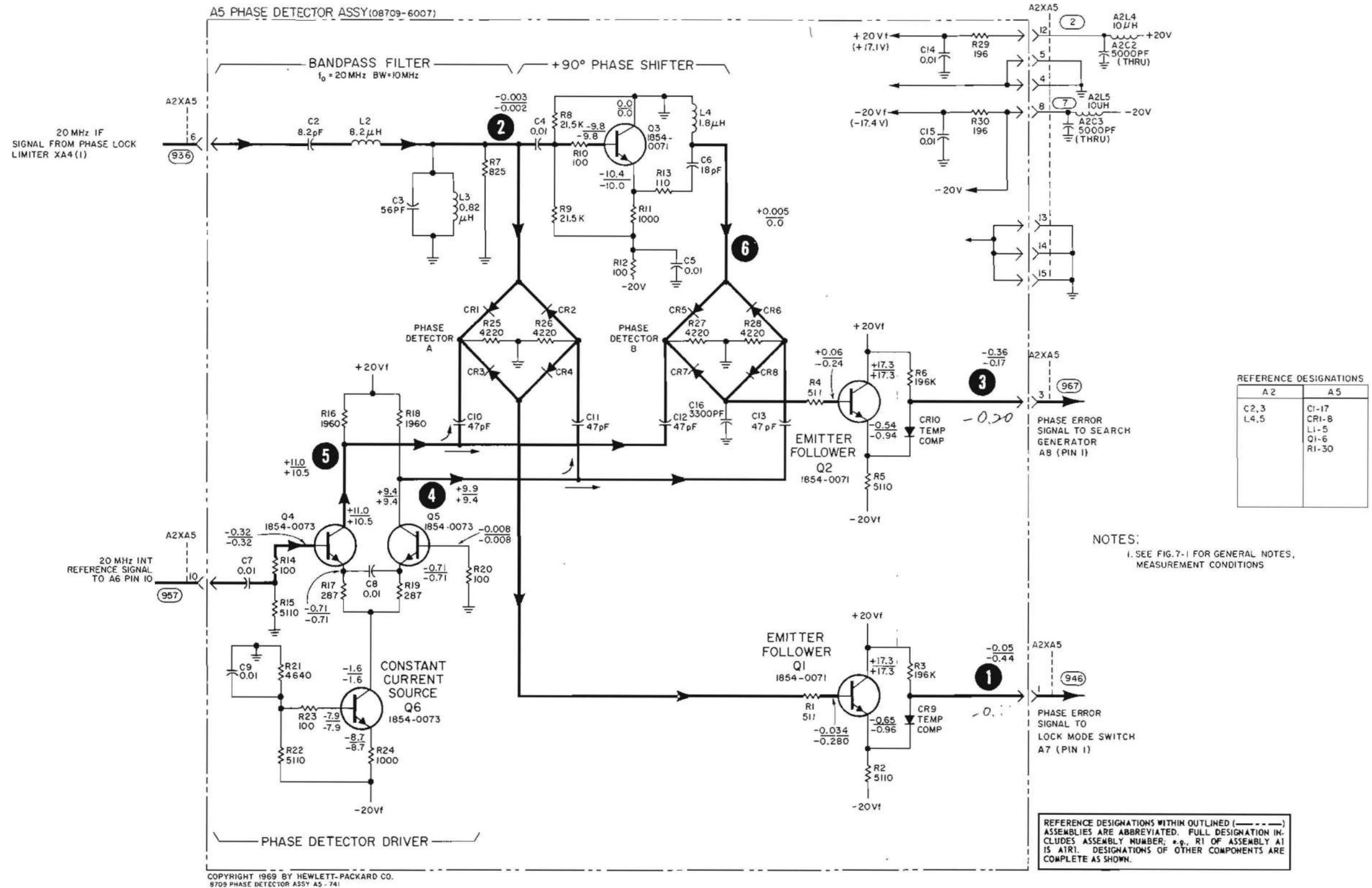

Figure 7-9b. A5 Phase Detector Board Assembly Schematic, 8709A



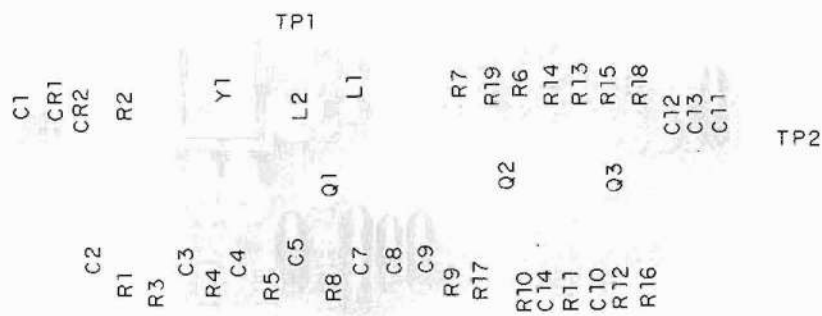

Figure 7-10a. A6 20 MHz Oscillator Board Assembly
Component Identification and Location

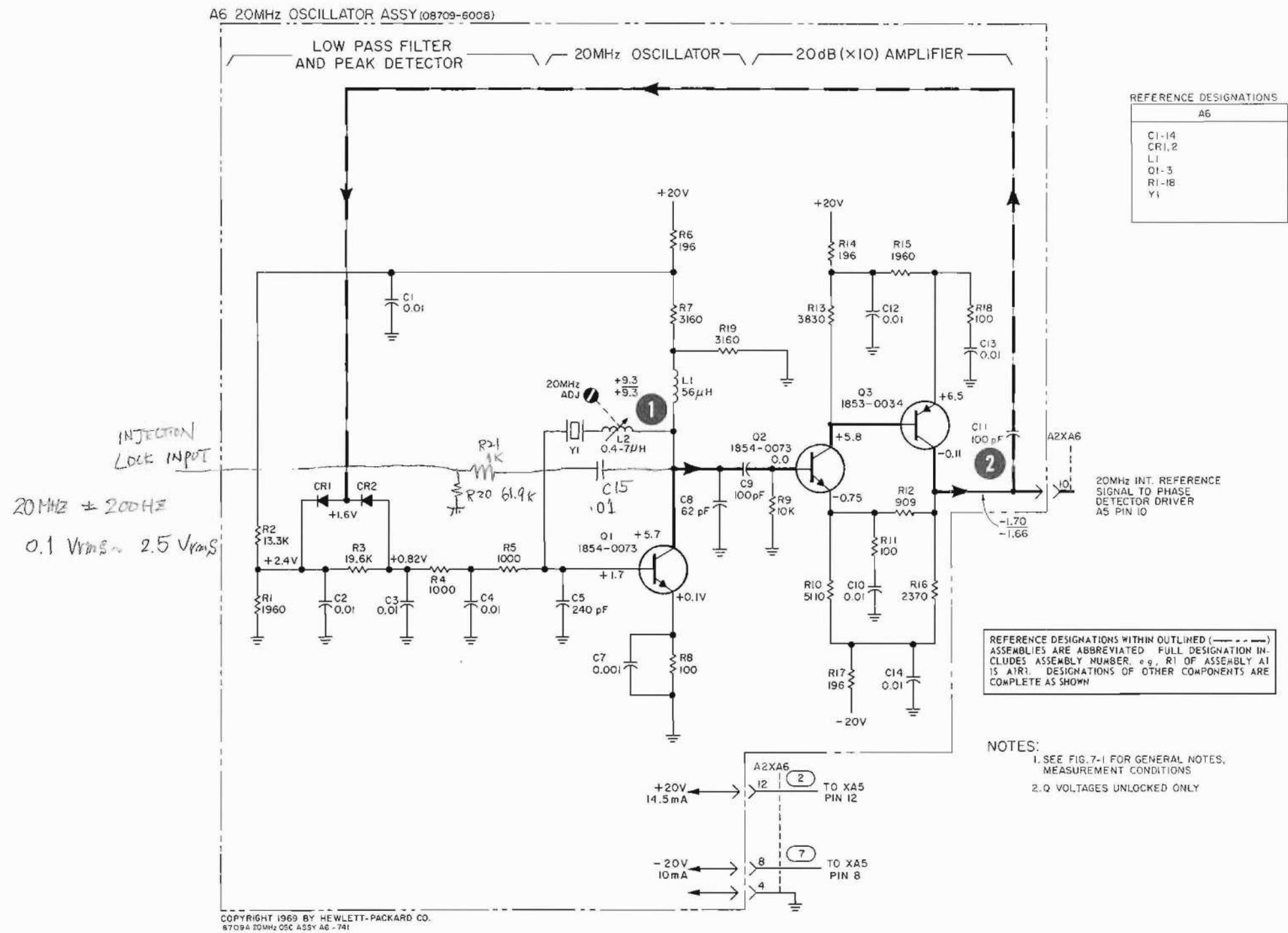

Figure 7-10b. A6 20 MHz Oscillator Board Assembly Schematic, 8709A



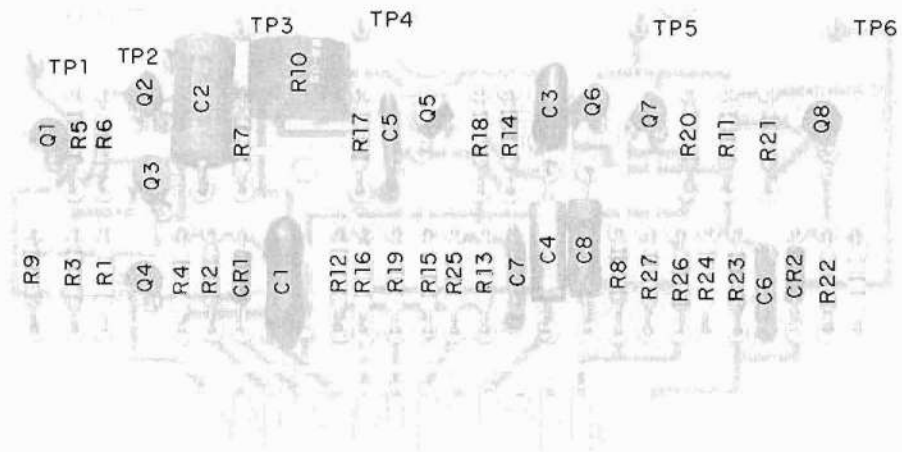
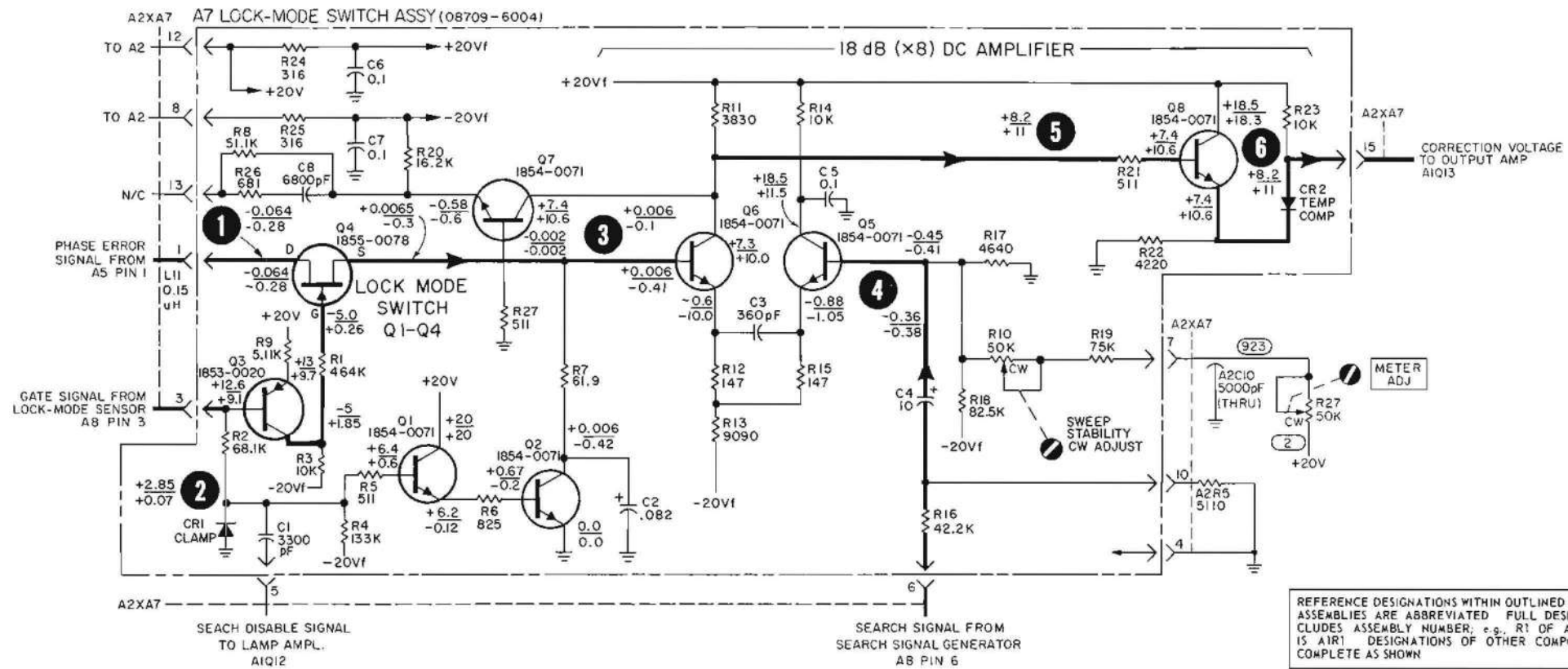

Figure 7-11a. A7 Lock-Mode Switch Board Assembly
Component Identification and Location



COPYRIGHT 1969 BY HEWLETT-PACKARD CO.
8709A LOCK-MODE ASSY A7 - 741

NOTES:

1. SEE FIG. 7-1 FOR GENERAL NOTES,
MEASUREMENT CONDITIONS.

REFERENCE DESIGNATIONS WITHIN OUTLINED (---) ASSEMBLIES ARE ABBREVIATED. FULL DESIGNATION INCLUDES ASSEMBLY NUMBER; e.g., R1 OF ASSEMBLY A1 IS A1R1. DESIGNATIONS OF OTHER COMPONENTS ARE COMPLETE AS SHOWN.

REFERENCE DESIGNATIONS

A2	A7	NO PREFIX
C10 R5	C1-8 C1 Q1-8 R1-26	R27



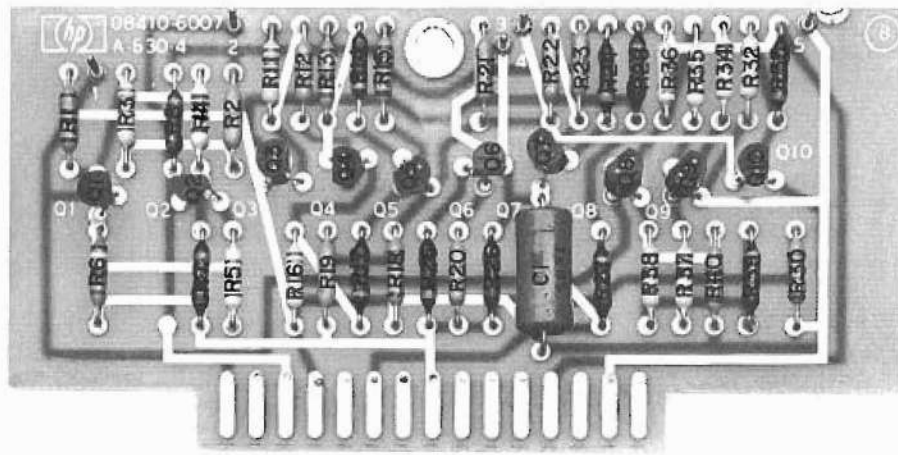

Figure 7-12a. A8 Search Generator Board Assembly
Component Identification and Location



SALES & SERVICE OFFICES

AFRICA, ASIA, AUSTRALIA

ANGOLA
Telectra
Empresa Técnica de Equipamentos Eléctricos, S.A.R.L.
R. Barbosa Rodrigues, 42-FDT
Cana Postal, 6487
Luanda
Tel: 3551516
Cable: TELECTRA Luanda

AUSTRALIA
Hewlett-Packard Australia Pty. Ltd.
31-41 Joseph Street
Blackburn, Victoria 3130
P.O. Box 36
Doncaster East, Victoria 3109
Tel: 89-9351
Telex: 31-024
Cable: HEWPARD Melbourne
Hewlett-Packard Australia Pty. Ltd.
31 Bridge Street
Pymble
New South Wales, 2073
Tel: 49-8586
Telex: 21561
Cable: HEWPARD Sydney
Hewlett-Packard Australia Pty. Ltd.
153 Greenhill Road
Parkside, S.A., 5063
Tel: 272-5911
Telex: 82536 ADEL
Cable: HEWPARD ADELAIDE
Hewlett-Packard Australia Pty. Ltd.
141 Stirling Highway
Nedlands, W.A. 6009
Tel: 86-5455
Telex: 93859 PERTH
Cable: HEWPARD PERTH
Hewlett-Packard Australia Pty. Ltd.
121 Wellington Street
Fyshwick, A.C.T. 2609
Tel: 95-2733
Telex: 62650 CANBERRA
Cable: HEWPARD CANBERRA
Hewlett-Packard Australia Pty. Ltd.
5th Floor
Teachers Union Building
495-499 Boundary Street
Spring Hill, 4000 Queensland
Tel: 229-1544
Cable: HEWPARD Brisbane

GUAM
Medical Pocket Calculators Only
Guam Medical Supply, Inc.
Jay Case Building, Room 210
P.O. Box 8947
Tamuning 96911
Tel: 646-4513
Cable: EARMED Guam

HONG KONG
Schmidt & Co (Hong Kong) Ltd
P.O. Box 297
Connaught Centre
39th Floor
Connaught Road, Central
Hong Kong
Tel: 2-25291-5
Telex: 74766 SCHMC HK
Cable: SCHMIDTICO Hong Kong

INDIA
Blue Star Ltd.
Kastur Buildings
Janshedji Tata Rd.
Bombay 400 020
Tel: 29 30 21
Tel: 45 78 61
Cable: BLUEFROST
Blue Star Ltd.
Sahas
414/2 Vir Savarkar Marg
Prabhadevi
Bombay 400 025
Tel: 45 78 87
Telex: 4093
Cable: FROSTBLUE
Blue Star Ltd.
Band Box House
Prabhadevi
Bombay 400 025
Tel: 45 78 61
Telex: 3751
Cable: BLUESTAR
Blue Star Ltd.
1440 Civil Lines
Kanpur 208 001
Tel: 8 88 82
Telex: 292
Cable: BLUESTAR
Blue Star Ltd.
7 Hare Street
P.O. Box 506
Calcutta 700 001
Tel: 23-0131
Telex: 7655
Cable: BLUESTAR
Blue Star Ltd.
7th & 8th Floor
Bhandari House
91 Nehru Place
New Delhi 110024
Tel: 634770 & 635165
Telex: 2483
Cable: BLUESTAR
Blue Star Ltd.
11/11A Magarath Road
Bangalore 560 025
Tel: 55568
Telex: 392
Cable: BLUESTAR
Blue Star Ltd.
Mesaki Mandir
xxx/1678 Mahatma Gandhi Rd
Cochin 682 016
Tel: 37069, 32161, 32282
Tel: 045-6-514
Cable: BLUESTAR

ISRAEL
Electronics & Engineering Div
of Motorola Israel Ltd.
17, Krumenetski Street
P.O. Box 25016
Tel Aviv
Tel: 38973
Telex: 33569
Cable: BASTEL Tel-Aviv

JAPAN
Yokogawa-Hewlett-Packard Ltd.
Ohashi Building
59-1 Yoyogi 1-Chome
Shibuya-ku, Tokyo 151
Tel: 03-370-2261/92
Telex: 232-2024YHP
Cable: YHPMARKET TOK 23-724
Yokogawa-Hewlett-Packard Ltd.
Seto Ibaraki Building
2-8 Kasuga 2-Chome, Ibaraki-shi
Osaka 567
Tel: (0726) 23-1641
Telex: 5332-385 YHP USAKA
Yokogawa-Hewlett-Packard Ltd.
Nakamo Building
24 Kami Sasajima-cho
Nakamura-ku, Nagoya, 450
Tel: (052) 571-5171
Yokogawa-Hewlett-Packard Ltd.
Tanigawa Building
2-24-1 Tsuruya-cho
Kanagawa-ku
Yokohama, 221
Tel: 045-6-514
Telex: 382-3204 YHP YOK

KENYA
Technical Engineering Services
(E.A.) Ltd.
P.O. Box 18311
Nairobi
Tel: 57126/556782
Cable: INTAERID
Medical Only
International Aeradio (E.A.) Ltd.
P.O. Box 19012
Nairobi Airport
Nairobi
Tel: 36055/56
Telex: 22201/22301
Cable: INTAERID Nairobi
KOREA
Samsung Electronics Co., Ltd.
20th Fl. Dongbang Bldg 250, 2-KA
C.P.O. Box 2775
Taeyung-Ro, Chung-Ku
Seoul
Tel: (23) 6811
Telex: 22575
Cable: ELEKSTAR Seoul
MALAYSIA
Teknik Mutu Sdn. Bhd.
2 Lorong 13/6A
Section 13
Petaling Jaya, Selangor
Tel: 54954/5496
Telex: MA 37805
Pictel Engineering
P.O. Box 1917
Lot 259, Satok Road
Kuching, Sarawak
Tel: 2405
Cable: PROTTEL ENG
MOZAMBIQUE
A.N. Gonçalves, Lda
162, 1^o Apt. 14 Av. O Luis
Cana Postal 107
Lourenço Marques
Tel: 27091, 27114
Telex: 5-203 MEGON Mo
Cable: NEGON
NEW ZEALAND
Hewlett-Packard (N.Z.) Ltd.
P.O. Box 9443
Courtney Place
Wellington
Tel: 877-199
Telex: NZ 3839
Cable: HEWPACK Wellington

Yokogawa-Hewlett-Packard Ltd
Mitsui Building
105, Chome-1, San-no-marui
Mito, Ibaragi 310
Tel: 0292-25-7470
Yokogawa-Hewlett-Packard Ltd
Inoue Building
1348-3, Asahi-cho, 1-chome
Atsugi, Kanagawa 243
Tel: 0462-24-0452
Yokogawa-Hewlett-Packard Ltd.
Kimura Building
3rd Floor 20
2-chome, Tsukuba
Kumagaya, Saitama 360
Tel: 0485-24-6553

Hewlett-Packard (N.Z.) Ltd
Pakuranga Professional Centre
267 Pakuranga Highway
Box 51092
Pakuranga
Tel: 369-651
Telex: NZ 3839
Cable: HEWPACK Auckland
Analytical/Medical Only
Medical Supplies N.Z. Ltd.
Scientific Division
79 Carlton Gore Rd., Newmarket
3rd Floor 1234
Auckland
Tel: 75-289
Telex: 2958 MEDISUP
Cable: DENTAL Auckland
Analytical/Medical Only
Medical Supplies N.Z. Ltd.
P.O. Box 1994
147-161 Tory St
Wellington
Tel: 850-759
Telex: 3858
Cable: DENTAL, Wellington
Analytical/Medical Only
Medical Supplies N.Z. Ltd.
P.O. Box 309
239 Shannon Road
Christchurch
Tel: 892-019
Cable: DENTAL, Christchurch
Analytical/Medical Only
Medical Supplies N.Z. Ltd.
303 Great King Street
P.O. Box 233
Dunedin
Tel: 89-817
Cable: DENTAL, Dunedin
NIGERIA
The Electronics
Instrumentations Ltd
N6B/770 Oyo Road
Okeun House
P.M.B. 5402
Ibadan
Tel: 61577
Telex: 31231 TEIL Nigeria
Cable: THETEL Ibadan
The Electronics Instrumentations Ltd
144 Agese Motor Road, Mushin
P.O. Box 6645
Lagos
Cable: THETEL Lagos
PAKISTAN
Mushko & Company, Ltd
Osman Chambers
Abdullah Hatoon Road
Karachi-3
Tel: 511027, 512927
Telex: KR884
Cable: COOPERATOR Karachi
Mushko & Company, Ltd
38B, Satellite Town
Rawalpindi
Tel: 41924
Cable: FEMUS Rawalpindi
Cable: HEWPACK Wellington

PHILIPPINES
The Online Advanced Systems
Corporation
6th Floor, Yujui Co Bldg,
5600 Quinh Paredes St
Binondo, Manila
Tel: 48-71-49, 48-68-53
In Makati, 585-35-51, 85-34-91
Telex: 3274 ONLINE
RHODESIA
Field Technical Sales
45 Kelvin Road North
P.O. Box 3458
Salisbury
Tel: 705231 (5 lines)
Telex: RH 4122
SINGAPORE
Hewlett-Packard Singapore
(Pte.) Ltd
3841/1, Jalan Bukit Merah
Bk 2, 6th Floor, Jalan
Redhill Industrial Estate
Alexandra P.O. Box 58,
Singapore 3
Tel: 633022
Telex: HPSG RS 21486
Cable: HEWPACK, Singapore
SOUTH AFRICA
Hewlett-Packard South Africa
(Pty.) Ltd.
Private Bag Wendywood
Sandton, Transvaal 2144
Hewlett-Packard Center
Daphne Street, Wendywood,
Sandton, Transvaal 2144
Tel: 802-104016
Telex: 8-4782
Cable: HEWPACK JOHANNESBURG
Service Department
Hewlett-Packard South Africa
(Pty.) Ltd.
P.O. Box 39325
Grahamy, Sandton, 2018
451 Wytheby Extension 3,
Sandton, 2001
Tel: 636-8188/9
Telex: 8-2391
Hewlett-Packard South Africa
(Pty.) Ltd.
P.O. Box 120
Howard Place, Cape Province, 7450
Pine Park Center, Forest Drive,
Pinehills, Cape Province, 7405
Tel: 53-7955 Ith 9
Telex: 57-0006
Service Department
Hewlett-Packard South Africa
(Pty.) Ltd.
P.O. Box 37099
Overport, Durban 4067
Brary House
541 Ridge Road
Durban, 4001
Tel: 38-7478
Telex: 5-7954
OTHER AREAS NOT LISTED, CONTACT
Hewlett-Packard Intercontinental
3200 Hillview Ave,
Palo Alto, California 94304
Tel: (415) 493-1501
TWX: 910-373-1267
Cable: HEWPACK Palo Alto
Telex: 034-6300, 034-8493

CANADA

ALBERTA
Hewlett-Packard (Canada) Ltd.
11620A - 168 Street
Edmonton T5M 3T9
Tel: (403) 452-3670
TWX: 610-831-2431 EOTH
Hewlett-Packard (Canada) Ltd.
915-42 Ave S.E. Suite 102
Calgary T2G 1Z1
Tel: (403) 287-1572
TWX: 610-821-841

BRITISH COLUMBIA
Hewlett-Packard (Canada) Ltd.
837 E. Cordova Street
Vancouver V6R 3R2
Tel: (604) 254-0531
TWX: 610-922-5059 VCR

MANITOBA
Hewlett-Packard (Canada) Ltd.
513 Century St.
St. James
Winnipeg R3M 0L5
Tel: (204) 786-7581
TWX: 610-671-3531

NOVA SCOTIA
Hewlett-Packard (Canada) Ltd.
808 Windmill Road
P.O. Box 9331
Dartmouth B2Y 3Z6
Tel: (902) 469-7820
TWX: 610-271-4482 HFX

ONTARIO
Hewlett-Packard (Canada) Ltd.
1020 Morrison Dr.
Oshawa K2H 6K7
Tel: (513) 820-6483
TWX: 610-513-1636
Hewlett-Packard (Canada) Ltd.
6677 Goreway Drive
Mississauga L4V 1M8
Tel: (416) 678-9430
TWX: 610-492-4246

QUEBEC
Hewlett-Packard (Canada) Ltd.
275 Hymus Blvd
Pointe Claire H9R 1G7
Tel: (514) 697-4232
TWX: 610-422-3022
TLX: 05-821521 HPCL

FOR CANADIAN AREAS NOT LISTED
Contact Hewlett-Packard (Canada)
Ltd. in Mississauga.

CENTRAL AND SOUTH AMERICA

ARGENTINA
Hewlett-Packard Argentina
S.A.
Av. Leandro N Alem 822 - 12^o
1001 Buenos Aires
Tel: 31-6053, 4, 5, 6 and 7
Telex: Public Booth 11-9
Cable: HEWPACK ARG

BOLIVIA
Stambur & Mark (Bolivia) Ltda.
Av. Mariscal, Santa Cruz 1342
La Paz
Tel: 40626, 53163, 52421
Telex: 3560014
Cable: BUXMAR
Hewlett-Packard do Brasil
i.e.C. Ltda.
Avenida Rio Negro, 980
Alphaville
Ribeirão Preto, São Paulo
Tel: 22-22-22
Hewlett-Packard do Brasil
i.e.C. Ltda.
Rua Padre Chagas, 32
90000-Porto Alegre-RS
Tel: (0512) 22-2598, 22-9621
Cable: HEWPACK porto Alegre

BRAZIL
Hewlett-Packard do Brasil
i.e.C. Ltda.
Avenida Rio Negro, 980
Alphaville
Ribeirão Preto, São Paulo
Tel: 22-22-22
Hewlett-Packard do Brasil
i.e.C. Ltda.
Rua Padre Chagas, 32
90000-Porto Alegre-RS
Tel: (0512) 22-2598, 22-9621
Cable: HEWPACK porto Alegre

COSTA RICA
Cientifica Costarricense S.A.
Calle Central, Avenidas 1 y 3
Apartado 10159
San José
Tel: 21-86-13
Cable: GALGUR San José
ECUADOR
Medical Only
A.F. Viscaino Compañía Ltda.
Av. Rio Amazonas No. 239
P.O. Box 2925
Quito
Tel: 242-150, 247-033/034
Cable: Astor Quito
Calculators Only
Computadoras y Equipos
Electrónicos
P.O. Box 2695
990 Toledo (y Cordero)
Quito
Tel: 02-2113 Sagita Ed
Cable: Sagita-Quito

CHILE
Instrumentación
Henri A. Langebaek & Kier S.A.
Carretera, 104-475
Santiago
Tel: 69-88-77
Cable: AARIS Bogotá
Tel: 044-400

COLOMBIA
Instrumentación
Henri A. Langebaek & Kier S.A.
Carretera, 104-475
Santiago
Tel: 69-88-77
Cable: AARIS Bogotá
Tel: 044-400

EL SALVADOR
Instrumentación y Procesamiento
Electrónico de El Salvador
Bulevar de los Héroes 11-48
San Salvador
Tel: 252787
GUATEMALA
IPESA
Avenida La Reforma 3-48,
Zona 9
Guatemala City
Tel: 63627, 64786
Telex: 4192 Teletro Gu
MEXICO
Hewlett-Packard Mexicana,
S.A. de C.V.
Calle Adalid No. 21, 11^o Piso
Col. del Valle
Mexico 12, D.F.
Tel: (905) 543-42-32
Telex: D17-74-507

Hewlett-Packard Mexicana,
S.A. de C.V.
Ave. Constitución No 2184
Monterrey, N.L.
Tel: 48-71-32, 48-71-84
Telex: 038-843
NICARAGUA
IPESA
Roberto Terán G
Apartado Postal 569
Edificio Terán
Managua
Tel: 25114, 23412, 23454
Cable: ROTERAN Managua
PANAMA
Electrónico Balboa, S.A.
P.O. Box 4929
Calle Samuel Lewis
Ciudad de Panama
Tel: 64-2700
Telex: 3431103 Curunda,
Canal Zone
Cable: ELECTRON Panama

PARAGUAY
Z.J. Melandri S.R.L.
División Aparatos y Equipos
Médicos
División Aparatos y Equipos
Científicos y de Investigación
Edificio Claire H9R 1G7
Chile-482, Edificio Victoria
Asunción
Tel: 91-271, 91-272
Cable: RAMEL
PERU
Compañía Electro Médica S.A.
Los Flamencos 145
San Isidro Casilla 1030
Lima 1
Tel: 41-4325
Cable: ELMED Lima
PUERTO RICO
Hewlett-Packard Inter-Americanas
Puerto Rico Branch Office
Calle 272,
No. 203 Urb. Country Club
Carolina 00924
Tel: (809) 762-7255
Telex: 345 0514

URUGUAY
Pablo Ferrando S.A.
Comercial e industrial
Avenida Italia 2877
Casilla de Correo 370
Montevideo
Tel: 40-3102
Cable: RADUM Montevideo
VENEZUELA
Hewlett-Packard de Venezuela
C.A.
P.O. Box 50933
Caracas 105
Los Ruices Norte
3a Transversal
Edificio Segre
Caracas 107
Tel: 35-00-11 (20 lines)
Telex: 25146 HEWPACK
Cable: HEWPACK Caracas
FOR AREAS NOT LISTED, CON
Hewlett-Packard
Inter-Americanas
3200 Hillview Ave
Palo Alto, California 94304
Tel: (415) 493-1501
TWX: 910-373-1260
Cable: HEWPACK Palo Alto
Telex: 034-6300, 034-8493

EUROPE, NORTH AFRICA AND MIDDLE EAST

AUSTRIA
Hewlett-Packard Ges m b H
Handelskai 52
P.O. Box 7
A-1205 Vienna
Tel: (0222) 351621 to 27
Cable: HEWPAK Vienna
Telex: 75923 hewpak a

BELGIUM
Hewlett-Packard Benelux
S.A./N.V.
Avenue de Col-Vert, 1,
(Groenkranslaan)
B-1170 Brussels
Tel: (02) 672 22 40
Cable: PALOENB Brussels
Telex: 23 494 paroen brv

CYPRUS
Kypromics
P.O. Gregorios & Xenopoulos Rd
P.O. Box 1152
CY-Nicosia
Tel: 4562929
Cable: KYPRONICS PANDEHIS
Telex: 3018

CZECHOSLOVAKIA
Vývojová a Pírovní Základna
Výzkumných Ústavů v Bechovicích
CSR-25097
Bechovice u Prahy
Tel: 69 93 41
Telex: 121333

Institute of Medical Biophysics
Vyskumny Ústav Lekarskej Biologie
Jedlova 6
CS-88348 Bratislava-Kramar
Tel: 44-55145-541

DDR
Entwicklungsabtor der TU Dresden
Forschungsanstalt Mensberg
DDR-7300

Waldheim/Meinsberg
Tel: 37 667
Telex: 112145

Export Contact AG Zuerich
Guetlihofstrasse 15
1040 Berlin
Tel: 42-74-12
Telex: 111889

DENMARK
Hewlett-Packard A/S
Dalenevej 52
DK-3460 Birkerød
Tel: (02) 61 56 40
Cable: HEWPAK AS
Telex: 166 40 hpas

Hewlett-Packard A/S
Narsvej 1
DK-8600 Silkeborg
Tel: (06) 82 71 66
Telex: 166 40 hpas
Cable: HEWPAK AS

FINLAND
Hewlett-Packard OY
Teknillisuuntie 5
P.O. Box 5
SF-00211 Helsinki 21
Tel: (90) 6923031
Cable: HEWPAK OY Helsinki
Telex: 12-1563 HEWPA SF

FRANCE
Hewlett-Packard France
Quartier de Courcouronnes
Boulevard de la République
F-91401 Orsay Cédex
Tel: (1) 907 78 25
Cable: HEWPAK Orsay
Telex: 600048

Hewlett-Packard France
Agence Régionale
de Strasbourg
Chemin des Mouilles
P. 162
F-69130 Ecully
Tel: (78) 33 81 25
Cable: HEWPAK Ecully
Telex: 31 06 13

Hewlett-Packard France
Agence Régionale
Pénicente de la Céprière
Chemin de la Céprière, 20
F-31300 Toulouse-Le Mirail
Tel: (61) 40 11 12
Cable: HEWPAK 51957
Telex: 510957

Hewlett-Packard France
Agence Régionale
Aéroport principal de
Marseille-Mangane
F-13721 Marignane
Tel: (91) 89 12 38
Cable: HEWPAK MARGN
Telex: 410770

Hewlett-Packard France
Agence Régionale
63, Avenue de Rochester
B.P. 1124
F-35014 Rennes Cédex
Tel: (99) 36 33 21
Cable: HEWPAK 74912
Telex: 740912

Hewlett-Packard France
Agence Régionale
74, Allée de la Robertsau
F-67000 Strasbourg
Tel: (89) 35 29 21
Telex: 8921

Hewlett-Packard STRBG
Tel: 37 667
Telex: 112145

Export Contact AG Zuerich
Guetlihofstrasse 15
1040 Berlin
Tel: 42-74-12
Telex: 111889

Hewlett-Packard France
Centre d'Affaires Paris-Nord
Bâtiment Ampère
Rue de la Commune de Paris
B.P. 900
F-93153
Le Blanc Mesnil Cédex
Tel: (01) 931 88 50

**GERMAN FEDERAL
REPUBLIC**
Hewlett-Packard GmbH
Vertriebszentrale Frankfurt
Bernstrasse 117
Postfach 560 140
D-6000 Frankfurt 56
Tel: (069) 58 04-1
Cable: HEWPAKSA Frankfurt
Telex: 94 13249 optfmd

Hewlett-Packard GmbH
Technisches Buero Böblingen
Hertensbergerstrasse 110
D-7030 Böblingen, Württemberg
Tel: (07031) 657-11
Cable: HEWPAK Böblingen
Telex: 07265739 bbn

Hewlett-Packard GmbH
Technisches Buero Düsseldorf
Emanuel-Leutze-Str. 1 (Seestern)
D-4000 Düsseldorf 11
Tel: (0211) 597 11-1
Telex: 08586 533 hppd d
Cable: HEWPAK GmbH
Technisches Buero Hamburg
Wendenstrasse 23
D-2000 Hamburg 1
Tel: (040) 24 13 63
Cable: HEWPAKSA Hamburg
Telex: 21 63 032 hphd d

Hewlett-Packard GmbH
Technisches Buero Hannover
Am Grossefeld 6
D-3000 Hannover-Kleefeld 91
Tel: (0511) 46 60 01
Telex: 092 3299

Hewlett-Packard GmbH
Technisches Buero Nürnberg
Neumeyer Str. 90
D-9100 Nürnberg
Tel: (0911) 56 30 83/85
Telex: 0623 860

Hewlett-Packard GmbH
Technisches Buero München
Unterhanger Strasse 28
ISAR Center
D-8012 Otobrunn
Tel: (089) 501 30 61/7
Cable: HEWPAKSA München
Telex: 0524885

Hewlett-Packard GmbH
Technisches Buero Berlin
Kett Strasse 2-4
D-1000 Berlin 30
Tel: (030) 24 90 86
Telex: 18 3405 hphd d

GREECE
Kostas Karayannis
19, Pissinias Street
GR-Athens 126
Tel: 3237371
Cable: RAKAR Athens
Telex: 21 59 62 rkar gr

ANTECO
G. Papatianassidou & Co.
Narf 17
GR - Athens 103
Tel: 522 1915
Cable: INTEKNIKA Athens
Telex: 21 5329 INTE GR

Medical Only
Technomed Hellas Ltd
52, Siquia Street
GR - Athens 135
Tel: 362 6972, 363 3830
Cable: etalath athens
Telex: 21-4993 ETAL GR

HUNGARY
MTA
Műszerügyi és Mérőtechnikai
Szolgálat
Linnéi Krt. 67
1391 Budapest VI
Tel: 42 03 36
Telex: 22 51 14

ICELAND
Medical Only
Elding Trading Company Inc.
Hafnarhvoli - Tryggvatouli
IS-Reykjavik
Tel: 1 58 20
Cable: ELDING Reykjavik

IRAN
Hewlett-Packard Iran Ltd
No. 13 Fourtenth St
Mirmasad Avenue
P.O. Box 41/2419
IR-Tehran
Tel: 851082-7
Telex: 213405 HEWP IR

Hewlett-Packard Trading Co.
Mansoor City
Baghdad
Tel: 5512927
Telex: 2455 Hepairaq ik
Cable: HEWPAKAD
Baghdad Iraq

IRAQ
Hewlett-Packard Trading Co.
Mansoor City
Baghdad
Tel: 5512927
Telex: 2455 Hepairaq ik
Cable: HEWPAKAD
Baghdad Iraq

NETHERLANDS
Hewlett-Packard Benelux N.V.
Van Heuven Goedhartlaan 121
P.O. Box 667
NL-1134 Amstelveen
Tel: (020) 47 20 21
Cable: PALOENB Amsterdam
Telex: 13 216 hepa nl

NORWAY
Hewlett-Packard Norge A/S
Nevnesen 13
Box 149
N-1344 Haslum
Tel: (02) 53 83 60
Telex: 16621 hpnas n

POLAND
Biuro Informatyki Technicznej
Hewlett-Packard
Ul. Stawki 2, 6P
00-950 Warszawa
Tel: 393962/395187
Telex: 81 24 53 hepa pl

PORTUGAL
Telectra-Empresa Técnica de
Equipamentos Eléctricos S a r l
Rua Rodrigo da Fonseca 103
P.O. Box 2531
P-Lisbon 1
Tel: (1) 59 60 72
Cable: TELECTRA Lisbon
Telex: 12598

Medical only
Mundinter
Intercomercial Mundial de Comércio
S a r l
Av. A de A. de A. de A. 138
P.O. Box 2761
P-Lisbon
Tel: (1) 53 21 31/7
Cable: INTERCAMBIO Lisbon

RUMANIA
Hewlett-Packard Reprezentanta
BD N. Balcescu 16
Bucharest
Tel: (062) 138885
Telex: 10440

SAUDI ARABIA
Modern Electronic Establishment
King Abdul Aziz Str (Head office)
P.O. Box 1228
Jeddah
Tel: 31-172 332201
Cable: ELECTRA
P.O. Box 2728 (Service center)
Riyadh
Tel: 62596-66232
Cable: RAOUF

SPAIN
Hewlett-Packard Española, S.A.
Jerre No 3
E-Madrid 16
Tel: (1) 458 26 00 (10 lines)
Telex: 20515 hpe
Hewlett-Packard Española, S.A.
Cable: Hewpac London
Tel: 847178/9

Hewlett-Packard Ltd
Trafalgar House
Navigation Road
Aldricham
Cheshire WA14 1NU
Tel: (061) 928 6422
Cable: Hewpac Manchester
Telex: 668068

SWITZERLAND
Hewlett-Packard (Schweiz) AG
Zürcherstrasse 20
P.O. Box 307
CH-8502 Schlieren-Zürich
Tel: (01) 730 52 40/730 18 21
Herts
Tel: (0462) 52824/56704
Telex: 825881

USSR
Hewlett-Packard
Representative Office USSR
Petrovsky Boulevard 4/17-KW 12
Moscow 101000
Tel: 294-2024
Telex: 7825 hewpak su

YUGOSLAVIA
Iskra-standard/Hewlett-Packard
161000 Ljubljana
Tel: 31 6367, 19687, 14268
Cable: SAWAH, Damascus
Telex: 315683

IRELAND
Hewlett-Packard Ltd.
King Street Lane
GB-Winnerah, Wokingham
Berks, RG11 5AR
Tel: (0734) 78 47 74
Telex: 847178/848179

ITALY
Hewlett-Packard Italiana S.p.A.
Via Ameglio Vaspucci 2
Casella postale 3645
I-20100 Milano
Tel: (2) 6251 (10 lines)
Cable: HEWPAKIT Milano
Telex: 32046

Hewlett-Packard Italiana S.p.A.
Via Pietro Maroncelli 40
(ang. Via Visconti)
I-35100 Padova
Tel: (49) 66 48 88
Telex: 41612 Hewpack

Medical only
Hewlett-Packard Italiana S.p.A.
Via d'Agliardi 7
I-56100 Pisa
Tel: (050) 2 32 04
Telex: 32046 via Milano

Hewlett-Packard Italiana S.p.A.
Via G. Armettan 10
I-00143 Roma
Tel: (06) 54 69 61
Telex: 61514
Cable: HEWPAKIT Roma

Hewlett-Packard Italiana S.p.A.
Corso Giovanni Lanza 94
I-10130 Torino
Tel: (011) 682245/659308

Medical/Calculators Only
Hewlett-Packard Italiana S.p.A.
Via Principe Nicola 4/3 G/C
I-95126 Catania
Tel: (095) 37 05 04
Hewlett-Packard Italiana S.p.A.
Via Ameglio Vaspucci, 9
I-80142 Napoli
Tel: (081) 33 77 11

Hewlett-Packard Italiana S.p.A.
Via E. Mass. 9/B
I-40137 Bologna
Tel: (051) 30 76 87

KUWAIT
Al-Khalafiyah Trading &
Contracting Co
P.O. Box 830
Kuwait
Tel: 42 49 10
Cable: VISCOUNT

LUXEMBURG
Hewlett-Packard Benelux
S.A./N.V.
Avenue de Col-Vert, 1,
(Groenkranslaan)
B-1170 Brussels
Tel: (02) 672 22 40
Cable: PALOENB Brussels
Telex: 23 494

MOROCCO
Gereq
190, Blvd. Brahim Roudani
Casablanca
Tel: 25-16 76-25-90-99
Cable: Gereq-Casa
Telex: 23739

NETHERLANDS
Hewlett-Packard Benelux N.V.
Van Heuven Goedhartlaan 121
P.O. Box 667
NL-1134 Amstelveen
Tel: (020) 47 20 21
Cable: PALOENB Amsterdam
Telex: 13 216 hepa nl

NORWAY
Hewlett-Packard Norge A/S
Nevnesen 13
Box 149
N-1344 Haslum
Tel: (02) 53 83 60
Telex: 16621 hpnas n

POLAND
Biuro Informatyki Technicznej
Hewlett-Packard
Ul. Stawki 2, 6P
00-950 Warszawa
Tel: 393962/395187
Telex: 81 24 53 hepa pl

PORTUGAL
Telectra-Empresa Técnica de
Equipamentos Eléctricos S a r l
Rua Rodrigo da Fonseca 103
P.O. Box 2531
P-Lisbon 1
Tel: (1) 59 60 72
Cable: TELECTRA Lisbon
Telex: 12598

Medical only
Mundinter
Intercomercial Mundial de Comércio
S a r l
Av. A de A. de A. de A. 138
P.O. Box 2761
P-Lisbon
Tel: (1) 53 21 31/7
Cable: INTERCAMBIO Lisbon

RUMANIA
Hewlett-Packard Reprezentanta
BD N. Balcescu 16
Bucharest
Tel: (062) 138885
Telex: 10440

SAUDI ARABIA
Modern Electronic Establishment
King Abdul Aziz Str (Head office)
P.O. Box 1228
Jeddah
Tel: 31-172 332201
Cable: ELECTRA
P.O. Box 2728 (Service center)
Riyadh
Tel: 62596-66232
Cable: RAOUF

SPAIN
Hewlett-Packard Española, S.A.
Jerre No 3
E-Madrid 16
Tel: (1) 458 26 00 (10 lines)
Telex: 20515 hpe
Hewlett-Packard Española, S.A.
Cable: Hewpac London
Tel: 847178/9

Hewlett-Packard Ltd
Trafalgar House
Navigation Road
Aldricham
Cheshire WA14 1NU
Tel: (061) 928 6422
Cable: Hewpac Manchester
Telex: 668068

IRELAND
Hewlett-Packard Ltd.
King Street Lane
GB-Winnerah, Wokingham
Berks, RG11 5AR
Tel: (0734) 78 47 74
Telex: 847178/848179

ITALY
Hewlett-Packard Italiana S.p.A.
Via Ameglio Vaspucci 2
Casella postale 3645
I-20100 Milano
Tel: (2) 6251 (10 lines)
Cable: HEWPAKIT Milano
Telex: 32046

Hewlett-Packard Italiana S.p.A.
Via Pietro Maroncelli 40
(ang. Via Visconti)
I-35100 Padova
Tel: (49) 66 48 88
Telex: 41612 Hewpack

Medical only
Hewlett-Packard Italiana S.p.A.
Via d'Agliardi 7
I-56100 Pisa
Tel: (050) 2 32 04
Telex: 32046 via Milano

Hewlett-Packard Italiana S.p.A.
Via G. Armettan 10
I-00143 Roma
Tel: (06) 54 69 61
Telex: 61514
Cable: HEWPAKIT Roma

Hewlett-Packard Italiana S.p.A.
Corso Giovanni Lanca 94
I-10130 Torino
Tel: (011) 682245/659308

Medical/Calculators Only
Hewlett-Packard Italiana S.p.A.
Via Principe Nicola 4/3 G/C
I-95126 Catania
Tel: (095) 37 05 04
Hewlett-Packard Italiana S.p.A.
Via Ameglio Vaspucci, 9
I-80142 Napoli
Tel: (081) 33 77 11

Hewlett-Packard Italiana S.p.A.
Via E. Mass. 9/B
I-40137 Bologna
Tel: (051) 30 76 87

KUWAIT
Al-Khalafiyah Trading &
Contracting Co
P.O. Box 830
Kuwait
Tel: 42 49 10
Cable: VISCOUNT

LUXEMBURG
Hewlett-Packard Benelux
S.A./N.V.
Avenue de Col-Vert, 1,
(Groenkranslaan)
B-1170 Brussels
Tel: (02) 672 22 40
Cable: PALOENB Brussels
Telex: 23 494

MOROCCO
Gereq
190, Blvd. Brahim Roudani
Casablanca
Tel: 25-16 76-25-90-99
Cable: Gereq-Casa
Telex: 23739

NETHERLANDS
Hewlett-Packard Benelux N.V.
Van Heuven Goedhartlaan 121
P.O. Box 667
NL-1134 Amstelveen
Tel: (020) 47 20 21
Cable: PALOENB Amsterdam
Telex: 13 216 hepa nl

NORWAY
Hewlett-Packard Norge A/S
Nevnesen 13
Box 149
N-1344 Haslum
Tel: (02) 53 83 60
Telex: 16621 hpnas n

POLAND
Biuro Informatyki Technicznej
Hewlett-Packard
Ul. Stawki 2, 6P
00-950 Warszawa
Tel: 393962/395187
Telex: 81 24 53 hepa pl

PORTUGAL
Telectra-Empresa Técnica de
Equipamentos Eléctricos S a r l
Rua Rodrigo da Fonseca 103
P.O. Box 2531
P-Lisbon 1
Tel: (1) 59 60 72
Cable: TELECTRA Lisbon
Telex: 12598

Medical only
Mundinter
Intercomercial Mundial de Comércio
S a r l
Av. A de A. de A. de A. 138
P.O. Box 2761
P-Lisbon
Tel: (1) 53 21 31/7
Cable: INTERCAMBIO Lisbon

RUMANIA
Hewlett-Packard Reprezentanta
BD N. Balcescu 16
Bucharest
Tel: (062) 138885
Telex: 10440

SAUDI ARABIA
Modern Electronic Establishment
King Abdul Aziz Str (Head office)
P.O. Box 1228
Jeddah
Tel: 31-172 332201
Cable: ELECTRA
P.O. Box 2728 (Service center)
Riyadh
Tel: 62596-66232
Cable: RAOUF

SPAIN
Hewlett-Packard Española, S.A.
Jerre No 3
E-Madrid 16
Tel: (1) 458 26 00 (10 lines)
Telex: 20515 hpe
Hewlett-Packard Española, S.A.
Cable: Hewpac London
Tel: 847178/9

Hewlett-Packard Ltd
Trafalgar House
Navigation Road
Aldricham
Cheshire WA14 1NU
Tel: (061) 928 6422
Cable: Hewpac Manchester
Telex: 668068

IRELAND
Hewlett-Packard Ltd.
King Street Lane
GB-Winnerah, Wokingham
Berks, RG11 5AR
Tel: (0734) 78 47 74
Telex: 847178/848179

ITALY
Hewlett-Packard Italiana S.p.A.
Via Ameglio Vaspucci 2
Casella postale 3645
I-20100 Milano
Tel: (2) 6251 (10 lines)
Cable: HEWPAKIT Milano
Telex: 32046

Hewlett-Packard Italiana S.p.A.
Via Pietro Maroncelli 40
(ang. Via Visconti)
I-35100 Padova
Tel: (49) 66 48 88
Telex: 41612 Hewpack

Medical only
Hewlett-Packard Italiana S.p.A.
Via d'Agliardi 7
I-56100 Pisa
Tel: (050) 2 32 04
Telex: 32046 via Milano

Hewlett-Packard Italiana S.p.A.
Via G. Armettan 10
I-00143 Roma
Tel: (06) 54 69 61
Telex: 61514
Cable: HEWPAKIT Roma

Hewlett-Packard Italiana S.p.A.
Corso Giovanni Lanca 94
I-10130 Torino
Tel: (011) 682245/659308

Medical/Calculators Only
Hewlett-Packard Italiana S.p.A.
Via Principe Nicola 4/3 G/C
I-95126 Catania
Tel: (095) 37 05 04
Hewlett-Packard Italiana S.p.A.
Via Ameglio Vaspucci, 9
I-80142 Napoli
Tel: (081) 33 77 11

Hewlett-Packard Italiana S.p.A.
Via E. Mass. 9/B
I-40137 Bologna
Tel: (051) 30 76 87

KUWAIT
Al-Khalafiyah Trading &
Contracting Co
P.O. Box 830
Kuwait
Tel: 42 49 10
Cable: VISCOUNT

LUXEMBURG
Hewlett-Packard Benelux
S.A./N.V.
Avenue de Col-Vert, 1,
(Groenkranslaan)
B-1170 Brussels
Tel: (02) 672 22 40
Cable: PALOENB Brussels
Telex: 23 494

MOROCCO
Gereq
190, Blvd. Brahim Roudani
Casablanca
Tel: 25-16 76-25-90-99
Cable: Gereq-Casa
Telex: 23739

NETHERLANDS
Hewlett-Packard Benelux N.V.
Van Heuven Goedhartlaan 121
P.O. Box 667
NL-1134 Amstelveen
Tel: (020) 47 20 21
Cable: PALOENB Amsterdam
Telex: 13 216 hepa nl

NORWAY
Hewlett-Packard Norge A/S
Nevnesen 13
Box 149
N-1344 Haslum
Tel: (02) 53 83 60
Telex: 16621 hpnas n

POLAND
Biuro Informatyki Technicznej
Hewlett-Packard
Ul. Stawki 2, 6P
00-950 Warszawa
Tel: 393962/395187
Telex: 81 24 53 hepa pl

PORTUGAL
Telectra-Empresa Técnica de
Equipamentos Eléctricos S a r l
Rua Rodrigo da Fonseca 103
P.O. Box 2531
P-Lisbon 1
Tel: (1) 59 60 72
Cable: TELECTRA Lisbon
Telex: 12598

Medical only
Mundinter
Intercomercial Mundial de Comércio
S a r l
Av. A de A. de A. de A. 138
P.O. Box 2761
P-Lisbon
Tel: (1) 53 21 31/7
Cable: INTERCAMBIO Lisbon

RUMANIA
Hewlett-Packard Reprezentanta
BD N. Balcescu 16
Bucharest
Tel: (062) 138885
Telex: 10440

SAUDI ARABIA
Modern Electronic Establishment
King Abdul Aziz Str (Head office)
P.O. Box 1228
Jeddah
Tel: 31-172 332201
Cable: ELECTRA
P.O. Box 2728 (Service center)
Riyadh
Tel: 62596-66232
Cable: RAOUF

SPAIN
Hewlett-Packard Española, S.A.
Jerre No 3
E-Madrid 16
Tel: (1) 458 26 00 (10 lines)
Telex: 20515 hpe
Hewlett-Packard Española, S.A.
Cable: Hewpac London
Tel: 847178/9

Hewlett-Packard Ltd
Trafalgar House
Navigation Road
Aldricham
Cheshire WA14 1NU
Tel: (061)



www.valuetronics.com