

## Errata

**Title & Document Type:** 8691A-8694A Sweep Oscillator Operating and Service Manual

**Manual Part Number:** 08691-90021

**Revision Date:** November 1968

### About this Manual

We've added this manual to the Agilent website in an effort to help you support your product. This manual provides the best information we could find. It may be incomplete or contain dated information, and the scan quality may not be ideal. If we find a better copy in the future, we will add it to the Agilent website.

### HP References in this Manual

This manual may contain references to HP or Hewlett-Packard. Please note that Hewlett-Packard's former test and measurement, life sciences, and chemical analysis businesses are now part of Agilent Technologies. The HP XXXX referred to in this document is now the Agilent XXXX. For example, model number HP8648A is now model number Agilent 8648A. We have made no changes to this manual copy.

### Support for Your Product

Agilent no longer sells or supports this product. You will find any other available product information on the Agilent Test & Measurement website:

[www.agilent.com](http://www.agilent.com)

Search for the model number of this product, and the resulting product page will guide you to any available information. Our service centers may be able to perform calibration if no repair parts are needed, but no other support from Agilent is available.



**Agilent Technologies**

**OPERATING AND SERVICE MANUAL**

**RF UNITS**

**8691A**

**8692A**

**8693A**

**8694A**

**INCLUDING  
H01, H02**

**HEWLETT  PACKARD**

## **CERTIFICATION**

*Hewlett-Packard Company certifies that this product met its published specifications at the time of shipment from the factory. Hewlett-Packard further certifies that its calibration measurements are traceable to the United States National Bureau of Standards, to the extent allowed by the Bureau's calibration facility, and to the calibration facilities of other International Standards Organization members.*

## **WARRANTY**

This Hewlett-Packard instrument product is warranted against defects in material and workmanship for a period of one year from date of shipment. For conditions of warranty for backward wave oscillators and traveling wave tubes, refer to page 1-4 of this manual. During the warranty period, Hewlett-Packard Company will, at its option, either repair or replace products which prove to be defective.

For warranty service or repair, this product must be returned to a service facility designated by HP. Buyer shall prepay shipping charges to HP and HP shall pay shipping charges to return the product to Buyer. However, Buyer shall pay all shipping charges, duties, and taxes for products returned to HP from another country.

HP warrants that its software and firmware designated by HP for use with an instrument will execute its programming instructions when properly installed on that instrument. HP does not warrant that the operation of the instrument, or software, or firmware will be uninterrupted or error free.

## **LIMITATION OF WARRANTY**

The foregoing warranty shall not apply to defects resulting from improper or inadequate maintenance by Buyer, Buyer-supplied software or interfacing, unauthorized modification or misuse, operation outside of the environmental specifications for the product, or improper site preparation or maintenance.

**NO OTHER WARRANTY IS EXPRESSED OR IMPLIED. HP SPECIFICALLY DISCLAIMS THE IMPLIED WARRANTIES OF MERCHANTABILITY AND FITNESS FOR A PARTICULAR PURPOSE.**

## **EXCLUSIVE REMEDIES**

**THE REMEDIES PROVIDED HEREIN ARE BUYER'S SOLE AND EXCLUSIVE REMEDIES. HP SHALL NOT BE LIABLE FOR ANY DIRECT, INDIRECT, SPECIAL, INCIDENTAL, OR CONSEQUENTIAL DAMAGES, WHETHER BASED ON CONTRACT, TORT, OR ANY OTHER LEGAL THEORY.**

## **ASSISTANCE**

*Product maintenance agreements and other customer assistance agreements are available for Hewlett-Packard products.*

*For any assistance, contact your nearest Hewlett-Packard Sales and Service Office. Addresses are provided at the back of this manual.*

# **RF UNITS**

## **8691A/8692A/8693A/8694A**

**INCLUDING H01-, H02- MODELS**

**SERIALS PREFIXED: 835-, 838-**

This Operating and Service Manual applies to HP 8691-4A instruments with serial number prefixes 835-, 838-.

**SERIAL PREFIXES NOT LISTED**

For new instruments with serial number prefixes above 838, a "Manual Changes" sheet is supplied with this manual.

©COPYRIGHT

HEWLETT-PACKARD COMPANY

1966

1400 FOUNTAIN GROVE PARKWAY, SANTA ROSA, CALIFORNIA, 95404, U.S.A.

**02334-2 Printed: NOVEMBER 1968**

**HEWLETT**  **PACKARD**

**TABLE OF CONTENTS**

Section	Title	Page	Section	Title	Page
<b>I</b>	<b>GENERAL INFORMATION . . . . .</b>	<b>1-1</b>	<b>II</b>	<b>Maintenance (Cont' d)</b>	
1-1.	Description . . . . .	1-1	2-11.	BWO Tube Replacement . . . . .	2-2
1-4.	Instrument Identification . . . . .	1-1	2-12.	Warranty . . . . .	2-2
1-6.	Installation. . . . .	1-2	2-14.	Ordering a Replacement BWO Tube. . . . .	2-2
1-8.	Operation . . . . .	1-2	2-16.	BWO Tube Removal . . . . .	2-2
1-10.	Principles of Operation . . . . .	1-2	2-17.	BWO Tube Installation . . . . .	2-2
<b>II</b>	<b>MAINTENANCE. . . . .</b>	<b>2-1</b>	2-20.	Adjustment . . . . .	2-3
2-1.	Introduction . . . . .	2-1	<b>III</b>	<b>REPLACEABLE PARTS . . . . .</b>	<b>3-1</b>
2-3.	Performance Tests. . . . .	2-1	3-1.	Introduction . . . . .	3-1
2-5.	Troubleshooting . . . . .	2-1	3-3.	Ordering Information . . . . .	3-1
2-7.	Detailed Component Maintenance . . . . .	2-1	<b>IV</b>	<b>SCHEMATIC DIAGRAMS . . . . .</b>	<b>4-1</b>
2-9.	Directional Detector Repair . . . . .	2-1	4-1.	Introduction . . . . .	4-1
	Appendix I . . . . .	Directional Detectors 786D/787D/788C			
	Appendix II . . . . .	Backdating Manual Changes			

**LIST OF ILLUSTRATIONS**

Number	Title	Page	Number	Title	Page
1-1.	Typical 8691A-8694A RF Unit . . . . .	1-0	2-5.	Component and Adjustment Identifi- fication, Interior Top View . . . . .	2-8
1-2.	Front and Rear Panel Controls, Connectors, and Indicators . . . . .	1-3	2-6.	Component Identification Assembly A1	2-9
2-1.	Maintenance Setup Number 1. . . . .	2-3	2-7.	Waveforms. . . . .	2-9
2-2.	Maintenance Setup Number 2. . . . .	2-4	2-8.	Component Identification, Assembly A2 . . . . .	2-10
2-3.	Maintenance Setup Number 3. . . . .	2-6	4-1.	Schematic Diagram Notes . . . . .	4-1
2-4.	Component Identification, Interior Left Side . . . . .	2-7	4-2.	RF Unit . . . . .	4-3
			4-3.	Output Configurations . . . . .	4-5

**LIST OF TABLES**

Number	Title	Page	Number	Title	Page
1-1.	Specifications . . . . .	1-1	2-3.	Adjustments . . . . .	2-3
2-1.	Test Equipment Required for Maintenance . . . . .	2-1	3-1.	Reference Designation Index . . . . .	3-2
2-2.	Maximum BWO Currents, mA . . . . .	2-2	3-2.	Replaceable Parts . . . . .	3-7
			3-3.	Code List of Manufacturers . . . . .	3-9

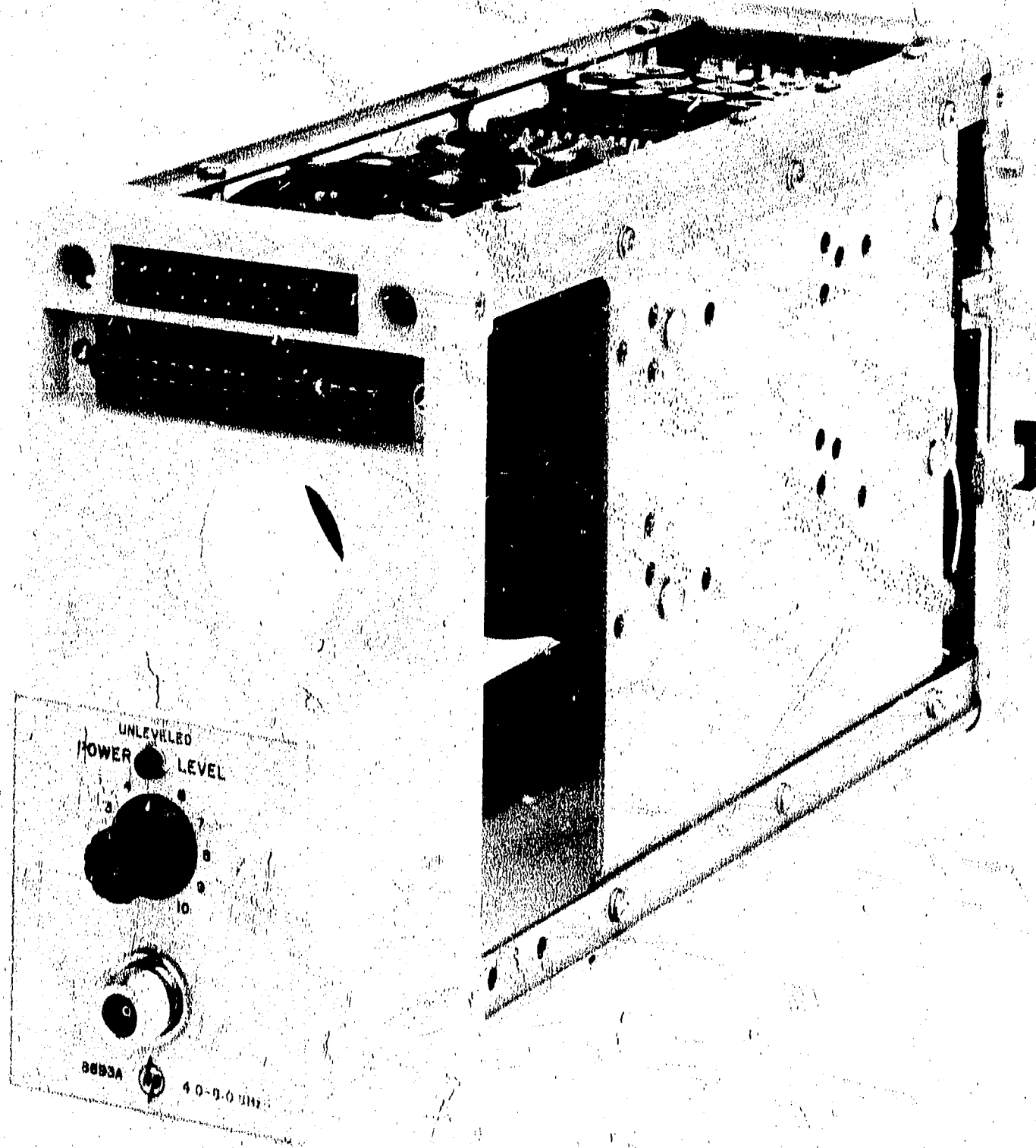

Figure 1-1. Typical 8691A-8694A RF Unit

## SECTION I

### GENERAL INFORMATION

#### 1-1. DESCRIPTION.

1-2. The Model 8691A through 8694A RF Units, including H01 and H02 Models, combine with the 8690A Sweep Oscillator to form an electronically tuned microwave signal source with a frequency range of 1 GHz to 12.4 GHz. Individual RF Unit Model specifications are given in Table 1-1.

1-3. The 8691A - 8694A RF Units are grid modulated by circuits included within the RF Unit, and have

coaxial RF output. Option 01 RF Units contain an internal leveling loop. Internal leveling allows the Sweep Oscillator - RF Unit combination to automatically hold amplitude constant as output frequency changes.

#### 1-4. INSTRUMENT IDENTIFICATION.

1-5. Each Sweep Oscillator carries a two-section, eight-digit serial number (000-00000) of which the first three digits are a prefix. The contents of this manual apply to those RF Units having the serial number prefix(es) listed on the title page. Revisions required to

Table 1-1. Specifications

<p><u>Residual AM:</u> At least 40 dB below CW output.</p> <p><u>Spurious Signals:</u> Harmonics, at least 20 dB below CW output; non-harmonics, at least 40 dB below CW output.</p> <p><u>Reference Output:</u> Direct-coupled voltage proportional to RF frequency, approximately 0 v at the low end of the band, increasing approximately 40 v/octave. Output impedance, 30,000 ohms.</p> <p><u>Leveling Indicator:</u> Front-panel indicator lights when power level set too high to permit leveling over entire selected sweep range or when operating in unlevelled mode.</p> <p><u>Equivalent Source Match:</u> Externally Levelled: Depends upon coupler. Unlevelled: Less than 2.5:1.</p> <p><u>Power Variation, Unlevelled:</u> Less than 10 dB over the entire band.</p> <p><u>Weight:</u> 8691A, 8692A: Net, 17 lbs. (7,6 kg). Shipping, 25 lbs. (11,3 kg). 8693A, 8694A: Net, 10 lbs. (4,5 kg). Shipping, 18 lbs. (8,1 kg).</p> <p><u>Furnished:</u> 8690A dial scale corresponding to frequency range of RF Unit.</p> <p style="text-align: center;"><b>MODEL 8691A RF UNIT</b> (Installed in 8690A Sweep Oscillator)</p> <p><u>Frequency Range:</u> 1 to 2 GHz</p> <p><u>Frequency Accuracy</u> (at maximum levelled power): ±1%</p> <p><u>Maximum Levelled Power:</u> At least 100 mW</p>	<p><u>RF Power Control:</u> BWO Grid</p> <p><u>Frequency Stability:</u> With Temperature: ±0.01%/°C With 10% Change in Line Voltage: ±500 kHz With 10-dB Power Level Change: typically ±20 MHz Residual FM: &lt; 30 kHz peak</p> <p><u>Power Variation, External Leveling*:</u> ±0.2 dB.</p> <p><u>Output Impedance and/or Connector:</u> 50 ohms/ Type N</p> <p><u>Option 01 Internal Leveling:</u> Power Variation: ±0.4 dB Equivalent Source Match: 1.13:1</p> <p style="text-align: center;"><b>MODEL 8692A RF UNIT</b> (Installed in 8690A Sweep Oscillator)</p> <p><u>Frequency Range:</u> 2 to 4 GHz</p> <p><u>Frequency Accuracy</u> (at maximum levelled power): ±1%</p> <p><u>Maximum Levelled Power:</u> At least 70 mW</p> <p><u>RF Power Control:</u> BWO Grid</p> <p><u>Frequency Stability:</u> With Temperature: ±0.01%/°C With 10% Change in Line Voltage: ±500 kHz With 10-dB Power Level Change: typically ±40 MHz Residual FM: &lt; 30 kHz peak</p> <p><u>Power Variation, External Leveling*:</u> ±0.2 dB</p> <p><u>Output Impedance and/or Connector:</u> 50 ohms/ Type N</p> <p><u>Option 01 Internal Leveling:</u> Power Variation: ±0.4 dB Equivalent Source Match: 1.16:1</p>
---	---

Table 1-1. Specifications (Continued)

MODEL 8693A RF UNIT (Installed in 8690A Sweep Oscillator)			
<u>Frequency Range:</u> 4 to 8 GHz	With 10% Change in Line Voltage: $\pm 1$ MHz		
<u>Frequency Accuracy</u> (at maximum leveled power): $\pm 1\%$	With 10-dB Power Level Change: typically $\pm 80$ MHz		
<u>Maximum Leveled Power:</u> At least 30 mW	Residual FM: $< 50$ kHz peak		
<u>RF Power Control:</u> BWO Grid	<u>Power Variation, External Leveling:</u> * $\pm 0.2$ dB		
<u>Frequency Stability:</u> With Temperature: $\pm 0.01\%/^{\circ}\text{C}$	<u>Output Impedance and/or Connector:</u> 50 ohms/ Type N		
	<u>Option 01 Internal Leveling:</u> Power Variation (into matched load): $\pm 0.5$ dB Equivalent Source Match (approx): 1.25:1		
MODELS 8694A, H01-8694A, H02-8694A RF UNITS (Installed in 8690A Sweep Oscillator)			
	8694A	H01-8694A	H02-8694A
<u>Frequency Range</u>	8 to 12.4 GHz	7 to 12.4 GHz	7 to 11 GHz
<u>Frequency Accuracy</u> (at maximum leveled power)	$\pm 1\%$	$\pm 1\%$	$\pm 1\%$
<u>Maximum Leveled Power</u>	At least 50 mW	At least 25 mW	At least 25 mW
<u>RF Power Control</u>	BWO Grid	BWO Grid	BWO Grid
<u>Frequency Stability</u> With Temperature	$\pm 0.01\%/^{\circ}\text{C}$	$\pm 0.01\%/^{\circ}\text{C}$	$\pm 0.01\%/^{\circ}\text{C}$
With 10% Change in Line Voltage	$\pm 1$ MHz	$\pm 1$ MHz	$\pm 1$ MHz
Residual FM	$< 60$ kHz peak	$< 60$ kHz peak	$< 60$ kHz peak
<u>Power Variation, External Leveling*</u>	$\pm 0.2$ dB	$\pm 0.2$ dB	$\pm 0.2$ dB
<u>Output impedance and/or Connector</u>	50 ohms/Type N	50 ohms/Type N	50 ohms/Type N
<u>Option 01 Internal Leveling</u> Power Variation (into matched load)	$\pm 0.75$ dB	$\pm 0.75$ dB	$\pm 0.75$ dB
Equivalent Source Match (approx.)	2:1	2:1	2:1
* Excluding coupler and detector variation.			

adapt this manual to serial number prefixes not listed on the title page are contained in a yellow-sheet Manual Changes insert supplied with the manual. For information concerning serial number prefixes not listed either on the title page or in an insert, contact one of the Hewlett-Packard sales and service offices listed at the rear of this manual.

### 1-6. INSTALLATION.

1-7. The RF Unit is designed to be installed into the 8690A Sweep Oscillator from the rear. To install the RF Unit, perform the following steps:

a. Push the plastic retaining catch inward to release the handle on the rear of the RF Unit.

b. Raise the RF Unit handle 90 degrees to a position perpendicular to the RF Unit rear panel.

c. Gently push the RF Unit into the 8690A Sweep Oscillator from the rear.

d. Return the RF Unit handle to the locked position, in line with the RF Unit rear panel. This step should firmly secure the RF Unit into the 8690A Sweep Oscillator.

### 1-8. OPERATION.

1-9. Operating procedures of the Sweep Oscillator-RF Unit combinations are given in the 8690A Sweep Oscillator Manual. Figure 1-2 shows the front and rear views of a typical 8691A-8694A RF Unit. Front and rear panel controls, connectors and indicators are described in Figure 1-2.

### 1-10. PRINCIPLES OF OPERATION.

1-11. Principles of circuit operation of the Sweep Oscillator - RF Unit combinations are given in the 8690A Sweep Oscillator Manual. Circuit functions included in the RF Unit are: (1) microwave signal generation by the backward wave oscillator (BWO) tube, (2) BWO anode voltage and shaping for proper BWO currents, (3) BWO helix voltage shaping for frequency accuracy, (4) grid modulation, (5) unleveled lamp control, and (6) internal leveling in Option 01 Models.



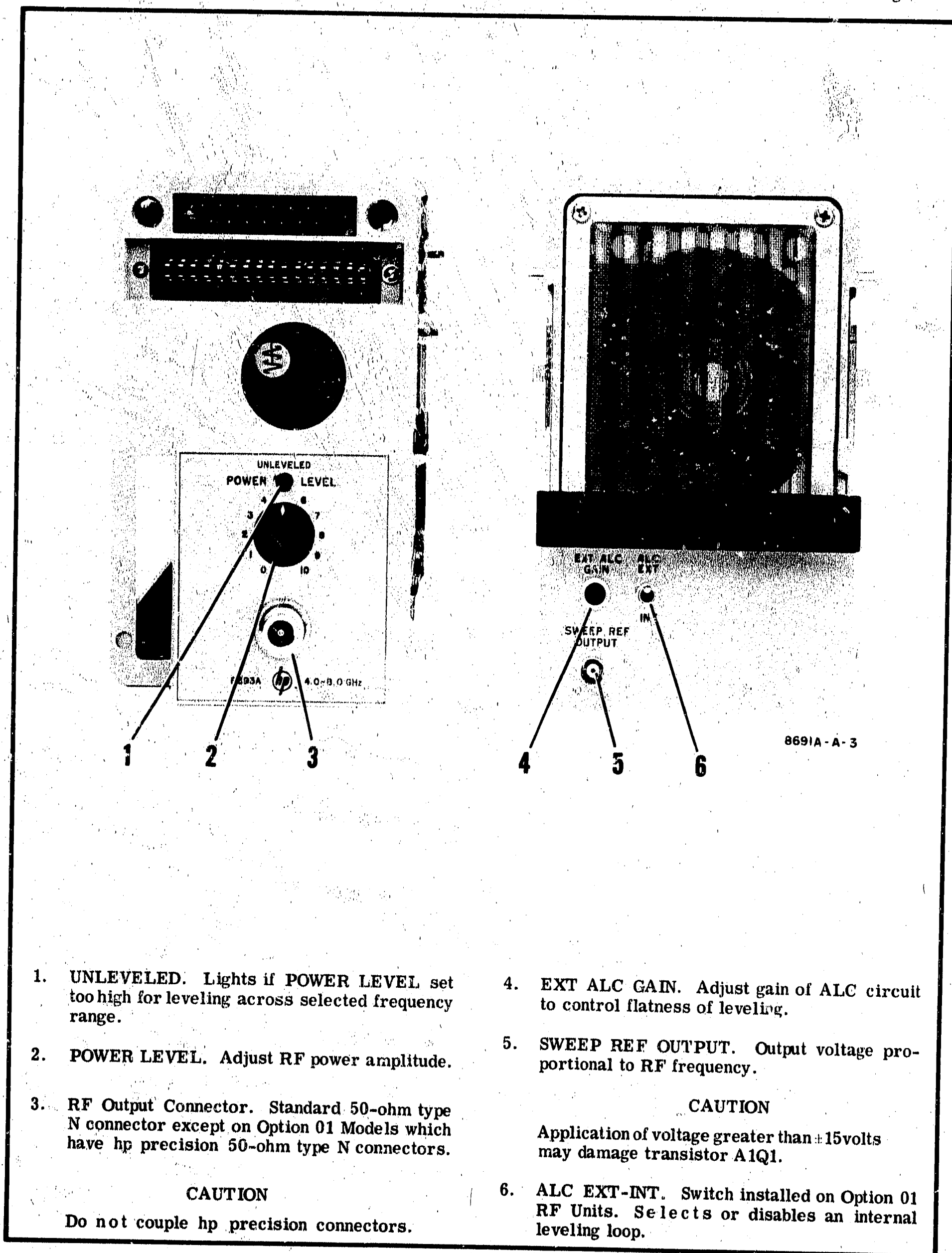

Figure 1-2. Front and Rear Panel Controls, Connectors, and Indicators

# MAINTENANCE

## SECTION II MAINTENANCE

### 2-1. INTRODUCTION.

2-2. This section provides adjustment procedures for the circuits included within the RF Unit. In addition, procedures for BWO replacement and the required electrical adjustments after replacement are given. Test equipment required for RF Unit maintenance is listed in Table 2-1.

### 2-3. PERFORMANCE TESTS.

2-4. Front panel controlled performance tests in the 8690A Sweep Oscillator Manual include tests of the RF Unit electrical specifications given in Table 1-1. If the electrical performance of the Sweep Oscillator-RF Unit combination fails to meet any of the specifications listed in Table 1-1, and a circuit malfunction is not suspected, refer to the adjustment paragraphs. If substandard performance occurs, and a circuit malfunction is suspected, refer to the troubleshooting paragraphs in the 8690A Sweep Oscillator Manual.

### 2-5. TROUBLESHOOTING.

2-6. Complete troubleshooting procedures for all Sweep Oscillator-RF Unit combinations are included

in the 8690A Sweep Oscillator Manual. Where applicable, these troubleshooting procedures analyze the circuit functions contained in the RF Unit. If a circuit malfunction has occurred in the RF Unit, sufficient detailed information is provided at that point in the troubleshooting analysis to define the smallest functional circuit block that contains the malfunctioning circuit. Appropriate references are then made to this Manual.

### 2-7. DETAILED COMPONENT MAINTENANCE.

2-8. Information on etched circuit board repair, including component, transistor, and tube socket replacement, and etched conductor repair is given in the maintenance section of the 8690A Sweep Oscillator Manual.

### 2-9. DIRECTIONAL DETECTOR REPAIR.

2-10. Instructions for repairing the Directional Detector Assembly A4 in the Option 01 RF Units are contained in the Operating Note included as Appendix I in this manual.

Table 2-1. Test Equipment Required for Maintenance

Instrument	Critical Specifications	Recommended Models
Oscilloscope	Vertical Bandwidth: 5 MHz Vertical Sensitivity: 5 mV/cm Sweep Time Accuracy: $\pm 3\%$	hp 140 with 1402 and 1420 Plug-Ins hp 175 with 1752 Plug-In
Crystal Detector	Frequency Range: Same as RF Unit used Sensitivity: 100 mV dc from $< 0.35$ mW, high level; $> 0.4$ mV dc/ $\mu$ W, low level Frequency Response: $\pm 0.5$ dB or better	hp 423
Fixed Attenuator	Frequency Range: Same as RF Unit used Attenuation: nominal 10 dB nominal 20 dB	hp 8491 Option 10: 10 dB Option 20: 20 dB
Frequency Meter	Frequency Range: Same as RF Unit used Accuracy: $\pm 0.1\%$	hp 536 hp 537
Power Meter and Thermistor Mount	Frequency Range: Same as RF Unit used Power Range: $1\mu$ W to 10 mW	hp 431 with hp 478 and hp 486
Waveguide-to-Coaxial Adapter	Frequency Range: Same as RF Unit used	hp H281, X281
DC Voltmeter	Range: 0 to $\pm 300$ V Accuracy: $\pm 0.2\%$ minimum Input Impedance: 10 megohms	hp 405BR hp 3440/3441
Clip-On DC Ammeter	Range: 10 mA to 5 amps Accuracy: $\pm 5\%$	hp 428

**2-11. BWO TUBE REPLACEMENT.**

**2-12. WARRANTY.**

2-13. BWO tube V1 is not manufactured by Hewlett-Packard and therefore is not covered by the Sweep Oscillator warranty. A separate, manufacturer's warranty covers the BWO tube. Both Watkins-Johnson Company (Stewart Division) and Varian BWO tubes are warranted for heater operation of 2500 hours, or one year, whichever occurs first. If the BWO tube fails within this warranty period, see the Warranty Claim and Adjustment Procedure at the rear of this manual.

**2-14. ORDERING A REPLACEMENT BWO TUBE.**

2-15. When ordering a replacement BWO tube from Hewlett-Packard order, in addition, a replacement Time Meter (A3M1). See Paragraph 3-6.

**2-16. BWO TUBE REMOVAL.**

- a. Disconnect Sweep Oscillator from AC line power.
- b. Remove RF Unit.
- c. Disconnect BWO tube RF Output. Watkins-Johnson (Stewart) BWO tubes are equipped with impedance-matching balun units attached to the two white RF output leads. The balun consists of a brass-colored assembly and a flanged female-to-female type N adapter. **IMPORTANT:** Do not disassemble the balun unit or detach the adapter from the balun. Both units are part of the BWO tube and must be included with a BWO tube returned for warranty adjustment. New and replacement BWO tubes are supplied with a balun and adapter attached.
- d. Disconnect BWO tube leads from terminal assembly A3.
- e. Remove 4 screws fastening BWO tube to chassis. (Detach and save aluminum mounting blocks.)
- f. Remove BWO tube.

**2-17. BWO TUBE INSTALLATION.**

**2-18. MECHANICAL.**

- a. Be sure Sweep Oscillator is disconnected from AC line power.
- b. Bolt two aluminum mounting blocks to BWO so bolt heads are recessed in countersunk holes. Tighten bolts securely.
- c. Bolt BWO tube to RF Unit chassis. Tighten mounting bolts.
- d. Connect BWO tube RF output as originally connected.
- e. Install replacement Time Meter (A3M1) on A3 etched circuit, locating timing gap over time scale zero line.

**2-19. ELECTRICAL ADJUSTMENTS.**

- a. Before connecting BWO tube leads to A3 assembly adjust anode voltage as follows:
  - (1) Set Sweep Oscillator for CW (single-frequency) operation at some frequency above the middle of the RF tuning range.
  - (2) Measure anode voltage at Test Point 2, on Assembly A3, and adjust A1R42, Anode Adjust, to give anode voltage within  $\pm 5$  volts of the operating value on the BWO tube label.
- b. Disconnect Sweep Oscillator from AC line power; then connect BWO tube leads to appropriate A3 terminals. (Use tube data sheet to identify leads.)
- c. Install RF Unit and Turn on Sweep Oscillator and allow a few minutes for the BWO tube to reach operating temperature.
- d. Set Sweep Oscillator for CW operation at the highest frequency in the RF tuning range. Set POWER LEVEL for maximum output.
- e. Measure BWO tube anode voltage at Test Point 2, on Assembly A3, and monitor current in BWO tube cathode lead using clip-on DC Ammeter (Table 2-1). Adjust A1R42, Anode Adjust, to obtain top frequency cathode current specified on tube data sheet.
- f. Equalize RF power output over tuning range as follows:
  - (1) Connect equipment as in Figure 2-1. Omit connection to Power Meter Level Input. Obtain CW operation and set POWER LEVEL to MAX CW. Set Sweep Oscillator for CW operation, and POWER LEVEL for maximum output.
  - (2) Measuring current in BWO tube cathode and helix leads, tune RF output to frequency in lower half of RF tuning range at which RF output is minimum. Adjust A1R40, ANODE SHAPE ADJ for maximum RF output without exceeding maximum cathode and helix currents specified in Table 2-2.

Note

Excessive helix current actuates 8690A Helix Over-current relay K3, starting a sequence which disconnects BWO operating voltages. To reconnect voltages, set LINE to OFF, then back to RF and wait for time delay to recycle.

Table 2-2. Maximum BWO Currents, mA

RF Unit Model	Watkins-Johnson		Varian		
	Helix	Cathode	Helix	Cathode	Anode
8691A	4.0	17.0			
8692A	3.5	15.0			
8693A	3.0	12.0	30.0	42.0	10.0
8694A	3.0	12.0	30.0	42.0	10.0
H01-8694A	3.0	12.0	30.0	42.0	10.0
H02-8694A	3.0	12.0	30.0	42.0	10.0

- (3) Manually tune through the full band checking that neither cathode nor helix current exceeds the maximum values listed in Table 2-2. If maximum values are exceeded, readjust A1R42, ANODE ADJ, and/or A1R40, ANODE SHAPE ADJ, to reduce current. ANODE SHAPE ADJ affects lower half of RF tuning range; ANODE ADJ affects full band.
- (4) Repeat steps (2) and (3) to obtain best full-band RF power flatness within the current limits specified in Table 2-2.

g. Perform the adjustment procedures given in Table 2-3, except for the Crystal ALC Leveled Output Adjustment.

**2-20. ADJUSTMENT.**

2-21. The adjustment procedures given in Table 2-3 are to be performed in order listed, and should only be made with the RF Unit installed in an 8690A Sweep Oscillator known to be accurately calibrated. Accurate 8690A Sweep Oscillator calibration can be ensured

by performing the adjustment procedures listed in the Sweep Oscillator Manual. If an adjustment requirement cannot be satisfied, refer to the troubleshooting paragraphs in the 8690A Sweep Oscillator Manual.

2-22. ADJUSTMENT CONTROL SETTINGS. Unless otherwise specified, set the 8690A Sweep Oscillator controls for all adjustments as follows:

LINE . . . . .	RF	
START/CW		} Low end of specified range, any RF Unit
MARKER 1 - START/CW		
MARKER 2 - STOP		
STOP/ΔF		
SWEEP SELECTOR . . . . .	CW	
FUNCTION pushbuttons . . . . .	All Released	
AMPLITUDE MOD pushbuttons . . . . .	All Released	
ALC . . . . .	Released	
MANUAL SWEEP . . . . .	MAX CCW	
SWEEP TIME (SEC) . . . . .	100-10	
VERNIER . . . . .	LINE SYNC	
INT SQ WAVE FREQ. . . . .	MAX CCW	
BLANKING . . . . .	OFF	
PWR MTR LEVEL . . . . .	OFF	
ALL BNC INPUTS and OUTPUTS . . . . .	No connection	

Table 2-3. Adjustments

**1. ANODE VOLTAGE.**

Procedure

- a. Ensure that RF Unit is properly installed in 8690A.
- b. Set 8690A controls as follows:  
FUNCTION . . . . . START-STOP  
SWEEP SELECTOR . . . . . CW  
START/CW . . . High end of specified range
- c. Set RF Unit POWER LEVEL control to MAX CW.
- d. Connect 3440 Voltmeter (Table 2-1) from Test Point 2 on Terminal Assembly A3 to 8690A chassis ground.
- e. Adjust A1R42, ANODE ADJUST, for the voltage shown on the BWO tube label.
- f. Perform ANODE SHAPING and BWO CURRENTS adjustment procedures.

**2. ANODE SHAPING.**

Procedure

- a. Ensure that RF Unit is properly installed in 8690A.
- b. Set 8690A controls as follows:  
FUNCTION . . . . . START-STOP  
SWEEP SELECTOR . . . . . CW  
ALC . . . . . Depressed  
PWR MTR LEVEL . . . . . ON  
START/CW . . . Low end of specified range
- c. Connect equipment as shown in Figure 2-1, according to RF Unit used.

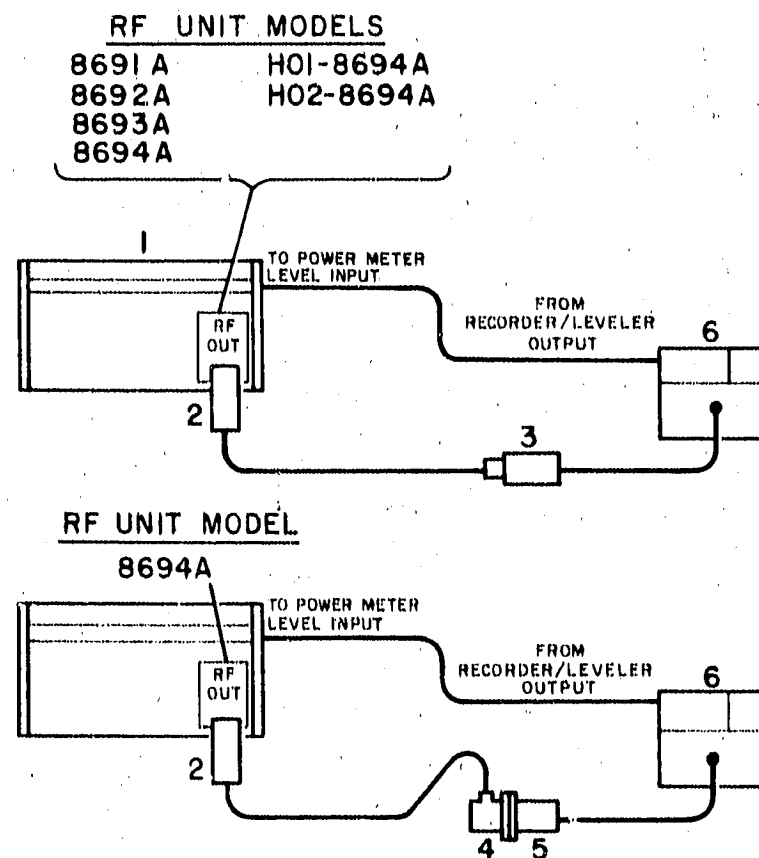

- 1. SWEEP OSCILLATOR hp 8690A
- 2. ATTENUATOR hp 8491 - As required to reduce power to thermistor mount to less than 10mW
- 3. THERMISTOR MOUNT hp 478
- 4. COAXIAL TO WAVEGUIDE ADAPTER hp X281
- 5. THERMISTOR MOUNT hp X486
- 6. POWER METER hp 431

Figure 2-1. Maintenance Setup Number 1

Table 2-3. Adjustments (Cont' d)

d. Measure leveled power output. If power level is not at least the appropriate minimum level tabulated below, proceed to step e.

RF Unit Model	Power Level, dBm
8691A	20.0
8692A	18.5
8693A	14.8
8694A	17.0
H01-8694A	14.0
H02-8694A	14.0

e. Adjust A1R40, ANODE SHAPE ADJ, to achieve the appropriate power output specified in step d. Do not adjust A1R40 ANODE SHAPE ADJUST, unless necessary.

e. If low or high end current is greater than specified in Table 2-2, adjust A1R42, ANODE ADJUST, to bring current within limits.

f. Perform ANODE SHAPING adjustment procedure, and steps a through e of BWO CURRENTS adjustment procedure until further adjustments are not required.

g. On Watkins-Johnson BWO, connect 428 DC Ammeter clip-on probe around cathode lead (yellow). On Varian BWO, connect 428 DC Ammeter clip-on probe around anode lead (blue).

h. Measure cathode (Watkins-Johnson BWO) or anode (Varian BWO) current with START/CW at low end of specified range; then at high end of specified range.

i. Repeat steps e and f.

### 3. BWO CURRENTS.

#### Procedure

- Ensure that RF Unit is properly installed in 8690A.
- Set 8690A controls as follows:  
FUNCTION . . . . . START-STOP  
SWEEP SELECTOR . . . . . CW  
START/CW . . . Low end of specified range
- Connect 428 DC Ammeter (Table 2-1) clip-on probe around BWO helix lead (red).
- Measure helix current with START/CW at low end of specified range; then at high end of specified range.

### 4. HELIX VOLTAGE SHAPING.

#### Procedure

- Ensure that RF Unit is properly installed in 8690A.
- Set 8690A controls as follows:  
FUNCTION . . . . . ΔF  
SWEEP SELECTOR . . . . . MANUAL  
STOP/ΔF . . . . . MAX CW
- Connect 3440 Voltmeter (Table 2-1) from Test Point 4 on 8690A Helix Amplifier Assembly A4 to 8690A chassis ground.

#### RF UNIT MODELS

8691A  
8692A  
8693A

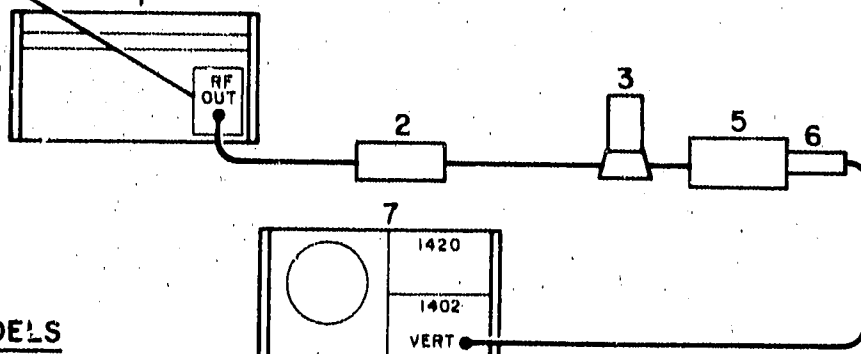

#### RF UNIT MODELS

8694A  
H01-8694A  
H02-8694A

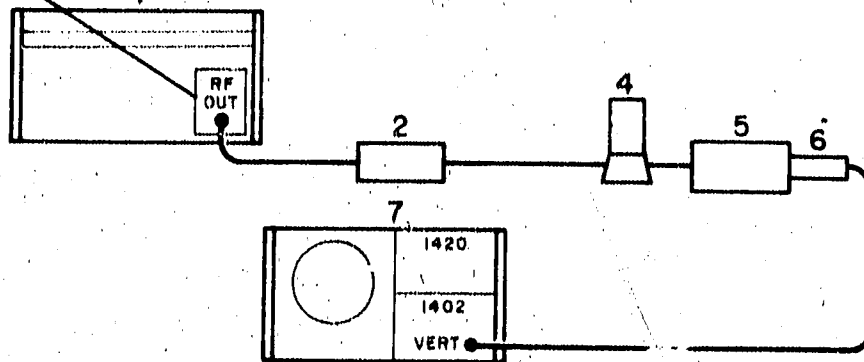

#### NOTE

- Use the appropriate equipment

RF UNIT	FREQUENCY METER
8691A	hp 536
8692A	536
8693A	537
H01-8694A	537
H02-8694A	537

- SWEEP OSCILLATOR hp 8690A
- ATTENUATOR hp 8491 - As required to reduce power to Crystal Detector to less than 100mW
- FREQUENCY METER (Refer to Note 1)
- FREQUENCY METER hp 537

- CRYSTAL DETECTOR hp 423
- 100 OHM LOAD RESISTOR hp 11523 (hp 422, 423, 424 Option 02)
- OSCILLOSCOPE hp 140

Figure 2-2. Maintenance Setup Number 2

Table 2-3. Adjustments (Cont' d)

- d. Set START/CW and MANUAL SWEEP for 69.5 Vdc at Test Point 4 on 8690A Assembly A4.
- e. Adjust A1R24, SHAPE ADJ, on "A" Modulator Assembly A1, for approximately 0.0 Vdc across A1CR3.
- f. Connect equipment as shown in Figure 2-2.
- g. Set START/CW and MANUAL SWEEP for 3.00 ±0.01 Vdc at Test Point 4 on 8690A Assembly A4.
- h. Adjust A2R12, on Freq Shape Assembly A2, for low end frequency of specified range. Use frequency meter and oscilloscope display to determine frequency setting.
- i. Set START/CW and MANUAL SWEEP for 38.00 ±0.01 Vdc at Test Point 4 on 8690A Assembly A4.
- j. Adjust A2R13, on Freq Shape Assembly A2, for midpoint frequency of specified range. Use frequency meter and oscilloscope display to determine frequency setting.
- k. Repeat steps g through j until adjustments are not necessary.
- l. Set START/CW and MANUAL SWEEP for 73.00 ±0.01 Vdc at Test Point 4 on 8690A Assembly A4.
- m. Adjust A1R24, SHAPE ADJ, on "A" Modulator Assembly A1, for high end frequency of specified range.

**5. FREQUENCY ACCURACY.**

Procedure

- a. Ensure that RF Unit is properly installed in 8690A.
- b. Set 8690A controls as follows:  
 FUNCTION . . . . . ΔF  
 SWEEP SELECTOR . . . . . MANUAL  
 STOP/ΔF . . . . . MAX CW
- c. Connect equipment as shown in Figure 2-2.
- d. Connect 3440 Voltmeter (Table 2-1) from Test Point 4 on 8690A Helix Amplifier Assembly A4 to 8690A chassis ground.
- e. Set START/CW and MANUAL SWEEP for voltages at Test Point 4 on 8690A Assembly A4 as listed in step g, according to RF Unit used.
- f. Determine RF output frequency using frequency meter and oscilloscope display. Frequency accuracy test limits are given in step g.
- g. If necessary, set frequency of RF output by compromise adjustment of A1R24, SHAPE ADJ, A2R12, and A2R13.

Vdc at Test Point 4, 8690A Assembly A4	Frequency (GHz)					
	8691A	8692A	8693A	8694A	H01-8694A	H02-8694A
73.00 ± 0.01	2.000	4.000	8.000	12.40	12.40	11.00
66.00 ± 0.01	1.900	3.800	7.600	11.96	11.86	10.60
59.00 ± 0.01	1.800	3.600	7.200	11.52	11.32	10.20
52.00 ± 0.01	1.700	3.400	6.800	11.08	10.78	9.800
45.00 ± 0.01	1.600	3.200	6.400	10.64	10.24	9.400
38.00 ± 0.01	1.500	3.000	6.000	10.20	9.700	9.000
31.00 ± 0.01	1.400	2.800	5.600	9.760	9.160	8.600
24.00 ± 0.01	1.300	2.600	5.200	9.320	8.620	8.200
17.00 ± 0.01	1.200	2.400	4.800	8.880	8.080	7.800
10.00 ± 0.01	1.100	2.200	4.400	8.440	7.540	7.400
3.00 ± 0.01	1.000	2.000	4.000	8.000	7.000	7.000
<b>TEST LIMIT (%)</b>	±0.8	±0.8	±0.8	±0.8	±0.8	±0.8

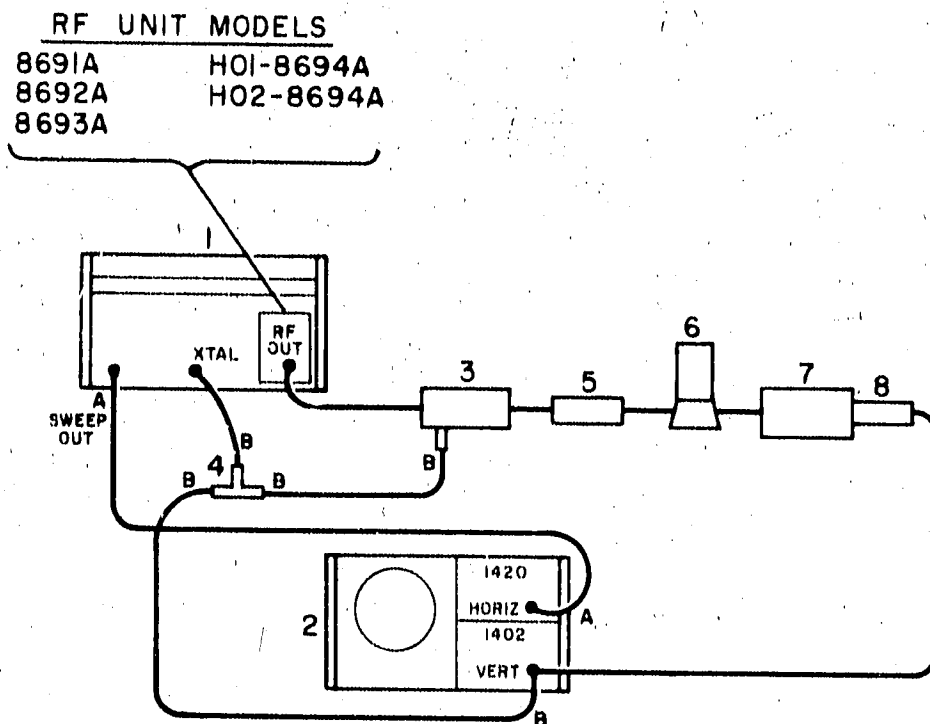

NOTE

1. Use the appropriate equipment

RF UNIT	DIRECTIONAL DETECTOR	FREQUENCY METER
8691A	hp 786	hp 536
8692A	787	536
8693A	788	537
HOI-8694A	Narda 22440 with hp423 Crystal Detector	537
HO2-8694A		537
8694A		537

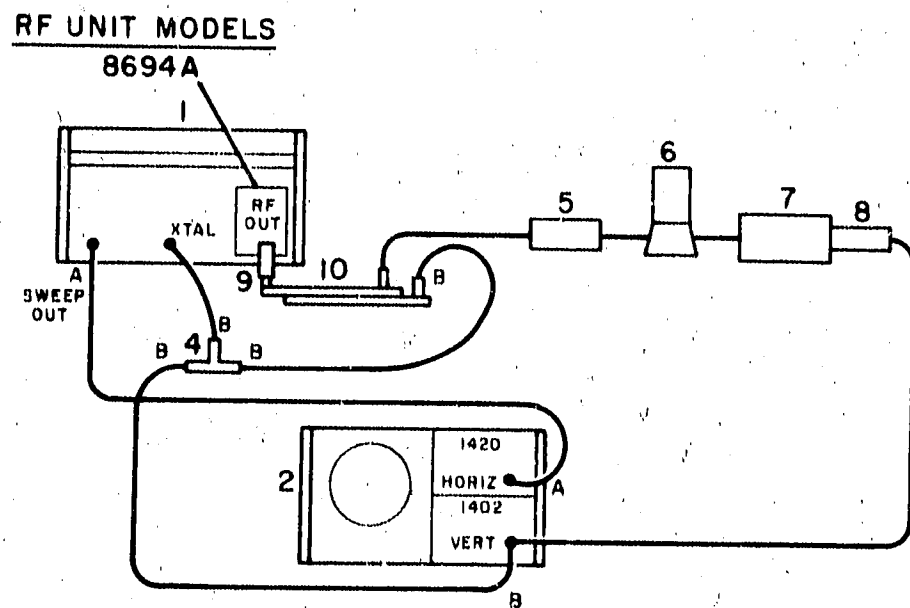

1. SWEEP OSCILLATOR hp 8690A
2. OSCILLOSCOPE hp 140
3. DIRECTIONAL DETECTOR (Refer to Note 1)
4. BNC TEE CONNECTOR
5. ATTENUATOR hp 8491, As required to reduce power to Crystal Detector to less than 100mW
6. FREQUENCY METER (Refer to Note 1)
7. CRYSTAL DETECTOR hp 423
8. 100 OHM LOAD RESISTOR hp 11523 (hp 422, 423, 424 Option 02)
9. MALE N to MALE N ADAPTER
10. DIRECTIONAL DETECTOR hp 789 (Refer to Note 1)

8691A-0-1

Figure 2-3. Maintenance Setup Number 3



Table 2-3. Adjustments (Cont' d)

6. BWO GRID LEVEL.	7. CRYSTAL ALC LEVELED OUTPUT.
<p><u>Procedure</u></p> <ol style="list-style-type: none"> <li>a. Ensure that RF Unit is properly installed in 8690A.</li> <li>b. Set 8690A controls as follows:                      FUNCTION . . . . . START-STOP                      SWEEP SELECTOR . . . . . AUTO                      START/CW . . . Low end of specified range                      STOP/ΔF. . . . High end of specified range                      AMPLITUDE MOD. . . . . INT SQ WAVE                      SWEEP TIME (SEC) . . . . . .01 SEC</li> <li>c. Set RF Unit POWER LEVEL control to MAX CW.</li> <li>d. Connect equipment as shown in Figure 2-2. Connect 8690A SWEEP OUT to horizontal input of oscilloscope.</li> <li>e. Adjust A1R14, GRID LEVEL ADJ, so power output is off during the negative going portion of the square wave modulation signal across the specified range. The display base line should approximate a straight line.</li> </ol>	<p><u>Procedure</u></p> <ol style="list-style-type: none"> <li>a. Ensure that RF Unit is properly installed in 8690A.</li> <li>b. Connect equipment as shown in Figure 2-3. Omit connection C and connection B from BNC tee connector to vertical input of oscilloscope.</li> <li>c. Set 8690A controls as follows:                      SWEEP SELECTOR . . . . . AUTO                      START/CW . . . Low end of specified range                      STOP/ΔF. . . . High end of specified range                      ALC . . . . . Depressed                      PWR MTR LEVEL. . . . . OFF                      ALC EXT-INT (Option 01 Units). . . . INT                      SWEEP TIME (SEC) . . . Suitable for display</li> <li>d. Observe detected power on oscilloscope display.</li> <li>e. Adjust A1R1, LEVEL SHUNT, so that the maximum RF power output portion of the display curve just begins to level off.</li> </ol>

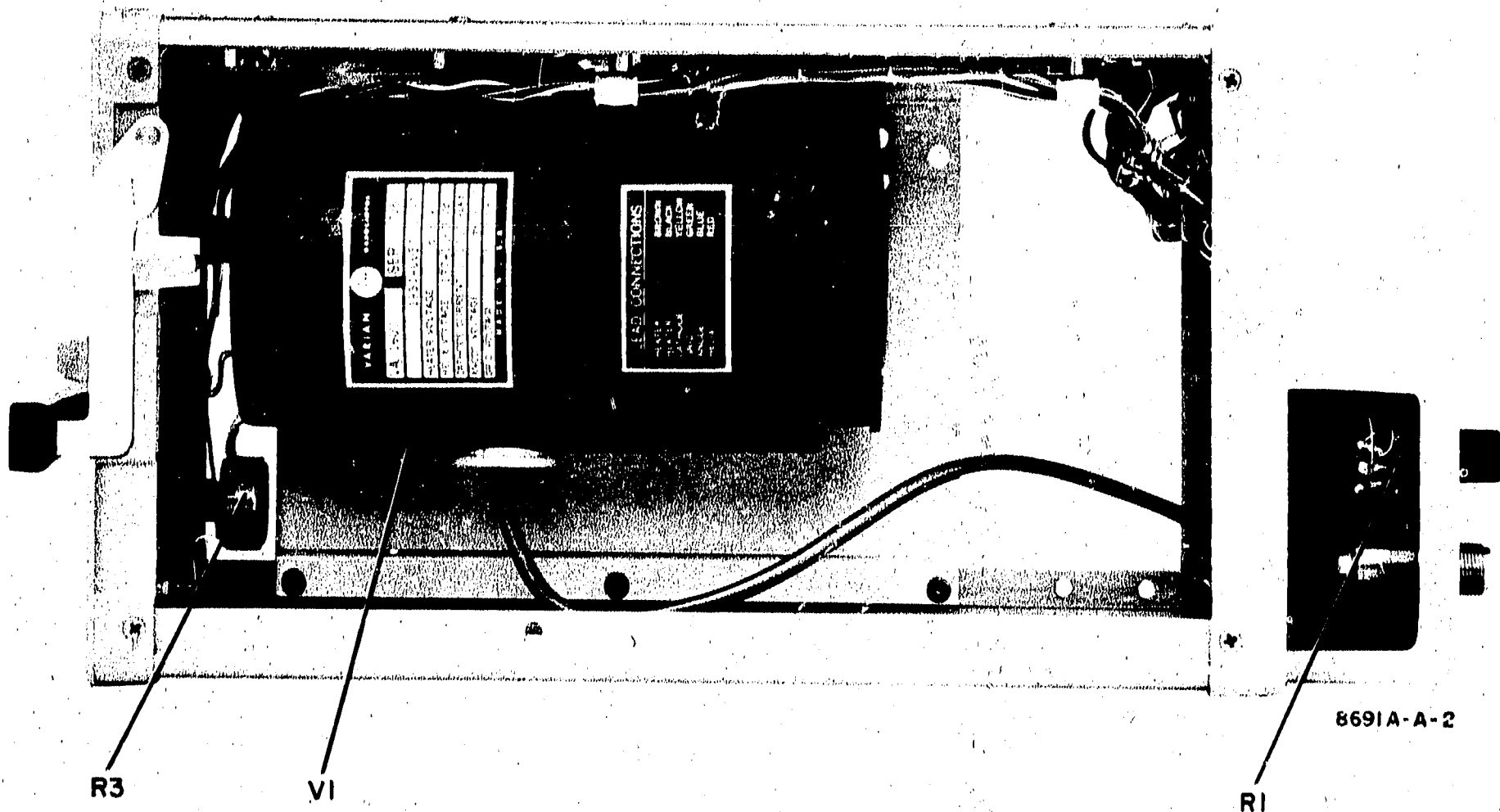
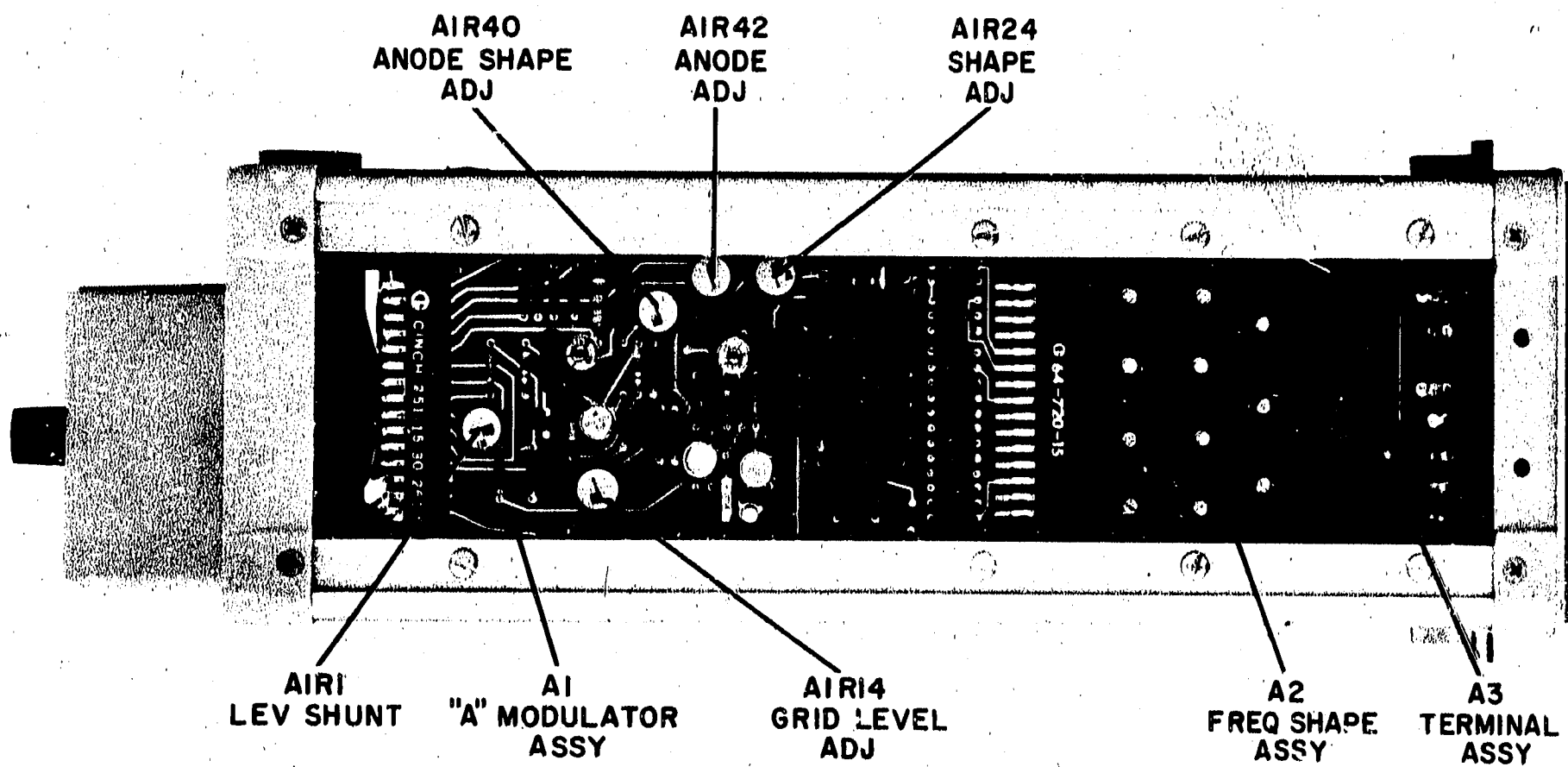

Figure 2-4. Component Identification, Interior Left Side



8691A-A-4

Figure 2-5. Component and Adjustment Identification, Interior Top View

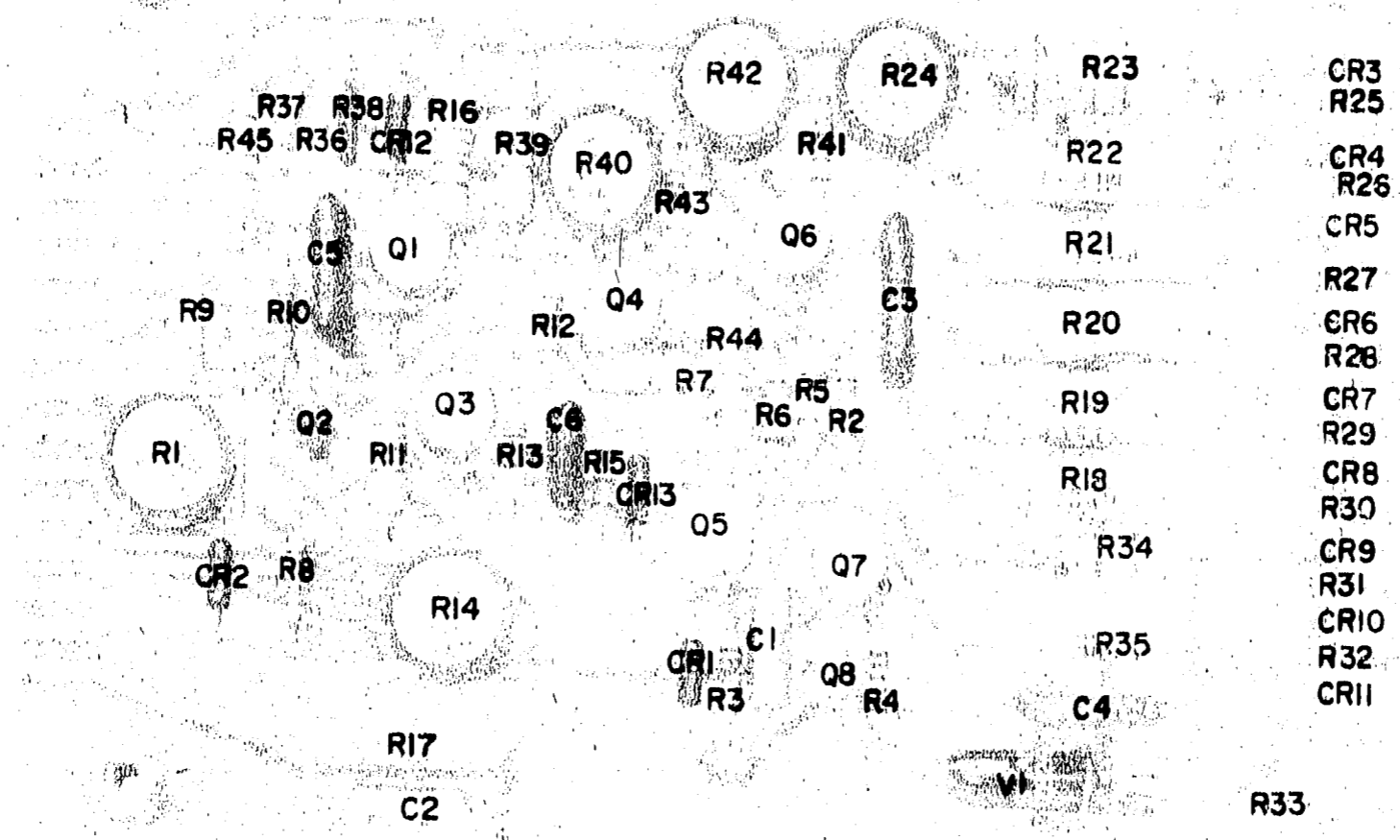
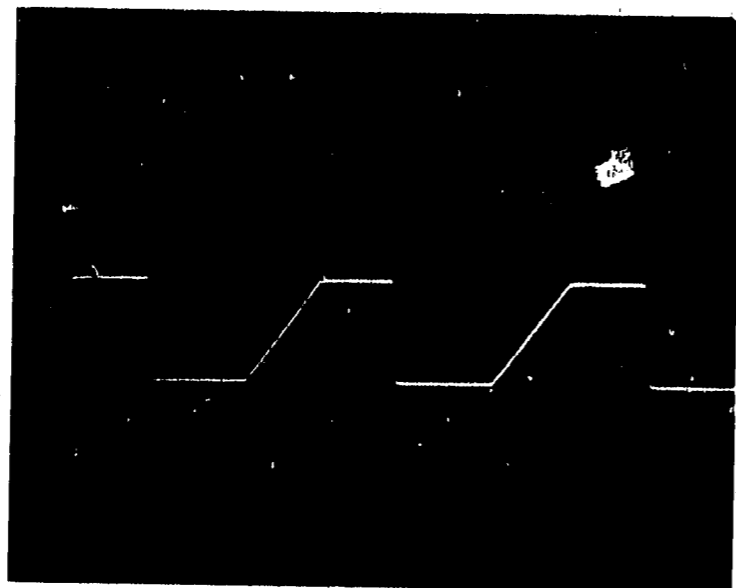

Figure 2-6. Component Identification Assembly A1



Junction A1R38, A1R39  
20 V/div 5 ms/div



Emitter A1Q1  
20 V/div 5 ms/div

Figure 2-7. Waveforms

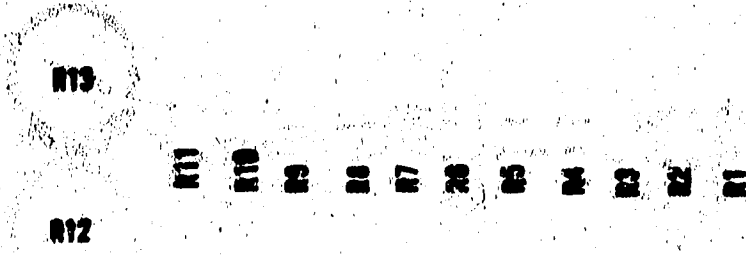

Assembly A2 (Standard Models)

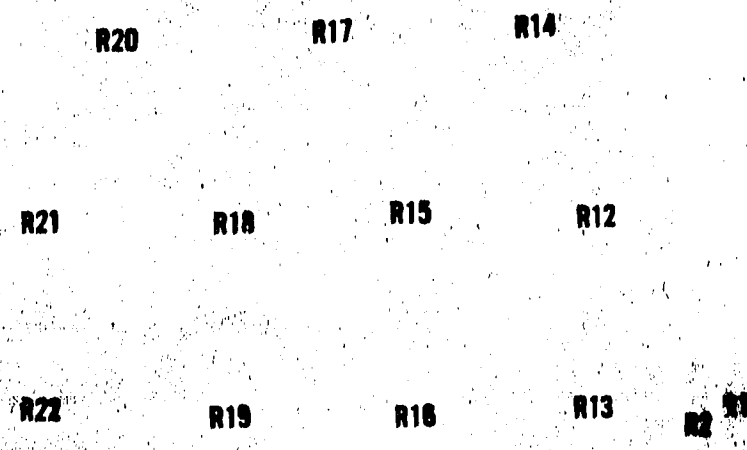

Assembly A2 (Special Models)

Figure 2-8. Component Identification, Assembly A2

# PARTS LIST

## SECTION III

## REPLACEABLE PARTS

## 3-1. INTRODUCTION.

3-2. This section contains information for ordering replacement parts. Table 3-1 lists parts in alpha-numerical order of their reference designators and indicates the description and hp stock number of each part, together with any applicable notes. Miscellaneous parts are listed at the end of Table 3-1. Table 3.2 lists parts in alpha-numerical order of their hp stock number and provides the following information on each part:

- Description.
- Manufacturer of the part in a five-digit code; see list of manufacturers in Table 3-3.
- Manufacturer's part number.
- Total quantity used (TQ column).

## 3-3. ORDERING INFORMATION.

3-4. To obtain replacement parts, address order or inquiry to your local Hewlett-Packard Field Office (see

list at rear of this manual for addresses). Identify parts by their Hewlett-Packard Stock numbers.

3-5. To obtain a part that is not listed, include:

- Instrument model number.
- Instrument serial number.
- Description of the part.
- Function and location of the part.

3-6. BWO tubes listed as alternate replacement for particular BWO tubes are not strictly interchangeable. Alternate BWO tubes require different helix voltage shaping resistance values on Freq. Shape Assembly A2. For this reason, order a BWO replacement tube only by the hp stock number printed on the label of the BWO tube to be replaced.

## REFERENCE DESIGNATORS

A	= assembly	E	= misc electronic part	P	= plug	V	= vacuum, tube, neon bulb, photocell, etc.
B	= motor	F	= fuse	Q	= transistor	VR	= voltage regulator
BT	= battery	FL	= filter	R	= resistor	W	= cable
C	= capacitor	J	= jack	RT	= thermistor	X	= socket
CP	= coupler	K	= relay	S	= switch	Y	= crystal
CR	= diode	L	= inductor	T	= transformer		
DL	= delay line	M	= meter	TB	= terminal board		
DS	= device signaling (lamp)	MP	= mechanical part	TP	= test point		

## ABBREVIATIONS

A	= amperes	H	= henries	NPN	= negative-positive-negative	RMS	= root-mean square
A. F. C.	= automatic frequency control	HEX	= hexagonal	NRFR	= not recommended for field replacement	RWV	= reverse working voltage
AMPL	= amplifier	HG	= mercury	NSR	= not separately replaceable	S-B	= slow-blow
B. F. O.	= beat frequency oscillator	HR	= hour(s)	OBD	= order by description	SCR	= screw
BE CU	= beryllium copper	IF	= intermediate freq	OH	= oval head	SE	= selenium
BH	= binder head	IMPG	= impregnated	OX	= oxide	SECT	= section(s)
BP	= bandpass	INCD	= incandescent	PH BRZ	= phosphor bronze	SEMICON	= semiconductor
BRS	= brass	INCL	= include(s)	PHL	= Phillips	SI	= silicon
BWO	= backward wave oscillator	INS	= insulation(ed)	PIV	= peak inverse voltage	SIL	= silver
CCW	= counter-clockwise	INT	= internal	PNP	= positive-negative-positive	SL	= slide
CER	= ceramic	K	= kilo = 1000	P/O	= part of	SPG	= spring
CMO	= cabinet mount only	LH	= left hand	POLY	= polystyrene	SPL	= special
COEF	= coefficient	LIN	= linear taper	PORC	= porcelain	SST	= stainless steel
COM	= common	LK WASH	= lock washer	POT	= potentiometer	SR	= split ring
COMP	= composition	LOG	= logarithmic taper	PP	= peak-to-peak	STL	= steel
COMPL	= complete	LP F	= low pass filter	PT	= point	TA	= tantalum
CONN	= connector	M	= milli = 10 <sup>-3</sup>	PWV	= peak working voltage	TD	= time delay
CP	= cadmium plate	MEG	= meg = 10 <sup>6</sup>	RECT	= rectifier	TGL	= toggle
CRT	= cathode-ray tube	MET FLM	= metal film	RF	= radio frequency	THD	= thread
CW	= clockwise	MET OX	= metallic oxide	RH	= round head or right hand	TI	= titanium
DEPC	= deposited carbon	MFR	= manufacturer	RMO	= rack mount only	TOL	= tolerance
DR	= drive	MINAT	= miniature			TRIM	= trimmer
ELECT	= electrolytic	MOM	= momentary			TWT	= traveling wave tube
ENCAP	= encapsulated	MTG	= mounting			U	= micro = 10 <sup>-6</sup>
EXT	= external	MY	= "mylar"			VAR	= variable
F	= farads	N	= nano (10 <sup>-9</sup> )			VDCW	= dc working volts
FH	= flat head	N/C	= normally closed			W/	= with
FIL H	= fillister head	NE	= neon			W	= watts
FXD	= fixed	NI PL	= nickel plate			WIV	= working inverse voltage
GE	= germanium	N/O	= normally open			WW	= wirewound
GL	= glass	NPO	= negative positive zero (zero temperature coefficient)			W/O	= without
GRD	= ground(ed)						

Table 3-1. Reference Designation Index

Reference Designation	Stock No.	Description #	Note
A1	08691-6102	ASSY:"A" MODULATOR	
A1C1	0180-0161	C:FXD ELECT 3.3 UF 20% 35VDCW	
A1C2	0180-0116	C:FXD ELECT 6.8 UF 10% 35VDCW	
A1C3	0160-0383	C:FXD MICA 10 PF 10% 2500VDCW	
A1C4	0150-0052	C:FXD CER 0.05 UF 20% 400VDCW	
A1C5	0160-2216	C:FXD MICA 820 PF 5%	
A1C6	0140-0199	C:FXD MICA 240 PF 5% 300VDCW	
A1CR1	1901-0033	DIODE:SILICON 1N485B	
A1CR2	1901-0033	DIODE:SILICON 1N485B	
A1CR3 THRU A1CR11	1901-0096	DIODE:SILICON 120V 3 PF	
A1CR12, CR13 A1CR14	1901-0033	DIODE:SILICON 1N485B	
A1CR15	1901-0026	NOT ASSIGNED	
A1Q1	1854-0232	DIODE:SILICON 0.75A 200PIV	
A1Q2	1853-0020	TRANSISTOR:SILICON NPN	
A1Q3	1853-0037	TRANSISTOR:SILICON PNP	
A1Q4	1854-0022	TRANSISTOR:SILICON PNP	
A1Q5	1851-0017	TRANSISTOR:SILICON NPN	
A1Q6	1854-0232	TRANSISTOR:SILICON NPN	
A1Q7	1854-0003	TRANSISTOR:SILICON NPN	
A1Q8	1853-0010	TRANSISTOR:SILICON PNP	
A1R1	2100-1773	R:VAR WW 1K OHM 10% LIN 1/2W	
A1R2	0698-3428	R:FXD MET FLM 14.7 OHM 1% 1/8W	
A1R3	0757-0430	R:FXD MET FLM 2.21K OHM 1% 1/8W	
A1R4	0757-0280	R:FXD MET FLM 1K OHM 1% 1/8W	
A1R5	0757-0442	R:FXD MET FLM 10K OHM 1% 1/8W	
A1R6	0698-3157	R:FXD MET FLM 19.6K OHM 1% 1/8W	
A1R7	0757-0454	R:FXD MET FLM 33.2K OHM 1% 1/8W	
A1R8	0757-0428	R:FXD MET FLM 1.62K OHM 1% 1/8W	
A1R9	0757-0199	R:FXD MET FLM 21.5K OHM 1% 1/8W	
A1R10	0757-0416	R:FXD MET FLM 511 OHM 1% 1/8W	
A1R11	0698-3175	R:FXD MET FLM 147K OHM 1% 1/2W	
A1R12	0757-0416	R:FXD MET FLM 511 OHM 1% 1/8W	
A1R13	0757-0442	R:FXD MET FLM 10K OHM 1% 1/8W	
A1R14	2100-0969	R:VAR COMP 50K OHM 20% LIN 1/2W	
A1R15	0698-3151	R:FXD MET FLM 2.87K OHM 1% 1/8W	
A1R16	0757-0063	R:FXD MET FLM 196K OHM 1% 1/2W	
A1R17	0757-0839	R:FXD MET FLM 10K OHM 1% 1/2W	
A1R18 THRU A1R22	0760-0023	R:FXD MET OX 150K OHM 1% 1W	
A1R23	0764-0007	R:FXD MET OX 27K OHM 5% 2W	
A1R24	2100-1775	R:VAR WW 5K OHM 10% LIN 1/2W	
A1R25 THRU A1R33	0757-0280	R:FXD MET FLM 1K OHM 1% 1/8W	
A1R34	0761-0032	R:FXD MET OX 56K OHM 5% 1W	
A1R35	0757-0401	R:FXD MET FLM 100 OHM 1% 1/8W	
A1R36	0698-3450	R:FXD MET FLM 42.2K OHM 1% 1/8W(8691A)	*
A1R36	0698-3450	R:FXD MET FLM 42.2K OHM 1% 1/8W(8692A)	*
A1R36	0698-3450	R:FXD MET FLM 42.2K OHM 1% 1/8W(8693A)	*
A1R36	0757-0463	R:FXD MET FLM 82.5K OHM 1% 1/8W(8694A)	*
A1R36	0757-0459	R:FXD MET FLM 56.2K OHM 1% 1/8W(H01-8694A)	*
A1R36	0757-0462	R:FXD MET FLM 75.0K OHM 1% 1/8W(H02-8694A)	*
* FACTORY SELECTED PART; TYPICAL VALUE GIVEN			

# See list of abbreviations in introduction to this section

Table 3-1. Reference Designation Index (Cont'd)

Reference Designation	Stock No.	Description #	Note
A1R37	0757-0459	R:FXD MET FLM 56.2K OHM 1% 1/8W 8691A(1.0-2.0 GHZ)	•
A1R37	0757-0459	R:FXD MET FLM 56.2K OHM 1% 1/8W 8692A(2.0-4.0 GHZ)	•
A1R37	0757-0459	R:FXD MET FLM 56.2K OHM 1% 1/8W 8693A(4.0-8.0 GHZ)	•
A1R37	0698-3161	R:FXD MET FLM 38.3K OHM 1% 1/8W 8694A(8.0-12.4 GHZ)	•
A1R37	0698-3162	R:FXD MET FLM 46.4K OHM 1% 1/8W H01-8694A(7.0-12.4GHZ)	•
A1R37	0698-3161	R:FXD MET FLM 38.3K OHM 1% 1/8W H02-8694A(7.0-11.0 GHZ)	•
A1R38	0757-0465	R:FXD MET FLM 100K OHM 1% 1/8W	
A1R39	0757-0137	R:FXD MET FLM 750K OHM 2% 1/2W	
A1R40	2100-0945	R:VAR MET FLM 500K OHM 20% TYPE H	
A1R41	0757-0463	R:FXD MET FLM 82.5K OHM 1% 1/8W	
A1R42	2100-0945	R:VAR MET FLM 500K OHM 20% TYPE H	
A1R43	0757-0458	R:FXD MET FLM 51.1K OHM 1% 1/8W	
A1R44	0757-0374	R:FXD MET FLM 485K OHM 1% 1/2W	
A1R45	0757-0063	R:FXD MET FLM 196K OHM 1% 1/2W	
A1V1	1940-0013	ELECTRON TUBE: 82.0 ± 1V	
A2	08691-6104	ASSY:FREQ SHAPE(8691A-8694A) SPECIAL MODELS	
A2R1	0757-0458	R:FXD MET FLM 51.1K OHM 1% 1/8W	
A2R2	0757-0458	R:FXD MET FLM 51.1K OHM 1% 1/8W	
A2R3 THRU A2R11		NOT ASSIGNED	
A2R12	2100-1418	R:VAR COMP 50K OHM 20% LIN 1/5W	•
A2R13	2100-0917	R:VAR COMP 500K OHM 20% LIN 1/5W	•
A2R14	2100-0918	R:VAR COMP 1 MEGOHM 20% LIN 1/5W	•
A2R15	2100-0918	R:VAR COMP 1 MEGOHM 20% LIN 1/5W	•
A2R16	2100-0918	R:VAR COMP 1 MEGOHM 20% LIN 1/5W	•
A2R17	2100-0918	R:VAR COMP 1 MEGOHM 20% LIN 1/5W	•
A2R18	2100-0918	R:VAR COMP 1 MEGOHM 20% LIN 1/5W	•
A2R19	2100-0918	R:VAR COMP 1 MEGOHM 20% LIN 1/5W	•
A2R20	2100-0918	R:VAR COMP 1 MEGOHM 20% LIN 1/5W	•
A2R21	2100-0918	R:VAR COMP 1 MEGOHM 20% LIN 1/5W	•
A2R22	2100-0918	R:VAR COMP 1 MEGOHM 20% LIN 1/5W	•
A2	08691-6103	ASSY:FREQ SHAPE(8691A) USED W/1951-0020 BWO	
A2R1 THRU A2R11		FACTORY SELECTED VALUE	•
A2R12	2100-1777	R:VAR COMP 20K OHM 10% LIN 1/2W	
A2R13	2100-0969	R:VAR COMP 50K OHM 20% LIN 1/2W	
A2	08692-6101	ASSY:FREQ SHAPE(8692A) USED W/1951-0064 BWO	
A2R1 THRU A2R13		FACTORY SELECTED VALUE	•
* FACTORY SELECTED PART; TYPICAL VALUE GIVEN			

# See list of abbreviations in introduction to this section



Table 3-1: Reference Designation Index (Cont' d)

Reference Designation	Stock No.	Description #	Note
A2	08692-6102	ASSY:FREQ SHAPE(8692A) USED W/1951-0055 ALT BWO	
A2R1 THRU A2R13		FACTORY SELECTED VALUE	*
A2	08693-6101	ASSY:FREQ SHAPE(8693A) USED W/1951-0065 ALT BWO	
A2R1 THRU A2R13		FACTORY SELECTED VALUE	*
A2	08693-6102	ASSY:FREQ SHAPE(8693A) USED W/1951-0057 BWO	
A2R1 THRU A2R13		FACTORY SELECTED VALUE	*
A2	08694-6101	ASSY:FREQ SHAPE(8694A) USED W/1951-0066 ALT BWO	
A2R1 THRU A2R13		FACTORY SELECTED VALUE	*
A2	08694-6102	ASSY:FREQ SHAPE(8694A) USED W/1951-0058 BWO	
A2R1 THRU A2R13		FACTORY SELECTED VALUE	*
A2	08694-6103	ASSY:FREQ SHAPE(M01-8694A) USED W/1951-0066 ALT BWO	
A2R1 THRU A2R13		FACTORY SELECTED VALUE	*
A2	08694-6104	ASSY:FREQ SHAPE(M01-8694A) USED W/1951-0058 BWO	
A2R1 THRU A2R13		FACTORY SELECTED VALUE	*
A2	08694-6105	ASSY:FREQ SHAPE(M02-8694A) USED W/1951-0066 ALT BWO	
A2R1 THRU A2R13		FACTORY SELECTED VALUE	*
A2	08694-6106	ASSY:FREQ SHAPE(M02-8694A) USED W/1951-0058 BWO	
A2R1 THRU A2R13		FACTORY SELECTED VALUE	*
A3	08691-6118	BOARD ASSY:BWO TERM	
* FACTORY SELECTED PART; TYPICAL VALUE GIVEN			

# See list of abbreviations in introduction to this section

Table 3-1. Reference Designation Index (Cont' d)

Reference Designation	Stock No.	Description #	Note
A4	08691-6110	DETECTOR:DIRECTIONAL(8691A, OPT 01)	
A4	08692-6110	DETECTOR:DIRECTIONAL(8692A, OPT 01)	
A4	08693-6110	DETECTOR:DIRECTIONAL(8693A, OPT 01)	
A5	1130-0032	COUPLER:DIRECTIONAL(8694A, OPT 01, H01-8694A, OPT 01, H02-8694A, OPT 01)	
A6	08694-6110	DETECTOR:CRYSTAL(8694A, OPT 01, H01-8694A, OPT 01, H02-8694A, OPT 01)	
CP1	1250-0777	ADAPTER:UG29(8694A, OPT 01, H01-8694A OPT 01, H02-8694A, OPT 01)	
DS1	2140-0092 1450-0152 1450-0153	LAMP:INCANDESCENT 60 MA 5V LENS:RED PLASTIC LAMPHOLDER:FOR T-1 SERIES	
FL1	3600 00694-604	FILTER:LOW PASS(8692A OPT 01) FILTER:LOW PASS(8694A OPT 01, H01-8694A OPT 01, H02-8694A OPT 01)	
J1	1250-0083	CONNECTOR:RF BNC	
R1 R2 R3	2100-2675 2100-0051	R:VAR COMP 2 SECT 1K OHM 20% LIN PART OF R1 R:VAR COMP 20K OHM 10% CWLOG 2W	
S1	3101-0957	SWITCH:DPDT(OPT 01)	
V1 V1 V1 V1 V1	1951-0020 1951-0064 1951-0057 1951-0058 1951-0066	ELECTRON TUBE:BWO(8691A) ELECTRON TUBE:BWO(8692A) ELECTRON TUBE:BWO(8693A) ELECTRON TUBE:BWO(8694A,H01-8694A,H02-8694A) ELECTRON TUBE:BWO(ALT FOR 1951-0058)	1 1 1 1
V1 V1	1951-0065 1951-0055	ELECTRON TUBE:BWO(ALT FOR 1951-0057) ELECTRON TUBE:BWO(ALT FOR 1951-0064)	1 1
W1 W1 W1 W1	08691-6003 08691-6003 08691-6003 08691-6003	CABLE ASSY:8691A OPT 01 CABLE ASSY:8692A OPT 01 CABLE ASSY:8693A OPT 01 CABLE ASSY:8694A OPT 01,H01-8694A OPT 01, H02-8694A OPT 01.	
		MISCELLANEOUS	
	0370-0133 3150-0054 08691-0100 08691-2003 08691-2110	KNOB:5/8" DIA 1/4" SHAFT FILTER:AIR PANEL:FRONT(8691A) HANDLE ASSY SCALE:1.0-2.0 GHZ(8691A)	
		* FACTORY SELECTED PART;TYPICAL VALUE GIVEN 1-REFER TO PARAGRAPH 3-6.	

# See list of abbreviations in introduction to this section

Table 3-1. Reference Designation Index (Cont'd)

Reference Designation	Stock No.	Description #	Note
	08691-2112	PANEL:REAR	
	08692-0100	PANEL:FRONT(8692A)	
	08692-2110	SCALE:2.0-4.0 GHZ(8692A)	
	08693-0100	PANEL:FRONT(8693A)	
	08693-2110	SCALE:4.0-8.0 GHZ(8693A)	
	08694-0100	PANEL:FRONT(8694A & OPT 01)	
	08694-0102	PANEL:FRONT(M01-8694A & OPT 01)	
	08694-0104	PANEL:FRONT(M02-8694A & OPT 01)	
	08694-2110	SCALE:8.0-12.4 GHZ(8694A & OPT 01)	
	08694-2111	SCALE:7.0-12.4 GHZ(M01-8694A & OPT 01)	
	08694-2112	SCALE:7.0-11.0 GHZ(M02-8694A & OPT 01)	

# See list of abbreviations in introduction to this section

Table 3-2. Replaceable Parts

Stock No.	Description #	Mfr.	Mfr. Part No.	TQ
0140-0199	C:FXD MICA 240 PF 5% 300VDCW	72136	DM15F241J	1
0150-0052	C:FXD CER 0.05 UF 20% 400VDCW	56289	33C17A	1
0160-0383	C:FXD MICA 10 PF 10% 2500VDCW	28480	0160-0383	1
0160-2216	C:FXD MICA 820 PF 5%	28480	0160-2216	1
0180-0116	C:FXD ELECT 6.8 UF 10% 35VDCW	56289	150D685X9035B2	1
0180-0161	C:FXD ELECT 3.3 UF 20% 35VDCW	56289	150D335X0035B2	1
360D	FILTER:LOW PASS(8692A OPT 01)	28480	360D	1
0370-0133	KNOB:5/8" DIA 1/4" SHAFT	28480	0370-0133	1
00694-604	FILTER:LOW PASS(8694A,H01,H02, OPT 01)	28480	00694-604	1
0698-3151	R:FXD MET FLM 2.87K OHM 1% 1/8W	28480	0698-3151	1
0698-3157	R:FXD MET FLM 19.6K OHM 1% 1/8W	28480	0698-3157	1
0698-3161	R:FXD MET FLM 38.3K OHM 1% 1/8W	28480	0698-3161	2
0698-3162	R:FXD MET FLM 46.4K OHM 1% 1/8W	28480	0698-3162	1
0698-3175	R:FXD MET FLM 147K OHM 1% 1/2W	28480	0698-3175	1
0698-3428	R:FXD MET FLM 14.7 OHM 1% 1/8W	28480	0698-3428	1
0698-3450	R:FXD MET FLM 42.2K OHM 1% 1/8W	28480	0698-3450	3
0757-0063	R:FXD MET FLM 196K OHM 1% 1/2W	28480	0757-0063	2
0757-0137	R:FXD MET FLM 750K OHM 2% 1/2W	28480	0757-0137	1
0757-0199	R:FXD MET FLM 21.5K OHM 1% 1/8W	28480	0757-0199	1
0757-0280	R:FXD MET FLM 1K OHM 1% 1/8W	28480	0757-0280	10
0757-0374	R:FXD MET FLM 485K OHM 1% 1/2W	28480	0757-0374	1
0757-0401	R:FXD MET FLM 100 OHM 1% 1/8W	28480	0757-0401	1
0757-0416	R:FXD MET FLM 511 OHM 1% 1/8W	28480	0757-0416	2
0757-0428	R:FXD MET FLM 1.62K OHM 1% 1/8W	28480	0757-0428	1
0757-0430	R:FXD MET FLM 2.21K OHM 1% 1/8W	28480	0757-0430	1
0757-0442	R:FXD MET FLM 10K OHM 1% 1/8W	28480	0757-0442	2
0757-0454	R:FXD MET FLM 33.2K OHM 1% 1/8W	28480	0757-0454	1
0757-0458	R:FXD MET FLM 51.1K OHM 1% 1/8W	28480	0757-0458	3
0757-0459	R:FXD MET FLM 56.2K OHM 1% 1/8W	28480	0757-0459	4
0757-0462	R:FXD MET FLM 75.0K OHM 1% 1/8W	28480	0757-0462	1
0757-0463	R:FXD MET FLM 82.5K OHM 1% 1/8W	28480	0757-0463	2
0757-0465	R:FXD MET FLM 100K OHM 1% 1/8W	28480	0757-0465	1
0757-0839	R:FXD MET FLM 10K OHM 1% 1/2W	28480	0757-0839	1
0760-0023	R:FXD MET OX 150K OHM 1% 1W	28480	0760-0023	5
0761-0032	R:FXD MET OX 56K OHM 5% 1W	28480	0761-0032	1
0764-0007	R:FXD MET OX 27K OHM 5% 2W	16229	C 42S	2
1130-0032	COUPLER:DIRECTIONAL	28480	1130-0032	1
1250-0083	CONNECTOR:RF BNC	28480	1250-0083	1
1250-0777	ADAPTER:UG29	28480	1250-0777	1
1450-0152	LENS:RED PLASTIC	08717	102XX-R	1
1450-0153	LAMPHOLDER FOR T-1 SERIES	08717	102SR	1
1851-0017	TRANSISTOR:2N1304	01295	2N1304	1
1853-0010	TRANSISTOR:SILICON PNP	28480	1853-0010	1
1853-0020	TRANSISTOR:SILICON PNP	28480	1853-0020	1
1853-0037	TRANSISTOR:SILICON PNP	28480	1853-0037	1
1854-0003	TRANSISTOR:SILICON NPN	28480	1854-0003	1
1854-0022	TRANSISTOR:SILICON NPN	28480	1854-0022	1
1854-0232	TRANSISTOR:SILICON NPN	28480	1854-0232	2
1901-0026	DIODE:SILICON 0.75A 200PIV	28480	1901-0026	1
1901-0033	DIODE:SILICON 1N485B	28480	1901-0033	5
1901-0096	DIODE:SILICON 120V 3PF	28480	1901-0096	9
1940-0013	ELECTRON TUBE 82.0±1V	74276	Z82R7	1
1951-0020	ELECTRON TUBE:BWO(8691A)			1

# See list of abbreviations in introduction to this section

Table 3-2. Replaceable Parts (Cont'd)

Stock No.	Description #	Mfr.	Mfr. Part No.	TQ
1951-0055	ELECTRON TUBE:8W0	28480	1951-0055	1
1951-0057	ELECTRON TUBE:8W0(8693A)	28480	1951-0057	1
1951-0058	ELECTRON TUBE:8W0(8694A)	28480	1951-0058	1
1951-0064	ELECTRON TUBE:8W0(8692A)	28480	1951-0064	1
1951-0065	ELECTRON TUBE:8W0	28480	1951-0065	1
1951-0066	ELECTRON TUBE:8W0	28480	1951-0066	1
2100-0051	R:VAR COMP 20K OHM 10% CWLOG 2W	28480	2100-0051	1
2100-0917	R:VAR COMP 500K OHM 20% LIN 1/5W	28480	2100-0917	1
2100-0918	R:VAR COMP 1 MEGOHM 20% LIN 1/5W	28480	2100-0918	9
2100-0945	R:VAR MET FLM 500K OHM 20% TYPE H	28480	2100-0945	2
2100-0969	R:VAR COMP 50K OHM 20% LIN 1/2W	28480	2100-0969	2
2100-1418	R:VAR COMP 50K OHM 20% LIN 1/5W	28480	2100-1418	1
2100-1773	R:VAR WW 1K OHM 10% LIN 1/2W	28480	2100-1773	1
2100-1775	R:VAR WW 5K OHM 10% LIN 1/2W	28480	2100-1775	1
2100-1777	R:VAR COMP 20K OHM 10% LIN 1/2W	28480	2100-1777	1
2100-2675	R:VAR COMP 1K OHM 20% LIN(2 SECT)	28480	2100-2675	1
2140-0092	LAMP:INCANDESCENT 60 MA 5V	71744	CM8-685	1
3101-0957	SWITCH:DPDT	88140	8909K310	1
3150-0054	FILTER:AIR	28480	3150-0054	1
08691-0100	PANEL:FRONT(8691A)	28480	08691-0100	1
08691-2003	HANDLE ASSY	28480	08691-2003	1
08691-2110	SCALE:1.0-2.0 GHZ(8691A)	28480	08691-2110	1
08691-2112	PANEL:REAR	28480	08691-2112	1
08691-6003	CABLE ASSY(8691A,8692A,8693A,8694A)	28480	08691-6003	4
08691-6102	ASSY:"A" MODULATOR	28480	08691-6102	1
08691-6103	ASSY:FREQ SHAPE(8691A)	28480	08691-6103	1
08691-6104	ASSY:FREQ SHAPE(8691A)	28480	08691-6104	1
08691-6118	BOARD ASSY:8W0 TERM	28480	08691-6118	1
08691-6110	DETECTOR:DIRECTIONAL(8691A OPT 01)	28480	08691-6110	1
08692-0100	PANEL:FRONT(8692A)	28480	08692-0100	1
08692-2110	SCALE:2.0-4.0 GHZ(8692A)	28480	08692-2110	1
08692-6101	ASSY:FREQ SHAPE(8692A)	28480	08692-6101	1
08692-6102	ASSY:FREQ SHAPE(8692A)	28480	08692-6102	1
08692-6110	DETECTOR:DIRECTIONAL(8692A OPT 01)	28480	08692-6110	1
08693-0100	PANEL:FRONT(8693A)	28480	08693-0100	1
08693-2110	SCALE:4.0-8.0 GHZ(8693A)	28480	08693-2110	1
08693-6101	ASSY:FREQ SHAPE(8693A)	28480	08693-6101	1
08693-6102	ASSY:FREQ SHAPE(8693A)	28480	08693-6102	1
08693-6110	DETECTOR:DIRECTIONAL(8693A OPT 01)	28480	08693-6110	1
08694-0100	PANEL:FRONT(8694A & OPT 01)	28480	08694-0100	1
08694-0102	PANEL:FRONT(H01-8694A & OPT 01)	28480	08694-0102	1
08694-0104	PANEL:FRONT(H02-8694A & OPT 01)	28480	08694-0104	1
08694-2110	SCALE:8.0-12.4 GHZ(8694A & OPT 01)	28480	08694-2110	1
08694-2111	SCALE:7.0-12.4 GHZ(H01-8694A & OPT 01)	28480	08694-2111	1
08694-2112	SCALE:7.0-11.0 GHZ(H02-8694A & OPT 01)	28480	08694-2112	1
08694-6101	ASSY:FREQ SHAPE(8694A)	28480	08694-6101	1
08694-6102	ASSY:FREQ SHAPE(8694A)	28480	08694-6102	1
08694-6103	ASSY:FREQ SHAPE(H01-8694A)	28480	08694-6103	1
08694-6104	ASSY:FREQ SHAPE(H01-8694A)	28480	08694-6104	1
08694-6105	ASSY:FREQ SHAPE(H02-8694A)	28480	08694-6105	1
08694-6106	ASSY:FREQ SHAPE(H02-8694A)	28480	08694-6106	1
08694-6110	DETECTOR:CRYSTAL(8694A,H01,H02, OPT 01)	28480	08694-6110	1

# See list of abbreviations in introduction to this section

**TABLE 6-3.**  
**CODE LIST OF MANUFACTURERS**

The following code numbers are from the Federal Supply Code for Manufacturers Cataloging Handbooks H4-1 (Name to Code) and H4-2 (Code to Name) and their latest supplements. The date of revision and the date of the supplements used appear at the bottom of each page. Alphabetical codes have been arbitrarily assigned to suppliers not appearing in the H4 Handbooks.

Code No.	Manufacturer	Address	Code No.	Manufacturer	Address	Code No.	Manufacturer	Address
00000	U. S. A. Common	Any supplier of U. S.	05277	Westinghouse Electric Corp.	Youngwood, Pa.	09250	Electro Assemblies, Inc.	Chicago, Ill.
00136	McCoy Electronics	Mount Holly Springs, Pa.		Semi-Conductor Dept.	San Mateo, Calif.	09353	C & K Components Inc.	Newton, Mass.
00213	Sage Electronics Corp.	Rochester, N. Y.	05347	Ultronix, Inc.	New York, N. Y.	09569	Mallory Battery Co. of	Toronto, Ontario, Canada
00287	Cemco Inc.	Danielson, Conn.	05397	Union Carbide Corp., Elect. Div.	Canoga Park, Calif.		Burndy Corp.	Norwalk, Conn.
00334	Humidial	Colton, Calif.			Sunnyvale, Calif.	09922	General Transistor Western Corp.	Los Angeles, Calif.
00348	Microtron Co., Inc.	Valley Stream, N. Y.	05574	Viking Ind. Inc.	Sunnyvale, Calif.	10214	Ti-Tal, Inc.	Berkeley, Calif.
00373	Garlock Inc.	Cherry Hill, N. J.	05593	Icore Electro-Plastics Inc.	Cleveland, Ohio	10646	Carborundum Co.	Niagara Falls, N. Y.
00656	Aerovox Corp.	New Bedford, Mass.	05616	Cosmo Plastic	Rockford, Ill.	11236	CTS of Berne, Inc.	Berne, Ind.
00779	Amp. Inc.	Harrisburg, Pa.	05624	Barber Colman Co.	Roslyn Heights, Long Island, N. Y.	11237	Chicago Telephone of California, Inc.	So. Pasadena, Calif.
00781	Aircraft Radio Corp.	Boonton, N. J.	05728	Tiffen Optical Co.	Westbury, N. Y.	11242	Bay State Electronics Corp.	Waltham, Mass.
00815	Northern Engineering Laboratories, Inc.	Burlington, Wis.	05729	Metro-Tel Corp.	Santa Cruz, Calif.	11312	Teledyne Inc., Microwave Div.	Palo Alto, Calif.
00853	Sangamo Electric Co., Pickens Div.	Pickens, S. C.	05783	Stewart Engineering Co.	Wakefield, Mass.	11314	National Seal	Downey, Calif.
00866	Goe Engineering Co.	City of Industry, Cal.	05820	Wakefield Engineering Inc.	Bridgeport, Conn.	11453	Precision Connector Corp.	Jamaica, N. Y.
00891	Carl E. Holmes Corp.	Los Angeles, Calif.	06004	Bassick Co., Div. of Stewart Warner Corp.	Redwood City, Calif.	11534	Duncan Electronics Inc.	Costa Mesa, Calif.
00929	Microfab Inc.	Livingston, N. J.	06090	Raychem Corp.	Rochester, N. Y.	11711	General Instrument Corp., Semiconductor	Newark, N. J.
01002	General Electric Co., Capacitor Dept.	Hudson Falls, N. Y.	06175	Bausch and Lomb Optical Co.	Chicago, Ill.	11717	Imperial Electronic, Inc.	Buena Park, Calif.
01009	Alden Products Co.	Brockton, Mass.	06402	E. T. A. Products Co. of America	New Rochelle, N. Y.	11870	Melabs, Inc.	Palo Alto, Calif.
01121	Allen Bradley Co.	Milwaukee, Wis.	06540	Amatom Electronic Hardware Co., Inc.	Penacook, N. H.	12136	Philadelphia Handle Co.	Camden, N. J.
01255	Litton Industries, Inc.	Beverly Hills, Calif.	06555	Beede Electrical Instrument Co., Inc.	Indianapolis, Ind.	12361	Grove Mfg. Co., Inc.	Shady Grove, Pa.
01281	TRW Semiconductors, Inc.	Lawndale, Calif.	06666	General Devices Co., Inc.	Phoenix, Ariz.	12574	Gulton Ind. Inc. Data System Div.	Albuquerque, N. M.
01295	Texas Instruments, Inc., Transistor Products Div.	Dallas, Texas	06751	Components Inc., Ariz. Div.	Phoenix, Ariz.	12697	Clarostat Mfg. Co.	Dover, N. H.
01349	The Alliance Mfg. Co.	Alliance, Ohio	06812	Torrington Mfg. Co., West Div.	Van Nuys, Calif.	12728	Elmar Filter Corp.	W. Haven, Conn.
01589	Pacific Relays, Inc.	Van Nuys, Calif.	06980	Varian Assoc. Eimac Div.	San Carlos, Calif.	12859	Nippon Electric Co., Ltd.	Tokyo, Japan
01670	Gudebrod Bros. Silk Co.	New York, N. Y.	07088	Kelvin Electric Co.	Van Nuys, Calif.	12881	Metex Electronics Corp.	Clark, N. J.
01930	Amerock Corp.	Rockford, Ill.	07126	Digitran Co.	Pasadena, Calif.	12930	Delta Semiconductor Inc.	Newport Beach, Calif.
01961	Pulse Engineering Co.	Santa Clara, Calif.	07138	Westinghouse Electric Corp. Electronic Tube Div.	Minneapolis, Minn.	12954	Dickson Electronics Corp.	Scottsdale, Arizona
02114	Ferroxcube Corp. of America	Saugerties, N. Y.	07149	Filmohm Corp.	Elmira, N. Y.	13103	Thermolloy	Dallas, Texas
02116	Wheelock Signals, Inc.	Long Branch, N. J.	07233	Cinch-Graphik Co.	New York, N. Y.	13396	Telefunken (GmbH)	Hanover, Germany
02286	Cole Rubber and Plastics Inc.	Sunnyvale, Calif.	07256	Silicon Transistor Corp.	City of Industry, Calif.	13835	Midland-Wright Div. of Pacific Industries, Inc.	Kansas City, Kansas
02660	Amphenol-Borg Electronics Corp.	Broadview, Ill.	07261	Avnet Corp.	Carle Place, N. Y.	14099	Sem-Tech	Newbury Park, Calif.
02735	Radio Corp. of America, Semiconductor and Materials Div.	Somerville, N. J.	07263	Fairchild Camera & Inst. Corp. Semiconductor Div.	Culver City, Calif.	14193	Calif. Resistor Corp.	Santa Monica, Calif.
02771	Vocaline Co. of America, Inc.	Old Saybrook, Conn.	07263	Fairchild Camera & Inst. Corp. Semiconductor Div.	Culver City, Calif.	14298	American Components, Inc.	Conshohocken, Pa.
02777	Hopkins Engineering Co.	San Fernando, Calif.	07322	Minnesota Rubber Co.	Mountain View, Calif.	14433	ITT Semiconductor, A Div. of Int. Telephone & Telegraph Corp.	West Palm Beach, Fla.
02875	Hudson Tool & Die	Newark, N. J.	07387	Birtcher Corp., The	Mountain View, Calif.	14493	Hewlett-Packard Company	Loveland, Colo.
03508	G. E. Semiconductor Prod. Dept.	Syracuse, N. Y.	07397	Sylvania Elect. Prod. Inc., MT. View Operations	Cranford, N. J.	14655	Cornell Jublier Electric Corp.	Newark, N. J.
03705	Apex Machine & Tool Co.	Dayton, Ohio	07700	Technical Wire Products Inc.	Cranford, N. J.	14674	Corning Glass Works	Corning, N. Y.
03797	Eldema Corp.	Compton, Calif.	07829	Bodine Elect. Co.	Chicago, Ill.	14752	Electro Cube Inc.	San Gabriel, Calif.
03818	Parker Seal Co.	Los Angeles, Calif.	07910	Continental Device Corp.	Hawthorne, Calif.	14960	Williams Mfg. Co.	San Jose, Calif.
03877	Transitron Electric Corp.	Wakefield, Mass.	07933	Raytheon Mfg. Co. Semiconductor Div.	Mountain View, Calif.	15203	Webster Electronics Co.	New York, N. Y.
03888	Pyrofilm Resistor Co., Inc.	Cedar Knolls, N. J.	07980	Hewlett-Packard Co., Boonton Radio Div.	Boonton Radio Div.	15287	Scionics Corp.	Northridge, Calif.
03954	Singer Co., Diehl Div.	Sumerville, N. J.	08145	U. S. Engineering Co.	Rockaway, N. J.	15291	Adjustable Bushing Co.	N. Hollywood, Calif.
04009	Arrow, Hart and Hegeman Elect. Co.	Hartford, Conn.	08289	Blian, Delbert Co.	Los Angeles, Calif.	15558	Micron Electronics	Garden City, Long Island, N. Y.
04013	Taurus Corp.	Lambertville, N. J.	08358	Burgess Battery Co.	Pomona, Calif.	15566	Amprobe Inst. Corp.	Lynbrook, N. Y.
04062	Arco Electronic Inc.	Great Neck, N. Y.	08524	Deutsch Fastener Corp.	Los Angeles, Calif.	15631	Cabletronics	Costa Mesa, Calif.
04222	Hi-Q Division of Aerovox	Myrtle Beach, S. C.	08664	Bristol Co., The	Niagara Falls, Ontario, Canada	15772	Twentieth Century Coil Spring Co.	Santa Clara, Calif.
04354	Precision Paper Tube Co.	Wheeling, Ill.	08717	Sloan Company	Los Angeles, Calif.	15801	Fenwal Elect. Inc.	Framingham, Mass.
04404	Dymec Division of Hewlett-Packard Co.	Palo Alto, Calif.	08718	ITT Cannon Electric Inc., Phoenix Div.	Waterbury, Conn.	15818	Amelco Inc.	Mt. View, Calif.
04651	Sylvania Electric Products, Microwave Device Div.	Mountain View, Calif.	08727	National Radio Lab, Inc.	Sun Valley, Calif.	16037	Spruce Pine Mica Co.	Spruce Pine, N. C.
04673	Dakota Engr. Inc.	Culver City, Calif.	08792	CBS Electronics Semiconductor Operations, Div. of C. B. S. Inc.	Phoenix, Arizona	16179	Omni-Spectra Inc.	Detroit, Ill.
04713	Motorola, Inc., Semiconductor Prod. Div.	Phoenix, Arizona	08806	General Electric Co. Miniat. Lamp Dept.	Lowell, Mass.	16352	Computer Diode Corp.	Lodi, N. J.
04732	Filtron Co., Inc. Western Div.	Culver City, Calif.	08984	Mel-Rain	Cleveland, Ohio	16585	Boots Aircraft Nut Corp.	Pasadena, Calif.
04773	Automatic Electric Co.	Northlake, Ill.	09026	Babcock Relays Div.	Indianapolis, Ind.	16688	Ideal Prec. Meter Co., Inc. De Jur Meter Div.	Brooklyn, N. Y.
04796	Sequoia Wire Co.	Redwood City, Calif.	09134	Texas Capacitor Co.	Costa Mesa, Calif.	16758	Delco Radio Div. of G. M. Corp.	Kokoma, Ind.
04811	Precision Coil Spring Co.	El Monte, Calif.	09145	Tech. Ind. Inc. Atom Elect.	Houston, Texas	17109	Thermonetics Inc.	Canoga Park, Calif.
04870	P. M. Motor Company	Westchester, Ill.			Burbank, Calif.	17474	Tranex Company	Mountain View, Calif.
04919	Component Mfg. Service Co.	W. Bridgewater, Mass.				17675	Hamlin Metal Products Corp.	Akron, Ohio
05006	Twentieth Century Plastics, Inc.	Los Angeles, Calif.				17745	Angstrom Prec. Inc.	No. Hollywood, Calif.
						17870	McGraw-Edison Co.	Manchester, N. H.
						18042	Power Design Pacific Inc.	Palo Alto, Calif.
						18083	Clevite Corp., Semiconductor Div.	Palo Alto, Calif.

00015-46  
Revised: August, 1968

02334-2

From: FSC. Handbook Supplements  
H4-1 Dated AUGUST 1966

TABLE 6-3.  
CODE LIST OF MANUFACTURERS (Cont'd)

Code No.	Manufacturer	Address	Code No.	Manufacturer	Address	Code No.	Manufacturer	Address
18324	Signetics Corp.	Sunnyvale, Calif.	70276	Allea Mfg. Co.	Hartford, Conn.	74970	E. F. Johnson Co.	Waseca, Minn.
16476	Ty-Car Mfg. Co., Inc.	Holliston, Mass.	70309	Allied Control	New York, N. Y.	75042	International Resistance Co.	Philadelphia, Pa.
18486	TRW Elect. Comp. Div.	Des Plaines, Ill.	70318	Allmetal Screw Product Co., Inc.	Garden City, N. Y.	75263	Keystone Carbon Co., Inc.	St. Marys, Pa.
18583	Curtis Instrument, Inc.	Mt. Kisco, N. Y.	70417	Amplex, Div. of Chrysler Corp.	Detroit, Mich.	75378	CTS Knights Inc.	Sandwich, Ill.
18612	Vishay Instruments Inc.	Malvern, Pa.	70485	Atlantic India Rubber Works, Inc.	Chicago, Ill.	75382	Kulka Electric Corporation	Mt. Vernon, N. Y.
18873	E. I. DuPont and Co., Inc.	Wilmington, Del.	70563	Amperite Co., Inc.	Union City, N. J.	75818	Lenz Electric Mfg. Co.	Chicago, Ill.
18911	Durant Mfg. Co.	Milwaukee, Wis.	70674	ABC Products Inc.	Minneapolis, Minn.	75915	Littlefuse, Inc.	Des Plaines, Ill.
19315	The Bendix Corp., Navigation & Control Div.	Teterboro, N. J.	70903	Belden Mfg. Co.	Chicago, Ill.	76005	Lord Mfg. Co.	Erie, Pa.
19500	Thomas A. Edison Industries, Div. of McGraw-Edison Co.	Wrt Orange, N. J.	70998	Bird Electronic Corp.	Cleveland, Ohio	76210	C. W. Marwedel	San Francisco, Calif.
19589	Concoa	Baldwin Park, Calif.	71002	Birnbach Radio Co.	New York, N. Y.	76433	General Instrument Corp., Micamold Division	Newark, N. J.
19644	LRC Electronics	Horseheads, N. Y.	71034	Bliley Electric Co., Inc.	Erie, Pa.	76487	James Millen Mfg. Co., Inc.	Malden, Mass.
19701	Electra Mfg. Co.	Independence, Kansas	71041	Boston Gear Works Div. of Murray Co. of Texas	Quincy, Mass.	76493	J. W. Miller Co.	Los Angeles, Calif.
20183	General Atomics Corp.	Philadelphia, Pa.	71218	Bud Radio, Inc.	Willoughby, Ohio	76530	Cinch-Monadnock, Div. of United Carr Fastener Corp.	San Leandro, Calif.
21226	Executone, Inc.	Long Island City, N. Y.	71279	Cambridge Thermionics Corp.	Cambridge, Mass.	76545	Mueller Electric Co.	Cleveland, Ohio
21335	Fafnir Bearing Co., The	New Britain, Conn.	71286	Camloc Fastener Corp.	Paramus, N. J.	76703	National Union	Newark, N. J.
21520	Fansteel Metallurgical Corp.	N. Chicago, Ill.	71313	Cardwell Condenser Corp.	Lindenhurst L. I., N. Y.	76854	Oak Manufacturing Co.	Crystal Lake, Ill.
23042	Texscan Corp.	Indianapolis, Ind.	71400	Bussmann Mfg. Div. of McGraw-Edison Co.	St. Louis, Mo.	77075	Pacific Metals Co.	N. Hollywood, Calif.
23783	British Radio Electronics Ltd.	Washington, D. C.	71436	Chicago Condenser Corp.	Chicago, Ill.	77221	Phanostran Instrument and Electronic Co.	San Francisco, Calif.
24455	G. E. Lamp Division	Nela Park, Cleveland, Ohio	71447	Calif. Spring Co., Inc.	Pico-Rivera, Calif.	77252	Philadelphia Steel and Wire Corp.	Philadelphia, Pa.
24655	General Radio Co.	West Concord, Mass.	71450	CTS Corp.	Elkhart, Ind.	77342	American Machine & Foundry Co. Potter & Brunfield Div.	Princeton, Ind.
24681	Memcor Inc., Comp. Div.	Huntington, Ind.	71468	ITT Cannon Electric Inc.	Los Angeles, Calif.	77630	TRW Electronic Components Div.	Camden, N. J.
26365	Gries Reproducer Corp.	New Rochelle, N. Y.	71471	Cinema, Div. Aerovox Corp.	Burbank, Calif.	77638	General Instrument Corp., Rectifier Div.	Brooklyn, N. Y.
26462	Grobet File Co. of America, Inc.	Carlstadt, N. J.	71482	C. P. Clare & Co.	Chicago, Ill.	77764	Resistance Products Co.	Harrisburg, Pa.
26851	Compac/Hollister Co.	Hollister, Calif.	71590	Centralab Div. of Globe Union Inc.	Milwaukee, Wis.	77969	Rubbercraft Corp. of Calif.	Torrance, Calif.
26992	Hamilton Watch Co.	Lancaster, Pa.	71616	Commercial Plastics Co.	Chicago, Ill.	78189	Shakeproof Division of Illinois Tool Works	Elgin, Ill.
28486	Hewlett-Packard Co.	Palo Alto, Calif.	71700	Cornish Wire Co., The	New York, N. Y.	78277	Sigma	So. Braintree, Mass.
28520	Heyman Mfg. Co.	Kenilworth, N. J.	71707	Colo Coil Co., Inc.	Providence, R. I.	78283	Signal Indicator Corp.	New York, N. Y.
30817	Instrument Specialties Co., Inc.	Little Falls, N. J.	71744	Chicago Miniature Lamp Works	Chicago, Ill.	78290	Struthers-Dunn Inc.	Pitman, N. J.
33173	G. E. Receiving Tube Dept.	Owensboro, Ky.	71785	Cinch Mfg. Co., Howard B. Jones Div.	Chicago, Ill.	78452	Thompson-Bremer & Co.	Chicago, Ill.
35434	Lectrohm Inc.	Chicago, Ill.	71984	Dow Corning Corp.	Midland, Mich.	78471	Tilley Mfg. Co.	San Francisco, Calif.
36196	Stanwyck Coil Products Ltd.	Hawkesbury, Ontario, Canada	72136	Electro Motive Mfg. Co., Inc.	Willimantic, Conn.	78488	Stackpole Carbon Co.	St. Marys, Pa.
36287	Cunningham, W. H. & Hill, Ltd.	Toronto Ontario, Canada	72619	Dialight Corp.	Brooklyn, N. Y.	78493	Standard Thomson Corp.	Waltham, Mass.
37942	P. R. Mallory & Co. Inc.	Indianapolis, Ind.	72656	Indiana General Corp., Electronics Div.	Keasby, N. J.	78553	Tinnerman Products, Inc.	Cleveland, Ohio
39543	Mechanical Industries Prod. Co.	Akron, Ohio	72699	General Instrument Corp., Cap. Div.	Newark, N. J.	78790	Transformer Engineers	San Gabriel, Calif.
40920	Miniature Precision Bearings, Inc.	Keene, N. H.	72765	Drake Mfg. Co.	Harwood Heights, Ill.	78947	Ucinite Co.	Newtonville, Mass.
42190	Muter Co.	Chicago, Ill.	72825	Hugh H. Eby Inc.	Philadelphia, Pa.	79136	Walde Robinson Inc.	Long Island City, N. Y.
43990	C. A. Norgren Co.	Englewood, Colo.	72928	Gudeman Co.	Chicago, Ill.	79142	Veeder Root, Inc.	Hartford, Conn.
44655	Ohmite Mfg. Co.	Skokie, Ill.	72962	Elastic Stop Nut Corp.	Union, N. J.	79251	Wenco Mfg. Co.	Chicago, Ill.
46384	Penn Eng. & Mfg. Corp.	Doylstown, Pa.	72964	Robert M. Hadley Co.	Los Angeles, Calif.	79727	Continental-Wirt Electronics Corp.	Philadelphia, Pa.
47904	Polaroid Corp.	Cambridge, Mass.	72982	Erie Technological Products, Inc.	Erie, Pa.	79963	Zierick Mfg. Corp.	New Rochelle, N. Y.
48620	Precision Thermometer & Inst. Co.	Southampton, Pa.	73061	Hansen Mfg. Co., Inc.	Princeton, Ind.	80031	Mepco Division of Sessions Clock Co.	Morristown, N. J.
49956	Microwave & Power Tube Div.	Waltham, Mass.	73076	H. M. Harper Co.	Chicago, Ill.	80120	Schnitzer Alloy Products Co.	Elizabeth, N. J.
52090	Rowan Controller Co.	Westminster, Md.	73138	Helipal Div. of Beckman Inst., Inc.	Fullerton, Calif.	80131	Electronic Industries Association.	Any brand
52983	Sanborn Company	Waltham, Mass.	73293	Hughes Products Division of Hughes Aircraft Co.	Newport Beach, Calif.	80207	Tube meeting EIA Standards-Washington, DC.	Unimax Switch, Div. Maxon Electronics Corp.
54294	Shallcross Mfg. Co.	Selma, N. C.	73445	Amperox Elect Co.	Hicksville, L. I., N. Y.	80223	United Transformer Corp.	Wallingford, Conn.
55026	Simpson Electric Co.	Chicago, Ill.	73506	Bradley Semiconductor Corp.	New Haven, Conn.	80248	Oxford Electric Corp.	New York, N. Y.
55933	Sonotone Corp.	Elmsford, N. Y.	73559	Carling Electric, Inc.	Hartford, Conn.	80294	Bourns Inc.	Chicago, Ill.
55938	Raytheon Co. Commercial Apparatus & Systems Div.	So. Norwalk, Conn.	73586	Circle F Mfg. Co.	Trenton, N. J.	80411	Acro Div. of Robertshaw Controls Co.	Riverside, Calif.
56137	Spaulding Fibre Co., Inc.	Tonawanda, N. Y.	73682	George K. Garrett Co., Div. MSL Industries Inc.	Philadelphia, Pa.	80486	All Star Products Inc.	Columbus, Ohio
56289	Sprague Electric Co.	North Adams, Mass.	73734	Federal Screw Products Inc.	Chicago, Ill.	80509	Avery Label Co.	Defiance, Ohio
59446	Telex Corp.	Tulsa, Okla.	73743	Fischer Special Mfg. Co.	Cincinnati, Ohio	80583	Hammarlund Co., Inc.	Monrovia, Calif.
59730	Thomas & Betts Co.	Elizabeth, N. J.	73793	General Industries Co., The	Elyria, Ohio	80640	Stevens, Arnold, Co., Inc.	Mars Hill, N. C.
60741	Triplet Electrical Inst. Co.	Bluffton, Ohio	73846	Goshen Stamping & Tool Co.	Goshen, Ind.	80813	Dimco Gray Co.	Boston, Mass.
61775	Union Switch and Signal, Div. of Westinghouse Air Brake Co.	Pittsburgh, Pa.	73899	JFD Electronics Corp.	Brooklyn, N. Y.	81030	International Instruments Inc.	Dayton, Ohio
62119	Universal Electric Co.	Owosso, Mich.	73905	Jennings Radio Mfg. Corp.	San Jose, Calif.	81073	Grayhill Co.	Orange, Conn.
63743	Ward-Leonard Electric Co.	Mt. Vernon, N. Y.	73957	Groov-Pin Corp.	Ridgefield, N. J.	81095	Triad Transformer Corp.	LaGrange, Ill.
64959	Western Electric Co., Inc.	New York, N. Y.	74276	Signalite Inc.	Neptune, N. J.			Venice, Calif.
65092	Weston Inst. Inc. Weston-Newark	Newark, N. J.	74455	J. H. Winns, and Sons	Winchester, Mass.			
66295	Witte Mfg. Co.	Chicago, Ill.	74861	Industrial Condenser Corp.	Chicago, Ill.			
66346	Minnesota Mining & Mfg. Co. Revere Mincom Div.	St. Paul, Minn.	74868	R. F. Products Division of Amphenol-Borg Electronics Corp.	Danbury, Conn.			

TABLE 6-3.  
CODE LIST OF MANUFACTURERS (Cont'd)

Code No.	Manufacturer	Address	Code No.	Manufacturer	Address	Code No.	Manufacturer	Address
81312	Winchester Elec. Div. Litton Ind., Inc.	Oakville, Conn.	87473	Western Fibrous Glass Products Co.	San Francisco, Calif.	96067	Microwave Assoc., West Inc.	Sunnyvale, Calif.
81349	Military Specification		87664	Van Waters & Rogers Inc.	San Francisco, Calif.	96095	Hi-Q Div. of Aerovox Corp.	Olean, N. Y.
81483	International Rectifier Corp.	El Segundo, Calif.	87930	Tower Mfg. Corp.	Providence, R. I.	96256	Thordarson-Meissner Inc.	Mt. Carmel, Ill.
81541	Airpax Electronics, Inc.	Cambridge, Maryland	88140	Cutler-Hammer, Inc.	Lincoln, Ill.	96296	Solar Manufacturing Co.	Los Angeles, Calif.
81860	Barry Controls, Div. Barry Wright Corp.	Watertown, Mass.	88220	Gould-National Batteries, Inc.	St. Paul, Minn.	96306	Microswitch, Div. of Minn.-Honeywell	Freeport, Ill.
82042	Carter Precision Electric Co.	Skokie, Ill.	88698	General Mills, Inc.	Buffalo, N. Y.	96330	Carlton Screw Co.	Chicago, Ill.
82047	Sperli Faraday Inc., Copper Hewitt Electric Div.	Hoboken, N. J.	89231	Graybar Electric Co.	Oakland, Calif.	96341	Microwave Associates, Inc.	Burlington, Mass.
82116	Electric Regulator Corp.	Norwalk, Conn.	89473	G. E. Distributing Corp.	Schenectady, N. Y.	96501	Excel Transformer Co.	Oakland, Calif.
82142	Jeffers Electronics Division of Speer Carbon Co.	Du Bois, Pa.	89665	United Transformer Co.	Chicago, Ill.	96733	San Fernando Elect. Mfg. Co.	San Fernando, Calif.
82170	Fairchild Camera & Inst. Corp. Space & Defense System Div.	Paramus, N. J.	90030	United Shoe Machinery Corp.	Beverly, Mass.	96881	Thomson Ind. Inc.	Long Is., N. Y.
82209	Maguire Industries, Inc.	Greenwich, Conn.	90179	US Rubber Co., Consumer Ind. & Plastics Prod. Div.	Passaic, N. J.	97464	Industrial Retaining Ring Co.	Irvington, N. J.
82219	Sylvania Electric Prod. Inc. Electronic Tube Division	Emporium, Pa.	90970	Bearing Engineering Co.	San Francisco, Calif.	97539	Automatic & Precision Mfg.	Englewood, N. J.
82376	Astron Corp.	East Newark, Harrison, N. J.	91146	ITT Cannon Elect. Inc., Salem Div.	Salem, Mass.	97979	Reon Resistor Corp.	Yonkers, N. Y.
82389	Switchcraft, Inc.	Chicago, Ill.	91260	Connor Spring Mfg. Co.	San Francisco, Calif.	97983	Litton System Inc., Adler-Westrex Commun. Div.	New Rochelle, N. Y.
82647	Metals & Controls Inc. Spencer Products	Attleboro, Mass.	91345	Miller Dial & Nameplate Co.	El Monte, Calif.	98141	R-Tronics, Inc.	Jamaica, N. Y.
82768	Phillips-Advance Control Co.	Joliet, Ill.	91418	Radio Materials Co.	Chicago, Ill.	98159	Rubber Teck, Inc.	Gardena, Calif.
82866	Research Products Corp.	Madison, Wis.	91506	Augat Inc.	Attleboro, Mass.	98220	Hewlett-Packard Co., Moseley Div.	Pasadena, Calif.
82877	Rotron Mfg. Co., Inc.	Woodstock, N. Y.	91637	Dale Electronics, Inc.	Columbus, Neb.	98278	Microdot, Inc.	So. Pasadena, Calif.
82893	Vector Electronic Co.	Glendale, Calif.	91662	Elco Corp.	Willow Grove, Pa.	98291	Sealectro Corp.	Mamaroneck, N. Y.
83058	Carr Fastener Co.	Cambridge, Mass.	91737	Gremar Mfg. Co., Inc.	Wakefield, Mass.	98376	Zero Mfg. Co.	Burbank, Calif.
83086	New Hampshire Ball Bearing, Inc.	Peterborough, N. H.	91827	K F Development Co.	Redwood City, Calif.	98410	Etc Inc.	Cleveland, Ohio
83125	General Instrument Corp., Capacitor Div.	Darlington, S. C.	91886	Malco Mfg. Co., Inc.	Chicago, Ill.	98731	General Mills Inc., Electronics Div.	Minneapolis, Minn.
83148	ITT Wire and Cable Div.	Los Angeles, Calif.	91929	Honeywell Inc., Micro Switch Div.	Freeport, Ill.	98734	Paeco Div. of Hewlett-Packard Co.	Palo Alto, Calif.
83186	Victory Eng. Corp.	Springfield, N. J.	91961	Nahn-Bros. Spring Co.	Oakland, Calif.	98821	North Hills Electronics, Inc.	Glen Cove, N. Y.
83298	Bendix Corp., Red Bank Div.	Red Bank, N. J.	92180	Tru-Connector Corp.	Peabody, Mass.	98978	International Electronic Research Corp.	Burbank, Calif.
83315	Hubbell Corp.	Mundelein, Ill.	92367	Elgeet Optical Co. Inc.	Rochester, N. Y.	99109	Columbia Technical Corp.	New York, N. Y.
83324	Rosan Inc.	Newport Beach, Calif.	92607	Tensolite Insulated Wire Co., Inc.	Tarrytown, N. Y.	99313	Varian Associates	Palo Alto, Calif.
83330	Smith, Herman H., Inc.	Brooklyn, N. Y.	92702	IMC Magnetics Corp.	Wesbury Long Island, N. Y.	99378	Atlee Corp.	Winchester, Mass.
83332	Tech Labs	Palsade's Park, N. J.	92966	Hudson Lamp Co.	Kearney, N. J.	99515	Marshall Ind., Capacitor Div.	Monrovia, Calif.
83385	Central Screw Co.	Chicago, Ill.	93332	Sylvania Electric Prod. Inc. Semiconductor Div.	Woburn, Mass.	99707	Control Switch Division, Controls Co. of America	El Segundo, Calif.
83501	Gavitt Wire and Cable Co. Div. of Amerace Corp.	Brookfield, Mass.	93369	Robbins & Myers Inc.	Palisades Park, N. J.	99800	Delevan Electronics Corp.	East Aurora, N. Y.
83594	Burroughs Corp. Electronic Tube Div.	Plainfield, N. J.	93410	Stemco Controls, Div. of Essex Wire Corp.	Mansfield, Ohio	99848	Wilco Corporation	Indianapolis, Ind.
83740	Union Carbide Corp. Consumer Prod. Div.	New York, N. Y.	93632	Waters Mfg. Co.	Culver City, Calif.	99928	Branson Corp.	Whippany, N. J.
83777	Model Eng. and Mfg., Inc.	Huntington, Ind.	93929	G. V. Controls	Livingston, N. J.	99934	Renbrandt, Inc.	Boston, Mass.
83821	Loyd Scruggs Co.	Festus, Mo.	94137	General Cable Corp.	Bayonne, N. J.	99942	Hoffman Electronics Corp. Semiconductor Div.	El Monte, Calif.
83942	Aeronautical Inst. & Radio Co.	Lodi, N. J.	94144	Raytheon Co., Comp. Div., Ind. Comp. Operations	Quincy, Mass.	99957	Technology Instrument Corp. of Calif.	Newbury Park, Calif.
84171	Arco Electronics Inc.	Great Neck, N. Y.	94148	Scientific Electronics Products, Inc.	Loveland, Colo.			
84396	A. J. Glesener Co., Inc.	San Francisco, Calif.	94154	Wagner Elect. Corp., Tung-Sol Div.	Newark, N. J.			
84411	TRW Capacitor Div.	Ogallala, Neb.	94197	Curtiss-Wright Corp. Electronics Div.	East Paterson, N. J.			
84970	Sarkes Tarzian, Inc.	Bloomington, Ind.	94222	South Chester Corp.	Chester, Pa.			
85454	Boonton Molding Company	Boonton, N. J.	94330	Wire Cloth Products, Inc.	Bellwood, Ill.			
85471	A. B. Boyd Co.	San Francisco, Calif.	94375	Automatic Metal Products Co.	Brooklyn, N. Y.			
85474	R. M. Bracamonte & Co.	San Francisco, Calif.	94682	Worcester Pressed Aluminum Corp.	Worcester, Mass.			
85660	Korled Korids, Inc.	Hamden, Conn.	94696	Magnecraft Electric Co.	Chicago, Ill.			
85911	Seamless Rubber Co.	Chicago, Ill.	95023	George A. Philbrick Researchers, Inc.	Boston, Mass.			
86174	Fafnir Bearing Co.	Los Angeles, Calif.	95236	Allies Products Corp.	Dania, Fla.	000UF	Malco Tool and Die	Los Angeles, Calif.
86197	Clifton Precision Products Co., Inc.	Clifton Heights, Pa.	95238	Continental Connector Corp.	Woodside, N. Y.	000UZ	Willow Leather Products Corp.	Newark, N. J.
86579	Precision Rubber Products Corp.	Dayton, Ohio	95263	Leocraft Mfg. Co., Inc.	Long Island, N. Y.	000AB	ETA	England
86684	Radio Corp. of America, Electronic Comp. & Devices Div.	Harrison, N. J.	95265	National Coil Co.	Sheridan, Wyo.	000BB	Precision Instrument Components Co.	Van Nuys, Calif.
86928	Seastrom Mfg. Co.	Glendale, Calif.	95275	Vitramon, Inc.	Bridgeport, Conn.	000CS	Hewlett-Packard Co., Colorado Springs	Colorado Springs, Colorado
87034	Marco Industries	Anaheim, Calif.	95348	Gordos Corp.	Bloomfield, N. J.	000MM	Rubber Eng. & Development	Hayward, Calif.
87216	Philco Corporation (Lansdale Division)	Lansdale, Pa.	95354	Method Mfg. Co.	Rolling Meadows, Ill.	000NN	A "N" D Mfg. Co.	San Jose, Calif.
			95566	Arnold Engineering Co.	Marengo, Ill.	000QQ	Cooltron	Oakland, Calif.
			95712	Dage Electric Co., Inc.	Franklin, Ind.	000WW	California Eastern Lab.	Burlington, Calif.
			95984	Siemon Mfg. Co.	Wayne, Ill.	000YY	S. K. Smith Co.	Los Angeles, Calif.
			95987	Weckesser Co.	Chicago, Ill.			

THE FOLLOWING HP VENDORS HAVE NO NUMBER ASSIGNED IN THE LATEST SUPPLEMENT TO THE FEDERAL SUPPLY CODE FOR MANUFACTURERS HANDBOOK.

000UF	Malco Tool and Die	Los Angeles, Calif.
000UZ	Willow Leather Products Corp.	Newark, N. J.
000AB	ETA	England
000BB	Precision Instrument Components Co.	Van Nuys, Calif.
000CS	Hewlett-Packard Co., Colorado Springs	Colorado Springs, Colorado
000MM	Rubber Eng. & Development	Hayward, Calif.
000NN	A "N" D Mfg. Co.	San Jose, Calif.
000QQ	Cooltron	Oakland, Calif.
000WW	California Eastern Lab.	Burlington, Calif.
000YY	S. K. Smith Co.	Los Angeles, Calif.

From: FSC. Handbook Supplements  
H4-1 Dated AUGUST 1966

00015-46  
Revised: August, 1968

02334-2

3-11



# **SCHEMATIC DIAGRAMS**

## SECTION IV SCHEMATIC DIAGRAMS

### 4-1. INTRODUCTION.

4-2. Schematic presentations in this manual show electrical circuit operation and are not intended to serve as wiring diagrams. Figure 4-1 lists notes which apply to the schematic diagrams.

4-3. Some switch and circuit board assemblies are shown in part on different pages. To find a specific instrument component, refer to the "REFERENCE DESIGNATIONS" box which appears on each schematic diagram. Reference designations within assemblies are abbreviated. The full designation includes the assembly on which the component is mounted, and the

individual component designation. For example, Resistor R1 mounted on Assembly A1 has the complete reference designation of A1R1. Certain parts are not included on assemblies, and are classified as chassis parts. Chassis parts are assigned only the reference designation shown on the schematic diagram.

4-4. An asterisk indicates a factory selected part; the component value shown is the typical or most commonly selected value.

4-5. Component procurement information and specific component descriptions are included in Section III. Refer to page 3-1 for information on how to order parts.

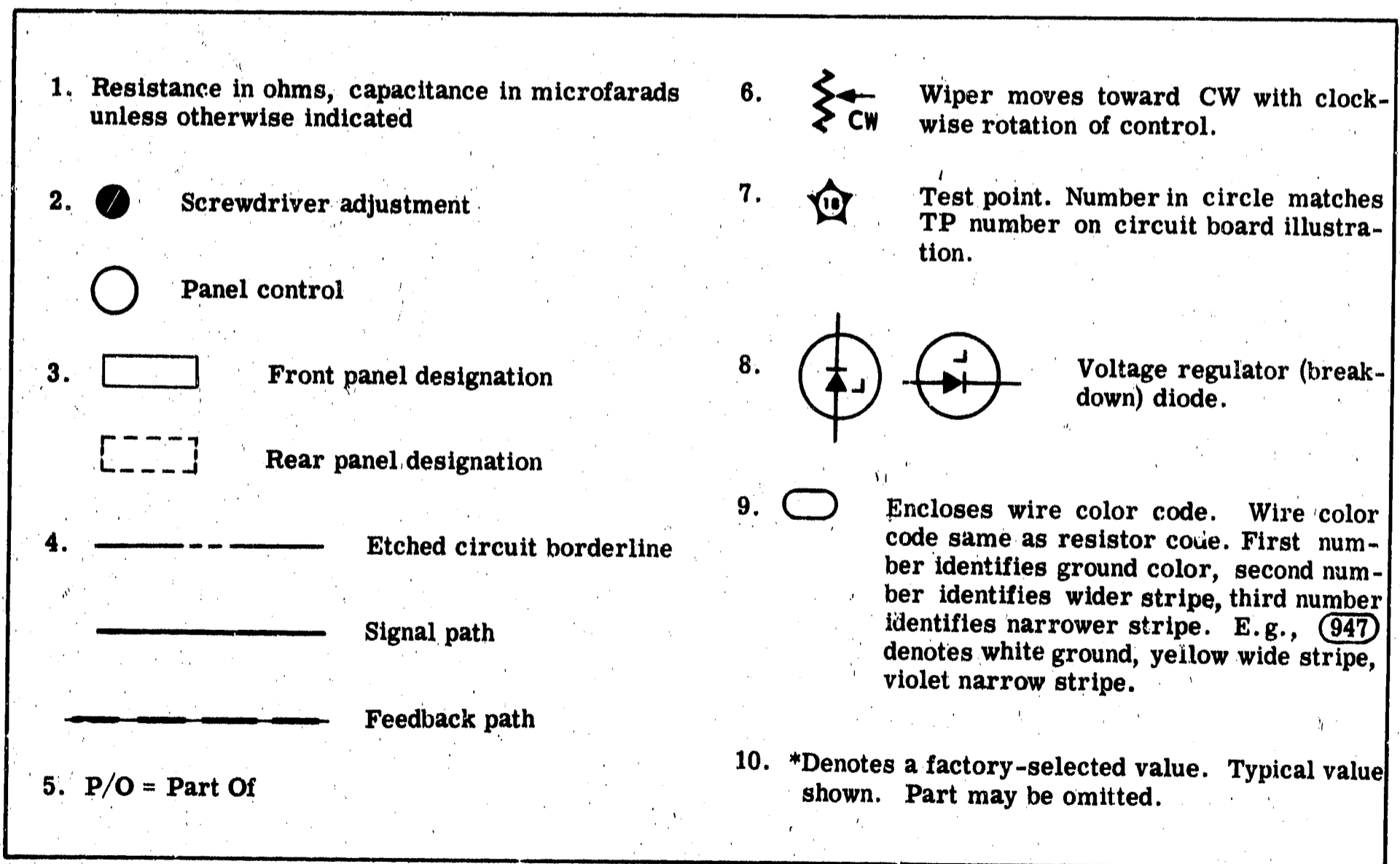

Figure 4-1. Schematic Diagram Notes

- NOTES**
1. RESISTORS A1R36 AND A1R37 SELECTED FOR 40V P-P PER OCTAVE AT J1.
  2. VALUE OF A1R17 DEPENDENT ON BWO MANUFACTURE.
  3. LETTERED CONNECTIONS ARE ON P11. P11 CONNECTS TO 8690B J11. NUMBERED CONNECTIONS ARE ON P12. P12 CONNECTS TO 8690B J12.
  4. FACTORY SELECTED PART.

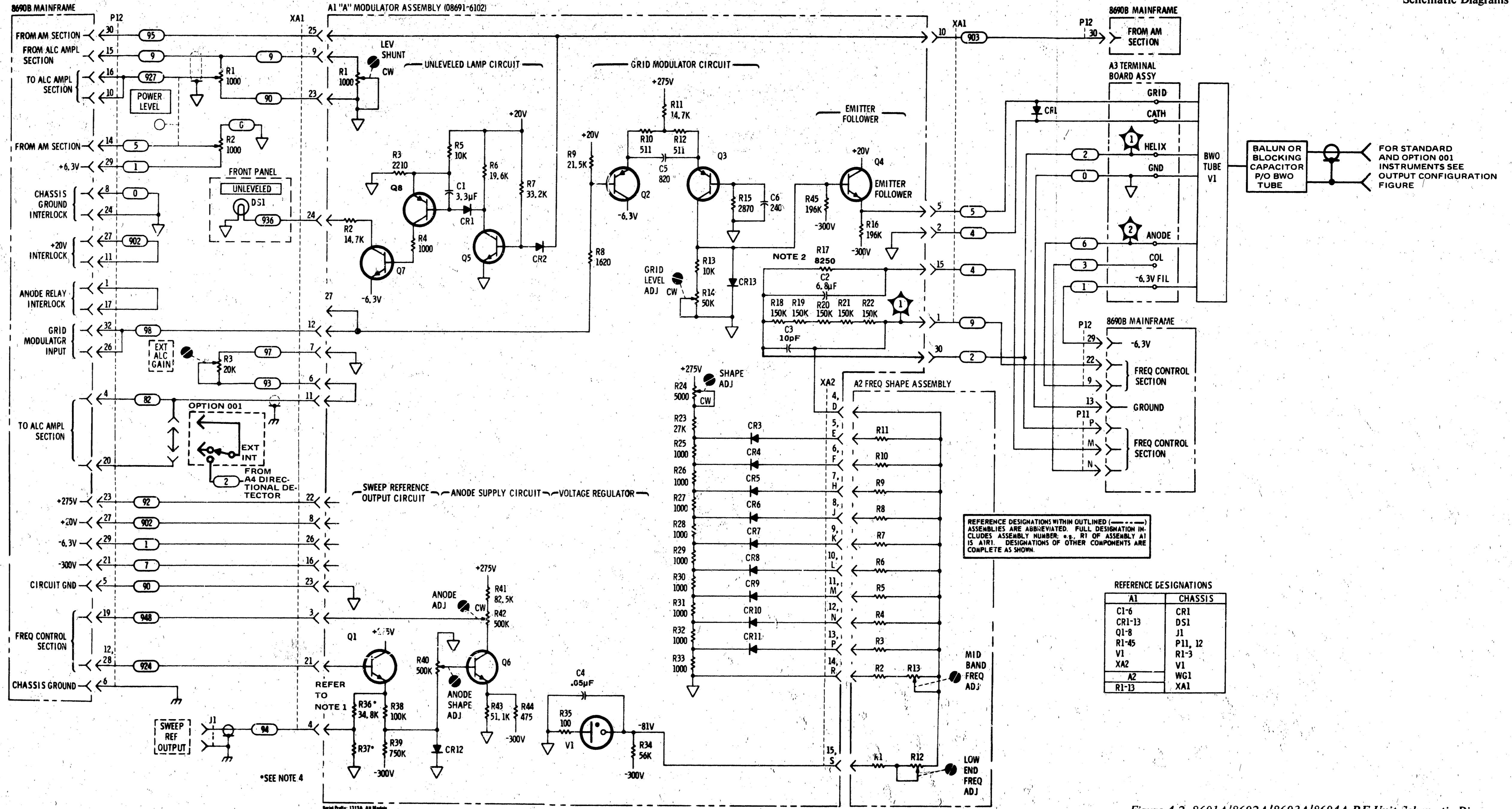
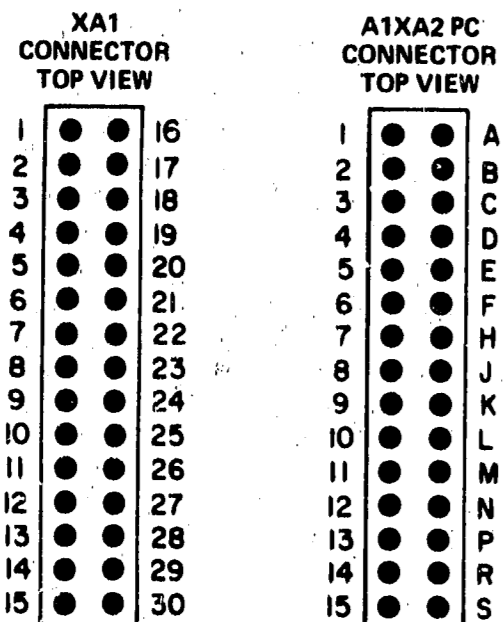
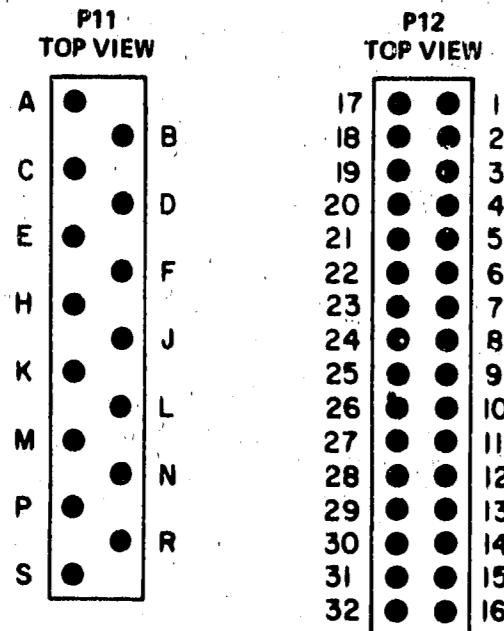

Figure 4-2. 8691A/8692A/8693A/8694A RF Unit Schematic Diagram

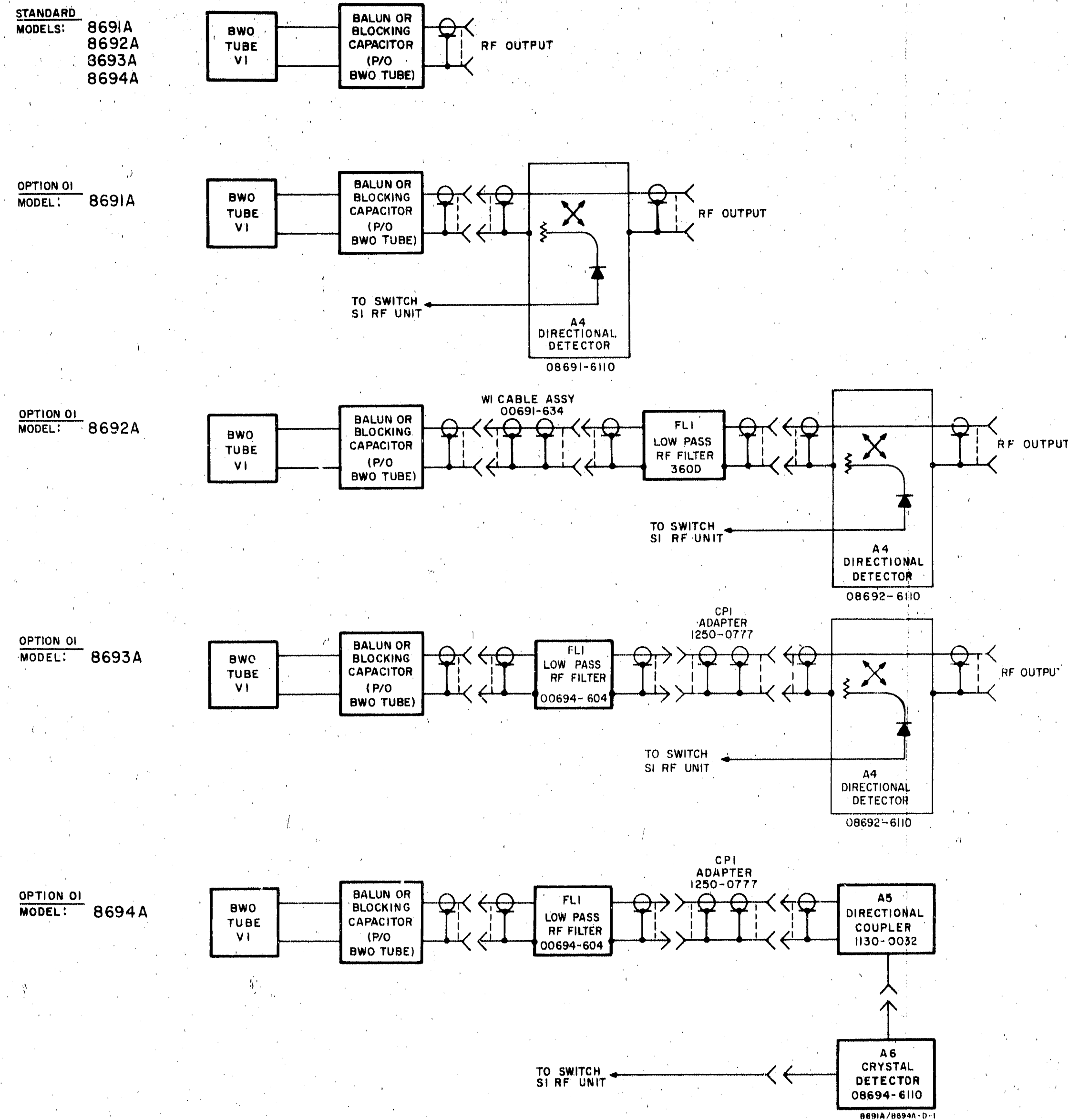
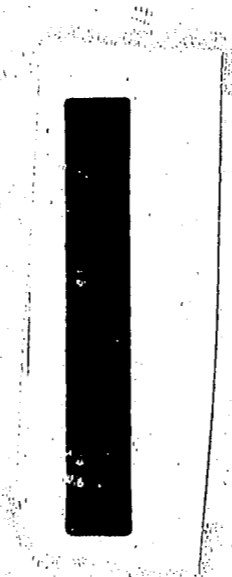

Figure 4-3. Output Configurations

# APPENDIX



APPENDIX I

# DIRECTIONAL DETECTORS

models  
786D  
787D  
788C

OPERATING NOTE 3 AUG 66

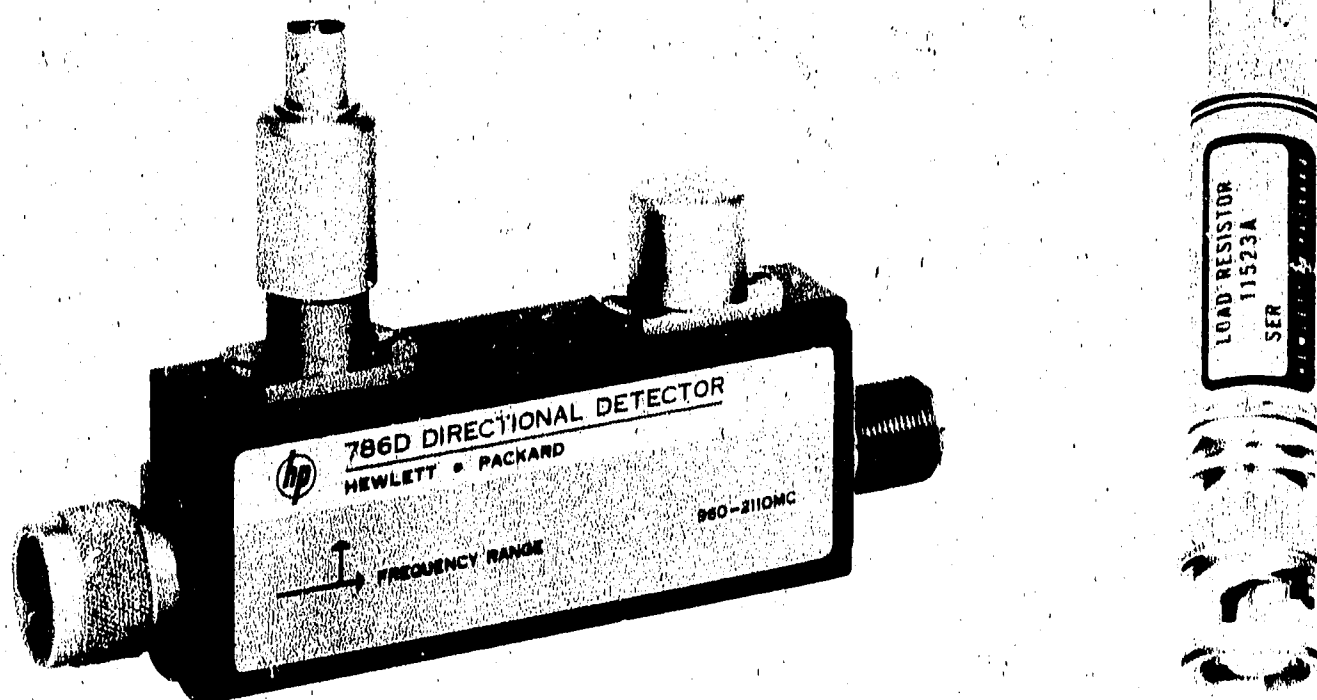

Figure 1. Model 786D and Option 02 Accessory Load Resistor

Table 1. Specifications

Model	Frequency Range (Gc)	Sensitivity <sup>1</sup>		Minimum Directivity <sub>v</sub>	Equivalent Source Reflection Coefficient <sup>6</sup>	Frequency Response <sup>3</sup>	Max Main Line SWR	Max Main Line Input	Insertion Loss <sup>4</sup>
		Low Level	High Level <sup>2</sup>						
786D	0.96 - 2.11	> 4 $\mu\text{v}/\mu\text{w}$ CW	35 mw	30 db	$\leq 0.06$ (1.13 swr)	$\pm 0.2$ db	1.15	10 w	$\approx 0.25$ db
787D	1.9 - 4.1	> 4 $\mu\text{v}/\mu\text{w}$ CW	35 mw	26 db	$\leq 0.075$ (1.16 swr)	$\pm 0.2$ db	1.15	10 w	$\approx 0.35$ db
788C	3.7 - 8.3	> 40 $\mu\text{v}/\mu\text{w}$ CW	3.5 mw	20 db	$\leq 0.111$ (1.25 swr)	$\pm 0.3$ db	1.20	1 w	$\approx 0.6$ db

<p>Noise: Less than 200 <math>\mu\text{v}</math> peak-to-peak with CW power applied to produce 100 mv output</p> <p>Detector Output Polarity: Negative</p> <p>Detector Output Connector: BNC female</p> <p>Detector Output Impedance: 15K max shunted by about 10 pf</p> <p>Detector Element: Supplied</p> <p>RF Connectors<sup>5</sup>: <math>\phi</math> precision type N, one male (input), one female</p> <p>Size: Refer to Figure 2</p>	<p>Net Weight:</p> <p>786D - 16 oz (450 g)</p> <p>787D - 12 oz (340 g)</p> <p>788C - 12 oz (340 g)</p> <p>Options:</p> <p>02. Furnished <math>\phi</math> 11523A load resistor for optimum square-law characteristics at 24°C (75°F), <math>\leq \pm 0.5</math> db variation from square-law for outputs up to 50 mv peak (working into an external load <math>&gt; 75\text{K}</math>). Sensitivity when load is used is typically <math>&gt; 1 \mu\text{v}/\mu\text{w}</math> CW for 786D and 787D, and <math>&gt; 10 \mu\text{v}/\mu\text{w}</math> CW for 788C.</p> <p>03. Positive polarity detector output.</p>
--	--

<p><sup>1</sup> With respect to power output</p> <p><sup>2</sup> Power required to produce at least a 100-mv output</p> <p><sup>3</sup> As read on a meter calibrated for square law</p> <p><sup>4</sup> Including loss due to coupling</p>	<p><sup>5</sup> CAUTION: <math>\phi</math> precision type N connectors do not mate with each other. They mate only with standard type N connectors.</p> <p><sup>6</sup> The apparent reflection coefficient at the output of an RF generating system, such as the output of a directional detector when it is used in a closed-loop leveling system.</p>
---	--

01986-4

00786-90005

Printed in U.S.A.

## 1. INTRODUCTION.

2. The Directional Detector, a directional coupler with built-in crystal detector, is designed for use in coaxial systems over a relatively wide frequency range. Applications include closed-loop leveling, observation of RF envelope variation, and power monitoring. Output polarity of detected signal is normally negative, but positive output polarity is available as Option 03. Figure 1 shows Model 786D with Option 02 Load Resistor, available when optimum conformance to square-law characteristics is required. Table 1 lists complete instrument specifications.

3. The directional detector and the optional square-law load (Ⓢ 11523A) are separately housed. This arrangement permits choice of directional detector operation for optimum square-law response for detected outputs of up to 50 mv (with the load attached) or maximum output sensitivity (without the load). For proper identification the directional detector carries the same serial number as the load. Always check that the serial number of the load and directional detector are identical.

## 4. PRECAUTIONS.

### 5. STATIC ELECTRICAL DAMAGE.

6. The maximum pulse rating for the detector element (diode) used in the directional detector is 0.1 erg of energy. A four-foot length of coaxial RG58/U cable, the equivalent of a 100-pf capacitor, when charged to 14 volts, is the equivalent of 0.1 erg of energy. Be certain that connecting cables are always connected to associated equipment and discharged before connecting to the detector output.

### 7. HANDLING DAMAGE.

8. **DO NOT HANDLE DETECTOR ELEMENT NEEDLESSLY.** Static electricity which builds up on the body, especially on cold, dry days, must never be allowed to discharge through the detector element. Avoid exposed leads to or from the detector output, since these are often touched accidentally. Refer to Paragraph 23 for proper precautions.

## 9. OPERATION.

10. The directional detector is useful as the sampling and detection device in closed-loop leveling setups as described in Paragraph 16. It can also be used as a calibrated power monitor by determining the correlation between detected output and main-line RF output levels, or for relative RF envelope observation with an oscilloscope. If the directional detector is to be permanently mounted for any application, refer to Figure 2, which illustrates the location of the four mounting holes and the general side dimensions. Before installing in any setup, the following should be considered:

a. The type N connectors are Ⓢ precision type N connectors which are designed to mate with standard 50-ohm type N connectors. When mating with any other device equipped with Ⓢ precision type N connectors, connector damage will result unless an adapter is used. Precision connector dimensions are given in Figure 3.

b. The detector element used is sensitive to either amplitude-modulated or continuous-wave (CW) RF power. If RF power is amplitude modulated at a 1000-cps  $\pm 2\%$  rate, the sensitive Ⓢ Model 415B or 415D (SWR Meter) can be used as the indicator. For CW detection, a DC milliammeter or millivoltmeter (with an input impedance of at least 100K ohms), such as the Ⓢ Model 425A Microvolt-Ammeter can be used as the indicator.

c. When using an oscilloscope to observe waveshapes of rise times less than 5  $\mu$ sec, the coaxial cable connecting the detected output and the oscilloscope should be as short as possible and terminated with a shunting resistor. Ideally, this resistor should be 50 ohms to terminate the coaxial cable in its characteristic impedance. However, with 50 ohms, the video pulse may have too small an amplitude to drive some oscilloscopes. Typically, the required value is between 50 and 2000 ohms. The larger the resistance, the slower the observable rise time. Oscilloscopes ideal for this application are the Ⓢ Models 140A or 175A, depending upon required bandwidth.

d. A low-pass filter should be used in all applications of the directional detector where harmonic frequencies may be present.

## 11. SENSITIVITY CHARACTERISTICS.

12. The sensitivity characteristics of the Directional Detectors is well defined in two ranges of main line RF power output, a lower range extending up to 500  $\mu$ w (50  $\mu$ w for the 788C) and a higher range between 5 and 35 mw (0.5 and 3.5 mw for the 788C). In the lower range the ratio of detected output to main line RF power output (sensitivity), in microvolts per microwatt, is at least 4:1 (40:1 for the 788C). In the higher range the ratio, in millivolts per milliwatt, is at least 2.85:1 (28.5:1 for the 788C). Between ranges, and beyond the higher range, sensitivity characteristics vary from detector element to detector element. Beyond the higher range sensitivity diminishes to a saturation level (a maximum detected output of 300 to 500 mv) where increased main line RF power produces no significant increase in detected output.

## 13. SQUARE-LAW LOADING.

14. The square-law load (Ⓢ 11523A) is selected for optimum response (minimum deviation from square law) at 24°C (75°F). Typically, detected output varies  $\pm 0.3$  db from exact square law for values of output voltage between 5 mv and 50 mv. At higher temperatures output voltage vs input power deviation is more negative and at lower temperatures the opposite is true. The change with temperature is approximately 0.04 db/°C. For example, a detected output which varies  $\pm 0.3$  db from exact square law at 24°C would vary about -0.2 to +0.4 db at 22°C (72°F).

## 15. CLOSED-LOOP LEVELING.

16. **TECHNIQUE.** The Directional Detector has a direct application in systems employing closed-loop leveling of an RF source. Any variation in the RF output level causes a proportional variation in the detected output level, and this is fed back to maintain a virtually constant RF output level. Generally, an

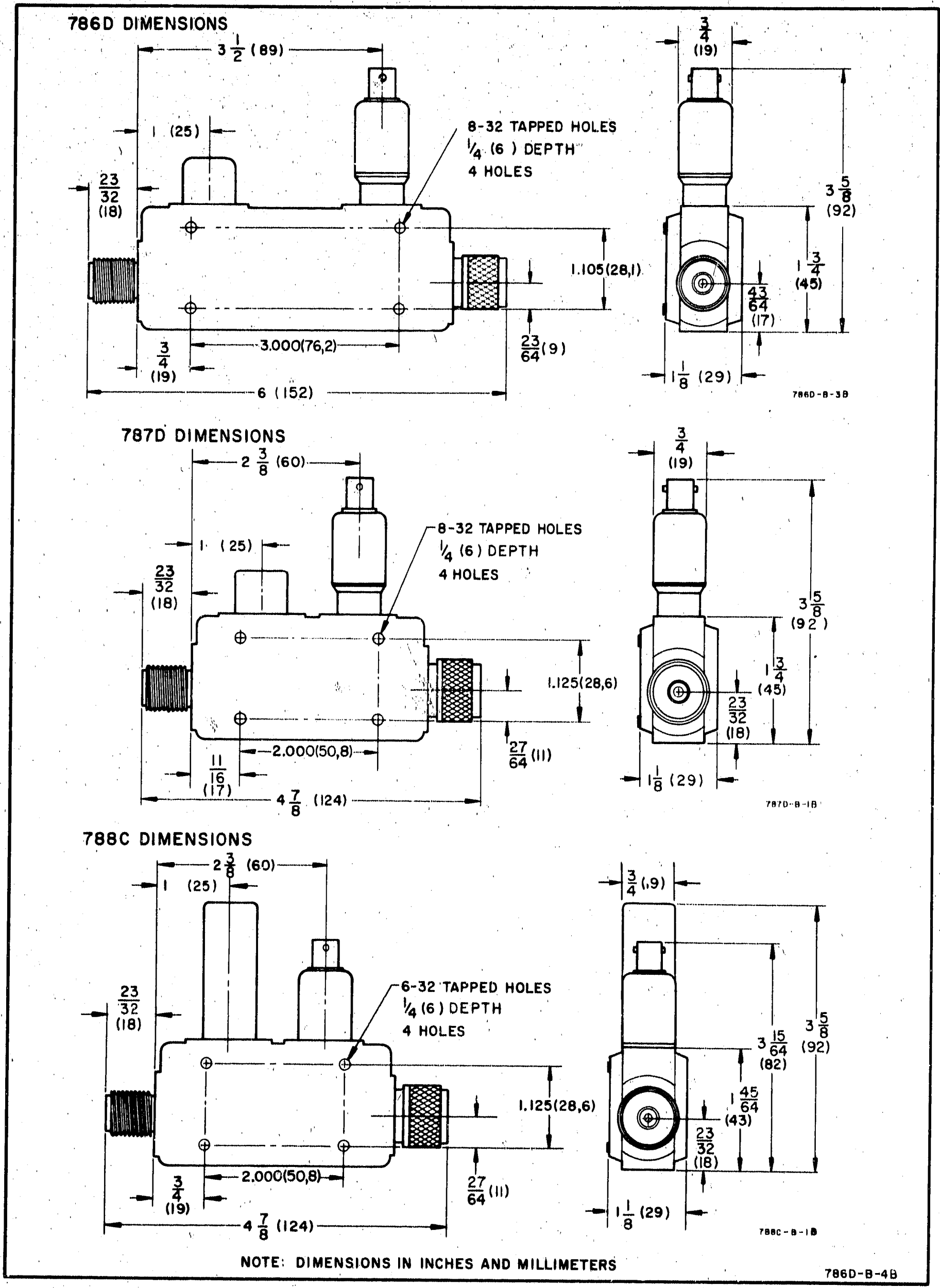

Figure 2. Outside Dimensions



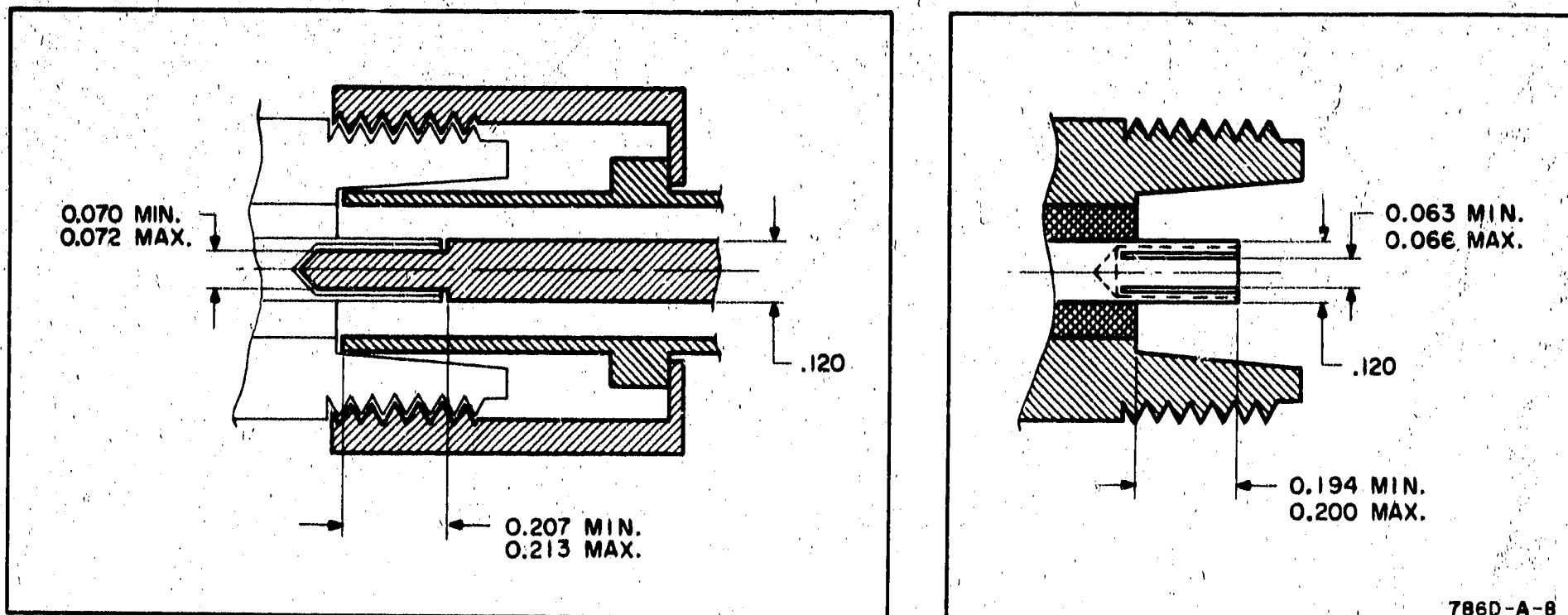

Figure 3. Precision Type N Connector Dimensions

amplifier, such as the  $\text{hp}$  Model H01-8401A is required between the detector and the RF source, although some sources such as the  $\text{hp}$  690 series Sweep Oscillators have built-in leveling amplifiers.

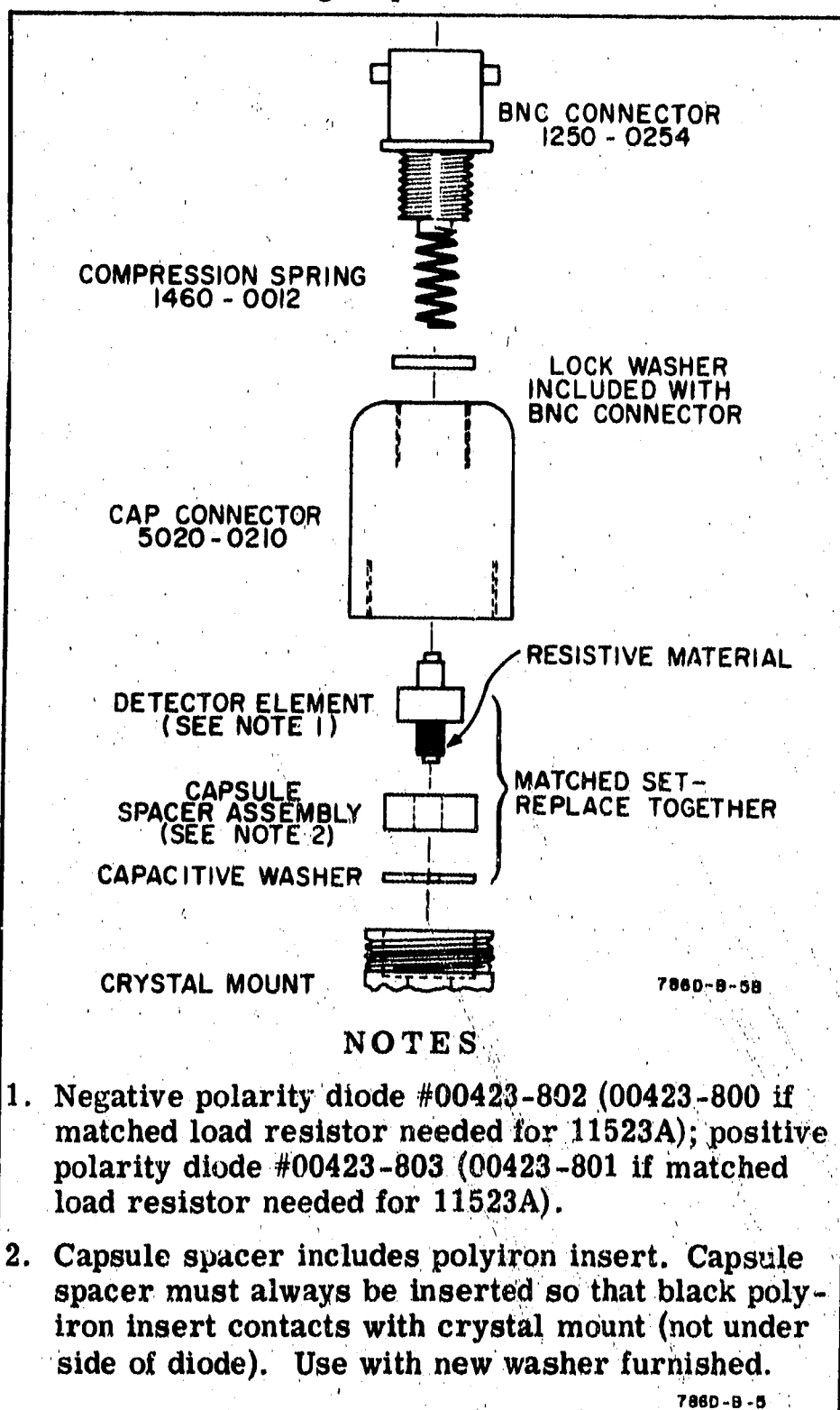

Figure 4. Detector Unit Assembly

17. **LEVELING CAPABILITY.** The leveling capability of the leveler-amplifier/directional-detector combination is limited mainly by the frequency response of the detector and the response of the leveler amplifier. When the 786D is used to level the  $\text{hp}$  Model 691A Sweep Oscillator, RF variations into a matched load are less than  $\pm 0.3$  db.

#### 18. CALIBRATED POWER MONITOR.

19. The Directional Detector can also be used as a power monitor. By determining the correlation between the detected output and the main-line RF output levels the detected output can be calibrated directly in mv/mw and the directional detector can then be used to sample and indicate RF power levels at any point in a system. A power meter can be used to measure main-line RF output levels for calibration of the detected output. An Oscilloscope, DC Voltmeter, or SWR Meter can be used to measure the detected output.

#### 20. MAINTENANCE.

21. Succeeding paragraphs give instructions for repair of the directional detector and the 11523A (Option 02) Load Resistor. Figure 4 illustrates the replaceable detector assembly for the 786D, 787D, and 788C. Figure 5 illustrates the replaceable load assembly for the 788C, 786D and 787D load assemblies are not field-replaceable. Figure 6 and 7 illustrate the replaceable 11523A load resistor assembly. Stock numbers required when ordering replacement parts are given in the respective assembly illustrations. To order a replacement part, address order of inquiry to your local Hewlett-Packard sales and service office (see listings at the rear of this Note).

#### 22. DETECTOR ELEMENT REPLACEMENT.

##### CAUTION

The detector element (see Figure 4) can be damaged electrically by incorrect handling. Read the following handling precautions before doing anything which involves detector element.

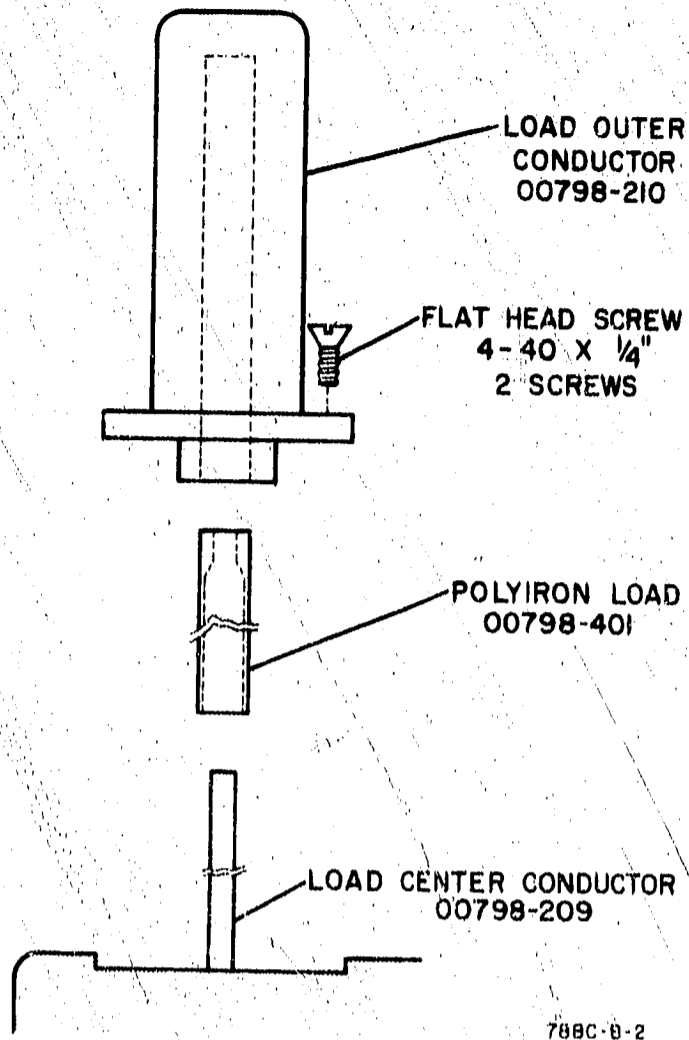

Figure 5. 788C Load Assembly

**23. HANDLING PRECAUTIONS.**

- a. Before installing detector element in mount, touch exposed metal on mount with hand to discharge any static charge. Then insert detector element.
- b. When handing crystal to another person, touch hands first to ensure there is no difference in static electrical potential between you.
- c. Do not use an ohmmeter to measure forward- and back-resistance. The open-circuit voltages and short-circuit currents from the ohmmeter can damage detector element (diode).

**24. PROCEDURE.**

- a. Note Figure 4 and remove connector cap from body. To remove connector cap, use gas pliers with nylon teeth or protect connector body with heavy paper or tape.
- b. Remove old detector element.
- c. Install replacement detector element; black resistive end goes into crystal mount (detector element is a snug fit but not a forced fit).
- d. Replace connector cap and **TIGHTEN FIRMLY.**

**Note**

A resistor is included with each replacement detector element ordered by the -800 or -801 number given in Figure 4. The resistor is for use in 11523A Load Resistor and must be installed to retain proper square-law operation if the directional detector is equipped with this optional load.

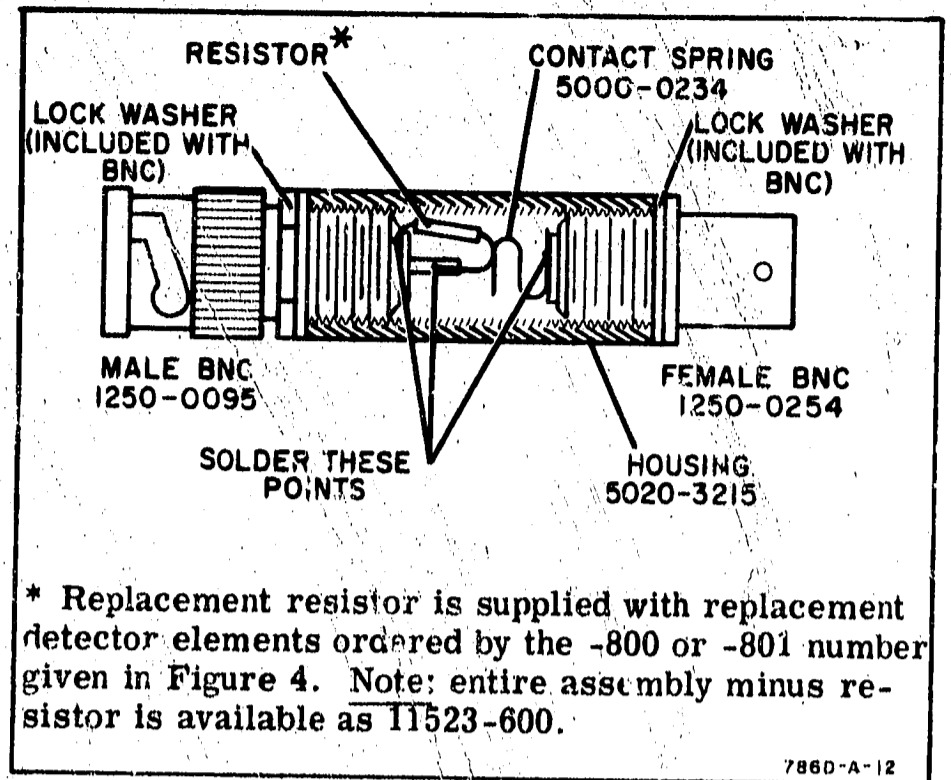

Figure 6. 11523A Cutaway View

**25. DETECTOR BNC REPLACEMENT.**

**26. TOOLS REQUIRED.**

- a. Needle-point soldering iron.
- b. Gas pliers with nylon teeth.
- c. Male BNC mating connector.
- d. Tweezers.

**27. PROCEDURE.**

- a. Refer to Figure 4. Remove BNC connector and lockwasher.
- b. Unsolder spring soldered to center conductor lead.
- c. Slip spring over center conductor lead of new BNC and solder.
- d. Let spring cool and then replace lockwasher and connector in connector cap.

**28. 788C LOAD REPLACEMENT.**

- a. Refer to Figure 5. Remove two retaining screws and the load outer conductor.
- b. Remove load and any loose or broken portions of the old load from inside the load outer conductor.
- c. Replacement is the reverse of removal.

**29. REPLACEMENT OF 11523A MALE BNC.**

- a. Refer to Figure 6. Unscrew male BNC and lockwasher from housing by using a 3/8-inch open-end wrench and holding housing either in a vise or with gas pliers.

**Note**

If gas pliers do not have nylon teeth, the housing should be protected.

- b. Unsolder resistor.
- c. Solder resistor to new BNC.

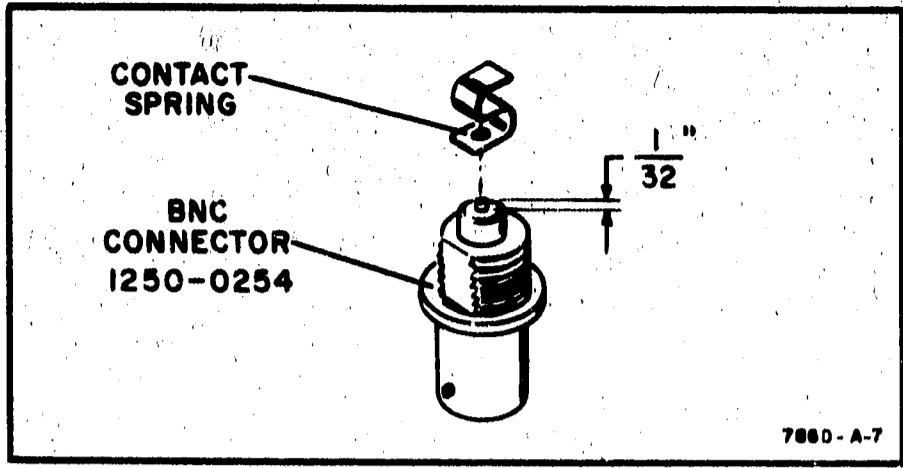

Figure 7. 11523A BNC Assembly

d. Let resistor cool, then check resistance from male BNC pin through resistor; resistance measured should be within 10% of that indicated by the coding.

e. Replace lockwasher and male BNC.

### 30. REPLACING 11523A FEMALE BNC.

a. Unscrew BNC with a BNC wrench or male BNC used as a wrench.

b. Unsolder contact spring.

c. Prepare replacement BNC connector:

(1) Cut center conductor lead to approximately 1/32 inch (refer to Figure 7).

(2) With flat file, smooth end of lead; wipe off burr with tweezers or similar metal instrument.

d. Slip contact spring over center conductor lead and solder.

#### CAUTION

Use solder sparingly or it will creep back on spring. Solder on spring destroys its usefulness and is difficult to remove.

e. Let contact spring cool and then screw BNC into housing.

### 31. PERFORMANCE CHECKS.

32. The performance check procedures given in Paragraphs 33 through 36 verify that the Directional Detector meets its specifications. Test equipment recommended for checking specifications is listed in Table 2. The critical specifications listed are the specific limitations an instrument type must meet and are not meant to be complete instrument specifications. Similar equipment having equal or better specifications than those listed may be substituted for the equipment listed. Test setups and instructions are given only for the 786D. Measurement techniques for the 787D and 788C are similar and differences in specification are mentioned where they exist.

### 33. FREQUENCY RESPONSE CHECK.

FREQUENCY RESPONSE:  $\pm 0.2$  db  
( $\pm 0.3$  db - 788C)

a. Set up test equipment as shown in Figure 8.

b. Set Sweep Oscillator for a leveled RF output.

c. Set RF output level for a convenient reference near full scale on Power Meter.

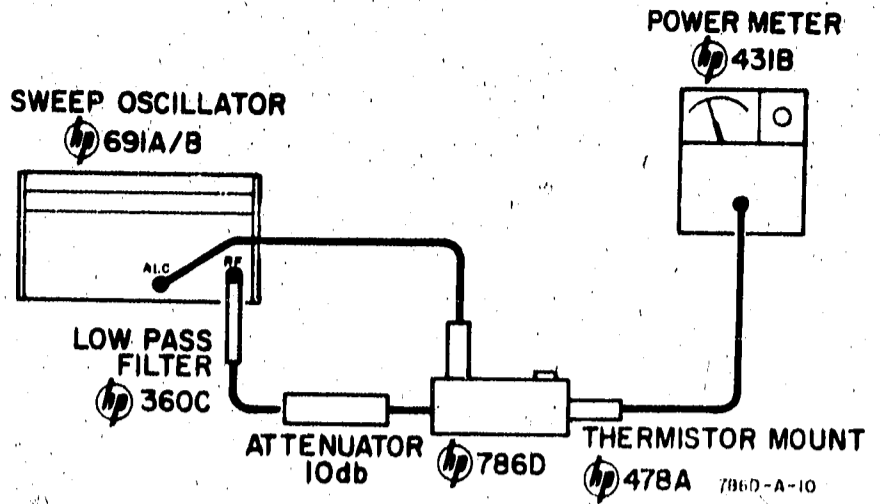

Figure 8. Frequency Response Check

d. Set Sweep Oscillator for 100-second sweep and note Power Meter indication. Specification: variation should not be greater than 0.4 db (0.6 db - 788C).

e. If variation exceeds 0.4 db (0.6 db - 788C), then a single frequency check must be made across the band. A method of checking at single frequencies across the band is to tune from point to point and compare main line RF output against auxiliary line output.

### 34. SENSITIVITY CHECK.

SENSITIVITY: 100 mv detected output for 35 mw (3.5 mw - 788C) RF output.

a. Set up test equipment as shown in Figure 8 with the following exceptions: the 10-db Pad should be connected between 786D and 478A and detected output connected to a DC Voltmeter through a BNC-to-binding post adapter.

#### CAUTION

An RF power level exceeding 10 mw will damage Thermistor Mount. Be careful not to exceed 10 mw to mount.

b. Starting at minimum, carefully increase CW-RF power to obtain a 100-mv reading on the DC Voltmeter. Specification: 35 mw (3.5 mw - 788C) or less (Power Meter reading plus attenuation of Attenuator) produces a 100-mv detected output.

c. Repeat above check at all points of interest across the band.

### 35. SWR CHECK.

MAIN LINE SWR:  $\leq 1.15$  (1.20 - 788C)

a. Set up test equipment as shown in Figure 9.

b. Set Sweep Oscillator for a single frequency, 1000-cps square-wave modulated RF output.

c. Adjust square-wave modulation frequency for optimum SWR Meter indication on 40-db NORMAL scale.

d. Phase Sliding Load to obtain minimum SWR scale indication.

e. Adjust Slotted Line carriage for minimum SWR-scale indication as near center of slotted section as possible. Repeat step d, if necessary.

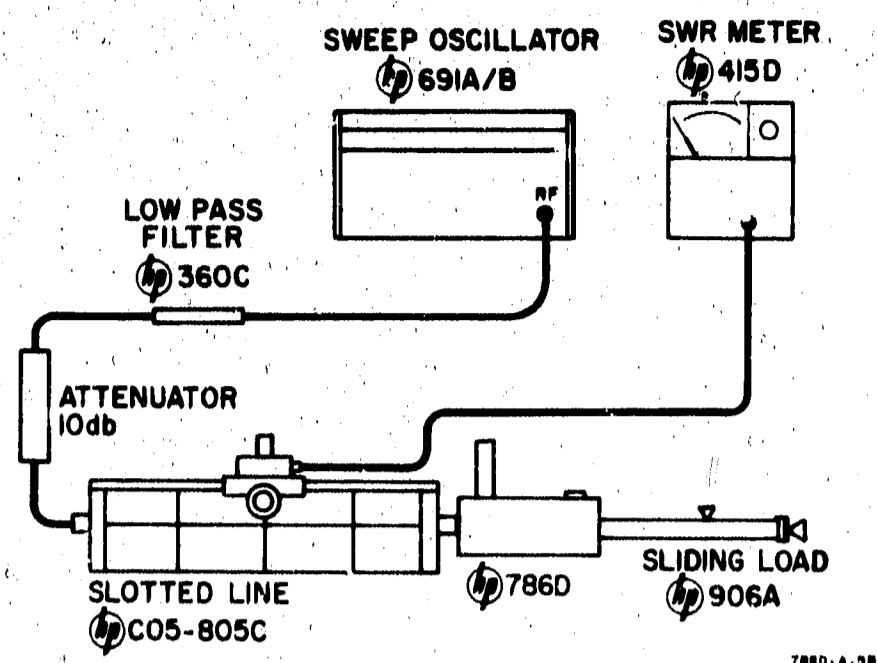

Figure 9. SWR Check

f. Set a 1.0 indication on SWR Meter SWR-EXPAND scale.

g. Adjust Slotted Line for a maximum SWR-scale indication.

h. Phase Sliding Load for a minimum reading and record. Specification: SWR reading must be equal to or less than 1.15 (1.20 - 788C).

### 36. DIRECTIVITY CHECK.

MINIMUM DIRECTIVITY: 30 db  
(26 db - 787D; 20 db - 788C)

- Set up equipment as shown in Figure 10.
- Set Sweep Oscillator for leveled, square-wave modulated RF output.
- Set 0-db reference on SWR Meter.
- Remove Attenuator from setup.
- Connect Sliding Load to male connector (786D under test) and using a female-to-female adapter connect 786D under test to 786D.
- Set Sweep Oscillator for 100-second sweep rate.
- Note SWR Meter indication and continuously phase Sliding Load. If both minimum and maximum indications are greater than the 0-db reference, the directional detector meets the directivity specification.

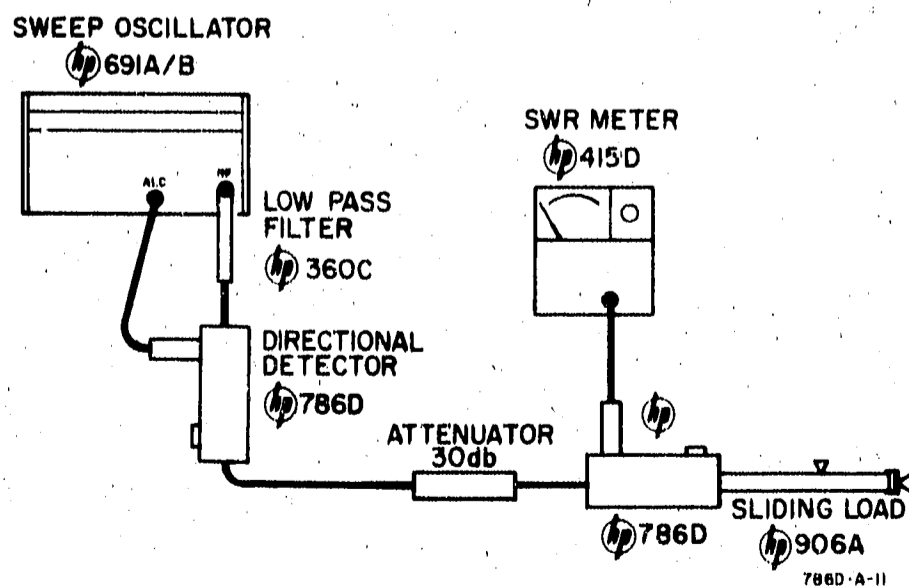

Figure 10. Directivity Check

However, these readings are uncorrected, smaller-than-actual-value readings.

h. To determine actual directivity first add attenuation of Attenuators used in step a to each reading made in step g; then subtract maximum from minimum readings and find difference value ( $M_1$ ). For example, if readings were 0.5 and 5.4 db and assuming attenuation of Attenuators used is equal to 30 db, then the minimum is 30.5 db and the maximum is 35.4 db. The difference between the two readings is 4.9 db (which is  $M_1$ ).

i. Refer to Figure 11. Determine values for  $M_2$  which are the two correction factors to be used. Add the minimum reading of step g to each correction ( $M_2$ ). For example, if the difference in db ( $M_1$ ) is 4.9 db, then from the graph (Figure 11) the two corrections are 2.1 and 13.3 db. One corrected value is Sliding Load return loss and the other is 786D directivity.

j. To identify directivity reading, loosen Sliding Load center conductor lock and slightly loosen connection to 786D without rotating center conduction. Tighten lock.

k. Repeat steps d through i. The corrected value for Sliding Load return loss should remain practically the same as original corrected reading (within a few tenths of a db). The 786D directivity is the other original corrected reading.

m. The following is an example of measurement steps with actual readings and conclusions.

- SWR Meter readings were 0.5 and 5.4 db.
- The attenuators used were 20 db and 10 db; hence, the readings indicate 30.5 and 35.4 db.
- The difference between the minimum and maximum readings is then 4.9 db.
- Referring to Figure 11, the two correction factors are 2.1 and 13.3 db.
- The minimum reading (30.5 db) added to each results in two corrected readings: 32.6 and 43.8 db.
- To determine which reading represents the Sliding Load, the center conductor is partially unplugged from the 786D.
- The above steps were repeated which resulted in SWR Meter indications of 25.5 and 28.0 db. The difference between the two readings is 2.5 db which from Figure 11 determined the two correction factors to be 1.2 and 18.0 db.
- The two correction factors added to the 25.5 db minimum gave corrected readings of 26.7 and 43.5 db.
- The Sliding Load return loss was 43.5 to 43.8 db, because making a bad connection between the Sliding Load and the 786D did not affect this reading much.
- The 786D directivity was 32.6 db, because making a bad connection between the Sliding Load and the 786D did affect this reading causing an erroneous reading which did not agree with either of the previous corrected readings.

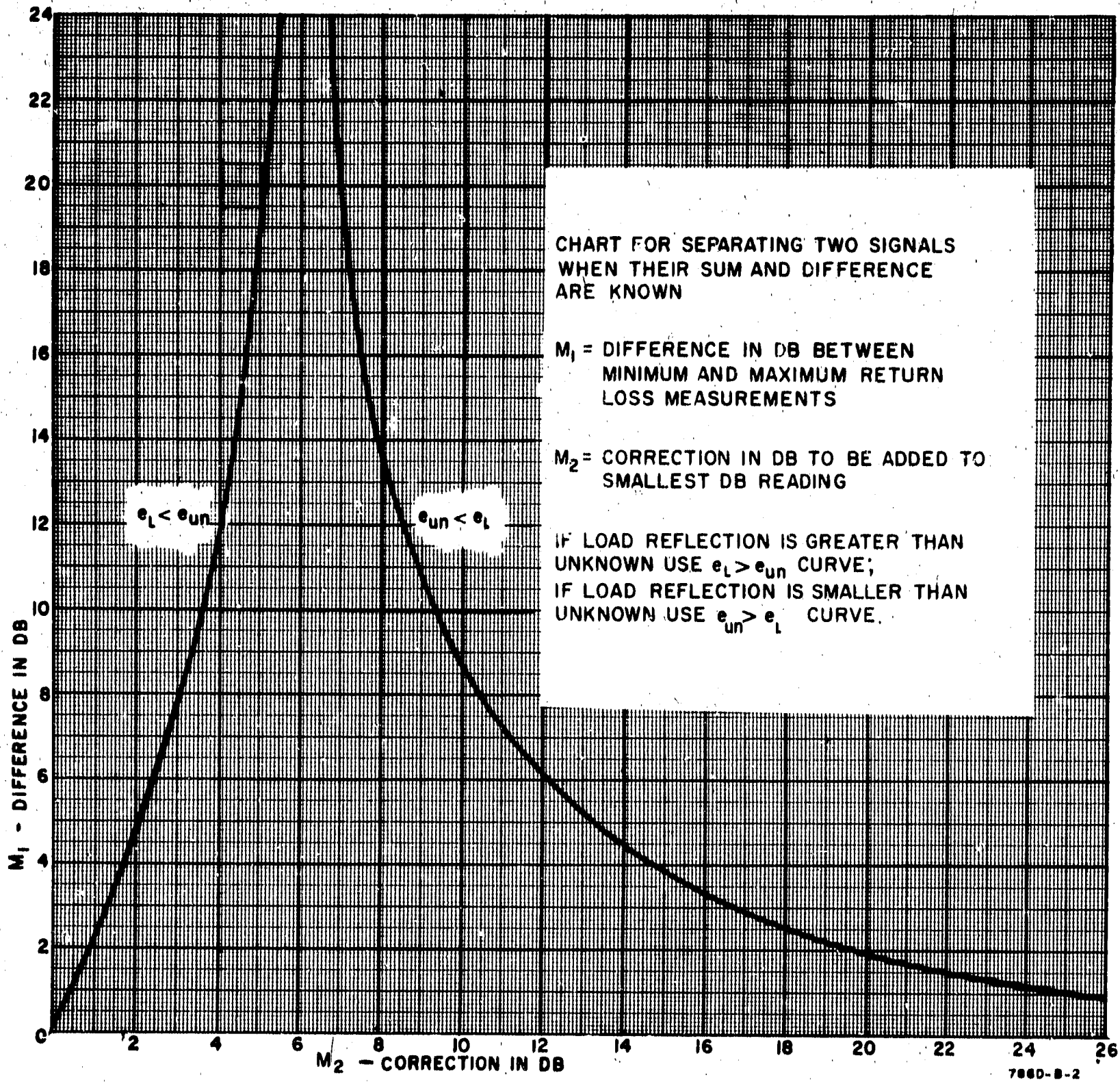

Figure 11. Signal Separation Chart

Table 2. Recommended Test Equipment

Instrument Type	Critical Specifications	Check	Model
Sweep Oscillator	Frequency Range: (directional detector) Power Output: 10 mw Leveled Capability*: $\pm 0.1$ db Residual FM: Less than 50 kc	All	691A/B (786D) H01-692A (787D) H01-693A (788C)
Low-Pass or Bandpass Filter	Frequency Range: (directional detector) Rejection: Not less than 40 db	All	360B (786D) 360C (787D & 786D) 360D (787D & 788C) 8435A (788C) 8436A (788C)
Power Meter and Thermistor Mount	Frequency Range: (directional detector) Power Range: -10 to +10 dbm Accuracy: $\pm 3\%$	Frequency Response Sensitivity	431B (meter) and 478A (mount)
Fixed Attenuator	Frequency Range: (directional detector) Attenuation: 10 db	Frequency Response Sensitivity SWR	Weinschel 210-10
	Frequency Range: (directional detector) Attenuation: (directional detector directivity)	Directivity	Weinschel 210-10 (786D) 210-20 (all) 210-6 (787D)
DC Voltmeter	Range: 20 to 100 mv Input: 10 megohms Accuracy: $\pm 2\%$ of full scale	Sensitivity	410C
SWR Meter	Frequency: 1000 cps $\pm 2\%$ Calibration: Square Law Accuracy: $\pm 0.05$ db (on EXPAND scale) Input: 200K ohms	SWR Directivity	415B or 415D
Directional Detector	Frequency Range: (directional detector) Detected Output: Negative Sensitivity: 4 mv/mw Frequency Response: $\pm 0.3$ db	Directivity	786D (786D) 787D (787D) 788C (788C)
Sliding Load	Frequency Range: (directional detector) Connectors: Standard type N Residual SWR**: 1.05	SWR Directivity	906A
Slotted Line	Frequency Range: (directional detector) Connectors: Standard type N Residual SWR: 1.04	SWR	C05-805C (786D & 787D) C05-806B (788C) 809B (788C)
* Excluding coupler and detector variation (with the 786D the leveling capability would be $\pm 0.3$ db)			
** Residual SWR: 1.10 from 1.0 to 1.5 Gc			

# APPENDIX





## APPENDIX II BACKDATING MANUAL CHANGES

Models 8691A/8692A/8693A/8694A  
RF Unit

MAKE ALL CORRECTIONS IN THIS MANUAL ACCORDING TO ERRATA BELOW, THEN CHECK THE FOLLOWING TABLE FOR YOUR INSTRUMENT SERIAL PREFIX (3 DIGITS) OR SERIAL NUMBER (8 DIGITS) AND MAKE ANY LISTED CHANGE(S) IN THE MANUAL.

► NEW ITEM.

SERIAL PREFIX OR NUMBER	MAKE MANUAL CHANGES	SERIAL PREFIX OR NUMBER	MAKE MANUAL CHANGES
620-	A, B, C, D, E, F, G, H	724-	F, G, H
636-	A, C, D, E, F, G, H	728-	G, H
715-	D, E, F, G, H	822-	H
720-	E, F, G, H		

**CHANGE A:** A2R12 on Freq Shape Assy A2 is adjusted for proper calibration when RF Unit serials prefixed 620 are used with 8690A serials prefixed 615.

If an RF Unit, serials prefixed 620, is used with an 8690A Sweep Oscillator, serials prefixed 636 or above, approximately -1% calibration error will occur. In this case, perform Adjustments 4, HELIX VOLTAGE SHAPING and 5, FREQUENCY ACCURACY, Table 2-3.

A2R12 on Freq Shape Assy A2 is adjusted for proper calibration when RF Unit serials prefixed 636 are used with 8690A serials prefixed 636.

If an RF Unit, serials prefixed 636, is used with an 8690A Sweep Oscillator, serials prefixed 615, approximately +1% calibration error will occur. In this case, perform Adjustments 4, HELIX VOLTAGE SHAPING and 5, FREQUENCY ACCURACY, Table 2-3.

**CHANGE B:** For your instrument serial number (8 digits) listed below, make the following change:  
Change R3 from linear to log type;  
Change stock number from 2100-0060 to 2100-0051.

<u>Model</u>	<u>Serial Number</u>
8691A	636- below 00135
8692A	636- below 00145
8693A	636- below 00134
8694A	636- below 00155

**CHANGE C:** Figure 4-2 and Parts List:  
Add Diode A1CR14, stock number 1901-0033.  
Delete Transistor NPN, A1Q4, stock number 1854-0022.  
Delete Resistor, A1R45, 196k, stock number 0757-0063.

Change schematic to show removal of:

- (1) Resistor, A1R45, 196k connected from collector of A1Q3 to -300V;
- (2) Transistor NPN, A1Q4 as follows:
  - (a) A1Q4 base to collector of A1Q3;
  - (b) A1Q4 collector to +20V;
  - (c) A1Q4 emitter to junction of A1R1 and pin 5 connection to BWO grid;
- (3) Designate stage A1Q4: "EMITTER FOLLOWER."



**CHANGE C:** Substitute the following photograph for Figure 2-6 in Manual.  
(Cont.)

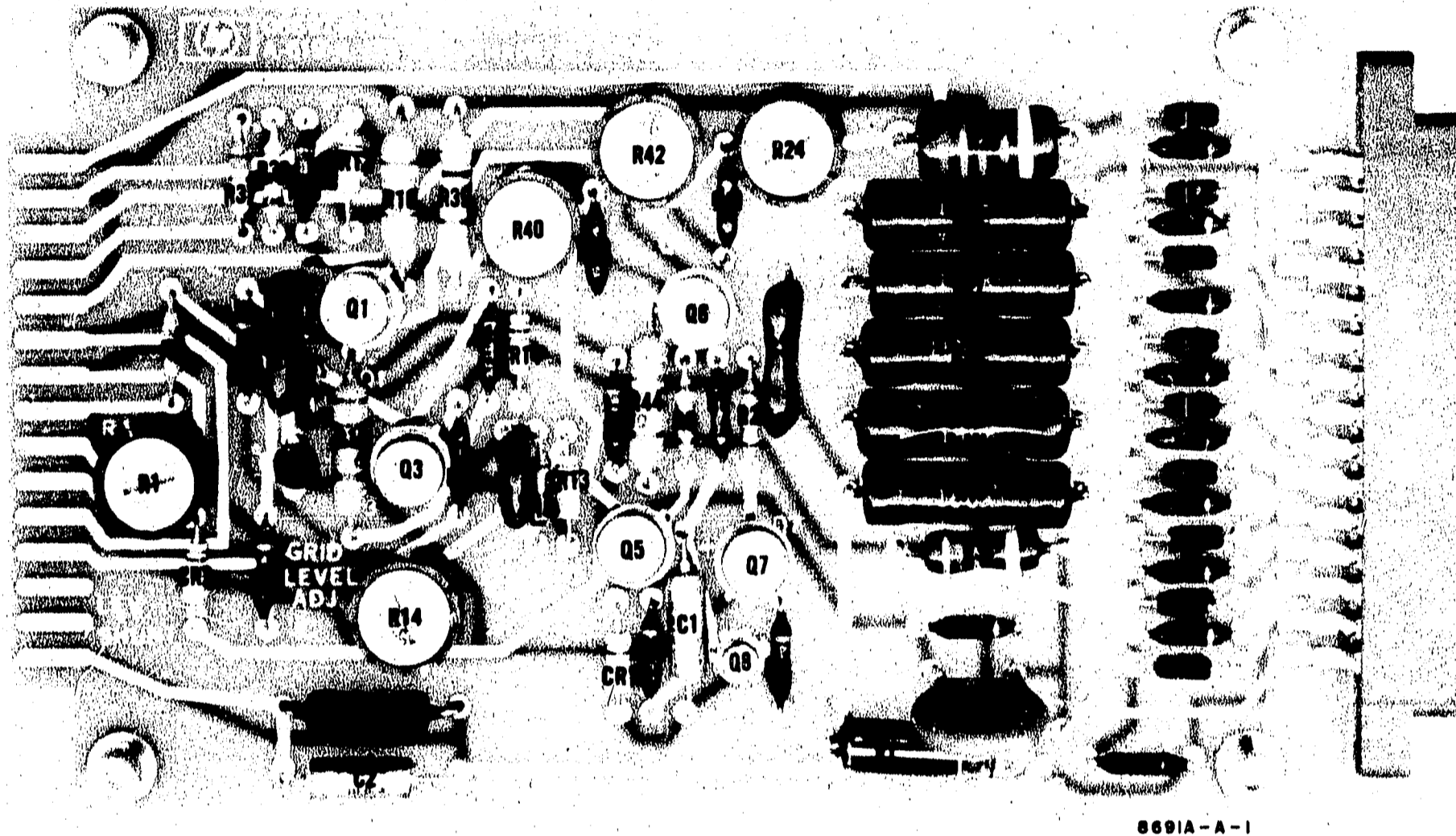

Figure 2-6. Component Identification Assembly A1

**CHANGE D:** Figure 4-2 and Parts List:  
Add Resistor R4 from schematic. Change schematic to show ALC Switch S1B (Option 01 RF Units only) wired so as not to keep R3 EXT ALC GAIN in circuit when S1B is set to INT position (EXT ALC GAIN R3 is used to compensate for ALC Amplifier variations when S1B is set to INT position).

**CHANGE E:** Change the Residual FM specifications in the following instruments for CW operation in START-STOP,  $\Delta F$ , and MARKER SWEEP functions as indicated:

8694A	< 50 kHz peak
H01-8694A	< 50 kHz peak
H02-8694A	< 50 kHz peak

Figure 4-2:  
Add the following jumper connections:  
from P12 pin 16 to P12 pin 10  
from P12 pin 32 to P12 pin 26

Change the chassis ground from P12 pin 8 to P12 pin 6.

To use RF Units serial prefixed 724- and above with 8690A Sweep Oscillators serial numbers 641-00260 and below (including serial prefixed 636- and 615-) it is necessary to disconnect two wires which are connected to pins 26 and 10 of J12 in the 8690A. Removing these wires ensures compatibility and does not affect instrument calibration.

**CHANGE E:  
(Cont.)**

The **WHITE-YELLOW-GREEN** (color 945) wire going to pin 26 of J12 is connected to a push-on connector on the top side of the Interconnection Assembly A7. This wire connects to pin 20 of XA4 through a conductor on Assy A7. Disconnect this wire (color 945) from Assy A7; then cut it off where it enters the cable harness. Tape the cut end to the harness.

The **WHITE-BROWN-YELLOW** (color 914) wire going to pin 10 of J12 can best be disconnected by removing the RF Unit and locating the wire in the cable harness just below J12. Pull out this wire (color 914) far enough so that it can be easily reached and cut out about a one inch section between adjacent turns of the cable harness. Tape the cut ends to the harness.

**CHANGE F:**

Figure 4-2 and Parts List:

Change A1Q2 stock number from 1853-0020 to 1853-0015.

**CHANGE G:**

Change Stock No. of BWO Terminal Board Assy A3 from 08691-6118 to 08691-6105.

**CHANGE H:**

Figure 4-2 and Parts List:

Delete Diode A1CR15, Stock No. 1901-0026.

Figure 2-8 and Parts List:

Add A3M1 and A3R1. Include the following photograph with Figure 2-8, Component Identification, Assembly A3.

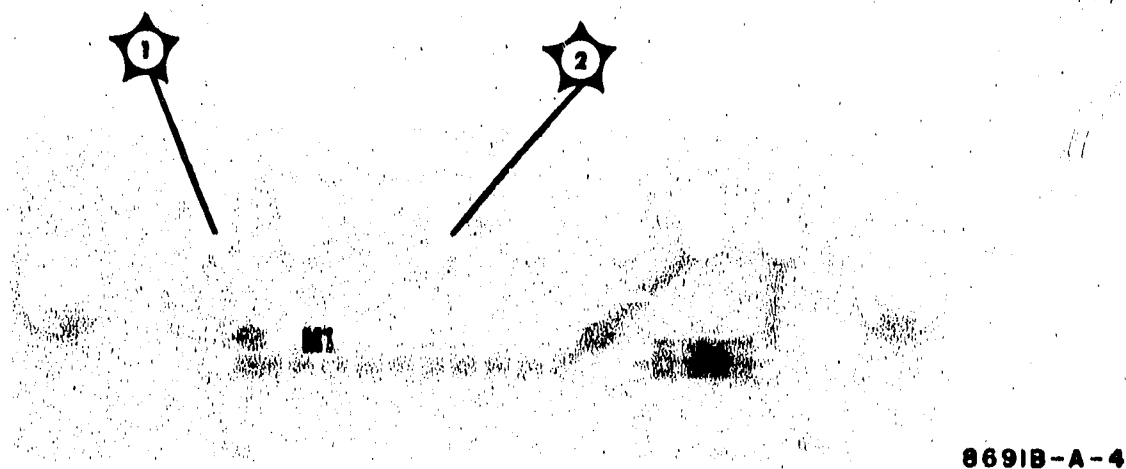

Assembly A3

Figure 2-8. Component Identification, Assembly A3

**Figure 4-2:**

Add Meter M1 and Resistor R1, 2, 4M, in series with one side of meter to A3, ground from BWO Tube V1 and the other side of the resistor to the A3, -6.3V Fil from BWO Tube V1.

**CONDITIONS OF WARRANTY**  
**FOR**  
**BACKWARD WAVE OSCILLATOR TUBES**  
**AND**  
**TRAVELING WAVE TUBES**

Microwave (BWO, TWT) tubes are warranted to be free from manufacturing defects. The operating tube warranty will be 12 months unconditional from date of shipment from Hewlett-Packard. If a tube carrying this warranty fails and must be replaced, only the applicable remaining warranty of the first tube is transferred to the replacement tube, or 90 days, which ever is greater. The Hewlett-Packard Company will process warranty claims for customers on tubes which were supplied by Hewlett-Packard for use in Hewlett-Packard instruments. The serial number of the tube failing and the serial number of the replacement tube must be noted on the warranty claim form.

*"In Warranty"* tubes purchased from Hewlett-Packard must be returned immediately (not to exceed 30 days from date of failure) with a completed Warranty Claim Form, to your local Hewlett-Packard Sales and Service Office. Addresses are listed in the Instrument Manual. Be sure to pack the tube in accordance with the Packing Instructions listed on the Warranty Claim Form; warranty allowance cannot be made on tubes received broken due to improper packaging or showing evidence of tampering.

Instructions for filing a warranty claim are listed on the *"Microwave Tube Warranty Claim"* form which is included with the Operating and Service Manual for your instrument. This form is also included with replacement Microwave tubes supplied by Hewlett-Packard. Additional copies may be obtained from your local Hewlett-Packard Sales and Service Office. (Please ref: HP Stock No. 9320-1865.)

Hewlett-Packard specified replacement tubes can be obtained from your local Hewlett-Packard Sales and Service Office.

# MANUAL CHANGES

# MANUAL CHANGES

## MANUAL IDENTIFICATION

Model Number: 8691A-94A  
Date Printed: November 1968  
Part Number: 08691-90021

This supplement contains important information for correcting manual errors and for adapting the manual to instruments containing improvements made after the printing of the manual.

To use this supplement:

Make all ERRATA corrections

Make all appropriate serial number related changes indicated in the tables below.

Serial Prefix or Number	Make Manual Changes	Serial Prefix or Number	Make Manual Changes
916	1	1144A06006 thru 1144A06955	1 thru 7
967-03806 thru 967-04005	1, 2	1210A06956 thru 1210A07405	1 thru 8
967-04006 thru 967-04155	1, 2, 3	1243	1 thru 9
984	1, 2, 3, 4	1243A07863, 07915, 07938, 07939 & 08001	1 thru 10
0984A05385, 0984A05490 0984A05496, 0984A05564, 0984A05647, 0984A05695 thru 0984A05699 and Serial Prefix 1140A	1 thru 5	1313 thru 1313A09655	1 thru 11
		1335A, 1438A 1445A thru 1445A10455	1 thru 12
		1445A10456 thru 1445A10755	1 thru 13
		1501A, 1526A and 1547A	1 thru 14

### ▶ NEW ITEM

### ERRATA

Entire Manual:

Delete all references to power meter leveling.

Change all H01- and H02- references accordingly:

from H01-8694A to 8694A Option 100

from H01-8694A Option 01 to 8694A Option 100, Option 001

from H02-8694A to 8694A Option 200

from H02-8694A Option 01 to 8694A Option 200, Option 001.

### NOTE

Manual change supplements are revised as often as necessary to keep manuals as current and accurate as possible. Hewlett-Packard recommends that you periodically request the latest edition of this supplement. Free copies are available from all HP offices. When requesting copies quote the manual identification information from your supplement, or the model number and print date from the title page of the manual.

13 NOVEMBER 1975

13 Pages

Printed in U.S.A.



**HEWLETT  
PACKARD**

**ERRATA (Cont'd)**

Pages 1-1 and 1-2, Table 1-1, Specifications:

Add after Option 01 (Internal Leveling) for each model: "Option 004 Rear RF Output."

Change the Frequency Stability specification of the 8691A, 8692A and 8693A RF Units to read as follows:

FREQUENCY STABILITY	8691A	8692A	8693A
With 6 dB Power Level Change	typically less than $\pm 20$ MHz	typically less than $\pm 40$ MHz	typically less than $\pm 80$ MHz

Pages 1-1 and 1-2, Table 1-1, Specifications:

Add the following specification for the 8694A RF Unit:

FREQUENCY STABILITY	8694A
With 6 dB Power Level Change	typically less than $\pm 160$ MHz

Add as a note that Residual FM specifications are degraded by 2 times normal specification when RF units are installed in HP 8707A RF Unit Holder.

Page 1-2, Paragraph 1-8:

Add the following:

**NOTE**

Allow 30 minutes warmup.

Add the following options in the specifications table: The standard 8691A and 8693A specifications apply with the following differences:

	8691A Option 200	8693A Option 200
Frequency Range	1.4 to 2.5 GHz	3.5 to 6.75 GHz
Maximum Leveled Power	At least 100 mW	At least 40 mW
Frequency Stability		
With 6 dB Power Level change from maximum leveled power	typically less than $\pm 30$ MHz	typically less than $\pm 80$ MHz

Page 1-3, Figure 1-2:

Identify 15 pin connector on front panel as Item 7 describe as follows:

P11 connects the BWO operating voltages from the 8690 mainframe to the RF Unit.

Identify 32 pin connector on front panel as Item 8 and describe as follows:

P12 connects the RF Unit operating signals and voltages from the 8690 mainframe to the RF Unit.

Page 2-1, Paragraph 2-3:

Add this note after paragraph 2-3:

**NOTE**

Use a calibrated 8690 mainframe.

Page 2-2:

Change paragraph 2-13 to read:

BWO tube V1 is not covered by the RF Unit warranty. A separate warranty covers the BWO for one full year from the date of shipment from Hewlett-Packard. If the BWO tube fails within this warranty period, use the Warranty Claim form supplied with the BWO tube.

**ERRATA (Cont'd)**

**Page 2-2, Paragraph 2-17:**

Add this Warning after paragraph 2-17:

**WARNING**

A possible **SHOCK HAZARD** exists when Varian BWO tubes are installed if the front panel connector is not grounded to the RF Unit chassis.

**Page 2-5, Table 2-3, Adjustment 5, FREQUENCY ACCURACY:**

Add the following information to list given under step g.

<u>Vdc at Test Point 4 8690 Assembly A4</u>	<u>8691A Opt. 200</u>	<u>Frequency (GHz)</u>	<u>8693A Opt. 200</u>
73.00 ± 0.01	2.50		6.750
66.00 ± 0.01	2.39		6.425
59.00 ± 0.01	2.28		6.100
52.00 ± 0.01	2.17		5.775
45.00 ± 0.01	2.06		5.450
38.00 ± 0.01	1.95		5.125
31.00 ± 0.01	1.84		4.800
24.00 ± 0.01	1.73		4.475
17.00 ± 0.01	1.62		4.150
10.00 ± 0.01	1.51		3.825
3.00 ± 0.01	1.40		3.500
Test Limits (%)	± 0.8		± 0.8

**Page 2-8, Figure 2-5:**

Designate connector that A1 Assy plugs into as XA1.

Designate connector that A2 Assy plugs into as A1XA2.

**Page 2-9, Figure 2-6:**

Change R45 to R16, R16 to R39, and R39 to R45.

**Page 3-1:**

Change paragraph 3-6 to read:

BWO tubes listed in parts list are equivalent substitutes when used with the appropriate Shaping Board Assembly (A2) and Helix Overcurrent Shunt Resistor (A1R17). For more detailed information, refer to Table 3-4.

**ERRATA (Cont'd)**

Page 3-1 (Cont'd):

Add this table following paragraph 3-6.

Table 3-4. BWO Tube, Shaping Board Assembly and Helix Overcurrent Shunt Resistor Combinations

RF Unit Model	BWO Tube (V1)	BWO Manufacturer	Shaping Board Assembly (A2)	Helix Overcurrent <sup>(1)</sup> Shunt Resistor (A1R17)
8691A	1951-0020	Watkins-Johnson	08691-6103	8.25K ohm
8691A, Op.200	1951-0086	Watkins-Johnson	08691-60126	8.25K ohm
8692A	1951-0055	Varian	08692-6102	1.0K ohm
	1951-0064 <sup>(2)</sup>	Watkins-Johnson	08691-6101	8.25K ohm
8693A	1951-0057	Varian	08693-6102	1.0K ohm
	1951-0065 <sup>(3)</sup>	Watkins-Johnson	08693-6101	8.25K ohm
8693A, Op.200	1951-0087	Watkins-Johnson	08693-60118	8.25K ohm
8694A	1951-0058	Varian	08694-6102	1.0K ohm
	1951-0085 <sup>(4)</sup>	Watkins-Johnson	08694-60001	8.25K ohm
8694A Option 100	1951-0058	Varian	08694-6104	1.0K ohm
	1951-0085	Watkins-Johnson	08694-60003	8.25K ohm
8694A Option 200	1951-0058	Varian	08694-6106	1.0K ohm
	1951-0085	Watkins-Johnson	08694-60005	8.25K ohm

<sup>1</sup>The 8.25K ohm helix overcurrent shunt resistor is HP Part No. 0757-0837. The 1.0K ohm helix overcurrent shunt resistor is HP Part No. 0761-0021.

<sup>2</sup>BWO (HP Part No. 1951-0064) is the recommended replacement for BWO (1951-0055) used in all 8692A RF Units (regardless of serial prefix).

<sup>3</sup>BWO (HP Part No. 1951-0065) is the recommended replacement for BWO (1951-0057) used in all 8693A RF Units (regardless of serial prefix).

<sup>4</sup>BWO (HP Part No. 1951-0085) is the recommended replacement for BWO (1951-0058) used in all 8694A RF Units (regardless of option or serial prefix).

Page 3-2, Table 3-1:

Add asterisk (\*) in Note column of A1R11, A1R13 and A1R16.

(\*Factory selected part, typical value given.)

Delete A1CR15.

Page 3-3, Table 3-1:

Add A1XA2 1251-0494 Connector: PC 30 Pin.



**ERRATA (Cont'd)****Page 3-4, Table 3-1:**

- Add A2 08691-60126 ASSY: SHAPING BOARD (08691A Opt. 200)  
REFER TO PARAGRAPH 3-6.**
- Add A2 08693-60118 ASSY: SHAPING BOARD (08693A Opt. 200)  
REFER TO PARAGRAPH 3-6.**

**Page 3-5, Table 3-1:**

- Add CR 1901-0026 Diode: Silicon 0.75A 200 PIV.**
- Add FL1 00693-604 Filter: Low Pass (8693A Opt. 001).**
- Add J1 1250-0083 Connector: RF BNC.**
- Add P1 thru P10 Not Assigned.**
- Add P11 1251-0322 Connector: 15 contact, male.**
- Add P12 1251-0136 Connector: 32 pin, male.**
- Add R5 0757-0273 R:FXD 3.01K 1% 1/8W.**
- Add W1 00691-634 Assy: RF Cable (8692A Opt. 001, 8692A-94A Opt. 004).**
- Add W2 08693-6112 Assy: RF Cable (8693A Opt. 001 WJ 1951-0087 BWO ONLY).**
- Add XA1 1251-0159 Connector: PC 30 pin.**
- Add V1 1951-0086 Tube: Electron, BWO (8691A, Opt. 200) (Refer to Para. 3-6).**
- Add V1 1951-0087 Tube: Electron, BWO (8693A, Opt. 200) (Refer to Para. 3-6).**

**Under Miscellaneous:**

- Add 08691-6125 RF Unit Assy (all Opt. 004 Models).**
- Add 6960-0046 Hole Plug (all Opt. 004 Models).**
- Add HP Part No. 08691-20115 SCALE (8691A Opt. 200).**
- Add HP Part No. 08691-00115 PANEL: FRONT (8691A, Opt. 200).**
- Add HP Part No. 08693-20113 SCALE: (8693A, Opt. 200).**
- Add HP Part No. 08693-00105 PANEL: FRONT (8693A, Opt. 200).**
- ▶ Add HP Part 7120-4162 LABEL INFO.**

**Page 3-6, Table 3-2:**

- Change HP Part No. 08694-0102 (Front Panel) to HP Part No. 08694-0112 (no description change).**
- Change HP Part No. 08694-0104 (Front Panel) to HP Part No. 08694-0114 (no description change).**

**Page 3-7, Table 3-2:**

- Add HP Part No. 00693-604 Filter: Low Pass (8693A Opt. 001); 28480; TQ 1.**
- Add HP Part No. 1250-0083 Connector: RF BNC; 28480; TQ 1.**
- Add HP Part No. 1251-0136 Connector: 32 pin male; 28480; TQ 1.**
- Add HP Part No. 1251-0159 Connector: PC 30 pin, male; 28480; TQ 1.**
- Add HP Part No. 1251-0494 Connector: PC 30 pin, 28480, TQ 1.**
- Add HP Part No. 1251-1322 Connector: 15 contact, male; 28480, TQ 1.**

**Page 3-8, Table 3-2:**

- Add HP Part No. 6960-0046 Hole Plug (Option 004 Models only); 28480; TQ 1.**
- Add HP Part No. 08691-6125 RF Unit Assy (Option 004 Models only); 28480; TQ 1.**
- Add HP Part No. 08693-6112 Assy: RF Cable (8692A, 8693A, and 8694A Option 001 Models); 28480; TQ 1.**
- Change HP Part No. 08694-0102 to HP Part No. 08694-0112.**
- Change HP Part No. 08694-0104 to HP Part No. 08694-0114.**

**CHANGE 2**

No change. Affects only the 8694B RF Units.

**CHANGE 3**

Page 3-5, Table 3-1:

Delete DS1 listing of HP Part No. 1450-0152.

Add as part of DS1, 1450-0371 LENS:LAMPHOLDER, Amber.

**CHANGE 4**

Serial prefix change only.

**CHANGE 5**

Note that this change affects the Model 8693A Option 001 only.

Page 1-2, Table 1-1:

Under Option 001 Internal Leveling add:

Maximum Leveled Power: At least 25 mW.

Page 3-5, Table 3-1:

Last A4 Listing:

Change HP Part No. to 08693-60119. (Recommended replacement for 08693-6110).

Page 4-5/4-6, Figure 4-3:

On the Option 001 8693A (fourth from top):

Delete CP1 Adapter HP Part No. 1250-0777.

Change A4 Directional Detector HP Part No. to 08693-60119. (Recommended replacement for 08693-6110).

**CHANGE 6**

Page 3-5, Table 3-1, under MISCELLANEOUS:

Add the following note to define the 8691A-94A color scheme.

**NOTE**

This change implements a different color scheme for the standard instrument.  
Colors prior to this change are now available as options. Refer to listing below.

8691A-94A STANDARD — Indicates color scheme for the 8691A-94A Models beginning with this change. (Includes MINT GRAY front panel).

8691A-94A Option A85 — Indicates combination color scheme. (Includes LIGHT GRAY front panel.)

8691A-94A Option X95 — Indicates color scheme for the 8691A-94A Models prior to this change. (Includes LIGHT GRAY front panel).

**CHANGE 6 (Cont'd)****Page 3-5, Table 3-1 (Cont'd)**

Add the following 8691A-94A parts or description changes:

- 08691-0100 FRONT PANEL (LIGHT GRAY) (8691A, AND 8691A OPTIONS 001 AND 004).
- # 08691-00118 FRONT PANEL (MINT GRAY) (STANDARD) (8691A, AND 8691A OPTIONS 001 AND 004).
- 08691-2111 FRONT HOUSING (LIGHT GRAY) (8691A-94A).
- # 08691-20116 FRONT HOUSING (MINT GRAY) (STANDARD) (8691A-94A).
- # Denotes standard color for 8691A-94A parts beginning with this change.

**Page 3-6, Table 3-1, under MISCELLANEOUS :**

Add the following 8691A-94A parts or description changes:

- 08691-2112 REAR PANEL (LIGHT GRAY) (8691A-94A).
- # 08691-20117 REAR PANEL (MINT GRAY) (STANDARD) (8691A-94A).
- 08691-2114 REAR PANEL (LIGHT GRAY) (8691A-94A OPT 004).
- # 08691-20118 REAR PANEL (MINT GRAY) (STANDARD) (8691A-94A OPT 004).
- 08691-4003 LATCH HANDLE (LIGHT GRAY) (8691A-94A).
- # 08691-40005 LATCH HANDLE (MINT GRAY) (STANDARD) (8691A-94A).
- 08691-00115 FRONT PANEL (LIGHT GRAY) (8691A OPT 200).
- # 08691-00120 FRONT PANEL (MINT GRAY) (STANDARD) (8691A OPT 200).
- 08692-0100 FRONT PANEL (LIGHT GRAY) (8692A).
- # 08692-00007 FRONT PANEL (MINT GRAY) (STANDARD) (8692A).
- 08693-0100 FRONT PANEL (LIGHT GRAY) (8693A, AND 8693A OPTIONS 001 AND 004).
- # 08693-00111 FRONT PANEL (MINT GRAY) (STANDARD) (8693A, AND 8693A OPTIONS 001 AND 004).
- 08693-00109 FRONT PANEL (LIGHT GRAY) (8693A OPT 200).
- # 08693-00114 FRONT PANEL (MINT GRAY) (STANDARD) (8693A OPT 200).
- 08694-0100 FRONT PANEL (LIGHT GRAY) (8694A, AND 8694A OPTIONS 001 AND 004).
- # 08694-00124 FRONT PANEL (MINT GRAY) (STANDARD) (8694A, AND 8694A OPTIONS 001 AND 004).
- 08694-0112 FRONT PANEL (LIGHT GRAY) (8694A OPT 100).
- # 08694-00126 FRONT PANEL (MINT GRAY) (STANDARD) (8694A OPT 100).
- 08694-0114 FRONT PANEL (LIGHT GRAY) (8694A OPT 200).
- # 08694-00128 FRONT PANEL (MINT GRAY) (STANDARD) (8694A OPT 200).
- # Denotes standard color for 8691A-94A parts beginning with this change.

**CHANGE 7****Page 3-2, Table 3-1:**

Change transistors A1Q1, A1Q4, and A1Q6 to HP Part No. 1854-0079 TRANSISTOR: SILICON NPN. (Recommended replacement for 1854-0232.)

**Page 4-3, Figure 4-2:**

Change transistors A1Q1, A1Q4, and A1Q6 to HP Part No. 1854-0079.

**CHANGE 8**

Page 3-4, Table 3-1:

Add A2 HP Part No. 08694-60001, Assy Freq. Shape (8694A Option 001) used with Watkins-Johnson BWO HP Part No. 1951-0085.

Page 3-5, Table 3-1:

Add V1 HP Part No. 1951-0085, Watkins-Johnson BWO used in 8694A Option 001.

**CHANGE 9**

Page 3-1, Table 3-4:

Change 8694A second line to read: 1951-0085<sup>(4)</sup>, Watkins-Johnson, 08694-60001, 8.25K ohm.

Change 8694A Option 100 second line to read: 1951-0085, Watkins-Johnson, 08694-60002, 8.25K ohm.

Change 8694A Option 200 second line to read: 1951-0085, Watkins-Johnson, 08694-60003, 8.25K ohm.

Change footnote 4 to read: BWO (HP Part No. 1951-0085) is the recommended replacement for BWO (1951-0058) used in all 8694A RF Units (regardless of option or serial prefix).

Page 3-4, Table 3-1:

Add A2 HP Part No. 08694-60001 ASSY:FREQ SHAPE (8694A) USED W/1951-0085 WJ BWO.

Change A2 HP Part No. 08694-6101 to read: ASSY: FREQ SHAPE (8694A) USED W/1951-0066 as ALT for 1951-0085 BWO.

Add A2 HP Part No. 08694-60002 ASSY:FREQ SHAPE (8694A Option 100 and 8694A Option 100/004) USED W/1951-0085 WJ BWO.

Change A2 HP Part No. 08694-6103 to read: ASSY: FREQ SHAPE (8694A Option 100 and 8694A Option 100/004) USED W/1951-0066 as ALT for 1951-0085 BWO.

Add A2 HP Part No. 08694-60003 ASSY:FREQ SHAPE (8694A Option 200 and 8694A Option 200/004) USED W/1951-0085 WJ BWO.

Change A2 HP Part No. 08694-6105 to read: ASSY: FREQ SHAPE (8694A Option 200 and 8694A Option 200/004) USED W/1951-0066 as ALT for 1951-0085 BWO.

Page 3-5, Table 3-1:

Add V1 HP Part No. 1951-0085 ELECTRON TUBE: BWO (8694A and all options).

Change V1 HP Part No. 1951-0066 to read: ELECTRON TUBE: BWO (ALT FOR 1951-0085).

**CHANGE 10**

(This change applies only to the Model 8693A Option 001).

Page 3-1, Table 3-4, (Page 4 of Manual Changes: ERRATA):

Change Footnote 3 to read: BWO (HP Part No. 1951-0065) is the recommended replacement for BWO (1951-0057) used in all 8693A RF Units (regardless of serial prefix) except for 8693A Option 001.

Page 3-4, Table 3-1:

Change description of A2 HP Part No. 08693-6101 to read:

ASSY: FREQ SHAPE (8693A) USED W/1951-0065 BWO (NOT TO BE USED W/OPT 001).

Change description of A2 HP Part No. 08693-6102 to read:

ASSY: FREQ SHAPE (8693A Option 001) USED W/1951-0057 BWO.

Page 3-5, Table 3-1:

Change V1 description of HP Part No. 1951-0057 to read:

ELECTRON TUBE: BWO 8693A and Option 001.

Add W4 HP Part No. 08692-6115 CABLE ASSY: 8692A-93A Option 001 used with Varian BWO only.

Add W5 HP Part No. 08691-6115 CABLE ASSY: Option 001 HARNESS.

**CHANGE 11**

Page 3-4, Table 3-1:

Delete A2 HP Part No. 08694-6101 ASSY: FREQ SHAPE (8694A).

Delete A2 HP Part No. 08694-6103 ASSY: FREQ SHAPE (8694A Option 100 and 8694A Option 100/004).

Delete A2 HP Part No. 08694-6105 ASSY: FREQ SHAPE (8694A Option 200 and 8694A Option 200/004).

Page 3-5, Table 3-1:

Delete V1, HP Part No. 1951-0066 ELECTRON TUBE: BWO (ALT for 1951-0085).

Add W3 HP Part No. 08692-6114 CABLE ASSY: 8692A-94A STD used with Varian BWO only.

Add W4 HP Part No. 08692-6115 CABLE ASSY: 8692A-94A Option 004 used with Varian BWO only.

**CHANGE 12**

Page 3-2, Table 3-1:

Change A1Q5 to HP Part No. 1854-0003.

**CHANGE 13**

Page 3-5, Table 3-1:

Change FRONT HOUSING (MINT GRAY) (STANDARD) (8691A-94A) to HP Part No. 08695-20010

FRONT HOUSING (MINT GRAY) (STANDARD COLOR) (8691A-94A STANDARD and ALL OPTIONS).

Page 3-6, Table 3-1:

Change REAR PANEL (MINT GRAY) (STANDARD) (8691A-94A) to HP Part No. 08691-20118, REAR  
PANEL (MINT GRAY) (STANDARD COLOR) (8691A-94A).

**►CHANGE 14**

Serial Prefix change only. Does not affect performance of instrument.

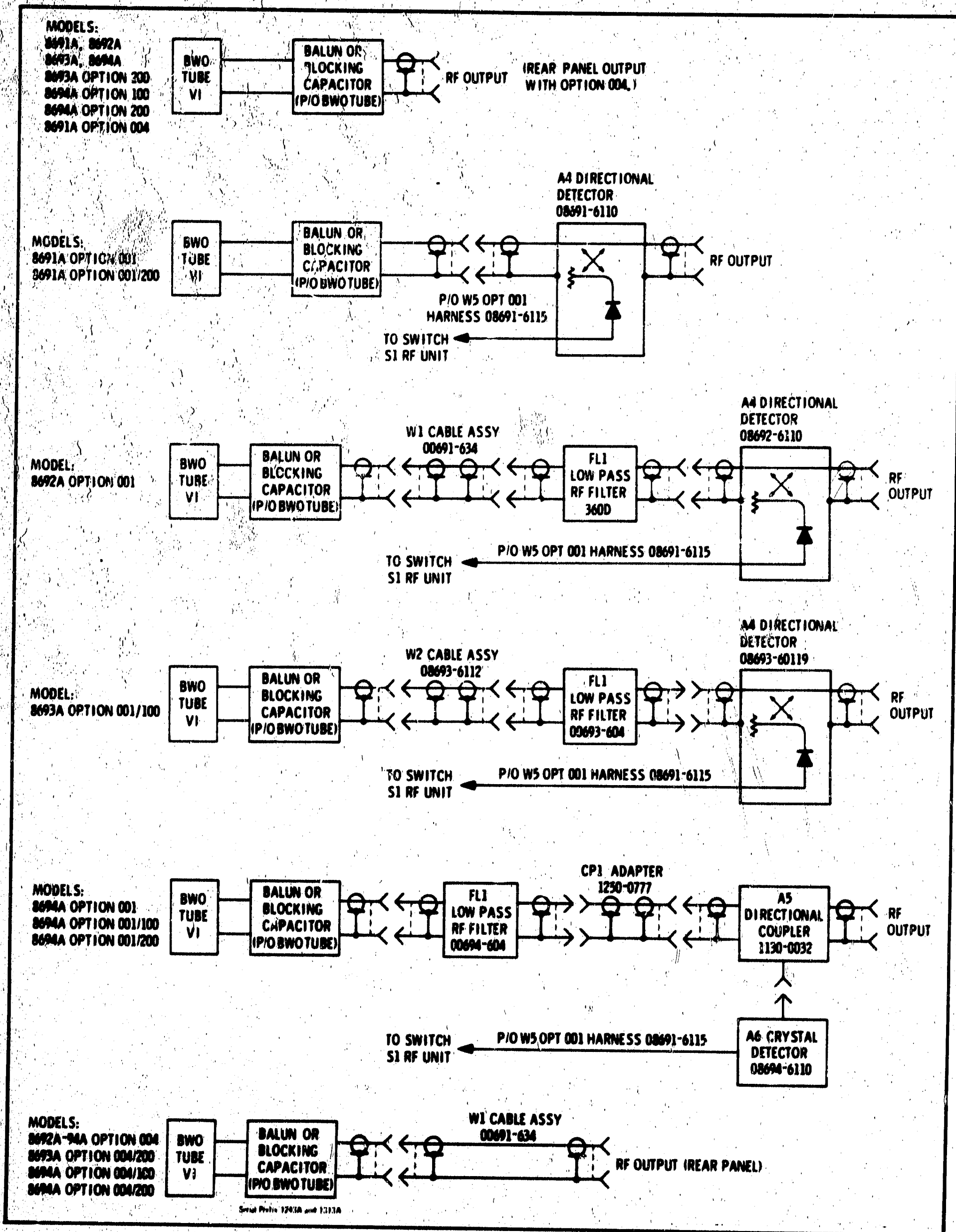

Figure 4-3. (Page 4-5)

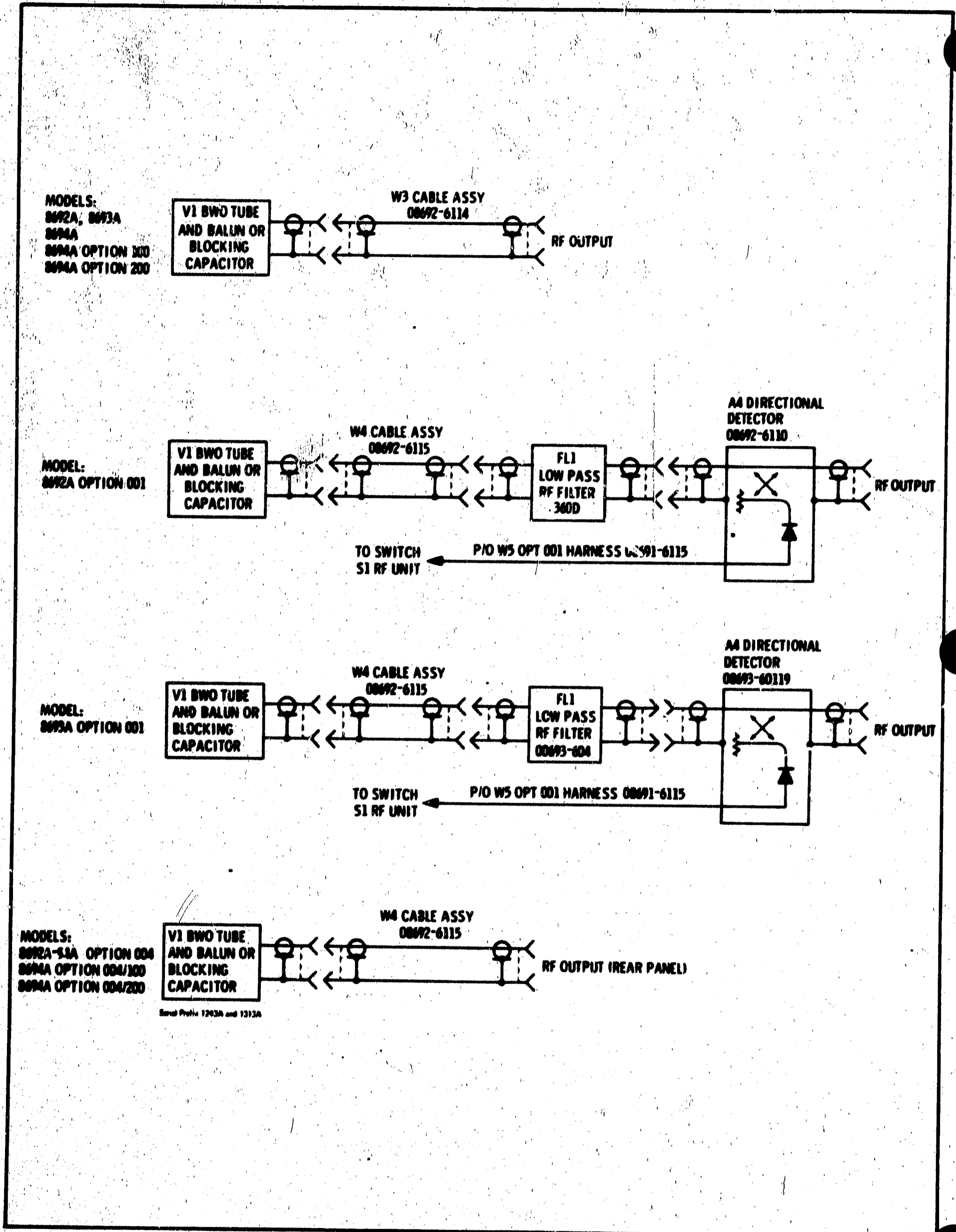

Figure 4-4. (Page 4-7)



**CONDITIONS OF WARRANTY  
FOR  
BACKWARD WAVE OSCILLATOR TUBES  
AND  
TRAVELING WAVE TUBES**

Microwave (BWO, TWT) tubes are warranted to be free from manufacturing defects. The operating tube warranty will be 12 months unconditional from date of shipment from Hewlett-Packard. If a tube carrying this warranty fails and must be replaced, only the applicable remaining warranty of the first tube is transferred to the replacement tube, or 90 days, whichever ever is greater. The Hewlett-Packard Company will process warranty claims for customers on tubes which were supplied by Hewlett-Packard for use in Hewlett-Packard instruments. The serial number of the tube failing and the serial number of the replacement tube must be noted on the warranty claim form.

"In Warranty" tubes purchased from Hewlett-Packard must be returned immediately (not to exceed 30 days from date of failure) with a completed Warranty Claim Form, to your local Hewlett-Packard Sales and Service Office. Addresses are listed in the Instrument Manual. Be sure to pack the tube in accordance with the Packing Instructions listed on the Warranty Claim Form; warranty allowance cannot be made on tubes received broken due to improper packaging or showing evidence of tampering.

Instructions for filing a warranty claim are listed on the "Microwave Tube Warranty Claim" form which is included with the Operating and Service Manual for your instrument. This form is also included with replacement Microwave tubes supplied by Hewlett-Packard. Additional copies may be obtained from your local Hewlett-Packard Sales and Service Office. (Please ref: HP Stock No. 9320-1865.)

Hewlett-Packard specified replacement tubes can be obtained from your local Hewlett-Packard Sales and Service Office.